

**RINDI: AN ETHNOGRAPHIC STUDY
OF A TRADITIONAL DOMAIN IN EASTERN SUMBA**

VERHANDELINGEN
VAN HET KONINKLIJK INSTITUUT
VOOR TAAL-, LAND- EN VOLKENKUNDE

93

GREGORY L. FORTH

RINDI

AN ETHNOGRAPHIC STUDY
OF A TRADITIONAL DOMAIN IN EASTERN SUMBA



THE HAGUE - MARTINUS NIJHOFF 1981

© Copyright 1981 by
*Koninklijk Instituut voor Taal-, Land-, en Volkenkunde,
Leiden, the Netherlands.*

*All rights reserved, including the rights to translate
or to reproduce this book or parts thereof in any form.*

Printed in the Netherlands.

ISBN 90.247.6169.7

PREFACE

This study is based on 22 months of fieldwork carried out in Rindi, a traditional community in the eastern part of the Indonesian island of Sumba, and in a slightly different form was submitted as a thesis for the degree of Doctor of Philosophy at the University of Oxford. The work was funded from a Social Science Research Council project grant awarded to Professor Rodney Needham, with my wife and I named as research assistants, and was conducted under the auspices of the Lembaga Ilmu Pengetahuan Indonesia. I should therefore like to express my gratitude to both these bodies.

Since my wife, Christine Forth (who is also a social anthropologist), worked with me in Rindi, many of the data on which this enquiry is based, in particular those obtained from collecting and checking genealogies, are the product of her efforts. I also owe a great debt to my wife for insights provided both in the field and subsequently. But while the present work has thus benefited from her general assistance and support, any shortcomings in the analysis or conclusions are my responsibility alone. Some minor alterations to the original manuscript derive from suggestions made by Dr. Nick Allen and Mme. Brigitte Clamagirand, who examined my doctoral thesis. However, while I am grateful to them for their comments, I have not followed their advice in every case, and the decision as to what changes were to be made was taken entirely by myself.

In the field, there were many persons, notably the noble and other residents of Parai Yawangu, the chief village of Rindi, and the inhabitants of Parai Kahembi, Rànga, and other nearby villages, who by regularly inviting us to observe ritual and other customary undertakings and by suffering our continual impromptu visits greatly assisted our work. But it would be neither practical nor entirely fitting to list all of them here by name. One person who must be mentioned, however, is Kalambaru Mahangu, a priest and major ritual speaker in his seventies, who, we were saddened to hear, died in the year following our departure. What knowledge I have of Rindi ritual language derives largely

from instruction provided by him; and since he also proved a valuable informant in general and a close friend, whatever success can be claimed for this study is in no small measure the result of his unflagging efforts on our behalf. In transcribing tape-recorded performances in ritual language I was assisted at different times by several young men, notably Nggaba Ngunjurau and Lu Takanjanji, to whom I am also grateful. In addition, I should like to acknowledge the help of Woha Waluwanja, his wife Hàra Tola, and their children, who ran our household and greatly assisted us in many other ways.

Before going to the field I carried out an analysis of published and unpublished literary materials concerning social organization and culture on Sumba as a whole (see Forth 1974). This was conducted in Oxford and at various libraries and archives in the Netherlands and submitted for the Bachelor of Letters degree at the University of Oxford. Though I do not propose to assess here the merits and defects of even the longer writings on Sumba*, I should like especially to mention the work of Dr. L. Onvlee, my external examiner for the Bachelor of Letters degree, who as a translator for the Netherlands Bible Society lived on Sumba for some thirty years. Onvlee's writings, many of which have recently been collected in a single volume (1973), display a profound and thorough knowledge of Sumbanese languages and culture; and these, as well as the several discussions I had with him before going to Sumba, provided a valuable stimulus to my own, by comparison limited, investigations. Onvlee's Sumbanese colleague, Umbu Hina Kapita, a Mangili nobleman and former school teacher, has also written a good deal on the culture and history of Sumba, and the two volumes of his work (1976a, 1976b) that were published just before I left Indonesia have since been most useful in supplementing my own findings. In addition, Kapita has compiled a Kambera (eastern Sumbanese)-Indonesian dictionary (1974), as yet unpublished, which he kindly allowed me to consult and which served me as a valuable reference work in the field. I am also grateful to Kapita for advice given to us while we were in Waingapu, the main port town on Sumba, where he now mostly resides.

While it is not practicable to mention all the anthropological works that have influenced the general form and approach of this enquiry, I

* The most complete list of published and unpublished work dealing with Sumba, most of which is by missionaries and administrators, is that found in J. J. and I. Fox, 'A working Bibliography on the Islands of Roti, Savu, and Sumba in Eastern Indonesia' (unpublished, no date).

should like to acknowledge the example set by R. H. Barnes's detailed and penetrating study of Kédang (1974). As Dr. Barnes's monograph concerns a society in many ways similar to the one I describe here it has also proven a most useful source of comparative evidence, and the order in which I have chosen to present various topics has been influenced, beneficially I believe, by that followed in his book. From Michaelmas term 1978 until Trinity term 1980, when I submitted my thesis, Dr. Barnes moreover served as my academic supervisor at Oxford. Thus the present enquiry has further benefited from his personal guidance as well.

Finally, I wish to express my gratitude to Professor Rodney Needham for supervising my earlier studies both at the University of Oxford and in the field, and for his continual encouragement, advice, and assistance to the present date.

CONTENTS

Preface	V
List of Maps	XIV
List of Plates	XIV
List of Figures	XV
List of Tables	XVI
<i>Introduction</i>	1
1. Physical Setting	3
2. Some Themes in the History of Eastern Sumba	7
3. A Brief History of Rindi	10
4. Demography and Modern Administration	13
5. Subsistence and Economy	14
6. Language	17
7. Fieldwork	20
<i>I. The House</i>	23
1. Types of Houses	23
2. Form	25
3. Structure	25
4. Principles of Order	31
5. Numbers	34
6. Categories	37
<i>II. The Village and the Domain</i>	45
1. The Domain	45
2. <i>Paraingu</i> and <i>Kotaku</i>	46
3. Spatial Order	50
4. A Note on Orientation	55

<i>III. Space and Cosmos</i>	58
1. <i>Papa</i>	59
2. <i>Dia/Luru</i> and <i>Dita/Wawa</i>	60
3. <i>Lua</i>	64
4. Summary Remarks on Orientation in Eastern Sumba	65
5. Cosmology	66
<i>IV. Hamangu and Ndewa</i>	73
1. <i>Hamangu</i>	73
2. <i>Ndewa</i>	76
<i>V. Divinity and the Ancestors</i>	83
1. God	83
2. <i>Marapu</i>	87
3. <i>Tunggu Marapu</i>	94
4. Special Attributes of Individual <i>Marapu</i>	98
<i>VI. The Powers of the Earth</i>	104
1. Spirits of the Outside	105
2. Witches	113
3. Altars, Boundaries, and Media	118
4. Summary Remarks on Rindi Religion	128
<i>VII. Birth</i>	133
1. Conception and Pregnancy	133
2. <i>Pamandungu Pelungu</i>	138
3. Delivery	141
4. Naming and Other Rites	144
5. Confinement	148
6. <i>Hàngguru</i>	152
7. Summary of Major Themes	153
<i>VIII. Age and the Life Cycle</i>	155
1. Age Classes	155
2. The Hair	157
3. <i>Puru la Wai</i> : Initiation	159
4. Other Usages Associated with Maturity	163
5. <i>Kikiru Matua</i>	166
6. Age and Authority	168

<i>IX. Death</i>	171
1. Preparation of the Corpse	171
2. Burial	179
3. Funerary Prestations	183
4. <i>Bànjalu Wai Mata</i> : The End of Mourning	185
5. The Location of the Soul	187
6. <i>Pahili Mbola</i>	189
7. Hot Death	191
8. Distinctions According to Age	194
9. Distinctions According to Rank	195
10. An Interpretation of Mortuary Symbolism	199
11. The Symbolism of Numbers	210
<i>X. Class Stratification</i>	214
1. Slaves	215
2. The Nobility	221
3. Commoners	227
4. Class, Descent, and Alliance	230
<i>XI. The Division of Authority</i>	236
1. <i>Ratu</i> and <i>Maràmba</i>	237
2. <i>Mangu Tanangu</i>	249
3. Dual Leadership in Rindi	254
4. <i>Tulaku Paraingu</i> and <i>Mbapa Tunu Manahu</i>	257
5. Authority within the Village and Clan	260
6. Summary Remarks on Bases of Authority	263
<i>XII. Descent Groups</i>	265
1. The Clan	265
2. Segmentation	269
3. Corporations	274
4. Corporate Aspects of the Village	280
<i>XIII. The Alliance Relation</i>	282
1. Categories	282
2. Wife-givers and Wife-takers	284
3. Alliance and Descent	289
4. Services	291
5. Patterns of Behaviour	295

<i>XIV. Relationship Terminology</i>	302
1. General Remarks	307
2. Analysis: Reference Terms (Male Ego)	311
3. Principles of Classification	315
4. Analysis: Reference Terms (Female Ego)	317
5. Terms of Address	319
6. Mourning Usages	324
7. Comparative Remarks on Reference and Address	325
 <i>XV. Marriage</i>	 328
1. Rules	328
2. The Arrangement of Marriages	333
3. Polygyny	336
4. Widow-Inheritance	338
5. Divorce and Separation	340
6. Incorporation	342
7. Marriage among Slaves	345
 <i>XVI. Adultery and Incest</i>	 348
1. <i>Njuraku</i>	348
2. Adultery	349
3. Incest	351
4. Summary Remarks on the Significance of Sexual Transgression	356
 <i>XVII. Prestations</i>	 359
1. Components	359
2. Valuation	362
3. Division of the Bridewealth	364
4. The Significance of Marriage Prestations	368
 <i>XVIII. Forms of Contracting Marriage</i>	 374
1. General Remarks	374
2. The 'High Form' of Marriage: <i>Àpa Mamoha</i>	376
3. <i>Tama la Kurungu</i>	381
4. Simpler Procedures	384
5. Elopement and Marriage by Abduction	388
6. Comparative Remarks on Marriage Procedures	390

Contents	XIII
<i>XIX. Prescription and Practice</i>	395
1. Evidence	396
2. Interpretation	400
3. Cycles	409
4. Alliance among Slaves	413
<i>Concluding Remarks</i>	415
<i>Appendices</i>	
I. Genealogy of the Rulers of Rindi	422
II. Descent Groups in Rindi: Current Size	423
III. Current Number of <i>Ata</i> (Slaves) attached to Rindi Clans and Lineages	426
Notes	427
Glossary	491
Works Cited	499
Index of Authors	507
Subject Index	509
Plates	

LIST OF MAPS

	page
1. Sumba and Neighbouring Islands	2
2. Sumba	4
3. Rindi (core area)	6

LIST OF PLATES

- 1a. Peaked houses and graves (Kanoru)
- 1b. A yard altar (*katoda kawindu*) (Parai Kahembi)
- 2a. A baby with rudimentary forelock
- 2b. The unmarried girls' hairstyle
- 3a. The hairstyle of mature men
- 3b. The hairstyle of mature women
- 4a. A grave with 'limbs' and one without (Parai Yawangu)
- 4b. Hauling a small gravestone (Parai Yawangu)
- 5a. Carrying a corpse from the house to the grave (Parai Yawangu)
- 5b. Women placing an offering on a grave (*bànjalu pahàpa*) (Parai Yawangu)
- 6a. *Paratu* during the renovation of the 'Ndewa House' of Ana Mburungu (Parai Yawangu)
- 6b. The senior man of the clan Maleri in formal dress (Kayuri)

LIST OF FIGURES

	page
1. Floor Plan of an Ancestral House (<i>Uma Marapu</i>)	26
2a. Beams and Cross Pieces	33
2b. Disposition of <i>Pingi</i> and <i>Kapuka</i> in Series of Beams and Other Horizontal Components	33
3. Sketch of the Rindi Chief Village, Parai Yawangu	51
4. Disposition of the Corpse before Burial	174
5. Simplified Representation of One Version of the Journey of the Soul	204
6. Genealogical Relations among the <i>Ratu</i> and <i>Maràmbu</i> of Umalulu	239
7. Segmentation of the Noble Clan Ana Mburungu	272
8. Physical Passage of the Bride's Substitute	381
9. An Instance of Direct Exchange	406
10. Partial Genealogy of Mahora-Uma Pada Njara showing Marriages with Dai Ndipi and Other Wife-givers	408

LIST OF TABLES

	page
1. Relationship Terminology (Terms of Reference, Male Ego)	302
2. Relationship Terminology (Terms of Reference, Female Ego)	304
3. Relationship Terminology (Terms of Address, Male Ego)	305
4. Relationship Terminology (Terms of Address, Female Ego)	306
5. Categories of Descent and Alliance (Reference Terms, Male Ego)	313
6. Categories of Descent and Alliance (Reference Terms, Female Ego)	313
7. Categories of Descent and Alliance (Address Terms, Male Ego)	320
8. Categories of Descent and Alliance (Address Terms, Female Ego)	320
9. Women's Mourning Terms	325
10. Relationship of Co-wives in Polygynous Unions	337
11. Marriages of Slaves	346
12. Correct and Incorrect Marriages	396
13. Marriages with the Mother's Brother's Clan and with the Genealogical MBD	399
14. Marriages of Smaller and Largest Descent Groups	402
15. Marriages of Higher and Lower Rankin Groups	402
16. Examples of Three-Group Cycles	412

INTRODUCTION

While the main purpose of this enquiry is ethnographic, I have endeavoured to describe Rindi culture, or what they refer to as their *huri*,¹ within an analytic framework that illustrates connexions between, and common principles among, often apparently disparate realms of thought and action. The study thus attempts to isolate a limited number of categories, forms, and relations of the most general kind which are expressed either directly in the Rindi language or implicitly in conceptual unities and distinctions that can be abstracted from institutions and representations. I am therefore somewhat more interested in common ideas and social action as it expresses these ideas than in more directly observable patterns or tendencies of behaviour, which are often best presented in statistical form or by citing numerous accounts of particular cases. I have, however, included some data of this sort, in particular where they have proved relevant to an understanding of relations between rules and manifest social organization.

As I have found no natural or necessary place to begin the exposition, the arrangement of topics is somewhat arbitrary; and the material could probably have been presented in a number of other ways. With this in mind, therefore, I have provided cross-references to other chapters and sections throughout. Since I was first attracted to eastern Sumba² by reports of asymmetric prescriptive alliance there, a large part of what follows is taken up with the analysis of the component institutions and symbolic accompaniments of this form of social order; but I have found it more useful to discuss these topics after considering certain more general categories and principles, in order to place the alliance system within a wider context. The earlier chapters, therefore, deal with such matters as the form and arrangement of buildings and settlements, classes of spiritual entities, the life cycle, bases of authority, and various forms of social grouping. Due to limitations of space I have been unable to present a number of data which could have been accommodated within the framework I propose. I have also had largely to exclude such topics as material culture and economy, though I found

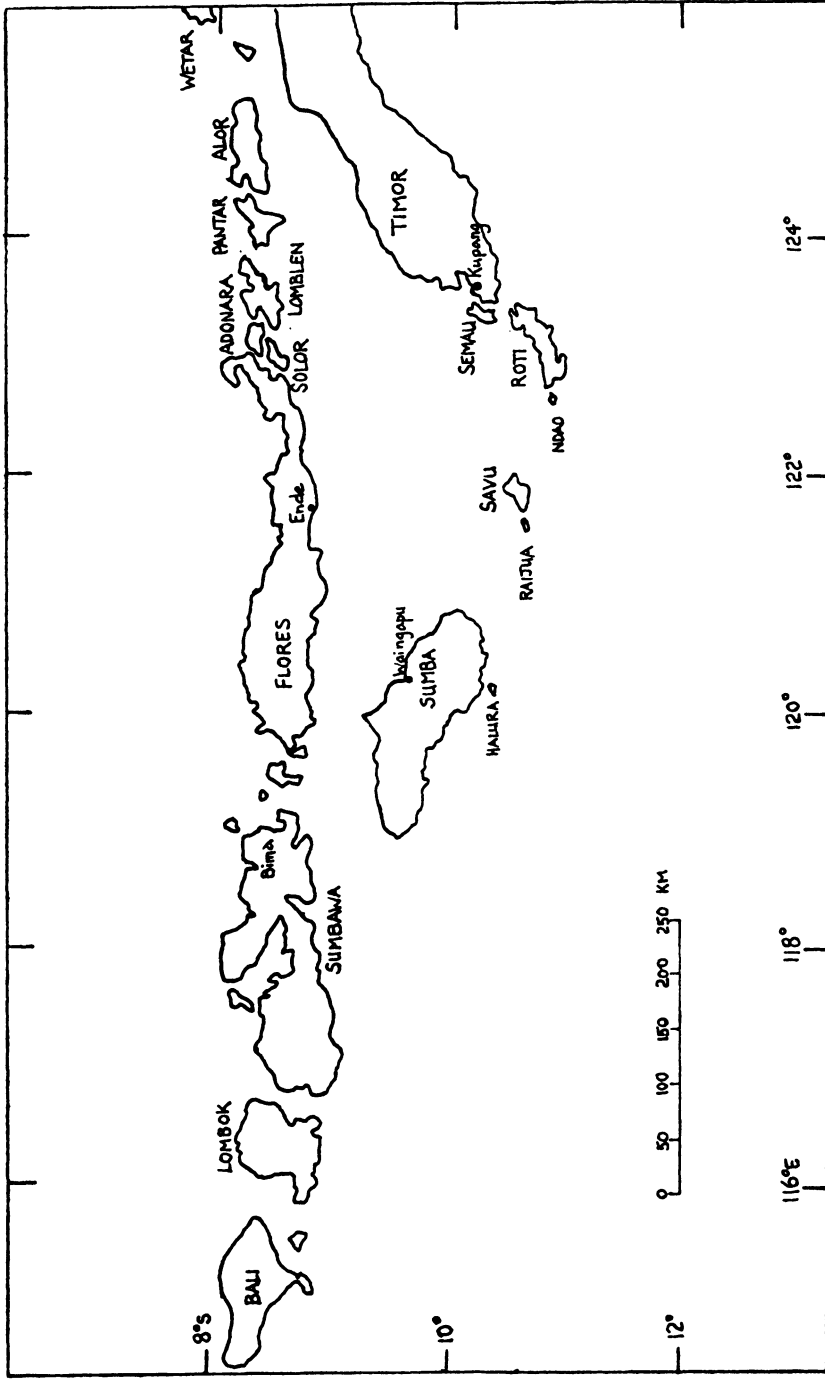

MAP 1. Sumba and Neighbouring Islands

these to have little direct relevance to my primary focus. This is an investigation of traditional culture, and I have paid little attention here to modern elements in Rindi life. To do so adequately would require an entirely different study.

Similarities of language, mythical tradition, and custom found throughout Sumba, and especially within the eastern region, strongly suggest a single derivation for all Sumbanese. It is also consistent with this that the Rindi (in my presence, at any rate) usually referred to themselves as Tau Humba, 'Sumbanese', and to their language and culture as Hilu Humba and Huri Humba respectively. To speak only of eastern Sumba, moreover, the territorial groupings which I call domains, though they traditionally formed fairly discrete political units, include members of clans whose segments extend all over the eastern region; and many domains have long maintained regular contact, including a good deal of inter-marriage, with one another. Given also that the island has an area of 12,297 km. sq., of which eastern Sumba constitutes about three-quarters, the ethnographer is thus immediately faced with the problem of how to delimit the geographical scope of his enquiry. A major shortcoming of nearly all that has so far been written about Sumba is that the authors mostly speak of the island as a whole or only of eastern and western Sumba. As the eastern region in particular does indeed display quite a remarkable homogeneity of culture and language, this is somewhat understandable. But there are nevertheless significant local differences of dialect and custom, some of which the people themselves recognize; and in the interests of ethnographic precision these must of course be controlled. Indeed, it was partly for this reason that I decided to restrict my attention in the field almost entirely to a single domain. Throughout the text, therefore, I have mostly referred to Rindi alone, mentioning eastern Sumba only in places where it is necessary or useful to specify a wider context. One drawback of this approach is that it might suggest that Rindi forms a discrete cultural, historical, and linguistic entity, which it clearly does not. Nevertheless, I think that any disadvantages this entails are far outweighed by the advantage of avoiding unwarranted generalization.

1. Physical Setting

Sumba is the indigenous name of the island and in one or another form³ is encountered in all regions. Over most of the eastern linguistic area it is pronounced as Humba. According to the myth of Umalulu,⁴

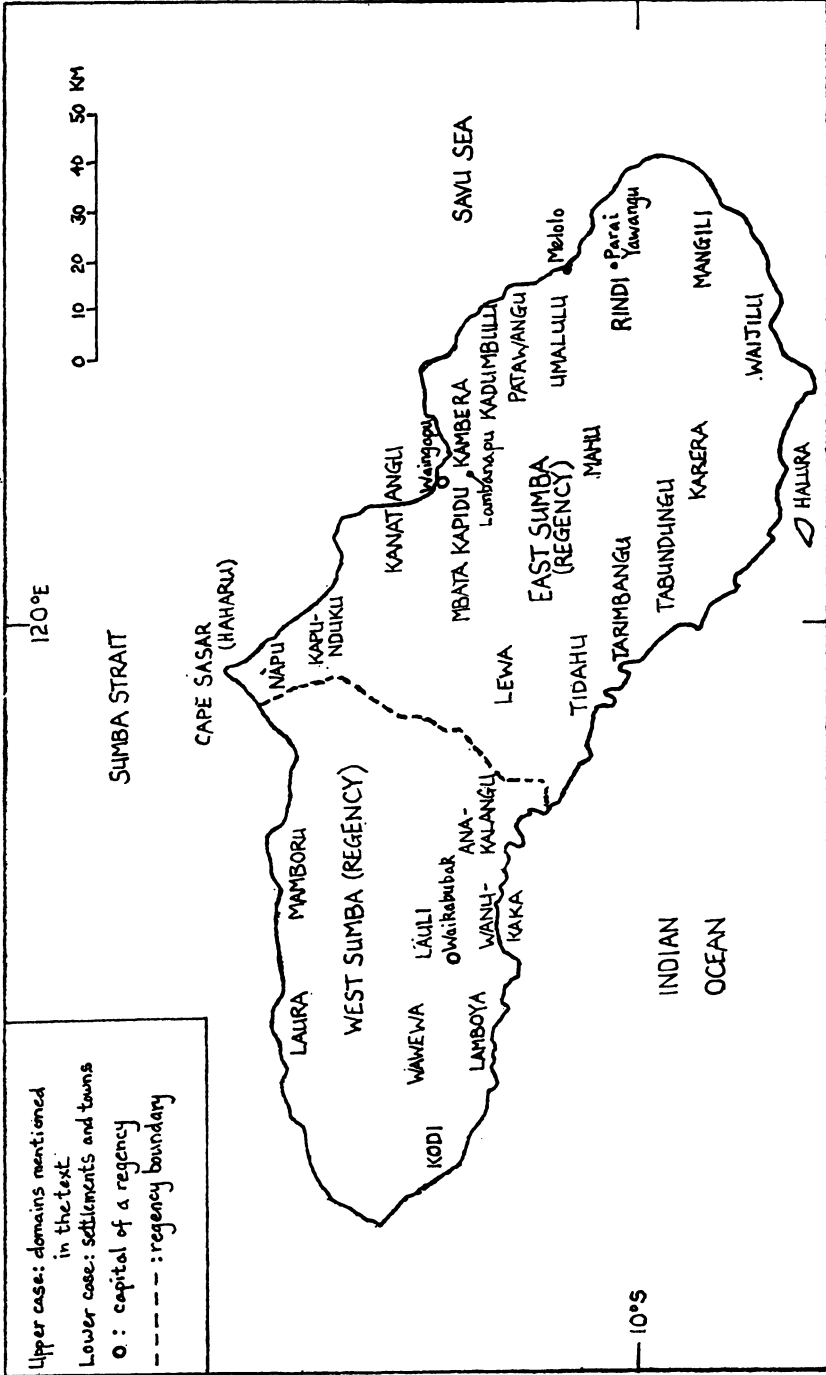

MAP 2. Sumba

the traditional domain just north of Rindi, the name was that of a woman, Kaita Humba, who was the sister of the founding ancestor of Watu Waya, the oldest of the clans presently resident in that district. While Humba is still used as a woman's name, I could find no independent meaning for the word. I would guess, however, that it might be cognate with *homba*, a word I discuss in Chapter IV; this seems to find some support in the appearance of *homba* in the man's name Tanahomba (*tana* is 'land', 'island'; see Tana Humba, 'Sumba'). Kapita (1974) gives as one gloss of *humba* (and the variant *umba*), 'brother-or sister-in-law'; but no one I questioned in Rindi had ever heard of this usage, and following a personal discussion with Kapita, it seems that the word is not used in this sense in the eastern part of the island. The domain of Rindi⁵ is named after a locally extinct clan which according to myth was the first (or one of the first) to settle there.

Sumba, and especially the eastern region, is a hot, dry, hilly and sparsely covered land; and lacking recent volcanic deposits the soil is rather less fertile than that of islands further to the north.⁶ (Hereafter I shall refer only to eastern Sumba.) Rain is almost entirely restricted to the brief west monsoon that prevails from December to March on the coast and from November to April in the interior. The yearly rainfall in these two regions averages about 1000 and 2000 mm. respectively, but is subject to considerable local and annual variation. In most areas, however, water is easily available throughout the year from the larger rivers, which originate in the mountainous districts of Mahu and Tabundungu and flow northwards and eastwards to the sea. Owing to the arid climate and irregular distribution of suitable agricultural land, the population of eastern Sumba is concentrated along the lower reaches of these rivers and in some more southerly parts of the interior. Large areas are virtually uninhabited. The most densely populated part of Rindi lies along the lower course of the Rindi river valley, and the centre of the domain is located some 6 km. from the sea. Beyond a ridge of low hills to the north, Rindi adjoins Umalulu. Much of the Rindi river valley is quite extensively cultivated. Crops are planted both on tracts of land located behind the villages, which are mostly situated close to the river, and in riverside gardens (*woka mondu*), where the soil is a sandy loam. (Rindi is rather better provided with such land than are other parts of the eastern region.) Just south of the river, the terrain rises abruptly and the relatively lush vegetation of the valley, with its many coconut palms and other deciduous trees, is replaced by a short grass savannah — a landscape typical of much of eastern Sumba

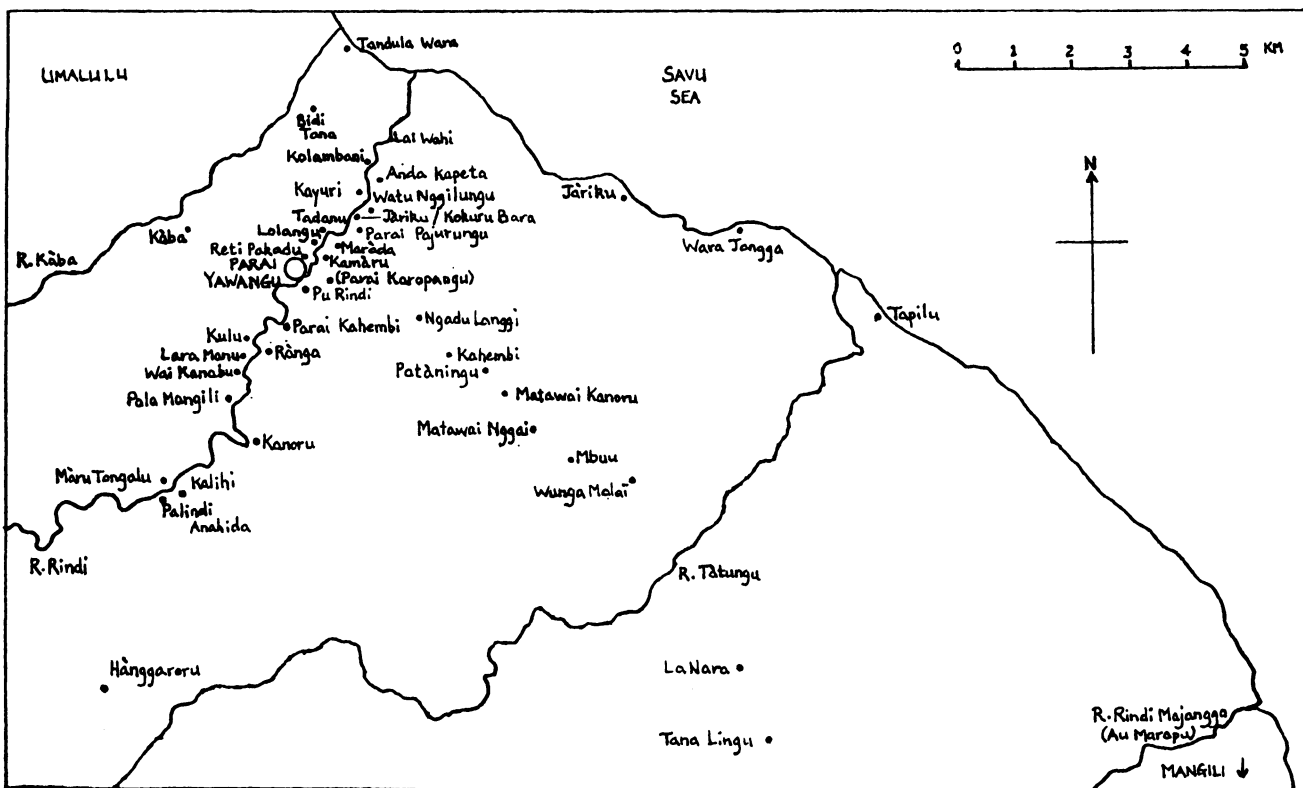

MAP 3. Rindi (core area)

(Source: Maps 78 & 79 - XLVIII, XLIX. Reproductiebedrijf Topographische dienst. Weltevreden 1930. Details of settlements corrected and enlarged by the author)

— which is cut through by several narrow streams. In this region are found extensive pastures interspersed with complexes of fields and scattered hamlets inhabited by clans whose principal villages lie in the valley below (see Chapter II). From here Rindi territory extends southwards to the river Rindi Majangga (or Au Marapu), which forms the traditionally recognized boundary with Mangili. (The Rindi village of Mau Bokulu, which seems to have been founded sometime before the turn of the century, however, actually lies just south of the Rindi Majangga. At present, moreover, nearly 300 Rindi reside in the Kabaru region, also south of the river; but this is apparently a rather more recent extension.) The upstream limit of Rindi is located perhaps 15 km. from the estuary of the river Rindi. I thus estimate the present area of the domain to be about 300 km. sq.

2. Some Themes in the History of Eastern Sumba

Limitations of space preclude me from giving a comprehensive outline of Sumbanese history; so here I shall mostly limit my remarks to several factors which appear to have significantly affected the development of eastern Sumbanese society over the last two to three centuries.⁷

Though in the fourteenth century Madjapahit apparently regarded Sumba as one of its dependencies (de Roo 1906:1-2), it is not known whether there was any direct or sustained contact between the island and Java at this time. In the seventeenth century the Sultan of Bima considered Sumba to fall within his jurisdiction, but evidence of the extent of Bima's actual influence is similarly lacking. Contacts between Sumba and the Portuguese in the Timor region were at best brief and sporadic; and due mainly to lack of interest the Dutch East India Company, though it contracted an agreement with the ruler of Mangili in 1756, also had virtually no direct or regular involvement in Sumba's affairs. In 1800 the Netherlands Indies Government took over the Company's interests in the region, but not until 1866 were officials first posted on the island, and it was only in 1912 that the Dutch, following a campaign of pacification begun in 1906, established an effective colonial administration.

The main reason for Dutch reluctance to take control of Sumba before the early part of this century was the continual feuding between native domains. This was closely linked with the slave trade carried out mainly by slavers from Ende on Flores. The extensive export of slaves, which various authors have suggested as a reason for eastern

Sumba's low population density, probably dates from at least 1700 (see Kapita 1976b:147; *Encyclopaedie van Nederlandsch-Indië* 1921-IV:4). Apart from conducting independent raids to capture slaves, Endenese slavers also participated as mercenaries in local wars, from which they received slaves as booty; and they purchased further slaves from Sumbanese rulers. Though slave raids extended far into the interior, they were naturally more concentrated along the coast; so it is possibly for this reason that the main centres of population in coastal regions are now located several kilometres from the sea. According to Kapita (1976b:18), it was also because of slave raids and internal unrest that previously more dispersed populations assembled to found the present chief villages (*paraingu*) built on elevated sites and fortified with stone walls and cactus hedges. This accords with the fact that such large settlements, and hence the more unified political territories of which they form the centres, are more prevalent on the coast than in the interior. The fact that many clans are now found dispersed throughout eastern Sumba is probably also largely due to the internal strife of earlier centuries. According to tradition, many clan segments in south-eastern Sumba derive from more northwesterly parts of the island, where the Endenese, and hence slave raids, were especially concentrated.

Another major factor in the course of eastern Sumba's political economy during the last century was the export trade in horses. Though horses were already present on the island in large numbers by the latter half of the eighteenth century (see de Roo 1906:55), systematic export on a large scale did not develop until the 1840s. This was mainly initiated by an Arab merchant from Ende, who in 1843 founded Waingapu, the port town and present capital of the East Sumba regency. By the middle of the nineteenth century, the eastern Sumbanese nobility, especially, owned large numbers of horses (see Roos 1872:28), and the very rich profits obtained by these native rulers from the sale of livestock contributed in no small measure to their power. The possession of horses was also closely bound up with the incessant local feuding, in which livestock theft played a large part, all the more so as horses were becoming an increasingly valuable commodity.⁸ While payment for horses was mostly received in coins of precious metal, however, this did not introduce a cash economy to Sumba, as the coins were made into traditional ornaments and then used as jewelry or in traditional forms of exchange, or retained as a store of wealth. The nobility of eastern Sumba still hold vast quantities of these precious

metal coins. Earlier this century, though, the export demand for horses began to decline, and cattle, first introduced in 1912, have now largely replaced horses as a source of revenue. Until quite recently, many commoners as well as noblemen in Rindi were rich in horses and other livestock. Indeed, in this century Rindi gained a reputation as the wealthiest of eastern Sumbanese domains. But since the war, due in part to epidemic diseases and plagues of worms that destroy grass, the fortunes of stock raisers have declined quite markedly. Thus whereas in 1941 the ratio of horses to persons in East Sumba was 100:134, by 1973 this had fallen to 100:235.⁹ Nevertheless, many persons still own large numbers of horses, and, as I shall later show, the animals are still important in the internal, traditional economy.

In accordance with the general lack of European involvement on Sumba prior to colonization, with the exception of a Catholic post in western Sumba (Laura) which was maintained from 1886 to 1898 Christian missions were not established among native Sumbanese until this century, thus rather later than on other islands of eastern Indonesia. Missionaries of the Dutch Calvinist Church officially began work on Sumba in 1907. Despite their efforts, however, the majority of Sumbanese, probably more than two-thirds in eastern Sumba, still retain their traditional religion; and, though Muslim Endenese have for a long time maintained relations with Sumba, including the founding of coastal villages, the number of indigenous Sumbanese converts to Islam is apparently negligible.

Another people who occupy a prominent place in the history of Sumba are the Savunese. In the second half of the nineteenth century Savunese emigration to Sumba was encouraged by the Dutch, who hoped that their presence would help check the disruptive activities of the Endenese. Frequent contact between Sumba and Savu, as well as some settlement along the eastern coast, however, well predates Dutch involvement on the island (see Nootboom 1940:7); and according to tradition the founding ancestors of several eastern Sumbanese clans derive from Savu. Inter-marriage between Savunese and eastern Sumbanese, especially between their respective nobilities, also, is reported from the last century; and Endenese settled on Sumba were also affinally connected with Sumbanese rulers (see Kapita 1976b:145).¹⁰ In Rindi, however, marriage with Savunese is uncommon, and, despite the proximity of this domain to Melolo — one of the larger and older Savunese settlements, in Umalulu territory — there were only 15 cases among 2,155 unions I recorded there. The genealogy of the Rindi

nobility, moreover, records no marriages with Savunese or other foreigners.

The Savunese maintain their own villages, located mostly on the coast, and though they now number perhaps over 10,000 in the East Sumba regency alone, they appear to have had no direct influence on traditional Sumbanese culture. Contact between Rindi people and Savunese is largely confined to the weekly market held in Melolo. By contrast to the Sumbanese, the Savunese on Sumba are all Christian and virtually all speak Indonesian; they are also very prominent in local government, education, and the health service. The Rindi generally dislike the Savunese who, with some justification, they consider brash, ill-mannered, and aggressive. Since they operate different economies (see Fox 1977), however, at present this is more a clash of personalities than of interests.

3. A Brief History of Rindi

The history of the present domain of Rindi is largely that of its ruling noble clan, Ana Mburungu. Several parts of the myth of this clan appear to be historical in nature, and are worth briefly summarizing here since they bear significantly on topics to be treated further below, in particular the relation between Rindi and its immediate neighbour, Umalulu.

Some ten generations ago, an ancestor of Ana Mburungu, Hiwa Ndapabengingu, was murdered by their enemy, the clan Palamidu; so Ana Mburungu moved to the village Parai Kakundu,¹¹ in the Kampera region, near Lambanapu. Hostilities between these two groups however continued, and later Palamidu hired Endenese mercenaries to sack Parai Kakundu. In the battle the son of Hiwa Ndapabengingu, Renggi Nggilinjuka, was captured and sold as a slave to the nobility of Tabundungu. As a slave, Renggi then accompanied his masters on a visit to their wife-takers, the noble clan Palai Malamba in Umalulu, where he encountered his sister, the wife of a Palai Malamba nobleman. With the help of other Umalulu clans, his affines paid a large ransom to Tabundungu for Renggi and returned him to Parai Kakundu. Later he took a wife from the noble clan Kaliti in Wai Jilu, the wife-giver of the earliest ancestors of Ana Mburungu.

At this time Ana Mburungu shared Parai Kakundu with the clan Karindingu. But following a dispute over a woman, a Karindingu man secretly murdered Teulu Namuparaingu, by one account a son of Renggi Nggilinjuka. The two clans thus began to feud, and Karindingu even-

tually fled to the interior, as far as Karera. Fearing future reprisals, Ana Mburungu then also evacuated the village and headed for Wai Jilu to join their wife-givers, Kaliti.¹² A segment of Karindingu eventually established itself as the ruling clan in Mangili. According to Kapita (1976b:146-47), the Mangili ruler named Làkaru Taraandungu who signed a treaty with the Dutch East India Company in 1756, was an evacuee of Parai Kakundu. This indicates, then, that the village was abandoned at the latest in the early part of the eighteenth century.

On their way to Wai Jilu, Ana Mburungu tarried in Patawangu, where the rulers of that district, the clan Lamuru, invited them to stay; but they declined. At this time, however, the Patawangu nobility gave a wife to Ana Mburungu, thus initiating a marriage alliance that is maintained to the present day. They then moved on to Umalulu, where they were offered land and a secure place within the chief village by Palai Malamba and the religious rulers (*ratu*) of that domain. Accepting the offer, Ana Mburungu thus remained in Umalulu for three generations, during which they began to take wives from the Palai Malamba nobility.¹³ In the time of Nggala Lili Kaniparaingu (the SSSS of Renggi Nggilinjuka), however, Ana Mburungu became involved in another dispute, which caused them to remove to Matawai Katàba in Mangili territory. It was then later decided by the leaders of Mangili and their counterparts in Umalulu that the Ana Mburungu nobility should establish a domain of their own somewhere between these two districts. Thus the present chief village of Rindi, Parai Yawangu, was founded in the valley of the Rindi river.

Rindi seems to have thus emerged as an independent domain under the leadership of Ana Mburungu sometime between 1800 and 1850. It was certainly established before 1862, since among the names of the domains recorded by Esser (1877:161) during his visit to Sumba in that year is 'Rende or Anaboro'.¹⁴ Prior to the arrival of Ana Mburungu, Rindi seems to have been a marginal area with little political unity. Just beyond the escarpment to the south of the river, a few old graves, now long since plundered, are all that remain of a former village called Parai Karopangu. This, I was told, was abandoned long before Ana Mburungu entered the area. The village is said to have been inhabited by several clans which later moved southward to Mangili.¹⁵ The clan Rindi, which was also once established there, seems to have been virtually extinct when Ana Mburungu arrived, though some older people claim still to remember persons of that clan. Of the clans now resident in Rindi (see Appendix II), Dai Ndipi, Kanilu, Karambu, Kati-

nahu, Mahora, Wanga, and possibly a few others were settled there before the founding of Parai Yawangu. Only Dai Ndipi, however, has its traditional homeland in the area. This was a village in the Hånggaroru region called Pindu Watu-Parai Karuku, which has now long been abandoned.

Under Ana Mburungu, Rindi quickly gained a reputation as a powerful and belligerent force among the eastern Sumbanese domains. Wielenga (1949:27) thus describes the ruler of Rindi towards the end of the last century as 'the most powerful prince in East Sumba',¹⁶ and the domain is mentioned in several Dutch reports from this time. In 1895, Rindi summoned Umalulu and Mangili to join forces against their long-standing common enemy, the interior domain of Karera (Parai Witu), as a reprisal for continual horse theft (Kapita 1976b:39). The Rindi ruler, Hina Marumata,¹⁷ is again mentioned in a report of 1900, during which year his troops plundered and burned the village Yalangu in Mangili, including a school founded in the previous year by the missionary Pos, and took many captives (Kapita 1976b:40). In 1901 Rindi was also implicated in the so-called Lambanapu war, a punitive expedition by the Dutch against the ruler of Lewa, which resulted in their taking direct control of the island. According to Wielenga (1949:27-28), the Lewa ruler (whose brother's wife was an Ana Mburungu noblewoman) at this time sought the support of the Rindi ruler for his plan to expel all foreigners from the island. Later in 1901, after the Lambanapu incident, the Dutch warship Java anchored in the Rindi estuary and the Rindi ruler was requested to come aboard to speak with the Resident (Commissioner) from Kupang; but the ruler sent his son and a brother's son in his place. When the Resident questioned these men about the above-mentioned raid on Yalangu, they admitted their involvement, agreed to surrender all captives, and to pay 2,500 rupiah in damages. This was discharged straight away (Kapita 1976b:42). Like the other coastal domains, but in contrast to some in the interior, Rindi put up no resistance during the Dutch pacification of 1906-1912.

In 1912 the Dutch divided what is now the East Sumba regency into nine 'sub-departments' (Du. *onderafdeelingen*), later called in Indonesian *swapraja*, 'autonomous regions'. Each was governed by the headman of a local noble clan appointed to the mostly hereditary position of 'independent administrator' (Du. *zelfbestuurder*) or '*raja*', and most comprised two or more formerly independent traditional domains.¹⁸ This system continued under Indonesian rule until 1962, when East Sumba was divided into (eventually) six 'sub-districts' (Ind.

kecamatan), each administered by an official, or *camat*, appointed by the government. In 1912 the northern part of Mangili was joined to Rindi to form the sub-department of Rindi, headed by the Rindi noble ruler, Hina Marumata; later all of Mangili was annexed to Rindi. Since Rindi was thus able to preserve its unity under the leadership of its traditional rulers, its internal polity was less affected by the colonial administration than was that of some other domains. The last Rindi raja, Hapu Hambandima (Hina Marumata's grandson), died in December 1960 and was briefly succeeded by his closest male heir of suitable age (his FBSS), Tunggu Mbili. Less than two years later, however, the new form of administration took effect. Tunggu Mbili, an educated man, is now a civil servant and resides in Waingapu.

4. *Demography and Modern Administration*

In 1971 the East Sumba regency had a population of 103,519, which included perhaps as many as 13,000 non-Sumbanese (mostly Savunese). The population density was 13.4 per km. sq., thus by far the lowest in Nusa Tenggara Timur province and among the lowest anywhere in Indonesia. Between 1961 and 1971 the population increased annually by 0.91 per cent. This is the second lowest rate among the province's 12 regencies and very low by general Indonesian standards;¹⁹ and judging by Wielenga's (1949:38) figure of 74,000 for the early thirties, it has remained more or less constant over forty years. The low rate of increase is probably due, as the Rindi themselves claim, mainly to low fertility. Traditional and educated informants suggested several reasons for this, including venereal disease, late marriage, abortion, and the use of indigenous contraceptive medicines. Lacking adequate information on how extensive or relevant these factors might be, however, I am not qualified to assess the likely causes for eastern Sumba's remarkably low population growth rate.

In 1962 Rindi, Umalulu, and Patawangu were combined to form the *kecamatan* or sub-district of Rindi-Umalulu, which was then divided into 15 *desa*. While the usual translation of this Indonesian word is 'village', it refers here to the lowest level of modern government administration, which in the case of East Sumba typically comprises many small traditional villages and can encompass an area of between 50 and 100 km. sq.²⁰ This new form of organization, however, seems yet to have had no great effect on Rindi life: it has not caused major changes in settlement pattern or relations between local (descent) groups; and

virtually all the men elected as *kepala desa*, 'village headman', have been persons who are also prominent by traditional criteria, such as class standing and wealth. Rindi itself is now divided among five of the component *desa* of *kecamatan* Rindi-Umalulu — Rindi (Parai Yawangu), Tamburi, Kayuri, Hånggaroru, and Haikatapu — and Rindi people form the largest part of *desa* Kabaruu in the *kecamatan* Pahunga Lodu to the south. Some of these *desa*, however, overlap the boundaries of the traditional territory of Rindi. In 1976 the combined population of the six areas was 4,503,²¹ which included approximately 413 Savunese, 156 Endenese,²² 49 Sumbanese outsiders (school teachers, evangelists, and their families), and 27 other outsiders mostly resident in Kabaruu. There were also 319 members of Mahu clans living in the interior parts of Tamburi and Hånggaroru, another 48 recent migrants from Umalulu settled in the latter *desa*, and 29 Mangili people in *desa* Kabaruu. If all of the above are subtracted from 4,503, then the total number of Rindi people (i.e., members of Rindi clans, plus affines from elsewhere, resident in Rindi territory) was 3,462.²³ According to an anonymous report (1933:5), the population of Rindi in 1931 was an estimated 2,371. If this is accurate, it has increased since then by an annual rate of 1.02 per cent, which is thus not significantly higher than that for East Sumba as a whole.

5. *Subsistence and Economy*

The staple in Rindi, as throughout eastern Sumba, is maize (*wataru*). Other crops include wet and dry rice (*uhu*); various tubers (cassava, sweet potatoes); peanuts; several varieties of pumpkins and gourds; spinach; and other vegetables, most of which are not extensively or regularly cultivated. On the whole, the Rindi vegetable diet is rather unvaried, and they regard green vegetables as inferior foods. Very little sorghum (*wataru hãmu*) or millet (*uhu kani*) is planted in Rindi, though these crops are more common elsewhere.²⁴

Most crops are planted on dry fields. Irrigated rice land, which is found only in a few better watered areas near the coast, is owned mostly by the nobility. Swidden agriculture (*kanguma*) is not extensively practised in Rindi and is now restricted by the forestry commission; so most crops are cultivated on more permanent fields.²⁵ The major maize crop of the year is planted in December, about the same time as dry rice, tubers, millet (often planted in the same fields as dry rice), and other crops, and is harvested in March or April. A second

crop is then planted in both riverside gardens (*woka mondu*) and higher lying fields (*woka kamara* or *tana dita*). After this is harvested, about August, yet a third maize crop may be planted.²⁶ Planting of traditional strains of wet rice (*uhu Humba*), the sorts preferred for religious offerings, takes place in April, and the harvest is in September or October. The now more common, introduced varieties, which take about half as long to mature, however, may be planted any time between March and June.

The major fruit-bearing trees are coconut palm, papaya, mango, tamarind, and many species of banana. Coconut shell has many uses, including the manufacture of vessels and ladles. The leaves of the fairly plentiful lontar palm (*menggitu*) provide material for plaiting mats and containers, and the wood is used for flooring; but the juice of this tree is hardly ever tapped, and by contrast to neighbouring islands, lontar tapping seems not to have been a traditional practice on Sumba (Anon. 1855:304). Other useful plants include the gewang palm and pandanus tree, the leaves and spines of which are used for plaiting and binding; the *huwa* tree, the bark of which provides a sturdy rope; the madder tree (*kombu*), *Cudrania spinosa* (*ai iju*), and indigo, from which dyes are obtained; bamboo; rotan; and a variety of hardwoods used in house construction. The leaves of various wild plants and trees are occasionally eaten as side dishes.

Besides horses, which in the internal economy are used as bride-wealth and transportation, livestock comprises buffalo, pigs, domestic fowls, goats, and, recently, cattle; goats, though, are not particularly common in Rindi. Despite their great love of meat, the Rindi slaughter animals only on ritual or festive occasions. Pigs, chickens, and buffalo (which, of course, are also used in wet rice cultivation) are the main sacrificial animals. Horses and goats are also slaughtered in some ritual contexts, but only the meat of young horses is consumed. Cattle are not used as sacrifices. Though a few rites require the slaughter of a dog, the carcass is then never eaten. Interestingly, while the Rindi say that dogs were formerly killed to provide ritual meals, particularly for wife-giving affines, many people at present deny that they ever partake of the meat.²⁷ The reason given for this change was that eating dog meat is now regarded as a sign of poverty. It may also be relevant, however, that this practice is closely associated with the generally disliked Savunese, who relish dog meat and provide the Sumbanese with a ready market for well-fed dogs.

Salt-water, and some fresh-water, fish; crustaceans; and other

products of the sea form an important part of Rindi diet.²⁸ Deer and wild swine are occasionally hunted, but hunting does not contribute significantly to Rindi subsistence.

Men's crafts include the manufacture of rope, fish nets, and a variety of utensils from wood and buffalo horn. A few men practice smithery, but the manufacture is then largely confined to metal ornaments. The bulk of these comprise gold, silver, and tin *mamuli*, which I shall hereafter refer to as 'pendants', and plaited chains made mostly of copper wire. These objects, which are further described in Chapter XVII, form a major component of prestations given by wife-taking affines and other customary payments; so I shall often need to refer to them later. Most utilitarian items of iron and other metals, and gongs, are now obtained by purchase.²⁹ Women's crafts include the weaving of elaborately decorated textiles, plaitwork, and pottery. The decorated textiles are used mainly as a counter-prestition to bride-wealth, and in terms of bulk, elaboration of design, visual appeal, and technical and artistic skill are by far the most prominent form of material art. Ornamental work in wood, stone (namely, carving on graves), metal, tortoise shell, and ivory, which is all done by men, on the other hand, is in most of these respects noticeably less developed. I shall return to this contrast shortly.

Men's clothing in Rindi, as in eastern Sumba generally, consists of a loin-cloth (*hinggi pakalambungu*),³⁰ a shoulder cloth (*hinggi paduku*), a head-cloth (*tera*), and nowadays usually a shirt. The loin-cloth and head-cloth are wrapped anti-clockwise (as viewed from above) around the body; the significance of this rule will be made clear later. Women wear a long tubular skirt (*laili*) and at present, on more formal occasions, a blouse. The traditional woman's head-cloth (*tera tamali*) is worn infrequently in Rindi. Both men and women sometimes wear wide-brimmed or conical hats of plaitwork while working in the fields. Most Rindi clothing for daily wear is now made from purchased cotton or synthetic material, and the locally woven decorated textiles are worn for the most part only on ceremonial or festive occasions.³¹ As regards style, however, they have largely retained their traditional dress, though recently some younger men have adopted the familiar Indonesian sarong for ordinary wear. Formerly, I was told, the Rindi preferred black clothing. Nowadays most women's skirts are still black (or dark blue, green, or other shades they classify as 'black', *mitingu*), while men's garments tend to be somewhat more variously coloured.

Cash has entered the Rindi economy mainly through the sale of live-

stock; and a number of items — including coffee, sugar, lamp oil, and soap — are now regularly purchased, mostly from several Chinese merchants in Melolo. For about the last thirty years there has also been a weekly market, at present held in Melolo, to which the Rindi take coconuts and coconut oil, betel and areca, dried fish, and in some months, foodstuffs. This they sell to Savunese and other non-Sumbanese and to people from other domains. Among the products the Rindi regularly obtain from the market are salt and lime, which they themselves now produce much less of than formerly. While the market has not obviated traditional patterns of reciprocity among agnates and local affines, it has led to a decrease in the seasonal trade called *mandara*, carried out in the months prior to the first maize harvest, when food from the previous year is in short supply. Coastal people would then travel inland taking local products to exchange, preferably with affines resident there, for staples available from the earlier interior harvest. Nowadays, of course, food is usually available from the market or from merchants. Recently, the government established a cattle breeding project just to the south of Rindi, and some younger Rindi men now engage in casual wage labour there for brief periods. (The permanent employees are nearly all non-Sumbanese.) This, however, has yet to have any marked effect on the Rindi economy or on their pattern of life in general.

6. *Language*

The eastern Sumbanese call their language Hilu Humba (*hilu*, ‘language, dialect’, also means ‘to reciprocate, change, exchange, replace’). The major dialect of the eastern region is Kambera, named after the traditional domain close to Waingapu. Due mainly to the export trade in horses centred in Waingapu during the last century, the dialect has become a *lingua franca* in eastern Sumba, and the name Kambera has since come to be applied to the eastern linguistic region (which extends further east than the present East Sumba regency) as a whole.³² Rindi speech, or Hilu Rindi as it is occasionally called, is recognized to be identical to that of Umalulu and differs only slightly from the language spoken in Mahu, Kadumbulu, and Kambera itself. A few Rindi words, however, follow the pronunciation of Mangili, which, with Wai Jilu, forms a dialect distinct from Kambera.

In transcribing the language I have employed the orthography of Kapita (1974), which follows modern Indonesian by incorporating the

changes in Indonesian spelling adopted in 1972.³³ The main change is that *j* is now written as *y*; thus former *dj* = *j*, *ndj* = *nj*, and *nj* = *ny*. The following remarks on phonology will mostly concern the transcription of similar sounds that affect meaning. Kambera is a semi-vocalic language. Though eight of the 19 consonants can appear at the end of a word, when this is followed by another word or particle the final consonant is sounded with a short *u*; thus in writing, all words end with a vowel. There are long and short forms of *a*, *i* and *u*, but since only the two *a* sounds are frequently or regularly phonemic, I have found it necessary to distinguish these alone. The short form, *à* (pronounced roughly as in English 'pun') is thus written with a grave accent; the long *a* is as in English 'father'. An umlaut is used to differentiate the diphthongs *aï* and *aü* from *ai* and *au*, which are nearly pure sounds. The stress in Kambera generally falls on the penultimate syllable and in two-syllable words on the first, except where a word ends in a terminal consonant, in which case stress is unaffected; thus in both *puru* and *purungu* the accent is on the first syllable. With certain two- and three-syllable words where the final syllable is voiced with a long *a*, *i* or *u* sound, however, it is this syllable which is stressed, since in these cases the final syllable can be seen originally to derive from two (e.g., *panii*, Kambera, *panewi*, Mamboru, 'to speak'; see also Onvlee n.d.: 2).³⁴ Such vowels, therefore, are reduplicated: thus *aa*, *ii*, and *uu*.

Six consonants require more than one roman letter. *Mb*, *nd*, *nj*, and *ngg* are prenasalized (Onvlee 1973:168); so the first three contrast phonemically with *b*, *d*, and *j*, which are pronounced without aspiration. With *d* the tongue is also placed rather higher than with *nd* (the English 'd' would mostly be heard as *nd*). The *j* sound is a palatalized *d* ('dy'). In Rindi, the *w* is closer to the English 'w' than to 'v' (or the Dutch *w*), except sometimes in medial positions. The former *s* in Kambera has been replaced with *h*. The shift seems to have occurred fairly recently, since earlier this century Wielenga (1917:4) reported that the *s* was still 'readily used' by older people and, by implication, by some younger ones as well; and many Dutch writers both before and after this time regularly use *s* in transcribing Kambera words. In Rindi the *s* (usually pronounced as 'sh' or 'sy') is still occasionally, though rather inconsistently, used by some older men in ritual speech and song, and the interjection *ha* is sometimes uttered as 'sya'.³⁵

Apart from ordinary speech, the eastern Sumbanese have a formal ritual language which, as elsewhere in Indonesia (see Fox 1971a:215-55), is characterized by extensive parallelism and an oblique, abstruse,

and formulaic mode of expression. Though parallel speech can be called *luluku* ('straight', 'continuous', evidently from the partly synonymous *lulu*, also meaning 'long', 'thread', 'string'), this term specifically refers to the speech of the *wunangu* (also 'shuttle comb on a loom'), ritual speakers who carry out formal negotiations between affines and other parties. The same speech form, however, is just as much used by 'priests' (*amabokulu* or *mahamayangu*) to address or invoke spirits, performances called *hamayangungu*, or 'liturgies', and to a lesser degree in songs, myths and, occasionally, in everyday speech. The speech of the *wunangu* (i.e., the *luluku*), especially, is further characterised by great rapidity, fluidity, and repetition, single speeches sometimes continuing for ten minutes or more. Though many terms in ritual language are ones in ordinary use, some are exclusive to this idiom; and many of these are taken from other dialects. The words and phrases are regularly grouped in pairs, so that each component has a 'partner' (*papa* or *ndekilu*), and then further conjoined to form sets of four, six, or more units. Dyadic sets, I was told, thus each comprise a male and female member; and the purpose of doubling is so that if the addressee does not take the meaning of the one component the other will make good the deficiency. Accordingly, many paired terms and phrases comprise synonyms, though other principles, such as complementarity, metonymy, and antithesis, can also be found. A unitary utterance is called the *kajangu*, also 'screen', 'umbrella', of its referent, which thus suggests that its purpose is to shelter or disguise that to which it obliquely refers. While the combination of terms and phrases is mostly fixed by custom, and particular phrases are appropriate only in a limited number of ceremonial contexts, one also finds a good deal of individual stylistic elaboration; and recitations performed at different times or by different speakers can vary considerably both in length (due mainly to the extent of repetition) and composition.

As Rindi ritual language provides a rich source of symbolic associations I shall frequently have occasion to cite passages from it in the chapters that follow. Indeed, the language forms the major content of what can be called rites in Rindi, since, apart from slaughtering animals and disposing offerings, there is very little that is physically done on such occasions. As noted, the major material art form is the weaving of decorated textiles, which activity is exclusive to women. Performances in ritual speech (i.e., *luluku* and *hamayangungu*) and in fact nearly all ceremonial activities, on the other hand, are carried out only by men. In this regard, then, there is a clear association of males with

verbal modes of expression and females with visual ones. Because textiles are much more restricted as media of symbolic expression and appear in a much smaller range of ritual contexts, however, in the more general view, Rindi, and eastern Sumba generally, can be described as mainly a verbal as opposed to a visual culture.³⁶

7. *Fieldwork*

Shortly after our arrival in Waingapu on 10th January, 1975, my wife and I visited various parts of eastern and western Sumba in order to select a location for fieldwork. We eventually chose Rindi, first of all because it was in the region where prescriptive alliance had been reported. I also knew that the dialect there was little different from standard Kambara, and I wanted to work in a place where the majority of the people still adhered to the traditional religion. In this latter respect, especially, Rindi turned out to be ideal, since some 95 per cent of the population, including the traditional rulers, were neither Christian nor Muslim. Two further advantages of Rindi were that, by contrast to some other domains, its chief village, Parai Yawangu, was still inhabited and, as the Dutch-built road from Waingapu runs just below this village, communications were easier there than they would have been elsewhere.

After an initial stay of two days in Rindi in January 1975, which provided some opportunity to investigate whether the Rindi were as traditional as we had been told in Waingapu, we moved to the domain on 7th February and remained there until 21st December, 1976, thus for a period of over 22 months.³⁷ Following a request from the regional government in Waingapu, shortly after our arrival the *kepala desa* in Parai Yawangu (at that time the senior man of the noble clan Ana Mburungu) arranged for a wood and thatch house that some years before had been occupied by a school teacher, to be renovated and made ready for us. We moved in some three weeks later. The building was conveniently located just below the main gates of the chief village, and though, lacking a raised floor, it was not a traditional house, it allowed us to live simply, in a way not out of keeping with that of our Rindi neighbours.

During the next two years we lived as much like the Rindi as our circumstances permitted. We obtained our food locally, cooked on a wood fire, lighted our house with oil lamps, obtained water from the river (which, however, we boiled), and kept chickens and the occasional pig.

We also adopted Sumbanese dress and acquired horses for travel. Initially, the *desa* ('village') council assigned two young Rindi men to watch over our house and possessions (a most necessary precaution as it later turned out³⁸). Later, one of them (Woha Waluwanja, who I mentioned in the Preface) moved in permanently and with the help of his wife and children took over the daily running of the household for us. During our time in Rindi we had little contact with non-Sumbanese and, though the island is now becoming more accessible to young tourists, very few contacts with Europeans.

As the language was to be both the medium and an important focus of our study, our first task after moving to Rindi was of course to gain a working knowledge of Kampera. This was all the more necessary as the majority of older Rindi people have at best a poor knowledge of the national language and many have none at all. At first, access to their language was necessarily through Indonesian. Though we had studied Indonesian on our own in England, by the time we arrived on Sumba we were still rather less fluent than would have been useful. But during our first several weeks on the island our facility improved rapidly; so by the time we moved into our house in Rindi we had little difficulty in communicating with young Indonesian-speaking associates. Before leaving England I worked through the Kampera grammars by Wielenga (1909a) and Onvlee (*Lessen Kamperaas*, n.d.), but before moving to the field I had only a rudimentary acquaintance with the vocabulary and scarcely any ability in the spoken language. My practical knowledge of eastern Sumbanese was therefore acquired entirely in Rindi; and towards the end of 1975 I was able to carry out my investigations in that language alone.³⁹

In fieldwork one inevitably encounters problems specific to the locale and culture concerned. One difficulty for anyone working in eastern Sumba is the low population density and the fact that settlements are rather dispersed; thus it was not always easy to contact people with whom we wished to speak, and we often had to spend long hours travelling in order to do so. The possibilities of any ethnographic investigation, of course, also depend to a great extent on the receptivity and general character of the people themselves. While I have not discussed in any systematic way what could be called the Rindi ethos (see Bateson 1958), therefore, it is worthwhile to give some brief indication of 'what the Rindi are like' and how this may have affected our efforts. The Rindi on the whole are a very conservative people.⁴⁰ As is shown by their retention of their traditional religion

despite decades of missionary effort, and their slowness relative to other eastern Indonesians to participate in modern educational and governmental institutions, the Rindi are generally averse to change and suspicious and mistrusting of outsiders and 'foreign' ways. They also tend to be distrustful of one another, cynical about other people's intentions, and cautious and undemonstrative in inter-personal dealings.⁴¹ This is consistent with a general indirectness observable in their culture. Despite their considerable facility for verbal expression, moreover, the Rindi are a reserved, taciturn, and secretive people.⁴² They also have a self-acknowledged tendency to obduracy (*katiku watu*, 'stone-headedness'; see Ind. *kepala batu*) and contrariness.⁴³ To balance this description, however, I should also point out that Rindi people are by no means totally lacking in kindness, generosity, and good humor (though jocosity, especially, is not generally valued among them); they also have a strict code of hospitality. Nevertheless, by virtue of the traits I have mentioned, gaining a measure of acceptance among them (other than as honoured guests) was probably more difficult and took longer than it would have done among some other Indonesian peoples. The Rindi also strictly view certain aspects of their culture, e.g., ancestral myths and other religious knowledge, as weighty matters that can only be discussed on a few special occasions; and it may be that I would have obtained more information on some of these topics had I worked elsewhere. But this is a difficulty many ethnographers must face, and though the Rindi are probably rather less flexible in this respect than some other peoples, it is perhaps only a question of degree. Furthermore, while it must be admitted that many people had at best a passive interest in our project, most were appreciative of our attempts to understand their culture and to learn their language, and not a few gave us considerable help. I would not therefore wish to appear in any way disparaging of their tolerance and forbearance.

CHAPTER I

THE HOUSE

The Rindi house is a microcosm which in its structure expresses categories and principles with the widest application in Rindi thought and action, and so provides a comprehensive representation of orderly, universal forms and relations. Since, as I shall later illustrate, both life and death begin and end in the house, it can be regarded, moreover, as the centre of the macrocosm for the group with which it is associated. The house thus provides a useful place to begin an analysis of the totality of social and conceptual order in Rindi.

1. Types of Houses

While all Rindi houses (*uma*) are constructed according to the same basic design, with regard to form two main types are distinguished: the *uma mbatangu* and the *uma kamudungu*. The first term denotes a house with a triangular peak or tower built in the centre of the roof construction, in which the relics consecrated to the clan's deified ancestor (*marapu*) are kept. It is this type of building that has been identified in the literature as the typical Sumbanese house. *Mbatangu* otherwise means 'bridge'. The suggested identification of this sort of house, and its most distinctive feature, with a bridge is perhaps to be understood with reference to the idea that the clan ancestor, like the objects that signify his presence in the house, is an intermediary between man and God. The other type of house, as it lacks a tower, is called simply a 'bald, bare house' (*uma kamudungu*). Such a building may in other respects be identical to a peaked house or the design may be further simplified and abbreviated, as I shall mention below.

A house that contains a clan's ancestral relics is also designated *uma marapu*, which hereafter I shall refer to as the ancestral, or senior, house of a clan. In ritual speech the building is called 'his (the ancestor's) shelter and place' (*maü pangiana*). While, in principle, all ances-

tral houses should be provided with a peak, in a few instances an *uma kamudungu* with a loft below the centre of the roof served this purpose. By virtue of its religious significance, the ancestral house and the village in which it is located serve as the centre of the clan within the domain. Being also the oldest house, from which all clan members are said to derive, in relation to other houses it is thus regarded as their *pingi*, 'trunk', 'source', '(place of) origin'. The ancestral house is further distinguished as the *uma bokulu*, 'big house', referring both to its generally larger size and its importance as a clan temple and common meeting place.

All other buildings owned by members of a clan, whether located in the same or in subsidiary villages, are in contrast called *uma maringu*, 'cool houses'.¹ As these are nearly always built without a peak, the Rindi thus tend to identify a peaked house as an ancestral house, and a 'bare house' as a cool house. But there were a number of houses belonging to the nobility and wealthy commoners in Rindi which, though provided with a peak, did not serve as ancestral houses and were therefore designated as cool houses. In this respect, I was told that to build a house to this design might also be done simply to express the wealth and standing of the group concerned.

In part, the adjective 'cool' (*maringu*) indicates that such a house is not given over to religious matters that concern the ancestor and serves solely the mundane needs of its occupants. Various prohibitions that apply to an ancestral house, therefore, need not be observed or are not so strictly enforced in other buildings. In formal speech a cool house is called an 'extended verandah, house that is added' (*bangga pakajowa, uma papakiku*), thus suggesting the building to be a mere extension of the older, ancestral house. Accordingly, in Rindi thought the various houses of a clan are indeed one; and I commonly found, when asking about a person's usual residence, that his clan's ancestral house would be indicated, whereas in fact he lived permanently in another village and rarely visited this house. Although major ceremonies that concern the entire clan should take place in the ancestral house, moreover, in minor rites, or whenever it is necessary to do so, it is possible to invoke the ancestor in any house of a clan member. Thus in the several cases where a clan's ancestral house had fallen into disrepair, the religious life of the group was for the most part little affected. Nevertheless, it is felt that for the performance of certain major ceremonies this house should be restored.

2. *Form*

All eastern Sumbanese houses are rectangular in shape. The two shorter and the two longer sides are called respectively the *ana uma* and *bai uma*. *Ana*, 'child', is also used to indicate a small quantity or version of something, while *bai*, when applied to animals, denotes a mature female or 'mother'.² It can also mean 'big, major', and is often used as an emphatic.³ As I shall further illustrate below, therefore, the shorter sides are indicated to be symbolically inferior to the longer ones. In Rindi, the shorter sides of the building are generally situated at the front and back of the house, and with an ancestral house this is prescribed. The arrangement, which is expressed as *hanambangu ana*, 'to have a short side at the front', is also observed in Umalulu and Mangili, while in other parts of eastern Sumba, further to the west, it is the longer sides which appear at the front and back (cf. *hanambangu bai*, 'to have a long side at the front'). In both cases, however, the narrower, triangular faces of the peak run parallel to the shorter sides of the building; so in Rindi these are found at the front and back. Between the two regions, therefore, the house is as it were turned at an angle of ninety degrees.

With reference to the position of the longer sides, the Rindi describe houses in more westerly parts of Sumba as *uma malai*, 'long houses'. A few buildings in Rindi, located mostly in hamlets near wet rice fields, which are used to accommodate harvesters and to store rice, also follow this form; and the *uma aü*, 'hearth house', occasionally built behind a residential house when it becomes too full, and which then serves mainly as a place to store domestic utensils and prepare food, is also constructed in this way. The orientation of the house with reference to the sun and other parts of the village is discussed in the next chapter.

3. *Structure*

The following description refers specifically to a peaked house (see Fig. 1 and Plate 1). The largest house in Rindi, which is the ancestral house of the noble clan, covers an area of nearly 300 square metres. Other buildings are considerably smaller than this, the smallest peaked houses having less than one half this area. The length of a side is roughly estimated in *râpa*, the breadth of the outstretched arms; and the ratio of longer to shorter sides is generally about 5:4. In all houses, the floor (*kaheli*) is raised to a height of over one metre on wooden

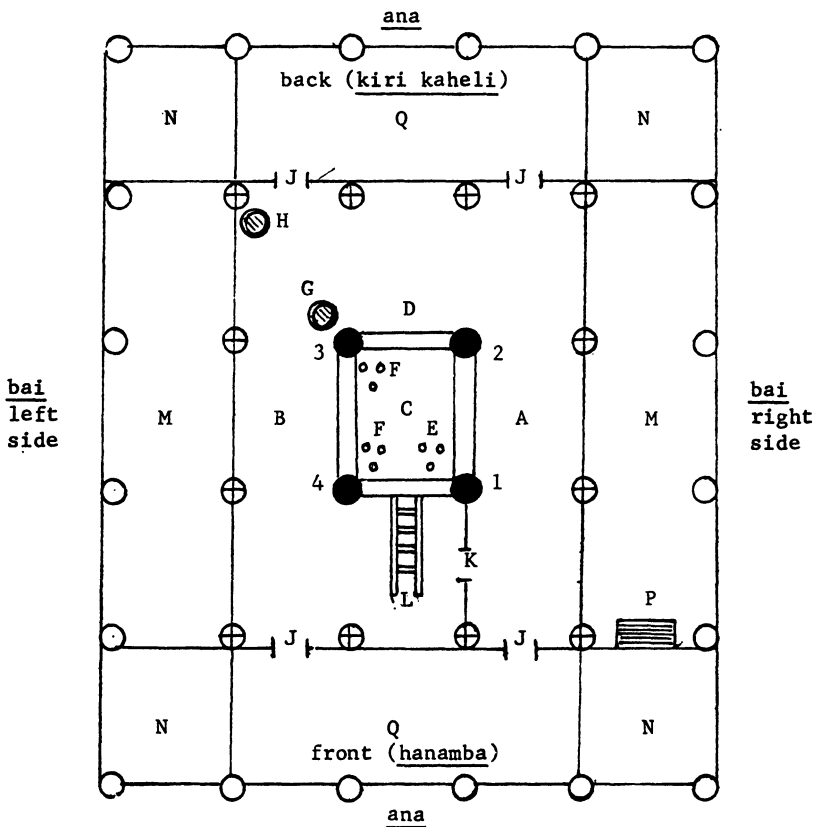

FIG. 1. Floor Plan of an Ancestral House (*Uma Marapu*).

- | | |
|--|---|
| ● main posts (<i>kambaniru lundungu</i>) | ⊕ secondary posts
(<i>kambaniru hawunjilu</i>) |
| 1. <i>kambaniru uratungu</i> | ○ tertiary posts
(<i>kambaniru lambanapu</i>) |
| 2. <i>kambaniru mapaberingu</i> | J doorways (<i>pindu</i>) |
| 3. <i>kambaniru matungu</i>
<i>uhu wei, pàni manu</i> | K hatch (<i>ngaru domuru</i>) |
| 4. <i>kambaniru mataku</i> | L ladder (<i>panongu</i>) |
| A big floor (<i>kaheli bokulu</i>) | M interior platforms (<i>nggala</i>) |
| B cool floor (<i>kaheli maringu</i>) | N exterior platforms (<i>nggala kambàku</i>) |
| C hearth (<i>aü</i>) | P rack (<i>hindi maringu</i>) |
| D hearth lining (<i>kadu aü</i>) | Q verandahs (<i>bangga</i>) |
| E male hearthstones (<i>tuluru mini</i>) | |
| F female hearthstones (<i>tuluru kawini</i>) | |
| G ancestral water jar (<i>mbàlu marapu</i>) | |
| H female water jar (<i>mbàlu kawini</i>) | |

piles. With reference to the single, central hearth (*aii*, also 'ash'), the interior of the building is conceptually divided into two halves, the *kaheli bokulu*, 'great house floor', to the right as one faces the front, and the *kaheli maringu*, 'cool house floor', also called simply *hapapa kaheli*, 'the other side of the floor', to the left. In conjunction with the distinction of front (*hanamba*) and back (*kiri ulu*) the terms thus define a four-fold division of the building. For convenience, I shall hereafter refer to the *kaheli bokulu* as the right side, thus assuming a position facing the exterior front of the house. The question of laterality is discussed further below.

The skeleton of the house consists of a series of posts, *kambaniru*, which extend from the ground to the roof construction. The four innermost posts, which encircle the hearth, are called *kambaniru lundungu*. *Lundungu*, '(to go) straight through', 'to reach', refers to the fact that these posts, the tallest in the building, extend as far as the base of the house peak. The posts should be erected in a fixed order. The first to be placed is the *kambaniru uratu(ngu)* at the right front corner. *Uratungu* means 'to divine', 'to perform religious service', i.e., to address and make offerings to the clan ancestor and other spiritual beings, which activity always takes place in this part of the house.⁴ During a rite, the priest sits just to the left of this post facing towards it. The post is thus also called *mauratungu* (*ma* is the relative pronoun), which further refers to a person who conducts rites (see Kapita 1976a: 36). The second post to be erected is the one at the right back corner, called the *kambaniru mapaberingu*, 'the post which divides', since this is the place where men butcher the carcasses of sacrificial animals. The third, at the left back corner, is the *kambaniru matungu uhu wei*, *pàni manu*, 'post that feeds the pigs and chickens', which name refers to this section of the house as the usual place of the women, who are charged with the care of these animals. The pig troughs and hatching baskets are usually kept beneath this part of the building. The final post to be erected, then, is the one in the left front corner. This is called the *kambaniru mataku*, 'post which scoops (the rice)', since it is in this part of the house that the women cook and serve the offering rice, which is passed over to the priest on the other side of the building near the *kambaniru uratungu*. While simpler, residential houses (i.e., *uma kamudungu*) sometimes lack this clearly defined central core of four *lundungu* posts, when used for ritual purposes this same quadripartite division of ceremonial and temporal activities is nevertheless retained in respect of the four quarters of the building.

The four main house posts are thus placed consecutively in an anti-clockwise arrangement around the centre of the building. This procedure is described as *palua kawanangu*, 'to move (or do something) to the right', a phrase which defines proper order in a variety of contexts in Rindi. With regard to house construction and other matters, the same rule is found in Kédang (Barnes 1974:54, 68) and is probably widespread in Indonesia. The order is also followed when erecting the second set of posts, the *kambaniru hawunjilu*, so named because they 'encircle' (*hawunjilu*) the central four, and the third, usually outermost set, the *kambaniru lambanapu*⁵ (see Fig. 1). The largest house in Rindi, the ancestral house of the noble clan, has a fourth set of posts which, being the shortest, are called *wihū wei*, 'pigs' legs'. These are then placed around the perimeter of the building, while in other houses it is the *lambanapu* posts which are thus positioned.

After the posts have been erected, the first of the large rounded beams (*patengangu*) to be put in place are the two *patengangu hoba* or *duku (hoba*, 'to place, hold in the mouth'; *duku*, 'to carry on the shoulder'), so named because of the way they fit into semi-circular indentations (*hongapu*) at the tops of the *lundungu* posts. These beams run from the front to the back of the building, and the first of the pair to be set in position is the one on the right. Afterwards, the smaller cross beams that form the base of the loft (*hindi marapu*, 'ancestral loft'), i.e., the floor of the house peak, and support the frame of the triangular tower, are put in place. The various beams are fixed in position with wooden pegs (*paku*). This part of the construction is more or less complex according to the size of the building, and there is no need to consider it in detail here. It is worth mentioning, though, that the uppermost part of the base of the peak is described as the *kadu aii hindi*. *Kadu aii*, 'hearth horns', is the name of the four planks set between the four main posts which line the hearth and thus lie directly below the loft (*hindi*); so the two structures are evidently represented as analogues located respectively in the upper and lower sections of the building. The floor of the peak consists of planks laid on top of the smaller, rounded or squared cross pieces (*wua aharu hindi*) which run parallel to the front of the building. Depending on the size of the peak, there should be four or six of these pieces, though in one case I counted five.

The Rindi designate the house peak with three names: *uma dita*, 'upper house', *kawuku uma*, 'house knot', and *tau uma*, 'body, torso of the house'. *Kawuku*, 'knot', 'joint', also refers to a knot of hair or bun,

and this, as I was told, seems to provide the closest analogy to its use in this context. As *tau*, 'body', is also 'human, person', it was once suggested that the house peak is so named because it is occupied by a 'person', namely, the clan ancestor. A more likely explanation of this use of the word, however, is found when it is compared with that whereby it refers to the globe of the sun in contrast to its rays, which are then called *wihi*, 'legs, limbs'. This indicates, therefore, that the peak is conceived as the main part of the building, whereas the lower, inhabited section is in the nature of an extension of this. The relation between the two parts is thus analogous to that which obtains between the ancestral house and the cool houses of a clan. The lower, broader section of the roof can be distinguished as the *talora uma*; *talora*, 'space between', thus refers to its intermediate position between the peak and the lower floor.

The first vertical components of the peak to be erected are the *tolaku*, two pairs of upright poles placed at the front and back to form a triangle. The lower ends are inserted in the shorter beams just either side of a space left in the base of the peak which serves as the 'mouth' (*ngaru*) or entrance to this part of the building. The vertical spars (*huku*) are then put in position, starting at the right front corner and continuing in an anti-clockwise direction around the peak. The four corner spars, like those of the lower part of the roof, are distinguished from the rest as the (*huku*) *kamundu manu*, 'chicken back (spars)', apparently by reference to the way they slope downwards, while the ones at the centre of the front and back and those of the two longer sides are called respectively the *rii ana* and *rii bai*. As noted the *ana* and *bai* are the shorter and longer sides of the house; *rii* is 'bone'. After an ancestral house is built, a piece of rotan twine is attached along the length of each of the *kamundu manu*, *rii ana*, and *rii bai*. These eight cords are then called the *kalotu rii*, or more simply, the *kalotu*, 'sinews', of the house; and it was explained that just as a man could not endure without sinew, so it is with a house. They serve no practical function. Interestingly, the 'sinews', like the 'bones', appear precisely at those positions, or points of transition, which divide and hence articulate the major horizontal sections of the house: the front and back and the two named halves of the house floor.⁶

The two (or three) outer sets of beams (*patengangu*) are then placed atop the outer series of posts proceeding from the centre. In each case, the correct order was said to be: right side, left side, front, and back, the latter pair resting atop the former. The spars that serve as the frame

of the lower part of the roof are then put in position, beginning again at the right front corner and continuing anti-clockwise, thus 'moving to the right'. Thereafter, the horizontal slats (*talaru*, also 'row, line') to which the thatch is later tied are bound to the spars. The work commences at the lowest part of the roof and proceeds upwards, an order apparently dictated by practical considerations.⁷ While I was told that when fastening the slats one should also begin at the right front corner and proceed anti-clockwise, in practice this is difficult to discern as usually large numbers of men carry out the work simultaneously on each of the four sides. On the interior side of the roof, in the middle of each of the four sides of both the peak and the lower section, are placed two horizontal rafters called *ruhu bânggi*, a term which otherwise refers to a type of sash worn around the waist (*bânggi*).

The thatching of the roof (with *alang-alang* grass, *witu*) is begun at the eaves in the centre of each of the four sides and proceeds upwards and outwards. When the old thatch is removed during renovation the reverse order is followed; but in both cases the order is determined by obvious practicalities. The rotan cords used to tie the thatch in place, however, are wound anti-clockwise (as viewed from a position facing downwards to the eaves) around the slats, thus providing another instance of 'movement to the right'. When the thatch is complete, a rectangular wooden frame is placed on the outside at the top of the peak. This is called the *kadu ai kawuku uma*, 'hearth horns of the house peak' (see *kadu ai* and *kadu ai hindi* mentioned previously), and its function is to strengthen the tower and to secure the uppermost row of thatch. In other parts of eastern Sumba, the structure is more commonly known as the *kadu uma*, 'house horns' (see Kapita 1976b: 208), a phrase which in Rindi is confined to ritual speech.⁸ A flat length of wood, the *toku ndidu* ('level stick'), is then attached to the ridge of the peak to prevent rain from seeping through the joint. Interestingly, in parallel speech *toku ndidu* is regularly conjoined with *pinu maràda*, 'surface of the plain', which refers to the top of the human head and the fontanelle. Sometimes upright pieces of wood, in which simple designs are occasionally carved, are erected at either end of the *toku ndidu*. Some houses in Rindi are provided with a strip of corrugated iron or several pieces of areca sheath (*kakomba winu*) folded over the ridge, in which case the *toku ndidu* is dispensed with.

The floor of the house is constructed after the peak is completed and the building is thatched. The four planks that line the hearth (*kadu ai*) are fitted first.⁹ Short piles (*kambaniru kaheli/bangga*) and joists

(*patengangu*) are then placed to support the floor and the verandahs (*bangga*) which run the breadth of the house at the front and back. The verandahs lie some 40 cm. lower than the interior floor. Larger houses are provided with two verandahs at the front and back, a higher one (*bangga dita*) and a lower one (*bangga wawa|handàdiku*), the latter then being situated outside the third, usually outermost, row of house posts. The number of piles varies with the size of the building, and when they are set in place, I was told, no fixed order need be observed. The planks of the floor and verandahs, each about 10 cm. in width and spaced about 2 cm. apart, are then put down. These run the breadth of the house from right to left. Along each of the two longer sides of the building are constructed two raised platforms, *nggala*, which are supported by piles perhaps 30 cm. higher than those that support the floor and extend to the edge of the verandahs at the front and back. The platform on the left side of the house is divided into sleeping compartments; another compartment is sometimes built at the right back corner. The raised areas at either end of the two verandahs, called *nggala kambàku* (because they are elevated to the height of the knee, *kambàku*, above the actual verandah), are often enclosed on three sides, the open side facing in towards the centre of the verandah or, occasionally, towards the interior of the house. These may then serve as sleeping places for guests. After the floors are completed, vertical poles (*punduku*) are inserted between the interior floor and the lowermost beams. To these are tied screens of plaited coconut leaf, gewang spines, areca sheath, or, among the very wealthy, buffalo hide, which serve as the walls (*dindingu*). The house is provided with four doors (*pindu*), one at either side at the front and back.

Between the main house post, *kambaniru uratungu*, and the *hawunjilu* post directly in front of it, is placed a partition. This is provided with a hatch, perhaps a foot square, through which food to be offered to the clan ancestor is passed during religious performances. The hatch is called the *ngaru domuru*. *Ngaru* is 'mouth'; I could not find any independent meaning of *domuru*. To the left of this partition is placed the ladder (*panongu*) of four or, when the house is so large that four would not be sufficient, eight widely spaced rungs, which provides access to the house peak.

4. Principles of Order

Names given to various parts suggest that the building may be con-

ceived to be like a human (or animal) body. The analogy is further suggested in a riddle: a man is born; he has hair; he has legs; but he has no flesh or intestines; there are only bones. The answer, of course, is a house. While it is arguable that this emphasizes as much the differences as the similarities between a man and a house, the two could yet be thought of in the same way by virtue of the close connexion between the house and the clan ancestor. It should be noted, then, that both in one or another context are described as *maii*, 'shelter, protection', i.e., as things which provide protection from physical and spiritual dangers.

A distinction that is fundamental to Rindi notions of order is that of *pingi* and *kapuka*. *Pingi* has been glossed as 'trunk', 'source', and 'origin'; it might also be translated as 'basis', 'fundament', or 'principal part'. The complementary term, *kapuka*, thus refers to the tip, top, or uppermost part of something, and has the further senses of 'derivative', 'superficial', and 'recent'. With reference to a tree or other plant, the *pingi* is, specifically, the lower portion of the trunk just above the roots,¹⁰ while the *kapuka* is the top of the tree or the tips of the branches; but the distinction is also applied in a relative way. In respect of the house, it is the basis of the rule that all vertical parts — the posts, spars, and wall supports — must be placed so that the *pingi* end of the wood points downwards. To erect a house post is *pamula*, 'to plant'. As elsewhere in eastern Indonesia (see Barnes 1974:68), therefore, this entails that the posts be put in the ground in the same way as a living tree. If the order were reversed, the Rindi say, the building would not be durable: the posts would then rot in the ground. Moreover, the well-being of the inhabitants would be threatened; thus the improper inversion of a house post, before it was corrected, was once divined to be the cause of illness and a number of deaths in a house. There are several parallel applications of this principle. For example, firewood should be placed with the *pingi* end in the fire. Though the rule seems to be followed as a matter of course, it must be observed in particular when a woman of the house is pregnant, since otherwise a breech birth would result.

The opposition of *pingi* and *kapuka* also governs the correct disposition of certain horizontal parts of the house. With regard to the beams (*patengangu*) and cross pieces (*wua aharu*) above the four main house posts, this arrangement is illustrated in Fig. 2a. If for the moment we ignore the two inner cross pieces, the disposition of *pingi* and *kapuka* may be represented as in Fig. 2b. The same order is observed in respect

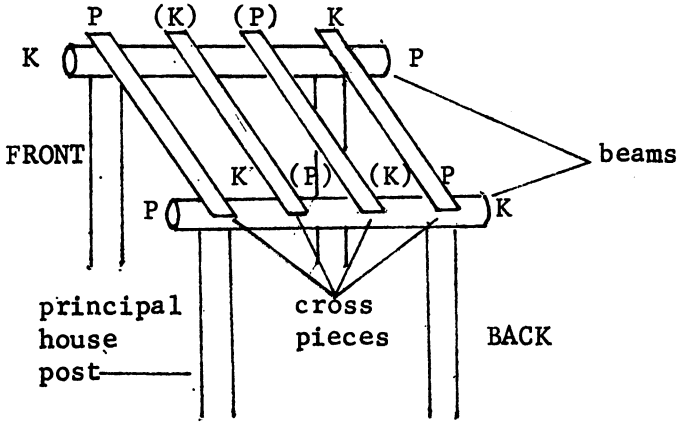

(P-pingi, K-kapuka)

FIG. 2a. Beams and Cross Pieces

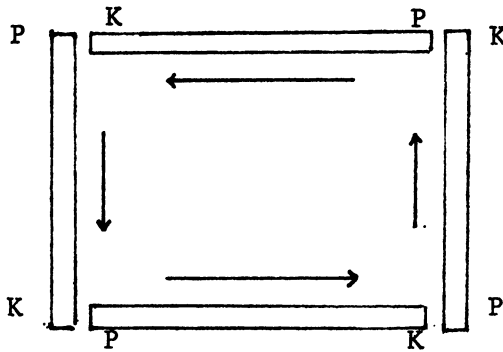

FIG. 2b. Disposition of *Pingi* and *Kapuka* in Series of Beams and Other Horizontal Components

of the beams above the outer series of posts. The operative rule, then, is that the *pingi* end of one component should meet the *kapuka* of the one placed directly above or below it. Assuming a position on the outside facing inwards towards this structure, moreover, it is evident that the *pingi* of each piece is to the left and the *kapuka* to the right. In this way, then, the arrangement articulates with another principle which I have shown to be fundamental to the sequence in which

various parts of the building are erected, namely, 'to move to the right' (*palua kawanangu*). This in fact is how the correct horizontal order was described. The required arrangement is thus represented as a conceptual, anti-clockwise movement around the building from *pingi* to *kapuka*.

The rule is further reflected in the arrangement of the bottommost rows of slats (*talaru*), where on any given side the *kapuka*, to the right, meets the *pingi* of the adjoining slat. The slat directly above, however, is arranged in the reverse manner, so that the *kapuka* is on the left. This is one instance of a further rule, which enjoins alternation (*panjilu pangiangu* or *pahilu-hilungu*) with regard to the disposition of parallel, horizontal parts. In a sense, therefore, it is only the odd rows of slats that 'proceed to the right'. Yet it was denied that the even rows conform to the opposite principle, *palua kalaingu*, 'to move to the left'; and this was rationalized in terms of the close association of this principle with death (see Chapter IX). Alternation, therefore, is a principle of order independent of that which entails movement to the right. Alternation in this case was said to be essential to the durability of the building. Since the *kapuka* end of the wood is the weaker, and so will rot more quickly than the *pingi*, to place all the *kapuka* ends of the slats at one corner would thus result in an imbalance. The same rule is observed in placing the planks of the floor and verandah (the first plank at the front edge of the floor having the *pingi* to the left), and it also applies to the various parallel pieces at the base of the house peak. The two short beams placed on top of the cross pieces (*wua aharu*), for instance, should be so disposed that the one on the right has the *pingi* at the back and the one on the left, at the front. This, then, is the inverse of the arrangement of the two larger beams that support the cross pieces; but while it thus appears to be in breach of the rule whereby the *pingi* of one component should meet the *kapuka* of the adjoining member, it does accord with the principle of alternation which governs other horizontal parts of the building.

5. Numbers

Although in some cases the feature may be partly attributable to practical requirements, the fact that many series of building components and parts of the Rindi house comprise four or eight members can be seen to express the value they attach to even numbers. In Rindi, even numbers in general were described as 'complete' (*manggànapu*) or

'fulfilling' (*matoma*), while uneven ones were said to be 'incomplete' (*mandanggànapu*) and 'insufficient' (*mandatoma*). As elsewhere in eastern Indonesia (e.g., Kédang, Barnes 1974:76), therefore, even numbers in Rindi figure generally as symbols of completeness and unity. For the most part they are also regarded as auspicious, while uneven numbers are considered inauspicious, though as I shall show in Chapter IX, a connexion can also be discerned between even totals and death.

Referring specifically to gift exchange in Mangili, Onvlee (1949:452), states that it is particularly the number eight, described as something 'that makes full' (*matoma*), which is symbolic of completeness in eastern Sumba. With regard to Rindi, this is correct insofar as totals of eight, as well as those of four and sixteen, are by far the most prominent of numerical symbols; so it is these, especially, which serve to express the values mentioned above.¹¹ Considering the pronounced dualism of Rindi thought, shown by the extensive practice of combining or dividing entities to form pairs or multiples of two, the preference for these particular totals seems to be related to the fact that they are not reducible to uneven prime numbers. It should also be noted, therefore, that two, four, eight, and sixteen are symbolically equivalent and so interchangeable in a variety of contexts in Rindi.¹² In certain instances, moreover, the requirement of even multiples of two can be seen to derive from a prescribed combination of masculine and feminine qualities, in which case the appearance of four, eight, and so on suggests an elaboration of a basic duality (see Chapter XVII). The ritual use of these numbers is further discussed in Chapter IX.¹³

Ideas regarding even and uneven totals seem also to underlie rules concerning the number of vertical spars in the roof. Thus the total number throughout the house should always be even. Although the number varies with the size of the building, I found there were always two more spars on each of the longer (*bai*) sides than on each of the shorter (*ana*) sides.¹⁴ When counting the spars on each of the four sides, moreover, in order to arrive at an even number on each side, they reckon these to include only one corner spar, which is the one on the left (facing from the outside of the building).¹⁵ Interestingly, this method of counting was described as an instance of 'movement to the right', since each corner spar can then be said to 'enter' (*tama*) the side immediately to its right. Clearly, though, since a central spar (the *rii*) is distinguished on each side of the roof, in order to calculate even totals in this way, the number of spars between any two corner spars must be

uneven; and as my records confirm, this was indeed always the case. While no direct reference was ever made to this fact — indeed, I encountered no rules expressly enjoining uneven numbers with regard to the house in Rindi — in this respect the structure of the building might therefore be compared with that found in Kédang, where ‘the solid sections between points of articulation’ are associated with uneven numbers and hence with incompleteness (Barnes 1974:76). The number of spars between any central spar and corner spar, on the other hand, can be even or uneven.

Another requirement regarding numbers is that the longer sides of the roof should be provided with more slats (*taluru*) than the shorter sides. By contrast to the rules governing the spars, however, it seems that in this regard they do not pay conscious attention to odd and even totals. While the information I received on this point was often contradictory, the common practice seems to be to place two more slats on each of the longer sides. Thus the main concern, apparently, is that the inequality of the two pairs of sides as regards their lengths should further be expressed in the vertical dimension. If the number of slats on the *ana* and *bai* sides were the same, I was told, husbands and wives and parents and children would constantly quarrel, and the householder’s first child would not live to maturity. This seems to imply, then, that to make the sides equal would be tantamount to ignoring the inequality inherent in these social relationships, thus allowing the possibility of arguments. The notion that the death of a child (*ana*) might also result from a breach of this rule also suggests an identification of the child with the extraneous slats on the shorter sides of the roof, by reference to the common designation *ana*.

With regard to the apparent absence of clearly articulated rules enjoining uneven numbers within the building, it is worth mentioning one respect in which Rindi houses contrast with those found in north coastal Sumba. When I visited this region I found that around the circumference of each of the two main house posts to the right of the hearth were carved series of eight vertical grooves or ‘paths’ (*lara*), while the two on the left each had series of seven.¹⁶ This practice is apparently related to an identification of even and uneven numbers with male and female respectively, an association which is also found, though not consistently attributed to the two sorts of numbers, in Rindi. The Rindi, however, only carve such grooves at the tops of posts; and wherever this is done, the total, as I was told, is always even.

6. Categories

Major parts and features of the house in Rindi are defined by reference to the binary contrasts of upper and lower, right and left, front and back, and inner and outer. These, as I shall show, are identically related to certain more comprehensive symbolic category pairs, and thus are represented in analogous ways. As the first term of each pair is considered superior, so far as is practically feasible those parts of the building to which these terms apply are the first to be constructed. Thus, as I have illustrated, the central peak or 'upper house' is built before the lower and outer parts of the building; and in various instances the same order is followed with regard to the horizontal distinctions of right and left and front and back.

Several pairs of complementary parts of the house are conceptually articulated by the symbolic contrast of 'female, feminine' (*kawini*) and 'male, masculine' (*mini*). With regard to the use to which different parts of the building are put, the principal analytical distinction here is that between what can be called the temporal and the spiritual, i.e., the domestic and religious or mortal and divine. It should be recalled, therefore, that ritual or religion is almost exclusively a male preserve in Rindi; hence the spiritual and temporal realms can be regarded as symbolically male and female respectively. The contrast is most clearly apparent between the upper and lower sections of the house, i.e., the peak or 'upper house' (*uma dita*) and the lower, inhabited floor (*kaheli*).¹⁷ That the former is male is suggested, first of all, by the fact that the peak is consecrated to the male ancestor of the patrilineal clan. Thus only mature men may ever enter this part of the house; all women and children are absolutely forbidden to do so. By implication, then, the entire lower part of the building is female.

As the distinction of symbolic gender governs all dimensions of the house in Rindi, however, it is further revealed in the classification of various horizontal components of the house floor. So far I have spoken of the 'big floor' (*kaheli bokulu*) and the 'cool floor' (*kaheli maringu*) as the right (*kawana*) and left (*kalai*) sections of the house. Although the Rindi do not ordinarily speak of the two sides in this way, I was told that the *kaheli bokulu* should be considered the right side; and Kapita (1976a:36) also describes it as being located on the right. Right and left, therefore, are reckoned from a position facing the exterior front of the building.¹⁸ In accordance with the general association of right with male and left with female in Rindi, the two lateral halves are

regarded as the male and female sections of the house. This is apparent from a number of particulars. First, the two central (*lundungu*) posts to the right of the hearth are described as 'male posts' (*kambaniru mini*), and those on the left as the 'female posts' (*kambaniru kawini*). This is consistent with the individual names given to these four posts (see Section 3 above). Similarly, the two sets of three hearthstones on the left side of the hearth are called the 'female hearthstones' (*tuluru kawini*), while those on the right, of which there may be one or two sets, are called the 'male hearthstones' (*tuluru mini*; see Fig. 1). Since the left, female side of the house is given over to ordinary domestic activities, this being the place where the inhabitants normally eat and sleep, only the female stones are used in the daily preparation of food. The male stones, on the other hand, have a purely ritual use, as it is here that the feathers of fowls are burnt off before removing their entrails for augury and the meat of sacrificial animals is cooked.¹⁹ Although the female hearthstones can also be said to serve a ritual purpose, since it is on these that the women cook the rice to be offered to the ancestor,²⁰ this distinction thus provides one of several instances in which what is categorically female is opposed to the spiritual or religious. Another case concerns the names given to the two water jars kept in an ancestral house. The jar that contains water for daily consumption is thus distinguished from the one which holds the water used in rites of offering, the 'ancestral jar' (*mbàlu marapu*), as the 'female jar' (*mbàlu kawini*). Since both containers are the responsibility of the women, in larger houses both are kept (on wooden blocks) in the left section of the building; the ancestral jar is then placed closer to the hearth (or, as could also be said, further in, or to the front) (see Fig. 1). But in smaller houses, where this is not practicable, the ancestral jar is situated behind the hearth on the right side, which, appropriately, is the male section of the building.

Also consistent with the symbolic masculinity of the right side of the lower part of the house is the prohibition of wives for whom bride-wealth has not been fully discharged from entering this section of an ancestral house.²¹ (As I shall show just below, this further accords with the possible characterization of this area as one of the symbolically inner parts of the house.) I was also told that when a compartment is built at the back of the right section, young women should not sleep there, though bachelors and elderly women may do so. While women are not absolutely forbidden to enter the 'big floor' (*kaheli bokulu*), therefore, as this area serves mainly a ritual purpose in the ordinary

course of affairs they have little reason to do so. Similarly, although both sexes regularly occupy the left, domestic half of the house, since most activities carried out inside the house are ones assigned to women, it is they who are more closely identified with this section. Thus, while the rules just noted need only be observed in an ancestral house, this pattern of occupation is in evidence in other buildings as well.²²

Here I might mention another usage that reveals the association of the right with spirit and divinity in Rindi. The major features of the entrails of a fowl that serve as an augury are two ribbons of flesh called the 'chicken bridge of humans' (*lindi manu maiü tau*) and the 'chicken bridge of the ancestor(s)' (*lindi manu maiü marapu*; *maiü*, which is not readily translatable here, has the sense of 'reflexion' and, perhaps, 'sign'). As the entrails are held in the palm of the hand, with the 'head' (*katiku*) towards the fingers, the former thus lies on the left side and the latter on the right.

The same sorts of distinctions as generally pertain to the right and left sides of the house are further encountered in the front and back sections of the building; thus the contrast of male and female is discernible in this dimension as well. In general, the front of the house (including the front verandah) is a formal and public area, while the back is for the most part a purely domestic place. In an ancestral house, therefore, children should not be allowed to play at the front, though they may do so at the back; and it is forbidden to bring wood, water, or burning coals through the front doors of such a building. While women are not absolutely forbidden to use the front doors, it seems relevant, then, that the provision of these items is a female responsibility.²³ Yet for the most part, the front and back of the house are more clearly distinguished in respect of their spiritual and temporal associations than with reference to male and female activities per se. Thus the women's contribution to ritual — the cooking and serving of offering rice — is discharged at the front of the left side, while the back part of the right, male section is rather more temporal than religious in character. It is clear, however, that the most consistently domestic, and hence feminine part, of the lower section of the building is the left back corner, while the right front corner is the most thoroughly religious and masculine.²⁴ It is significant, then, that the term *kaheli bokulu*, while denoting the entire right section of the house, was also said specifically to refer to the front half of this area, where the principal house post (*kambaniru uratungu*), the main focus of Rindi religious life, is located. Prohibitions that refer to the right side are thus especially in force in this quarter.

The contrasts of upper and lower, right and left, and front and back are therefore represented identically in the Rindi house. The part of the lower section of the building which is most closely connected with the 'upper house' or peak is thus the right front corner, which serves as the place for communication with the ancestor, who, in a sense, is present in the peak.²⁵ Since the veneration of the ancestor is the major function of an ancestral house, the use of such a building (and in a sense, all buildings, since these are represented as extensions of the oldest house) as a habitation may be viewed as a peripheral one. Consistent with this, then, is the observable fact that the extent to which various parts of the house are regularly or continuously occupied is inversely correlated with the extent to which they are subject to ritual restrictions, or as this could also be expressed, with the degree of their symbolic masculinity. That part of a house where people (especially the women) are most likely to be found is thus the left back corner. The peak, on the other hand, is entirely uninhabited (by mortals.)

Those sectors of the house which in one or another context can be called male, therefore, might be seen as forming together a superior, symbolically inner dimension. This applies especially to the peak, which is located in the centre of the house. Also, though the usage is not found in Rindi, it is worth noting in this regard that in western Sumba this part of the building is called the 'inner house' (*uma dana*, see Wielenga 1917:29; van Dijk 1939a:507). Since the house is inextricably associated with the patrilineal group that owns it, that the peripheral, feminine sections can accordingly be designated as the outer parts agrees with the fact that the female inhabitants either derive from other clans or are destined to leave their natal clan on marriage. Like the spiritual and the temporal, and other values identified as male and female, male and female members of the clan can therefore be distinguished as permanent and transient. It is worth noting here that when a major building which has fallen into disrepair but cannot immediately be restored is disassembled, the reusable posts and beams are stored in a shelter, called a 'wood house' (*uma ai*), which is built with the old thatch and other materials over the two rows of short piles running from front to back that supported the right side of the building. In this way, then, the entire house floor is as it were reduced to its superior male component.

It is useful at this point to mention several usages which suggest further connexions between the components of the various relations that I have suggested are conceived analogously in the Rindi house. First, to indicate relative positions towards the front or the back of the

building, the Rindi use the terms *dita*, 'up, above', and *wawa*, 'down, below' (see further Chapter III). A building located behind another is also, in this sense, 'below' it. As the house floor and the land on which it stands are for obvious reasons ideally level, the idiom cannot refer to any regular difference in elevation. Rather, I suggest, it derives from a conception of the front and back of the building as a head and a tail. Indeed, while the Rindi do not normally speak of the two parts of the house in this way, this application of *dita* and *wawa* was once explained by analogy to the human body: the front, it was said, is like a man's head while the back is like his 'tail' (*kiku*).²⁶ The idea is also consistent with the more formal names given to the back section of the house, *kiri kaheli*, 'base, foot of the floor', and *kiri ulu*, 'base of the hilt', since in ritual speech, *kiri*, 'base, foot, beginning (also 'cause')', like *kiku* ('tail'), regularly appears as the complementary term of *katiku*, 'head'. The front of the house (*hanamba*), on the other hand, is formally named the *mata yàba*; in his dictionary, Kapita (1974) gives *yàba* as 'mouth', 'opening', and 'forward part'.²⁷ These idioms thus suggest a connexion between the front and the above on the one hand and between the back and the below on the other.

In ordinary speech, the back part of the house, i.e., the back surface as well as the area just behind the building, is called the *hambeli (uma)*. Apart from 'back' or 'behind', *hambeli* also has the meaning of 'outside'; thus *lua la hambeli*, 'to go outside', is used specifically to mean 'to leave the village to defecate'.²⁸ (Indeed, because of this connotation, *hambeli* is considered a somewhat coarse way of referring to the back of the house.) As I shall later illustrate, this equation of the back and the outside is consistent with the orientation of houses in Rindi, which always face inwards towards a central village square.

It should be stressed, however, that the respectively masculine and feminine associations of inner and outer suggested above pertain specifically to the internal or ritual order of the house. Thus in another context, when the house as a whole is contrasted to all that lies outside it, the interior of the building is in most respects associated with women. The daily maintenance of the house is the recognized responsibility of its female members, and the men should avoid interfering in these matters. And for a woman habitually to stray too far from the house is considered unseemly behaviour.²⁹ This is an appropriate place to mention, then, that pigs and chickens, which are kept beneath and around the house, and the care of which is formally assigned to the women, are regarded as feminine animals in Rindi, whereas horses

and buffalo, which mostly are pastured at some distance outside the village and are tended by the men, are considered masculine animals.³⁰ It is of some significance, therefore, that horses often figure as items of exchange in formal, external dealings between clans, villages, and houses, in which women for the most part appear as passive subjects (see Chapter XVII).

I think it is clear, though, that here the distinction of inside and outside relates specifically to a temporal or domestic context; so these facts by no means contradict the characterization of the identifiably inner and outer sections of the building as male and female respectively. It is instructive in this regard to consider how male and female guests are formally received in the house. Guests in Rindi are virtually always persons related affinally to the hosts; but despite the asymmetry that generally characterizes the relation of affinity, both wife-givers and wife-takers, when they come to visit, are seated at the front of the building. This practice thus agrees with the formal and public nature of the front of the house and the informal and private nature of the back; and since the former is superior to the latter, in this way guests, regardless of alliance status, are honoured by their hosts. The male guests, however, sit on the front verandah while their female companions are received in the front part of the interior floor, usually on the left side.³¹ The men of the host group then occupy the back verandah, mainly the right side, while their women retain their usual place in the left back section of the interior. By this arrangement, therefore, men and women are principally opposed in terms of outside and inside. When on such occasions the main purpose of the visit is eventually realized, however, the arrangement changes in such a way as to reflect again the purely internal, or religious, order of the house. Thus major transactions between guests and hosts (e.g., exchanges of prestations that take place between affines at marriages and on other occasions) and subsequent rites of offering are then conducted by male speakers and priests in the right front corner of the interior while the women remain on the left side of the house.

The distinction of inner and outer (or, as it is sometimes better expressed, centre and periphery) is also of relevance to the various applications of the term 'cool' (*maringu*) in the Rindi house. Although the different senses of this term, and those of its opposite, 'hot' (*mbana*),³² will need to be discussed in a variety of contexts, for the moment it is sufficient to note that 'cool' often denotes what is free from injunction and hence generally accessible. 'Hot', then, refers to something that is

potentially dangerous and threatening and must therefore be treated with caution and respect (see Onvlee 1973:221). As noted, it is in this sense of 'cool' that the left, female side of the house is named the 'cool house floor' (*kaheli maringu*) and ordinary residential houses are called 'cool houses'. The feminine association of 'cool' is further shown by the alternative name given to the 'female water jar' (*mbàlu kawini*), namely, the 'cool jar' (*mbàlu maringu*). This, then, is another context in which *maringu* is opposed to *marapu* ('ancestral'). A parallel use of these terms is encountered in the name *hindi maringu*, 'cool loft', which refers to a rectangular shelf of bamboo or areca wood slats placed at a height of about 1.5 metres on the interior front wall, usually just to the right as one enters the right front door of the house (see Fig. 1). These are found mostly in the ancestral houses, but some cool houses have them as well. In Rindi, the main use of the rack is as a place to put the offering of betel and areca dedicated to the ancestor, thereby to make this available to him, while awaiting the preparation of the offering meal; thus the structure clearly stands in a complementary relation to the 'ancestral loft' (*hindi marapu*) in the peak of the house. It is relevant, therefore, that like other things designated as 'cool', the cool loft, in contrast to that which holds the ancestral relics, is relatively accessible and unrestricted. Indeed, another name for the *hindi maringu* is *yarangu* (or *hindi yarangu*), which is given by Kapita (1974) as 'open, exposed'. The fact that the two sorts of *hindi* are contrasted as upper and lower and inner and outer requires no further elaboration.

Those entities whose complementary opposites are designated as 'cool' must necessarily, if only in a relative sense, be 'hot'; and as I shall later illustrate, the category *marapu*, in particular, consistently includes things that the Rindi describe as 'hot'. The term *mbana* (hot), however, does not appear in names given to any parts or components of the house in Rindi. The reason for this, I suggest, may be found in the application of these same categories to the inside and outside of habitations, or to inhabited and uninhabited land (see Chapter VI). Thus, while in these latter contexts, too, the inside and the outside are distinguished in Rindi representations as masculine and feminine respectively, it is then the outside which is hot while the inside is cool.³³ This involves, moreover, a more positive sense of 'cool', namely, as conducive to life and prosperity, rather than simply free from spiritual influence; so in this frame of reference, the house as a whole, being a pre-eminently inner space providing sanctuary from harmful, external forces, is categorically cool.

In summary, therefore, we may note that the Rindi house provides several illustrations of a conceptual order founded upon the following analogically related paired categories:

male	female
above	below
right	left
front	back
inside (inner)	outside (outer)
spiritual	temporal
(hot)	cool

To these might be added the opposition of older (or elder) and younger, since as I have shown, those superior sections of the house identified with the terms in the left hand column are generally the first parts of the building to be constructed. The consistent association of the older with the spiritual and the younger with the temporal is a theme that can be discerned in many areas of Rindi ideology. The contrast of ‘trunk’ (*pingi*) and ‘tip’ (*kapuka*) provides another instance of this sort of distinction: the former is superior to the latter and, as I shall later demonstrate (see Chapter XIII), in another context the two components are distinguished as male and female respectively. While the terms do not serve to define parts of the house in the same way as, for example, right and left, it is thus worth mentioning here the expression *pingi uma*, ‘trunk, source of the house’, which refers to the senior, or oldest, line of a clan, the one most closely associated with the oldest house.³⁴ In the next chapter I shall further consider the various categories introduced above, with regard to the spatial arrangement of the village.

CHAPTER II

THE VILLAGE AND THE DOMAIN

Two topics may conveniently be discussed under this heading: (1) the types and pattern of settlement found in Rindi and (2) the internal spatial and symbolic arrangement of the village. I shall treat these in this order.

1. The Domain

The population of eastern Sumba is divided among numerous, typically small and (in former times) largely autonomous traditional domains each comprising a number of distinguishable villages and hamlets and inhabited by segments of a number of patrilineal clans. In the coastal regions, especially, the nucleus of such a political territory consists of one or more ruling clans which include members of the highest noble rank. Further towards the interior, this pattern is somewhat less in evidence, as there one often encounters small, more or less independent, clusters of villages headed only by persons of lower noble rank or by commoners. A traditional domain is therefore both a territorial association of localized descent groups and an aggregate of villages. Here I am mainly concerned with the latter aspect.

The domain is called *tana* or *paraingu*, two words which are regularly conjoined in parallel speech. While *tana*, 'earth', 'ground', 'land', 'island', and 'country', can refer to any sort of geographical entity, however, *paraingu* always denotes an inhabited area. The uninhabited part of the domain is then called 'the plain' (*maràda*). Apart from indicating the territory as a whole, *paraingu* is also used to refer specifically to the chief village of a domain. The village can further be specified as the *paraingu bokulu*, 'big, major village'.¹ This double meaning of the term is consistent with a traditional pattern of settlement found throughout eastern Sumba, in which the ancestral houses and graves of the ruling nobility and commoner clans longest established in the

domain are located in the chief village. The pattern varies from place to place, however; and in Rindi, besides the houses of the noble clan, only those of four commoner clans which hold special ritual duties were ever situated in the principal village of the domain, Parai Yawangu.² At present only the houses of the nobles remain. The majority of Rindi clans have thus always resided in subsidiary villages that surround the chief village.

As I mentioned in the Introduction, the oldest villages in Rindi are situated along the banks of the Rindi river, from the estuary to Kalihi, some 11 or 12 kilometres upstream. Parai Yawangu is centrally located about half way between these two points. In ritual language the entirety of the domain and its population is thus expressed with the phrases 'the contents of the land and the chief village, the contents of the river and the estuary' (*na ihi tana paraingu, na ihi luku mananga*), while the expression 'contents of the Rindi river' (*na ihi luku Rindi*) is used alternatively to 'the contents of the land of Rindi' (*na ihi tana Rindi*) to refer to the people of this domain.³ In this way, then, the river and the land are represented as complementary properties of the territory as a political and geographical unity. As I shall illustrate just below, the river is also of significance for the arrangement and orientation of houses and villages in Rindi.

2. *Paraingu and Kotaku*

Chief villages in eastern Sumba are typically located on elevated and relatively inaccessible sites which formerly were fortified with high stone walls and cactus hedges in order to provide a defensible position in times of strife. In Rindi, the wall that surrounded Parai Yawangu is no longer much in evidence, except in places where it forms part of corrals for horses and buffalo; and the cactus hedge just below the present main gates, which once encircled the village, is now reduced to a few scattered clusters.⁴ Since the Dutch put an end to internal warfare in the early part of this century, the *paraingu* of many eastern Sumbanese domains have gradually been abandoned in favour of lower-lying villages situated closer to fields and sources of water. In Umalulu, where only one house still stands in the former chief village, the arduous daily journey to obtain water, in particular, was often given as the reason for this dispersion. That the chief village in Rindi has remained inhabited to the present, therefore, seems to be due mainly to its relatively favourable physical location: the settlement is sited

on a low hill, little higher than the immediately surrounding landscape and just a stone's throw from the river. Even so, only eight of its former twenty or so houses are still standing, as former inhabitants have since moved elsewhere to take advantage of better agricultural land in the further reaches of the district. It should be noted, however, that apart from its former significance as a place of refuge in the event of an attack, a *paraingu* also constitutes the religious centre of a domain; and it is this aspect which accounts for the tenacity with which at least one such village has been maintained despite the practical disadvantages involved.⁵ The elevated position of the settlement in relation to other villages thus suggests another context in which the spiritual is associated with the above and the temporal with the below.

Villages subsidiary to the *paraingu* in Rindi are called *kotaku*, a term which is commonly applied to any cleared and bounded area that contains one or more permanently occupied buildings. According to the formal definition I was given, however, it properly denotes only a settlement that contains graves. This seems to suggest, then, that a site is not fully regarded as a permanent place of residence until someone has been buried there. It is also relevant here that a person should be buried in the village where the ancestral house of his clan is located, or what the Rindi describe as the 'major village' (*kotaku bokulu*); thus the formal definition of *kotaku* restricts the term to settlements which contain ancestral houses. Subsidiary villages (which thus include only cool houses), on the other hand, can be specified as 'minor villages' (*kotaku kudu*).⁶ But in accordance with the implicit equation of *kotaku* and *kotaku bokulu*, these minor settlements — or hamlets, as they might be called — are often simply referred to as *la woka*, '(dwellings) in the fields'.⁷

Woka, however, is also used in Rindi as a term complementary to *paraingu* to indicate all villages and settlements outside the chief village.⁸ This variation in the sense of the term suggests a representation of the domain as a series of concentric circles, with the *paraingu* in the centre, then the major villages, the minor villages, and finally the uninhabited 'plain' (*maràda*); so according to context *woka* can denote either both sorts of *kotaku* or the minor villages (*kotaku kudu*) alone. To some extent, this pattern accords with the physical disposition of different sorts of settlements. Thus, as noted, the chief village occupies the geographical centre of the domain, while all the major villages are situated along the river, and mostly closer to the *paraingu* than are the majority of minor villages. By virtue of this arrangement, then, the

spiritual character of a settlement as it were increases the closer one moves inwards towards the centre. Thus while the chief village and the major villages in Rindi are in a sense equivalent, as both contain ancestral houses, the former is yet considered superior in this respect to the latter. This is illustrated, for example, by the annual rites the Rindi perform to seal the boundaries of the village, in order to secure protection against intrusive forces. Although these are carried out in all major villages, the most important performance, and the one that is held first, is that which takes place in the *paraingu*, since this is considered to benefit the entire domain.⁹ Distinctions of this sort also provide a further instance of the contextual association of the outside, or the peripheral, with what is cool (or temporal) and, by implication, a connexion between the inside and what is hot (or spiritual). The *paraingu*, in particular, therefore, represents a superior inner place. Recalling also that its greater elevation places it above the rest of the domain, in these respects, then, the chief village in relation to others, is closely comparable to the peak of an ancestral house; and it is worth noting that in both, the above and the inside are spatially and symbolically conterminous (see further Chapter VI). These conceptual unities and distinctions would of course be even more pronounced in those domains where the majority of resident clans have their ancestral houses in the chief village, the lower-lying, subsidiary villages thus mostly containing only cool houses. As I shall show just below, these associations are further suggested with regard to the central and peripheral sections of the village in Rindi.

Both major and minor villages may be inhabited by members of one or more (though usually no more than two or three) clans, and in general members of a single clan are distributed over a number of villages. Except for uxori locally resident men and their families, houses are usually occupied by persons of only one clan. On the whole, Rindi villages are small. Thus of 68 named settlements in the three most densely and continuously populated *desa* (see Introduction, Section 4), in which the ancestral houses of all the Rindi clans are located, only 16 per cent had four or more buildings, while 41 per cent contained just a single house. The highest number of houses occupying a single village was eight, of which there were two cases, one being the chief village, Parai Yawangu. Besides the chief village, there were 21 other settlements that included one or more ancestral houses. About half of these had just one such house; the highest number in any settlement was five. If we consider the total number of buildings (of either sort) in these

22 villages, in just under 14 per cent of cases the ancestral house stood alone in the village, 50 per cent had a total of between two and four, and over 36 per cent had between five and eight houses. It is clear, therefore, that ancestral houses tend to be found in the larger villages. Although it is not primarily size to which the designations refer, then, 'major villages' are in general larger than 'minor villages'.

Villages and their adjacent cultivated lands are usually distinguished by name. In a few cases, however, a single name is applied to two or more small adjoining hamlets; and in other instances a village name is further used to refer to a larger area that includes several other villages, each of which has its own name. The names commonly refer to some natural or man-made feature of the landscape or the village itself.¹⁰ In most cases of this sort, the settlement is named after species of trees or other plants found growing in the vicinity. Other villages take their names from mythological associations. The hillock on which the village of Tadanu ('Whale') is located, for example, is thought to have been formed from the body of a whale left stranded after the waters of the great primeval flood (*mulungu*) subsided. The names of yet other villages refer to a group of people formerly or at present associated with the place. Indeed, this is how the name of the Rindi chief village, Parai Yawangu, is explained. According to tradition, Yawangu should actually be Wawangu, the name of an extinct clan that once lived just below the hill on which the chief village now stands (Parai is a contraction of *paraingu*). As Wawangu derives from *wawa*, 'below', the clan name was explained as referring to the location of their former village in relation to the hill.¹¹

Some uninhabited locations are named in similar ways to villages in Rindi. In ritual speech, more important villages and other locations are designated with expressions that comprise one, two, or sometimes more pairs of names. The additional epithets refer to places in the vicinity of the one principally denoted. Occasionally, the usual place names are then elaborated, in order to accord with the metrical requirements of this speech form. Parai Yawangu, for example, is thus rendered as Kambata Parai Yawangu, Kaiku Reti Pakadu. Kambata and Kaiku (a form of *kiku*) refer respectively to the upstream and downstream ends of the chief village, while Reti Pakadu ('Horned Grave') is the name of a hamlet a short distance downstream. Since the additional names employed in this type of designation often refer to uninhabited sites or simply to incidental features of the landscape, however, the practice does not reflect a regular grouping of villages into sets of two or four.

3. Spatial Order

As the *paraingu* and *kotaku* are essentially identical in respect of the arrangement of their internal parts they may be discussed together. Each village occupies a roughly level, rectangular area,¹² sometimes surrounded by a stone wall (*kilimbatu*) or wooden fence, and the houses are arranged in one or more straight rows that run parallel to the two longer sides of the village (see Fig. 3). In front of the buildings, or between the two forward rows where there is more than one, is the village square (*talora*). Although nowadays the requirement is often neglected, the square, as well as the areas between, behind, and under the houses, should at all times be kept free of grass and other vegetation. The rule reflects more than a simple liking for tidiness; rather it expresses an important aspect of Rindi classification. The general term for (unwanted) vegetation of this sort, *rumba*,¹³ in several idioms of ritual language indicates what is wild or uncontrolled. *Wei rumba*, 'wild pig', and *meu rumba*, 'wild cat', thus denote the untamed varieties of the domesticated species.¹⁴ As I shall later have occasion to show, *rumba*, moreover, connotes what is considered antithetical and threatening to social order and human well-being and thus, in a sense, what is impure and contaminating. That the village square should be kept clear of weeds thus amounts to an injunction that it be maintained as a cultural as opposed to a wild space. Also consistent with this is the idea, which I have previously mentioned, of the area of the village, like that of the house, as a cool interior encircled by a hot exterior. In this context, then, cool and hot refer in part to what is controlled and uncontrolled respectively.

When a village contains two rows of houses, they face opposite one another across the open village square; third and fourth rows are then placed behind the first two, facing in the same direction. Houses are characteristically built close together, often no more than two metres apart, so that the space between the overhanging eaves is no more than one metre. The practice, which is certainly not due to a shortage of suitable building land, can have disastrous consequences should one house catch fire. Graves, which are rectangular in shape,¹⁵ are placed in the middle of the village square in one or more lines that run parallel to the rows of houses; where there is only one row of houses, their position is often more accurately described as on the opposite side of the square.

In Rindi, the longer sides of the village, and hence the rows of

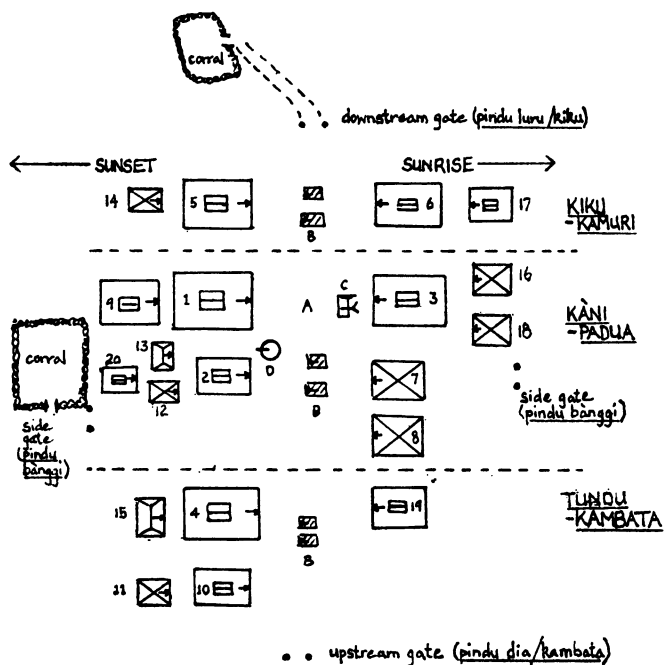

Key: (* indicates structure not standing at present)

A centre of village square
(*padua talora*)

B graves (not enumerated)

C 'skull post' (*andu katiku tau*)*

D yard altar (*katoda kawindu*)
(adjoining Uma Ndewa)

Houses (drawn approximately in proportion to size):

— of noble clan:

- | | |
|---|-----------------------|
| 1. Uma Bokulu (Haparuna) | 9. Uma Kopi |
| 2. Uma Ndewa | 10. Uma Kambata* |
| 3. Uma Andungu* | 11. Uma Tobungu* |
| 4. Uma Penji | 12. Uma Kandali* |
| 5. Uma Jangga | 13. Uma Uhu* |
| 6. Uma Wara | 14. Uma Nggunggi* |
| 7. Uma Patunggulu (now designated
Uma Andungu) | 15. Uma Malai* |
| 8. Uma Kudu | 16. Uma Katangu Kadu* |

— of commoner clans:

- | | |
|--------------------|--------------------|
| 17. Uma Karambu* | 19. Uma Tidahu* |
| 18. Uma Paterangu* | 20. Uma Luku Tana* |

 peaked house

 house without a peak

 'skull post'

 indicates direction in which
houses and graves face

FIG. 3. Sketch of the Rindi Chief Village, Parai Yawangu

houses and graves, are conceived to run parallel to the river. The two ends, or shorter sides, of the settlement, and hence the two longer sides of the houses and gravestones,¹⁶ thus face 'upstream' (*dia*) and 'downstream' (*luru*). Since the longer sides of a building are therefore perpendicular to the longer sides of the rectangular village area, and thus also to the course of the river, the disposition of the Rindi house is described as 'cutting off' or 'cutting across the river' (*kambàra luku*). In contrast, houses in more westerly parts of Sumba, the longer sides of which form the front and the back of the building, are then said to 'follow (the course of) the river' (*tundu luku*). I shall return to the question of orientation just below.

The chief village and other larger villages in Rindi each have four gates or 'doors' (*pindu*): the *pindu dia* and *pindu luru* at the upstream and downstream ends, and two *pindu bânggi*, 'waist gates', at the centre of each of the two longer sides. Smaller villages have only an upstream and a downstream gate. The gateways are not always clearly defined. Where they are, the entrance is marked on either side by a tree, commonly a *kalihi*, a sort of banyan preferred for its durability. While there is at present no means of sealing the gates, formerly thick wooden barriers were employed for this purpose, particularly in the chief village.¹⁷ The Rindi distinguish the two side or 'waist' gates as the *pindu taku wai*, 'water drawing gate', and *pindu ohu ai*, 'wood gathering gate'. Which is so designated depends simply on which side of the river the village is located; the former term refers, of course, to the one closest to the water. In Parai Yawangu, the two side gates also have further, special designations, which, however, are known only by a very few people and are rarely heard in speech. These are *pindu pangadu hili wuku*, 'the gate looking down on unmarried girls', and *pindu puru mbiliku*, which seems to mean 'the gate (from which one) descends and turns'. The latter name, since it applies to the gate on the river side, is evidently a reference to the steep descent to the water.

The upstream and downstream gates are considered the main gates of the village. They are thus sometimes described as *pindu huri*, which might be glossed as 'gates having ritual or customary significance'; and it is through these that the 'powers of reproduction and prolificity' (*paworu pabàba wàngu*) are said to enter and leave the village. But they are also regarded as the usual points of entry for harmful forces; so in order to protect the settlement a stone altar (*katoda*) is placed on the right side of each gateway (facing from inside the village). Larger villages have altars at all four entrances. The two main gates are some-

times designated as the entrance and exit (*pindu tama*, *pindu luhu*), but this is not an absolute distinction. As the main footpaths leading from one settlement to another typically connect the upstream and downstream gates of adjacent villages, in the normal course of affairs one thus enters or leaves by a given gate simply according to the direction of travel. There are, however, some contexts in which the gate by which a party should enter or leave is enjoined by rule.

As elsewhere in eastern Sumba, the upstream and downstream ends or sections of the chief village (and, on occasion, those of other villages as well) are called respectively the *kambata* and the *kiku*, or 'tail'.¹⁸ Following Kapita (1974), *kambata* is 'fragment, piece, slice' (cf. *mbata*, 'to break, broken') and 'the major part of a hill'. Although it is not normally referred to as such, on one or two occasions Rindi spoke of the *kambata* as the 'head of the village' (*katiku paraingu*). By reference to its 'head' and 'tail', therefore, the settlement can be said to be oriented towards the upstream direction. In ceremonial language, the two ends of the chief village are designated *tundu-kambata* and *kiku-kamuri*, the former terms referring to the upstream end. *Tundu* is 'hill, mound'. In the chief villages of Nàpu and Kapunduku, the upstream part of the village, as I observed, does indeed lie noticeably higher than the downstream; but in Rindi and Umalulu the sites are roughly level. Whatever the topographical facts, however, it seems nonetheless significant that the name of the upstream end of the village should indicate it to be higher, since the Rindi regard this as superior to the downstream end. *Kamuri* (or *kamudi*), referring to the downstream section or 'tail' of the village, means 'after (part)', 'what comes last', and with reference to a sailing vessel it denotes the stern (also called the 'tail').¹⁹ It was not thought in Rindi, though, that the village is like a ship, as Adams (1974:332) has claimed for another part of Sumba; and with the arguable exception of *kamuri*, the terms she adduces in support of this contention are completely general in their application. *Kambata*, moreover, is so far as I could discover applied only to a part of the village; it does not designate the prow of a vessel. Indeed, I was told that if the village is to be compared with anything in particular, it should be a man or an animal, as it has a 'head', a 'tail', a 'waist' (*bànggi*, i.e., the centre of the two longer sides, where the gates, *pindu bànggi*, are located), and a 'centre' or 'abdomen' (*padua*). The centre of the village, also designated as the *puhu* ('middle', 'navel', 'heart'), refers of course to the part between the two end sections. In ritual speech it is called the *kàni-padua* (*kàni* is also 'centre'), which phrase is sometimes further

elaborated as *rowa-padua*, *kula-kàni*. *Rowa* is 'interval, space between', while *kula* (with a long *u*) means 'hollow', 'hole'. *Padua*, the usual word for 'centre' or 'middle', derives from *dua*, 'two'; so it more exactly means 'the place at which something becomes (or is divided into) two'. Similarly, in the forms *kàningu* and *pakàningu*, *kàni* has the sense of 'to divide (out), apportion'. In some parts of eastern Sumba these sections of the chief village, and in some instances further subsections of the settlement, were formerly separated by stone walls; but there is no evidence that this was ever done in Rindi.

While the *kambata* is superior to the tail (*kiku*) of the village, these two peripheral sections are both considered subordinate to the central part. In Parai Yawangu, these distinctions are consistent with the location of the oldest, ancestral house of the noble clan in the centre of the principal row of houses, and the cool houses of the higher and lower ranking nobility in the upstream and downstream sections respectively (see Fig. 3). The house called Uma Andungu, in front of which formerly stood the post on which enemy skulls were placed (the *andu katiku tau*), and which served as the focus of war ritual, was also located in this central area, in the secondary row of houses.²⁰ (These associations are further discussed in Chapter XI.) In the subsidiary villages (*kotaku*) as well, the oldest house is generally found in the centre, later houses having been built on either side of the first. In a way analogous to the relation of the peak and the lower, inhabited part of the house, therefore, the centre of the village, in contrast to the peripheral sections, clearly represents a superior inner space associated with divinity and spirituality. As I shall later elaborate, it also seems significant in this respect that the village centre, somewhat like the peak of a house, is a relatively empty space. I refer here specifically to the very centre of the village square (*padua talora*), where one should not place graves or disturb the earth. (Other ideas that connect this spot with divinity are considered in Chapter VI.)

There is another idea which indicates that the form of the village is conceived analogously to the internal order of the house. Thus, in response to questioning, I was told that the superior *kambata* end of the village (or its 'head') was male, and the inferior 'tail' female; as noted, the same classification pertains to the front and back of a house. The side gates, the 'wood gathering gate' and the 'water drawing gate', were also said to be distinguishable as male and female respectively. It is perhaps relevant, then, that the former, lying on the land (as opposed to the river) side of the village was occasionally described as

the *pindu pangadu njara*, 'gate to watch over horses', which thus refers to a male occupation. There are, however, no complementary parts of the village in Rindi distinguished as right and left; and neither of the two sides can exclusively be regarded as 'hot' or 'cool'.

4. *A Note on Orientation*

As I have shown, houses and villages in Rindi are arranged with reference to the course of a river or stream. Especially where the river is some distance away, or otherwise out of view, however, this orientation is at best approximate; so the co-ordinates 'upstream' and 'downstream' can be seen to refer more to two segments of, rather than two points in, space. As the Rindi river and other, smaller water courses run approximately from south-west to north-east, moreover, it is therefore possible more exactly to specify the disposition of buildings, and hence villages, by reference to the sun. Indeed, this is what the Rindi say they do.

The fronts of houses which form a single line in a village, and those in the principal (or oldest) row where there are two or more rows, I was told, should face towards the rising sun (*la pahunga lodu*). As they always face opposite the principal row of houses, the graves, on the other hand, should be positioned so that the 'head' (*katiku*) or, as it is more commonly called, the 'snout' (*ngora*) of the top stone faces towards the setting sun (*la patama lodu*). (The back end of a grave stone is its 'tail', *kiku*.) The arrangement thus agrees with the more general association of the setting sun with death and the dead, and that of the rising sun with life, fertility, and prosperity, which I shall further illustrate below. Clearly, however, in large villages, the second row of houses, too, must face towards the setting sun; so in respect of the symbolic opposition of life and death their disposition might be thought to be somewhat ambiguous. It seems significant, therefore, that when I raised this point one informant denied that this row of houses confronted the setting sun, claiming instead that, as they face opposite the buildings on the other side of the village, the latter 'shut off the setting sun' (from the former). If this were not so, I was then told, the inhabitants of these houses would come to harm. In north coastal Sumba, the row of houses that faces the rising sun is called the 'afternoon (or evening) sun' (*lâdu malungu*), referring to the sun's position during the latter half of the day, while the row on the opposite side of the village is called the 'morning sun' (*lâdu mbaru*).²¹ Although the Rindi do not

employ designations of this sort — indeed they have no terms that directly refer to the two sides of the village — it is clear, therefore, that in other parts of eastern Sumba villages are oriented in the same way as in Rindi.

In most Rindi villages where I took readings, the houses faced between about 105 degrees east and 150 degrees south-east, with the greatest number between 130 and 140 degrees. Since the river runs towards the north-east, these particular orientations may simply be a function of the fact that the fronts of the buildings are placed perpendicular to the upstream and downstream gates of the village. But they are also in accordance with another rule I encountered, namely, that the houses should not directly face the rising sun or, as this was exactly expressed, that the rising sun should not 'touch' (i.e., directly confront) the bottom tip of the central spar at the front of the roof.²² It is relevant to note, then, that the position of the rising sun on Sumba varies throughout the year between about 112.5 degrees ESE and 67.5 degrees ENE. I was also told that the rising sun should not directly face the spar at the right front corner of the house, in which connexion the points at which the various beams meet in this corner of the building were mentioned. The rules thus seem to imply that the sun in its daily course should not pass through significant points of articulation and transition within the house, but should, so to speak, enter by the right front door and leave by the left back door. The position of the yard altar (*katoda kawindu*), which is usually placed just to the right and in front of the right front corner of a house (see Fig. 3), might also be significant in this respect; for one of the things the altar lends protection against is the deleterious effects of the sun's heat (see Chapter VI).

I should mention, however, that the arrangement of houses did not in all cases accord with these rules, and that the rules themselves were unknown to (or, at least, could not be articulated by) the majority of people I questioned.²³ There were even a few hamlets in Rindi where all the houses faced towards the setting rather than the rising sun; but since, with one exception, none of these contained ancestral houses, knowledgeable informants claimed that in this case it mattered little if the rules were not followed. As all these settlements were located on the north side of the river, it was also said that the buildings were actually arranged to face the footpath on the opposite side of the village from the river.²⁴ It seems significant, however, that in all instances where these villages contained graves, the fronts of the stones also faced towards the setting sun, thus in the prescribed direction. It

would appear, therefore, that the orientation of graves is of greater symbolic importance than the orientation of buildings.

In summary, it is useful to recall several general features of villages and houses in Rindi. First, settlements, like buildings, exhibit a predominance of rectangular form: the graves, the walls of the village (where these exist), internal corrals, and all parts of the house are all oblong in shape; and so are cultivated fields. Secondly, despite the apparent bilateral symmetry displayed by larger villages with houses on either side, complementary parts of the village, like those of houses and graves, are in fact governed by a conceptual asymmetry; so all paired sections are symbolically unequal. Related to this is the fact that the village, and all its component parts, are oriented both in relation to one another and by two complementary pairs of spatial co-ordinates, 'upstream' and 'downstream', and 'sunrise' and 'sunset'. Since the internal arrangement of the village can be said in a sense to consolidate these two otherwise rather approximately applied axes of orientation, it thus provides a universal model of orderly relations in space.

CHAPTER III

SPACE AND COSMOS

Having dealt with the topic of orientation with regard to the house and village, it is now useful to give a comprehensive account of the terms the Rindi employ to indicate direction and to express spatial relations in general. Since distinctions of this sort have been shown to be associated in Rindi with wider symbolic and religious values, this also provides an appropriate context in which to outline the basic features of Rindi cosmology.

To indicate direction (*mbara*), the Rindi employ six terms: *dia*, 'upstream', and *luru*, 'downstream'; *dita*, 'up, above', and *wawa*, 'down, below'; *papa*, '(on) the other side'; and *lua*, 'over', 'outside'. In speech these are usually preceded by one of the set of particles *hu*, *ni*, *na*, and *nu*. The only other word that can take these prefixes is *dalu*, 'inside', which, though it can hardly be considered a direction, will need to be mentioned as a term sometimes complementary to *lua*. *Ni*, *na*, and *nu*, which combine to form words that can be translated as 'here' or 'there', indicate relative space by reference to the spatial relation of the speaker, the person spoken to, and the object, in a way entirely unfamiliar to English.¹ While these particles have other uses, *hu*, by contrast, is only employed as a prefix to the direction words; it then refers to the general direction and not to a position relatively defined.²

The six direction terms are ubiquitous in speech. The conventional form of greeting in Rindi is the question *nggi welimu*, 'from where are you coming?' or *nggi luamu*, 'where are you going?' This requires only a perfunctory reply; and indeed the direction referred to is often obvious to the questioner. A common response is simply to answer with one of the six words given above, e.g., *weli dianggu*, 'I have come from upstream',³ though a specific place may additionally be indicated. It is clear, therefore, that the correct understanding of the principles governing the use of these various terms is of immediate concern to anyone attempting to learn the eastern Sumbanese language. The direction

words, moreover, are not confined in the manner of the English cardinal points. Thus, in a way that might at first seem curious to an outsider, *dia* (upstream) and *luru* (downstream), for example, are used to indicate relative positions and directions within the house, where we would probably use 'right' and 'left' or 'back(wards)' and 'forwards'. Usages of this sort are only possible, of course, because relatively confined spaces such as buildings and villages are oriented in terms of these directions.

1. *Papa*

For expository purposes, it is convenient to begin with *papa*. *Papa* refers to one member of a pair. The two entities, which may be concrete or abstract, can be similar or opposed; and in the latter case their relation may be one of contradiction or complementarity. The term does not therefore make what for us are fundamental logical distinctions but rather focusses on the common feature of dualism. *Papa* can thus mean both 'partner, counterpart' and 'competitor, enemy'. With regard to its further sense as 'response, reply (to a statement or presentation)', then, the derived reciprocal form *papapangu*, 'to be (in some way) opposed to one another' can have the sense of either 'to give an answer, reply' or 'to be not on speaking terms'. As I remarked earlier, the component terms of paired words or phrases in parallel language are also called *papa*.

Hapapa, 'one side' or 'the other side', is used in certain instances to count single objects grouped in pairs, e.g., earrings, armbands, and the like, or to refer to one half or side of an object or space, actually or conceptually divided into two parts.⁴ In the latter case, therefore, *papa* expresses the mutual relation of two houses facing opposite one another, the two hands, and the two sides of the body. As a direction word, usually in the form *hupapa*,⁵ it indicates a spot on the opposite side of a river, inlet, gully, path, valley, or village square. The two rows (or series of rows) of houses on either side of the village are thus mutually *hupapa*, as are the left and right sections of the house. The sort of spatial situation to which *papa* is appropriate, therefore, comprises two sides separated by an intermediate area or line which divides them absolutely. In this respect, then, it differs from left and right or an undifferentiated lateral term used as direction words,⁶ and from words that indicate direction relatively, such as 'upstream' and 'downstream'. Thus while upstream and downstream are used relatively to indicate

lateral position within the house, *papa* expresses an absolute distinction between the two (left and right) sides of the building divided by the central hearth.

Since any two positions separated by a body of water are reciprocally *papa*, *hupapa* is often used with the sense of 'abroad, across the sea'. One can also say *la hapapa tana*, literally 'on the other side of the land, earth'; and a non-Sumbanese is sometimes called *tau papa* (or *tau weli papangu*), 'person from the other side'. As places outside Sumba cannot be indicated with the other direction words, from a boat at sea, I was told, all points would be *papa*, except when it is possible to make reference to the island itself. This, as I shall show, is because the other direction terms can only be defined in relation to the land.

2. *Dia/Luru and Dita/Wawa*

Being defined solely by reference to the courses of rivers, the use of *dia* (upstream) and *luru* (downstream) as direction terms is readily understandable and so for the moment requires no further discussion. *Dita* (up, above) and *wawa* (down, below), on the other hand, are likely to provide the outsider with conceptual difficulty, which is due to the apparent variety of considerations that can determine their use. Where the other four direction words are not relevant, the Rindi use these two terms simply with reference to elevation; and though the words can refer to the slightest perceptible inclines, in this case it is usually not difficult to discover the criteria that govern their use. The outsider is likely to be confounded, however, when *dita* and *wawa* are applied to distant places, where it cannot be determined whether a difference in elevation is the deciding factor, or, indeed, where this criterion is absent or even apparently contradicted by the topographical facts. The first point that must be understood, therefore, is that the terms can refer to both what we would distinguish as vertical and horizontal extensions in space.

When I came to realize that, in some instances, *dita* and *wawa* could be used in a way roughly comparable to our cardinal directions, my initial hypothesis was that they might then refer to the rising and setting sun, *pahunga lodu* and *patama lodu*. One apparent indication that this might be so is the use of the latter terms to describe the correct disposition of houses and graves, in which context, moreover, they define an axis of orientation which is complementary to that of 'upstream' and 'downstream'. But as I was eventually able to confirm, when used as

general direction terms *dita* and *wawa* do not in fact express an orientation to the sun, or at least not directly so. Rather, they refer to a distinction which is found throughout eastern Sumba, and in the western region as well, namely, that of the 'head of the island' (*katiku tana*) and 'the tail of the island' (*kiku tana*). The expressions can indicate either the eastern and western extremities of the island respectively, or, albeit rather vaguely, its eastern and western parts.⁷

In accordance with the zoomorphic analogy which this usage suggests, the Rindi say that Sumba is shaped like an animal, specifically a horse. Thus, besides the binary distinction of head and tail, there are also the expressions *padua tana*, 'middle, abdomen of the island', which refers, of course, to the central part (the domains of Lewa, Kapunduku, and so on), and *kajia tana*, 'back of the island', which denotes the south central coast. (Apart from this use, *kajia* refers exclusively to the anatomical back in humans and animals.) The analogy finds further expression in the phrases *pakatiku njarangu*, 'horse-like head', and *pakiku tamihikungu*, 'scorpion-like tail', which describe the supposed shapes of the eastern and western extremities of the island. In Rindi, *pakatiku njarangu* was specifically identified with a large stone shaped like a horse's head, situated on the coast at Wai Jilu, in southeastern Sumba, while *pakiku tamihikungu* was said to refer in particular to the district of Kodi, in the extreme western part of the island. So far as I could discover, though, there is no mythological tradition according to which the island was created from the body of a horse. That the head of the island, in particular, should be thought to resemble that of a horse is thus probably due simply to the prominence of this animal in the traditional economy. As for the idea of a scorpion-like tail, on the other hand, it is perhaps relevant that an erect tail, such as the scorpion pre-eminently displays, is a valued feature in horses. *Pakiku tamihikungu*, however, is also the name of the tail of the constellation Scorpius. But while there is the general notion, expressed in several particulars, that features of the land are terrestrial 'reflexions' (*maü*) of certain star formations,⁸ I never encountered a constellation called the 'horse-like head' or anything similar.

As I was able to confirm after recording the directions of places relatively distant from Rindi, as one moves along the coast towards the limit of the head of the island, i.e., Wai Jilu, the direction of travel is *dita*, 'up', while if one moves towards the tail the direction is *wawa*, 'down'. The main town of Waingapu and places in central and western Sumba, therefore, are all 'down' from Rindi. For the same reason, the

western part of the island, coinciding approximately with the administrative district of West Sumba, is known in the east as Tana Wawa, 'Land Below'.⁹ Since Rindi lies close to the head of the island, only Mangili and Wai Jilu are 'up'; so as soon as one passes these territories, moving along the coast, the direction of travel again becomes 'down'. Places located further inland or closer to the coast from one's point of reference, on the other hand, are always indicated with 'upstream' and 'downstream'. Thus where orientation is possible by reference to the course of a river, this method takes precedence over the distinction of *dita* and *wawa*. Places in the interior which lie beyond the headwaters of the major eastern river systems, however, cannot be indicated in this way; so from Rindi their direction must again be expressed with reference to their proximity to the tail of the island.

In ritual, the Rindi sometimes use the terms *nunju*, 'length' and *ndàbaru*, 'width' (also 'crosswise, athwart'), to indicate respectively the eastern and western ends of Sumba, or these two general directions; and in some ceremonial contexts they expressly identify these terms with the two longer sides of the village, which as noted face roughly towards the rising and the setting sun. Since in this usage the two terms are preceded by *la*, the preposition of place, here *la ndàbaru* has the sense of 'towards the wider part', referring to the fact that as one moves westward, towards the tail of the island, the land widens. *La nunju*, on the other hand, suggests 'towards the end (proceeding lengthwise)' and thus indicates the direction of the island's eastern terminus.

Since the head and tail of Sumba generally lie towards the east and the west, the Rindi also employ *dita* and *wawa* to specify the positions of the rising and setting sun (*pahunga lodu* and *patama lodu*). Thus, they say that one goes 'up' towards the rising sun and 'down' towards the setting sun. It might be questioned, therefore, whether *dita* and *wawa* do not express an orientation to the sun after all. There are, however, several facts which suggest this is not how the Rindi see the matter. First of all, in everyday speech *pahunga lodu* and *patama lodu* are not used to express direction of travel, but only to refer to two points or segments of space. Secondly, within the village, *dita* and *wawa* are not employed to indicate positions or directions, despite the fact that houses and graves are partially oriented to the rising and setting sun. Thus the other side of a village is not 'up, above' or 'down, below', but, as I have already noted, *papa*, 'on the opposite side'. Thirdly, it should be recalled that *dita* and *wawa* cannot be used, without reference to the island, to indicate direction from a vessel at sea, whereas, conceiv-

ably, if the terms were determined by the position of the sun, they could be. Finally, Wai Jilu, which forms the extremity of the head of the island, does not in fact lie east of Rindi, but roughly SSW, so its position cannot be specified unequivocally with reference to the sun. The idea that it is located 'above', therefore, can be seen to derive instead from a particular representation of the shape and disposition of the island. A related point, then, is that *dita* and *wawa* are not the closest equivalents of English 'east' and 'west'. Indeed, when I enquired about the eastern Sumbanese equivalents of the Indonesian terms for these cardinal directions (*timur* and *barat*).¹⁰ I was not given *dita* and *wawa* but *pahunga lodu* and *patama lodu*; and these two expressions are consistently used for 'east' and 'west' in the Kambera translation of the New Testament (*Na Paràndingu Bidi*, 1961).

As I noted earlier, within the house the Rindi also employ *dita* and *wawa* to indicate position in relation to the front and back of the building. In this context, however, they clearly do not have reference to the head and tail of the island, as buildings can face in opposite directions; rather, as I previously remarked, they are expressive of ideas that govern the internal order of the house itself.¹¹ Nevertheless, recalling that the front and back of the house were also described as its head and tail, the parallel use of *dita* and *wawa* in these two contexts provides a further indication that the disposition of the house is conceived in the same way as is that of the island, which for the Sumbanese in a sense constitutes their world.

Although it might be argued that the distinction simply expresses a difference in elevation, another application of *dita* and *wawa* that should especially be noted is as a means of indicating the relative directions of the dry land (*mara*) and the sea (*tehiku*). The terms, however, do not then coincide with the distinction of 'upstream' and 'downstream', for in this context *wawa* can only be used for places located right on the coast and not ones situated merely in the direction of the sea, while *dita* refers to the land in its entirety, in opposition to the sea. From points further upriver, therefore, the estuary of a river (*mananga*, also meaning 'bay', 'inlet'), is always 'down' (*wawa*) and never 'downstream'. This accords with the Rindi conception of an estuary not as part of a river but rather as a separate place intermediate between a river and the sea. A river is also *wawa* in relation to the land; thus one always goes 'down' to the river and returns 'up' to the village.

3. *Lua*

Were it not for the grammatical resemblance between *lua* and the five other words described above, it would hardly be necessary to consider this term at all here. I do so, however, for the sake of completeness. Apart from its use in the simple sense of 'over here, there', *lua* has two other applications. In the first place, it refers to the outside of enclosed spaces such as villages, buildings, corrals, and fields, in which context it appears as the reciprocal of *dalū* (or *daa*), 'inside'. *Lua* is thus possibly cognate with Indonesian *luar*, 'outside'; I do not know whether it is also related to the verb *lua*, 'to go, move'.¹² It is important to note, however, that when used without further elaboration, the term does not unambiguously refer to what lies outside a given place. Thus, while to indicate the outside of a corral, for example, the Rindi say *hulua la hambeli oka*, the crucial word here is *hambeli*, 'outside, at the back of';¹³ *hulua la oka*, on the other hand, could simply mean 'over by the corral'. Indeed, there is no single word in eastern Sumbanese that appears as the reciprocal of *dalū*, 'inside', and thus corresponds to the English 'outside'. Instead, it is necessary in each instance to specify a particular type of exterior.

To indicate a place beyond a ridge of hills (*palindi*), the Rindi employ the expression *hulua la hambeli palindi*, which thus has the same form as that referring to the outside of a corral. Clearly, however, in this instance the reciprocal term is not *dalū* (inside); indeed, in such cases *lua* is either self-reciprocal or (with the exception of *papa*) takes one of the other direction words as its reciprocal term. The idiom just noted appears to explain why the location of the neighbouring domain of Umalulu, and several Rindi settlements situated in this direction, are referred to as *lua*, since these places lie beyond the hill ridge to the north of the Rindi river. From Umalulu, on the other hand, Rindi is always *dita* (or *hudita*), 'above', which is of course in accordance with its being located in the direction of the head of the island. By the same token, it is also possible to use *wawa* (or *huwawa*), 'below', to indicate Umalulu; but this is not usual. The reason, I suggest, is that Umalulu, as was in fact pointed out to me in this connexion, is close by. It is thus nearly as far away from the actual tail of the island as is Rindi itself, whereas from Umalulu, Rindi is sufficiently close to the head of the island to be indicated with reference to it. There are no places further away from Rindi for which *lua* is employed.

In general, therefore, *lua* can be described as a term used to express

direction or position within a fairly short distance or from a confined space where none of the five other terms is applicable or definitive.

4. *Summary Remarks on Orientation in Eastern Sumba*

As the foregoing description of the various terms has shown, the eastern Sumbanese words which seem to come closest to our notion of cardinal directions are *dita* and *wawa* and *dia* and *luru*. Unlike the four English terms, however, these two pairs of co-ordinates are defined entirely independently of one another. The first pair thus refers to the distinction of the head and tail of the island, and the second to the course of a river; so they do not form a fixed quadrant of points. In principle, therefore, the actual geometric relation of the two axes which these terms define is entirely relative to a given point of reference. They could thus be represented as two straight, intersecting lines that each rotate 180 degrees at the point of their intersection.

The eastern Sumbanese system of directions also contrasts in this respect with certain others encountered in Indonesia, in which one of two component axes refers either to the sun or the distinction of landward and seaward directions, while the other is dependent on the first. Thus on Roti, *dulu*, 'east', and *muli*, 'west', are straightforwardly defined by the positions of the rising and setting sun; 'north' and 'south' are then expressed as *ki*, 'left', and *kona*, 'right', thus assuming a position facing east (Fox 1973:356). Exactly the same method of orientation is found among the Atoni of Timor (Cunningham 1973:205-06). The words for right and left are similarly employed as direction terms in the *djaö* dialect of Ende, where they are defined in relation to the co-ordinates *riri*, 'seawards', and *reta*, 'landwards', from a position facing towards the sea (van Suchtelen 1921:239). This pattern is also encountered in West Ceram (Jensen 1947-48:38-48) and on Bali, though in the latter case the fixed direction is *kaja*, towards the interior or 'upstream' (Swellengrebel 1960:39; Covarrubias 1937:76).

The system found in eastern Sumba, therefore, more closely resembles that employed by the Ngaju of Borneo, among whom the axes of orientation — 'upriver' and 'downriver' and 'sunrise' and 'sunset' (Schärer 1963:66) — are also defined independently of one another. In this case, however, orientation is partly to the sun, whereas as I have shown, the terms that complement 'upstream' and 'downstream' in eastern Sumba refer instead to the shape of the island. In these negative respects it is also worth comparing the Rindi terms of direction with

those found in Kédang. None of the Kédang terms has reference to the sun or to the courses of rivers, nor do they define a fixed quadrant of points (see Barnes 1974:78-88). In Kédang, however, certain terms can assume the lateral opposition of left and right, whereas this is not the case in Rindi.

Unlike the other four terms, *papa*, being self-reciprocal, does not define an axis of orientation, but instead presupposes two absolutely opposed sides distinguished by reference to an actual or conceptual intermediate area or line. In practice, therefore, it complements or supplements the other four words, being used where these are not at all applicable or in conjunction with them (as, for example, when specifying a location upstream on the other side of a river). As is especially clear when *papa* is used to refer to places across the sea, the term indicates positions that conceptually lie outside of a space that can be defined in terms of 'above' and 'below' and 'upstream' and 'downstream'. The sixth word I have described above, *lua*, is even further removed from our notion of cardinal points. Indeed, not only does it have no single or fixed reciprocal term, but, by itself, it does not indicate a specific direction at all. It is thus something of a reserve term used where direction or location cannot unequivocally be specified by the other terms. However, *lua* might yet be said to express a central conception of space, i.e., one which focusses on what in some sense lies immediately outside a more or less clearly defined area occupied by the speaker.

5. *Cosmology*

The topic of cosmology is best introduced with a review of the various applications of the terms for 'head' and 'tail' (or 'base') encountered so far. There are, however, two other contexts in which this opposition is relevant that I have yet to mention. First, the two shorter ends of a (rectangular) cultivated field are distinguished respectively as the 'head of the field' (*katiku woka*) and the 'base (foot, beginning) of the field' (*kiri woka*). While Onvlee (1973:109) states that the 'head' in this case refers to the end that faces upstream, in Rindi its disposition depends on whether the longer sides of the field run parallel or perpendicular to the river; so in the latter instance the head in fact lies 'above' (*dita*), i.e., away from the river.¹⁴ The distinction is further applied to the river itself. Thus the upper course (or headwaters) is called the 'head of the river' (*katiku luku*), and the estuary the 'foot of (or 'which is') the

river mouth' (*kiri mananga*). The various spaces or objects, the components of which manifest the opposition of head and tail or base, therefore, may be listed as follows:

	'head'	'tail'	direction of 'head'
house	<i>hanamba</i>	<i>kiri ulu</i>	<i>dita</i>
grave	<i>katiku reti</i>	<i>kiku reti</i>	<i>wawa</i>
village	<i>kambata</i>	<i>kiku</i>	<i>dia</i>
island	<i>katiku tana</i>	<i>kiku tana</i>	<i>dita</i>
field	<i>katiku woka</i>	<i>kiri woka</i>	<i>dia</i> or <i>dita</i>
river	<i>katiku luku</i>	<i>kiri mananga</i>	<i>dia</i>

Several points are worth noting here. First, *kiku*, 'tail', appears as the complementary term of *katiku*, 'head', in two cases, while in another it is opposed to a special term, *kambata* (the upstream section of the village). Similarly, in two instances *katiku* is opposed to *kiri*, 'base, etc.', while in the case of the house the complementary term of *kiri* is *hanamba* ('front'). In two cases, then, what can be called a head (however it is named) is indicated with *dita*, 'above', and in another two cases with *dia*, 'upstream', while the 'head of a field' may face either *dita* or *dia* according to its particular disposition. Since in all instances the head is superior to its complement, this suggests, then, a symbolic equivalence of these two direction terms and hence, as I shall further illustrate below, a partially analogous conception of the two associated axes of orientation.¹⁵ Only in the case of graves does the superior extremity face towards an inferior (and inauspicious) direction, i.e., 'down towards the setting sun' (*huwawa la patama lodu*); but this, as I shall later show, is expressive of a deliberate symbolic inversion.

We may now introduce two categories which are of fundamental importance to Rindi thought. Thus far I have glossed the expression *katiku tana* as 'head of the island'. This of course expresses an opposition between the two ends of the island, or the earth, itself. In another context, however, the very same phrase is used with a distinct sense, as the short and more common form of the longer expression *katiku tana, katiku mata wai*, 'head of the earth, head (which is) the source of the water(s)'.¹⁶ Hereafter, I shall refer to this simply as the Head of the Earth, since, as will become clear just below, the relevant contrast here is that between the earth and the sky. In this context,

katiku tana refers not to the eastern extremity but to the interior of the island, and specifically to the region in which the major rivers have their sources. From Rindi, therefore, the Head of the Earth is located 'upstream', while the head of the island is situated 'above'.

The Head of the Earth stands in opposition to the 'base of the sky, source (or 'eye') of the sun' (*kiri awangu, mata lodu*), which I shall hereafter call simply the Base of the Sky. Phenomenally, the Rindi identify this place with the horizon, the point at which the sky meets the sea.¹⁷ Since in eastern Sumbanese, as in other Austronesian languages, *mata*, 'eye, face, etc.', also has the sense of 'source' or 'origin' (see Barnes 1977a), as the complement of *kiri awangu* the phrase *mata lodu*, although it could be simply glossed as 'sun', seems better translated as 'source of the sun'.¹⁸ This, then, identifies the Base of the Sky with the east. In ritual language, *kiri awangu, mata lodu* is sometimes further conjoined with the phrases *kuru nduu, libu muru*, 'the roaring space, the green deep', which denotes the sea. In Rindi, of course, the sea is also generally to the east. The interior of the island, on the other hand, lies roughly to the west. As will be shown below, therefore, in some contexts the Base of the Sky and the Head of the Earth are associated respectively with the rising and setting sun.

For the Rindi, however, the two categories refer not just to two areas of visible space, but to what may be described as the two opposed extremities of the universe. Their symbolic complementarity is evident from their names, which can further be glossed as 'the beginning or lowermost part of the heavens' and 'the summit or uppermost part of the earth'. Since the sky and the earth, which the Rindi expressly distinguish as male and female respectively, exhaustively compose the two halves of the world,¹⁹ the designations suggest, then, that while in one sense polar opposites, in another the two places are conceptually adjacent, and this, as I shall later demonstrate, accords with their association, in one context, with two successive stages in the cycle of being (see Chapter IX). As *katiku* (head) and *kiri* (base) are also distinguishable as male and female respectively, the names, moreover, can be seen each to comprise a masculine (viz., sky and head) and a feminine (viz., earth and base) component. On this basis, therefore, the Base of the Sky and the Head of the Earth cannot unequivocally be distinguished as male and female; and as I shall illustrate just below, this seems to accord with the diverse values with which each of the two categories is connected. In general, however, ideas concerning the Base of the Sky show it to be mainly a masculine symbol, while those concerning the

Head of the Earth indicate it to be mostly feminine. Thus while the Rindi interpret the conjoined phrases 'source of the sun' and 'base of the sky' as disguised references to the male and female genitalia respectively, as I was told, 'base of the sky' and 'head of the earth', also, can respectively connote the male and female sexual organs.²⁰ The Base of the Sky, in opposition to the Head of the Earth, moreover, is the single place of birth (and, in a sense, the present abode) of the first ancestors of the patrilineal clans.

This last association thus identifies the Base of the Sky as an important source or point of origin. But then so is the Head of the Earth, since this place is regarded as the source of the prosperity and fertility deriving from the life-giving properties of river water and rain, particularly the 'cool rain', in ritual language called 'rain that follows the (course of the) river, the cool water' (*ura tundu luku, wai maringu*), which is said to emanate exclusively from the upstream direction. Rain that comes from downstream, in contrast, is described as 'hot'. In this way, therefore, the two parts of the universe are distinguished by their respective associations with ultimate patrilineal origins and the starting point of a complementary and continuous process of renewal. The former can thus be said to express a lineal and the latter a cyclical conception of time. As I shall further have need to consider in later chapters, these distinctions also suggest a concordance with the complementary principles of patrilineal descent and asymmetric (or 'matrilateral') alliance, which form the basis of the Rindi social order.²¹

That the Base of the Sky and the Head of the Earth are significant sources is of course clearly expressed by the appearance in the names of both of these places of the term *mata*, 'source, etc.'²² In the two cases, moreover, *mata* is placed in apposition to *kiri*, 'base', (see *kiri awangu, mata lodu*) and *katiku*, 'head', (see *katiku tana, mata wai*) respectively. As previously noted, in other contexts as well *kiri* and *katiku* are associated with things designated as sources or points of origin, and *kiri*, which can further be glossed as 'beginning' or 'starting point', itself directly expresses this idea. In this context, then, the two words appear to reinforce or emphasize the sense of 'source' already present in *mata*, though since they refer to opposed spatial extremities it is further indicated that the two sources are of different kinds.²³

Another way in which the Base of the Sky and the Head of the Earth are contrasted concerns their respective associations with the sea and the sources of rivers (*mata wai*). This further involves the distinction of the estuary (*kiri mananga*) and the 'head of the river' (*katiku luku*), in

which regard the opposition of 'source of the sun' (*mata lodu*) and 'source of water (rivers)' (*mata wai*) also appears significant. Thus while the Head of the Earth represents a source of salutary coolness in Rindi, the sea is classified as 'hot' (*mbana*). In part, this pertains to their characterization of the sea as inhospitable and potentially dangerous, in which respect it is worth noting that the word for 'dry land', *mara*, has the further meaning of 'safe, secure'. In this context, however, 'hot' also refers to the ritual significance of the river estuary and the sea as the places to where physical and spiritual impurity, which they also describe as hot, are removed from the village.²⁴ Since *mbàru*, 'salty', is one of several contextually synonymous terms regularly conjoined in ritual language with *mbana*, 'hot', evidently the contrasting properties of fresh water (*wai kàba*; *kàba* is 'weak, insipid') and salt water (*wai mbàru*) are also relevant here.²⁵

The association of the Head of the Earth with coolness, and thus the Base of the Sky with what is hot, accords with the orientation of the principal end of the village, and in some cases the 'head' of a field, towards the upstream direction; the village, especially, could therefore be described as facing away from the sea. The 'head of a field', moreover, is the side through which crops receive their vital property, something which is regarded as essential not only to their own growth but to human life and reproduction as well. The custom of bringing a new bride into the village through the upstream gate, too, seems to be connected with these ideas, and provides a further indication of a link between the Head of the Earth and wife-givers.

Although they relate mainly to the sea, therefore, these associations reveal a negative aspect of the Base of the Sky. To some extent, so does its connexion with the sun, since the adverse effects of the sun's heat are something from which the Rindi regularly request divine protection. Yet, as I have indicated with regard to ideas concerning the rising sun (*pahunga lodu*), they also consider the sun as source of life. In this respect, then, we should especially recall that the Base of the Sky, or the 'source of the sun', is the place of origin of the deified first ancestors;²⁶ and indeed the sea as well is associated with the ancestors, insofar as they first journeyed to the island by sea. The Base of the Sky thus has both auspicious and inauspicious aspects. Not surprisingly, so too does the Head of the Earth, as this place is further associated in various ways with witches, forms of malevolent spirit, and death, thus with things that are regarded as 'hot'.²⁷ The main gate altar (*katoda pindu*) in a village, which serves to prevent the entry of such

harmful forces, is thus the one placed by the upstream gate.

It seems relevant in this regard that while in certain ritual contexts the Head of the Earth and the Base of the Sky in Rindi are explicitly linked with the upstream (*dia*)/downstream (*luru*) axis,²⁸ in others they are associated instead with the setting and rising sun, and hence with the terms 'below' (*wawa*) and 'above' (*dita*). Thus it is clear that both places are variously connected with a superior (viz. *dia* or *dita*) and an inferior (viz., *luru* or *wawa*) direction. What I suggest, therefore, is that in each case it is specifically the inferior direction which is linked with the inauspicious aspects, and the superior direction with the auspicious aspects, of each of these two cosmological categories.

The point can be illustrated and expanded by considering briefly the common association of both the Head of the Earth and the place of the sunset (*patama lodu*) with death. As noted, within a village, graves always face towards the setting sun, and as I shall later show, there are other usages and ideas that connect this direction with the dead. The land of the dead, however, is located in the region of the headwaters of the rivers. So while they actually leave the village by the downstream gate (see Chapter IX), the eventual destination of the souls of the deceased is said to be 'upstream' (*dia*). The compatibility of these apparently diverse representations is of course facilitated by the fact that in most parts of eastern Sumba, both the place of the sunset and the Head of the Earth (or the upstream direction) lie generally to the west and towards the interior of the island; and as I have indicated, the Rindi treat these spatial categories mostly as binary segments of space rather than as cardinal points. Even so, there is yet an apparent contradiction between the significance of the upstream direction, or the Head of the Earth, as a source of life and its association with the dead. This is resolved, however, when one takes into account the Rindi view of life and death as consecutive stages in the cycle of being, according to which what is essential to life ultimately derives from the dead (see further Chapter IX). In accordance with their association with the upstream direction, then, the dead, as life-giving spirit, are superior to the living, who in this context occupy an inferior, downstream space. Within the villages of the living, however, the houses of the dead, i.e., the graves, face in an inferior direction, namely, 'down towards the setting sun' (*huwaa la patama lodu*). It is relevant, then, that, as I shall illustrate in Chapter IX, death in Rindi is represented both as an ascent, i.e., a transition to a higher stage of being, and a descent, i.e., a termination of corporeal existence. In relation to life, therefore, death is

both a superior and an inferior state of being; and the dead have both auspicious and inauspicious aspects.

The reader might also have noticed that these ideas involve an opposition between the first ancestors (*marapu*) and the dead, who are associated with the Base of the Sky and the Head of the Earth, and the rising and setting sun, respectively. This aspect of Rindi thought is further considered in Chapter V.

Finally, I should like briefly to consider again the fact that the term *katiku tana* is applied in two distinct ways in Rindi, i.e., to designate both the Head of the Earth and the head of the island. Curiously, despite the common name the two referents in most respects appear manifestly opposed. Thus whereas the Head of the Earth is placed symbolically in conjunction with the setting sun (which is further identified with the tail of the island), the head of the island is connected with the rising sun, and hence, by implication, with the Base of the Sky. It should be recalled, however, that both the head of the island and the Head of the Earth are linked with the superior direction terms *dita* and *dia*. Thus, the former represents the superior end of the island, and insofar as it is connected with the Base of the Sky, it seems to be linked only with the auspicious aspects of this cosmological entity. It might be supposed, therefore, that in the context of their positive values, the head of the island resembles the Head of the Earth in the same way as the latter resembles the Base of the Sky. One indication of this is the identification in myth of the head of the island as a source, specifically as the place of origin, or 'trunk' (*pingi*), of the ruling, noble class. As I shall later consider, moreover, it seems partly to share this significance with the Head of the Earth.

CHAPTER IV

HAMANGU AND NDEWA

As the foregoing discussion has brought us squarely within the realm of religious thought and practice, the next three chapters are devoted solely to this topic. For analytical purposes, the various classes of spiritual beings the Rindi distinguish may be divided into two broad categories with reference to their respective associations with the sky and the earth. Chapter V, which concerns their conception of God and the important category *marapu*, therefore, is mainly concerned with the first of these, while Chapter VI is given over to the second. In the present chapter I describe several closely related concepts that pertain to what may be called soul or spirit. I begin by considering the individual soul and thereafter the notion of *ndewa*, which suggests both an aspect or attribute of the soul and a broader concept of impersonal spiritual power or divinity. These topics, as well as those treated in the two following chapters, should then provide a useful background to a description of ideas and practices relating to the life cycle (Chapters VII to IX), in which religious categories are prominently entailed.

1. *Hamangu*

The eastern Sumbanese term which seems most closely to approach our notion of 'soul' is *hamangu*, variants of which appear in many Indonesian languages (see Kruyt 1906:6-7).¹ Another form of the word, *mangu*, has the further sense of 'image, likeness'. Accordingly, I was told in Rindi that the soul has the same size and appearance as the body, but is lighter and more beautiful. It was also described as a person's 'natural, original form' (*hada memangu*). The *hamangu* is not centred in any one part of the body, though various ideas connect it, and the related concept *ndewa*, with the head, particularly the forehead, the hair, and the crown, the further associations of which I discuss in Chapter VIII.² A variant form of *mangu* is *maii*, 'shadow,

reflexion, replica'.³ But although in response to my question a friend did once identify the shadow and the soul, I am not sure whether this is a widely held idea in Rindi. Thus I never heard of any prohibitions concerning the shadow; and there is apparently nothing wrong with stepping on a person's shadow.

At death the *hamangu* leaves the body for good and eventually becomes incorporated into the land of the dead. It is thus described as the 'content' (*ihi*) of the body, which, accordingly, is said to be like a skin or membrane cast off when a person dies. As elsewhere in Indonesia, when someone is ill, severely frightened, or otherwise emotionally distressed, the soul is said to 'flee' (*palai*) or 'fly away' (*hawurungu*); so in these circumstances, but especially in cases of serious illness, the Rindi perform a ceremony in order 'to return' and 'to cool' the soul (*pabelingu hamangu, pamaringu ura hamangu*). (Here 'cool' has mainly the sense of 'to lend protection to'.) During such times the soul is said to roam outside the village,⁴ where it is in danger of being lost or seized by a witch, a consequence that might easily result in death. The soul is also thought to travel during dreams; but if it journeys too often or too far, it will not be able to return quickly to the body, and a witch might capture it. If a person dreams a great deal or has persistent or disturbing dreams, therefore, a similar rite may be held to call back the soul. It is also considered not to be good, though perhaps not particularly dangerous, to wake someone suddenly, since this can startle the soul and delay its return.

The *hamangu* is also regarded as the ultimate source of the senses and the ability to think and act. In some contexts, therefore, the word could better be translated as 'consciousness' or 'conscience' (see Wielenga 1909a:188). The Rindi thus also say that a person's soul is absent if he is careless, heedless, or generally fails to conduct himself in a proper manner. As the reciprocal offering of betel and areca is the essence of sociability and good manners in Rindi, in this connexion they describe a person's betel container as a 'sign of the soul' (*tanda hamangu*). The presence of his betel container in the house, moreover, indicates the presence there of a dead man's soul prior to the final mortuary ceremony. It is relevant here that the Rindi posit a close connexion between a person's soul and his possessions and, especially, the places he inhabits.⁵ A dead man's sleeping platform, therefore, is described as the 'most firm and secure place of his soul', the further implications of which will be shown in Chapter IX. *Hamangu* is also used to indicate a person's enthusiasm for or receptiveness to something, as

in the phrases *nda hamangunanya*, 'he has not the soul for it', and *nda na tara hamangu*, 'his soul is not strong enough'.⁶

Insofar as it concerns the individual's consciousness and personality, the concept of *hamangu* resembles that of *eti*, 'liver'. The liver is also regarded as the seat of the emotions and thought. *Eti* is thus used in a large number of phrases which refer to character traits, emotional and intellectual states, abilities, and attitudes, e.g., *nduba eti*, 'stupid (literally 'blunt') livered', i.e. stupid, dull, and *mbaha eti*, 'moist livered', i.e., happy, glad.⁷ This usage is consistent with the use of the liver of a sacrificial animal as an oracle, since the condition of the organ is believed to reflect the will and disposition of the spirit (usually the clan ancestor) to whom the animal is dedicated. Contrary to what might be expected, however, I never heard anything to suggest that the Rindi consciously identify a person's *hamangu* with his liver.⁸

In contrast to Wielenga's statement (in a note appended to Kruyt 1922:548) in which he claims *hamangu* to be exclusive to humans, the Rindi attribute it to all living things, though they clearly recognize its features to be different in humans and non-humans. Their ideas concerning the derivation of the individual soul were vague. Usually they simply say it is given by God and is present at the moment of birth; but I also encountered the idea that a child first receives his soul when he is given a name. Indeed, there is thought to be a connexion between a person's soul and that of the ancestor whose name he takes. Yet it was generally denied that his own soul and that of his namesake were one and the same. The Rindi thus evidently conceive the *hamangu* to be a personal and somewhat unique attribute of the individual.

In ritual speech, the soul is called *ura hamangu*, *lunga ranga*. It is important to note straightaway, however, that while each of the three other words has individual senses, when thus conjoined with *hamangu* they designate a single, indivisible phenomenon, though one that manifests different aspects. Accordingly, the Rindi do not speak of themselves as having four souls, or any more than one. The words *lunga* and *ranga* as a reference to the soul are encountered only in this formal idiom. *Lunga* is a string used to spin a top, and a type of locust, but neither of these senses appears to be particularly relevant here. Kapita (1974) further glosses the word as 'moisture', 'nasal mucus', and 'a cold', while for *ranga* he gives 'moisture',⁹ 'countenance, blush, (facial) glow, radiance', and, in the verbal form, *paranga*, 'to gleam, radiate'. Both words thus contain the idea of moistness, which in the case of *ranga* is related to the expression and complexion of the face.¹⁰ Possi-

bly, then, it is in this latter sense that the words are connected with the idea of soul (*hamangu*), since in Rindi, as elsewhere, a person's countenance and complexion are taken to indicate his emotions and state of mind. The idea of radiance, suggested by *ranga*, is also interesting, for the Rindi associate this quality with health, fortune, and divine or supranormal power. The widespread cosmetic and therapeutic use of coconut oil or masticated coconut flesh, which makes the body shine and also serves as a moisturizer, is evidently related to these ideas.

Ura has several senses which appear relevant to its use as the complementary term of *hamangu*. As 'sinew, nerve, vein', it indicates something which lends firmness and support; thus the phrase *atu ura*, 'having *ura* like heartwood', describes a strong, healthy person, as evidenced especially by a good, 'red' complexion. (As a modifier of *rara*, 'red', *atu* specifies a deep red colour.) Another relevant sense of *ura* is 'fate, luck, fortune'. In a number of idioms the two senses appear to be combined, as in *ura manu*, 'chicken's entrails', which are used in augury, and *ura lima, ura wihi*, 'the lines on the hands and feet', from which some people claim a person's fortune can be read.¹¹ In the phrase *atu ura*, too, good fortune as well as good health is implied, these two qualities being inseparable for the Rindi. Other uses of *ura*, however, appear to express only the idea of fate or luck, e.g., *ura dedi*, 'birth fate', meaning 'bad luck', *ura pàda*, 'misfortune' (*pàda* is 'to feel', 'to extinguish a fire', 'to wave, flutter'), and *ura tana*, 'fate of the land', which refers to the annual period of food shortage. There are also the phrases *ura meti*, 'ura of death', and *ura laku*, 'ura of departure', both of which seem to denote impending death.

Ura was once said to be like the blood of the soul (*hamangu*), an idea which may refer to *ura* in the sense of 'vein', while on another occasion it was identified with the breath. It is not clear, however, whether these are generally considered to be distinct attributes of this entity. In many contexts, moreover, *ura* and *hamangu* are used synonymously, as in *tara ura* and *tara hamangu*, both of which mean 'having a strong, enduring soul'.¹²

2. *Ndewa*

When referring to the soul in ritual language, the four words just discussed are sometimes further conjoined with the paired terms *ndewa* and *pahomba*. For the moment I shall be concerned specifically with the first of these. Although it can generally be glossed as 'spirit' or 'life

force', *ndewa*, a word ultimately of Sanskrit origin, is probably the most elusive term in the eastern Sumbanese metaphysical vocabulary. All animate things, and some we would consider inanimate as well, are said to manifest *ndewa*. In ritual idioms the word often appears in combination with either *hamangu* or *ura*; and when discussing these matters with me informants would occasionally use the phrase *ndewa hamangu* as a general reference to the soul. Despite this evidently close connexion, however, *ndewa*, unlike the three other terms that refer to the soul, is variously represented as something distinct and separable from the *hamangu*. Thus *ndewa*, often qualified as *ndewa luri* or *ndewa luri pahomba luri*, '*ndewa-pahomba* of life', is held to be immortal, whereas a person's *hamangu*, after its sojourn in the land of the dead, is thought eventually to die. Thereafter, the *ndewa*, which before was present with the *hamangu*, ascends to the sky, or to God.¹³ Interestingly, *ndewa* was once described as the 'content' of the soul. Thus it would appear that their relation is similar to that of the soul and the body. But while every person can be said to possess an individual *hamangu*, this was not thought to be the case with *ndewa*. The two concepts, therefore, might be contrasted as personal and impersonal spirit.

As 'life force', *ndewa* is also what is present in, or can be invoked at, various stone altars (*katoda*, see Chapter VI), in which context it is identified in particular with fertility and prosperity. It is thus described as the 'trunk (or source) of life' (*na pingi na luri*) and the 'all embracing trunk, the main root' (*pingi mbulungu, amu tinjangu*). Interestingly, similar expressions are applied to wife-giving affines, in reference to the possibility of life which is transferred with women from one group to another (see Chapter XIII), though I never actually heard that a person's *ndewa* derives from his wife-giver. On several occasions the *ndewa* of life (*ndewa luri*) was identified with the earliest male and female ancestors, who also are regarded as a source of life. This connexion is consistent with the notion that life derives cyclically from the dead, and while I cannot recall having heard the matter stated precisely in this way, it seems clear enough that *ndewa* is the immortal spirit which is transferred from the dead to the living. It is worth noting, then, that when the *ndewa* ascends to God after the demise of the *hamangu*, it seems the deceased loses his individuality — or by way of his name transfers it to a living descendant — and becomes as it were fused with God (see Chapter IX). Accordingly, in rites, individual food offerings are provided only for the most recently deceased members of a clan, who are often specified by name. The earlier forbears, on the other

hand, are considered to be served with the offering dedicated to the apical ancestor (*marapu*). It is important to note, however, that *ndewa* is usually spoken of as something distinct from *marapu*. One apparent reason for this is that *marapu* refers to a particular manifestation or form of spirit, whereas *ndewa* is a universal property or force. The distinction between the two thus parallels that between *ndewa* and the individual soul (*hamangu*). By the same token, *ndewa* is more clearly linked with God, who, in contrast to the apical ancestor, is similarly conceived as formless and diffuse. Thus one of the many formulaic references to God is the expression *ndewa mbulungu, pahomba mbulungu*, 'all embracing *ndewa* and *pahomba*'. Since God is said to be the ultimate source of all life, moreover, in some contexts *ndewa* might be translated as 'divinity'.¹⁴

In its other uses the term *ndewa* mostly conveys the sense of 'destiny, fate, fortune'. Thus someone blessed with good fortune is described as 'having (a) good *ndewa*', while of a person who is unable to achieve something it is said that 'his *ndewa* does not reach, his *hamangu* does not suffice' (*ndewa nda kandekalu, hamangu nda patoma*).¹⁵ In this context, then, *ndewa* especially resembles the notion of *ura*. The idea of destiny is also entailed in the use of *ndewa* to refer to certain instances of tutelary spirit. As I shall later illustrate, the latter concept can further be discerned in the association of *ndewa* with stone altars (*katoda*), since the spirits present at such places have as one of their principal functions to protect the areas over which they have dominion. Indeed, there is a more general connexion to be noted in this regard, for in Rindi thought prosperity, which is something the altar spirits also provide, is inseparably linked with the idea of fate. Hence *ndewa* could be said to encompass the two main senses of English 'fortune', i.e., 'luck' and 'prosperity' (or 'wealth'). The difference is that the Rindi treat these qualities as a type of controllable spiritual agency.

Outside the downstream gate of Parai Yawangu there is a large upright stone which is reputed to have special protective powers, and sometimes to emit an ascending green light. This was identified as the *ndewa paraingu*, a phrase that might be glossed as 'guardian of the village'. The stone, I was told, stands in a complementary relation to a large banyan (*wangga*) tree which once grew just outside the upstream gate. (Interestingly, trees of this sort are often regarded as the abodes of certain earth spirits; see Chapter VI.) At one time the villagers annually made an offering to the stone, but the rite seems now to have fallen into disuse. With regard to the concept of a personal guardian

spirit, it is useful to refer briefly to a Kambera narrative recorded by Wielenga (1913:214-20). This concerns a person's *ndewa rànja*, or, as it is more completely named in Rindi, *ndewa rànja dedi*, 'ndewa continuous with (one's) birth'.¹⁶ In the story, the spirit is expressly identified with the ancestor after whom the main character, the youngest of three children, is named, and on several occasions he saves him from the murderous designs of his jealous siblings. This spiritual protection — or 'supranormal power' (*pambiha wàngu*) as it is called in Wielenga's text — is in part bestowed upon the hero by rubbing coconut on his body 'so that he will shine like gold'. This latter detail provides one of several indications of an association between radiance (and precious metal) and spirit in eastern Sumba. In Rindi the earth spirits who inhabit the mystical domain called the *patuna* (see Chapter VI) are also reputed to be shiny;¹⁷ and at one point in the narrative recorded by Wielenga, the ancestor appears in the form of a giant, a type of being closely associated with these sorts of spirits (see Chapter VI). But this detail is difficult to reconcile with Rindi ideas, for there the dead are not identified with earth spirits. Indeed, I found the notion of *ndewa rànja* in general to be rather vague in Rindi, and all I managed to derive from direct questioning was that this is something which, rather like the *hamangu*, comes from God. However, it was also said to be given by one's ancestral namesake, and, on one occasion, to be the same as that of the forbear after whom one is named.¹⁸ As I shall explain in Chapter VIII, therefore, it seems significant that it is this ancestor, by way of conferring his name, who in a sense determines one's fate.

Another idea that identifies *ndewa* as a sort of protective power is that of *talū ndewa*. If two persons are in some way brought into conflict or competition and subsequently one suffers misfortune or illness, it is then said of the other that his *ndewa* has 'won out, proved superior' (*talū*). There is also the expression *parongu tuba ndewamu*, roughly 'to be heard by your *ndewa*', with which one swears to another that what one says is true. If it is not, then the other person's *ndewa* will exact redress.

We may now consider the term *pahomba*, with which *ndewa* is regularly conjoined in parallel speech. When used by itself in Rindi, *pahomba* nearly always denotes a sort of clan shrine located far from habitations, which consists of a forked post erected in the centre of a mound of stones. The shrine is situated in the region of the reputed original settlement of the clan ancestor, though a group which has

moved from another domain will sometimes found a second one, then distinguished as the 'replica' (*maii*) of the first, closer to its present residence. Thus the original *pahomba* of the Rindi noble clan was in Kambera, near the mouth of the Kambaniru river, while its present shrine is situated at Pataningu Manu in the Umalulu district, where the clan settled after leaving Kambera. In Rindi, however, only a few clans have a *pahomba* located in or anywhere near the domain, which appears to be due to the fact that many have settled there only recently; and in the last several decades, at any rate, the rites performed at such shrines appear to have become exclusive to the nobility.

In his dictionary, Kapita (1974) indicates the root of *pahomba* to be *homba*, 'shadow, shade, shelter', 'to cool', 'to still', and in one place he glosses the word as 'place of shade, protection'.¹⁹ He further defines *pahomba* as 'a place of a clan where the spirits of the ancestor(s) and spirits outside the village, as well as those from overseas, are paid homage', and as 'the spirits that inhabit this place'. It is far from clear, however, whether *pahomba* in this latter sense refers to anything other than what is ordinarily called just *ndewa*. Thus whenever I asked about the meaning of the term in Rindi, I was invariably told that it referred to the physical shrine. *Ndewa-pahomba*, on the other hand, was said to denote nothing other than what can be designated with *ndewa* alone. As the Rindi describe the *pahomba* shrine as the principal medium of the 'ndewa-pahomba of life' (*ndewa luri, pahomba luri*), my impression, therefore, is that *pahomba* denotes an immediate and tangible manifestation of *ndewa*, or in other words that, as in many other instances of paired terms in ritual language, *pahomba* is a metonym of *ndewa*.²⁰ This is further indicated by the use of *pahomba* in Rindi as the name of a tiny bat that habitually flies into houses at night. The species, which is thought to have supranormal powers and can assume human form, is supposed to hail from the *pahomba* shrine, whence it brings 'fecundity and prolificity, wealth and mental acumen' (*woru bàba, wulu pangàngu*). The bat is thus regarded as a good omen and it is dangerous to kill one.

In ritual language the *pahomba* shrine is called *ndewa la madita, pahomba la maràda*, 'ndewa in the high place, *pahomba* on the plain'. Since *maràda* denotes uninhabited land, the second of these phrases refers to the fact that the shrine is always located in a quiet, desolate spot well away from habitations, and near to which it is forbidden to open fields or settlements.²¹ Regarding the significance of the first component of the expression, it is relevant that in some parts of eastern

Sumba the apparently equivalent phrases are *ndewa la paraingu*, *pahomba la maràda* (Onvlee 1973:107-08); thus the Rindi idiom 'in a high place' (*la madita*) is probably an allusion to the elevated chief village (*paraingu*). As Onvlee (*ibid.*) suggests, however, the expression should not be taken to mean that *ndewa* concerns exclusively the inside of the village and *pahomba* the outside. Indeed, the general point seems to be that the two are never entirely separable in eastern Sumbanese thought. Yet it seems clear from the location of the shrine that *pahomba* specifically pertains to something — which, I suggest, is a particularly powerful manifestation or source of *ndewa* — that must be kept apart from the village. In this respect, I think, the key is to be found in the explanation I was given for the siting of the shrine far from habitations, namely that villages are where the dead are kept and buried.

The major ceremony that takes place at the *pahomba* is the *pamangu ndewa*, 'festival of the *ndewa*', when the forces of *ndewa-pahomba* are summoned to proceed to the village, where a further series of rites is held. Though it was described to me as a clan affair, in Rindi only the noble clan, which maintains a special '*ndewa* house' (the Uma Ndewa) for this purpose, seemed to have carried it out within living memory.²² Since it was last held in 1953, I have only the most fragmentary evidence concerning the ceremony itself. Being concerned with ultimate origins, however, the *pamangu ndewa* is spoken of as an undertaking of the highest importance, as it constitutes the final and paramount performance of a series of traditional rites, now largely in abeyance, which have in common the theme of replenishment and renewal.²³ Included among these are the clan's first fruits ceremony (*ngangu uhu*) and the collective *langu paraingu* festival, when the souls of the dead are summoned to the chief village (*paraingu*) to be feasted and entertained by the living. Traditionally, these rites were further co-ordinated with the major mortuary ceremonies of the noble clan and the agricultural cycle. While Onvlee (1973:105), apparently referring to eastern Sumba in general, states that the ceremony should take place once every eight years, al! I was told in Rindi regarding the time of its performance was that it should be held once every *ndalihu*, one meaning of which is 'generation', or as this was once expressed, after the birth of a great-grandson of a deceased nobleman of the highest rank. While this is unfortunately vague, the statement seems to suggest, nevertheless, that the occasion was linked with the death of a certain forbear and hence possibly concerned in particular his *ndewa* or 'immortal spirit'.

It is important to note, however, that with regard to the Rindi binary classification of rites as concerned either with life (*lii luri*) or with death (*lii meti*), *pamangu ndewa* belongs unequivocally with the former. The dissociation of *ndewa-pahomba* and death which this implies, then, is consistent with the reason given for locating the *pahomba* shrine outside the village, noted above. It is similarly held that a priest who carries out rites in the *ndewa* house of the Rindi noble clan should not officiate at funerals, and vice versa.

The various eastern Sumbanese words that might be translated as 'spirit' or 'soul' thus express a series of partially overlapping ideas that range between the notion of an individual soul and an indivisible and ubiquitous life force, which is closely linked with fate and prosperity. The principal categories, then, are *hamangu* and *ndewa*. One of the most important distinctions between these two concepts is that the *hamangu*, like the body and the several types of incorporeal or half-embodied spiritual beings I shall presently describe, is usually conceived in a particular form. *Ndewa* (or *ndewa-pahomba*), on the other hand, suggests a sort of animating principle or force that is present in or flows through forms, of which the body (or person, *tau*), the *hamangu*, and in another sense certain places and objects of ritual significance are instances. Since *ndewa* appears never to be completely identified with these,²⁴ moreover, the word thus differs from cognates in related languages (e.g., Indonesian *dewa*, 'god', 'idol') which denote clearly defined spiritual beings or deities. *Ndewa*, therefore, resembles such completely abstract notions as 'life' and 'destiny', and while it can sometimes be understood as 'divinity', or even the Divinity, I would question whether it ever refers exclusively and unambiguously to God or the ancestors.

CHAPTER V

DIVINITY AND THE ANCESTORS

1. *God*

When speaking of God I refer to a being the Rindi themselves contextually distinguish from particular manifestations of spirit regarded as intermediaries between mankind and the Divinity or as His agents. God is never addressed in rites, nor does He immediately manifest Himself in the world; and as the Rindi claim to know almost nothing about Him, very little can be obtained by direct questioning. It is useful, then, to begin by considering some of the formulaic phrases they use to refer to God.¹ Many of these are straightforwardly honorific titles, e.g., 'the most outstanding and excellent one, the greatest and the supreme' (*hupu na mangunju na marihi, hupu na mabokulu na mabai*). Most commonly, though, God is called *mawulu tau, majii tau*, 'the one who made (makes) and plaited (plaits) mankind', or *na mawulu, na majii*, 'the maker and plaiter (of everything)'. The phrases thus specifically denote a Creator God. Like other expressions applied to the Divinity, which in context are further interpreted as references to lesser spiritual beings, however, these phrases are also used to designate the clan ancestors. But while it appears that God is never distinguished absolutely from subordinate manifestations of spirit, *mawulu tau* (the short form of the expression) is usually understood to refer to a being distinct from and superior to these.

Several expressions that refer to God combine the terms *ina*, 'mother', and *ama*, 'father', e.g., *ina ukurungu, ama ukurungu*, 'the common, communal mother and father'. As I shall later show, whenever the terms are thus conjoined they denote a superior. The referents of such expressions, however, are not always connected in any way with divinity or spirituality; nor do they always clearly manifest male and female elements or aspects. In general, then, the combination of the two terms might simply be construed as an instance of the general linguistic practice of representing a unity dyadically, with elements

which manifestly or according to native interpretation are distinguishable as masculine and feminine.² In this case, however, the apparent reference to masculine and feminine qualities is consistent with an idea of God as a unity of opposed values and the unitary source of all being. This is also suggested by the commonest way of referring to God, since *wulu*, 'to make, create', 'to raise (livestock)', so far as I could determine, is applied only to male labours, while *jii*, 'to plait (e.g., baskets)', denotes an exclusively feminine activity. Though I have so far referred to God as He, this is largely an expository convenience. While some people I asked were sure He was male, others were doubtful; and I often got the impression that the question was for them a novel one. This accords with the fact that, in contrast to certain other manifestations of spirit, the Rindi seem rarely if ever to conceive of God in an embodied form.

The anonymity and obscurity of God is shown by the designations 'the one whose name is not mentioned, whose title is not uttered' (*pan-dapeku tamu, pandanyura ngara*), and 'the silent and the still, the obscure and the dark' (*na makandii makanawa, na makanjudingu makapâtangu*). The latter were also said to denote the abode of the Divinity.³ Several phrases indicate an otiose and immobile God, e.g., 'the one who has his hands on his cheeks, and folded arms' (*na manjura pipi, na maanggu luku*), which, I was told, describe a nobleman who commands but never acts.⁴ Another pair of terms with much the same import which the Rindi sometimes interpret as a reference to God is *mahanggula, mahanganji*. On its own, *mahanganji* (or *hanganji*) is the title of an elderly noble ruler who has abdicated in favour of his heir. *Mahanggula* is considered a synonym of *mahanganji* in Rindi.⁵ These phrases accord with the Rindi idea that, after creating the world, God ceased to be active and transferred responsibility for human affairs to the clan ancestors and other classes of spirits. But other expressions, which represent God as a rather more dynamic, all-knowing divinity who watches over and judges the actions of mankind, seem to contradict this image. Thus He is called 'the one who looks carefully and surveys thoroughly' (*na mailu paniningu, na mangadu katândakungu*), 'the one with big eyes and broad ears' (*na mabokulu wua matana, na mambâlaru kahiluna*), and 'the one who attends to those who transgress and err, who deviate and diverge' (*na mapatandangu manjipu manjala, na mahiliru na mahàngatu*). While no fault can be hidden from God, however, retribution is always carried out by other forces; so although God might yet retain ultimate control over the world, He

Himself does not act. Similarly, while the Rindi attribute a person's fate and the time and circumstances of his birth and death to God, they also say these things are determined by other entities, notably the individual's ancestral namesake. This I think shows that all forms of spirit tend at some point to be identified with God in Rindi. As a totality in whom are united opposed elements and qualities, therefore, He can be conceived as both dynamic and otiose (see Tobing 1956: 25-6).

Although I was told that God can be 'present' (*ningu*) in or on the earth, He is usually identified with the sky. It is somewhat surprising, then, that the Rindi do not refer to God with the names of the sun and moon, a form of designation extremely common in eastern Indonesia.⁶ But as one informant did speculate that God was like fire, the sun, and gold — all of which, it is worth noting, are things that shine — and He is occasionally linked with the sun and moon in myth, the association is probably not entirely absent from their thought. As is common elsewhere in Indonesia, the nobility, who are in other ways represented as analogous to God, moreover, are designated as the children of the sun and the moon. I might also mention here the association, which I shall later demonstrate, between various forms of spirit or divinity and precious metals: though these are said to come from the earth, they are thought ultimately to derive from the sun, the moon, and the stars.⁷

A link with divinity is rather more clearly shown in the case of the Pleiades, Antares, and the morning star. The morning star, (*kandunu marai romu*), is regarded as a bringer of prosperity and fertility. Thus what the Rindi consider to be the normal time of its rising, about an hour or so before sunrise,⁸ is the prescribed time for certain component performances of life cycle rites and the first fruits ceremony (see Chapter VIII). On the first day of the wet rice harvest a rite concerned with ensuring a good yield is held in the village at this hour, as is the final rite of the incest ceremony (see Chapter XVI). In all these cases, then, the morning star is connected with coming into being or renewal, which is apparently related to the fact that its appearance precedes and so forebodes the rising of the sun. Indeed, the star is thought once to have been another sun. The Atoni describe the morning star as the younger brother of God, whose 'most tangible manifestation' in this society is the sun (Schulte Nordholt 1971:142, 145).

Another pair of phrases that is used to refer to God is *ina pakawurungu*, *ama pakawurungu*, 'mother and father clustered together'. *Pakawurungu* derives from *kawuru*, 'cluster', the name of the Pleiades, while the shorter form of the expression, *ina pakawurungu*, can also

denote this constellation. In Rindi I recorded several versions of a myth, found elsewhere in eastern Indonesia, which concerns why the Pleiades and Antares (*tau awangu*, 'man in the sky') are located directly opposite one another in the heavens and so never appear together at night. The myth tells of a brother and sister who by inadvertently marrying committed the original act of incest. In order to separate them, the woman was banished to the place of *ina pakawurungu*, identified as the Pleiades, and her brother to Antares, 'so that they might never again look upon one another's faces'. For this reason each star does not rise until the other has set. The Pleiades thus appear just after sunset at the start of the wet season, while the evening rising of Antares marks the coming of the dry season.⁹ Although it is not entirely clear from the versions I recorded whether the couple actually became the stars, Kapitani (1976a:166), who briefly summarizes a variant of the myth, expressly states that they did. That the incestuous pair are identified with God is suggested by the fact that in one version of the myth the woman (and in another, the man and woman together) is designated as 'the one who looks carefully and surveys thoroughly' and 'the one with big eyes and broad ears'. As noted, these phrases are also applied to the Divinity. Another indication is the expression 'where the clouds sprout upwards, the Pleiades and the year sign' (*kahuluku karumangu, kawiru tanda ndaungu*),¹⁰ which denotes the abode of God. These connexions suggest then that the stars, the incestuous couple, and God are manifestations of one and the same entity.

The myth should also be considered as an explanation of the origin of incest; indeed, it was with this purpose that it was first told to me. Thus the destiny of the woman, after she is banished to the Pleiades, is described as 'to pour down indigo and lime water' (*buringu wai wora, wai kapu*), in order to confound the senses and blind the eyes, so that men and women will not recognize their 'brothers' and 'sisters'.¹¹ This is the reason people sometimes commit incest. Incest and its consequences, then, are apparently conceived as a sort of punishment, either for the original act or as a general means of divine retribution. But since the mythical woman is a manifestation of the Divinity, it also follows that incest is, in a sense, brought about by God. It should be noted here that the Rindi credit God with the creation and ultimate governance of all things, both good and bad; hence the fact that He can be implicated in something so contrary to order and propriety as incest is more easily accommodated to their view of Him than might at first appear. Another possible reason for this association, however, is that

from the original incest and its resolution derive certain distinctions essential to the coming into being of the present world. One of these is the division of the year into a wet and a dry season, the alternation of which is fundamental to Rindi notions of time. The division, which is symbolically equivalent to and entailed in the separation of the incestuous pair, is also shown to be essential to the genesis of crops. Thus one version of the myth states that the man and the woman are removed to the stars 'so that the maize may reach its early stage of growth, and the rice may make its first appearance above the ground'.¹² It is also relevant that of the three (male) children born of the incestuous union, two are placed respectively at the Head of the Earth and the *kawindu talora*, the place of the yard altar in the village (see Chapter VI), both of which are closely connected with fertility and prosperity; the third is then killed and from parts of his body spring various food crops.¹³ The places to which they are assigned, therefore, link the children and their parents with the earth and the sky respectively. Although it is not mentioned in this myth, the creation of the world is thought to have involved the masculine sky and the feminine earth coming together and then separating, an act which is thus analogous to the original incest and the subsequent separation of the protagonists, from one another and from their children. Incest thus figures in the myth as a precondition of certain distinctions fundamental to creation; so in this way its connexion with the unitary God, who is the ultimate source of these distinctions, becomes intelligible.¹⁴

2. *Marapu*

One indication of the importance of the concept of *marapu* is the Rindi practice of calling their traditional religion 'the *marapu* religion' in order to distinguish it from Christianity or Islam. The word comprises the relative pronoun *ma* and the root *rapu*. Lambooy (1937:428, 437) interprets *rapu* as a combination of *ra*, 'big, many',¹⁵ and either *apu* (actually *àpu*), 'grandmother, ancestor',¹⁶ or *pu*, a root which appears in various forms as an honorific, and as a reference to deities, throughout the Indonesian languages (see Chapter XIV, Section 5). Kapita (1976a:87), who outlines a similar etymology, explains *ra*, also, as an honorific.¹⁷ He further compares *marapu* with Manggarai *rapu*, 'corpse' (see Verheijen 1967), and Donggo *rafu*, 'soul of a dead man'.

Although in some contexts the connexion is at best indirect, when asked the Rindi will invariably identify *marapu* with the apical ancestors

of the clans. The use of the word in eastern Sumba thus differs from that encountered in the west, where it is further applied to a variety of other spiritual manifestations, the eastern equivalents of which have distinct names.¹⁸ We may begin, therefore, by considering the place of the first ancestors in Rindi religious life. In accordance with the rule of patrilineal descent, the *marapu* of a clan is usually spoken of as a single male ancestor. (The one exception to this in Rindi is the clan Kanilu, whose principal ancestral figure is a woman). The ancestor is thus addressed as 'Lord' (Umbu) and designated with a single proper name. In rites, however, a longer formulaic title which includes, besides the ancestor's usual name, several other names or descriptive epithets, thus comprising all together two or sometimes more pairs of names, is employed.¹⁹ Occasionally, when these include proper names in current use, one encounters both male and female names, which the Rindi then often explain as those of the wives, brothers, children, and other close relatives of the apical male ancestor. Since the title can thus encompass more than one generation, *marapu* can be said more generally to refer to the earliest ancestors of a clan. With certain contextual exceptions, of which I shall later provide an example, however, the term normally denotes a unitary entity.

The title of a clan's *marapu* is usually distinct from those of the ancestors of other clans. Sometimes, though, two titles include component names in common, as when two clans are reputed to derive from two full brothers, while in other instances a name interpreted as that of the father of a group of separate clan ancestors is included in their respective titles. This personage is then called the *marapu ukurungu*, 'common, communal *marapu*', a phrase which recalls the expression *ina ukurungu, ama ukurungu* as a name for God. There are also a few distinctly named clans in eastern Sumba that recognize exactly the same *marapu* ancestor, but this is uncommon.

The major axiom of eastern Sumbanese religion is that man cannot communicate directly with God. The clan ancestor, therefore, serves as an intermediary; he is the 'laid out bridge and extended crook' (*lindi papakalangu, ketu papajolangu*) which connects mankind with the Divinity. The ancestor is also a tutelary spirit. But such divine protection as he may afford can be secured only by conformity to the rules and customs instituted by the first ancestors that continue to govern the social order. Thus when death, illness, or other misfortune strikes, the Rindi commonly suppose that their clan ancestor, owing to some human transgression, or because he has not been sufficiently propiti-

ated, has revoked his protection, thus exposing them to the ravages of spiritual agencies identified with pestilence and disease. They then speak of the *pakaleha marapu*, 'rebuke of the ancestor'.²⁰ This suggests that the ancestor does not punish members of his own clan directly but rather allows retribution to be exacted by other, inherently malevolent forces. Since these are controlled by God, in a sense, then, the *marapu* protects his descendants from God's wrath. The ancestor is thus also designated as 'the shield for the hand, screen for the eyes' (*temi lima, dimba mata*), an expression which more specifically refers to the relics consecrated to the ancestor. This was explained to mean that the *marapu* screens off the hands and eyes of mortals from those of the Divinity, thus implying that God is too powerful a force to be confronted directly. While the ancestor represents mainly the positive aspect of divinity, therefore, God combines both its positive and negative aspects; so in respect of the Divinity the *marapu* provides a necessary separation as well as a connexion.

Knowledge of the first ancestors is contained in an area of mythology known as *lii ndai*, 'old lore, matters of old', or *lii marapu*, 'matters concerning the *marapu*'; the second phrase denotes both individual clan myths of origin and the history of the ancestors in general. The Rindi seem to have no single comprehensive myth that describes the creation of the world, and what I managed to record comprised various, sometimes disparate accounts of different aspects of the establishment of the present order of things. Here I shall only summarize certain general themes relevant to the topic at hand.

The *marapu* descend from an original group of beings conceived in the sky and placed on earth by God. Some accounts mention four males and four females, while according to others there were eight of each. (As noted, these two numbers are symbolically equivalent.) Another idea is that an original couple were placed at the 'liver and heart of the earth' (*eti tana, puhu tana*) — the centre of the world — whence their descendants (or a larger original group, according to the other versions) later spread to the two ends of the cosmos, the Base of the Sky and the Head of the Earth. The two groups then inter-married. The *marapu*, however, were all born at the Base of the Sky. That none were born at the Head of the Earth is attributable to the fact that, although in the context of the myth a broader conception of space is evidently implied, this place is normally identified with the interior of Sumba; and the Rindi state expressly that none of the ancestors was indigenous to the island.

As noted, the creation of the world involved the masculine sky and the feminine earth coming together, copulating, and then separating again. Thus in the beginning, I was told, the sky was so close to the earth that it was no higher than a man's height. This creative coupling of the two halves of the cosmos is apparently linked with the theme of a great primeval flood (*mulungu*) which was caused by heavy rains.²¹ In order to escape the flood, the ancestors, who were then already present on the earth, ascended to the sky, the place of God. At this time, therefore, God and the ancestors, like the sky and the earth, were not yet entirely separated from one another. But these connexions were eventually broken. After various unsuccessful attempts had been made to reclaim the earth (specifically the island of Sumba), God sent down i Mbongu i Mbaku, a being with the form of a great bird or a winged man, who is also identified with mist (*mbongu* is 'mist'; *mbaku* is a species of erne, *Haliaeetus leucogaster*), to survey the flood. In Rindi, i Mbongu i Mbaku is regarded as *marapu* by the clan Pahada (originally from Karera). When he flapped his great wings the waters receded, and to make the muddy land firm he then brought the seeds of plants and trees and different sorts of stone and soil to scatter over the earth. Once the land was dry, the ancestors descended to the Base of the Sky. God then decided further to distance Himself from them by removing with the sun and the moon to the highest heavens. With reference to the idea that the universe consists of eight levels of sky and earth (*awangu walu ndàni, tana walu ndawa*), according to one narrative I recorded this He accomplished by 'rolling up' several intervening levels of earth and sky. After this dissolution of the original unity of man (i.e., the first ancestors) and God, the *marapu* dispersed from the Base of the Sky and eventually arrived on Sumba.

The Rindi have another myth, which evidently owes a great deal to the Biblical story of the tower of Babel,²² that records how the first ancestors (who included the forbears of the Savunese, Endenese, and other neighbouring peoples, as well as the founders of the Sumbanese clans) later attempted to reunite with the Divinity. To this end they set about building a 'house of eight levels and eight layers' (*uma walu nunggulu, walu màparu*) while gathered at a place called Mbabilu, reckoned to be that part of the Base of the Sky most distant from Sumba. The house is clearly a reflexion of the cosmos, composed of eight layers of earth and sky. But God took exception to the ancestors' scheme and so conferred upon them different languages. Being unable to understand one another's speech, therefore, the building was never

finished. As is consistent with the association of even and uneven numbers with completion and incompleteness respectively, only seven levels could be erected, since each time they tried to add the eighth the attempt failed. Being unable to realize their plan, the ancestors dispersed all over the earth. Significantly, then, the dissolution of the unity of God and the ancestors also resulted in the separation of the ancestors from one another.

From the Base of the Sky the ancestors of the Sumbanese journeyed to the island by a route that includes many places whose names the Rindi identify as those of other islands in the Indonesian archipelago.²³ The phrase 'Base of the Sky', which is phenomenally identified with the horizon, also designates these places collectively. The most complete list I obtained is as follows (places to which names are thought to refer, and glosses of certain descriptive phrases, are given on the right):

- | | |
|---|--|
| 1. Uma Walu Nunggulu, Walu
Māparu | 'house of eight levels' |
| 2. Malaiya, la Hindi Wara | Malaya and India |
| 3. Kamutu Mandatoma, Lātangu
Nda Kabu | 'dike that does not suffice,
unworkable rice field' |
| 4. la Hingi Nyautu, la Kadinja
Wara | 'the seashore, the sand' |
| 5. Kuru Nduu Bokulu, Kuru Nduu
Kudu | 'great sea, small sea' |
| 6. la Kanjenga, la Bara Linggi | (?) |
| 7. la Aji, la Mbālangu | Aceh and Belawan |
| 8. Malaka, la Tana Bara | Malacca and Singapore (<i>tana bara</i>
is 'white land') |
| 9. Mahunggi, la Tana Rara | (<i>tana rara</i> is 'red land') |
| 10. Ndua Riu, la Hapa Riu | The Riau Islands |
| 11. Nggali, Palimbangu | Palembang |
| 12. Ndua Njawa, la Hapa Njawa | Java |
| 13. Jawa Bali, Jawa Muku | Bali and Lombok (?) |
| 14. Ruhuku, la Mbali | Bali |
| 15. Dopu, la Ndima (<i>or</i> Ndima, la
Makaharu, <i>or</i> la Maka, la
Ndima) | Dompou and Bima, or Bima and
Makassar ²⁴ |
| 16. Kambata Enda, la Kambata
Ndaü | Roti (i.e., the islands Eda and Ndao) |

I do not know whether it is intentional that the list includes sixteen pairs of names; but it seems symbolically most appropriate that it should. Most ancestors reached Sumba by boat, while a few descended from the sky. They landed at various places, but most notably at Cape Sasar and the mouth of the Kambaniru river, where the ancestors of most clans now resident in Rindi and neighbouring domains disembarked.

Cape Sasar, or Haharu Malai, Kataka Lindi Watu as it is known in eastern Sumba, is thought once to have been the terminus of a stone bridge (*lindi watu*) that connected Sumba with neighbouring islands.²⁵ According to Rindi myth, the bridge was destroyed by the buffalo of Umbu Pala — Umbu Lapu (*pala* is ‘to cross over’; Lapu, a common man’s name, is possibly related to *lâpahu*, ‘to pass [by]’), who brought the first of these animals to Sumba, when he drove them across. This personage is related to the founding ancestors of Ana Mburungu and several other clans in Rindi (see further Section 4 below and Chapter XII, Section 1).

Since the Base of the Sky is intermediate between the sky and the earth, the abode of God and the mortal world, the association of the *marapu* with this place is one expression of their transitional nature and their significance as intermediary spirits. In their time the first ancestors are said to have travelled freely back and forth between Sumba and the Base of the Sky. This aspect of the *marapu* also accounts for certain ambiguous and seemingly contradictory statements the Rindi make about them. The first thing to note is that they distinguish the first ancestors as *marapu* from more recent forbears, who in contrast are simply called ‘the dead’ (*mameti*).²⁶ The dead resemble the *marapu* in that both have great power over the living. Misfortune can thus be ascribed to the ‘rebuke of the dead’ (*pakaleha mameti*) as well as to that of the *marapu*; so the dead too must regularly be propitiated.²⁷ By contrast to the first ancestors, however, the dead are not represented as mediators between man and God; and as noted in Chapter III the land of the dead, located near the Head of the Earth, and the place of the *marapu* lie at opposite ends of the cosmos.

The distinction is further indicated by the notion of *kawunga mameti*, ‘the first deceased’, which refers to a descendant (or descendants) of the clan ancestor, in some cases his child, who was the first to die. There is also a general myth concerning the origin of death. Unfortunately, I was unable to obtain a complete version of it in Rindi, but the main theme is clear enough, namely, that since the earliest ancestors did not know death their numbers remained more or less static. God therefore decided that people should die, in order to initiate the cycle of life and death in which the spirit of the deceased would eventually be returned to the mortal world as renewed life. With regard to the symbolic femininity of the dead (see Chapter IX) and their connexion with the earth, it is significant that the very first person to die was a woman, and that she was buried at the Head of the Earth. Part of her name,

Rambu Harabi Raï — Raï Tana, moreover, means roughly 'to till the earth' (*raï tana*). The *marapu*, by contrast, are clearly masculine in character.

In accordance with this opposition, the Rindi claim that the first ancestors never died, but after establishing their lineages on Sumba simply returned to the Base of the Sky, where they are still present. The idea that they are immortal is of course also consistent with the representation of the *marapu* as divine beings who assisted in the creation, and the notion, fundamental to Rindi theology, of the clan ancestor as an eternally present, living spirit and an ultimate and absolute source of life. Yet, as they occupy an intermediate place in a continuous chain of being, it is evident that the first ancestors are as much connected with living mortals (and the dead) as they are with the Divinity. Thus, while the *marapu* are not classed as *tau*, 'humans, mortals', the Rindi also speak of them as normal ancestors who only later came to be regarded as *marapu* by their descendants. In addition, some of the first ancestors at least are said to have died, and in certain cases the locations of their graves are still remembered.²⁸

In this regard it is useful further to consider Rindi ideas concerning the dead. First, there is the rather curious fact that the land of the dead, while occupying the opposite end of the cosmos from the abode of the *marapu*, is nevertheless called the *parai marapu*, 'village, domain of the *marapu*'. In this context, however, the term was said not to refer to the first ancestors, but to those forbears who, by contrast to more recently deceased persons, have been completely assimilated into the afterworld. The Rindi therefore sometimes call these forbears *marapu mameti*, 'dead *marapu*' (though never just *marapu*).²⁹ The phrase reflects the idea that the souls of the dead become *marapu*,³⁰ or in other words that life and death are cyclically related. Since the dead, too, finally return to their point of origin, which is divinity, the notion that the first ancestors returned to the Base of the Sky might thus be taken as an expression of the same idea. That in one view they did not actually die, on the other hand, implies that they did not pass through this intermediate stage of existence, which agrees with the fact that the *marapu*, as I shall further illustrate in Chapter VII, represent both the beginning and the end of the cycle.

In an attempt to resolve much the same sort of apparent inconsistency among data collected elsewhere on Sumba, Lambooy (1930:282) suggests that while the eastern Sumbanese speak of the first ancestors as *marapu*, the term actually refers to something distinct from these,

which he interprets as God. In support, he cites an informant's statement that although the ancestors are now designated as *marapu*, they should actually be called *mameti beri marapu*, a phrase I would gloss as 'the dead who are equivalent to the *marapu*'. While I never heard the matter stated in quite this way in Rindi, there is some indication that they too sometimes distinguish the *marapu* as human ancestors from divine beings called by the same term, in a way that corresponds to Lambooy's formulation. Thus in the case of i Mbongu i Mbaku, who as noted is at once conceived to be a mythical bird and a clan ancestor, for example, I was told that the two manifestations refer to members of alternate generations who in accordance with present customs share the same name.³¹ Generally, though, the two are spoken of as one and the same being; and as will later become clear from the significance of personal names (see Chapter VII), the distinction in any case presupposes an essential identity; thus it is not so definitive as might at first appear. I would suggest, therefore, that Rindi ideas involve two images of the *marapu* which, owing to the transitional nature of these beings, can neither be entirely separated nor entirely reconciled. The one connects the *marapu* with God and so entails an absolute, linear view of creation, while the other pertains to the cycle of life and death as it concerns the individual.

3. *Tunggu Marapu*

Other ideas concerning the *marapu* can be derived from what the Rindi call *tunggu marapu*, 'portion of the *marapu*' or '*marapu* possessions'. There are basically three classes of *tunggu marapu*. The first are the original or oldest clan relics, sometimes distinguished as the *pingi marapu*, 'trunk of the *marapu*', which are stored in a sealed wooden chest kept in the loft inside the peak of a clan's ancestral house (*uma marapu*). These reputedly comprise golden and silver pendants, chains, and other ornaments, and sometimes metal images of the ancestral couple, boats, weapons, and the like. In ritual speech, these oldest relics, especially, are called 'the portion, possessions of his (the ancestor's) soul, the staff on which he rides' (*tunggu hamanguna, toku kalitina*). They are thus the means by which the presence of the ancestral spirit is secured and signified within the house, and they serve as a medium in rites addressed to the *marapu*, performed before the principal house post (*kambaniru uratungu*). This provides us with an important instance of the association of metal with divinity, a theme I

shall further discuss in the next chapter.³²

The second type of *tunggu marapu* consists of metal ornaments or pieces of beaten metal (*kawadaku*) that are added to the oldest relics on major ceremonial occasions. These too are kept in the peak of the house, but they are placed in a separate container — a small basket or another compartment inside a larger chest that also holds the oldest relics. The third category is rather more general, as it includes several varieties of clan heirlooms: old and valuable pendants, chains, and other ornaments used as ceremonial decoration and alliance prestations (see Chapter XVII); old spears and shields; and cooking and eating vessels, gongs, and drums used in rites that concern the ancestor. In this sense, *tunggu marapu* would also include the *marapu* horse (*njara marapu*), an especially fine stallion brought to the clan's ancestral house on important ceremonial occasions. In contrast to the two sorts of relics kept in the house peak, these items are stored in the lower section of the building. The two categories are thus distinguished as the *tunggu la hindi*, 'possessions in the loft', and *tunggu la kaheli*, 'possessions on the house floor'.³³

The three classes of *marapu* possessions are further contrasted with regard to the extent to which they are the object of prohibitions. It is strictly forbidden to view or touch the oldest relics and were anyone to do so they would become ill and most likely die. The Rindi thus describe them as extremely hot. The more recently consecrated relics are also normally out of bounds. But when first placed in the loft, they may of course be viewed and handled, albeit only by the older men; so these objects are considered somewhat less hot. The heirlooms, by contrast, may when necessary be openly viewed and handled by women as well as men. That they are not entirely cool, however, is shown by the practice of placing inside each container of old metal heirlooms one or more cheap, recently made metal pendants in order 'to cool (i.e., render safe) the valuables' (*pamaringu wangu banda*). Were this not done anyone who touched them would fall ill.

These ideas reveal a number of analogical associations illustrated in earlier chapters, viz., older : younger (more recent) :: upper part of the house : lower part :: hot : cool :: male : female. They also indicate that the older the relics the more closely associated they are with the clan ancestor, thus providing another instance of the general attribution of greater spirituality to the oldest member of a class. The Rindi similarly distinguish more recent forbears from the earliest ancestors — the first four generations (including the apical ancestor), according

to specific formulations — as cool and hot respectively. The fifth generation is thus spoken of as the *kawunga maringu*, ‘first to be cool’. In this context, however, the contrast of hot and cool appears to express an absolute rather than a relative distinction; and this corresponds to the opposition between the first ancestors (*marapu*) and more recent forbears (or the dead) shown in other areas of Rindi thought. It is significant, therefore, that they often refer to the original relics, in contrast to the other sorts of *marapu* objects, as ‘(the) *marapu*’. The implications of this designation were subject to some debate in Rindi. Thus some informants claimed that in this context the term does not actually refer to the ancestor himself, for which reason the relics should properly be called *tunggu marapu* (see Lambooy 1937:430). But this seems not to be definitive, since sometimes they use *marapu* and *tunggu marapu* to distinguish the oldest from the more recently consecrated relics.

The extent to which the Rindi identify the oldest relics with the ancestor is related to the question of whether they conceive of these as a medium between man and God, in which case they would be symbolically equivalent to the ancestor himself, or as a medium between mankind and the ancestor. Actually, both interpretations seem to be contextually valid. Put another way, the question concerns what exactly it is that is present in the peak of the ancestral house and thus identified with the metal relics. Liturgies performed in the interior right front corner of the house are typically directed to the *matimbilu halela, mahapangu halimu*, ‘the one who rises lightly and dams off with ease’, who is further addressed as ‘Lord’ (Umbu) and is requested to descend (from the house peak). In general, the phrases are understood to refer to the *marapu* as a conveyer of messages to God.³⁴ But according to another interpretation, it is not the actual ancestor, sometimes distinguished in this context as the ‘big, principal *marapu*’ (*marapu bokulu*), who is referred to here, but a subordinate spirit described as his *eri*, ‘younger (sibling), subordinate’, or *papalewa*, ‘servant’. In contrast to the ancestor, who remains at the Base of the Sky, this spirit is continually present in the house, leaving only to transfer messages to his superior.

The Rindi also address rites to ‘the one who sits at the top of the ladder, the mouth of the house peak, the one who is present at the notch and the grooves, at the flutes and the upper house’ (*na mandapu la kapuka wua panongu, la ngaru uma dita, na maninya la hongapu la payuu, la kalarangu uma dita*).³⁵ As the phrases refer to points of transition between the upper and lower parts of the building, they suggest

an association of mediating spirit with significant boundaries, a theme further developed in the next chapter. Again, by different interpretations, these expressions refer either to the *marapu* or to his spiritual subordinate. Especially in the former instance, therefore, the foundation of the peak might be compared to the Base of the Sky, as a point intermediate between the earth and the heavens, the respective places of mankind and the Divinity.

But whichever is the case, the phrases *matimbilu halela*, *hamapangu halimu* clearly denote a relatively accessible and active agent conceived in opposition to a distant and inactive manifestation of spirit. In this respect the terms *halela* and *halimu*, both of which mean 'light (of weight)', 'easy', and 'young', are significant, since the *marapu* is associated with things that are *mbotu*, 'heavy', 'difficult', 'demanding' (see Chapter VIII).³⁶ In opposition to the Divinity, however, the *marapu* is represented as an active spirit; thus the relation of *matimbilu halela* and *marapu* is formally identical to that of *marapu* and God. I suggest, therefore, that when the Rindi say that it is not actually the *marapu* but his active subordinate who is present in the house, they are in a sense thinking of the *marapu* as God. Just as the *matimbilu halela* and the *marapu* are usually not distinguished, moreover, so God and the *marapu* are so closely identified in some contexts that they appear conflated in Rindi representations; thus, as noted, phrases used to refer to God are sometimes interpreted as references to the *marapu* or other spirits subordinate to God. In this way, then, representative and represented are symbolically equated. This area of Rindi thought, I suggest, is best appreciated by considering the two members of each spiritual pair as contrasting aspects — active and inactive, mobile and immobile, accessible and inaccessible, close and distant — of an essentially unitary entity. One crucial point revealed by this analysis is that in each case it is the active member of the pair that is the inferior. Further examples of this pattern are found in the following chapter, and later I shall show how it accords with ideas concerning types of authority.

Several general observations can now be made regarding the relation between God and the first ancestors. First, it is clear that whereas inactive divinity represents unity, active divinity is connected with segmentation. The *marapu* ancestor can thus be described as a manifestation of divinity (and the Divinity) specific to a single clan, while the Rindi conception of God implies that He is the totality of the different clan ancestors. Since God is inactive in the world, moreover, for all

practical purposes He can be ignored entirely. One need only be concerned with propitiating the clan ancestor. The ancestor is thus rather more than a spiritual intermediary; he is the surrogate god of the clan.

4. *Special Attributes of Individual Marapu*

The Rindi credit each of the clan ancestors with special attributes and powers. These are described in the clan myths and sometimes form the basis of individual clan traditions. The ancestor of the clan Ana Mburungu Kalindingu, called Umbu Kalindingu (*kalindingu* is 'to float'), for example, is reputed to have travelled everywhere by sea;³⁷ hence, contrary to the usual custom, members of this clan are buried in a wooden coffin called a boat. By virtue of particular powers of their ancestors, several Rindi clans are able to provide special ritual services to others. The ancestor of the clan Ramba, for example, is claimed to have been able to cure insanity. Thus, prior to the final mortuary rite, the betel container of a deceased nobleman who was so afflicted is hung in this clan's ancestral house so that his descendants will not suffer a similar fate.

Another instance of this pattern concerns what is called *wai maringu*, 'cool water'. As I have already mentioned cooling rites and shall need to refer to them again below, it is useful to describe here in some detail what these involve. 'Cool water' refers simultaneously to the power to render cool; to consecrated water that is used for this purpose; to a deity who embodies this power — the 'cool water *marapu*' (*marapu wai maringu*), or 'the mother of raw meat, father of cool water' (*ina tolu mata, ama wai maringu*) — and to a clan, or a functionary belonging to a clan, which possesses (or 'holds', *àpa*) such a *marapu*. Only a few clans in Rindi hold or regularly exercise this power. Sometimes the cool water *marapu* and the clan's founding ancestor are one and the same, but often the figure has a distinct name and is then vaguely identified with a more recent ancestor.³⁸ The Rindi invoke the cool water *marapu* in a great variety of circumstances, too diverse to list here, whenever something considered hot and thus threatening to well-being must be dispelled, or when they feel the need to secure special divine favour and protection.

The Rindi distinguish two sorts of cool water *marapu*: the *wai maringu mánjaku*, 'calm cool water', and the *wai maringu mbana*, literally 'hot cool water'.³⁹ The former, which is the one the term *wai maringu*, when used without further specification, usually refers to, is the more

important of the pair. He neutralizes what is hot by dispensing blessing and divine favour.⁴⁰ The other type, by contrast, directly takes away the 'heat'. The two are thus generally complementary, though the *wai maringu mbana* need be invoked only when the matter at hand — incest, for example — is especially hot. Unlike the *wai maringu m̀anjaku*, this spirit is never invoked alone.

I shall briefly describe the usual procedure for invoking the *wai maringu m̀anjaku*. The principal first summons the headman of a clan that possesses such a *marapu* to his house. As is usual, the rite is held in the right front corner of the building. A priest representing the principal then presents the functionary of the *wai maringu* with one or more flakes of metal (*kaẁadaku*). How many are given depends on the number of separate matters to be communicated to the cool water *marapu*. The functionary also receives a payment, usually one metal pendant and chain, but in more serious circumstances a horse or other live animal as well. These items, presented with a portion of betel and areca, are called the *huluku pah̀apa*, 'offering and chewing ingredients', and the *tanggu hamanguna*, *toku kalitina*, the same expression as refers to ancestral relics (*tanggu marapu*). They thus serve as a medium for invoking the cool water *marapu*.⁴¹ A vessel of water in which four tiny metal chips are placed, which is to serve as the 'cool water', is then set before the functionary and the priest, who sit side by side facing the principal house post. The priest then dedicates the metal objects, together with the offering of betel and areca, usually a pig, and several fowls, to the cool water *marapu* and to the principal's own clan ancestor. One cock, preferably a black one I was told, is specifically for the cool water *marapu*. After the meal, the functionary sprinkles the cool water throughout the house and over all persons present. A description of rites involving the *wai maringu mbana* is given in Chapter XVI.

The Rindi conceive of the cool water *marapu*, specifically the *wai maringu m̀anjaku*, as an intermediary, conciliatory force separating and protecting mankind from whatever it is that is regarded as hot. They describe him as 'the sugar cane at the ridge, the banana at the boundary (or 'limit')' (*tibu la palindi*, *kaluu la padira*). 'Ridge' and 'boundary' both identify this figure as a mediator and protector, while the two plants signify coolness (see Chapter VIII). It appears, then, that the cool water *marapu* takes the place of the principal's own ancestor. As to why this should be so, it seems relevant that in many circumstances in which cooling is required — particularly transgression

and illness (which is seen as a consequence of transgression) — a clan's own *marapu* is thought likely to be offended to the extent of revoking his protection. The 'heat' of the situation, therefore, may in some measure be associated with the presumed anger of the clan ancestor. Accordingly, to invoke the cool water one must always turn to another group.

As noted just above, the cool water *marapu* is often distinguished by name from the apical ancestor of the clan which possesses it. This is also the case with other special types of *marapu* held by a few clans in Rindi. These, however, serve the purposes of the possessor alone. One sort is the *marapu raingu* (*raingu* is 'assiduous, diligent', especially with regard to agricultural labour), a figure addressed in rites that concern wet rice cultivation, performed in a house located near the fields. Others include the *marapu nggerungu* (*nggerungu*, 'to fish with a net') and the *marapu patamangu*, 'marapu of the chase', or *marapu ahu*, 'dog *marapu*', which are concerned with fishing and hunting respectively. In each case the medium of the *marapu* is a small basket containing pieces of metal, which is hung from the ceiling of a particular building. The significance of these entities seems mainly to lie in their use as special media in rites connected with specific activities, and in this respect they somewhat resemble the spirits associated with the various altars, which I shall describe in the next chapter. Nevertheless, like the principal *marapu* of a clan, they too reveal some association with human forbears. The *marapu raingu*, for example, was said to have been the first ancestor of a clan to cultivate wet rice.

Another special cult figure is the *marapu andungu*, 'skull post *marapu*', which in Rindi is possessed exclusively by the noble clan, Ana Mburungu. This is the aforementioned Umbu Pala — Umbu Lapu, a personage who is variously considered to be the father or brother of the clan's apical ancestor. The relics consecrated to this figure are kept in the clan's 'skull post house' (*uma andungu*), which, with the post itself, traditionally served as the focus of war ritual in Rindi. As noted the names of this *marapu* also form part of the complete title of the apical ancestor of Ana Mburungu, whose relics are kept in the clan's oldest house (*uma marapu*). As promised, then, this provides an example of the contextual separation of names which together denote a unitary entity, in order to distinguish special ceremonial functions.

The ancestors of some clans are especially connected with a natural species or phenomenon. The group is then said 'to treat (the thing in question) as *marapu*' (*na marapunya*), and the ancestor is spoken of as,

for example, the *marapu wuya*, 'crocodile *marapu*'. Usually, however, the ancestor and the species are not considered one and the same. Often, the connexion derives from an animal having provided the ancestor with vital assistance. Thus the ancestor of the clan Lamuru was saved from drowning by a shark when, as the result of a curse imposed by his mother's brother, his vessel capsized at sea. On reaching dry land the shark died and was given a human burial. Members of this clan, and the agnatically related clan Luku Walu, therefore, may not eat shark.

Indeed, whenever a species is considered edible a clan that regards it as *marapu* is invariably prohibited from eating it. The food is then designated as *pandangangu marapu*, 'not eaten by (or because of) the ancestor'. Not all species that are forbidden to a clan, however, are regarded in this way, though the ancestor, or a more recent forbear, often figures in the mythological rationalization of the restriction. Thus, to cite one instance, members of the clan Kanatangu will not eat eel because their ancestor was once served with a child's umbilical cord in place of eel when he arrived late at a feast; but the Kanatangu people do not speak of the eel as *marapu*. While some clans apparently have no special dietary restrictions, others have more than one. Married women continue to follow the food prohibitions of their natal clans, and these are sometimes maintained by their children; so it can happen that a group will adopt the prohibitions of a wife-giver. Married women should also observe the restrictions of their husbands' clans. Some people, however, thought that, provided no deleterious effects ensued, they were not absolutely obliged to do so. But in general I think they do avoid these foods, especially when the species in question is regarded as *marapu*.

Like the clan ancestor, certain *marapu* species serve as special clan patrons. Thus when someone is killed by a crocodile, for example, his death is seen as a punishment for an offence he or his agnates committed against a clan that regards the animal as *marapu*. A fine must then be paid to this clan, and a rite of atonement performed.⁴² Similarly, the clan Dai Ndipi has power over the *kabàla*, 'thunderbolt, lightning that strikes', which is thought to emanate from a cannon their ancestor, the *marapu kabàla*, fires upon the earth in order to punish those who transgress against his descendants. When someone is struck by lightning, therefore, Dai Ndipi can demand a heavy fine from his clan mates; a smaller fine is required when only livestock, buildings, or trees are struck. After the death, a Dai Ndipi man must 'cool' the

victim's corpse by sprinkling it with water, before it can be taken to the house for burial. The deceased's betel container and knife (which represent his soul) are then turned over to Dai Ndipi to be reclaimed once the fine is settled.

Another variation on this theme is provided by the clan Kurungu, which, because the 'grandmother' (*âpu*) of its founding ancestor turned into a monkey (*buti*), holds this animal as sacrosanct.⁴³ They may therefore neither kill nor eat monkeys. Kurungu also possesses an avenging power called *murû buti*, 'power of the monkey', which is identified with an often fatal disease manifested by convulsions and a very high fever.⁴⁴ The sufferer, I was told, shakes violently like a monkey swinging on a branch, and his teeth become exposed and chatter like a monkey's. The treatment, provided by a Kurungu man, preferably in the clan's ancestral house, consists of washing the patient with a solution of water and the leaves of a tree called *lindi buti*, 'monkey bridge'. But for this to take effect, the Kurungu *marapu* — sometimes described as the 'monkey *marapu*' (*marapu buti*) — must be invoked with a food offering; and the sufferer must give Kurungu a horse, a pendant, and a chain. If the cure succeeds, he should provide another two horses and further metal valuables. These are then reciprocated with textiles.

This procedure is one instance of what the Rindi call *paatangu wiki*, 'to subordinate oneself' (from *ata*, 'slave'), whereby a person obtains spiritual benefit by placing himself under the protection of another clan's ancestor. As the afflicted is removed, either actually or in name only, to the house of the clan (and the ancestor) concerned, the custom is also known as 'occupying one half of a house, one plank of the floor' (*umangu hapapa, kahelingu hapungu*). This further illustrates the close association between the ancestor and the house in Rindi; the occupation of a particular building is thus the means by which the link between a person or group and an ancestor is realized. In a sense, therefore, a person who thus 'subordinates himself' becomes a member of the host clan and so must observe its dietary restrictions. Moreover, as in the case of someone killed by lightning, for whom the fine has not yet been discharged, the ancestor during this time is in possession of the sufferer's soul. Should he die, therefore, his betel container and knife are retained in the host clan's ancestral house, and to reclaim them his agnates must make a payment of horses and metal valuables.

The use of *marapu* to denote a natural species or an inanimate object raises the question of whether the word always has reference to ancestors. Noting several applications of the term in eastern Sumbanese

similar to those considered above, Lambooy (1937:431-2) suggests that sometimes it does not; and if by this is meant that the thing directly referred to is unequivocally regarded as an ancestor, then clearly he is correct. From the instances just cited, and other evidence that could have been adduced, however, I have the impression that Rindi thought connects all manifestations of *marapu* in one or another way with human forbears.⁴⁵ Two other, closely related features of *marapu*, then, are that entities designated with this term are individualized — they are given individual names and accorded specific attributes — and that each is the property of a particular lineal descent group. The concept is thus an aspect of the social order; and as I shall demonstrate just below, in these respects the *marapu* differ from the other classes of intermediary spirit the Rindi distinguish.

CHAPTER VI

THE POWERS OF THE EARTH

Rindi ideas show the *marapu* to be associated with the house, particularly the upper section of the building, and with the sky as opposed to the earth. The present chapter is concerned with another side of Rindi religion, which relates to the earth and spiritual forces identified with places outside the house and village. The two classes of spirit, therefore, can be distinguished with regard to, *inter alia*, the oppositions of above and below, inside and outside, and, as I shall further demonstrate below, masculine and feminine.

The earth occupies a rather ambiguous place in Rindi thought. On the one hand, they address it reverentially as 'earth that is the most exalted mother and father' (*tana mamaina, mamaama*), 'earth that is powerful and strong, outstanding and supreme' (*tana makodi mayewa, tana mangunju marihi*), and 'the flat, smooth lap, the soft gentle suckler' (*na malinjaku babana, na malàmbi homuna*). The first two pairs of phrases are generally reminiscent of those used to refer to God, while the third suggests the image of a nurturing parent; in addition, like a living being, the earth is spoken of as having 'skin and fat, a liver and a heart' (*tàda lala, eti puhu*).¹ Accordingly, Rindi described the earth as the source (*pingi*) of all life. But, on the other hand, they also represent it as the abode of malevolent spirits and hence as something alien and potentially threatening to life.

Directly relevant to, though not co-extensive with, these contrasting aspects of the earth is the distinction of hot and cool land or earth (*tana mbana* and *tana maringu*). The terms are applied in several different ways. In the widest sense all land is hot, which is to say infused with spirit(s) and so potentially dangerous if treated improperly. This is shown by the reason the Rindi give for building a house with a raised floor, namely, because the earth is too hot for humans to dwell directly upon it. Land given over to habitations and fields, however, is spoken of as cool, since before an area is turned to human use a

cooling rite must be performed in order to placate and displace its original spiritual inhabitants. As these spirits are thought to have been present on the land before the arrival of the ancestors, it may be said that the Rindi see themselves as intruders, deriving originally from the sky or, in any case, from overseas, who must respect the prior claims of these indigenous occupants. Occasionally, the Rindi attribute death, illness, and persistent or disturbing dreams to the 'rebuke of the earth' (*pakaleha na tana*), which can result from a person's house being located on land that has not been rendered sufficiently cool. While the term 'hot land' can thus refer simply to land which has yet to be cooled, however, in its narrowest sense it denotes particular places which are inhabited by numerous spirits. Such places can never be cooled, and it is therefore prohibited to open settlements or fields there.

Since habitations are necessarily cool, while land that is hot lies beyond the area of (actual or potential) human settlement, in this context, then, the contrast of cool and hot corresponds to that of inside and outside. As is particularly clear with regard to the raised house and elevated village, one can further discern here a correspondence between the earth, the outside, and the below. The earth is thus what lies beneath and outside the house, while one expression for the act of leaving the village to defecate is *lua la tana*, 'to go to the earth'. In addition, various spirits identified with areas outside human habitations include in their names the word *tana* (earth). In accordance with its auspicious and inauspicious aspects, two broad classes of spirits associated with the earth and the outside can be distinguished in Rindi. The auspicious sort comprises manifestations of tutelary spirit that benefit mankind, most of which are the object of organized rites. The other variety embraces spirits identified with the heat of the earth, which are generally malevolent. I shall begin with the second sort.

1. Spirits of the Outside

The Rindi distinguish several varieties of malevolent earth spirits. One sort, the *patau tana*, 'inhabitants of the earth', are associated with particular locations on uninhabited land. The name usually refers to a frightening, malicious sort of being which young Indonesian speakers sometimes refer to as 'Satan'; but it can also include the more benign *maràmba tana*, 'lords, nobility of the earth', to whom the former are subordinate.² The two sorts of spirit are further contrasted in several

other ways. The earth lords are described as light-complexioned, beautiful, finely-dressed, and often small, while their subordinates, which I shall hereafter call demons, tend to be dark, ugly, and large. While both ordinarily appear as snakes,³ the earth lords take the form of pythons and other large, decoratively marked species, whereas demons appear as smaller, more common varieties. Poisonous green tree adders are their dogs; wild swine and deer are respectively their pigs and goats. Both types of spirit, though particularly the earth lords, are thought to reside in certain large trees, usually one of the several species of the genus *ficus*, noted for their great size and aerial root systems.⁴ Individuals gifted with 'clear vision' (*harii mata*) are sometimes able to see these in the form of large and opulent buildings. Such trees are often found growing atop or near stone outcrops and crevices, which are also considered the haunts of these spirits. In ritual speech, their domain is thus designated with the phrases 'the green forest, the stone enclosure, the rock cavity (and) cave, inside the *wàngga* (and) *karuku* tree (both species of banyan)' (*la uta muru, la kaba watu, la rokapu la liangu, la unu wàngga karuku*).

Encounters with demons take place at night and are typically brief. They may appear as monstrous humans, often abnormally large domesticated or wild animals, or in vaguer guises. Sometimes they are not actually seen, and their presence is revealed only by a sudden sensation of fear. They can also be detected by a strong odour, variously described as like that of a goat, perfume, or western medicine. Like the earth lords, they are especially prevalent about full moon. Though demons usually do no more than give fright, contact with them occasionally has more serious consequences. Some years ago, a friend of mine fell asleep while guarding a field of ripening maize at night. He had a dream in which a large monkey jumped on his back and bit him in the neck; and the following morning his head was swollen and he became very ill. Ever since he has periodically suffered from hysterical fits, during which (as I once witnessed) he talks and sings wildly, runs great distances, and climbs trees. At these times, he claims, the monkey is always present. His affliction has thus been diagnosed as the consequence of his having slept on land which, contrary to expectation, was hot. The monkey is actually a demon which inhabits the place.

The earth lords, by contrast, are often regarded as potential benefactors, at least of certain favoured individuals. There are persons in Rindi who are reputed regularly to enter the *patuna*,⁵ the domain of these spirits, access to which is provided by the large trees in which

they reside. To enter this realm, one must be favoured by a spirit familiar (*ariyaa*, 'guest, associate') who, usually in human form though sometimes as a snake, invites the person to follow him there. The familiar is invisible to other people. The person must undress so that he enters naked; he is later given new clothes by the spirits. It is impossible to follow someone into the *patuna* as his footprints disappear midway along the journey. Persons who enter this place may be absent for a few hours or days or as long as a month, but contrary to Wielenga (1919d:309), it was denied in Rindi that people might disappear altogether in this way, and I never heard of spirits abducting people and carrying them away to this place.

Association with the *patuna* is believed to confer invulnerability to accidents, injury, and the attacks of witches. This is most commonly secured in the form of small stones called *watu kaborangu* (*kaborangu*, 'bold aggressive', also has the connotation of invulnerable). As the Rindi were reluctant to talk about such things, my knowledge of them is rather limited. There are, however, two sorts of stones, one male and one female, and they are able to reproduce themselves. Sometimes they are given directly by the inhabitants of the *patuna*; otherwise their location is revealed in a dream or they simply appear in one's sleeping compartment. It seems not always to be necessary, then, actually to enter the *patuna* to obtain such objects; and in some cases they had been inherited. To invoke their protection the person must keep them in his sleeping compartment or carry them with him when away from home. The stones are also placed in coconut oil, which is then applied to the forehead, the centre of the chest, and the small of the back. Charms consisting of the roots or bark of particular plants, as well, may be obtained from the earth spirits.

The efficacy of such objects depends on the observance of certain prohibitions, particularly dietary restrictions, imposed by the spirit patron. In one case, a recipient was admonished not to eat green vegetables; in others, chicken eggs or various sorts of meat were not to be eaten. It is quite common in Rindi for individuals to abstain from eating certain foods on the pretext that to do so would make them ill, mostly, it seems, with a rash or other skin disease; and such preferences are often ascribed to the person having associated with earth spirits. Interestingly, breaches of clan food prohibitions, too, are usually said to result in a skin ailment. As noted, dietary restrictions can also derive from accepting a cure from another party, as, for example, when a person places himself under the protection of the *marapu* of another clan. Similarly,

two friends of mine abstained from eating pork because they had obtained charms and treatments from Islamic Endenese. What is common to all these cases, then, is the idea of subordinating oneself (or one's soul) to a protective power in order to derive essentially spiritual benefits.

One young Rindi man, who once received two stone charms from a spirit, was required to take them with the left hand, and when away from home to carry one on his left side. He was also enjoined to avoid all contact with corpses. (Because he chose not to follow these injunctions, however, the stones subsequently disappeared.) Unfortunately, I do not know how general these ideas might be. The avoidance of corpses, though, does suggest an antipathy between the realm of the earth spirits and the human domain of the house and village, where the dead are kept and buried. I was also told that some people who hold such charms will not drink water from the storage jars kept inside the house, but only from the pots in which water is collected, lest the charm lose its efficacy. The apparent association of earth spirits with the left is similarly suggestive of their opposition to the inner, human order, which, as noted, is governed by the principle of 'movement to the right'. The same informant told me that the stones he received comprised one male and one female member. The former was red, shiny, and sharp at both ends, while the latter was black, dull, and blunt at one end. He was instructed to carry the red, male stone on his person while travelling and to leave the black, female stone behind. This accords, then, with the contextual association of the male with the outside and the female with the inside of the house. Another case in which red and black are contrasted as male and female is the idea that bull and cow crocodiles are respectively of these colours. (The symbolism of colours is further discussed in Chapters VIII and IX.)

The Rindi say that if a man should marry and have children in the *patuna* his human wife or her children will die, or he will die. Thus childlessness is often ascribed to involvement with earth spirits. These ideas provide a further indication of an antipathy between the human order and the outside spirit realm. Indeed, I often detected a note of disapproval in their attitude towards persons who are supposed habitually to consort with earth spirits; and it is a subject which is not spoken of openly. Though it is not unequivocally restricted to any social class or to either sex, moreover, such behaviour is commonly attributed to persons who are in some way socially marginal. I was also told that the earth lords especially favour people who are *kam-*

bànga, 'mute', i.e., unsociable, withdrawn, or uncivil.

Another type of malevolent earth spirit is the *maru tana*. *Maru* is a form of *marungu*, 'witch'; accordingly, these beings were once described as earth spirits who are witches. Indeed, so closely do they appear to resemble witches that I often got the impression that they were one and the same thing. Other names for this sort of spirit are *wàndi tana*, 'wild spirit of the earth', and, sometimes, *ndewa tana*.⁶

While they may congregate in certain spots and at particular times, in contrast to demons (*patau tana*), the *maru tana* seem to be ubiquitous; and it is these spirits, especially, that are identified with the heat of the earth that must be contained beyond a boundary. If crops are planted on uncooled ground, therefore, the *maru tana* will destroy them. They can also cause illness. The morsels of food from offerings dedicated to the ancestors, which the priest drops through the floorboards of the house, are said to be for these spirits. (In this context, then, the notion of hot with regard to the earth is applied in the widest sense, for in other respects the land on which a house stands is necessarily cool.) The *maru tana* also devour the congealed blood and feces of sacrificial animals, and the effluence of corpses,⁷ and like human witches, they are attracted to persons who are ill or have suffered an accident, in particular one involving blood loss. As noted, in these circumstances, the sufferer's soul is particularly susceptible to attack, as it becomes estranged from the person and roams freely outside the village. When a new bride, an important guest, or someone who has been absent for a time (in a couple of instances, someone who had gone elsewhere to obtain medical treatment) enters or re-enters the village, a priest must first place an offering outside the gate to ensure that any spirits which might accompany the person do not also gain entry. The rite is called *pamaratangu* (or *pahàmburu marata*), from *marata*, 'what cuts off', which refers specifically to uncooked rice and a raw egg that serve as the offering. A liking for raw food is one of several features the *maru tana* share in common with human witches; so in this respect both sorts of beings are distinguished from normal humans, who consume mostly cooked food. So long as the proper ritual precautions are observed, however, the *maru tana* appear considerably less threatening than witches.

A rather similar sort of malevolent spirit is the *kawuu tana*, 'smoke, steam of the earth' (*kawuu* also refers to a sullen, angry facial expression), sometimes described as *mbana tana*, 'heat of the earth'. The Rindi identify these beings with various epidemic diseases said to be

seasonal in occurrence; thus by contrast to other types of earth spirit, the *kawuu tana* are thought to be present only at certain times of the year, and they are more completely designated as 'smoke of the earth, the annual catastrophe' (*kawuu tana, àkatu ndaungu*). The *kawuu tana* derive from the Base of the Sky whence they are summoned by the ancestors and by God to exact retribution in the form of illness for human failings. However, I was also told that some of them come from the opposite cosmological extremity, the Head of the Earth, and that they may enter a village from either direction. But whatever the case, it is clear that the *kawuu tana* hail from outside the domain, or, as this was once expressed, from outside Sumba. In contrast, the *maru tana* and other spirits are so to speak indigenous. The *kawuu tana* sometimes appear in dreams or in the waking state as short, stout, hirsute men with dishevelled, frizzy hair. Once their appearance was simply described as like that of 'foreigners', while on other occasions they were identified with an aboriginal population, also reputed to have had frizzy hair and to have practised cannibalism. In both cases, therefore, they are represented as aliens. Another idea is that when the *kawuu tana* come to exact retribution, they are guided to their destinations by *maru tana* and witches.

The *kawuu tana* are especially prevalent during the early part of the wet season, traditionally a period of food shortage and hardship. Just before the onset of the rains, therefore, the Rindi hold rites to prevent them from entering the villages (see Section 3 below). Some elderly informants thought the rites were formerly repeated just after the wet season, in the interval (from about May to July) before the beginning of the *ndau wandu*, the driest, hottest part of the year.⁸ This period, which is marked by numerous restrictions, is called the *wula tua*, 'revered month(s)', and is characterized as a time of illness, death, and disaster. One informant thus once identified the *kawuu tana* with the dust and the spiralling winds (*kawuluru* or *kawularu*) of the *wula tua* and the early part of the dry season. (Like other Indonesians, the Rindi identify wind, *ngilu*, in general as disease or the agent of disease; it is thus often said of an ill person that he has been 'struck' or 'touched by', *nggàna*, the wind.) Illness which occurs during the main part of the dry season, however, was said not to be brought by the *kawuu tana*.

A type of intrusive spiritual force very similar to, and perhaps a form of, the *kawuu tana* is the *maranga*. The term otherwise denotes the common cold and other minor (often respiratory) ailments. Though, as noted, the *kawuu tana* seem to be linked with both major cosmo-

logical directions, I also encountered the idea that the *kawuu tana* and the *maranga* are distinguished by their derivation from the Base of the Sky and the Head of the Earth respectively. Since *maranga* can be glossed as '(what is) moist', this is consistent with the fact that the Head of the Earth is the source of the major rivers. If there is illness in the village, especially during the wet season, a rite called 'to eject the *maranga*' (*paluhu maranga*) is performed on the front verandah of the oldest house. This is an attenuated version of the ceremony designed to ward off the *kawuu tana*. If one is assiduous, I was told, the rite might be performed as a precaution once every lunar month about full moon (see Wielenga 1910b:206), which in Rindi marks the point of transition between the waxing and waning halves of the lunar month (*hakawita hunga* and *hakawita m̄rahu*.) As I have noted, other sorts of malevolent spirit are also prevalent about this time. These ideas, as well as the association of the *kawuu tana* with the onset of the rainy season and the period between the wet and dry seasons, therefore, suggest a connexion between temporal transition and spiritual danger.

Two other sorts of malevolent beings found in the wild are worth mentioning here. One, the *kamawa* head (*katiku kamawa*; *kamawa* is a type of cephalopod) is a bodiless human head with long white chattering teeth which appears at night, rolling on the ground. The creatures seem to be especially prevalent at places near the sea. Because *kamawa* heads are extremely 'hot', a person who sees one should immediately have a priest make an offering to his clan ancestor in order to place a boundary (*padira*) between the thing and his soul, so that he will come to no harm. A similar procedure may be carried out for someone continually bothered by demons (*patau tana*) or by giants. Giants, the other variety of malevolent beings referred to above, are called *makatoba*, literally 'mad men'. They are described as large, stupid, extraordinarily strong, hairy, and white-toothed humanoids which live a rough uncivilized existence in dense forests and caves.⁹ Once giants lived in harmony with men; and because of their reputed strength they are credited with the construction of certain ancient, particularly high and thick stone walls that enclose some settlements in other parts of eastern Sumba. On account of their liking for human flesh, however, they were later separated from normal humans by God.¹⁰

Wielenga (1913) records a number of Kambara narratives in which giants enter human settlements in disguise, typically with disastrous results.¹¹ But while they are therefore generally regarded as dangerous, the creatures are said still occasionally to consort with individual

humans, sometimes to their benefit. Thus a friend of mine claimed that when he was a boy a female giant – who at the time was involved in a clandestine affair with one of his mother’s brothers – befriended him and assisted him with his chores. She addressed him as ‘grandchild’ (*umbuku*). (Regarding the previously mentioned association of spirits with radiance, it is worth noting, also, that this ‘woman’ was said to have worn a shiny skirt.) Many of the details of his story thus closely corresponded to traditional narratives (*analalu*) which feature a character called *Àpu* (Grandmother) *Kàmi*, an old woman living alone in some desolate spot, who provides the hero, typically an orphaned child (*analalu*), with information that crucially affects his fortunes.¹² In other cases she raises the orphaned hero or heroine to maturity. What is more, in Rindi Grandmother *Kàmi* is in fact said to be a *makatoba*. Wielenga (1910d:310) mentions the idea, which I did not hear in Rindi, that these giants (in the traditional narratives, at any rate) weave women’s skirts from their long hair. Whoever is able to obtain one will enjoy good fortune, but in return the recipient, who appropriately enough seems always to be an orphan, must forfeit the souls of his parents. This is reminiscent, then, of the idea that benefits derived from the lords of the earth entail certain restrictions and are often obtained at the cost of other aspects of well-being.

The *kamawa* head and the *makatoba* differ from the earth spirits described above in that each seems invariably to manifest itself in a single, embodied form. Nevertheless, several of their features clearly link them with these other beings. Thus some people are unable to see giants, because ‘their souls are not suited to it’ (*nda hamangunanya*). A person who encounters one visually, though, might still be harmed by the experience. In such an event he should therefore place salt in his mouth: if it remains salty his spirit (*ndewa*) will endure, but if it is tasteless he must die. As noted just above, the *kamawa* heads similarly cause a person harm simply by appearing before him, rather than by direct physical attack. Thus both sorts of beings seem to be essentially spiritual in their nature and mode of operation. Giants are also said to possess the spiritual power called *wàndi*, which is what makes them wild. Indeed, I think *wàndi* might be an attribute of all malevolent beings associated with the wild. In a narrative I recorded, the *wàndi* of a male giant resides in its pubic and head hair, and by burning these the creature is transformed into a normal human being.¹³ The *wàndi* then flees, returning to the forests and caves whence it came. Accordingly, a prominent theme in this story is the giant’s great fear of fire, which

evidently figures here as a symbol of the civilized state. Except for occasional forays, therefore, the creatures are generally characterized as wary of man and his habitations.

As an addendum to this section it is worth briefly mentioning several respects in which Rindi ideas concerning uninhabited land resemble those that concern the sea. As noted, being the place to where harmful impurities are removed, the sea, too, is characterized as 'hot' and threatening. It is also regarded as a domain of spirits; and a common theme in myth is the idea that, after a certain depth, sea water becomes dry land, where fish and crocodiles assume human form and live like men. Myths concerning the ancestors, especially, reveal instances in which these beings provide favoured individuals with assistance. In these regards, then, they resemble the earth lords, who can appear as snakes.¹⁴ It hardly needs to be pointed out that, like the uninhabited land, the sea is an outside space. Regarding its connexion with the first ancestors, however, the sea further suggests a transitional area between the land (or earth, *tana*) and the sky. Indeed, as was previously shown, it is linked with the sky, specifically the Base of the Sky, in ritual speech.

2. *Witches*

As noted, witches are called *marungu*. The more usual name, though, is *mamarungu* (*ma* is the relative pronoun). Since *marungu* can also mean 'greedy, gluttonous', the term might be translated as '(people) who are greedy'. Avarice is indeed a major trait of persons who are witches, and they are said always to be requesting things in a forceful and persistent manner. Witches are also thought to be motivated by envy, hence they are further known as *tau pawunu*, 'jealous people'. I do not propose to record here all I heard concerning witches in Rindi, but only to consider how their supposed attributes link them with other sorts of malevolent beings discussed above.

Witches operate by assuming a spiritual, incorporeal form. The body of a witch is inhabited by the power called *wàndi*, which, in the shape of a snake, scorpion, mouse, or other noxious creature, is able to leave by way of his various orifices.¹⁵ When this occurs, while the witch is asleep at home or outside the village, he disappears, later becoming re-embodied when the *wàndi* animal returns.¹⁶ While thus invisible, witches are able to fly, and they may ride on, or take the form of, crows, owls, hawks, and, in particular, the bird called *kuu* or *kui*;

they might also ride on a dog or a pig. It is during such times that witches are able to cause harm. The attack of a witch occurs at night while the victim is asleep. In this regard it is significant that it characteristically involves operating invisibly on the victim's soul (*hamangu*), not visibly on his physical body. A witch can thus harm a person by striking or stabbing him with invisible instruments that leave no mark. Witches in concert will also steal a soul, often that of someone who is already ill, and transform it into a buffalo or pig which they then slaughter to bring about the victim's death; when they later divide the carcass, it becomes human flesh.¹⁷ This idea is related to the common claim that witches eat people. Though this was occasionally qualified to mean that they eat their souls, in some cases it was insisted that the actual flesh of a victim, not just his soul, had been devoured. Witches are also said to consume corpses and unborn fetuses. Other means they may employ to kill or cause illness include cursing (*hupa, dekangu*), which results in a violent or 'hot death' (*meti mbana*, see Chapter IX); placing animal or human hair, fingernails, or human flesh in the victim's food or, while he is sleeping, in his mouth; burning his hair cuttings, thus causing head pains or madness; and sucking his blood. Though this last method, in particular, might be construed as an attack on the victim's physical person rather than his soul, it seems relevant that it leaves no physical trace of injury, and, like cursing, was said to be done while the victim is asleep. The possibility of witches misusing the hair is apparently one reason why cut hair should be collected and placed beneath a shady tree. If any were lost, I was told, illness would result, and if it were burnt the head would become hot. These ideas are also consistent with the association of the hair with the soul (see further Chapter VIII, Section 5). Little care is usually taken with other bodily appurtenances, though it is said that nails should not be pared at night, which I think might also apply to cutting the hair.

Interestingly, since persons most commonly identified as witches include outsiders, marginal persons (e.g., vagrants and idlers), and those of low rank, the spiritual powers of witches contrast sharply with their worldly position. Informants' statements further suggested that, while they are embodied, witches tend to be timid and scared of normal persons, though as noted they are also characterized as forceful and demanding. It is perhaps also significant in this regard that more women than men seem to be suspected as witches in Rindi, and it was once even claimed that most witches are female. This, however, prob-

ably refers more to symbolic femininity than to actual sex, which as I shall show just below is consistent with other associations of witches.¹⁸

Several reputed features of witches connect them with the outside, specifically, in some instances, with uninhabited places outside the villages. The hair of a witch, I was told, is dishevelled, tangled, and will not part when combed; and when they are seen at night, travelling or sleeping at the edge of a path, it hangs down to cover their faces. At these times, they are also invariably naked. Witches' saliva does not turn red when they chew betel and areca; thus their teeth, particularly their canines, always remain white. (By implication, then, the betel fruit stays green.) When witches gather together to co-ordinate their evil designs they always meet outside the village. All these ideas, then, link witches, like malevolent spirits, with the wild and so place them in opposition to ordinary humans. So does their previously mentioned liking for raw food. That their hair should cover their faces is indicative of an absence of social control and the moral sense which in Rindi is symbolized by an uncovered forehead (see Chapter VIII).¹⁹ I have shown that white teeth are characteristic of embodied spirits of the outside; normal people have blackened teeth. The notion that witches go about naked, of course, also places them outside the bounds of civilized society.²⁰

Witches are further associated with the category *murū*, the word for 'green' (including lighter shades of blue and greenish yellow). Thus their eyes are green; the name of a mythical female witch is Kahi Green Eyes, Powerful Green Eyes (Kahi Muru Mata, Muru Mata Mbiha); and green flares (*maroka* or *maduru*) seen in the night, which are thought to be the glow of the ends of their hair or their spittle, reveal witches on the move.²¹ In Rindi, *murū* generally connotes the earth and the wild. The term is also used to refer to special powers held by members of particular lineal groups. There are a great many varieties of such *murū* in Rindi, and nearly all are identified with (often minor) ailments and diseases. As was shown in the previous chapter with reference to the 'power of the monkey' (*murū buti*), a power of this sort may be regarded as an attribute of a particular clan ancestor. I am not certain, however, whether this is invariably the case. At any rate my enquiries did not always reveal such a connexion, though this may partly be due to the fact that the ability to cure a disease, which is entailed in the possession of *murū*, is sometimes passed from mother to daughter, thus potentially obscuring any connexion with a patrilineal clan ancestor. Whatever the case, all types of *murū* are conceived as spiritual

agencies that can exact revenge for offences against their possessors. A party that possesses *murū* will therefore suspend icons made of leaves, sticks, and the like around fruit-bearing trees (but not cultivated fields), as a warning to trespassers. Should someone contract an illness diagnosed as *murū*, he must then approach the owner to obtain a cure. Except for major *murū* such as the power of the monkey, which involve extended treatment, this normally requires the payment of at most a small chicken and a metal pendant, or nowadays money. The ability to cure, the remedy, and the icons are also called *murū*.

In a more general sense, *murū* refers to all medicines and to efficacious media such as spells and charms. These are derived from the roots, leaves, or bark of wild plants and trees that grow outside human habitations (another general term for 'medicine' is *tàda ai*, literally 'tree bark'). That witches are linked with the category *murū*, therefore, is consistent with both their possession of extraordinary spiritual powers and their connexion with the outside, the wild, and the earth. In myth, witches are associated with the Head of the Earth.

Since the Rindi expressly contrast day and night as masculine and feminine respectively, the association of witches with the night accords with their symbolic femininity. It is, of course, also consistent with their spiritual nature.²² Being active at night, witches are said to sleep during the day; so their activities are ordered inversely to those of normal people.²³ Inversion is also shown by their association with the left, which as noted may be a feature of malevolent spirits in general. Thus the crown of hair, which should be located in the centre of the head or slightly to the right, is found on the left in witches, and in response to questioning I was told that many are left-handed. Not surprisingly, the left is considered the inauspicious side in Rindi. A general dislike of left-handedness is expressed in the phrases *pakalai hama limangu*, *panjala hama etingu*, 'left like the hand, faulty like the liver', which was explained to mean that a person is left-handed because of 'faults, mistakes' (*njala*) in his liver, which is to say his character.²⁴

Rindi ideas also associate witches with periods of temporal transition. Thus because they are especially active at sunset and sunrise, when they respectively leave and return to their homes, these are regarded as dangerous times, and activities that might result in accidents should then be particularly avoided.²⁵ Witches are reputed to gather about the time of the new moon, specifically, I was told, on the third night of the new moon, an idea that recalls the inauspicious nature of the number three. Another dangerous time for witches, though more

generally as well, is *heru àkату* (*àkату* is 'dangerous, disastrous'), which by different methods of reckoning falls either two or three nights before the moon is at its fullest. The only clear instance I encountered of an association of witches with spatial transitions, on the other hand, was the idea that they often, though not invariably, enter a house by one of the four corner roof spars (*kamundu manu*).

The association of witches with inauspicious, uneven numbers, in particular the number seven, finds expression in rites intended to placate them. Thus in one rather elaborate version of the ceremony I witnessed,²⁶ seven broad leaves were laid in a row on the ground in front of the house. On each of six were placed seven chips of silver, seven pieces of areca nut, seven slices of betel, and seven slivers of raw meat with a pinch of uncooked rice. The seventh, main portion, called the 'mother's share' (*tanggu ina*), which was located in the middle, was then provided with eight pieces of each item, and the metal was gold. This was left in the village square, while the other six portions, called the 'children's shares' (*tanggu ana*) were taken outside. Two pairs were placed outside the upstream and downstream gates respectively and one portion was placed outside each of the two side gates. The significance of seven in this context apparently derives from its opposition to eight as a principal numerical symbol of completeness. According to myth, witches originated from a group of eight beings who, because there was insufficient food to go among them, killed and ate one of their number. The association of seven with witches thus accords with their insatiability, or otherwise expressed, the fact that they cannot be 'complete'.

As Rindi representations link witches with the earth, the outside, the feminine, the left, night, and uneven numbers, in these respects, as with regard to their spiritual mode of existence and malevolence towards ordinary persons, witches closely resemble the various sorts of earth spirits described above.²⁷ But witches differ from these in that they also exist as flesh and blood human beings and thus are inextricably part of the social order. In this way, they obscure the essential boundary between the inside world of men and the outside world of harmful spirits. Occupying the interstice between the two orders and moving freely between them, they are therefore regarded as considerably more dangerous and difficult to control than are the earth spirits.

3. *Altars, Boundaries, and Media*

The manifestations of spirit I shall now describe concern the earth in its positive, life-giving aspect. Thus one of their major functions is to provide protection against the various malevolent forms of spirit described above. Rites performed outside the house in Rindi mostly take place at one of a number of altars (*katoda*), which, according to their location, consist of a pile of stones or one or more flat stone slabs placed beneath a tree or wooden stake. The wood is the *maü*, that which shades or shelters the stone, and is considered masculine while the stone is considered feminine. Each altar is identified with a unitary presence comprising a male and a female spirit, which are simply referred to as the Lord (Umbu) and the Lady (Rambu). Though they too serve as intermediaries, these spirits are not called *marapu*, and contrary to Kapita (1976a:90), rites performed at the altars in Rindi are not addressed to the ancestors. A few ritual experts claimed to know the individual names of the various spirit pairs, but these turned out to consist of little more than phrases in parallel speech referring to the functions of the altars, and in my experience are rarely mentioned in invocations. Ordinarily, the spirits are indicated with the common name of the altar with which they are associated, which in turn is usually named after the place it occupies. The spirits can therefore simply be understood as a dyadically represented personification of the incorporeal aspect of the altar itself. Though there is no standard generic term for this type of spirit, some people in Rindi referred to them as *maramba tana*, 'earth lords', the name of the more benign variety of earth spirits found in uninhabited places. It seems significant, then, that many of the altars bear an obvious resemblance to the large trees growing near stone outcrops where the earth lords are thought to dwell.

The altar spirits, as I shall call them, can generally be characterized as particular manifestations of divinity connected with specific places and activities. They are also closely linked with the clan shrine (*pahomba*), which as noted earlier is prominently associated with life sources. This is shown by a myth that concerns the origin of both the shrines and the various altars.

After leaving their birth place at the Base of the Sky, the ancestors of the Sumbanese and peoples of neighbouring islands arrived at Ruhuku la Mbali, Ndima la Makaharu.²⁸ There they set up a large stone to serve as their common *pahomba* in order to link them with their

place of origin. Later, when they dispersed, they divided the stone among themselves. Thus the ancestors of the Sumbanese clans, when they eventually arrived on Sumba, set about erecting the fragment they had been given. After a while, however, they could no longer agree about the collective rites to be performed there; so the stone was again divided among the various clan ancestors in order that each might take a piece to the particular place where he was to settle. It was from these fragments that the various *pahomba* shrines and the different sorts of altars were first created.

With regard to the clan *pahomba* in particular, therefore, the original stone represents a social unity which subsequently became obscured through fission and geographical dispersal. That it is also a symbol of the unitary aspect of divinity is shown in the myth by the designation of both the original, entire stone and the fragment brought to Sumba as the 'all embracing *ndewa* and *pahomba*' (*ndewa mbulungu, pahomba mbulungu*). As noted, this is also one of the expressions used to refer to God.

The further significance of the altars is best approached by considering particular cases. The most important, within the village at any rate, is the *katoda kawindu*, 'yard altar'. This is usually located in front and just to the right of the oldest house, though occasionally it is moved to a more central location in the village square (see Plate Ib).²⁹ Since the altar serves all the inhabitants of the village, it is described as the 'general, communal altar' (*katoda ukurungu*).

While all altars are connected with one or another manifestation of the powers called *ndewa-pahomba* (see Chapter IV), in the case of the yard altar the association is particularly close. The altar (and the spirits present there) is thus spoken of as the '*ndewa-pahomba* which is nearby' (*ndewa marenī, pahomba marenī*). This suggests that the altar is the surrogate within the village of the distant *pahomba* shrine, located in a desolate spot outside. Like the *pahomba*, the yard altar is thus designated as the place to request 'the bridge of fecundity and prolificity, the way of wealth and mental acumen' (*lindi woru lindi bāba, lī wulu pangādangu*), and the 'end, extremity, highest manifestation' (*hupu*) of the 'bridge of fecundity, etc.'. It is here that these qualities, emanating from the world of spirit, are said to arrive among the living. The above phrases are a prominent and powerful verbal symbol in Rindi. Generally, they refer to a connexion between mankind and divinity (in which sense they are also occasionally applied to the ancestors) and hence to the means by which life and prosperity are secured.

'Bridge' (*lindi*) also suggests the continuity of life itself. These ideas are further reflected in the phrase 'firm binding' (*hondu mandungu*) as a reference to the wooden stake placed by the altar stone.³⁰ The yard altar is thus of special and immediate relevance to human well-being. The spirits of this place are invoked just before the clan ancestor in a variety of ceremonies, most notably those concerned with the life cycle; and in an elaborated form of the procedure for returning the soul of an ill person, the initial rite of recalling the estranged soul is held at this altar, as is the rite for summoning the souls of the deceased to attend the feast of souls ceremony (*langu paraingu*).

The yard altar also prevents disease, pestilence, witches, and other harmful forces from entering the house and village. The spirits of the altars at the gates (*katoda pindu*), which are considered subordinate to those at the yard altar, also assist in this task, as do the two altars located respectively at the river estuary (*katoda mananga*) and at the upstream boundary of the domain (*katoda katiku luku*). These altars thus mark and maintain important boundaries between the inside and the outside and between what is cool and what is hot. I shall return to this theme just below.

Other altars include one for horses and buffalo (*katoda njara, karimbua*), which is specifically associated with the 'spirit of livestock' (*ndewa banda*) or, as it is often simply called, the 'spirit of horses' (*ndewa njara*). This is located in the pastures. Rites are held here to ensure the fertility and welfare of livestock. There are also 'seashore altars' (*katoda mihi* or *katoda tehiku*) and 'altars of the chase' (*katoda patamangu* or *katoda ahu*, 'dog altar'), where offerings are made to request success in fishing and hunting. By contrast to those mentioned above, these altars are not so clearly concerned with boundaries, though they too are places to invoke divine protection. The various agricultural altars will be described below.

To ensure that they continue to fulfil their proper functions, several rites of renewal, called *pamangu katoda*, 'feast of the altars', are held at each of the various altars beginning just before the onset of the wet season in late November or December. Limitations of space allow me only to refer briefly to the earliest performances, which take place at the yard altar. The first of these rites concerns the previously mentioned *kawuu tana* spirits, whose arrival the Rindi anticipate at this time.³¹ On behalf of each party resident in or connected by descent or marriage with the village, a priest places a tiny metal chip on the altar stone as a token compensation for all misdeeds possibly committed by the prin-

cipal in the previous year. At the same time he recites a comprehensive (albeit rather perfunctory) confession in formulaic language. This is done so that the spirits of the yard altar and gate altars will refuse the *kawuu tana* admittance to the village. Later, a food offering in two parts is placed on the altar stone. One part comprises two pairs of half coconut shells, in each of which the priest places four chips of metal and a small quantity of betel and areca. In one of each pair he then puts a roasted chicken and cooked rice, and in the other a raw egg and uncooked rice. Since all this is intended for 'what is hot', i.e., the *kawuu tana*, one pair of containers must be placed outside the upstream gate and the other outside the downstream gate of the village. The food may not be eaten. As transgression itself, like its consequences and the agents of retribution, is classified as hot, this part of the offering seems also to represent the sins of the inhabitants, which in this way are removed from the village. The second part of the offering consists of four plaited bowls of cooked rice and chicken meat and is intended for the spiritual presence at the yard altar itself. As this portion is cool, it is not removed and may be eaten by the people in attendance. The prominence of four and eight in this rite provides a useful illustration of the ritual use of these numbers in Rindi.

Several days later, the villagers hold another rite at the yard altar. On behalf of the inhabitants the priest again puts chips of metal and a cooked food offering on the altar stone. Afterwards, he places additional offerings at each of the two or four gate altars, and at the altar by the gateway of the livestock corral (*katoda oka*), if the village contains such an enclosure. This performance, however, has a more positive purpose than the earlier one, namely, that of requesting continuing prosperity for the villagers, their livestock, and crops. By contrast to the earlier rite, the purpose of which is to expel and prevent the entry of things classified as hot from the village, this ceremony is thus exclusively concerned with obtaining coolness. One of its specific aims is to request a sufficient fall of 'cool rain' in the coming year. The contrast of hot and cool thus pertains to the two rites themselves as well as to the offerings placed outside the village and those left on the yard altar in the first rite.³² In both cases, moreover, the distinction articulates the two complementary functions of the altars: to keep dangerous spiritual forces from entering the house and village and to ensure prosperity. The duality is most clearly pronounced in usages and ideas that concern the yard altar. The subordinate gate altars, for example, serve mainly to preserve the boundary between the interior and exterior of

the village. In accordance with its recognized superiority, the yard altar thus represents a unifying force and the totality of the various other altars.

After the renewal rites at the village altars, similar, though somewhat more elaborate, ceremonies are held at the altar near the estuary and the one at the upstream boundary of the domain, responsibility for which is shared by clans resident in the two vicinities. Since all the renewal rites are partly intended to expel impurity associated with transgression, they provide the appropriate occasion for clearing the altars of debris and carrying out renovations. Traditionally, the village, also, was weeded, and the houses swept out, at this time, an undertaking regarded as an expulsion not simply of physical dirt but of illness and pestilence as well. The significance of keeping the village free of weeds was mentioned in Chapter II. Nowadays the cleaning has become somewhat neglected in Rindi; at any rate it seems not always to be done systematically on a single occasion. While clearing the house involves shaking the walls to remove dust, cobwebs, and the ubiquitous wasps' nests, I am not certain whether the walls were ever beaten at this time in order to expel spiritual impurity, as was done during a similar rite I witnessed in Kapunduku in north coastal Sumba, and as the Rindi do as part of the ceremony to remove the chaff (something which also is classified as hot) from the garden villages after the wet rice harvest.

The themes outlined above are also found among ideas and practices that concern the agricultural altars. The annual renewal rites at these places are held when the wet season maize, planted about late December, has reached a height of a metre or so (*hànggaroru*), while in the case of wet rice, the ceremonies should be performed when the stalks have reached their full height. Each cultivated plot has an 'altar at the head of the field' (*katoda katiku woka*; see Chapter II), a flat stone placed at the foot of one of the fence posts, which serves as the main focus of a variety of agricultural rites. The significance of the altar for the field and the crop is generally similar to that of the yard altar in relation to the village and its inhabitants. The spirits of this place, of which there is one male and one female, are thus said to keep harmful forces from the field and to care for the crop until it matures. The altar can also be described as both a medium and a symbol of the 'spirit' (*ndewa*) of the food crop, i.e., its vital essence.³³ In the centre of a complex of fields, which usually belong to members of a number of clans, there is found a *katoda bungguru*, 'communal altar', or as it is called in parallel speech, the *ina bungguru*, *ama bungguru*, 'mother and

father united, gathered together'. All the individual field altars are considered subordinate to this altar. The *katoda bunguru* is thus a higher medium and manifestation of the spirit of the crop, and in a way reminiscent of the relation between God and the clan ancestors, it might be said to represent the totality of the field altars.³⁴ Each complex of fields also has an 'altar at the land boundary' (*katoda padira tana*), located just beyond the area under cultivation (thus on hot land), the purpose of which is to maintain the boundary between the hot and the cool land. The Rindi therefore distinguish the *bunguru* and *padira tana* altars as things concerned with what is cool and what is hot respectively. The individual field altars thus combine the functions of these two major altars on a minor scale.

An area given over to wet rice cultivation is also provided with an 'altar at the water mouth' (*katoda ngaru wai*), where water from a river or stream enters the main irrigation channel. The male and female spirits of this place 'filter' (*kambàngi*) the water to remove what is hot, the 'sour and bitter water' (*wai puri, wai paita*), so that only cool water can flow into the fields. The Rindi also speak of a spiritual presence at the centre of a cultivated field (*padua woka*) which is distinct from and superior to that found at the altar at the head of the field. The centre, however, is actually marked with an altar only in the very largest of fields. In fact, the only one I saw was barely noticeable, consisting merely of a stone set into the earth; and the only rite I observed at such a place was the placing of a small offering in the centre of the major field of a wet rice complex prior to harvesting. Nevertheless, the rite held to cool a plot of land before it is first cleared is performed in the centre, and it was claimed that all rites carried out at the altar at the head of the field ultimately concern what is present at the centre as well. This idea expresses a general theme I shall consider just below.

Besides those present at the altars, the Rindi also speak of several pairs of male and female spirits inhabiting various parts of the house, which protect these places against the intrusions of harmful forces. Though the spirits were described as agents of the clan ancestor, and his 'younger siblings' (*eri*), like the altar spirits they too are not called *marapu* in Rindi. Beneath the house there is said to be one pair at the foot of each of the four main house posts and a fifth, superordinate pair at the centre of the house foundation, the area of ground over which the house is built (*padua watu uma*). In ritual speech, this last pair of spirits is called 'the ones who hold in the lap the foundation of the house, the fecundity of pigs and chickens, and the ones who hold in the

palms the bridge of fecundity and prolificity' (*malunggu mabàbaya na kandoka jala*³⁵ *watu uma, malunggu woru wei woru manu, hamana mandema lindi woru lindi bàba*). Before a house (specifically an ancestral house) is built, a rite is held at the centre of the area over which the building is to be constructed in order to remove the heat of the earth and temporarily to displace 'what is cool', i.e., the spirit couple who will guard the centre, while the area is cleared and levelled and post holes are dug.

These ideas are similar to ones that concern the very centre of a village or village square (*puhu* or *padua paraingu, kotaku*, see Chapter II), since the Rindi speak of this too as the place of a male and a female spirit, who are superior to those present at the various village altars. With regard to the notion, expressed in the ritual phrases cited above, that the spirits at the centre of the house foundation support this area, it is also interesting, then, that the centre of the village was once referred to as its 'sinew' (*kalotu*). A comparable idea is that the world is supported by a (house) post (*kambaniru*) situated beneath and at the centre of the earth (*padua tana*).³⁶ This figures in the Rindi explanation of earth tremors (*upungu*), which, they say, occur when a mouse gnaws at and digs around the base of the post. But there is also a large cat under the ground which guards the post and drives the mouse away. Both the deprivations of the mouse and the commotion of the cat chasing the mouse cause the earth to shake. When there is an earth tremor, therefore, the Rindi pound on the floors and walls of their houses and cry 'we are here' (*yianggama*), in order to alert the cat.³⁷ Once it was suggested that the earth may be supported by five posts, a central one with four others surrounding it, an idea which would correspond to the image of the spiritual centre of the house foundation encircled by the four main posts. Further examples of this four-five pattern, of which the yard altar and the four gate altars in the village may also be counted as an instance, are given in Chapter XI.

Besides the five spirit pairs located below the house floor, there is also a pair that inhabits the gutter around the periphery of the building, and another at the edge of the front verandah.³⁸ There are thus two groupings of spirits associated with the lower part of the house: those located beneath the building, mostly at points where the house meets the earth, and those situated at the outer periphery. The two groups can therefore be said to be concerned respectively with vertical and horizontal points of transition within the building. Only the latter – the spirits by the gutter and at the edge of the verandah – however, are

regularly addressed in rites. These rites are performed in the centre, at the edge, of the front verandah (usually just prior to a larger undertaking inside the house involving the clan ancestor) in order to request protection or remove extraneous, undesirable influences from the building, and before embarking upon or returning from an important journey. Essentially, then, they are intended to re-establish or consolidate the outer boundaries of the house. In these contexts, the spirits of the gutter and those at the edge of the verandah are addressed together as a unitary entity. The offering always includes chips of metal, food, and betel and areca. A small portion is dropped into the gutter while the remainder, placed in a coconut shell container, is put out in the village square or, sometimes, outside the gates.

Like those present at various of the altars, these spirits are thus clearly identified with boundaries and points of transition. The association is further revealed in the idea that the messages of liturgies recited on the front verandah are communicated to God and the clan ancestor by way of the rotan cords running along the central roof spar to the house peak. As noted, such cords, which are placed at points of articulation that distinguish various major parts of the building, are called the 'sinews' (*kalotu*) of the house, and are thought to preserve its form. I have also shown that the clan ancestor, as an intermediary between man and God, is associated with transitional points between the upper and lower sections of the house. There is, therefore, a general association in Rindi thought between such points and beneficent spirits that serve as a link with divinity in its positive, life-giving aspect. Points of transition, both temporal and spatial, however, are also points of access for harmful, extraneous forces. Thus a major function of the sorts of tutelary spirits discussed so far is to prevent the entry of malevolent powers. The transitions with which these spirits are associated, therefore, serve both to separate and to join, in which respect we are reminded of the two complementary senses of the notion of cooling, namely, to remove, keep out, or neutralize what is hot and positively to secure prosperity.

This seems an appropriate place to summarize the ritual use of metal in Rindi. All rites held outside the house – at the altars, the edge of the building, and elsewhere – include in the offering chips or fragments of metal. This is usually what is called 'white metal' (*àmahu bara* or *mabara*, 'what is white'),³⁹ i.e., silver and similarly coloured metals, though in more elaborate performances one half of the metal offering will consist of 'red metal' (*àmahu rara* or *marara*, 'what is red'), i.e.,

gold. The metal chips usually number four or eight. Some of the major altars, such as the *bungguru* altar, are also provided with a *kanotu*, a hollow stone or small jar hidden behind the altar stone. Pieces of beaten metal, ideally, I was told, one of gold and one of silver, are placed inside these containers at the annual renewal rites; and two pieces of each are inserted in the *kanotu* or beneath the stone when an altar is first made. In this latter context the metal was said to mark the 'seats' (*lata pamandapu*) of the altar spirits. Pieces of gold or silver are also inserted, with a portion of meat and offering rice, in each of the post holes when the ancestral house of a clan is built. While this may apparently be done at each of the 36 posts (see Chapter I), in this regard the most important are the four at the centre of the building.⁴⁰ Eight metal chips together with an offering of food and betel and areca are also placed at the centre of a house foundation during the rite, mentioned above, which takes place before building commences; and I was told that a similar rite is performed at the centre of the site when a village is founded. Though it seems not to be done in every settlement, in the chief village in Rindi, moreover, there are reputed to be pieces of gold and silver buried in the middle of the village square.

One clue to the significance of metals in connexion with at least some of the locations mentioned above is provided by Endicott's (1970:133-4) characterization of metals among the Malays as 'boundary strengtheners' which serve to repel intruding spirit. But whereas among the Malays, according to Endicott, all forms of spirit are afraid of metal, especially iron, in Rindi they seem, on the contrary, to be attracted to it.⁴¹ Metal in Rindi is thus often used to invoke a beneficent spirit which will lend protection to a given area or serve as a medium of divinity, while metal offerings given over to malevolent spirits are expressly represented as a propitiation.⁴² While metal fulfils similar purposes in the two societies, therefore, it is seen to do so in rather different ways. It is clear, moreover, that the pieces of metal placed at the altars and elsewhere outside the house have the same significance as the metal relics consecrated to the clan ancestor (see Chapter V, Section 3). The chips of metal placed in the bowl of water used in cooling ceremonies should also be recalled in this connexion. That metal is usually absent from offerings dedicated to the ancestor, then, might be ascribed to the continual presence of these media in the peak of the house.

Like the spiritual forces with which they are identified, therefore, metals are linked with transitions of various sorts and can serve both to divide and to connect, or, in other words, to articulate.⁴³ Possibly it

is their hardness and durability which makes them suitable in this respect (see Endicott 1970:135), though as regards their use as media of divinity, radiance might be a more relevant quality.⁴⁴ It is also worth noting that, in addition to livestock, precious metals are the major symbol and criterion of wealth in Rindi; and wealth is considered to reflect divine favour (an idea which finds its clearest expression in their traditional narratives). Since gold, silver, and copper form a major component of bridewealth, or, stated more generally, gifts made to a party who is categorically or contextually a superior, metals can also be characterized as goods exchanged for the possibilities of life (see Chapter XVII). There is thus an obvious parallel between this usage and the offering of metals to spirits, particularly as a means of requesting prosperity from the (feminine) earth. As noted, metals are thought to derive from the earth; so in some contexts there is possibly also the idea of giving back to the earth what has been taken from it.

An important aspect of Rindi thought revealed in distinctions and relations among the different manifestations of spirit described above can now be explicated. As I have shown, the centre of a cultivated field, the house foundation, and the village and the central *bungguru* altar of an agricultural complex all provide instances of a centre identified with a spiritual power superordinate to those associated with related margins or boundaries. This agrees, then, with the general superiority of central or inner spaces over peripheral or outer ones illustrated in Chapters I and II. The locations just mentioned further resemble one another in that, by contrast to their margins, they do not regularly serve as places of ritual, and with the exception of the *bungguru* altar, they are not visibly or clearly marked in any way.⁴⁵ The first feature conforms to a general principle in Rindi religious thought, whereby the more exalted a spiritual entity the less often it is (directly) invoked. Thus, to cite the extreme case, God is never addressed in rites. The second feature parallels the anonymity and obscurity of God, and it is significant that in one or another context the terms *mahanggula*, *mahanganji*, which designate God as an inactive divinity (see Chapter V, Section 1), were also applied in Rindi to each of the four central locations listed above. It appears, therefore, that these instances of a superordinate centre are identified with divinity in its higher, distant, inactive, immobile, and undifferentiated (or totalizing) aspects, which is conceived in opposition to subordinate, more immediate, active, and specialized spiritual entities manifest at margins and boundaries. Accordingly, in rites the field altars, by contrast to the *bungguru* altar,

are addressed as *matimbilu halela*, *mahapangu halimu* (see Chapter V). As I shall show in Chapter XI, these distinctions provide the essential background to certain themes encountered in the division of spiritual and temporal authority between social groups.

4. Summary Remarks on Rindi Religion

The ideas outlined in this and the previous chapter show that the Rindi distinguish two major classes of beneficent, mediatory spirits: the *marapu* and the beings present at altars and other significant boundaries; and that, especially with regard to the house, these are distinguishable in terms of the oppositions of inside and outside, above and below (or sky and earth), and masculine and feminine. Regarding the last contrast, it seems relevant that whereas nearly all the clan ancestors are male, the altar spirits and similar entities form pairs comprising one male and one female member, with the latter in some cases being specified as the more important of the pair.⁴⁶ Another point worth recalling here is that while the *marapu* belong to particular patrilineal clans, the other class of spirits concerns groups defined simply on the basis of locality. Perhaps in this regard, however, the spirits of the altars, in particular, are better characterized as general and comparatively diffuse, rather than specifically feminine, manifestations of divinity. As I shall later show, in this and other respects they are essentially similar to further spirit couples the Rindi speak of, which are identified with places and objects that temporarily assume a spiritual importance in the context of particular rites.

Despite the ways in which they may be contrasted, however, it is clear that both the *marapu* and other forms of beneficent spirit serve similar ends, viz., the provision of prosperity, and protection against harmful forces; so there arises the question of how the two can be distinguished from one another in functional terms. Part of the answer seems to lie in the idea that the altar spirits, while hierarchically ordered among themselves, are further subordinated to the *marapu*. Thus the Rindi terminate major rites that concern the altars by invoking the *marapu* inside the house, in order to repeat to him what has been communicated at the altars. As noted, the spirits present at the various lower margins of the house were similarly described as the *eri*, 'younger (siblings)', 'subordinates', of the *marapu*. Since this designation is also applied to the *matimbilu halela*, the active servant or messenger of the clan ancestor (see Chapter V), it seems, then, that all lesser spirits are

identically conceived as agents of the *marapu*; thus in relation to the altars as well, the ancestors appear to represent a relatively inactive, inaccessible, and distant centre.

This interpretation is consistent with further expressions of the contrast of elder and younger brother (*aya* and *eri*) as it pertains to Rindi religion. As the successor and surrogate of the father, the elder brother, and in a wider context the senior line of a clan, in Rindi is charged with the cult of the ancestor and the ceremonial life of the group in general. Thus in contrast to the younger brother, who as I further demonstrate in Chapter XI is associated with the outside and, in some contexts, with worldly power as opposed to spiritual authority, the elder brother is identified with the inside, viz., the house and the village. Here it is also relevant to note the Rindi use of *aya*, 'elder', and *eri*, 'younger', to distinguish ritual undertakings that are relatively 'heavy' (*mbotu*), i.e., difficult, demanding, and costly, and 'light' (*halela*) respectively. In general, this contrast would apply to rites that directly concern the *marapu* and those that take place at the altars, in which respect the spirits of the latter can be described as a more easily approachable form of divinity.

The comparative accessibility of the altar spirits, and the fact that they are associated with the earth and, more directly, with the powers of *ndewa-pahomba*, further indicates that the altars provide a closer and more immediate link with divinity conceived as a life source. Thus whereas the ancestors represent the ultimate source of human life, the altars may be viewed as its continuous agents, a distinction I first noted in Chapter III with regard to the Base of the Sky and the Head of the Earth as, respectively, the place of origin of the first ancestors and the immediate source of fluids essential to prosperity and fertility. While the spirits of the altars and similar entities also preserve boundaries that separate the inside from the outside and thus lend protection against harmful, extraneous forces, the ancestors, as the founders and in a sense maintainers of the social order, on the other hand, suggest a more regulatory side of divinity, which imposes form on human affairs.⁴⁷

An analogue of these two aspects of divinity, I suggest, can be found in two basic forms of Rindi social relationship. First, the regulatory side of the ancestor's power appears to have a worldly equivalent in the agnatic framework of temporal authority that defines the internal order of the clan, and which is associated with the interior of the house. The altars, on the other hand, may be compared to wife-giving affines; for

just as one must go outside the clan to obtain wives, the means by which the group is able to continue and increase, so it is necessary to leave the house in order ritually to secure prosperity from the land and well-being in general. If one ventures too far outside, i.e., beyond the bounds of cool, inhabited (or habitable) land in the one case and outside existing alliances or permitted marriage relations on the other, however, one becomes exposed to potential dangers. While to some extent these can be obviated by means of ritual cooling, in both instances there is moreover a limit beyond which the necessary transformations cannot be effected. Thus just as certain marriages can never be rationalized, so there are areas of land which, because they are so hot, can never be made fit for human use.

In another context, therefore, both the altar spirits and the *marapu* are associated with a cool interior, and both then stand in opposition to harmful spirits identified with a hot exterior. A major difference between these two broad classes of beings is that the malevolent spirits of the outside do not serve as intermediaries of higher powers in organized rites. Indeed, intercourse with them is comparatively tangible and direct; and it is in accordance with this that most beings of this sort can assume an embodied form. In contrast, the ancestors and the altar spirits (except, in the first case, in dreams) seem never to appear in this way. Another difference is suggested by the fact that, while certain earth spirits, in particular the more benign 'lords of the earth' (*maràmba tana*), may also confer spiritual benefits, they do not do so regularly in respect of groups lineally or territorially defined. Their patronage is thus arbitrary, capricious, and individualistic; and such favour as they might provide is acquired at the risk of other aspects of personal well-being. Thus while, as I remarked above, some Rindi refer to the spirits of the altars as *maràmba tana*, others deemed the designation to be inappropriate in this case. The reason they gave for this was that the earth lords are found only outside the village.

Nevertheless, in relation to cult figures such as the ancestors and altar spirits, the earth lords might yet be viewed as an alternative – and, in a sense, more worldly – means of access to divinity. Recalling the opposition of elder and younger brother noted above, then, it seems significant that in narratives which feature two brothers as the main characters, the younger one often enters into an advantageous relationship with the spirit world of the outside.⁴⁸ Thus whereas the elder brother maintains a 'vertical', hierarchical, and collective relation between man and spirit, articulated by patrilineal descent and expressed

in established procedures which are the preserve of males, the younger brother seems to be associated with a freer, comparatively egalitarian, individualistic, and more direct mode of interaction between the 'horizontal' categories of inside and outside, which is open to both sexes. These distinctions thus further recall the masculine and feminine associations of the sky and the earth and, contextually, of the inside and outside.

The above contrasts also bear upon Rindi ideas concerning the souls of the dead. As noted, when conceived in opposition to the first ancestors, the dead are linked with the earth; and as I shall later demonstrate, like witches and earth spirits, they are manifestly connected with the left and the feminine. Yet it is also clear that, by contrast to these, the dead, like the *marapu*, are associated with the house and the interior of the village.⁴⁹ Indeed, the dead are said eventually to become *marapu*. Thus, in contrast to what is found in some other Indonesian societies,⁵⁰ the Rindi do not identify malevolent earth spirits with the souls of the dead; and with regard to the distinction of embodied (or half-embodied) and incorporeal spirits noted just above, it seems significant that they have no notion of ghosts of the dead that appear in tangible guise among the living. The Rindi thus maintain a fairly clear distinction between spirits that were once human beings and those which were never so, while among the latter they further distinguish beneficent spirits, which like the former do not appear in corporeal form, from essentially malevolent beings which generally do. And in each instance the division corresponds to a contextual application of the fundamental contrasts of inside and outside and cool and hot.

As a final note, it is useful briefly to consider again the *pahomba* shrines described in Chapter IV. As I have shown, these places are associated not only with the altars but, to some extent, with the spirits of the ancestors as well; while their location in desolate places, i.e., on 'hot land', and arguably their form, further calls to mind the *patuna*, the abode of external earth spirits and, in particular, the lords of the earth. Although the Rindi do not consciously identify the shrines with spirits of the latter sort, here we might also recall Kapita's (1974) definition of *pahomba* as a place where, *inter alia*, 'spirits outside the village' are paid homage.⁵¹ With regard to the contrasts between different sorts of spirits abstracted above, therefore, the *pahomba* shrine appears ambiguous. The reason for this, however, may be found in the apparent fact that it represents a totality of various forms of (benefi-

cent) spiritual power and hence the opposed attributes by which they are distinguished. Consistent with this interpretation is the unitary and all embracing character of the power called *ndewa-pahomba*, of which the shrine is regarded as the principal medium or source. Insofar as the altars in particular are associated with specific manifestations of *ndewa*, the notion of *ndewa-pahomba* would appear to be more closely connected with the earth, and with the Head of the Earth, than with the sky or the Base of the Sky. Yet other evidence indicates that Rindi thought does not distinguish *ndewa-pahomba* from other, more specific forms of spirit by reference to these oppositions. In other words, then, it can be seen as a totalizing concept which ultimately defies categorization in dualistic terms.

CHAPTER VII

BIRTH

The present chapter and the two which then follow each concern a part of the cycle of life and death and the progress of the individual, and the human soul or spirit, through various stages of being. A common theme, therefore, is transition, and I shall pay special attention to resemblances between usages and ideas that pertain to different points in the life cycle. Several common features are summarized towards the end of Chapter IX. Although it too may be viewed as but one of a continuous series of passages, the obvious place to begin is with birth. As I propose to show, birth in Rindi, like other major transitions, is a process rather than an event and is accomplished in several distinct stages (see van Gennep 1960:3; Lévy-Bruhl 1966:305, 308).

1. Conception and Pregnancy

The Rindi recognize that a woman must have begun to menstruate before she can conceive. Menstruation is called *mandapungu katàri*, 'to sit on a rag', *tàkangu ariyaa*, 'to be visited by a guest', and *pabaha laii*, '(time of) washing the skirt'. The last phrase refers to the garment used to staunch the discharge, which is washed and reused. When it wears out, it is discarded outside the village; it must never be burnt, for the owner would then suffer illness. Menses is said to occur once every lunar month (*wulangu*). Although some men thought it might regularly occur at some specific stage of the month (e.g., new moon, full moon, or the end of the month), women recognize that each woman has her own time. Menstruating women are not confined to the house. They should not, however, enter a cultivated field, since the discharge (in parallel speech called *wai kombu*, *wai kandara*, the 'liquid' of two trees from which red dye is produced) is thought to harm crops; the leaves of the plants, it is said, would become 'red' (*rara*), i.e., they would die.¹ I did not hear that bathing and combing the hair were forbidden during

menses, as de Roo (1890:572) claims.

Sexual intercourse is considered a necessary precondition of pregnancy. Conception is said to occur when a sufficient amount of male semen, usually referred to simply as 'what is white' (*mabara*, which also means, 'silver')² mixes with the female blood inside the uterus (*kaliku*). I also encountered the idea that a couple should copulate eight times to ensure conception, which thus provides another instance of the association of even numbers, and this number in particular, with fulfilment. Pregnancy can be induced by having an elderly women who is practised in the art massage the woman's body, or by administering a variety of indigenous medicines. I uncovered no definite ideas regarding what physical or spiritual attributes a child should derive from either parent. The two are thought to contribute about equally, though it was once suggested that the amount of semen might affect the child's body size. Nor was it supposed that a child of either sex should normally resemble its father or mother.

Pregnancy is called *paanakedangu*, 'to have a child', from *anakeda*, 'child, infant'.³ Another expression is *pakambungu*, from *kambu*, 'belly, womb', but since this term refers to pregnancy in animals as well, it is considered rather coarse. A pregnant woman is also described as 'heavy of body' (*mbotu ihi*) or simply 'heavy' (*halimbaru*). Pregnancy is first recognized by the cessation of menses. Other signs include blotches (*panu*) on the face and forehead and the darkening of the nipples. From about two to six months, the Rindi say, the soft area above the sternum (the *pinu ngahu*, 'top, surface of the breast') pulsates quickly and noticeably. Sluggishness is another general indication. Morning sickness, if it occurs, is not recognized as a complaint specifically related to pregnancy.

Some pregnant women experience food cravings. Thus to say that a woman craves ripe mangoes is a way of indicating that she is pregnant, or, by another interpretation, that she wishes to become so. It is not clear, though, that the preferred foods are of any particular sort, for bananas, papaya, fish, and meat were also mentioned. Pregnant women are supposed to be fond of chewing overripe betel fruit, hence to attribute this to a woman is similarly taken to indicate pregnancy. Onvlee (1973:42) says that because of this implication young unmarried women should not chew overripe betel. There is in these two ideas, then, the common element of the thing preferred being *rara*, 'ripe, overripe' or 'red', which possibly indicates that the woman herself is conceived to be in a comparable condition. An expectant father might occa-

sionally experience food cravings; if he does the child will be a boy.

There are several ways of predicting the sex of an unborn child. If the fetus lies towards the right or left side, or if the woman, when she rises to walk, first puts the right or left leg forward, or, when summoned from behind, turns to her right or left, the child will be respectively a boy or a girl.⁴ Another indication is the colour of her nipples: if they are particularly dark a girl is expected, and if comparatively light a boy. I never heard the idea, mentioned by Onvlee (1973:70), that if a woman is sluggish in her work or has difficulty in moving the child will be a girl. The sex of the child might also be foretold in dreams involving either male or female ancestors or typically male or female activities.

The traditional view of the length of pregnancy seems to be ten lunar months for a boy and nine for a girl. This apparently reflects, then, an association of males with even and females with uneven numbers, though in another context the reverse is suggested.⁵ Several persons, however, thought pregnancy should last ten months regardless of the child's sex, while younger people generally said it was nine. While the latter view evidently derives from the schools, adherents sometimes qualify it with the phrase *hakambulu wàngu la aü*, 'ten (months) including the time spent at the hearth', referring to the mother and child's period of confinement after birth. Confinement, however, in fact lasts several months; so the statement is perhaps a way of representing the total as even. If this were so, it would seem to indicate, also, that one purpose of confinement is to render the period of pregnancy complete. There is nothing that could be called a system of named stages of pregnancy. The time when the abdomen noticeably fills out, reckoned at about six months, is called *hei ihi*, 'ascending of the body', and the beginning of labour is called *kati kajia*, 'back bite'.

During pregnancy a woman and her husband are subject to a great many prohibitions, the number and variety of which suggest pregnancy to be a transitional period fraught with danger, especially for the unborn child.⁶ There is not enough space here to discuss the restrictions adequately. In general, though, they express the theme that certain behaviours, and actions performed on various materials, will result in a difficult or unsuccessful birth or cause the child to be deleteriously affected or deformed in particular ways. Interestingly, while nearly all the husband's restrictions I heard of refer to operating on some object or material (e.g., incising the ears of horses and buffalo as a mark of ownership, which results in the child having a harelip, split ears or nose, or more than ten fingers or toes), many of the woman's require her to

avoid dispositions or actions that the child might imitate. If she sits in a doorway, for example, the child will have difficulty emerging from the womb. The difference suggests, then, that the mother has a more direct influence on the unborn child than does the father. Only two of the twenty or so restrictions on the husband I recorded were of this type, namely, that he should not cut his hair or pull out facial hair lest the child be bald, and that he should not wear anything tight around the waist when the delivery is near, otherwise the birth would not pass quickly. Both parents are forbidden to engage in activities that entail tying, cutting, shredding, incising, spinning, and so on. Thus a pregnant woman should not weave, bind threads (for dyeing), or plait. The reason usually given for avoiding work that involves cords or thread (e.g., weaving, spinning rope, making fishnets, etc.) is that the birth would be *kaliutu*.⁷ While the word can in general be glossed as ‘complicated’, ‘confused’, ‘troublesome’, it specifically means ‘tangled’, and in this case was explained to refer particularly to the child becoming wound up in the umbilical cord.

It is most strictly required of a woman that while she is pregnant and until the end of her confinement she should avoid all contact with corpses. She and her child must not enter a house where there is a corpse, and if a death occurs at home, she must remove to another building. That a pregnant woman should not prepare dye from the indigo plant is possibly related to the fact that the plant in solution is reckoned to smell like a corpse. I shall consider this opposition further in Chapter IX.

A couple should forgo sex from four or six months of pregnancy, which is about the time the child’s body is thought to be fully formed, and until the child is weaned. One indication that they have failed to do so is an excess of what is described as a white, sticky substance (*kapera*) in and around the newborn child’s eyes, nose, and ears, which is thought to be the traces of the man’s semen. The substance is considered dangerous, particularly as it can hinder breathing, and thus must quickly be swabbed away. Even so, it is still thought probable that the infant will not thrive. If the couple have sex before the child is weaned, moreover, it will ail, have a poor appetite, become thin, and not be able to walk, since the semen is thought to contaminate the mother’s milk. They then say that ‘its father has stepped over (transgressed against) it’ (*na-panggaya paraina amana*), or ‘it has drunk the father’s sweat (semen)’ (*na-unungu wai hanggobungu amana*). The rule thus has the effect of spacing pregnancies, which in an eastern Sum-

banese context accords with a more general principle of seriality, whereby one task must be completed before another is begun. That a child becomes ill while taking milk may alternatively be due to either parent having indulged in illicit sex. But I also heard that a woman might tacitly allow her husband to consort with other, unmarried women during this time – preferably one of her ‘sisters’ – in order to alleviate the restriction and thus protect her infant.

Throughout pregnancy and until the child is weaned, a woman is subject to several food prohibitions.⁸ One of the most important is that she should not eat chicken’s eggs. Otherwise, it is said, the child’s tongue would be ovoid and mute, or he would be blind (possibly referring to the resemblance between eggs and a blind man’s eyes), and, after birth, he would contract a high fever or refuse to take milk. Eggs are often identified with young children in ritual. Thus an egg is always offered to deceased persons who died in infancy, and a baby is buried clutching an egg. This suggests, then, that the prohibition might relate to a symbolic equivalence of the egg and the child himself, or his soul.⁹ Other restricted foods include green vegetables, which can give the child diarrhoea. That these are called *ri maja*, ‘soft vegetables, (foods)’, while diarrhoea and related stomach disorders are known as *maja kambu*, ‘softness of the belly’, seems to provide the relevant connexion here. A species of large banana (*kaluu bokulu maràmba*) is said to cause the child’s spleen and genitalia to swell. In fact, all sweet foods – bananas, papaya, mangoes, and coconut milk – should be avoided, or at least consumed in moderation, for these foods, too, can result in damage to the genitalia. A person who is ill or out of sorts is also advised not to eat sweet foods. Bananas can also cause the child to be ‘tight’ (*kaha*) in the womb. Possibly some of the ideas concerning this fruit involve a phallic analogy.

A number of dietary restrictions apply only during pregnancy. Maize gnawed by mice gives the child blinking eyes (like a mouse). Chilli pepper harms his lips and makes his hair kinky and curly. A sort of crab (*karungu*) causes stomach pains. Squid harms the child’s brain and liver, making him stupid and indolent, and causes his limbs to smart. On account of the anger of the offended party, consuming food or betel and areca that is stolen would result in a difficult birth. Onvlee (1973: 70-71) lists several other restrictions that I did not hear in Rindi, notably that to eat an egg with a double yolk or a banana with two fruits within one peel would result in twins.¹⁰

A pregnant woman and her husband are barred from certain activi-

ties on which the unborn child is thought to have a harmful influence. Neither should go to the seashore or the river to fish, for the fish would 'vanish, be extinguished' (*màda*). Similarly, if the man were to go hunting, the party would have no success. The child in the womb, it is said, 'bars off' (*patipangu*) the fish and game.¹¹

There are several precautions others must observe in respect of a pregnant woman. Waking her can cause a miscarriage; poking her might result in a stillbirth; and frightening or alarming her can harm the child. In each instance, the governing idea seems to be that the child's soul will be disturbed and thus leave the womb (see Onvlee 1973:72). I noted that when a person is woken suddenly, frightened, or emotionally disturbed, his soul (*hamangu*) becomes detached from him. While the fetus is still in the womb, moreover, it seems the connexion between the child and its soul is rather tenuous in the first place, and so perhaps particularly liable to disruption.

A pregnant woman is advised to wash herself with *kabaru* (Indonesian, *waru*) leaves and partake of eel, so that her skin will be sleek, like the eel and the leaves, and the birth will pass easily. She should also avoid idleness, work in the sun, consume hot drinks, and walk up and down inclines in order to perspire, thus rendering her body 'light' (*halela*) and lithe. Particularly the last recommendation appears to be related, sympathetically, to the desire that the child be capable of easy vertical movement at the delivery. I shall further consider the significance of sweating presently, in relation to confinement.

2. *Pamandungu Pelungu*

Pamandungu pelungu, 'to make firm the rungs', is the first and among the most important of the rites that concern a person's development. It aims to ensure the healthy growth of the fetus, a safe birth, and continuing well-being in life. The rite must be performed after an even number of months of pregnancy. Two months, however, is too early, while eight, though possible, is considered a little late; hence the performance usually takes place at four or six months. Were the rite to be held at an uneven number of months, it is said, the child would 'fall' from the womb, thus revealing yet another instance of the inauspiciousness of such numbers.

At about six months, the fetus is thought to be fully formed and its sex determined. Before this, it is said to be 'flat' (*kambela*), i.e., not rounded or filled out. The Rindi also say that the fetus is at first an

unarticulated mass, and that at this time its limbs and other appendages are 'sliced' (*hangatu*) away from the torso.¹² Another idea is that the two lateral halves of the body are initially separate, only later becoming fused.¹³ Should the principal wish to request a child of a particular sex, therefore, the rite *pamandungu pelungu* should be undertaken at four months of pregnancy. But I was also told that if a boy is desired it should take place at four months, and if a girl at six months.

Pelungu refers to the wooden rungs or foot rests lashed to a tree trunk or house post to facilitate climbing. The phrase 'to make firm the rungs' thus entails the imagery of someone steadily and securely climbing (or descending from) a tree (see Onvlee 1973:68).¹⁴ The theme finds further expression in the phrases 'the rungs of heartwood, the firm bindings' (*pelungu maàtu, bibitu mamandungu*), which repeatedly occur in the accompanying liturgical speech. *Bibitu* is a stout cord wound around the feet to prevent slipping while climbing. Contextually, the expression can indicate either the object of the request or the being who fulfils it. Ultimately, this is God, who is thus addressed in this context as 'the most secure, the most firm' (*hupu la maundungu, hupu la mamandungu*).

The aim of the rite is further expressed with the phrases 'let not the melting pan be aslant, let not the stone of creation split (or 'shake')' (*àmbu na pahingi na kaba lala, àmbu na kawita [tanggingilu] na watu wulu*). *Kaba lala* (or *loja lala*), a large metal frying pan, here denotes the uterus, while *watu wulu*, 'creation stone', refers to the male penis, or, according to another explanation, 'that part of the fetus contributed by the male'. If these were to be unsteady or askew, therefore, like a man climbing a tree with rungs not tied firmly to the trunk, the fetus would then fall from the womb. In this and other rites concerned with birth, the phrases 'he who holds (in the palm) the melting pan, and clutches the creation stone' (*na mandema kaba lala, maàpa watu wulu*) refer simultaneously to God and the clan ancestor.

The rite *pamandungu pelungu* requires that one or more fowls be offered to the clan ancestor, the deceased, the spiritual presence at the yard altar (*katoda kawindu*), and to the powers of 'the heartwood rungs and firm bindings'.¹⁵ The minimal offering is a red cockerel (the most preferred sort of sacrificial bird in general), which must be free from imperfections, though according to the wealth and position of the principal, additional fowls, and among the nobility a pig, may be slaughtered as well. From the entrails of the cockerel the sex of the child can be divined. Thus, whether the two ribbons of flesh known as

the 'chicken bridge of the ancestor' and the 'chicken bridge of humans' (see Chapter I, Section 6) are connected, or 'cross' (*pala*), at the top (*ngora*, 'snout', or *katiku*, 'head') or in the middle (*bànggi*, 'waist') indicates a male or female respectively. This, then, is another context in which the male is associated with the above and the female with the below.

There are several further points worth mentioning with regard to the part divinity is seen to play in the creation of the individual. In ritual language, the advent of conception and pregnancy is announced with the phrases 'he has looked down upon his reflexion at (from, in) the base of the sky, he has looked searchingly at (from) the source of the sun' (*na-kaninuka la kiri awangu, na-hajiwaruka la mata lodu*). 'He' refers to the clan ancestor. It is interesting, therefore, that the notion of reflecting also occurs in the previously mentioned mythical idea that Sumba was brought forth from the waters of the primeval flood when first surveyed by the great bird, and the ancestor of a particular clan, i Mbongu i Mbaku (see Chapter V). For this reason the island is known as 'the land reflected upon by Mbongu' (*tana pakaninuna i Mbongu*). This suggests, then, that the genesis of a child and the coming into being of the present world are conceived in the same way and, further, that a child is a 'reflexion' of the clan ancestor. The places mentioned in these phrases refer of course to that part of the cosmos called the Base of the Sky; and as I have remarked, 'source of the sun' and 'base of the sky' are also oblique references to the male and female genitalia. The Rindi also refer to conception with the phrases 'it has become oily (or dark) at the head of the earth (or the head of the river), there is much thick hair at the base of the sky' (*na-paminangu [or pamitingu] la katiku tana [or katiku luku], na-marambangu la kiri awangu*). 'Black, dark' (*mitingu*), I was told, here relates to the dark clouds upriver that betoken the heavy rains of the beginning of the agricultural year. Like conception, therefore, the clouds are precursors and a precondition of fecundity and growth. Since this expression makes reference to both the Base of the Sky and the Head of the Earth, we should recall that in this opposition, too, the terms are associated with the male and female sexual organs. The significance of oiliness and thick hair is thus self-evident, though it is relevant as well that oiliness is a quality more widely associated with prosperity and prolificity in Rindi. It seems clear, therefore, that genesis and conception are thought of as operating on two parallel planes: in the interaction of male and female bodies and, through the agency of divinity, in a unification of the two halves of the cosmos.

3. Delivery

Delivery (*habola*)¹⁶ takes place in the female section of the house, by the main house post in the left back corner. During childbirth the woman squats on a wooden plank called the 'base of the spinning wheel' (*lata ndataru*) with her back to the hearth and supports herself with a rope suspended from the ceiling. A compartment with three walls is erected around the area. The open side is the one opposite that which adjoins the hearth, which is provided with an aperture (*katongu*) so the woman's back may be warmed by the fire during her subsequent period of confinement. During the delivery she thus faces towards the back of the house. As noted, houses may face opposite one another across the village square; so the woman's position is oriented only in relation to the house and not to any one of the principal directions discussed in Chapter III. Various preparations must be made before the delivery. A large earthenware pot in which bathing water mixed with the scented leaves of medicinal plants is heated, and a large coconut shell to serve as a washing bowl, must be made ready. The leaves, which the woman rubs on herself and the child, promote her recuperation and the baby's growth and health. Great care must be taken with the pot, for it is a bad omen should it break before the child is weaned. A new sleeping mat must be plaited for the child. This should be done by someone who can work quickly, as it must be completed in one day. When obtaining palm (usually lontar) leaves for this purpose, moreover, the leaves must gradually be brought down from the tree, not just thrown down as is usual, since the child would then suffer. The same applies when cutting firewood for the hearth: it must always be handled gently. In addition, the wood must be cut from the side of the trunk which faces the sunrise, the direction associated with life and prosperity. A supply of rags must also be made ready.

The Rindi refer to birth as 'to use the floor as mother, to regard the rags as father' (*inangu kaheli, amangu katàri*). When the woman begins her labour, a priest is summoned. Sitting in the right front corner of the house, with an offering of betel and areca before him, he addresses the clan ancestor and the child in order to request that the birth pass quickly. The procedure is then repeated at intervals. A key passage in this speech is 'make straight the bow of your (the child's) boat, set right your stern' (*pakunduhuya na katiku tenamu, patànjiya na kamu-rimu*). The birth is thus represented as analogous to the arrival of the clan ancestor on Sumba from across the sea (see also Onvlee 1973:75).¹⁷

Other phrases that express this analogy include 'the one who comes from the base of the sky, the source of the sun' (*mapawelingu la kiri awangu, mata lodu*), and 'the one who comes to barter and sell' (*mamai palehu, mamai padangangu*). While the referent of the first expression is straightforward, that of the second is rather obscure. From what I was told and from the fact that it is conjoined with the first expression, however, it would appear to refer both to the newborn child itself and to a particular ancestor (though apparently not the apical ancestor of the clan) who accompanies the child and confers on it his or her name (see Section 3 below). What is 'bartered' and 'sold', then, was said to refer to 'the means of increase' (*paworu wàngu*), i.e., the new member of the clan.

A woman in labour must confess all transgressions and omissions, whether recent or long past, she may have committed. The husband should also make a confession prior to the birth. If this is not done, the delivery will be long and complicated. Understandably, the pain and anxiety of the moment induce the woman to reveal a great deal she might otherwise deny, as I myself had occasion to witness; and cases of incest and adultery are said usually to come to light at this time. Suitable ritual atonement for any offence is made afterwards.

The delivery is assisted by elderly women, usually two, who support the squatting woman. They are called the *mapatika*, 'those who kneel'. One, the *mangàri*, should be practised in the art of 'massage' (*ngàri*)¹⁸ and thus be able to induce the delivery by pressing on the abdomen if necessary. If difficulties arise, men may help to support the woman, but then only her husband or men related as *balu* (prospective spouse).¹⁹

The husband should be at home when his child is born. If he is away from the village, on his return his head-cloth and shouder-cloth, betel purse, and machete must be taken from him before he enters the house. Although I never witnessed this, it is clear from the description I was given that it is done suddenly and forcibly. Relieving him of these things is intended to prevent 'hot' and dangerous influences the man may bring with him from outside the village from entering the house and harming the child. Evidently, then, the speed is required to effect a definite separation between the inside and the outside.

The umbilical cord (*kaleki puhu*, 'navel stalk') is cut at a length of two finger joints from the child's body. This must be done with a sharpened piece of bamboo (*kadika* or *tamiangu*), as a metal knife would cause the wound to bleed profusely and thus kill the child.²⁰

Afterwards the cord, the placenta (*eri*, 'younger sibling', or *karia*, 'companion'), and the bamboo knife are placed in a conical rice steamer (*hawiti*), which is then tied to the rope suspended from the ceiling. Later, the father takes it outside the village and buries the contents beneath a tree, often one with aerial roots. The rice steamer is then bound with the rope and inserted at a height of about one metre in the branches or between the roots and the trunk. Were it placed too high so as to sway in the wind, the child would shiver and shake.²¹

The proper time of a person's birth is predetermined by God. If he is born too early or, as the Rindi say, 'if he has not yet reached the specified time (or month) of his birth' (*jàka ndedi na-toma na rehi* [or *wula*] *dedina*), then his birth is not 'mature' (*matua*), and it is thought he will suffer an early death. Stillbirths are explained in the same way. A child's birth is shown to be too early if its finger and toe nails, or its hair, are not 'black, dark' (*mitingu*). By contrast to the Kédang (Barnes 1974:145, 148), who interpret the colour of the nails in the same way, there is no ritual means to compensate for this, though in a legend I recorded concerning the premature birth of an Umalulu noble child, an entirely black buffalo was slaughtered 'to enable the child to reach its proper time of birth'. In this respect, then, black is evidently auspicious, while, by implication, white (or 'light', *bara*) is inauspicious. I noted that white matter in the infant's orifices is a bad omen. Whether prohibitions concerning other white things, including eggs (the shells of which are always 'white'), are related to the opposition, however, is far from certain. The reasons given for these suggest other associations; so it is not at all clear that their colour is a relevant attribute.²² Moreover, birthmarks (*hudangu*), which are 'black', are considered inauspicious, though they seem not to be taken as a sign of early birth; if a child with a birthmark is passed under the belly of a horse or buffalo, I was told, the mark will disappear after a month or so. I shall return to this colour opposition below.

A premature birth is also indicated if the child's eyes do not open after four days or if it does not cry immediately. In the latter case crying must be induced or else the infant will die. One may jangle bells, tap lightly on tin or a piece of areca sheath (*kakomba winu*) or, as I was once told, twist a puppy's ear to make it whine; too loud a noise would startle the child's soul and cause it to fly away. A child who does not cry right away is said to be 'tired, exhausted' (*njili*) and 'to have not been fanned by its creator' (*ndedi hailarunanya na mawuluya*). Times of transition are commonly marked with percussion (see Needham

1967:611). In Rindi, however, only the birth of a noble child is marked with the beating of gongs and drums.

The correct time of birth is not calculated by the stages of the moon or the tides, though the monthly variation in ebb and flood are thought to foretell the child's sex. Thus boys are expected to be born about *kalalu*, the two periods of neap tide, and girls at *mihi*, when the difference between ebb and flood is most noticeable. Some people also reckon this by the daily tides, in which case male and female births are anticipated at high and low tide respectively.²³

4. Naming and Other Rites

The word *tamu*, 'name', which is apparently a reflex of Austronesian **tamu*, 'guest', 'stranger' (Dempwolff 1938:30), also has the more specific sense of 'namesake'.²⁴ A child is always named after a deceased forbear. In Rindi the name is generally decided by way of a procedure called *mihi puhu*, 'drying up of the navel'. After the umbilical cord is cut, cotton is placed around the navel and betel and areca, masticated with lime and ginger, are applied to the wound. Names are then recited, and the one uttered just before the navel ceases to bleed is considered the child's correct name. In another procedure, followed by two clans in Rindi, the child is offered the breast. After each name is called out, two half coconut shells are clapped together, and the name mentioned just before the child begins to suck is thus determined to be its own name. By contrast to *mihi puhu*, this procedure, called *bera kokuru*, 'to split a coconut', takes place at the time of the rite *hàngguru* (see Section 6 below), which in this case should follow eight days after the birth (though it is often postponed for some weeks or even months).

The names recited must be those of persons of the father's and mother's clans in the second or higher ascending generations from the child.²⁵ This practice appears to be general in eastern Sumba (see On-vee 1973:77), and in Rindi, at least, is the only clear instance of regular cognatic inheritance. When the list is exhausted, the names are repeated. It is forbidden to mention or confer names of persons in the parents' genealogical level, for then the child would not thrive. Preferably it should receive the names of its father's or mother's own parents. There was some disagreement as to whether a child may take the same name as that of a still living grandparent, but some thought it inadvisable, and once I even heard that to do so might result in the elderly person's death.

Name-giving is called *dekangu tamu*, 'to determine the name (-sake)'. *Dekangu* is both 'to surmise, divine' and 'to predestine, determine the fate of'; it can also refer to setting and solving a riddle. The word is probably related to *dika*, which Kapita (1974) lists as 'to specify, determine, decide the fate of', and 'to create, bring into being'.²⁶ The derivative terms *madekangu* (the one who predestines, etc.) and *mapadikangu* (the one who confers being, etc.) are thus both used to refer to God. *Madekangu*, however, also denotes the forbear whose name the child takes,²⁷ his *umbu* (or *àpu*) *tamu*, 'namesake grandparent, ancestor'. In Rindi this ancestral figure is thought to be present in the house at the moment of birth; it is he who 'answers' (*hema*) when his name is called out, by way of the staunching of the blood. The procedure is thus conceived as a determination of which ancestor is present, or, one might even say, which ancestor the child is.

The relation of a child and his ancestral namesake is therefore particularly close. Thus, when I asked a person the name of a specific forbear, he would sometimes reply 'it is I', indicating that he bore the same name. A child is said to be the 'replacement' (*hilu*) of his deceased namesake, or in parallel form, 'the replacement of the title and the name, replacement of the form and the voice, replacement of the foundation and the presence' (*hilu ngara hilu tamu, hilu hada hilu manurui, hilu latangu pangiangu*). The idea is further expressed with the phrases 'the sprout that makes the change, the branch that replaces' (*kalunga mapahepangu, kahanga mapahilungu*). Whether this implies a total reincarnation, however, is doubtful, for it was usually denied that the child's soul (*hamangu*) is that of his namesake. Nevertheless, as noted, there did seem to be the idea that the soul comes into being when the child is named. In accordance with the senses of *dekangu* just listed, moreover, the conferring of a name by the forbear is thought to involve the determination of the child's fate; and it is expected that the child will in some ways resemble the person after whom he is named. For this reason, then, certain names (those of epileptics, lepers, witches, and women who died in childbed were mentioned as examples) should be avoided lest the child go the same way. The fact that a child constantly ails or grows slowly may be due to its name having been incorrectly determined. Onvlee (1973:78) says another name is then sought by offering the child the breast, while Wielenga (1912:209) mentions that someone plagued with misfortune may change his name. In Rindi, however, I was told a name might properly be cancelled only if, after the initial ceremony, the navel again begins to bleed.

These ideas, as well as the rules of naming, thus express an identification or equivalence of alternate generations and, accordingly, an opposition of adjacent generations. The principle is consistent, of course, with their cyclical representation of life and death. In this respect, too, the antipathy between a newborn child and a corpse may be better appreciated. In relation to the child, a newly deceased person can in some ways be seen to be comparable to the parental generation, since the ancestor or 'grandparent' whose name the child takes is supposed to be someone for whom the protracted funerary rites have been fully discharged.

After the name-giving ceremony (or sometimes just before), a rite called *wuangu uhu madekangu*, 'to offer food to the name-giver', is performed on the front verandah. However, while here *madekangu* also refers to the ancestral namesake, this rite is principally concerned with the 'false name-giver' (*makahala dekangu*), described as 'the one who comes from the green forest and the stone enclosure'. As noted, this expression refers to the spiritual forces of the wild (see Chapter VI). The Rindi believe that when a person is born such a spirit (or spirits) will attempt to bestow upon him another, inauspicious name and fate, which would result in his untimely demise. It should be recalled, then, that *dekangu* can also mean 'to curse'.²⁸ The rite thus aims to placate this spirit, and to request (of the beneficent forces at the edge of the house) that the child be afforded divine protection. In effect, then, it is a means of sealing the boundaries of the building. As usual, the offering consists of betel, areca, metal chips, rice, and a small chicken.

Afterwards, a cluster of cactus, sometimes enclosed with stakes, is placed on the ground beneath the birth chamber where the mother remains throughout her subsequent confinement. This is intended to prevent domesticated animals from lapping up the post-natal discharge and to ensure that witches and earth spirits do not partake of it, to the detriment of the mother and child. Beforehand a small offering of metal chips, betel, and areca is dropped onto the spot through the floor. This is dedicated to 'the ones who hold in the lap the foundation of the house' (see Chapter VI) and 'who hold in the palms the fluid of reproduction and fecundity' (*mandema wai woru, wai baba*). The phrases refer respectively to the spiritual presence at the centre of the house foundation and to the cactus itself. It is then requested that the woman's discharge, 'the fluid (which is) the excess of creation and division' (*wai rihi wulu rihi daii*), be retained so that it may eventually 'return to the belly of the father and be placed in the womb of the mother' (*pabelinya*

la kambu amana, ka na-li la kambu inana), i.e., so that the couple may continue to produce offspring.

A similar offering is then placed in the hearth near the delivery chamber, towards the right or left side of the house (i.e., to the woman's right or left side as she sits facing towards the back of the building) according to whether the child is male or female. This is for 'the one whose forehead is hot, whose hand is scorched, the wide face, the place of warming' (*na mambana kaba mata, na mamutungu karanggu lima, na mata kalàba, na ngia padarangu*), which denotes the hearth (or its spiritual aspect). It is thus requested that the fire not crackle and sputter, and that the warm water in which the infant is bathed not splash or boil over. The rite coincides with the beginning of the woman's period of confinement.

In the two rites just mentioned, the spirits of the cactus and the hearth are invited to accompany the priest to the right front section of the house (*kaheli bokulu*) to partake in the *baha kaheli* ('to wash the floor') ceremony. For this a red cockerel is offered to the clan ancestor and the child's namesake. As the offering is the last of the rites that take place just after the birth, 'washing the floor' evidently indicates a symbolic cleansing of the house. The occasion is also known as 'collapsing the mast' or, in parallel form, 'to collapse the mast, and roll up the sail' (*pàpa tandu lamanga, kulurungu liru*). The phrases thus provide a further illustration of the imagery, shown in the first rite concerned with delivery when the child is exhorted to be born, whereby the birth is represented to be like the arrival of the clan ancestor from overseas. The notion of 'collapsing the mast', therefore, may be understood as an expression of the child's permanent arrival in the mortal world and the desire that he not return to his previous state, here identified with the world of the ancestors.²⁹ The rite is thus primarily concerned with separation. Immediately afterwards, the rice steamer containing the umbilical cord and placenta is bound with the rope previously suspended from the ceiling and both are taken outside the village and disposed of in the manner described above.

As her first milk (the colostrum) is thought to be bitter (*paita*)³⁰ and therefore harmful to the child, a woman must express it four times before she may begin suckling. In order to promote the flow of her good milk, she should eat roasted maize. The infant is thus initially suckled by another woman (the *mapahuhu*, 'suckler') who has herself recently given birth. Though I never heard that she need be related in any particular way to the mother, the woman's own mother may not

provide the service. In this regard it is worth noting the statement of a young mother, who said that it was not good for a woman and her daughter to give birth at the same time. If this should happen, she claimed, a cooling ceremony must be performed in order to prevent one of the infants from dying; and the older woman should not hold (*lunggu*) her newborn grandchild, nor the daughter her infant sibling. These ideas evidently involve, then, a fear of confusion between adjacent generations and thus provide another expression of the opposition of the two genealogical levels, which, as noted just above, is a corollary of the principle of the equivalence of alternate generations.

5. Confinement

Confinement is called *padarangu*, 'to warm oneself'.³¹ During this time the woman must stay continuously in the delivery chamber with her back to the fire, thus maintaining the same position as during the delivery. This, then, is another indication that the period is conceived as an extension of the delivery. The fire is fuelled with long-burning wood, preferably ironwood (*kahembi*), as it must not flame but glow. It is here that the mother and child eat, sleep, and bathe.

Confinement lasts from parturition until the woman feels fully recuperated or 'light' (*halela*). I noted earlier that a pregnant woman is recommended to do certain things that will make her perspire, in order to render her body 'light'. Sweating, which is evidently one purpose of the period of warming, is also regarded as a means of relieving the body of illness, i.e., of lightening it; hence *halela*, 'light', generally expresses the state of being healthy or recovered.³² (It can also mean 'young'.) Similarly, serious and minor illnesses are contrasted as 'heavy' (*mbotu*) and 'light' (*halela*). The warming is also thought to promote the complete expulsion of the post-natal discharge and to ensure a sufficient supply of milk. It is thus deemed necessary in order that the child grow strong and 'fat' (*kambombu*),³³ and I was told the woman's body would become swollen were she not to remain long enough by the fire. The woman should sit on her buttocks, not squat, otherwise the child would not walk, while sleeping during the day would result in her milk drying up. There seem not to be any special dietary restrictions that apply during this time, other than those which extend until weaning; and the father was said not to be subject to any restrictions. In Rindi the length of confinement is left to the woman herself to decide. Onvlee (1973:80) estimates three to six months, but in my

experience it is often shorter than this. Although it was also said that the period should end when the child is able to sit, I doubt whether many women nowadays remain confined for this long.

Eight days after the delivery, by which time the shrivelled remnant of the navel cord should have fallen off, the mother interrupts her confinement to take her first bath at the river, just before sunrise. This is the first time she leaves the house after parturition. She is accompanied by a priest, who first makes a simple offering at the water's edge to request that the child benefit from the cool river water, that its growth be rapid and strong 'like the growth of the sugar cane and the banana' (*hama tumbu tibu kaluu*), and that dangerous influences – designated with the names of skin diseases and fevers – be floated away to the river mouth.³⁴ These dangerous influences are identified in particular with the woman's discharge, which, as it might contaminate her milk, is considered harmful to the child. It is apparent, then, that the rite is meant to coincide with the time when this should be completely expelled. As she enters the water, the woman casts small portions of betel and areca towards the upstream and downstream directions. Afterwards, she brings back to the house from the river a bottle filled with 'cool water' (*wai maringu*). Two simple rites are then performed before removing the cactus (from beneath the house) and the leaves used in washing the child. Each is exhorted to 'return to its trunk and stem' (*beli la pingi la polana*) and not to lose its particular efficacy, so that it may again be of use at future births. The cactus is simply thrown away outside the village, while the leaves are taken in an old basket and placed beneath a tree. Before leaving, the priest places a bamboo stick, called a 'spindle' (*kindi*), in the ash at the edge of the hearth against which the mother sits. If the child is male, the spindle is placed to her right, thus towards the male section of the house, and if female to her left. The priest then renders it 'cool' by sprinkling it with the water brought from the river, and places an offering of metal chips, betel, and areca in the hearth.

No one in Rindi was able to explain the significance of the spindle. The speech made on this occasion, however, specifies the object of placing it in the hearth to be to ensure that human reproductive capacity (or 'that which derives from the Base of the Sky and the Head of the Earth') will be 'continuous and unbroken' and will continue 'to ascend to the interior of the house and the middle of the floor' (*hei li la kuru uma, la padua kaheli*). The presence of the spindle is said further to ensure that the child will thrive. As I have remarked, the

plank on which the woman sits during childbirth and confinement is called the 'base of the spinning wheel'. In this light, then, the birth and development of children might be seen as analogous to the two consecutive stages (spinning and winding) in the production of thread, thread representing a series of births, which it is hoped will be 'continuous and unbroken'.³⁵ It is perhaps also significant, however, that the spindle is stuck in the hearth after the navel cord has fallen off, in which respect it might be construed as its replacement. In fact, the object was once referred to as the *kindi puhu*, 'navel spindle'. The two could thus be compared as things which bind the mother and child to the hearth. Appropriately, the spindle is removed when the woman's confinement is ended and the child is first bathed at the river.

After the spindle is placed in the hearth, a woman shaves off all the child's head hair, nowadays usually with a razor blade. Although I was told that it should be a woman from the father's clan's wife-takers who performs this task, this seems not to be insisted upon. The hair is later placed with the remnant of the navel cord in a tiny plaited leaf carton. If all were not fitted inside, it is said, the child would never be weaned.³⁶ The carton is then stored away in the house (though in no particular place) with those belonging to the older children. When an adult undergoes the rite *kikiru matua*, 'mature shaving', which is discussed in the next chapter, the hair is removed from the village, while if the person dies beforehand it is buried with the corpse.

The first hair is called *lunggi la kambu*, 'hair from the womb', or *lunggi kawau* (or *kawai*). *Kawau* is 'smelly', and so possibly refers to its previous contact with the womb and the mother's discharge. While shearing clearly effects a separation of the child from this previous environment, however, I never heard that the hair is harmful (like the discharge) or that it actually smells. In fact, the only explanation I was given assumed that the word was *kawai*, 'Ende'. It was then interpreted in accordance with the idea that the child, like the clan ancestor, hails from foreign lands, one of which is Ende on Flores.

After the hair is cut, threads are tied around the child's wrists and ankles. These are called 'supports (or boundaries) of the milk' (*hingga* [or *padira*] *wai huhu*) and are said to promote growth; somewhat more to the point, their increasing tightness indicates the child's rate of growth. Without the threads, I was told, the joints would not be properly articulated. Some said they should be black, others white; the former is perhaps more usual, though as was pointed out to me, white threads quickly become blackened with dirt. Significantly, the threads

are also referred to as *bibitu*, 'cords bound around the feet to prevent slipping while climbing', a concept discussed in Section 2 above, and are described as 'the means by which (the child's) spirit and soul ascend' (*pahei wàngu ndewa hamanguna*), which is to say, prosper and develop. This is one of several idioms that represent growth and development as an ascent. When the child is able to sit, the threads are replaced with strings of beads. For a boy, I was told, the beads should be replaced four times before he is weaned or able to walk, at which time they are removed for good. (Adult men, however, may wear beads around their wrists.) Girls, by contrast, continue to wear beads throughout their lives, except for the ones on the legs, which are removed at marriage. If these customs were not observed, the Rindi claimed, a child would never stop taking milk.

The rites marking the end of a mother's confinement, which thus take place a few months after those just described, are called *pamaringu aii*, 'to cool the hearth'. Before sunrise, the child is taken for its first bath in the river. Since this is the first time the infant is taken outside the house, it is apparently the equivalent of rites elsewhere in Indonesia that mark the child's first contact with the earth (see Duyvendak 1946:124-25). The priest makes a simple offering at the water's edge, similar to that which precedes a woman's first bath after parturition. One aim of the rite is expressed with the phrases 'to float away the membrane of (the child's) birth, the placenta of his growth, the itching disease, the red rash, the shivers and fever' (*pamilya na kayuba dedina, na kaliku tumbuna, na koha na wutu rara, na hura dinga na analalu*). This does not of course refer to the actual placenta, which by this time has long been discarded, but rather, it would appear, to the environment of birth – the house and the hearth – from which the child is now separated for the first time. In this respect, then, the house may be regarded as an extension of the womb; and because it is now something extraneous, the symbolic membrane is considered hot and hence potentially harmful to the child.³⁷ Returning to the house, the priest places a simple offering in the hearth, before removing the spindle and taking it to the right front corner of the house, where he then dedicates several fowls to the clan ancestor, the ancestral namesake, and to the spirits of the hearth and the yard altar. By removing the spindle, the hearth is 'cooled', i.e., returned to its normal use or, stated otherwise, returned from the religious to the temporal sphere. The compartment in which the woman passed her confinement is then taken down. Later, the spindle is inserted in the thatch at the eaves, at

the front or back of the house according to whether the child is male or female.

The Rindi generally estimate weaning to take place at about two years of age. The child, I was told, should be separated from the mother and taken to another house for eight days. Afterwards an offering is made to the clan ancestor to inform him that the child has been weaned.

6. *Hàngguru*

This is an appropriate place to mention the *hàngguru* ('to meet, receive a guest') ceremony, whereby the child is formally introduced to the clan ancestor and the more recently deceased forbears of his clan, who are then requested to afford him protection and blessing. Specifically, the rite is intended to ensure that the child retains his 'soul' (*hamangu*), so that he may lead a long and full life free of illness and misfortune. When speaking Indonesian, the Rindi often refer to *hàngguru* as *hari jadi*, with the sense of 'day of birth, becoming'. The time at which the rite should properly take place, however, is now unclear. Traditionally, I was told, it was held when the remnant of the navel cord had fallen off, thus at the time of the mother's first bath and the child's first haircut.³⁸ This agrees, then, both with Onvlee (1973:80), who says eight days after birth, and with the practice of those clans in Rindi which hold the ceremony in conjunction with name-giving, which in this case should also follow after eight days. Kapita (1976a:56-7), on the other hand, says *hàngguru* should take place after one year but before weaning, and that it coincides with the time the child begins to 'tread on the earth and bathe in the river'. Similarly, Wielenga (1909a:185) defines it as a rite held 'when the child first presents itself to the earth'. One possibility is that this marked disagreement reflects regional variation in the custom.

At present, however, the ceremony in Rindi is usually not held until well after the child is weaned; in fact, all the performances I attended or heard about involved children of about five or more years of age, some already in their teens. The reason always given for the delay was the rather expensive preparations. A large animal (a buffalo or pig) and a great many fowls must be slaughtered on behalf of the clan ancestor, the child's ancestral namesake, the recently deceased forbears of the father's and mother's natal clans, and all the spiritual entities involved in the birth (the spirits of the yard altar, the hearth, the cactus, and so

on). Since the ceremony also concerns the ground on which fell the mother's discharge, it should be performed in the house and village where the birth took place. If this is not possible, a rite is performed at the yard altar on the evening before the ceremony to summon the spirit of this place. At this time, also, and continuing throughout the following day and into the next evening, there is usually dancing, singing, and the playing of gongs. It is thus something of a festive occasion. All members of the local clan and the father's closest affines should attend.⁹⁹ *Hàngguru* is thus a rite of incorporation by means of which the child is introduced to a community that includes both living and dead members.

7. Summary of Major Themes

It is now useful to consider the various rites that accompany a birth in terms of van Gennep's (1960) scheme of separation, transition, and incorporation. Viewed chronologically, the rites can be seen to form three series. The first comprises those performed just after parturition. These mostly express the theme of separation, though the naming ceremony, which usually accompanies the cutting of the umbilical cord, clearly entails incorporation, even though it coincides with an act of disconnexion. *Wuangu uhu madekangu* also expresses separation, as it serves to seal the boundaries of the house; and like the rites that concern the hearth and the cactus, it is connected with the beginning of a period of transition, i.e., the confinement of the mother and child. But although the mother begins to warm herself immediately after the birth, it is not clear whether this is to be considered the formal commencement of confinement; for this period could be interpreted as beginning eight days later, when the spindle is stuck in the hearth. The eight day interval between the first and second series of rites thus suggests a completed transition of another sort, as it coincides with the time thought necessary completely to expel the post-natal discharge. The final rite in the first series again concerns a separation, specifically that of the child from 'the world preceding human society' (van Gennep 1960:52). The fact that an infant is initially suckled by another woman, and thus separated from the mother, might also be viewed in this light (see van Gennep *ibid.*:50).

The second series of rites, comprising the mother's first bath, the removal of the cactus and the leaves, the cutting of the child's hair, and the removal of the remnant of the navel cord, similarly marks a

stage in the gradual separation of the mother and child from the environment of birth. As I have just noted, some of these rites also appear formally to initiate or, perhaps better stated, affirm the period of confinement. The placing of the spindle in the hearth can thus be seen as an act which, symbolically, further binds the woman and her infant to this spot. If, as the evidence indicates, the *hângguru* ceremony also formerly took place at this stage, however, the theme of incorporation would clearly be present as well. It is worth recalling, then, that some clans do not perform the name-giving ceremony until this time.

For the child, the third set of rites, *pamaringu aii*, also concerns separation, in particular a separation from the hearth and house. Yet, as an introduction to the outside world, the infant's first bath at the river can also be viewed as an incorporation. For the mother, too, this stage represents a separation marking the end of a period of transition and hence a return to her normal condition.

While the themes of separation, transition, and incorporation are expressed in various of the rites, therefore, they do not quite coincide with a chronological sequence of stages, either in respect of the entirety of the performances or within each of the three distinguishable series considered separately. Clearly, however, the commonest theme is separation; so, in general, birth can be described as a cumulative process of disattachment of the child from its previous environment. Since this environment is in part identifiable with the womb, the process thus involves a gradual redefinition of the relation of the child and the mother. A further transformation of this relationship occurs at the initiation ceremony for a boy and at marriage for a girl.

CHAPTER VIII

AGE AND THE LIFE CYCLE

Ageing is viewed in Rindi as a gradual development of the body and personality; and is articulated by a series of rites and symbolic usages and divided into several named stages. Traditionally, a person's age was never recorded in years. Even today most people have only a very approximate idea of how old they are, and for many older persons an age stated as a number of years (*ndaungu*) is meaningless. When necessary, age can be reckoned in relation to well-known events, just as the time at which an event occurred is often referred to the level of maturity of a known person at the time. Accordingly, persons with some education can often state their year of birth and yet not readily know their chronological age. Relative age, in contrast, is always known among persons who have grown up together.

1. Age Classes

Adults and children are distinguished as *tau matua*, 'mature, developed people', and *anakeda*. *Matua* is also used relatively, to denote any significant stage in an individual's development. In fact, in the sense of 'maturity', it is the closest one can come in eastern Sumbanese to the English word 'age'. Of a child who can sit upright, for example, it is said 'his sitting is mature' (*na matuaka na mandapuna*), and a child who can generally look after himself is described as a 'mature child' (*anakeda matua*). With regard to fruit, *matua* is '(almost) ripe'. It also means 'respected, honoured, revered' and 'respectable'.¹ This suggests, then, not only that an adult is respected, but that a person is held in higher regard the older he is. I shall return to these ideas presently.

Children are broadly distinguished as 'small' and 'large' (*anakeda kudu*, *anakeda bokulu*). The terms are by their nature vague. The latter, though, is usually applied to youngsters above the age of 7 or 8 and is more or less synonymous with *anakeda matua*. Until it is weaned, a baby

is called *ana rara*, 'red child', a reference to its complexion. I recorded some 14 expressions that denote significant stages in a child's development during babyhood, but since all are straightforwardly descriptive of the gradual acquisition of physical skills – there are no metaphorical references to plant growth, for example – they need not be listed here. It is worthwhile, however, to note the use of *mandungu*, 'firm', 'secure', 'settled', to qualify an infant's mastery of sitting (*mandapu mandungu*, 'to sit securely') and walking (*pangga mandungu*, 'to walk firmly'). The word (or the synonymous *undungu*) is also used to indicate a boy's ability to ride a horse, and a child's ability to dress by himself. Similarly, a person married with a family is said to be *mandungu* ('settled'). We should also recall the name of the rite *pamandungu pelungu*, described in the previous chapter. These usages thus indicate that in Rindi development is viewed as a gradual process of 'firming up'.

After babyhood a child's development is indicated with reference to the time he is first given a lower garment (which at first he is inclined to drag along the ground rather than wear), and when he is able to put it on (and keep it on) by himself. Nowadays, children usually go naked until the age of about four, while traditionally they did so for rather longer. After early childhood, the criteria by which growing up is observed begin to diverge for boys and girls. It is then noted when a boy can ride a horse and accompany his father on journeys to obtain foodstuffs (*mandara*). From a comparable age until marriage, girls, on the other hand, are divided into age classes indicated by characteristic hairstyles, which are described just below.

Adolescents are called 'new males and females' (*bidi mini*, *bidi kawini*), which suggests that at this age youngsters come to acquire a fuller sexual identity. The general term *bidi tau*, 'new person', however, usually refers to a married or unmarried young adult, until about the age of 35 or 40. By contrast, *bidi mini* and *bidi kawini*, as I was told, cannot properly be applied to married persons. Several other expressions distinguish age classes among adults (*tau matua*). Middle-aged persons are called *padua tau*, which seems literally to mean 'middle of the person, body'. The condition is indicated mainly by physical signs, including the appearance of all four wisdom teeth, and 'the gradual retreat of the flesh', i.e., lines, wrinkles and gauntness. Men of advanced age, perhaps 60 or over, are called *ama bokulu*, 'big, great father'. Though the term may be glossed as 'elder', it is further used with the specific sense of 'ritual functionary' and 'clan headman'; thus it can be applied to somewhat younger men. Nevertheless, ritual func-

tionaries, especially, are typically elderly, and if a clan headman (see Chapter XI) is young, it is then sometimes said that the clan has no *ama bokulu*. The female equivalent, and complementary term, is *ina matua*, 'mature mother'; but, interestingly, while *ama bokulu*, as a reference to age status, invariably denotes an elderly man, *ina matua* may be applied to women who are a good deal younger. Thus, I was told, a woman who has given birth to a number of children (four, by one reckoning) is already a 'mature mother', even though she may still be in her thirties. The disparity suggests, then, that after marrying and bearing children a woman has realized her full social potential, while a man, by contrast, still has some years to mature, particularly with regard to his involvement in ritual life. Very old people are called *makaweda*, a category which overlaps considerably with *ama bokulu* and *ina matua*.² The age status is commonly defined with reference to the loss of the teeth and, accordingly, the practice of crushing betel and areca with a mortar and pestle.

2. *The Hair*

How the hair is worn is an important indicator of age status in Rindi (see Plates 2a to 3b). As noted, an infant's hair is first shorn eight days after birth. The head is then kept completely bare until the child can sit upright, which is supposed to coincide with the end of the mother's confinement. I was told that the hair will need to be shorn four times during this period, an idea which thus suggests yet another context in which this and other even numbers signify completeness. When it is later cut again, a small patch, called 'chicken feces' (*tai manu*), is left just above the temple, on the right side of the head for a boy and on the left for a girl. Once the hair at the front has again grown, it is then cut leaving only a forelock at the centre of the head about the fontanelle, which falls over the forehead; this is called the *lunggi taka*, a term I shall discuss further below.

The style is maintained until after the child is weaned. Later the hair is left to grow out and then cut in the style called *hili wuku*, which involves shaving the head to well above the ears leaving the forelock (*lunggi taka*) at the front and longer hair at the back and sides. The hair at the crown is cut short and among girls is combed back to give a spiky appearance; with boys it is left flat. Following Kapita (1974), *hili wuku* means 'substitute (see *hili, hilu*) of the bun, top knot', the latter terms referring to the characteristic hairstyle of adult men and women.

The name thus focuses on the hair at the top of the head, or the 'covering of the crown (of hair)' (*pandàbi kawuluru*) as it is called.

While the *hili wuku* style is still common among little girls and the norm among female adolescents, boys now wear their hair in the short western fashion. In part this seems to be due to the ban imposed on the style by Christian schoolteachers, since boys attend school more often and longer than girls. But while girls who leave school in their early teens or younger usually revert to the traditional style, boys of the same age do not. The reason, I suggest, is that the hairstyle indicates unmarried status, and this is more importantly signified for females than for males. Indeed, as the term can refer as much to an age class as to the hairstyle, *hili wuku* is often used in Rindi to denote a sexually mature, unmarried girl. Girls are then further distinguished as 'small' and 'big' *hili wuku* (*hili wuku kudu*, *hili wuku bokulu*). The second term applies about the onset of puberty. Although the hairstyle remains basically the same, after this time the hair at the sides is allowed to grow down to just above the ears and is left longer at the back, whereas earlier it is shaven much higher, to about the temples. A nubile girl, especially one whose marriage is close at hand, is called *ana karia*.³ At this time the forelock is cut to the hairline, and thereafter the hair is left to grow.

Adults wear their hair long. The phrases 'mature of body, long of hair' (*matua tau*, *malai lunggi*), therefore, form a fixed expression denoting adulthood, in particular the age at which a person is ready to marry.⁴ Although long hair thus connotes marriage, adult women leave it to grow even while they are still single, as it would be thought ridiculous for a mature woman (past her mid-twenties, say) to retain the unmarried girl's hairstyle. A man's hair is worn in a high top knot (*kawuku*) at the crown, while a woman's is wound more loosely in a flat bun (*kawuku tera*),⁵ which lies further to the back. In accordance with the general distinction of the above and the below as masculine and feminine, these arrangements are described as 'up' (*dita*) and 'down' (*wawa*) respectively.⁶ Traditionally, adults seem rarely to have cut their hair, but since Indonesian independence short hair cuts have become more common among men, especially those of middle age or younger. Among older men, on the other hand, long hair is still usual. Again, the traditional style has not changed at all for women.

The most important difference between adults' and children's hairstyles is that children keep the forehead covered whereas adults do not. It is relevant, then, that the Rindi regard the forehead as a 'sign of

shame' (*tanda makia*),⁷ hence the uncovered forehead of an adult is said to indicate that he 'knows shame'. This implies both that he has knowledge and experience of sexuality and that he is sufficiently mature to behave morally; thus a responsible adult is described as *matua kaba mata*, 'having a mature forehead'. A child, on the other hand, is without 'shame', both in respect of his presumed innocence of adult matters (especially sex) and his supposed incapacity for responsible, moral behaviour. For this reason, breaches of propriety by children often pass without comment or correction, and such behaviour, which is simply ascribed to their immaturity, is expected to change, as it were naturally, once they grow older.⁸ Following Onvlee (1973:27), therefore, it may be said that children are not taken seriously in Rindi, and that as they have no say in adult society, they are not fully subject to its rules. It is significant, then, that *taka*, which term describes a youngster's forelock (*lunggi taka*; *lunggi* is 'head hair'), is listed by Kapita (1974) as 'screen, partition (plus verbal senses)' and 'to forbid, prevent, restrain'. A child's forelock, therefore, might be taken to signify that he is excluded or shut off from the adult world and, in a sense, is restricted from engaging in activities proper to adults.⁹

As I shall show with reference to the rite *kikiru matua*, the long hair of adults connotes sexuality and fecundity, and with regard to the top knot or bun, specifically restrained or ordered sexuality. Thus adults wear their hair down only in informal, domestic situations, when in or around the house. A child's hairstyle, therefore, might further be said to express normative asexuality in that the hair, especially that at the crown, is cut short. I suggest, then, that Rindi customs show sexuality to be controlled in two ways: by cutting the hair, which signifies an absolute restriction, and by binding it, which indicates sexual restraint (see Leach 1967:90). It is possibly of some significance in this regard that a woman's hair is more loosely bound than a man's. Otherwise, long loose hair appears to be linked with extraordinary spiritual power; thus witches and the dead are said to wear their hair loose, and in the former case, over their foreheads.

3. *Puru la Wai: Initiation*

For adolescent males the passage to adulthood is marked with what for want of a better word may be called a circumcision ceremony. This is carried out once a youth has reached puberty or, at any rate, before marriage. In the performance I was privileged to attend, however, two

of the 27 novitiates seemed a good deal younger than this, while another three were already married. The rite is said to promote fertility in marriage.¹⁰ It is held in Rindi once in a number of years, whenever a young nobleman of the highest rank reaches the appropriate age; but youths of all classes and clans in the domain are summoned to participate. The ceremony takes place in the early part of the dry season, about July or August.

There is space here only to summarize the main points of the rite. The operation itself is called *waku* or *kàri*, which both mean 'to cut, scratch, incise'. The youths are confined¹¹ for a period of four or, preferably, eight days in a rectangular hut, the 'circumcision house' (*uma waku*), which is built at a secluded spot in a banana grove near the river. It is from this location that the name of the ceremony, *puru la wai*, 'to go down to the river', derives. Another euphemism is 'to guard the maize' (*dai wataru*). The single entrance to the hut, at the centre of one of the longer sides, should face towards the river and the rising sun. For each initiate a banana trunk is cut and placed inside the hut to mark out their sleeping places. There must be an even number of youths; so if there is not (as in the performance I witnessed), an additional trunk is cut to serve as the 'partner, counterpart' (*papa*) of the extra boy. Another trunk, which the boys straddle during the circumcision, is placed in the middle of the hut perpendicular to the doorway. Just outside, to the right as one leaves, is placed a flat stone, the 'circumcision altar' (*katoda waku* or *kàri*), at which offerings are made at various times during the initiation period.

The actual circumcision proceeds after the novitiates have spent one night in the hut. On the evening before, each youth must reveal to the officiating priest the details of any previous sexual experience he has had, so that an appropriate expiation can later be made. Though, strictly speaking, a boy should not have indulged in sex before he undergoes the rite, some hold that if an initiate already has wide sexual experience the operation should only be simulated. In such cases, I was told, an incision may be made on the right knee instead of on the penis, or alternatively the end of his loin-cloth might be torn.

On the following morning, at the rising of the morning star, the youths bathe in the river. On re-entering the hut, one by one they straddle the banana trunk in the centre, facing towards the door. The priest then sits on the ground facing the youth and places his penis so that it rests on an elliptical piece of coconut shell stuck into the soft trunk. The shell (*kaba kàri*), which was said to represent the female

genitalia, is considered the feminine counterpart of the masculine metal knife (*kahidi hotu*).¹² The priest first asks the youth 'how many pigs have you speared?', i.e., with how many women have you had intercourse. He replies, giving only the number. If he is not strictly honest, later his wound will not heal. A slight incision (perhaps 5 mm long) is then made on the foreskin. Although it may bleed a little, it seemed not to occasion much distress. If the initiates are of an uneven number, the priest also makes a scratch on the additional banana trunk that serves as the 'partner' of the extra boy. The youths then return to their sleeping places. Whenever they lie down during the course of their seclusion, they must suspend their loin-cloths with cords hung from the ceiling, in order to prevent contact with the wound, which otherwise would swell. Powdered chalkstone mixed with water is placed on the wound to promote healing. Afterwards, metal chips, betel and areca, numerous fowls, and a pig are dedicated at the altar. The offering is intended in part as an atonement for any sexuality, especially that of an illicit nature, in which the initiates may have indulged. The rite is addressed primarily to 'the lord and lady at the river bank and the water's edge', the entities also addressed in rites that precede a woman's first bath after parturition and an infant's very first bath at the river. This, then, is another indication of a general link between the river, or the river's edge, and transition rites in Rindi.

Throughout the initiation period, the youths, supervised by adult men, exercise the privilege of visiting each village to request, or take forcibly if refused, livestock.¹³ Only buffaloes are exempted.¹⁴ The animals serve as food for the boys during their confinement. They thus eat extremely well. The priest makes an offering at the altar each day before they leave and again when they return.

On the final day, at the rising of the morning star, the initiates again go to the river to bathe, taking with them the banana trunk on which they sat during circumcision and the piece of coconut shell. While in the water, they jostle over the trunk, throwing and pushing it about and attempting to straddle it. This is done, I was told, so that anything that is 'hot' will be transferred from their bodies to the trunk and hence carried away with it downstream. For the same reason the youths must wash out their loin-cloths. On their return, they build a fire of dried coconut boughs behind the hut to warm themselves and to ensure that their genitals are completely dried. This might be compared, then, to a mother's warming herself after childbirth. After the initiates re-enter the hut, the priest makes a final offering at the altar, in order to invoke

the deity of the cool water (*wai maringu m̀anjaku*, see Chapter V), thus further to neutralize what is hot and to cool the initiates. A pig and several chickens are then slaughtered. The youths take their meal inside the hut, where on the occasion I witnessed, they were served by men of noble rank.¹⁵ Afterwards, they leave the hut and, seated on the ground, are given advice concerning their responsibilities as adults by the priest and other mature men present. The boys then take all the banana trunks and the cords used to suspend their loin-cloths and dump them in the river. The hut and altar are disassembled, and the youths return home.

The ceremony thus clearly involves an act of separation, a transitional phase, and a rite of incorporation. Seclusion is more specifically intended to isolate the youths from the female sex than from the community as a whole. Thus, while adult men may approach the hut, the only females who may come anywhere near it are a few women past child-bearing age who do the cooking on an outdoor hearth some distance away. Of the numerous prohibitions that apply to the initiates, moreover, many concern the female sex: they may not speak the name of any woman or even use the word 'woman', and references to sexual intercourse, when necessary, must be expressed in terms of spearing pigs.¹⁶ A breach of these restrictions causes the genitals to swell; and a youth who suffers from this must remain in the hut until he is fully recovered. Seclusion thus serves to separate the initiates from the asexual world of childhood as a prelude to their incorporation into the adult community, where their relation with women will be radically altered (see van Gennep 1960:67).

At the beginning and at the end of the transitional period the initiates bathe in the river; they do not do so in the interval. As in rites concerned with birth, therefore, bathing, which is seen as a means of expelling what is hot and obtaining coolness, here coincides with a passage from one ritual status to another. Although it was said to refer specifically to traces of forbidden sex, the 'heat' which is thus removed before the ceremony is ended is more clearly identifiable with things with which the initiates have been in close contact during the marginal state of seclusion. In a sense, then, it is the transitional period itself which is hot; so the cooling that takes place during the final rite might be interpreted as an act of returning the initiates to a normal (or secular) condition. As in other instances of ritual transition, therefore, *pamaringu*, 'to cool', might here be glossed as 'to make secular'. As the wound, too, is regarded as something hot, the period of transition is formally coincident with the time it takes to heal.

As I have shown, the banana tree is a particularly prominent symbol in initiation. Recalling that a banana trunk serves to render the number of youths even, one possibility, then, is that it represents the penis and the male person. Thus casting the trunks into the river at the end of the ceremony might be interpreted as a symbolic removal of the former immature identities of the initiates themselves. Perhaps a more significant connexion, however, is found in the fact that among plants the banana is considered cool, i.e., conducive to prosperity and beyond the reach of harmful influences (see Wielenga 1910b:131).¹⁷ Thus I was told that the knife and coconut shell used in circumcision must afterwards remain stuck in the banana trunk 'so that they will be cooled'.¹⁸ The Rindi refer the coolness of the banana in part to the cool moistness of its trunk. Sugar cane (*tibu*), which in ritual speech is the complement of the banana, exhibits the same property; and both plants are further noted for their rapid growth.¹⁹ I mentioned that in birth rites it is requested that the child 'grow like the sugar cane and banana'. With regard to both of these features, therefore, the two plants seem to be generally associated with vitality.²⁰ The express need for coolness during the initiation ceremony might also be taken to indicate that the initiates during this time are especially vulnerable to harmful forces. But I never heard it exactly stated that this was so.

The Rindi say that circumcision is the male equivalent of the onset of menses in women, and they describe both as *tanda matua*, 'signs of maturity'. A girl's first period, however, is not marked with a rite, and there is no initiation ceremony for women. It might therefore be said that what is signified by an event that is, in a sense, natural for a female is brought about culturally for a male.

4. *Other Usages Associated with Maturity*

Traditionally, in order to be considered fully adult a person had to be tattooed and have his teeth filed. Until quite recently, teeth filing, called *rondangu*, was a universal practice in Rindi, but it is nowadays rarely done.²¹ Among young people, however, it has become common occasionally to polish or grind (*deli*) the teeth with a stone or file to render them even. In contrast, *rondangu* entails the single operation of cutting the teeth, and it is associated with blackening them, whereas simple grinding is not. Some older people spoke disapprovingly of teeth grinding (*deli*), describing it as a foreign custom followed only for cosmetic reasons. By implication, then, *rondangu* has other purposes.

It is said that if the teeth are cut before a person is fully grown they might grow out again. Men should thus have it done after circumcision but before marriage, and women once they are nubile. If it is not done before marriage, I was told, it should not be carried out afterwards. Any man with sufficient skill may perform the operation. First, the six top front teeth (including the canines) are cut with a sort of file (*korinda*), and, perhaps a month or more later, the same is done with the bottom six. About 5 mm of the tooth is removed.²² An offering is then made to the clan ancestor to request that the teeth and gums not bleed profusely.

Apart from long teeth being considered unattractive, the reasons given for teeth filing were: that it stops them from becoming long and loose in old age; prevents damage to the lips and tongue should one suffer a fall; allows betel and areca to be chewed more easily; and that it strengthens the gums. This last benefit is also attributed to betel chewing itself, and the two practices are linked in other ways as well. Thus it is held that after the teeth are cut, betel and areca must be chewed continuously to keep them from rotting and smelling; hence it is at this stage of his life that a person should take up the practice of betel chewing in earnest. Chewing betel, moreover, is one means by which the teeth are made black. Another method is chewing the crushed leaves of the plant *rii kamiti* (see *mittingu*, 'black'; *kamiti* also refers to the temples), which is also used to blacken wooden and coconut shell vessels. But while in the latter instance blackening is said to prevent rot, persons I asked did not think this was relevant to the teeth. The teeth are first blackened in this way before filing, as this is supposed to ensure that they will not be slippery and difficult to cut. Thereafter the colour is retained by constant betel chewing and the occasional further use of *rii kamiti*.

The only reason given for blackening the teeth was that black teeth are attractive. It seems rather more pertinent, however, that witches and malevolent forces associated with the wild have long and white teeth, as of course do children; so both teeth filing and blackening serve to indicate a civilized, moral condition from which children, witches, and wild spirits are excluded. As with regard to the association of black (or dark) with mature births, in this case the colour, in contrast to white (or light), further suggests the idea of completeness or fulfilment. We might also recall, then, that pregnancy is announced with the phrase 'it is black (dark) at the Head of the Earth'. This seems an appropriate place to point out that in other contexts black seems, more

specifically, to express disconnexion, while white, accordingly, is suggestive of connexion.²³ Thus, whereas black is a suitable colour for cloths given at a funeral, white is not, and if only a white cloth is available for this purpose, I was told, it should be torn at one end. As regards marriage prestations, on the other hand, the reverse is the case, and it was said that were a black cloth given at a marriage, the affinal connexion would be broken for good. In other contexts, however, the significance of black or white derives from the opposition of each to red. The symbolic uses of red are discussed in the next chapter.

Tattooing (*katàtu*) is universal in Rindi, and everyone should have at least one tattoo. The designs, placed on the lower arm or, less commonly, on the upper arm or foreleg, include rampant lions, deer, horses, cockatoo, chickens, shrimps, fish, scorpions, and pythons, in fact nearly all the motifs used to decorate textiles. Names or initials are nowadays quite common. As a sort of minimal requirement, a simple cross (*kapala malungu*) may be tattooed on the lower arm. Most people are first tattooed in their mid-teens; but I was unable to ascertain whether it should be done before or after circumcision or teeth filing. Anyone accomplished in the art may perform the operation, which involves rubbing a solution of fine black soot and sugar cane juice into indentations made in the skin with lemon thorns. Apart from its cosmetic value, tattooing is said to be necessary so that a person, after his decease, may obtain fire in the land of the dead. If he has no tattoo, the dead will refuse his request.²⁴ I never heard, though, that an untattooed person would be refused entry into the land of the dead, as Kapita (1976a:59) states. Nevertheless, both ideas clearly suggest tattooing to be a preparation for death as much as for adulthood.²⁵

Since I have shown the habitual chewing of betel and areca (with lime) to be another practice entailed by adult status, there are several further points concerning the custom that should be noted in this connexion.²⁶ As I remarked previously, offering and receiving chewing ingredients is considered essential to sociability and is a requisite of all intercourse beyond the immediate domestic sphere in Rindi. Furthermore, all offerings to spirits and most prestations made to affines include a portion of betel and areca. That children should not chew betel is therefore clearly related to the fact that these usages pertain exclusively to adults. Although little is actually done to discourage it, the occasional partaking of betel and areca by children is disparagingly called *pahàpa panjalangu*, 'to chew inconstantly' or 'in error' (see *njala*, 'fault, mistake, etc.'), a phrase which seems to involve the idea that

it is not only inappropriate but pointless and meaningless as well. A youth, therefore, should not begin to chew regularly before circumcision, as this would cause the wound to sting, and a girl not before she is physically mature. It is at this time, then, that a young man is given a betel bag (*kalumbutu*), and a young woman her first betel basket (*kâpu*). These should be carried on the person whenever one leaves the village for any length of time.²⁷ An adult man, and a woman on the most formal occasions, should also carry a machete or knife (*kabela* for a man, *kahidi yutu* for a woman), which the Rindi regard as the complement of the betel container. Without these two items a person away from home is considered improperly dressed.

5. *Kikiru Matua*

The last of the life cycle rites before a person's death is *kikiru matua*, 'mature shearing'.²⁸ While I never saw it performed, it seems important enough, nevertheless, to give some account of what I was told about it. The rite forms part of a clan's first fruits ceremony (*ngangu uhu*, 'to eat rice') and may involve one or more members of the clan, of both sexes, simultaneously. Typically, it seems, a person undergoes *kikiru matua* as a young married adult, though older and unmarried persons may participate as well. The cutting of the hair, which takes place at the front of the clan's oldest, ancestral house, should be done, I was told, by persons belonging to a wife-taking group.²⁹ After the hair is oiled and combed, a man first cuts a short length from the front of the head, and then a woman cuts a similar amount from the back. The hair at the centre of the head, it is important to note, is not cut. This is then followed by a major rite of offering. On the morning of the following day the newly shorn locks, together with the hair from the principals' first tonsures and their navel cords, are taken from the village and inserted in the loose bast of a banana trunk, on the side that faces the rising sun. The practice is said to have the effect of cooling both the hair at the crown and the soul (*hamangu*), so that the person might enjoy good health, be prolific, and lead a long life.³⁰

In order to understand this rite it is necessary to consider further the spiritual significance of the hair. Although the soul is connected in various ways with the hair in Rindi, as the above ideas show it is especially linked with the hair at the crown. This might be ascribed to the apparent fact that the crown of hair constitutes a focus or the point of origin of the hair. The crown is also closely identified with the

fontanelle (*lawungu*); and the association of both with the soul, especially the idea that it is from here that the soul enters and leaves the body (see Kruyt n.d.:17; 1906:76), is common in Indonesia.³¹ In Rindi the crown of hair is called the *kawuluru*, 'swirl', or, specifically, the *kawuluru katiku*, 'head swirl'. Although these might not always be visible, the Rindi say a person may have other *kawuluru* besides the one at the crown, e.g., in the centre of the back and on the hands and feet; and the number a man has is supposed to foretell how many wives he will take.³² This, then, is one idea that clearly links the *kawuluru* with fortune or destiny. The connexion, as well as that between the crown of hair and the soul, is further expressed in the idioms *kàba kawuluru*, 'having a weak crown of hair', and *hàmù kawuluru*, 'having a good crown', which are synonymous with *kàba hamangu*, 'having a weak soul', and *hàmù ndewa* (or *ura*), 'having (a) good fortune (or spirit, soul)', respectively.

In Rindi, the crown of hair is also linked with the top knot (*kawuku*) or bun (*kawuku tera*), which, of course, covers the crown, and both are associated with prosperity and fertility. In this latter regard, the hair at the crown was said to be comparable to the pubic hair (*wulu*),³³ while the hair knot was spoken of as the 'trunk, source' (*pingi*) of reproductive power, an idea which clearly links it with the spiritual powers of *ndewa-pahomba* (see Chapter IV). It may be recalled, therefore, that *kawuku*, 'knot', is also the name of the peak of a house, which is the place of the ancestral spirit. Another sense of the word is 'descendant' as in *nda ningù kawukuna*, 'he has no descendants', a phrase which describes a childless person. Since *kawuku* is also a general word for 'joint' or 'knot', the main idea here seems to be that such a person, after his decease, would have no direct link with the living.³⁴ With regard to both the top knot and the house peak, then, this shows one respect in which the centre of the head, like other places of spirit (see Chapter VI), may be associated with articulation and transition. We should also recall the connexion between 'heads' and 'sources' mentioned in Chapter III.

It is thus consistent with the significance of an adult's head and hair that *kikiru matua* forms part of the *ngangu uhu* ceremony, an undertaking which has the aim of ensuring the fertility and prosperity not only of humans but of animals and plants as well. The focus of the ceremony is the eating of the separately harvested and processed first rice of the year, the 'morning star rice' (*uhu marai romu*),³⁵ which is consecrated to the clan ancestor. In ritual speech, this portion of rice is

called 'the knot of growth and birth, the knot of prolificity and fecundity' (*kawuku tumbu kawuku dedi, kawuku woru kawuku bàba*).³⁶ Not surprisingly, these phrases were said also to refer to an adult's hair knot (*kawuku*). Cutting the hair at the front and back of the head and placing it outside the village at *kikiru matua*, moreover, was said to be comparable to the rite *paluhu kalàmba*, at which the chaff is removed from the village after the harvest. This is done so that the rice will be replenished in the following year. Similarly, a major aim of *kikiru matua* is to facilitate the birth of future generations. By analogy, therefore, the hair that is cut and that at the crown, which is not cut, appear to be symbolically equivalent to the empty chaff and the harvested rice respectively.

As noted, in ritual language the phrase *kikiru matua* is conjoined with *hàngguru matua*, which term by itself denotes a child's formal introduction to the ancestors and the living members of his clan. It should also be recalled that traditionally the *hàngguru* ceremony seems to have been held at the time of the child's first haircut. That the two rites are conceived in apposition, and, in parallel speech, designated in the same way, therefore, may be attributed to the fact that each initiates one of the two major stages in an individual's life, namely childhood and adulthood. It is in accordance with this that the expression *kikiru matua, hàngguru matua*, here referring, as I was told, specifically to *hàngguru*, is further applied in Rindi to the renewal rites (*pamangu katoda*) held at the various altars prior to the rice harvest. As *kikiru matua* is compared to the ritual removal of the chaff (*paluhu kalàmba*), this then suggests that in this context immature, unharvested rice and harvested rice are represented as analogous to children and adults respectively.

6. Age and Authority

As I remarked at the beginning of the chapter, the word *matua* implies respect; and greater age, whether relative or absolute, does indeed command respect in Rindi.³⁷ The extent to which age is associated with authority, however, is complicated in this society by the factors of class standing and lineal seniority. Class in particular usually carries greater weight than does age; so in the normal course of affairs an older person of lower rank must defer to a higher ranking younger person. But in this regard a distinction needs to be drawn between different types of authority. As illustrated previously, age and spiri-

tuality are associated in numerous areas of Rindi thought, and as I shall elaborate in Chapter XI, authority founded on age mainly concerns spiritual or religious matters. Class, on the other hand, is a matter of worldly power.

This is not to claim, however, that age does not entail authority in temporal concerns as well. Indeed, provided they are of the same rank and equal with regard to lineal seniority, a younger man, e.g., a younger full sibling, is in every respect formally subordinate to an older one.³⁸ In general terms, therefore, the most influential members of society are the elders, the 'great fathers and mature mothers' (*ama bokulu, ina matua*) mentioned in Section 1 above. In part, the elders' authority derives from their experience and superior knowledge of customary matters, on which the welfare of the community is seen ultimately to depend. It is thus the male elders who serve as priests (*ama bokulu mahamayangu*). Ritual speakers (*wunangu*), as well, are mostly older men, though as is consistent with the association of age with spiritual authority in particular, this task, which involves mediation between social groups (mostly affines) rather than between man and divinity, is often carried out by somewhat younger men. Priests, on the other hand, are invariably past middle age and usually elderly. These two positions, it should be noted, are acquired solely on the basis of knowledge and age (which is a precondition of such knowledge), and though the requisite ability is thought often to be inherited, heredity is not formally a restricting factor. In accordance with the idea that illness and early death are divine retribution for transgression or omission, however, advanced age in itself is cause for respect. Extreme longevity, therefore, is especially admired.

As noted, children are marginal to all aspects of social life in Rindi. But as greater age is especially linked with spirituality, the exclusion of children, and young people in general, from adult society is most pronounced in matters of religion. Thus, I was told, it was the former practice to drive away children and younger people whenever the older men gathered to discuss ceremonial affairs or to carry out rites; and to some extent this practice is still observable at present. Young people, including young adults, in Rindi are called *mahalimu* or *mahalela*, 'light ones', *halimu* and *halela* both having the further senses of 'easy', 'inexpensive', and 'unimportant, of little consequence'. It is significant, therefore, that such profound religious concerns as major ceremonies and ancestral myths are described as *mbotu*, 'heavy', 'serious', 'difficult', 'demanding', and 'expensive'. In parallel language, the Rindi also

describe the young as 'livers not yet broad, hearts not yet large' (*eti ndedi mbàlaru, puhu ndedi bokulu*), thus focussing upon their lack of experience and capability. Interestingly, at the end of a liturgy, a priest will often apply these phrases to himself, in order to indicate that his competence and ritual skill cannot compare with those of his (now deceased) predecessors. In this way, then, the relation of the living and the dead, or of present and past generations, is shown to be analogous to that of the young and the old. Similarly, elderly men in Rindi would often state, with reference to their (supposedly) inferior knowledge in comparison with that of men of former times, that they were only 'new children' (*bidi anakeda*).

Finally, it is worthwhile to recall that, outside of domestic matters, women, too, play little active part in community life in general and in religion in particular. In this respect, therefore, women are like children. Within their own sphere, however, age affects the position of a woman in the same way as it does that of a man; and, moreover, by virtue of their experience, some older women are able to achieve a good deal of influence in categorically male concerns. But although the distinction of sex thus appears to diminish somewhat with age, it is important to note that formally a woman can never achieve a central place in what the Rindi classify as men's affairs. While a few elderly women are recognized to be extremely knowledgeable in matters of religion and custom, therefore, it would be unthinkable for a woman to act as a priest or a speaker. Thus age never completely overrules sex as a criterion of (formal) authority in Rindi.

CHAPTER IX

DEATH

As in similar societies, death, like birth, in Rindi is conceived not as a single unique event, but as a gradual and protracted process of transition requiring at each stage the ritual intervention of the living.¹ Since I obtained rather more detailed information on death and funerary usages than on most other topics, the following account is somewhat condensed; but I have omitted nothing that substantially affects the analysis. The different classes of death distinguished in Rindi are summarized in Sections 7 to 9. I shall begin by describing the procedures involved in what may be called a normal death, referring mainly to commoner funerals and the less elaborate form of the noble funeral. An analysis of major themes expressed in rites and ideas concerning the dead is placed at the end.

1. Preparation of the Corpse

Physical death is recognized by the cessation of breathing and of the pulse. It is said that when the pulse begins 'to rise up the arm', this is a sign that the person has not long to live. When death occurs, betel and areca are set before the body to receive the deceased's forbears, who come to collect him. As they may actually arrive before physical death occurs, a dying man will sometimes claim to see them in the house. Another sign of their presence is an odour emanating from the dead man's clothes for an hour or so just after his decease.

The corpse is prepared by the deceased's clan mates. They first wash the body and rub it with coconut, oil and comb the hair, and dress the deceased in his best clothes. If he is a man, over his usual loin-cloth they place another cloth decorated with red dye. A second decorated textile is provided as a shoulder cloth. The head-cloth is secured with a strip of red material or 'chin strap' (*katanga ngingi*).² The waist is bound with a sash (*ruhu bânggi*) and a rotan girdle.

A female corpse is dressed first in an ordinary black tubular skirt, on top of which is placed a skirt decorated with red dye. Other skirts, tied above the head and below the feet, may later be added to these. A tortoise-shell comb is placed in the hair and sometimes earrings are worn. According to their wealth, the corpses of both men and women may further be provided with precious beads and metal jewelry.

By contrast to the living, who put on clothes according to the rule 'to move to the right' (*palua kawanangu*), i.e., anti-clockwise around the body (as viewed from above), clothes must be placed on the corpse the other way around, in accordance with the rule 'to move to the left' (*palua kalaingu*). The end of a man's head-cloth, which is normally placed erect on the left side, is thus disposed towards the right on a corpse. The inversion also applies to the hair, which is wound around the head in the direction opposite to that followed by the living, so as to 'move to the left'. As I shall later show, this rule of inversion is widely applied in procedures and ideas concerning the dead in Rindi.

A golden pendant or coin is put inside the corpse's mouth. While some people claimed it should be placed in the left cheek, others thought that for a man it should be placed in the right. The two opinions thus express different, though equally valid, applications of the distinction of left and right. Additional golden items may be placed in the hands: in the left hand if only one can be afforded or otherwise in both. Among the nobility such objects might later be placed as well at the bottom of the bundled corpse, so the deceased will sit upon them. I am not certain whether it is hereby intended that they be situated in proximity to the anus. All these metal items, provided by the deceased's clan mates or from his own possessions, are categorically designated *ihi ngaru*, 'contents of the mouth',³ and are intended to serve as the wealth of the deceased in the afterlife.

Afterwards, the arms of the corpse are bent upwards close to the body so that the hands rest on the cheeks, while the legs are folded inwards with the knees close to the elbows, thus effecting a squatting posture. They then tie the limbs in place with a band of cloth, lay the body on its side as though asleep, and cover it with a textile. On the same or the following day the corpse is bundled in a number of decorated textiles (*yubuhu*),⁴ men's cloths if the deceased is male and mostly women's skirts in the case of a female. For this purpose, the corpse should be brought to the clan's ancestral house, though sometimes the corpse is wrapped in another building and then later brought to this house. The deceased's clan mates provide the bulk of

the cloths, though other groups resident in the same village (who might also be affines), or, among the nobility, slave lineages and commoner clients, are also obliged to lend assistance if requested. According to the size and wealth of the clan, and the deceased's standing, less than a dozen or more than fifty cloths may be used. They are first laid out in a criss-cross arrangement in the right front corner of the house and the corpse is placed in the centre in a squatting position. The ends are then tied in stages about the middle of the body. Two saucer-shaped slices of dried coconut, placed together and wrapped in material, are inserted beneath the chin. This is called the 'chin support' (*tula ngingi*) and serves to keep the head erect. The deceased's teeth, and sometimes additional items of jewelry, are also placed inside the cloths. The top of the bundle is then tied above the head with red threads, called *pai kawuku*, 'binding of the (top) knot', while four lengths of material are wound horizontally around the lower, thicker part. All bindings are tied on the left side. Two lengths of material are then wound together in the middle, placed under the corpse, brought up and around the four horizontal bindings, and tied to the highest of these.⁵ With a female corpse, a fine decorated skirt is slipped over the entire bundle, and with both sexes one or more red 'veils' (*tera tamali*) are then draped over the head. All bindings are tied with a granny knot, which, in contrast to the usual reef knot, is counted as an instance of movement to the left.

The corpse is then placed to sit inside a rectangular wood-framed container covered with buffalo hide,⁶ just in front of one of the second set of house posts (*kambaniru hawunjilu*), thus facing the principal house post (*kambaniru uratungu*, see Fig. 4 below). Directly behind the corpse, to either side of the *hawunjilu* post, two bamboo poles are then erected and tied (again with granny knots) to the floor and to the beam above. Between the poles are lashed four bamboo slats or 'rungs' (*wua panongu*). This contraption is called the *hariangu* (from *haria*, 'to lean against') and is intended as support for the corpse's back. But it is also recognized to have the form of a ladder, and, accordingly, is said to facilitate the ascent of the deceased's soul (to God). On each of the two bamboo poles, therefore, they tie a length of red thread designated as *bibitu*, which, as noted, refers to cords wound around the feet to prevent slipping while climbing and is also a prominent symbol in birth rites. In this respect, then, the Rindi represent the process of death in the same way as they do a child's development in the womb. Between the *hariangu* and the corpse

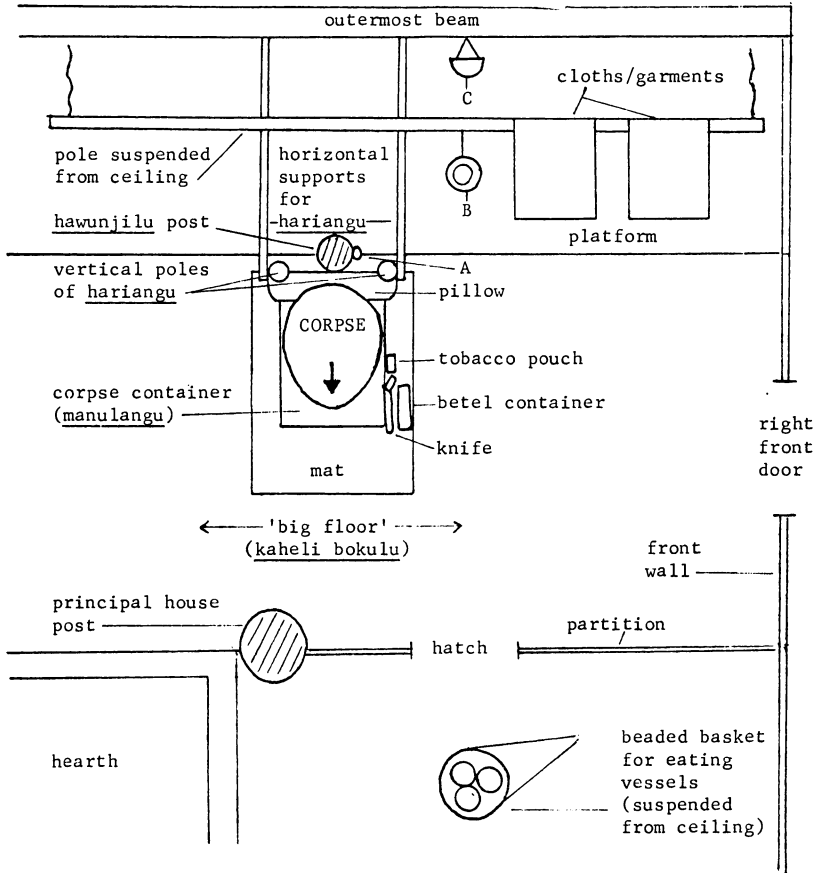

- Key: A — bottle of coconut oil tied to *hawunjilu* post
 B — beaded basket (hung from suspended pole) containing coconut shell with coconut ointment
 C — coconut shell for the earlier dead
 → : indicates direction in which the corpse faces

FIG. 4. Disposition of the Corpse before Burial (in the right front section of the house, as viewed from above)

is placed the deceased's pillow; and the buffalo hide container rests atop his sleeping mat. The deceased's betel purse (or basket) and knife are laid to the corpse's left side. Since the purse is carried on the right in life, this is then another instance of inversion.⁷ Over the raised platform behind the corpse, two cloths (a shoulder cloth and a loin-cloth or woman's skirt according to the sex of the dead person) are hung on a pole suspended horizontally from the ceiling. These were said simply to be for the soul of the deceased. A container of scented masticated coconut (placed in beaded baskets among the nobility) is also hung from this pole, and a tiny bottle of coconut oil is tied to the left side of the house post behind the corpse. These items are later poured onto the gravestone, as I shall describe below. Sometimes another, empty coconut shell is hung at the back of the platform in remembrance of persons who died earlier. The nobility also suspend a beaded container (*kalokatu*) in front of the fireplace; in this are kept the vessels used when offering food to the deceased.

The procedure outlined above is called *pahadangu*, 'to raise up, erect' or 'to awaken'. Accordingly, before this the deceased is said to be asleep, whereas afterwards he is called *manjunga*, 'the one who sits quietly'. Although it is often postponed for weeks or even months, a special meal should be prepared for the dead person on the evening directly after *pahadangu*. For this purpose the bereaved slaughter at least one horse. Some of the meat is cooked, and two portions with rice are set before the corpse. This duality is present on all occasions when the deceased is offered food. One portion, I was told, is for the dead man himself, while the other is for earlier deceased persons. The food is later thrown away behind the house, and the carcass is dragged outside the nearest gate and left for the dogs.

After this, the deceased's agnates, neighbours, and affines must attend or 'guard' (*tutu, dai*) the corpse each night. During the daytime it is sufficient that at least one person, invariably a woman, stay with it. The custom is called *pawàla*, 'to open (the eyes)', referring to the need for at least some of the attendants to remain awake until day-break. While the attendants normally include both sexes, it is the women who play the prominent role, since only they sit with the corpse, offer it betel and areca, and mourn; the men, on the other hand, remain on the front verandah. (If the deceased is male, his widow stays by the corpse more or less continuously; a widower, by contrast, is not so obliged.)⁸ *Pahadangu* thus marks the formal commencement of mourning. Although strictly speaking a horse should

be slaughtered for the deceased each night the corpse is guarded, usually this is done only when affines come to visit. For practical reasons of cost, therefore, they are often not invited, or the rite of *pahadangu* (as opposed to the simple wrapping of the corpse) is delayed all together, until a few days before the burial.⁹

While the corpse is awaiting burial, food and water are set before it twice daily, just before sunrise and just after sunset. While it is of the same sort as that consumed by the living, the food is cooked and served separately. The portions are small, and the deceased is said to partake only of the essence or smell (*wau*) of the food. Afterwards, it is thrown away, and the water is tipped through the floor. Betel, areca, and tobacco are also provided for the dead man. If he was elderly, and hence toothless, the betel and areca are always crushed and held out with the hand.¹⁰ The corpse is thus treated much as if it were a living person; and my wife and I were often invited to chew betel with someone awaiting burial.

I never heard of a minimal period during which the corpse should remain in the house, nor is there now a time limit within which it must be buried. I was told, though, that formerly a nobleman should have been buried within eight days and lower ranks within four days of death (see Kapita 1976a:172, 174). At present, however, the corpse usually remains above ground for a good deal longer than this, not uncommonly for months or, among the nobility, even years. Among higher ranking groups the reason usually given for the delay is the expected high cost of the funeral. Ideally, all affines of the clan, including those who live in distant domains, should be invited and received on the funeral day; and any outstanding litigation between affines (though not the completion of remaining bridewealth debts) must be settled before invitations can be issued and the funeral take place. By contrast, poorer and lower ranking groups, who need invite only the deceased's closest affines, bury their dead relatively quickly, often no longer than a week or two after death. Slaves, whose funerals are organized by their masters and usually do not involve the reception of affines, are often buried after a day or two. A reason commonly given for hasty burial among poorer persons is a lack of cloths in which adequately to wrap the corpse.

A number of rules need to be observed in a house with a corpse. No food for the living may be cooked there, and the fire must be kept burning night and day. Weaving and related tasks are also prohibited, though these activities might be resumed once the corpse has ceased

incest with a woman from a wife-taking clan (e.g., the FZ). The rite is then held in the wife-taker's house.

As a payment for his services, the functionary of the *wai maringu mbana* first receives from the wife-taker a metal pendant and chain with small pieces of gold and silver wrapped in cotton; wealthier parties, I was told, might also provide a horse. The wife-giver then formally transfers to him a length of cloth and a piglet, called the *kamba ndoku ràpa, wei ndoku itu*, 'cloth of an incorrect measure, pig incorrectly carried'. (An alternative to the second phrase is *wei pata itu*, 'pig which breaks the carrying pole'.) *Ndoku*, 'mistake, error, etc.', refers to the fact that the length of cloth is shorter by about one half than those ordinarily given to affines, which normally measure one fathom (*ràpa*). The pig and, accordingly, the pole (*itu*) on which it is carried are similarly undersized. Since the alliance tie is designated as a 'line of cloths, pole on which pigs are carried' (*londa kamba, malinggi wei*), it is clear that these items serve to represent the illicit relation as a marital alliance that is erroneous, false, and substandard. Thus the purpose of the rite is 'to break the pole on which pigs are carried, to snap the line of cloths' (*mbata malinggi wei, mbota londa kamba*), i.e., to dispel the illicit connexion. The functionary of the *wai maringu mbana* then consecrates the piglet and a small chicken to his special deity, and the animals are killed. After a small portion of each is set out with cooked rice as an offering on the front verandah, he then takes the entire carcasses together with the betel and areca used in the dedication, the cooking and serving vessels, the cloth, the carrying pole, and the metal goods, and returns to his house. As all these things are considered hot, they can thereafter be used or consumed only by members of the functionary's clan, who in this way take away the heat of the offence. The purpose of the rite is further expressed with the phrases 'to shut off the river, the river (that is) the gutter around a house, to flatten the mountain, the mountain (that is) the eaves' (*hunggurungu luku, luku kilimbonga, pedahu tandula, tandula ru kawindu*). In accordance with the use of the house as a symbol of alliance, these expressions thus represent the illicit relation as a building, which, by means of this rite, is so to speak demolished.

The next stage of the proceedings, at which the compensatory prestations mentioned above are exchanged, is called 'to sweep the earth where she (or they) sat down, to burn the wood, the wood she (or they) held on to' (*kanjeku tana, tana ngia patungguluna, rokangu*

ai, ai ngia paàpana). As I shall later elaborate, this is one of a number of expressions that represent the transgression as having taken place on the ground, or in other words outside the house. The Rindi also describe this undertaking as 'to bring down the high heavens, to raise up the deep earth' (*papurunya na awangu majangga, paditaya na tana mamajolungu*). The phrases, I was told, allude to the separation of the body and soul upon death; 'deep earth' thus refers to the grave. It was explained that owing to their transgression the guilty couple should actually die, but by means of the rite their deaths are averted or, stated otherwise, they are brought back to life (*paluri beli*). Possibly there is also here the idea of a death preceding a rebirth corresponding to the restoration of order. By bringing down the sky and raising up the earth, therefore, the life that is (potentially) taken away is restored.¹⁰ We might perhaps also understand by this the reconciliation of the wife-giver and wife-taker, who like the sky and earth are hereby brought together again. As noted, a wife-giver in Rindi is conceived to be a source; thus sex with a woman of a prohibited category may be seen to involve a defilement of that source. Accordingly, one pair of phrases that was said to describe an incestuous man, especially, it seems, one who has transgressed with a woman of a wife-taking category, is 'the one who has made turbid the spring (or water source), who has forked the head of the river' (*na makatubaru mata wai, na makarangatu katiku luku*).

That incest is seen to result in a sort of death for the culprits was further suggested by an informant's statement that, like the fine for adultery, the metal valuables given as compensatory prestations and the animals slaughtered are to be regarded as 'grave goods' or 'funerary prestations' (*dàngangu, ihi ngaru*). I was also told that the textiles received from the wife-giver should not be kept long but should soon be used again in exchange, lest they become cloths used to enshroud a corpse (*yubuhu*). The same was said of the horses and metal goods given by the wife-taker.

On this occasion, then, the wife-giver provides a man's cloth and a woman's skirt and the wife-taker reciprocates with a stallion, a mare, and four pendants with chains. The valuables are described as '(that which) brings together the ankles, shuts off the eyebrows' (*pera kuku wihì, pandàbi wuku mata*) and 'the weirs on the dry land, that which shuts out the sun' (*da hapangu la mara, da pandàbi mata lodu*), expressions which allude to a cessation of the sexual relation and a separation of the guilty pair.¹¹ After the exchange, the two

parties hold a cooling ceremony which, by contrast to the previous one, involves the functionary of the 'calm cool water' (*wai maringu m̀anjaku*), in order to neutralize completely the residue of the transgression and to invoke divine favour. One specific aim of the cooling rite is to ensure that no harm is done to the woman's fertility. At this time each party provides a pig, which the other slaughters. The flesh of these animals, I was told, may not be eaten by the guilty individuals; for to do so would be like eating one's own flesh.¹² Wealthier groups may further exchange two pendants and a horse for a necklace of beads and a pair of ivory armbands just before the meal is taken. This transaction is called 'the means by which the brother-sister (i.e., sexually prohibitive) relation is realized' (*na paana mini paanawiningu ẁangu*).

When incest occurs within the clan, or with a married sister, daughter, or father's sister, a further ceremony called *hawari kuru uma*, 'to purify the interior of the house', is required. Some informants thought it need not be held in the case of sex between MBS and FZD, while others thought it should. Since the procedures described above can also be invoked in cases of adultery, it is apparently this ceremony, then, which is specifically concerned with what we would usually call incest. Indeed, as regards sex with the mother or unmarried women within the clan, *hawari kuru uma* is the only ceremony that is performed, as in these cases there is no exchange of prestations. Although in the context of FZ-BS incest, for example, this rite might be thought repetitive, particularly with regard to removing the heat of the transgression from the house, this apparent duplication was said to be necessary owing to the gravity of the offence. When, as in the case of a married Z or FZ, two different clans are involved, I was told the ceremony should be held separately in the woman's marital house and in that of the man.

The rite, which I never saw performed, was described to me as follows. First, by way of a prestation and the slaughter of a pig, the principal engages the functionary of the *wai maringu mbana* to visit the house, in the company of three of the functionary's clan mates, at the rising of the morning star. On their arrival the four men proceed to pound four times on the four outer walls of the building with stones. This is called *k̀ambahu*, 'to knock, beat, or shake out', and is intended to drive the incest out of the house. I was told stones might also be thrown at the roof. On behalf of all the members of the lineage, who at this point are gathered inside the house, the senior

householder then formally enquires why they have been disturbed at such an hour, and the functionary replies that someone inside has committed incest. The householder then says: if that is so, 'put life into my eyes (or face), cool my liver' (*pamiripu matunggu, pamaringu etinggu*), to which the functionary responds by requesting the occupants to come outside.¹³ Everyone then descends to the river's edge. Over her usual clothing, the guilty woman wears an extra skirt, and the guilty man an additional waist cloth. She also carries a dog, and he a chicken.¹⁴ The two individuals then enter the water, thus immersing their clothes and the two animals. After replacing the dog and the fowl on the bank, they remove the skirt and waist cloth and allow the garments to float some short distance downstream, where the functionary of the *wai maringu mbana* waits to retrieve them. He retains both the clothes and the animals, and later sacrifices the fowl to his special deity. The dog, on the other hand, is not killed; its only purpose, I was told, is to bark so as to drive away 'what is warm and hot' (*na mambàraku, na mambana*).¹⁵ Since the garments evidently represent the crime of incest and, in a sense, the incestuous persons themselves, by actually allowing the clothes to float down the river this performance provides a clear visual expression of the general idea that what is hot must be removed downstream and eventually out to sea in order to effect a purification.¹⁶ Afterwards, another rite of cooling, involving the *wai maringu mánjaku*, is held in order to cool the incestuous woman's marriage and to ensure her fertility and future prosperity.

4. Summary Remarks on the Significance of Sexual Transgression

I mentioned above that illicit sexuality (*njuraku*) is represented in Rindi as taking place outside the house and on the earth. One of several expressions of this idea is the description of incest and adultery as 'using the earth as a sleeping mat, and stones as a pillow' (*topungu tana, nulangu watu*). This does not of course mean that forbidden sex is thought always to occur outside a building, but rather, I suggest, that such behaviour lies symbolically outside the bounds of social order, which is represented, in particular, by the house. Accordingly, the Rindi say the place of (legitimate) sex is inside a building with a raised floor.

Sexual transgression can thus be said to result in a confusion of the inside and the outside. It is 'wild' behaviour brought into the

community which defiles the house and creates disorder within the group or groups with which the house is associated. With reference to the clan ancestor, who is in a sense the principal occupant of clan buildings, therefore, one aim of rites employed to dispel incest and adultery is 'so that he (the ancestor) will not drink water mixed with weeds, or eat rice mixed with earth' (*ka àmbu na-unu mangu rumbangu, nga mangu tanangu*). Here 'weeds' (*rumba*, see Chapter II, Section 4) and 'earth' refer to illicit sex, which is thus seen to pollute the food and drink offered to the ancestor and so cause him to exact retribution. In respect of these associations, however, the disorderliness of sexual transgression further accords with the notion of the outside (in this case the area outside the house and village) itself being a source of disorder. A guilty couple are thus described as 'being like the entrails of a wild chicken, the liver of a wild pig' (*paura manu tatangu, paeti wei rumbangu*), since by contrast to the livers and entrails of their domesticated counterparts, which are used in augury, those of wild animals are said to be useless for this purpose; they were in fact described as disorderly. At the same time, the Rindi regard illicit sex as an offence against the earth;¹⁷ thus when the act is indeed committed on the ground, a rite of atonement must be held at the spot lest the earth take revenge on the culprits. As sexual transgression is also threatening to crops, at the annual rites performed at the agricultural altars metal flakes are offered to dispel the consequences of any such offences that may have been perpetrated on the land. Indeed, since cultivated fields are situated on land that has been cooled, in this context illicit sex was said 'to make the earth hot again' (*pambana beliya na tana*).

Being contrasted as cool and hot, therefore, the identification of licit and illicit sex with the inside and the outside respectively corresponds to a wider complex of symbolic associations that is fundamental to Rindi ideology (see Chapter VI). Since, as I have illustrated, unions that are judged in some way incorrect must be ritually cooled if they are to be accepted, these contrasts can also be discerned with regard to correct and incorrect marriages. Correct marriage, moreover, is symbolically connected with the inside in that it falls within the bounds of social order and, more specifically, because it is conceptually located within a wider alliance, sometimes represented as a house. As noted, marriage that deviates from the proper order implies 'movement to the left' (*palua kalaingu*), a principle extensively bound up with death, whereas correct marriage is viewed as an instance of the

opposite principle — ‘movement to the right’ (*palua kawanangu*) — which constitutes the essential condition of life and well-being. In this area of Rindi representations, therefore, there is a significant degree of correspondence between various binary contrasts of the most general kind. To summarize, then, these are related as follows: sexual transgression (*njuraku*) : proper marital or sexual relations :: hot : cool :: outside : inside :: left : right :: death : life.

CHAPTER XVII

PRESTATIONS

Before describing the various ways in which marriages are contracted in Rindi, it is useful to consider more closely the question of marriage prestations, or what are usually called bridewealth and counter-prestation.

1. *Components*

As I have shown, the exchange of prestations at marriage is one instance of a wider pattern of gift exchange between allied groups or, more generally, between two parties who are in some way opposed as superior and inferior. In contrast to the wife-taker's prestation on other occasions, however, the goods given in exchange for a wife are specified as *wili tau*, 'price, worth of a person'.¹ The wife-giver's prestation is then called *mbola ngàndi*, or, more completely, *mbola ngàndi, kahidi yutu*, 'basket(s) brought along, knife carried in the hand'. The first phrase refers to the practice of placing the goods in baskets, and the second to a woman's knife that is included with these.² While the expressions can be applied to the entirety of the bridewealth and counter-prestation, in a narrower sense they refer to the principal portions of each, which formally complete the marriage transactions. Like other prestations given by a wife-taker (or another party who is contextually an inferior), bridewealth consists of horses, metal pendants (*mamuli*),³ and chains of plaited metal wire. The counter-prestation comprises mostly textiles, but also *anahida* beads (Indonesian *muti salak*), ivory armbands, and the woman's knife. (This last item is given only at marriage.) Although they are not consistently confined to one or the other gift, the use of metal goods and textiles as bridewealth and counter-prestation is widespread in Indonesia; and, as in this case, the two sorts of prestations are not uncommonly distinguished as masculine and feminine goods. In Rindi,

the femininity of the counter-prestation clearly accords with the fact that it is transferred in the same direction as the bride; it is 'what is brought by her' (*na pangàndina*). The masculinity of the bridewealth, on the other hand, is consistent with the Rindi evaluation of it as the more costly and hence superior of the two prestations, as well as the association of its components with men. It is thus the superior party, the symbolically masculine wife-giver, who receives it.

Though the distinction of gender applies categorically to the two sorts of prestations, as Onvlee (1949:453) has observed each is further divided into masculine and feminine components. Thus horses given as bridewealth include both stallions and mares, while metal chains are considered masculine and metal pendants feminine. Furthermore, the pendants themselves, while categorically feminine, comprise male *mapawihi*, 'ones with legs', which have animal and geometric motifs fashioned at the base and around the edges, and female *makamuluku*, 'bare ones', which are undecorated. Although Onvlee does not expressly say so, Rindi informants confirmed that in opposition to horses, which as a class are masculine, all metal valuables are feminine. Recalling that, in context, women are associated with the inside of the house and men with the outside, this corresponds then to the classification of the two sorts of wealth (*banda*) as 'goods on the plain' (*banda la maràda*) and 'goods in the house' (*banda la uma*).

In accordance with the genders attributed to the more or less rounded pendants and the long slender chains, the Rindi recognize their shapes to resemble the female pudendum and the male penis respectively; hence on one occasion they were described as 'things that provide fertility and prolificity'. Several facts suggest that the two sorts of metal valuables are also symbolically equivalent to long slender betel fruit and round areca nuts. Thus marriage prestations are placed with a quantity of betel and areca in plaited trays of the sort used to offer these chewing ingredients to honoured guests and to spirits, while in other parts of Indonesia betel and areca are themselves widely used as marriage gifts. Several named portions of bridewealth in Rindi are moreover designated with phrases that refer to betel and areca.⁴ Although I cannot confirm whether they distinguish betel and areca as masculine and feminine, it is worth noting that these equations are made on Roti, where the chewing of these items is considered symbolic of the sexual act (Fox 1968:317, n.). In Rindi, the sharing of betel and areca by a man and a woman similarly connotes a sexual relationship. Therefore, *pakutangu*, 'to offer one

another betel (and areca)' means 'to be in love', while *kuta*, 'betel', is one word for 'lover'.

The contrast of gender is somewhat less clearly expressed among the counter-prestation goods. Since textiles are categorically feminine, however, the masculine component of the gift is evidently the woman's knife and the beads and armbands, in which regard it seems relevant that in contrast to textiles these latter items are all products of male labour.⁵ Once I was shown a fragment of an iron hoe and some unspun cotton that had been placed inside a basket of textiles given long ago at the marriage of a noblewoman. (The custom is apparently no longer followed.) These objects, I was told, symbolize the two kinds of women's labour: agricultural work, which takes places outside, and weaving, which is done inside the house (or, more exactly, beneath the building or on the verandah). We thus encounter here the same contrast as is shown by the two major components of the bridewealth. The textiles themselves include both men's cloths (*hinggi*) and women's skirts (*laiü*); and when a pair of cloths is given, one will be masculine and the other feminine.

The combination of masculine and feminine qualities is enjoined by rules that govern the composition of the individual increments of which a total marriage prestation is composed. In the first place, a pendant should always be given with a chain.⁶ This is the minimal prestation, which when given in exchange for a length of material (*tera*) serves to mark minor communications between allied groups (e.g., the setting of a time for a future meeting). It is also the most basic expression of the masculine/feminine distinction; thus while a pendant and a chain can be given without a horse, the reverse is not possible. Pendants can be used individually or in pairs consisting of one male and one female piece. A single horse is given with either one or a pair of pendants; and individual, named prestations may include either one or two horses. When two horses are given, one should be male and the other female. A major increment of bridewealth in Rindi thus typically consists of two pairs of pendants, a stallion, and a mare. With the most expensive prestations, the number of horses may be raised to four, but this appears to be an elaboration of a more basic quantity.⁷

The composition of marriage prestations also reflects the value attached to even numbers, especially four and eight. In this context, the quality of evenness (or completeness) is clearly founded on a duality deriving from the prescribed combination of masculine and

feminine values. Thus it is easy to see how various applications of this principle, and the concomitant symbolic equivalence of the number two and its multiples (see Onvlee 1949:452), permit a systematic expansion (or reduction) of quantities with regard to individual prestations. Briefly, this involves treating a basic male/female pair (e.g., a pendant and a chain) as a unit (in this case feminine) when conjoined with another unit (e.g., a horse) of the opposite gender. The process may then be continued until the limit of two stallions, two mares, and four pendants, is reached.

The standard amount of counter-prestatiion for a pair of horses in Rindi is a man's cloth and a woman's skirt, and for one horse a textile of either sort. In major exchanges, I was told, a length of cloth (*tera pandàpilungu*; *pandàpilungu* is 'coupled, side by side') should be presented with each decorated textile; but nowadays this seems often to be dispensed with. Onvlee (1949:453) similarly mentions a Mangili prestation comprising one man's cloth, a skirt, a headcloth (*tera*), and a man's waist sash (*ruhu bànggi*),⁸ given in exchange for two horses and four pendants. In these instances the additional textiles appear to complement the man's cloth and woman's skirt in the same way as metal valuables complement horses. The most expensive sort of prestation provided by wife-givers in Rindi, however, includes, in addition to cloths, a string of beads and a pair of ivory armbands.

2. Valuation

The total value of a bridewealth varies according to the way in which a marriage is contracted, which affects the number of increments required and which in turn depends on the rank and wealth of the two parties and the tenure of their alliance.⁹ In addition, the quantity and quality of the goods is open to negotiation between the two groups, both prior to the transactions and while they are in progress. While bridewealth is thus often the subject of more or less protracted bargaining, this is not so with the counter-prestatiion. As noted, however, the two prestations should be in proportion, otherwise the marriage will not prosper. An inadequate counter-prestatiion also reflects badly on the bride, since it suggests that her father considers her to be of little value (see Onvlee 1973:89).

Apart from the number of components, the value of a bridewealth varies according to such factors as the size, colour, and sex of the horses, and the metal content of the pendants and chains. While

pendants are classed as either golden (*rara*, 'red') or 'silver' (*bara*, 'white'), individual pieces can vary considerably in their actual gold or silver content. Pendants consisting largely or entirely of tin (*tambaka*), moreover, are classified with those of a high silver content as 'white'. Both decorated (male) and undecorated (female) pendants may be either golden or silver, though the former are mostly golden. Decorated 'white' pendants are consistently of a high silver content. While I found marked disagreement regarding the gender of gold and silver (i.e., red and white) in Rindi, in this context at least, the majority opinion seemed to favour gold as the masculine metal, because of its higher value. Accordingly, when two pendants are given, a preferred combination is one decorated golden and one undecorated silver piece. If there are two pairs, then one decorated silver and one undecorated golden pendant may be added to the above. But it is also possible to give two pendants that are both golden or silver. Golden or decorated pendants are never transferred individually (see Onvlee 1949:453). In fact, single pendants seem invariably to be undecorated (feminine) ones of tin, which thus appears to accord significantly with the femininity of these ornaments as a class, in contrast to the chains. Major prestations, on the other hand, always include at least one golden pendant among the one or two component pairs.

The bulk of plaited metal chains are of copper wire (*lulu àmahu wudu*). These may be paired with any sort of pendant.¹⁰ For the most expensive prestations, which include pendants of high gold or silver content, however, golden and silver chains (*lulu àmahu rara/bara*, *kanàtaru*, and *halakululungu*) are sometimes used instead. The majority of these items are owned by the nobility. Where two chains of unequal value are given with pendants of unequal value, the more valuable chain belongs with the more valuable pendant. Pendants of gold and silver, and those with decoration, as well as golden and silver chains, are more prominent in marriage than in other instances of exchange between affines. Indeed, among commoners, who possess relatively few metal goods of the highest value, their use is virtually restricted to the principal portion of the bridewealth.

Variations in value among individual components of the counter-prestation are mostly accounted for by the mode of decoration and the colours of the textiles. Of the two sorts of men's cloths, for example, those decorated with red (*kombu*) dye are more valuable than those with only blue. The most highly valued women's skirts

are ones decorated with extensive embroidery (*laiü pahudu*).

As I remarked earlier, the Rindi speak of bridewealth in general as costly and difficult to muster. Indeed, while there are no absolutely fixed quantities, and the amount can vary considerably according to the factors mentioned above, in comparison with what is required in other Indonesian societies bridewealth in eastern Sumba can generally be called expensive. Thus, considering only horses,¹¹ even the simplest of marriages can involve the transfer of half a dozen or more animals,¹² and judging from informants' statements, payments that include 20 to 30 horses are not uncommon. With regard to a recent marriage between a wealthy Rindi commoner and a woman of lesser noble rank from Mahu, I was told on good authority that the entire prestation (which had already been discharged) comprised 100 horses; but this seems exceptionally high and was evidently due to the fact that the wife was of higher rank than the husband (see Chapter X). Both Roos (1872:49) and Kruyt (1922:500) state that eastern Sumbanese bridewealth is so high that many persons cannot marry. But this would seem to be somewhat exaggerated, as I did not find a high proportion of Rindi people who had remained unmarried for this reason. As I shall show in the next chapter, moreover, marriages can be contracted with a reduced bridewealth, and the payments can be spread over a number of years.

Bridewealth in eastern Sumba has by all accounts undergone a marked inflation, probably beginning 150 to 200 years ago. Formerly, I was told, the prestation comprised only a dog and a quantity of brass or other metal.¹³ The use of horses as marriage prestations is thus evidently a relatively recent innovation; so it would appear that the inflation has been mainly due to the expansion of stock raising subsequent to the creation of an export market in the mid-nineteenth century and the introduction of precious metals in the form of foreign coins given as payment for the animals. Kruyt (1922:500-01) thus states that whereas bridewealth in Kambera at one time consisted of only two or three horses, by about 1920 it had come to include from 15 to 20 or from 50 to 100 'golden ear pendants' and a great number of horses and buffalo.¹⁴

3. *Division of the Bridewealth*

Since a more detailed description of the component prestations entailed in the various forms of contracting marriage appears in the following

chapter, here I shall briefly outline only the major, named portions of bridewealth involved in the more expensive procedures. The exchanges that complete abbreviated marriage procedures are considered to be merely 'reflexions' (*mai*) and not true equivalents of these. As mentioned previously, the total bridewealth is divided into two parts: (1) the *pingi wili*, 'trunk of the payment', or *aya wili*, 'senior payment', i.e., the principal portion to which the term *wili tau* more specifically applies; and (2) the *eri wili*, 'junior payment'.

In Rindi, the major portion of the *aya wili* is called the *kundu patini, tularu epi*, 'nudging of the firewood, pushing away of the fire'. This alludes to the bride's mother's period of confinement after parturition, and is given to the bride's parents in recognition of their having raised the girl to maturity. It might therefore be seen as a compensation for their efforts, although 'nudging' and 'pushing away' could also be interpreted simply as a reference to the separation of the woman from her parents.¹⁵ The portion minimally consists of two pairs of pendants, a stallion, and a mare, all of which (in the high form of marriage) are expected to be of the highest quality.¹⁶

The second named portion of bridewealth is the *kuta rara, kaliti pangga*. *Kuta rara*, 'ripe betel' (*rara* is also 'red', 'gold[en]'), apparently refers to the component golden pendants. *Kaliti* is 'riding mount' or, more generally, 'a means of transportation', while the relevant sense of *pangga* here, I suggest, is 'to cross over'. Since the prestation is intended for the bride's mother's brothers, the phrases might therefore be translated as 'mounts that cross over', that is, from the wife-taker to the wife-giver of the wife-giver, thus as it were by-passing the actual wife-giver. In Rindi, the prestation is actually made up of two parts, the 'senior ripe betel' (*kuta rara ayada*) and the 'junior ripe betel' (*kuta rara erida*). The first, which comprises two pendants and a stallion is for the bride's mother's eldest brother, while the second, which consists of a mare and one or two pendants of lesser value is for a younger brother or, so I was told, for the mother's father if he is still living.

Another prestation, which in Rindi is (or was) given only at marriages of the wealthiest nobility, is called the 'ancestor portion' (*tanggu marapu*, see Chapter V). This refers to goods which are in effect transferred from the heirlooms of the wife-taking clan to those of the wife-giver. The prestation minimally comprises a pair of valuable pendants given with two horses. In this connexion, it is worth mentioning the classification of eastern Sumbanese bridewealth outlined

by Kapita (1976a:132), who divides the total payment into two parts, the 'upper platform' (*ladi dita*) and the 'lower platform' (*ladi wawa*). Though I never encountered these terms in this context in Rindi, they otherwise refer to the loft in the house peak — the place of the ancestral spirit — and to the floor of the house. Under 'lower platform', therefore, Kapita lists both the *aya wili* and *eri wili*, while 'upper platform', he says, refers to a prestation of four pendants with chains and four horses that are intended for the clan ancestor.¹⁷ (Interestingly, Kapita's description implies that the major portion of the counter-prestation is exchanged for this part of the bridewealth, whereas in Rindi I was told that it is given in return for the bride's parents' share of the *aya wili*.) Onvlee (1973:87) mentions a former practice of giving a piece of unforged gold or a pendant to be added to the relics of the wife-giving clan that are stored in the peak of their ancestral house. This custom was said formerly to have been observed in Rindi as well, but it has now fallen into disuse.

Marriages of the very wealthy occasionally include another prestation for the wife-giver of the wife-giver, specifically the bride's mother's father or his heir.¹⁸ This is called the 'stake for the kapok and dedap tree' (*tandai rānga, tandai wālakeri*), and consists of a large stallion and two valuable pendants. The gift was described as a means of securing fecundity and prosperity from the recipient, which seems to involve the idea of the wife-giver's wife-giver as an ultimate source of well-being (see Onvlee 1973:92) and the desire that what this party has provided to the bride's group should now be extended to the groom's. *Tandai*, which denotes a wooden stake or living tree that supports climbing plants, thus suggests a life-sustaining function, while the two trees mentioned in the name of the prestation were said to represent the male and female genitalia. I was also told that, in contrast to their normal sitting position, the ritual speakers who convey the prestation should stand up while doing so.

Each of the prestations described above is reciprocated with a pair of decorated textiles (a man's cloth and a woman's skirt), while, in addition, a pair of armbands and a string of beads are given in exchange for the parents' portion of the bridewealth (*kundu patini, tularu epi*). The goods are then placed in one or more baskets bound with strips of cloth, which are not opened before the wife-takers have returned to their village. This principal part of the counter-prestation is distinguished as the *pingi mbola*, 'trunk of the baskets'. The various increments do not have individual names, though each can be specified

as the *papa*, 'complement', 'counter-part', of the portion of bridewealth in return for which it is given.

Once the principal bridewealth (*aya wili*) has been transferred, the exchange of those increments called 'junior bridewealth' (*eri wili*) takes place. As noted, these prestations, which at more expensive marriages account for the bulk of goods transferred between the two parties, are provided by the groom's father's brothers, others of his agnates, and other persons who contract to participate in the marriage. This part of the exchange is also known as 'what is placed in rows' (*pandalarungu*) or 'what is lined up (and) planted, put down (and) rooted' (*pandalaru pamulangu, pabànjalu pangaingu*). The names refer to the wife-giver's practice of arranging individual textiles (a man's cloth or a woman's skirt) in straight lines. Each cloth is provided by one of the bride's father's agnates, the bride's brothers, and other parties on the wife-giving side. They are then inspected and counted by the wife-taker's speaker, who gives a pendant for each textile; and the pendant, which represents a horse, is thereafter transferred to the person who provided the cloth. The horses may be given at the same time or, more usually, at some later, specified date. In the latter case, the animals are thus referred to as '(what is) counted by months, measured by years' (*kapàji wulangu, katutu ndaungu*).

In the more expensive forms of marriage, it is customary for the bride's parents and other close relatives to present the bride with a number of gifts in addition to the increments of counter-prestation exchanged for the bridewealth. Besides additional cloths — some of which are later presented by the bride to her husband's sister (*mangàlu*) — the gifts may include earrings, rings, and other jewelry; and also pendants, in this context described as *pamandara wàngu*, things that can later be used as a means of requesting foodstuffs and the like from the wife's natal group. Among the nobility, the woman's father usually provides the couple with several head of buffalo (*habàba*, 'one herd', i.e., a bull and several cows) and a riding horse, which, formally speaking, is for the bride. Where the husband is to reside uxorilocally, moreover, they will receive the usufruct of a parcel of land. It needs to be stressed, however, that these goods are not reciprocated in any direct or precisely calculable way in the bridewealth and thus do not form part of the counter-prestation proper; they are more in the nature of gifts for the bride, or rather the two spouses together. Kapita (1976a:62) describes them as 'capital' (Indonesian *modal*). While some of the items are of kinds normally

designated as 'masculine goods', therefore, they do not affect the classification of the two sorts of marriage prestations in terms of gender.

As noted, female slaves (*ata ngàndi*) are transferred with the bride at noble marriages, either at the time or subsequently. No additional bridewealth is given for these women when they themselves later marry; and though the wife-taker's prestation is in a sense considered to compensate the wife-giver for their value, the number of women given is not precisely calculated in relation to the amount of bridewealth. Despite their subordinate status, therefore, these slaves can no more be said to form part of the counter-prestation than can the bride herself. Rather, they are provided in consideration of the position of the bride, whom they will serve, in her marital home.¹⁹

Earlier authors (e.g., Onvlee 1973:89) also mention the practice of providing a noble bride with male slaves. In Rindi, however, I was told that such persons, who are there called *mahimbu kuta*, *mahimbu winu*, 'those who search for betel and areca', are actually the retainers of a noble husband who is formally required to reside uxorilocally for a time (see Chapter XVIII, Section 3). But while these men remove straight away to the bride's father's residence in order to serve her there, until the bridewealth is completed the husband may actually remain for most of the time in his own village. Such male slaves marry female slaves (*ata ngàndi*) of the bride.

4. *The Significance of Marriage Prestations*

I have already demonstrated that the payment of bridewealth secures the incorporation of the wife and her offspring into the husband's clan. That this, rather than the establishment of other rights, is the major significance of the prestation is especially made clear by the institution of *lalei tama*, 'marriage by entry' (see Chapter XV, Section 6), where the husband's right to the woman's sexuality and other services is the same as in other forms of marriage, but owing to the absence of bridewealth, the woman and her children belong to her natal clan.²⁰ The relation between bridewealth and incorporation therefore accords with the wider ideological significance of the gift as something exchanged for prosperity, in particular the possibility of continued existence for the wife-taker's lineage. As noted, valuables of the sort used as bridewealth, specifically precious metals, are also offered and consecrated to the clan ancestor and to other forms of

to smell.¹¹ I never heard a reason for the ban on weaving. Like the requirement that the fire be kept burning, however, it is reminiscent of rules that apply during a woman's pregnancy and her subsequent confinement. I cannot recall ever hearing that the fire is specifically intended to warm the corpse; but were this so the usage could be counted as an instance of warming preceding reincorporation in transition rites, as in respect of a new mother or initiated youths. Moreover, in the case of a new mother at least, warming is aimed at restoring the body. That the fire is kept burning 'to keep malign influences at bay', as Hertz (1960:42) suggests, does not seem likely in Rindi.

I mentioned that a pregnant woman and, after the birth, her child must avoid all contact with corpses. This opposition of birth and death is further shown by the fact that a woman in childbed and during confinement occupies the left back corner of the building facing outwards to the back, whereas a corpse sits in the right front corner facing inwards towards the hearth. A corpse is also taken out of the house for burial through the right front door, thus facing towards the interior front wall of the building. As I remarked with regard to birth, however, since houses are variously disposed within the village, the corpse's position is not regularly oriented with reference to the cardinal directions.

It is also required that silence be kept in a house that contains a corpse. Singing, dancing, and other festivities are thus prohibited, and rites concerned with other matters may not take place there. These restrictions extend to the whole village and, traditionally, when a nobleman died, to the entire domain. Formerly if commoners breached this rule, for example by contracting a marriage, they would have been liable to a large fine. For the Rindi, the governing idea is that the dead should be taken care of before the living or, as they themselves express this, that matters of death (*lii meti*) should always take precedence over matters of life (*lii luri*).¹²

If burial must be considerably delayed, and there is not enough space conveniently to keep the corpse in the house, after it is wrapped in cloths the body may be stored in a sealed wooden chest (*pàti*). This is then placed inside a compartment, built in the middle of the right side of the building. When this is done there is no need to observe the restrictions that normally apply to a house with a corpse, until the compartment is dismantled and the corpse placed with the *hariangu* and other paraphernalia in the right front corner. This should

be done an even number of days before the burial. Although I was told the body should then be removed from the chest, on the one occasion I was able to observe this practice, it was so decomposed that they decided to bury the chest as well. Another recourse in these circumstances is to bury the corpse quickly with very attenuated rites, and without the participation of affines, on the understanding that the full procedure will be carried out at a later date. This is called 'to have, use a tall back support, a deep container (for the corpse)' (*hariangu majangga, manulangu manjubuku*). As the phrases imply that the grave takes the place of these items, the procedure may be understood as a form of temporary burial. The Rindi thus say of someone interred in this way that he is actually not yet buried. The procedure seems most usually to be followed for lower ranking and undistinguished members of commoner clans. While I was told that the remains should then later be exhumed, brought back to the house, and reburied with the full ceremony, I have the impression that sometimes the matter is just left.

If a corpse must be carried to another village to be prepared for burial, other persons, being warned in advance, will return to their homes and avoid the route. This is because witches and malevolent spirits are attracted to the dead man. For the same reason, the bearers perform a simple rite to prevent these beings from following the corpse. Although I cannot say I noticed it, I was also told that on the day a man dies people are reluctant to pass his house or even to leave their own homes. These precautions, however, concern only a corpse that has yet to be wrapped. Once it has been prepared for burial the corpse is not an object of fear, and I found little to suggest that it is thought dangerous to the living. The common idea that the deceased might attempt to take the living to the grave with him seems only to concern his spouse(s) and children, on whose behalf a rite 'to separate the souls' (*pahewangu hamangu*) is held shortly after burial. This is also done before a widow is taken to wife by one of her husband's agnates. The custom of wrapping the corpse, and certain restrictions placed on the house, thus seem to effect a separation of the deceased from the living. Since the gradual transfer of the soul to the afterworld also begins at this time, it is appropriate, then, that the corpse is placed in that (superior) section of the house reserved for communication with the ancestors and the deceased forbears. In fact, the position and orientation of a corpse are precisely the same as those of a priest engaged in invocation. While in this marginal

state, the dead person is treated with great respect, and the living become subservient to his every need. Similarly, in the context of rites, the officiating priest is always served with food before other persons, including noblemen, who may be present. In this regard the status of the deceased is also comparable to that of initiates and other persons in a marginal or transitional state (e.g., the special attendants of a noble corpse, see Section 9 below), who are accorded special privileges as well. Regardless of his rank in life, therefore, women often address the dead person in mourning chants as if he were of high noble rank.

2. *Burial*

Burial (*taningu*)¹³ commences in the late afternoon and must be completed before sunset. The burial day is called 'the morning of descent, day of departure' (*mbaru puru, lodu laku*). It is thus thought of as the beginning of a journey. With regard to these phrases, the fact that it actually commences in the evening also suggests that night and day are inverted among the dead.

A corpse may be interred in a new or old grave. There are definite rules concerning joint burial. Wives should be buried with their husbands. Those who may not be buried together include persons in adjacent genealogical levels (e.g., father and son), with the exception of small children; wife-givers and wife-takers (e.g., WB and ZH); and prohibited spouses in ego's generation (e.g., brother and sister), even while they are infants. That WB and ZH cannot be buried together was attributed to the fact that their respective wives (viz., BW and Z) are prohibited as spouses. Presumably HZ and BW (w.s.) may not share a grave for the same reason. To bury opposite sex siblings together was described as *panjurakungu*, 'like incest'. Interestingly, the same judgment is passed on opposite sex twins, with regard to their simultaneous occupation of the same womb. While it is stated as a generalization that persons who cannot marry may not be interred in the same grave, nevertheless grandparents and grandchildren, regardless of sex, can be and very often are buried together. The practice, then, is consistent with the identification of alternate generations (and the opposition of adjacent generations) shown elsewhere in Rindi thought. Although it is not prohibited, some people said it was preferable to bury brothers separately. This, I think, is so that members of distinct descent lines may later be kept apart. It is always possible,

however, to relocate the remains of earlier deceased persons at future burials. Sometimes a single grave stone covers two adjacent cavities; as these are then counted as separate graves, the rules noted above need not be observed (see Anon. 1926:577).

As it is customary informally to invite the inhabitants of surrounding villages, and the nobility, the burial is the most public of ceremonies in Rindi. Affines, who are formally invited well in advance, arrive earlier in the day or on the previous day. On arrival, the women of a group immediately proceed to the house, where they squat weeping around the corpse, while the men remain on the front verandah.¹⁴ Both sexes are received with betel and areca provided by each house in the village. When an existing grave is to be used the stone is removed earlier in the afternoon. The women, bearing an offering of betel and areca, first go to the grave to mourn, and a priest recites a brief liturgy. Among the wealthy, one or more horses may be slaughtered at this time. Any remains are then taken out of the grave, wrapped in a man's cloth or a woman's skirt (according to the sex of the last occupant), and put back. A pair of cloths is placed over the grave mouth; and at noble funerals I attended, two women held an umbrella over it to shade the previously deceased. It is relevant to note, then, that the topmost gravestone is called the *dira lodu*, 'limit, boundary of the sun'. This evident antipathy between the dead and the sun agrees, of course, with the association of the dead with the sunset and the night. A new grave is covered with a plaited mat on which the corpse is later placed to sit. Among the nobility, a gong it sometimes put beneath the corpse in the grave. The grave cavity is round, with a diameter of perhaps 60 cm (just large enough to accommodate the bundled corpse), and over a metre in depth.¹⁵

Just before the corpse is taken from the house (*papurungu*, 'to bring down'), a horse is brought to face the building and slaughtered. As with all horses killed at the funeral, ribbons, which are usually and by preference red, are tied to the animal's forelegs, tail, and sometimes to the harness above the muzzle. The liver and heart are taken, cooked with rice, and set before the deceased as his final meal before departure.¹⁶ Afterwards the food is cast into the village square. The men then prepare to carry the corpse to the grave. There are no rules concerning who may assist in this task. At this point the female agnates and affines of the deceased, who are still clustered around the corpse, amid a cacophony of weeping and shouting make a more or less token attempt to prevent the men from removing it. In one

case I heard of, the women put up such resistance that in the struggle part of the wall and floor collapsed. Normally, though, they soon move to the front verandah and thence to the grave. The possibility of resistance from the women may be the reason why the pall-bearers' passage to the grave is typically hurried. Although this was also referred to the (often atrocious) stench of the corpse, they move no more slowly when it is already old and no longer smells. The general point, I think, is that removing the deceased to the grave represents a crucial transition that must be got over with quickly.

The procession to the grave is led by one or two women (often young girls) who carry the deceased's betel container and knife and a bowl or tray of copper or brass containing a quantity of betel and areca and the containers of coconut ointment and oil mentioned earlier.¹⁷ The metal bowl, called the *kaba julangu* (*kaba*, 'bowl; *julangu*, 'tray, dish') is carried atop a red cloth, which in turn is placed, according to the deceased's sex, over a decorated man's cloth or woman's skirt. I shall describe the ritual use to which these items are put just below. Thereafter follows a man leading a stallion, designated as the mount of the deceased. The horse, on which the soul rides to the grave, should be held on the animal's left side, since contrary to the living, who mount and dismount on the right, the dead do so on the left. At noble funerals I attended, a saddle consisting of a folded mat covered with a decorated cloth was fastened with a strip of red material tied on the left (with a granny knot) to the horse's back. Another man held an umbrella covered with a red cloth at the animal's left side over the saddle. The men carrying the corpse then follow. In Rindi the body is lowered into the grave from the right side and disposed so as to face downstream, because the soul first travels to the river mouth before continuing its journey to the land of the dead. Here, then, we should recall the association of the downstream direction with impurity (see Chapter III). After the body is placed in the grave, the veil is then removed and the top of the bundle unfastened. This task, called 'to seize (*or* open, release) the knot' (*àpa* or *wàkahu kawuku*), I was told, should be carried out by a wife-taker of the deceased's clan.¹⁸ As *kawuku* also refers to a top knot or bun, this part of the bundle seems to represent the dead person's hair. Accordingly, the dead in general are described as 'the ones with rolled out hair' (*da mawalahungu lunggi*).¹⁹ Since the crown and the knot of hair are associated with the soul in Rindi, it would appear, then, that untying the top of the bundle is symbolic of releasing the soul.

After the top of the bundle is untied the ends of several cloths are quickly torn, a custom which was explained as a way of making the deceased appear impoverished, so that he will not be plundered on his way to the land of the dead.²⁰ It could also be interpreted, however, as one of several instances of a deliberate destruction of goods, which is a common feature of funerary rites in many societies. Another is the practice of felling a number of coconut, betel, and areca trees belonging to the deceased (between 6 and 14, though always an even number, in the cases I recorded) just before the burial or on the following day. This custom is connected with the practice, which some Rindi follow, of planting a coconut or other fruit bearing tree, in the former case called *kokuru paranja dedi*, 'coconut conterminous with birth', after a child is born.²¹ If the tree does not thrive, it bodes ill for the child's well-being. The trees cut at the funeral serve as the dead man's possessions in the afterworld. The periodic slaughter of livestock mentioned in several places above is rationalized in the same way. The animals are called *dàngangu*, 'accompaniment', a word Kapita (1974) compares with *dàngu*, 'with'. The number varies markedly with the wealth of the deceased, and among the nobility a great many buffalo as well as horses are slaughtered. Since these are considered the property of the deceased, their flesh is not eaten.²² *Dàngangu* was also said to refer to male and female slaves who formerly were put to death at a nobleman's funeral to serve as his retainers in the afterworld. In each instance, therefore, the earthly, material form of an object is damaged or destroyed in order to render it useless to the living and so transfer it to the world of the dead (see Hertz 1960:46). In the case of slaughtering livestock and felling trees, the Rindi also claim these practices allow the animals and plants that remain to thrive and multiply, which idea thus expresses a reciprocity between the living and the dead.

After the corpse is placed in the grave, the buffalo hide tub in which it is carried is scoured out with dirt in order to transfer all the bodily fluids to the earth. With the dead man's mat, pillow, and back support (*hariangu*), it is then taken outside the village and tied or suspended at the top of a tall tree.²³ The only reason given for this practice was that it prevents animals from consuming what might remain of the corpse, as they would then be unfit to eat. Although the Rindi seem to be particularly concerned about this possibility, the items are never burnt or buried. Burning them, I think, would be injurious to their owner in the same way as would burning menstrual rags or hair.

After the grave is sealed, another horse is slaughtered. Among commoners, this is the mount of the deceased, while among the nobility another horse is killed in its place. In this way, the horse is thought to carry the soul to the land of the dead. The men who have carried the corpse then wash their hands in the milk of a pair of coconuts, which are always provided at the grave side.²⁴

Before everyone returns to the house, the women place a quantity of betel, areca, and lime, and pour the coconut products from the metal bowl (*kaba julangu*) onto the grave stone, as an offering to the deceased. In this context the coconut products are possibly significant as items employed as a cosmetic or therapeutic treatment. According to an interpretation offered by one informant, though, the cream and oil represent the dead man's bodily fluids, respectively his 'fat' and 'oil', which are hereby transferred to the earth.²⁵ This agrees with the fact that the metal bowl in which the coconut products are carried, and the red cloth and decorated textile placed beneath it, represent the deceased's soul. They are thus later placed in the house at the exact spot previously occupied by the corpse, where they remain until the end of mourning; and they are first brought out and made ready for use when the corpse is taken from the house. The ritual names of these items are 'head cover, base of the back' (*pangguru katiku, lata kamundu*). The procedure described above, called simply 'to put down betel and areca' (*bànjalu pahàpa*), is repeated each day, once in the morning and once in the afternoon, until the end of mourning. The deceased's betel purse and knife, and among the nobility the riding horse, are also taken to the grave on each occasion. After the burial, the ordinary guests leave. Affines, however, remain behind to partake in an exchange of prestations, which usually lasts throughout the night and continues during the following day or days.

3. Funerary Prestations

The deceased's agnates (and, if she is a woman, her natal clan as well as members of her husband's clan) are informed of the death immediately. While affines who live close by are also told informally at this time, the death is not officially communicated to them until a formal invitation to the funeral is given. I did not hear of a rule that wife-givers should be invited first. The invitation of affines is carried out by ritual speakers (*wunangu*) and formalized with the exchange of a metal pendant (*mamuli*) — given by the wife-taker —

for a small cloth. Beforehand, the bereaved clan holds a meeting, which co-villagers and affines who live nearby also attend, to discuss the date and arrangements for the burial. The deceased's own wife-giver (or natal clan if she is a married woman) should also be represented. When agreement is reached, a pig is dedicated to the clan ancestor and other deceased members of the clan to confirm the date. While it is the dead man's agnates who are first of all responsible for providing for the funeral, it is customary at this time to solicit assistance, especially in the form of animals for slaughter, from co-resident clans and affines who live nearby. The assistance is reciprocated at later funerals.

While the Rindi say all groups affinally related to the deceased's clan should be invited to the funeral, this is normally done only among the nobility and higher-ranking commoners, or when the deceased belongs to the clan's most senior line. The scale of affinal involvement thus reflects the status of the dead person. Funerary prestations brought by wife-givers are called *yubuhu*, *karàndi*, the same terms which designate the cloths used to wrap the corpse, while a wife-taker's prestation is called *dàngangu*, *ihì ngaru*, which terms refer respectively to livestock slaughtered for the deceased and the metal goods buried with the corpse. In this way, then, affines contribute symbolically to the funeral. The exchanges, which usually take at least one day to complete, are either begun immediately after the corpse is buried or earlier in the day, thus before the actual interment. In the latter case a special manner of ritual speaking is employed; this is called *wotu la njara*, 'to place (the deceased) on horseback', thus referring to the departure of the dead man signified by the imminent burial. Although it is said that wife-takers should bring two horses and two metal pendants with chains, usually one horse and one or two pendants is judged sufficient. Wife-givers bring a decorated man's cloth or woman's skirt, according to the deceased's sex.²⁶ The prestations are then reciprocated accordingly by the host clan, and a pig is slaughtered for each affinal group.²⁷ Usually each affinal clan as a whole gives and receives just one set of prestations, and receives just one pig, but exceptionally, with the deceased's closest affines (or agnates, in the case of a married woman), a number of separate increments, each representing a different man of the affinal group, are exchanged. Sometimes, moreover, an additional pig is slaughtered in recognition of the attendance of the women of the group. Special, individual treatment of this sort is most often reserved for the dead man's wife's

father and brothers or a woman's closest male relatives. The exchanges, carried out by speakers, are occasionally subject to some protracted negotiation, though not nearly to the same extent as are marriage transactions.

There are two additional forms of transaction that often take place at a funeral. One sort, which involves the same amounts as the principal funerary prestation, is called 'the unwatched, the unobserved' (*pandaimingu, pandangadu*). This is given on behalf of a previously deceased member of the host clan whose funeral the affinal group did not attend. The usual reason given for not attending a funeral is a shortage of goods; wife-takers must bring at least one horse. The other sort of prestation (one cloth or a pendant and a horse) which may be given at this time is called *lii luri*, 'concerning life', or *lindi luri*, 'life connexion', and is intended to reaffirm the alliance relation. Only the most closely related affines, or those who wish to publicize their intention to continue giving or taking wives, partake in this. Non-related parties who attend a funeral are expected to bring a small gift — a piece of cloth, money, or a pendant — but these are not reciprocated. The gifts are spoken of as things which the deceased may exchange for betel and areca on his way to the land of the dead. In practical terms, they help to offset the expense of the funeral.

While prestations given to and received from affines usually just about strike a balance, the host is not of course directly compensated for the pigs slaughtered, which thus constitute a major part of the expense.²⁸ At larger funerals I attended, moreover, at the end the deceased's clan, while so to speak in profit as regards cloths, was invariably well down in horses, usually the single most expensive items in the exchange. If the horses slaughtered from the beginning of the mourning period and at the burial are also taken into account, it is clear, therefore, that a funeral can be a costly undertaking. A further exchange of prestations of the sort I have just described takes place between affines at the final, *pahili mbola* ceremony, which marks the complete assimilation of all the dead of the clan into the afterworld (see Section 6 below).

4. *Bànjalu Wai Mata: The End of Mourning*

The end of mourning is called the 'putting away of the tears, drying up of the nasal mucus' (*bànjalu wai mata, màdu wai wira*) and the 'putting away of the metal bowl, storing away of the (red) cloth'

(*bànjalu kaba, hundukungu tera*). Although I found the rule was usually ignored in practice, the Rindi clearly state that this should take place three days after burial or, as they sometimes express it, 'four days including the burial day'.²⁹ Until this time the affairs of the house continue exactly as before the burial, except that the place of the corpse is taken by the metal bowl. Food and drink are still set out for the deceased; the women remain in mourning in the right front section of the house; among the nobility, the gongs continue to be played each night; and the restrictions on the living remain in force. Burial thus seems to occupy a medial position between the preparation of the corpse and the end of mourning. The rite which marks the end of mourning begins after the women, before noon, place betel, areca, and coconut products on the grave for the last time. There is little that need be said about the rite itself. A pig and several fowls are dedicated to the clan ancestor, the spirits of the yard altar, the dead person himself, and all the deceased of the clan. Four full portions of food and drink, intended for the dead, are set in front of the metal bowl, while eight smaller portions, for the clan ancestor and the altar spirits, are placed before the priest, who sits to the left of the bowl. Betel and areca are provided in sets of two and four trays respectively. After the meal,³⁰ the metal bowl and red cloth are put away and the deceased's betel container is placed inside a basket (*mbeka*), which is then bound and tied (with a granny knot) and hung up, with those that belonged to earlier deceased persons, above the rack (*hindi maringu*, see Chapter I) to the right of the front door. There it stays until the final mortuary ceremony. The dead man's knife, however, is inherited. The betel container, I was told, should be hung up by a woman with the left hand after nightfall. The two cloths suspended over the platform behind the corpse are also put away at this time, and the vessels used to cook food for the deceased are thrown out.

On the following day, or not too long thereafter, the bereaved perform another rite, which includes a rather elaborated version of the cooling ceremony. One aim of the rite is thus 'to cool the house', i.e., to restore it to its normal condition and to neutralize the heat of death, which is identified in particular with the smell of the corpse. This, then, provides another instance of the association of transitional periods with things hot. Indeed, in contrast to the living, the dead and all things directly connected with them are classified as hot in Rindi.³¹ In part, this expresses the idea that death is antithetical to

life, things conducive to life being regarded as cool; but it is also consistent with the fact that the dead, as spirit, possess power over the living and are therefore owed reverence. Metal goods buried with a corpse may be reclaimed at later funerals. Since they too are considered hot, however, they must first be rendered cool by dipping them in the water used in the cooling ceremony, before they can be used for other purposes, as alliance prestations, for example.

Another purpose of this rite is 'to bring back the souls of the animals, goods' (*pabelingu hamangu banda*), which refers to the livestock slaughtered, and the plant foods and products consumed, during the funerary period. When an animal is ritually killed, its soul, like that of the dead man, proceeds to the land of the dead. The Rindi thus hereby request that the animals be returned 'to the bellies of their mothers and fathers' and the plants 'to their trunks and stems', so that they may be replenished.

5. *The Location of the Soul*

Before discussing the final mortuary ceremony, it is useful to consider Rindi ideas concerning the fate of the deceased's soul. In this regard one encounters a variety of at first apparently contradictory statements.³² Thus while they sometimes say that the soul goes straight to the afterworld at the time of physical death, it is still shown to be present in the house until the burial of the corpse, which is represented as the beginning of a journey, and indeed afterwards as well, so long as the deceased's betel container remains in the house. This does not mean, however, that they consider it to stay continuously in the house during this time, nor does it necessarily entail that they conceive of the soul, or parts of it, as being in two places at the same time. Rather, the idea seems to be that before the final rite it retains a place within the building. Between physical death and the final obsequies, therefore, the soul is said to come and go (*luangga mai*)³³ between the house and the afterworld. But while it may visit the land of the dead during this time, until the final rite is held the soul is not allowed to enter the chief village there (see Hertz 1960:45), and so must stay in the gardens and subsidiary settlements outside this village.³⁴ A related idea is that it remains for a time just outside the villages of the living. In other words, then, during this period the soul occupies a medial and transitional position between the living and the dead,

the gradual separation of which the mortuary rites are intended to express. Burial, which is a relatively early stage in this process, is thus mainly concerned with separating the soul from the body, regarded as a sort of outer covering.³⁵ Before burial, the soul remains close to the corpse; according to one opinion they sit facing one another. After the corpse is removed from the right front corner of the house and until the end of mourning, the soul continues to be identified with this place. But during this time, and before burial as well, it also frequents the deceased's sleeping compartment on the other side of the house, or in another building. On the evening before burial, therefore, a priest performs a rite inside the compartment to inform the deceased that tomorrow is the day of his departure.³⁶ The liturgy is partly addressed to the deceased and partly to 'the lord and lady present at the belly of the pillow and beneath the mat' (*Umbu Rambu la kambu nulangu, la lumbu topu*), i.e., the spiritual personification of the sleeping place. The rite especially concerns the immortal aspect of the soul, the *ndewa rànja*, *pahomba rànja* or *ndewa luri* (see Chapter IV); for another aim of the ceremony is to request that the deceased be returned in the form of a living descendant or replacement (*hilu ngara*, see Chapter VII). The sleeping platform, being associated with sexual intercourse and conception, is thus specified in the liturgy as the place where this replacement should arrive, and is designated as the most firm and secure place of the soul. (In this case the soul is named with all six of the terms discussed in Chapter IV.)

At two noble funerals I attended, a similar rite was again held, in the house where the death took place (one other than the ancestral house), on the evening before the performance of a further ceremony 'to fetch the soul' (*piti hamangu*). The *piti hamangu* was then carried out in this same house on the day before the *bànjalú wai mata* ceremony. For this purpose, the metal bowl, betel container, knife, and riding horse of the deceased were taken to the house from the chief village where the dead person had been buried, and the first three items were placed in the right front corner of the building. Afterwards they were taken back to the chief village, where the *bànjalú wai mata* was to take place on the following day. These rites, which are evidently an elaboration of the simpler procedures followed by the lower classes, thus provide yet another indication that after burial the soul of the deceased retains a place among the living.

6. *Pahili Mbola*

As noted, the final ceremony, *pahili mbola*, marks the stage at which the deceased is completely assimilated into the land of the dead and the soul ceases to come and go between the afterworld and the house. This event is expressed with the phrases 'to reach the summit of red earth, to arrive at the end of the *mayela* tree'³⁷ (*lundungu la pinu tana rara, harangu la hupu ai mayela*), and 'to arrive at the collective and enduring village' (*lundungu la paraingu mapauli, paraingu mapatara*); and the deceased is exhorted to 'depart without looking back, to cross over without turning around' (*laku àmbi mbaili, pangga àmbi inggalu*). Here there is only enough space to indicate certain major features of the performance.

This is a collective ceremony held only once in a number of years, and concerns all the deceased of a single clan or several clans resident in the same or adjoining villages. I do not know whether it was ever performed simultaneously by all the clans in the domain.³⁸ The time of the performance is not meant to coincide with any stage in the decomposition of the corpse;³⁹ in fact, as on the one occasion I observed it, it can take place as early as eight days after the last burial. When this is done, the mourning period extends until the final ceremony, which thus indicates that the 'putting away of the tears' (*bànjalu wai mata*) represents a temporary suspension rather than an end of mourning. When the ceremony is held years afterwards, therefore, some days beforehand (eight by one reckoning) a rite called 'to bring near the tears, to make trickle the nasal mucus' (*pamareni wai mata, palulangu wai wira*) is held in order to summon the deceased souls to their houses. At this time the house is prepared in precisely the same way as during the period between burial and the termination of mourning. The metal bowl (*kaba julangu*) and red cloth are again brought out; the women resume placing betel, areca, and coconut products on the various tombs; and, among the nobility, a riding horse is again led daily to the graves. When several clans hold the rite simultaneously, women of each group visit the houses of all the other groups bringing with them betel and areca to offer to the deceased, in the right front corner of the building. In this way, I was told, the dead are afforded the opportunity of visiting among themselves during their final sojourn among the living. When the final day arrives, a pig and a buffalo are slaughtered for the clan ancestor and the deceased respectively. The offering also includes a number of fowls and an egg,

the latter being for those who died in childhood. Eight portions each of buffalo meat and rice are prepared in sixteen specially-made leaf cartons (*kolaku*), which are loosely plaited and have jagged edges. At the performance I attended, which (contrary to the normal custom) was held alone by a single lineage of the noble clan in Rindi, eight cartons (four of rice, four of meat) were sent to two commoner clans; when a number of clans hold the ceremony together, I was told, one half of the cartons are exchanged among the participating groups. The remaining eight are then placed atop coconut boughs laid out in the village square, and dedicated to the deceased by a priest, who faces towards the upstream end of the village, thus in the direction of the land of the dead. Afterwards he turns the cartons upside down. Since this act is in contrast to the usual practice when similar offerings are placed on the ground, it might thus be seen as an instance of inversion in respect of the dead. The rest of the buffalo carcass is then divided among members of the clan and invited affines. After the meal of pork is taken, among the nobility the riding horse, which on this occasion is decorated and saddled as during the funeral, is brought to the front of the house. A cry goes up among the women inside, and the animal is slapped to startle it. It is then allowed to run in the upstream direction before it is restrained and led back, an act which is intended to effect the final, irreversible, and speedy departure of the deceased souls. Later the betel containers of the dead are taken down from the inside wall and placed on the platform in the right front corner of the house. It is to this act that the name of the ceremony, *pahili mbola*, 'to take down the baskets', refers.⁴⁰ On the following morning the house and its contents are cleaned and the village square is swept. The refuse is then placed, with the betel containers and a quantity of betel and areca, metal chips, and rice on a large worn out mat. A dog and a cockerel (preferably a black bird, I was once told) are brought to the front of the mat, held to face upstream and slaughtered. The dog's carcass is then divided so that the right side with the head attached is placed at the front, and the other half at the back of the mat, an arrangement which thus accords with the association of the right with the front and left with the back demonstrated in Chapter I. The fowl serves as a food offering, while the dog's function is 'to haul the mat' (to the land of the dead).⁴¹ Neither is eaten. The mat is then dragged some distance outside the upstream gate and dumped.

7. Hot Death

The Rindi distinguish good and bad ⁴² deaths as cool and hot death (*meti maringu* and *meti mbana*) respectively. With regard to the former category, which is equated with death from illness, they say the deceased has been summoned by God (*paaungu Mawulu Tau*). Not all deaths of this sort, however, are entirely auspicious. Thus, while a youngster's death, for example, is considered in this respect to be cool, it is still normally regarded as a bad omen.

Hot death includes all forms of accidental or violent death, e.g., falling from a tree, being gored by a wild pig or buffalo, being constricted by a snake or caught by a crocodile, and death by fire, lightning, drowning, suicide, murder, or war. To suffer such a fate is described as *meti ànga*, 'to die in an improper, irregular way'; ⁴³ *kau meti ànga*, 'may you die improperly', is thus a form of imprecation. All deaths of this sort require special ritual treatment, which I shall describe just below.

The significant and distinctive features of hot death are suggested by several expressions by which it is designated, e.g., *meti harabàndangu*, 'sudden, violent death', ⁴⁴ and *meti nda pambutingu*, *nda pamomungu*, 'unexpected and unpredictable death'. Accidental death is also called *meti manjurangu*, 'unfortunate, unlucky death'. That the second word is apparently related to *njura*, 'back to front, upside down' (see Chapter XVI), suggests such a death to be in some sense an inversion of a norm. Accordingly, the phrase was explained to mean that the death is brought about by the victim's own actions and is his own fault, which relates to the widespread idea that accidental death is a punishment for transgression. (Cool death, however, can also be the result of transgression.) A victim of any sort of violent death is described as 'the one who died at the river and in the gully, in the mountain and on the plain, in the green forest and rock enclosure, the roaming death, the wandering death' (*na mameti la luku la kanjonga, la tandula la maràda, la uta muru la kaba watu, na meti njadangu na meti wenangu*). The phrases thus focus on the fact that this type of death characteristically (though not necessarily in every case) occurs outside the house and village; and this seems to indicate another significant difference from normal death. ⁴⁵ Related to this is the Rindi anxiety at the prospect of dying away from home, which they often give as the reason for not wishing to travel to foreign parts.

For the Rindi, bad death thus appears to be defined by a particular

combination of violence, abruptness, and unexpectedness, as well as its usual occurrence outside the house. It seems to be in these respects, moreover, that deaths of the sorts listed above are distinguished from death in childbed, death without apparent cause (*meti handàkangu*, 'to die at once'), and death from snakebite, which, though commonly spoken of as hot, are nevertheless treated in the normal way. Thus while death not preceded by apparent illness is also unanticipated, it clearly lacks the dramatic force of violent death, whereas death from childbirth or snakebite is very often comparatively slow; and in all three cases the person normally dies at home. Death from epidemic diseases resulting at once in a large number of fatalities (*meti tàparu* or *meti mbana tana*, 'death from the heat of the earth'), which is thought to be retribution from the *kawuu tana* spirits (see Chapter VI), is also described as a hot death; but there was disagreement as to whether it should be treated in the same way as violent death. That it might be probably follows in part from the practical necessity of quickly disposing of a large number of corpses. Where death is described as hot but is treated normally, therefore, the term seems to refer to its supposed ultimate causes (e.g., retribution for transgression) and its inauspicious nature rather than to its overt manifestations.

The fact that characteristically violent and abrupt deaths require special funerary procedures apparently involves the idea that the soul in such cases is suddenly wrenched from the body. For this reason, and because the death usually occurs outside the protective confines of the house, there is then a danger of it fleeing and becoming lost for good. By contrast, normal or cool death assumes a gradual separation of the soul from the earthly remains and the house, and its orderly transfer to the afterworld.

When the death involves the spilling of blood, an offering must first be made at the spot 'to ask pardon of the earth' (*pamalangungu tana*).⁴⁶ This is also intended to ensure that dangerous earth spirits and witches who are attracted by the blood do not follow the corpse when it is later taken to the house. For this purpose uncooked rice and an egg are given as 'that which cuts off' (*marata*). When it is brought to the house, the corpse, covered with a single cloth and bound in a flexed position, is laid out on the front verandah. Since both the body and the soul are considered hot, the corpse cannot be taken inside the house. The corpse, which is neither washed nor provided with a change of clothes, is then buried as quickly as

possible, in a 'sleeping position' (*pakatuda*) on its left side facing downstream in a newly excavated, rectangular grave.⁴⁷ A piece of rotan and a piece of lontar leaf, each three finger joints in length, are then placed in the grave 'to set a limit', i.e., to prevent such a death from being repeated.⁴⁸ Before burial (though I think it is sometimes postponed until shortly afterwards) an elder from a clan which holds the power of the 'hot cool water' (*wai maringu mbana*, see Chapter V, Section 4) is summoned to take the deceased's soul, for which service he receives a horse and two metal pendants (*mamuli*). After an offering is made to his special deity, the functionary leaves taking with him the betel container and knife of the deceased, by which means the deity of the *wai maringu mbana*, having the power to take unto himself all that is hot, receives the soul into his tutelage. In the rite, therefore, the dead man is called his 'child, descendant' (*ana*). Later the betel container and knife are placed in a special house consecrated to this figure.⁴⁹ After some indefinite time, but at least before *pahili mbola*, the dead man's agnates must go to this house to recover his accoutrements and hence his soul. After offering a fowl to the deity, they leave with the betel container and knife. Before the betel container can be hung in the deceased's own clan house with the others, however, it must be ritually cooled,⁵⁰ so that the soul can be introduced to the dead man's forbears and his clan ancestor, who prior to this, I was told, know nothing of the death. The soul is then taken by the earlier deceased of the clan to the land of the dead. While it is with the *wai maringu mbana*, therefore, the soul is in a sort of liminal state. The special procedures required for death by lightning and crocodiles, as well as that from certain forms of illness (*murū*), were mentioned in Chapter V.

While it is generally held that all classes of the dead enter the afterworld, before the soul is thus retrieved a special place is set aside there for those who die violently. The name of the place was once given as la Hambeli Luku Mbaku, Kiri Wai Langgara. Interestingly, in some parts of eastern Sumba the phrases *luku mbaku*, 'river of the erne', and *kiri wai langgara*, 'beginning of the whirling water', are names given to the Milky Way. Those who die in war, on the other hand, go to another place, called Dali la Au Bata, Ramuku Ndelangu Makatuburu. The second of these two phrases indicates a muddy pool. Witches, too, go to the land of the dead, but, significantly, are said to remain at a spot outside the principal village there.

8. Distinctions According to Age

The Rindi express age of death in an idiom of plant development. An elderly person's death is thus described as 'reddening (ripening) of the leaf spines, rotting of the roots' (*rara pàpa, mobu amu*).⁵¹ Someone who dies at an advanced age is also called 'a man who has arived, gone all the way' (*tau malundungu*),⁵² and it is said of him that 'he has reached his proper time (of death)' (*tomananyaka na rehina*). There is also the idea that a person should die at the same phase of the lunar month as that at which he was born, which thus suggests that a long life span is regarded as one that completes a cycle. This, of course, is the most auspicious sort of death. An adult who dies before this time is called 'paddy that has fallen while still green, areca that has broken at the top' (*pari n̄joru muru, winu mbata dita*), while the death of a child is described with the phrases 'broken in the growth, pulled up as a sprout' (*pata tumbu, buta ngora*). Infants who die before weaning and stillbirths, on the other hand, are both called 'fallen blossom, split *mata*' (*munju wàla, mbera mata*).⁵³

Although the death of a young adult is usually considered inauspicious, it does not differ in manner of treatment from an elderly person's death.⁵⁴ The death of a weaned child is treated in essentially the same way, though the procedure is somewhat attenuated: a single horse is slaughtered and only the closest affines are invited. It is optional whether the dead child is provided with a betel container and knife; if this is done, both will be smaller replicas of the adults' possessions.

If a child dies before weaning, however, there is a special procedure.⁵⁵ Though I never saw it performed, a priest who had recently officiated at the funeral of his young granddaughter gave me a detailed account of it. The corpse should be kept no longer than one night in the house. It is first placed in a flexed position and wrapped in just three thin red cloths bound with a white thread.⁵⁶ The corpse is then laid on its left side in the right front corner of the house facing out towards the village square. Two metal coins are folded into the child's left hand. One is a prestation for the child's grandparents (or ancestors, *umbu-àpu*), who will care for him in the afterworld; the other is to exchange for milk. In the right hand they place a boiled chicken's egg and some cooked rice. The rice is a provision for the journey to the land of the dead. While he remains outside the chief village in the afterworld, the child goes each day to play with

the egg in the waters of a nearby pond at a place called Katiku Tàma, Rindi Málatu.⁵⁷ This he will do until he reaches maturity, at which time, with his grandparents, he becomes fully assimilated into the village of the dead. Before burial the priest addresses the dead child exhorting him not to misbehave while in the care of his grandparents or to pine for his mother and father. It is a moving speech. Women mourn over the corpse for a time before the child's father carries it to the grave. The mother then expresses milk onto the stone, from her right or left breast according to whether it is a boy or a girl. While a small pig may be slaughtered, there are no further rites. Affines are not especially invited and there is no exchange of prestations.

With stillbirths, by contrast, burial is simply a means of disposing of the corpse. This is done immediately, at night if this is when the birth occurs, by inserting the corpse with the placenta and umbilical cord through a hole dug at the back edge of an existing grave. Any grave can be used. Stillborn infants, I was told, do not have a soul and therefore do not go to the land of the dead. In fact, they were once said not to be human. It is significant, then, that what apparently distinguishes a stillbirth from an unweaned child in respect of the funerary custom to be followed is the former's lack of a name. I never encountered the idea that a stillborn child is reborn when its mother again gives birth.

If we discount stillbirths, therefore, there are just two classes of mortuary practices distinguished according to the age of the deceased in Rindi: one for adults and older children and another for unweaned infants. In both instances the soul is believed eventually to enter the land of the dead, though in the latter case it does so under the auspices of previously deceased adults. The unweaned child's dependence on his forbears in the afterworld thus parallels his dependence on his mother during his short life.

9. Distinctions According to Rank

While funerals of commoners and slaves differ mainly with regard to the scale of expenditure, which simply depends on the wealth of the deceased's agnates, noble funerals are distinguished by certain special usages. One of these, the use of a decorated horse, has already been mentioned. Nowadays it is optional, in the case of the lesser nobility at any rate, whether the more elaborate procedures I shall briefly outline are adopted. As none of the funerals I attended

included them, I must therefore rely on informants' descriptions.

For deceased persons of the highest nobility a structure (*kawarungu*) of wood and thatch, closely resembling a house, is erected over the grave after burial. This is to accommodate the specially costumed functionaries (*papanggangu*) who are assigned to attend the deceased. It is built according to the rule 'proceed to the left' (*palua kalaingu*), hence in the opposite manner to that required for other buildings (see Chapter I), and faces in the same direction as the grave, i.e., towards the sunset. The deceased's principal wife-givers are responsible for its construction. While traditionally the *kawarungu* was built atop the stone that covered the grave cavity, and so served as a temporary shelter for the grave until a top stone (resting atop four or six pillars) could be obtained, more recently it has also become the practice to erect the structure over the entire, completed tomb. Contrary to the practice elsewhere in eastern Sumba (see Kapita 1976a:172), I was assured that in Rindi the corpse is interred before the shelter is built; it is never placed in a chest inside the shelter as is done elsewhere.

The Rindi say that originally a *kawarungu* stood for sixteen days before it was disassembled. The final *pahili mbola* ceremony for all the deceased of the clan was then held a further eight or sixteen days afterwards; so when a *kawarungu* is provided, the rite which marks the suspension of mourning (*bânjalu wai mata*) is not carried out. The nobility thus normally do not perform *pahili mbola* until such times as a *kawarungu* has been erected and disassembled for a dead man of the highest rank. In more recent times, however, the formal removal of the shelter (*nyanggaru kawarungu*) has often been delayed for years, and it has been left to delapidate.⁵⁸ Properly speaking, the attendants of the deceased should remain continuously inside the shelter until it is taken down; otherwise they do so until it falls into disrepair.⁵⁹ So long as the *kawarungu* is still standing, the men play the gongs and drums and sing the special mortuary chants each night, and periodically they slaughter livestock for the deceased. As the gongs and drums, along with the dead person's betel container and knife and the metal bowl (*kaba julangu*), are kept inside the *kawarungu*, the shelter thus replaces the right front corner of the house as the place of the deceased's soul after burial; and the duration of its existence is conterminous with the transitional period during which the soul occupies an intermediate position between the world of the living and the afterworld. The eight or sixteen day interval after the *kawarungu* is taken down, therefore, evidently represents the time

required to assemble the deceased souls of the clan for the *pahili mbola* ceremony. During this time, the costumed attendants return to the right front corner of the clan's ancestral house, where they remain until the final rite. The removal of the shelter also provides an occasion for completing the exchange of funerary prestations which will have begun on the burial day. As noted, an additional exchange takes place at the time of the *pahili mbola* itself.

The number of costumed attendants (*papanggangu*), who are selected from among the slaves of the noble clan or lower ranking commoners, varies between two and six in Rindi. The number employed accords mainly with the deceased's rank, though I was told a young adult, whatever his rank, would receive no more than four.⁶⁰ The different functions the attendants are assigned are hierarchically ordered and distinguished or combined according to the number of persons employed. Each male functionary has a female counterpart; so there is always an equal number of men and women. When six attendants are used, they are distinguished as follows (here listed in pairs of men and women, in order of precedence): the rider (*makaliti njara*), a man who rides the previously mentioned mount of the deceased whenever it is led to the grave; the 'one who wears the hat' (*matidungu tubuku*), a woman who wears a tall conical hat covered with a red veil; the 'fowl bearer' (*malunggu manu*), a man who carries a (preferably red) cockerel under his left arm; the 'holder of the woman's betel basket' (*mayutu kàpu*), a woman; the 'bearer of the man's betel purse' (*mahalili kalumbutu*), a man; and, finally, the 'betel pounder' (*matanggu tuku*), a woman whose task is to crush the betel and areca to be offered to the deceased. There is not enough space here to describe the costumes and decoration of the *papanggangu*, but only to mention that they are more or less elaborated according to the functionary's rank, as indicated by the sequence in which they are listed above. The same ritual tasks are assigned to the attendants regardless of the sex of the deceased. The metal bowl (*kaba julangu*) is not carried to the grave by the *papanggangu*, but by another woman of slave rank.

While no one in Rindi could explain the significance of the cockerel carried to the grave, it seems fairly clear that it is related to the general custom, whenever a new grave is dug, of placing a small chick at the centre of the area to be excavated so that it will scratch the earth. Afterwards, the bird, called the 'chicken that sweeps the grave' (*manu kanjeku reti*), is left tied to a small stake close to the grave, preferably,

I was told, to be trampled on and killed during the burial, though this is not done deliberately. On no account may the bird be kept and raised, for it belongs to the dead and is therefore considered hot. Since Kapita (1976a:160, 178) states that the cockerel carried by the *papanggangu* in eastern Sumba is called by the similar designation *manu ramba reti*, 'fowl that clears the grave', it seems, then, that this bird may be conceived as a replacement or representation of the chick. Even so, the Rindi assured me that the cockerel is not called *manu kanjeku reti* or anything similar.

The female attendant who wears the hat and veil closely resembles the substitute bride used in the highest form of marriage and hence, as I shall later elaborate, the enshrouded corpse itself (see Chapter XVIII). She is regarded as the most important of the female *papanggangu*. Thus if only two attendants are employed it is this woman who undertakes the other female tasks as well, while the rider, her male counterpart, also carries the man's betel purse. The function of bearing the cockerel is then omitted all together.

The attendants are first costumed on the burial day, when they are seated next to the corpse in the house. Later they follow the corpse to the grave, at which point, if not before, they are likely to lose consciousness (*meti widi*).⁶¹ Arriving at the grave, the attendants are seated on mats placed around the cavity; one of the names by which they are known is thus *mangadu lambongu*, 'those who look down into the hole'. As the term *papanggangu* derives from *pangga*, 'to step, cross over', 'to walk', Kapita (1976a:158) glosses it as 'those who are assisted to walk', referring to the fact that, as they fall into a trance, they must be helped to the grave. According to another interpretation, suggested by Rindi informants, however, the term might alternatively be translated as 'those who are made to cross over, transferred', which would then agree with the idea that the functionaries, or their souls, accompany the soul of the deceased to the afterworld. The *papanggangu* are thought to enter the world of the dead while they are unconscious; and when they awake they are often able to report their experiences in the afterworld and to communicate the wishes of the deceased — which must be fulfilled — to the living. During the period of their ritual employment, the *papanggangu* are thus in a transitional state analogous to the mortuary condition of the dead man himself, hence they must be treated with great respect. While they occupy the *kawarungu*, they have the right to request animals and foodstuffs (*mangapangu*, see Chapter VIII, Section 3)

for their needs from the other residents of the domain, and they cannot be refused. The requests are made, I was told, in the name of the deceased nobleman himself.

That the *papanggangu* are transferred to the realm of the dead finds further expression in the custom of wearing their clothes and hair according to the rule 'to move to the left', in the same way as the corpse. The men also carry their knives and betel purses on the right and left respectively, in the manner opposite to that of the living. Indeed, at least some of the attendants appear to represent the soul of the dead man himself; this is particularly suggested in the case of the rider, the principal *papanggangu*, since the horse he rides is also spoken of as the mount of the deceased.

After the burial, the *papanggangu* enter the *kawarungu* or, if such a structure is not erected, they return to the house, where they remain until the suspension of mourning (*bànjalu wai mata*). In the latter case, twice a day during the interval they proceed to the grave with the women who place the usual offering of betel, areca, and coconut products on the stone. As noted, when a *kawarungu* is built, they re-enter the house only after the structure is disassembled, and remain there until *pahili mbola*. In return for their services the attendants keep the special clothing they wear, and slave women who act in this capacity cannot later be alienated from the noble clan, e.g., through marriage. But although they are afterwards treated with special respect and affection by their masters, slaves employed as *papanggangu* in Rindi do not become free, as de Roo (1890:584) claims.⁶²

As noted, another funerary usage exclusive to the nobility in Rindi (though apparently not in all parts of eastern Sumba) is the playing of gongs and drums. In Rindi, moreover, the instruments are played only when *papanggangu* are employed. In former times, it was also the custom to fire guns and cannons at noble funerals, a practice mentioned for eastern Sumba by Roos (1872:56). As with the other special funerary customs of the nobles, however, these usages indicate no more than an elaboration of certain themes common to all funerals, and not any systematic difference in ideology concerning death or the fate of the dead between the social classes.

10. *An Interpretation of Mortuary Symbolism*

For the Rindi and the inhabitants of neighbouring domains, the land (or village) of the dead (*parai marapu*) is located in a wooded

mountainous region in the interior district of Mahu, close to the headwaters of the major rivers. As is common in Indonesia, this land, which is sometimes seen in dreams, is believed to parallel the world of the living but to be far more affluent. Everything there is clean, new, and finely proportioned, and the dead want for nothing. The souls of the dead assume the same form as their bodies in life. The society of the dead, too, is thought to reflect that of the living; thus nobility remain nobility and slaves remain slaves.⁶³

The afterworld, however, is distinguished from the mortal world in certain ways which bear significantly on ritual practice. I have illustrated the extensive use of lateral inversion in mortuary customs. This is rationalized by the idea that the world of the living and that of the dead are governed respectively by the opposed rules 'to move to the right' (*palua kawanangu*) and 'to move to the left' (*palua kalaingu*). Lateral relations among the dead are thus ordered inversely to those which obtain among the living: the dead are without exception left-handed; they arrange their clothes and hair 'to the left'; the superior, male side of the house (*kaheli bokulu*) is placed on the left; and so on. Clearly, therefore, the rule of *palua kalaingu* in funerary usages is aimed at integrating the deceased into the society of the dead.

Inversion is further instanced by the idea that the houses of the dead in the afterworld, in contrast to those of the living, all face towards the sunset. This agrees, then, with the orientation of graves in the village and the related notion that the land of the dead itself lies (roughly) in this direction. Rindi ideas do not accord with Perry's (1914:286) claim that in Indonesia the afterworld is generally identified with the place or direction from which the ancestors came. Indeed, as I remarked earlier, the land of the dead is located in the vicinity of the Head of the Earth, which lies in the opposite direction from the place of origin of the first ancestors, which is the Base of the Sky. That the dead are associated with the setting sun, therefore, seems to be based on the analogy between a person's life and the daily course of the sun. It can also be inferred from various particulars that night and day are inverted among the dead, which accords with the general notion that spirits of all sorts are most active at night time. Apart from these ideas, however, I discovered no other clear indications of inversion among the dead. Certainly the theme is not so elaborated as in Central Celebes, where the living and the dead are similarly distinguished by their respective associations with right

and left (see Kruyt 1973:74-91). It is thus lateral inversion in particular, with regard to both position and direction, that is the prominent idea in Rindi.

In the context of the funeral, *palua kalaingu* was once said to mean 'to return, go home' (*beli*). As noted in Chapter I, the contrasting order, *palua kawanangu*, involves a conceptual movement from a trunk or source (*pingi*) to a tip (*kapuka*); thus *palua kalaingu* logically entails a movement from a tip to a source. Indeed, that death is a return to a point of origin is a very prevalent idea in Rindi. A dead person is thus said to have 'gone to the one who made and plaited him' (*luananyaka la mawulu la majiyya*), i.e., to the Divinity and the first ancestors. The idea of returning to a source, however, can be understood to refer to a cyclical process as well as to a reversal of direction. In fact, both ideas are discernible in Rindi representations, though the notion of cyclical development evidently refers mainly to the soul, and that of reversal to the body or, perhaps better said, the deceased's earthly form.

One expression for death which appears to reflect this duality is 'to enter the earth, to ascend to the sky' (*tama la tana, hei la awangu*). I noted earlier that development in life is often represented as an ascent. Accordingly, since physical death is in obvious respects a reversal of this process, it is often spoken of as a fall. This is shown by the following phrases, which refer respectively to the death of a man, a woman, and a noble person: 'falling of the horse, breaking of the crest' (*njoru njara, mbata landu*); 'falling (collapsing) of the hearth, splitting of the water jar' (*njoru au, mbera mbalu*); and 'falling of the great tree, splitting of the big stone' (*njoru ai pabangga, mbera watu bokulu*).⁶⁴ Death is also spoken of as a 'slipping from the lap and arm' (*taruhuku la baba, manggomalu la lima*), which alludes to the protection afforded to the living by the ancestors. The idea of destruction (i.e., breaking and splitting), which is also prominent in the above phrases, is reminiscent of the practice of destroying the outward, material form of an object in order to facilitate its transfer to the afterworld.

The idea of reversal is further suggested by certain usages that indicate death to be analogous to a return to the womb. That the disposition of the corpse in the grave is the inverse of that of a child emerging from the womb seems pertinent here. Indeed, the Rindi describe the squatting posture of the corpse as like that of a fetus, and they use one expression, *mbola kati, mbola iwi*, 'basket of herbs,

basket of rotan', to refer both to the uterus and to the grave.⁶⁵ In addition, the dead man is said to 'have returned to the melting pan, gone to the creation stone' (*beli la kaba lala, lua la watu wulu*), which phrases, as noted, designate the womb and the male genitalia; while the name of the place where the deceased enters the land of the dead, *pindu nda kalewa, talora nda malai*, 'the gate that is not wide, the village square that is not long', was said to refer as well to the female genitalia and the womb. There are also several passages in liturgical speech that suggest the deceased to be like a small child. Thus he is admonished not to err in the laps of his deceased grandparents (or ancestors), and they are requested to receive him well into their laps and arms. The Rindi do not say, however, that the dead enter the afterworld as children; so perhaps these idioms express no more than the analogy between the relation of ancestors and descendants and that of parents and children. But whatever the case, it is clear that death is thought to resemble birth, which suggests the notion of death as a rebirth or initiation (see Hertz 1960:80). In this regard, then, rather than a reversal, death represents a further stage in the cycle of development. Since it is a culmination which stands opposed to birth, and hence to life, however, in most respects the two are viewed as antipathetic. The cycle is closed only when the deceased is later returned to the living as renewed life.

The Rindi articulate the cyclical relation of life and death in several ways. Briefly, the basic idea is that all life-giving essence — 'what is piled up in the leaves, inserted in the fruit' (*na patawangu la runa, na paunungu la wuana*) or 'the liquid of fecundity and prolificity, the fatty and greasy liquid' (*wai woru wai bàba, wai kambombu wai malala*) — derives from the dead, and so is the means by which the dead are returned to the living. In part, this essence is identified with the deceased's body fluids which directly enter the earth. Thus the former rule of burial within four or eight days was said to have been aimed at preventing the earth from becoming dry and lifeless. A complementary idea is that the vital essence derives from upstream, the direction of the land of the dead, in the form of rain and river water. By way of the water it then enters crops and from there the bodies of men and women whose intercourse produces the living replacements (*hilu*) of the dead.⁶⁶ The deceased's bodily fluids, the spirit of the dead, the essence of food crops (which is similarly identified with their 'oil' and 'fat'), and reproductive power are thus all symbolically equivalent. An important difference mentioned in Rindi between the

living and the dead was that the latter do not produce offspring. Were they to do so, I was told, they would need to retain for themselves all that they provide to the living.

According to one specific formulation, the deceased in the afterworld, having no firm place there, are eventually washed downstream and out to sea by floods.⁶⁷ This is evidently connected with the idea that after some time the soul (*hamangu*) dies in the land of the dead, whereupon the remaining spirit (*ndewa*) becomes reunited with God, or becomes *marapu* (see Chapter V). Just before the wet season, what remains of the dead is swept up from the sea into the sky to become mist (*wai kàmbangu hambongu*). The mist is then carried back upstream by the wind where it becomes rain, specifically the cool rain that follows the course of the river (*ura tundu luku, wai maringu*), which fertilizes and nourishes the crops. Since the dead immediately after burial also travel downstream to the estuary before turning upstream towards the land of the dead, this process thus involves the completion of a double cycle defined with reference to the two extremities of the river, which produces a radical transformation of the deceased into life-giving spirit. Essentially this is a transformation of something hot, i.e., both the corpse and, initially, the dead soul, into something cool. Thus the waters of the sea and the estuary, to where all forms of 'heat' (*mambana*) are removed (see Chapter III), must be carried upstream as mist before they can become cool, salutary rain.⁶⁸ That the souls of the dead must undergo such a transmutation before they can return to this world is thus in accord with the view which some Rindi expressed that, while in other respects the two individuals are identified, the soul (*hamangu*) of a new born child is not exactly that of the ancestor whose name he receives, but a new soul made by God. The ascent of what remains of the dead to the sky in the form of mist, then, is apparently equivalent to the return of the spirit (*ndewa*) to God.

The cyclical relation of life and death is further reflected in the route the soul follows to reach the land of the dead. Although the several versions I obtained differ in detail, they nevertheless convey the same general impression. The lengthy itineraries comprise a host of proper names and descriptions of places arranged, as is the general practice, in sets of two or four. The longest I recorded included nearly fifty pairs of phrases, most of which denote mainly uninhabited locations on Sumba. I shall briefly outline one of the more elaborate versions of the itinerary (see Fig. 5). After leaving the house, the soul

follows the course of the river Rindi until it reaches the estuary. It then turns northwards, travelling along the coast until it arrives at the mouth of the Kambaniru river, where the first ancestors landed on Sumba, and from there journeys to the Base of the Sky, which, as noted, is identified with the horizon.⁶⁹ In this way, then, the soul retraces the route of the first clan ancestors. Indeed, the more elaborate versions of the route of the soul closely correspond to the journey of the ancestor (*marapu*) recited in certain major rites, which

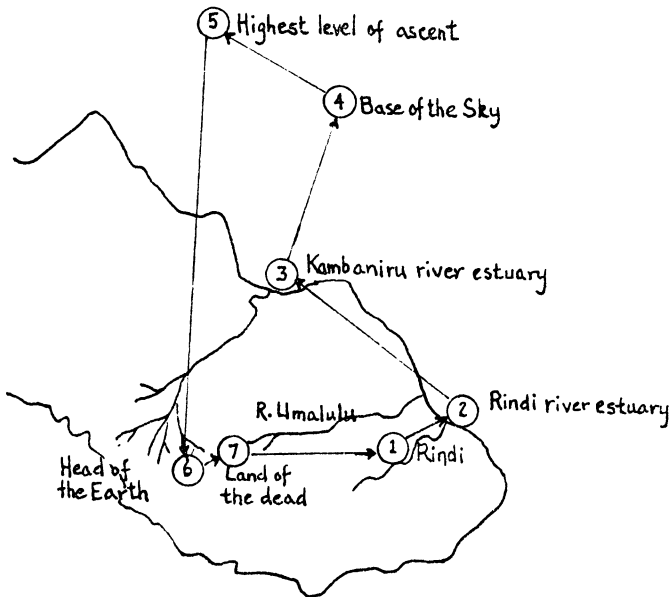

FIG. 5. Simplified Representation of One Version of the Journey of the Soul

he makes when transferring messages between mankind and the Divinity; this, however, does not include the land of the dead. Upon reaching the horizon, the soul scales a ladder with four rungs. The places named along the way (which there is not enough space to list here) refer both to these rungs and to the various levels of earth and sky.⁷⁰ After reaching the highest level, the soul descends by another ladder, also with four rungs, to the Head of the Earth, which is further identified with the names of locations in Tabundungu and Mahu, and from there proceeds to the land of the dead. In the context

of the mortuary ceremonies, this place is the soul's final destination; but in this and another longer version of the journey I recorded, the list continues, describing a route that follows the downstream course of the river to the house, where the journey began. In this way, then, the Rindi apparently anticipate the eventual return of the deceased's spirit to the realm of the living; so the entire journey is cyclical.

According to the version of the soul's journey I recorded at the *pahili mbola* ceremony, upon returning to the house (i.e., the clan's ancestral house) it finally ascends to the peak, the place of the ancestral spirit (*marapu*). Clearly, then, this accords with the idea that the deceased in the end returns to God and becomes *marapu*. I also mentioned that the *hariangu*, the ladder-like structure placed behind the corpse before burial, is supposed to facilitate the soul's ascent to God. Interestingly, I was once told that by way of this structure the soul climbs up to the house peak. As noted just above, it is by means of a similar ladder at the Base of the Sky (or the horizon) that the soul travels up to the heavens before descending to the Head of the Earth.⁷¹ This is consistent with another idea I encountered in Rindi, namely that on death the soul ascends to *mawulu tau*, 'the creator of men' (which as noted can refer both to God and the clan ancestor) and then later descends to the land of the dead. In this context, therefore, the peak of the house and the place of God (or the clan ancestor) appear to be symbolically equivalent, so that the three ascents are different expressions of the same fundamental idea. It is relevant, then, that the *hariangu*, the ladder at the Base of the Sky, and that which provides access to the peak of the house each have four rungs. Since the three ascents are sequentially distinguished, however, one can discern, in another dimension, a double cycle similar to that defined with reference to the upstream and downstream extremities of the river.

As is concordant with the association of the dead with the left and the living with the right, Rindi mortuary customs manifest a feminine aspect of the dead. That the dead are symbolically feminine is most clearly expressed in the Rindi idea that when the soul is taken to the afterworld by the deceased's forbears, it is ritually incorporated there in precisely the same way as a bride, when (in the most elaborate form of the marriage ceremony) she is brought by the wife-takers into her husband's village. This applies whether the deceased is male or female. In ritual, the idea is reflected by an arresting resemblance between a corpse prepared for burial and a bride's substitute just

before she is taken from the wife-giver's house (see Chapter XVIII): both assume the same position, sitting motionless in the right front corner of the house; the heads of both are veiled in red cloth; both are attended by women who weep and perform exhortatory chants in anticipation of the addressee's departure; and both are carried from the house by men while the women attempt to hinder their passage. These parallels also shed light on the significance of the female attendants of a noble corpse, particularly the one who wears a veiled hat; for a bride's substitute also wears such a hat beneath her veil.

It is in accordance with these resemblances that, as I have shown, it is the women who play the prominent role in funerary rites, and one not dissimilar to, though much more elaborate than, that which they play at marriage. That in doing so they come to occupy the right section of the house, from which they are normally excluded, provides another instance of inversion in mortuary customs, as indeed does the ceremonially active role of women itself. In a sense, therefore, the right half becomes the feminine part of the house, which agrees with the idea that in the land of the dead the masculine section is placed on the left. It seems implicit in this, moreover, that while the masculine is superior in life, the feminine is superior in death; thus while both the world of the living and that of the dead contain males and females, the former is categorically masculine and the latter categorically feminine. Accordingly, the transfer of the dead to the afterworld is ceremonially accomplished in the same way as the one instance of an irreversible ritual transfer that exclusively concerns a woman, namely her marriage. As Hertz (1960:80) noted, death, like a woman's marriage, involves a 'double change of status', in the latter case from the class of unmarried women and from one clan and community to another.⁷² It is an open question whether marriage rites are the model of funerary rites in Rindi or vice-versa; but whatever the case it is useful to recall Hertz's remark that '... death is not originally conceived as a unique event without any analogue' (1960:81).

The Rindi say that after death a woman marries her *layia mini* (HZH, etc.) and a man his *yera kawini* (WBW, etc.). Since in life these relatives are subject to a strict rule of avoidance, and marriage between them is prohibited, the idea might be taken as another expression of inversion. It is relevant, then, that correct marriage is counted as an instance of 'movement to the right'; so a union of this

sort could be interpreted as a 'movement to the left'. The idea that the dead should marry in this way also fits with the Rindi expectation that incorrect marriages will be infertile.⁷³ Yet it is not clear why they do not say that a dead man marries his FZD, since according to their rules of marriage this would provide a rather more striking instance of inversion. (WBW is not classified with FZD in Rindi.) We should consider, however, that the similar treatment accorded to a dead person and a bride entails a symbolic equivalence between the community of the dead and wife-takers, who the Rindi regard as feminine affines and who in another sense are similarly takers of life (see Chapter XIII).⁷⁴ Perhaps, therefore, the idea focuses on the fact that by marrying her HZH a dead woman is taken as a wife by her (living) husband's wife-takers.

Of course, by virtue of the idea that life ultimately derives from the dead, the souls of the deceased might also be said to resemble wife-givers (see my remarks concerning the Head of the Earth in Chapter III). But as I have shown, this concerns another, more advanced stage in the transformation of the soul or spirit. These two aspects of the dead are reconciled by a cyclical representation of the relation between life and death. The transformation of the dead into living spirit can therefore be compared to the system of asymmetric marriage, whereby the reproductive capacity that leaves the group with its natal women can in principle be recovered only by means of intervening marriage links. The spirit of the dead as a moveable element circulating through a number of lives thus resembles the ultimately cyclical transfer of women between groups entailed in this sort of marriage system. Hence, by means of this analogy, we are afforded a deeper insight into the symbolic femininity of the dead.

The colour red (*rara*) has been shown to have a prominent place in Rindi funerary symbolism. This accords with the close association of this colour with the land of the dead, described as the 'summit of red earth' (*pinu tana rara*);⁷⁵ thus the Rindi explain the use of red at the funeral as a way of identifying various items (e.g., the horses slaughtered) as belonging to the deceased, in order to ensure their admittance, with the dead man himself, into the afterworld. The soul of the deceased is said to ride to the land of the dead on a red horse, and, upon entry, itself to become red.⁷⁶ More generally, chicken's entrails that are particularly red (i.e., bloody) augur death; hence they are usually a bad omen, except in certain contexts, such as cursing or war ritual, where death is the desired objective.

Red is not exclusively associated with death in Rindi, for by virtue of the similar treatment of a corpse and a bride noted just above, it is also encountered in marriage rites. Both ritual contexts, however, involve major transitions, and it is here, I suggest, that the significance of red may be found. This connexion is further suggested by the designation of the moon at its fullest as *tambulu rara*, 'red full moon', as this phase marks the transition between the waxing and waning halves of the lunar month, which the Rindi associate with life and death respectively; and as mentioned in Chapter VII, there also appears to be a link between the category *rara* and pregnancy. One clue to the appropriateness of red in these contexts is that the word *rara*, 'red', has the further senses of 'ripe, overripe', 'mature, old', 'desiccated', and, indeed, 'dead'. In this respect, then, it is evidently opposed to *murū*, the word for 'green' and 'blue', which refers, among other things, to immaturity and undevelopment (see Chapter VI).

The opposition of red and white may also be significant here. In this case red is associated with menstrual blood and gold, in contrast to semen and silver; and the two metals, distinguished as 'red' and 'white' metal, are further linked with the sun and the moon. In addition, red seems generally to be connected with things considered hot, and white with coolness. Thus in some contexts the latter colour connotes purity and newness,⁷⁷ while red is associated with danger and defilement. Accordingly, the practice of tying a red 'flag' (*penji*) to a stake at the front of a large gravestone when it is hauled to the village was said to signify the (often very real) danger involved in the operation and to serve as a warning to bystanders to keep clear. But it is also pertinent that the stone is ritually treated as a bride when she is transferred to her husband's village, while other usages clearly show it to be identified with the dead person for whom it is intended. Like a woman's marriage and the funeral itself, therefore, the hauling of a gravestone entails an important transition. A connotation of danger is also found in the rule forbidding planting at the time of the fullest 'red' moon (or when the moon is not visible, a phase called *meti wulangu*, 'death of the moon'); for if this were done the crop would fail. As noted, menstrual blood has the same deleterious effect on plants. Yet menstrual blood is also thought necessary to conception.

As I have shown, red is generally the preferred colour for fowls slaughtered for the clan ancestor, the entrails of which serve as an augury.⁷⁸ Arguably, this has less to do with transition than with

articulation and mediation; but transition is present nevertheless in the explicit idea that the chicken carries messages back and forth between humanity and the ancestor, and in so doing undergoes a fundamental change of state, which is effected by its death. To attempt to read the entrails of a bird that has not been dedicated is thus a pointless endeavour; and the Rindi will not do so. As pigs slaughtered for the ancestor are preferably black, this interpretation cannot be applied to other sacrificial animals. But since, as I noted in the last chapter, black in some contexts appears to symbolize the completion of a transition, or a disconnexion, it seems significant that a large animal such as a pig is always the last of a series of sacrifices; and large animals are never slaughtered without one or more chickens.

In certain instances, therefore, red is symbolic of what is antithetical to life, while in others it is associated with the opposite values. With regard to its varied meanings, which largely derive from the fact that it can stand in opposition to black, white, or green/blue (*muru*), the symbolism of this colour in Rindi is thus somewhat reminiscent of that found among the Ndembu, where it is contextually linked with both continuity and discontinuity, prosperity and danger, and with life and death (Turner 1967:70, 80). In this respect, moreover, the symbolism of red seems closely to parallel the varying significance of blood, with which the colour often, if not invariably, appears to be linked. Thus while the appearance of blood often signals danger and disconnexion, blood in Rindi is also a property that is transferred from wife-givers to wife-takers and constitutes their vital connexion (see Chapter XIII). As a symbol of transition, therefore, red similarly entails both disconnexion and connexion; and since these two qualities are sometimes represented by black and white respectively, red can be seen to combine the contrasted values symbolized by these two colours separately. While red expresses transition, moreover, black appears to signify, specifically, the completion of a transition. As I have shown, in transition rites this contrast corresponds to an opposition between a marginal, spiritual state and a return to the temporal order; and it is perhaps relevant, therefore, that in two contexts where red is paired with black, the former was expressly stated to be masculine and the latter feminine (see Chapter VI). (The gender associations of red in contrast to white, on the other hand, are inconsistently attributed.) Mortuary rites, especially the earlier stages of the funeral where red is most conspicuous, however, are rather more concerned with the separation of the dead from the

living than with continuity, which is associated with white. Thus, with regard to funerary prestations, black is considered an appropriate colour whereas white is not. In addition, though the use of black is not enjoined in this context, it was said to be the preferred colour for the bird slaughtered in the final rite of the *pahili mbola* ceremony, which marks the definitive departure of the souls of the deceased from the living.

11. *The Symbolism of Numbers*

Finally, it is useful to summarize the data concerning the symbolism of numbers given in this and the two previous chapters. As I have shown, where numbers are important it is generally even totals that are prescribed. One exception to this is the rule that the corpse of an unweaned infant should be wrapped in three cloths. Since odd numbers signify incompleteness, the practice thus seems to express the incompleteness of the child's brief life.⁷⁹ This appears also to be the significance of the requirement that the cloths, in contrast to those used for an adult, be thin, and, regarding what I said just above about colours, the fact that the thread used to bind them is white. These customs indicate, then, a deliberate impoverishment of the adult funeral. The other appearance of uneven numbers in mortuary usages concerns the pieces of lontar leaf and rotan, each three finger joints in length, which are buried with someone who has died a hot death. Though the items are expressly said to serve as a boundary or limit, it should be recalled that a life ended in this way, too, is regarded as premature and hence incomplete.

Even numbers, especially four, eight, and sixteen, on the other hand, are prevalent in all stages of the life cycle, and particularly in the sequential arrangement of linked performances entailed in each stage. Thus a mother's first bath after parturition and several rites expressing separation and incorporation take place eight days after birth, and it is said that in order to wean a child it must be separated from its mother for eight days. The youths' initiation ceremony, which requires an even number of participants, involves a period of seclusion of four or eight days. The final mortuary ceremony is held at the earliest eight days after the funeral, and when it is performed much later, the souls of the deceased are summoned eight days before the ceremony. When a shelter is erected over a nobleman's grave, moreover, this should stand for sixteen days; and the final cere-

mony is then held eight or sixteen days after it is taken down.

I have remarked that even numbers are generally considered auspicious. Related to this is the rule that appointed times, e.g., for meetings between affines, should always be set at an even number of days in the future, the preferred numbers again being four and eight. As odd numbers are generally inauspicious, an uneven number of days would not bode well for the undertaking. In the cases listed above, however, the relevant attribute of even numbers seems to be not so much their auspiciousness as their completeness. The total number of days in each case can thus be seen to constitute a unitary period which is necessary to complete a transition. As I noted with regard to the eight-day period preceding the final mortuary ceremony, for example, this is evidently the time it takes to assemble the deceased souls from the land of the dead. Even numbers, therefore, can also be seen to manifest an association with *points* of transition, the eighth (or fourth, etc.) day in each instance being the juncture at which a transition is completed. The number four, especially, is similarly associated with transition in Kédang (Barnes 1974:168).

Considering the preponderance of even numbers in relation to temporal arrangements, it might seem somewhat anomalous that the rite marking the suspension of mourning should take place three days after burial. Since the Rindi express this as 'four days including the burial day', however, they evidently think of the two ritually important days plus the two intervening days as forming together a complete unit, so that the symbolically important number in this case, too, is actually four. This is further shown by the fact that the rite is held after the corpse has already been in the grave for three nights; thus the deceased's betel container is hung on the wall on the fourth night.

From the fact that even numbers in Rindi are linked with points of transition, it might be inferred that uneven numbers are associated with the sections or periods between these, and hence with duration, as Barnes (1974) shows to be the case in Kédang.⁸⁰ In general, however, the Rindi do not consciously articulate this association; and as I have noted, rules enjoining uneven numbers are rare. Accordingly, such numbers are not conclusively revealed in ideas concerning fixed and recurring periods of time such as the year, the month, and the day in Rindi.⁸¹ Indeed, apart from the fact that these units each comprise two major named parts (e.g., the wet and dry seasons of the year and the waning and waxing halves of the lunar month),

I found little evidence of recognized totals at all in this regard. The passage of the year, for example, is marked by a series of named rains, winds, and other natural phenomena of a regular annual occurrence, and there are a great many terms denoting times of day and night and the phases of the moon. But as the Rindi could not immediately say how many members there were in a given series, the totals are apparently of little symbolic importance. Furthermore, other things implicitly linked with transition do not comprise an uneven number of parts. The ladder connecting the lower and upper sections of the house, for example, has four or eight rungs, and the universe is composed of eight levels of sky and earth. (In these respects, also, Rindi appears to contrast with Kédang; see Barnes 1974:76, 168.)

As promised in the first chapter, I shall now describe two usages which reveal an association of odd numbers with life and even numbers with death.⁸² In this case, as well, the two sorts of numbers are expressly linked with completeness and incompleteness, and even numbers in particular with the completion of a transition. First, as I observed from various offering rites performed during the contracting of a marriage, the portion of betel and areca for the clan ancestor (*marapu*) and that for the deceased forbears (*mameti*) were invariably specified on this occasion as including fourteen and sixteen pieces of dried areca nut respectively. This practice was explained to me as follows. The totals in this case form respectively seven and eight pairs or 'rows' (*batangu*) of nuts.⁸³ Seven should be offered to the ancestor because his portion should not 'fulfil' or be 'complete', since only in this way can the ancestor request (*karai*, also 'to show need') from God the eighth pair, which stands for 'the means to prosperity and fecundity' (*paworu pabàba wàngu*, also interpretable as 'progeny'), so that there will be completeness. If the offering included eight pairs of nut, the request could not be fulfilled. The portion for the dead, on the other hand, was said to contain eight pairs of nuts because 'the dead are complete' and therefore 'do not request (or require) anything'. In other words, then, in this context death is conceived as a completed transition. The second case in which these associations are revealed concerns a description I was given of an offering made when plants are taken to be used as fertility drugs. Though this should include seven pieces (rather than pairs) of areca nut, it was similarly explained that the seventh piece, since it 'lacks a partner', 'requests (or shows need of) the means to prosperity'. In a similar

rite concerning contraceptive medicines, by contrast, eight pieces of nut should be used.

It is clear, therefore, that the auspiciousness of even and uneven numbers is contextually relative, though since completeness usually signifies a desirable state of affairs, it is the former which are most often regarded as of good omen. The first example of the link between uneven numbers and life also reveals an instance in which such numbers are associated with the *marapu* ancestors; and because the *marapu* are beings transitional between mankind and the Divinity, this arguably involves then a connexion between uneven numbers and something analogous to sections between points of transition. However, while an association between the *marapu* and uneven numbers is suggested in at least one other context,⁸⁴ more often than not the contrary is indicated. Thus most offerings made to the ancestors, and indeed other forms of beneficent spirit, include an even number of components; and this is consistent with the fact that these entities are generally identified with points of transition, or boundaries, rather than with what lies between these. In the two examples outlined above, therefore, it would appear that uneven numbers are specifically linked with the condition of incompleteness itself, which the ancestors have the power to repair, rather than with the *marapu* as a category.

CHAPTER X

CLASS STRATIFICATION

Although, in a fundamental sense, everyone in Rindi participates equally and in the same way in the passage from birth to death and beyond, as I have indicated in several places above a person's position in society is significantly affected by his membership of a particular clan and social class. These aspects of Rindi social order, therefore, will form the subject of this and the following two chapters. A useful place to begin is the division into ranked classes. Since this division intersects the segmentary order of patrilineal clans — a single clan frequently including members of different ranks — and because class is one factor that determines whom a person may marry, the subject of this chapter is closely bound up with both the topic of descent group organization and that of marital alliance. Moreover, as class is the most important factor governing the distribution of temporal power in Rindi, the present discussion provides the essential background to the subject of the division of worldly and spiritual authority, which is treated in Chapter XI.

The distinction of class so permeates Rindi life that I have had to mention it frequently in previous chapters; and since this sort of division is a fairly widespread feature of Indonesian societies, it is important to consider the form it takes in eastern Sumba. I use the word 'class' — or, alternatively, 'rank' — to refer to a system of hereditary, ascriptive, hierarchical, and preferentially endogamous groupings that is recognized throughout the eastern part of the island.¹ The three principal divisions are *maramba*, 'nobility'; *tau kabihu*, 'clan people', i.e., commoners; and *ata*, which, for want of a more suitable term with which to describe this class as a whole, I shall call 'slaves'. The classes are each further divided into a higher (*bokulu*, 'big, major') and a lower (*kudu*, 'small, minor') stratum — the latter of which, among the nobles and commoners, derives from class inter-marriage — thus resulting in a hierarchy of six ranks.

There is no standard or generic term for the social classes in Rindi. Indeed, to which class a person belongs is a question the Rindi themselves never ask; and class difference is a subject they rarely speak of openly. While the division of classes is manifestly tripartite, logically it derives from two different sorts of distinctions: one between slaves and free persons and, within the latter category, another between commoners and nobles. It is useful, therefore, to consider the slave class first.

1. *Slaves*

Although the existence of a class of slaves is common in Indonesia (see Ruibing 1937), it is not reported in every region. Thus the Tetum of eastern Timor, for example, have only an 'aristocracy' and a commoner class (Hicks 1976:22), while on Roti the former class of slaves is no longer recognized (Fox 1968:128). Since various authors have claimed that a slave class is not found in certain parts of western Sumba as well, it seems, then, that in this respect there are marked differences to be discerned between closely related neighbouring societies. What is more, not in every society where slaves are reported do they form a truly hereditary group (see Fischer 1952:160).

Although the possession and alienation of slaves by the eastern Sumbanese nobility is reported from the eighteenth century (see Wielenga 1909b:302), how long a true slave class has existed in eastern Sumba cannot be fully answered on the basis of present evidence. Referring to the fact that in most western Sumbanese dialects the word *ata* has the meaning of 'human, person', an educated informant from Umalulu once suggested that it was borrowed with the introduction of a great many persons as slaves from the western part of the island, which is reported from the nineteenth century (see Kruyt 1921:532). Words cognate with *ata*, however, appear throughout the Austronesian languages, either with the sense of 'human' or with that of 'slave'; so it is not necessary to assume borrowing in this case. At present, *ata* in eastern Sumba can refer only to slaves, while the word for 'human' is *tau*.² But since *tau* is applied to members of all classes, there is no exclusive division of 'humans' and 'slaves'.

The Rindi distinguish two strata of slaves: the *ata bokulu*, 'major slaves', or *ata ndai*, 'slaves of old'; and the *ata kudu*, 'minor slaves', also called *ata pakei*, 'bought, acquired slaves'. The first group, which in ritual speech is designated as *tau memangu, njara ndai*, 'natural,

original people, horses of old', consists mainly of hereditary slaves, while the second comprises persons acquired by purchase or capture before the abolition of the slave trade and the suppression of internal wars by the Dutch. Traditionally, the *ata bokulu* received far better treatment than the lower ranking slaves, and unlike the latter they could not be bought and sold. Since the abolition of the slave trade, however, the condition of the *ata kudu* has improved; so the distinction between the two sorts of slaves, though it continues to be recognized for some customary purposes, is no longer so clear. The formal abolition of slavery has also resulted, in theory at least, in a greater degree of independence for both sorts of *ata*; but while, formally, there is now nothing to prevent slaves from detaching themselves from their traditional masters, few have chosen to do so. With the possible exception of the *ata kudu*, therefore, legislation by the Dutch and the present national government has yet to have more than a marginal effect on this aspect of the class system (cf. Fischer 1952:162).

Persons of slave descent form a large part of the population of Rindi, and the vast majority belong to the nobles.³ Only the nobility, moreover, have *ata bokulu* or hereditary slaves of long standing; thus all slaves belonging to commoners are considered *ata kudu* (or, it might alternatively be said, the distinction has not arisen in this case). While both sort of slaves are attached to one of the free clans or, among the nobility, specifically to one of the named lineages of that clan, and are ordinarily identified as 'members' (*tau*, i.e., 'people') of these groups, the Rindi do not regard them as full members or as legitimate descendants of the clan ancestor. Thus, although slaves too participate in the cult of this ancestor, strictly speaking they have no clan or *marapu* of their own. This, then, is what distinguishes slaves from freemen, and accounts for the designation of the commoner class as 'clan people' (*tau kabihu*). Similarly, while slaves are allowed to hold property and to cultivate land on their own account, privileges formerly accorded only to the *ata bokulu*, in the traditional view the rights to the land they work are held by their masters, and any wealth they may acquire is always at their disposal. Hence the nobles in Rindi are sometimes spoken of as the 'owners' of houses (*mangu umangu*) occupied solely by their slaves. Masters of slaves also arrange their marriages, though recently some slaves have begun to assert a measure of independence in this regard (see Chapter XV).

From what I was told in Rindi about slaves belonging to commoners,

and from the fact that they are all considered *ata kudu*, it seems that such persons were acquired as slaves comparatively recently. It may be, therefore, that at one time only the nobles could own slaves, but because of the large number of persons who came to be incorporated into the *ata* class, as war captives and refugees, during the last century and perhaps earlier, it became no longer feasible for the nobility to uphold their prerogative in this regard. I was also told that in former times slaves acquired by commoners were sometimes adopted into the clan as full members (presumably with a concomitant adjustment of genealogies, since I never found any conclusive evidence of this), and so would come to be regarded as freemen. However, I never heard of such a practice among the nobility, and I doubt very much whether it would ever have occurred in this case.

The origin of the *ata bokulu*, in particular the hereditary slaves of the nobles, is obscure, and I found no clear reference to it in myth. The Rindi usually claim that the nobility have always possessed slaves;⁴ yet I also encountered the idea that formerly there were no slaves at all, only a noble and a commoner class each divided into a higher and a lower stratum, thus, significantly perhaps, defining a quadripartition of ranks. Though I heard nothing in Rindi to support it, Kapita's (1976a:48) statement that hereditary slaves derive in part from an aboriginal population is interesting since the phrase *tau memangu*, which refers to hereditary slaves, can also be glossed as 'autochthonous people'.⁵ Another idea I encountered was that hereditary slaves first arose from the illegitimate offspring of noblemen and slave women (presumably *ata kudu*). While this too is not conclusive, it nevertheless accords with the fact that such persons, who are quite numerous in Rindi, are indeed counted as *ata bokulu*, regardless of whether their mothers were hereditary or acquired slaves.⁶

Some persons now classified as *ata bokulu*, however, are not in fact hereditary slaves of long standing, but the descendants of freemen who within recent memory were taken by the nobility as a punishment for wrongdoing, or who for political or economic reasons sought their sanctuary. One group of slaves in Rindi are known to descend from a man of higher commoner rank captured in war, who subsequently served the nobles as an invaluable military leader.⁷ Cases of this sort, then, suggest another possible derivation of at least some *ata bokulu*. While the situation of such persons is little different from that of commoner clients of the nobility (see Section 3 below), in

contrast to the latter, at present they are no longer recognized by the nobles as constituting even nominally independent clans. Recently, though, a number of them have endeavoured to re-establish their former clan identities and are now recognized as commoners by some other members of this class.

I was never able to establish whether the other higher ranking slaves of the Rindi noble clan (i.e., those of long standing) are thought to have a single patrilineal derivation; but whatever the case they now comprise a large number of small lineal groups, any former agnatic connexion between which is no longer remembered. Accordingly, while slaves are formally subject to the same rules of marriage in respect of category as the rest of the population (see Chapter XV), they are not bound by the rule of clan exogamy. Indeed, in some cases it is preferred that they marry other slaves belonging to their masters' clan and lineage. This situation, then, further underlines their lack of a true clan identity.

The Rindi euphemistically call slaves 'children in the house' (*anakeda la kuru uma*) and refer to them as their 'children' (*anakeda*, see Chapter VIII). *Anakeda* is also a usual way of summoning younger slaves, including young adults. The usage is thus consistent not only with the subordination and dependence of slaves, but also with the fact that, like children, they are not regarded as full members of the groups among which they reside. Another term for addressing or referring to the slaves of one's clan is *eri*, 'younger sibling, person', though as a vocative usage I found it employed only for persons who were indeed younger than the speaker.⁸ Considerably older persons of slave rank are addressed with the parent terms (*ama* and *ina*), and all slaves can be addressed by their proper names. The use of *eri*, and the reciprocal term *aya*, 'elder sibling, person', to distinguish rank is also found in the phrases *kabihu mamaeri*, *kabihu mamaaya*, 'junior most clans, senior most clans', which together denote the lower and higher strata of commoners and hence that class as a whole.⁹ In addition to expressing the distinction of age, and in other contexts that of junior and senior lines of a single descent group, therefore, *eri* has the more general sense of 'subordinate'. Another euphemism for slaves is *tau la lihi*, 'people by the side', which has connotations of assistance and support. As I shall later show, with regard to both this usage and the designation 'children in the house', slaves are spoken of in the same way as are wife-takers (see Chapter XIII).

At this point we should consider further the traditional differences

of social position and privilege between the *ata bokulu* and the *ata kudu*, the higher and lower ranking slaves. The Rindi distinguish two sorts of *ata bokulu*. One, which I shall call 'life slaves', is the *ata rànja* or *ata rànja maràmba*, a phrase difficult to translate exactly but which roughly means 'slaves whose lives are conterminous with those of the nobles'. At birth, a noble is assigned two life slaves, ideally full siblings, the elder of whom serves as his *ngara* or *ngara hunga*, 'visible name'.¹⁰ This concerns the custom whereby a noble person is called not by his or her own name but by a title, such as Umbuna i Ngabi, 'Lord of Ngabi', or Ràmbuna i Babangu, 'Lady of Babangu', which incorporates the name of an *ata rànja* of the same sex as the addressee. After his death, a nobleman is referred to with the most formal names of his two life slaves: the Lord of Ngabi, for example, would then be known as Lakibanju-Radajawa, the first name being the most formal of the three own names of the person ordinarily called Ngabi, the elder of the pair.¹¹ *Ata rànja* are also known as 'betel purse carried under the arm, cloth worn on the shoulder' (*kalumbutu pahili, hinggi paduku*), which alludes to the custom whereby a slave carries his master's betel container and knife on formal occasions. Female *ata rànja* serve as *ata ngàndi*, 'slaves brought along', the attendants of a noble bride who eventually marry *ata rànja* men of the wife-taking clan, and in the case of a woman's own *ngara hunga*, by preference the *ngara hunga* of her husband. Since a man's life slaves are thus ideally the children of his father's *ngara hunga* and an *ata ngàndi* woman who accompanied his mother, a noble lineage and that of its *ata rànja*, as they share the same alliance connexions, are brought together in a close parallelism. Because of this relation, such slaves can be referred to with relationship terms, e.g., *mamu tau ata*, 'slave father's sister', which denotes the life slave of one's *mamu* (FZ, etc.).

In order to distinguish them from life slaves, I was told, the remainder of higher ranking slaves, who by contrast are not employed as *ngara hunga* and do not normally marry outside the clan, may be called *ata memangu*, 'natural, original slaves'.¹² Women in this category, therefore, do not act as *ata ngàndi*, while slave women who do, conversely, may not marry within the clan; and if their mistresses do not marry, then they too must remain spinsters. In accordance with the rule that such person may not afterwards be alienated from their master's house, slaves who act as *papanggangu* (see Chapter IX) are drawn from the *ata memangu*; while, on the other hand, a noble-

man's *ngara hunga* slave should not serve him as a *papanggangu* after his decease. The various distinctions between the two sorts of slaves thus call to mind the binary contrasts of outside and inside, exogamy and endogamy, marriage (or life) and death, and perhaps, in a sense, that of alliance and descent.¹³ However, formally speaking, there is no difference in status between them such that one group could be described as higher than the other.

Some *ata bokulu*, often youngsters whose parents live in other villages, reside with the nobility, whom they then serve as domestic help and attendants. In fact, sometimes the principal house of a noble lineage is continuously occupied entirely by slaves, while the nobility live more or less permanently elsewhere. Other higher ranking slaves maintain houses of their own, usually located close to fields and pastures belonging to the nobility, which they then tend. In this way a large part of the noble clan's property is entrusted to slaves. *Ata bokulu* men, who are often better versed in ceremonial matters than are their lords, further serve the nobility as priests and ritual speakers. Owing to their strength of numbers and loyalty to the nobles, in former times higher ranking slaves also constituted a formidable political force within the domain and, according to Roos (1872:6), were as much looked up to by the populace as were the nobles themselves. Indeed, as I myself observed, in Rindi some such slaves still tend to adopt a rather high-handed manner with others of their class and even with commoners. It should be noted, then, that slaves of the nobility owe no special deference to members of the commoner class and in general seem to regard them as equals.

In contrast to the *ata bokulu*, the descendants of slaves of lower rank (*ata kudu*) are not assigned special ritual duties, and are still denied many of the privileges accorded to higher ranking slaves. The prohibition on lower ranking slaves entering the clan's ancestral house is thus still in force in Rindi, and they may not participate in the renovation of ritually important buildings. Similarly, whereas *ata bokulu* may be buried in the chief village (*paraingu*),¹⁴ persons of *ata kudu* rank must always be interred elsewhere. Since the two groups can no longer be so easily distinguished, however, these differences now appear gradually to be fading; and although it is said that each should marry persons of their own rank, it is not clear how often this rule is still followed. In former times, on the other hand, most *ata kudu*, being entirely without rights or position, led an impoverished existence as a marginal labour force and by all accounts

(see, e.g., Wielenga 1909b:304) received poor treatment from their masters. Thus on several occasions the Rindi described them as persons without worth or value. As noted, it was slaves of this sort who were once put to death at noble funerals.¹⁵ Clearly, the traditionally low status of the *ata kudu* can be ascribed to their relatively recent derivation from outside the community and hence the obscurity surrounding their origins; and it is consistent with this that such persons are thought more likely than others to be witches.

Though now illegal, the clandestine selling of slaves is said occasionally still to occur in eastern Sumba. These exchanges, however, appear to differ significantly from those carried out in earlier times. While, formerly, captives taken in internal wars included mainly women and children, adults of both sexes were once sold as slaves (see Wielenga 1909b:300), either among the Sumbanese themselves or to foreign slavers. The purchase price could consist of livestock, trade goods, and, in times of scarcity, even foodstuffs; there being no fixed price or type of goods required by custom (Roos 1872:10). In contrast, the few recent cases of slave purchase of which I heard rumour in Rindi all involved young women — male slaves, I was assured, can no longer be bought and sold — and in each instance the goods exchanged were of the sort used as bridewealth. In these respects, then, the exchanges appeared hardly to differ from marriage. Yet, as I describe in Chapter XVII (Section 4), there are other features that, for the Rindi, clearly distinguish the two sorts of transactions; and it is evidently with regard to these that such an exchange of slaves is spoken of as a 'sale' (*danggangu*) and not as a marriage. At present, therefore, these transactions are conducted surreptitiously, and the principals are reluctant to discuss them.

2. *The Nobility*

The higher or major nobility (*maràmba bokulu*) are distinguished from the lower or minor nobility (*maràmba kudu*) as persons who derive solely from forbears of noble rank. They are thus described as *maràmba lundungu*, 'nobility straight through', and *maràmba wua kaba* (*wua* is 'fruit', while *kaba*, 'coconut shell, skull', denotes the hardest, firmest part of something).¹⁶ The *maràmba kudu*, also known as (*maràmba*) *ana mandamu*, 'impoverished children', and *maràmba kawiru waa*, 'nobility separated, hidden below', therefore comprise noble persons who count among their female ascendants women of

commoner rank. As throughout eastern Sumba, the nobility in Rindi are the political rulers of the domain. Leadership, however, is more particularly accorded to the most senior of the higher ranking (*maràmba bokulu*) lineages of the noble clan, and then to the eldest or senior man of that group; so in some contexts *maràmba* is used to refer specifically to a single lineage (in Rindi the group called Uma Penji) or to the individual noble leader. The individual ruler can also be distinguished as the 'staff' (*tokungu*), referring to the symbol of office presented by the Dutch Colonial authorities.¹⁷

Before describing further the position of the *maràmba*, it is useful to say something more about the relation between clan and class. While a clan spread over several domains might, as a whole, include persons of all classes, unlike certain other domains Rindi has only one clan, Ana Mburungu, which includes a nobility; and all free lineages of this clan, except one, are of noble rank. The exception is the lineage Uma Kambata, which established itself in the domain more recently than the other lineages of the clan and, though it recognizes the same *marapu* ancestor, shares no known genealogical connexion with them. But while its members are strictly speaking commoners, in many respects Uma Kambata is treated as a junior line of the noble section of Ana Mburungu; so its position in the hierarchy is somewhat ambiguous. Junior lines of other noble clans that have moved to Rindi from elsewhere, on the other hand, are no longer regarded as nobility but as commoners. This apparent decline in rank is not due to marriage with lower class women, since no matter whom they (legally) marry, noble lineages never formally descend to the commoner class. Rather, it appears to be more a question of political context; that is, such groups, despite their agnatic relation to nobility elsewhere, are counted as commoners because, in contrast to the lower nobility of Ana Mburungu, and Uma Kambata, they are no longer corporately connected with lineages of high noble rank (*maràmba bokulu*).

According to a myth which is widespread in eastern Sumba (see Kapita 1976a:42), the *maràmba* class derives from a miraculous woman who descended from the heavens, or, as it is also stated, from the sun and the moon, to a spot in Wai Jilu, in the south-eastern corner of the island, by means of a golden chain.¹⁸ For this reason, in parallel speech the nobles are designated as 'children of the sun and the moon, children of the sky and the shoreline' (*ana lodu ana wulangu, ana awangu paliti*);¹⁹ and their association with the heavenly

bodies is further expressed in the idea that an eclipse, or 'death' (*meti*), of the sun or moon, or the appearance of a comet foretells a noble person's decease. Although the details of the myth were subject to some dispute in Rindi, its main theme (which is all that need concern us here) is clear enough, namely that over the generations the female descendants of the heavenly woman were circulated in marriage among just those clans whose members can at present claim pure noble rank. Thus, while the derivation of rulers from the sky is a common enough idea in Indonesia (see van Wouden 1968; Fischer 1952:163), this tradition appears to be distinctly eastern Sumbanese insofar as it indicates the ultimate basis of noble rank to be not patrilineal descent but marriage. The mythical woman herself (or according to other accounts, one of her daughters) married the founding ancestor of the Wai Jilu noble clan Kaliti, while a daughter of his was given in marriage to Umbu Mbadi Wohangara, the son of the apical ancestor of the Rindi nobility, Umbu Lutungu.²⁰ The Rindi therefore speak of Wai Jilu as the 'trunk, source' (*pingi*, a designation which, as I shall later show, is also applied to wife-givers in general) of the noble class and, with specific regard to Kaliti's position as the original wife-giver of their own nobility, as the 'land of the associate and honoured guest, land of the mother's brother' (*tana kula ariyaa, tana tuya polangia*).

As was first noted (though somewhat vaguely) by Roos (1872:4), in eastern Sumba a similar distinction is accorded to the ruling lineage of Tabundungu, which, before its extinction, was also a wife-giver of Ana Mburungu and many other noble clans besides (including Palai Malamba in Umalulu, another wife-giver of the Rindi nobility). It is significant, therefore, that according to genealogies recorded by Nooteboom (1940:146, 159), the Tabundungu nobility derive from a sister of the woman who descended from the sky at Wai Jilu; while in Rindi I was told that the Tabundungu noble clan was the first to take wives from the Wai Jilu nobility. Recalling the association between 'heads' and 'sources' or 'origins' noted in Chapter III, that these two domains should be distinguished in this way is consistent with the fact that Wai Jilu and Tabundungu each lie in the vicinity of one of the two places called *katiku tana*, i.e., the head of the island and the Head of the Earth (see Chapter III). In the case of Wai Jilu, moreover, this territory is the limit of a superior 'upward' (*dita*) direction and is associated with the sunrise; thus it seems most appropriate that the ancestress of the nobility should descend to the

earth at this place, which might be described as that part of Sumba most closely linked with the sky. The association of the Head of the Earth, near to which Tabundungu lies, with wife-giving affines was mentioned previously; and it was noted that this place is located upstream (*dia*), thus also in a superior direction, from the coastal domains, where the majority of the highest ranking noble clans are found. In these respects, then, ideas concerning the class hierarchy appear to be significantly in accord with spatial and cosmological categories. Also consistent with this is the fact that the eastern Sumbanese speak of the western Sumbanese, the 'people below' (*tau wawa*), i.e., at the 'tail of the island' (*kiku tana*), as being generally of lower standing than themselves.

In ritual speech, the nobility are further referred to as 'children of the crocodile and whale, children of the large jar and great basin' (*ana wuya tadanu, ana rumbingu kandapu*) and 'sea turtle, red crocodile' (*kara wulangu, wuya rara; kara wulangu* is 'moon shell');²¹ while crocodiles and turtles are also prominent among the figures carved on Rindi noble tombs. It is not clear, however, whether these usages are meant to express a direct link between the nobility and the sea, for they were said to signify no more than that, like crocodiles and whales in relation to other sea creatures, the nobles are manifestly superior to other men. And while a connexion with the sea is also suggested by the claim of certain eastern Sumbanese noble clans that their ancestors took wives from beings that inhabit the sea, there are other clans, of commoner rank, whose ancestors are reputed to have done so as well. A similar explanation was given for the appearance of the names of large trees of the genus *Ficus* in other expressions that denote the *maràmba*.²² Thus it was remarked that just as these great and prominent plants encompass and shelter a wide area, so the influence and protection of the nobility extends throughout the domain. Since the Rindi regard such trees as the houses of the 'lords (or nobility) of the earth' (*maràmba tana*) who preside over a host of lesser spirits, however, in this case the analogy with human society appears to be somewhat more pronounced. Furthermore, with regard to what I said in Chapter VI concerning both the uninhabited land over which these spirits have dominion and the sea where crocodiles and whales are paramount, these idioms might be seen to express a contextual association of the nobles with the outside. This concerns the opposition, which I shall discuss in the following chapter, between political rulers and religious authorities, who are associated with

the outer and inner sections of the chief village respectively.

As regards temporal power, on the other hand, the *maràmba* (perhaps more so in Rindi than elsewhere) are central to the traditional life of the domain, the physical embodiment of which is the chief village, where the oldest houses of the nobility are located. They are thus designated as 'mother and father in the chief village' (*ina la paraingu, ama la paraingu*) and the 'sinew of the land (domain), bone of the chief village' (*kalotu tana, rii paraingu*). Another pair of phrases expressing the hegemony of the nobility is 'rope (secured at) a hole in a stone, leather binding' (*liku uru watu, pendalu manulangu*),²³ which, like the previous expressions, suggests the idea of order and strength. The nobles are also called 'mother duck, father chicken' (*ina rendi, ama manu*), since like these fowls, which bear many offspring, they have dominion over a great many subordinates.

Because the traditional power of the *maràmba* is no longer recognized by the government, what follows is in part a reconstruction. The impression of noble leadership conveyed by earlier writers (see, e.g., Roos 1872:5-8) is one of a rather diffuse and arbitrary form of rule; and by all accounts the eastern Sumbanese nobility during the nineteenth century governed in a harsh and autocratic manner. While to some extent the nobility acted as guardians of public order, and in Rindi are still sometimes called upon to offer advice in litigation between free clansmen, following Roos (1872:5) such intervention was unsystematic and motivated largely by self-interest. Before colonization, it seems there were no regular courts at which the nobles would adjudicate disputes, such as Fox (1971b:224) mentions for Roti, although as I was told in Rindi they did have persons who were suspected of being witches put to death and took thieves and other wrongdoers as slaves. As I shall elaborate below, the nobility also exercised some control over marriages contracted by free clansmen within their domains.

Perhaps the most important function of the nobility in Rindi, however, was the leadership they provided in all matters relating to war and the defence of the domain. In this and in other respects, their power largely derived from their great wealth and, especially, from their possession of large number of slaves, who could be deployed as both a military and a civil force. Slaves, of course, also provide labour and, in the case of women, serve as wives for commoner clients who, as I shall presently describe, are thus brought into a relation of direct dependence on the nobility. Most of the sumptuary prero-

gatives and other usages exclusive to the *maràmba*, many of which I have already noted, similarly presuppose superior wealth and the possession of slaves, in particular hereditary slaves (*ata bokulu*). It is evident, therefore, that the highest class depends for its power and privileges on the lowest; so without slaves noble rank would amount to very little.²⁴ Yet it is also clear that wealth in itself is not sufficient to secure these privileges. Thus wealthy commoners in Rindi explained that formerly they had deliberately to construct smaller houses and less elaborate graves than those of the nobles, and to make smaller expenditures at marriages and funerals, in order to avoid their displeasure. The rule to be followed, I was told, was 'do not (appear to) be equal to the nobility' (*àmbu pahamanya na maràmba*), a maxim which to a large extent is still observed today.

Despite the fact that their rank no longer entitles them to exercise formal political authority, therefore, the nobility continue to exercise a great deal of influence in Rindi society, and it would be difficult to overstate the extreme deference with which they are treated by the lower classes. One expression of their superior status is the special methods of addressing and referring to the nobles. As noted, their proper names may not be used,²⁵ and instead they must be addressed with a *ngara hunga* title formed from the name of a slave, or, in the case of the higher nobility, with a nickname.²⁶ Nicknames usually refer to a physical or behavioural attribute, but since the designation is commonly inherited with the proper name with which it is connected, rather than assigned anew, it then actually refers to a characteristic of the person's namesake forbear. The vocative terms *umbu* and *ràmbu*, 'lord' and 'lady', while also employed in respectful address to commoners, are mandatory forms of address for noble persons. Women of the higher nobility, and by courteous extension women of lower rank married to noblemen, however, must be called *tamu ràmbu*, which, as *tamu* is 'name, namesake', might be glossed as 'lady's namesake'.²⁷ All these special forms of naming, therefore, entail that the person is indicated indirectly, by reference to another party. This is reminiscent of the fact that superior forms of spirit, or what may be called the Divinity, must similarly be approached indirectly by way of an intermediary, and indeed the designating of God as 'the one whose name cannot be uttered'. As I have shown, there are other usages which suggest that God and the nobility are conceived analogously. While this is hardly surprising, it is worth recalling here the association of both the nobility and divinity with wealth, particularly

precious metals, which is seen to reflect divine favour, and with the heavenly bodies, from where both the nobility and precious metals are thought ultimately to derive.²⁸ Also relevant in this regard is the Rindi view of the more elaborate ceremonial practices of the nobility, in fact their exclusive way of life generally, as, in a sense, ideals or models of conduct, of which those of the lower classes are but impoverished reflexions. Thus I often found that what the Rindi spoke of as a general norm or even a prescription could, for the reasons noted above, in fact be fulfilled only by the nobles. In this respect, as well as with regard to the power both hold over ordinary (mortal) men, Rindi attitudes towards the *maràmba* closely resemble those they hold towards the ancestors (both the *marapu* and more recent forbears). They thus describe the ancestors as the ones 'who show the way (and) indicate the pattern' (*paita pata, pailu ngera*) in customary affairs; and the present life is similarly represented as but a poor reflexion of that lived by previous generations. These parallels indicate, then, that the class hierarchy can be conceived analogously to the successive stages of being, in which respect it should further be recalled that persons of the lowest social class are called 'children'.

3. Commoners

The commoner class is best described as a negative category: it comprises persons who, unlike slaves, retain an independent clan identity — a recognized link with one of the founding ancestors — yet have no claim to nobility. The division of this class into a higher and a lower stratum, the *kabihu bokulu* and *kabihu kudu*, is usually defined with reference to marriage, the latter being persons whose female ascendants were slaves. Among commoners, however, purity of descent is less important than among the nobility, and whereas men of the lower nobility may not normally marry women of the higher nobility, marriage between *kabihu kudu* men and *kabihu bokulu* women is rather less disapproved of. Sometimes, moreover, the Rindi speak of the distinction as being simply a matter of economic differences or of lineal seniority, *kabihu bokulu* thus denoting wealthier commoners or the more senior lines of commoner clans. But since it is usually poverty that leads to marriage with slave women, clearly these criteria often coincide. (The relation between class, wealth, and seniority of descent is further discussed in the next section.)

In general, therefore, *kabihu kudu* are poorer commoners directly

subordinate to higher ranking members of their own clans or to the nobility. The latter case concerns what may be called clients, commoners who regularly take wives from among higher ranking slaves of the nobles. While such persons are therefore obliged to provide the nobility with goods of the sort used as marriage prestations whenever the latter require these, however, they do not formally pay bridewealth for their slave wives; hence they remain, so to speak, continually in a state of debt.²⁹ The subordination of client commoners is thus subsumed under a particular form of the alliance relation in which the *maràmba* are the superior wife-givers. A higher ranking commoner who marries a female slave of the nobility by paying bridewealth, on the other hand, does not enter into any such position of dependence; and the children of such men, while nominally *kabihu kudu*, in cases I was familiar with seemed otherwise to be little affected by their mothers' rank. The crucial factor in this regard, therefore, is the payment of bridewealth.

In most practical respects, the position of commoner clients is little different from that of higher ranking slaves; indeed, the Rindi sometimes refer to them as slaves. Thus, if clients marry *ata ngàndi* women from the noble clan's wife-givers, their daughters can in turn be employed as *ata ngàndi*, and their children of both sexes can be assigned to serve as the 'visible names' (*ngara hunga*) of their noble patrons. They may also be called upon to act as *papangganggu*; and the girl who serves as the substitute for a bride of high noble rank is usually the daughter of a commoner client. In addition, clients are obliged to contribute in the same way as are slaves to the corporate undertakings of the noble clan, and traditionally the rights to the land they worked were held by the nobles. In contrast to slaves, however, many such commoners in Rindi maintain ancestral houses of their own and in other ways (e.g., by the observance of special dietary restrictions) continue to express their individual clan identities. But in other cases, especially when the group consists of just a few persons, the recognition by the nobles of a client's clan name seems to have little significance other than as a convenient means of distinguishing such persons from their slave affines. A friend of mine in this position could thus simultaneously identify himself as a member of his father's clan (Halopi) and of Ana Mburungu Uma Kopi, the noble lineage of which his mother was a slave.

The *kabihu bokulu*, by contrast, are not directly subordinate to the nobles in respect of alliance connexions and act mostly independently

of them in other corporate matters. Nevertheless, in a wider context they are still subjects of the noble rulers. One manifestation of this is the part formerly played by the eastern Sumbanese nobility in marriages involving higher ranking commoners within their domains. Thus Roos (1872:49) states that a 'family of any significance' should inform the ruler before a marriage takes place and that the children of a union disapproved by the nobility because of disagreement in rank between the spouses could be taken as slaves. He also refers to a marriage contracted between a *kabihu bokulu* man from Kambera and a woman of like rank from Tai Manu that was supervised by the ruler of the latter district (ibid.:50-52); and both Roos (ibid.: 49-50) and Kruyt (1922:500) mention the making of gifts to rulers when a marriage is contracted.³⁰ Although the extent to which the custom is still observed in Rindi is unclear, I was similarly told that commoners of higher rank should inform the nobility beforehand of a proposed marriage between their members. A wife-giver should then present the nobles with (minimally) a textile, and a wife-taker should give a horse and pendant, both gifts later being reciprocated with valuables of the opposite sort as part of the exchange of *eri wili*, or 'junior bridewealth' (see Chapter XII, Section 3, and Chapter XVII).

In the past, the *kabihu bokulu* served the nobles as valuable military allies; and at present as well, they act as advisors in customary matters and provide the nobility with the most accomplished ritual speakers. Though commoners traditionally owe no regular or fixed tribute in goods or services to the noble clan, all members of free clans can still be called upon to provide labour and materials for the renovation of noble houses and the harvesting of their wet rice fields. Commoners of higher rank also take part in the exchange of prestations at noble marriages and funerals, receiving in return goods of the opposite kind.³¹ Similarly, whenever the noble clan in Rindi must receive large numbers of affines as guests, each of the commoner clans regularly aligns itself with one of the named lineages of this clan, and when needs be some guests might be accommodated in the commoners' own houses. Formerly, high ranking commoners were also more or less obliged to provide the nobles with sacrificial animals at major ceremonies; and some still freely do so if requested. On such occasions, then, the free clans of the domain can be seen to form with the *maràmba* a corporate unity (see further Chapter XII).

Since in many respects the nobility, together with their slaves and

clients, form a self-sufficient nucleus of the domain, however, the position of high ranking commoners in Rindi is on the whole rather peripheral. It is consistent with this that the Rindi nobility have a rather ambiguous attitude towards independent commoners, either ignoring their free clan status or acknowledging it only grudgingly. When describing to me variations in ceremonial practices between the classes, for example, the nobles and their slaves would thus commonly speak of 'customs of the nobility' (*huri maràmba*) and 'customs of slaves' (*huri tau ata*) as though these two categories were exhaustive. The commoners themselves, while otherwise steadfastly defending their independent status, moreover, tend to reinforce this dualistic representation of class standing by occasionally referring to themselves as *ata* in the presence of noble persons in order to effect humility. The discrimination mentioned in Chapter III between *la paraingu*, '(people) of the chief village', i.e., the nobility, and *tau la woka*, 'people of the fields', which refers to the rest of the population, similarly suggests a binary view of class. This representation, however, is noticeably inconsistent with economic differences between the classes. Thus wealthy commoners, who often possess slaves, lead a life not dissimilar to that of the nobility, and by virtue of their wealth are frequently able to exercise considerable influence in society. It is possible, therefore, to divide (though not quite exhaustively) the various ranks into two economic classes, one comprising the *maràmba* and at least some of the *kabihu bokulu*, and another consisting of slaves and commoner clients. But the fact that the Rindi themselves have no classification that closely corresponds to this division shows again that wealth or economic power, although of great importance in their lives, is related only indirectly to the formal distinction of class, which as I shall presently show is defined instead by the combined factors of descent and marriage (or alliance). The most important difference for the Rindi is thus not that between rich and poor, but that between nobility and non-nobility. In the view of the nobles and their slaves, at any rate, the distinction between slaves and non-slaves, too, is apparently less significant than this.³²

4. Class, Descent and Alliance

We are now in a position to consider more fully how class articulates with other aspects of the social order. Although class endogamy is preferred, noblemen and commoners may also take wives from the

class immediately below their own — thus *maràmba* men can legally marry commoner but not slave women — and, as noted, it is from marriages between the classes that the lower strata of nobles and commoners derive. Of course, further inter-marriage between the six named strata makes possible finer distinctions than those formally recognized by the system. Thus while children of *maràmba bokulu* men and *maràmba kudu* women, for example, are (formally) classified as *maràmba bokulu*, the Rindi yet regard their rank as somewhat ambiguous, and, informally, they consider them to be of a lower standing than persons both of whose parents are *maràmba bokulu*. In fact, some informants went so far as to say that they should actually be classified as members of neither stratum and should be called simply *maràmba*.

When men marry outside their class, therefore, they normally marry down; and though it sometimes happens that a man will be able to contract a legal marriage with a woman of the class immediately above his own, this is usually difficult and is generally disapproved of. Marriage between slave men and noble women, on the other hand, is strictly forbidden. In marriages between the classes, then, women are nearly always transferred in a single direction, namely upwards, in a way that might be compared with the prescribed unilaterality enjoined by the system of marital alliance in general.

Because wife-givers, as a category, are considered superior to wife-takers (see Chapter XIII), however, in cases of class inter-marriage alliance status normally runs counter to class standing; for it is then the party of higher rank that is the inferior from the point of view of the alliance. But since this situation presents no problems for the Rindi, who never confuse the two contexts of subordination, it indicates no more than the need, when analysing societies that practise asymmetric alliance, to differentiate between the relative distinction of alliance status and the absolute distinction of class. The two types of superiority relate moreover to entirely different things: as I shall later show, the superordinate position of a wife-giver is conceived in terms of what can be called spiritual or mystical power, while higher class standing concerns only worldly or temporal authority.³³

As the foregoing remarks clearly show, a lineage's class standing depends on maintaining marriage alliances with wife-givers of equal rank. The preference for marriage with the MBD and other closely related women from the mother's group (see further Chapter XV) is significant in this respect, since with regard to class such a union

represents, so to speak, the safest form of marriage. The availability of such women is thus a crucial factor affecting distinctions of rank within agnatic groups. To cite the extreme case, when there is only one woman from the mother's group available, she is normally married to the eldest of a set of brothers. The younger brothers must then turn for wives to other lineages of the mother's clan or to other clans, who, because normally it is possible to marry only women of the same or lower rank, are likely to be lower in standing. Because of this practice, then, higher rank and seniority of descent generally, though not invariably, coincide in Rindi.

These considerations apply especially to the nobility, among whom only a minority, for the reasons just mentioned, have managed unequivocally to retain the rank of *maràmba bokulu*. Throughout eastern Sumba such persons are now few in number, and in several instances lineages which could recently claim this rank have since died out. Yet the highest nobility appear always to have been a small group, confined to certain domains — notably those in the coastal regions — which has preserved its elite status through endogamous marriage articulated and consolidated by the preference for the MBD.³⁴

As the priority accorded to the eldest brother in marriage agrees with the rule of primogeniture, this is an appropriate place to discuss inheritance and succession. After his death, a man's goods pass to his eldest son, who then succeeds to the father's position of authority within the family and the clan. Though younger sons have a claim to this wealth — for example, when marriage payments must be met on behalf of themselves or their children — the eldest brother retains the greatest say regarding its disposal, and if the inheritance is later divided he receives a somewhat larger share than the other brothers.³⁵ As the bulk of such wealth comprises goods of the sort used as marriage payments, the eldest brother thus has a greater degree of access to bridewealth; and since the amount of a bridewealth varies with the bride's rank, the children of the eldest brother will therefore be in a better position to preserve their class standing than will those of younger brothers. Also, over time, they will be able to obtain larger amounts of bridewealth for their women. Hence, in the long run, lineal seniority tends to be associated with greater wealth as well as with higher rank.

As high rank and lineal seniority are conjoined only by virtue of marriage practice, however, the two do not always coincide. Thus, because in plural marriages the first wife may not be the highest

ranking or the most preferred spouse, a younger line may attain a higher class standing than an older one. In the next chapter I shall show that this is what has occurred within the noble clan in Rindi. It can also happen that through gradual impoverishment, the senior line of a *maràmba* clan is unable effectively to maintain leadership or otherwise fails to contract marriages with women of the appropriate rank, in which case a more junior line may take its place. The same can occur with a group of brothers when the eldest lacks leadership qualities or for some other reason is disfavoured by his father. The rule of primogeniture is thus not immutable.

The importance of marriage for the articulation of class differences is further shown by the fact that, in native theory at least, by consistently marrying higher class women (which, as noted, is just possible in Rindi) a line is able to rise to the rank of its wife-giver. Thus, with reference to several cases where *kabihu bokulu* men had married *maràmba kudu* women from other domains (notably Mahu and Mangili), I was told that were such an alliance to be continued in a single line for four generations, the great-grandchildren (SSC) of the original couple would acquire the rank of *maràmba kudu*.³⁶ I suspect, however, that unions of this sort are feasible only when they involve clans from different political domains; accordingly, no commoner clans in Rindi have taken *maràmba kudu* women from the noble clan there, and I am sure it would not be permitted. Though the Rindi nobility denied it, elderly informants claimed that it was possible for a *maràmba kudu* man to take a *maràmba bokulu* wife and thereby eventually to raise the rank of his lineage in the same way.³⁷

Marriage between slave men and commoner women is also possible, and though such unions have probably become more frequent since the formal abolition of slave status by the Dutch, they seem to have taken place before this time as well. Marriages of this sort, however, clearly involve factors different from those that concern unions between higher ranking women and lower ranking men of other classes. Thus, particularly where slaves of the nobles are concerned, there is no question of the man's children and descendants rising in rank. Since traditionally, at any rate, bridewealth for the woman would be paid by the slave's masters, she and her children would be incorporated into the clan as slaves. But there are also cases such as that of the clan Maritu, the descendants of slaves from Mahu who, following a dispute with their lords, fled to Rindi and by consistently marrying commoner women have subsequently established themselves

as an independent commoner clan. It can happen as well that the slaves of a clan whose noble members have died out will gradually come to be recognized as commoners in the same way. In such cases, therefore, the achievement of commoner rank through marriage first requires that the slave group somehow detach itself from its masters and form itself into a viable, independent corporation.

It is evident from all that has been said so far that a woman's rank has a crucial bearing on that of her children. A further illustration of this is the case of a man born from an adulterous relation between a slave and the *maràmba bokulu* wife of a Rindi nobleman, who because of his maternity is considered a *maràmba kudu* and a member of his mother's legal husband's lineage. I was also told, however, that if the biological paternity of such a child were known in advance it would be aborted; and I suspect that the offspring of an unmarried noblewoman and a slave would not be classified as nobility. Apparently, then, the decisive factor in this particular case was that the mother was legally married, in other words, that the child had a legal pater of noble rank and was born in the context of an alliance. Nevertheless, because of the rank of his natural father, he was not allowed to take a wife from the lineage of his mother's brother.

Despite the qualifications that apply to particular cases, therefore, it seems possible for members of all classes to raise the rank of their lineages through mixed unions.³⁸ What is more, since marriage with higher class women is generally more expensive, because of the wife's rank and because initially it involves starting a new alliance (see Chapter XVIII), the practice, like that whereby impoverished groups decline in rank, suggests a means by which increased wealth is brought into line with class: the lower ranking wife-taker then rises in standing while the higher ranking wife-giver benefits materially. But this process — and indeed, the possibility of marriage with women of higher rank itself — is to some degree countered by the prescriptive nature of the marriage system, which encourages the perpetuation of established alliances and hence supports the preference for class endogamy. In other words, the system of class and that of alliance have in common that both restrict the range of one's potential affines. Class membership and established alliance ties may therefore be regarded as similar properties of agnatic groups: both are in a sense inherited and both must continually be ratified through actual marriages. Since differential marriage ties among members of larger agnatic groupings (e.g., clans) create internal distinctions of rank, moreover, patrilineal

descent and matrilineal alliance can be viewed as complementary principles of social organization that relate to clan and class respectively. And as is especially suggested by the mythical origin of the *maràmba* class, they might also be contrasted as masculine and feminine principles of segmentation.

There is in this respect, however, one feature of the system that requires further mention, namely the fact that while a lineage can eventually rise in class standing by marrying women of a higher class, the descendants of men who marry lower class wives, while they are therefore assigned to the lower stratum of their father's class, never formally descend to the class of their mother. Except when men marry up, then, membership of the three major classes is evidently determined by patrilineal descent. Nootboom (1940:125), on the other hand, interprets the eastern Sumbanese class system as one of matrilineal descent. But that he is mistaken in this becomes even more clear when it is considered that successive generations in a matriline will be of the same rank only when their respective fathers (who will necessarily belong to different patrilineal clans) are also of the same rank. In effect, therefore, Nootboom has confused descent with an aspect of matrilineal alliance; so rather than speak, as does Nootboom, of the importance attached to the rank of the mother, is it better to speak of that placed on the class standing of the wife-giver.

CHAPTER XI

THE DIVISION OF AUTHORITY

The component relations of the class system just described clearly entail inequalities of worldly power. As I mentioned in Chapter VIII, however, superiority in the religious sphere is based on different considerations; thus class stratification must further be viewed in the context of a division of types of authority, which for analytical purposes may be called temporal and spiritual or secular and religious.¹ Van Wouden (1968) has shown this sort of division to be widespread in eastern Indonesia, while more recent studies (see, e.g. Cunningham 1965; Schulte Nordholt 1971; Fox 1968) have provided detailed descriptions of the various forms it takes in particular societies. But analogues of the system appear throughout the world (see Hocart 1970; Needham 1960a), perhaps most notably in the Hindu theory of sovereignty (see Coomaraswamy 1942; Dumézil 1948); so it is hoped that the present topic will contribute to a wider comparative framework than that derived from eastern Indonesia alone.

While a separation of two sorts of authority can be discerned in various contexts of eastern Sumbanese social and conceptual order,² its clearest expression is found in a dual partition of leadership functions between lineal descent groups within the domain, the most inclusive level of political and territorial integration. Following Needham (1968:XII), then, this may be called a form of 'complementary governance' or 'dual sovereignty'. Since the pattern is rather less pronounced in Rindi than elsewhere, however, it is useful first to outline a more elaborate form that appears in the neighbouring domain of Umalulu. Indeed, certain particulars of the Rindi organization can be fully appreciated only by considering beforehand the constitution of the latter domain. Though in so doing I will refer to categories and principles of order previously discussed with specific regard to Rindi, this procedure is justified by the fact that the two domains share in

all essential respects the same culture and social institutions and speak the same language.

1. *Ratu and Maràmba*

Temporal power and spiritual leadership in Umalulu are divided between the noble rulers (*maràmba*) and the *ratu*, the highest religious authorities.³ Rindi differs from this domain in that the latter office is formally absent there. Contrary to the impression conveyed by some earlier writings on Sumba, in Umalulu the title of *ratu* applies not exclusively to a particular individual leader, but collectively to a number of clans; and all members of these clans can be called *ratu*. Another potential source of confusion is the translation of *ratu* as 'priest' (see Wielenga 1909a:307), since this word is more appropriately used to designate elders (*ama bokulu*), of any clan, who engage in priestly duties. As noted, unlike *ratu*, this is not an hereditary office but a vocation requiring no more than age and experience. Some writers (Lambooy 1927:233; Kapita 1976a:40), moreover, have spoken of the Sumbanese *ratu* as the fourth, indeed the highest, social class, which notion seems mainly to refer to the fact that they occupy a special place within the domain and, in a sense, are considered superior to the *maràmba*. But in secular terms at least, I found that the *ratu* clans of Umalulu were spoken of as commoners; while other evidence suggests that they were originally a type of nobility. Actually I think the most accurate interpretation of the matter is that the *ratu* stand apart from the order of classes altogether.

In Umalulu there are two *maràmba* clans (i.e., ruling clans that traditionally included members of the highest noble rank), Palai Malamba and Watu Pelitu; and four *ratu* clans, Watu Waya, Muru Uma, Ongga, and Marapeti. The senior members of the two groups are respectively Palai Malamba and Watu Waya, and it is between these two clans that the distinction of *maràmba* and *ratu* primarily applies. The relation of the two sorts of leaders is defined in the myth of Umbu Endalu, the principal ancestral figure in Umalulu, from whose many wives (fourteen in all, by one account) derive many of the oldest clans in the domain. Umbu Endalu's first wife was the mother of Kaluu Rihi, the ancestor of the *ratu* Watu Waya, while the ancestor of the *maràmba* clan Palai Malamba, called Tunggu Watu, was the son of a later wife, or according to another account (Kapita 1976b:89), the younger son of the same wife (see Fig. 6).

The Umalulu people thus distinguish the principal *ratu* and *maràmba* as *aya* and *eri*, elder and younger brother. As van Wouden (1968:28, 50, 53-4, 62, 115) has shown, a division of spiritual and temporal authority between parties regarded as older and younger is very common in eastern Indonesia; and in this case it accords with the general identification of the oldest member of a class with (greater) spiritual power, which I have variously illustrated in previous chapters.⁴

The distinction of elder and younger as between the *ratu* and *maràmba* is also consistent with the order in which their apical ancestors arrived in the domain. According to myth, Umalulu was earlier occupied by Kàbalu, the ancestor of the clan Lamuru, after he had expelled an aboriginal population. He was removed in turn by Kaluu Rihi, the Watu Waya ancestor, who was the first of the present inhabitants to enter Umalulu. To accomplish this task, however, Kaluu Rihi had to summon his father, Umbu Endalu, from Haharu Malai (Cape Sasar) where the pair had earlier landed together on Sumba; and by means of a series of deceits, aimed at convincing Kàbalu that Kaluu Rihi had actually arrived in Umalulu before him, they managed to induce the earlier inhabitant to give up his claim to the land and leave the district.⁵ Kàbalu eventually settled in Patawangu, to the north of Umalulu.

Since Umbu Endalu's other son, the ancestor of the noble clan Palai Malamba, is said to have accompanied his father to Umalulu, and thus also to have assisted his elder brother in wresting the domain from Kàbalu, both the principal *maràmba* clan and the *ratu* are sometimes designated together as the *mangu tanangu*, 'owners of the land', an office I shall describe further below. Usually, though, it is the *ratu* alone who are spoken of as the *mangu tanangu* of Umalulu; hence in ritual speech the names of the four *ratu* clans are used to refer to the domain as a whole. As I shall later elaborate, this view accords with the fact that Kaluu Rihi was the very first of the present inhabitants to occupy the land; thus the *ratu* (in this case, particularly Watu Waya) are spoken of as the 'original people, inhabitants' (*tau memangu*) of the domain. The idea that both the *ratu* and Palai Malamba are *mangu tanangu*, on the other hand, is consistent with the fact that removing Kàbalu required the intervention of Umbu Endalu (and Tunggu Watu), in other words a combination of both spiritual and secular power.

Considerations of descent and temporal precedence similarly account

for the juniority of the second *maràmba* clan, Watu Pelitu, to Palai Malamba. Briefly, the ancestor of this clan, Lua Wuli, was the son of Ndilu Harahai, who was born of Meta Maninggalu, the ancestor of the clan Mangola in Wai Jilu, and Hendaru Mandàri, the MBD and rightful spouse of Umbu Endalu (see Fig. 6).⁶ There is not enough space to outline the circumstances of this woman's marriage to Meta Maninggalu. Insisting on his rightful claim to her, however, Umbu Endalu later abducted and married Hendaru Mandàri; so despite his biological paternity, the Watu Pelitu ancestor is considered a legitimate grandchild of the Umalulu ancestor. That this clan is inferior to Palai Malamba, therefore, can be ascribed both to the Watu Pelitu ancestor's being a member of a lower generation than that of the other noble clan and to the fact that his father was not a natural child of Umbu Endalu. Palai Malamba's superiority in this respect also accords with its position as principal wife-giver of Watu Pelitu.⁷ Since Watu Pelitu first established itself on Sumba at Pariripu in Kanatangu, moreover, the clan was a somewhat later arrival in the domain. It appears, then, to have been extraneous to the original division of powers between the *ratu* and the *maràmba* (Palai Malamba), a situation which fits well with the special circumstances surrounding the birth of the Watu Pelitu ancestor.

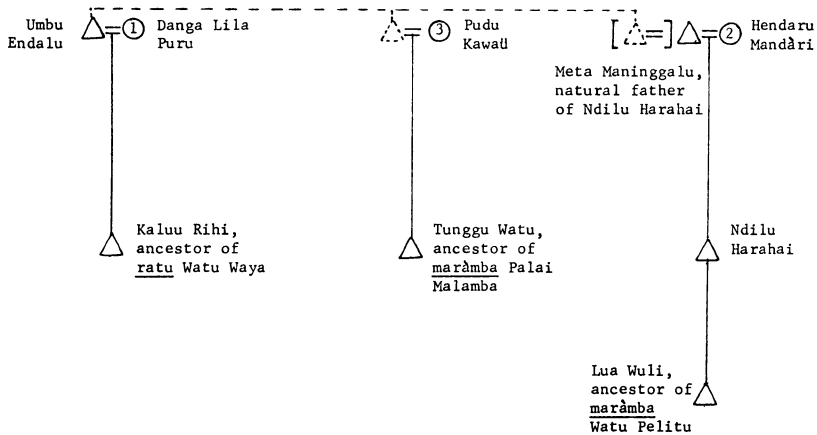

FIG. 6. Genealogical Relations among the Ancestors of the *Ratu* and *Maràmba* of Umalulu. (Wives of Umbu Endalu are numbered in accordance with relative marriage order)

As is consistent with the position of the eldest brother as the surrogate and successor of the father, the religious authority of the *ratu* in Umalulu derives of course from the fact that this party's ancestor is the one most closely connected with the principal ancestor, Umbu Endalu. In Chapter VI, I noted that elder and younger brother are associated with the inside and the outside respectively. In Umalulu, this opposition is reflected in the fact that the *ratu* occupy the superior central section of the chief village, and the *maràmba* the two outer or peripheral sections. The centre of the village also contains a small, roughly made, uninhabited building called the *uma nda pataungu*, *panongu nda pakelangu*, 'house without occupants, unsupported ladder'. Since it contains the relics consecrated to Umbu Endalu, it is regarded as the seat of this ancestor. Indeed, the house and its spiritual occupant are so closely identified that the name of the building can refer equally to both; because he is so highly revered, the ancestor's proper name (Umbu Endalu) is hardly ever spoken. The *uma nda pataungu* is thus described as the *uma lilingu*, 'forbidden house'. As the building is the responsibility of the *ratu* — who are spoken of as its guardians — the individual ancestral houses (*uma marapu*) of the four *ratu* clans are clustered around the uninhabited house in the centre of the village. While the chief village is now virtually abandoned,⁸ and the *uma nda pataungu* is no longer in evidence, formerly the Umalulu people would renovate the house each year⁹ just before the onset of the rains, as part of a major ceremony concerned with fertility and renewal. The ceremony was led by the *ratu*, and all the clans of Umalulu were required to take part.

The *uma nda pataungu* thus provides a particularly clear example of the association of a centre with spirit or divinity. The central part of the chief village of Umalulu also contains a vacant area surrounded by a low stone wall, now overgrown with dense bush. This is called the *paoka*, 'enclosed space', and is reputed to contain a number of very old graves. Originally, I was told, the *uma nda patuangu* was built inside the enclosure but was later moved outside. Like the inhabited house itself, therefore, the empty *paoka* calls to mind other instances of vacant or relatively unmarked centres, identified with divinity in its superordinate, otiose, and undifferentiated aspects and so conceived in opposition to more manifest and active forces located at the margins (see Chapter VI). Moreover, the pattern of the four *ratu* clans grouped around the superior, uninhabited house in the centre of the village is especially reminiscent of the spirits identified

with the four main house posts and the centre of the house foundation; and both arrangements call to mind the four-five pattern found elsewhere in Indonesia (see van Wouden 1968; van Ossenbruggen 1918), in which the fifth, central element generally unites symbolically the subordinate four.

In Umalulu, the unitary character of the centre of the chief village finds expression in the association of this place with the single ancestor from whom derive both the *ratu* and the *maràmba*. It thus represents the unitary source of a division of spiritual and temporal power, in which regard it is worth recalling that the words for centre, *padua* and *kàni*, connote division and apportionment (see Chapter II). Because of their special connexion with the ancestor, however, it is the *ratu* who are specifically concerned with the unitary aspect of this duality. The *ratu*'s position thus closely parallels that of the 'sacral lord' of the Atoni, whom Cunningham (1965:371) describes, in relation to the four 'secular lords' of the four great quarters of the domain (in this case Insana), as the 'unifier of the principedom', and who, like the *ratu*, occupies the centre of the domain, which the Atoni call the 'root' (ibid.:365). Furthermore, as among the Atoni (ibid.:373), the unity of the domain in Umalulu is principally expressed in major renewal ceremonies such as the renovation of the *uma nda pataungu*, in which context the *maràmba* are plainly subordinate to the *ratu*. The significance of the 'principal ruler' on Timor (generally a figure analogous to the 'sacral lord' of the Atoni), as a representative of a higher unity in which divided entities are conjoined, has also been noted by van Wouden (1968:102, 110-13, 165). In this respect, he remarks that '... the similarity between the ruler and a *deus otiosus* is truly striking' (ibid.:165). It is relevant, then, that in Umalulu both the *ratu* (in particular the two principal *ratu* clans, Watu Waya and Muru Uma) and Umbu Endalu, the paramount ancestor, are called 'the one(s) with folded arms, who sit cross-legged, the quiet and the still' (*na maangu luku, mahara jawangu, na makandii na makanawa*), and *mahanggula, mahanganji*. As I noted in Chapter V, these phrases are also used to refer to God. They further express the passive and inactive nature of the *ratu*'s leadership in contrast to that of the *maràmba*, a point I shall consider just below.

Due to the abandonment of the chief village in Umalulu and the consequent neglect of customary undertakings that once required the concerted involvement of the two sorts of leaders, it is now difficult to determine what precisely were their roles in specific situations.

From what I was told, however, it seems that in general the *ratu*, by virtue of their authority and expertise in customary and religious matters, informed decisions formally taken by the two leaders together, which were then expedited by the *maràmba*. While the noble rulers might initiate projects, the prior approval of the *ratu* for any undertaking was necessary in order to secure for it the divine sanction of the ancestor (see Wielenga 1909c:371). In matters that concerned only their own particular spheres of influence, however, it seems the *maràmba* acted mostly independently of the *ratu*. Thus the secular leaders, by contrast to the spiritual leaders, can be said to represent segmentary interests.¹⁰ This, too, finds expression in spatial terms. In accordance with the superiority of Palai Malamba to Watu Pelitu, the former clan occupied the upstream (*kambata*) and the latter the downstream (*kiku*, 'tail', see Chapter II) section of the chief village; and since all commoner clans in Umalulu (except for a group of four, which I shall mention further below) stand under the dominion of one or the other of these two noble clans, their houses, also, were located in one or the other of the two outer sections.¹¹ Accordingly, Palai Malamba and Watu Pelitu govern respectively the upstream and downstream halves of the entire territory of the domain.

As is consistent with their separation from secular concerns, the four *ratu* clans, occupying the central section of the village, do not figure in this dual division of the territory. While they have agricultural lands outside the village, these are found in the upstream half of the domain, controlled by Palai Malamba (a fact that further indicates the close association between this noble clan and the senior *ratu* Watu Waya); so the *ratu*'s sphere of influence is confined to the chief village itself and then specifically to the centre. As accords with their occupation of the outer sections of the village, the nobles, on the other hand, are mainly concerned with external affairs, which in former times included the defence of the village, and especially the centre, against attack, and waging war on other domains. The latter activity, as I was told, was one means by which the nobles accumulated wealth in the form of slaves and goods, and so in this respect became vastly superior to the *ratu*. The *ratu* and the *maràmba* may therefore be characterized as oriented upwards and outwards respectively: the former are concerned with 'vertical' relations between man and spirit, and the latter with 'horizontal' relations among groups of men. This formulation, it should be noted, agrees with what was said in Chapter VI regarding the elder and the younger brother in general.

In accordance with the values attached to the three main parts of the village as discussed in Chapter II, therefore, the spatial arrangement of groups within the chief village of Umalulu expresses both the superiority of the *ratu* to the *maràmba* and that of the senior to the junior *maràmba* clan. The former relation, however, pertains mainly to ritual, for in terms of worldly power, the nobles, with their many slaves and clients, greatly overshadow the religious leaders. Also, since about the beginning of the last century at least, Watu Pelitu has come to exceed Palai Malamba in wealth and power; hence it was the Watu Pelitu leader who was appointed principal administrator of the Umalulu district by the Dutch. As regards secular concerns, then, the order of precedence among these groups is precisely the reverse of what obtains in the framework of spiritual values. Yet it is generally clear that for the eastern Sumbanese the spiritual is ultimately superior to the temporal — indeed, what can be called the spiritual (in this case especially the ancestor, Umbu Endalu) is the source of both sorts of powers — so it is this principle that governs the order expressed both in myth and in the arrangement of the village. The Umalulu people thus say that the *ratu* is the superior of the two sorts of leaders, and that they are the one party to whom the nobility must pay heed.

Much of what has been said above concerning the *ratu* refers specifically or especially to the principal member, Watu Waya, and I have yet to discuss how the four *ratu* clans are distinguished among themselves. The groups comprise two pairs: Watu Waya and Muru Uma, and Ongga and Marapeti. The former pair is superior to the latter, and Watu Waya and Marapeti are the senior members of their respective pairs. I found little in myth concerning genealogical connexions among the four clans. However, while Marapeti and Ongga appear to be unrelated to the other pair and thus of external origin, the founder of Muru Uma seems to have been a patrilineal descendant of the Watu Waya ancestor, since this group, I was told, was originally a lineal segment of the principal *ratu* clan. In addition, according to myth the name Muru Uma, '(people of) the green house', actually refers to the first house built in Umalulu by the ancestor of Watu Waya.

By contrast to the other two *ratu*, in ritual matters Watu Waya and Muru Uma are expected only to take decisions and to issue instructions. Since they are thus characterized as passive not only in the secular but in the ceremonial sphere as well, the passivity of the *ratu*, indicated by phrases cited above, refers specifically to these

two groups. Hence the division of active and passive between the two pairs of *ratu* clans replicates that between the *maràmba* and the *ratu* as a whole. The fact that Muru Uma is assigned the special task of summoning (*paaungu*) the other clans of the domain to attend collective rites which concern the *uma nda pataungu* might be taken as an indication that this clan is marginally more active than Watu Waya. But otherwise there is little difference in function between the two; and I suspect that the main reason they are distinguished is simply to effect a quadripartition of the *ratu* clans. The more active role in ceremonial life, therefore, is taken by the junior *ratu*, in particular by Marapeti; so once again, superior and inferior are contrasted as inactive and active respectively. In Chapter V, I recorded the expression *matimbilu halela, mahapangu halimu*, 'the one who rises lightly, and dams off with ease', as a reference, *inter alia*, to the clan ancestor conceived as an active intermediary spirit between man and God. Since the senior *ratu* are designated in the same way as is God, it is significant, then, that Marapeti, as the active religious authority, is also called by this expression.

The active role of Marapeti is most clearly shown by the duties it holds in respect of the *uma nda pataungu*. This clan leads the actual renovation of the building and gathers animals for slaughter from the other clans of the domain. Together with Paraina Bakulu, a prominent commoner clan affiliated with the noble clan Palai Malamba, men of Marapeti further serve as *paratu*, 'those who act as *ratu*, deputy *ratu*', a duty that involves completing the thatch along the roof ridge and transporting the ancestral relics to and from the house.¹² In addition, it is the senior man of Marapeti who performs the various invocations on this occasion.¹³

The fourth *ratu* clan, Ongga, which is no longer extant, formerly stood under the auspices of Marapeti. The two groups are distinguished as the hot and cool *ratu* (*ratu mbana* and *ratu maringu*), which in part is consistent with the fact that Marapeti holds the powers of the 'cool water' (*wai maringu m̀anjaku*, see Chapter V). That Ongga is described as hot refers to its reputed possession of witchcraft powers and the ability, deriving from its ancestor, to control a variety of malevolent spiritual forces. In times of war, therefore, the *ratu* would invoke the Ongga ancestor in order to bring disaster to an enemy and to render them impotent.¹⁴ By virtue of their excessive power, however, the Umalulu people also regarded members of Ongga, whom they speak of as witches, as a potential threat to the community itself.

Thus whenever they became too numerous, the noble rulers would have them killed or sold as slaves, an undertaking called 'plucking off the leaves, reaping the branches' (*hàpiya na runa, mutiya na laina*) and 'dividing (or reducing) the old tubers' (*lowaru lita papandaungu, luwa papandaungu*). It is from this practice that Ongga is usually known as the *ratu hàpi*, 'the plucked *ratu*'.¹⁵ In order that the clan might continue, either two persons were spared or a slave couple was put in their place, in which case, I was told, their names were changed so as to identify them as witches.¹⁶

With regard to Ongga's reputation, it is useful briefly to return to myth. After several attempts to deceive Kàbalu, the earlier occupant of Umalulu, had failed, Umbu Endalu invited Kàbalu and Kaluu Rihi, the Watu Waya ancestor, each to ask the land four times who was its rightful owner. Beforehand, however, Umbu Endalu had hidden the Ongga ancestor, i Kundu i Mbala, in a crevice in the ground at the centre of the present chief village. Thus when Kàbalu called out there was no reply, but when Kaluu Rihi's turn came he received the answer four times that the land was his. That the Ongga people are thought to be witches, then, is consistent with the association, revealed in this myth, of their ancestor with the earth. His hiding beneath the ground is particularly reminiscent of the former practice of casting the bodies of slain witches in a crevice, and the association of such places with malevolent earth spirits, which the Ongga ancestor is able to control.

At this point it is appropriate to consider the relation of spiritual and temporal leadership in Umalulu in the light of evidence which suggests that the authority of the *ratu* was once less confined to specifically religious concerns than is the case at present. Here we might recall again the common eastern Indonesian theme that secular power was usurped by or otherwise transferred to a younger party by an older one who then retained only spiritual authority (see van Wouden 1968:61, 75,140-1; Fox 1968:131). It is useful to begin with the phrases *ina konda, ama ratu*. *Ina* and *ama* are 'mother' and 'father', while *konda* is listed by Kapita (1974) as 'king, sovereign' and 'monarch'. In Umalulu, the expression is sometimes used to refer to the paramount ancestor, Umbu Endalu, in which case it might be glossed as 'mother and father of the nobility and the *ratu*'. But it is also applied specifically to the *ratu*; so in this context a more suitable translation would perhaps be 'mother *konda*, father *ratu*'. The fact that the term *konda*, which apparently refers to the noble rulers,

should thus be used to designate the religious leaders can be ascribed to the idea noted above, that the *ratu*, like the common ancestor of the nobles and the religious leaders, represent a unity of power. This further suggests that the *ratu* may in a sense be regarded as both *ratu* and *maràmba*.¹⁷ In this connexion it is worth noting what an elderly Rindi man had to say about the word *konda*. While it is generally synonymous with *maràmba*, he claimed, the term refers not to the present nobles of Umalulu (Watu Pelitu and Palai Malamba), but to the *ratu* Watu Waya, whom he described as the 'oldest, elder nobility' (*maràmba mamaaya*). He then added that in earlier times the *ratu* and *maràmba* were 'united, undivided' (*mbulungu*) but later became separated.

Further indications that the relation of the two sorts of authorities has (or is thought to have) undergone major changes are to be found in myth. Thus it is said that long ago a violent quarrel developed between the two Umalulu noble clans concerning with which of them a number of clans newly arrived in the domain should become affiliated; and as a result a son of each of the founding ancestors of the noble clans was killed. The *ratu* then undertook to arbitrate the dispute, and ordered that the two victims be buried in the centre of the village. But the Watu Pelitu nobility, interpreting certain of the *ratu*'s decisions as an exoneration of Palai Malamba, left the village to return to their former settlement in Kanatangu. As there was then no one to occupy the downstream section of the village, it was later decided to recall them; and in order to prevent any further strife between the two noble clans, and to ensure that the neutrality of the *ratu* could not again be called into question, the latter assigned a group of four non-aligned clans — Mamboru, Matalu, Kadumbulu, and Ana Mawa — to occupy the *manggawa*, 'space between'. This is the name of a part of the village located to one side of the central section (*kàni—padua*) occupied by the *ratu* and close to the downstream section occupied by Watu Pelitu and its subject clans (see Kapita 1976b:83). The quartet is therefore regarded as a buffer and a mediating force between the two powerful noble clans, and in ritual speech is designated as 'those placed between the tusks, at the divide of the horns' (*da mangiangulu la manggawa uli, la paberi kadu*) and the 'left wing, right wing' (*kàpa kalai, kàpa kawana*), referring to the fact that their attention is divided between the two *maràmba* clans located at either end of the village.

By way of this modification, then, the *ratu* abrogated what was

evidently a formerly more active political role in favour of these four clans, and in doing so further separated themselves from the agnatically related noble clan Palai Malamba. Thus their influence came to be focused entirely within the spiritual order, identified with the centre of the village. In addition, the *ratu* at this time assigned to each of the two noble clans a group of four commoner clans to serve as their special supporters (*tulaku paraingu*; see Section 4 below) and to take up residence with them at either end of the village.¹⁸ Since it is with the names of each set of four clans that each of the *maràmba* is designated in formal speech, their own clan names never being mentioned in this context, the two quartets thus came to take the place of the noble clans in the formal representation of the structure of the domain. In the original organization of the Umalulu chief village, I was told, besides the four *ratu* in the centre, Palai Malamba resided with another clan, Mbuu, in the upstream section, and Watu Pelitu with the clan Palamidu in the downstream section, thus making a total of eight groups. By means of the reorganization just described, therefore, this older configuration was transformed into a sixteen-fold division comprising the four *ratu*, the four clans at the *manggawa*, and the two sets of four *tulaku paraingu* representing the two *maràmba*. If in this latter case the *kàni—padua*, occupied by the *ratu*, is counted with the *manggawa*, then in both arrangements the combined total of groups occupying the two outer sections is the same as that in the middle of the village, i.e., four and eight respectively. This fact might be interpreted as reflecting, symbolically, the previously-illustrated equivalence of the centre and the whole and hence the idea that the *ratu* symbolize the unity of the domain. As I have frequently remarked, four, eight and sixteen can equally stand for unity and completeness. Thus in both the older and the newer arrangement the constitution of the domain reflects a balance, which in the former was disrupted by the departure of Watu Pelitu. In order to restore equilibrium, however, it was necessary not only to recall Watu Pelitu, but, for political reasons, to assign a further four clans — those at the *manggawa* — to ensure that the balance would not again be disrupted. Yet by itself, this would not have been sufficient, for then there would have been eight clans in the middle but a total of only four at the two ends. Viewed in this light, therefore, the appointment of the two sets of four clans to represent the noble rulers acquires additional significance.

Thus far I have shown that the offices of *ratu* and *maràmba* are

distinguishable in terms of the following contrasts: religious authority/worldly power, elder/younger, centre/periphery (or inside/outside), and passive/active. As a conclusion to this section, therefore, we should consider two further symbolic oppositions which, though not so pronounced in this case, are often linked with comparable forms of dual leadership in eastern Indonesia. The first is that of masculine and feminine. As van Wouden (1968:62-3, 105, 115, 141) has shown, this contrast is commonly employed on Timor and elsewhere to distinguish political rulers from figures comparable to the *ratu*, though which power is assigned to which gender category varies from case to case. While the idea appeared not to be widely known, in eastern Sumba I was told that the *maràmba* were masculine and the *ratu* feminine, a characterization which, as among the Atoni (see Cunningham 1965:367, 371), would seem to express the respectively active and passive qualities of the two sorts of leadership. However, despite this apparent concordance, other aspects of the two offices suggest the inverse classification. Thus as was demonstrated earlier, especially with regard to the internal order of the house, in other contexts it is the spiritual that is masculine and the temporal that is feminine. Evidently, therefore, the attribution of symbolic masculinity to the noble rulers has validity only within what can be called a framework of worldly or temporal values, according to which, as was shown in Chapter I, the feminine is connected with the inside and the masculine with the outside. Expressed in another way, then, the idea that the *maràmba* are masculine appears to refer specifically to their superiority in secular and external affairs.

Another common theme in eastern Indonesia is the association of spiritual and secular leaders, or parties distinguished as older and younger, with the earth and the sky (see van Wouden 1968).¹⁹ That this also obtains in eastern Sumba is immediately suggested, on the one hand, by the derivation of the *maràmba* class from a woman who descended from the heavens and, on the other, by the designation of the Umalulu *ratu* as the 'owners of the land' (*mangu tanangu*). Another link between the *ratu* and the earth is apparent from the case of the clan Ongga. Yet as noted above, the title of *mangu tanangu* in Umalulu is sometimes applied to the *maràmba* clan Palai Malamba as well as to the *ratu*, and taking eastern Sumba as a whole one finds that this office and that of noble ruler are not always separated. A more serious difficulty, however, is that, like the opposition of masculine and feminine (which parallels that of sky and earth), the apparent

association of the *maràmba* with the above and the *ratu* with the below which this contrast suggests is not compatible with others that pertain to the two offices. Thus, as I have shown, the elder brother is associated with the centre, the inside, and the cult of the ancestor, who in turn is connected with the above, i.e., the higher sections of the house and the sky, while the younger brother is then linked with the outside and the earth (see Chapter VI).²⁰ I would suggest, therefore, that the association of the nobles with the sky (and the above) refers specifically to their apical position within the hierarchy of class rather than to their opposition to the *ratu*. Here it is relevant to point out that whereas the term *maràmba* denotes both a social class and a political function, *ratu* refers to a purely hereditary office assigned to patrilineal clans that in many respects falls outside the framework of class stratification, which concerns only the distribution of temporal power. Thus while the maintenance of marriage ties with groups of like rank is crucial to the standing of the noble clans, alliance is of limited importance to the *ratu*. Though the religious leaders of Umalulu preferred to marry with *ratu* clans of other domains, it seems this has never been insisted upon; and, as I was told, the *ratu* may even take wives from among the nobles' slaves without their position being in any way compromised. The difference in the significance of matrilineal alliance and patrilineal descent for the *ratu* and *maràmba*, then, accords with the spiritual nature of the former's office, which is based on a special relation with a patrilineal ancestor, and with the orientation of the noble rulers towards external, secular concerns, in which marital alliance, as a means of forging or consolidating links between independent domains, and in the case of Umalulu between the two halves of the domain itself, plays an important part.

2. *Mangu Tanangu*

Before turning to the division of spiritual and secular authority in Rindi it is useful to discuss the *mangu tanangu*, 'owner of the land', or in ritual speech *ina mangu tanangu*, *ama mangu lukungu*, 'mother (owner) of the land, father (owner) of the river', a figure comparable to the 'lord of the land' (Indonesian *tuan tanah*) found elsewhere in Indonesia.²¹ Throughout Sumba, as in eastern Indonesia generally (see van Wouden 1968:28, 49, 61, 141), the title belongs to the group that was reputedly the first to take possession of a territory; and often the office is separate and distinct from that of (political) ruler.²²

Within eastern Sumba alone, however, the position of the *mangu tanangu* varies considerably between domains; and while in Umalulu it is ordinarily the *ratu* who are designated as *mangu tanangu*, contrary to the generalizations of earlier writers (Wielenga 1909c:371-2; Couvreur 1917:216-17), not everywhere is this the case. Thus in Mangili, *mangu tanangu* is the collective title of the four clans Mâru, Watu Bulu, Matolangu, and Wanggi Rara, whose ancestors founded the present domain. Of these, the first three are of *marâmba* rank and the first two were formerly the secular leaders; while the fourth clan, an aboriginal group that is now extinct, once held the ceremonial office of *ratu wai ndaungu*, 'ratu of the year water (i.e., the rain)', which was later assigned to a segment of the clan Marapeti, originally from Umalulu (Onvlee 1949:447; Kapita 1976b:111). In Kapunduku, to cite another variation, the title of *mangu tanangu* belongs to a clan other than that recognized as *ratu*, and both are distinct from the clan of the noble ruler (see Adams 1970:84). Thus while *mangu tanangu* always refers to the oldest group(s), clearly not everywhere is this party simultaneously or exclusively the *ratu*, nor is the *ratu* always *mangu tanangu*. Furthermore, while the office of 'owner of the land' appears to be based simply on temporal precedence, that of *ratu* seems to presuppose a system of diarchical leadership requiring the complementary position of *marâmba*, which, in some cases at least, is founded upon a shared agnatic connexion with a single ancestor.

All land, whether or not in use, falls within the jurisdiction of a *mangu tanangu*. In Umalulu it was this party, the *ratu*, who first divided the lands among the ancestors of the clans earliest established in the region. Within their respective territories, these other clans are also called *mangu tanangu*,²³ although the *ratu* are regarded as *mangu tanangu* of the entire domain. Each of the smaller territories is then shared with a number of tenant groups, more recently settled in the domain.²⁴ Since the rights of the *mangu tanangu* in eastern Sumba are no longer recognized by the government, however, their traditional role is now largely defunct. Moreover, it seems that this decline is not entirely of recent origin; for Roos, in his report of 1872 (pp. 4-5), states that while permission should be obtained from the *mangu tanangu* before land is used, the obligation is seldom observed.

The position of the *mangu tanangu* in Rindi is rather different from that found in Umalulu. Parts of the present territory were previously held by the Umalulu clans Palamidu and Pakilungu, and

so formally still fall within the jurisdiction of the *ratu* of that district. The largest and more central area of the domain, however, is divided between the two *mangu tanangu* clans Rindi and Dai Ndipi, which traditionally, I was told, were not subject to Umalulu. The original possessor of the combined territories of the two clans was Rindi, which later ceded a portion of its territory to the ancestor of Dai Ndipi, when he arrived from Savu. The present territory of the clan Rindi comprises the lands on both sides of the river Rindi from the estuary to just past Parai Yawangu. Although this clan is now locally extinct, and the Ana Mburungu nobility to all intents and purposes exercise rights to the land they occupy in this vicinity independently of any other group, the clan Rindi is still spoken of as the *mangu tanangu* of this region. The land of Dai Ndipi, on the other hand, lies further upstream and extends southwards towards Mangili. The most important difference between the *mangu tanangu* in Rindi and their counterparts in Umalulu, however, is that neither the clan Rindi nor Dai Ndipi bears the title of *ratu* or occupies any other special position within the domain as it is presently constituted. Probably due mainly to the fact that the present inhabitants moved into this region only relatively recently, moreover, the *mangu tanangu* clans of Rindi formally ceded lands to none of the clans that subsequently settled there. Thus all of the latter can be called tenants.

Concerning the traditional rights of these tenants I received the following information. A payment of two horses and two metal pendants with chains established a tenant clan's hereditary right permanently to occupy and use an area of land. Since the name of this prestation, *huluku pahàpa*, 'offering and chewing ingredients', also denotes a prestation given to another clan whose ancestor is invoked for some ritual purpose (see Chapter V), evidently it was primarily intended to secure the patronage of the landowning clan's ancestor, the *marapu mangu tanangu*. A similar payment was required when a new village was founded or a large gravestone quarried. The *mangu tanangu* had also to be notified before large trees were cut for house posts, but this seems not to have required any compensation. An area of agricultural land given over to a tenant was only loosely defined, and with the *mangu tanangu*'s consent fields could later be laid elsewhere as the group expanded, provided no other party had established a prior usufruct. While the tenant clan had first to give its consent if a third party wished to borrow a plot, I was told that the permission of the *mangu tanangu* was not required in this case.

When the land was later abandoned, the usufruct reverted to the tenant. Nowadays such matters are referred to the elected village (*desa*) and district (*kecamatan*) officials.

In return for land use, tenants were obliged to surrender annually to the *mangu tanangu* a small portion of produce, called the *kandau tana*, *kapuka rumba*, 'residue of the land, tip of the grass'. I was unable to ascertain whether this was owed by individual cultivators or by entire clans. Though one small basket of rice was mentioned as typical, the amount varied with the yield, and in a poor year it could be dispensed with altogether. The *kandau tana* was collected after the dry rice harvest in May or June, and the *mangu tanangu* would then offer a portion to their ancestor in order to request a good harvest in the following year. The rite concerned this clan alone. Some of the rice was also offered at the first fruits ceremony (*ngangu uhu*) held by the *mangu tanangu* clan, for which undertaking they could further require tenants to provide animals for slaughter, a right that falls under the previously mentioned category of *mangapangu*. But since the first fruits ceremony is performed by all clans individually, this too cannot properly be called a communal rite. The *mangu tanangu* clan does not regulate the agricultural calendar, nor does it lead or play any part in minor agricultural rites that specifically concern the fields of individual tenants.

Although the use to which lands were put was mostly left to the tenants themselves, in the ways indicated above the prior, albeit largely passive, regulation of land use lay with the *mangu tanangu*. This party also defined which areas could be turned into fields and settlements and which could not, especially those proscribed as 'hot land' (*tana mbana*). The *mangu tanangu*'s authority in this respect derives from the group's recognized superior esoteric knowledge of the ways of the land, which, of course, is a function of their having occupied the territory the longest. The *mangu tanangu* was thus entitled to exact compensation for breaches of custom concerning the land. It is forbidden, for example, to produce salt or lime during the rainy season, as this would cause drought and crop failure. Since these activities are carried out at the estuary and on the coast, in Rindi it was the clan of that name, as *mangu tanangu* of this region, which enforced the rule. They would confiscate the salt or lime, and, in the case of a second offence, could demand a fine, paid in horses and metal goods.²⁵ In Umalulu, the rule is enforced by the *ratu*, in particular by the clan Marapeti.

The traditional authority of the *mangu tanangu* thus concerns only matters relating to the use and well-being of the land, and they are not in any sense political rulers.²⁶ As elsewhere in eastern Indonesia, therefore, it seems the office is primarily of a spiritual or religious nature, which is consistent both with their being the oldest occupants of the land, and with the combination, in some districts, of the office of *mangu tanangu* with that of *ratu*. Several expressions applied to the *mangu tanangu* indicate an especially close relation with the land. Among these are the phrases *na matanangu na tana*, *na malukungu na luku*, which, though difficult to translate exactly, convey the sense of '(those) who make (made) the land and river what they are' or '(those) who have (or use) the land as land, etc.'²⁷ It is important to note, however, that all such designations, and indeed the title *mangu tanangu* itself, refer as much to the ancestor as to the living members of the clan, since it is this personage who forms the essentially mystical link between the clan and the land. Thus while the office of *mangu tanangu* has virtually disappeared in Rindi, when tenants perform a variety of agricultural rites they always dedicate a fowl to the ancestor of this clan in order to ensure the success of the crop. The fact that payments made by tenants are, as I have shown, more in the nature of offerings to this deity than of tribute or rent to an overlord further suggests the spiritual character of the *mangu tanangu*. Accordingly, although this party's right to the payment called *kandau tana* need no longer be honoured, I was told in Rindi that some cultivators in the territory of Dai Ndipi still give it on a voluntary basis. The only conceivable reason for their doing so, then, is to secure the prosperity of the land and the crop from the *mangu tanangu* clan's ancestor.

There is one further point worth making in this regard. Eastern Sumbanese traditional history reveals instances where ceding land to an immigrant clan coincided with this group becoming a wife-taker of the *mangu tanangu* clan or one of its associates. In this context, therefore, land might be viewed as one of the feminine goods provided by a wife-giver (see Chapter XIII), the more so as the payment initially given to the land-owning clan by a tenant consisted of goods of the sort used as bridewealth. As I shall later illustrate, moreover, a wife-giver's superiority is not of a secular or political kind, but is represented mainly in terms of spiritual values. So in this respect too, the relation of the *mangu tanangu* and later arrivals on the land parallels that of the two sorts of affines.

3. Dual Leadership in Rindi

As noted above, an important difference between Umalulu and Rindi is that the office of *ratu* is formally absent in the latter domain. Indeed, the *maràmba* of Rindi adduce this fact as evidence of their superiority to noble clans elsewhere, for unlike these, they say, there is no one to whom they must listen. This does not mean, however, that there is no separation of secular and religious authority in Rindi, but only that it is differently expressed. Specifically, the division is manifest within the Rindi noble clan itself, between the lineages Uma Penji and Uma Jangga. The former, which is the highest ranking of the six noble lineages of Ana Mburungu,²⁸ is the secular leader both within the clan and throughout the domain; thus men of Uma Penji were appointed as the district administrators by the Dutch. As regards ceremonial concerns, on the other hand, greater authority is accorded to Uma Jangga, whose members are in general considered to belong to the lower nobility (*maràmba kudu*).

The apical ancestors of Uma Jangga and Uma Penji were both sons of Umbu Nggala Lili, the common forbear of all noble members of Ana Mburungu (see Fig. 7). Uma Jangga, however, descends from the eldest son of Nggala Lili's first wife, a woman from the Umalulu noble clan Palai Malamba, while the Uma Penji ancestor was a child of a later wife, a noblewoman from Tabundungu. The difference in rank between Uma Penji and Uma Jangga ultimately derives from the fact that the second wife was of somewhat higher standing than the first. (The especial prestige attaching to marriage with Tabundungu noblewomen was noted in the previous chapter.) As their ancestors are distinguished as elder and younger and, in terms of class, as lower and higher, therefore, the relation between these two lineages is precisely the same as that between Watu Waya and Palai Malamba, the principal *ratu* and *maràmba* in Umalulu. Perhaps what we encounter in Rindi, then, is a nascent form of the more developed pattern of dual leadership found in longer established domains.

In its capacity as the ceremonial authority, Uma Jangga is called 'the red jar, the green urn' (*mbàlu rara, kihi muru*). The phrases also refer to the group's spokesman. Traditionally this was the most senior man, but it has more recently become the practice among the nobles to appoint someone of Uma Jangga (or the derivative lineage, Uma Kopi) to fill the position by virtue of his individual ability and knowledge of custom. At present this person is ordinarily known as the

kapala huri, 'ceremonial leader' (*kapala* is borrowed from the Indonesian *kepala*, 'head, leader, chief'). It is he who presides over all major ritual undertakings that concern the noble clan (and hence, often, the domain as a whole), and meetings at which preparations for these are discussed take place in Uma Jangga's principal house. Significantly, the only meaning I could find for the phrases 'red jar' and 'green urn' was as a reference to two vessels kept in the *uma nda pataungu*, the house consecrated to Umbu Endalu in Umalulu; the latter container, I was told, holds the relics of this ancestor. Since the vessels clearly represent a source or focus of spiritual power, it seems therefore that the position of the ceremonial authority in Rindi, while different in certain respects, is conceived analogously to that of the Umalulu *ratu*.

As in Umalulu, the separation of secular and ceremonial authority in Rindi is reflected in the spatial organization of the chief village. In this respect, though, there are significant differences to be noted between the two domains. In the centre of the Rindi chief village, on the principal side of the settlement, are found two named houses, Uma Bokulu (also called Uma Haparuna) and Uma Ndewa (see Fig. 3). The former of these, which was the first to be built in Parai Yawangu, is the common ancestral house and clan temple for all lineages of Ana Mburungu. As the extensive renovation of this large building begun in the last decade has yet to be completed, the house now stands empty. But it seems that for some considerable time prior to this, as well, Uma Bokulu was occupied only by slaves; thus while most ceremonies that concern the clan as a whole are centred in this house, the various noble lineages have for a long time kept residence in separate houses of their own. In a way analogous to what is found in Umalulu, therefore, the oldest house, located in the superior central section of the village, represents the common derivation of leaders distinguished in terms of spiritual and temporal authority.

Although the Rindi have no house identical to the Umalulu *uma nda pataungu*, they sometimes claim the Uma Ndewa, reputedly the second house to be built in the chief village, to be its local counterpart. Indeed, in addition to the fact that both are located in the central sections of their respective villages, the two buildings are similar in that Uma Ndewa, too, is not a residential house and may only be entered when rites are held there. Formerly, the building was occupied and attended by a single woman of slave rank,²⁹ while at present it stands empty. Though the Uma Ndewa is now built to the

same size as the senior houses of some other clans, in one respect the construction is simpler,³⁰ and in the past, I was told, it was made smaller and ruder, so that it might regularly be renovated as part of a major ceremony similar to that which accompanied the renovation of the *uma nda pataungu*. Yet the Uma Ndewa differs from the latter in that it is principally used for major rites that concern the powers of *ndewa-pahomba* (see Chapter IV), thus indicating an association with a more diffuse and amorphous representation of divinity than that associated with the Umalulu house. It is worth mentioning, however, that some informants connected (albeit rather vaguely) the relics kept in the Uma Ndewa with the father of the noble clan's founding ancestor, whose place is in the Uma Bokulu. This suggests, then, that this figure and the common ancestor of the *ratu* and *maràmba* of Umalulu are not entirely dissimilar.

The house of Uma Penji, the temporal leader in Rindi, is found at the upstream end of the village, while that of Uma Jangga, the ceremonial authority, is placed at the downstream end, both in the principal row of houses (see Chapter II). That the ceremonial authority should apparently occupy the inferior of the two outer sections thus suggests an important difference between the organization of the chief villages in Rindi and Umalulu; and it is in accordance with this that Uma Jangga is not recognized as ultimately superior to Uma Penji in the same way as the Umalulu *ratu* are regarded as superior to the *maràmba*. The organization of Parai Yawangu seems therefore to reflect more the order of temporal precedence, based on the distinction of rank, between the constituent lineages of the noble clan. But there is another way in which this arrangement might be interpreted. As noted, the lineage most closely identified with the downstream extremity of the settlement (in part because it is the one responsible for the gate altar placed at this end of the village) is not Uma Jangga but Uma Wara (see footnote to Section 2 above), which, appropriately, is the lowest ranking of all the six noble lineages. In this respect, the distinction of the two sides of the village is relevant, since the house of Uma Wara is located in the inferior row (the one facing the sunset), thus opposite that of Uma Jangga. The house of Uma Jangga, moreover, stands right next to the Uma Bokulu; so its position could alternatively be viewed as an expression of the special relation between this group, as the ceremonial leader, and the clan temple, rather than in opposition to the location of the house of Uma Penji. Uma Penji appears to have been the first lineage to leave the clan's senior house;

and even before it founded its own residential house, I was told, the nobility of this group dwelt not in the Uma Bokulu but in the nearby hamlet of Kulu. Significantly, then, the lineage vested with the highest worldly authority was the earliest to separate itself from the house that is the main focus of the clan's religious life.

4. *Tulaku Paraingu and Mbapa Tunu Manahu*

The office of *tulaku paraingu*, *lindiku maràda*, 'supports of the chief village, props for the plain', or, as it is also designated, *ai ngaru pindu*, *watu la hanamba*, 'posts of the gateway, stones at the house front', was mentioned briefly in Section 1 above. In Rindi, the title is held by four (or rather two pairs of) commoner clans — Kihi, Kaburu, Katinahu, and Mahora — whose traditional function was to support the nobles in a variety of undertakings, and thereby to consolidate their power and standing both within and without the domain.³¹ At present at any rate, however, this function seems to be more symbolic than practical. Throughout eastern Sumba it is the practice in formal speech to employ the names of four such clans to denote the noble clan with which they are linked. Thus, since only clans which include *maràmba* of the highest rank (*maràmba bokulu*) have the right to be designated in this way, the existence of the four clans is in itself sufficient to exalt the noble clan in question; and it now seems to be largely to this fact that the notions of support and consolidation expressed in the title of the office refer. In Rindi, the names of the four *tulaku paraingu* are also used to denote the domain as a whole. Onvlee (1949:447) describes a similar pattern in Mangili. This, then, provides another instance of the identification of the domain with its ruling nobility.

Noble clans are so closely identified with their *tulaku paraingu* that in Rindi I often found the actual clan name of a noble affine could not be recalled, but only those of the associated quartet. Elderly men would also sometimes refer to a noble clan with the name of just one of these four, usually the first mentioned in the series.³² These practices therefore accord with the general principle whereby a highly revered entity is designated or addressed indirectly through a subordinate or mediator. The relation of the *tulaku paraingu* and the formally anonymous noble clan also reveals an instance of the previously-illustrated configuration in which four peripheral elements are subordinated to one occupying a centre. As this case shows, the

relation between the central element and the peripheral four is one of equivalence and identity, the latter being simply an immediate and articulated representation of the former. Accordingly, with this pattern there is no mention of the number five; the one and the four are equally expressions of unity.

This instance of quadripartition, however, must further be seen in relation to the more general practice in formal speech whereby any single clan is designated with a set of names comprising its own and those of three others (see Chapter XII). Such a quartet is more accurately described as two pairs, and while four names is considered the complete form, often only the pair which includes the clan's own name is used. Thus it was explained to me that, strictly speaking, the title *tulaku paraingu* applies only to the senior pair of this quartet, Mahora and Katinahu, and then specifically to Mahora — Kihi and Kaburu being little more than 'paired terms' (*ndekilu*) whose names are added simply to complete the quartet. Indeed, other than in a nominal sense, these latter two clans do not maintain any particular relation with the nobles, whereas Mahora, and by association Katinahu, are substantially connected with them. Both include members of higher commoner rank and, apart from the noble clan itself, are the most prominent, and among the wealthiest, clans in the domain. Mahora in particular provides the nobility with accomplished ritual speakers (*wunangu*), and because by tradition its members are knowledgeable in customary matters, they also serve them as ceremonial advisors. Mahora is thus especially linked with Uma Jangga, the noble ceremonial leader, in relation to whom the clan is called the 'pole onto which to grasp, plank on which to lean' (*punduku paàpa, kapapa ai haria*).

The present relation of Ana Mburungu and Mahora is reflected in myth. It was the ancestor of the latter (an expert ritual speaker, part of whose name, Tarangu Langu, means 'clear speech') who obtained the wife of the noble clan's ancestor for him. Since the Mahora ancestor holds the power of the 'cool water' (*wai maringu mànjaku*), moreover, a childless forbear of Uma Penji once ritually invoked the patronage of this ancestor in order that his wife might bear children. This, then, is an instance of the institution of *paatangu wiki*, 'to subordinate oneself', mentioned in Chapter V. Although the two groups are not related by marriage, it is worth noting here that this sort of service is often provided by a wife-giver. After moving to Mahora's ancestral house, the nobleman's wife gave birth to a son. Further

to secure the auspices of the Mahora ancestor, Uma Penji then placed a portion of the relics consecrated to this personage in their present principal house, which was founded about this time; so all invocations performed in this building at present are addressed to the Mahora ancestor. By virtue of this arrangement, the Mahora people now claim that they (which is to say, their ancestor) 'made (makes)' (*pandoi*) and 'created (creates)' (*wulu*) the noble lineage. In this respect, therefore, Mahora is recognized by the nobility as a group which possesses superior spiritual power.

The above remarks illuminate Mahora's private — and somewhat irregular — claim that they are the *ratu* of Rindi. (At the same time, however, they recognize that the position they assume is different from that of the *ratu* in Umalulu.) While the nobles deny their claim to this title, I was moreover told by various informants that shortly after the present chief village was founded, the Ana Mburungu nobility requested Mahora, who were already present in the district at the time, to join them there and to fill the office of *ratu*. Reputedly from fear of becoming too dependent on the nobles, however, they declined, and so moved from their earlier settlement at Mau Wunga, a short distance from Parai Yawangu, to their present village at Kanoru, about four kilometres upstream. It was apparently in connexion with their refusing the office of *ratu* that Mahora was then included among the four *tulaku paraingu*.

To complete this description of the present constitution of Rindi I should also mention the office of *mbapa tunu manahu*, the 'partners in roasting and cooking', or 'ceremonial partners', of the nobility. The title is given to a group of six clans:³³ Maritu, Ana Kapu, Karindingu, Mbara Papa, Mburu Pala, and Marada Witu. As I shall elaborate in the next chapter, the relation between these clans and the Rindi noble clan is consistent with a putative agnatic connexion between their apical ancestors. I was also told that the first four members of this group were the original *tulaku paraingu* of Ana Mburungu before the latter established itself as the ruling clan in Rindi, whereupon they were replaced by Kihi, Kaburu, Katinahu, and Mahora. At present, the function of the *mbapa tunu manahu* is a purely ceremonial one. The headmen of each of these clans, elaborately adorned in the finest textiles and jewelry, must guard the relics of the noble houses Uma Bokulu and Uma Ndewa, which are placed in a small hut, when one of these buildings is renovated. Just after the old thatch is removed and again before the new thatch is tied in

place, they also ascend to the roof of the house, where they remain seated for a while at the foot of the peak. In this way, then, they appear symbolically to replace the thatch as something that covers and protects the relics (and thus, in a sense, the ancestor) which are normally kept in this part of the building. The Rindi commonly refer to the *mbapa tunu manahu* as *paratu*, 'those who act as *ratu*'. As noted, this title is also found in Umalulu; and although there it has a slightly different import, referring to the *ratu* clan Marapeti and one of the *tulaku paraingu* of Palai Malamba, the functions of the *paratu* in the two cases, since both concern the renovation of spiritually important buildings, are thus essentially similar.

There are some grounds, then, for distinguishing the *mbapa tunu manahu* and *tulaku paraingu* as ceremonial and secular offices respectively. Consistent with this is the fact that whereas the latter represent the noble rulers, the former complement them, and so resemble the *ratu* elsewhere. In this regard, it is interesting that the Rindi nobility denied that the *mbapa tunu manahu* clans were properly called *paratu*; for this contention was shown to be motivated by the close resemblance between this title and that of *ratu*, the latter being an office the Rindi nobility do not recognize.³⁴ What one apparently encounters in Rindi, therefore, is a domain which, in contrast to others, is dominated by its ruling nobility to the exclusion of independent groups that can claim religious or ceremonial authority in their own right.

5. Authority within the Village and Clan

The instances of dual leadership discussed so far all concern the domain as a whole. In this final section, therefore, I shall consider religious and secular authority within the individual village (*kotaku*) and clan. (I refer here of course not to the noble clan but to the commoner clans in Rindi.)

The statement by Roos (1872:5) that there are no village chiefs on Sumba agrees with the situation in Rindi insofar as a village lacks any formal office of secular leader. When several clans share a single settlement, however, the oldest of these, i.e., the village founder, is specified as the *mangu kotakungu*, 'possessor of the village'.³⁵ Since this party's primary task is to organize, though not necessarily to officiate in,³⁶ collective rites that concern the village altars, it is also called the *mangu katodangu*, 'possessor of the altar(s)', referring

especially to the yard altar, which usually stands before the oldest house. As the pre-eminence of this group is expressed in the ceremonial sphere, its position within the village is thus analogous to that of the *mangu tanangu* within the wider territory. With regard to worldly affairs, on the other hand, the village founder can claim no special authority, and often other resident clans are more influential in this respect. But since this is not invariably or necessarily the case, we must conclude that there is no formal division of religious and secular authority between distinct resident descent groups within single villages in Rindi.

The exclusively ceremonial nature of the responsibilities of the oldest clan is largely a function of the fact that matters that equally concern all members of a village are mostly of a ritual nature. Secular affairs, on the other hand, tend more often to be the concern of individual clans. As with regard to the domain as a whole, therefore, it can generally be said that religious or ceremonial activities involve larger groups than do purely secular ones;³⁷ and, as I shall demonstrate in the next chapter, this principle applies also to members of a single clan.

As with regard to different clans that occupy the same village, religious and secular powers are not formally divided between different component groups of single (commoner) clans in Rindi. Nevertheless, it is useful to describe the factors that determine how authority is allocated in this context. First, matters that corporately concern all clan members are discussed, and decisions are taken, ideally on the basis of consensus, by the mature men (or male elders, *ama bokulu*) in council. Membership of this group is thus simply a question of age (and sex). Among these elders, however, those belonging to the clan's senior line and, in particular, the eldest man of that line, are accorded the greatest influence; so it is possible to speak of a clan headman who assumes the position of a *primus inter pares* and, in relation to other clans, that of group spokesman. Though the office has no formal title,³⁸ the headman can be distinguished as the 'seniormost elder' (*ama bokulu mamaaya*) or simply 'the elder' of the clan. His position, therefore, is based first of all on seniority of descent; and while there were exceptions (as, for example, when the senior line did not include men of sufficient maturity or when the eldest member of this group was considered personally unfit), the majority of persons recognized as clan headmen in Rindi were indeed the eldest men of the senior line, even when there were older men in the clan at large. Age, then, is a secondary factor in this regard.

By contrast to the pattern found among different clans inhabiting a single village, therefore, the clan leader, i.e., the headman and in a wider sense the senior line, exercises greater authority in both secular and religious affairs. The headman's religious prominence is of course consistent with the fact that the senior — or oldest — line is the one longest and most closely connected with the clan's ancestral house; thus he is the person chiefly responsible for the cult of the ancestor, and in ceremonies that concern the entire clan, it is he, specifically, who is designated as the 'principal' (*mangu pingingu*, 'possessor of the trunk, source'). With regard to secular activities, on the other hand, the headman's position seems less clearly defined; for as previously shown, in this sphere class standing (and wealth) is of greater importance than is lineal seniority. But we should also recall that the distinction of rank between members of the commoner class (i.e., that between *kabihu bokulu* and *kabihu kudu*) carries rather less weight than that between higher and lower nobility; and in any case, within commoner clans in Rindi the senior line is generally not of lower rank than junior ones, where there is a formal difference of class.

However, since contingently at least, the clan headman is superior to other members in terms of both class and seniority of descent, it is relevant that some facts suggest a tendency for the headman to separate himself from certain specifically religious concerns. Thus, while it is held that the headman should be capable of acting as priest on behalf of the clan, it often happens that he will regularly delegate priestly duties to another clan member or, perhaps more commonly, to someone from another clan, frequently an accomplished priest whose services are widely employed in several villages. As the role of priest normally requires that a person be of an advanced age, apparently this was sometimes done because the headman was still relatively young; but in some cases the priest was not in fact older than the headman. What this seems to involve, then, is specifically a separation of secular leadership or higher rank from direct participation in religious activities, rather than a positive association, within the clan, of religious authority with greater age or with juniority of descent or lower rank. Here, we should again recall that the nobles in Rindi, regardless of age, never themselves act as priests but always have slaves or commoners do this for them. A similar arrangement is suggested by the fact that, while the clan headman is formally in charge of the clan's ancestral house, in several cases he and other

members of the senior group normally resided in another building, and often in another village, thus leaving the oldest house in the daily care of a more junior group.³⁹

Nevertheless, I did come across one context in which a clan religious function was apparently assigned purely on the basis of age. This concerned a rite carried out by a certain clan before removing the relics from their ancestral house prior to renovating the building. Though unfortunately I missed this performance, I was later told that a particular member of the clan was assigned the important ceremonial task of actually carrying the relics; and this turned out to be not the clan headman but the oldest living male member of the clan, the elder of the two men older than the headman, who thus belonged to a junior line.

As with regard to the performance of priestly duties, with which this task seems to be comparable, however, it is important to distinguish here between authorities and functionaries. Thus, while another person may act as a priest for the clan, and therefore exercise a good deal of *de facto* influence in the execution of rites, it is yet the headman who, owing to the special relation between the senior line and the clan ancestor, is formally the principal authority in the clan's ceremonial life; and he is able to remain the final say in how rites should be carried out. In other words, while age, not lineal authority, is the significant factor regarding whether someone is qualified to serve as a priest, this relates first of all to individual age rather than the agnatic framework of relations within a single clan.

6. *Summary Remarks on Bases of Authority*

We are now in a position to draw several general conclusions from the topics discussed in this and the previous chapter. First, the relative importance of the three factors that affect the allocation of authority — age, seniority of descent, and class — varies with the type of authority concerned. Thus, while for spiritual matters one can abstract the order: age > lineal seniority > class, in respect of secular activities the reverse order obtains. In both series, therefore, lineal seniority occupies the medial position, and whether this variable implies religious or secular authority depends on whether it is contextually opposed to class or to age. When it stands in opposition to class, the significant attribute of lineal seniority appears to be its ultimate derivation from a difference of age, whereas when it is opposed to

age it is evidently its formal resemblance to and frequent combination with class superiority that are its relevant qualities. It is also worth pointing out that while in the religious sphere, class (and in some cases lineal seniority) is at best unimportant, in the secular sphere lineal seniority and age are still significant in respect of finer distinctions within categories. Thus among the *maràmba bokulu*, the class of political rulers in Rindi, for example, greater power is accorded to the senior lineage of this section of the noble clan and then to the eldest member of this lineage. Clearly, therefore, age, especially, carries influence in both spheres, while class, it seems, pertains only to secular power. Finally, it should be noted that the dualistic character of authority, particularly the extent to which it is divided between discrete groups, is the more pronounced the higher the structural level in question. It is thus most marked in the relation of *ratu* and *maràmba*, somewhat less so between the lineages of the noble clan in Rindi, and formally absent within Rindi commoner clans (which, with one exception, are not segmented into named lineages). A corollary, then, is that authority is the more unitary, and concentrated in the senior member of a group to the exclusion of juniors, the lower the structural level in question. Thus, to cite the extreme case, among full siblings the eldest is pre-eminent in all respects. With this example in mind, it should further be noted that *aya*, 'elder', and *eri*, 'younger', the eastern Sumbanese equivalents of the relative age terms found throughout Indonesia, are in varying degrees applied in Rindi to distinctions that derive from all three of the variables discussed above, namely to elder and younger siblings (or persons), senior and junior descent lines, and to higher and lower ranks.

CHAPTER XII

DESCENT GROUPS

Although eastern Sumbanese society is composed of groups defined by patrilineal descent, there are circumstances in which a person can be incorporated into a patrilineal group other than that of his legal father or father's father. Hence patrilineages in eastern Sumba do not quite measure up to the strict definition of a (unilineal) descent group advocated by Leach (1962:131). Nevertheless, recruitment other than by patrilineal descent is uncommon in this society and occurs only in cases that are in some way exceptional.¹ It does not therefore bear significantly on the topic of descent group organization as such; and since other modes of incorporation are in one or another way a function of marriage practices, they are more appropriately discussed in that context (see Chapter XV). The present chapter is however partly intended as a prelude to an extended discussion of marriage and alliance, and towards the end attention will be given to the involvement of lineal groups in the arrangement of marriages.

1. The Clan

Clans are distinguished from one another by the possession of a distinct name or a distinct apical ancestor (*marapu*). Used in this inclusive sense, 'clan' refers to the highest level of patrilineal descent grouping in eastern Sumba, which typically comprises groups established in several domains. Local segments of larger clans are dispersed throughout the eastern region and some even extend into western Sumba. Thus in many domains a high proportion of resident clans derive from outsiders.² Rindi provides an extreme instance of this pattern, since the great majority of clans resident there descend from immigrants previously established in other districts. But while marriage is prohibited between all persons with the same clan name or *marapu* ancestor,³ a clan spread over several domains is not a corporate group.

Hereafter, then, I shall use 'clan' to refer only to the segments localized in a single domain, or what Needham (1957:170) has called 'major lineages'. Where further specification is required I shall speak of the local clan.

The word for clan is *kabihu*, a term which is also occasionally applied to lower levels of descent grouping, regardless of whether they are distinguished by name. *Kabihu* has the further meanings of 'corner' and 'right angle', in which respect it resembles its usual Indonesian equivalent, *suku*, which can also mean 'leg (of an animal)' and 'quarter'. In parallel speech *kabihu* is conjoined with *nganangu*, 'to plait, plaiting'. Since the common designation of God as 'the maker and plaiter of mankind' clearly suggests plaiting to be an idiomatic way of expressing creation, in this context then *nganangu* seems to express the idea of a clan as a group which in a sense is a separate creation, as it derives from a single deified ancestor who is also regarded as a creator.⁴

A clan name usually has a recognized, translatable meaning, and there is often a myth or, at any rate, a standard explanation to account for it. While this is not the place to outline all the varieties of nomenclature encountered among Rindi clans, it is worth noting that the majority of names show some connexion with the clan ancestor. This, then, again underlines the importance of this personage for the clan's identity, and its significance as a cult group. Some clans take their names from one of those included in the ancestor's formulaic title, or from the name of a forbear closely related to the principal ancestor; while other names refer to an exploit, attribute, or association of the ancestor or ancestors. Some, for example, refer to the ancestors' original place of settlement or to an associated natural species, as in the case of Ana Mburungu, 'Children, People of the Gewang Palm'. Only one clan in Rindi is named after a ritual function assigned to it. This is Uma Paterangu (*uma*, 'house'; *paterangu*, 'to wind a cloth around the head'), which has the task of placing the head-cloths on the nobles' special funerary attendants (*papanggangu*).

Although lineages do not as a rule change their clan name subsequent to fission or migration, there are a few cases where this has occurred. The clan called Ana Nggela, for example, is said to descend from members of the Ana Mburungu nobility (in fact from a more senior line of the noble clan) who fell into poverty and, contrary to the rules of class, took slave women as wives. The group is therefore no longer formally considered to be of noble rank or a part of Ana

Mburungu, though members of the latter clan still privately acknowledge its derivation and in other ways express their common descent.⁵ The name Ana Nggela is taken from the phrase Haparuna-Ana Nggela, which denotes the ceremonial gongs belonging to the noble clan. In other cases, members of a clan have come to be known only by the name of the domain where they were previously established.⁶ One example of this is the clan Kanatangu, whose original name, Ana Maeri, is still remembered only by one or two older men.

There are three clans in Rindi which share the clan name Ana Mburungu but recognize different founding ancestors (*marapu*). One is of course the noble clan, while the other two are of commoner status. Of these latter clans, one is usually distinguished as Ana Mburungu Kanoru, after the village where its senior house is located, and the other as Ana Mburungu Kalindingu, after the name of its ancestor.⁷ While no one I questioned could suggest how this situation might have come about, it is possibly the result of an ancient fission that occurred long before these groups settled in Rindi. However, it is important to note that, in recent times at least, it has not been the usual practice for a lineage to begin to recognize a distinctly named *marapu* ancestor subsequent to splitting from the main body of a clan or establishing itself in another domain.

Referring to the sense of the word for 'clan' (*kabihu*) as 'corner', Kapita (1976a:13, 263) suggests the term may reflect a former organization in which a village contained four clans, each occupying one corner of the settlement. While the conjecture as it stands cannot be substantiated, the idea that the word refers to some form of quadripartition is not inconsistent with the practice, mentioned in the last chapter, of naming clans in sets of four in ritual speech. Clans whose names are recited together are called *ndekilu kabihu*, 'paired clans', or *ndalaru kabihu*, *juru watu uma*. *Ndalaru* and *juru* both mean 'row' or 'line', while *watu uma* ('house stone') refers to the foundation of a house. The latter phrase also appears as the complementary term of *kabihu* in other expressions. This indicates, then, an identification of a clan with a particular house, which clearly is its ancestral house. The image these phrases suggest is thus one of a number of houses standing in a row, as is the case within a village. Accordingly, the practice of naming four clans together was said to refer to a past or present residential connexion between them.⁸

Two or more of a number of clans whose names are thus mentioned together sometimes also recognize the same clan ancestor, or have

ancestors that were agnates. For this reason, such clans are supposed not to inter-marry, though in some cases the rule is no longer observed. According to a general tradition in eastern Sumba (see Kapita 1976a:14), an agnatic relation of this sort obtains among the eight clans (here listed, as is usual, in pairs) Kahiku—Ana Mburungu, Maritu—Ana Kapu, Karindingu—Mbara Papa, and Mburu Pala—Marada Witu.⁹ The ancestors of these groups were the children of the personage called Umbu Pala—Umbu Lapu, who is thus their common *marapu ukurungu* (see Chapter V), and all of them, I was told, were once established in or near Parai Kakundu, the original village of the noble clan Ana Mburungu, in Kambera. As I remarked in the last chapter, it is evidently because of this connexion that members of the last six named clans in Rindi occupy the position of ‘ceremonial partners’ (*mbapa tunu manahu*) of Ana Mburungu. Since members of Ana Mburungu in Rindi are nobility, while the local members of the other clans are all commoners, however, the former now usually deny that their ancestor was related agnatically to those of the other clans. Moreover, since Umbu Pala—Umbu Lapu is now regarded as the *marapu* of the commoner clan Ana Nggela, which as noted just above formerly belonged to the Ana Mburungu nobility, this personage has similarly been relegated to a position lower than that of Umbu Lutungu, the founding ancestor of the Rindi noble clan. Accordingly, members of the nobility claimed that Umbu Pala—Umbu Lapu was not the father but a brother, in fact a younger brother, of their own ancestor.

In other cases, however, an agnatic relation between the ancestors of two independent clans is still acknowledged in a shared mythological tradition and adherence to the rule prohibiting inter-marriage between their members. One example of this is the clan Luku Walu, whose ancestor was the younger brother of Kàbalu, the ancestor of the clan Lamuru and the earlier inhabitant of the Umalulu district mentioned in the last chapter.¹⁰ The complete title of the Luku Walu ancestor is thus Talu Namba Karata Ende, Kàbalu Mata Urangu; and while the second part of the name strictly speaking designates the ancestor of Lamuru, Luku Walu people in Rindi yet refer to Kàbalu as ‘our ancestor’, and the exploits of this figure serve equally as the clan myth of Luku Walu. Members of Luku Walu are therefore forbidden to eat shark meat, though the myth that accounts for the prohibition refers exclusively to the ancestor of Lamuru.

The importance of the agnatic tie in cases of this sort is further

shown by the fact that when one of two such clans established in the same domain dies out, the other may undertake to refound it by transferring some of its members to the extinct group. The history of the clans Mahora and Katinahu in Rindi provides an illustration of this practice. Some six generations ago, the original Katinahu people, who had become extinct, were replaced by a Mahora man. Since his descendants therefore inherited the lands, property, and ancestral relics of Katinahu, they now call themselves by this clan name and maintain the cult of the clan's founding ancestor. Owing to this arrangement, the two clans are at present regarded as particularly close; thus when needs be, I was told, Katinahu and Mahora men can substitute for one another as wife-givers and wife-takers in respect of affinally related groups. Interestingly, the founding ancestor of Katinahu is now considered the single grandson (SS) of the Mahora ancestor. This relation is of course inconsistent with the original separation of the two clans; but it does reflect the relation between the forbears of the two groups as currently established in Rindi.

Although at present the myths which express such connexions are only partially remembered from place to place, I would conjecture that, if the facts were known, all eastern Sumbanese clans have (or had) a tradition of being agnatically related to one or more other clans. That the pattern seems to be less pronounced in Rindi than elsewhere might be due to the relatively recent formation of the domain as it is presently constituted, as might the fact that Rindi does not have what could be called an 'agnatic core' comprising the most prominent clans in the domain, as is found in Umalulu. Whether one could uncover agnatic connexions linking all eastern Sumbanese clans, on the other hand, seems less likely, though one informant did suggest this might be possible in principle. Furthermore, the apical ancestors of many clans are said to have been related as affines, which thus formally precludes agnation as the most significant mode of connexion in these cases.

2. Segmentation

A list of Rindi descent groups with their current living membership is given in Appendix II. These mostly comprise local clans, i.e., exogamous groups consisting of all the members of a distinctly named clan (or one with a distinct *marapu* ancestor) established in the domain, who recognize a single ancestral house (*uma marapu*). As

I indicated earlier, it is groups of this sort which constitute the highest order of independent corporate descent grouping in eastern Sumba. Ten of the 44 clans whose names appear in Appendix II, however, comprise two or more lineages which, though not distinguished by name and still bound by the rule of clan exogamy, maintain separate ancestral houses and thus function entirely independently of one another. Most of these are lineal segments of the same clan which moved to Rindi from different places and at different times in the past, so that any former genealogical ties between them are no longer remembered. In a few cases, though, separation has resulted from a split within a local clan in Rindi, usually following an unresolved dispute; and there are also instances where a line has to all intents and purposes become corporately detached from the main body of the clan owing to a form of marriage known as *lalei ndàdiku* (see Chapter XVIII). Since in these cases no two independent lineages of the same clan share the same principal settlement (*kotaku*), however, they can be distinguished with the names of the villages in which their ancestral houses are located. For all practical purposes, therefore, it is reasonable to treat them in the same way as local clans; so Appendix II can be said to contain 59 independent descent groups.

As the list reveals, Rindi local clans are on the whole rather small. About 27 per cent have fewer than twenty free members; and if we count groups which despite nominal clan affiliation act as independent corporations, the figure rises to above 40 per cent. In part this reflects the fact that many have been established in the domain for only a few generations; thus these lineages have a correspondingly low genealogical depth. It is consistent with these features that such groups in Rindi display a high degree of corporate unity.

Only two clans in Rindi, the noble clan Ana Mburungu and the commoner clan Mahora, are divided into named lineages. According to the genealogies of both clans, the segmentation occurred after they had established themselves in Rindi. Indeed, named lineages seem to be specific to the clan localized within a single domain throughout eastern Sumba; thus where members of Umalulu clans divided into lineages have migrated to Rindi they have retained only their clan name. Wherever this pattern is found in eastern Sumba, the names of the lineages are taken from those of their respective oldest houses, which are usually all located together in the clan's main village. In Rindi, however, members of a single named lineage normally reside separately in a number of actual houses; and the word for 'house'

(*uma*) is not used by itself as a generic term for named lineages. While such groups are occasionally called *kabihu*, a somewhat more specific designation is *kaloka*, 'row, line, section, division'.¹¹ But *kaloka* can refer to any level of segmentation below the local clan, whether or not the groups so distinguished are formally named; and the minimal definition of the term in this general sense would appear to be a line consisting of two or three generations of adult males. With regard to its lack of specificity, therefore, *kaloka* could just as well be translated simply as 'group'. Indeed, another word for 'group', *bànjaru*, is sometimes used interchangeably with it in this context.

Since the clan Mahora comprises only two named sections, segmentation into named lineages in Rindi is best described with specific reference to the Ana Mburungu nobility. In this case there are six lineages,¹² all of which trace descent to a single (apparently historical) ancestor. The names of three of these groups, and hence their oldest houses, indicate the special functions assigned to them. Uma Penji, 'Flag House', refers to the symbol of office given by the Dutch to the leader of this group, who as noted was appointed raja of the Rindi district; while Uma Andungu, 'Skull Post House', reflects the association of this lineage and its house with the post on which enemy skulls were placed. Similarly, the term *wara*, 'to cry out', as in Uma Wara, refers to a sort of diatribe uttered in the field of battle denouncing the supposed misdeeds of an enemy in order to dispirit him. It was in this house, I was told, that plans were discussed and preparations made before going to war. (As noted, the lineage Uma Wara also has special duties in rites concerning the downstream end of the chief village.) The names Uma Jangga, 'Tall House' and Uma Kudu, 'Small House', on the other hand, are purely conventional designations. Though they accurately describe the relative proportions of the physical buildings, the former is not in fact the tallest. Uma Kopi, 'Coffee House', is said to be so named because the founder of this house introduced the practice of drinking coffee to Rindi. Of these six names, only Uma Kopi and Uma Penji are not, so far as I know, encountered in other parts of eastern Sumba.¹³

Two of the named segments of Ana Mburungu — Uma Jangga and Uma Penji — keep in their respective lineage houses separate metal relics (in this instance designated as *kawàdaku*), which are used as media in rites that concern each group exclusively. The houses of Uma Andungu and Uma Wara, on the other hand, are said to contain *marapu* relics (*tanggu marapu*, see Chapter V); and these, by contrast,

serve as special media in ceremonies that involve the entire clan. Only the latter two buildings, therefore, are said 'to have *marapu*', and they are thus sometimes spoken of as 'ancestral houses' (*uma marapu*), though in its more specific and usual sense this term denotes only the clan's common ancestral house, Uma Bokulu. Uma Jangga and Uma Penji, by contrast, are classed as 'cool houses' (*uma maringu*, see Chapter I). Among other clans, only the group's oldest house contains *tangu marapu*. Therefore, with regard to Rindi, Wielenga's (1909c:337) statement that each clan member keeps separate relics in his own house is generally incorrect.

As noted in the last chapter, the lineages Uma Penji and Uma Jangga represent the earliest segmentation of the noble clan. The order of derivation of the others from these two is illustrated in Fig. 7 (see

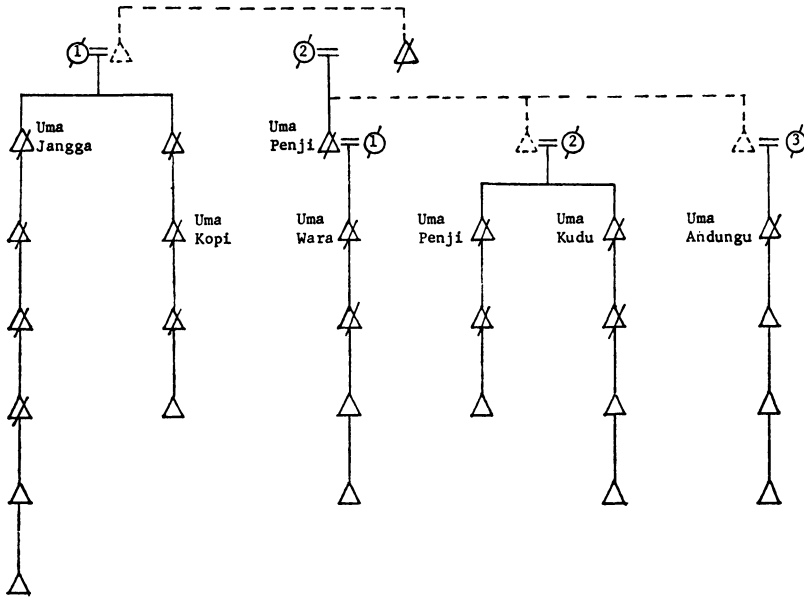

FIG. 7. Segmentation of the Noble Clan Ana Mburungu

also Appendix I), which shows a simplified genealogy traced to currently living males (the numbers indicate the marriage order of wives; elder sons are to the left). The six lineages are also spoken of as forming two groupings of higher and lower noble rank respectively, the former comprising Uma Penji, Uma Kudu, and Uma Andungu, and the latter Uma Jangga, Uma Kopi, and Uma Wara. Although Uma Wara derives from Uma Penji, its ancestor was born of a woman

of lower rank (by some accounts a commoner); so while in terms of descent it belongs with the first group, as regards class standing it is included with the second. Since by the first criterion Uma Wara is moreover actually senior to the present members of the three higher ranking lineages, it is interesting, recalling the division of spiritual and temporal authority between elder and younger, that this group is assigned special ceremonial duties.¹⁴ The founders of Uma Kudu and Uma Andungu were also sons of the Uma Penji ancestor, but by wives from the Umalulu noble clan Palai Malamba who were full sisters. Uma Kopi derives from a son of a younger brother of the Uma Jangga ancestor.

The division of the Rindi noble clan into named lineages thus expresses differences of birth order and noble rank among their respective forbears; and in four instances of segmentation it seems particularly to reflect the general (though not consistent) practice in polygynous marriages of accommodating co-wives in different buildings. (As rank is related to alliance, the fact that the lineages, in varying degrees, are connected with different affinal groups is evidently also entailed in this pattern of segmentation; but this topic is better left until the corporate features of descent groups in general have been described.) It seems, however, that internal distinctions of these sorts are not sufficient in themselves to produce formal segmentation of a clan, for such differences also exist (albeit to a lesser degree in the case of rank) within other (commoner) clans of equivalent genealogical depth which are not so divided. In the case of Ana Mburungu, therefore, a more relevant feature of the lineages might be that by virtue of their many slaves, each is able to maintain itself independently in terms of subsistence economy. In fact, with regard to the number of persons corporately obligated to the group, each of these lineages is larger than many individual commoner clans (see Appendices II and III). Perhaps an even more significant factor, though, is the association, in four out of six cases, of the various noble houses (the actual buildings as well as the lineages after which they are named) with the special secular and ceremonial functions described above, since these are exclusive to the noble clan.

The division of the large commoner clan Mahora into two named segments, on the other hand, appears to involve little more than a distinction of senior and junior lines. The senior lineage, being the one more closely associated with the clan's ancestral house, is thus called Uma Bokulu, 'Big House',¹⁵ while the junior lineage is named

Uma Pada Njara, which in the longer form *uma pada njara, pada karimbua*, 'house of the horse and buffalo pasture(s)', is also a general expression for a purely residential or 'cool' house.¹⁶ So far as I know Uma Pada Njara has never maintained any special ritual or secular functions within the clan, and formally speaking the two groups do not differ in rank. Since the junior lineage is now wealthier and much larger, and maintains alliances with somewhat more prestigious affines than does the senior one, however, the division is generally in accord with the distinctions between elder and younger groups described in the previous chapter. As to why this sort of formal segmentation is not found among other large commoner clans in Rindi, the most relevant factors seem to be that Mahora is somewhat longer established in the domain and has a greater genealogical depth — the two lineages being separated by seven generations — than other groups.

3. Corporations

In view of Leach's (1961:56) contention that corporate groups which arrange marriages are almost always local groups, it is useful to begin this section by discussing residential organization. As I noted earlier, the houses and adjoining fields of a (local) clan are usually distributed among a number of settlements (*kotaku*), often several kilometres apart. With named lineages, too, most members live permanently in villages other than the one containing their principal (lineage) house, which, being mainly the responsibility of the most senior family, is usually occupied continuously by that group alone. The house then serves as a focus for ritual and secular activities that concern all members of the lineage but not the clan as a whole. Thus named lineages are residentially dispersed in the same way as are local clans, and their internal organization largely reflects that of the larger clan of which they form parts.

While some forms of marriage require a period of uxorilocal residence (see Chapter XVIII), most couples in Rindi were in fact virilocally resident, and in the long run patrilocality is the norm. Sometimes, though, uxorilocal marriage can lead to members of a clan becoming permanently established in the village or domain of a wife-giver. Single-family houses do occur, especially in minor or subsidiary settlements (*kotaku kudu*; see Chapter II), but married couples are not normally expected to found houses of their own. A house group thus often consists of two or more brothers and their families and

perhaps their elderly parents, and sometimes a building is inhabited by an even wider agnatic group. Usually the occupants of a single house are more closely related to one another than to agnates living in other houses. However, when a house becomes too full, junior members, instead of building a new house in the same village or founding a new settlement, will sometimes move to another village already inhabited by more distant agnates; thus this pattern is not always replicated at the level of the village, and, indeed, one sometimes finds fathers and sons residing in different villages.¹⁷ It should also be noted that residence, particularly in subsidiary villages of a clan, is often quite fluid, and (discounting temporary uxorilocal residence) I found cases where a man had dwelt in two or three different villages of his clan during his lifetime. Residential differentiation at this level, then, does not always correspond to lineal segmentation.

While members are usually divided among several villages, therefore, the Rindi prefer to stress the unitary nature of clan membership. The most tangible expression of this unity is of course the clan's ancestral house; so it is in this regard that the common statement that all clan members live in this house (which is patently contradicted by actual residence patterns) is to be understood. Although it is divided into named lineages, these remarks largely apply also to the noble clan in Rindi, as this clan too recognizes a single ancestral house (the one called Uma Bokulu). It follows, then, that the founding of a separate ancestral house, normally subsequent to settlement in another domain, signals the fission of the clan as a corporate group.¹⁸ Thus, for the most part, it is evidently at the level of the domain rather than the village that patrilineal descent groups in Rindi can be considered corporate 'local descent groups' in the sense in which Leach (1961:56) uses this term.¹⁹

In view of the religious significance of the ancestral house, it is appropriate that those undertakings which most clearly manifest the corporate nature of the clan are of a ceremonial kind. This I have already illustrated in the case of the funeral, perhaps the most frequent and public occasion for concerted action by fellow clansmen, when all members must contribute to the provision of animals for slaughter, cloths in which to enshroud the corpse, and goods to be exchanged for funerary prestations brought by affines; and all affines of the clan should be invited to attend. While the last requirement is often relaxed and insisted upon only when the deceased is a senior member

of the clan, everyone (excepting slaves) is brought to the clan's ancestral house for burial and so buried in the clan's principal village (see Chapter II).

For the most part, these arrangements are also observed by clans that comprise named lineages. Thus the corpse of an Ana Mburungu nobleman should be prepared for burial, and the subsequent mortuary rites should take place, in the clan's ancestral house (Uma Bokulu); and traditionally all the betel containers of the noble dead were kept in this building. Yet, contrary to these requirements, the three noble funerals I attended in Rindi were each centred in the individual lineage house of the deceased, and, though in every case all the other lineages contributed cloths in which to wrap the corpse, only affines of the dead person's own lineage were invited. This abbreviation of traditional practice, however, was attributed to the fact that Uma Bokulu is at present in a state of disrepair, and I was assured that the final, collective obsequies (*pahili mbola*) could not take place in any house but this. Since the Rindi nobility further insist that the most elaborate form of the noble funeral (which involves playing the gongs kept in this building) can only be held in Uma Bokulu, it seems they would also postpone the burial of a high ranking nobleman until the house was renovated. But as I noted in Chapter IX, one lineage of Ana Mburungu, albeit much to the disapproval of the rest of the clan, performed the *pahili mbola* separately while I was in Rindi, and the (relatively impoverished) funeral of a sister of the last government raja, which took place in the same year, was centred in the house of her own (natal) lineage, Uma Penji. There is some reason to suppose, then, that the lineages of this clan are becoming corporately more independent of one another than they were in the past. Indeed, the fact that the repair of the Uma Bokulu has now been left for so long could be taken as a symptom of this.

In contrast to major ritual undertakings like the funeral, numerous minor ceremonies, such as many agricultural and life cycle rites that require little expenditure, need concern only a limited circle of agnates and are usually held in the principal's own house (or lineage house, if the clan is so partitioned). For some ceremonies (e.g., *hàngguru*, see Chapter VIII), however, although they need not be held in the clan's ancestral house, it is minimally required to invite, besides agnates living in the same village, the clan headman and other senior members of the clan. At any rate, this is the case with formally unsegmented clans in Rindi. As regards the noble clan, by contrast, when Uma Penji

holds a rite, representatives from the other named lineages are normally invited to partake in the meal, but it is not so strictly required that these other lineages reciprocate when they hold rites of their own. Apparently this is because Uma Penji, the secular leader, is the highest ranking of the noble lineages; thus matters which specifically concern this group are considered also to affect the noble clan in general. Among the nobility therefore, in some contexts it is apparently members of the clan highest in class standing rather than those who are senior in terms of lineal descent that represent the clan as a whole. (Another instance of this is given just below.)

In accordance with the general principle that secular matters involve sectional interests to a greater degree than do ceremonial ones, as regards subsistence and property relations the corporate character of Rindi descent groups is rather less pronounced than in ritual activities. Rights to the use and produce of fields and the ownership of small livestock and useful trees are held by individual adults, and each adult man is entitled and expected to work a parcel of land to satisfy the subsistence needs of his own family. Individually held rights of this sort, all of which are patrilineally inherited in Rindi, however, are always potentially subordinate to the interests of larger agnatic groupings and ultimately to the clan as a whole; and the use and distribution of lands among its members can become a matter for the entire clan to decide. Thus a man cannot independently alienate land to persons of another clan. Clan mates are also expected to assist one another materially when needs require and to provide mutual help in agricultural tasks. But for the most part it is usually not necessary to turn for assistance other than to agnates resident in the same house or village. Subsistence groups, therefore, tend to be considerably smaller than the local clan as a whole.

Co-operation in subsistence matters within formally segmented clans normally does not extend beyond the named lineage, though in the case of the Rindi noble clan the degree to which its component segments are recognized as independent of one another in this regard varies according to their degree of genealogical separation (see Fig. 7). Thus, while Uma Jangga, for example, is economically separate from Uma Penji, the more closely related lineages Uma Kudu and Uma Andungu are in some ways represented as dependents of the ruling lineage.²⁰ Wet rice lands owned by the nobility are spoken of as belonging to individual lineages rather than to the clan as a whole. But single paddy fields are in fact exploited exclusively by individual

adult noblemen, who are sometimes referred to with the names of these fields in everyday speech. Here it should be recalled that the bulk of work in fields owned by the nobles is carried out by slaves, who belong to the individual lineages and through residence are more specifically attached to particular noble families.

The only case of agricultural land that could arguably be described as the common or corporate property of a clan is the *lâta marapu*, 'ancestral field', the oldest paddy field consecrated to the clan ancestor, the produce of which is used in the clan's first fruits (*ngangu uhu*) ceremony. To all intents and purposes, however, such land is held and controlled by the clan's most senior members, or in the case of the noble clan by the highest ranking, ruling lineage, Uma Penji. Although among the nobility the *lâta marapu* is thus apparently owned by the secular leader, the fact that it is nevertheless identified with the clan as a whole is significant insofar as it concerns the clan's religious life rather than subsistence as such.

Goods used in affinal exchange — metal valuables, large livestock, textiles, and so on (see Chapter XVII) — are also held by individual adult men, or by the heads of larger family groupings (an elderly father or elder brother) before an inheritance is divided among a dead man's sons. Thus this sort of disposable wealth, too, is not strictly speaking owned corporately by the clan (or named lineage).²¹ As with regard to land, however, by virtue of its internal authority structure the clan as a whole can restrict the ways in which such goods are used. Thus, while the principal portion of a bridewealth (the *pingi wili* or *aya wili*, see Chapter XVII), which is due to the bride's father, is the responsibility of the father of the groom, and it is preferred that he himself pay it in full, the parents of a prospective spouse must nevertheless inform and secure the agreement of other clan members, and that of the clan headman in particular, before a marriage is contracted; and failure to do so can result in a serious dispute within the clan.²² Especially when the total bridewealth is high, moreover, the bulk of the gift will comprise what is called the 'junior bridewealth' (*eri wili*). This consists of single increments contributed by the groom's father's brothers and more distant agnates, which are then reciprocated with counter-prestation goods provided by persons similarly related to the bride's parents. Therefore, since any clan member can be asked to participate in this, depending on the scale of prestations the wife-giver requires, the entire clan may become involved in the exchange.

Since the clan thus exercises corporate control over the exchange of goods held by its members that are used as affinal prestations, and hence over their marriages, it is important to determine in what sense it might be considered an alliance group. This question is better answered separately for clans such as Ana Mburungu and Mahora which comprise named lineages and those which do not. In the former case, while the consensus of the entire clan should be secured before a marriage may proceed, and all lineages should contribute to the marriage payments and attend the major negotiations, it is permitted for one named lineage of the clan to take wives from a group to which another gives wives. Thus in this instance it is not the clan as a whole but its segments which are bound by the rule enjoining a unilateral transfer of women in marriage.²³ In this regard, it might be supposed that a pattern of differential alliances may have contributed to the development of named lineages in such cases.²⁴ Among neither of the formally segmented clans in Rindi, however, is this marriage pattern particularly pronounced,²⁵ and according to their genealogies all unions that reversed the direction in which women were transferred (at the level of the clan) appear to have occurred after the lineages had been founded. Moreover, I found no evidence of the practice whereby alliance ties are systematically reversed in order to signal segmentation within clans, such as Clamagirand (1975: 45) reports among the Ema of Central Timor. It seems, therefore, that while the presence of named lineages facilitates the contracting of differential alliances by clan segments, this practice is not a precondition of formal segmentation of this sort. Nor is formal segmentation the necessary result of incorrect marriages.

Among unsegmented clans, by contrast, the rule prescribing unilateral marriage does formally apply to the local clan as a whole; and while marriages that constitute direct exchange between such groups do occasionally occur, their incidence is not so high as to suggest that in general smaller, unnamed lineal groups systematically function as independent units of alliance (see Chapter XIX). As I shall later elaborate, though, participants sometimes rationalized marriages of this sort on the grounds that the individuals belonging to one or both of the clans were sufficiently distantly related as agnates that the unions need not be counted as incorrect, thus in other words by reference to the segmentary principle inherent in their lineal organization. But such unions, it should be stressed, do not regularly result in a formal separation of the lineal groups concerned.

As is especially clear from the case of clans that comprise named lineages, therefore, while the entire clan has a collective interest in, and exercises control over, the marriages of its members, it is not hereby entailed that all unions they contract be governed by the same alliance connexions. Thus while in one sense the local clan, as the group which is (potentially) corporately involved in the exchange of marriage prestations, might be regarded as an alliance group, if this term is taken to refer to a group that must maintain unilaterality in the transfer of women in marriage, in some cases it clearly is not. The alliance group can then be smaller than the corporate local descent group (the local clan), which in turn is nearly always smaller than the unit of exogamy, i.e., the clan spread over several domains. I shall take up this matter again in Chapter XIX.

4. Corporate Aspects of the Village

As a final note, it is appropriate to mention another framework of concerted action in Rindi, namely the relation between lineal groups living in the same village, or 'village mates' (*angu kotakungu*). Since over forty per cent of Rindi villages include persons of different clans, the proportion being higher among those that contain ancestral houses (see Chapter II), it is evident that a village often does not constitute a single level of patrilineal descent grouping. Thus village mates may be related to one another as agnates, affines, or in neither way. Yet as I have previously shown, on certain occasions a village (or a cluster of two or three villages) is expected to act as a body. These include funerals, when co-resident clans mutually provide one another with material assistance, and marriage involving groups outside the village, in which context, if the total bridewealth is high, fellow villagers who are not agnates may also contract to participate in the exchange of prestations.²⁶ Indeed, whenever a clan must receive guests (i.e., affines) all inhabitants of the village are expected, if requested, to assist in providing food and hospitality. Village mates also regularly help one another in major agricultural tasks, in return for which they are fed by the beneficiary. As I mentioned in Chapter X, at noble marriages and at other times when the nobility receive affines as guests, help may be solicited from all clans in Rindi; so on these occasions the entire domain, as well, can take on the character of a single corporate body. To appreciate what these practices entail, it is relevant that those undertakings which most clearly manifest concerted

action by the village or domain involve the reception of groups from the outside.²⁷ The pattern thus evidently derives from an opposition defined in terms of locality, and so is similar in all essentials to that which Cunningham (1966:19-20) describes for the Atoni. In Rindi, however, I never heard anything comparable to the Atoni notion that a village is in this respect 'one house'. Such an idea could appropriately be applied there only to a patrilineal clan or, as I shall describe in the next chapter, to two groups related as affines.

CHAPTER XIII

THE ALLIANCE RELATION

The Rindi social order is governed by a system of asymmetric prescriptive alliance. Wives and certain classes of goods are unilaterally transferred between groups, and marriage is enjoined between persons of the category *balu* (MBD, etc., m.s.; FZS, etc., w.s.). For the moment, however, I am not concerned with rules of marriage, which are discussed in Chapter XV, but with the component ideas and institutions of the alliance relation.

1. *Categories*

Wife-givers and wife-takers in Rindi are distinguished as *yera* and *anakawini* or *layia*. Both agnates and groups not related affinally to one's own are designated as *angu paluhu*. While the terms can be applied to entire lineal groups, *yera*, *layia*, and *angu paluhu* are also the category terms which, for male ego, include respectively MBS, FZS, and B (also WZH and ZHBWB). They thus coincide with the three principal lines found in the relationship terminology. The three categories articulate two component relations: *payera-palayiangu*, the relation of wife-giver and wife-taker, and *paangu paluhungu*, the relation of 'brothers'. The former, then, is what is normally called alliance, while the latter formally excludes the possibility of marital connexion.

Wife-givers and wife-takers are also classed together as *kalembi*, which may therefore be translated as 'affines'. The word further denotes any sort of tailored garment that covers the upper part of the body. The Rindi claim these two senses of the term are related, and they compare the manner in which a shirt fits tightly around the torso with the way affines surround the natal group.¹ A similar idea is suggested by the expression *tana la nua, watu la lihi*, 'land that adjoins, stones by the side', which denotes both sorts of affines in ritual speech.

Specifically, it indicates the close and supportive nature of the affinal tie and the notion, which I shall later elaborate, that affines form in a sense an extension to one's own group.

Besides one's own affines, *kalembi* is further applied to parties indirectly related through marriage, such as the wife-givers of wife-givers and the wife-takers of wife-takers, and it is sometimes used also for non-agnates otherwise classified as *angu paluhu*.² Thus, in this context at least, its opposite term is not *angu paluhu* but *angu kabihu*, 'clan mates'. With regard to immediate wife-givers and wife-takers, the Rindi distinguish affines of long standing from those with whom marriages have only recently been contracted as *kalembi ndai* and *bidi kalembi*, 'old' and 'new' affines. The former were defined for me as groups which have given or taken wives for at least three consecutive generations, but in practice they sometimes employ the term more loosely than this. Similarly, I was told that if marriages are not contracted for three or more generations, an alliance can be considered null, and the direction in which women are transferred can then be reversed. If a woman is taken from a current wife-taker and the union is to be accepted, on the other hand, a procedure involving a cooling ceremony must be performed in order to 'return the salt water, to turn around the fresh water' (*pambelingu wai mbàru, panjà-ngangu wai kàba*), i.e., formally to reverse the relation. But ordinarily this seems to be feasible only when the parties have just recently become affines, thus when only one or a few women have been taken from the former wife-giver.

One of several expressions used to describe 'old affines' is *pawatu mitingu*, 'like black (i.e., hard, volcanic) stone', referring to the hardness or firmness of an alliance that has endured. A recently initiated affinal relation, by contrast, is said to be 'like a village square of soft chalkstone, like a fence of *padamu* plants, like an adjoining area of black earth, like a bank of soft red soil' (*patalora watu pudangu, pakanjangaru padamungu, panua tana mitingu, palihi tana udangu*). Recent affines are also called simply 'chalkstone affines' (*kalembi watu puda*). Black and red soil are characteristically soft and unfirm, as is chalkstone by comparison with black stone. The significance of the *padamu*, a plant from which resin to light torches is obtained, is its soft and flexible stem.

The Rindi say that wives should be given to and taken from established affines, and that once initiated an alliance should be continued. Thus the main consideration when contracting a marriage

should be the consequences of the union for existing alliance connexions. These values find expression in the maxim 'let not the line of cloths snap, let not the pole on which pigs are carried break' (*ambu na-mbota na londa kamba, àmbu na-mbata na malinggi wei*), which refers to the tie that binds allied groups. Since cloths and pigs are things given to the wife-taker by the wife-giver, and both symbolize women, the phrases thus represent the alliance tie in terms of things emanating from the wife-giver. As regards maintaining alliances, however, the Rindi make some distinction between old and new affines; and though I found no hard and fast rule in this respect they seem generally less concerned about perpetuating recent alliances than longer established ones. This accords, then, with their characterization of the former as soft and unfirm, or in other words, yet to be consolidated. Despite the preference for marriage with established affines, moreover, provided that old alliances are maintained they see nothing wrong in initiating new ones; and they can conceive of legitimate circumstances in which a long established alliance might be discontinued, for example, if a wife-giver begins to take women from groups of markedly lower rank than previously.

2. *Wife-givers and Wife-takers*

As is common elsewhere in eastern Indonesia,³ the Rindi distinguish wife-givers and wife-takers as masculine (*mini*) and feminine (*kawini*) affines. Similarly, the complementary prestations exchanged whenever the two meet formally are subsumed under two major classes of valuables: 'masculine goods' (*banda mini*), consisting of horses and metal ornaments given by the wife-taker, and 'feminine goods' (*banda kawini*), which comprise textiles, beadwork, and ivory given in reciprocation by the wife-giver (see further Chapter XVII). The symbolically masculine party therefore receives masculine goods, and the feminine party feminine goods.

Since the traditional practice was to slaughter a dog for a wife-giver and a pig for a wife-taker, these animals, too, are classifiable as masculine and feminine respectively.⁴ Because dog meat has fallen into disfavour in eastern Sumba, however, a buffalo or a pig is now slaughtered instead. But as regards pigs, the distinction of gender in respect of the two sorts of affines still finds expression in the rule that only a boar may be slaughtered for a wife-giver. If by oversight a sow were substituted, the recipient would be offended and could demand

that a metal pendant and chain be given as compensation, in order to 'close the (animal's) anus (i.e., vagina)' (*pabita wàngu kalilina*).

The symbolic femininity of the wife-taker is further suggested by the designation *anakawini*, which in Rindi is somewhat more common than *layia* as a reference to wife-taking affines. The term is a compound of *ana*, 'child, person', and *kawini*, 'woman, female, feminine', and as a reference to wife-takers is perhaps best glossed as 'children of females'.⁵ The meaning of 'wife-taker' of course presupposes a system of asymmetric alliance, whereby men whose female ascendants were born to one's own group have a recognized claim to continue taking wives.⁶ However, in accordance with the symbolic classification of wife-takers as feminine, *anakawini* might just as correctly be translated as 'feminine children, people'. A number of expressions from ritual speech refer to wife-takers as chickens and pigs.⁷ This, too, is intelligible only with reference to the symbolic femininity of wife-taking affines, since, by contrast to horses and buffalo, or 'goods on the plain' (*banda la maràda*), these animals are associated with women and with the house (see Chapter I). The names of the two classes of domesticated animals are therefore further employed to refer to male and female children, though since the care of chickens and pigs, like that of infants, is assigned to women, the names of these animals alone are sometimes used to indicate children of both sexes. It is thus said of a barren woman that 'the pigs and chickens do not multiply, prosper for (by, with) her' (*nda na — woruanya wei manu*).

The distinction of gender with regard to wife-givers and wife-takers is also consistent with the recognized superiority of the former. This is expressed in several other ways. Thus in transactions between affines, a wife-giver is addressed with the phrases 'the lord my father, the lady my mother' (*na umbu amanggu, na ràmbu inanggu*), which combine the parent terms (*ama, ina*) with the honorifics applied to persons of high rank (*umbu, ràmbu*).⁸ The wife-taker, on the other hand, is addressed as *na ananggu, na homunggu*, both of which terms can be translated as 'my child'.⁹ *Homu*, which appears with this sense only in this formal idiom, ordinarily means 'to suck, take milk', and can therefore be glossed as 'suckling'.¹⁰ The phrases thus evoke the image of the wife-giver, like a (female) parent, providing the wife-taker with vital fluids, which being in this instance clearly feminine can be equated with the women given in marriage. Significantly, Kapita (1976a:84) interprets the phrases to mean 'those who imbibe blessing and favour from their parents'.

Other expressions for wife-takers which suggest that alliance is conceived to be like the relation of parent and child include: 'child inside the house, in the centre of the floor, child in the space between the hearth stones, in the heart of the hearth' (*ana la kuru uma, padua kaheli, ana la kanjonga tuluru, la eti ai*); *ana nda ku-mili maunya, homu nda ku-hibi halanya*, an expression I find difficult to translate, but which might be glossed as 'child whom I do not let float away, whom I do not split (from?) wrongly'; and 'child in the womb (or sling) of the skirt, the fold of the man's cloth' (*ana la kalunggu lai, la habibi hinggi*). The first pair of phrases describes the wife-taker as someone securely placed inside the (wife-giver's) house; and as I shall later show, 'house' can here be understood as a reference to the alliance itself. By contrast, the third expression refers to textiles of the sort given in affinal exchange by the wife-giver, which in this idiom appear to symbolize the protective nature of alliance for the wife-taker. Indeed, Kapita (1976a:84) interprets the phrases to mean 'child who is always under the care and protection of its parents'. The use of parent terms to denote wife-giving affines is found also among the Belu (Vroklage 1952:I:225), in Kédang and East Flores (Barnes 1974:250), and in Manggarai (Verheijen 1951:26); and as illustrated previously, in Rindi, as elsewhere, this is a common way of referring to various parties that are in a position of authority or in some other way superior. Although as a reference to wife-givers and wife-takers the parent and child terms in Rindi are encountered only in the lexicon of parallel speech, the usage can also be seen as an equivalent expression of the terminological feature whereby the two sorts of affines are classified respectively with ascending and descending generations, as occurs in some other systems of asymmetric alliance.

The relation of wife-giver and wife-taker is further represented in terms of the distinction of *pingi*, 'trunk', and *kapuka*, 'tip', introduced in Chapter I.¹¹ In this context the additional senses of *pingi* as 'source, origin' and 'principal (part)', and of *kapuka* as 'derivative', are especially relevant. Thus a wife-giver is described by a wife-taker as 'our trunk of wood, our source of water' (*pinginda la ai, matanda la wai*); 'the trunk (tree) from which wood is chopped (or gathered), the source (spring) from which water is drawn' (*pingi ai papunggu* [or *paohu*], *mata wai pataku*); and 'enclosure of cactus, source of the great mares' (*kuru ai kalàla, kapingi bai njara*) (*kapingi* is a variant of *pingi*). Sometimes the last pair of phrases is used to specify the wife-giver of the wife-giver,¹² which makes sense when it is considered

that if the wife-giver is regarded as a source, then, since the distinction of *pingi* and *kapuka* is a relative one, so too must be this group's wife-giver. The phrase 'enclosure of cactus', on the other hand, evidently refers to something that affords protection. The Rindi also designate wife-givers with the expression 'pasture of fine horses, spring of precious metal' (*pada njara hàmu, mata wai àmahu*), which seems to specify them as providers of prosperity and well-being, a common idea in Indonesia (see van Ossenbruggen 1935:11). But since wife-givers do not actually provide wealth of the sort to which the phrases refer (indeed it is the wife-taker who provides these things to the wife-giver), it would appear to be well-being in a more general sense that is alluded to here. Kapita (1976a:84) thus glosses the expression as 'well, source of magnificence and greatness'.

In two of the above expressions, *pingi* is conjoined with the partially synonymous word *mata*, which, as in other Indonesian languages, has among its senses 'eye', 'face', 'front', 'source', 'beginning', 'nucleus', and 'focus'.¹³ Although space does not permit an adequate examination of the range of this term,¹⁴ it is worth noting that with certain plants *mata* refers to the end of the fruit to which the stalk (*kaleki*) is attached and from where the new shoot, and hence eventually the *pingi* (specifically the bottommost part of the stem), will emerge. In this instance, then, the two words are related in a way similar to the cognate *matan* and its complement, *puen*, in Kédang (see Barnes 1974:231).

Wood and water as they appear in phrases designating wife-givers in Rindi evidently refer to the women these groups provide. This is also made clear by an expression of the precept that one should not take wives other than from established wife-givers: 'we do not search again for wood in another forest, or seek water from another source, spring' (*nda ta-hili himbu ai hau omangu, nda ta-hili himbu wai hau mata*). In this context, however, wood and water can further be said to represent all things essential to life, an idea supported by Kapita's (1976a:84) gloss of the phrase *pingi ai papunggu*, 'trunk from which (I) chop wood', as 'source of all blessing and well-being'; and even more directly by another eastern Sumbanese expression for wife-givers that this author records (1976b:119), 'source, tree of life, spring of animation' (*pingi ai luri, mata wai miripu*). These phrases suggest, moreover, that wife-givers are regarded not only as a continuous source of women but also, in a sense, as the source of the wife-takers themselves. The term *polangia* (or *pulangia*), which denotes the MB

and other closely related men in the category *tuya*, is relevant in this respect. The Rindi interpret *polangia* as a combination of *pola*, 'stem, trunk, source', a word largely synonymous with *pingi*,¹⁵ and *ngia*, 'place, party'. It might thus be translated 'trunk of the place', which, according to the native interpretation, is to be understood as 'my (one's) place of derivation'.¹⁶ In respect of its popular etymology, therefore, *polangia* may be compared with Rotinese *toö huk*, 'stem mother's brother, mother's brother of origin' (Fox 1971b:222) and the Kédang *epu puen*, 'trunk *epu* (MB, etc.)' (Barnes 1974:247). The representation of the mother's brother's group as the source or origin of the sister's sons further accords with the eastern Sumbanese idiom whereby a group is said 'to derive from' (*welingu*) an original or principal wife-giving clan (a statement I first took to refer to patri-lineal descent). Perhaps it is in this light, then, that the expression 'house of roasting coconut and scented water, house of the ridge pole and the surface of the plain' (*uma tunu kokuru wai karanu, uma toku ndidu pinu maràda*), which refers to the wife-giver's house, is to be understood; for I was told that these phrases describe the building as a place of birth.¹⁷ As I shall later show, it seems significant as well that the materials mentioned in the first phrase are also ones used in curing illness. It should be pointed out, however, that it is not the usual practice in Rindi for a woman to give birth in her natal home.

The contrast of *pingi* and *kapuka* as applied to affines is of course consistent with the fact that the alliance relation is oriented in a single, irreversible direction. As noted with regard to the house, this distinction is the basis of the rule *palua kawanangu*, 'to move to the right', i.e., from *pingi* to *kapuka*, an order that is often expressed in an anti-clockwise sequence or progression. As this rule is employed to define correct order in a variety of contexts in Rindi, it is not surprising that the prescribed unilateral transfer of wives was also cited as an instance of it.¹⁸ A marriage that reverses this direction is thus described as *panjàngangu*, 'turned around', 'placed upside down, back to front', as would also be, for example, a house post placed with the *kapuka* end in the ground (see Chapter I). In both instances, moreover, observing the correct order is considered essential to human well-being; and as I remarked in the latter case, the incorrect placement of a building component can cause illness and death within a house. Similarly, the Rindi say that marriage with a woman of the prescribed category, especially a close relative from one's own mother's

natal group, confers special benefits: she makes the best sort of spouse; will properly perform her duties as wife and mother; and she will not commit adultery or otherwise cause trouble for her husband. In addition, the union will be fertile and productive. Irregular marriages, on the other hand, are thought likely to be unstable and barren. Marriage which conforms to the rule of asymmetric alliance, therefore, is seen as a natural union which accords with a wider order of relations defined by reference to the proper articulation of *pingi* and *kapuka*.¹⁹

3. Alliance and Descent

Rindi representations of alliance and descent indicate that the two sorts of relations are conceived in similar ways. First, the relation of patrilineal ascendants and descendants, too, is spoken of in terms of the contrast of *pingi* and *kapuka*; for, like a wife-giver, an apical male ancestor is described as the *pingi* of his lineage, and agnatically related lines are sometimes compared to the branches of a tree.²⁰ In this regard the relevant common attribute of the two sorts of relations is evidently that both patrilineal ancestors and wife-givers are sources of life, though as I mentioned earlier they can be distinguished as the ultimate origin and perpetual source of life-giving qualities respectively.²¹ These two applications of *pingi* thus provide another instance of the pattern illustrated previously, whereby otherwise opposed entities are represented as sources of different and complementary kinds.

Secondly, as the notion that wife-takers 'derive from' wife-givers might suggest, the Rindi describe affines as 'agreeing in flesh, connected by blood' (*patuba tolungu, pakei wai riangu*); and they cite this blood tie as the reason a man should marry with established wife-givers. Yet agnates, as well, are said to share a connexion of blood (*nua wai ria* or *kei wai ria*); and, somewhat paradoxically, in this case they cite the blood tie as the reason women in the category *anawini* — Z, FBD, MZD, FZD, etc. — should *not* be married. Although no one I questioned was able to reconcile these two ideas, a solution can be found in two features of the system. First, among affines blood is transferred directly through women while agnation entails blood passed through men; and, secondly, in both instances the transfer of blood, which emanates from a *pingi*, must be unilateral. The latter consideration would account for the prohibition of FZD.

With regard to marriage between MZC, on the other hand, it could be said that because they share the same wife-giver, there is no transfer of feminine blood at all. Expressed in the idiom of *pingi* and *kapuka*, therefore, the relevant contrast in this case is that while affines are opposed in these terms, the children of sisters are *kapuka* who share the same *pingi*.²² In fact, this characterization could be applied to agnates as well, insofar as persons so related share the wife-giving affines of their common male ancestor; so it might be said that all relations that involve a connexion of blood imply blood derived ultimately from women. That blood is not however always immediately provided by women is consistent with the fact that the Rindi do not distinguish physical attributes a child derives exclusively from its mother or father.

At this point we might consider more closely the category *angu paluhu*, which includes among its genealogical denotata B, FBS, MZS, WZH, and ZHBWB, and translates as 'companions in emergence' (*luhu* is 'to go, come out'). The Rindi further explained this to mean 'persons who have emerged from the same womb', which thus agrees with Onvlee's gloss (cited in Fischer 1957:4), 'originating from the same womb'.²³ The underlying idea, therefore, is a conceptual equivalence founded on derivation from the same category of women and hence from the same wife-givers. This does not necessarily entail, of course, that parties so related take women from exactly the same groups. Rather, what is implied is a parallelism of alliance connexions, as pertains, for example, to men reciprocally related as ZHBWB. In its widest sense, then, *angu paluhu* might be glossed as 'co-affines'.

Since it is evidently possible, therefore, to define the category *angu paluhu* purely in terms of alliance, there then arises the question of what for the Rindi exactly distinguishes the relation of agnates, or 'clan mates' (*angu kabihu*), from other instances of the relation of *angu paluhu* (*paangu paluhungu*). In one respect the answer is obvious, namely that agnates derive exclusively from a single male ancestor. But as is clear from the case of clans that putatively descend from two brothers, what seems ultimately to separate them as non-agnates is a distinction of alliance connexions. It therefore appears that the categories *angu paluhu* and *angu kabihu* are not defined with regard to different sorts of relations but rather in terms of different relations of the same sort. Put another way, while agnates are distinguished from other groups by virtue of differences of alliance connexions, the relation of *angu paluhu* focuses upon a commonality of such con-

nexions. This has implications, then, for the distinction of alliance and descent in Rindi, as it shows that the two factors cannot be conceived entirely independently of one another. Nevertheless, descent and alliance are indeed opposed, and they serve different, though complementary, ends in the operation of the social order. Thus while alliance creates a distinction within the social body that entails a relation of inequality, patrilineal descent is a unifying principle which serves to perpetuate the groups that form the units of alliance; and it is consistent with this that the relation of agnates, by contrast to that of affines, is basically one of equality and identity. The positional equivalence of non-agnates who at some level share the same wife-givers (i.e., *angu paluhu* in the widest sense), on the other hand, involves an equality which resembles that of agnates but is not identical to it; for while agnates share two sorts of 'sources' (*pingi*) — patrilineal ascendants and wife-giving affines — persons reciprocally related as MZS who are not members of the same clan, for example, share only one.

4. Services

As is common in societies that practise asymmetric alliance, affines in Rindi perform certain complementary services for one another. By comparison with what is found elsewhere, however, the pattern seems to be somewhat less developed in this society. Furthermore, such tasks as are assigned to affines are mostly carried out by one group or category on behalf of the other, rather than, for example, by a genealogical MB (or his heir) on behalf of his ZS, as in other parts of eastern Indonesia. One reason for this may be the not uncommon practice, particularly among the nobility (who as noted generally set the pattern in customary usage), of taking wives from distant places, so that a man might meet his MB or ZC on only a very few occasions during his lifetime.

There are several services required of wife-taking groups. First, if a person dies away from home, his clan's wife-takers may be called upon to transport the corpse. Men of more than one wife-taking clan may be requested to assist in this, but in each case they should be affines of long standing. I have already mentioned the other services that are appropriately carried out by a wife-taker: the removal of the veil and the cords at the top of the corpse bundle, the cutting of the hair at the rite *kikiru matua*, and a child's first tonsure. That

wife-takers should be called upon to perform these services is consistent, first of all, with the fact that, among the nobility, these tasks are assigned to slaves (or, in one case, to commoners). Thus they can be described as duties performed by inferiors for superiors.²⁴ With regard to services involved in the funeral, however, the most relevant attribute of wife-takers, as 'feminine' affines, is perhaps their symbolic equivalence to the dead, which was demonstrated in Chapter IX. Specifically, the act of removing the veil and cords from the bundled corpse is analogous to the removal of the veil covering the bride's substitute after the bride is first brought to the wife-taker's village. I also remarked that the top of the corpse bundle corresponds to the hair, which at this point in the burial is symbolically untied, thus releasing the deceased's soul, or otherwise stated, his life. The fact that the hair is associated with the soul, then, may provide the link between this practice and that of cutting the hair. Also relevant here is the custom called *mangapa ditangu*, 'to take from above', whereby a wife-taker exercises the privilege of picking the first fruits of the wife-giver's newly planted betel, areca, banana, and coconut trees, and of receiving a female piglet from a first litter. The Rindi say these practices ensure that human as well as plant and animal reproduction will be continuous and unbroken (see also Onvlee 1973:145). Since the items taken are somewhat comparable to wives, in this case, then, it is evidently the wife-taker's act of receiving what is due to him — the realization of a vital connexion involving the unilateral transfer of material and immaterial qualities — that ensures the general prosperity.²⁵

There are three types of ritual services a wife-giver performs on behalf of a wife-taker. First, in cases of prolonged illness, a person may place himself under the spiritual protection of the ancestor of a wife-giver, in whose house he should remain until he recovers. This need not be the natal clan of the person's own mother or wife, and the procedure is normally resorted to only after recourse to one's own clan ancestor. The service requires a payment of a horse and metal valuables as the 'portion of the soul' (*tunggu hamanguna*) of the wife-giver's ancestor — which is then reciprocated with a cloth — and the offering of a pig and several fowls. A similar procedure may be followed when a woman is unable to conceive, though for this purpose the prestation is a little higher and should include two metal flakes to be consecrated to the ancestor after the woman has become pregnant. The couple remain in the wife-giver's house until the birth

has passed and longer if they so wish. In order to conceive, intercourse must take place in this house. These customs are called 'to subordinate oneself to a wife-giver' (*paatangu wiki la yera*), and 'to seek a stone with a space beneath, a shady tree, a safe cave, a dry loft' (*himbu watu mapalumbu, ai mapamaü, liangu mara, hindi mându*).²⁶ As noted, however, in cases of barrenness, endemic infant mortality, or particular illnesses (*murū*; see Chapter VI), more elaborate procedures, involving the services of clans whose ancestors hold special powers (e.g., the power of the 'cool water', *wai maringu mǎnjaku*), may be resorted to. Such groups, of course, need not be affines of the principal. Nevertheless, it is clear that in respect of their spiritual power, wife-givers in general are regarded as comparable to these.

A wife-giver's services are further required when a married woman commits adultery with a man of another clan, as in this circumstance it is her natal group that must approach the clan of the adulterer to exact compensation and take measures to normalize relations between the spouses. The payment, which consists of goods of the sort used as bridewealth, is then received not by the offended husband but by his wife's father or brother. One apparent reason for this is that, since the fine comprises valuables of the kind given in exchange for a wife, for the husband to receive it could imply a legitimization of an illicit sexual relation. Besides, as I shall demonstrate in Chapter XVI, the procedure appears to be mainly concerned with repairing the damage done to the alliance, which is seen as a threat to the well-being of the wife-taker, rather than with exacting material compensation for the cuckold.

The third instance of a service provided by wife-givers in Rindi concerns only the nobility. As noted, when a nobleman is buried it is his wife-givers who construct the small house (*kawarungu*) over the grave, which serves as the place of the soul until the mortuary rites are completed.

The nature of these various services suggests the previously mentioned idea of wife-givers as a source of life and spiritual well-being. Indeed, it is mainly in this respect, rather than with regard to temporal power, that their superiority lies. By contrast to a man's parents and the elders of his clan, therefore, a wife-giver's right to enforce obedience is restricted to matters that specifically concern the alliance; and they have no say in the internal affairs of the wife-taking clan. The spiritual superiority of the wife-giver is particularly evident in cases of illness, when a person places himself under the divine

patronage of the wife-giver's ancestor, who is thus shown to be a higher power than his own. Perhaps, then, it is by analogy with this usage that the practice of having the wife-giver build the mortuary house (*kawarungu*) can be understood. With regard to the condition of the soul, the transitional period before the deceased is fully incorporated into the afterworld is, after all, in most respects comparable to illness.

It is also relevant to these customs that, as I mentioned in Section 2, the alliance relation is represented as a house, specifically the house of the wife-giver. Another expression of this idea is an idiom employed in contracting marriage, when it is said of the wife-giver that 'he extends the verandah for him (the wife-taker) and adds to the house for him' (*na-pakajowanya bangga, na-pakikunya uma*). The wife-taker's house is then spoken of as 'a house added on' (*uma papakikungu*), which as noted otherwise denotes a house subsidiary to a clan's ancestral house, i.e., a 'cool house' (see Chapter I). While these phrases are particularly appropriate to certain simpler forms of marriage, some of which entail a period of uxorilocal residence for the groom (see Chapter XVIII), they were said also to express the relation of affines in general. In any case, it is not usual in Rindi for a wife-taker actually to live in the same building as his wife-giver. It thus appear to be rather with regard to its significance as something that affords spiritual benefit and protection that the house is an appropriate symbol here. Fully to avail himself of such benefit (as in the case of illness or childlessness), therefore, the wife-taker must physically place himself inside the wife-giver's house, thereby actualizing an aspect of their relation that is otherwise manifested only in words. Another indication of the wife-giver's concern for the wife-taker's spiritual well-being is the eastern Sumbanese custom, mentioned by Onvlee (1949:451), whereby a bride's *tuya* (MB) carries out an inspection of the bridewealth to ensure that it balances with the counter-prestation, since an excessive bridewealth would bring the woman misfortune (see further Chapter XVIII).

Despite these indications of the wife-giver's superior spiritual power, however, I never heard this party spoken of as a god (see Barnes 1974:249), a visible God (Singarimbun 1975:137), or the deputy of God (Vergouwen 1964:55), as is recorded for other Indonesian societies. Nor did I find any evidence that the wife-giver has any special power to curse or to impose other supernatural sanctions on recalcitrant wife-takers.²⁷ Thus, while a person may 'subordinate

himself' to a wife-giving clan in the event of childlessness, so far as I know the condition is not attributed to his having offended his wife-givers, as Vergouwen (1964:55-6) reports for the Toba Batak. The wife-giver's ultimate recourse, then, is simply to discontinue giving wives.

Finally, it is useful here to mention again the political aspect of the alliance relation. From what was said in Chapters X and XI, it is evident that, as it concerns the articulation of class standing, marriage can have quite pronounced political implications in eastern Sumba, and that in traditional times the marriage alliances of ruling noble and other prominent clans served to forge and consolidate political links between independent domains.²⁸ Traditional history also records instances where the reconciliation of a dispute was accompanied by an exchange of women in marriage, as, for example, in the case of the Rindi nobility and the clan Karindingu now established in Mangili, the basis of whose former enmity was mentioned in the Introduction (Section 3). Similarly, the long standing alliance between the Tabundungu nobility and Palai Malamba in Umalulu is said to have been initiated as part of a formal cessation of hostilities between these two clans. Yet, although the rank of a wife-taking lineage — and hence its political standing within its own domain — depends on maintaining existing alliance connexions, this does not entail that wife-givers are political superiors of wife-takers.²⁹ Indeed, owing to the tendency towards marriage with women of lower rank, often the reverse is the case. I would argue, then, that marriage alliance is not in itself a political institution, though the close connexion between groups that it involves can be exploited, by either party, for political ends.

5. Patterns of Behaviour

In this final section I shall consider how the inequality inherent in the alliance relation is reflected in attitudes and behavioural norms that concern both the two sorts of affines in general and more specific categories of affinal relatives. This, then, is also a convenient place to mention these aspects of other, non-affinal relations, particularly ones that involve close relatives.

In general, the Rindi regard their obligations to wife-givers as difficult to fulfil, and they consider it necessary to approach them with reserve and circumspection lest they be offended. Both ideas

are succinctly expressed in the maxim *mbotu lii payera*, 'heaviness, difficulty in matters concerning a wife-giver'. A wife-taker's obligations to a wife-giver include, first of all, the payment of bridewealth, which, though the amount can vary markedly, the Rindi generally characterize as expensive and burdensome. The wife-taker can further be required to provide his wife-giver with 'masculine goods' on occasions other than marriage, whenever the latter has need of them; and it is always possible to approach a wife-taking affine for material assistance of a more general kind, or, as the Rindi say, 'to go (to a wife-taker) to tell of troubles' (*lua papeka handuka*). A wife-taker should invariably be willing to help his wife-giver, it is said, so that the latter might remain well-disposed, particularly when it comes to requesting women in marriage. Wife-takers express their structural dependence in this regard by describing wife-givers in ritual speech as 'those who have pity that does not cease, consideration that is widely renowned' (*mapanamungu nda hawalu, mapaengu toma langu*).

Although it is not actually prohibited to request material help from wife-givers, the Rindi avoid doing so. Thus when building a new house, I was told, one would ask for help from agnates and wife-takers but not from wife-givers. Assistance in agricultural labour between affines who live close to one another, however, is freely given on a reciprocal basis, and as noted there are other occasions when the inhabitants of a village that includes affinally related lineages act together as a unit.³⁰ Also, despite the way in which the Rindi generally represent the relationship, it is by no means always the case that wife-givers are excessively demanding or take undue advantage of their position. Indeed, special care is sometimes taken to conciliate wealthy wife-takers in order to ensure their future co-operation in the provision of goods. Moreover, while wife-givers are owed respect, I found no pronounced pattern of deference or formality in daily encounters between affines, in which regard the relation contrasts noticeably with social intercourse between the nobility and the lower classes. Nevertheless, on formal occasions that involve an exchange of prestations, wife-givers and wife-takers are required to maintain a distance. The two parties then occupy different parts of the house and carry out negotiations through ritual speakers (see Chapter XVIII).

In accordance with the need to maintain reserve in the company of wife-givers, affines in Rindi are expressly forbidden to quarrel openly (*pahànggangu*) or to speak abusively (*tolangu*) to one another;

and though the rules are expressed reciprocally, the onus falls mainly on the wife-taker to avoid situations in which breaches might occur.³¹ In contrast, between agnates and non-affines, with the exception of closely related members of different generations or persons of opposite sex, such behaviour is within certain limits tolerated. Indeed, *tolangu*, 'abuse', which typically takes the form of calling someone names that refer to the genitals, is a common form of banter between non-affines. In this case usually no offence is intended or taken, and it is then sometimes said that such language is actually not *tolangu* at all.

For breaches of the above rules and for certain indiscretions involving women belonging to wife-giving groups (which I shall discuss just below), a wife-giver can demand material compensation. The wife-taker must then give a horse and two pendants with chains — reciprocated with a cloth — and slaughter a pig, as 'retribution to the wife-giver' (*ndoku la yera*). But although the Rindi say compensation can be demanded for even the most minor impropriety, no one could recall a single instance in which this had been done. This they attributed to the extreme circumspection with which they consistently treat wife-givers. During my stay, however, I heard of several cases of adultery with the WBW, an offence that requires a rather larger compensatory prestation, which is also called *ndoku la yera*.

Not surprisingly, regulated behaviours between affines of opposite sex display a more complex pattern than those that concern persons of the same sex. Female relatives who are the subject of special restrictions in Rindi can roughly be divided into two categories: members of wife-taking groups, viz., FZ (*mamu*), FZD (*anawini*), and married sister (*anawini*); and women of wife-giving groups, viz., WBW (*yera kawini*) and WM/MBW (*tuya kawini* or *ina yera*). The relation of SW (*rii ana*) and HF (*ama yenu*), which is also circumscribed in various ways, is ambiguous in terms of this distinction. I had little success in determining the extent to which the restrictions apply to all members of these relationship categories, though those concerning *yera kawini* were said to apply only to married women. While all the women listed above are of course prohibited in marriage, I never heard mention of any special restrictions regarding M, MZ, D, (unmarried) Z, or female relatives in the second ascending and second descending genealogical levels.

As regards FZ, FZD, and married sister, a man should avoid close

physical contact with these women; he should not enter their sleeping compartments; and he should refrain from engaging them in loose or suggestive talk (*payobu*). (Though it was specifically mentioned in these instances, the last prohibition in fact concerns all women who may not be married.) The rules also apply to WBW, WM/MBW, and SW, but in these cases there are other restrictions as well. Indeed, the most circumscribed relation of all in Rindi is that of WBW (*yera kawini*) and HZH (*layia mini*), and I was given a long list of (mostly reciprocal) behaviours that are prohibited between persons related in this way. These included giving or receiving something by hand; touching one another's personal possessions or garments, or hanging them up in the same place; sharing betel and areca; using and, especially, sticking the fingers inside the woman's lime container; sitting where the other has sat or mounting a horse ridden by the other; following after one another; and eating food or consuming drink left over by the other. In fact, owing to the degree of constraint the relationship requires, it is recommended that HZH and WBW avoid meeting one another altogether. Thus I was told that when a man visits his wife's brother's house, he should first ascertain the whereabouts of his WBW so that he might avoid running into her. Should he inadvertently meet her (e.g., on a path) he must then veer off to one side until she has gone by. The prescribed attitude of HZH and WBW is thus described as *pahilirungu*, 'mutual avoidance', which derives from *hiliru*, 'to step aside, get out of the way'.

While HF and SW are required to observe the other restrictions that apply to HZH and WBW, they need not, I was told, avoid passing things by hand, sitting in the same place, or following after one another. A prohibition that specifically concerns SW, on the other hand, is that of touching the betel containers of deceased persons in the category *ama yenu* (HF, HFB, etc.).³² Since father-in-law and daughter-in-law often share the same house, however, their relationship does not display the degree of avoidance characteristic of HZH and WBW. Thus while some people claimed the term *pahilirungu* could be applied to SW and HF, and to DH and WM, as well as to HZH and WBW, others thought it was only appropriate in the latter case. In addition, with regard to HZH and WBW, I was told that a breach of the prohibitions would make the woman infertile and cause the man 'to pass out' (*meti widi*);³³ but I never heard this said in reference to HF and SW, or indeed any other pair of relatives.

The relationship between a man and his WM or MBW is similarly marked by distance and reserve, though again not by strict avoidance. Of the restrictions that concern WBW and SW, moreover, the only one I know definitely to apply in this case in Rindi is the prohibition of consuming left-over food and drink. Interestingly, this is the one restriction that concerns all women of wife-giving groups but not those of wife-taking groups. Since both sorts of women are prohibited as sexual partners, the rule then does not reflect an exact symbolic equation of eating and sexuality; and perhaps all that can be said about it is that it is consistent with the distance that must be maintained between men of wife-taking and women of wife-giving groups.³⁴ With women of wife-taking groups, by contrast, a man's behaviour is, comparatively speaking, informal and familiar, and though I was unable to obtain much from direct questioning in this regard, relations between a woman and her brother's children seem on the whole to be quite close and affectionate.

While certain prohibited behaviours, especially those that concern WBW, have clear sexual connotations, it is evident, therefore, that differences in behavioural restrictions between different female relatives are not positively correlated with variations in marital or sexual availability. In fact, FZ, FZD, and Z (and, indeed, M and D), in respect of whom a man is subject to fewer formal restrictions, are the most strictly forbidden in marriage (see Chapter XV), whereas WBW, with whom a man is under the most constraint, is in a sense less prohibited as a spouse. Here I refer to the fact that unmarried women in the category *yera kawini*, which includes the WBW, may be taken as wives when one's own wife-givers, for whom these women are prescribed spouses, have no women available. The restrictions that concern WBW, therefore, apparently derive not from the structural entailments of asymmetric alliance — for according to generation and the unilateral prescription she would in fact be an appropriate spouse — but from the need to avoid an usurpation of the rights of male wife-givers. What I am suggesting, then, is that it is in a sense the very availability of the WBW that demands the high degree of behavioural constraint. As regards women in the category of WM or MBW, on the other hand, a difference of genealogical level presents a further formal obstacle to marriage. A similar case can be made for HF and SW, since before her marriage the woman belongs to the category *dawa* (WBC, etc.), and provided he has no 'sons' (*ana*) available to take the woman a man may in fact marry a female *dawa*.

It seems clear, therefore, that differences in behavioural restrictions between women of wife-giving groups (and SW) and those of wife-taking groups reflect in particular the respect that is owed to wife-giving affines and the need to maintain harmonious relations with them. Furthermore, in this regard a man's relation with women of wife-giving groups can be seen to involve a certain ambiguity, since as a male he is their superior, but as a wife-taker their inferior. As they are equal in respect of genealogical level, this is most marked in the case of WBW and HZH; and, recalling that wife-givers are classified as masculine and wife-takers as feminine affines, it seems relevant to point out that the terms for these two relatives, *yera kawini* and *layia mini*, can be translated as 'female wife-giver' and 'male wife-taker' respectively.

The relationship of prescribed spouses (*balu*) in Rindi is quite distinct from any other that involves persons of opposite sex; for not only are they free to indulge in sexually suggestive banter (*payobu*), but in certain contexts such behaviour is considered normal and desirable. It is most pronounced whenever men formally visit their wife-givers, on which occasions the guests engage in reciprocal joking and teasing with unmarried women of the house. The women might then also play practical jokes on the men, by placing hot pepper in drinking water and ash in lime containers, or by smearing the backs and bridles of their horses with dung. A man may discuss serious matters of a sexual nature (e.g., reproduction or menstruation) only with women in the category *balu*, or with elderly women classified as *àpu* ('grandmother') on the wife-giving side.

As for other categories of relatives: while a person should be obedient and respectful towards his parents and their siblings, and towards elder siblings, these relations are not usually distant or constrained. The relation of grandparents and grandchildren is expected to be close and affectionate, though I did not notice any marked contrast in this regard between grandparents and parents. But then the Rindi are not in any case a demonstrative people. While both parents and wife-givers are owed respect (*tembi*), persons I questioned were unable or reluctant to distinguish on this basis alone between a mother's brother and a father. On the other hand, they did speak of a difference in this regard between these two relatives and FZH. Thus I was told that the prohibitions that apply to male affines need not be observed (or at least not so strictly) between FZH and WBS; and in this respect the FZH was compared to an elder brother. This accords, then, with

the fact that the former relative is superior to ego only by virtue of his membership of a higher genealogical level. The Rindi do not articulate pronounced contrasts of attitude or affect with regard to the relation of opposite sex siblings and that of spouses. In fact, both relationships appear to manifest mainly positive qualities. It would be difficult, therefore, to draw up for them a scheme of the sort Lévi-Strauss (1963:42, 48) has called the 'atom of kinship'.

CHAPTER XIV

RELATIONSHIP TERMINOLOGY

Lists of relationship terms collected by Onvlee from 12 localities in eastern and western Sumba, some of which are indicative of prescriptive alliance, have been published in an article by Fischer (1957), who, adopting a mainly comparative approach, has described various terminological usages in relation to marriage rules and features of social organization.¹ The terminology employed in a single domain, however, has yet to be subjected to a comprehensive, formal analysis, or considered as a unitary classification of alliance and descent categories. A notable shortcoming of previous descriptions of Sumbanese relationship terms is that those employed by male and female ego, and the terms of reference and address, are not consistently distinguished. Since it has proved essential to the analysis to keep them apart, I have arranged the Rindi terms with their typical genealogical specifications in four separate lists in Tables 1 to 4.

Table 1. *Relationship Terminology (Terms of Reference, Male Ego)*

1. <i>umbu</i>	FF, FFB, FMB, MF, MFB, MMB (plus all male members of second and higher ascending genealogical levels)
2. <i>àpu</i>	FM, FMZ, FFZ, MM, MMZ, MFZ (plus all female members of second and higher ascending genealogical levels)
3. <i>ama</i>	F, FB, FFBS, FMZS, MFZS, MZH, MZHB
<i>ama maaya</i>	FeB
<i>ama maeri</i>	
or <i>ama kudu</i>	FyB
4. <i>ina</i>	M, MZ, MFBD, MMZD, FMBD, FW, FBW, FBWZ, WFZ
<i>ina maaya</i>	MeZ, senior wife of F when mother is junior wife
<i>ina maeri</i>	
or <i>ina kudu</i>	MyZ, junior wife of F when mother is senior wife

5. *tuya* MB, MFBS, MMZS, FMBS, MMBS, FBWB, MBWB, WMB, BWMB, MBW, MFBSW, MMZSW, MBWZ, FMBSW, MMBSW, FBWBW, MBWBW, WMBW, BWMBW
6. *ama yera* WF, WFB, MB, FBWB, MFBS, MMZS, MBWB, WMB, BWMB
7. *ina yera* WM, WMZ, MBW, MBWZ, WMBW
8. *kiya* FZH, FFBZH, FMZDH, MZHZH, ZHF, FZHZH, ZHFZH
9. *mamu* FZ, FFBZ, FMZD, MZHZ, ZHM, FZHZ, ZHFZ
10. *angu paluhu* B, FBS, MZS, FFBSS, MMZDS, FWS, MBDH, WZH, FZSWB, ZHBWB
11. *anawini* Z, FBD, MZD, FFBSD, MMZDD, FWD, FZSW, MBDHZ, ZHBW, DHM, FZD, FFBDD, FMZDD, ZHZ, FZDZH
12. *yera* MBS, MFBSS, MMZSS, WB, BWB, SWF, MBSWB, WBWB, MBSW, MBWBD, MMBSD, WBW, BWBW, SWM, MBSWZ, MBSWFBD, MBSWMZD
13. *balu* MBD, MFBSD, MMZSD, MMBDD, BW, FBSW, MZSW, WZ
14. *layia* FZS, FFBDS, FMZDS, ZH, FBDH, MZDH, DHF, FZDH, ZHZH, FZHZS, DH, BDH, MBDDH, ZDH, FZDDH
15. *papaha* W
16. *ana* S, BS, FBSS, MZSS, MBDS, WZS, MBSDH, D, BD, FBSD, MZSD, MBDD, WZD, ZSW, FZSSW
17. *dawa* MBSS, WBS, MBSWBS, ZS, FBDS, MZDS, ZDH, FZSS, ZHBS, FZDS, FZSDH, FZDDH, ZHZS, MBSSWB, MBSD, WBD, MBSWBD, ZD, FBDD, MZDD, FZSD, ZHBD, FZDD, FZDSW, ZHZD, MBSSW
18. *laleba* ZS, FBDS, MZDS, ZDH, FZSS, ZHBS, FZDS, FZDDH, ZHZS, DH, BDH, ZD, FBDD, MZDD, FZSD, ZHBD, FZDD, FZDSW, ZHZD, DHZ, BDHZ
19. *rii ana* SW, BSW, MBDSW, WBD, MBSD
20. *umbuku* SS, BSS, BDS, DS, ZSS, ZDS, SD, BSD, BDD, DD, ZSD, ZDD (plus all members of second and lower descending genealogical levels)
-

Table 2. *Relationship Terminology (Terms of Reference, Female Ego)*

1. <i>umbu</i>	FF, FFB, FMB, MF, MFB, MMB (plus all male members of second and higher ascending genealogical levels)
2. <i>àpu</i>	FM, FMZ, FFZ, MM, MMZ, MFZ (plus all female members of second and higher ascending genealogical levels)
3. <i>ama</i>	F, FB, FFBS, FMZS, MFZS, MZH, MZHB, HMB, ZHMB
<i>ama maaya</i>	FeB
<i>ama maeri</i>	
or <i>ama kudu</i>	FyB
4. <i>ina</i>	M, MZ, MFBD, MMZD, FMBD, FW, FBW, FBWZ, BWFZ, HMBW, ZHMBW
<i>ina maaya</i>	MeZ, senior wife of F when mother is junior wife
<i>ina maeri</i>	
or <i>ina kudu</i>	MyZ, junior wife of F when mother is senior wife
5. <i>tuya</i>	MB, MFBS, MMZS, FMBS, MMBS, FBWB, BWF, MBWB, BWMB, MBW, MFBSW, MMZSW, MBWZ, FMBSW, FBWBW, BWM, MBWBW, BWMBW
6. <i>kiya</i>	FZH, FFBDH, FMZDH, MZHZH, FZHZH, HFZH, ZHFZH
7. <i>mamu</i>	FZ, FFBD, FMZD, MZHZ, FZHZ, HFZ, ZHFZ
8. <i>ama yenu</i>	FZH, HF, HFB, ZHF, MZHZH, FZHZH, HFZH, ZHFZH
9. <i>ina yenu</i>	FZ, HM, HMZ, ZHM, MZHZ, FZHZ, HFZ, ZHFZ
10. <i>anamini</i>	B, FBS, MZS, FFBSS, MMZDS, FWS, MBDH, FZSWB, MBS, BWB, MBSWB
11. <i>angu kawini</i>	Z, FBD, MZD, FFBSD, MMZDD, FWD, MBDHZ, HBW, FZSW
12. <i>layia</i>	FZDH, HZH, HZHB, ZHZH, DH, ZDH, FZSDH, FZDDH, HZDH
13. <i>mangàlu</i>	FZD, HZ, ZHZ, FZDHZ, HZHZ
14. <i>rii anamini</i>	MBD, BW, FBSW, MZSW, MBSW, BWBW, BSWFZ
15. <i>balu</i>	FZS, FFBDS, FMZDS, FFZSS, ZH, FBDH, MZDH, HB
16. <i>lei</i>	H

17. <i>ana</i>	S, ZS, FBDS, MZDS, FZSS, HBS, BDH, MBDDH, D, ZD, FBDD, MZDD, FZSD, HBD, FZDSW, HZSW
18. <i>dawa</i>	BS, FBSS, MZSS, MBDS, BWZS, MBSS, BWBS, FZDS, HZS, FZDHZS, HZHZS, BD, FBSD, MZSD, MBDD, BWZD, MBSD, BWBD, FZDD, HZD, FZDHZD, HZHZD, MBDSW, BS
19. <i>laleba</i>	HZS, DH, ZDH, FZSDH, FZDS, FZDDH, FZDHZS, HZHZS, HZD, FZDD, FZDHZD, HZHZD
20. <i>rii ana</i>	BD, FBSD, MZSD, SW, ZSW, FZSSW, MBDD, BWZD, MBSD, BSW, MBDSW, MBSSW
21. <i>umbuku</i>	SS, BSS, BDS, DS, ZSS, ZDS, SD, BSD, BDD, DD, ZSD, ZDD (plus all members of second or lower descending genealogical levels)

Table 3. *Relationship Terminology (Terms of Address, Male Ego)*

1. <i>umbu</i>	FF, FFB, FMB, MF, MFB, MMB (plus all male members of second and higher descending genealogical levels), S, BS, FBSS, MZSS, MBDS, WZS, MBSDH, MBSS, WBS, MBSSWB, ZS, FBDS, MZDS, FZSS, DH, BDH, MBDDH, FZDS, ZHHS, FZSDH, FZDDH, SS, BSS, BDS, DS, ZSS, ZDS (plus all male members of second and lower descending genealogical levels)
2. <i>àpu</i>	FM, FMZ, FFZ, MM, MMZ, MFZ (plus all female members of second and higher ascending genealogical levels)
3. <i>ama</i>	F, FB, FFBS, FMZS, MFZS, MZH, MZHB, WF, WFB
4. <i>ina</i>	M, MZ, MFBD, MMZD, FMBD, FW, FBW, FBWZ, WFZ, WM, WMZ
5. <i>tuya</i>	MB, MFBS, MMZS, FMBS, MMBS, FBWB, MBWB, WMB, BWMB, MBW, MFBSW, MMZSW, MBWZ, FMBSW, MMBSW, FBWBW, MBWBW, WMBW, BWMBW
6. <i>kiya</i>	FZH, FFBDH, FMZDH, MZHZH, ZHF, FZHZH, ZHFZH
7. <i>mamu</i>	FZ, FFBD, FMZD, MZHZ, ZHM, FZHZ, ZHFZ
8. <i>aya</i>	eB, FBSe, MZSe, MBSe, FZSe, FWSe, eZH, WeB, eZ, FBDe, MZDe, MBDe, FZDe, FWDe, eBW, WeZ (all persons in ego's genealogical level [except W] who are older than he)

9. <i>eri</i>	yB, FBSy, MZSy, MBSy, FZSy, FWSy, yZH, WyB, yZ, FBDy, MZDy, MB Dy, FZDy, FWDy, yBW, WyZ (all persons in ego's genealogical level [except W] who are younger than he)
10. <i>ràmbu</i>	W, D, BD, FBSD, MZSD, MBDD, WZD, FZSSW, ZSW, SW, BSW, MBDSW, WBD, MBSSW, ZD, FZSD, FZDSW, FZDD, ZHZD, SD, BSD, BDD, DD, ZSD, ZDD (plus all female members of second and lower descending genealogical levels)
11. <i>dawa</i>	MBSS, WBS, MBSWBS, ZS, FBDS, MZDS, FZSS, ZHBS, FZDS, ZHZS, MBSD, WBD, MBSWBD, ZD, FBDD, MZDD, FZSD, ZHBD, FZDD, ZHZD
12. <i>inana i tamu</i>	SW, BSW, FBSSW, MZSSW, MBDSW

Table 4. *Relationship Terminology (Terms of Address, Female Ego)*

1. <i>umbu</i>	FF, FFB, FMB, MF, MFB, MMB (plus all male members of second and higher ascending genealogical levels), H, HB, FZS, ZH, FBDH, MZDH, FFBDS, FMZDS, S, ZS, FBDS, MZDS, FZSS, HBS, BDH, MBDDH, BS, FBSS, MZSS, MBDS, BWZS, MBSDH, MBSS, BWBS, FZDS, HZS, DH, ZDH, FZSDH, FZDHZS, HZHZS, FZDDH, HZDH, SS, BSS, BDS, DS, ZSS, ZDS (plus all male members of second and lower descending genealogical levels)
2. <i>àpu</i>	FM, FMZ, FFZ, MM, MMZ, MFZ (plus all female members of second and higher ascending genealogical levels)
3. <i>ama</i>	F, FB, FFBS, FMZS, MZH, MZHB, HMB, ZHMB, MFZS, HF, ZHF, HFB, FZHZH, HFZH, ZHFZH
4. <i>ina</i>	M, MZ, FW, FBW, FBWZ, FMBD, HMBW, ZHMBW, BWFZ, HM, ZHM, HMZ, FZHZ, HFZ, ZHFZ
5. <i>tuya</i>	MB, MFBS, MMZS, FMBS, MMBS, FBWB, BWF, MBWB, BWMB, MBW, MFBSW, MMZSW, MBWZ, FMBSW, FBWBW, BWM, MBWBW, BWMBW
6. <i>kiya</i>	FZH, FFB DH, FMZDH, MZHZH, FZHZH, HFZH, ZHFZH
7. <i>mamu</i>	FZ, FFBD, FMZD, MZHZ, FZHZ, HFZ, ZHFZ

8. *aya* eB, FBSe, MZSe, MBSe, FZSe, FWSe, eZH, FBDeH, MZDeH, HeB, HeZH, eZ, FBDe, MZDe, MBDe, FZDe, FWDe, eBW, FBSeW, MZSeW, HeZ (all persons in ego's genealogical level [except H] who are older than she)
9. *eri* yB, FBSy, MZSy, MBSy, FZSy, FWSy, yZH, FBdyH, MZdyH, HyB, HyZH, yZ, FBdy, MZdy, MBdy, FZdy, Fwdy, yBW, FBSyW, MZSyW, HyZ (all persons in ego's genealogical level [except H] who are younger than she)
10. *ràmbu* FZD, HZ, ZHZ, FZDHZ, HZHZ, D, ZD, FBDD, MZDD, FZSD, HBD, FZDSW, BD, SW, ZSW, FZSSW, BSW, MBDSW, MBSSW, FZDD, HZD, SD, BSD, BDD, DD, ZSD, ZDD (plus all female members of second and lower descending genealogical levels)
11. *dawa* BS, FBSS, MZSS, MBDS, BWZS, MBSS, BWBS, FZDS, HZS, FZDHZS, HZHZS, BD, FBSD, MZSD, MBDD, BWZD, MBSD, BWBD, FZDD, HZD, FZDHZD, HZHZD
12. *inana i tamu* SW, ZSW, FZSSW, BSW, MBDSW, MBSSW

1. General Remarks

A number of subsidiary distinctions and usages not indicated in the Tables should first be mentioned. With terms that include both male and female specifications, sex can be indicated by the addition of *kawini* (or *tau kawini*), 'female, woman', or *mini* (or *tau mini*), 'male, man'. As regards the categories *tuya* and *yera*, it is almost always the women, and with *layia* (w.s.) the men, who are singled out in this way.² With other terms the distinction of male and female is made about equally. It will be noted that the term for 'son', *ana mini* (male child) is therefore apparently identical to the women's term for 'brother', *anamini*. Being a compound, however, the latter is recognized in speech by the placing of the possessive pronoun after the second root; thus, *anamininggu* is 'my brother' while *anangu mini* is 'my son'. As noted previously, *ana kawini*, 'daughter', and *anakawini*, 'wife-taker', are distinguished in the same way.

Umbu-àpu, a juxtaposition of the grandparent terms, denotes ancestors, while *ana-umbuku*, the terms for children and grandchildren, are conjoined collectively to designate descendants.³ As *umbu*, *àpu*, and *umbuku* are further applied beyond the second

ascending and descending generations respectively, the terminology thus distinguishes just five genealogical levels. However, persons in the third ascending generation can when necessary be specified as *pandua umbu*, 'twice *umbu*', or *pandua àpu*, 'twice *àpu*', while those in the third descending generation can similarly be designated as *pandua umbuku*, 'twice *umbuku*'. Presumably the next ascending level could be distinguished as *pandailu umbu*, 'thrice *umbu*', and so on, though I cannot recall ever having heard these expressions employed.

Persons classed as *ama* and *ina* can further be distinguished according to age relative to ego's own parents by the addition of *maaya*, 'older', and *maeri*, 'younger'. A more common way of indicating parents' younger siblings, though, is the modifier *kudu*, 'small, minor'.⁴ Where relative age is indicated, it is more usually the younger who is specified. If ego's mother is his father's first wife, then *ina kudu* (MyZ, etc.) is also employed for junior wives, regardless of their ages relative to the mother's. Accordingly, a wife who preceded ego's mother in marriage is called *ina maaya* (MeZ, etc.). The criterion in this case is thus not relative age as such, but a broader notion of seniority or, as the Rindi express it, 'which woman arrived first in the father's house'. A man may similarly distinguish his wives, irrespective of their ages relative to one another, as *papaha mamaaya*, 'senior wife', and *papaha mamaeri*, 'junior wife'. Another phrase referring to the first wife is *papaha rànja lunggi*, 'wife whose hair is the same length (as her husband's)', which indicates that the spouses are of the same level of maturity, i.e., that they have been married the same length of time. Co-wives refer to one another as *rii rua*; *rua* is a variant of *dua*, 'two', while here *rii* is to be understood as 'wife'. The birth order terms are: *ana mamaaya* or *ana tuhangu*, 'eldest, first born child'; *ana tu padua* ('child placed in the middle'), 'middle child'; and *ana mamaeri* or (*ana*) *eri baba*, 'youngest child'. *Baba* is 'lap', 'to carry on the lap'.

Closely related men in the category *tuya* are called *polangia* (or *pulangia*) or *tuya polangia*, the etymology of which term I discussed in the last chapter. While on several occasions it was defined for me as 'the full brother of ego's mother', I found that in practice informants tended to apply it more widely. Indeed, one man, after defining the term in precisely this way, then proceeded to classify almost all men of wife-giving groups of his clan whom he called *tuya* as *polangia*. The usage, therefore, is not restricted to ego's mother's full brothers, and it is not possible to define its exact limits by genealogy alone.

Its usual range of application, however, I would estimate to include, besides the genealogical mother's brother, male siblings and close agnates of women whom closely related members of ego's group have taken in marriage; unlike *tuya*, it is not applied, for example, to MBWB. Close female relatives in the prescribed category *balu* (MBD, etc.), particularly the genealogical mother's brother's daughter, therefore, are alternatively called *ana polangia*, 'child of *polangia*'. The children of *tuya* (MB) and *mamu* (FZ) are moreover occasionally referred to as *ana tuya* and *ana mamu* (*ana*, 'child of'). For female and male ego respectively these terms are used to specify persons of the opposite sex, viz., MBS and FZD, within the wider categories *anamini* and *anawini*.

A spouse is sometimes called *tau angu*, from *tau*, 'person, body', and *angu*, 'companion'. *Angu* alone is a rather informal way of addressing a spouse. A man sometimes refers to his wife as *taunggu*, 'my person', a usage which, in context, might also indicate one's slave. Another word occasionally used for 'spouse' is *mbapa*, 'partner, companion', a variant of *papa*, 'one member of a pair' (see Chapter III, Section 1); and for 'husband' *mini mbapa* ('male partner').⁵ The usual term for 'husband', *lei* (or *mini lei*), is related to Indonesian *laki*, 'man, male', 'husband'. *Papaha*, 'wife', is a derivative of *paha*, 'to pair, fit (together)' (cf. Indonesian *pasang*), and so literally means someone with whom a man is paired. In ritual speech the term is conjoined with *pateki*, from *teki*, 'to take (*inter alia*, in marriage)'.⁶

Full siblings of either sex can be specified as *angu dedi*, 'companions in birth', a term that closely resembles *angu paluhu* (B, FBS, etc., m.s.), 'companions in emergence'. In ritual speech, *angu paluhu* is occasionally paired with the synonymous *angu mini*, 'male companion', which thus corresponds to the women's term for 'sister', *angu kawini*, 'female companion';⁶ but it is never employed in ordinary reference. There are no special terms for half-siblings.

As in the English idiom, relatives in Rindi can be distinguished as 'close' (*mareni*) or 'distant' (*marau*). More commonly, though, distant relations are indicated with the phrase *tu palembarungu*, 'at a remove' (from *tu*, 'to place' and *lembaru*, 'to pass by, over'), which is then placed after the primary term. The distinction is applied within both ego's and adjacent lines. It is not possible to define on genealogical grounds the point at which a given relation becomes distant; but in contrast to lines immediately adjacent to ego's own, all persons in the same categories but in lines further removed (e.g., MBWB, *tuya*;

FZHZH, *kiya*) are *tu palembarungu*. The Rindi also designate distant relatives with phrases such as *tambaru paama*, 'on the father's (*ama*) side', *tambaru patuya*, 'on the mother's brother's (*tuya*) side', and so on.

Closely related members of a category, on the other hand, are distinguished with the modifier *wiki*, which usually translates either as 'own' (as in *uma wiki*, 'own house') or 'self' (as in *parotu wiki[ngu]*, 'to restrict, deny oneself'). Curiously, however, the word is not confined to individual genealogical relatives as one might expect, but implies a more general notion of closeness of relationship. *Ina wiki*, 'own mother', for example, can thus further be applied to mother's full sisters and, I was told, to FBW and FMBD as well, though the father's other wives were said not to be *ina wiki* unless they are simultaneously siblings of ego's mother. It is also worth noting that the genealogical FZD is not considered an *anawini wiki*, 'own sister', while MZD, provided her mother is a full sibling of ego's own, can be. *Wiki* seems often to be employed in a relative way. Thus whereas FB, for example, might be called *ama wiki* in contrast to more distantly related *ama*, in distinguishing this relative from ego's own father he would not.

Apparently, then, the Rindi lack terms which specify absolutely own parents or other genealogical relatives. With regard to ego's own mother, in response to questioning I was once given the phrase *ina maàpangga kalorungu*, 'mother who held the rope on my behalf' (which alludes to the method of delivering a child); but I doubt whether this is a common usage. Similarly, men in the category *ama* other than ego's own father may be distinguished from the latter with the circumlocution *ama hau biliku*, 'father of another compartment', which refers to the occupation of single sleeping compartments in the house by married couples.⁷ In ritual speech, close relatives are indicated with the phrase *mata mitingu*, as in *tuya mata mitingu*, 'own mother's brother', the ordinary equivalent of which is *tuya wiki*. *Mata mitingu* is the pupil of the eye (*mata*, 'eye'; *mitingu*, 'black'), and so specifies persons who as it were occupy the core or nucleus of a relationship category. In view of my remarks concerning *wiki*, however, I cannot be sure whether it applies only to genealogical relatives; and while logically the phrase can modify any category, I only encountered it with the terms *ina*, *tuya*, and *layia*.

Although there is not sufficient space here to explore the etymology of the relationship terms, the distribution and possible derivation of

certain words are worthy of a brief mention. Apart from Rindi, *kiya* (FZH, etc., sometimes written as *kia*) is found in eastern Sumba only in Mangili and Umalulu, though it appears again as the term for FZH in western Sumba (Wawewa and Lauli), in the form *ki'a*; in Kodi the same term is used for FZ. It is not clear whether the word is related to *kia* (usually rendered as *makia*), 'shame', 'embarrassment', 'shyness', but this remains an interesting possibility. *Leba*, the root of *laleba* (ZC, etc.), also appears in the form *kaleba*, which Kapita (1974) gives as 'seedling'. This seems significant in respect of the derivation of *polangia* (MB, etc.) from *pola*, 'trunk', and the fact that *wini*, as in *anawini* (Z, etc.), has the meaning of 'seed'.⁸ *Wini*, however, could just as well be construed here as 'female' (cf. *kawini*; and *anamini*, 'male child, person', B, etc., w.s.). *Layia* (FZS, ZH, etc.) is also the word for ginger, but in this sense the term appears to have a different derivation (see Dempwolff 1938:96). *Yenu* occurs only in the terms for HF and HM (*ama yenu*, *ina yenu*) and currently has no independent use. I also found no other meaning for *yera* (MBS, WB, etc., 'wife-giver'). The rest of the relationship words are mostly cognates of ones commonly found in other Indonesian languages. (The derivation of terms used by members of alternate generations is mentioned in Section 5 below.)

2. Analysis: Reference Terms (Male Ego)

Features of the men's terminology of reference that indicate a social order of lineal descent include:

F = FB	FB ≠ MB	FB ≠ FZH
M = MZ	MZ ≠ FZ	
B = FBS = FFBS	FBS ≠ MBS	FBS ≠ FZS
	MBS ≠ FZS	
Z = FBD = FFBS	FBD ≠ MBD	
S = BS = FBSS	BS ≠ ZS	BS ≠ WBS
D = BD = FBSD	BD ≠ ZD	BD ≠ WBD

Lineality is not expressed at all in the second ascending or second descending genealogical levels. The only instance of a vertical equation is ZH = DH (*layia*). But this is not reciprocated (i.e., WF ≠ WB); and as it applies only to affinal specifications in the descending level, it does not indicate conclusively whether the terminology is one of patrilineal or matrilineal descent. Since Rindi institutions are clearly governed by patriliney, however, the terms may be ordered in accord-

ance with this principle, as I have done in Table 5. With regard to the virtual absence of vertical equations, it should further be noted that the Rindi terminology does not exhibit the general feature found in some other terminologies of asymmetric alliance, whereby the same terms designate both wife-givers and ascending levels on the one hand and wife-takers and descending levels on the other.

The following equations and distinctions are indicative of an asymmetric prescription:

$$\begin{array}{lll}
 \text{FB} = \text{MZH} = \text{MFZS} & & \\
 \text{MZ} = \text{FBW} = \text{FMBD} = \text{WFZ} & & \\
 \text{MB} = \text{WF} & \text{MB} \neq \text{FZH} & \text{FZH} \neq \text{WF} \\
 \text{MBW} = \text{WM} & \text{MBW} \neq \text{FZ} & \text{FZ} \neq \text{WM} \\
 \text{MBWB} = \text{WMB} & & \\
 \text{MBWBW} = \text{WMBW} & & \\
 \text{FZ} = \text{ZHM} & \text{MBW} \neq \text{ZHM} & \\
 \text{FZH} = \text{ZHF} & \text{MB} \neq \text{ZHF} & \\
 \text{MBS} = \text{WB} & \text{MBS} \neq \text{FZS} & \text{WB} \neq \text{ZH} \\
 \text{MBD} = \text{BW} = \text{WZ} & \text{MBD} \neq \text{FZD} & \text{WBW} \neq \text{Z} \\
 \text{FZS} = \text{ZH} & & \\
 \text{FZD} = \text{ZHZ} & & \\
 \text{ZS} = \text{DH} & & \\
 \text{MBSD} = \text{WBD} = \text{SW} & \text{SW} \neq \text{ZD} & \text{WBS} \neq \text{ZS}
 \end{array}$$

The equation $Z = \text{FZD}$ is consistent with a prohibition of marriage with the FZD .⁹ The terms may thus be ordered according to a scheme of asymmetric alliance as in Table 5.

As is shown by the equations $\text{MB} = \text{MBWB}$, $\text{MBW} = \text{MBWBW}$, $\text{FZH} = \text{FZHZH}$, $\text{FZ} = \text{FZHZ}$, and the distinctions $\text{MBW} \neq \text{FZHZ}$, $\text{FZ} \neq \text{MBWBW}$, and $\text{MBSW} \neq \text{FZD}$, the terminology does not define a closed cycle of alliance relations between component lines. Wife-givers of wife-givers are thus classified with wife-givers, and wife-takers of wife-takers with wife-takers. In principle, the terms may be extended in either direction *ad infinitum*; so there is no predetermined point at which persons in the wife-taking or wife-giving directions (on the left and right respectively in Table 5) systematically become classified as wife-givers or wife-takers. Where cyclical relations between groups do occur, however, the terms, I was told, would be applied according to which relation was considered the closer. Thus, when FZH is at the same time MBWB , for example, this relative would be called *kiya* (FZH , etc.). Yet affines of affines are not classified identically to affines in all particulars, since the line of wife-givers of wife-givers is distinguished from that of own wife-

**Table 5. Categories of Descent and Alliance
(Reference Terms, Male Ego)**

(f)	(m) ←	(f)	(m) ←	(f)	(m) ←	(f)	(m) ←	(f)	(m)
àpu	umbu	àpu	umbu	àpu	umbu	àpu	umbu	àpu	umbu
	kiya	mamu	kiya	mamu	ama	ina	tuya ama yera	tuya ina yera	tuya
	layia	ana- wini	layia	ana- wini	angu paluhu (EGO)	balu	yera	yera	yera
dawa laleba	dawa laleba layia	dawa laleba	dawa laleba layia	ana	ana	dawa rii ana	dawa	dawa	dawa
umbuku									

**Table 6. Categories of Descent and Alliance
(Reference Terms, Female Ego)**

(m) ←	(f)	(m) ←	(f)	(m) ←	(f)	(m) ←	(f)	(m) ←	(f)
umbu	àpu	umbu	àpu	umbu	àpu	umbu	àpu	umbu	àpu
		kiya ama yenu	mamu ina yenu	kiya ama yenu	mamu ina yenu	ama	ina	tuya	tuya
	mangàlu	layia	mangàlu	balu	angu kawini (EGO)	anamini	rii anamini	anamini	rii anamini
dawa laleba layia	dawa laleba	dawa laleba layia	ana	ana	dawa rii ana	dawa	dawa rii ana	dawa	dawa rii ana
umbuku									

givers by the use of *yera* (*kawini*) for WBW, MBSW, etc. Similarly, for female ego, *layia* (*mini*) (HZH, FZDH, etc.) distinguishes the husband's line from that of his wife-takers. To represent the classification adequately, therefore, it is necessary to include at least five lines.

Since *yera* is also the generic term for wife-givers, *ama/ina yera* (WF, MB; WM, MBW) may be glossed either as 'father and mother of *yera* (MBS, etc.)' or as 'wife-giving mother and father'. As is evident from their genealogical specifications, the distinction between these terms and *tuya* (MB, MBW, etc.) is not straightforwardly one between affinal and cognatic relatives. Thus, while a wife's parents and their same sex siblings are not called *tuya*, an unmarried man can alternatively refer to MB and MBW as *ama/ina yera*. Before marriage, however, he should not address them as *ama* and *ina*. Whereas the address terminology distinguishes WF and WM from MB and MBW, therefore, the reference system evidences a degree of overlap. There was considerable disagreement concerning who may be called *ama/ina yera*. My records show that some people wished to classify MFBS and FWFBS as *ama yera*, while others did not, but there were also instances where more distant relatives, e.g., MFFBSS, were referred to with this term. Certain informants thought *ama/ina yera* might be appropriate for WMB, MBWB, and WMBW as well, though everyone agreed that *tuya* was the more suitable term for these relatives; and I was assured that they cannot be called *ama* and *ina* in address. Moreover, I seem not to have encountered MBWBW as *ina yera*, and some claimed it was decidedly wrong. Since in comparison with *tuya*, *ama/ina yera* more definitely connote an alliance connexion, therefore, I have the impression that before marriage the terms are normally applied only to closely related matrilineal cognates and parents-in-law of close agnates, thus in a way similar to *polangia*. In this regard, *ama/ina yera* and *tuya* generally correspond to *ama/ina yenu* and *kiya/mamu* in the women's reference terminology.

Dawa is employed for all persons in the first descending genealogical level except those in ego's own line. Within the three medial levels, therefore, it is the only reference term applied bilaterally to include both wife-giving and wife-taking categories. Persons on the wife-taking side, however, are alternatively called *laleba* (ZC, FZDC, etc.), though for these relatives, too, *dawa* seems to be the more common form of reference. *Layia* is considered the more formal and respectful designation for affines in the first descending generation,

and is always used in place of *laleba* in ritual language. Calling the DH *layia* thus apparently serves to modify the subordinate position of this relative as both a wife-taker and a member of a lower genealogical level. *Rii ana*, '(prospective) wife of *ana* (child)', refers primarily to affinal positions (SW, BSW, MBDSW, etc.), though according to my records it may also be used for prospective wives of ego's sons (WBD, MBSD, etc.). As in the case of DH, while *dawa* is the alternative term for unmarried women in this category, it is not a proper form of reference after they are married.

Despite these qualifications, then, the first descending genealogical level is marked by a degree of redundancy not found elsewhere in the terminology, and this is largely due to the extensive bilateral application of *dawa*, which is somewhat uncharacteristic of asymmetric alliance. In this respect, however, the Rindi terminology appears to differ from those found elsewhere in eastern Sumba. Thus for Kambera, Wielenga (1909a) and Kapita (1967a:111) list *dawa* as BC (w.s.) alone, while Onvlee (in Fischer 1957:14) mentions it only as the address term for BC (w.s.), WBC and ZC (m.s.), HZC.¹⁰ Considering its range of application in Rindi, *dawa* is surprisingly absent from the otherwise comprehensive lists of relationship words by Pos (1901) and Wielenga (1917). It is possible, therefore, that *dawa* was once not employed in reference for members of wife-taking lines in Rindi, so that formerly the terminology was more consistently asymmetric than at present.

3. Principles of Classification

The component categories of the men's reference terminology exhibit three principles of classification: genealogical level, alliance status (the distinction of wife-givers, wife-takers, and what I have called 'co-affines'), and sex. There are no reference terms defined by relative age. For the Rindi each of these principles distinguishes superiors from inferiors; thus descending genealogical levels are subordinate to ascending, wife-takers to wife-givers, and females to males.

The virtually complete distinction of genealogical levels is the most consistently applied of the principles, and the categories thus distinguished are applied in accordance with this criterion alone;¹¹ they are in no way influenced by the relative age of the person referred to. Since the system is asymmetric, the principle of alliance status actually governs two sorts of contrasts: that between ego's and

adjacent lines, and that between wife-givers and wife-takers. In those genealogical levels where the latter contrast is in evidence, the single exception to it is *dawa*. The former distinction, on the other hand, is disregarded in ego's level, where *anawini* is applied to women in the wife-taking line (FZD, etc.) as well as to those in ego's own line (Z, FBD, etc.). Accordingly, a woman calls both B and MBS *anamini*. The fact that *anawini* (and in the women's terminology, *anamini*) is the only term in ego's line and genealogical level which is further applied to an adjacent line appears to be significantly in accordance with the classification of wife-takers of wife-takers as wife-takers, and wife-givers of wife-givers as wife-givers. This is not to argue, however, that the terms for own affines are applied to these lines simply as a logical consequence of the equation of Z and FZD.

Although whether a relative is male or female can always be indicated by the addition of the modifiers *mini* and *kawini*, so far as primary terms are concerned sex is the least consistently applied criterion of classification. Thus of the total of 19 terms¹² employed by male ego, six do not specify the person's sex. Since four of these terms (*ana*, *dawa*, *laleba*, and *umbuku*) designate categories in descending generations (for which there are six terms in all), it might be considered that in these instances, because their inferiority to ego is already established by genealogical level, it is not required further to distinguish them by sex. Moreover, if one were to exclude *rii ana* (SW, etc.) and *layia* (DH, etc.) on the not unreasonable grounds that they denote only specific sub-classes of actual or, in the former case, prospective affines, then none of the terms in the lower levels would specify sex. The two other neuter terms (*tuya* and *yera*), by contrast, refer to persons who are superior to ego by virtue of alliance status, and, in the first case, by generation as well; so here it may be supposed that alliance, in particular, provides a sufficient basis of classification and hence obviates the need to designate these relatives with primary terms that are sexually distinctive. Conversely, where alliance status is not expressed within a higher genealogical level (*viz.*, *umbu* and *àpu*) sex is indeed distinguished. The use of single terms for persons of both sexes further accords with a feature of the system I shall discuss below, whereby in terms of alliance a woman is classified with her (prospective) husband's line. Thus, with the necessary exception of *ana*, all the neuter terms apply to spouses as well as to sibling pairs. As is common in prescriptive classifications, alliance status is not distinguished in the second ascending and second

descending genealogical levels;¹³ while *umbuku* (CC, etc.) has the additional peculiarity of being the only term that specifies nothing other than genealogical level.

4. Analysis: Reference Terms (Female Ego)

Indications of lineal descent in the women's reference terminology are of the same order as those encountered among the men's terms; so the feature requires no further demonstration here. The following equations and distinctions symptomatic of asymmetric prescriptive alliance, however, are specific to female ego:

FZ = HM	FZ ≠ MBW	MBW ≠ HM	FZS = ZH = HB		
FZH = HF	FZH ≠ MB	MB ≠ HF	FZD = HZ = ZHZ		
FZHZ = HFZ			FZDH = HZH		
FZHZH = HFZH			Z = FZSW = MBDHZ		
MB = BWF	FZH ≠ BWF		B = FZSWB = MBDH		
MBW = BWM	FZ ≠ BWM		MBD = BW	MBD ≠ ZHZ	BW ≠ ZHZ
			MBS = BWB	MBS ≠ ZH	BWB ≠ ZH
S = FZSS				MBD ≠ FZD	
D = FZSD				MBS ≠ FZS	
ZS = BDH					
ZD = FZDSW					
BS = MBDS	BS ≠ DH				
BD = MBDD = SW	BD ≠ DHZ				
DH = HZS = FZDS					

While most of my remarks concerning the men's reference terminology apply equally to the women's, it is immediately apparent that the latter is systematically adapted to accord with the fact that a woman is destined to be transferred upon marriage to a wife-taking group.¹⁴ Thus *layia* (which as noted is also a term for wife-takers in general) is applied not to the wife-takers of her brother's line, but to those of her prospective spouse (*balu*). There are no positions for which a woman employs the term *yera* ('wife-giver'). Insofar as she can be said to have wife-givers, they can only be those of her (prospective) husband, in other words her brother's (*anamini*) line; so as regards alliance status a woman is identified with her natal group's wife-takers.¹⁵ The terms of the first descending generation are then distributed accordingly.

The women's term *rii anamini* (MBD, BW, MBSW, BWBW, etc.) may be glossed as '(prospective) wife of brother'. Fischer (1957:14), who makes the mistake of translating *rii* only as 'wife', questions whether the term can correctly be applied to MBD before her marriage. For Rindi, at least, the answer is affirmative; there is indeed no other

term that can be used for this relative. Two senses of *rii* are relevant to its use in this and in other designations (see *rii ana*, SW, etc.; *rii rua*, 'co-wife'), viz., 'side-dish' and 'bone'.¹⁶ In the first sense, *rii* refers to a portion of food that renders a staple (rice or maize) palatable and which forms its essential complement. A side-dish is thus described as 'something which makes eating possible' (*pangangu wàngu*). Informants also construed *rii* in this context as 'bone', with especial reference to the limbs, and more generally as something that lends strength and support. The derivative *parii*, 'having bones', means 'strong, sturdy'. By both interpretations, therefore, a (prospective) wife is represented as the essential complement of her husband; so a married couple compose a unity.

According to my records, a woman can refer to her MBSD, BSW, and MBSSW, as well as to her own SW and BD, with the term *rii ana*, whereas a man applies it only to the category of SW and WBD. Though the difference follows logically from female ego's classification of MBS and MBSWB as *anamini*, and their (prospective) wives as *rii anamini*, the usage is curious in that *rii ana* means '(prospective) wife of *ana*', while the (prospective) husbands of MBSD, etc., are in fact called *dawa*.¹⁷ There is thus some reason to doubt that *rii ana* is a correct or, at any rate, a usual designation for these women.

The principles of classification revealed in the men's terminology apply in virtually the same way to the women's. Again the distinction of genealogical levels is the most consistent, being expressed in all but one instance (i.e., *layia*, HZH, DH, etc.). Wife-givers and wife-takers are distinguished from one another or from ego's own line in 14 of the 19 men's terms and in 15 of the 20 women's. Sex is not specified in 5 terms employed by female ego whereas in the men's terminology the total is 6. The difference is accounted for by the exclusively female term *mangàlu* (FZD, HZ, etc.). Though this relative is the prescribed spouse of *layia*, she is not classed with her (prospective) husband as is a man's female *yera* (MBSW, WBW, etc.). For female ego, therefore, *layia* is an exclusively male category.

Although the distinction of alliance in the women's terminology is as extensive as in the men's, as noted just above its implications are markedly different. Thus, while for a man wife-givers are unequivocally superior to wife-takers, for a woman, particularly in respect of her line of origin and that of her prospective husband, this is not so clearly the case. Upon her marriage, jural authority over a woman is relinquished by her father's group in favour of his wife-takers; so

she becomes directly subordinate to her husband and his parents. In addition, as an outsider, the relation of a woman and her parents-in-law combines authority with an element of distance and formality which thus contrasts with the relation of a woman and her own parents. The same applies to the relation of a woman and her HZ, *mangàlu*, to whom she owes a degree of deference which (apart from the factor of relative age) is absent from the relation of sisters.¹⁸ For a woman, therefore, *mangàlu* connotes a category superior to *angu kawini* (Z, etc.), while for a man the reverse is the case with *layia* (FZS, ZH, etc.) and *angu paluhu* (B, etc.). Thus as regards the distinction of alliance status, relations of subordination among women appear to be ordered inversely to those which obtain among men.

5. Terms of Address

The men's and women's terms of address may conveniently be discussed together. The most apparent difference between the reference and address terminologies is that the latter contain considerably fewer terms. This follows from the fact that, with two exceptions (*ràmbu* and *inana i tamu*), all the address terms are used, albeit with a different range of specification in some cases, in reference, while over half of the reference terms (counting the men's and the women's terminologies separately) cannot be employed in address. Although *aya* and *eri* ('elder' and 'younger sibling, etc.') are also used in reference, in this context they indicate no more than the age, of any individual, in relation to ego's (see, e.g., *erimanggunyaka*, 'he is younger than I'). As vocative usages, on the other hand, *aya* and *eri* can properly be used only for person's in ego's genealogical level; so for this reason I have listed them only under terms of address.

As regards the distinctions exhibited in the reference terminology, the system of address is of diminished significance. Lineal descent is systematically indicated only in the first ascending genealogical level, though here too the distinction of ego's and adjacent lines is partly obscured by the application of *ama* and *ina* to parents-in-law; thus the number of equations symptomatic of asymmetric prescriptive alliance is also greatly reduced (see Tables 7 and 8). For male ego, this latter feature is evidenced mainly in respect of *mamu* (FZ=ZHM) and *kiya* (FZH=ZHF), and for female ego with regard to *tuya* (MB=BWF, MBW=BWM). Equations and distinctions found in other genealogical levels are not definitive.

**Table 7. Categories of Descent and Alliance
(Address Terms, Male Ego)**

(f)	(m) ← (f)	(m) ← (f)	(m) ← (f)	(m) ← (f)	(m) ← (f)	(m) ← (f)	(m) ← (f)	(m)	
àpu	umbu	àpu	umbu	àpu	umbu	àpu	umbu	àpu	umbu
	kiya	mamu	kiya	mamu	ama	ina	tuya ama	tuya ina	tuya
aya/cri (EGO)									
dawa	dawa	dawa	dawa	ràmbu	umbu	ràmbu	dawa	dawa	dawa
ràmbu	umbu	ràmbu	umbu	ràmbu	umbu	ràmbu	inana i tamu	umbu	ràmbu
ràmbu	umbu	ràmbu	umbu	ràmbu	umbu	ràmbu	umbu	ràmbu	umbu

**Table 8. Categories of Descent and Alliance
(Address Terms, Female Ego)**

(m) ← (f)	(m) ← (f)	(m) ← (f)	(m) ← (f)	(m) ← (f)	(m) ← (f)	(m) ← (f)	(m) ← (f)	(m) ← (f)	
umbu	àpu	umbu	àpu	umbu	àpu	umbu	àpu	umbu	àpu
		kiya ama	mamu ina	kiya ama	mamu ina	ama	ina	tuya	tuya
aya/eri (EGO)									
dawa	dawa	dawa	ràmbu	umbu	dawa	dawa	dawa	dawa	dawa
umbu	ràmbu	umbu	ràmbu	umbu	ràmbu	inana i tamu	umbu	ràmbu	umbu
umbu	ràmbu	umbu	ràmbu	umbu	ràmbu	umbu	ràmbu	umbu	ràmbu

One difference between the men's and women's terminologies of address appears in the application of *ama* and *ina* to adjacent lines. First, I have it on record that female ego may address FZH as *ama* before her marriage. If this is correct, it would seem to follow mainly from the fact that a woman's FZH prospectively holds direct authority over her. However, not only was the usage unconfirmed by my own observations, but FZ was given only as *mamu*; and though, at least once, *ina* and *ama* were said to be appropriate address terms for MZH and MZHZH as well, again I suspect this may not apply before female ego's marriage to a man of the prescribed category. In all these cases, moreover, *mamu* and *kiya* were indicated to be the more usual forms of address. But, on the other hand, with supplementary evidence derived from my genealogical records I was able to corroborate that a married woman may address HFZ, FZH, and HFZH, FZHZH as either *mamu* and *kiya* or *ina* and *ama*, which thus contrasts with a married man's exclusive use of *tuya* to address WMB, MBWB, and WMBW, MBWBW. Ultimately, I think, the difference must be ascribed to the fact that distinctions of alliance status are of diminished significance for a woman. It is also worth noting here that *ama* and *ina* are general terms of address for older persons of equal or lower rank who are not related in any specific way, as affines or agnates, to ego.

The relative age terms *aya* and *eri* can be used to address all relatives in ego's genealogical level except ego's own spouse. However, while the terms are applied to agnates and cognates simply by reference to birth order, their spouses and ego's spouse's agnates are by contrast distinguished according to the relative age status of the linking relative. Thus eBW, for example, is called *aya* even though she may in fact be younger than ego, while HyZ is *eri* even though she may be older. The usage thus accords with both the idea that spouses constitute a unity and the fact that in respect of alliance status a woman is equivalent to her husband. Co-wives address one another as *aya* or *eri* according to marriage order, even when this contradicts relative age. In contrast to *umbu* and *rambu*, *aya* and *eri* are the less formal address terms for persons in ego's generation. Indeed, of the principles of classification exhibited in the terminology I would judge the distinction of relative age to be the least subordinating in its implications. Thus while, within the clan, yB is subordinate to eB, the relation nevertheless exists within a wider context of equality and mutual support. With regard to those positions alternatively designated

with other terms, therefore, *aya* and *eri* may be described as the friendly, even affectionate, forms of address.

As noted, *umbu* and *ràmbu* are the terms required when addressing nobility. They are also employed in respectful address for strangers, unrelated persons, and others of higher or equal rank with whom ego is relatively unfamiliar. Non-relatives with whom one is familiar, on the other hand, are ordinarily addressed with the terms from ego's own line, in which case genealogical levels are distinguished either according to the person's age or following the usage of another person better known to ego who is an agnate of the addressee. Slaves are always addressed by unrelated commoners with the terms from ego's own line,¹⁹ and never as *umbu* or *ràmbu*. *Umbu* and *ràmbu*, therefore, are honorifics; thus wherever they are regularly employed as one of two alternative ways of addressing certain relatives they are always the more formal of the two possible vocative forms. Their honorific nature is of course also consistent with the use of *umbu* in reference and address for men of the second ascending genealogical level.²⁰

Umbu and *ràmbu* are used in polite speech to address all persons in descending generations. A married person, especially, should not be called *dawa*, as this would be insufficiently respectful. *Dawa* is thus mainly employed in addressing youngsters, and though it includes wife-givers, it may be characterized as a rather familiar and, perhaps, affectionate form of address.²¹ *Umbu* and *ràmbu* are the only terms of address for children and persons in the second descending generation, though these relatives and other closely related persons in descending levels may in less formal contexts be addressed by name alone.²² Another, very familiar way of addressing small children is *anakeda*, which denotes the age class of children; but this is regarded as rather brusque, and for older persons, the term is used only to summon slaves. Nevertheless, it is clear that members of lower genealogical levels may be addressed both in the most and the least formal of ways.

In male ego's genealogical level, *ràmbu* is regularly used only to address a wife. (The other modes of address for spouses were mentioned in Section 1 above.) There are no males in ego's generation whom a man should regularly address as *umbu*. In contrast, a woman will often address men in the reference category *balu* (FZS, etc.), and sometimes her husband,²³ with this term, while *ràmbu* is the polite form for FZD (w.s.), HZ, and HZHZ (*mangàlu*). This, then, provides a further indication of a woman's subordination to persons of her (prospective) husband's group. As regards HZHZ, since this relative

is for the same reason superior to HZ, then logically she too must be recognized as a superior of ego. On the other hand, it was expressly denied that female ego should address a *layia* (HZH, FZHZS, etc.) as *umbu*. This can be attributed to the fact that HZH is a wife-taker of ego's (prospective) husband, and to the special nature of the relation of HZH and WBW described in the last chapter.

The honorific *inana i tamu* (often contracted to *inai tamu* or *ina tamu*) is used alternatively to *rambu* to address married women in the category *rii ana* (SW, etc.). Since it means 'mother of namesake' (and is thus a sort of teknonym), the term is clearly an expression of the identification of alternate generations which I have elsewhere shown to be fundamental to Rindi ideology, and, specifically, of the practice whereby this woman's children will bear the names of persons in ego's generation. Several other, subsidiary address forms reflect this same principle. Thus in traditional narratives and, I was told, occasionally in the speech of elderly persons, one encounters parents addressing their children, even while they are still small, as *ama*, 'father' and *ina*, 'mother'.²⁴ In very respectful address, *ina* may also be employed for a daughter-in-law, in which instance it appears to express recognition of her position as a married woman and a (prospective) mother. But with regard to ego's own children, the use of parent terms is best comprehended in relation to two other expressions occasionally employed in respectful and affectionate address: *tamu ama* and *tamu ina*, 'namesake of father/mother'. Indeed, the Rindi explained the former usage as a short form of these latter two phrases. Although this application of *ama* and *ina* clearly constitutes a rather special mode of address, it is worth noting that were these terms a usual way of addressing children, the terminology could be said to display, as an additional principle of classification, an equivalence of positions in genealogical levels adjacent to ego's and in ego's own line.

The principle of equating alternate levels is further suggested by special address forms used for the second descending genealogical level. Thus, while they are small, grandsons in Rindi are sometimes called *umbu kudu*, 'little umbu',²⁵ and granddaughters *apu kudu*, 'little grandmother' (see also Onvlee, in Fischer 1957:16). Again, the governing idea is that members of the second descending level assume the names and, in a sense, the identities of individuals in the second ascending level from ego, and accordingly those of persons in ego's own level. In this light, then, the use of *umbu* and *rambu* to address

persons in both descending levels can be more fully appreciated. With regard to the conceptual identification of alternate generations, it is also relevant to mention the apparent derivation of *umbu* (PF, etc.), *àpu* (PM, etc.), and *umbuku* (CC, etc.) from proto-Austronesian **a(m)pu*, 'ancestor', 'grandparent', 'grandchild' (Blust 1979:206; cf. **ə(m)pu*, 'ancestor', 'grandchild', Dempwolff 1938:50), a root which Lambooy (1937:428) has suggested may further be reflected in *rambu*.²⁶ As is shown by the appearance of cognates of *umbu* that refer to grandchildren, or to both grandparents and grandchildren, in western Sumba and in other languages of the Bima-Sumba group, a terminological identification of alternate genealogical levels is common in this part of eastern Indonesia.²⁷ There is also some evidence to suggest that *àpu* is, or was once, employed in some parts of eastern Sumba as a neutral term for 'grandparent' or 'ancestor' (see Wielenga 1913:217, 220; Lambooy 1937:428),²⁸ a usage that would accord with the fact that *umbuku* is applied to both sexes. Interestingly, young children, I was told, sometimes pronounce *àpu* as *ambu* or **ampu*, and *umbu* as **umpu*, while the very similar sounds transcribed as *à* and *u* (the short 'u') are not infrequently interchanged in the speech of Rindi adults.

Persons with children are frequently addressed with teknonyms. Although it is spouses and daughters-in-law who are the most commonly addressed by this means, it is occasionally used for other persons in ego's or the first descending level, and for unrelated persons, as well. While I was variously told that the name employed should be that of the eldest of the youngest child, regardless of sex, in my experience there is no pattern to be discerned in this. Only a dead child's name may no longer be employed. In western Sumba, by contrast, it is apparently the name of the first born which is consistently used (see Wielenga 1949:84).

6. Mourning Usages

The terms used by female mourners to address a dead person represent a special modification of the general address system. The component usages are best summarized as in Table 9.²⁹

The system is distinguished from the ordinary terminology of address by a total absence of terms that specify alliance status; a lack of terms connoting inferiority (the one exception being *eri*); and a complete merging of the two ascending and two descending levels respectively.

The first two features clearly accord with the subordination of the living to the deceased and the deference they owe to him (see Chapter IX). The merging of genealogical levels, on the other hand, seems to be consistent with the transitional condition of the dead.

Table 9. *Women's Mourning Terms*

<i>genealogical level</i>	(m)	(f)
+2, +1	<i>ama</i>	<i>ina</i>
0	<i>umbu</i> <i>aya/eri</i>	<i>rambu</i> (EGO) <i>aya/eri</i>
-2, -1	<i>umbu</i>	<i>rambu</i>

Thus, as noted, in the context of the funeral the terms for members of the second ascending level (*umbu* and *apu*) refer to the forbears who come to collect the soul. By contrast, the newly deceased person has yet to be incorporated into the afterworld, and like a child is dependent upon and subordinate to his forbears; so it would be inappropriate to call the two classes of the dead by the same terms.³⁰ It is worth briefly comparing this system to the Penan mourning usage described by Needham (1954:263-67), whereby the surviving parents and children of a dead person call one another grandparents and grandchildren. In Rindi, however, it is rather that parents address grandchildren as children (which they do also in ordinary address) while children address grandparents as parents; and in this case the addressee is the dead person himself, not his surviving relatives.

7. *Comparative Remarks on Reference and Address*

The terms of reference and address can now be compared with regard to the principles of classification noted above. One major difference between the two systems is that in address the distinction of alliance status is less consistently exhibited than is sex. Thus, whereas 14 of the 19 male and 15 of the 20 female reference terms specify alliance categories, only 4 of the 12 male and female address terms do so.

(The numbers of terms that specify sex in reference and address, on the other hand, do not vary significantly.) This difference I would ascribe to a reluctance to employ in face to face interaction terms which express the hierarchical aspect of the alliance relation, a situation that agrees with the absence of a pronounced pattern of deference towards wife-givers in everyday life. Indeed, this seems to apply in a more general way to the address system, since only four terms — *kiya*, *mamu*, *eri*, and *dawa* — indicate by one or another criterion ego's superiority to the addressee. Even then *kiya* and *mamu* are superior in terms of genealogical level, while *dawa* are alternatively called *umbu* or *rambu*.

The distinction of relative age, as expressed by *eri* and *aya*, on the other hand, has much less a connotation of subordination than do the other principles; and this accords with the fact that it is mostly the extensive application of these terms that accounts for the relegation of alliance as a principle of classification in the address terminology. Otherwise alliance categories are replaced in address by terms that specify sex. I suggest, therefore, the following ranking of the four principles according to the extent to which they connote subordination: (1) alliance, (2) genealogical level, (3) sex, and (4) relative age.

As regards the number of terms that distinguish relative age, as opposed to their range of application, however, this factor still ranks below alliance as a principle of classification in address. Thus the order of the various principles in respect of the extent to which they are expressed in the address terminology is: (1) genealogical level, (2) sex, (3) alliance, and (4) relative age. With the reference terminology, by contrast, the relative positions of (2) and (3) are inverted, while (4) is not exhibited at all.

Despite the use of *umbu* and *rambu* to address persons in more than one level, then, genealogical level is still the distinction most consistently applied in both reference and address. This clearly accords with the importance the identification of alternate generations and the opposition of adjacent generations assume in Rindi ideology. What is perhaps most significantly absent from Rindi terminology, therefore, are equations between adjacent levels in a single line. The fact that genealogical levels are distinguished slightly more often than alliance status among the reference terms, however, can largely be attributed to the absence of the latter distinction from terms used by members of alternate generations. This, of course, is consistent with the fact that the relationship of such persons is represented as one of identity,

and, particularly, that personal names are taken from those of members of the second ascending level belonging to either the father's or the mother's (i.e., a wife-giving) group.³¹ There is thus some justification for ignoring the second ascending and descending genealogical levels altogether in assessing the consistency with which the various principles are exhibited. If only the three medial levels of the men's reference terminology are considered, therefore, among the 16 terms genealogical level is distinguished in 15 and alliance in 14 cases; so the two principles appear about equal.³² If the same procedure is adopted for the address terminology, however, there is still a marked disparity between them; but, in accordance with what was said just above, this is consistent with the distinction of genealogical level being less subordinating in its connotations than the distinction of alliance status.

CHAPTER XV

MARRIAGE

The eastern Sumbanese words for 'to marry' or 'to be married', for a man and a woman respectively, are *lalei* and *mangoma*; and the phrases *lii lalei*, *lii mangoma* (*lii*, 'way, matter, etc.')

 designate the entirety of rules, institutions, and procedures involved in legal marriage.¹ Cohabitation, whether within or outside marriage, on the other hand, is called *kanoma*, 'to look after', also meaning 'to prepare, make ready'.² But whereas *kanoma* can thus refer to the more substantial aspects of the relation of man and wife, properly speaking only *lalei* and *mangoma* imply a recognized, legitimate union that constitutes an alliance. Conversely, I heard of several cases where a marriage had been legally contracted but the spouses had not subsequently cohabited or even consummated the union; but this does not detract from the alliance. In this way, then, the Rindi are able to distinguish legal marriage from informal unions which have not been legitimized; and whenever I use the term 'marriage' it is to the former that I refer.

The topic of marriage (or alliance) prestations forms the subject of Chapter XVII, while the various ways of contracting a marriage are described in Chapter XVIII. Here, then, I shall mainly be concerned with the concomitant institutions of marriage in Rindi. It is appropriate, however, first to outline the rules and other factors which govern the selection of a spouse. The extent to which Rindi marriages conform to these rules is considered in Chapter XIX.

1. Rules

Marriage in Rindi is governed by several rules of differing status. First, with regard to relations between descent groups, it is prescribed that the transfer of women in marriage be unilateral. It is also said that a wife should be taken from an established wife-giver and, especially, from the clan of the mother's brother. But this is not

insisted upon in every case; and provided a marriage with an unrelated group does not disrupt existing ties of alliance in general,³ and established relations with one's own group are otherwise perpetuated, the Rindi maintain a neutral attitude towards unions of this sort. A new alliance is called a 'newly cleared path, newly risen hill' (*ànda hili* [or *bidi*] *lota*, *palindi hili* [or *bidi*] *hura*).⁴ The phrases also refer to an additional increment of bridewealth (minimally one horse and two metal pendants) which the new wife-giver can then demand. After the initial marriage, the social classification is of course adjusted to accommodate the new relation.

Before a wife is taken from other than the mother's natal clan, the mother's brother should be informed and his agreement secured, though it was said that so long as other marriages maintain the alliance, he would not usually object. There is no mandatory fine payable if a woman of this group is not married; and a man cannot force his ZS to marry his daughter. Nevertheless, I did hear of a traditional procedure, called 'to draw water from another spring, to gather wood from another forest' (*taku wai hau mata, ohu ai hau omangu*), whereby one might formally approach a long established wife-giver to secure, by way of an exchange of prestations, his approval for such a marriage. If the wife-giver does not wish to give his consent, I was told, he may then alternatively offer his daughter in marriage with a relatively low bridewealth. The procedure seems only to be followed, however, when the wife-taker is particularly concerned not to endanger an alliance of long standing and was said not to be necessary in the case of 'new affines' (*bidi kalembi*).

With regard to category, on the other hand, marriage is prescribed with a *balu* (MBD, etc., m.s.; FZS, etc., w.s.). There is, however, no standard idiom in which the rule is formulated, and the prescribed category of wife is in fact more commonly specified as the daughter of a *tuya* (MB, etc.).⁵ Sometimes the Rindi also say a man should marry an *ana polangia*, i.e., a closely related *balu* from the mother's natal clan and, in particular, the genealogical MBD. But this expresses a preference concerning relations between lineal groups rather than a categorical prescription, and marriage with other women classified as *balu*, whether or not they derive from the mother's brother's group, is equally in accordance with the rules.

The most preferred type of marriage in Rindi is thus that between genealogical MBD and FZS. Indeed, the extent to which they favour marriage with the MBD (and, arguably, the incidence of such unions;

see Chapter XIX) suggests that 'preference' does not adequately describe it; and that it is perhaps more accurately characterized as a rule enjoining that if a MBD is available to a man, he ought to marry her. Before all other women of the mother's clan, therefore, the genealogical MBD is designated as a man's *tanggu*, 'rightful share, portion'. Since it is held that elder siblings should marry before younger ones, where there are several women of the preferred genealogical type, the most appropriate spouse is the eldest available daughter of the mother's eldest brother.⁶

In the more general view, the closer the genealogical relationship between a man and a *balu*, the more preferred she will be as a marriage partner. However, given the strong preference for marriage with the genealogical MBD, it is evident that if the closest available woman is a distant relative, a man's chances of marrying her are reduced, since it is then more likely that she will be taken by another person, from among ego's agnates or another of her father's wife-takers, who has a stronger claim to her. It sometimes happens, though, that a wife-giver with relatively few women available, in order to maintain various alliances, will divide a group of sisters among several different wife-taking clans.⁷ As I have previously shown, differences in (formal or informal) class standing within a descent group are another factor which contribute to the preference for marriage with a woman from the mother's brother's clan, and with the genealogical MBD in particular, and, at the same time, limit the possibility of marriage with other women who, with regard to both existing alliances and category, would otherwise be eligible as spouses.

In some societies that practise asymmetric alliance, the preference for marriage with a MBD or another woman of her group applies only to the eldest of several brothers; but I found no rule of this sort in Rindi. While it is judged sufficient to maintain an alliance if just one of a set of brothers marries someone from the mother's natal clan, therefore, the others are not thereby precluded from taking wives, including a MBD, from this group, though for the reasons mentioned above, statistically speaking, younger brothers will have less chance of doing so than older ones. A similar rule in some societies (e.g., the Karo, Singarimbun 1975:154) is the prohibition of marriage with the BWZ. The marriage of two full brothers to two full sisters, however, is not uncommon in Rindi, and I never heard that it was in any way undesirable.⁸

While women other than *balu* are ordinarily prohibited as spouses,

it is also permitted in Rindi to marry a female *dawa* (WBD, MBSD, etc., i.e., a *dawa* on the wife-giving side) provided there is no one in the first descending genealogical level from ego eligible to take her as a wife. This seems, then, to be what Lévi-Strauss (1969:120) has described as a 'privileged union'. A *dawa* is especially suitable as a spouse when the mother's group has no *balu* available; and a woman in this category makes a good second wife when the first is elderly and requires help in domestic tasks. Polygynous unions involving a *dawa* thus have a regular incidence in Rindi. A woman who marries a *kiya* (FZH, etc.) is said to 'hang onto the tail of her *mamu*'s (FZ, etc.) skirt' (*kanderungu kiku laü mamu*), as she follows her FZ in marriage. Since the woman is from a wife-giving clan, such a marriage does not in any way alter the existing alliance but, on the contrary, reinforces it. In this regard, it is also worth pointing out that in several other societies that practise asymmetric alliance (e.g., Purum, Needham 1962:77; Kédang, Barnes 1974:266; Wailolong [East Flores], Barnes 1978:146) WBD and MBSD are included with MBD in the prescribed category of women.

The prohibition of marriage with women in the category *anawini* (Z, FBD, MZD, FZD, FFZDD, etc.) is most strictly enforced in respect of members of ego's own clan and those of his immediate wife-takers. The closer the genealogical relation of a woman in this category, moreover, the more firmly do the Rindi disapprove of the marriage; thus among patrilineal relatives the genealogical FZD is especially proscribed. I was also told, however, that FZDZH (or FFZDD, ZHZHZ) as well, should not be married, and that a union of this sort was equivalent to marriage with FBD or FZD. As I shall later elaborate, this is consistent with the dislike the Rindi express of alliance cycles, and the part played by the bride's mother's brother at her marriage. I found no cases of marriage with these genealogical relatives in Rindi.

Although the Rindi say marriage should not take place between the children and descendants of female agnates married into different clans, only in the case of genealogical MZC, and possibly the children of other closely related women (e.g., MFBDS and MFBDD), does this seem to be insisted upon. Thus where the mothers and grandmothers of the descendants of two sisters derived from other (wife-giving) clans, marriage is usually allowed. Nevertheless, the fact that the female forbears of two lineages were siblings was used in one case I encountered to argue against one group taking a wife from the

other. As noted, lineages that have taken wives from the same other group classify one another as 'brothers', *angu paluhu*, which in this context may be glossed as 'co-affines'. This fact appears also to have some bearing on the previously noted disapproval of marriage with a woman from the group of wife-givers of one's own wife-givers, i.e., a *yera kawini*, since by this arrangement ego and his own wife-givers implicitly come to be related in the same way as the children of sisters. It should be stressed, however, that this attitude mainly concerns marriage with the specific line from which ego's own MB and MBS regularly take wives. Thus, with regard to entire clans, a group may contract marriages with more distant agnates of the MBWB; and alliances with clans that give wives to another wife-giver are by no means uncommon in Rindi. As mentioned earlier, moreover, even marriage with the closest wife-givers of one's own wife-givers is permitted when the latter cannot provide a spouse. The union is then described as *tu pingi*, 'to place, use the trunk' (i.e., the wife-giver's wife-giver), or with the phrases *kapola wihi anana*, *hàmu wihi inana*, 'the child's (i.e., the own wife-giver's) legs are covered in sores, (but) the mother's (i.e., their wife-giver's) legs are fine'. In this situation, the woman might be taken directly, or a procedure known as *anangu banda*, 'to have, use animals in the place of children', whereby the wife-giver obtains a woman from his own wife-giver with a payment of bridewealth, might be adopted.⁹ When the latter arrangement is followed, the payment may be provided entirely by the wife-giver or partly by the wife-taker (see Onvlee 1973:101). But in either case the bride is considered to be taken from the wife-giver and not from her natal group; so the original alliance is perpetuated.

When the wife-giver cannot provide a *balu*, it is also possible, by way of *anangu banda*, to marry a classificatory 'mother' (*tambaru paina*), though informants stressed that the woman must be a distant relative and that the union should be ritually cooled. While I am not sure how distant the relationship need be, certainly a genealogical MZ and probably MFBD would be ineligible. Marriage with women in this category from another wife-giving clan (that of the FBW or father's second wife, for example), however, seems to be somewhat less problematic. Unions with distantly related women classifiable as *àpu* (PM) or *umbuku* (CD) from wife-giving clans appear usually to be possible. In this case, as to some extent with other women who can be reckoned to belong to normally prohibited categories, the marriage is treated as one that involves a previously unrelated woman.

This situation underlines the point touched upon in the last chapter, that the categories of relationship reflect not so much genealogical ties as prevailing patterns of alliance, and so to a degree can be altered to accord with changes in these. Stated otherwise, where a woman can be reckoned to be related in one way genealogically, and in another by virtue of alliance, greater emphasis tends to be placed on the latter.

2. *The Arrangement of Marriages*

The Rindi regard marriages contracted for economic advantage or because of physical attraction, which thus do not take proper account of existing alliances, as undesirable and likely to fail. Although a wife-taker may be poor, it is said, one should yet provide him with wives: 'one should not be tempted by people with golden valuables and tall horses' (*ambu itaya na marara bandana, na majangga njarana*). Marrying for the wrong reasons, or contracting marriages in an irregular manner, is also thought to entail the risk of becoming involved with witches. Either the new wife-givers or the new wife-takers might turn out to be witches.

Unless a severe disability (e.g., insanity) absolutely prevents it, everyone in Rindi is expected to marry. Prolonged or permanent spinsterhood, however, is rather more tolerated than is bachelorhood; and there were more mature spinsters than mature bachelors in Rindi. Spinsters are (relatively) most numerous among noblewomen, who were often said not to have married because a man of the appropriate rank and alliance status could not be found. Although poverty is sometimes a factor, e.g., with orphans, this seems not always to account for some men never taking a wife; and in two of the instances with which I was most familiar, the main reason seemed to be simply that the men had no desire to do so. Bachelorhood certainly often leads to impoverishment, however.

As young people in general are considered too immature and too much influenced by romantic and other extraneous factors to select a spouse for themselves, marriages arranged by parents are the norm in Rindi. A person is thus expected to comply with his parents' wishes, especially when the marriage proposed for him is with an established affine. In the case of a daughter of a friend of mine, who attempted to elope with a lover shortly after her parents had arranged to marry her to her FZS, the girl's actions, in respect of the threat they posed

to this long standing affinal connexion, were publicly decried as a 'source of disorder (literally, 'dirtiness')' (*pamarihaku wàngu*), and 'something that threatened extinction' (*pambuta wàngu*). We are thus reminded of the vital nature of the alliance tie. Of course, the wishes of parents and children do not always conflict. Not only will young people know who is and who is not an eligible spouse, but from an early age the parents will encourage their attentions towards persons of the appropriate category. It is the parents, however, who should have the final say.

Sometimes children are betrothed in infancy, by way of an exchange of alliance prestations known as *tiwalungu wiri bara, ru karaki*, 'to hang up a white sign of prohibition, a forbidding leaf'.¹⁰ The phrases, I was told, also refer to a string of beads tied to the girl's right wrist to show she is spoken for. If this is done, it is not necessary formally to request the bride and thus to make a further prestation when she reaches marriageable age. Should the woman later be taken by another group (e.g., by way of elopement), then the wife-taker must be compensated by the interloper for all the goods previously given to the woman's group, a practice known as 'replacing the goods, exchanging the horses' (*hilu banda, njepa njara*).

Though occasionally the young groom himself first raises the question of his marriage, the initiative lies with his parents. They must then communicate their intentions to other clan members and secure their agreement before a proposal is formally made to the bride's group. The groom's mother, too, should agree to the union, and on the wife-giving side the agreement of the bride's mother's brothers as well as her own agnates must be obtained. Parents of a reluctant bride may attempt to induce her to accept a proposed marriage by offering her gifts: decorated textiles, beads, and arm-bands, i.e., articles of the sort used as counter-prestation. Forced marriages do occur (see Chapter XVIII, Section 5), and physical coercion is sometimes employed to prevent a woman from eloping. Thus, in the case mentioned just above, after the girl's initial attempt to elope she was detained in the house, where her feet were placed in wooden stocks (*tangga*). Though this measure was perhaps somewhat extreme, it was widely recognized as appropriate in the circumstances; and she was released only after the police intervened. It was also suggested that the girl quickly and forcibly be married to her FZS, but this was never done. At the same time, however, the Rindi appreciate that marriages contracted against the wishes of one of

the spouses are likely to prove unsatisfactory and, in particular, to result in separation. Similarly, with elopement the parents often later acquiesce in view of the young couple's evident determination to marry. Indeed, the eastern Sumbanese display a general reluctance to intervene in matters where strong emotions are involved; and the forcible separation of lovers is claimed to be a common cause of suicide. Nowadays, moreover, to contest an elopement usually requires the intervention of government and legal authorities, and this can involve a protracted and sometimes costly procedure, the outcome of which is often less than satisfactory for the woman's group.

Unions that go against the wishes of parents, therefore, occur with some regularity in Rindi. These are called *patidungu*, 'to place, carry (something) on the head', which in this context, I was told, may be glossed to 'to do something which one has been told not to do'. The term seems also to suggest the idea of taking a burden upon oneself. While not all unions counted as *patidungu* involve categorically prohibited spouses, informants stated that marriages which do can be initiated only in this way. If the woman's group subsequently refuse to go along with the match, then no bridewealth is exchanged; so it is never legitimized. In one case I know of, the father of a girl who had run away to live with a lover swore never again to have contact with her and, on the threat of their separation, he forbade her mother to do so as well. The girl, he said, would be regarded as stillborn and no reconciliation would be possible, even if she later left the man. Though this attitude seems not to be unusual, some people thought it rather extreme, claiming that in the same situation they would be inclined to acquiesce and accept a bridewealth. This is indeed possible, provided of course that the spouses do not belong to strictly forbidden categories (e.g., MBS and FZD) or to different social classes. But when there is no reconciliation, a *patidungu* union cannot be considered a legal marriage, and it does not constitute an alliance.

Despite the concern that their children marry correctly, parents in Rindi are not particularly cautious about premarital attachments of young people. An exception to this is the nobility, who are especially concerned that their daughters do not become involved with men of lower rank (see Kruyt 1922:506-7). While it is sometimes viewed with disdain and recognized to entail certain risks, therefore, Rindi parents grudgingly accept premarital sex as inevitable.¹¹ Young couples meet privately, usually outside the village in the evening — the river's

edge being a favourite rendezvous — though occasionally a young man will surreptitiously enter a girl's sleeping compartment and spend the night with her there. Whether the parents intervene once they know of such an affair depends upon whether they would object to the prospect of a marriage.¹² If they would, a dispute might arise with the girl's family appearing as the offended party. So long as the relationship is not incestuous or adulterous, however, all is normally resolved once they are satisfied that the attachment is effectively broken. I never heard that virginity was valued in a wife; it is certainly not expected.

Illegitimacy is not uncommon, particularly among the lower classes, in Rindi. Premarital pregnancy, therefore, does not always lead to marriage, though there were a few cases where it apparently had done. Especially among the nobility, I was told, unmarried pregnant women may undergo abortion, but I do not know how often this recourse is tried. The low regard in which illegitimacy is generally held in Rindi is suggested by the phrases *ana njuraku*, 'child of an illicit affair' (see Chapter XVI), and *anakeda la wuku rumba*, 'child from the thick of the grass', both of which refer to a bastard.¹³ The second phrase indicates that the infant as it were springs from the wild (see *rumba*, 'grass, weeds', as a metonymic reference to the wild), and hence that it is conceived outside the bounds of social order. This idea is further expressed in the reference to an unmarried mother as someone 'already gored by a (wild) pig, torn by a monkey' (*mbàda kainanya wei, hirananya buti*). While some men consider marrying such a woman to be a slight to a man's honour and virility, others see it as advantageous, since one would then also obtain the rights to her children.

3. Polygyny

There is no formal limit to the number of women a man may marry in Rindi, and the same rules govern the marriage of a second wife as that of a first. Apart from demography, the incidence of polygyny is restricted mainly by economic factors. The first wife, however, must give her consent before a second is taken; and on several occasions this was mentioned as the reason a man had not taken another wife. The requirement also applies to the inheritance of widows, insofar as a sexual relationship is contemplated.

Of a total of 1,324 men listed in Rindi genealogies, 307 or

23.2 per cent had more than one wife. Of these, 75.2 per cent (231) had just two, 17.6 per cent (54) had three, and 7.2 per cent (22) had four or more wives. The highest number I recorded, in the case of a forbear of the noble clan, was eight. Since some of the men were long dead, however, it was not possible in all of these cases to tell whether the wives were living at the same time.¹⁴ Among noblemen, the incidence of polygyny is about twice as high as among other classes: thus 42.3 per cent of the 52 noblemen recorded in the genealogies had more than one wife, whereas among commoners and slaves the proportion was 22.6 per cent (of 1,272 men). Information concerning the relationship between two or more of the co-wives in 291 plural marriages is set out in Table 10.¹⁵

Table 10. *Relationship of Co-wives in Polygynous Unions*

	Number	Percentage
Full or half sisters	41	14.1
Classificatory sisters	6	2.1
Full or classificatory <i>mamu</i> (FZ) and <i>dawa</i> (BD)	5	1.7
More distantly related agnates	37	12.7
Total: same clan	89	30.6
Members of different clans	202	69.4
TOTAL	291	100.0

The number of plural unions involving full or half sisters calls into question Kruyt's (1922:494) statement that such marriages are uncommon on Sumba and that a woman will not usually allow her husband to take her sister as a second wife.¹⁶ It is however forbidden to marry twin sisters, since then the 'life force(s)' (*ndewa*) of the two women would conflict, and one would die. Accordingly, while two brothers may marry twin sisters, after one of the men dies the other may not inherit his widow. By contrast, there seems to be no problem in a widow being inherited by her deceased husband's twin brother.

One motive for taking a second wife is to provide the first with domestic help. But this applies more to the lower classes than to the nobility, since the latter have slaves to carry out such labours. Older men of lower rank, on the other hand, often take a young second wife for just this reason.¹⁷ Among the higher classes, moreover, co-wives are often housed in different villages, one typically remaining

in the clan's principal settlement while the others live in subsidiary hamlets close to the husband's fields and pastures.

Childlessness, both absolute and relative, is another reason for plural marriage. Thus, in the 307 polygynous unions, nearly one quarter of the first wives and about the same proportion of second wives were without children.¹⁸ If we add to these the number of wives with only female children, the figures become appreciably higher. Among the plural marriages contracted by noblemen, one half of the first wives and 54.5 per cent of second wives were either absolutely childless or without male offspring. The figures thus appear quite high, although it should be recalled that the eastern Sumbanese birth rate in general is very low. Conceivably, the advantages of maintaining alliances with several different clans simultaneously is also an incentive to polygyny, as Leach (1961:84) reports of Kachin chiefs (for Sumba, see also van Dijk 1939b:195). Yet when it is recalled that in over 30 per cent of plural marriages two or more of the wives were from the same clan and nearly half of these were sisters, it seems this factor may be somewhat less significant in Rindi than in similar societies elsewhere.

Relations among co-wives are normally governed by marriage order. Thus when the women live together, it is usually the senior wife who heads the household, though I was told that when the highest ranking wife, often the man's preferred spouse (e.g., his MBD), is not the first to be married it is nevertheless she who is considered the chief wife. In my experience, however, relations between co-wives are normally amicable and do not show any marked pattern of deference or subordination. A man's obligations to his various wives and to their natal groups is in each instance fundamentally the same, and is not affected by the order in which the marriages were contracted.

4. Widow-Inheritance

A man's agnates are obliged to maintain his widow, and it is expected, when she is still fairly young, that one of them will take her as an inherited wife. Normally the inheritor, who need pay no additional increment of bridewealth for the woman, is the dead man's eldest surviving brother or else another of his brothers or close agnates of the same rank as he.¹⁹ But in any case, the person must be of the same genealogical level as the deceased or, failing this, a distantly related individual of the second ascending or second descending genealogical level.²⁰ It cannot be anyone the dead man called 'father'

(*ama*) or 'child' (*ana*). The rules reflect once more, then, the principle of the equivalence of alternate generations found elsewhere in Rindi ideology. The widow herself has a say in whether she remarries or not. If her children are old enough to provide for her, it is not necessary that she do so. When at least part of the bridewealth has been discharged, however, she is obliged to remain with her deceased husband's clan. As a mark of respect, I was told, a woman should wait a year or two after her husband's death before remarrying; otherwise it might be said that she did not care for him.

Although she is spoken of as his wife, a widow is not fully considered the spouse of the man who inherits her.²¹ He does not 'marry' (*lalei wàngu*) her but rather 'looks after' (*kanoma*) her. Thus, if the second husband is buried in a separate grave from the first, the widow should be buried with her original husband. Nevertheless, any children the man has by the widow are legally his own, and my suggestion that they might yet be considered the issue of the dead man was greeted with amusement. On the other hand, if the bridewealth for the woman is not paid or fully discharged before her husband's death, it rests principally on this man to complete it, and by so doing the deceased's wife and children come to be considered his own (see Kruyt 1922:505).

Kruyt (1922:505) states that if a deceased man's agnates are unwilling to complete the outstanding bridewealth, the widow's natal clan can reclaim her and her children and marry her to another party. The Rindi, however, claimed this would be possible only if no bridewealth at all had been given for the widow, which accords with the rule they articulate that bridewealth may not be received twice, i.e., from two different groups, for the same woman. Evidently, then, the point is that the deceased's agnates should make good the debt. If they are unable to pay, the debt is inherited by the woman's children (see Kruyt *ibid.*).

Though the Rindi insisted that it was a breach of custom, there were nevertheless several cases where a widow, after her husband's death, had returned to her parents and subsequently entered into an informal union (*patidungu*) with a man of another clan. A man who thus takes another clan's widow is said 'to rest (his head) on a worn-out pillow, to lie on a faded mat' (*nulangu mbora nulangu, napungu mbora topu*). To resolve the matter, he must make a payment of horses and metal valuables to the dead husband's group. This, however, is not called bridewealth but is spoken of as a funerary prestation

(*dàngangu, ihi ngaru*); thus he does not actually marry the woman. Two alternative procedures were described to me in Rindi. The first, a more traditional practice said no longer to be feasible, is called 'to enter with the foundation of one's house' (*tama dāngu watu umana*) and requires that the man formally become a clan brother (*angu paluhu*) of the dead man. Thus, he must thereafter contribute to corporate clan affairs as would an agnate, and any children he may have by the widow are considered members of the dead husband's clan. The other arrangement, which entails a higher payment, is called 'to enter with half (the body)' (*tama dāngu hapapana*). The new husband then holds fewer obligations towards the clan of the deceased and can consider children he has by the widow his own, though her first husband's agnates still have a claim to a share of bridewealth received for his daughters. In both instances, therefore, the anomaly of a woman being consecutively the wife of men of different clans is rationalized by redefining, in some degree, the clan affiliation of the second husband. This, then, underlines the principle that a woman once legally married cannot later be formally transferred to another clan.

5. Divorce and Separation

Before discussing the possibility of divorce in Rindi, it is necessary to distinguish it from separation, which by contrast to divorce does not, in itself, entail a legal dissolution of the marriage contract or the alliance between the two clans. Separation, which has a regular incidence in Rindi, is called *wārungu*, 'to discard', 'to lose something', 'to leave behind, abandon, desert', and 'to forget, neglect'. The action can refer to either spouse.

Separation normally follows a serious breach — and usually a major row — between spouses. I never heard of separation by mutual consent. The most frequent cause was said to be the wife's adultery,²² which accords with my own impression, though other failings of the woman as a wife or mother were mentioned as well. A wife might reasonably leave her husband, I was told, if he fails to provide adequately for the family, for physical maltreatment, taking another wife without her consent, falsely accusing her in public, or if he should commit adultery. These grounds reflect the recognized rights of a Rindi wife.

Whoever is judged culpable, however, it is normally the wife who

leaves her husband, by returning to her parents. A speaker must then be sent to the wife's father to ascertain that she is there, discuss the reasons for her leaving, and request his assistance in reconciling the couple. When agreement is reached, the speaker, with other members of the husband's group (though not the man himself), returns to collect the woman. On this occasion an exchange of alliance prestations is required,²³ and the wife's father slaughters a pig. Should the matter prove more serious (particularly, it seems, when the husband is judged to be the one in error), higher prestations may be demanded and both parties must slaughter pigs. The woman's father then also gives his daughter two cloths, in order to induce her to return to her husband.

Sometimes, because the husband's clan does not attempt to recover the woman or she proves to be unreconcilable, a couple remain permanently separated. But even in this situation, I was told, it is not usual for the husband to request the return of the bridewealth given for the wife; nor would the wife-giver normally agree to this. The alliance between the two groups is thus not affected; and as I myself have witnessed, each continues to act towards the other in the way expected of affines (at one another's funerals, for example). An estranged wife, moreover, should be buried with her husband. In other words, she remains his legal wife.

However, I did hear of circumstances in which it would be possible to reclaim the bridewealth, namely when the estranged wife is subsequently married to another man, or when a man 'steals' (*wahi*) the wife of another. In the second case it is the offender who should make good the bridewealth, and it seems likely he would also be required to pay a fine, as Kruyt (1922:509) states. Both the bridewealth and counter-prestation goods are then simply returned, the transaction being accomplished without ceremony. Yet I was also told that by reclaiming bridewealth, the husband's group forfeit all rights to the woman's children, while according to another opinion, if the couple have children the prestation cannot be returned. It is probably for this reason that while there were several cases in Rindi where estranged wives had remarried, or at any rate begun to cohabit with, men of other clans, I never heard of one instance in which the bridewealth had actually been returned. Although the legal dissolution of a marriage is apparently possible in this society, therefore, it seems rarely to occur.²⁴

Rindi marriages practices thus very closely approximate the complex

of institutions which Needham (1970:257) suggests are 'significantly coherent' in the context of prescriptive alliance: '...arranged marriages, corporate involvement of descent groups in marriage payments, widow-inheritance, sororal polygyny, and absence of divorce'. The question of descent group corporateness with regard to marriage was discussed in Chapter XII. Divorce with the return of bridewealth, though formally possible, is unusual and infrequent in Rindi; and the fact that it does not follow automatically from the estrangement of spouses is consistent with the distinction between individual marriage and group alliance that is fundamental to this sort of system. The other three institutions — arranged marriage, widow-inheritance, and sororal polygyny — are straightforwardly characteristic of Rindi. The exchange of masculine and feminine prestations when a marriage is contracted, which Needham (1970:259) also mentions as typical of asymmetric alliance, is similarly well attested, as I shall further illustrate in Chapter XVII.

6. *Incorporation*

It is the general rule in Rindi that a woman and her children, whether or not the latter were born in wedlock, belong to the clan that has paid (or contracted to pay) bridewealth for her.²⁵ There are thus two categories of persons who do not belong to their fathers' clans. One is the offspring of an unwed mother, who, so long as she remains (legally) unmarried, are counted as members of her natal clan. The other case concerns the children of a man who, on the agreement of both parties, marries a woman without paying bridewealth and himself thereby becomes affiliated to the wife's group. This institution is known as *lalei tama*, 'to marry (and) enter', or 'to marry into (a clan)'. Although it may be occasioned by poverty, as I illustrate just below this is not the only reason such an arrangement may be resorted to.

Regarding the way bridewealth crucially affects a woman's incorporation, I was told that it is always preferable that a man's own father (or elder brother, where an inheritance has yet to be divided), rather than a more distant agnate, provide the principal portion of the prestation, since in the latter case the other party could claim rights to his children. Sometimes, though, this is done deliberately, as, for example, when a nobleman without heirs requires a classificatory brother's son to succeed him.²⁶

The offspring of unions which, though not recognized by the

mother's group, are nevertheless of a permanent nature (i.e., *patidungu* unions), are ordinarily considered to belong to their fathers' clans. After one of the spouses dies, or if they should separate, however, the mother's clan can claim one half of the children as members. The practice is called 'fee for the stallion, replacement of the sow' (*kahewa njara mini, hilu bai wei*), which phrases indicate that the children who go to the mother's group are regarded as compensation for the unpaid bridewealth while the father's clan retains the others in recognition of his having raised and provided for them, and, possibly, of their biological paternity. Occasionally a woman who has thus been informally married is later legally married to someone else. Where there are children by the first union, it is then the woman's legal husband who can claim rights to them. However, since the Rindi seem also to regard biological paternity as significant, the situation of such children is often somewhat equivocal; and in cases I encountered they were ordinarily spoken of as members of their genitor's clans. In one instance, moreover, a dispute concerning the affiliation of a boy born of an informal union had been settled by the former government raja of Rindi in favour of his biological father, although his mother, shortly before her early death, had legally been given in marriage to someone of another clan. The headman of the clan from which the boy later took a wife, however, still insisted to me that he belonged to his mother's legal husband's clan, even though it was the young man's biological father who had paid the bridewealth for his wife.

In circumstances such as these, it appears that biological paternity is taken into account also in selecting the child's spouse. Thus one man, whose legal father belonged to the clan Katinahu but whose genitor was a Tidahu man, married his genitor's MBSD from the clan Matalu, the principal wife-giver of Tidahu. While formally he belongs to Katinahu, which clan paid the bridewealth for his wife, therefore, for the purpose of marriage he was evidently counted as Tidahu, the more so since Matalu is actually a wife-taker of Katinahu. In fact, when giving me their genealogy, Matalu first identified him to me as a Tidahu man, though on later questioning they claimed to have been mistaken in this. It seems, then, that biological paternity is not entirely ignored in favour of legal paternity in Rindi. The point to be appreciated, however, is that for the Rindi, the two should coincide, so that where they do not a child's identity is always in some degree ambiguous.

Legitimate children cannot be adopted into other clans, and orphans are provided for by their father's agnates. Children with parents still living, though, may be fostered (*radangu*, 'to raise, bring up') by (relatively) childless persons who would benefit from their labour.²⁷ Foster children (*ana radangu* or *ana payila*; *payila* is 'led' or 'pulled [away]')²⁸ are normally obtained from clan mates, but failing this it is also possible to approach affines, including married daughters. In the latter case, the child's clan affiliation does not change, though a man may inherit from foster parents who have no children of their own.²⁹ When a foster child's own father is still alive, I was told, it is he who is responsible for the principal marriage payments. If he is an agnate, however, the foster father is expected to contribute to the wider exchange of prestations. Sometimes a boy will go to live with his MB on the understanding that, should his work prove satisfactory, he may later marry the man's daughter with a reduced bridewealth; and by a similar arrangement, a couple may foster a young WBD, who will eventually be married to their son (see Chapter XVIII, Section 4).

As noted just above, in certain circumstances a man's clan affiliation can change upon his marriage. In each instance, this follows from the fact that, on the agreement of the parties involved, bridewealth is not paid for his wife by, or on behalf of, his own clan. One circumstance in which such marriages occur is when a man without sons invites one of his sister's sons to succeed him and hence perpetuate his lineage by marrying his daughter. Should the mother's brother be childless, he may then obtain a wife for the sister's son by way of *anangu banda* (see Section 1 above). A similar procedure, followed when a noble lineage dies out,³⁰ is that called 'to make the moon rise, to make the fire flame' (*pahunga wulangu, paroka epi*).³¹ A man from the extinct line's wife-takers or, if this is not possible, another person of the appropriate class standing, replaces the extinct group and inherits their property: he goes, as they say, 'to guard the house, to attend the graves' (*dai uma, tutu reti*), an idiom which refers to succession in general.³² With the inheritance he then marries a woman from the extinct lineage's wife-givers or, if such a woman of child-bearing age is available, a widow of the extinct group.³³ The children of the marriage may either all be counted as members of the extinct group or divided equally between this group and their father's natal clan (thus in the same way as the offspring of a *patidungu* union that has been dissolved).

When a lineage is thus brought back into existence by a wife-taker, their marital alliance cannot continue owing to the man's agnatic tie to his natal clan. I was told, however, that it may be resumed in the generation of his great-grandchildren, or, as this was also expressed, after four generations. The appearance of four in this context calls to mind several similar rules that concern marriage, e.g., that whereby a lineage may rise in class standing by consistently marrying women of a higher rank during four generations (see Chapter X). As with the temporal arrangement of component rites of life cycle ceremonies (see Chapter IX, Section 11), then, in these cases the number appears to define a period of time necessary to complete a radical change of status.

7. *Marriage among Slaves*

While, in respect of category, members of the slave (*ata*) class in Rindi are bound by the same rules of marriage as the rest of the population, they are not required to marry outside the clans to which they are attached. As regards institutions of marriage and incorporation, therefore, their position is obviously different from that of the higher classes and so requires separate comment.

As noted, with certain slaves, in particular the *ata memangu* belonging to the nobility, it is preferred that they take wives from within the clan. This is reflected in Table 11 (Section (a)), which concerns unions of 395 *ata* men and 243 *ata* women in Rindi. The extent to which the preference is followed, however, is more clearly shown when one considers only the marriages of male slaves attached to the noble clan, which constituted just over 90 per cent of the total of male slave marriages. In this case, moreover, nearly 40 per cent of marriages outside the clan involved *ata ngàndi*, slave women who accompany a noble bride, and thus concerned male *ata rànja*, who by contrast to other slaves are obliged to marry exogamously, in the same way as the nobility. The results obtained when marriages with *ata ngàndi* are subtracted from the total are shown in Section (b) of Table 11.

The fact that slaves often marry persons attached to the same clan, however, does not entail that they marry close agnates; and in none of the cases where marriages had taken place between two families was it possible to trace an exact agnatic relationship between them. While marriage between slaves of the same clan does not take place

between clearly defined or independent groups, therefore, the genealogical evidence indicates that the minimal unit of exogamy in this instance is a line comprising at least three generations, which is the extent of genealogical knowledge of most slaves.

Table 11. *Marriages of Slaves in Rindi*

	Number	Percentage
(a) All marriages of slaves		
Spouses from the same clan	225	35.3
Spouses from different clans	413	64.7
Total	638	100.0
(b) Marriages of male slaves of the nobility		
Wife taken from within the noble clan . . .	133	48.2
Wife taken from another clan (excluding <i>ata ngàndi</i>)	143	51.8
Total	276	100.0
(c) Endogamous marriages of slaves of the nobility		
Spouses from same lineage of the noble clan .	132	64.7
Spouses from different lineage of the noble clan	72	35.3
Total	204	100.0

In accordance with there being no change of corporate group affiliation in such circumstances, when slaves marry within the clan, no bride-wealth need be exchanged. In a sense this also applies when *ata ngàndi* are married, since the total marriage payment received for the noble bride is reckoned entirely to compensate the wife-giver for the loss of these women, and they are therefore incorporated into the wife-taking clan at the marriage of their noble mistress rather than when they themselves eventually marry. Marriage between slaves belonging to different named lineages of the noble clan also requires no bridewealth; but in this case the couple remain obliged to the lords of both groups. With regard to lineage, therefore, the affiliation of their children is equivocal, though it is usually reckoned to follow that of the father, at least when the family resides in a house belonging to his lineage. This seems to be related, then, to the preference for keeping internal slave marriages within the lineage, which, as shown in Section (c) of Table 11, is followed in about 65 per cent of cases.

Traditionally, I was told, when a slave married a woman from another clan, the marriage was arranged by his masters, who also paid at least part of the bridewealth.³⁴ The gift was then divided between the woman's lords and her own father. Evidently, however, this mainly concerns the higher ranking slaves (*ata bokulu*) of the nobility, since to obtain a wife (or indeed a husband) for a lower ranking slave (*ata kudu*) could formerly have been done by straightforward purchase (see Chapter X). At the present time, by contrast the situation regarding slave marriages is somewhat variable, which apparently is largely due to the fact that slaves are now able to act independently of their masters, the traditional right of the latter to marriage payments received for slaves not being recognized by the government. Thus nowadays a slave might retain the entire bridewealth received for his daughter; and I also heard reports of slaves paying bridewealth entirely on their own account. In fact, while I was in Rindi, one marriage was thus contracted between slaves belonging to different lineages of the noble clan. This, however, took place without the knowledge or consent of the nobility of the wife's lineage; and I was assured that they would have objected strongly had they been aware of it. Indeed, the masters of slaves still exercise a good deal of influence over their marriages; and it seems that in many cases the traditional arrangements are still observed.

CHAPTER XVI

ADULTERY AND INCEST

The data I obtained in Rindi, mostly from the detailed descriptions of informants, that concern the procedures for rectifying incest and adultery, show these to be rather protracted and complex; and while limitations of space allow me to describe them only in a summary fashion, the ideas they reflect reveal a number of interesting and important connexions with certain more general themes of Rindi symbolic thought that I have found worthwhile to discuss. For this reason, then, rather than treating incest and adultery under the heading of marriage, as is commonly done, it has proved more useful to deal with these topics in a separate chapter.

1. *Njuraku*

As in other Indonesian languages, what we would distinguish as adultery and incest are covered in Rindi by a single term, *njuraku*. The word also applies to breaches of the prohibition on sex within the clan, and sometimes to promiscuous sexuality with unmarried women who are not categorically prohibited as spouses.¹ According to native etymology, *njuraku* is related to *njura*, 'upside down, back to front', especially, I was told, with reference to the improper inversion of 'trunk' (*pingi*) and 'tip' (*kapuka*).² Since not every instance of what is called *njuraku* can easily be conceived as a literal inversion, however, it seems that the word in this context is employed as a sort of metonym for disorder and deviance in general. That this is what incest and adultery pre-eminently represent for the Rindi is shown by their description of such offences as *kaliutu* (*la kuru uma*), 'confusion, complication (within the house)'. Nevertheless, in respect of their concern to orient relations in single irreversible directions, it seems significant that they should apparently focus upon inversion to express this more general idea.

Adultery can be distinguished from incest according to whether the offence (*njuraku*) involves 'another man's wife' (*papaha tau*) or 'someone who is not possible (as a spouse)' (*pandapeku*). Logically, therefore, incest should be defined as sex or marriage with women who are not *balu*; but in practice it is restricted to more closely related members of prohibited categories. Affairs between agnates, i.e., within the clan, however, were said always to be treated in the same way as incest between close relatives.

2. Adultery

The Rindi maintain a sharp distinction between adultery with wives of clan mates (by which they refer mainly to men of the same generation, *angu paluhu*) and adultery with wives of men belonging to other clans.³ The former offence, I was told, is far less odious and requires little more than a cooling ceremony to resolve. It is a purely internal matter; there is no fine; and, ideally, the cuckold should be magnanimous towards the offender. In the popular view at least, it seems usually not to lead to the spouses' separation. In contrast, adultery outside the clan is among the most serious of customary offences, and it is thought likely to lead the cuckold to physical violence, even murder. The Rindi thus describe it as *pameti wàngu*, 'something that can lead to death'. The woman, too, usually receives a good beating, and the spouses often separate for a time. As noted, it is the husband's wife-giver, the wife's natal group, who must mediate in the dispute and receive the fine (*palohu*) from the adulterer; and at no point do members of the adulterer's and the cuckold's clans meet one another. The principal portion of the fine consists of two horses and two pairs of metal pendants with chains, while two further pendants with chains are given in exchange for a cloth. The adulterer's group must also slaughter a pig, which they dedicate to their own clan ancestor and to the ancestor of the offended husband's clan.

The major part of the fine is called *dànga luri*, *dànga meti*, *ihi ngaru luri*, *ihi ngaru meti*, terms which denote funerary prestations and grave goods, while the two additional pendants are indicated with phrases that otherwise designate the metal bowl and other paraphernalia used in mortuary offerings. The idioms thus reflect the Rindi representation of adultery as an act which symbolically brings about the death of the cuckold. In addition, there is the idea that adultery brings the 'life forces' (*ndewa*) of the husband and adulterer into

conflict; so in the absence of compensatory procedures, the offence can easily result in the husband's actual death.⁴ Adultery might therefore be described as a total offence against the person of the offended husband. The origin of these ideas, I suggest, is a conception of the offence as something disruptive of the cuckold's marriage, and hence of the alliance connexion with his wife's natal group, which, as I have shown, is regarded as a source of life and prosperity. It is thus said of the adulterer that 'he befouls the inside of the house, the centre of the house floor' (*na-kubaruya na kuru uma padua kaheli*), which might refer either to the marriage or to the wider alliance (see Chapter XIII, Section 4). If adultery is seen to damage seriously this vital link, therefore, it can only imply a sort of death; so it is appropriate, then, that the party who undertakes to repair the damaged alliance should be the source of the vital connexion, namely the husband's wife-giver.

This theme is further suggested by the subsequent exchange of masculine and feminine goods between the offended husband's group and the wife's natal group, a procedure described as a 'reconciliation' (*pandami*). The wife-giver provides one pair of textiles called 'compensation for the wife-taker' (*ndoku la ana, ndanga la homu*) plus another pair, given formally in conjunction with counselling the woman as to her marital responsibilities, in order to normalize relations between the spouses. The husband's group then reciprocates with horses and metal valuables, and each party slaughters a pig for the other. A cooling ceremony is then performed 'to cool the house' (*pamaringu uma*) and 'to return the soul(s)', especially that of the husband but also, I was told, that of the wife.⁵ A connexion between sexual transgression and death is further encountered in rites concerned with incest, though in this context it is the guilty parties themselves who, by virtue of their illicit relation, are primarily at risk.

That these ideas are apparently not entailed in adultery with an agnate's wife, and that in this case the wife's group is not required to intervene, can be ascribed to the fact that the adulterer and husband are related categorically in the same way to the same wife-givers; hence the alliance relation suffers no damage. In this connexion, it is worth mentioning the custom reported by de Roo (1890:577) and Kruyt (1922:513), whereby a man whose wife is childless may request a brother or other agnate to act as genitor in his place (an undertaking which, according to the latter authority, is usually kept secret). While

younger persons in Rindi denied that this was possible, invoking the principle that a man does not have the right to make his wife sexually available to another party, one elderly informant, while acknowledging this rule, claimed that a childless man might nevertheless encourage his wife's attentions towards a certain agnate in the hope that she may become pregnant. He also stated, however, that a husband could not openly request such a service of an agnate.⁶

3. Incest

The Rindi regard incest as a most serious impropriety, describing it as 'dirty, disorderly' (*marihaku*) and 'hot, dangerous, excessive' (*mbana, mbangatu*). Even so, I did not find horror or revulsion to be their typical reactions to the offence, and they were surprisingly frank when talking about it. Although some informants did express opinions concerning the relative degrees of seriousness of different sorts of incest, it would be difficult to construct a comprehensive scale from the most to the least culpable that would be widely agreed to. In general, however, incest with a mother, daughter, or sister are (probably in this order) considered the worst, although an affair with a genealogical MZD or FZD was said to be as bad as one with a full sister. There is, in addition, the idea that sex with a *mamu* (FZ, etc.) is particularly odious, and in the opinion of some it is worse even than incest with one's own mother. It is so serious, I was told, that despite the procedures employed to this end, it is actually impossible fully to rectify it. The especial disapprobation of this sort of incest can be ascribed to the fact that FZ is simultaneously a natal member of one's own clan, of a higher and adjacent generation, and (potentially) of a wife-taking group. In structural terms, therefore, it may be said that everything is wrong with it. Its undesirability possibly concerns as well an evident structural difficulty in indemnifying a wife-taker; for what can be called a fine in Rindi normally consists of goods of the sort given to a wife-giver.

Despite the behavioural constraint required in the relation of HZH and WBW, an affair between such persons, or one involving a *tuya kawini* (MBW, WM, etc.), was actually judged less serious than the types just mentioned. Indeed, since I was told that a sexual liaison with members of these wife-giving categories is culpable, to the extent that a compensatory payment would be required at any rate, only when the woman is married, this sort of transgression is probably

more accurately classed with adultery than with incest. Sex with unmarried women in the second ascending or second descending generations was said not to be serious and to require no reparation or ritual. It would appear, however, that this refers only to distantly related members of these categories who belong to other clans. Sex with closely related 'grandmothers' (*apu*) or 'granddaughters' (*umbuku*), on the other hand, was reckoned never to occur.

According to the Rindi, incest can result in illness or death for the offenders and their close relatives, and difficulty in childbed and barrenness for the woman. Both incest and adultery, as well as promiscuity in general, are also thought to cause syphilis (*kanjawangu*), which in turn is said to lead to childlessness and infertility. Illicit sexuality of all sorts further poses a threat to the fertility and well-being of the land, though I never actually heard that it could cause flash floods, drought, plagues, and pestilence, as Kapita (1976a:115) states.⁷ When incest is discovered, the offenders receive a severe reprimand from their elders, and they are required to make a public confession. If they live in close proximity or their attachment is somewhat permanent, they must be separated. In one case I heard of this was done by quickly marrying the woman to a wife-taking group. Formerly, if the couple proved recalcitrant they would have been banished. It was also claimed that in certain cases the offenders might have been put to death.⁸

The several, rather complex procedures for dispelling incest were described to me in some detail, and a few I had occasion to witness. When the offence involves a woman actually or potentially belonging to a wife-taking group (e.g., FZ, FZD, Z, D), an exchange of compensatory prestations must take place. Regardless of when the offence is discovered, I was told, the reparation should be postponed until the woman is married; otherwise 'there would be nowhere (no one) to face' (*nda ningu ngia pahanggangu*). Before the exchange, the two parties perform a rite which requires the services of the headman of a clan which holds the powers of the 'hot cool water' (*wai maringu mbana*; see Chapter V), in order to remove the heat of the offence. This procedure, however, does not only concern incest, for it may optionally be performed in cases of a wife's adultery or an affair between WBW and HZH as well,⁹ though in the former instance the rite takes place after the fine has been collected and the wife-giver and the offended husband's group are formally reconciled, and involves these two groups alone. In what follows I shall take as my guide

incest with a woman from a wife-taking clan (e.g., the FZ). The rite is then held in the wife-taker's house.

As a payment for his services, the functionary of the *wai maringu mbana* first receives from the wife-taker a metal pendant and chain with small pieces of gold and silver wrapped in cotton; wealthier parties, I was told, might also provide a horse. The wife-giver then formally transfers to him a length of cloth and a piglet, called the *kamba ndoku ràpa, wei ndoku itu*, 'cloth of an incorrect measure, pig incorrectly carried'. (An alternative to the second phrase is *wei pata itu*, 'pig which breaks the carrying pole'.) *Ndoku*, 'mistake, error, etc.', refers to the fact that the length of cloth is shorter by about one half than those ordinarily given to affines, which normally measure one fathom (*ràpa*). The pig and, accordingly, the pole (*itu*) on which it is carried are similarly undersized. Since the alliance tie is designated as a 'line of cloths, pole on which pigs are carried' (*londa kamba, malinggi wei*), it is clear that these items serve to represent the illicit relation as a marital alliance that is erroneous, false, and substandard. Thus the purpose of the rite is 'to break the pole on which pigs are carried, to snap the line of cloths' (*mbata malinggi wei, mbota londa kamba*), i.e., to dispel the illicit connexion. The functionary of the *wai maringu mbana* then consecrates the piglet and a small chicken to his special deity, and the animals are killed. After a small portion of each is set out with cooked rice as an offering on the front verandah, he then takes the entire carcasses together with the betel and areca used in the dedication, the cooking and serving vessels, the cloth, the carrying pole, and the metal goods, and returns to his house. As all these things are considered hot, they can thereafter be used or consumed only by members of the functionary's clan, who in this way take away the heat of the offence. The purpose of the rite is further expressed with the phrases 'to shut off the river, the river (that is) the gutter around a house, to flatten the mountain, the mountain (that is) the eaves' (*hunggurungu luku, luku kilimbonga, pedahu tandula, tandula ru kawindu*). In accordance with the use of the house as a symbol of alliance, these expressions thus represent the illicit relation as a building, which, by means of this rite, is so to speak demolished.

The next stage of the proceedings, at which the compensatory prestations mentioned above are exchanged, is called 'to sweep the earth where she (or they) sat down, to burn the wood, the wood she (or they) held on to' (*kanjeku tana, tana ngia patungguluna, rokangu*

ai, ai ngia paàpana). As I shall later elaborate, this is one of a number of expressions that represent the transgression as having taken place on the ground, or in other words outside the house. The Rindi also describe this undertaking as 'to bring down the high heavens, to raise up the deep earth' (*papurunya na awangu majangga, paditaya na tana mamajolungu*). The phrases, I was told, allude to the separation of the body and soul upon death; 'deep earth' thus refers to the grave. It was explained that owing to their transgression the guilty couple should actually die, but by means of the rite their deaths are averted or, stated otherwise, they are brought back to life (*paluri beli*). Possibly there is also here the idea of a death preceding a rebirth corresponding to the restoration of order. By bringing down the sky and raising up the earth, therefore, the life that is (potentially) taken away is restored.¹⁰ We might perhaps also understand by this the reconciliation of the wife-giver and wife-taker, who like the sky and earth are hereby brought together again. As noted, a wife-giver in Rindi is conceived to be a source; thus sex with a woman of a prohibited category may be seen to involve a defilement of that source. Accordingly, one pair of phrases that was said to describe an incestuous man, especially, it seems, one who has transgressed with a woman of a wife-taking category, is 'the one who has made turbid the spring (or water source), who has forked the head of the river' (*na makatubaru mata wai, na makarangatu katiku luku*).

That incest is seen to result in a sort of death for the culprits was further suggested by an informant's statement that, like the fine for adultery, the metal valuables given as compensatory prestations and the animals slaughtered are to be regarded as 'grave goods' or 'funerary prestations' (*dàngangu, ihi ngaru*). I was also told that the textiles received from the wife-giver should not be kept long but should soon be used again in exchange, lest they become cloths used to enshroud a corpse (*yubuhu*). The same was said of the horses and metal goods given by the wife-taker.

On this occasion, then, the wife-giver provides a man's cloth and a woman's skirt and the wife-taker reciprocates with a stallion, a mare, and four pendants with chains. The valuables are described as '(that which) brings together the ankles, shuts off the eyebrows' (*pera kuku wihi, pandàbi wuku mata*) and 'the weirs on the dry land, that which shuts out the sun' (*da hapangu la mara, da pandàbi mata lodu*), expressions which allude to a cessation of the sexual relation and a separation of the guilty pair.¹¹ After the exchange, the two

parties hold a cooling ceremony which, by contrast to the previous one, involves the functionary of the 'calm cool water' (*wai maringu m̀anjaku*), in order to neutralize completely the residue of the transgression and to invoke divine favour. One specific aim of the cooling rite is to ensure that no harm is done to the woman's fertility. At this time each party provides a pig, which the other slaughters. The flesh of these animals, I was told, may not be eaten by the guilty individuals; for to do so would be like eating one's own flesh.¹² Wealthier groups may further exchange two pendants and a horse for a necklace of beads and a pair of ivory armbands just before the meal is taken. This transaction is called 'the means by which the brother-sister (i.e., sexually prohibitive) relation is realized' (*na paana mini paanawiningu ẁangu*).

When incest occurs within the clan, or with a married sister, daughter, or father's sister, a further ceremony called *hawari kuru uma*, 'to purify the interior of the house', is required. Some informants thought it need not be held in the case of sex between MBS and FZD, while others thought it should. Since the procedures described above can also be invoked in cases of adultery, it is apparently this ceremony, then, which is specifically concerned with what we would usually call incest. Indeed, as regards sex with the mother or unmarried women within the clan, *hawari kuru uma* is the only ceremony that is performed, as in these cases there is no exchange of prestations. Although in the context of FZ-BS incest, for example, this rite might be thought repetitive, particularly with regard to removing the heat of the transgression from the house, this apparent duplication was said to be necessary owing to the gravity of the offence. When, as in the case of a married Z or FZ, two different clans are involved, I was told the ceremony should be held separately in the woman's marital house and in that of the man.

The rite, which I never saw performed, was described to me as follows. First, by way of a prestation and the slaughter of a pig, the principal engages the functionary of the *wai maringu mbana* to visit the house, in the company of three of the functionary's clan mates, at the rising of the morning star. On their arrival the four men proceed to pound four times on the four outer walls of the building with stones. This is called *k̀ambahu*, 'to knock, beat, or shake out', and is intended to drive the incest out of the house. I was told stones might also be thrown at the roof. On behalf of all the members of the lineage, who at this point are gathered inside the house, the senior

householder then formally enquires why they have been disturbed at such an hour, and the functionary replies that someone inside has committed incest. The householder then says: if that is so, 'put life into my eyes (*or face*), cool my liver' (*pamiripu matunggu, pamaringu etinggu*), to which the functionary responds by requesting the occupants to come outside.¹³ Everyone then descends to the river's edge. Over her usual clothing, the guilty woman wears an extra skirt, and the guilty man an additional waist cloth. She also carries a dog, and he a chicken.¹⁴ The two individuals then enter the water, thus immersing their clothes and the two animals. After replacing the dog and the fowl on the bank, they remove the skirt and waist cloth and allow the garments to float some short distance downstream, where the functionary of the *wai maringu mbana* waits to retrieve them. He retains both the clothes and the animals, and later sacrifices the fowl to his special deity. The dog, on the other hand, is not killed; its only purpose, I was told, is to bark so as to drive away 'what is warm and hot' (*na mambàraku, na mambana*).¹⁵ Since the garments evidently represent the crime of incest and, in a sense, the incestuous persons themselves, by actually allowing the clothes to float down the river this performance provides a clear visual expression of the general idea that what is hot must be removed downstream and eventually out to sea in order to effect a purification.¹⁶ Afterwards, another rite of cooling, involving the *wai maringu mǎnjaku*, is held in order to cool the incestuous woman's marriage and to ensure her fertility and future prosperity.

4. Summary Remarks on the Significance of Sexual Transgression

I mentioned above that illicit sexuality (*njuraku*) is represented in Rindi as taking place outside the house and on the earth. One of several expressions of this idea is the description of incest and adultery as 'using the earth as a sleeping mat, and stones as a pillow' (*topungu tana, nulangu watu*). This does not of course mean that forbidden sex is thought always to occur outside a building, but rather, I suggest, that such behaviour lies symbolically outside the bounds of social order, which is represented, in particular, by the house. Accordingly, the Rindi say the place of (legitimate) sex is inside a building with a raised floor.

Sexual transgression can thus be said to result in a confusion of the inside and the outside. It is 'wild' behaviour brought into the

community which defiles the house and creates disorder within the group or groups with which the house is associated. With reference to the clan ancestor, who is in a sense the principal occupant of clan buildings, therefore, one aim of rites employed to dispel incest and adultery is 'so that he (the ancestor) will not drink water mixed with weeds, or eat rice mixed with earth' (*ka àmbu na-unu mangu rumbangu, nga mangu tanangu*). Here 'weeds' (*rumba*, see Chapter II, Section 4) and 'earth' refer to illicit sex, which is thus seen to pollute the food and drink offered to the ancestor and so cause him to exact retribution. In respect of these associations, however, the disorderliness of sexual transgression further accords with the notion of the outside (in this case the area outside the house and village) itself being a source of disorder. A guilty couple are thus described as 'being like the entrails of a wild chicken, the liver of a wild pig' (*paura manu tatangu, paeti wei rumbangu*), since by contrast to the livers and entrails of their domesticated counterparts, which are used in augury, those of wild animals are said to be useless for this purpose; they were in fact described as disorderly. At the same time, the Rindi regard illicit sex as an offence against the earth;¹⁷ thus when the act is indeed committed on the ground, a rite of atonement must be held at the spot lest the earth take revenge on the culprits. As sexual transgression is also threatening to crops, at the annual rites performed at the agricultural altars metal flakes are offered to dispel the consequences of any such offences that may have been perpetrated on the land. Indeed, since cultivated fields are situated on land that has been cooled, in this context illicit sex was said 'to make the earth hot again' (*pambana beliya na tana*).

Being contrasted as cool and hot, therefore, the identification of licit and illicit sex with the inside and the outside respectively corresponds to a wider complex of symbolic associations that is fundamental to Rindi ideology (see Chapter VI). Since, as I have illustrated, unions that are judged in some way incorrect must be ritually cooled if they are to be accepted, these contrasts can also be discerned with regard to correct and incorrect marriages. Correct marriage, moreover, is symbolically connected with the inside in that it falls within the bounds of social order and, more specifically, because it is conceptually located within a wider alliance, sometimes represented as a house. As noted, marriage that deviates from the proper order implies 'movement to the left' (*palua kalaingu*), a principle extensively bound up with death, whereas correct marriage is viewed as an instance of the

opposite principle — ‘movement to the right’ (*palua kawanangu*) — which constitutes the essential condition of life and well-being. In this area of Rindi representations, therefore, there is a significant degree of correspondence between various binary contrasts of the most general kind. To summarize, then, these are related as follows: sexual transgression (*njuraku*) : proper marital or sexual relations :: hot : cool :: outside : inside :: left : right :: death : life.

CHAPTER XVII

PRESTATIONS

Before describing the various ways in which marriages are contracted in Rindi, it is useful to consider more closely the question of marriage prestations, or what are usually called bridewealth and counter-prestation.

1. *Components*

As I have shown, the exchange of prestations at marriage is one instance of a wider pattern of gift exchange between allied groups or, more generally, between two parties who are in some way opposed as superior and inferior. In contrast to the wife-taker's prestation on other occasions, however, the goods given in exchange for a wife are specified as *wili tau*, 'price, worth of a person'.¹ The wife-giver's prestation is then called *mbola ngàndi*, or, more completely, *mbola ngàndi, kahidi yutu*, 'basket(s) brought along, knife carried in the hand'. The first phrase refers to the practice of placing the goods in baskets, and the second to a woman's knife that is included with these.² While the expressions can be applied to the entirety of the bridewealth and counter-prestation, in a narrower sense they refer to the principal portions of each, which formally complete the marriage transactions. Like other prestations given by a wife-taker (or another party who is contextually an inferior), bridewealth consists of horses, metal pendants (*mamuli*),³ and chains of plaited metal wire. The counter-prestation comprises mostly textiles, but also *anahida* beads (Indonesian *muti salak*), ivory armbands, and the woman's knife. (This last item is given only at marriage.) Although they are not consistently confined to one or the other gift, the use of metal goods and textiles as bridewealth and counter-prestation is widespread in Indonesia; and, as in this case, the two sorts of prestations are not uncommonly distinguished as masculine and feminine goods. In Rindi,

the femininity of the counter-prestation clearly accords with the fact that it is transferred in the same direction as the bride; it is 'what is brought by her' (*na pangàndina*). The masculinity of the bridewealth, on the other hand, is consistent with the Rindi evaluation of it as the more costly and hence superior of the two prestations, as well as the association of its components with men. It is thus the superior party, the symbolically masculine wife-giver, who receives it.

Though the distinction of gender applies categorically to the two sorts of prestations, as Onvlee (1949:453) has observed each is further divided into masculine and feminine components. Thus horses given as bridewealth include both stallions and mares, while metal chains are considered masculine and metal pendants feminine. Furthermore, the pendants themselves, while categorically feminine, comprise male *mapawihi*, 'ones with legs', which have animal and geometric motifs fashioned at the base and around the edges, and female *makamuluku*, 'bare ones', which are undecorated. Although Onvlee does not expressly say so, Rindi informants confirmed that in opposition to horses, which as a class are masculine, all metal valuables are feminine. Recalling that, in context, women are associated with the inside of the house and men with the outside, this corresponds then to the classification of the two sorts of wealth (*banda*) as 'goods on the plain' (*banda la maràda*) and 'goods in the house' (*banda la uma*).

In accordance with the genders attributed to the more or less rounded pendants and the long slender chains, the Rindi recognize their shapes to resemble the female pudendum and the male penis respectively; hence on one occasion they were described as 'things that provide fertility and prolificity'. Several facts suggest that the two sorts of metal valuables are also symbolically equivalent to long slender betel fruit and round areca nuts. Thus marriage prestations are placed with a quantity of betel and areca in plaited trays of the sort used to offer these chewing ingredients to honoured guests and to spirits, while in other parts of Indonesia betel and areca are themselves widely used as marriage gifts. Several named portions of bridewealth in Rindi are moreover designated with phrases that refer to betel and areca.⁴ Although I cannot confirm whether they distinguish betel and areca as masculine and feminine, it is worth noting that these equations are made on Roti, where the chewing of these items is considered symbolic of the sexual act (Fox 1968:317, n.). In Rindi, the sharing of betel and areca by a man and a woman similarly connotes a sexual relationship. Therefore, *pakutangu*, 'to offer one

another betel (and areca)' means 'to be in love', while *kuta*, 'betel', is one word for 'lover'.

The contrast of gender is somewhat less clearly expressed among the counter-prestation goods. Since textiles are categorically feminine, however, the masculine component of the gift is evidently the woman's knife and the beads and armbands, in which regard it seems relevant that in contrast to textiles these latter items are all products of male labour.⁵ Once I was shown a fragment of an iron hoe and some unspun cotton that had been placed inside a basket of textiles given long ago at the marriage of a noblewoman. (The custom is apparently no longer followed.) These objects, I was told, symbolize the two kinds of women's labour: agricultural work, which takes places outside, and weaving, which is done inside the house (or, more exactly, beneath the building or on the verandah). We thus encounter here the same contrast as is shown by the two major components of the bridewealth. The textiles themselves include both men's cloths (*hinggi*) and women's skirts (*laiü*); and when a pair of cloths is given, one will be masculine and the other feminine.

The combination of masculine and feminine qualities is enjoined by rules that govern the composition of the individual increments of which a total marriage prestation is composed. In the first place, a pendant should always be given with a chain.⁶ This is the minimal prestation, which when given in exchange for a length of material (*tera*) serves to mark minor communications between allied groups (e.g., the setting of a time for a future meeting). It is also the most basic expression of the masculine/feminine distinction; thus while a pendant and a chain can be given without a horse, the reverse is not possible. Pendants can be used individually or in pairs consisting of one male and one female piece. A single horse is given with either one or a pair of pendants; and individual, named prestations may include either one or two horses. When two horses are given, one should be male and the other female. A major increment of bride-wealth in Rindi thus typically consists of two pairs of pendants, a stallion, and a mare. With the most expensive prestations, the number of horses may be raised to four, but this appears to be an elaboration of a more basic quantity.⁷

The composition of marriage prestations also reflects the value attached to even numbers, especially four and eight. In this context, the quality of evenness (or completeness) is clearly founded on a duality deriving from the prescribed combination of masculine and

feminine values. Thus it is easy to see how various applications of this principle, and the concomitant symbolic equivalence of the number two and its multiples (see Onvlee 1949:452), permit a systematic expansion (or reduction) of quantities with regard to individual prestations. Briefly, this involves treating a basic male/female pair (e.g., a pendant and a chain) as a unit (in this case feminine) when conjoined with another unit (e.g., a horse) of the opposite gender. The process may then be continued until the limit of two stallions, two mares, and four pendants, is reached.

The standard amount of counter-prestatiion for a pair of horses in Rindi is a man's cloth and a woman's skirt, and for one horse a textile of either sort. In major exchanges, I was told, a length of cloth (*tera pandâpilungu*; *pandâpilungu* is 'coupled, side by side') should be presented with each decorated textile; but nowadays this seems often to be dispensed with. Onvlee (1949:453) similarly mentions a Mangili prestatiion comprising one man's cloth, a skirt, a headcloth (*tera*), and a man's waist sash (*ruhu bânggi*),⁸ given in exchange for two horses and four pendants. In these instances the additional textiles appear to complement the man's cloth and woman's skirt in the same way as metal valuables complement horses. The most expensive sort of prestatiion provided by wife-givers in Rindi, however, includes, in addition to cloths, a string of beads and a pair of ivory armbands.

2. Valuation

The total value of a bridewealth varies according to the way in which a marriage is contracted, which affects the number of increments required and which in turn depends on the rank and wealth of the two parties and the tenure of their alliance.⁹ In addition, the quantity and quality of the goods is open to negotiation between the two groups, both prior to the transactions and while they are in progress. While bridewealth is thus often the subject of more or less protracted bargaining, this is not so with the counter-prestatiion. As noted, however, the two prestations should be in proportion, otherwise the marriage will not prosper. An inadequate counter-prestatiion also reflects badly on the bride, since it suggests that her father considers her to be of little value (see Onvlee 1973:89).

Apart from the number of components, the value of a bridewealth varies according to such factors as the size, colour, and sex of the horses, and the metal content of the pendants and chains. While

pendants are classed as either golden (*rara*, 'red') or 'silver' (*bara*, 'white'), individual pieces can vary considerably in their actual gold or silver content. Pendants consisting largely or entirely of tin (*tambaka*), moreover, are classified with those of a high silver content as 'white'. Both decorated (male) and undecorated (female) pendants may be either golden or silver, though the former are mostly golden. Decorated 'white' pendants are consistently of a high silver content. While I found marked disagreement regarding the gender of gold and silver (i.e., red and white) in Rindi, in this context at least, the majority opinion seemed to favour gold as the masculine metal, because of its higher value. Accordingly, when two pendants are given, a preferred combination is one decorated golden and one undecorated silver piece. If there are two pairs, then one decorated silver and one undecorated golden pendant may be added to the above. But it is also possible to give two pendants that are both golden or silver. Golden or decorated pendants are never transferred individually (see Onvlee 1949:453). In fact, single pendants seem invariably to be undecorated (feminine) ones of tin, which thus appears to accord significantly with the femininity of these ornaments as a class, in contrast to the chains. Major prestations, on the other hand, always include at least one golden pendant among the one or two component pairs.

The bulk of plaited metal chains are of copper wire (*lulu àmahu wudu*). These may be paired with any sort of pendant.¹⁰ For the most expensive prestations, which include pendants of high gold or silver content, however, golden and silver chains (*lulu àmahu rara/bara*, *kanàtaru*, and *halakululungu*) are sometimes used instead. The majority of these items are owned by the nobility. Where two chains of unequal value are given with pendants of unequal value, the more valuable chain belongs with the more valuable pendant. Pendants of gold and silver, and those with decoration, as well as golden and silver chains, are more prominent in marriage than in other instances of exchange between affines. Indeed, among commoners, who possess relatively few metal goods of the highest value, their use is virtually restricted to the principal portion of the bridewealth.

Variations in value among individual components of the counter-pretation are mostly accounted for by the mode of decoration and the colours of the textiles. Of the two sorts of men's cloths, for example, those decorated with red (*kombu*) dye are more valuable than those with only blue. The most highly valued women's skirts

are ones decorated with extensive embroidery (*laiü pahudu*).

As I remarked earlier, the Rindi speak of bridewealth in general as costly and difficult to muster. Indeed, while there are no absolutely fixed quantities, and the amount can vary considerably according to the factors mentioned above, in comparison with what is required in other Indonesian societies bridewealth in eastern Sumba can generally be called expensive. Thus, considering only horses,¹¹ even the simplest of marriages can involve the transfer of half a dozen or more animals,¹² and judging from informants' statements, payments that include 20 to 30 horses are not uncommon. With regard to a recent marriage between a wealthy Rindi commoner and a woman of lesser noble rank from Mahu, I was told on good authority that the entire prestation (which had already been discharged) comprised 100 horses; but this seems exceptionally high and was evidently due to the fact that the wife was of higher rank than the husband (see Chapter X). Both Roos (1872:49) and Kruyt (1922:500) state that eastern Sumbanese bridewealth is so high that many persons cannot marry. But this would seem to be somewhat exaggerated, as I did not find a high proportion of Rindi people who had remained unmarried for this reason. As I shall show in the next chapter, moreover, marriages can be contracted with a reduced bridewealth, and the payments can be spread over a number of years.

Bridewealth in eastern Sumba has by all accounts undergone a marked inflation, probably beginning 150 to 200 years ago. Formerly, I was told, the prestation comprised only a dog and a quantity of brass or other metal.¹³ The use of horses as marriage prestations is thus evidently a relatively recent innovation; so it would appear that the inflation has been mainly due to the expansion of stock raising subsequent to the creation of an export market in the mid-nineteenth century and the introduction of precious metals in the form of foreign coins given as payment for the animals. Kruyt (1922:500-01) thus states that whereas bridewealth in Kambera at one time consisted of only two or three horses, by about 1920 it had come to include from 15 to 20 or from 50 to 100 'golden ear pendants' and a great number of horses and buffalo.¹⁴

3. *Division of the Bridewealth*

Since a more detailed description of the component prestations entailed in the various forms of contracting marriage appears in the following

chapter, here I shall briefly outline only the major, named portions of bridewealth involved in the more expensive procedures. The exchanges that complete abbreviated marriage procedures are considered to be merely 'reflexions' (*mai*) and not true equivalents of these. As mentioned previously, the total bridewealth is divided into two parts: (1) the *pingi wili*, 'trunk of the payment', or *aya wili*, 'senior payment', i.e., the principal portion to which the term *wili tau* more specifically applies; and (2) the *eri wili*, 'junior payment'.

In Rindi, the major portion of the *aya wili* is called the *kundu patini, tularu epi*, 'nudging of the firewood, pushing away of the fire'. This alludes to the bride's mother's period of confinement after parturition, and is given to the bride's parents in recognition of their having raised the girl to maturity. It might therefore be seen as a compensation for their efforts, although 'nudging' and 'pushing away' could also be interpreted simply as a reference to the separation of the woman from her parents.¹⁵ The portion minimally consists of two pairs of pendants, a stallion, and a mare, all of which (in the high form of marriage) are expected to be of the highest quality.¹⁶

The second named portion of bridewealth is the *kuta rara, kaliti pangga*. *Kuta rara*, 'ripe betel' (*rara* is also 'red', 'gold[en]'), apparently refers to the component golden pendants. *Kaliti* is 'riding mount' or, more generally, 'a means of transportation', while the relevant sense of *pangga* here, I suggest, is 'to cross over'. Since the prestation is intended for the bride's mother's brothers, the phrases might therefore be translated as 'mounts that cross over', that is, from the wife-taker to the wife-giver of the wife-giver, thus as it were by-passing the actual wife-giver. In Rindi, the prestation is actually made up of two parts, the 'senior ripe betel' (*kuta rara ayada*) and the 'junior ripe betel' (*kuta rara erida*). The first, which comprises two pendants and a stallion is for the bride's mother's eldest brother, while the second, which consists of a mare and one or two pendants of lesser value is for a younger brother or, so I was told, for the mother's father if he is still living.

Another prestation, which in Rindi is (or was) given only at marriages of the wealthiest nobility, is called the 'ancestor portion' (*tangu marapu*, see Chapter V). This refers to goods which are in effect transferred from the heirlooms of the wife-taking clan to those of the wife-giver. The prestation minimally comprises a pair of valuable pendants given with two horses. In this connexion, it is worth mentioning the classification of eastern Sumbanese bridewealth outlined

by Kapita (1976a:132), who divides the total payment into two parts, the 'upper platform' (*ladi dita*) and the 'lower platform' (*ladi wawa*). Though I never encountered these terms in this context in Rindi, they otherwise refer to the loft in the house peak — the place of the ancestral spirit — and to the floor of the house. Under 'lower platform', therefore, Kapita lists both the *aya wili* and *eri wili*, while 'upper platform', he says, refers to a prestation of four pendants with chains and four horses that are intended for the clan ancestor.¹⁷ (Interestingly, Kapita's description implies that the major portion of the counter-prestation is exchanged for this part of the bridewealth, whereas in Rindi I was told that it is given in return for the bride's parents' share of the *aya wili*.) Onvlee (1973:87) mentions a former practice of giving a piece of unforged gold or a pendant to be added to the relics of the wife-giving clan that are stored in the peak of their ancestral house. This custom was said formerly to have been observed in Rindi as well, but it has now fallen into disuse.

Marriages of the very wealthy occasionally include another prestation for the wife-giver of the wife-giver, specifically the bride's mother's father or his heir.¹⁸ This is called the 'stake for the kapok and dedap tree' (*tandai ranga, tandai wälakeri*), and consists of a large stallion and two valuable pendants. The gift was described as a means of securing fecundity and prosperity from the recipient, which seems to involve the idea of the wife-giver's wife-giver as an ultimate source of well-being (see Onvlee 1973:92) and the desire that what this party has provided to the bride's group should now be extended to the groom's. *Tandai*, which denotes a wooden stake or living tree that supports climbing plants, thus suggests a life-sustaining function, while the two trees mentioned in the name of the prestation were said to represent the male and female genitalia. I was also told that, in contrast to their normal sitting position, the ritual speakers who convey the prestation should stand up while doing so.

Each of the prestations described above is reciprocated with a pair of decorated textiles (a man's cloth and a woman's skirt), while, in addition, a pair of armbands and a string of beads are given in exchange for the parents' portion of the bridewealth (*kundu patini, tularu epi*). The goods are then placed in one or more baskets bound with strips of cloth, which are not opened before the wife-takers have returned to their village. This principal part of the counter-prestation is distinguished as the *pingi mbola*, 'trunk of the baskets'. The various increments do not have individual names, though each can be specified

as the *papa*, 'complement', 'counter-part', of the portion of bridewealth in return for which it is given.

Once the principal bridewealth (*aya wili*) has been transferred, the exchange of those increments called 'junior bridewealth' (*eri wili*) takes place. As noted, these prestations, which at more expensive marriages account for the bulk of goods transferred between the two parties, are provided by the groom's father's brothers, others of his agnates, and other persons who contract to participate in the marriage. This part of the exchange is also known as 'what is placed in rows' (*pandalarungu*) or 'what is lined up (and) planted, put down (and) rooted' (*pandalaru pamulangu, pabànjalu pangaingu*). The names refer to the wife-giver's practice of arranging individual textiles (a man's cloth or a woman's skirt) in straight lines. Each cloth is provided by one of the bride's father's agnates, the bride's brothers, and other parties on the wife-giving side. They are then inspected and counted by the wife-taker's speaker, who gives a pendant for each textile; and the pendant, which represents a horse, is thereafter transferred to the person who provided the cloth. The horses may be given at the same time or, more usually, at some later, specified date. In the latter case, the animals are thus referred to as '(what is) counted by months, measured by years' (*kapàji wulangu, katutu ndaungu*).

In the more expensive forms of marriage, it is customary for the bride's parents and other close relatives to present the bride with a number of gifts in addition to the increments of counter-prestation exchanged for the bridewealth. Besides additional cloths — some of which are later presented by the bride to her husband's sister (*mangàlu*) — the gifts may include earrings, rings, and other jewelry; and also pendants, in this context described as *pamandara wàngu*, things that can later be used as a means of requesting foodstuffs and the like from the wife's natal group. Among the nobility, the woman's father usually provides the couple with several head of buffalo (*habàba*, 'one herd', i.e., a bull and several cows) and a riding horse, which, formally speaking, is for the bride. Where the husband is to reside uxorilocally, moreover, they will receive the usufruct of a parcel of land. It needs to be stressed, however, that these goods are not reciprocated in any direct or precisely calculable way in the bridewealth and thus do not form part of the counter-prestation proper; they are more in the nature of gifts for the bride, or rather the two spouses together. Kapita (1976a:62) describes them as 'capital' (Indonesian *modal*). While some of the items are of kinds normally

designated as 'masculine goods', therefore, they do not affect the classification of the two sorts of marriage prestations in terms of gender.

As noted, female slaves (*ata ngàndi*) are transferred with the bride at noble marriages, either at the time or subsequently. No additional bridewealth is given for these women when they themselves later marry; and though the wife-taker's prestation is in a sense considered to compensate the wife-giver for their value, the number of women given is not precisely calculated in relation to the amount of bridewealth. Despite their subordinate status, therefore, these slaves can no more be said to form part of the counter-prestation than can the bride herself. Rather, they are provided in consideration of the position of the bride, whom they will serve, in her marital home.¹⁹

Earlier authors (e.g., Onvlee 1973:89) also mention the practice of providing a noble bride with male slaves. In Rindi, however, I was told that such persons, who are there called *mahimbu kuta*, *mahimbu winu*, 'those who search for betel and areca', are actually the retainers of a noble husband who is formally required to reside uxorilocally for a time (see Chapter XVIII, Section 3). But while these men remove straight away to the bride's father's residence in order to serve her there, until the bridewealth is completed the husband may actually remain for most of the time in his own village. Such male slaves marry female slaves (*ata ngàndi*) of the bride.

4. *The Significance of Marriage Prestations*

I have already demonstrated that the payment of bridewealth secures the incorporation of the wife and her offspring into the husband's clan. That this, rather than the establishment of other rights, is the major significance of the prestation is especially made clear by the institution of *lalei tama*, 'marriage by entry' (see Chapter XV, Section 6), where the husband's right to the woman's sexuality and other services is the same as in other forms of marriage, but owing to the absence of bridewealth, the woman and her children belong to her natal clan.²⁰ The relation between bridewealth and incorporation therefore accords with the wider ideological significance of the gift as something exchanged for prosperity, in particular the possibility of continued existence for the wife-taker's lineage. As noted, valuables of the sort used as bridewealth, specifically precious metals, are also offered and consecrated to the clan ancestor and to other forms of

spirit, in order to secure divine favour; so in this context, as well, they are things given in return for the blessing of life and well-being.²¹ It is also worth recalling here that textiles, which form the bulk of the counter-prestation, serve as a symbol of the alliance itself (see Chapter XIII). Thus, in several contexts of ritual speech, cloths transferred between allied groups are designated as things that bind.²² Since childbirth is in some ways represented as analogous to weaving (see Chapter VII), moreover, textiles might in addition be viewed as symbolically equivalent to children. As mentioned earlier, the parties that receive bridewealth and counter-prestation, like the goods themselves, are distinguished as masculine and feminine respectively; so the exchange of marriage prestations can be considered as a process that unites masculine and feminine qualities with masculine and feminine categories. It is thus a symbolic expression of the proper order of things.

Despite the symbolic nature of the prestations, however, marriage exchange in eastern Sumba also displays something of an economic aspect. As noted, the bridewealth is called *wili*, 'price, etc.', a term which can apply to anything given in return for an alienable commodity; and, while the usage is considered impolite, the Rindi moreover sometimes speak of marriage in terms of 'selling' (*danggangu*) and 'buying' (*kei*, which, however, also means 'to receive') a woman. It is pertinent, then, that by contrast to other parts of Indonesia, where bridewealth often comprises valuables that have no other, or little other, use than in marriage exchange (see Fischer 1952:130; Barnes 1974:282), marriage prestations in Rindi consist, in varying degrees, of consumable goods that have other uses and can be exchanged in other spheres, which nowadays include commercial markets. This is especially true of the bridewealth. Thus metal pendants and chains also serve as ornamentation and grave goods, and in the internal economy they can be traded for foodstuffs and livestock (a practice which, apparently, is not a recent innovation). Horses, of course, have an even wider range of use and exchangeability; and before the imposition of colonial rule, both livestock and metal goods were commonly exchanged for slaves. It is clear, therefore, why horses (and to a lesser extent, buffalo) are the single most important symbol and criterion of wealth in eastern Sumba. Thus, while the term can be used in a more general sense, *banda*, 'wealth', refers especially to bridewealth, as opposed to counter-prestation valuables, and then particularly to horses and other large livestock.²³

Although cloths can be worn as garments and may also be used in barter, other than as counter-prestation their main traditional use — and the one which mostly accounts for their consumption — is in wrapping corpses for burial.²⁴ Apart from their occasional use as jewelry and grave goods, beads and armbands, on the other hand, have little significance except as marriage prestations; and deriving exclusively from import, they are the scarcest of traditional valuables.

Horses and cloths, the major components of prestations given by wife-takers and wife-givers respectively, are also renewable goods produced locally. Hence in this way, too, they are obtainable other than through alliance exchange. From this, and the fact that bride-wealth and counter-prestation valuables can be acquired through purely economic transactions, it follows that in principle the system is not only able to sustain itself in the face of temporary shortages but also to expand in scale. Indeed, this is what apparently occurred after the expansion of stock-raising during the last century. A further implication is that the alliance system is open to a degree of competition for both bridewealth and women. There are, however, a number of factors that serve to limit such competition. Among these is the previously mentioned ethic that disdains contracting marriages for economic gain, which is closely bound up with the precept that alliance connexions, once initiated, should be maintained and perpetuated. Competition for bridewealth, then, is really feasible only where marriages are not encompassed by existing alliance patterns; for otherwise the wife-giver is restricted as to the amount of payment he can reasonably demand (see further Chapter XVIII).²⁵ Accordingly, marriages that perpetuate existing ties tend to be less expensive than those which initiate an alliance.

The factors that limit competition, therefore, are the same as those which restrict the incidence of marriages that are irregular in terms of existing alliance relations, namely the rules of marriage themselves (in respect of both category and class), the preference for marrying a woman from the mother's group, and a strong preference for class endogamy. As noted, rank affects not only who may be married but also the amount of bridewealth a woman can command, a fact reflected in the statement by Roos (1872:49; see also Kruyt 1922:500) that in eastern Sumba as much must be paid for a daughter as was given for her mother. But, conversely, as I have also shown, in order to ensure a certain level of bridewealth from wife-takers, a group must continue to contract marriages with wife-givers of a particular rank

so as to maintain its own class standing. If a lineage were to begin taking wives of a lower rank with a view to economizing on marriage payments, therefore, they would no longer be able to obtain as high a bridewealth for their daughters. The Rindi themselves say a person cannot become rich through marriage exchange; for as much as is received at the marriages of women must later be paid out at the marriages of men. This, then, is one factor working against the hoarding and expenditure in other spheres of bridewealth valuables.

There are two other, minor restrictions on the way marriage payments can be expended which may briefly be recorded here. One is the rule that bridewealth received at a woman's marriage should not be used by her father or his brothers to obtain a (second) wife; in other words, that the goods can only be employed at the marriages of the woman's brothers. This, of course, is consistent with the previously illustrated opposition of adjacent generations. The second restriction is that bridewealth received for a twin sister should not be applied to the marriage of her twin brother, which is one expression of the general principle that opposite sex twins, because their relationship is considered incestuous, must be kept separate from one another in various ways.

Also worthy of mention here is a mechanism that is an inherent possibility of asymmetric alliance, but which the Rindi do not exploit in controlling the transfer of wealth at marriages. With reference to asymmetric alliance as practised in Kédang, Barnes (1974:289) notes that in this society the distribution of bridewealth valuables among groups is to some extent regulated by the tendency of goods to circulate between a number of parties, eventually returning to the original donor. Marriage cycles are thus valued and deliberately exploited to this end in Kédang, and so provide a means of preventing hoarding and competition. In Rindi, however, short cycles, especially, are not a preferred arrangement, and there is even a dislike in principle of all closed series of alliance connexions (see Chapter XIX). Though it is recognized that cycles can occur — as indeed they do — cyclical transfers of women and goods, therefore, are not significant for the institutional regulation of bridewealth transactions in this society.²⁶

In this and other respects, then, bridewealth perhaps assumes more the appearance of a purchase price in Rindi than in similar systems elsewhere. Even so, the Rindi themselves take pains to stress certain differences between marriage exchange and commercial transactions. Thus they remark that, unlike a seller of goods, a man may not offer

his daughter in marriage; it is the wife-taker who must request the bride. Should her father do so, it is then said that the woman is 'sold like dried betel fruit, traded like sliced areca nut' (*padangga meti kutangu, pamalanja winu nggobarungu*), i.e., like a mere commodity; and, further, that she is 'pushed about like a broken rice pestle, rolled around like a cracked mortar' (*pakahuru alu mbatangu, pakilu ngohu mberangu*), in other words, treated like something of little value. Interestingly, according to Onvlee (1973:89) the latter expression is also employed when a woman's father does not provide an adequate counter-prestation. Taken in relation to their other application, therefore, the phrases suggest that when the wife-giver's prestation insufficiently matches the bridewealth it is as though the woman were sold.

This interpretation relates to the more general point, that the existence of the counter-prestation distinguishes a woman's marriage from such commercial transactions as, for example, the purchase of a (female) slave. The traditional buying and selling of slaves in fact provides a particularly useful contrast to the exchange of women in marriage. There appear to be four main points of difference: first, by contrast to a slave, a bride once taken cannot again be transferred to another party (see Fischer 1952:128); secondly, valuables of any sort could traditionally be exchanged for slaves; thirdly, unlike a bride, a slave woman, though she may of course eventually be married to a male slave of the purchaser, is not necessarily intended as a wife for any particular individual at the time of her purchase; and, fourthly, the transfer of a slave does not in itself initiate an alliance. This last point is perhaps the most important, since it illustrates the fact that a marriage, unlike a commercial exchange, brings about or perpetuates a relationship between the principals which endures after the transaction is completed.²⁷

In this regard, then, we might also reconsider the idea of bride-wealth in systems of this sort as a replacement of the bride, or more exactly, of the bride plus the counter-prestation. If this is accepted in the strictest sense, then it must follow that the recognized disparity in value between the bridewealth and the counter-prestation represents the value of the woman herself. However, I doubt whether the Rindi would see the matter in this way; and in any case it seems not to be in accordance with their notions of propriety precisely to compute the worth of a bride in material terms. What is more, the disparity in value between the two sorts of prestations is manifest in every

instance of exchange between allied groups, regardless of whether the occasion is connected with marriage or not. Thus, since the exchange is continuous, it can be said that a true equivalence is never achieved, so that wife-takers can never fully compensate wife-givers materially for the value of wives and all they imply for the existence of the group. This interpretation accords with the wife-taker's subordination to and dependence upon the wife-giver. Clearly, therefore, rather than viewing marriage as a variant form of economic transaction, it is more usefully considered as an instance of a wider relation that involves the transfer in opposite directions of material goods and abstract values of different but complementary kinds.

CHAPTER XVIII

FORMS OF CONTRACTING MARRIAGE

Since about ten different ways of contracting a marriage were described to me in Rindi, it is not possible here to provide any more than a summary account of the main similarities and differences between them. The deficiencies of earlier accounts of eastern Sumbanese marriage procedures (e.g., Anon. 1855; Roos 1872; de Roo 1890; Kruyt 1922), all of which fail to distinguish clearly between these various forms, have recently been made good by the lengthy and detailed descriptions provided by Onvlee (1973:81-101). Unfortunately, however, like earlier writers, Onvlee treats eastern Sumba as a whole and does not specify to which domain or domains his observations are meant to apply. Although the procedures for contracting marriage do appear to be broadly homogeneous throughout the eastern region — which to some extent can be attributed to the incidence of inter-marriage between domains — differences are encountered from place to place; and it is such local variations, I presume, that largely account for certain discrepancies (some of which I shall mention below) between the information I obtained in Rindi and that provided by Onvlee. It may also be relevant, however, that the named procedures the Rindi distinguished can be called ideal patterns, in that they may be abbreviated, elaborated, or combined as circumstances permit. As contracting a marriage is usually a very protracted process, I had little opportunity myself to observe the component transactions, most of which are not public affairs, and like Onvlee (personal communication, 1974), who spent some 25 years on Sumba, I never witnessed the contracting of a marriage from beginning to end. The bulk of my data therefore derives from informants' descriptions.

1. General Remarks

It is important to note that the institution of marriage itself in Rindi

— the relation between the spouses, incorporation, ease of divorce, and so on — is not systematically affected by the way a union is contracted (see Rivière 1971:69); so what follows concerns only the different ways of initiating a marriage. The principal distinction among the various procedures is between those that require what may be called a full bridewealth and those in which the number and value of the payments are reduced. The latter are described as a 'shadow on the dry land, a reflexion in the water' (*maü mara, ninu wai*; see also Onvlee 1973:97-8) of the former, as they bring about the same result, viz., a legal marriage, but in an abbreviated and relatively impoverished manner. In these cases, the Rindi sometimes say that the bridewealth is not fully discharged. Yet this does not mean that the participants require or expect that it ever will be.

Certain features common to several forms of contracting marriage should first be mentioned. If the prospective spouses were not betrothed in infancy, it may be necessary to make a formal proposal by way of a prestation of horses and metal valuables called the 'banner which moves the heart, crest that stirs the inside' (*penji mapajuki, landu mapakeru*; see Onvlee 1949:450). Once this is accepted, and the total amount of bridewealth decided, the wife-giver visits the wife-taker to inspect the main portion of the payments.¹ As noted, Onvlee (1949:451) states that the inspection is carried out by the bride's mother's brother; while elsewhere (1973:85) he speaks in this connexion of 'a representative of this group'. In Rindi, however, I was told that although the mother's brother should be present, men of the bride's own clan are also involved in this affair. (Moreover, in this domain at any rate, it seems that a formal inspection requiring the presence of this relative is confined to unions contracted with a full bridewealth.) As the animal traditionally slaughtered for a wife-giver was a dog, the visit is called 'to go and eat dogmeat' (*lua pangangu ahu*; see Onvlee 1949:451). But since dogmeat is no longer a favoured food, at present, when all are satisfied that the goods are of a sufficient quantity and quality, the wife-taker slaughters a buffalo or pig instead, as the 'counterpart of the dog' (*papana ahu*). Sometime before a marriage is transacted, each side holds a meeting of all persons who are obliged (or contract) to contribute to the prestations, in order to formalize how much each will contribute. As this is done by slaughtering a pig, of which each contributor must partake, the procedure is called *pangangu kangàta*, 'to give (to eat) a small piece of meat'.²

As mentioned earlier, exchanges between wife-givers and wife-takers are characterized by indirectness and mediation. One expression of this is the idea that it is not good for the spouses' own fathers to take too active a part in the (informal) discussions that precede the formal transactions; and that these councils (which concern only members of one or the other party) should therefore be presided over by a father's brother of the bride or groom. Though members of both groups are present in the same house, usually the wife-giver's, the guests (wife-takers) are seated at the front while the hosts remain at the back of the building. The transactions are then carried out by ritual speakers (*wunangu*), who recite speeches in formulaic language that define the context and purpose of the exchanges. Each speaker is accompanied by a partner, called *kandehangu*, 'foundation', who at intervals acknowledges the communication of the opposite speaker with the expression *jiaya*, 'that is it, correct'. Thus the one speaker does not directly address the other. Speakers are also employed to carry messages between the principals in the settlement of procedural and other matters,³ both prior to the exchanges of marriage prestations and while these are in progress. As noted, minor communications, when formally conveyed, minimally require the exchange of a pendant for a length of cloth; so each exchange of words simultaneously involves an exchange of objects. The arrival of the guest group (usually the wife-taker) is acknowledged with the slaughter of a pig, called the *tanda tàka*, 'sign of arrival', and every major exchange of prestations is solemnized with a further slaughter. On each occasion the animal is dedicated to the clan ancestors, as a way of informing them and seeking their approval of what has transpired.

2. The 'High Form' of Marriage: Àpa Mamoha

Apart from elopement and traditional forms of forced marriage (see Section 5 below), there are two ways of contracting marriage with a full bridewealth in Rindi. The first, which is the more expensive and prestigious, and is practised only by the nobility and some wealthy commoners, is called *àpa mamoha*, 'to seize a *mamoha*'.⁴ *Mamoha*, 'adorned one', refers to a young woman of slave or lower commoner (*kabihu kudu*) rank who in this case acts as the bride's substitute. Another distinctive feature of the procedure is that at least the major portions of the bridewealth must be given before the bride is taken and the union consummated. It is therefore described with the phrases

'to follow like a ridge of hills, to split like a *bila* plant' (*patundu lindingu, pabera bilangu*), which indicate that the exchanges follow continuously on from one another until the prestations are complete. *Apa mamoha* is also the only marriage procedure which includes a full series of rites marking the wife's gradual incorporation into the husband's clan. It is mainly this aspect of the undertaking that I shall be concerned with here.

The actual transfer of the bridewealth takes place at the wife-giver's house. On this occasion, the wife-taking party includes all men who have contracted to contribute to the exchange and a number of women. The groom and his own mother, however, do not attend. Before the bridewealth is formally transferred, the bride is counselled as to her future marital responsibilities by her parents, her mother's brother, and his wife; and a pig is offered to the woman's ancestral namesake in order to request that she be afforded protection in her new home. Since the woman's name will eventually be passed on to female descendants of her husband's clan, the rite seems then also to involve the idea that the namesake as well as the bride is about to be transferred to the wife-taking group.

Once the main portion of the bridewealth (*aya wili*) has been discharged, the wife-takers are informed that they may 'stretch out (their) nails and extend (their) arms' (*malanggaru wu, madita lima*), i.e., prepare to take the *mamoha*. Wearing over her usual clothing a fine tubular skirt pulled up to cover her shoulders, and a conical hat with a long red veil obscuring her face, the young woman is seated at this time next to the main portion of the counter-prestation, with the women of the wife-giving group, on the left, feminine side of the house (*kaheli maringu*; see Fig. 1).⁵ The men of the wife-taking party, previously seated on the front verandah, then enter the house by the right front door (*pindu kaheli bokulu*) and cross over to the left side of the floor. On reaching the woman they utter four times the traditional men's cheers (*kayaka*), which are answered by their female companions, the women of the wife-taking group, who now sit in the right front corner of the building. At this point, the men encounter resistance from the women attending the bride's substitute. Amidst a cacophany, the women pelt them with coconut shell containers filled with dregs of the cooking pots, ash, and buffalo dung mixed with water,⁶ while the men cast small gifts of pendants and money in their direction, in order to placate them. Four of the men then carry the *mamoha* over to the right side of the house, while their companions

convey the counter-prestation. Though the bride herself remains in her compartment on the left side of the building, by removing her substitute to the right side, both women are formally transferred to the wife-taking party. From the point of view of her natal group, I was told, she then becomes a guest (*ariyaa*).

Once the minor prestations (*eri wili*) have been exchanged, each party provides the other with an animal to slaughter, a practice known as *patunungu*, 'to burn off (the hair of animals, as is done prior to butchering) for one another'. The wife-taker minimally provides a buffalo and the wife-giver a pig. After this final meal, the women of the host group exchange betel and areca with the guests, a custom always observed before an affine departs after a lengthy visit. This stage of the proceedings, called *pahâpangu* (from *pahâpa*, 'chewing ingredients'), is also known as 'the reciprocal touching of (tin) bracelets, the meeting at close quarters' (*patâbaku tamburangu*, *pajâmbaru kalihingu*), thus indicating that the two sides, which hitherto were separated and opposed, have now come together.⁷ As the bride's departure draws near, she is given further counsel, while the women of her natal group weep and perform exhortatory chants (see Roos 1872:50-1). When the wife-takers are ready to leave, four men carry the bride's substitute from the house and place her on a horse, which action the women of the wife-giving group again resist by pelting them with garbage. The bride herself leaves the house in a normal manner, and the wife-takers then depart. Since this is a highly abbreviated description, it is well to mention that the entire proceedings to this point can take many days.

Upon reaching the wife-taker's village, the bride's substitute is carried from her mount to the clan's ancestral house, seated in the right front section of the building, and unveiled. A buffalo or pig is then slaughtered for the clan ancestor, in order to inform him of the bride's arrival. This is followed by a period of celebration, which, depending on the wife-taker's resources, was said usually to last eight or sixteen days, broken by one or two rest days. Among the nobility, though, it might continue for a month or more. The festivities, which actually commence shortly before the party arrives with the bride, include dancing, special songs, and the playing of gongs and drums. Especially characteristic of this occasion is the women's circle dance (*pai*), which is also performed in several other ritual contexts that involve major transitions (e.g., the *langu paraingu* or 'feast of souls' ceremony). During this interval, the *mamoha* remains inside

the house, while the actual bride may come and go as she pleases.

Four days before the celebrations come to a close, a ceremony is held in order 'to wipe off the sweat (of the bride)' (*podahu wai hang-gobungu*). This is also done in other forms of contracting marriage, when the bride is first brought to her husband's residence. While the phrase alludes to the heat of the journey from the wife-giver's village, the rite was further described as a means of removing impurity, deriving from sexual transgression or other misdeeds possibly committed by the bride and her followers (the *mamoha* and the slaves, *ata ngàndi*, who accompany her) prior to her complete assimilation into the husband's clan. It is thus evidently intended to mark her separation from the former environment of her natal group; and to this end it is usual to invoke the powers of the 'cool water' (*wai maringu mànjaku*) by way of a minor rite of cooling.

The ceremony that terminates the celebrations is called *pamaiü papa*. *Papa*, 'partner, counterpart', here refers to the bride (and her substitute); *pamaiü* is 'to provide shelter, protection'. On the day before the ceremony, the forked upper part of a *kalihi* (banyan) tree, perhaps two metres in height, is cut, cleared of its smaller branches, and erected in the village square before the right side of the house. This is called the 'marriage post' (*andu lii lalei, lii mangoma*) and, like similar ritual foci located outside the house (e.g., the *katoda* altars), is identified with a presence represented as a male and a female spirit. Being of significance for the couple's fertility, in ritual language the post is addressed as 'the shadow and reflexion of the means of fecundity and prolificity' (*ninuna, maiüna na paworu wàngu, na pabàba wàngu*). Later, the trunk is removed from the village, replanted, and sprinkled with water. Should it live, the bride will bear many children.⁸

On the following morning (the day of the *pamaiü papa*), a priest places an offering of betel, areca, and chips of metal at the foot of the post. A buffalo and a red cock are then prepared for slaughter, and one of the ends of the rope attached to a ring in the buffalo's nose, by which the animal is held fast, is passed through the fork of the post. Four measures are then beaten on the gongs, and all in attendance give the traditional men's and women's cheers (*kayaka* and *kakàlaku*), after which the animals are dedicated by the priest and killed. Another four measures are then played on the gongs, and the rite continues inside the house, where a black pig and another red cock are offered to the clan ancestor and the deceased. After the meal, the *mamoha*

leaves the house and descends to the village square, where she must tread in the blood and feces of the slaughtered buffalo (*litingu tai, tunggulu ria*, 'to tread on feces, to alight on blood'). This is called the *puru tanangu*, 'descent to the earth'.⁹ A fracas then breaks out, with all in attendance pelting one another with congealed blood, dung, and other dirt (see Roos 1872:51). In some parts of eastern Sumba, the bride's substitute is carried around the house by women about this time (Roos *ibid.*:52). Though this is not done in Rindi, the custom is nevertheless strongly reminiscent of the Rindi practice of circling a house four times in an anti-clockwise direction with the new thatch just prior to completing the renovation, an act which is thus also linked with transition. Later, the woman re-enters the house by the right front door and proceeds to cross to the left side of the building, at which point her role as *mamoha* comes to an end.

The similarity between these procedures (including the use of numbers and colours) and other rites of passage is thus fairly clear; and we should especially recall the resemblance, mentioned in Chapter IX, between a *mamoha* and a corpse. In both cases, the use of a veil and additional outer garments (or wrappings) can be said to effect a separation (see van Gennep 1960:130), as can carrying the woman from the left to the right side of the bride's natal house. From this time until the end of the celebrations in the wife-taker's village, then, the *mamoha* appears to be in a marginal state of transition. This is indicated by her seclusion from the celebrants and the fact that, like a corpse, and later the soul of the deceased in the medial, transitional stage of the mortuary rites, the woman during this time occupies the right front section of the house — first in the natal house and later in the husband's. Her final passage to the left, feminine or 'cool' side of the wife-taker's house is thus a removal from a formal and spiritual place to one that is domestic and secular. The three stages of the *mamoha*'s physical passage are represented in Fig. 8.

The fact that the first two instances of passage (see Fig. 8) are marked by ritualized combat between the men of the wife-taking group and women of the wife-giving group seems to express the resistance of the natal clan, and its women especially, to the loss of a member.¹⁰ Though it is not clear who are the contestants in the final fracas that occurs when the *mamoha* 'descends to the earth', I suspect it may be the two sexes of the husband's clan; for at this point the bride is about to be transferred from a male realm, identified with the right side of the house, to that of the married women,

associated with the left. Since not once during the transitional phase does the bride's substitute come into contact with the ground, her 'descent to the earth' evidently initiates an incorporation into the husband's clan and village. After this is done, the *mamoha*, the bride, and her companions bathe in the river, an act which, as in other

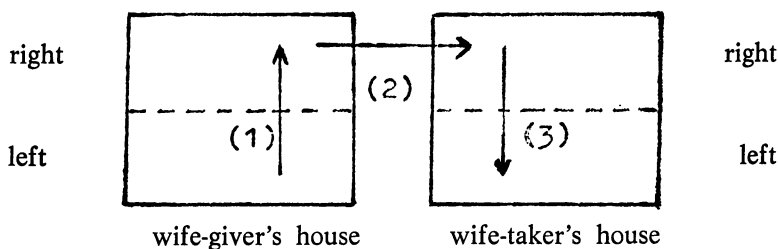

(The diagram is not intended to represent the actual disposition of the two houses or the exact route by which the woman is removed from one place to another.)

FIG. 8. Physical Passage of the Bride's Substitute

transition rites, further serves to effect the principal's reintegration into the mundane order. It is only then that the marriage can be consummated (*papohungu*, 'to squeeze together'). As with other transition ceremonies, sometime after the *pamaü papa* a cooling rite is held in order to return the house and its occupants to a normal condition and further to secure the bride's well-being.

3. *Tama la Kurungu*

Although the phrase *tama la kurungu*, 'to enter the (bride's) chamber', is sometimes used in Rindi to refer generally to forms of marriage that require a period of uxorilocal residence, it more properly denotes a specific marriage procedure which, like *àpa mamoha*, involves the payment of a full bridewealth.¹¹ Since the debt is discharged gradually and the husband must reside for a time with the wife's group, however, in these respects the procedure resembles some of the simpler forms of contracting a marriage I shall describe below. It may be followed by both nobles and commoners.

With this procedure, after the two parties agree to the marriage the groom goes to the bride's house in the company of a speaker and one or two clan mates. The portion of bridewealth given on this

occasion, which serves to confirm the marriage contract and establish the husband's right of cohabitation, is called 'sheath of areca, bundle of betel' (*kakomba winu, kawalu kuta*), and comprises a parcel of dried areca nuts and a string of dried betel fruit, as well as two or four horses and metal valuables.¹² The prestation is also designated as 'what is used to cross the hearthstones and traverse the hearth, to occupy the bolted door and the raised platform' (*palindi wàngu la tuluru, papàlaku wàngu la aü, pangiangu wàngu la pindu papaku, la nggala patundungu*). In formal speech, the related phrases, *lindi la tuluru, pàlaku la aü*, 'to cross the hearthstones, to traverse the hearth', are employed to denote the entire marriage procedure. Specifically, they refer to the manner in which the groom must enter the bride's chamber. From his initial position on the front verandah, he enters the right front door of the house and crosses to the left side, the place of the bride's compartment, passing by the front of the central hearth. On the way he must tread with his right foot in the ash between the masculine hearthstones (*tuluru mini*; see Fig. 1), an act which is said to promote the fertility of the union.¹³ The custom is thus reminiscent of the bride's substitute's stepping in feces and blood in *àpa mamoha* marriage and the fact that, in two instances, ash is one of the things thrown at wife-takers during the ritual combats that coincide with major points of transition in the more prestigious marriage procedure — the more so because these latter practices, too, were said to be conducive to fertility. Moreover, in this case, as in *àpa mamoha*, a transition — or separation — is symbolized by crossing from one side of the house to the other. Informants linked the groom's custom of treading in the ash with the phases 'my child between the hearthstones, in the heart (liver) of the hearth (ash)' (*anangu la njonga tuluru, la eti aü*) as a reference to wife-takers, which thus suggests that the usage further constitutes an affirmation or reaffirmation of his standing as an affine. In addition, during his period of residence with the wife's group, the husband is designated as 'a pig that does not go out, a chicken that does not descend' (*wei mandalulu, manu mandapuru*). Since both pairs of phrases are also applied to wife-takers in general, and ones of long standing in particular (see Chapter XIII), it seems significant, therefore, that the Rindi described *tama la kurungu* as an older and more traditional way of contracting marriage than *àpa mamoha*.

After the husband has resided with the wife's father's group for a time, the length of which varies according to the means of, and

agreement between, the two parties, the wife-taker pays a visit the wife-giver. This stage of the proceedings is called 'to place (oneself) by the dilapidated fence, by the tall grass, in the wide field, in the broad net' (*ngiangu la oka la mambowa, la rumba la majangga, ngiangu la woka la malerangu, la jala la mambàlaru*); and the portion of bridewealth given on this occasion is named 'the hoe for pulling up weeds, machete for cutting (wood for) a fence' (*pariku buta rumba, kabela punggu oka*). The phrases indicate the exchange to be an acknowledgement of the wife-taker's (more specifically the husband's) continuing obligation to provide the wife-giver with economic support until the bridewealth is fully discharged (see Onvlee 1973:90). It was thus described as a stop-gap procedure, carried out in anticipation of the wife's formal transfer to her husband's residence.

Before this transaction takes place, the husband must live and work with his wife's natal group, thus performing bride service, whereas afterwards he may divide his time and obligations between this group and his own, a situation the Rindi describe as 'going out in the morning, returning in the evening, rising (to go) back and forth, fetching to and fro' (*laku wàngu mbaru, beli wàngu malingu, hada luangga mai, piti luangga mai*). But while the husband may then return to his own clan, he is not yet formally entitled to take his wife with him. His actual residential situation at this stage of the marriage can be various. Sometimes the man returns to live more or less permanently in his own village (where he may have another wife), only occasionally visiting his (more junior) wife, who remains in her father's house.¹⁴ Alternatively, the wife's father might allow her to accompany her husband to his domicile before the bridewealth is completed, particularly when the two groups live close together. In fact, it sometimes happens that the woman is taken without her father's permission, which eventuality was mentioned as a possible disadvantage of contracting a marriage in this way. In other cases, however, especially when the two parties belong to different domains, the husband might take up permanent residence in his wife's father's village and build a house of his own there, with the result that a lineage of the wife-taking clan becomes established in the wife-giver's domain. There were several cases where this had occurred in Rindi.

I remarked that in this form of marriage it is expected, initially at least, that a full bridewealth will eventually be discharged. Not uncommonly, however, it has yet to be completed before the spouses' deaths; and while, if the husband dies first, the debt then formally

falls to his agnates and heirs, sometimes bridewealth is still outstanding generations after the marriage. Whether, in such cases, the wife-giver can still require that it be completely paid off was a question to which I could never obtain an unequivocal answer in Rindi. Usually, I was told, the matter is just 'left, put away' (*pabànjalu*),¹⁵ and further, that after a wife's death, outstanding bridewealth is normally not demanded, so that to all practical intents and purposes the matter simply 'disappears' (*mohu*). It is however required (or, at any rate, preferred) that the medial stage of the transactions described just above be completed during the spouses' lifetimes, and especially before the death of the husband. The reason given for this was that it is not good to die in a wife-giver's house, that is to say, while formally residing apart from one's own clan.

The final bridewealth transaction, which completes a marriage contracted in this way, is called *luhu liu, puru tanangu*, '(to be) released, to descend to the ground' (see *luhu*, 'to go out'; *liu*, 'back, hind part'). The second phrase is thus the same at that denoting the rite that marks the final assimilation of the wife into the husband's clan in *àpa mamoha* marriage, though in this context it apparently refers instead to the husband. While the terminal payment of bridewealth is formally equivalent to the major portion (*pingi wili* or *aya wili*) given in the highest form of marriage, the quality and quantity of the components will be lower. There is also a 'junior bridewealth' (*eri wili*), but this, too, will be on a reduced scale, with fewer parties on both sides taking part. The *pamaü papa* ceremony, I was told, is not held in this form of marriage.

4. Simpler Procedures

The several abbreviated forms of contracting marriage differ from one another mainly with regard to the manner in which the spouses' cohabitation is brought about. One of the more common of these, which is in effect a simplified version of *tama la kurungu*, is called *hariingu*, 'to make clear, make the daylight rise over' (see Onvlee 1973:96). After the two groups informally agree to the union, one evening the groom goes alone to the bride's house and proceeds directly to her compartment.¹⁶ As the name suggests, the object of his visit is to stay the night with the woman. When her father becomes aware of his presence, the groom must present him with a horse, two metal pendants, and a quantity of betel and areca; these serve

as the *kakomba winu*, *kawalu kuta*, mentioned above. The father then reciprocates with a textile, called 'the rope that binds firmly' (*kaloru hondu mandungu*), in order to show that he accepts the groom. Afterwards, he must notify his agnates and the bride's mother's brother of what has occurred and send a speaker to enquire formally of the groom's parents whether they are aware of and prepared to acknowledge their son's actions. As with *tama la kurungu*, after some time they provide another portion of bridewealth (the *kabela punggu oka*, *pariku buta rumba*), and the groom continues to do service for his wife's father. As in the other simpler procedures, in this instance the final transaction is usually referred to as *wuangu uhu mameti*, 'to offer food to the dead', a phrase also applied to the medial stage of *tama la kurungu*. Specifically, it refers to the offering of a pig to secure for the couple the favour and protection of the clan forbears. As the husband may now take his wife to his natal home, the major prestation given on this occasion, which typically includes two horses, is called 'that required to lay a garden in a far and distant place' (*patú wàngu woka la mamaliru la mamarau*).¹⁷ A few further increments will be given as 'junior bridewealth' (*eri wili*), and the wife's mother's brother will receive a prestation, but these will be far fewer than in the more expensive forms of marriage.

Generally similar to *hariingu* is a form of marriage called *tama rumbaku*, 'to break in, enter by force'. In this case, however, the groom, together with a speaker and several companions, enters the bride's compartment without the prior knowledge or consent of her father.¹⁸ The procedure was said usually to be restored to when an established wife-giver is reluctant to provide a wife, particularly if he has declined to do so for some time, with the evident intention of allowing the alliance to lapse. In this circumstance, then, it seems the woman's father would be under some compulsion to acquiesce to the marriage. But since he is yet in a position to make demands, the bridewealth, I was told, is likely to be higher than in other simpler forms of marriage, and the transactions should be completed relatively quickly. Kapita (1976a:125) states that for this reason the procedure sometimes comes to nought.

The practice known as *pandengi*, 'what is awaited, anticipated', was mentioned in Chapter XV. This differs from *hariingu* in that the prospective groom, who may or may not be of marriageable age, goes to live with and work for his prospective wife's father, typically a

closely related *tuya* (MB, etc.), well before the girl is ready to marry. As the latter still has the option of refusing his daughter should the youth's labours prove unsatisfactory, moreover, this period of pre-marital residence is actually a sort of probation (see Onvlee 1973:98). If all goes well, however, the woman's father will allow the couple to cohabit; and upon being informed of this, the groom's parents must then provide the equivalent of the *kakomba winu, kawalu kuta*. Although the wife's father may later allow the couple to remove to the husband's residence, as in the medial stage of *tama la kurungu* marriage their obligations remain divided between the two clans. While no further bridewealth might thereafter be given, it is preferred that another exchange (the *wuangu uhu mameti*) take place before the couple's decease, in order to formalize their removal to the husband's group.

Another simplified marriage procedure followed in Rindi is in certain respects an inversion of *pandengi*. This was commonly referred to as *paeti wikingu*, 'to follow one's own heart (liver)', the significance of which phrase was mentioned just above (see footnote 16) in connexion with *hariingu*. In this case, the prospective groom's mother, typically a father's sister of the bride, visits her brother and, by way of a prestation of two metal pendants and a horse, requests that his daughter, who is usually of a marriageable age, go to live with her to help with domestic chores. If the father agrees, another meeting, involving a further exchange of prestations, is arranged, and the young woman moves to her father's sister's house. Despite the way the request is phrased, the bride's father is aware from the outset of what is intended: eventually the young woman and the groom will begin to cohabit, after which the wife-giver will visit the wife-taker to complete the remaining transaction (the *wuangu uhu mameti*). With this arrangement, then, the husband is not required to reside uxorilocally for a time; but since a full bridewealth is not given, as in other abbreviated forms of marriage the couple still retain obligations to the wife's group.

Yet another procedure, generally similar to the one outlined above, is called *piti radangu*, 'to take and raise', and may be described as marriage following upon fosterage (see Chapter XV, Section 6). With this practice, however, the destined bride is taken while she is still a young child. When the girl is old enough to marry, the wife-giver is summoned to the wife-taker's residence to receive a payment of bridewealth, and the union is then established in a way similar to that

employed in *hariingu* and *tama la kurungu*. Since the husband's group has the benefit of the girl's service for a considerable time before her marriage, and the groom does not take up residence with her parents, however, the total marriage prestation is usually somewhat higher than in the other abbreviated marriage procedures. Besides the usual benefits of fostering a child, one recognized advantage of *piti radangu* is that it provides a means by which wife-takers may reserve a particular girl for themselves rather more effectively than by infant betrothal. The Rindi ascribe a similar advantage to *pandengi*, with regard to the possibility of the destined groom marrying a woman from a group other than an established wife-giver.

Discounting the institution of *lalei tama* ('marriage by entry') mentioned in earlier chapters, the most abbreviated way of contracting a marriage in Rindi is an arrangement known as *lalei ndàdiku*, 'to marry (and) remain'.¹⁹ As this typically involves an impoverished wife-taker, a prestation of one or two horses is sufficient to establish the union; and even then the payment might be deferred or, so it appeared from some cases, dispensed with altogether. What is more, the terminal transaction (*wuangu uhu mameti*) is not carried out. The husband therefore remains indefinitely with the wife's group; and since his obligations pass on to his children and descendants, a lineage whose founder married in this way becomes in effect a corporate extension of the wife-giving clan. Thus, although it concerns groups of commoners, the arrangement is generally similar to clientship (see Chapter X, Section 3). In this situation, moreover, the wife-taking group becomes effectively separated from the main body of its clan in both ritual and economic matters: members are buried in the wife-giver's village, rites on their behalf are conducted in this clan's ancestral house, and the wife-giver is entitled to one half of bridewealth payments received for the wife-taker's daughters. As the two groups exchange alliance prestations at one another's funerals, however, their relationship is not entirely the same as that of agnates. The main difference between this arrangement and the practice of *lalei tama*, therefore, is that in this case the children are counted as members of their father's clan; so that the alliance can be perpetuated through marriages contracted in the same way.²⁰ Indeed, it seems that such wife-takers are especially obliged to do so. Thus in one instance I recorded, the alliance had been continued for four consecutive generations after its inception, and encompassed seven marriages.

5. *Elopement and Marriage by Abduction*

The procedures I shall now briefly describe are recognized methods of contracting a marriage, and each can require a full payment of bridewealth. None involves a period of bride service by the groom.

Elopement, called *paluhu ngàndi*, 'to leave taking', or *palai ngàndi*, 'to flee taking', is not an uncommon way of marrying in Rindi. Normally the woman's group is not a previous wife-giver of the man's, though with regard to rank and category it is necessary that the relation between the spouses be such that the union can eventually be accepted.²¹ The groom's father may or may not know in advance of the couple's intentions, but the groom must nevertheless be fairly sure of his support, otherwise the marriage cannot be legitimized.

At the pre-arranged time, after nightfall, the groom goes with several companions to collect the bride. In order to indicate to the woman's father what has occurred and their intention to marry, he leaves behind two metal pendants with chains on her sleeping mat, and a horse tied up outside.²² Traditionally, he would also leave a replica of the distinctive ear markings of horses belonging to his clan, as a clue to his identity; nowadays it is more common to leave a note bearing his clan name. If the woman's father, after consulting with his agnates and her mother's brother, tentatively decides to accept the marriage, he sends a speaker to the headman of the groom's clan formally to enquire whether she has been taken by one of his members and to ascertain the individual's identity. The subject of bridewealth will also be discussed at this time. The visit is called 'to bar the gully, to cast a net on the plain' (*titingu kanjonga, nggerungu maràda*), which is one of several idioms employed in this marriage procedure that represent the woman's disappearance as though it were the loss of a horse or other animal. If all is in order, at some later date the wife-giver, with the bride's mother's brother, will visit the wife-taker 'to eat unripe wild figs, to drink water from a hollow trunk' (*lua pangangu kanjili muru, unungu wai kandoka*). The expression, which refers to a prestation of two horses and metal valuables, is an allusion to the sort of inferior foods one might have to resort to while desperately searching for a lost animal in the wild. It is thus given as compensation for the supposed discomfort and inconvenience suffered by the wife-giver while searching for the girl.

It is not entirely clear to me who receives this prestation. On the one hand, I was told that it is intended for the bride's mother's

brother; while according to another account this applies only in a formal sense, and it is actually her father who receives it. The mother's brother is then given an additional horse and metal goods. But whatever the case, the woman's mother's brother appears to be somewhat more prominent in this than in other marriage procedures, which is possibly related to the fact that he is not given prior knowledge of the union, which as noted normally involves previously unrelated parties, as he should be.²³

Later, arrangements are made to transfer the remainder of the bridewealth. If he is able, the wife-taker should complete the full series of payments, but if this is not possible the wife-giver may settle for a reduced amount. Contrary to Kapita (1976a:125), therefore, it is not quite true that elopement is feasible only among the wealthy. Nevertheless, generally speaking it is still more expensive than other ways of contracting a marriage, which accords with the fact that the union initiates a new alliance. Of course, the bride's father may not wish to accept the match, and even if he does, the transactions may later break down because the wife-taker is unable or unwilling to pay the amount of bridewealth he requires. Despite the factors that often induce the bride's parents to acquiesce to the marriage (see Chapter XV, Section 2), therefore, elopement is a rather risky venture and does not always lead to a (legitimate) marriage.

Marriage initiated by abduction is called *apa rambangu*, 'to seize and carry away' (*rambangu* is also 'to rob, loot, plunder'). Though instances were recalled in Rindi, the procedure is now a rather precarious recourse, as it conflicts with modern Indonesian law. A woman might be taken in this way, I was told, if she opposes a marriage proposed by her father or if her own father does not approve of a marriage favoured by others. In either circumstance, there must be other members of the wife-giving clan who are disposed to the union and who will actively support the wife-taker's plan. The two groups concerned are not always unrelated. I never heard that the procedure might be resorted to simply in order to expedite a marriage quickly, at the cost of a higher bridewealth, as Kapita (1976a:125) suggests. Nevertheless, the prestations are discharged in a relatively short time, and the total amount is normally high.

Two strategies were distinguished in Rindi. With one, the collaborators on the wife-giving side take the woman under some pretext to a desolate spot where, as previously arranged, they meet the wife-takers. The latter then seize the bride, with force if necessary, and

carry her away to their village, leaving behind two horses and metal goods to be given to her father. This procedure is called 'gully where there is a pig, copse where there is a monkey' (*kanjonga ningu weingu, kalimbu ningu buti*).²⁴ The collaborators then take the prestation to the bride's father and attempt to persuade him to accept the marriage. If he should acquiesce, speakers are sent to negotiate the bridewealth. The wife-giver's visit to collect the goods is then described as 'following the dug-up earth, the beaten grass' (*ndàkiya na tana matang-geli, na rumba mamajaja*). It is thus represented as a pursuit of the party that rode off in haste with the bride.

The other strategy, known as 'hawk in the sky, falcon over the sea' (*ikitu la awangu, tariku la tehiku*), seems to be the more appropriate when it is the woman's father, in particular, who would oppose the marriage. It also requires the support and intervention of the noble ruler, who is materially rewarded for his assistance. The nobleman summons the father, and others among the man's agnates who might put up resistance, to his residence and detains them there. The collaborators on the wife-giving side then send the woman outside the village on an errand, which opportunity the wife-takers use to seize and carry her away. Later, the prestation they leave behind is taken to her father at the nobleman's house, and the nobleman undertakes to persuade him to accept the goods and consent to the marriage. In these circumstances, I was told, he would invariably give in.

6. Comparative Remarks on Marriage Procedures

We may conclude this chapter by outlining several general differences, some of which the Rindi themselves articulate, between marriages contracted with a full bridewealth and those that involve only a reduced payment. First of all, it is held that the former procedures should ideally be followed when the union initiates an alliance, while the latter are more appropriate when a marriage involves established affines, especially the closest relatives in the prescribed category (see Onvlee 1973:97-99). This idea appears to relate mainly to differences in the quality and extent of the wife-taker's obligations in the two cases. With regard to *tama la kurungu* marriage, I remarked that the groom's period of uxorilocal residence, or bride service, is formally terminated when the full series of prestations is discharged. In this instance, then, bride service is required not only in consideration of

the bridewealth being generally lower than in the most elaborate form of marriage (*àpa mamoha*), but also because the bulk of the payment is deferred until well after the couple have commenced cohabitation. By contrast, with each of the simpler procedures, whether or not it entails a period of residence with the wife's group, the couple, and in a wider sense the husband's lineage, remain available to the wife-giver as a source of economic support even after the necessary prestations are complete and the wife has ceased to reside with her parents. This affects what can be called the texture of the alliance relation, as in this situation the wife-giver can freely turn to the wife-taker whenever he requires such things as animals for slaughter or goods of the sort used as bridewealth, without any immediate or balanced return.²⁵ Moreover, such wife-takers accompany their wife-givers to the funerals of the latter's own wife-givers and contribute — in the same way as own wife-takers — to the funerary prestations. In contrast, when a full bridewealth is paid any transaction between wife-giver and wife-taker, whatever the context, should be formalized with an exchange of alliance prestations and the slaughter of an animal. The idea that simpler forms of marriage are better suited to established affines thus seems to involve the notion that such wife-takers can be better trusted to fulfil their continuing obligations.

It is important to stress, however, that marriage between previously unrelated groups by no means always involves the payment of a full bridewealth, either because the wife-giver allows a simpler procedure to be adopted at the outset, or because the union is initiated within the framework of *tama la kurungu* but the complete series of payments is never discharged. Conversely, established affines may opt to contract further marriages by way of the more expensive procedures, so I was told, simply for the sake of prestige. Yet whenever bridewealth is not given in full there seems nevertheless to be a greater expectation, or, perhaps better expressed, a greater desire on the part of the wife's group, that the alliance will be continued. Therefore, it might be said that in this case the greater indebtedness, so to speak, of the wife-taker adds to the permanence inherent in the notion of alliance in general.

At this point it is useful to introduce the terms *lalei dalungu* and *lalei luhu*, both of which are rather variously employed in Rindi to distinguish contrasting aspects of different marriage procedures. The two expressions can be translated respectively as 'to marry inside' and 'to marry outside'. Although sometimes used to refer to the

simpler forms of contracting marriage as a class of procedures, *lalei dalungu* seems to be especially appropriate to unions thus contracted between existing affines. In this context, then, *dalungu*, 'inside', would appear to connote marriages that take place 'inside' or 'within' an alliance.²⁶ According to one opinion, however, strictly speaking the term should be applied only to *lalei ndàdiku* marriages, where as noted the wife-taker is virtually incorporated into the wife-giving clan. This, then, suggests a somewhat different implication of 'inside', though as it concerns the contrast between *lalei ndàdiku* and other simplified marriage procedures, the difference seems to be only one of degree. *Lalei luhu* (*luhu*, 'to go outside, leave'), on the other hand, is sometimes used to describe any marriage for which the necessary transactions have been completed, or where the couple are living with the husband's group. However, in a narrower acceptation, it specifies marriage procedures that entail a full bridewealth. As noted, *luhu* has the further sense of 'released, absolved'. With regard to the more specific definition of *lalei luhu*, therefore, it is significant that the making of a full payment by a group that has previously contracted marriages with a reduced bridewealth was said to imply a termination of the alliance. Conversely, I was also told that a wife-giver may require this to be done if the relationship is discontinued for some other reason. In some contexts, therefore, *luhu* apparently has the additional connotation of being 'released' from the alliance itself.

Regarding the advantages of the simpler forms of marriage (especially for the wife-giver, though for the wife-taker as well, particularly when a period of uxori-local residence is involved), it is clear that unions are more conveniently contracted in this way when the two parties reside close together. Indeed, this is usually the case. Marriages with full bridewealth, by contrast, generally take place between geographically more distant groups, and *àpa mamoha* marriage, in particular, seems invariably to involve clans resident in different domains. Accordingly, contact between such affines is comparatively infrequent and is largely restricted to formal occasions requiring an immediate and balanced exchange of goods. Since wife-takers are not available as a constant source of support, therefore, the higher bridewealth in this instance and the requirement that it be completed before the wife moves to her husband's residence (or, in the case of *àpa mamoha*, before the marriage can be consummated) can be seen to compensate the wife-giver for this disadvantage. It

may generally be said, then, that bridewealth tends to more expensive when affines live far from one another.²⁷

Another general difference between marriage with full bridewealth and the simpler procedures concerns the number of persons who participate in the exchange. Thus, whereas the former normally requires an exchange of prestations on a large scale, and, in the case of noble marriages, may involve the inhabitants of two entire domains, the abbreviated forms of marriage need entail no more than a transfer of prestations between the spouses' fathers and a few of their closest agnates (besides the bride's mother's brother). One obvious consequence of this is that smaller corporate (agnatic) groups are at a disadvantage as regards contracting marriages with a full bridewealth, the more so as most smaller independent lineages in Rindi are found among the poorer and lower ranking; thus the simpler marriage procedures are especially suited to relatively impoverished groups. The fact that these procedures are by no means exclusive to such groups, however, indicates that the sort of affinal relationship they entail is valued in its own right. Moreover, it is important in this connexion to stress that while the Rindi associate marriage with reduced bridewealth with unions contracted with established affines, it does not necessarily follow that poorer, and hence lower ranking groups more consistently marry in accordance with existing patterns of alliance than do wealthier and higher ranking ones. Indeed, as I show in the next chapter, the data from Rindi suggest the opposite to be the case. Here it should be recalled that previously unrelated groups as well as established affines can marry without a full bride-wealth, while the latter, too, can choose to adopt the more elaborate procedures.

In this regard, then, we need to consider further the previously mentioned generalization that marriages which fall outside existing alliance patterns tend to be more expensive. This has found support, for example, in the case of elopement and marriage by abduction, since as noted these procedures (which the apparent exception, in some instances, of one form of abduction) normally involve previously unrelated groups. As regards these particular methods of contracting marriage, the higher bridewealth might in part be seen in relation to the fact that the woman's parents do not consent to the union before the bride is (physically) taken, a consideration which, in a sense, applies to *tama rumbaku* as well. However, in the wider view bridewealth is higher when a marriage involves unrelated groups

because the wife-giver can then require that the components of individual prestations be of a higher quality and quantity. To make such demands of an established wife-taker, on the other hand, would be contrary to the spirit of the relationship. But even when this factor is taken into account, the amount of bridewealth in any particular case can still vary in accordance with the rank and wealth of the parties concerned. Thus, while the generalization that unions that initiate an alliance are more expensive than those which perpetuate an existing alliance is borne out by the evidence, this distinction is just one among several differential factors that can affect the scale of marriage payments.

CHAPTER XIX

PRESCRIPTION AND PRACTICE

The aim of this chapter is to determine the extent to which Rindi marriages conform to the stated rules and to consider how far unions reflect a stable pattern of alliance relations between groups. The evidence derives from genealogies collected from 66 descent groups of commoner or noble rank established in Rindi, thus nearly all those listed in Appendix II. Since marriages of slaves are ordered rather differently from those of free persons, and it was often not possible to obtain for this section of the population genealogical information adequate for the present purposes, slave unions must be considered separately (see Section 4 below).

On the whole, Rindi genealogical knowledge is rather poor; and while they claim it should be possible to trace a line of descent from a clan's founding ancestor (*marapu*) to currently living persons, few clans are in fact able to do so. The majority of genealogies I recorded thus comprised only between four and eight generations that provided useful and reliable information on marriages, and in many instances relevant details could be remembered for only three or four generations (including living adults). In part, this reflects the shallow depth of clan segments presently established in Rindi, and the fact that many have moved to the domain in relatively recent times.

The analysis of an asymmetric system of alliance must first take into account the nature of the groups that must observe the rule enjoining a unilateral transfer of women, in order to determine the incidence of marriages that constitute direct exchange and hence involve women in prohibited, patrilateral categories. As mentioned in Chapter XII, the groups which thus independently maintain alliance connexions in Rindi are entire localized patrilineal clans, named lineages of such clans, or lineages of a clan which, though not distinctly named, function independently of one another in all corporate matters.¹ Each of the 66 descent groups included in the sample falls under one

of these three headings; and hereafter, whenever I mention 'groups', it is to units of these sorts that I refer.

1. Evidence

The genealogical record for Rindi provided a total of 1,280 men's and 866 women's marriages. The disparity between the two figures is due largely to the fact that women's marriages are more often forgotten when recounting lineage genealogies than are men's, particularly in the earlier generations and, apparently, when the women went to geographically distant places. Since about 43 per cent of marriages (46 per cent of the men's and 38 per cent of the women's) were contracted with groups outside Rindi, I have treated all men's and women's marriages as separate cases. Those which took place between Rindi clans, therefore, are counted twice; so the total number of unions considered is 2,146. It is worth noting, however, that the results obtained from all men's and all women's marriages treated as separate samples do not differ greatly from those obtained when the two totals are combined.

There were 1,915 marriages for which reliable information concerning the previous relationship of the spouses' groups was available. In section (a) of Table 12, these unions are divided into: (1) marriages that accord with the asymmetric prescription, and (2) those that show a direct exchange of women between groups. In section (b), the asymmetric marriages are then divided into: (1) those with groups previously related as affines,² and (2) marriages that appeared to involve previously unrelated groups.

Table 12. *Correct and Incorrect Marriages*

	Number	Percentage
(a) Asymmetric marriages	1,849	96.5
Direct exchange	66	3.5
Total	1,915	100.0
(b) Marriages with previous affines	907	49.1
Marriages with unrelated groups	942	50.9
Total	1,849	100.0

For the marriages that constituted direct exchange, it was possible in about 60 per cent of cases to determine the exact relationship of the

spouses. These were mostly distant; and I found no instances of genealogical FZD-MBS marriage in Rindi. The closest involved a FFZSD, while other patrilaterally related wives included ZHBD (simultaneously BDHZ), FZHFZSD, FFZHWD, and FWDHWD (simultaneously FWDHFWD). The last specification refers to the mother of the last government raja of Rindi, who came from Matolangu, the ruling clan of Lewa, which generally takes wives from the Rindi nobility. Unfortunately, as I did not become fully aware of the genealogical relationship involved in this marriage until after I had left the field, I am not familiar with the circumstances; but since the woman's son subsequently married his genealogical MBD, Matolangu's position as wife-giver of this particular lineage (Uma Penji) of the Rindi noble clan has been maintained. In the other instances of direct exchange, however, the reversal has generally not been sustained; and at least half of these unions were admitted to have been entered into erroneously. Some, in fact, were never recognized by the spouses' lineages as legitimate marriages. In Rindi, there is no rite by means of which a woman can be removed from a prohibited category and adopted into a marriageable one in order to render a union correct, as is sometimes possible in systems of this sort (Needham 1960b; 1962:87), though apparently this can be done in other parts of eastern Sumba and in the western part of the island as well (see Kruyt 1922: 497-8).

The 907 marriages in which the wife was provided by a previous wife-giver include 33 cases where the closest genealogical relationship between the spouses placed the woman not in the prescribed category *balu* or the permitted category *dawa* (MBSD, WBD, etc.), but in one that is normally prohibited. These comprised 29 marriages with an *ina*, 3 with an *apu*, and one with a female *umbuku*. As noted earlier, however, the Rindi permit unions of these sorts in order to perpetuate an alliance when there are no *balu* available in a wife-giving group; thus it seems reasonable to retain these marriages in the total of those correctly contracted between previous affines. But in at least one case, which involved a woman related as FMFSD, the union was said to have been formed without the consent of the two groups concerned; and there were other marriages that involved closely related *ina* (including one with the FMBD) where this circumstance might also have obtained. Since I am unable to determine how many these might be, it is arguable, therefore, that all unions with other women from established wife-giving groups should be treated separately from ones

with *balu* or *dawa*. One solution, then, would be to omit them from the sample altogether, in which case the percentage of incorrect marriages would hardly change, while that for correct marriages with previous affines would be adjusted to 48.1. If, on the other hand, they were treated as incorrect and thus added to the marriages constituting direct exchange, the proportion of incorrect marriages would be 5.2 per cent. However, since the percentages do not thereby change significantly, and the 33 unions did, after all, take place between established wife-givers and wife-takers, hereafter I shall regard the figures given in Table 12 as accurate.

Another question relating to the definition of correct marriage is how we are to treat those unions where no previous affinal relationship between the spouses could be found. Because the Rindi themselves do not regard such marriages as incorrect, clearly the best solution, being the one that most accurately reflects their representation of the social order, would be to include them with those which perpetuate an existing alliance. The other possible recourse in this regard would be to discount such marriages altogether and to consider only unions correctly or incorrectly contracted with previous affines (see Barnes 1980:88-89). If this were done, then the proportions of correct marriages (with an established wife-giving group) and those resulting in direct exchange would be 93.2 and 6.8 per cent respectively. It is clear, however, that by any method of reckoning the number of marriages that deviate from the rule enjoining a unilateral transfer of women is quite low. The comparable figure given by Barnes (1974:296) for Kédang is (by different interpretations of the evidence) 7 or 11 per cent.

Table 13 concerns the number of Rindi unions that accord with the marriage preferences, as defined in Chapter XV. Section (a) shows marriages with women from the clan of the mother's brother as (1) a proportion of all correct unions, and (2) of those that involved previous affines. The number of marriages between genealogical MBD and FZS³ is then listed in section (b), as a proportion of (1) all correct marriages, (2) all unions with previous affines, (3) all marriages with women of the mother's brother's clan, and (4) marriages with the mother's brother's clan where an exact genealogical relationship between the spouses could be traced.

By comparison with what has been found in other societies that practise asymmetric prescriptive alliance, the number of marriages with women from the mother's brother's clan thus appears to be

Table 13. *Marriages with the Mother's Brother's Clan
and with the Genealogical MBD*

	Number	Percentage
(a) (1) Marriages with mother's brother's clan	489	26.4
Other correct marriages	1,360	73.6
Total	1,849	100.0
(2) Marriages with mother's brother's clan	489	53.9
Marriages with other established wife-givers	418	46.1
Total	907	100.0
(b) (1) Genealogical MBD	189	10.2
Other correct marriages	1,660	89.8
Total	1,849	100.0
(2) Genealogical MBD	189	20.8
Other marriages with previous affines	718	79.2
Total	907	100.0
(3) Genealogical MBD	189	38.7
All other marriages with mother's brother's clan	300	61.3
Total	489	100.0
(4) Genealogical MBD	189	76.8
Marriages with other genealogically traceable relatives from mother's brother's clan	57	23.3
Total	246	100.0

relatively high. The figure for Kédang, as a proportion of 687 marriages where it was possible to tell whether a woman from the mother's brother's clan had been married, was 17 per cent (Barnes 1974:297);⁴ and from data concerning 480 marriages with previous wife-givers, provided by Clamagirand (1975) for the Ema of Central Timor, Barnes (1978:24) finds this was done in 21 per cent of cases. With regard to the Ema, the comparable figure for Rindi, then, is nearly 54 per cent. The incidence of marriage with the genealogical MBD, the most preferred sort of union in Rindi, also appears rather high. The only

society for which we have clear comparable evidence is, again, Kédang, where marriages of this type amounted to only about 3.6 per cent of unions (Barnes 1978:21; 1980:83).⁵ In Rindi, by contrast, the figure for marriages involving genealogical MBD and FZS, computed as a proportion of all marriages, both correct and incorrect (thus, 1, 915), is nearly 10 per cent.

2. *Interpretation*

Barnes (1974:299) remarks that the low number of marriages with the mother's brother's clan in Kédang gives little reason to think that 'a systematic pattern of alliances' (i.e., enduring ties between component groups) is to be found in this society. More recently, he has contrasted Kédang marriage patterns in this regard with those found among the Ema, which, according to a provisional computation of data provided by Clamagirand (1975), show a proportion of marriages with established wife-giving groups as high as 76 per cent (Barnes 1978:25).⁶ Elsewhere, he reports the incidence of such marriages in Kédang to be 58 or 64 per cent (1980:88). If the percentage of marriages with previous affines is to be the relevant criterion, then clearly we must conclude that in Rindi, too, there is no enduring pattern of alliances, as unions of this sort accounted for only 49.1 per cent of correct marriages there. Partly because sufficient comparative evidence is lacking, however, on this basis the question of whether a 'system', in the sense in which Barnes uses the term, does or does not exist can at present be answered only in a tentative and somewhat arbitrary way.⁷ In this circumstance, therefore, it seems somewhat more useful to attempt instead to isolate institutional and other factors that might eventually account for such differences between societies which manifest essentially the same type of formal social order.

In Lehman's (1963:99-100) terms, Rindi appears to be an instance of an 'open system' of asymmetric alliance, that is, one which favours the formation of new alliances 'far and wide within and without the community'. As Lehman indicates, a pattern of this sort may be the outcome of political and demographic circumstances extraneous to the formal properties of the system itself. In this regard, then, we might note Onvlee's report (personal communication, cited in Schulte Nordholt 1971:129) that, as among the Atoni (Schulte Nordholt, *ibid.*), eastern Sumbanese lineages will attempt to increase the number of groups to which they give women while endeavouring to restrict

the number from which they take women. Actually, I never heard this idea articulated as such in Rindi. I was told, however, that it is advisable to try to limit the number of wife-giving groups invited to funerals and other undertakings that require an exchange of prestations, which thus evidently involves the same considerations as the strategy reported by Onvlee. But, on the other hand, the Rindi also hold that it is undesirable to have too many affinal groups of either sort.⁸

Whatever the case, the more general point, and one which is not open to dispute, is that (apart from the factor of social class) there is nothing to prevent Rindi descent groups from forming new alliances with any other in eastern Sumba and, arguably, even further afield; so the potential range of affinal connexions in this society is very wide indeed. As the high proportion of marriages contracted with clans outside Rindi suggests, moreover, there is no general preference for marriage within the domain. Consistent with this is the fact that Rindi descent groups are by no means allied by marriage to all others. Thus there is considerable scope for initiating new alliances internally as well.

Yet, in spite of the fact that these features pertain to Rindi marriage alliance in general, the genealogical record shows that the proportion of marriages contracted with established wife-givers and wife-takers, and hence the durability of particular alliances, varies quite markedly between different clans. Thus, rather than attempting to characterize the system as a whole, a more worthwhile endeavour is to consider factors that might account for some groups maintaining alliances more consistently than others. One obvious difference between alliance groups in Rindi is their current size (see Appendix II). To test whether this is a significant factor with regard to marriage patterns, I have counted separately unions with previous affines among the correct marriages of: (1) the 20 smallest groups, all of which currently have 12 or fewer members, (2) all groups with 20 or fewer members, (3) the remainder of groups (i.e., those with more than 20 members), and (4) the largest groups (those with 50 members or more). The results are presented in Table 14.

The figures thus reveal that the incidence of marriage with previous affines varies continuously between smaller and larger groups. However, the extent of this variation is not so great as to confirm whether group size is the most important factor in this respect or, indeed, the most significant feature distinguishing the groups included in the four

Table 14. *Marriages of Smaller and Larger Descent Groups*

	Number of groups	Total correct marriages	Marriages with previous affines	
			Number	Percentage
All groups	66	1,849	907	49.1
Smallest groups	20	174	78	44.8
Groups with 20 or fewer members	32	394	178	45.2
Groups with more than 20 members	34	1,455	729	50.1
Largest groups	10	708	382	54.0

samples. As the Rindi themselves report an association between higher rank and consistency of marriage with existing affines, it is possibly more relevant, then, that seven of the ten largest groups are ones that include a large number of persons of high class standing, while the majority of those with fewer than 20 members mostly comprise members of low rank. If we subtract the lower ranking groups⁹ from the sample of (10) large groups, and those of higher rank from the sample of (32) smaller groups, therefore, the proportions of marriages with previous affines are changed to 58.4 and 37.4 per cent respectively. A further test of the influence of class standing in this regard is provided by treating separately the marriages recorded in the genealogies of: (1) the six noble lineages, (2) the 14 highest ranking groups, (3) the 20 highest ranking groups, and (4) the remaining 46 groups. (Sample (2) is thus inclusive of (1), while sample (3) is inclusive of (2).) The results appear in Table 15.

Table 15. *Marriages of Higher and Lower Ranking Groups*

	Number of groups	Total correct marriages	Marriages with previous affines	
			Number	Percentage
All groups	66	1,849	907	49.1
Noble groups	6	118	82	69.5
14 highest ranking groups	14	645	392	60.8
20 highest ranking groups	20	904	513	56.7
Lower ranking groups .	46	945	394	41.7

Since Table 15 shows a variation of nearly 30 percentage points between the results obtained from the marriages of the highest (noble)

and those from the lowest ranking groups, it seems clear that class standing does indeed have a significant bearing on the incidence of unions with established affines.¹⁰ In addition, the nearly 70 per cent incidence of such marriages found in the genealogies of the six noble lineages is not much lower than the figure of 76 per cent for the Ema; so there is also reason to believe that some groups in Rindi do maintain stable and systematic patterns of alliance, among themselves or with other clans resident outside the domain. The consistency with which certain alliances are maintained between groups of high rank can further be seen from Fig. 10, which shows some of the marriages between the high ranking commoner clans Mahora and Dai Ndipi, contracted over five generations. Moreover, the fact that four of the six noble lineages currently have fewer than 20 members lends additional support to the hypothesis that class is more important in this regard than is group size.

There are several factors that may account for this disparity between different sections of the Rindi population distinguished according to class standing. First of all, as most lower ranking lineages are small, they generally displayed shorter and less ramifying genealogies — which therefore included fewer marriages — than those of groups of higher rank. Higher ranking groups of small current size, on the other hand, provided some of the longest and most detailed genealogies. (This is generally reflected in the totals of correct marriages given in Table 15.) A related fact is that many small groups of low class standing are ones that have most recently moved into Rindi. Thus the alliances they have subsequently initiated in this domain have yet to be continued for any length of time, while, also owing to the change of residence, older alliances maintained in their domains of origin have not been kept up. Accordingly, the marriages of (21) groups longest established in Rindi show an incidence of unions with previous affines of 54.3 per cent, thus over 11 points higher than that obtained from the sample of 46 lower ranking groups. As 16 of these oldest groups appear among the 20 higher ranking groups, and moreover 7 figure in the sample of 10 large groups, high class standing, a longer history of settlement in Rindi, and large current membership are thus generally correlated. In this regard, it is appropriate also to point out that, since lower ranking groups on the whole marry within Rindi more often than those of higher rank, the tendency to form new alliances is not positively correlated with the incidence of marriages contracted with clans outside the domain.

The foregoing considerations relate only to possible reasons why the marriages of certain groups do not show a high degree of consistency in respect of established alliances. But in the case of higher ranking groups, the greater incidence of marriages with previous affines can also be ascribed to a positive inducement which has less relevance for the remainder of the population. Because parties of high class standing are generally more wealthy and thus, for reasons already noted, in a better position to marry outside existing patterns of alliance, the fact that they appear actually to do so less often than lower ranking groups may seem surprising. But as I have previously demonstrated, in order to maintain class standing a lineage must continue to take wives of a certain rank; and it has a better chance of securing such women if it maintains relations with established wife-givers. Evidently, then, it is this consideration that provides higher ranking persons with a greater incentive to marry in accordance with existing alliances.¹¹ Given the value placed on maintaining class standing, it should further be noted in this connexion that, partly for demographic reasons, one's potential range of affines becomes the more restricted the higher one moves up the class hierarchy.

Because local clans may display internal differences of rank, which will then be reflected among the clan's various wife-givers, however, as regards preserving class, it is clearly even more preferable to marry a woman from the mother's brother's clan. This, then, seems to bear significantly upon the fact that marriages with the clan of the mother's brother account for over one half of all those which involved previous affines (see Table 13). Moreover, as might be expected, the greater importance of class in determining marriage practice among the higher ranks appears to be reflected in variations in the rate of marriage with women of the mother's natal clan between groups of different class standing. Thus, as a proportion of all correct unions, the incidence of marriage with the mother's brother's clan was 39.0 per cent among the six noble groups but only 22.0 per cent among the 46 groups lowest in rank. Regarding the relatively high rate of such marriages in general, it is particularly useful to compare Rindi patterns of alliance with those found among the Ema, who, although they maintain a high incidence of unions with established affines (76 per cent), marry women of the mother's brother's clan in only about 21 per cent of cases. The Rindi figures therefore suggest that, in contrast to what apparently obtains in some other societies that practise asymmetric alliance, when a wife is not (or cannot be) taken from the mother's

natal clan, a man will just as often marry a woman from an unrelated group as take one from another of his clan's wife-givers. In a sense, then, it may be a greater preference for marriage with the mother's brother's clan which in this society accounts for the generally high incidence of marriages involving persons not previously related as affines.¹²

Also relevant to the incidence of marriage with women from the mother's natal group is the fact that where component lines of a local clan are formally or informally distinguished on the basis of rank, lower ranking persons are restricted by the rules governing class inter-marriage from contracting unions with the own wife-givers of higher ranking agnates. Class, then, can have both positive and negative effects on this aspect of the system. The factor of class would seem further to account for what appears to be a comparatively high rate of marriage with the genealogical MBD in Rindi, for as noted, with regard to preserving class standing, this is so to speak the safest type of marriage. The fact is, however, that variations between higher and lower ranking groups in this respect are far less marked than in others. Indeed, as a proportion of marriages with previous affines, and of those with the mother's brother's clan, the highest incidence of genealogical MBD-FZS marriage is to be found in the sample of 46 groups of lower rank. To some extent, though, this might be due to the fact that, since these groups marry locally more often than others, it was more often possible in these cases to determine the exact genealogical relationship between the spouses. We should also recall that these groups generally display the shallowest genealogies. Nevertheless, comparison between different sections of the community suggests that marriage with the genealogical MBD is universally preferred in Rindi, and that it is not motivated solely by the desire to consolidate high class standing.

These observations lead naturally to the question, first raised in Chapter XII, of the nature of the alliance group in Rindi. According to the genealogical record, the average number of corporately independent lineages from which Rindi descent groups had taken wives was 11, and of those to which they had given wives was 8.¹³ With regard to the high incidence of marriages with the mother's natal clan and with genealogical MBD, therefore, this seems to suggest that it may be unnamed segments of a local clan, distinguished according to differences of rank or residence, or simply on the basis of lineal seniority, rather than the group as a whole, which in a sense perpetuate

alliances. Here, then, I refer to lineal entities generally equivalent to the 'lines of two or three generations' which Dumont (1957:22) specifies as the units of alliance among the Pramalai Kallar. Another indication that a pattern of this sort is discernible in Rindi is the way some informants evaluated marriages that resulted in a direct exchange of women between (local) clans. Thus in those cases I was able to investigate (about 40 per cent of the 66 recorded in Table 12), the union was often rationalized on the grounds that the male and female members of one or both clans were so distantly related as agnates that it need not be considered in breach of the unilateral prescription; and this was sometimes expressed in terms of the marriages involving two distinct 'lines' (*kaloka*) of at least one of the two clans in question. While *kaloka* does not in general denote any specific level of unilateral descent grouping, in this context, moreover, it was once defined as comprising only persons whose mothers and grandmothers (FM) derived from the same 'place' (i.e., clan). One marriage that was interpreted in this way, which involved the clan Katinahu and its wife-taker, Kanatangu, is illustrated in Fig. 9; in this instance the man had married his FZHFSSD.¹⁴

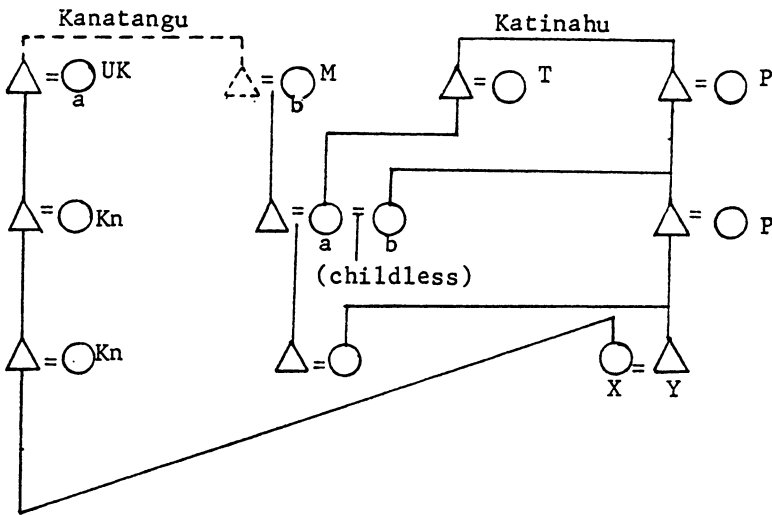

(The marriage which reverses the relationship is that between X and Y. Other natal clans of wives: Kn - Kanilu, M - Mahora Uma Bokulu, P - Pakilungu, T - Tawutu [a clan in Wai Jilu], UK - Uma Kambata [Ana Mburungu]. Co-wives are indicated with 'a' and 'b'.)

FIG. 9. An Instance of Direct Exchange

The suggestion that specific lineal relations are of significance for alliance in Rindi appears to find further support in the statement by one informant that, for purposes of bridewealth, first marriages with affines of distant agnates might be treated as new alliances. However, while I was told that marriage with a woman from the clan of a FBW (distinct from that of one's own mother) would not thus be counted as a new relationship,¹⁵ I was unable to ascertain how distant the agnatic connexion need be before this could be done, or whether there is any particular genealogical distance at which it is required.

Nevertheless, the general purport of this evidence is that individual alliances in Rindi are sometimes viewed as the property, so to speak, of specific descent lines. Consistent with this is a tendency for members of junior lines of a clan to contract marriages that initiate new alliances more often than do those of more senior ones, a pattern that to some extent is revealed in the genealogy given in Fig. 10. Yet it would be misleading, I suggest, to call such lineal segments alliance groups. As indicated previously, this term is most usefully applied only to the largest groups that are required to observe the rule enjoining unilaterality in the transfer of women; and the low incidence of direct exchange between such groups shown in Table 12 gives no reason to doubt that in Rindi this rule is generally interpreted as applying to corporately independent local clans, or to named lineages where these exist. Single descent lines, moreover, do not exercise corporate independence with regard to marriage: whom a person may marry concerns the local clan as a whole, and all members may be called upon to contribute to the marriage prestations. As noted, these corporate features are also characteristic of clans divided into named lineages; so in these instances the corporate (or 'bridewealth exchanging') group can be said to comprise several separate alliance segments, a situation which to a degree can further be discerned when members of other clans, at marriages of the nobility, for example, participate in the exchange of prestations.¹⁶

It is also pertinent here that the Rindi usually speak of entire clans as being their wife-givers or wife-takers. While normally this refers only to a local clan (the most inclusive agnatic group in respect of corporate action), moreover, a group that regularly marries with a segment of a clan localized in one domain will not uncommonly contract marriages in the same direction with other, independent segments of the same clan resident in other domains as well. Thus in this instance, it is indeed the clan as a whole (thus using this term

in its widest sense), or at any rate a larger unit of exogamy, that can be regarded as an affine.¹⁷ One example of this pattern is provided by marriages of the lineage Uma Pada Njara of the Rindi clan Mahora, which takes wives from the clan Dai Ndipi in Rindi, Mangili, and Umalulu (see Fig. 10). But even the named clan is not the highest level of agnatic grouping at which the Rindi can conceive of an alliance as operative. Thus, for example, a friend of mine could claim that members of a certain other clan were his affines (*kalembi*) simply on the grounds that they recognize the same *marapu* ancestor as the clan from which his FeBW derived; and he maintained that to take a wife from the former clan, as his FeBS had in fact done, would not constitute a new alliance. This, then, is apparently at odds with evidence indicating that alliance is sometimes represented as a relation obtaining between the smallest component lines of local descent groups. The fact of the matter, however, is that the level at which the alliance relation is seen to exist in Rindi can vary according to context; and it is consistent with this that, as I have shown in earlier chapters, different levels of descent grouping are concerned in marriages in different ways.

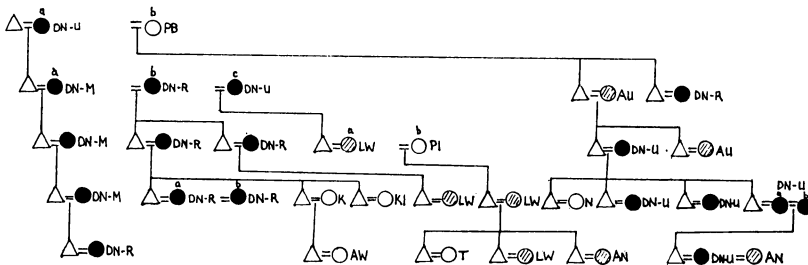

(Women from Dai Ndipi are shaded. Diagonal lines indicate other wife-givers who have provided women more than once [to members of the lines shown here only]. Lower case letters indicate marriage order of wives. Elder sons are to the left; younger to the right.)

Key: AN - Ana Nggela, AU - Ana Uмба (Mangili), AW - Ana Waru (lai Wunga), DN-M - Dai Ndipi-Mangili, DN-R - Dai Ndipi-Rindi, DN-U - Dai Ndipi-Umalulu, K - Karindingu (Mangili), KI - Kaliti (Mangili), LW - Luku Walu (Patawangu), N - Nipa (Mahu), PB - Paraina Bakulu (Umalulu), PI - Palamidu, T - Tidahu.

FIG. 10. Partial Genealogy of Mahora-Uma Pada Njara showing Marriages with Dai Ndipi and Other Wife-givers

3. Cycles

The asymmetric character of Rindi marriage rules entails that the transfer of women in this society is cyclic, and given that the system involves a finite number of groups, at some point alliance relations are bound to result in cycles. We might also recall, then, that the cyclicity inherent in this form of social order appears to be reflected in certain areas of Rindi ideology, for example, in ideas concerning the movement of spirit between the living and the dead. Yet, as Lehman (1970) has shown, societies that practise asymmetric alliance can vary considerably in what they make of cycles; and like certain groups of Chin (*ibid.*:118), the Rindi place no positive value on unions that result in or perpetuate cyclical marriage arrangements. Indeed, while some persons with whom I discussed the question seemed to be aware of the cyclical implications of their marriage rules, the general consensus was that circular alliances were undesirable and should be avoided; and while according to a number of informants the evaluation applies specifically to cycles of three groups, others, whose views I had equal reason to respect, claimed that all such arrangements, regardless of the number of their components, were bad. It should be recalled, therefore, that the Rindi have no customary procedures by means of which the cyclicity inherent in their alliance system could be exploited (see Chapter XVII); thus cycles do not entail any necessary advantages for the groups involved in them.

The Rindi explain their dislike of cycles on the grounds that by such an arrangement, a party classified as a 'wife-taker' (e.g., the wife-taker of a wife-taker) becomes a wife-giver. This agrees of course with the absence of closure found in the relationship terminology, and, in particular, the fact that there is no predetermined point at which affines one or more degrees removed matrilaterally or patrilaterally cease to be classified as wife-givers or wife-takers respectively. The objection was also expressed with reference to the idea that a cycle involves the 'tip' (*kapuka*, i.e., the wife-taker, see Chapter XIII) 'returning to' or 'turning back towards' (*belingu*) the 'trunk' (*pingi*, i.e., the wife-giver). Evidently, then, cycles are seen as a form of inversion. In this regard, it is significant that the expression the Rindi use to describe a cycle, *pai kili kulurungu, tuna weli wunjilungu*, 'circle dance that winds round and round, eel that coils back on itself', is also applied to the situation in which two distinguishable segments of a clan respectively give and take wives from the same

other clan. As noted, marriages of this sort are tolerated in Rindi according to the genealogical distance between the two parts of the one clan and the extent to which they otherwise contract marriages with different affines. Thus where these are named lineages or corporately independent segments of a clan established in different domains, this mode of alliance is perfectly acceptable. Nevertheless, at a higher level it can yet be conceived to result in inversion and closure; and it is apparently with reference to these features that such an arrangement is identified with a cycle.

The Rindi further explain their aversion to cyclical marriages on the grounds that the spouses are too closely related, i.e., matrilaterally and patrilaterally in the case of the wife and the husband respectively, so that 'the blood (transferred between the wife-givers and wife-takers) does not go out' or 'is not released' (*nda na-luhu na wai ria*).¹⁸ With three unit cycles, this of course agrees with the disapprobation of marriage with the FFZDD (or FZDHZ, ZHZHZ). Thus I was told that a marriage which results in a cycle of this sort should be ritually cooled in order to ensure the fertility of the couple, though it was also stated that once this had been done the component alliances, and hence the cycle, could be perpetuated. While longer cycles are considered less undesirable, they are still regarded as less than ideal. One problem with cycles in general which informants mentioned was that, owing to the extinction or disappearance of intermediate groups, they can gradually contract to just three, and eventually two, units. Perhaps, then, it is this possibility, in particular, which the Rindi have in mind when they claim that all cyclical marriage arrangements are to be avoided.

In accordance with their dislike of cycles, the Rindi turned out to be neither much interested in nor particularly adept at spotting them. They also stated that cycles which involve five or more groups (of which no one could provide an instance) would always pass unnoticed among the myriad alliance relations that connect Rindi descent groups, and would be of little concern to anyone should they occur. As is to be expected from the nature of the system, however, despite their negative evaluation of them, cycles can indeed be abstracted from the genealogies of Rindi clans; and, in case proof is required, I have listed 30 examples of three-group cycles in Table 16 below. In view of their opinion that such arrangements should be avoided, the question of whether cycles are less common in Rindi than might be expected in a similar society where cyclical marriages were positively valued

cannot be fully answered in the absence of sufficient comparative data. It is worth noting, though, that the short cycles recorded in Table 16 do not on the whole appear to be particularly stable, as in all except 3 of the 30 cases at least one of the three links comprises only one marriage.¹⁹ Furthermore, informants claimed that for a three-group cycle properly to count as such, it would have to link three single descent lines, and not simply three entire alliance groups, so that a man marries a genealogical MBD who is at the same time his FFZDD. This argument, it will be noted, follows the same form as that sometimes directed towards unions that result in direct exchange. Hence it is possibly to be understood as a rationalization, or denial, of short cycles that connect larger agnatic groupings when they arise.

Since the incidence of cycles, like the consistency with which unions are contracted with established affines, is in part a function of the number of groups involved in a local system of asymmetric alliance, the wide range of actual or potential alliances available to the Rindi may be one reason why cycles are little prominent in this society. In this regard, Rindi may usefully be compared with Nàpu, in north coastal Sumba, where although the relationship terminology and rules of marriage do not differ significantly from those found in Rindi, the great majority of alliances involve groups established within the domain. It seems significant, then, that information I collected concerning the marriage relations of 17 Nàpu descent groups revealed 40 instances of three group cycles.²⁰ What is more, persons I questioned in this domain expressed no objections to unions that form short cycles, though they also stated that these were not preferred over other modes of alliance.

Of further relevance in this respect is the fact that cyclical marriage arrangements in eastern Sumba generally appear to be most common among the nobility. It is therefore no coincidence that the instances of cycles which Needham (1957:176) abstracted from Nooteboom's (1940) genealogies all involve noble lineages. Indeed, the Rindi themselves remark that *pai kili kulurungu* marriages, which as noted just above include both cyclical arrangements and what appear to be symmetrical alliance relations when viewed at the level of entire clans, are most characteristic of the noble class. Since the nobility are a relatively small, elite group, the apparent reason for this is that owing to the rules of marriage concerning class, and given the value placed on preserving class standing, the nobles have a rather more

Table 16. *Examples of Three-Group Cycles*

	→		→		→	
1.	A (5)	K (5)	W (1)	A		
2.	A (5)	Kn (1)	W (1)	A		
3.	D (1)	Kw (1)	P (6)	D		
4.	D (7)	M2 (1)	Kn (2)	D		
5.	K (2)	Ana Umba- Mangili . (3)	M2 (5)	K		
6.	K (1)	Ana Waru- lai Wunga (1)	M2 (5)	K		
7.	K (1)	LT (2)	Kn (7)	K		
8.	K (6)	LW (3)	Km (1)	K		
9.	K (6)	LW (1)	Kn (7)	K		
10.	K (6)	LW (2)	Ph (1)	K		
11.	K (6)	Ma (2)	Ph (1)	K		
12.	K (1)	Mr (1)	Kt (5)	K		
13.	K (6)	W (1)	Kt (5)	K		
14.	K (6)	W (2)	M1 (4)	K		
15.	K (6)	W (3)	Pk (1)	K		
16.	K (1)	Wiki- Umalulu . (3)	M1 (4)	K		
17.	Kn (2)	Kt (1)	Mt (1)	Kn		
18.	Kn (1)	M2 (9)	PT (2)	Kn		
19.	Kn (3)	MW (1)	UP (1)	Kn		
20.	Kn (4)	T (1)	MU (1)	Kn		
21.	Kn (1)	W (2)	M1 (3)	Kn		
22.	Kt (1)	Mt (4)	T (3)	Kt		
23.	Kr (1)	W (3)	Pk (1)	Kr		
24.	Kr (1)	W (3)	Tr (1)	Kr		
25.	LW (4)	MW (1)	MbP (2)	LW		
26.	LW (4)	MW (1)	UP (3)	LW		
27.	M1 (1)	Mt (2)	P (3)	M1		
28.	M2 (2)	T (1)	P (1)	M2		
29.	Ma (2)	Ph (2)	MW (4)	Ma		
30.	MU (2)	UK (1)	Tr (3)	MU		

(Wife-givers are to the left; wife-takers to the right. The figures in brackets indicate the number of marriages between any two groups.)

Key: A - Ana Mburungu Kanoru; D - Dai Ndipi; K - Kanatangu; Km - Karambu; Kn - Kanilu; Kr - Karindingu (Rànga); Kt - Katinahu; Kw - Kawata; M1 - Mahora Uma Bokulu; M2 Mahora Uma Pada Njara; Ma - Maleri; Mr - Maritu; Mt - Matalu (Kanoru); MU - Muru Uma; MW - Marada Witu; MbP - Mbara Papa; P - Palamidu; Ph - Pahada (Kayuri); Pk - Pakilungu; PT - Parai Tua; T - Tidahu (Kalihi); Tr - Tarimbangu; UK - (Ana Mburungu) Uma Kambata; UP - Uma Paterangu; W - Wiki (Rànga).

The names of clans resident in other domains are written out in full. The second component is the name of the locality.

limited range of potential affinal connexions than do persons of lower rank. In respect of both the higher incidence of cycles and the greater extent to which they contract unions with established affines, therefore, marriage among the noble class in eastern Sumba might be said to approach what Lehman (1963:99) calls a 'closed system' of asymmetric alliance.

There is one further point concerning the class system that is worth making with regard to cycles and the Rindi evaluation of them. As noted, when marriage involves two parties of different rank it is normally the wife-taker who is of the higher class standing, and only in rare instances is the reverse the case. Thus, given a chain of three or more alliances in which women marry upwards, the initial wife-giver, so to speak, would not be in a position to take women from the ultimate wife-taker, since the former would be of lower rank, possibly quite markedly so, than the latter. In this respect, then, the general tendency in inter-class unions for men to marry lower ranking women clearly works against the formation of closed marriage cycles, and especially those comprising a small number of groups.

4. Alliance among Slaves

As noted above (see Chapter XV), the 638 unions of slave men and women I recorded in Rindi present problems of analysis not encountered with the marriages of free persons. Not the least of these stems from the fact that many slaves marry within the clan (see Table 11), in which circumstance, of course, marriage does not take place between independent descent groups. In many cases, therefore, the incidence of correct and incorrect marriages among slaves could only be determined by considering the previous relationship between the spouses. Because genealogical knowledge concerning members of this class was generally poor, however, I was able to find only 11 instances where this could be done with any degree of accuracy.²¹ Nevertheless, all these unions were correctly contracted with women whose genealogical relationship placed them in the categories *balu* or *dawa*, and three involved genealogical MBD and FZS; thus all conformed to the positive rule.²²

As regards whether slave marriages result in systematic patterns of alliance, however, these data are clearly insufficient; and where unions involve indistinct lines of the same clan, the question is in any case hardly relevant. Marriages between slaves belonging to

different clans, on the other hand, at least entail clearly distinguished exogamous groups. Yet unions of this sort, too, revealed little in the way of stable relations of unilateral exchange; and, besides, since slaves of a clan usually form a number of unconnected agnatic groupings, in this situation the clan can scarcely be called an alliance group.²³ Indeed, the only circumstance in which such marriages can be said clearly to take place within existing alliances is when slaves of the nobility marry *ata ngàndi* women (see Chapter XV, Section 5), since these unions can then be presumed to accord with such alliances to the same degree as do those of the nobility.²⁴

As noted, slaves employ the same relationship terminology, and in respect of category are required to observe the same rules of marriage as the rest of the population. In these regards, therefore, marriages of slaves can be said to be as much governed by the system of asymmetric alliance as those of anyone else. What in most cases slaves evidently lack, however, are clearly defined or enduring descent groups that could operate as independent units of alliance and hence maintain stable patterns of inter-marriage. It might be argued, then, that within this section of Rindi society, a system of asymmetric alliance exists in the absence of groups of this sort, a possibility first mentioned by Needham (1964:237) with reference to the Sirionó of Bolivia.

CONCLUDING REMARKS

Throughout this enquiry I have endeavoured to show how forms and relations manifesting the same principles of order, and expressed in several fundamental categories, govern diverse areas of Rindi life so as to compose a unity of thought and action.

The basis of conceptual and (insofar as they can be separated) social order in Rindi is a pervasive dual classification, the components of which are typically ranked and complementary opposites. The *modus operandi* of this system is an analogical type of thought in which, in given contexts, associations are made between homologous components of different category pairs whose members are related in logically diverse ways.

The most extensively applied binary distinction in Rindi, and indeed elsewhere in eastern Sumba (see, e.g., Onvlee 1949), is apparently that of 'male' (*mini*) and 'female' (*kawini*). As I have illustrated, these two categories provide a framework for classifying both concrete and abstract entities and values of the most various kinds. Since doubt has sometimes been expressed concerning the extent to which people whose representations are susceptible of analysis in binary terms themselves consciously formulate such dyadic distinctions, with regard to this opposition, in particular, it is worth stressing that the Rindi do indeed state quite explicitly that paired entities are distinguishable as masculine and feminine; and that they are often able to give cogent reasons for the attribution. Moreover, where a direct association or resemblance with things more manifestly male and female cannot be invoked as the basis of the classification, they may simply adduce the fact that the member of a pair specified as masculine is in some way superior to the other. This suggests, therefore, that the distinction of (symbolic) gender may be paradigmatic of the relation of inequality inherent in all instances of complementary opposition.

Indeed, in numerous cases the complementarity of two things

appears to consist in little more than the fact that their names are conjoined to form dyads in the lexicon of ceremonial language. Probably the majority of such dyads are 'synthetic' (see Fox 1971a: 248), that is, they derive from associations that are culturally specific or, at any rate, not universally valid; while in other instances the relationship between elements can be defined, from an analytical point of view, as one of synonymy, antithesis, or metonymy, and so on. As noted, however, in Rindi all such regularly paired components of ritual language are said to be distinguishable in terms of gender. Since this distinction governs binary relations of the most disparate kinds, therefore, it is hereby suggested that for the Rindi 'male' and 'female' might ultimately represent the simple fact of duality itself. In this regard, we might further recall the term *papa* ('complement', 'partner, counterpart', 'competitor, enemy', etc.), a word that is applied to a host of binary relations which, though logically diverse, all share in common the features of dualism and asymmetry.

Dualism is also implicit in the ritual use of even numbers, which, in accordance with the complementarity of binary symbols in general, represent completeness and an articulated unity. In certain instances, moreover, by way of a contextually specific application of the distinction of male and female, a dualistically conceived whole is itself complemented by another element similarly articulated, thus producing a higher unity and, at the same time, giving rise to four-fold and sometimes, by a further process of division or combination, eight-fold classifications. This pattern, which is most clearly revealed in the classification of alliance prestations and parts of the house, is therefore consistent with the particular value placed on four and even multiples of four, and with the symbolic equivalence and interchangeability of these numbers in various contexts. While this particular mode of classification by gender is by no means evident in every instance in which these numerical symbols occur, it should further be recalled that a total of four is often more specifically conceived as a conjunction of two pairs. It seems, then, that for the Rindi unity is an aspect of duality, and duality a necessary attribute of unity.¹

Dyadic relations can also be discerned where other totals, especially three and five, are more apparent. Thus a unity is sometimes represented by a centre distinguished from a subordinate periphery, which the former symbolically unites with itself. The periphery may then be divided into two parts, e.g., the two outer sections of the

village separated by the central section, or into four, as in the case of the four *tulaku paraingu* of a noble clan or the four *ratu* grouped around the uninhabited house in Umalulu. As I have argued, however, in the village the two outer sections form a unity which complements the centre, while in the other cases just cited the peripheral four and the central one are not so much complementary as fundamentally equivalent. (Moreover, since in this instance the four thus constitute an articulated representation of the superordinate centre, it appears significant that this latter entity, being in itself unarticulated, is characterized as immobile and inactive.) With these configurations, therefore, there is no mention of the numbers three and five; they are not relevant attributes of the relations in question.² In contrast, where uneven totals are expressly enjoined they seem always to figure as symbols of incompleteness and non-fulfilment.

In several contexts of Rindi ideology, paired categories display a dynamic aspect involving a unilateral and irreversible transfer of properties between the two ranked elements that proceeds from the superior to the inferior. Proper order is then defined by a rule enjoining 'movement to the right', and is typically founded upon the distinction of 'trunk' (*pingi*) and 'tip' (*kapuka*). As I have demonstrated, this pattern of ideas is entailed in the relation of wife-giver and wife-taker, a defining feature of the eastern Sumbanese social order, and in that of ancestors and descendants or, more generally, divinity and the mortal world. As is clear from the numerous instances in which something designated as a trunk or origin (*pingi, mata*) is identified as a source or focus of spiritual power (e.g., the *pingi* ends of house posts, which are regarded as places of tutelary spirit), what is transferred from trunk to tip in these cases is essentially the means to life and prosperity. This unilateral movement, however, is necessarily balanced by a transfer in the opposite direction of contrasting properties, notably certain kinds of material goods. Thus the same sorts of valuables that are given to wife-giving affines are presented as offerings, i.e., things given in return for divine protection and blessing, to various forms of spiritual beings.

As it concerns ultimate origins, one of the most important expressions of this complex of ideas is the notion of a conjunction and later separation of the two halves of the universe, the masculine sky and the feminine earth, which resulted in a disjunction between divinity and the mortal world and hence permitted the transfer of life, in the form of the deified first ancestors, to the earth. This event

is replicated in each generation: thus the male and female genitalia are symbolically equated with the two extremities of the cosmos, and the birth of a child is represented as an analogue of the arrival of the clan's first ancestor on Sumba from the Base of the Sky. In a wider context, however, the Base of the Sky figures specifically as an ultimate point of origin, which then stands in contrast to a more immediate and continuous source of life identified with vital fluids emanating from the opposite cosmological extremity, the Head of the Earth. These two complementary sources of being, then, suggest two aspects of divinity, one mostly regulatory and the other life-sustaining, and are further comparable to patrilineal ancestors and wife-giving affines respectively.

In accordance with the required unilaterality of the transfer of life, any inversion of the order in which this takes place results in its cessation, or in other words in death. Death is thus conceived of as a reversal of this process and as a return of spirit to its point of origin, which is divinity. As the mortal world is governed by a movement to the right, therefore, the world of the dead is thought to be ordered by the opposite rule, namely 'movement to the left'. Yet, from another point of view, life and death form necessary stages in a single cycle of being, a continuous process of degeneration and renewal, which involves the movement of spirit through various material and immaterial forms. This cycle is comparable, then, to the circulation of women (and hence the possibility of life) between groups entailed by the rules of marriage, and is most clearly expressed in the idea that, while mortals derive from immortal ancestors (*marapu*), after passing beyond death the former themselves become *marapu* and, by way of a further transformation, their own living descendants. Thus although for living mortals death is the antithesis of life, the two forms of existence ultimately unite to compose a dynamic whole; so that what from one perspective appear antipathetic are from another complementary.

Rindi ideas regarding the cycle of life and death can moreover be seen to parallel their representations of other temporal processes. While this is not the place to provide a full demonstration,³ it is useful to cite an example of the sort of correspondences that could be adduced in this regard. Thus certain prohibitions that are in force during the aforementioned *wula tua* ('revered months') — the annual period of restriction that intervenes between the wet and dry seasons (*ndau urangu* and *ndau wandu*), the two major divisions of the eastern

Sumbanese year — are the same as or similar to ones that apply while a corpse remains unburied and until the end of mourning. This, as well as other ideas concerning the wet and dry parts of the year themselves, suggests then that the wet season; the *wula tua*; and the dry season are conceived respectively as analogues of life; the transitional period during which the soul passes from the world of the living to the afterworld; and the state of death itself. As I indicated briefly in Chapter IX (Section 11), the Rindi classification of parts of the year exhibits a basic binary division that is conterminous with a partition into numerous phases which together form a single, oriented cycle of recurrent events; and these features also characterize their classification of parts of the lunar month and of the day and night. In these latter cases, moreover, the two major divisions of the periods in question — day and night and the waxing and waning moons — are expressly distinguished as male and female, and in various ways are associated with life and death respectively.

In Rindi, the process whereby the dead become life-giving spirit is further expressed in terms of a transformation of the 'hot' (*mbana*) into the 'cool' (*maringu*). As I have shown, these common Indonesian categories have a very wide range of applications in Rindi symbolism; and since 'coolness', despite its several different senses, generally denotes a desirable property, a great deal of their ritual life is concerned with obtaining this quality or with changing something hot into something cool. Another example of this transformation is the ritual cooling of new land, a symbolic act that further provides an especially clear instance of the concomitant readjustment of a boundary between the inside and the outside so as to effect an expansion of the former. This process, then, is analogous to the initiation of alliances with previously unrelated groups; and in both cases the aim is to secure new sources of life and prosperity.

As it pertains to relations between the generations, the cyclical conception of life and death in Rindi is further articulated by the idea of an equivalence between alternate genealogical (or, more exactly, terminological) levels and an opposition between adjacent ones. Members of the first ascending and second ascending levels are distinguished moreover in that, while both are givers of life, the former, particularly parents, bestow life in an immediate and material way, whereas the latter — by conferring upon an individual a name and hence an identity and destiny — represent by contrast a source of immaterial and mystical qualities. In this respect, then, the relation

of members of alternate generations reflects in microcosm the wider connexion between the deified first ancestors and currently living mortals. Indeed, it has been shown that these two relations appear sometimes to be equated or conflated in Rindi thought, so that a person's ancestral namesake is not always clearly distinguished from the clan's apical ancestor, or from God.

With regard to these same contrasts, in its positive aspect the relation between adjacent generations, especially parents and children, on the other hand, can be seen to parallel that of affines; for both relationships are represented in terms of a vital, unidirectional transfer of blood and flesh; and in ritual idioms, wife-giving and wife-taking affines are in fact spoken of as 'parents' and 'children'. However, it is important to stress that such resemblances and contrasts have no more than a contextual validity in Rindi symbolic thought. Thus, despite the similarities just noted, in contrast to agnates, wife-givers are represented mainly as a source of spiritual rather than material qualities; so in this respect they more closely resemble members of the second ascending genealogical level, in particular a person's ancestral namesake. In addition, while parents are undeniably providers of life to their children, the principle of opposition that governs certain facets of this relationship calls to mind the antithetical aspect of the relation of the living and the dead.⁴ Accordingly, the notion of the dead as givers of life (which by contrast derives from the idea of life and death as complementary states of existence) is evidently connected instead with the relation between alternate generations, and by extension with that between ancestors and descendants.

The alliance relation in Rindi thus appears to combine attributes otherwise associated with the relation of alternate genealogical levels and that of adjacent levels respectively. Indeed, like the Head of the Earth in contrast to the Base of the Sky, alliance is linked with a continuous transfer that involves the renewal of material as well as spiritual qualities. It follows, therefore, that the basic contrast between alliance and descent is not straightforwardly one between essence (or spirit) and substance, for the transfer of both properties is regulated, albeit in different ways, by both principles. Rather, the relation between these two defining features of the Rindi social order is perhaps best characterized as an opposition between (relatively) static form and dynamic process.

As noted, since a person may take the name of a forbear of either his mother's or his father's clan, the relation of alternate generations

involves ascendants in wife-giving lines as well as those in ego's own. Consistent with this feature is the absence of the distinction of alliance status in the second ascending and second descending levels of the relationship terminology. Since this distinction is clearly made in adjacent levels, however, the principle of alternation does not in any way compromise the requirement that ties of affinity be passed on from one generation to the next. The equivalence of alternate genealogical levels seems therefore to be a principle separate from alliance in the operation of the social order. In this respect, then, the ideological and, to some extent, terminological expression of the former principle in Rindi could be adduced as additional evidence that alternation is not incompatible with an asymmetric system of marriage (see Korn 1973:123).

Finally, it is worth pointing out how a pattern of relations analogous to that which concerns descent and alliance is discernible in the structure of the Rindi house, as described in Chapter I. First, by reference to the distinction of *pingi* and *kapuka*, adjacent building components that form parallel rows, such as the roof slats, are arranged inversely to one another, while in this regard alternate components are disposed identically. This provides, then, an exact correspondence to the order of relations found among members of different generations. Secondly, as one half of the slats thus 'move to the right', while the other half, by implication, 'move to the left', the arrangement appears further to parallel of opposition between the living and the dead. It should be recalled, however, that the Rindi do not recognize 'movement to the left' as an attribute of proper order in this, or indeed any, part of the house; so here alternation is evidently viewed as a principle distinct and separate from 'movement to the right' as it pertains to the arrangement of other parts of the building.

In this respect, then, the way parts of the house are physically ordered reproduces the pattern of ideas by means of which relations between the generations and the relation of alliance are articulated in the social system. The possibility of such concordance derives of course from an application of common principles and conceptual distinctions throughout a variety of areas of Rindi thought and conventional behaviour.

APPENDIX I

GENEALOGY OF THE RULERS OF RINDI

Umbu Lutungu — Eti Ndamungu ¹

Umbu Mbadi Wohangara

Umbu Karananja Pekuwali

Umbu Hiwa Ndapabeningu

Umbu Renggi Nggilinjuka

Umbu Nggaba Hungu

Umbu Nggala Lili Kaniparaingu

Umbu Kahumbu Nggiku

Umbu Nggala Lili Kaniparaingu ²

Umbu Hina Marumata (*alias* Borungu Kanàtaru) ³

Umbu Nggala Lili Kaniparaingu (*alias* Rara Lunggi)

Umbu Hapu Hambandima (*alias* Umbu Kandunu) ⁴

Umbu Wunggi Keimaraku (*alias* Umbu Kudu) ⁵

1. Founding ancestor of the clan Ana Mburungu.
2. First to move to Rindi and common ancestor of all current noble lineages of Ana Mburungu.
3. First government raja of Rindi.
4. Last government raja of Rindi (died December 1960).
5. Only son of the last government raja (born 1960).

APPENDIX II

DESCENT GROUPS IN RINDI: CURRENT SIZE *

	Males	Females	Total
1. Ana Kapu			
(Pala Mangili)	4	6	10
(Parai Pajurungu)	9	18	27
2. Ana Mawa	1	1	2
3. Ana Mburungu			
Uma Andungu	10	14	24
Uma Jangga	21	33	54**
Uma Kopi	6	6	12
Uma Kudu	9	10	19
Uma Penji	5	7	12
Uma Wara	6	7	13
Uma Kambata	12	16	28
4. Ana Mburungu Kanoru	8	11	19
5. Ana Mburungu Kalindingu	1	1	2
6. Ana Nggela	38	26	64
7. Dai Ndipi	25	27	52
8. Halopi	7	11	18
9. Hiringu	11	12	23
10. Kaburu	27	24	51
11. Kadumbulu	1	1	2
12. Kamandalorangu	6	1	7
13. Kanatangu (Ana Maeri)	71	94	165
14. Kanilu	39	41	80
15. Karambu			
(Anda Kapeta)	7	5	12
(Kahili)	13	14	27

	Males	Females	Total
16. Karindingu			
(Kalihi)	9	9	18
(Rànga)	7	5	12
(Reti Mbàlaru)	17	21	38
17. Katinahu	16	22	38
18. Kawata	1	3	4
19. Kihi	3	5	8
20. Kurungu	12	11	23
21. Lenggitu	3	6	9
22. Luku Tana			
(Kayuri)	12	15	27
(Kamala Wataru)	10	9	19
(Reti Pakadu)	6	5	11
23. Luku Walu	32	35	67
24. Mahora			
Uma Bokulu	8	7	15
Uma Pada Njara	26	26	52
25. Maleri	13	16	29
26. Marada Witu	39	43	82
27. Maritu	18	22	40
28. Matalu			
(Kanoru)	8	7	15
(Wai Kanabu)	23	13	36
29. Menggitu			
(Kabaru)	4	8	12
(Lai Lanjangu)	8	8	16
(Wai Kanabu)	16	21	37
30. Muru Uma	15	14	29
31. Mbara Dita	8	14	22
32. Mbara Papa	19	19	38
33. Pahada			
(Kabaru)	9	8	17
(Kalumbangu)	19	19	38
(Kayuri)	53	46	99
(Lai Lanjangu)	3	7	10
34. Pakilungu	9	8	17
35. Palamidu	6	7	13
36. Parai Tuwa	10	14	24

	Males	Females	Total
37. Ramba	15	10	25
38. Tarimbangu	16	18	34
39. Tatimba	12	18	30
40. Tidahu			
(Kabaru)	5	4	9
(Kalihi)	17	19	36
41. Uma Paterangu	6	5	11
42. Wanga	12	11	23
43. Watu Pelitu			
(Kayuri)	13	10	23
(Mbuu)	2	6	8
44. Wiki			
(Kanoru)	2	5	7
(Rànga)	22	21	43
Total	901	986	1,887

* This includes only free members of these descent groups; slaves are listed in Appendix III. The names in brackets refer to the villages in which independent lineages recognizing the same clan name and ancestor (but having separate ancestral houses) are centred. 'Uma', in indented designations, indicates a named lineage of a clan.

** The figures for Uma Jangga include two elderly daughters of a Kambera nobleman, of the clan Parai Karaha, who moved to Rindi upon marrying an Uma Jangga noblewoman and subsequently remained. Neither of these women has married, and for all practical purposes they are therefore counted as members of the Uma Jangga nobility.

APPENDIX III

**CURRENT NUMBER OF ATA (SLAVES)
ATTACHED TO RINDI CLANS AND LINEAGES**

Clan/Lineage Name	Number of <i>Ata</i>	Number of Free Members
(a) Nobles		
Ana Mburungu		
Uma Andungu	201	24
Uma Jangga	267	54
Uma Kopi	110	12
Uma Kudu	103	19
Uma Penji	478	12
Uma Wara	39	13
Uma Kikiru *	4	---
Total	1,202	134
(b) Commoners		
Ana Kapu (Parai Pajurungu)	4	27
Ana Mburungu		
Uma Kambata	33	28
Ana Nggela	13	64
Dai Ndipi	10	52
Kanatangu	10	165
Karambu (Kalihi)	3	27
Katinahu	9	38
Mahora		
Uma Pada Njara	17	52
Ramba	1	25
Tarimbangu	8	34
Wanga	3	23
Total	111	535
Grand Total	1,313	669

* Uma Kikiru consists entirely of *ata*. Their distinct lineage name refers to a ceremonial function they maintain on behalf of the Ana Mburungu nobility (see Chapter VIII, Section 5).

NOTES

INTRODUCTION

- 1 *Huri* is roughly equivalent to the Indonesian word *adat* and can variously be translated as 'culture', 'way of life', 'custom', 'religion', 'rite', and, with regard to the individual, as 'demeanour', 'behaviour', and 'manners'. Kapita (1974) gives as one gloss of *huri* the Indonesian word *suri*, 'shuttle comb on a weaving loom', but I never heard the term used in this specific sense in Rindi. It is also not clear whether the two words are cognate. A more likely derivation of *huri* seems to be the Austronesian root **hudip*, 'life, to be alive' (Dempwolff 1938:65; see also eastern Sumbanese *luri*, 'life, to be alive').
- 2 By 'eastern Sumba' I refer throughout to the larger part of the island which previous authors have distinguished on linguistic and cultural grounds (see Section 6 below). The name East Sumba, then, is reserved for the modern administrative district or 'regency' (*kabupaten*) of Sumba Timur, which covers a slightly more restricted area.
- 3 In Wawewa (western Sumba) the form is Zumba. The first unambiguous Dutch reference to the island as Sumba (Soemba) appears to be that found in a report of 1780 by van Hogendorp (*Encyclopaedie van Nederlandsch-Indië* 1921-IV:4). Before this time it was known to the Dutch as Sandel Bosch Eyland (Sandalwood Island) and earlier by the Javanese (ultimately Sanskrit) name Cendana (Sandalwood). Over the last two centuries at any rate, however, this tree has not grown in abundance on Sumba.
- 4 All place names mentioned in the Introduction are found in the Maps. It should be noted that in most earlier Dutch sources Umalulu is given as Melolo, the Savunese version of the name; but this specifically refers to the Savunese colony located on the coast within the territory of Umalulu.
- 5 Rindi has variously been transcribed as Rende, Rendeh, Rendih, Rendi, and La Rendi (or Larendi; *la* is the general preposition of place). Since *rendi* actually means 'duck (waterfowl)', this form is not only inaccurate but also potentially misleading.
- 6 Sumba lies southwest of Flores and southeast of Sumbawa, between 119°3' and 120°50' east longitude and 9°15' and 10°20' south latitude.
- 7 The reader interested in the known history of Sumba should consult de Roo van Alderwerelt (1906), Wielenga (1926a, 1949, and articles published in the missionary journal *De Macedoniër* between 1916 and 1918), and Kapita (1976b).
- 8 The demand for horses, however, also caused a decline in the export of slaves; since the rulers were amply provided with income from the sale of livestock, they were no longer so inclined to sell slaves (Anon. 1855:299). Indeed, according to de Roo (1890:582), during this time Endenese slavers

- began to import slaves to Sumba from Manggarai and the Endenese interior.
- 9 The proportion of buffalo in East Sumba also decreased between 1941 and 1973, from 100:538 to 100:715. These ratios are computed from figures provided by Wielenga (1949:40) and *Nusa Tenggara Timur dalam Angka Tahun 1973*, the annual report of the Census Bureau in Kupang (published 1974). Unless otherwise indicated, all figures concerning East Sumba cited in the remainder of the Introduction are taken from this latter source.
 - 10 The founding ancestor of the Patawangu noble clan Lamuru is said to have taken a wife from Ende, as is Umbu Endalu, the principal ancestral figure in Umalulu.
 - 11 Accounts differed as to where Ana Mburungu resided prior to this. According to one version, however, they lived in Paliti Pangadu Njongu, in the vicinity of Cape Sasar (Haharu), which agrees with the report that they had previously taken wives from this place for some three generations. The earliest ancestor of the clan, though, settled at the mouth of the Kambaniru river (Pandawai) in Kambera, not far from Parai Kakundu, where he landed on Sumba.
 - 12 Curiously, and contrary to all I heard in Rindi, Kapita (1976b:124-5), in a brief account of the history of Karindingu and Ana Mburungu, states that the feud between these two clans and the evacuation of Parai Kakundu occurred before Ana Mburungu was attacked by the Endenese. It was this latter event, he says, that caused them to move to southeastern Sumba.
 - 13 It will be noted that prior to this Ana Mburungu was a wife-giver of the clan Palai Malamba. The question of the kinds of groups involved in marriage exchange is discussed in Chapter XII (Section 3).
 - 14 Curiously, Roos (1872:3), who generally displays a good knowledge of eastern Sumbanese affairs during this time, gives Ana Mburungu ('anaboroeng') as the clan of the ruler of 'Melolo' (he clearly refers here to Umalulu), though he mentions Rindi elsewhere in his report.
 - 15 These included the clans Karopangu (after which the village was named), Marai, Watu Nggoda, and Kanjangi. These names are found in a list of Mangili clans included in an anonymous report of 1933 (Anon. 1933:7-8).
 - 16 He refers here to the former Dutch administrative district which was separate from Central Sumba. With regard to the entire eastern region, this distinction unequivocally belongs to the ruler of Lewa.
 - 17 By all indications this man lived to a very great age. Though he is said to have been adult when his father founded Parai Yawangu, in 1912 the Dutch appointed him as native administrator of Rindi. He died in 1919. His son and successor, Nggala Lili (alias Rara Lunggi, 'Red Hair'), seems also to have enjoyed a long life, since in 1925 he was declared too old and deaf to administer the district unaided (Kapita 1976b:54). He was replaced by his own son and former deputy in 1932, and died about 1950. Longevity seems to be generally characteristic of the Rindi nobility. A daughter of Hina Marumata, the fifth child of his fourth wife, was still living in 1976; she was then already in her nineties.
 - 18 *Zelfbestuur* has the sense of 'self-government' or 'home rule'. There were 15 smaller territories annexed to the nine sub-departments. These were represented by native 'assistant administrators' (Du. *onderbestuurders*).
 - 19 In respect of demography, East Sumba can usefully be contrasted with the West-Sumba regency (Sumba Barat), which in 1971 had a population of 187,676; a density of 40.9 per km. sq.; and an annual rate of increase (from 1961) of 2.01 per cent. The last two figures for the province as a whole were respectively 47.6 per km. sq. and 1.68 per cent.

- 20 *Desa* boundaries are drawn in part so as to accommodate a certain size of population. The ideal upper and lower limits, I was informed, are 2,000 and 500 persons respectively.
- 21 This figure derives from the registers of inhabitants of the six *desa* (which unfortunately were not always complete), electoral lists that were being compiled for the 1977 national election, and our own records of clan and village composition.
- 22 The Savunese reside in several independent settlements near the coast in Kayuri and Haikatapu, while the majority of Endenese are found in the coastal village of Tapilu, also in Haikatapu. Significantly, the *desa* with by far the lowest non-Rindi population is *desa* Rindi, which lies in the centre of the traditional domain.
- 23 It is worth stressing that this figure refers to residence. Thus it does not accord with those given in Appendices II and III, which concern only descent group affiliation. One factor accounting for the difference is a pattern of (temporary) residence with wife-giving affines in other domains.
- 24 Since *hâmu*, 'good', also has the connotation of 'indigenous', sorghum is thus called 'indigenous maize', which suggests that it was the staple before the introduction of maize. Accordingly, maize (*wataru*) in eastern Sumba is sometimes specified as *wataru jawa*, 'foreign *wataru*'. Fox (1977:75) notes the same usages on Roti and Savu. It is possibly due to its relatively recent foreign origin, then, that maize may not be used in offerings or given to guests in eastern Sumba (Barnes 1974:48 notes a similar prohibition in Kédang); only rice (*uhu*) may be so used. Maize does have some uses in Rindi ritual, however. It will be noted that millet (*uhu kani*) is apparently named after rice; but *uhu* in a number of contexts also has the general sense of 'food', e.g., *uhu njara*, 'horse fodder'.
- 25 At present, at any rate, Fox's statement (1977:21) that nearly all eastern Sumbanese are swidden agriculturalists is therefore questionable.
- 26 This is called *wataru pakarabangu*, from *karaba*, 'trough', or *wataru paman-gahungu*, 'watered, sprinkled maize', after the practice of planting the seeds in depressions in the ground which are then daily filled with water brought from the river in lontar leaf buckets.
- 27 Kruyt (1922:573) describes the dog as the sacrificial animal par excellence on Sumba. At the same time, though, he notes that in the eastern domains the livers of these animals are not used in augury and that it is forbidden to offer dog meat to the ancestors; but he also says that the meat is generally eaten there.
- 28 Though the eastern Sumbanese are poor seamen and rarely venture far from shore, they have quite an extensive classification of fish and other aquatic creatures; from Kapita's dictionary (1974) and my own notes I would estimate that they distinguish well over 100 varieties. I also counted 48 names of wild birds, 16 names of reptiles (including 11 snakes), 36 insects, and 14 wild mammals, almost none of which are of any economic significance.
- 29 Products exported from Sumba during the eighteenth and nineteenth centuries included yellow dye wood (*ai iju*), ebony, satinwood and sandalwood, rope, tortoise shell, edible birds' nests, and some rice and maize. Imports included cloth, silks, ivory, beads, gongs, iron ware, copper wire and other copper ware, crockery, and rice (Anon. 1853:50; Anon. 1855:300-304; Kapita 1976b: 18).
- 30 The loin-cloth, measuring about 1 by 2.5 metres, reaches to just above the knees, while one end is left to hang lower at the front. This manner of wearing the cloth seems to be peculiarly Sumbanese and now serves as an

- important sign of Sumbanese identity. Significantly, as the lower hanging end — once or twice jokingly referred to as a ‘tail’ — can be tucked between the legs, it is well adapted to riding.
- 31 Formerly, poor people wore clothing made from the pounded bark of the *kambala* tree (*Broussonetia papyrifera*), but this is no longer seen in Rindi. Though some cotton is grown in eastern Sumba, at present much cotton for weaving is purchased from merchants. The Rindi no longer weave plain, undecorated textiles.
 - 32 The eastern Sumbanese language area also includes the dialects of Mamboru, Anakalangu, and Wanukaka (see Wielenga 1917, Onvlee 1973), which districts administratively form part of West Sumba. Besides the western Sumbanese languages, with which it shows by far the greatest affinity, eastern Sumbanese is most closely related to the languages of Bima, Savu, and Manggarai.
 - 33 By ‘Indonesian’ or ‘the Indonesian language’ I refer throughout to Bahasa Indonesia, the Malay-based national language. ‘Indonesian languages’, on the other hand, denotes all Austronesian languages spoken in the Indonesian archipelago.
 - 34 See also *dalū*, ‘inside’, and *wawa*, ‘below’, which in the living language are often contracted to *daa* and *waa*.
 - 35 Following the example of Kapita and Onvlee, I have conjoined separable affixes and various forms of the personal pronoun with the nominal or verbal root. The nominative pronoun particles, however, are separated from the verb with a hyphen to distinguish them from the singular and plural definite articles. The relative pronoun *ma* is also joined to the root. See, e.g., *na lakuna*, ‘the going of his’, i.e., ‘his going’ (also ‘behaviour’); *malaku*, ‘(that) which goes’; *ma-laku*, ‘we (excl.) go’.
 - 36 Fox (1977:87) notes a marked contrast in this respect between the Savunese and the Rotinese. The latter, he says, ‘... can talk a good ceremony but they are rarely concerned with actually performing one...’, while ‘... Savunese rituals are dramatic performances that require little verbal accompaniment...’. In this regard, then, it is clear that the eastern Sumbanese resemble more closely the Rotinese. Their language, however, is more closely related to that of the Savunese.
 - 37 We made many visits during this time to the Umalulu district and in November 1975 resided there for a month, while in May 1976 we spent nearly another month visiting Kapunduku, Nàpu, and Kanatangu in the Haharu region on Sumba’s north coast. Our stay on the island was broken for three weeks in December 1975 when we travelled to Kupang to renew our residence permits.
 - 38 Despite their vigilance and ours, in the course of two years we had three horses and a sum of money stolen from our house.
 - 39 The only items of equipment we took to the field were a camera and an inexpensive tape-recorder, which I used mainly to record the ritual language. Due to the damp conditions of one part of the year and the heat and dust of the other, the latter quickly deteriorated and was useless after a year; but fortunately in August 1976 I managed to obtain another. Our camera also failed us on several occasions.
 - 40 Though from direct experience I can only speak for the Rindi, most of my comments here seem to apply to the eastern Sumbanese as a whole.
 - 41 Early Dutch writers (e.g., Humme 1876) also described the Sumbanese as timid and cowardly. Indeed, they do seem to approach many things with a noticeable trepidation, and, as they themselves note, in this respect they differ

- markedly from the Suvanese. Another self-acknowledged quality, and in some ways a general principle of their behaviour, which I might mention here is their general reluctance to engage in any activity at which they feel themselves to be less than proficient. Accordingly, doing something improperly or less than adequately is very much disparaged.
- 42 Because of mutual distrust between elderly experts in custom, and an anxiety about disclosing too much of their own knowledge to others, I therefore found I could usually discuss such matters only with one or a very small number of persons at a time.
- 43 From the number of cases I heard about, suicide seems not to be uncommon in eastern Sumba (see also Wielenga 1913:38n). Two persons of my acquaintance had suffered permanent damage to the throat (by the knife and the rope respectively) from abortive suicide attempts. Vain love affairs and wounded pride are reputedly the usual motives, though I also heard of a strange case where two women had simultaneously hanged themselves, for which no motive could be fathomed.

CHAPTER I

- 1 I shall hereafter retain this gloss to refer to these houses. 'Residential house' would arguably be another possibility; but ancestral houses are also places of residence. The distinction of 'cool' and its opposite, 'hot' (*mbana*), with regard to houses will be further discussed later in the chapter.
- 2 Fox (1971b:221) notes a parallel use in Rotinese of the terms for 'mother' and 'child' to distinguish large and small objects of the same kind.
- 3 The expression *bai ahu* (*ahu* is 'dog') can thus mean either 'bitch' or 'damned, blasted dog'.
- 4 *Uratu*, like the related *ura*, further means 'sinew, nerve, vein' (Kapita 1974; see Ind. *urat*); *ura* also refers to the entrails of a fowl used as an augury.
- 5 In his Kambera dictionary (1974) Kapita gives *lambanapu* as 'four beams that lie atop the four corners of the house'.
- 6 As I shall elaborate in Chapter VI, the *kalotu* at the centre of the front of the house also provides a means of access to divinity. Such is clearly the case also with the main house post, *kambaniru uratungu*, in which respect it is worth recalling that one meaning of *uratu* is 'sinew'.
- 7 In order to secure the lower ends of the spars (*kiri huku*), the bottommost row of slats, called *tipa ru*, 'supports of the leaves' (i.e., the eaves, *ru kawindu*), which are rather stouter than the others, is found first. The row directly above is called the *talaru winingu*, 'hidden slats'. Alternative names for the *tipa ru* and *talaru winingu* respectively are *katiku witu* 'head of the thatch', and *bānggi witu*, 'waist of the thatch'. The third and higher rows are then called the *kiku witu*, 'tails of the thatch'.
- 8 The expression *karimbua uma*, 'house buffalo', which I only ever heard once or twice, seems to be another name for this part of the house, though it might also refer to the shape of the entire top of the peak.
- 9 The hearth is supported by piles placed inside the four main house posts. The base (*kabamba ai*) consists of two layers of banana trunk bast laid lengthwise and breadthwise on top of a foundation of planks. A layer of earth is then placed over the bast, dampened, and tamped down so it becomes firm. The banana bast (*taraba kaluu*) may here have the further symbolic function of keeping the hearth 'cool' (see Chapter VIII).
- 10 The entire length of the stem or trunk, on the other hand, is called the *pola*,

- which term is occasionally used as an equivalent of *pingi*. A tree is *pingi ai*, literally 'wooden trunk' (cf. Ind. *pohon kayu*); and *pingi* is also used to refer to particular sorts of trees, e.g., *pingi kokuru*, 'coconut tree'.
- 11 Cunningham (1973:212) describes multiples of four among the Atoni of Timor as the 'numerical expression of unity'.
 - 12 Onvlee (1949:452) similarly notes, with reference to prestations, that totals of eight can be reduced to four or two.
 - 13 Although the Rindi never commented on this feature, it is possibly significant that the totals of the two, or in the largest house, three outer series of house posts, which number 12, 20, and 28 respectively (see Fig. 1), regularly increase by an increment of eight. In most houses, therefore, the posts comprise a recognized total of 36, which could perhaps be construed as four central posts plus 32, or four times eight, outer posts. In the largest house, on the other hand, the total is 64 (i.e., 36 plus 28 *wihi wei* posts), or eight times eight, which would appear to be a preeminent expression of completeness.
 - 14 The total number of spars in the various standard sizes of houses in Rindi were 76, 52, 44 and 36. Thus the numbers between the two corner spars on each of the longer sides were respectively 19, 13, 11, and 9, and on each of the shorter sides 17, 11, 9, and 7.
 - 15 That the shorter and longer sides might yet be associated with even and uneven numbers, however, is suggested by a description I was given of the ceremony for expelling incest (see Chapter XVI). Briefly, for this purpose, I was told, four men pound and pelt the walls of the house with stones: those at the front and back each carry two stones while those at the longer sides each carry three stones.
 - 16 The grooves are said to facilitate communication with the clan ancestor (see also Adams 1974:336), in which respect an informant in Nàpu mentioned the phrases 'descend by the seven paths, ascend by the eight paths (*puru la pisu lara, hai la walu lara*). Uneven totals, particularly seven and three, are also prescribed for certain parts of the house in western Sumba, though according to Mr. Joel Kuipers (personal communication, 1979), who has recently done fieldwork in this region, these numbers are there regarded as an expression of completion.
 - 17 In ritual language these two surfaces are designated as the 'platform above' (*ladi dita*) and the 'platform below' (*ladi wawa*) respectively.
 - 18 This is further indicated by the position of the yard altar (*katoda kawindu*, see Chapter VI), which, it is said, should be placed to the right side of the building. It is, in fact, placed near the right front corner (see Plate 1b).
 - 19 The Rindi also distinguish the two cooking places as the *epi mini* and *epi kawini*, 'male' and 'female' fires.
 - 20 The women thus cook the rice while the men (on the occasion of major sacrifices at any rate) cook the meat. Interestingly, Clamagirand (1975:150) records the same division of labour among the Ema of Timor. The two parts of a food offering — the meat and the rice — might therefore be distinguished as male and female portions respectively.
 - 21 Among the Ema of Central Timor, this rule is enforced in respect of that part of the house called the 'big platform' (Clamagirand 1975:20), which in most respects, including its name, appears to correspond to the *kaheli bokulu* ('big floor') in Rindi.
 - 22 There is, however, one house in Rindi where women are strictly forbidden to enter the right section. This is the Uma Ndewa, a house of the noble clan given over entirely to major rites that concern the powers called *ndewapahomba* (see Chapter IV). Referring to eastern Sumba in general, Noot-

- boom (1940:49-50) on the other hand says that wives and their agnatic relatives are prohibited from entering the right side of the house, but this is not the case in Rindi.
- 23 According to van Dijk's (1939a:504) description, in the Laura house (western Sumba), the 'men's door' is located at the front of the house and the women's at the back, on the left side. I might also mention in this respect that one informant in Rindi thought that 'male' and 'female posts' referred to the ones at the front and back of the hearth rather than those on the right and left sides.
 - 24 Recalling names given to the four central house posts (see Section 3 above), it is apparent that all four quarters of the house have some religious value or connexion with the cult of the ancestor; so in this respect the distinction of spiritual and temporal is actually a relative one. Even the post in the left back corner (and hence this area in general), named after the activity of feeding pigs and chickens, can be seen to have ritual significance, since these animals serve as sacrifices made to the ancestor and other forms of spirit.
 - 25 The connexion between the peak and the right front corner, as well as the symbolic masculinity of these two parts of the house, is further shown by the expression 'horns of the house, pole that supports the clan (or corner)', (*kadu uma, tandai kabihu*). In ritual speech, these phrases, which specifically denote the structure at the top of the peak and the principal house post (*kambaniru uratungu*), are used to refer to male offspring, who will perpetuate the patrilineal group and its name.
 - 26 With reference to humans, 'tail' denotes the base of the spine.
 - 27 In ritual language, the back and front of the house are often called simply the *ulu* and the *yàba*. *Ulu*, 'hilt, handle (of a knife)' is a reflex of Proto-Austronesian **ulu*, 'head', 'beginning, opening' (Dempwolff 1938:162). Interestingly, *mata*, 'eye, source, focus, etc.', as in *mata yàba*, the front of the house, also has this sense; so it seems that the front and back of a building may thus be conceived as 'beginnings' of different kinds. A parallel case is found in ideas concerning certain instances of 'head' (*katiku*) and 'base' (*kiri*) (see Chapter III). With regard to the evidently analogous conceptions of right and left and front and back, moreover, it would be useful to know whether *kiri*, denoting the back of the building, were not related to the Indonesian word *kiri*, 'left (side)'.
 - 28 *Hambeli* is related to *beli*, 'to turn around', 'to return, go back'. The polite term for defecation is *pahambelingu*, 'to make place outside'. A similar usage is found in Rotinese, where a derivative of *deak*, 'outside', 'in back of, behind', is also used in this sense (Fox 1973:345).
 - 29 The term *mangu umangu*, 'possessor, occupant of a house', while otherwise referring to all the inhabitants, or to the principal (male) householder, was thus also once said to apply specifically to the women of the house. Similarly, in an unpublished report on the Umalulu district (Anon. 1947:2), the phrase is given as a term for the principal householder's chief wife, and so is translated as 'mistress of the house'.
 - 30 In ritual language 'chicken' (*manu*) and 'pig' (*wei*), and 'horse' (*njara*) and 'buffalo' (*karimbua*) are thus regularly conjoined to form dyadic pairs, which are used to express feminine and masculine values respectively. Though a man can correctly state that pigs or domestic fowls raised by his wife or daughter are his own, moreover, in a more general sense these animals are said to be 'owned, possessed' (*mangungu*) by women.
 - 31 The exceptional instances are the funeral, and, to a lesser extent, one form of contracting a marriage, when the women of the guest group occupy the

- right front quarter of the building (see Chapters IX and XVIII). Especially in the case of the funeral, this arrangement provides one of numerous instances of ritual inversion.
- 32 This, of course, is a widespread symbolic contrast in Indonesia; and to cite all the relevant comparative references would require far more space than is available here.
- 33 As I shall later show, in this wider framework, as in the internal order of the house, 'hot' denotes something imbued with spiritual power. Hence there is a distinction to be drawn between symbolically masculine spirits that are beneficent and symbolically feminine spirits that are mostly maleficent.
- 34 Another term that describes an ancestral house is thus *uma pingi*, 'trunk house'; see also *pingi rama*, 'beginning of the work', which denotes a person who first cultivated a plot of land.

CHAPTER II

- 1 That the primary sense of *paraingu* is 'village' is suggested by the appearance of this term (usually contracted to *parai*) in the names of two lesser villages in Rindi: Parai Kahembi and Parai Pajurungu. These settlements, however, are never referred to generically as *paraingu*.
- 2 These clans are Karambu, Tidahu, Uma Paterangu, and Luka Tana. The first three have since relocated their houses further upstream in the Kalihi area. Since I shall later discuss quadripartition in respect of clans (see Chapters XI and XII), it is well to mention here that these groups do not formally make up a set of four in the ways I shall describe; nor are their ritual functions complementary. Their number, therefore, appears to be incidental.
- 3 Similarly, 'nobility of another river' (*maramba hau luku*) is sometimes used in place of 'nobility of another domain' (*maramba hau tana/paraingu*). Another example of the regular conjunction of 'land' and 'river' in parallel speech is 'the land, the place of my birth, the river the place of my growth' (*tana ngia padedinggu, luku ngia patumbunggu*).
- 4 The disappearance of the cactus, I was told, was hastened by a plant epidemic which occurred in the late nineteen-forties. Before this time many villages in Rindi were enclosed with cactus hedges.
- 5 I refer here to Parai Wunga, the principal village of Nāpu, which still contains the ancestral houses of most of the clans resident in this domain. Although for most of the year one must journey for two hours to obtain water, when I visited the village in 1976 I found nearly all the houses there had been rebuilt following a major fire of a few years earlier.
- 6 There are, however, a few settlements considered 'minor villages' which do contain graves, namely, those inhabited entirely by slaves of the noble clan, who do not have ancestral houses of their own. The nobility themselves, and certain of their slaves of higher standing, on the other hand, are always buried in the chief village.
- 7 The phrase can also refer to small, roughly made, single houses, called 'field houses' (*uma la woka*) or 'guarding houses' (*uma dai*) situated within the bounds of cultivated land. But while some dwellings of this sort are occupied the year round, they do not physically form part of anything that could be called a village (*kotaku*).
- 8 Because of the close association between the chief village and the nobility in Rindi, *la paraingu*, 'in (or 'of) the chief village' is a common way of refer-

- ring to the nobles. The remainder of the population, both commoners and slaves, are then referred to as *tan la woka*, 'people in (or 'of') the fields'.
- 9 Similarly, while the rites might further be repeated, on a lesser scale, in minor villages, it is sufficient, I was told, to carry them out only in the major villages, since the protection these rites secure extends to all members of clans which have ancestral houses in the major village, regardless of their usual place of residence.
 - 10 In a few cases of villages named in this way, two or more villages incidentally share the same name. There are thus three distinct villages in Rindi called Jàriku, 'Citrus Fruit Tree'.
 - 11 The name was changed to Yawangu, I was told, in order better to suit it to the rapid speech of ritual language. But this I find unconvincing, and it is possibly more relevant that Wawangu, as it connotes subordination or low status, appears rather ill-suited to the name of the principal seat of a noble clan which, in its own estimation at any rate, is among the highest ranking, if not the highest ranking, in the whole of Sumba.
 - 12 Though it may not always be apparent, this is how the Rindi in fact conceive the shape of the village; and this seems to be the case in other parts of eastern Sumba as well. Adams's (1974:328) description of the village as 'oval shaped' is thus less than accurate, at least insofar as this is meant to apply to eastern Sumba as a whole.
 - 13 *Rumba* is 'grass', 'weeds', and '(small) plants'. Among cultivated species, only leafy green vegetables are named as *rumba*, or, more exactly, *rii rumba* (*rii* can here be translated as 'vegetable' or 'side dish'). Significantly, the designation is used somewhat pejoratively; and, indeed, the Rindi consider these the most inferior variety of food.
 - 14 According to myth, wild chickens and pigs derive from domesticated counterparts brought to Sumba by the first ancestors and placed in pens. There were originally eight pigs and eight chickens. Those that became wild descend from a member of each species which escaped from its enclosure and fled into the forests and long grass (*rumba*). It seems, therefore, that the Rindi do not think of wildness as a natural or inherent state, but as one that derives from a breach of the bounds of culture and contact with the outside.
 - 15 While the top stones of some graves are perfectly rectangular, many have the four corners cut off, thus, significantly perhaps, producing eight lateral faces. Not far from Parai Yawangu, in an uninhabited spot, however, there were two old graves which were pentagonal in shape, the points facing towards the setting sun, which as I shall later discuss is the prescribed orientation. The Rindi told me that it was once the custom to place all graves outside the village. At present, though, they are always placed inside.
 - 16 The rectangular graves are thus disposed in the same way as the houses in Rindi. (In Nàpu and Kapunduku, where it is the longer sides of the buildings that run parallel to the longer sides of the village, the grave stones are also arranged in the same way as the houses.) It seems relevant, therefore, that the Rindi regard graves as the houses of the dead; in Umalulu some tombs have recently been constructed, from stone and cement, exactly in the form of peaked houses. In ritual speech, a grave is called 'a house that does not rot, a floor that does not break' (*uma mandamobu, kaheli mandambata*).
 - 17 Wielenga (1910a:74) mentions heavy folding 'doors' hewn from planks 10 cm. thick. According to ten Kate (1894:579), one entrance to the chief village in Rindi was formerly decorated with two roughly carved human figures, one male and one female, of the sort found on decorated textiles. These apparently disappeared long ago, and I never heard them mentioned.

- 18 The upstream and downstream gates are thus also known as the *pindu kambata* and *pindu kiku*.
- 19 Although Kapita (1974) gives *kamuri* as Indonesian *kemudi*, with which it is cognate, and this latter term can mean 'rudder', in eastern Sumba the actual rudder of a vessel is called the *ulingu*.
- 20 At present the place of the 'skull post' is marked by a stone slab set into the ground. With regard to my previous remarks concerning the associations of centre and periphery, it seems significant that this was described as a 'hot stone' (*watu moana*); it must therefore not be stepped on, walked over, or touched.
- 21 The two rows, or sides of the village are thus also called the *làdu wawa* and *làdu dita*, 'sun below, going down' and 'sun above, coming up', respectively. Since these two terms resemble *ladi wawa* and *ladi dita*, which, as noted, refer to the upper and lower parts of a house, it is well to stress that *làdu*, a dialectical variant of Kambera (and Rindi) *lodu*, is 'sun' (see also Kapita 1976b:183) and thus apparently unrelated to *ladi*, 'platform'.
- 22 The consequences were this to happen were expressed with the phrase *na pahoba kalada na lodu*, which perhaps means the spar would put in its mouth (*pahoba*) the tongue (or uvula) (*kalada*) of the sun (*lodu*); but as the grammar does not make this clear, it may be the sun which is the subject of the action. My informant could not explain the meaning of the phrase (which he had only heard from his father) or the implications of the event. Presumably, though, it has something to do with the undesirable effects of the sun's heat.
- 23 As was pointed out to me, when building a house one can usually take as a guide in this respect the disposition of adjoining houses or one that formerly occupied the site, as indicated by the slightly raised foundation of earth encircled by a drainage channel.
- 24 This arrangement also secures the marginal advantage of having the back of the house, through which women bring water into the building, on the river side of the village.

CHAPTER III

- 1 When the three particles are prefixed with *lai* (a very general preposition) *laini* indicates a place closer to the speaker than the hearer ('here'); *laina*, a place closer to the hearer ('there'); and *lainu*, a place some distance away to which neither is palpably or significantly closer ('there'). (There are other words translatable as 'here' and 'there', e.g. *yiahu*, *hiana*, *lai nàhu*, and *lai nàmu*; but this is not the place to discuss them.) Similarly, the three particles combine with *-na* and *-da*, the singular and plural possessive pronouns, to produce *nina/nida*, *nana/nada*, and *nuna/nuda*, which are to be translated as 'this'/'these' or 'that'/'those' (see also *yiana* and *yiada* for 'this' and 'these', used in an abstract or emphatic way).
- 2 *Niluru*, *naluru*, and *nuluru*, for example, would thus mean respectively 'here downstream', 'there downstream' (near the hearer), and 'there downstream' (further away), while *huluru* is simply 'downstream'.
- 3 The final *-ngu* of *welingu*, '(to come) from', in such constructions is transferred to the end of the direction word.
- 4 Another example of this practice is *hakawita*, from *hau*, 'one', and *kawita*, 'to split (in two)', which indicates one of two semi-globular objects such as plaited bowls and coconut shell vessels. Two items of this sort are then called *hakawori*, from *kawori*, 'round, whole'; thus three would be counted

- as *hakawori hakawita*, 'one round (i.e., two) and one half (i.e., one)'.
 5 The difference between *hapapa* and *hupapa* is grammatical. Thus one says *la hapapa luku*, 'on the other side of the river', but *hupapa la kotaku* 'over in the village (which lies on the other side, e.g., of a river)'.
 6 An undifferentiated lateral term is used as a direction indicator in Kédang (see Barnes 1974:85).
 7 A division of this sort is also found on Roti (Fox 1973:356).
 8 The major rivers, for example, are said to be reflections of the Milky Way, called *londa wai*, 'water channel', in Rindi, and in other parts of eastern Sumba *luku mbaku*, 'river of the erne'.
 9 In the Wawewa language of western Sumba, accordingly, the eastern Sumbanese are called *ata bondo*, 'the people above' (Kapita 1976a:47).
 10 Variants of Indonesian *timur* and *barat* are commonly encountered in Austronesian languages as the words for 'east' and 'west'. Eastern Sumbanese, too, has the cognates *timiru* and *waratu*; but these are employed only in ritual language, as the names of the prevailing winds of the east and west monsoons.
 11 Graves, on the other hand, might indeed be said to be oriented to the head and tail of the island, since they are always placed to face towards the setting sun, which is *wawa*, 'down'.
 12 It might also be considered whether *lua* is not related by metathesis to such direction words as Manggarai *lau* (Verheijen 1951:37), Ngaju *laut*, 'seawards', and Javanese *lor*, 'north', all of which are cognates of Austronesian **la'ud*, 'sea' (Dempwolff 1938:93). The way in which *lua* is used at present, however, does not clearly support this.
 13 Indeed, 'outside the corral' could simply be rendered as *la hambeli oka*. Cf. also *la hambeli kotaku*, 'outside the village'.
 14 In ritual language, two ends of a valley or dale (*lolangu*) are similarly called the *katiku lolangu* and *kiri lolangu*. In this case, however, the two terms, so far as I know, do not express a regular orientation, but simply a complementarity of parts. Indeed, it is a common practice in parallel speech to conjoin two phrases that refer to opposite extremities to denote the entirety of an area in question. This is also done, for example, with *katiku woka* and *kiri woka*, when referring to a field. Another usage of this sort is *dia kotaku, luru kotaku*, 'upstream village, downstream village', which denotes a village, and its inhabitants, as a social unity.
 15 In this regard it is worthwhile to note that in six dialect areas of western Sumba, the words for 'up, above' (*dèsa, dèta, bondo*) and 'down, below' (*bawa, wawa, lôla*) are also used for 'upstream' and 'downstream' (see Wielenga 1917:47, 63). The same usage is found in Rotinese (Fox 1968:46). In Kapunduku, moreover, two houses of a clan located upstream and downstream from one another in the former chief village, were distinguished with the phrases *mbara deta*, 'upward direction' and *mbara wawa*, 'downward direction', though in this district the terms for upstream and downstream are *dé* and *loru*. Contrary to what might be supposed, *dia* and *dita*, however, appear to derive from separate Austronesian roots: **udik*, 'upstream', and **a(n)tat*, 'above' (Dempwolff 1938:160, 16).
 16 *Katiku* in the second of these phrases is not essential. The expression is thus often shortened to *katiku tana, mata wai*, 'head of the earth, source of the waters'.
 17 In Kédang, the horizon is similarly called *eléng puén*, 'trunk of the sky' (Barnes 1974:203). *Puén*, which is comparable to eastern Sumbanese *pingi* (see Chapter I), can also mean 'source' or 'origin'.

- 18 As elsewhere in Indonesia, the word for sun (*lodu*) also means 'day'; thus *mata lodu* might also be glossed as 'source of the day'. The combination of words equivalent to *mata* and *lodu* to form a compound name for the sun is a common feature of Austronesian languages (see Barnes 1977a: 305).
- 19 One phrase that denotes the entire world is *panggubulu awangu tana*. *Panggubulu* is 'placed upside down (e.g., of a bowl)' and thus suggests an image of the heavens as an inverted semi-globe encompassing the earth.
- 20 In this regard it is interesting to note Coomaraswamy's remarks concerning the symbolism of sky and earth in Hindu thought, in particular his statement that '... from one point of view the Sky is feminine to the Sun, but from another the Sky is no less male to the earth ...'. (1942:49).
- 21 The association of the Head of the Earth and wife-givers is supported by the appearance in certain traditional narratives of characters, clearly identifiable as or symbolically equivalent to wife-givers, called Rambu Kahi from the Head of the Earth and Uumbu Ndilu from the Head of the Earth. In one context of Rindi ritual speech, moreover, I found the Head of the Earth referred to as 'by the side of the *tuya* and *polangia*' (*la lihi tuya polangia*), terms which both designate the mother's brother and prospective wife's father.
- 22 Tham Seong Chee (1977:32) remarks that the head is regarded as a 'fountain or source' among the Malays (see also Austronesian **ulu*, 'head', 'beginning', Dempwolff 1938:162). Another indication of the conjunction of 'head' and 'source' in Rindi thought is found in the phrase *katiku karimbua*, 'buffalo head', which denotes that part of the trunk (*pingi*) of a large tree located just above the roots. It should be noted, then, that *pingi*, 'source, etc.' is partially synonymous and sometimes conjoined with *mata* in ritual language (see Chapter XIII).
- 23 The pattern whereby opposed spatial extremities are represented in the same way is further instanced in the phrase *na yu na kaladana*, 'the tongue (of the river)' (*yu* and *kalada* are synonymous), and *yu mananga, kâpa mananga*, 'the tongue and palate of the river mouth' (also called *ngaru mananga*, 'estuary mouth'), which refer respectively to the 'head of a river' (*katiku luku*) and its 'estuary base' (*kiri mananga*).
- 24 In rites performed to dispel an incestuous relationship, for example, it is requested that the 'heat', the offence and its consequences, be carried away 'to the tongue of the estuary, the palate of the river mouth; to the angry sharks, and the angry rays; to the long beach, and the broad sea; to the branches of the *lari* tree (a species which grows near estuaries), and the top of the coral stones' (*la yu managa, kâpa mananga; la iu mbeni, la pai mbeni; la wara malai, la tehiku mbâlru; la kajanga ai lari, la pinu watu mbuli*). 'Tongue' and 'palate' of the river mouth refer to the banks either side of the estuary.
- 25 I found no evidence that clearly showed the sea to be conceived as either masculine or feminine in relation to the rivers, though I was once told that the sea could be distinguished from the shoreline (*paliti*) in this way, as could an estuary and a river. The sea and the estuary, in these contexts, were said to be male. In common with other eastern Indonesian societies, the Rindi also distinguish a 'male sea' (*tehiku mini*) from a 'female sea' (*tehiku kawini*). The former term denotes the less navigable waters of the south coast, and the latter the calmer waters of the east and north-east coasts. The dividing line thus seems to be approximately the area about Wai Jilu, i.e., the head of the island. The classification is applied in essentially the same way in central Timor (see Grijzen 1904:2, cited in Le Roux 1929:32-33).

- 26 This clearly suggests an association between the ancestors and the sun. The association of the heavenly bodies with divinity is discussed in Chapter V.
- 27 As I shall elaborate in Chapter VI, the key category in this regard is 'earth', *tana*.
- 28 It should be noted, however, that the Base of the Sky itself, as it lies across the sea, is not referred to as *luru*, 'downstream', but as *papa*, 'on the other side'.

CHAPTER IV

- 1 Dempwolff (1938:158) gives the Austronesian root as **i'umanget*, 'spirit'.
- 2 While the form of the *hamangu* is spoken of as resembling that of the body, these facts suggest, then, that the Rindi do not think of the soul as an 'appurtenance', material or otherwise, of the person, as Lévy-Bruhl (1965: 134) says is always the case among primitives. Nor do they entail that the Rindi idea of the soul is 'permeated with substantial images' (Cassirer 1955-II:77). The *hamangu*, moreover, seems not to be thought of as an impersonal substance which is divisible and reducible, as Kruyt (1906:16; n.d.: 5) claims of Indonesian notions of the soul.
- 3 Entries in Kapita's dictionary (1974) indicate the Wawewa (western Sumbanese) term *mawo* to be the common equivalent of *hamangu*, *mangu*, and *maü*. *Mawo* is further used to denote what in eastern Sumba is called *pahomba*, a term I discuss later in this chapter. It would appear, therefore, that various aspects or manifestations of spirit which are distinguished with different names in the east are covered by a single term in the western part of the island.
- 4 This is expressed in ritual speech as 'in the mountains, on the plain, at the river, in the gullies' (*la tandula, la maràda, la luku, la kanjonga*).
- 5 It is worth noting, then, that some informants suggested that *hamangu* in the sense of 'soul' and *mangu(ngu)*, which appears in expressions such as *mangu umangu*, 'owner, occupant of a house', and *mangu anangu*, 'parent' (*ana* is 'child'), were related. It was explained in this regard that without the soul of the 'possessor' the object would not exist or assume its present form.
- 6 Cf. Indonesian *bersemangat*, 'to be enthusiastic', from *semangat*, 'soul', 'consciousness', 'zest'.
- 7 In some cases the modifying term can be used alone with the same meaning, while in others it acquires this meaning only when conjoined with *eti*, as respectively in the two examples cited above.
- 8 I therefore found nothing to support Wielenga's (1910c:242) claim that the liver is the 'principal seat' of the 'soul substance' (Du. *zielestof*). In any case, as the Sumbanese equivalent of this latter term he gives *ndewa*, 'spirit', and not *hamangu*.
- 9 In Rindi, *ranga* appears in the word for the common cold, *maranga*, which can be glossed as 'something moist'.
- 10 Cf. the Indonesian term for 'countenance', *air muka*, literally 'facial liquid'.
- 11 With phrases such as *papaha ura lima, ura wihinggu*, 'wife of the lines of my hands and feet', a close connexion with the subject, influencing the speaker's fate and fortune, is expressed.
- 12 Onvlee (1973:35) records the expression *ura uma*, which he translates as 'honour, reputation of the house', but I never encountered the word used in this sense in Rindi. There is the expression *ura watu umamu, àkatu kabihumu*, 'the *ura* of the foundation of your house, disaster (to) your clan', which

- implies a curse effective if an obligation is breached. Here, though, *ura* is apparently to be understood as 'misfortune'.
- 13 Although I once encountered the phrase *ndewa meti*, 'ndewa of death', as a reference to the *ndewa* which accompanies the *hamangu* to the land of the dead, when I further enquired after its meaning informants denied that there was any such thing, claiming the expression to be, in effect, self-contradictory. If *ndewa meti* is a standard idiom, however, it might simply be a way of referring to the *hamangu*. Another possibility, as I shall show below, is that *ndewa* here is intended in the sense of 'fate'. Referring to eastern Sumba in general, Nooteboom (1940:43-6), on the other hand, claims that *ndewa* is what goes to the land of the dead, while the *hamangu* remains in the house. The speculations he proffers concerning the possible relationship between these two entities, however, are based on fragmentary and often vague information provided by earlier authors.
 - 14 Onvlee (1973:106) suggests *ndewa* to be a suitable gloss for the Christian notion of God.
 - 15 Of two spouses who die about the same time, it is said that they are 'matched in *ndewa*, of equal *hamangu*' (*pamera ndewa, pahama hamangu*). See also *njara mera ndewa, ahu mera ura*, 'horses matched in *ndewa*, dogs of equal *ura*', which refers to parties who share common circumstances or who in one or another sense are regarded as equals, and *ndewa la tana, ura la awangu*, '*ndewa* in, on the earth, *ura* in the sky', which describes the bereavement of mourners.
 - 16 The use of *rànja* here is comparable to that in the term *ata rànja*, which refers to a life slave (see Chapter X, Section 1). In the form *ndewa rànja, pahomba rànja*, the concept seems to denote the immortal aspect of the soul.
 - 17 See Sanskrit *div*, 'to shine'. This idea would appear to contradict Onvlee's communication (cited in Schulte Nordholt 1971:145) that in Sumbanese the attribute of 'shining' is not associated with *dewa* (i.e., *ndewa*).
 - 18 It is also said of a dead man that 'he is already sitting with his *ndewa rànja*' (see Kapita 1976a:162).
 - 19 *Homba* is possibly a reflex of Austronesian **t'embah*, 'reverence' (Dempwolff 1938:150); see also Indonesian *sembah*, 'homage, obeisance, etc.'. In his dictionary, Kapita (1974) refers the word to Toba Batak *sombaon* (see Tobing 1956:94), a derivative of *somba*, which Dempwolff also lists with **t'embah*.
 - 20 One informant stated that *ndewa* and *pahomba* could be distinguished as feminine and masculine, in the sense that the former is 'what is contained' and the latter 'what contains'. Onvlee (1973:107, 108) suggests that *ndewa* and *pahomba* are related by analogy to a number of other paired terms, such as sun and moon, hot and cool, and so on; but I encountered no evidence in Rindi that would indicate any direct associations in this regard.
 - 21 In the Kambera narrative recorded by Wielenga which I cited just above, the hero meets his *ndewa rànja* beneath a tree, apparently some distance outside his village. Quite possibly, then, it is his *pahomba* shrine that is referred to here.
 - 22 Like many *pahomba* in this part of Sumba, the one belonging to the Rindi nobility is at present neglected and in disrepair. Just before I left the field, though, plans were being made to restore it.
 - 23 I was also told that an offering should be placed at the *pahomba* as part of the annual renewal ceremonies that concern the various altars (see Chapter VI), but this too seems no longer to be done in Rindi.
 - 24 For example, the various altars (*katoda*) which I shall discuss below are

expressly identified as places connected with certain manifestations of *ndewa* (e.g., the *ndewa pangangu*, 'spirit of food, crops', or in another sense, perhaps, 'fortune of the crop') and, at the same time, in each case, as the place of a male and a female spirit. But it was usually denied that these entities were one and the same thing.

CHAPTER V

- 1 There is not enough space to list all the expressions I recorded, but only those that are in some way representative or suggestive. Phrases used to refer to God in eastern Sumba are also found in Kapita (1976a:93-4) and Lambooy (1930:277-79).
- 2 Referring to the use of conjoined masculine and feminine terms to describe God in Manggarai, Verheijen (1951:28) similarly suggests that this practice should be considered in the first place as 'a product of the (literary) language' rather than as an indication of the 'marriage of heaven and earth', i.e., the idea of God as a combination of the male and female halves of the cosmos.
- 3 The phrases *uma makandii*, *uma makanawa*, 'silent and still house', refer to a clan's ancestral house. As I shall later show, however, God is linked with such buildings only in a rather indirect way.
- 4 *Miri*, 'lord, master (mistress)', a term which slaves, especially, use to address the nobility, is also employed as a reference to God.
- 5 According to Kapita (1976b:17), the terms derive respectively from *sang kulah* and *sang aji*, which in western Indonesian languages (apparently Javanese in particular) denote a ruler or monarch. *Sang* is a widely used honorific epithet, while *kulah* means 'crown'; *sang kulah* is thus the title of a Javanese monarch, whereas *sang aji* is that accorded to lesser rulers, such as the sultan of Bima (Kapita *ibid.*). Jonker (1893:93) thus gives Bimanese *sangaji* as 'monarch'. While Kapita claims that *hanggula* designates a former ruler or one who is currently inactive, and *hanganji* an active ruler, in Rindi the latter term, like the former, always refers to a ruler who is inactive. In Manggarai the cognate *sengadji* is used both to refer generally to persons in authority and to address the 'Highest Being' (Verheijen 1951:41), thus in a way similar to that found in Rindi.
- 6 The usage is found, for example, in Manggarai (Verheijen 1951:33), Atoni (Schulte Nordholt 1971:142), Kédang (Barnes 1974:103), and apparently also in western Sumba (see van Dijk 1939a:515).
- 7 The sun and the moon are usually said to be made of gold and silver respectively. One man, however, claimed that while the sun is made entirely of gold, the moon contains both gold and silver. But he later reversed this, claiming instead that the moon is entirely of silver while the sun contains both metals. The stars are mostly silver. The metals are deposited in the earth when the sun and moon set and when a star falls from the sky.
- 8 *Marai romu*, which Kapita (1974) glosses as 'to begin the day', refers equally to Venus — which, as the Rindi recognize, is not always visible as a morning star — and to this time of day. The evening star is called *kanduna hau malingu* (or *kalitu*), 'star towards the evening (or twilight)'. Though I was told that the two appearances of Venus are 'the same', later enquiries suggested that this refers to a similarity of size and brightness rather than to an absolute identity.
- 9 As throughout the southern hemisphere (see Andree 1893:362-6), in eastern Sumba the rising of the Pleiades at sunset and the simultaneous setting of

Antares mark the coming of the rainy season and the time planting should begin. Specifically, I was told that planting should commence when Antares is no longer visible at sunset and should be completed before the tail of the constellation Scorpius (to which Antares belongs) has disappeared from the western horizon. The constellation is thus called *tanda tondungu*, 'planting sign'.

- 10 With regard to the myth, it seems significant that *kawiru*, a dialectal form of *kawuru* (the Pleiades), also means 'isolated, hidden away'. *Tanda ndaungu*, 'year sign', can denote either Antares or this star and the Pleiades together.
- 11 'Not knowing one's brother or sister' (*nda pingu anamini anawinina*) is an idiomatic reference to incest in Rindi. The significance of 'indigo water', i.e., the dye in solution, is its smell, which is said to induce dizziness. Interestingly, the dark blue colour produced by the dye is also called *kawaru*, the name of the Pleiades.
- 12 In addition, the incestuous man is described as 'the one who looks down and watches over the year of the rice and the season of the maize', which seems to refer to the part played by Antares (and the constellation Scorpius) in defining the beginning of the wet season. The woman, on the other hand, is the one more directly associated with the act of incest and its consequences. On balance, then, male and female seem to be associated here with the positive and negative aspects of divinity respectively.
- 13 In another version of the myth there are two children, a boy and a girl, and both are placed at the Head of the Earth. The idea that food crops originated from parts of a human body, a theme which occurs in other Rindi myths, is common in Indonesia.
- 14 Referring to similar ideas in Kédang, Barnes (1974:110) remarks that '... the separation of the earth and sky was necessary for the coming into being of the world, and the original state is comparable to incest'. In Kédang, *ula-lojo*, 'moon-sun', the name for God, is also a coarse term for incest (ibid.:109).
- 15 Lambooy compares *ra* (see Austronesian **raya*, 'to be big', Dempwolff 1938:58) with *da*, which in eastern Sumbanese as in other Austronesian languages (see **Da*, Blust 1979:244n), is the third person plural pronoun (nominative and possessive) and the plural definite article. As *dangu* it means 'many'.
- 16 Lambooy (1937:425-26) also provides a critical outline of the etymology of *marapu* offered by earlier authors. While *apu* at present means 'grandmother, female ancestor', Lambooy suggests it might also have a masculine form (see further Chapter XIV).
- 17 See Brandstetter (1916:103), who gives Austronesian **ra* as an 'honorific particle' (cited in Blust 1979:244n).
- 18 To cite just one example, altars in western Sumba are called *marapu*, whereas in the east they are named *katoda* (see Chapter VI).
- 19 The longer title of the *marapu* of the clan Ana Mburungu, who is usually called just Umbu Lutungu, for example, is (Umbu) Lutungu — Eti Ndamungu, lai Pala — lai Lapu. The latter personage, also called Umbu Pala — Umbu Lapu, is usually, though not invariably, represented as a single individual. This recalls the practice of rendering the name of an individual dyadically which Fox (1968:27) reports for Roti.
- 20 In this case the *marapu* is described as 'the one who spreads his wings and raises his arms' (*na mamhowangu ru kàpana, na mapahakangu halilina*), which refers to a hen who leaves her young to the mercy of predators. The expression is also noted by Kapita (1976a:169).

- 21 *Mulungu* is possibly related to Austronesian **mula*, 'beginning, origin' (Dempwolff 1938:107). See Indonesian *mula*, 'beginning, cause, etc.', and eastern Sumbanese *pamula*, 'to plant, sow'. It should also be noted in this regard that in the Mangili district rain is called the sky's semen (Onvlee 1949:455).
- 22 Though there are very few Christians and hardly any Muslims among the Rindi, like the eastern Sumbanese generally they seem to have readily incorporated Christian and Islamic ideas into their mythology. Wielenga (1910e:332) refers to a myth told to him in Mahu in the early part of this century which relates how the first woman was created from the rib of the first man. Interestingly, the couple in question were called *ina* and *ama pakawurungu* (see Section 1 above).
- 23 Since the interpretations were mostly offered by educated informants, however, I am not sure how far traditional Rindi consciously identify these names with places known phenomenally to exist at present. An elderly informant once explained that while the places that form the route of the *marapu* still exist, they are no longer visible.
- 24 Though Ndima is the common Sumbanese name for Bima (on Sumbawa), Maka and Ndima were also interpreted as Mecca and Medina.
- 25 In Rindi I was told that the bridge linked Sumba with Bima (Sumbawa). Dammerman (1926:27), too, reports that it was Bima, while Kapita (1976a: 12-13), on the other hand, says it was Flores.
- 26 The complete form is *maheda, mameti*. The word *heda*, which is synonymous with *meti*, 'dead, to die, death', appears only in ceremonial language.
- 27 Crop failure, lack of rain, cattle disease, and pestilence are especially attributed to the dead. It seems significant, then, that Rindi thought connects all these things in one or another way with the earth.
- 28 Lambooy (1930:282; 1937:427) also notes the existence in eastern Sumba of graves reputed to belong to *marapu*.
- 29 Earlier authors (see Wielenga 1931:17; Lambooy 1930:282; 1937:433) record the eastern Sumbanese expression *marapu maluri*, 'living *marapu*'; but I never heard this used spontaneously in Rindi, and on the whole it seemed not to be readily understood there. Some people I questioned, however, supposed the phrase referred simply to the first ancestors, while one informant equated it with 'the creator of men' (*mawulu tau*), which as noted usually refers to God.
- 30 Of someone who has died it is thus said that 'he has gone to become (a) *marapu*' (*luananyaka pamarapu*; see also Kapita 1976a:162; Lambooy 1937: 430), and that 'he has gone (or returned) to the one who makes and plaits men' (*luananyaka* [or *belinanyaka*] *la mawulu tau la majii tau*).
- 31 Evidence recorded by Wielenga (1910e:330) and Kapita (1976a:15) suggests that this method of distinguishing human ancestors from divine namesakes may be general in eastern Sumba.
- 32 In some parts of eastern Sumba, the relics are called *topu marapu*, '*marapu* mat' (Lambooy 1937:430), thus suggesting that the *marapu* is thought to sit upon these.
- 33 Since the latter, unlike the former, can be exposed to the light of day, they are also distinguished as *tunggu lodu* and *tunggu rudungu*, 'day and night possessions'.
- 34 This entity, the *matimbilu halela*, is thus further described as 'the one who rises back and forth, who descends to and fro, the one with the agile form, the diligent liver (heart)' (*na mahei luangga mai, mapuru luangga mai, mahalela hada, mamaràna eti*).

- 35 'Notch' and 'groove' refer to the indentations at the tops of the house posts into which the cross beams fit. My translation of *kalarangu* as 'flutes' is tentative, and assumes the word is related to *lara*, which denotes the flutes cut around the tops of the main posts.
- 36 See, e.g., *uma mbotu hei*, *mbotu puru*, 'house of heavy ascending and descending', as a reference to an ancestral house (*uma marapu*).
- 37 Rindi with knowledge of the Bible identify this personage with Noah.
- 38 This contradicts Wielenga's statement (appended to Kruyt 1922:477) that the *marapu wai maringu* is not an ancestor but a powerful 'spirit' or 'demi-god'. Since all *marapu* might be described as 'demi-gods', however, the statement is in any case equivocal.
- 39 This rather curious designation seems to express the ambiguity of this figure, for while he effects a cooling, he is himself regarded as hot. *Maringu mbana* can also mean 'surpassingly, excessively cool'; but this does not appear to be the sense intended here.
- 40 In ritual speech he is said to 'pour out the fragrant and cool water' (*buringu wai mangolungu*, *wai maringu*) and 'still the mouth of the horse, cool the liver of man' (*pamànjaku ngaru njara*, *pamaringu eti tau*).
- 41 When the functionary of the *wai maringu mánjaku* has accumulated a sufficient number of metal flakes, he consecrates them and places them with the relics of his clan. Sometimes, though, the principal requires this to be done immediately, in which case he will present the metal wrapped in cotton pellets.
- 42 Two clans in Rindi regard the animal as *marapu*: Pakilungu, a female ancestor of which married a crocodile, and Kihi, whose ancestor was rescued by a crocodile after his mother's brother placed him in a large jar (*kihi*) and cast him into the sea. The now extinct clan Rindi is also said to have had a special relationship with the beast. Among animals, crocodiles are generally revered by the eastern Sumbanese. They are thought to inhabit a large village beneath the sea, where they assume human form. Formerly, it is said, crocodiles were friendly and co-operative towards humans, transporting them across rivers on their backs. According to myth, it was the treachery of a man called Kapilandu, 'deceiver', which led to the breach of this amicable relation. It is thus permitted to kill a crocodile only when the animal has attacked humans or livestock. In accordance with the idea that the attack is a punishment for transgression, moreover, the Rindi say that a crocodile will never seize an innocent person and that if it should inadvertently do so, it will release him unharmed.
- 43 The clan myth which tells how this came about is nearly identical to a story from Anakalangu in western Sumba recorded by Onvlee (1973:191-2) and very similar to a popular narrative widely known in Rindi. A variant is also found on Savu (van de Wetering 1926:574-5). By contrast to the Kurungu myth, however, these other versions are apparently unconnected with any clan tradition.
- 44 An attack by a crocodile is similarly known as *murū wuya*, 'power of the crocodile', and a lightning strike as *murū kabàla*, 'power of the thunderbolt'. According to Kapita's dictionary (1974), the latter term can also refer to a disease. The notion of *murū* is further discussed in the next chapter.
- 45 Most of the expressions Lambooy (*ibid.*) notes, e.g., *marapu manu*, *marapu njara*, *marapu nimbu*, and *marapu kandunu* (chicken, horse, spear, and star *marapu*), I never encountered in Rindi. They do speak of, for example, a 'wind *marapu*' (*marapu ngilu*), a phrase which Lambooy also lists; but this, too, they identify with a particular (human) ancestor. Since in western Sumba

marapu does indeed appear in contexts unconnected with clan forbears (see van Dijk 1939a), however, this may of course be the case in more westerly parts of the eastern region as well. There is here, then, an interesting comparative question.

CHAPTER VI

- 1 The earth is also addressed as *tana ratu maràmba*, 'earth, land of (or that is?) the religious leader and noble ruler'. As I shall later show, this suggests a totality in respect of both spiritual and temporal concerns.
- 2 Wielenga (1910d:309) mentions the term *marapu tana*, which he defines as the spiritual owners of uninhabited land populated by subordinate spirits called *patau tana*. Clearly, these are what the Rindi call *maràmba tana*. The term *marapu tana* is neither used nor understood in Rindi.
- 3 Cf. the Atoni *pah tuaf*, described by Schulte Nordholt (1971:146, 148) as the 'lords of a particular territory' and 'lords of the earth', which also take the form of snakes. I was told in Rindi that should a snake enter a house, the building must be ritually cooled. This accords, then, with the identification of snakes with spirits of the outside, which are categorically hot. Such an occurrence, which is considered inauspicious, thus evidently represents a confusion of inside and outside that must be resolved ritually.
- 4 The species include the *wàngga* (*Ficus benjamina*), *wunggut* (*Ficus glabella*, Bl.), *karuku* (*Ficus sp.*), and *wudi* (*Ficus religiosa*). All except the *wudi* are species of banyan. Following Bosch (1960:67), the *wudi*, or strangling fig, is the *bodhi* tree of Gautama Buddha, which like the closely associated banyan, is one of the sacred trees most frequently mentioned in the Indian religious literature. He also notes that both trees, being among the largest growing in the subcontinent, are called 'lords of the forest'. Though, by contrast to the species of banyan, *Ficus religiosa* lacks aerial roots, the two sorts are often confused in Indian art and literature (Bosch 1960:70). Wielenga (1910d:307) mentions a custom of placing an offering at such a tree when entering the territory of the spirit thought to reside there. When this is done, he says, the purpose of one's journey must be stated and assistance may be requested from the spirit. I did not hear of this practice in Rindi.
- 5 The name *patuna* is said to mean 'place of the eel (*tuna*)'. 'Eel' was explained as a euphemism for 'snake', and with reference to the idea that the inhabitants of this place are oily and shiny, and secretive, like eels. As snakes can be said to resemble eels in these respects, the two interpretations seem to be complementary. The idea that earth spirits are shiny provides another instance of the association of this quality with supranormal or divine power.
- 6 *Wàndi* (possibly related to the Malay *badi*; see Endicott 1970:66 et. seqq.) is the distinctive quality of people who are witches. *Ndewa tana*, 'spirit of the earth', is a rather vague expression, and informants disagreed as to what in particular it should refer. While sometimes it was said to denote malevolent spirits such as the *maru tana*, other uses of the term suggest the spiritual aspect of the earth *per se*, including its positive as well as its negative qualities.
- 7 In ritual speech the *maru tana* are thus designated as 'the ones who massage themselves with filth, who bathe themselves with blood' (*makokuru wàngu taina, maihu wàngu riana*).
- 8 As I observed, in other parts of eastern Sumba a similar rite is performed about May.

- 9 Indonesian speakers in Rindi refer to these creatures as *orang hutan*, 'man of the woods, orangutan'. A nobleman who had visited the Surabaya zoo told me he had seen a *makatoba* there. This he later identified as an orangutan. There are no apes of any sort on Sumba, however.
- 10 Elsewhere in eastern Sumba these giants are called *meu rumba*, 'wild cat'. Interestingly, a supposed characteristic of the Sumbanese wild cat is that it is cannibalistic.
- 11 One characteristic often mentioned in these tales is their voracious appetites; they eat not only food but eating and cooking vessels and utensils as well.
- 12 Interestingly, Kapita (1974) gives *kàmi*, the old woman's name, as 'village messenger' (Indonesian *kebayan*). She thus seems to be a sort of messenger of the fates.
- 13 The ancestor of one eastern Sumbanese clan, Menggitu, is said to have been such a giant.
- 14 Though I cannot recall ever having encountered it in Rindi, Kapita (1974) lists the phrase *patau tehiku*, 'inhabitants of the sea', which evidently refers to the spirits that normally appear as sea creatures and thus corresponds to *patau tana* as a reference to earth spirits. On the other hand, I did hear the phrase *maràmbu tehiku*, 'lords of the sea', which denotes a manifestation of spirit that similarly parallels the 'lords of the earth' (*maràmba tana*).
- 15 The possession of a *wàndi* is what distinguishes a real witch from persons the Rindi sometimes also call witches. They thus distinguish a figurative sense of *mamarungu* as a reference to thieves and trouble makers. It is apparently this use of the word that Kapita (1974) has in mind when he glosses it as 'a person who is always causing trouble for others'.
- 16 When a witch thus disappears, his clothes, which remain in place, are said to retain the appearance of having a body inside them. If such a thing is encountered, then one should bind the clothes at both ends, so that when the *wàndi* animal returns the witch must materialize outside his clothes and thus reveal his identity. If the bite of a creature of the sorts identified as the *wàndi* of witches results in long suffering or death, it may then be suspected that it has been deliberately sent by its owner.
- 17 Schulte Nordholt (1971:150) notes a similar idea among the Atoni of Timor, as does Barnes (1974:212) for Kédang.
- 18 Among the Kodi of western Sumba, who have a system of double descent, witchcraft powers are matrilineally inherited and restricted to the members of two of the matrilineal descent groups (*wala*) of the lowest social standing (van Wouden 1956:225). In Rindi however, witchcraft can be inherited through both males and females, and, in contrast to what van Wouden claims for Kodi, it can also be acquired through contagion.
- 19 Though I made no note of it at the time, I seem to recall that witchcraft was not uncommonly attributed to adulterous women and wantons, which would thus suggest an association with uncontrolled libidinous energy.
- 20 As noted, it is also said that when a person enters the spirit world (*patuna*) he must divest himself of his clothes. In this context, however, nakedness seems to signify not so much a simple removal from the civilized state as a transition from one realm to another, as in rites of passage. Thus the person is given new clothes by the spirits.
- 21 One of the Kodi words for witch, *to homoro* (van Wouden 1956:225), appears to be related to western Sumbanese *moro*, an equivalent of *murū*; *to* is 'person'.
- 22 One indication of the connexion between spirituality in general (and not just malevolent spirit) and the night is the previously mentioned designation of

- the clan relics kept in the peak of the house as 'night portion' (*tunggu rudungu*).
- 23 In ritual speech, witches are spoken of as 'those who use night as day and day as night' (*malodunya na rudungu, marudunya na lodu*).
 - 24 The phrase *kalai eti*, 'left-livered', which is synonymous with *kudu eti*, 'small-livered', means 'disappointed, disgruntled'. As on Roti (Fox 1973:356), monkeys are thought to be left-handed in Rindi; hence left-handed persons are described as 'left like a monkey' (*hama kalai buti*).
 - 25 According to native etymology, the term *lamaru*, which denotes the earliest twilight, just after the sun has disappeared from view, is related to *maru(ngu)*, 'witch'.
 - 26 This was held in order to provide protection to a noblewoman whose soul was considered susceptible to attack on account of her having suffered a head injury from a fall.
 - 27 Another resemblance is found in the idea that a man whose wife or lover is a witch will enjoy her protection and thus never suffer accident or injury, so long as he does not reveal to anyone her true nature. (I never heard this expressed with reference to a woman whose husband is a witch.)
 - 28 This is a conflation of the place names Bali, Bima, and Makassar. The referent of *Ruhuku* is unknown.
 - 29 *Kawindu* is the yard or forecourt in front of the house; *ru kawindu* (*ru*, 'leaf, hair, etc') refers to the eaves. In parallel speech this place and the altar located there are called *kawindu, talora; talora* also denoting the entire village square. In some parts of eastern Sumba the village altar is called *katoda paraingu* (*paraingu*, 'village') and is more centrally located in the village. Each house, or at any rate each *marapu* house, is then provided with its own yard altar (*katoda kawindu*). There were three villages in Rindi which had more than one such altar, but this is exceptional, and seems to be due to a village having been enlarged, with later groups erecting a yard altar of their own.
 - 30 The idea thus seems to be that the stake is something to which another thing is tied. The complete expression, used in parallel speech to refer to the entire altar, is *hondu mandungu, pinu watu mbelaru*. Another version is *kanditiku atu, pinu watu mbelaru*, 'stake of heartwood, surface of broad stone'.
 - 31 This particular rite is also known as *pamangu kawuu tana*, 'to feast, give food to the *kawuu tana*'.
 - 32 The opposition of hot and cool is further suggested by the division of the offering placed outside the village into a raw and cooked portion; but I am not certain what it might signify in this case. The only explanation I was able to obtain was that the cooked food is intended for the *kawuu tana* while the raw portion is for indigenous earth spirits (*maru tana*) and witches who accompany them. Another possibility is that the cooked food is for the spirits of the gate altars. It is not placed on these altars, however.
 - 33 Before the altar stone is set in place, I was told, this spirit is present everywhere, but once this is done it becomes concentrated in the altar.
 - 34 It seems significant, then, that the expression *ina bungguru, ama bungguru* is practically synonymous with *ina ukurungu, ama ukurungu* and *ina pakawurungu, ama pakawurungu*, which as noted refer more directly to God.
 - 35 *Kandoka jala*, which is the phrase invariably conjoined with *watu uma*, 'house stone', when referring to the foundation of a house, denotes a stump or post on which fish nets (*jala*) are hung. In Rindi, however, there is nothing in particular located beneath or near the house to which this might refer, and I was unable to clarify its exact significance in this context.

- 36 The phrases *tandula ndema awangu, tara tuka tana*, 'peak that holds up the sky, spur (?) which supports the earth', were mentioned in this connexion. The post may be made of earth, and it was also once said to float on water. As noted, the phrase *padua tana* can also refer to the (horizontal) centre of the island of Sumba.
- 37 Similar ideas are found in Mamboru (Kruyt 1922:602), where the earth is said to hang from a 'cord (umbilical cord)' on which the mouse then gnaws, and in Kédang (Barnes 1974:105), where the cry 'we are here' is addressed to a man who is thought to hold up the earth. Interestingly, the Rindi claim that earth tremors are most common during the 'revered months' (*wula tua*), the transitional period between the two major (wet and dry) halves of the year.
- 38 In parallel speech, these places, and their associated spirits, are called respectively 'the gutter and the eaves' (*kilimbonga, ru kawindu*) and *tundu lindi, peri wihi, wutu lindi, panggari bangga*, which, though difficult to translate exactly, might roughly be glossed as 'the raised step, where the foot rubs against, base of the bridge, lower part of the verandah'. 'Bridge' (*lindi*) apparently refers to a beam sometimes placed on the ground between the gutter and the verandah to serve as a step.
- 39 *Amahu* is cognate with Indonesian *emas*, 'gold'. In Rindi the word is used, with qualification, to refer to gold, silver, and copper or brass (*amahu wudu*) but not other metals, such as iron (*bahi*), brass or bronze (*kaliyangu, naii*), or tin and zinc (*tambaka*). *Amahu* is also a general term for money.
- 40 Kruyt (1922:568) mentions the placing of gold only beneath the principal post (*kambaniru uratungu*) in other parts of Sumba.
- 41 I refer here especially to gold and silver. There is some evidence that iron is thought to scare witches and malevolent spirits in eastern Sumba (see Onvlee 1973:72), but the Rindi never employ iron in ritual in the ways described above.
- 42 Barnes (1974:71) reaches essentially the same conclusion with regard to the Kédang practice of placing candlenut shells in post holes, in order to keep termites from eating the posts. His view that this is a means of propitiating rather than driving off the termites thus contrasts with that of Endicott (1970:133) who, with reference to the similar use of candlenut and iron among the Malays, interprets the custom as a way of sealing the boundaries between the earth and the house.
- 43 It is interesting in this regard that *wudu*, the word for copper and brass, also means 'joint', though in the latter sense the term more usually appears as *kawudu* (*ka* is a common fused prefix). Since a good deal of the precious metals the eastern Sumbanese now possess have been acquired relatively recently, it seems probable, then, that copper and brass were once more widely used in ritual than at present.
- 44 To indicate briefly a wider context for this discussion, it is useful to note Barnes's (1974:61, 73) interpretation of gold in Kédang as something that is capable of crossing boundaries and, in one context, that connects the house with the ground. But while this agrees with the use of metals as media of divinity in Rindi, as I have shown in the case of the metal relics consecrated to the clan ancestor, they are also represented as things that disjoin.
- 45 By contrast to the individual altars at the head of each field, a rite is held at the *bungguru* altar only once annually, as part of the annual renewal ceremonies. I was told that if the yield is poor and resources do not reach, this can be dispensed with altogether, thus confining the rites to the individual field altars.
- 46 This was said, for example, of the altar at the 'mouth' of the main irrigation

channel of a complex of the rice fields (*katoda ngaru wai*). Interestingly, as regards its disposition and function, this place is reminiscent of the Head of the Earth, which as noted also has feminine associations.

- 47 Cf. the distinction between the 'distantly regulatory' and 'immediate, life-giving' aspects of divinity, which Barnes (1974:123) maintains is the primary contrast in Kédang theology.
- 48 This is also consistent with the tendency to associate this realm with marginal and relatively disadvantaged persons in general and, in oral literature, especially with orphans.
- 49 One expression used to refer to the dead is 'those who occupy the house and house floor' (*da mandapu uma, kaheli*).
- 50 See, e.g., the Ema phrase *rae ubun*, 'masters of the earth', which refers both to the dead and to a class of malevolent spirits (Clamagirand 1975:146, 121), and the widespread Indonesian term *nitu*, which is similarly applied both to earth spirits and to the dead among the Atoni (Schulte Nordholt 1971:146).
- 51 A connexion is further suggested by the fact that spirits associated with the shrines, like external earth spirits, can assume an embodied form, viz., that of a tiny bat; and the evident antithesis between both the *patuna* and the *pahomba* on the one hand and the dead on the other.

CHAPTER VII

- 1 At the annual renewal ceremony (*pamangu*) at the *bungguru* altar (see Chapter VI), a metal flake is especially offered to request that no harm befall the crop as a result of menstruating women having entered the fields. I also heard that tobacco gardens are particularly out of bounds for menstruating women.
- 2 According to Onvlee (1949:455), the Mangili word for 'semen' is *wai palinju*. The related Rindi word, *wai palunju*, however, though it may be similarly used (*palunju* is a variant of *paluhu*, 'evacuated'; *wai* is 'liquid'), usually means 'urine'. Another, euphemistic, reference to semen — or, more generally, to the genitor's contribution to conception — is *wai hanggobungu*, literally 'sweat'.
- 3 Cfr. *paanangu*, 'to have (i.e., possess), have born children', from *ana*, 'child (in the relative sense), offspring'.
- 4 I was once told that if a man's wife lies to his right a male child will be conceived, and if to his left a female. The latter arrangement, however, was also said to result in a left-handed, mute, blind, cross-eyed, or otherwise deformed child. This provides, then, another indication of the inauspicious nature of the left side.
- 5 In certain major ceremonies, the special offering of betel and areca for the clan ancestor, on these occasions called *pahàpa paberi pabata*, 'chewing ingredients divided and arranged (in rows)', consists of a male and a female portion, placed in separate trays. Among some clans the tradition is to provide the male portion, which is placed to the priest's right, with eleven pieces of areca nut, and the female portion, to his left, with ten pieces. Among others, though, the male and female portions contain eleven and nine pieces respectively. (The Rindi themselves recognize these variations in practice between different groups.) As in all rites, each portion includes two betel peppers.
- 6 Onvlee (1973:70-73) has published an extensive list of such prohibitions, many of which I encountered in Rindi.

- 7 The prohibition on weaving, which applies until the child can sit up properly, though, was also referred to the deleterious effect on the mother and child of the backstrap attached to the loom. It seems relevant to this that it is the small of the child's back (*puhu bānggi*) which must become 'firm' (*mandungu*) before he can sit upright.
- 8 That these prohibitions apply until weaning derives from the idea that the negative effects on the food are transmitted to the child by way of the mother's milk. The husband, therefore, is not subject to any dietary restrictions.
- 9 Formerly, when warriors returned from a successful expedition, a man who claimed to have killed would, while dancing, stamp on an egg. If it splattered over the top of his foot his claim was confirmed. In this case, I was told, the egg represented the soul of his victim.
- 10 As elsewhere in Indonesia, opposite sex twins in Rindi are inauspicious, since they are considered to have committed incest inside the womb. In various ways, therefore, they must be kept separate after birth.
- 11 A rule mentioned by Onvlee (1973:72), which seems to express the same idea, but which I did not hear in Rindi, is that a pregnant woman should not enter a rice field when the ears begin to swell — a stage of growth called *pakindi*, 'like a spindle' — otherwise the crop would be harmed.
- 12 The phrase *njala hangatu*, 'incorrectly sliced', is thus applied to a person with more or less than ten fingers or toes. It is for this reason that expectant parents should avoid slicing or shredding materials during pregnancy.
- 13 It was with reference to this notion that the phrase *mawulu tanga mata, lindi uru*, 'he who makes the brow ridge and the nose bridge', which denotes the clan ancestor (*marapu*), was once explained. It should be recalled that the ancestor is also represented as forming a connexion or bridge between mankind and God.
- 14 *Pamandungu pelungu* was once translated for me as 'to make firm the uterus' (Indonesian, *meneguhkan kandungan*). *Pelungu*, though, is not otherwise used to refer to the womb.
- 15 Before the main part of the ceremony, which takes place in the right front corner of the house, the spiritual presence at the yard altar is summoned, with an offering of betel and areca, to ascend to the house floor. It is this entity 'which raises up to the house the means of reproduction and prolificity' (see Chapter VI, Section 3).
- 16 *Habola* also means 'clear, bright (e.g., of the sky)' and 'recovered (of an illness)'. The complementary term is *kapàwaku*, '(to become) clear, opened'. As is shown in a couple of places above, pregnancy is represented as similar to illness in certain respects. It is not, however, classified as an illness (*hidu*).
- 17 An alternative complement of the first of these phrases is 'set right the muzzle of your horse' (*patànjiya na ngora njaramu*). This version thus conjoins travel by land and by sea. It also shows how Rindi ritual language can express a single idea with more than one distinct metaphor.
- 18 Massage is a very common form of therapy and is used for a variety of ailments.
- 19 Contrary to Onvlee (1973:75), it does not appear to be the case in Rindi that the husband is called in only as a last resort.
- 20 Endicott (1970:51) says in this regard that among the Malays metal, specifically iron, is thought to be antipathetic to the child's soul, but I never encountered this particular idea in Rindi.
- 21 I was told that in the Kanatangu district, the umbilical cord and placenta are

- buried at the drainage channel behind the house, on the right or the left side according to whether the child is male or female.
- 22 If a pregnant woman requests salt at night, her amniotic fluid will 'dry up' (*mihi*, apparently cognate with *mehi*, 'salt'). Requesting lime or filling up a lime container at night, on the other hand, causes night blindness in the child. In fact, there is a general prohibition on requesting salt or lime after dark. If one must do so, the euphemisms 'salty pepper' (*mbaku haü mbàru*) and 'white chicken' (*manu bara*) respectively must be employed. It is also not done to take eggs from a nesting box at night. If colour is significant in this context, then the relevant antithesis is perhaps the blackness of the night.
 - 23 *Mihi*, also the general word for 'tide', literally means 'to dry up', and so actually refers to the ebb. In explanation of the association of females with the various senses of this term, it was pointed out that at the ebb tide, sea-shells, which are thought to resemble the female genitalia, are left on the beach. The names of various sorts of shells (*kapai*, *kima*, *kaku*, and *kaminju*) are in fact used to denote a woman's genitals.
 - 24 *Tamu* may thus be used to address a person in ego's genealogical level who bears the same name. It is also more generally employed in the sense of 'name', though not nearly to the extent of English 'name'.
 - 25 For a boy, the order of names should be FF, FFB, FFF, FFFB, etc., and then MF, MFB, MFF, MFFB, etc., and for a girl FM, FMZ, FMM, FMMZ, MM, MMZ, MMM, MMMZ, etc.
 - 26 *Dika* appears to be the root of *kadika* (*ka* is commonly a fused prefix), the bamboo instrument used to cut the umbilical cord. Physically separating the child from the womb might thus be seen as an act of 'bringing into being' (*dika*). This, of course, is done immediately before the name is determined.
 - 27 In parallel speech the ancestor is called *na madekangu tamu*, *na manyura ngara*, 'the one who determines the name, who pronounces (utters, foretells) the appellation'.
 - 28 Wielenga claims in several places that it is the ancestor (or ancestors, according to one account) who, by way of conferring a name, might predestinate the child to an inauspicious death or, as he once puts it, might 'curse' it (1912:209-10; 1913:215; 1923:308). In Rindi, however, it is not an ancestor but a malevolent spirit of the outside who is thought to do so.
 - 29 In one version of the text I recorded, reference is made to 'the one who comes from Java and Ende, from Bima and Makassar'. This is usually understood to refer to the child, who thus follows the route of the *marapu* ancestor, though according to one exegesis, the phrases indicate not so much the child as the namesake ancestor, who also comes from the Base of the Sky. To my mind, this simply underlines the extent to which the two are identified.
 - 30 *Paita*, 'bitter', is one of several words regularly conjoined with *mbana*, 'hot', in ritual language, in which context the two terms convey the same sense, i.e., that of 'dangerous, threatening'.
 - 31 Warming after parturition is a very common custom in Indonesia (see Kruyt 1906:513).
 - 32 Barnes (1974:169-70) records similar ideas in Kédang, where sweat is called *ahaq*, 'light'. In Rindi, therefore, this is another of several particulars which show pregnancy and its aftermath to resemble illness.
 - 33 This and various other words that refer to fatness or fatiness (also greasiness, oiliness) always connote health and prosperity in Rindi. The fat is the most relished part of cooked meat.
 - 34 The offering consists of two broad leaves on each of which is placed four metal chips, a betel fruit, and two slices of areca nut. It is dedicated to 'the

- lord and lady of the river bank and the water's edge' (*Umbu Rambu la hingi luku, la ngamba wai*). The rite clearly expresses the dual theme of obtaining 'what is cool', here identified with the river water, and expelling 'what is hot', or impurity. As I mentioned in Chapter III, the two qualities are linked with the upstream and downstream directions respectively.
- 35 *Mbota*, 'to snap (e.g., of thread)' is used in the wider sense of 'to break a connexion'. I should mention, though, that the request for continued births is by no means exclusive to this particular rite.
- 36 Not all clans in Rindi keep the navel cord, however. Thus people of the clan Kanatangu (Ana Maeri) told me it can simply be allowed to drop off. It seems significant, then, that this is one of the clans that does not divine the child's name by the cessation of bleeding from the navel.
- 37 A parallel instance of this theme concerns the empty rice grains or chaff (*kalamba*) separated in winnowing, which are ritually removed from the garden village after the harvest. These are similarly described in ritual speech as hot and itching.
- 38 That *hàngguru* took place specifically in conjunction with the child's first haircut is suggested by the longer name of the rite, *hàngguru matua, kikiru matua*, 'reception at maturity, shearing at maturity'. When used alone, however, *kikiru matua* usually denotes not the first haircut but the ritual shearing of an adult's hair, which I shall describe in the next chapter.
- 39 I was told an exchange of prestations between wife-givers and wife-takers might take place at this time (see Onvlee 1973:80), but in the cases I observed this did not occur. Formerly, when the rite followed not long after the birth, it was the earliest occasion on which affinally related groups could indicate, by way of an exchange of valuables, their intention to continue an alliance with regard to the future marriage of the child.

CHAPTER VIII

- 1 The root is *tua*. See Indonesian *tua*, 'old' (also 'dark of colour'; 'pure'; 'head, chief'), and *tuah*, which Echols and Shadily (1963) list as 'respect, honour, prestige'. As noted *wula tua*, 'revered month, moon', refers to the annual period of prohibition between the wet and dry seasons.
- 2 The entry in Kapita's dictionary (1974) indicates *kaweda* (old, elderly) to be related to *weda*, which has the further meaning of 'wise, experienced'. It should be noted, however, that *kaweda* is also used in contexts where these connotations do not clearly apply, e.g., to refer to old animals and trees.
- 3 The term actually means 'sweetheart, fiancée': *ana* is 'child, person'; *karia* is 'companion'.
- 4 In ritual speech, however, like *matua*, the phrases are sometimes used in a completely relative sense.
- 5 As *tera* is '(head)-cloth', the expression suggests a woman's loosely wound hair to be the equivalent of a man's head-cloth. In contrast to men, women normally do not wear a cloth on the head.
- 6 When engaged in strenuous activity, women sometimes wind their hair into a higher, tighter bun so it will unravel less easily, but this is not the usual or formal fashion.
- 7 *Makia* can also be translated as 'embarrassment', 'shyness', 'modesty', and 'humility'.
- 8 It is not uncommon, for example, to hear small children using foul language,

particularly of sexual nature. Although adults sometimes grumbled over this (perhaps especially in our presence), I never saw a child being seriously reprimanded or punished for it. Indeed, it was not infrequently found rather amusing.

- 9 With regard to the significance of the forelock, it is worth mentioning the phrases *mapakitangu ru taka*, *mapatokangu kaba mata*, 'one who seizes the forelock and beats on the forehead', which denote someone who has committed incest. *Ru taka* is synonymous with *lunggi taka*.
- 10 Cfr. van Gennep (1960:73): 'I do not see any relation between circumcision and procreation'.
- 11 The word is *kapàndi*, 'to hide away, take shelter'. The novitiates are thus called *makapàndi*, 'the ones hidden away'.
- 12 This is also called *kahidi kàri*. *Kahidi* is knife. *Hotu* refers to incising the ears and noses of horses and buffalo, and to the distinctive marks themselves, which serve as a sign of ownership.
- 13 This is called *mangapangu*. The privilege is accorded to other parties who can be said to be in a marginal, transitional state: e.g., the costumed functionaries (*paratu*) who guard the *marapu* relics of the noble clan during the renovation of its ancestral house and *ndewa* house, and the attendants of a noble corpse during the mortuary rites.
- 14 Although my informants were not impressed by the interpretation, it might just be relevant to this exemption that the word for buffalo is *karimbua* (or *karumbua*): *kari* is not dissimilar to *kàri*, 'to incise', while *mbua* is 'swollen, to swell'.
- 15 Since many of the youths were of the slave class, this constitutes a marked inversion and further expresses the special position the initiates occupy during their seclusion.
- 16 I was also told that female relatives should be referred to with the terms used for their male equivalents, e.g., 'mother' should be called 'father', and so on.
- 17 The Olo Ngaju of Borneo also associate these qualities with the banana (see Kruyt 1906:143).
- 18 After the ceremony is ended the knife is retained by the priest.
- 19 Interestingly, I was once told that it is beneficial to chew sugar cane while undergoing initiation.
- 20 Among the Tetum of eastern Timor, the speech addressed to a newly married couple includes a request that their bodies remain healthy 'like a wholesome banana, like a stick of sugar cane' (Hicks 1976:96). These associations of the two plants thus seem to be widespread in Indonesia.
- 21 Persons below middle age with filed teeth are at present uncommon in Rindi while people over 50, say, nearly always have their teeth filed. The only reason mentioned for abandoning the practice was the severe pain it involved.
- 22 Wielenga (1910b:132) says the stumps are buried with the file beneath a banana tree, but all I heard in Rindi in this regard was that they were formerly buried at the right front corner of the house in the drainage channel. Separate holes were dug for males and females. I never heard that the file was buried as well.
- 23 It is perhaps also relevant in this regard that some people claimed that the threads tied around an infant's wrists and ankles, one purpose of which is to articulate the joints, should be black. As noted, the threads are called 'boundaries of the milk'; so the significant opposition in this case would appear to be the whiteness of milk. In addition, there is the idea that a fowl offered to the deity of the cool water (*wai maringu mánjaku*), who forms a boundary between mankind and threatening forces, should preferably be black. This is

- by no means insisted upon, however; and some people had never heard of the idea.
- 24 Kruyt (1923:385) reports virtually the same idea from Timor.
 - 25 Further information and speculations regarding the significance of tattooing on Sumba are provided by Lambooy (1926:137-39).
 - 26 Extensive data on betel chewing in eastern Sumba have been published by Onvlee (1973:27-45).
 - 27 This, at any rate, is what is enjoined by tradition. Nowadays, however, while women still observe the custom, it is no longer common for young men to carry a betel bag or even to have one. Virtually all adults of both sexes, though, still regularly chew betel and areca.
 - 28 Marriage, too, is of course a stage in the life cycle, and for a woman, in particular, it can involve several rites which mark her transition from one group and one status to another. These are discussed in Chapter XVIII.
 - 29 Among the Rindi nobility, on the other hand, the task is assigned to a lineage of slave rank attached to the noble clan, which bears the name Uma Kikiru, 'Shearing House'.
 - 30 This is expressed with the phrases 'in order to attain the growth of the horns, the reddening of the tusks, the snowy white hair, the stooped age' (*patoma wāngu la tumbu kadu, la rara uli, la uwa kaka, la kaweda nākapu*).
 - 31 Fox (1968:300) states that among the Baä people of Roti, a forelock is left covering a child's fontanelle since this is where the soul is thought to reside.
 - 32 Horses, also, may have several *kawuluru*, the number, condition, and position of which indicate the animal's worth.
 - 33 *Wulu* (with a short *u*) is a reflex of Austronesian **bulu*, 'down', 'hair', 'feather' (Dempwolff 1938:34). It is not clear whether it is also related to *wulu* (with a long *u*), 'to create', 'wealthy', though this is an interesting possibility.
 - 34 This is made explicit in the context of a Kambera narrative recorded by Wielenga (1913:193n.).
 - 35 The association of the morning star and the time of its rising with divinity was mentioned in Chapter V. Here *marai romu* refers to the time — an hour or two before sunrise — at which the rice is consumed.
 - 36 With regard to my remarks just above concerning the significance of black, it is worth noting that the baskets in which the first rice is stored are called *mbola mitingu*, 'black baskets'.
 - 37 Intercourse between young and old, including parents and children, though, is on the whole quite free and easy, and even elderly people are not noticeably feared or deferred to. I also found it not uncommon for people openly to criticize or defy their elders. But this does not affect the principle that older persons, as the Rindi recognize, are owed respect by younger ones.
 - 38 The authority of the elder brother over the younger is shown by the designation of the former as 'the one who leads (by) the hand, who pinches the nose' (*malonda lima, maputu uru*), an expression which generally refers to a leader or superior. The birth order terms, which are straightforwardly descriptive, are given in Chapter XIV.

CHAPTER IX

- 1 The point that death is a transition accomplished in several stages has been made in one form or another by a number of early writers; see van Gennep

- (1960:3), Lévy-Bruhl (1966:276), Hertz (1960:28), and Rivers (1926:47).
- 2 Significantly, chin straps are otherwise worn only when one undertakes a long journey.
 - 3 The placing of gold in the mouth of the dead, sometimes along with pearls, is a very widespread practice among Hindus (Abbott 1932:207-08).
 - 4 *Yubuhu*, which may be glossed as 'wrapping', appears to be related to the synonymous word *yubangu*, which is cognate with *kayuba*, 'membrane, skin'.
 - 5 The bindings are called *karàndi*, which is the complementary term of *yubuhu*. The horizontal cords are specified as the 'bands for the legs, bindings for the knees' (*ruhu wihi, pai kambàku*), and the vertical ones as 'upward bands, ascending ties' (*boru dita, karàndi hei*).
 - 6 The container is called *manulangu*, from *manula*, 'skin, hide'. Occasionally, though, a wooden tub, or nowadays one of corrugated iron, is used.
 - 7 The knife, however, is carried on the left. The only reason I heard for placing both items on the deceased's left was that they should be kept together. It is perhaps significant, though, that the knife is usually placed closer to the corpse, thus just to the right of the purse or basket (see Fig. 4).
 - 8 On the funeral day a dead man's widow occasionally becomes hysterical, sobbing and babbling uncontrollably. On the one occasion I observed this phenomenon, the woman called out the names of dead persons whom she claimed to see. The condition, called *harànga* ('to be overcome by'), is thus said to indicate that she is communing directly with the deceased. It would appear that the woman is thought to be in some danger at this time, for others present seemed rather disquieted by the spectacle and attempts were made to return her to normal.
 - 9 Among the nobility, the playing of gongs and drums and the performance of special funerary songs and chants by the men commence at *pahadangu*. This should be continued from sunset to sunrise each night, and each time a horse should be slaughtered for the deceased. The songs are the special prerogative of the nobility in Rindi. Gongs and drums, as well, are played only at the funerals of persons of this class, and then only when the most elaborate form of mortuary ceremony is followed.
 - 10 Among the wealthy, it has become the practice to serve the corpse with coffee and sometimes, if the deceased was elderly, pulverized maize (*uta wataru*) — a food much favoured by old people as it requires little chewing — about midday.
 - 11 This suggests that the smell of the corpse indicates the presence of the deceased's soul. Similarly, it is a bad omen when an old corpse begins to smell again. In one case, this was attributed to a dead woman's co-wife having once failed to visit the house to attend the corpse as she should have done.
 - 12 Kruyt's (1906:269) explanation of the Indonesian rule enjoining silence at this time, namely that noise would reveal to the deceased's soul the way to his residence in life, cannot be valid for Rindi, since, like the corpse, the soul during this time remains inside the house.
 - 13 *Taningu* is a reflex of Austronesian **tanem*, 'to place in the ground, to bury, to plant' (Dempwolff 1938:130). One possible indication that burial is conceived of as planting is that the word for grave, *reti*, is also the class word for trees. On the other hand, this might just be related to the practice of tree-burial found in some other part of Indonesia. As I shall later describe, after the burial, the paraphernalia placed with the corpse in the house are suspended from a tall tree.
 - 14 All women who attend the funeral, regardless of their relation to the

- deceased, are expected to weep. While it is recognized and tolerated that close male relatives might be brought to tears when a death occurs, profuse weeping is disapproved of in men. It is described as *hi ànga*, 'weeping that is improper, pointless, disorderly, ineffectual'.
- 15 There are two main forms of grave in Rindi. With the simpler and more common sort the cavity is sealed with a stone, called the *ana dalu* (*ana*, 'child, small object, etc. '; *dalu*, 'inside'), which is laid flush with the earth. Directly on top of it is then placed a larger stone, the *dira lodu* mentioned just above. With the more elaborate form of grave, as built by the nobility and wealthy commoners, on the other hand, a third stone is mounted atop four or (among the higher nobility) six stone pillars or 'legs'; this type is called a *reti mapawihi*, 'grave with legs, limbs'. In this case the topmost stone is called the *dira lodu* while that which rests on the ground, atop the *ana dalu*, is designated the *lata pahàpa*, 'base, foundation for betel and areca (offerings)'. Sometimes the front, or 'head', of such a top stone is carved in the form of an animal's (usually a buffalo's) head, and among the higher nobility, exclusively, it may further be provided with decorated, upright columns (*penji*, also 'banner, flag'), inserted in depressions cut in the top surface at the front and the back of the stone.
 - 16 Sometimes, though not in every case I observed, the food was cooked on a fire in the village square. While some thought this was enjoined, I never got a clear explanation for it, and I think it may well be done only for practical reasons, the house being crammed full of people (mainly women) at this time.
 - 17 Among the nobility female slaves carry these items, while among commoners the task is assigned to a young close female relative (or sometimes two) — a granddaughter, daughter, or sister — of the deceased. Ideally, I was told, it would be a granddaughter. A sister performs the task only when the dead person is young.
 - 18 Unfortunately, I never had much chance to observe how consistently the function was assigned. Among the nobility, the duty is performed by a senior man of the clan Wanga (which is not affinally related to the noble clan). It should also be this man who binds the top of the corpse bundle when the deceased is prepared for burial, but on the one occasion I was able to observe the procedure the custom was ignored.
 - 19 The complementary phrase is *da mabatangu kajia*, which was explained to mean 'those who turn (their) backs'; *kajia* is the anatomical back. This expression accords with the idea of death as a reversal of direction, which I shall consider below.
 - 20 Kapita (1976a:168) also mentions this idea, but only with specific reference to the burial of a child.
 - 21 This practice is common in Indonesia (see Kruyt 1906:137). The association of the coconut with the human head, encountered elsewhere in the archipelago, is also found in eastern Sumba.
 - 22 I was told, though, that formerly persons of all ranks would partake of the meat, and I am not sure that it is absolutely forbidden to do so at present. It was said that slaves might occasionally still eat it, though I never heard anyone admit to this. Reluctance to eat the meat is thus probably due largely to it being considered substandard rather than prohibited. I also encountered the idea that only the animals killed on the funeral day should not be eaten. Savunese colonists from Melolo sometimes attend more lavish Sumbanese funerals to help themselves to the carcasses, a practice to which the Rindi have no objection.

- 23 When a wooden tub is used, however, it may be kept and reused.
- 24 This might be compared with the Rotinese (Termanu) practice of washing the hands of the deceased's close agnatic kin in coconut milk to remove the 'pollution of death' (Fox 1971b:242).
- 25 In this regard I was given the phrases 'oil of rice and maize, dew of the sky, coconut oil of the land' (*mina uhu mina wataru, mburungu la awangu lonahu la tana*).
- 26 Among the highest nobility, noble wife-givers further provide a female slave, called *papanggangu*, a term which also denotes the slave attendants who guard a noble corpse. The woman may be given on the funeral day or at the final mortuary ceremony (*pahili mbola*), when affines further exchange prestations, but not, I was told, on both occasions. She later marries a male slave of the deceased's clan.
- 27 Kapita (1976a:183) says the goods given by the dead man's clan in return for those brought by affines (both wife-givers and wife-takers) in eastern Sumba are called *wàla lima*, *hupu lunggi*, which he glosses as 'finger of the hand, end of the hair'. But I never came across this expression in Rindi (also, 'finger' in Rindi is *wua lima*).
- 28 At one larger commoner funeral I attended, 37 pigs were slaughtered. Of these, 18 were provided by the dead man's agnates, and 23 by co-villagers and close affines (in this case, all wife-takers). There were four animals left over.
- 29 Kapita (1976a:66, 184) mentions the same rule. Interestingly, however, in many cases I recorded the mourning was formally ended four days after the burial, while in others it was two, and in one case seven. But since it is possible to extend the period by a further four days this latter instance can be said to accord with the stated rule.
- 30 Whereas among commoner clans the pig is eaten, the nobility do not partake of it, though their slaves may do so; for like the horses and buffalo slaughtered at the funeral, the animal is considered to belong to the dead. Another pig is thus killed to provide a meal for the nobles.
- 31 The identification of death as hot and life as cool is further suggested by the use of the terms *luri* (living) and *meti* (dead) to describe fresh water and boiled water, and unforged and forged metal, respectively.
- 32 'But the ideas relating to the fate of the soul are in their very nature vague and indefinite; we should not try to make them too clear cut' (Hertz 1960:34).
- 33 Interestingly, this phrase also applies to a man who has yet to discharge fully the bridewealth for his wife, and so is for a time obligated to both his own clan and that of his wife's father.
- 34 This marginal area is called the *kambu kiri purungu*, *lumbu pamangahungu* ('the belly, the start of descent, the watered place beneath'), which is the same phrase as applies to the area just outside and below the chief village in Rindi. This shows, then, that the land of the dead is in this respect conceived to be identical to the land of the living.
- 35 In this regard, death is described with the phrases 'to assume a different form like the river shrimp, to change skins like the dry land snake' (*njulu la kura luku, halubu la mându mara*).
- 36 When the person normally resided or died in another building, the rite is performed both there and again in the compartment at the left front corner of the clan's ancestral house, in which building the corpse awaits burial.
- 37 *Mayela* is a species of hardwood tree said to grow in abundance in the land of the dead.

- 38 Hertz's remarks that '...the final ceremony always has a pronounced collective character and entails a concentration of society', and that 'in establishing a society of the dead, the society of the living regularly recreates itself' (1960:71, 72), are pertinent here. I would also judge van Gennep's statement that '...those funerary rites which incorporate the deceased into the world of the dead are most extensively elaborated and assigned the greatest importance' (1960:146) to agree with what I found in Rindi.
- 39 Cfr. Hertz (1960:31-2): 'We are thus justified in believing that, normally, the time which elapses between the occurrence of death and the final ceremony corresponds to the time judged necessary for the corpse to reach a skeletal condition...'
- 40 Interestingly, though the rite concerns the deceased of both sexes, *mbola*, 'basket', actually refers to a sort of betel container used exclusively by women. I noticed also that the Rindi would often call the betel containers of the deceased *kāpu*, which also denotes a sort used only by women. The men's betel purse is called *kalumbu*. These usages might therefore be construed in relation to the symbolic femininity of the dead, a theme I discuss just below.
- 41 As I shall elaborate later, dogs are used in various rites which have in common the theme of removal of impurity.
- 42 Indonesian usages and ideas relating to bad death have been extensively reviewed by Sell (1955). The distinction of good and bad death is widespread in this part of the world.
- 43 *Ānga*, a word with a great many distinguishable senses in English, often implies that something is done without purpose or to no avail.
- 44 *Mbana*, 'hot', itself has the sense of 'violent', 'excessive', 'tremendous', but *harabāndangu* is rather more specific in this regard.
- 45 Actually, the last two phrases (*meti njadangu*, *meti wenangu*) also refer to a particular category of hot death. *Njadangu* and *wenangu* both mean 'to roam, wander', hence the phrases denote the fate likely to befall vagabonds, thieves, and murderers, who characteristically wander from place to place. Formerly such persons were put to death and buried without ceremony outside the village. The same was done with witches and the corpses of enemies. Kapita (1976a:165) thus glosses *meti njadangu* as 'neglected death'. He also records the expression 'those given a grave of cactus and covered over with a thorny plant' (*na paparetingu kalàla*, *na papanulangu hambuli*), which, he says, refers to the method of burying such persons.
- 46 The earth is thus evidently thought to be offended by the death. The rite is specifically concerned with the earth. Thus, I was told, if someone is killed by a crocodile, though this involves blood loss, it need not be performed if the attack occurred in the water.
- 47 While in Rindi the corpse is buried inside the village, in some parts of eastern Sumba it is apparently buried outside (see Kapita 1976a:165).
- 48 This is also done at the burial of an insane person or a leper. Death from leprosy and the death of a madman, however, are not considered hot (or 'bad') deaths in Rindi, though the former is in some other parts of Indonesia.
- 49 In Rindi this function is assigned to the clan Karambu. Formerly the clan maintained a special house in the chief village, Parai Yawangu, on the verandah of which, I was told, the corpses of noblemen and their slaves who had suffered a hot death were placed before burial. The house has since been relocated close to the oldest, ancestral house of this clan in another village.

- 50 Kapita (1976a:165) says that among the nobility, the bones of the deceased are re-excavated and ritually cooled, after which they are re-buried with the usual ceremony. I never heard that this was done in Rindi.
- 51 Or 'reddening of the leaves, death of the spines' (*rara ru, meti pàpa*).
- 52 It is thus commonly said of a wrong-doer 'he will not go through' (*nda na malundungu*), meaning that he will be punished with an early death.
- 53 *Mata* here refers to that part of a fruit to which the stalk is attached; if this should split, the fruit would fall to the ground.
- 54 Kapita (1976a:64, 170) says that in former times a very old person's death was not an occasion for mourning but was celebrated with dancing, singing, and other festive activities. I never heard this in Rindi.
- 55 In ritual speech a child who dies before weaning is called *mahawurungu*, 'something that flies (has flown)', thus indicating that the soul has flown away (see Chapter IV). *Mahawurungu* is also the word for 'bird', 'flying creature'.
- 56 If thick, heavy cloths were used the parents would follow the child in death. I remarked on the association of 'heavy' and 'light' with adults and children respectively in the previous chapter. This requirement seems to be related to the idea that an unweaned child is still closely attached to its parents, particularly the mother.
- 57 Van Gennepe (1960:52) notes the 'prevalent idea' that '...unborn children first live in fountains, springs, lakes, and flowing water', which is thus somewhat reminiscent of the fate of deceased infants in Rindi. They do not say, however, that an unborn child comes from a watery place, or, indeed, that a dead child returns to the realm of the unborn.
- 58 The *kawarungu* built over the grave of the last government Raja of Rindi, who died in December 1960 and was buried in the early sixties, was still (nominally) in existence during my stay there in 1975-76. Before I left there was still no definite plan formally to remove it.
- 59 It was said that in the past some of these attendants died and gave birth while still resident in the shelter.
- 60 The commoner clan Mahora in Rindi is permitted to use one or two *papanggangu* at the funerals of members of its senior line, but this is a special privilege granted to them by the nobility (see Chapter XI, Section 4).
- 61 Sometimes, I was told, the horse and cockerel also become unconscious. This reputedly happened at the funeral of the last raja of Rindi, and the horse thus had to be carried to the grave on two stout bamboo poles. Umbu Hina Marumata, the director of a high school in Waingapu, reported to me in a letter (dated 31st January 1979) that this also occurred at the funeral of a nobleman which he witnessed in Parai Liu, Kampera in December 1978. Twenty men were required to carry the horse.
- 62 It is a common practice to refer to or address a former *papanggangu* with the title of his ritual function, e.g., i Lunggu Manu (Chicken Bearer).
- 63 The Rindi view of the land of the dead is very similar to that which Schärer (1963:142) describes for the Ngaju of Borneo.
- 64 Another expression that refers to the death of a nobleman is *tanduluru awangu, tanahaku tana*, which seems to mean 'opening up of the sky, collapsing of the earth'.
- 65 It is possibly also significant in this regard that textiles, in which the corpse is wrapped, are categorically feminine goods.
- 66 Another common, though rather obscure, expression referring to the vital essence carried downstream by the river is 'cinnamon bark, oil of the *kandora* fruit' (*tàda manggalawa, mina wua kandora*). Kapita (1974) describes

- kandora* as a tree growing near the river's edge, the fruit of which is used to make resin. In Rindi the first phrase was said also to refer to the uterus and the second to its 'male counterpart'.
- 67 While I was told that it was the souls (*hamangu*) of the dead which are thus washed out to sea, others denied this, claiming instead that this concerns only the deceased's bodily fluids. Similarly, in Kédang it is the corpse and not the soul which ends up at sea in the form of a fish, while the soul returns to God (Barnes 1974:203). It should be noted, however, that in this context the Rindi usually speak simply of the *mameti*, 'the dead', which can refer equally to the corpse and the soul. There is no special word for 'corpse'.
- 68 As noted earlier, the Rindi regard rain that comes from the downstream direction as 'bad' or 'hot' rain, which is harmful or, at best, of no benefit to plants or humans.
- 69 In a version of this itinerary recited at one of the component rites of the *pahili mbola* ceremony performed by a lineage of the noble clan in Rindi, the soul is described as travelling to the Base of the Sky directly after reaching the clan's *pahomba* shrine at Pataningu Manu near Umalulu. This variation is thus consistent with the identification, noted in Chapter IV, of these shrines with the first place of settlement of the clan ancestors on Sumba. Another place where the soul always carries on leaving or returning to the house is the yard altar (*katoda kawindu*), which as I have shown is also closely associated with the *pahomba* shrine.
- 70 While there are usually said to be eight levels of earth and sky, as I have remarked elsewhere, even numbers, especially four and its multiples, are regularly substituted for one another in ritual contexts. In this instance, therefore, four and eight appear to be symbolically equivalent.
- 71 According to another version of the soul's journey, however, after reaching the Base of the Sky, it simply returns to the estuary of the Kambaniru river and from there proceeds to the Head of the Earth and the land of the dead, while in the shortest accounts I recorded the soul does not go to the Base of the Sky at all before reaching the land of the dead.
- 72 Further on, Hertz (*ibid.*), suggests that birth, too, involves such changes; so there is the question of why the funeral and the marriage ceremony in Rindi more closely resemble one another than either do other transition rites. In this regard it may be relevant that with birth the initial removal of the child from the realm of the unborn, rather like the final incorporation of the dead into the afterworld, takes place only in thought, and while it is reflected in rites, it does not involve an actual, physical removal of the principal from one place to another. The initiation of youths, on the other hand, does involve such a removal, but this is only temporary.
- 73 Since *yera kawini* is properly the spouse of *yera* (WB, MBS), moreover, it might be speculated that in the afterworld a man becomes in some way the son of his MB. It may be worth noting in this respect that among the patrilineal Iatmul of New Guinea a dead man's MB claims him as 'in some special sense a member of the maternal clan' and in the afterworld a man's ghost assumes the names he has been given by his MB (Bateson 1958:9).
- 74 On proceeding to collect a bride, a wife-taker should depart from his own village and enter the wife-giver's village by way of the respective downstream gates; but when he leaves to return home the upstream gates of the two villages should be employed. It is interesting, therefore, that the dead, when they come to visit the living, were said to proceed in precisely the same manner.

- 75 Red is thus not associated specifically with bad death or the destination of the souls of persons who have died a bloody death, as among the Mantra of Malaya (Skeat and Blagden II, 1906:321-22).
- 76 A couple of other particulars might be noted in this regard. The *loba* tree, the leaves and bark of which are used to make red dye, grows in abundance in the land of the dead. A food favoured by the dead is (*uhu*) *kani*, millet (*Panicum verticillatum* L.), the ripening ears of which are red. For this reason some people claim not to eat it. The ridge of hills said to connect the chief village of Umalulu with the land of the dead, the 'ridge of the ancestors' (*palindi marapu*), is alternatively known as the *kani* ridge.
- 77 This association is shown, for example, in the expression *bara eti*, 'white livered (hearted)', meaning 'pure of heart, mind', 'bearing no malice', and 'sincere'. *Bara* can also mean 'clear, colourless'. New (dried) thatch before it becomes weathered and discoloured is *bara*. In opposition to black, on the other hand, white connotes immaturity and incompleteness (see Chapter VIII).
- 78 Red seems to be more generally associated with the ancestors. Thus the phrase *lotu marapu*, 'ancestor sun', describes the red glow of the sunset; and the ancestor is said to ride on a red horse.
- 79 I did not find any explicit rule concerning the number of cloths that should be used to wrap an adult corpse, though on the one occasion I was able to make an accurate count, they were of an even number.
- 80 With reference to the marked association of uneven totals with various fixed periods of time, Barnes (1974:167) remarks that 'uneven numbers occur as a structural property of duration' in Kédang.
- 81 One possible exception to this is the annual period of restriction and quiet (*wula tua*), which is ambiguous in terms of the division of the two major seasons and is considered a time of danger and ill health. This period comprises three named parts: the waning half of one month (ca. May or June), the whole of the following month, and then the waxing half of the next month. Even so, the total duration of the period is thus still just two lunar months.
- 82 Barnes (1974:168, 178) records a similar association for Kédang, where odd numbers are described as the numbers of life, and even ones as the numbers of death.
- 83 The fact that, by a process of division, fourteen is here reduced to an uneven number is significant in relation to the preference for four and even multiples of four.
- 84 I refer here to the practice of some clans, mentioned in an earlier footnote (see Chapter VII, section 1), whereby the 'male' and 'female' portions of betel and areca offered to the ancestors on important ceremonial occasions include eleven and nine pieces of areca nut respectively.

CHAPTER X

- 1 By referring to these groupings as classes I do not mean to suggest that they are necessarily comparable in every respect to the economic classes of modern western societies or to other historical forms of social division that have been designated by this term. In accordance with the general approach of this enquiry, then, my intention here is only to describe the system in Rindi in such a way as to show its relation to other aspects of their social and conceptual order.

- 2 Blust (1972:166-69) notes that while reflexes of Austronesian **Cau* (e.g., *tau*), 'human', never appear with the meaning of 'slave', those of **qa(CIT)a* (e.g., *ata*) can appear with both meanings. To account for this he suggests that the latter word originally meant 'outsiders, alien people', which would thus include the sense of 'slave', and in some cases has become generalized to mean 'human, man'.
- 3 Persons classified as *ata* (slaves) constitute nearly 38 per cent (1,313) of the total Rindi population. Over 90 per cent of them are attached to the noble clan, while the rest are divided among ten descent groups of commoner rank (see Appendix III).
- 4 Kapita (1976a:48) states that when the ancestors (*marapu*) of the eastern Sumbanese arrived on Sumba they were accompanied by slaves.
- 5 Fischer (1952:161-2) suggests that the generally good treatment of hereditary slaves in traditional Indonesian societies can best be understood by considering them as the descendants of an aboriginal population subjugated by later immigrants (see also Ruibing 1937:7).
- 6 The offspring of slave women and noblemen are called *ana kala wihi*, 'children of leg supports'. The term derives from the expression *kala wihi lemba lima, ata piti, ata hadangu*, 'leg supports, arm rests, slaves who fetch, slaves who rise', which refers to the slave class in general. Such persons are not recognized as the legal offspring of their noble fathers, and, contrary to Kapita (1976a:41), who says they can be considered equal to commoners, I found they were treated no differently from other *ata bokulu* in Rindi.
- 7 Though I found one mention in myth of a higher ranking captive (in fact an ancestor of the Rindi noble clan) being ransomed, it is not clear whether this was ever a regular practice. There is also no institution that could be called debt slavery in Rindi.
- 8 Slaves do not, however, address their masters with the reciprocal *aya*, 'elder sibling, person'.
- 9 Another expression in which *eri* and *aya* are conjoined to refer to a social unity is *hupu mapaeringu, hupu mapaayangu*, 'junior most extremity, senior most extremity', which denotes all members of a single clan.
- 10 The terms refer to both the slave and the form of naming. While in some parts of eastern Sumba *ngara* is more generally used with the sense of 'name', in Rindi it has only these two referents. The general word for name there is *tamu*, which as noted also means 'namesake'. The original Austronesian word for 'name' given by Dempwolff (1938:12) is *(^o)*ag'an*, of which *ngara* is apparently a reflex.
- 11 This form of designation is called *tamu kajangu*, 'sheltered name'. When a number of deceased noblemen are mentioned together, as, for example, when offerings are made to the dead, the titles are grouped in pairs. A single utterance then comprises the names of four slaves, which thus refer to two noblemen. Deceased noblewomen, however, are never designated in this way; they are equally served, I was told, by the offerings dedicated to their husbands.
- 12 The term *ata memangu*, however, is also equated with *ata bokulu*, i.e., the category of hereditary or higher ranking slaves as a whole. (Though *ata memangu* is the term most frequently given for hereditary slaves in the Dutch literature, it is not, in fact, often used in Rindi.) In this and other contexts, *memangu* seems to have the sense of 'inherent' and 'permanent, fixed'.
- 13 I was also told a woman's *ngara hunga* cannot act as the bride's substitute (*mamoha*) at her marriage; another female *ata rànja* or a commoner

- woman must serve in this capacity. The rule calls to mind, then, the fact that one sort of female *papanggangu*, the 'one who wears the hat', clearly resembles a *mamoha*, and the apparent symbolic identity between a bride's substitute and a corpse.
- 14 A life slave is buried in a smaller grave, sometimes placed in front of that of his master.
 - 15 This agrees with Fischer's (1952:161) statement that 'Whenever one hears of slave sacrifice [in Indonesia], this never refers to hereditary slaves'.
 - 16 *Maràmba* is apparently formed from the relative pronoun *ma* plus *ràmba*. Although I could find no independent meaning for *ràmba*, a possible derivation of the word is Austronesian **la(m)bak*, 'to spread out (intr.), to gain ground' (Dempwolff 1938:100), one reflex of which is Indonesian *merambak*, 'to multiply, spread in all directions' (Echols and Shadily 1963, s.v. *rambak*). *Maràmba* might then refer to the extensive political influence of the noble class.
 - 17 One expression used to denote the nobility (as a class) in ritual speech is *hundarangga*, *ru patola*, which comprises the names of especially fine imported silk cloths (see Indonesian *dewangga* and *petola*), originally from India, which are now possessed almost exclusively by the nobles. Noting that it was the practice of the Javanese emperor of Majapahit to present such cloths to provincial rulers, Kapita (1976b:16) suggests that this is how the Sumbanese nobility might have come by them.
 - 18 The place where she descended to earth is known by several pairs of names, one of which is Manggawa Wula, Manggawa Wai Jilu. *Wula(ngu)* is 'moon', while *manggawa* denotes a spatial or temporal interval. Interestingly, *manggawa wulangu* also refers to the phase of the lunar month when the moon is not visible, at which time, the Rindi say, it rises with the sun and accompanies it across the sky. (I was told that this is an indigenous idea.) Perhaps, therefore, the woman's birth is thought to have involved a conjunction of the two heavenly bodies.
 - 19 The apparent association of the nobility with the sea, which this phrase might suggest, is considered just below.
 - 20 Here I follow the most general version of the myth. I also recorded two other versions, specific to Rindi, according to which Umbu Mbadi himself descended to Wai Jilu with the first noblewoman, who was his sister. She then married the ancestor of Kaliti, while, following one version, Umbu Mbadi later married their daughter, thus his sister's daughter. There can be little doubt, however, that these variants, which clearly are meant to proclaim the absolute superiority of the Ana Mburungu nobility, represent secondary modifications of a more basic tradition.
 - 21 Since 'red crocodile' was said in Rindi to refer to the male of the species, this phrase might be an expression of the symbolic maleness of the noble rulers (see Chapter XI, Section 1).
 - 22 These include 'the squat *wudi* tree, the drooping *wàngga*' (*wudi pandaku*, *wàngga mbewa*), 'the enshrouded *wunggututu*, the *kadauki* with many limbs' (*wunggututu mamaringingingu*, *kadauki dangu nyuka*), and 'the *karuku* with roots growing from the base (?), the *wàngga* with arching boughs' (*karuku mapalipi*, *wàngga mbewa lai*). The highest ranking, ruling nobility (*maràmba bokulu*) are also called *maràmba pingi ai* or 'tree nobility' (*pingi ai* is 'tree').
 - 23 These phrases refer to the means by which a buffalo is tied up for slaughter. I am not quite sure how best to translate *liku uru watu*. *Uru watu* is 'hole in a stone', but *liku uru*, which refers generally to a leader, would usually mean 'nose rope' (*uru* is 'nose'), i.e., the means by which

- an animal is led. An expression sometimes used in place of this is *nggàlaru kaliyangu*, 'loop, nose ring of brass'.
- 24 The statement by Roos (1872:9) that impoverished nobility are not respected, accords with what I found in eastern Sumba. The relation between wealth and class standing is further discussed in Section 4 below.
 - 25 I did not, however, encounter in Rindi the idea which Kapita (1976a:43) mentions, that to use a nobleman's proper name would cause him illness or death.
 - 26 Curiously, while they are assigned *ngara hunga* names, these are rarely if ever used in Rindi for persons of the higher nobility, though they are so used in other parts of eastern Sumba. In this way, then, the higher nobility are distinguished from the lower nobility in Rindi; and *umbuna i*, 'lord of' (the form of the *ngara hunga* title) has there become a standard expression denoting persons or groups that cannot claim pure noble descent.
 - 27 In other parts of eastern Sumba men belonging to the higher nobility are similarly addressed as *tamu umbu*. The reason this title is not used in Rindi, I was told, is because *tamu* might be confused with *wotamu*, 'your penis'. Interestingly, *umbu* itself (in this case often pronounced with a longer initial *u*), like the less ambiguous *umbu rara* (*rara* is 'red'), can also mean 'penis'.
 - 28 Interestingly, one expression used to refer to a deceased nobleman, is 'gold at the tip, precious metal in the water' (*marara la kapuka, àmahu la wai*).
 - 29 Following another traditional arrangement, the nobility may obtain, by paying a bridewealth to her father, a commoner woman whom they then give as a wife to a commoner client, or to an hereditary slave. As the commoner does not make a further marriage payment, the woman then becomes, in effect, a slave.
 - 30 Esser (1877:163) states that the nobles received a payment of gold and silver at the value of Dfl.20 and Dfl.1 respectively for each marriage, whether it involved freemen or slaves.
 - 31 Whether they contribute bridewealth or counter-prestation at noble marriages depends entirely on whether the noble clan is taking or giving a wife. This applies also to client commoners; though they are, in a sense, wife-takers of the *maràmba*, they contribute to the marriage prestations in the same way as do their slave affines. At noble funerals, high ranking commoners usually bring cloths or one or two pendants, in which case the gift is not reciprocated. When a commoner clan has taken slave wives from the nobility for its own male slaves, however, it provides the full portion of goods (see Chapter IX, Section 3), and receives from the nobles goods of the opposite sort.
 - 32 Though evidence is mostly lacking (and in any case it lies outside the scope of this enquiry to speculate on the possible origins of the system), it is yet worth recording the conjecture that the slave class, in particular the hereditary slaves of the nobility (*ata bokulu*), have gradually replaced commoners as the 'lower group' in an originally dually divided system, perhaps in a way similar to that suggested by Schärer (1963:45-46) in the case of the Ngaju. I have noted the idea that here were originally only two classes, nobles and commoners, in eastern Sumba. The system could thus have become manifestly tripartite while yet retaining certain dualistic features or tendencies.
 - 33 It is relevant in this regard that all the lower ranking wife-givers of the Rindi noble clan, in fact all their affines, reside in other domains and therefore are not politically subject to them. The groups thus come into

- contact only on occasions that specifically concern alliance, such as marriages and funerals, when the superiority of the wife-giver is contextually assured.
- 34 According to de Roo (1890:580), the eastern Sumbanese deliberately restrict the number of *maràmba bokulu* by the practice, in plural marriages, of marrying only one woman of this rank. In my experience, though, this is simply a function of the limited availability of such women. In Rindi there is no rule against taking more than one *maràmba bokulu* wife, and I encountered several cases where nobleman had done so.
 - 35 If a man dies when his children are still young, his goods pass to his eldest surviving brother, who then acts as trustee until the sons are adult. Daughters do not inherit from their fathers, except, of course, when there are no adult men left in the lineage.
 - 36 The union was therefore described with the phrases 'to relieve the knees, to provide a ladder' (*pajàmangu kambàku, wuangu panongu*), indicating that the wife-taker is hereby enabled to rise to the rank of his wife-giver.
 - 37 Several Dutch writers (Roos 1872:3; de Roo 1890:579, Nooteboom 1940:30) have also mentioned this possibility. They disagree, however, as to which descendants of the original marriage are the first to attain the higher rank. I never heard in Rindi that such a union is expedited by abduction, as de Roo (1890:579) claims.
 - 38 It is also theoretically possible, then, for a slave lineage to rise in rank to nobility, though Wielenga's statement (1909b:303), according to which this can be achieved in 'a few generations', is probably an exaggeration. It is also worth noting here how class inter-marriage in eastern Sumba contrasts with mixed unions in the Indian caste system, as described by Tambiah (1973). Thus whereas in the Indian case, higher standing can be achieved by continually marrying sisters and daughters to men of a higher *varna* (ibid.:222), in eastern Sumba this is done by marrying men to women of higher rank. As Tambiah (ibid.) notes, therefore, 'An essential feature of the caste system is that men cannot *increase* the status of their children through their own marriage...'. In eastern Sumba, on the other hand, they clearly can.

CHAPTER XI

- 1 Though none of these terms fits exactly the distinctions under which they are subsumed (see Hocart 1970:163), they should at least serve as a convenient guide in describing the main features of the two types of authority.
- 2 It is worth recalling, for example, the fact that the nobles in Rindi do not themselves engage in priestly duties but have slaves or commoners do this for them. I also mentioned (see Chapter IX) that on ritual occasions the priest is always served with food first, even before noble persons in attendance. Otherwise persons are served according to their rank. Thus the order of precedence observed in religious contexts is different from that which governs purely secular ones. As noted, there are several other occasions when a person in a special, marginal or transitional state (such as that which a priest engaged in rites can be said to occupy) is given preferential treatment which contrasts sharply with his normal (secular) standing.
- 3 *Ratu* is related to a great many words in Austronesian languages which denote some sort of leader or dignitary (see, e.g., Indonesian *ratu*, 'monarch',

- and *datuk*, a widely applied honorific). Dempwolff (1938:39) gives the original form as **datu*, 'clan, tribal chief'. According to Wielenga (1909a: 307; 1917:26, 48), the western Sumbanese cognate *ratô* applies both to secular rulers ('princes') and religious authorities ('priests'); and from this both he (1909c:372) and Lambooy (1927:233) argue that the *ratu* of eastern Sumba were the original rulers, who retained only the spiritual leadership of the people when they were later replaced by intruders — the present *maràmba*. However, while there is some evidence to suggest that the *ratu*'s authority was once less restricted to purely religious matters than at present, it does not of course follow that the present system of dual leadership came about in the way these authors claim. As van Dijk (1939a:509) points out with regard to Laura, moreover, there the term *ratô* does not apply specifically to hereditary leaders ('princes' and 'priests') but to any person who, through birth or wealth, occupies a position of prominence.
- 4 The association of the elder with spiritual authority in eastern Indonesia, however, is not invariable, even, apparently, on Sumba. Thus Kruyt (1921: 543) reports that in Lamboya, in western Sumba, the 'sacred objects of the ancestors' are guarded by the younger brother of the ruler.
 - 5 The details of this myth are remarkably similar to those of a Rotinese myth recorded by Fox (1968:131, 156) which concerns how the ancestor of the ultimate authority in customary and religious matters, the first man to inhabit the domain, was tricked by the ancestor of the present ruler into surrendering his secular authority. Indeed, the theme of power being deceitfully wrested from older groups by later arrivals is common in eastern Indonesia. In this case, however, Kàbalu, who occupies the same position in the myth as does the ancestor of the Rotinese religious authority, was driven from Umalulu altogether, while the deceiver was the ancestor of the religious leader (or, by another interpretation, the ancestor of both the religious and secular leaders).
 - 6 This portion of Umalulu mythology also indicates a former unity between Umalulu and several neighbouring domains. This is further expressed in the claim that the *ratu* of this district originally exercised dominion over the entire territory extending from Watu Mbaka in Kampera to the river Wai la Kaba in Wai Jilu. Unfortunately, however, limitations of space do not allow me to outline this tradition here.
 - 7 It is perhaps worth stressing here that, apart from this alliance connexion, Palai Malamba is superior to Watu Pelitu only with regard to descent and temporal precedence (thus in the same way as the *ratu* are superior to the *maràmba* in general). As I shall later describe, therefore, Watu Pelitu is not politically subordinate to the senior noble clan and, in terms of class, is of just as high a standing.
 - 8 In 1975 the only building still standing and occupied in the Umalulu chief village was the senior house of the *ratu* clan Muru Uma.
 - 9 Because of this, the house, roofed with coconut boughs and crudely constructed, was purposely not built to last.
 - 10 Cf. Cunningham (1965:371) who makes the same point with regard to Atoni diarchy.
 - 11 Actually, the two outer sections of the village comprised further named divisions associated with specific clans, but these need not concern us here.
 - 12 In this capacity, Paraina Bakalu possibly acts as a representative of Palai Malamba. This is further supported by the fact that this clan is one of the four whose names are used to refer to Palai Malamba in formal speech. Were this so, the functions of the *paratu* would then evidently entail a

- unification of the complementary powers of *ratu* and *maràmba* in a way most appropriate to this ritual context.
- 13 The place of Marapeti among the *ratu* clans seems to derive from the part played by its ancestor in the construction of the first *uma nda pataungu*. According to myth, it was this personage who, by means of a trick, managed to complete the original building in the face of obstruction from a representative of one of the aboriginal groups that formerly inhabited the domain.
 - 14 In this capacity Ongga is known as the *ratu kaborangu*, 'bold *ratu*', and the 'sharp lance, thick shield' (*nimbu tara, temi timbi*).
 - 15 Some early Dutch reports (e.g., Wielenga 1909c:371-2) suggest that the designation *ratu hàpi* and the practices described above applied to the *ratu* as a class. While this is clearly not the case in Umalulu, it possibly agrees with the former situation in some other parts of Sumba, where it seems the only party accorded the title of *ratu* was indeed a figure with the attributes of the Umalulu *ratu hàpi*. Moreover, since the four *ratu* represent a symbolic unity, the *ratu hàpi* is perhaps better considered as an aspect of the *ratu*'s (spiritual) power rather than as an independent office. Interestingly, Kapita (1976a:40) cites the notoriety of the *ratu hàpi* as the reason why the position of the *ratu* in general has, as he claims, gradually declined in eastern Sumba. In Rindi there was once a segment of the clan Luku Tana whose members, by virtue of the nature of the *marapu* ancestor whose relics they guarded, were similarly regarded as witches; and I was also told that this group formerly held a position in the domain analogous to that of the *ratu hàpi* in Umalulu. It seems, however, that they were never formally accorded the title of *ratu*.
 - 16 This was what I was told in Umalulu. Kapita (1976a:130), referring to the same institution, however, says that only one person was spared. A spouse would then be provided from among the slaves of Palai Malamba or Watu Pelitu respectively, according to whether the person were a man or a woman. This arrangement thus seems to reflect in an interesting way the relation of these two clans as wife-giver and wife-taker.
 - 17 This possibility is reminiscent of the point noted by Coomaraswamy (1942:2, n. 2) with regard to Hindu notions of authority, that the *brahma* is both the *brahma* and *ksatra* so that '... the Supreme Power is a royal as well as a priestly power...'
 - 18 Those of Palai Malamba (here listed as they are recited in ritual speech) are Menggitu, Paraina Bakalu, Pakilungu, Kamandalorangu; those of Watu Pelitu are Katoraku, Ru Rara, Palamidu, Watu Bara.
 - 19 As evidence of the respective association of the elder and younger brother with the earth and sky in eastern Sumba, van Wouden (1968:30) cites a Tabundungu myth reported by Lambooy (1927:233) which relates how the ancestor of the ruler of that district encountered four *ratu* when he descended to Sumba from the sky. I would argue, however, that, like the Umalulu myths, this tradition indicates no more than that the *ratu* were the earliest to arrive in the various territories.
 - 20 In Hindu theory, too, the 'priest' (*brahma*) and 'king' (*ksatra*) are respectively connected with the sky and the earth and, contextually, are represented as male and female (see Coomaraswamy 1942:1-2 et seqq., 50).
 - 21 The longer expression thus provides another instance in which *ina-ama*, the parent terms, have reference to a party who is in some way superior or holds a position of authority. The gloss 'owner of the land' for *mangu tanangu* is mostly a convenience. As I have indicated previously, the word

- mangu(ngu)* can indicate a rather closer relationship between two entities than what we would ordinarily understand by 'ownership'. A better translation would thus perhaps be 'one who has the land' or 'who is with the land'. Like *ratu*, moreover, the term refers more to a clan than to a particular individual or functionary.
- 22 Van Wouden (1968) shows this to be the case in western Sumba (p. 28), on Roti (62, 64), Seram (75), Larantuka (82), and Kei (141). On Kei the ruler belongs to the aristocracy while the 'lord of the land' is of the lower class (141). The figure of the 'lord of the land' in eastern Indonesia has also been reviewed by Scholz (1962).
 - 23 The status of *mangu tanangu* in this sense entails having a *pahomba* shrine within the territory (see Chapter IV).
 - 24 The relation between the *mangu tanangu* (in both applications of the term) and the groups with whom they share the land is expressed with the phrases *duangu tobu uhu*, *kaba waingu*, 'to share rice bowls and drinking vessels', and the ancestors (*marapu*) of such groups are referred to as *makaraba tana ngangu*, *tana ngunungu*, apparently 'those who use the earth as eating and drinking troughs'. There is no term for 'tenant', though an individual cultivator, whatever his status, is called *mangu wokangu*, 'owner of a field'.
 - 25 After the disappearance of Rindi, the rule continued to be enforced by the noble lineage Uma Wara, which holds a 'replica' (*pakapukangu*, from *kapuka*, 'tip') of the relics of the Rindi clan ancestor; and since Rindi was also responsible for overseeing the rites at the river mouth altar (*katoda mananga*), Uma Wara has taken over this duty as well. The lineage is further responsible for the annual rites at the altar at the downstream gate of the chief village. Accordingly, the principal house of Uma Wara is located at the downstream extremity of the village.
 - 26 Here, of course, I refer to the office where, as in Rindi, it is not combined with that of *maràmba* or *ratu*. Thus Roos (1872:4-5) notes that the *mangu tanangu* of eastern Sumba have no influence in the 'affairs of government' unless they are simultaneously *maràmba bokulu* (i.e., high ranking or ruling nobility).
 - 27 Other expressions used to designate the *mangu tanangu* include: '(those) who burn the grass (so it may become) green, (and) scoop up the clear water' (*na mahulu rumba muru*, *na matimba wai kahingiru*), and '(those) who possess each handful of earth, each blade of grass' (*na matanangu haupu*, *na marumbangu hawàla*).
 - 28 The lineages are named after their principal houses (*uma*) (see Chapter XII).
 - 29 The woman was called a *mamoha*, a term that otherwise refers to a bride's substitute, and she was obtained, with a bridewealth, from another domain. However, she could not (formally) marry. This situation suggests, then, that the woman may have been conceived to be the bride of the ancestral deity honoured in this house.
 - 30 Thus instead of the usual three sets of house posts (*kambaniru*, see Fig. 1), this house is provided with only two sets (the *lundungu* and *hawunjilu* posts, numbering four and twelve respectively). The lowest part of the roof is then supported by stout poles (*punduku*) inserted between the raised floor (and verandah) and a beam placed beneath the eaves.
 - 31 While these groups are said formerly to have served the nobles as military allies and to have provided them with warriors, they are by no means the only commoner clans to have done so.
 - 32 Palai Malamba, for example, is thus called Menggitu, the first mentioned of the quartet Menggitu, Paraina Bakulu, Pakilungu, Kamandalorangu.

- 33 The six actually form part of a group of eight which also includes the noble clan plus one other. Since the sextet comprises three pairs, this total can be regarded as uneven or incomplete. Evidently, then, it is rendered complete by the connexion of the six clans with Ana Mburungu.
- 34 Thus when I once asked a Rindi nobleman why the six clans should not be called *paratu*, he replied 'we do not speak of *ratu* in Rindi'. By contrast, another informant, an elderly ritual expert who was not of the noble class, stated not only that these groups were properly called *paratu*, but that they could be regarded as the *ratu* of Rindi.
- 35 As the term can also refer to the village population as a whole, it thus resembles the term *mangu umangu*, 'possessor of a house', which, as noted, may apply generally to all the inhabitants or specifically to the principal householder.
- 36 There is no (formal) office of village priest, assigned on the basis of clan membership or otherwise, in Rindi; and persons who carry out rites, whether they concern all members of a village or only a single clan, need not belong to the village or clan in question.
- 37 This same principle has been articulated by Cunningham (1967:2) with regard to Atoni society.
- 38 Contrary to Wielenga (1909c:336), clan headmen in Rindi and, as far as I know, elsewhere in eastern Sumba are not called *kabihu* (the word for 'clan').
- 39 This is reminiscent of the situation described by van Dijk (1939a:509) for Laura in western Sumba. In Laura, he says, the clan headman should also occupy and care for the senior house; but because this sometimes proves difficult, as the 'service of the *marapu*' does not fit in with his duties as (secular) leader of the clan, he might then assign one of his slaves to look after the building. The slave thereby comes to be called *rato*, a term cognate with *ratu*, which in Lauru means simply 'person of importance'.

CHAPTER XII

- 1 It is certainly not so regular a practice as it appears to be among some Atoni (see Cunningham 1967:5-6). Thus to characterize eastern Sumbanese society as one that permits '... heterogeneous filiation, where homogeneous filiation (by unilineal principle) operates generally but certain exceptions are allowed' (Firth 1963:27), while not incorrect (since this is a question of degree), could be somewhat misleading.
- 2 The various reasons for migration and the founding of lineages in different domains mentioned in Rindi and elsewhere included permanent settlement subsequent to uxorilocal marriage, internal disputes leading to lineage fission, civil strife between clans, warfare between domains or with foreigners, and persecution by local rulers. There were also two cases where, contrary to the usual pattern, a wife-giving group had moved to the domain and village of its wife-takers.
- 3 I recorded just two cases where this rule had not been observed that involved Rindi clans. One concerned two lines of the clan Wiki which share no known genealogical connexion; and it was evidently for this reason that the marriage, though clearly irregular, had come to be accepted. In the other case, a nobleman of Ana Mburungu in Rindi had married a woman from a lineage of this clan established in Kanatangu. That the woman was childless was attributed to this breach of clan exogamy.

- 4 An expression the Rindi employ to stress the fact that a number of parties make up a single descent group is *hapajii-a-kama*. *Ha-* is 'one'; *a* 'just, etc.', is an emphatic; and *kama* is a form of the exclusive first person plural. The only way I can make sense of this phrase is to regard *pajii* as a nominal form of *jii* 'to plait'. The expression might therefore be translated as 'we are (of) one plaiting'.
- 5 Since the exact genealogical link between Ana Nggela and Ana Mburungu is no longer known (or, at any rate, no longer officially recognized), it is not clear when the split occurred. At one time, though, Ana Nggela occupied the original Uma Andungu, 'Skull Post House', of Ana Mburungu in Parai Yawangu, and it is apparently for this reason that the house, which is no longer standing, is still sometimes referred to as Uma Ana Nggela. Interestingly, the currently recognized *marapu* ancestor of this group is Umbu Pala — Umbu Lapu, the figure especially connected with the Uma Andungu (see Chapter V, Section 4) — the Ana Mburungu *marapu*, Umbu Lutungu, no longer being considered the ancestor of Ana Nggela.
- 6 In other cases where an eastern Sumbanese clan name is the same as that of a place, however, according to local traditions it is the latter which was derived from the former. Examples of this are Rindi, Tabundungu, Tidahu, and Kadumbulu, all of which are also the names of traditional domains.
- 7 The Rindi local clan called Tarimbangu (after its domain of origin) recognizes the same ancestor as the clan Ana Mburungu Kalindingu. The two groups, I was told, were once one but separated following a dispute. They are now independent of one another and any former genealogical connexion between them is no longer known. Ana Mburungu was said to have been the clan's original name.
- 8 Since in many cases migration has disrupted these arrangements, not all the clans whose names compose a quartet in Rindi are actually resident there. Where this is so, then, the method of naming expresses a former residential association. Sometimes, however, a clan name appears in different combinations in different domains, thus reflecting shifting territorial alignments of clan segments.
- 9 Mburu Pala is no longer extant in Rindi, and Kahiku people seem never to have resided there. The connexion between the latter clan and Ana Mburungu, however, is still expressed in the practice of designating slave members of Ana Mburungu in formal speech as Kahiku — Ana Mburungu. (The nobles, of course, are designated with the names of their four *tulaku paraingu* clans; see Chapter XI.)
- 10 The clans are named in formal speech as Lamuru — Luku Walu, Tidahu — Maleri. In this case the one pair apparently bears no known relation to the other, but this is not unusual. Often, therefore, this mode of naming clans seems to have no other significance than to effect a quadripartition.
- 11 The derivative *pakalokangu* means 'to divide', 'to order, arrange', and 'to explain, outline, define, analyze, elucidate'.
- 12 Since, as I mentioned in the last chapter, the genealogical connexion between the commoner lineage Uma Kambata and the noble lineages of Ana Mburungu is not known, this group is left out of account here. Until about thirty years ago, Uma Kambata acted corporately with the nobles, but owing to a serious rift concerning a marriage (which resulted in the relocation of Uma Kambata's principal house and graves from Parai Yawangu to the hamlet of Järiku) in most respects the group now handles its affairs independently of them.

- 13 As shown in Fig. 3 (Chapter II), there were formerly several other named buildings of Ana Mburungu in Parai Yawangu; but these were purely residential houses belonging to the named lineages mentioned above and their names did not denote separate lineal groups. Included among these were three houses — Uma Tobungu, Uma Kandali, and Uma Katangu Kadu — named after special tasks involved in war ritual that were assigned to slaves who once inhabited these buildings. Though they have surviving descendants, due to the disappearance of war ritual these groups are no longer formally extant. Named houses (buildings), therefore, do not always imply systematic lineal segmentation, though where they exist they clearly provide a potential basis for it.
- 14 The (now obsolete) ritual function associated with Uma Andungu apparently contradicts this pattern, since the group that now bears this name is in fact the most junior of the Ana Mburungu lineages. Originally, however, the house called Uma Andungu was assigned to a younger full brother of the Uma Jangga ancestor, who died without heirs.
- 15 It is worth pointing out here that, whereas among the Ana Mburungu nobility Uma Bokulu refers simply to a building — the clan's common ancestral house — in this case the name denotes a particular lineal segment of Mahora as well as the clan's oldest house. (As noted, *uma bokulu* is also a generic term for the ancestral house of a clan.)
- 16 Although the principal house of Uma Pada Njara is located in the same village at that of Uma Bokulu, the name of this lineage thus suggests the association of the younger with the outside and the elder with the inside illustrated previously.
- 17 It can also happen that an elderly couple, perhaps with their younger children, will go to live more or less permanently in another house or a subsidiary hamlet, thus leaving the older house to married offspring. In this case, however, the older people still retain a place within the older house, and authority over the younger inhabitants.
- 18 In Rindi I was told that the clan's ancestral relics are divided subsequent to fission only when a segment removes to another domain, though it can happen, as in one case I encountered, that a segment within the domain that has broken off relations with the main body of the clan will inaugurate relics of its own.
- 19 In this respect, however, Leach's definition of such groups is remarkably vague: he simply refers to persons 'resident in one place' (1961:56) without specifying what is to be understood by 'place'.
- 20 This is shown, for example, by the fact that, whereas the wet rice lands held by Uma Jangga are always spoken of as belonging to the nobility of that group, those worked (independently) by Uma Kudu and Uma Andungu were said properly speaking to belong to Uma Penji. Differences in the extent to which these groups provide one another with (slave) labour also corresponds with this. Thus the slaves of Uma Kudu and Uma Andungu, while directly subject to the noble members of these lineages, were sometimes alternatively referred to as slaves of Uma Penji.
- 21 An arguable exception is certain exchange goods classified as *tanggu marapu*, 'ancestral possessions' (see Chapter V, and concerning their use in marriage, Chapter XVIII). But what I have said just above regarding the 'ancestral field' (*lata marapu*) applies to these goods as well; thus in the case of Ana Mburungu, such wealth is usually spoken of as the property of Uma Penji.
- 22 Similarly, when a couple elope a representative of the woman's group

- must formally approach the headman of the suitor's clan to initiate a reconciliation, even when the identity of the suitor is known or suspected in advance.
- 23 This situation was well illustrated by a marriage I observed between a noblewoman of the lineage Uma Jangga of Ana Mburungu and a nobleman of the lineage Uma Karimbua of the clan Palai Malamba, from Umalulu. Though other lineages of Ana Mburungu are wife-takers of Palai Malamba (the groom's full sister is married to a man of Ana Mburungu Uma Wara, while one of his classificatory sisters [FFFFWSSSD] is married to a man of Ana Mburungu Uma Kudu) all of them contributed to the counter-prestation and received a portion of the (junior) bridewealth. It is worth noting also that Uma Jangga, too, was once a wife-taker of Palai Malamba, but of a lineage of that clan other than Uma Karimbua.
- 24 I refer here to the process noted by Wilder (1964:1369, citing Needham 1958:87 and Leach 1961:44-45) whereby new alliance groups are formed through segmentation subsequent to marriages that are deviant in terms of existing alliance patterns (see also Needham 1960b:499, 501; 1964b:1382).
- 25 In more than one instance named lineages of Ana Mburungu maintain identical alliance connexions with the same affinal clans and do not take (or have not yet taken) wives from groups to which others have given women. Similarly, I found only five marriages contracted by one or the other of the two lineages of Mahora which clearly constitute direct exchange at the level of the clan; and this figure is no higher than that which might be expected for Rindi clans of comparable size which are not divided into named lineages (see Chapter XIX).
- 26 I was unable to obtain full clarification of the extent to which the involvement of such groups is affected by any affinal relationship with the principal. However, as was shown with regard to commoners who take slave wives from the nobles, in this case at least, being (in a sense) a wife-taker does not preclude a party from acting like an agnate towards a wife-giver when the latter assumes the role of wife-giver in respect of other groups.
- 27 It should be recalled that the Rindi nobility have no affines within the domain. Thus noble marriages and funerals always involve groups from the outside. At commoner funerals, also, the majority of invited affines usually come from outside the village.

CHAPTER XIII

- 1 *Kalembi* is probably related to *kalambungu*, 'to wrap (a loin-cloth) around the body'. The dialectal equivalent in north coastal Sumba is *kalembu*. Cf. also Indonesian *kelambu*, 'mosquito net'.
- 2 One's own affines can be specified as *kalembi wiki* (*wiki*, 'own'), *kalembi tuba*, 'true affines', or *kalembi totuku*, 'exact, real affines'. Wife-givers or wife-takers of one's own wife-givers or wife-takers respectively are described as *kalembi uku*, which might be glossed as 'legal affines' (*uku* is 'custom, law, norm'). *Kalembi wiki*, 'own affines', is also used to specify the most closely related affinal lines within a wife-giving or wife-taking clan. While according to one opinion, *kalembi* should extend only as far as the affines of affines of one's own affines, thus with ego's group making a series of four groups, others held that there was no predetermined point at which the boundary could be drawn.

- 3 E.g., among the Atoni (Schulte Nordholt 1971:160), in central Timor (van Wouden 1968:14, citing Grijzen 1904), in Wailolong, East Flores (Barnes 1977b:147), and in Manggarai (Needham 1966a:153).
- 4 In Mangili, male and female infants are designated respectively as 'pig's leg' (*witi wai*) and 'dog's leg' (*witi atu*) (Onvlee 1949:452). Apparently, the idea is that the birth of a girl, for example, betokens her parents' standing as a wife-giver, for whom the group of the child's prospective spouse will slaughter a dog.
- 5 *Anakawini* is distinguished from the term for daughter, *ana kawini*, 'female child', by the position of the possessive pronoun, e.g., *anana kawini*, 'his daughter', and *anakawinina*, 'his wife-taker'.
- 6 The Karo of Sumatra, who also practise asymmetric alliance, call the wife-taker *anak beru* (*anak*, 'child'; *beru*, 'woman'), which Singarimbun (1975:113) translates as 'people of the woman', 'the woman's people', 'one's daughter's (or sister's) family'. The idiom is thus virtually identical to *anakawini*. Cf. also Manggarai *anak wina*, 'wife-takers'; *wina* is 'female', '(potential) wife' (Needham 1966a:153).
- 7 These include 'the chicken that does not descend (from its roost), the pig that does not go out (from under the house)' (*manu mandapuru, wei mandaluhu*); 'dusky black pig that knows the space beneath the house, bright red chicken that recognizes its house' (*wei miti kumbuhu na matanda mbo-mangu, manu rara wakihu na matanda uma*); 'chicken's wing, pig's armpit' (*kapa manu, halili wei*); and 'plump piglet, fat chick' (*ana wei kawondi, ana manu ramu*). The first two pairs of phrases express the theme of remaining in the house (i.e., the alliance) and so especially refer to long standing wife-takers.
- 8 Wife-givers of long standing are called 'father and mother since long ago' (*ama weli memangu, ina weli ndai*).
- 9 Noble wife-takers, however, may be addressed as *umbu ana, rambu homu*, 'lord and lady (my) child', which thus indicates the need to express respect with regard to rank despite the relative inferiority of the party addressed in terms of alliance.
- 10 As an equivalent of *homu* in this context, Kapita (1976a:84) gives *huhu*, 'breast', 'milk', 'to suckle', which, however, he glosses as 'grandchild' (see Indonesian *cucu*); but I never encountered the word used with this meaning in Rindi. The notion of suckling with reference to the alliance relation, though, is further revealed in the phrases 'breast on the left, breast on the right' (*huhu la kalai, huhu la wakana*), which denotes a party that is the wife-giver of two others. The image is of a woman simultaneously suckling two infants.
- 11 Among the Karo of Sumatra, the part of the house occupied by the chief householder is called 'the base of the tree', while the section opposite, occupied by his deputy, one of his wife-takers, is called 'the top of the tree' (Singarimbun 1975:61).
- 12 See the phrase *pingi yera*, 'source of the wife-giver' or 'principal wife-giver', which similarly can refer either to a long established *yera* or to the wife-giver of the wife-giver.
- 13 *Pingi ai*, 'source of wood', is usually to be translated as 'tree' (cf. Indonesian *pohon kayu*, 'wooden trunk'). Similarly, *mata wai*, 'source of water', denotes a spring or the origin of a river. I have already remarked on the association of the Head of the Earth (*katiku tana, katiku mata wai*; see Chapter III), which is the origin of the major rivers, with wife-giving affines.
- 14 For a discussion of the various uses of *mata* in the Austronesian languages see Barnes 1977a:300-319.

- 15 With reference to a tree, *pingi* and *pola* are distinguished respectively as the lower part of the trunk and the entire length of the stem. A hewn trunk is called *pola* not *pingi*, though as noted the latter word can refer to the entire (living) tree. The terms are combined in another Rindi expression that refers to wife-givers: *pingi pola ndara, mata wai kalada*. *Kalada*, 'tongue', also denotes the source of a river. I am not sure of the meaning of *ndara* here.
- 16 Kapita (1976a:111) similarly glosses the term as 'place of origin' (Indonesian, *tempat asal*).
- 17 *Wai karanu*, 'scented water', apparently refers to the water with which a new-born infant is bathed. I am not sure of the significance of 'roasting coconut' (*tunu kokuru*); but it occurs to me that this might be a corruption of *tungu kokuru*, 'to use, apply coconut'. The exact import of the other two phrases is also unclear. *Pinu marada*, 'surface of the plain', though, also denotes the top of the head and the fontanelle. By virtue of the phrases being conjoined, it seems that this part of the head may here be conceived as analogous to the pole that runs along the ridge of the roof (*toku ndidu*). 'Ridge pole' thus suggests something which closes off and lends protection, possibly in this case to the fontanelle.
- 18 Similarly, in Wailolong, East Flores, the prescribed category of women is called *mure wana*, 'a term which translates as the admonishment "to take from the right"' (Barnes 1977b:146).
- 19 Here it is worth noting Singarimbun's remark that matrilineal marriage among the Karo is regarded as 'a good thing in and of itself', since it 'conforms to the natural order of things' (1975:156).
- 20 That the complementary term *mata* is also appropriate to descent is shown by the phrases *kamata bai, kamata mini*, 'male and female forbears'. As a variant of *mata*, the word *kamata*, with regard to root crops, refers to that part of the mature root that is cut off and replanted. That it has the further senses of 'knot, joint' (Kapita 1974) is reminiscent of the use of *kawongu*, 'knot, joint', to refer to a generation or genealogical level (see Chapter XIV).
- 21 Cf. the Atoni terms 'life-giving, life-generating affine' (*bab honit*) and 'life-generating father, procreator' (*ahonit*) as references to the own father and MB/WF respectively (Schulte Nordholt 1971:107).
- 22 See the Mamboru (western Sumba) term *angu wua* (B, FBS, MZS), which Onvlee (1938:1) glosses as 'fruit from the same stem'.
- 23 Similar constructions are found in western Sumbanese societies, some of which do not practise asymmetric prescriptive alliance, e.g., Kodinese *dungo kambo*, 'to share the same womb', which denotes B, FBS, MZS (m.s.). The Toba Batak term for clan mate, *dongan saboetoeha* similarly means 'who have come from one belly' (van Ossenbruggen 1935:9).
- 24 In other parts of Indonesia, by contrast, similar tasks, in particular hair cutting, are assigned to wife-givers (see Fox 1971b:237; Barnes 1974:155). That wife-takers and slaves are seen to be similar is further shown by the fact that, while the Rindi are careful to distinguish the two designations, the phrases *anakeda la kuru uma* and *ana la kuru uma*, 'children within the house', which refer to slaves and wife-takers respectively, are virtually identical. In both cases, moreover, the idea of having a place within the house implies being protected and sheltered, as well as subordination.
- 25 Another expression applied to wife-takers in Rindi is 'those who hold the vessel and fathom the lance' (*matema kaba, marapa nambu*). The phrases, which refer to the acts of invocation and augury, were explained as an allusion to the practice of having a wife-taker officiate at certain major

- clan rites, such as the first fruits (*ngangu uhu*) ceremony. But although this agrees with Kapita's (1976a:84) interpretation of another version of the phrases, I obtained no further information on this point and am therefore unable to say what the exact significance of the custom might be. It is certainly not generally required that a wife-taker perform rites addressed to the wife-giver's clan ancestor.
- 26 These practices are comparable to customs found elsewhere in eastern Indonesia, where a ZS must pay a fine to his MB in the event of injury (e.g., on Roti, Fox 1971b:238), or death when the MB has not previously been informed of serious illness (e.g., in Kédang, Barnes 1974:249).
 - 27 The curse of the mother's brother, however, does appear in mythology. In at least two clan myths it is mentioned how an ancestor came to grief after incurring the displeasure of his maternal uncle.
 - 28 With reference to the extensive influence of the ruler of Lewa during the nineteenth century, Kapita notes that he '... had marriage connexions with all the rulers and nobility from Nàpu to Wai Jilu ...' (1976b:33).
 - 29 In a more general and informal sense, wife-givers, too, can derive prestige from an alliance. Here I am thinking particularly of when a nobleman marries a commoner woman (from another domain), in which case there is in my experience a tendency on the part of people in general to presume that the wife-giver as well is of noble rank.
 - 30 In this respect, the situation in Rindi seems generally similar to that which obtains in Kédang, where according to Barnes (1974:247) '... assistance [between affines] is not necessarily one sided, but the primary obligation lies with the wife-taker'.
 - 31 In order to avoid giving offence, when speaking to a wife-giver one should use in place of *tilu*, 'three', circumlocutions such as *dàmbu hau*, 'two (plus) one', since *tilu* also has the meaning of 'testicle'. Particularly to be avoided is the expression *tilu mbua* (*mbua*, a variant of *wua*, is a class word), as this can be taken to mean 'swollen testicle'. In fact, for this reason *tilu* is generally avoided in polite speech, though with non-affines it is usually sufficient to replace it with the variant *tailu*.
 - 32 Onvlee (1973:223), referring to eastern Sumba generally, lists several other restrictions a daughter-in-law should observe; but so far as I could discover these are not required in Rindi. Since they mostly refer to possessions of the father-in-law's (and hence the husband's) clan, moreover, I am not sure that the rules might not apply specifically to a woman for whom bride-wealth has yet to be completed.
 - 33 Since *meti* is 'to die', and *meti widi* refers to the trance into which the attendants of a noble corpse are expected to fall, this rather curious idea recalls the notion that after death the HZH and WBW become marriage partners.
 - 34 The reciprocal prohibition of consuming left-over food and drink is also one of several restrictions that apply to clans which, because of an ancient dispute, are bound by oath (*pahara hakingu*) to forgo all formal intercourse: they may not give or take wives from one another, enter one another's ancestral houses, or climb fruit-bearing trees belonging to the other. Avoidance is insisted upon to the extent that if a man of one clan commits adultery with the wife of a man of the other, it is not possible to exact a fine; and even if male and female members of clans related in this way should begin to cohabit, as in one case I encountered in Rindi, no bridewealth can be given or received.

CHAPTER XIV

- 1 A fairly complete vocabulary of the relationship terms in the Kambera dialect is also found in the word lists compiled by Pos (1901) and Wielenga (1909a, 1917); but as the authors give only one or two genealogical glosses for each term, these data are of little use for analysis. Eastern Sumbanese relationship terms are also included among the earlier word lists by Heijmering (1846), Anon. (1855), Roos (1872), and de Roo (1891).
- 2 In Kambera and a large part of eastern Sumba, where *mamu* is applied to both FZ and FZH, the latter is specified as *mamu mini*, 'male *mamu*'. It is evident, therefore, that in these districts *mamu* is primarily understood as a female category, while *tuya* and *yera*, in Rindi and elsewhere, are understood as male categories.
- 3 Another word for descendant (traced through either men or women) is *wāla*, 'flower'. In western Sumba the same term denotes the matriline, and in Kodi a matrilineal descent group.
- 4 *Bokulu*, 'big, major', is not used as a synonym of *maaya* to refer to parents' elder siblings. With regard to *ama*, 'father', *ama bokulu* is precluded as a reference to FeB by virtue of its use in the senses of 'elder', 'headman', and 'priest'.
- 5 One of the phrases used to refer to an unmarried person, or a widow or widower, in parallel speech is thus *kaheli hakapapa*, 'house floor with (only) one side'. As noted, the floor of a building is conceptually divided into two halves, one of which is symbolically male and the other female (see Chapter I).
- 6 In Kambera (see Fischer 1957:3), *angu* is further encountered in the term *angu leba*, 'fellow sister's child' (*leba* is a form of *laleba*, ZC), a reciprocal term used by sister's children; *angu riina*, 'fellow wife', which refers to HBW; and *angu riina ina*, 'fellow wife of mother', FBW. None of these usages is employed in Rindi, however.
- 7 Kapita (1976a) employs *biliku*, 'compartment', for 'conjugal family' (Indonesian *keluarga batih*); but in Rindi I encountered the word only in this particular expression, and I never heard it used alone as a reference to a familial group.
- 8 Concerning the use of 'plant metaphors' to represent the relation of MB and ZC on Roti, see Fox 1971b.
- 9 This same equation is found among the Toba Batak and in Ende (Needham 1966b:173, citing Fischer and van Renselaar 1959:53-4 and van Suchtelen 1921:104-05). In Rindi, the expression *paanamini-paanawiningu*, 'to be related as (or like) brother and sister', is employed generally to refer to a relation or situation in which sex or marriage is prohibited.
- 10 As the reference term for BC (w.s.), Onvlee lists only the descriptive phrases *ana ana mini*, 'brother's child'; but in Rindi this relative is always called *dawa*.
- 11 A genealogical level (or generation) is usually expressed in Rindi as (*ha*)*ndalihu*, which otherwise refers to the space between the joints of the body, and the points of branching on the stem of a plant or tree. Different levels are thus specified with reference to the terms from ego's line as *ndalihu umbu*, 'grandfather's generation', *ndalihu ama*, 'father's generation', and so on. In ritual speech, the notion is further reproduced with the words *handàdiku*, 'one level', *handàlaru*, 'one row', *hawawangu*, 'one descent', *haràjingu*, 'one crop' (of a tree before picking; *ràjingu* means 'packed with fruit'), and *hakawongu*. *Kawongu* is 'joint' or 'node' (of bamboo or a maize

- stalk, etc.). Thus the Rindi express the idea of a genealogical level with reference to both joints and spaces between joints.
- 12 Whenever I consider the number of terms that reflect particular principles I omit those which refer specifically to spouses (i.e., *lei* and *papaha*).
 - 13 Persons in the category *umbu*, for example, can be distinguished as *umbuyera* and *umbulayia*, 'wife-giving' and 'wife-taking *umbu*', but these are purely descriptive devices and not standard specifications.
 - 14 The relation of a married woman and her parents is described as *pakalembingu*, 'related as affines'.
 - 15 It seems relevant, then, that the woman's term for brother, *anamini*, 'male child, person', corresponds exactly to *anakawini*, 'female child, person', the term for wife-takers. Among the Atoni, the cognate terms *an mone* and *an fetu*, which Cunningham (1965:373-4) glosses as 'male child' and 'female child', denote wife-givers and wife-takers respectively.
 - 16 *Rii* can also mean 'vegetable, plant' and 'spine, rib (of a leaf)'.
 - 17 Though a female informant once gave *ana* in addition to *dawa* as a possible term of reference for MBSDH, since none of the other specifications in this category (BS, FBSS, MZSS, MBDS, BWZS, etc.) were given as *ana*, there is reason to suspect that this is neither a correct nor usual term for this relative.
 - 18 A woman's subordination to her HZ is sometimes referred to the idea that the bridewealth received at the marriage of the latter is the means by which her own marriage has been made possible.
 - 19 The Rindi sometimes address an unrelated person whose relative age is not known with the reference terms for siblings.
 - 20 In many parts of eastern Sumba where *umbu* is also used as a general honorific, however, men in this generation are called by a special term, *boku*.
 - 21 Interestingly, Onvlee (1938:6) says that *dawa* is extensively used in Lauili (western Sumba) to address FBC of about the same age or younger, and that it is a friendly way of addressing servants.
 - 22 Spouses and closely related persons otherwise called *aya* or *eri* may also be addressed by proper name alone. With regard to the latter, however, this is considered rather familiar, and the preferred form is to place *aya* or *eri* before the name.
 - 23 The use of *umbu* and *rambu* to address spouses varies significantly according to the speaker's class. Thus, while these terms are standard among higher ranks, especially the nobility, slave couples nearly always address one another by name.
 - 24 Younger informants described this as an antiquated usage no longer employed in ordinary speech, except by the very old. I am not sure, though, that it is a dying idiom; for it seems just as likely to be a form of address sometimes adopted by a person when he becomes elderly.
 - 25 Umbu Kudu ('Little Lord') is also encountered as a nickname of (especially) younger sons of the nobility. The only son of the late government raja of Rindi, who is now a teenager, is always referred to, by all Rindi, as Umbu Kudu.
 - 26 Dempwolff (1938:50, 120) compares **ə(m)pu* to *pu*, 'lord', which as mentioned has been suggested as the root of Sumbanese *marapu*. As Barnes (1979:20) has recently noted, reflexes of **ə(m)pu*, have a variety of distinct applications in different Indonesian languages.
 - 27 For western Sumba see *ambu* (Kodi), PP, CC; and *ubu* (Lauli), PF, CC. Other languages of the Bima-Sumba group include *empo* (Manggarai) and

apu (Savunese), 'grandparent', 'grandchild'; and *ompu* (Bimanese), 'grandfather', 'grandson'. See also *ambu* (Endenese), PP, CC. The Rotinese and Atoni cognates of *umbu* (viz., *upuk* and *upu*), by contrast, apply only to grandchildren.

- 28 In a Kampera narrative recorded by Wielenga (1913:217), an ancestor, who is otherwise identifiably male, is addressed as *àpu*, which the author thus glosses as 'grandfather'. From my own records, it is worth noting the phrases *tana àpu*, 'land of the ancestors, native country' and *àpu wuya*, a reference to the crocodile. In the latter instance, the designation was said to apply only to the female of the species; but since this relates to the imaginary idea that only the females ever appear in ordinary guise, the specification could well be a secondary elaboration.
- 29 A number of alternative forms should be noted. Deceased grandchildren as well as children are addressed, in a rather suppliant manner, as *ananggu*, 'my child'. Persons in ego's generation may be called *tamu umbu* and *tamu ràmbu*, which otherwise are applied only to (living) high ranking noblemen and noblewomen. (I am not sure whether other generations might not also be addressed in this way.) A husband may alternatively be called *miri*, 'lord', 'master'.
- 30 I should point out that this interpretation assumes that *umbu* as applied to a dead person in ego's or descending levels, where it is complementary to *ràmbu* (and not *àpu*, as in the case of the grandparental generation), is used as a general honorific and thus does not have the specific sense of 'grandfather' or 'forebear'.
- 31 It also seems relevant in this connexion that whereas parents have temporal authority over ego, both wife-givers and members of the second ascending genealogical level exercise mainly a spiritual influence. In this regard, then, members of this generation cannot be distinguished in the same way as, for example, can ego's F and MB in the first ascending level.
- 32 With regard to alliance, the exceptions are *dawa* and *anawini* (Z, FZD, etc.). Since the latter term comprises all women in ego's level actually or prospectively belonging to wife-taking groups, however, *anawini* could arguably be counted as another alliance category.

CHAPTER XV

- 1 *Lalei*, from *lei*, 'husband', can be glossed as 'to be, become a husband'. In ritual speech, *lii lalei*, *lii mangoma* is sometimes conjoined with *lii teki*, *lii paha*. As noted, *teki* is a dialectal form of *piti*, 'to take', in this case a woman in marriage, while *paha*, the root of *papaha*, 'wife', is 'to join, pair, match'. *Mangoma* is possibly a contraction of *mangu uma*, 'householder, occupant of a house'; cf. *lumbu uma* and *mboma(ngu)*, both of which denote the space beneath a building.
- 2 Although it is the man who is said to 'look after' (*kanoma*) the woman, the word also appears in the reciprocal form *pakanoma*, 'to look after one another'.
- 3 In this regard, the Rindi show concern that initiating a new alliance should not infringe upon the rights of an established wife-taker of the wife's lineage. To do so is expressed as 'to pelt other people's chickens and pigs' (*tuku manu tau*, *wei tau*), which, in accordance with the femininity of these animals, seems to refer to another clan's wife-takers.
- 4 Curiously, *hili* usually means 'again'; so the first phrase, for example, could

- apparently also be translated as 'a path cleared again'. I was assured, however, that this refers to marriage with a previously unrelated group.
- 5 Since *tuya* also applies to MBWB, stated in this way the rule could logically be taken to include MBWBD as well. But as this woman is classified as *yera kawini*, it is evident that this is not intended.
 - 6 I never heard of a compensatory payment to be made to a woman should a prospective husband marry her younger sister while she is still unmarried, which Kruyt (1922:501) reports for some parts of Sumba.
 - 7 The practice is called *beri hàda*, *hira tera*, 'to divide the beads, to tear the cloth(s)', referring to the counter-prestation goods that accompany the women in marriage.
 - 8 Kruyt's (1922:494) ambiguous remark that two brothers can marry two sisters 'provided they are from a different kabisoe [clan]' might be taken to indicate that this arrangement is prohibited or disapproved of in some parts of Sumba. Indeed, an Umalulu man once told me that two brothers should not marry two sisters; but, as he admitted, such marriages occur as regularly there as they do in Rindi.
 - 9 This arrangement may be compared with the institution of *beibei*, 'which follows', among the Ema of Central Timor, where a wife is taken from the wife-giver of a wife-giver either when the marriage would not normally be permitted or if no other relation between the prospective spouses would prevent it (Clamagirand 1975:83-4).
 - 10 The expression refers to the leaf icons suspended around fruit bearing trees as a mark of ownership. Though the rights of the prospective husband's group are no longer recognized by the Indonesian authorities, the practice of infant betrothal still continues.
 - 11 A lover is called *yora*; *ngia pambawa*, 'a place (party) where (with whom) one spends free time'; or *angu eti*, 'companion of the liver (heart)'. Another expression is *kuta*, 'betel', which refers to the lovers' practice of offering one another betel and areca (*pakutangu*).
 - 12 I never heard that it was improper to court a girl who is a preferred or prescribed spouse, as Singarimbun (1975:166) reports of the Karo.
 - 13 The more polite term for an illegitimate child is *ana mbawa*; *mbawa* is 'to have free time, go for a stroll'.
 - 14 One or more of the wives of 24 of the 307 polygynous men were specified as inherited widows. Since there may well have been more than these, however, the figure should not be taken as an accurate reflexion of the incidence of widow-inheritance.
 - 15 To avoid distortion, from the total of 307 I have excluded 16 cases where men of the slave class were married to two or more women of their own clan (see Section 7 below).
 - 16 In Kédang, where this is the most suitable and frequent form of plural marriage, 20 per cent of cases involved sisters (Barnes 1974:257).
 - 17 Such a young wife is called, somewhat jocularly, her husband's 'betel pounder' (*tanggu tuku*), the implication being that at this age he will lack teeth and so must have his betel and areca pounded into a soft mush for him. Since in these circumstances a sexual relationship is usually not contemplated, rather less attention is paid to the woman's class standing than would otherwise be the case.
 - 18 I give the figures for both first and second wives because I suspect the genealogies might not always accurately reflect the actual marriage order of the women.
 - 19 Thus in the case of the Rindi noble clan (see Chapter XII and Fig. 7),

- for example, widows of Uma Penji men can be inherited by men of Uma Andungu and Uma Kudu, but not by men of the other, lower ranking lineages of the clan.
- 20 My informants did not specify how distantly related the person need be. Clearly, though, a SS or HFF would not be appropriate.
 - 21 Indeed, the Rindi often speak of the wife of a living brother or other agnatic generation mate as 'our wife'. But this does not of course imply that the speaker has the same rights in the woman as does her husband, e.g., to her sexuality.
 - 22 Cfr. Kruyt (1922:509), who says adultery on Sumba appears not to lead to separation (or 'divorce', Dutch *scheiding*, which has both senses).
 - 23 This is not an increment of bridewealth but an additional transaction.
 - 24 Wielenga (1926b:271) states that a marriage is difficult to dissolve in eastern Sumba and that among the higher classes it is practically impossible.
 - 25 A man calls his legal child whose genitor was another man *nganggu anangu*; *anangu* is *ana*, 'child', while Kapita (1974) lists *nganggu* as 'adornment, decoration'. The genitor of another man's legal child, on the other hand, calls the latter *ana wai laru*, 'rainwater child', a phrase which possibly involves a symbolic equation of rain and semen.
 - 26 In this way, the last government raja of Rindi paid the bridewealth for the wife of his FBS, so that this man's son might succeed him. (Shortly after the raja's death, however, the system of hereditary administration was abolished.) Van der Heijden (1923), in an appended genealogy, notes that the childless raja of Mbata Kapidu secured the succession of his FBSS by the same means.
 - 27 Cunningham (1964:21-37) describes a similar, though apparently more common and developed, institution among the Atoni of Timor.
 - 28 *Ana radangu* can also refer to orphans and the children of inherited widows. The reciprocal term *ama radangu*, 'foster father' (cf. *ina radangu*, 'foster mother'), is thus sometimes also used to specify a 'stepfather', i.e., a man who inherits a widow, by the dead husband's own children. Usually, however, such persons are simply referred to as *ama* ('father') and *ana* ('child').
 - 29 Kapita (1976a:118) says a woman may 'adopt' (Indonesian *angkat*) a brother's son as her (presumably her husband's) heir; but while there was one case in Rindi where a man had inherited property from his childless FZH, the last man of his lineage, this entailed no change of clan membership.
 - 30 This usually concerns not an entire clan but only the highest ranking line, the *maràmba bokulu*.
 - 31 Or 'to kindle a fire that has gone out, to bring forth dried up water' (*padukulu epi mambàda, pakalubuku wai mamihì*).
 - 32 Long ago, the Umalulu clan Palai Malamba was thus revived by the clan Matalu, and, more recently, the Kapunduku nobility, Ana Macua, by their wife-takers, Ana Maeri in Kanatangu.
 - 33 That an arrangement of this sort constitutes the purchase of a husband, as Kruyt (1922:507) claims, was emphatically denied in Rindi.
 - 34 That slaves in the past sometimes contributed to the bridewealth given for their wives is also indicated by de Roo (1890:585), who states that a slave wishing to take a wife had often to make a 'marriage gift' to his master.

CHAPTER XVI

- 1 In contrast to incest and adultery, though, an affair with an unmarried woman that is not incestuous does not seem to involve, at present at any rate, any standard compensatory procedure or fine. Even so, it may lead to a dispute, especially when the woman is shortly destined to be married to some particular individual, in which case her family can require the man to declare formally that he will dissolve the relationship. In one instance I came across, the culprit was required to provide a fowl and rice for a common meal, at which this was done. Nowadays, officials of the *desa* government (see Introduction) are responsible for seeing that such matters are resolved, and commonly the man receives a beating at their hands.
- 2 In his dictionary, Kapita (1974) gives as one gloss of the word the possibly cognate Indonesian term *curang*, 'dishonest, deceitful, fraudulent'; but while young Indonesian speaking Rindi sometimes used *curang* to denote sexual transgression, so far as I know *njuraku* is only ever used to refer to incest and adultery. Other words employed for these offences, however, are indeed more generally applied to wrong-doing. The commonest is *ndànga*, 'wrong, false', 'to err', 'to deviate', etc., although in the form *ndànga dangu*, 'to do something wrong with (someone)', this too seems invariably to refer to sexual transgression. In parallel speech, *ndànga* is paired with *ndoku*, 'mistake, error, fault', 'improper, in vain'; and both words are further used with the sense of 'to confess, acknowledge a transgression' and '(to make a) compensatory payment'.
- 3 I was unable to obtain full clarification of what should be done in the case of adultery with a FBW (who was not simultaneously MZ) or a SW. Since an affair with a daughter-in-law was claimed by some to be as serious as with a daughter, however, possibly they would treat it as incest.
- 4 In ritual speech the adulterer is thus described as 'the one who digs my (i.e., the offended husband's) grave, who carves my tombstone' (*na maàkingga lambongu metinggu, na makahebingga watu pudanggu*). To protect himself, the husband can have a rite performed to deflect the implied injury to his person so as to result in death or misfortune for the adulterer. This procedure is called 'to make firm the *ndewa*' (*pamandungu ndewa*).
- 5 The idea that a husband's soul (*hamangu*) is threatened by his wife's adultery should also be referred to the evaluation of the offence as a severe insult manifesting a gross underestimation of the cuckold's worth and integrity. It is thus considered a disturbing experience of the sort likely to cause the soul to become estranged from the body (see Chapter IV). The Rindi say of an adulterer that 'he has considered (the cuckold) as someone easy and familiar, someone small and trifling' (*ilumananya pamuda pamareni, pamimu pamàrahu*), and that 'he has treated him like a low (i.e., easily crossed) stone wall, a cactus hedge with graps' (*ilumananya pakilimbatu makaràda, kalàla makanjenga*).
- 6 The practice seems to be rare elsewhere in Indonesia. Van Ossenbruggen (1930:217), referring to the published sources cited above, says he found it mentioned only for the Sumbanese.
- 7 While such ideas are common elsewhere in Indonesia, Kruyt (1922:495), also, says he never encountered them on Sumba.
- 8 Cfr. Kruyt (1922:495), who says that in eastern Sumba incestuous persons were killed only in the Tabundungu district.
- 9 Though I have in fact seen it carried out in the case of transgression

- involving HZH and WBW, a reliable informant claimed it was not actually necessary to do so in this instance.
- 10 The phrases are somewhat reminiscent of a Kédang expression for incest, *ula-lojo* (literally 'moon-sun', the name of divinity), which in this context can mean 'feet to the sky'. According to Barnes (1974:261, 109), this involves the idea that incest is like confusing the sky and the earth. Hence '... the sky must be ceremonially brought down so that it may then go back up and effect the division which is necessary to return everything to order' (ibid:261).
 - 11 As noted, *mata lodu*, 'sun', is also a euphemism for the male genitalia. The idea that this exchange represents a limit which must not again be transgressed is further expressed with the phrases 'let not the fire be stepped over, let not the goods set down be trodden upon' (*ambu pangga mata epi, àmbu liti lii pabànjalú*). The first phrase, I was told, refers to the fire on which the hair of the pig subsequently slaughtered is burnt off prior to butchering.
 - 12 By another account, only the pig provided by the wife-taker may not be eaten. Perhaps, though, the rule is that the animal given by the opposite party may not be eaten by the man and woman respectively. Barnes (1974:261) notes that in Kédang the animal killed at the incest ceremony is forbidden to all members of the clan in question (he refers here to incest within the clan).
 - 13 One set of phrases uttered by the functionary of the *wai maringu mbana* at this point is 'let me tie up captives for you and split a village for you' (*màta ka ku-likunggau tanawangu, beranggau paraingu*). As this is a standard expression for war, it seems to mean that the *wai maringu mbana* is waging a battle (against either the incest, or the incestuous couple, or perhaps both) on behalf of the principal.
 - 14 It is not entirely clear to me what happens when the rite is performed for just one of the two individuals involved. Although it seems more appropriate that the other would be called to participate in this, my informants thought that the opposite part would be taken by the principal's spouse.
 - 15 By contrast, Kruyt (1922:495), describing a similar rite from Kambera, says the dog is killed and the carcass is divided in two, one half being hung to the east and the other to the west. Comparison with other rites at which a dog is slaughtered when something considered hot is to be removed (see, e.g., the *pahili mbola* ceremony, Chapter IX, Section 6) suggests this may once have been the practice in Rindi as well.
 - 16 In the Mangili incest ceremony, the entrails of two slaughtered dogs are tied together with pieces of men's and women's clothing and all is then cast out to sea (Kruyt 1922:496).
 - 17 The Rindi often refer to sexual transgression as *njuraku la tana*, 'transgression on (against?) the earth'. While the phrase apparently denotes offences actually committed outside the house, however, I think it is also applied to illicit sex in general.

CHAPTER XVII

- 1 *Wili*, 'price', 'worth', 'value', 'use', can denote what is given in return for a variety of items. The usage, therefore, is evidently an exception to van Ossenbruggen's (1930:221) generalization that the word used in most

- Indonesian societies to denote the payment given for a wife has the specific sense of 'bridewealth' (Dutch *bruidschat*).
- 2 Among the nobility, the knife provided by the wife-giver is typically a particularly valuable sort: one with an undulating blade (*ledingu*) and an ivory handle, placed in a sheath ornamented with silver. It is carried only on the most formal of occasions.
 - 3 In the Dutch literature, *mamuli* is usually glossed as 'ear pendant'. By contrast to the practice in the western part of the island, however, they are not worn on the ears in eastern Sumba. Unfortunately, I do not have any good photographs of these objects or the metal chains. The interested reader might therefore refer to Kapita (1976a:127).
 - 4 Bridewealth portions are designated as 'betel' and 'areca' also among the Atoni (Schulte Nordholt 1971:115) and the Ema (Clamagirand 1975:86) of Timor.
 - 5 Beads and armbands originally derive from trade, the latter in the form of elephant tusks that have since been fashioned into bracelets (by men). They are worn as decoration by both sexes. Beads are now given in strings and armbands in pairs, though formerly, I was told, loose beads were also given in containers (see de Roo 1890:574). I was also told that elephants' tusks, which are now rare in eastern Sumba, were occasionally used in the past as counter-prestation in Rindi. In other parts of Indonesia they are often used as bridewealth. I once encountered the phrases 'the broad cloths, the large brass (also 'copper', perhaps an allusion to some sort of bracelet)' (*da kamba da mambàlaru, da kaliyangu da mabokulu*) as a reference to beads and armbands. The first term, then, suggests a symbolic equivalence between these goods and textiles.
 - 6 Hereafter, when quantities are indicated, I shall therefore usually mention the pendants alone. The chains are not actually fastened to the pendants in Rindi, as Onvlee's (1949:453) description might suggest.
 - 7 This occurs, I was told, when the wife-giver requests for each of the two horses (a stallion and a mare) initially proposed, 'its mare' (*na baina*). Since a single horse given should ideally be a stallion, it seems that the two animals are thus each treated as though they were individual prestations and hence male. What is requested, of course, is two pairs of one stallion and one mare. By requesting 'a mare' for each, therefore, the wife-giver implies that the basic prestation is incomplete.
 - 8 These sashes are now rare in eastern Sumba and are seldom any longer used in exchanges between affines.
 - 9 I never heard that the personal qualities of the bride could affect the amount of bridewealth, as Schulte Nordholt (1971:107) states for the Atoni.
 - 10 The only evidence I encountered of money replacing traditional articles as bridewealth in Rindi is the recent practice of giving a coin or a bank note in place of a copper chain, as the complement of a tin pendant. Even in this case, however, the actual monetary value of the coin or note seems not to be a consideration.
 - 11 The Rindi themselves usually specify bridewealth quantities simply in terms of the number of horses they include. This is consistent with the fact that these animals usually constitute the most expensive part of the prestation.
 - 12 At 1975 prices, the commercial value of a horse was mostly between 15,000 and 25,000 rupiahs.
 - 13 Kapita (1976a:61) states that in the past bridewealth consisted only of metal goods — knives, spears, adzes, gongs, and the like — while Kruyt (1922:501) mentions that in Lewa the prestation was formerly spoken of as 'the iron

- and the dog'. 'Iron' in this case referred to a spear or sword always included in the gift.
- 14 Buffalo are not used as bridewealth in Rindi.
 - 15 *Kundu patini* was said to refer to the masculine, and *tularu epi* to the feminine component of the prestation. The two parts, which are separated only conceptually, are also described as the 'father's share' (*tanggu ama*) and the 'mother's share' (*tanggu ina*). Kapita (1976a:133), on the other hand, states that the two phrases together denote only the feminine part of the gift, while the masculine part is called the *hondu talaru, pai witu*, 'tying of the laths, binding of the thatch'. Onvlee (1973:91), who also records this expression, says it refers to the bride's father's labours expended in providing the house in which the woman was born. Since both authors refer to eastern Sumba as a whole, however, it is not clear whether we are dealing here with alternative interpretations of a common idiom or a regional variation in usage.
 - 16 None of the quantities mentioned in this section is meant to be definitive.
 - 17 Kapita (ibid.) also says that the component metal valuables in this case are placed in a small basket, on the rack (*yarangu* or *hindi maringu*, see Chapter I) to the right (as one enters) of the right front door. Though Nooteboom (1940:49) also mentions this custom, no one I asked in Rindi seemed familiar with it; so I presume it is not (or is no longer) practised there.
 - 18 Onvlee (1973:92), who also mentions this gift, says that it is for the bride's mother's brother. So far as I know, when it is provided it is given in addition to the *kuta rara, kaliti pangga*.
 - 19 According to Kapita (1976a:83, 95, 131), it was formerly the practice among the eastern Sumbanese nobility to give, in addition to the bridewealth, one or two male and female slaves to fill the space left by the bride on her removal to her husband's clan. The slaves were called *hilu kandutuku*, 'replacement(s) of the stake', which, he says, expresses the idea that the bride's removal is like the pulling up of a post that reinforces a corner of the natal house. Later, Kapita states, a horse, buffalo, gold, or a set of gongs was given in place of the slaves. I never heard of this practice in Rindi.
 - 20 '... the bride-price has less to do with sexual rights... than with the permanent loss of the wife and her offspring.' (Lévi-Strauss 1969:260).
 - 21 We might note here van Ossenbruggen's (1935:13) interpretation of the cloth (*oelos*) provided by the wife-givers among the Toba Batak as something in which the recipient is 'cloaked' and thus 'insulated' from the harmful influences of the outside world. In Rindi, however, it is rather metals that are associated with beneficent spirits and hence with the protection they provide against harmful, extraneous forces.
 - 22 In Rindi, both cloths and metal pendants exchanged in minor negotiations between allied groups (e.g., when setting a time for future meetings) are called 'knots' (*kawuku*), as they constitute symbols of an agreement conceived as a bond. Since the item received is also regarded as evidence that the exchange has taken place, the Rindi sometimes translate *kawuku* in this context with the Indonesian word *bukti*, 'proof' (see also Kapita 1976a:179). Because in this regard the onus is mainly on the wife-taker, however, it is more usually the cloths which are spoken of in this way.
 - 23 This emphasis is also reflected in the eastern Sumbanese practice, noted by Onvlee in his article on Mangili (1949:452), of referring to (the major components of) bridewealth and counter-prestation as *banda* and *kamba*

- (‘cloth’, ‘cotton’) respectively. *Banda* is related to Indonesian *benda*, originally a Sanskrit word, which means ‘(inanimate) thing, article’ and ‘wealth’.
- 24 During this century, an export market in decorated textiles has developed in the port of Waingapu. Thus these items, too, have acquired a commercial value, and a good cloth can now sometimes command the same price as a horse. However, relatively few of the decorated cloths made in Rindi are sold commercially.
 - 25 With regard to asymmetric alliance in Kédang, Barnes (1974:293) remarks that ‘Competition for bridewealth appears... only in the absence of a system’. Similarly, for the Atoni, Schulte Nordholt (1971:108) notes that with marriages that initiate an alliance the bridewealth will be higher and subject to protracted negotiations.
 - 26 Kédang also differs from Rindi in that bridewealth there mainly comprises ‘very expensive objects’ which have virtually no other use than as marriage prestations. Furthermore, in this case it is counter-prestation rather than bridewealth valuables that are more readily characterized as consumer goods (Barnes 1974:282, 283). In these respects too, then, the exchange has less of an economic character than it apparently does in Rindi.
 - 27 Vergouwen (1964:44) makes the same point with regard to the notion that the Batak ‘buy’ their wives. Specifically, he states that if this is so ‘... it is rather difficult to understand that relations can still be maintained between the two parties after this transaction’.

CHAPTER XVIII

- 1 In ritual language, the inspection is called ‘to go and survey the pasture that is full (i.e., of horses), the dale that is full, to peer behind the partition, to turn one’s head towards the crack in the wall’ (*lua pangaduya na pada mapaihi, na lola mapaihi, njingi la hambeli kâkatu, mbaili la manggawa hemiru*; cf. Onvlee 1973:85).
- 2 Onvlee (1949:451; 1973:85) translates this phrase as ‘to give poison to eat’, and suggests that by partaking of the meal a person in effect swears to fulfil his obligation, lest the meat work as poison. This, however, was denied in Rindi; and it seems that here Onvlee may have confused *kangâta*, ‘small piece of meat, morsel’, with *mangâta*, the name of a type of plant with poisonous roots.
- 3 E.g., setting the time for a transaction to take place, a procedure known as *kawuku rehi*, ‘to knot the time’, which refers to the former practice of tying knots in a length of cord to represent a number of days.
- 4 The procedure is also known in Rindi as *âpa kawini*, ‘to seize a woman’, (*âpa* has the additional senses of ‘to catch, grasp, hold’). In his brief description of eastern Sumbanese marriage practice, Kapita (1976a:124), on the other hand, gives the name as *pamamoha*, ‘to employ a *mamoha*’.
- 5 Roos (1872:51) says the woman (or, in his words, ‘the bride’) is draped in six or seven cloths; hence the skirt that covers her shoulders is possibly a minimal quantity.
- 6 At one marriage I attended, which did not include a *mamoha*, a single container was thrown at the wife-takers just after the main portion of bridewealth was transferred. The custom, called ‘to rub with the remains of meat, to pelt with containers of ash’ (*ruhingu tai tolungu, tukungu kaba aü*), is somewhat reminiscent of the placing of coconut shells filled with ash (*kaba aü*, a term which in some parts of Sumba is used to refer to the land

of the dead) outside the village to mark the departure of the souls of the deceased after the *langu paraingu* (feast of souls) ceremony. This suggests, then, that here ash might in part be linked with transition (see further Section 3 below).

- 7 In Rindi, I never heard that 'small gifts of clothing and ornaments' are also exchanged at this time, as Onvlee (1973:94) states.
- 8 Van Gennep's statement (1960:118) that in marriage '... protective and fertility rites actually seem to be inserted somewhat haphazardly among the rites of passage' agrees fairly well with Rindi practice.
- 9 The complete form of this expression, *na papa, na puru tanangu*, can also denote the entirety of rites that mark the completion of the marriage (*papa* is an abbreviation of *pamäi papa*).
- 10 Van Gennep's (1960:131) interpretation of bride substitution as '... an attempt to avoid a weakening of the interested groups... by relinquishing or uniting only individuals who are least valuable socially and especially economically...', finds some support in Rindi usage. Not only is the young girl of low class standing, but she is designated with phrases that play down her value, e.g., 'the one who uses (wears?) a pig's tail, who winds banana tree bark (?)' (*na matungu kiku wei, makunjilungu hapu*) and 'the one who wears a tin bracelet' (*na mandolungu tambura*). The last phrase seems not to describe her actual attire. A (slaughtered) pig's tail is something worthless, which is given to children to play with.
- 11 Under the heading of *tama la kurungu*, Onvlee (1973:82-94), referring to eastern Sumba in general, outlines a procedure rather different from that described to me in Rindi. In fact, in some respects it appears to have more in common with *äpa mamoha* marriage, which Onvlee does not mention as such.
- 12 Onvlee (1973:87) calls this prestation the 'head of the bridewealth' (*katiku wili*), an expression I cannot recall hearing in Rindi. The gift is of course reciprocated with cloths; but since the amounts of counter-prestation exchanged for standard increments of bridewealth were indicated in the previous chapter, I shall not mention them in every instance.
- 13 Whereas Onvlee (1973:90) says he steps on one of the hearthstones, I was assured in Rindi that it should be the ash. (As noted, *tuluru* can refer either to a set of three hearthstones or to a single stone.)
- 14 In the case of a nobleman from the Kanatangu district married in this way to a Rindi noblewoman (both of whom are now deceased), the husband, I was told, hardly ever visited his wife in Rindi, where she remained until her death. In fact, it seems that from the beginning of the marriage he never maintained residence there for any length of time either.
- 15 In this situation, when bridewealth has been outstanding for a very long time and so is no longer an issue, the wife-giver refers to the wife-taker as 'my child who is left in the horse and buffalo pasture' (*anangu pabànjalu la pada njara, la pada karimbua*).
- 16 While Onvlee (1973:99) says the initiative in this case is taken by the spouses themselves, in Rindi I was told that their parents arrange the marriage in advance, and that the groom is then sent to the bride's house by his father. It should be noted, however, that in this as in other abbreviated marriage procedures, the union is nevertheless represented as having come about entirely in accordance with the wishes of the young couple. In ritual speech, they are thus spoken of as 'the ones who have used a deer's (or damaged) heart, who have followed their own minds (livers)' (*da mawàngu kuku ruhada, eti wikida*), an expression which otherwise refers to persons who marry against their parents' wishes.

- 17 In simpler forms of contracting marriage, this final prestation is considered a 'reflexion' (*mai*) of the *kundu patini*, *tularu epi*, the main portion of bridewealth due to the bride's parents in marriages that involve a full bride-wealth. It is not formally designated with this expression, however.
- 18 Although some members of the wife-giving clan might have prior knowledge and approve of the wife-takers's intentions, I never heard that the bride's mother is normally aware of the plan, as Kruyt (1922:506) claims; nor it is clear why she should be.
- 19 This seems to be what Kapita (1976a:124) and Onvlee (1973:97) refer to as *pahangerangu*, 'to lean on, be dependent upon', a word which, so far as I know, is not regularly employed in this context in Rindi. Onvlee, however, uses the term in a wider sense, to include *pandengi* and what he describes as a simplified form of *hariungu*. In Rindi, *pahangerangu* (or the equivalent *pahanderangu*) was sometimes applied to the situation of commoner clients of the nobility (see Chapter X).
- 20 It is useful to compare the situation of such groups with that of lineages that derive from persons recruited to the mother's 'descent group' among the Atoni (Cunningham 1967:8-9). These persons may similarly continue to marry women of the mother's group (who are recruited through their fathers), in which case no bridewealth is necessary. The major difference between this pattern and *lalei ndàdiku* marriage, then, is that in accordance with the more consistently patrilineal ideology of the eastern Sumbanese, the children in the latter case are not formally incorporated into the mother's clan. Interestingly, Cunningham (*ibid.*:10) describes recruitment to Atoni descent groups through the mother as an analogue of the practice of affinal alliance and notes that the position of such persons, in relation to members recruited through their fathers, is analogous to that of wife-taking affines (*ibid.*:7).
- 21 A union which reverses the direction in which women are transferred between two clans, however, might be expedited in this way, provided the relation of the spouses is not too close and their agnates are prepared to recognize the marriage.
- 22 The prestation is called 'what is left at the head of the mat, beneath the pillow' (*pabànjalu la katiku topu, la lumbu nulangu*).
- 23 The mother's brother's part in elopement might also be compared to that of the husband's wife-giver in adultery, as both contexts involve a dispute between the principal and another group concerning the former's women. In each instance, moreover, the wife-giver's role appears to be essentially that of an intermediary. Wife-givers in Rindi may be called upon to serve as intermediaries in other circumstances as well, e.g., in settling disputes between distinct groups of wife-takers.
- 24 Another name is *piti maranggangu*, 'to take while meeting' (see Kapita 1976a:125), which evidently refers to the meeting of the two parties outside the village.
- 25 In Rindi, this aspect of the relationship is described as 'transferring back and forth what is raw and what is cooked' (*paluangga mai mamemi mamata*; see Onvlee 1949:458, who records a similar expression from Mangili). The aforementioned expression 'rising (to go) back and forth, fetching to and fro' (*hada luangga mai, piti luangga mai*), which refers as well to the status of the groom at the intermediate stage of *tama la kurungu* marriage, is also used in this regard.
- 26 In parallel speech, such marriages are described as *wulu dalungu, pandoi dalungu*, 'to create and make inside'. As noted, the inside referred to here is represented as a house, specifically that of the wife-giver.

- 27 This may be compared to the situation Cunningham (1966:17) describes for the Atoni, among whom bridewealth is higher the further outside a restricted 'local area' marriage takes place.

CHAPTER XIX

- 1 While most independent descent groups in Rindi are able to trace genealogical connexions between all living members, in a few instances lineages that formed single corporate groups and recognized a single ancestral house consisted of two or more lines, the exact relationship between which could not be remembered. In these cases, I have treated the entire group (and not the component lines) as a single unit for the purposes of reckoning alliances.
- 2 Marriages with wife-givers of wife-giving clans are not counted as ones with established affines, except, of course, where marriages have previously been contracted with such groups.
- 3 I include here marriages with the mother's half brother's daughter.
- 4 Barnes has informed me that the figure of '16 or 17 per cent' given in this place was a printing error. This should have read '116 [cases out of 687] or 17 per cent'.
- 5 This figure refers to a total of 25 marriages as a proportion of 687 cases where it was possible to tell whether the wife was taken from the mother's brother's clan (Barnes, personal communication, 1980). Of the 116 marriages that did involve a woman from this clan, these represent 21 per cent, and of the 95 cases where it could be determined whether a genealogical MBD had been married 26 per cent (*ibid.*).
- 6 The sample comprises over 700 marriages of Ema males. A further 11 per cent of unions involved *beibei* alliances, where a woman was taken from the wife-givers of wife-givers, while in only 12 per cent of cases were the groups previously unrelated. There were no incorrect (direct exchange) marriages.
- 7 As Barnes himself notes (1974:303), there is probably no clear point at which the incidence of marriages that are irregular in terms of existing alliances becomes so high that a 'system' can no longer exist.
- 8 In one case, for example, a woman whose daughter had recently eloped with a man of an unrelated group stated in exasperation that her (husband's) clan would soon have *kalembi hama rumba*, which freely translated means 'as many affines as there are blades of grass'.
- 9 The distinction between higher and lower rank with respect to groups is necessarily somewhat arbitrary, since those that contain members of the higher commoner class (*kabihu bokulu*) also include a number of persons of lower commoner (*kabihu kudu*) rank (see Chapter X). For the present purposes, however, groups that can reasonably be considered to be of high class standing include the six lineages of the noble clan, eight commoner clans whose members have taken wives from minor nobility (*maràmba kudu*) or given women to noble lineages (outside Rindi), plus six others which include a significant proportion of members of *kabihu bokulu* standing. (While, arguably, some other Rindi clans could be added to the latter category, if this were done the results would not be greatly affected.) The remaining 46 groups, therefore, are all counted as ones of lower rank.
- 10 Since I have here distinguished groups on the bases of size and rank, I should also mention that with regard to direct exchange (i.e., incorrect

- unions) the various samples reveal a variation of only between 3.2 (for the 46 lower ranking groups) and 3.9 per cent (for the 20 smallest groups) of total marriages, excepting the six noble lineages, among whom there was only one case (thus 0.84 per cent of their total marriages) of direct exchange.
- 11 In this respect, the system may be compared with that of the Kachin, for whom Leach (1954:77) reports that only persons of high status 'need strictly conform to the *mayu-dama* rules'. In the case of the Matupi Chin, on the other hand, Lehman (1970:118) states that the preference for marriage with the 'real or classificatory MBD' is outweighed by a preference for diversifying alliances to one's own political advantage. Among the higher classes in Rindi, however, it is on the contrary clearly often to their advantage, in respect of one sort of political consideration at any rate, to perpetuate established ties of alliance.
 - 12 Clearly, it would be useful to have more comparative data in order to investigate whether this correlation might not also obtain in other instances of this sort of system.
 - 13 The difference between the two figures reflects the lower number of women's marriages included in the genealogical record for Rindi as a whole.
 - 14 The procedure that was followed by the clan Kanatangu (the largest commoner clan in terms of current size in Rindi) at the exchange of funerary prestations after the burial of one of its most prominent members is relevant in this regard. For this purpose, Kanatangu, which has recently been involved in several cases of direct exchange, separately — and apparently without compunction — received pairs of agnates belonging to the same affinal clan as wife-givers and wife-takers respectively. It should also be recalled that at funerals generally, sometimes individual men, even full brothers, will separately exchange prestations with the same group of affines (see Chapter IX).
 - 15 Among men's marriages contracted within Rindi, I found 4 cases involving close relatives from the clan of the FBW, including 3 with FBWBD and one with FBWBSD. There were also 9 such marriages with women from the natal clan of the mother's co-wife (FW), including at least 3 with FWBD, which clan is positionally equivalent to that of the FBW.
 - 16 In these instances, Rindi marriage arrangements are reminiscent of what Barnes (1974:302) describes for Kédang. In contrast to the latter society, however, where corporate action extends beyond the alliance group in Rindi, this group is always named and hence readily distinguishable in respect of actual alliance connexions.
 - 17 Of course, a group can also give wives to a clan segment localized in one domain while taking wives from another segment of the same clan resident elsewhere.
 - 18 This is also expressed with the phrases 'the steam does not leave the rice, the aroma does not go out of the chicken' (*nda na-luhu na kutu na uhu, nda na-luhu na hiritu na manu*).
 - 19 Lehman's (1970:118) remarks on cyclical marriages among the Chin are relevant here. Such arrangements, he notes, rarely result in the 'actual closure' of a cycle; for after a wife-giver has contracted a marriage that initiates a cycle, he may never 'get the equivalent woman back', since by the time he is ready to take a wife, relations between his group and that of his own wife-giver may well have lapsed.
 - 20 As I did not have time to collect extensive genealogies in Nàpu, only a list of alliance relations between local clans, this finding must be regarded as provisional.

- 21 Since men's and women's marriages are counted separately, these represent 22 unions or 3.5 per cent of the total of 638.
- 22 Another three marriages involved BWZ and ZHB. In the other five, the women were related as BWFD, FBWBD, FSWFBD, and FFFFSSSSWZ.
- 23 To some extent, the possibility of marriage could of course be determined by the way in which the relationship terminology is applied. Thus, while slaves of the same clan call one another by the terms for agnates, where a marriage has taken place between two families the affinal terms are employed. But it is not clear for how long, in the absence of further marriages, this classification is retained, or how extensively the terms are applied on either side. Moreover, marriage between persons not previously classified as affines is also possible.
- 24 As noted, marriages with *ata ngàndi* constituted 40 per cent of unions of male slaves of the nobility contracted outside the clan. These, then, represent 22.5 per cent of all marriages of such male slaves.

CONCLUDING REMARKS

- 1 With regard to Sumbanese dual classification, Onvlee has written: 'One sometimes gets the impression that a unit cannot exist without a partner, that it must be a unit in a duality, a duality in a unity; the unit is only fulfilled in the duality' (1973:106).
- 2 This is not argue that classifications other than fundamentally dualistic ones are (or need be) absent in Rindi, however. Indeed, the system of social classes, a most prominent feature of the social order, is manifestly tripartite. But even in this case binary distinctions are apparent. Thus there is the idea that the lowest of the three classes, the slaves, at one time did not exist, while in certain respects the present hierarchy is represented, by the nobility and their slaves, as consisting of just two classes, the *maràmba* and the *ata*.
- 3 I hope to make available soon an extended account of eastern Sumbanese notions of time and Rindi classifications relating to temporal processes (see Forth, in preparation).
- 4 In this regard, we might further recall the funerary custom whereby female mourners address the corpses of members of all ascending genealogical levels with the terms for 'mother' and 'father'.

GLOSSARY

The following is a list of the eastern Sumbanese words and phrases which most commonly appear, or are most frequently referred to, in the text. The definitions provided here are not always exhaustive, and in most cases more detailed explanations are to be found in the text, either where the term is first introduced or subsequently. Sub-entries included under various headings are intended as examples rather than as complete indices of the phrases in which words occur. As regards orthography, the reader should refer to the Introduction, pp. 17-18.

<i>ama bokulu</i>	'big, great father', male elder, priest, ritual expert, clan headman
<i>ana</i>	child (offspring), person; small version or quantity; shorter sides of (rectangular) house
<i>anakeda</i>	child (infant), immature person; way of addressing and referring to slaves
<i>anakawini</i>	wife-taker (<i>kawini</i> , female; see <i>layia</i> ; cfr. <i>ana kawini</i> , female child, daughter)
<i>angu</i>	companion, mate; spouse (in address)
<i>angu kabihu</i>	clan mate, fellow clansman
<i>angu kotakungu</i>	co-villager, village mate
<i>angu paluhu</i>	'companion in emergence', men's term for B, FBS, etc. (see Table 1)
<i>ata</i>	slave, the class of slaves and hereditary retainers
<i>ata bokulu</i>	major slave; higher ranking stratum of the <i>ata</i> class
<i>ata kudu</i>	minor slave; lower ranking stratum of the <i>ata</i> class
<i>ata ngàndi</i>	unmarried woman, usually of slave rank, who accompanies a noble bride to her marital home to serve her there
<i>aya</i>	elder, older (person), senior, superior; term of address for elder siblings, etc. (see Tables 3 and 4)
<i>aya willi</i>	principal part of the bridewealth (see <i>wili</i>)
<i>bai</i>	big, great; female, mother (of animals); longer sides of (rectangular) house
<i>banda</i>	goods, wealth, moveable property (especially livestock); also applied to bridewealth as opposed to counter-presentation valuables; (non-human) animals in general
<i>banda la maràda</i>	goods on the plain, large livestock
<i>banda la uma</i>	goods in, of the house

<i>bànjalu wai mata</i>	'to put away the tears', ceremony marking the end of mourning after the funeral
<i>dekangu</i>	to predestinate, determine the fate of; to determine a child's name (and hence fate); to curse; to solve (a riddle)
<i>eri</i>	younger (person), junior, inferior; term of address for younger siblings, etc. (see Tables 3 and 4)
<i>eri wili</i>	minor increments of bridewealth
<i>eti</i>	liver; heart, as, e.g., in <i>jangga eti</i> , 'high hearted', i.e., arrogant, proud
<i>halela</i>	light (of weight); easy, unimportant, of little consequence; young (of persons); inexpensive
<i>hamangu</i>	soul; consciousness, conscience; enthusiasm
<i>hamayang</i>	invocation, the act of addressing forms of spirit, especially the clan ancestor
<i>hàngguru</i>	ceremony at which a child is first formally introduced to the clan ancestor and deceased members of the clan
<i>hilu</i>	to change, exchange, replace; replacement; language
<i>hilu Humba</i>	Sumbanese language
<i>hilu ngara,</i> <i>hilu tamu</i>	replacement of the title and name, child conceived as the replacement of the deceased forbear whose name he bears
<i>hinggi</i>	length of material worn by men as a loin-cloth (<i>hinggi pakalambungu</i>) or shoulder cloth (<i>hinggi paduku</i>)
<i>huri</i>	culture, customs; religion; rite; manners, behaviour
<i>kabihu</i>	corner; patrilineal clan or lineal segment of a clan; the commoner class
<i>kabihu bokulu</i>	major commoners, the higher stratum of the commoner class
<i>kabihu kudu</i>	minor commoners, the lower stratum of the commoner class
<i>tau kabihu</i>	'clan person', the commoner class
<i>kaheli</i>	raised floor of a house
<i>kalembi</i>	shirt, blouse, or other tailored garment that covers the upper part of the torso; affines, both wife-givers and wife-takers; also applied to the relation of a married woman and her parents
<i>kaloka</i>	row, line, section; descent line, lineage, named lineal segment of a clan
<i>kalumbutu</i>	man's betel and areca container or bag, carried under the arm

<i>kamba</i>	cotton; cloth goods; also used to refer to counter-presentation goods in general
<i>kambata</i>	upstream end or section of a village, especially the chief village (<i>paraingu</i>)
<i>kàni</i>	centre, central section of the (chief) village
<i>kàpu</i>	woman's betel and areca container
<i>kapuka</i>	tip, top, upper part, particularly of a tree or other plant (opposite of <i>pingi</i> , see below)
<i>katiku</i> <i>katiku tana</i>	head head of the island, the eastern extremity (or part) of Sumba; Head of the Earth, the region in which the major eastern Sumbanese rivers have their sources (opposite of <i>kiri awangu</i> , see below)
<i>katoda</i>	altar, place of offering consisting of a stone or stones placed at the foot of a wooden stake or tree
<i>kawarungu</i>	mortuary house, built atop the grave of a noble person
<i>kawini</i>	woman, female, feminine
<i>kawudu</i> <i>rii kawudu</i>	joint (of human or animal body); points of branching on a tree or other plant; swelling 'jointed bones', bones of humans, large animals
<i>kawuku</i> <i>kawuku uma</i>	knot, joint; top knot (of hair), bun triangular peak or tower of a house (<i>uma</i>)
<i>kikiru matua</i>	'mature shearing', rite involving the cutting of an adult's hair
<i>kiku</i> <i>kiku tana</i>	tail; downstream end or section of a village tail of the island, the western extremity (or part) of Sumba
<i>kiri</i> <i>kiri awangu</i>	base, beginning, foot Base of the Sky, the place of origin of the first ancestors of the patrilineal clans; the horizon
<i>kiri ulu</i> or <i>kiri kaheli</i>	the back part of a house (<i>ulu</i> , hilt; <i>kaheli</i> , house floor)
<i>kotaku</i>	village subsidiary to the chief village (<i>paraingu</i>)
<i>laü</i>	tubular skirt worn by women
<i>layia</i>	men's term of reference for FZS, ZH, etc. (see Table 1); women's term for HZH, etc. (see Table 2); wife-takers (see <i>anakawini</i>)
<i>lii</i> <i>lii luri</i>	word, speech; matter; rite matters concerning life, life rites

<i>lii marapu</i>	matters concerning the clan ancestor, ancestral myths
<i>lii meti</i>	matters concerning death, mortuary usages and ceremonies
<i>lindi</i>	bridge, connexion
<i>lindi woru,</i> <i>lindi bàba</i>	'bridge of fertility and prolificity', the connexion between the mortal world and the world of spirit providing the means of life and prosperity
<i>luluku</i>	parallelistic ritual language, in particular that employed by the <i>wunangu</i> (see below)
<i>lalei</i>	to marry (a woman) (cf. <i>mangoma</i>)
<i>lalei tama</i>	form of marriage, without bridewealth, where a man and his children become incorporated into the wife's natal clan (<i>tama</i> , to enter)
<i>langu paraingu</i>	feast of souls ceremony, a ceremony of renewal now largely in abeyance, during which the deceased in the land of the dead visit the habitations of the living to be feasted and entertained by them
<i>mabara</i>	'what is white', silver and silver-coloured metals
<i>mamarungu</i>	witch, also loosely applied to thieves, trouble-makers
<i>mameti</i>	corpse, (soul of) a dead person; the dead, deceased forbears as distinct from the earliest ancestors (<i>marapu</i> , see below)
<i>mamoha</i>	a (noble) bride's substitute, an unmarried girl of slave or lower commoner rank who takes the place of the bride during the marriage ceremonies
<i>àpa mamoha</i>	'to seize a <i>mamoha</i> ', the high, most complete form of marriage as practised by the nobility
<i>mamuli</i>	metal pendant, used mostly as bridewealth and in other prestations to wife-givers
<i>mangapangu</i>	privilege of requesting, and taking forcibly if refused, livestock and other foodstuffs, accorded to persons occupying a special ritual status (e.g., initiates)
<i>mangoma</i>	to marry, be married (of a woman)
<i>mangu tanangu</i>	'owner of the land', earliest clan or clans to settle in a territory; the ancestor of such a clan
<i>mangu umangu</i>	'owner of the house', principal householder or all the inhabitants of a house
<i>maràda</i>	the plain, the uninhabited area of a domain outside the villages and their adjoining fields
<i>maràmba</i>	(person of) nobility, the noble class; (noble) ruler of a traditional domain

<i>maràmba bokulu</i>	major, higher ranking nobility (those of pure noble descent)
<i>maràmba kudu</i>	minor, lower ranking nobility (those who derive from female ascendants of commoner rank)
<i>maràmba tana</i>	lords, nobility of the earth, superior type of earth spirit
<i>marapu</i>	the first, deified ancestors of the clans; personage or thing identified or in some way associated with the first ancestors and possessing particular spiritual powers
<i>marapu mameti</i>	the dead who are completely assimilated into the after-world (see <i>mameti</i>)
<i>marapu wai maringu</i>	cool water deity, invoked in cooling ceremonies (see <i>wai maringu</i>)
<i>marara</i>	'what is red', gold and alloys of gold
<i>maringu</i>	cool; accessible, not restricted, free of religious injunction; salutary, affording prosperity
<i>mata</i>	eye; face, front; source, origin, beginning; focus, nucleus (often appears as the complementary term of <i>pingi</i> , see below)
<i>mata wai</i>	water source, spring, the source of a river; also used in ritual language to refer to wife-givers
<i>matua</i>	respected, revered; mature, adult, ripe (of fruit)
<i>tau matua</i>	adult (person) (opposite of <i>anakeda</i> , see above)
<i>maü</i>	shadow, reflexion; (place of) shelter, protection; replica, facsimile, copy
<i>maü la mara, ninu la wai</i>	'shadow on dry land, reflexion in the water', a (usually impoverished) copy or approximation of something, e.g., the present world by comparison to that of the ancestors
<i>mawulu tau, majii tau</i>	'maker and plaiter of men'; God, the Creator; the clan ancestor conceived as a creator
<i>mbana</i>	hot; powerful, (potentially) dangerous; excessive; infused with spirit and thus the object of ritual restrictions
<i>mbapa tunu, manahu</i>	'partners in burning (roasting) and cooking', set of six clans that serve as the ceremonial partners of the ruling, noble clan in Rindi
<i>mbola ngàndi</i>	'basket(s) brought along', counter-prestation to the bride-wealth
<i>mbotu</i>	heavy; difficult, demanding; serious, profound; expensive (opposite of <i>halela</i> , see above)
<i>meti maringu</i>	'cool', normal death
<i>meti mbana</i>	'hot', bad (mostly violent) death

<i>mini</i>	man (male person), male, masculine
<i>ndalihuh</i>	interval between joints (body) or points of branching (plant); generation, genealogical level
<i>ndaungu</i>	year, season
<i>ndaun urangu</i>	rainy, wet season
<i>ndaun wandu</i>	dry season
<i>ndekilu</i>	term with which another is paired in ritual language (also called <i>papa</i> , see below)
<i>ndewa</i>	spirit, life force, animating principle; divinity; fate, destiny, fortune
<i>ndewa-pahomba</i>	vital principle, life force, especially that associated with various altars (<i>katoda</i>) and the <i>pahomba</i> shrine (see below)
<i>ngangu uhu</i>	'to eat rice', common name for the first fruits ceremony
<i>ngara</i>	name; form of naming by which a noble person is referred to with the name of a slave, more completely known as <i>ngara hunga</i> , visible name; the slave who performs this function
<i>njuraku</i>	illicit sex, adultery, incest
<i>pahàpa</i>	'what is chewed', betel fruit (or, occasionally, leaf) and areca nut, chewed with lime
<i>pahili mbola</i>	'to take down the baskets', the final mortuary ceremony which marks the complete assimilation of the deceased into the land of the dead
<i>pahomba</i>	complementary term of <i>ndewa</i> (see above); clan shrine, a place of offering identified with the power(s) called <i>ndewa-pahomba</i>
<i>palai ngàndi</i> or <i>paluhu ngàndi</i>	elopement, marriage procedure initiated by elopement
<i>palua kalaingu</i>	'to move to the left', rule governing rites and usages concerned with death and the dead, and which is thought to govern life in the afterworld
<i>palua kawanangu</i>	'to move to the right', rule that defines proper order among the living, often expressed as an anti-clockwise movement or sequence
<i>papa</i>	one member of a pair; partner, counterpart, complement; competitor, enemy; (on) the other side (as a term of direction)
<i>papangganggu</i>	specially costumed attendant of a noble corpse

<i>paraingu</i>	chief village, principal settlement of a domain; also refers to the domain as a whole
<i>paraingu bokulu</i>	chief village (as opposed to the entire domain; <i>bokulu</i> , big, major)
<i>parai marapu</i>	'village of the ancestors', the village or land of the dead
<i>patidungu</i>	conjugal relationship entered into against the wishes of one or both of the spouses' groups
<i>pingi</i>	trunk, lower part of trunk, stem of tree or other plant; source, (place of) origin (opposite of <i>kapuka</i> , see above)
<i>pingi ai</i>	tree (<i>ai</i> is wood, wooden), source of wood; when conjoined with <i>mata wai</i> (see above) the phrase denotes wife-givers
<i>puru la wai</i>	'to descend to the water', youths' initiation ceremony involving incision of the penis
<i>ratu</i>	office of religious leader, complementary to that of noble ruler (<i>maramba</i>); in Umalulu held by a set of four clans. (The office is not formally recognized in Rindi.)
<i>rehi</i>	(point in) time; line, spatial or temporal boundary
<i>rehi pakawuku</i>	'knotted time', appointed, predefined time
<i>rii</i>	bone (see <i>rii kawudu</i> under <i>kawudu</i> above); vein, spine (of leaf); thorn; vegetable (see, e.g., <i>rii muru</i> , green vegetables); side dish; (prospective) wife
<i>rumba</i>	grass, small plants; weeds; wild, as, e.g., in <i>meu rumba</i> , wild cat; <i>wei rumba</i> , wild pig
<i>talora</i>	space between two rows; village square
<i>tamu</i>	name, namesake
<i>tana</i>	earth, world; land, island, country, domain; soil, ground
<i>tana Humba</i>	the island of Sumba
<i>tana mbana</i>	'hot', forbidden land that is inhabited by malicious earth spirits and so is not fit for human use
<i>tanggu marapu</i>	ancestral relics; clan heirlooms
<i>tau</i>	body, torso; person, human being; (with possessive pronoun) wife, slave
<i>tau uma</i>	'body, torso of the house', the upper section or peak of a house (cf. <i>kawuku uma</i>)
<i>tera</i>	cloth, a length of woven material; (man's) head cloth
<i>tera tamali</i>	veil; a woman's head scarf
<i>tulaku paraingu, lindiku maràda</i>	'supports of the chief village, props for the plain', a set of four commoner clans that serve as special supporters of the ruling, noble clan and whose names are used to designate the latter clan in formal speech

<i>uhu</i>	rice; food
<i>uhu kani</i>	millet
<i>uhu njara</i>	horse feed (<i>njara</i> , horse)
<i>uma</i>	house, building
<i>uma marapu</i>	ancestral house, oldest house of a clan that serves as the clan temple
<i>uma maringu</i>	'cool' house, ordinary residential house
<i>uma mbatangu</i>	peaked house, the typical form of the <i>uma marapu</i>
<i>ura</i>	sinew, vein, nerve; entrails of a fowl, used as an augury; fate, luck; soul (as complementary term of <i>hamangu</i> , see above, in ritual speech)
<i>wai maringu</i>	'cool water', ancestral deity or power invoked in cooling ceremonies; consecrated water used in these ceremonies
<i>wai maringu mànjaku</i>	'calm cool water', deity that neutralizes what is regarded as 'hot' (<i>mbana</i> , see above) and dispenses blessing and protection
<i>wai maringu mbana</i>	'hot cool water', deity complementary to the above that directly takes away what is 'hot'
<i>wataru</i>	maize
<i>wataru hàmu</i>	sorghum (<i>hàmu</i> , good, indigenous)
<i>wataru jawa</i>	maize (<i>jawa</i> , foreign)
<i>wili</i>	price, worth, value, use
<i>wili tau</i>	'price of the person', bridewealth
<i>woka</i>	cultivated field; the fields, the area immediately outside the village; the entire inhabited area outside the chief village (<i>paraingu</i>)
<i>tau la woka</i>	'people in, of the fields', used to refer to members of the commoner and slave classes as opposed to the nobility, whose principal houses are located in the chief village
<i>woru, bàba,</i> <i>wulu, pangàdangu</i>	'fertility and prolificity, wealth and mental acumen', qualities regularly requested from divinity (see <i>lindi woru</i> , <i>lindi baba</i>)
<i>wulangu</i>	moon; lunar month; season
<i>wula tua</i>	period of restriction lasting two to three lunar months that intervenes between the end of the wet season and the beginning of the dry season proper
<i>wunangu</i>	shuttle comb on a loom; ritual speaker, a specialist in the speech form called <i>luluku</i> employed in formal negotiations, especially those between affines

WORKS CITED

- Anon.
1853 'Bijdragen tot de kennis van het eiland Soemba of Sandelhout', *Tijdschrift voor Nederlandsch-Indië* 15-I:48-53.
1855 'Beschrijving van het eiland Soemba of Sandelhout', *Tijdschrift voor Nederlandsch-Indië* 17-I:277-312.
1926 'Begraven op Soemba', *Bijdragen tot de Taal-, Land- en Volkenkunde* 82:576-82.
1933 'Nota van toelichting aangaande het Landschap Rendih' (unpublished report), Koninklijk Instituut voor de Tropen, Amsterdam.
1947 'Vervulling vacature Zelfbestuurder Melolo. Waingapoe 13 Maart 1947' (unpublished report), Koninklijk Instituut voor de Tropen, Amsterdam.
- Abbott, J.
1932 *The Keys of Power: A Study of Indian Ritual and Belief*, London.
- Adams, M. J.
1970 'Myths and Self Image among the Kapunduku people of Sumba', *Indonesia* 10:81-106.
1974 'Symbols of the Organized Community in East Sumba, Indonesia', *Bijdragen tot de Taal-, Land- en Volkenkunde* 130:324-47.
- Andree, R.
1893 'Die Pleiaden im Mythos und in Ihrer Beziehung zum Jahresbeginn und Landbau', *Globus* 64, No. 229:362-6.
- Barnes, R. H.
1974 *Kédang: A Study of the Collective Thought of an Eastern Indonesian People*, Oxford.
1977a 'Mata in Austronesia', *Oceania* 47:300-19.
1977b 'Alliance and Categories in Wailolong, East Flores', *Sociologus* 27: 133-57.
1978 'Injunction and Illusion: Segmentation and Choice in Prescriptive Systems', *Anthropology* 2:19-30.
1979 'Lord, Ancestor and Affine: An Austronesian Relationship Name', *Nusa* 7:19-34.
1980 'Concordance, Structure and Variation: Considerations of Alliance in Kédang', in: J. J. Fox (ed.), *The Flow of Life*, Cambridge, Massachusetts.
- Bateson, G.
1958 *Naven* (2nd edition), Stanford, California.
- Blust, R. A.
1972 'Notes on PAN *qa(R)(CtT)a 'outsiders, alien people'', *Oceanic Linguistics* 11:166-71.

- 1979 'Proto-Western Malayo-Polynesian Vocatives', *Bijdragen tot de Taal-, Land- en Volkenkunde* 135:205-51.
- Bosch, F. D. K.
1960 *The Golden Germ: An Introduction to Indian Symbolism*, Indo-Iranian Monographs, Vol. 2, 's-Gravenhage.
- Brandstetter, R.
1916 *An Introduction to Indonesian Linguistics* (trans. C. O. Blagden), London.
- Cassirer, E.
1955 *The Philosophy of Symbolic Forms: Volume Two: Mythical Thought* (trans. Ralph Manheim), New Haven.
- Clamagirand, B.
1975 *Marobo: Organisation Sociale et Rites d'une Communauté Ema de Timor*, Thèse de Doctorat de 3 Cycle [Ethnologie], Ecole Pratique des Hautes Etudes, Université René Descartes (unpublished).
- Coomaraswamy, A. K.
1942 *Spiritual Authority and Temporal Power in the Indian Theory of Government*, American Oriental Series, Vol. 22: American Oriental Society, New Haven.
- Couvreur, A.
1917 'Aard en wezen der Inlandsche zelfbesturen op het eiland Soemba', *Tijdschrift voor het Binnenlandsch Bestuur* 52:206-19.
- Covarrubias, M.
1937 *Island of Bali*, New York.
- Cunningham, C. E.
1964 'Borrowing of Atoni Children: An Aspect of Mediation', in: M. E. Spiro (ed.), *Proceedings of the American Ethnological Society, 1964*, Seattle.
1965 'Order and Change in an Atoni Diarchy', *Southwestern Journal of Anthropology* 21:359-82.
1966 'Categories of Descent Groups in a Timor Village', *Oceania* 37:13-21.
1967 'Recruitment to Atoni Descent Groups', *Anthropological Quarterly* 40:1-12.
1973 'Order in the Atoni House', in: Rodney Needham (ed.), *Right and Left: Essays on Dual Symbolic Classification*, Chicago and London.
- Dammerman, K. W.
1926 *Een tocht naar Soemba*, Batavia.
- Dempwolff, O.
1938 *Austronesisches Wörterverzeichnis (Vergleichende Lautlehre des Austronesischen Wortschatzes, Vol. 3)*, Beihefte zur Zeitschrift für Eingeborenen-Sprachen, No. 19, Berlin.
- Dijk, W. van
1939a 'Het begrip Marapoe in West-Soemba', *Bijdragen tot de Taal-, Land- en Volkenkunde* 98:497-516.
1939b 'Het monogame huwelijk in de inlandsche kringen en gemeenten', *De Macedoniër* 43:193-206.
- Dumézil, G.
1948 *Mitra-Varuna: essai sur deux représentations Indo-Européennes de la souveraineté*, 2nd edition, Paris.

- Dumont, L.
 1957 *Hierarchy and Marriage Alliance in South Indian Kinship*. Occasional Papers of the Royal Anthropological Institute of Great Britain and Ireland, No. 12, London.
- Duyvendak, J. Ph.
 1946 *Inleiding tot de ethnologie van de Indonesische archipel*, Groningen and Djakarta.
- Echols, J. M. and Shadily, H.
 1963 *An Indonesian-English Dictionary*, 2nd edition, New York.
- Encyclopaedie van Nederlandsch-Indië*. Vol. 4:1-7. The Hague, 1921.
- Endicott, K. M.
 1970 *An Analysis of Malay Magic*, Oxford.
- Esser, J.
 1877 'Aanteekeningen over Soemba', *Tijdschrift voor Nederlandsch-Indië* 6-II:161-9.
- Firth, R.
 1963 'Bilateral Descent Groups: An Operational Viewpoint', in: I. Schapera (ed.), *Studies in Kinship and Marriage*, Royal Anthropological Institute Occasional Paper No. 16, London.
- Fischer, H. Th.
 1952 *Inleiding tot de culturele anthropologie van Indonesië*, Haarlem.
 1957 'Some Notes on Kinship Systems and Relationship Terms of Sumba, Manggarai and South Timor', *Internationales Archiv für Ethnographie* 48:1-31.
- Fischer, H. Th. and Renselaar, H. C. van
 1959 'Over enkele Batakse Verwantschapstermen', *Bijdragen tot de Taal-, Land- en Volkenkunde* 115:40-55.
- Forth, G. L.
 1974 *Some Problems in the Analysis of Social Structure on Sumba in Eastern Indonesia*, B.Litt. thesis, The University of Oxford (unpublished).
in preparation 'Time and Temporal Classification in Rindi, Eastern Sumba'.
- Fox, J. J.
 1968 *The Rotinese: a Study of the Social Organization of an Eastern Indonesian People*, D.Phil. thesis, The University of Oxford (unpublished).
 1971a 'Semantic Parallelism in Rotinese Ritual Language', *Bijdragen tot de Taal-, Land- en Volkenkunde* 127:215-55.
 1971b 'Sister's Child as Plant: Metaphors in an Idiom of Consanguinity', in: Rodney Needham (ed.), *Rethinking Kinship and Marriage*, A.S.A. Monographs 11, London.
 1973 'On Bad Death and the Left Hand: A Study of Rotinese Symbolic Inversions', in: Rodney Needham (ed.), *Right and Left: Essays on Dual Symbolic Classification*, Chicago and London.
 1977 *Harvest of the Palm: Ecological Change in Eastern Indonesia*, Cambridge, Massachusetts and London.
- Fox, J. J. and Fox, I.
 n.d. *A Working Bibliography on the Islands of Roti, Savu, and Sumba in Eastern Indonesia* (unpublished).
- Genep, A. van
 1960 *The Rites of Passage* (trans. M. B. Vizedom and G. L. Caffee), Chicago.

- Grijzen, H. J.
1904 'Mededeelingen omtrent Beloe of Midden-Timor', *Verhandelingen van het Bataviaasch Genootschap van Kunsten en Wetenschappen*, Vol. 54.
- Heijden, A. J. van der
1923 'Onderafdeelingsnota betreffende de landschappen in Midden Soemba. Verbaal: 15 Maart 1923, No. 77. Mailrapport 4353/32' (unpublished report), Archief van het Ministerie van Binnenlandsche Zaken, Den Haag.
- Heijmering, G.
1846 'Bijdrage tot de kennis van de taal der zuidwester eilanden, benevens een proeve van vergelijking derzelve met achte andere inlandsche talen', *Tijdschrift voor Nederlandsch-Indië* 8-III:1-81.
- Hertz, R.
1960 *Death and the Right Hand* (trans. Rodney and Claudia Needham), London.
- Hicks, D.
1976 *Tetum Ghosts and Kin: Fieldwork in an Indonesian Community*, Palo Alto, California.
- Hocart, A. M.
1970 *Kings and Councillors: An Essay in the Comparative Anatomy of Human Society*, Chicago and London.
- Humme, H. C.
1876 'Aanteekeningen tot de bijdrage van den Heer Teffer over het eiland Savoe', *Tijdschrift voor Indische Taal-, Land- en Volkenkunde* 23:359-60.
- Jensen, A. E.
1947- 'Wettkampf-Parteien, Zweiklassen-Systeme und Geographische Orientierung', *Studium Generale* 1:38-48.
- Jonker, J. C. G.
1893 'Bimaneesch-Hollandsch Woordenboek', *Verhandelingen van het Bataviaasch Genootschap van Kunsten en Wetenschappen*, Vol. 48.
- Kapita, Oe. H.
1974 *Kamus Sumba Timur-Indonesia* (unpublished manuscript lent by the author).
1976a *Masyarakat Sumba dan Adat Istiadatnya*, Waingapu.
1976b *Sumba di dalam Jangkauan Jaman*, Waingapu.
- Kate, H. F. C. ten
1894 'Verslag eener reis in de Timorgroep en Polynesië', *Tijdschrift van het Koninklijk Nederlandsch Aardrijkskundig Genootschap* 11:195-246, 333-390, 541-638, 659-700, 765-823.
- Korn, F.
1973 *Elementary Structures Reconsidered: Lévi-Strauss on Kinship*, London.
- Kruyt, A. C.
n.d. *Het animisme der Indonesiërs*, Oegstgeest.
1906 *Het animisme in den Indischen Archipel*, 's-Gravenhage.
1921 'Verslag van eene reis over het eiland Soemba', *Tijdschrift van het Koninklijk Nederlandsch Aardrijkskundig Genootschap* 38:513-53.
1922 'De Soembaneezen', *Bijdragen tot de Taal-, Land- en Volkenkunde* 78: 466-608.
1923 'De Timoreezen', *Bijdragen tot de Taal-, Land- en Volkenkunde* 79: 347-490.

- 1973 'Right and Left in Central Celebes' (trans. Rodney Needham), in: Rodney Needham (ed.), *Right and Left: Essays on Dual Symbolic Classification*, Chicago and London.
- Lambooy, P. J.
 1926 'Het tatoeëeren bij de Soembaneezen', *De Macedoniër* 30:137-9.
 1927 'Sporen van oudere bevolking op Soemba', *De Macedoniër* 31:232-8.
 1930 'De Godsnaam op Soemba', *De Macedoniër* 34:275-84.
 1937 'Het begrip 'Marapoe' in den godsdienst van Oost Soemba', *Bijdragen tot de Taal-, Land- en Volkenkunde* 95:425-39.
- Leach, E. R.
 1954 *Political Systems of Highland Burma: A Study of Kachin Social Structure*, Boston.
 1961 *Rethinking Anthropology*, London School of Economics Monographs on Social Anthropology, No. 22, London.
 1962 'On Certain Unconsidered Aspects of Double Descent Systems', *Man* 62:214.
 1967 'Magical Hair', in: J. Middleton (ed.), *Myth and Cosmos: Readings in Mythology and Symbolism*, Garden City, New York.
- Lehman, F. K.
 1963 *The Structure of Chin Society: A Tribal People of Burma Adapted to a Non-Western Civilization*, Illinois Studies in Anthropology, No. 3, Urbana.
 1970 'On Chin and Kachin Marriage Regulations', *Man* 5:118-25.
- Le Roux, C. C. F. M.
 1929 'De Elcano's tocht door den Timorarchipel met Magalhaes' Schip 'Victoria', in: *Feestbundel uitgegeven door het Koninklijk Bataviaasch Genootschap van Kunsten en Wetenschappen bij gelegenheid van zijn 150 jarig bestaan, 1778-1928*, Vol. 2, Weltevreden.
- Lévi-Strauss, C.
 1963 *Structural Anthropology* (trans. C. Jacobson and B. G. Schoepf), New York and London.
 1969 *The Elementary Structures of Kinship* (trans. Bell, Sturmer, and Needham), Boston.
- Lévy-Bruhl, L.
 1965 *The 'Soul' of the Primitive* (trans. L. A. Clare), London.
 1966 *How Natives Think* (trans. L. A. Clare), New York.
- Na Paràndingu Bidi* [The New Testament in Kambara], Djakarta, 1961.
- Needham, R.
 1954 'A Penan Mourning Usage', *Bijdragen tot de Taal-, Land- en Volkenkunde* 110:263-7.
 1957 'Circulating Connubium in East Sumba: A Literary Analysis', *Bijdragen tot de Taal-, Land- en Volkenkunde* 113:168-78.
 1958 'A Structural Analysis of Purum Society', *American Anthropologist* 60:75-101.
 1960a 'The Left Hand of the Mugwe: An Analytical Note on the Structure of Meru Symbolism', *Africa* 30:20-33.
 1960b 'Structure and Change in Asymmetric Alliance: Comments on Livingstone's Further Analysis of Purum Society', *American Anthropologist* 62:499-503.
 1962 *Structure and Sentiment: A Test Case in Social Anthropology*, Chicago and London.

- 1964a 'Descent, Category, and Alliance in Sirionó Society', *Southwestern Journal of Anthropology* 20:229-40.
- 1964b 'Explanatory Notes on Prescriptive Alliance and the Purum', *American Anthropologist* 66:1377-86.
- 1966a 'Terminology and Alliance: I. Garo, Manggarai', *Sociologus* 16:141-57.
- 1966b 'Comments on the Analysis of Purum Society', *American Anthropologist* 68:171-7.
- 1967 'Percussion and Transition', *Man* 2:606-14.
- 1968 'Translator's note', in: F. A. E. van Wouden, *Types of Social Structure in Eastern Indonesia*, The Hague, pp. XI-XIV.
- 1970 'Endeh, II: Test and Confirmation', *Bijdragen tot de Taal-, Land- en Volkenkunde* 126:246-58.
- Nooteboom, C.
- 1940 *Oost Soemba, een Volkenkundige Studie*, Verhandelingen van het Koninklijk Instituut voor de Taal-, Land- en Volkenkunde, deel 3, 's-Gravenhage.
- Nusa Tenggara Timur dalam Angka Tahun 1973, Kupang, 1974 (mimeographed).
- Onvlee, L.
- n.d. *Lessen Kambeaas (Oost Sumba)* (unpublished manuscript lent by the author).
- 1938 *Eenige opmerkingen bij de lijst van Soembaeische verwantschapsbenamingen* (unpublished manuscript lent by the author).
- 1949 'Naar aanleiding van de stuwdam in Mangili (Opmerkingen over de sociale structuur van Oost-Soemba)', *Bijdragen tot de Taal-, Land- en Volkenkunde* 105:445-59.
- 1973 *Cultuur als antwoord*, Verhandelingen van het Koninklijk Instituut voor Taal-, Land- en Volkenkunde, No. 66, 's-Gravenhage.
- Ossenbruggen, F. D. E. van
- 1918 'De oorsprong van het Javaansche begrip Montjpat in verband met primitieve classificaties', *Verslagen en Mededeelingen der Koninklijke Akademie van Wetenschappen* 5,3:6-44.
- 1930 'Verwantschaps- en huwelijksvormen in den Indischen Archipel', *Tijdschrift van het Aardrijkskundig Genootschap* 47:212-29.
- 1935 'Het oeconomisch-magisch element in Tobasche Verwantschapsverhoudingen', *Verslagen en Mededeelingen der Koninklijke Akademie van Wetenschappen*, Afdeling Letterkunde Deel 80, Serie B, No. 3, Amsterdam.
- Perry, W. J.
- 1914 'The Orientation of the Dead in Indonesia', *Journal of the Royal Anthropological Institute of Great Britain and Ireland* 44:281-94.
- Pos, W.
- 1901 'Soembaeische woordenlijst', *Bijdragen tot de Taal-, Land- en Volkenkunde* 53:184-284.
- Rivers, W. H. R.
- 1926 'The Primitive Conception of Death', *Psychology and Ethnology*, London.
- Rivière, P. G.
- 1971 'Marriage: A Reassessment', in: Rodney Needham (ed.), *Rethinking Kinship and Marriage*, A.S.A. Monographs 11, London.
- Roo van Alderwerelt, J. de
- 1890 'Eenige mededeelingen over Soemba', *Tijdschrift voor Indische Taal-*

- Land- en Volkenkunde* 33:565-95.
- 1891 'Soembaneesch-Hollandsche woordenlijst met een schets eener grammatika', *Tijdschrift voor Indische Taal-, Land- en Volkenkunde* 34:234-82.
- 1906 'Historische aantekeningen over Soemba', *Tijdschrift voor Indische Taal-, Land- en Volkenkunde* 48:185-316. (Offprint cited, pp. 1-131).
- Roos, S.
- 1872 'Bijdrage tot de kennis van taal, land en volk op het eiland Soemba', *Verhandelingen van het Bataviaasch Genootschap van Kunsten en Wetenschappen* 36:1-126.
- Ruibing, A. H.
- 1937 *Ethnologische studie betreffende de Indonesische Slavernij als maatschappelijke verschijnsel*, Zutphen.
- Schärer, H.
- 1963 *Ngaju Religion: The Conception of God among a South Borneo People* (trans. Rodney Needham), Translation Series 6, The Hague.
- Scholz, F.
- 1962 *Der Herr des Bodens in Ostindonesien* (Doctoral dissertation, Universität Köln, publisher not given).
- Schulte Nordholt, H. G.
- 1971 *The Political System of the Atoni of Timor*, *Verhandelingen van het Koninklijk Instituut voor Taal-, Land- en Volkenkunde*, No. 60, The Hague.
- Sell, H. J.
- 1955 *Der schlimme Tod bei den Völkern Indonesiens*, 's-Gravenhage.
- Singarimbun, M.
- 1975 *Kinship, Descent and Alliance among the Karo Batak*, Berkeley, Los Angeles, and London.
- Skeat, W. W. and Blagden, C. O.
- 1906 *The Pagan Races of the Malay Peninsula*, 2 vols., London.
- Suchtelen, B. C. C. M. M. van
- 1921 *Endeh (Flores)*, Mededeelingen van het Bureau voor de Bestuurszaken der Buitengewesten, bewerkt door het Encyclopaedisch Bureau, aflevering 26, Weltevreden.
- Swellengrebel, J. L.
- 1960 'Introduction', in: *Bali: Studies in Life, Thought, and Ritual* (trans. J. S. Holmes), The Hague and Bandung.
- Tambiah, S. J.
- 1973 'From Varna to Caste through Mixed Unions', in: J. Goody (ed.), *The Character of Kinship*, Cambridge.
- Tham Seong Chee
- 1977 *Language and Cognition — An Analysis of the Thought and Culture of the Malays*, Singapore.
- Tobing, Ph. L.
- 1956 *The Structure of the Toba-Batak Belief in the High God*, Amsterdam.
- Turner, V.
- 1967 'Colour Classification in Ndembu Ritual: A Problem in Primitive Classification', *The Forest of Symbols: Aspects of Ndembu Ritual*, Ithaca and London.

- Vergouwen, J. C.
 1964 *The Social Organisation and Customary Law of the Toba-Batak of Northern Sumatra* (trans. J. Scott-Kemball), Translation Series 7, The Hague.
- Verheijen, J. A. J.
 1951 *Het Hoogste Wezen bij de Manggariers*, Wien-Mödling.
 1967 *Kamus Manggarai, 1: Manggarai-Indonesia*, The Hague.
- Vroklage, B. A. G.
 1952 *Ethnographie der Belu in Zentral-Timor*, 3 vols., Leiden.
- Wetering, F. H. van de
 1926 'De Savoeneezen', *Bijdragen tot de Taal-, Land- en Volkenkunde* 82: 485-575.
- Wielenga, D. K.
 1909a *Schets van een Soembaneesche Spraakkunst (naar 't dialect van Kambera)*, Batavia.
 1909b 'Soemba: Slavenhandel', *De Macedoniër* 13:300-6.
 1909c 'Animisme en Spiritisme', *De Macedoniër* 13:332-40, 369-73.
 1910a 'Soemba: Offersteenen', *De Macedoniër* 14:72-80, 97-9.
 1910b 'Soemba: Boomen en verboden dingen', *De Macedoniër* 14:129-35, 201-6.
 1910c 'Tau Mamaroeng', *De Macedoniër* 14:235-42.
 1910d 'Soemba: in angst en vrezin', *De Macedoniër* 14:302-12.
 1910e 'Soemba: Schepping en Zondevlod', *De Macedoniër* 14:330-6.
 1912 'Fatalisme bij den Soembanees', *De Macedoniër* 16:206-13.
 1913 'Soembaneesche Verhalen. In 't dialect van Kambera, met vertalingen en aanteekeningen', *Bijdragen tot de Taal-, Land- en Volkenkunde* 68:1-290.
 1917 'Vergelijkende woordenlijst der verschillende dialecten op het eiland Soemba en eenige Soembaneesche spreekwijzen', *Verhandelingen van het Bataviaasch Genootschap van Kunsten en Wetenschappen* 61 (5e deel):1-96.
 1923 'Doodencultus op Soemba', *De Macedoniër* 27:297-310.
 1926a *Soemba*, Den Haag.
 1926b 'Zending en Polygamie', *De Macedoniër* 30:267-78.
 1931 'De Godsnaam op Soemba', *De Macedoniër* 35:14-20 (incorrectly attributed to D. Pol).
 1949 *De Zending op Soemba* (herzien en bijgewerkt door T. van Dijk en P. J. Luijendijk), Hoenderloo.
- Wilder, W.
 1964 'Confusion Versus Classification in the Study of Purum Society', *American Anthropologist* 66:1365-71.
- Wouden, F. A. E. van
 1956 'Locale groepen en dubbele afstamming in Kodi, West Sumba', *Bijdragen tot de Taal-, Land- en Volkenkunde* 112:204-46.
 1968 *Types of Social Structure in Eastern Indonesia* (trans. Rodney Needham), Translation Series 11, The Hague.

INDEX OF AUTHORS

- Abbott, J. 172n
Adams, M. J. 36n, 50n, 53, 250
Andree, R. 86n
- Barnes, R. H. 14n, 29, 32, 36, 59n, 66, 68, 68n, 87n, 114n, 124n, 126n, 127n, 129n, 143, 148n, 203n, 211, 211n, 212, 212n, 284n, 286, 287, 287n, 288, 288n, 292n, 293n, 294, 296n, 324n, 331, 337n, 354n, 355n, 369, 370n, 371, 371n, 398, 399, 400, 400n, 407n
Bateson, G. 21, 207n
Blust, R. A. 87n, 215n, 324
Bosch, F. D. K. 106n
Brandstetter, R. 87n
- Cassirer, E. 73n
Clamagirand, B. 38n, 131n, 279, 332n, 360n, 399, 400
Coomaraswamy, A. K. 69n, 236, 246n, 249n
Couvreur, A. 250
Covarrubias, M. 65
Cunningham, C. E. 35n, 65, 236, 241, 242n, 248, 261n, 281, 265n, 317n, 344n, 387n, 395n
- Dammerman, K. W. 92n
Dempwolff, O. 1n, 41n, 69n, 73n, 80n, 87n, 90n, 144, 167n, 179n, 219n, 221n, 237n, 311, 324, 324n
Dijk, W. van 39n, 40, 85n, 103n, 237n, 263n, 338
Dumézil, G. 236
Dumont, L. 406
Duyvendak, J. Ph. 151
- Echols, J. M. and Shadily, H. 155n
Endicott, K. M. 109n, 126, 126n, 127, 142n
Esser, J. 11, 229n
- Firth, R. 265n
Fischer, H. Th. 215, 216, 217n, 221n, 223, 290, 302, 309n, 315, 317, 323, 369, 372
Fischer, H. Th. and Renselaar, H. C. van 312n
Forth, G. L. 418n
Fox, J. J. 10, 14n, 18, 20n, 25n, 41n, 65, 88n, 116n, 167n, 183n, 215, 225, 236, 238n, 245, 288, 292n, 293n, 311n, 360, 416
- Gennep, A. van 133, 153, 160n, 162, 171, 189n, 195n, 379n, 380, 380n
Grijzen, H. J. 70n, 284n
- Heijden, A. J. van der 342n
Heijmering, G. 302n
Hertz, R. 171n, 177, 182, 187, 187n, 189n, 202, 206
Hicks, D. 163n, 215
Hocart, A. C. 236, 236n
Humme, H. C. 22n
- Jensen, A. E. 65
Jonker, J. C. G. 84n
- Kapita, Oe. H. 1n, 7n, 9, 11, 12n, 13, 15n, 17, 18n, 27, 27n, 28n, 30, 37, 41, 43, 53, 53n, 74n, 75, 80, 80n, 83n, 84n, 85n, 86, 87, 89n, 92n, 93n, 94n, 102n, 111n, 113n, 118, 131, 145, 152, 157, 157n, 159, 165, 176, 182n, 184n, 186n, 191n, 193n, 194n, 196, 198, 202n, 217, 217n, 222, 222n, 226n, 237, 245, 245n, 246, 250, 267, 268, 285, 285n, 286, 287, 287n, 289n, 292n, 295n, 310n, 311, 315, 342n, 344n, 348n, 352, 359n, 364n, 365n, 366, 366n, 367, 368n, 369n, 376n, 385, 387n, 390n
Kate, H. F. C. ten 52n

- Korn, F 421
 Kruyt, A. C. 15n, 73, 73n, 75, 98n, 124n, 126n, 148n, 163n, 165n, 167, 177n, 182n, 201, 215, 229, 238n, 330n, 335, 337, 339, 340n, 341, 344n, 350, 352n, 356n, 364, 364n, 370, 374, 385n, 397
- Lambooy, P. J. 83n, 87, 87n, 93, 93n, 94, 95n, 96, 103, 103n, 165n, 237, 237n, 248n, 324
- Leach, E. R. 159, 265, 274, 275, 275n, 279n, 338, 404n
- Lehman, F. K. 400, 404n, 409, 411n, 413
- Le Roux, C. C. F. M. 70n
- Lévi-Strauss, C. 301, 331, 368n
- Lévy-Bruhl, L. 73n, 133, 171n
- Needham, R. 143-4, 236, 266, 279n, 284n, 285n, 312n, 325, 331, 342, 397, 411, 414
- Nooteboom, C. 9, 39n, 77n, 223, 233n, 235, 366n, 411
- Onvlee, L. 17n, 18, 18n, 21, 35, 43, 66, 76n, 78n, 79n, 80n, 81, 90n, 102n, 126n, 134, 134n, 135, 135n, 137, 138, 138n, 139, 141, 142n, 144, 145, 148, 152, 153n, 159, 165n, 250, 257, 284n, 290, 290n, 292, 298n, 302, 315, 315n, 322n, 323n, 332, 360, 361n, 362, 363, 365n, 366, 366n, 368, 369n, 372, 374, 375, 375n, 378n, 381n, 382n, 383, 384, 384n, 386, 387n, 389, 391n, 400, 401, 415, 416n
- Ossenbruggen, F. D. E. van 241, 287, 290n, 351n, 359n, 369n
- Perry, W. J. 200
- Pos, 302n, 315
- Rivers, W. H. R. 171n
- Rivière, P. G. 375
- Roo van Alderwerelt, J. de 7, 7n, 8, 8n, 134, 199, 232n, 233n, 302n, 347n, 350, 361n, 374
- Roos, S. 8, 199, 220, 221, 223, 225, 226n, 229, 233n, 250, 253n, 260, 302n, 364, 370, 374, 377, 378, 380
- Ruibing, A. H. 215, 217n
- Schärer, H. 65, 200n, 230n
- Scholz, F. 249n
- Schulte Nordholt, H. G. 79n, 85, 85n, 106n, 114n, 131n, 236, 284n, 289n, 360n, 362n, 370n, 400
- Sell, H. J. 191n
- Singarimbun, M. 285n, 286n, 289n, 294, 330, 336n
- Skeat, W. W. and Blagden, C.O. 207n
- Suchtelen, B. C. C. M. M. van 65, 312n
- Swellengrebel, J. L. 65
- Tambiah, S. J. 234n
- Tham Seong Chee 69n
- Tobing, Ph. L. 80n, 85
- Turner, V. 209
- Vergouwen, J. C. 294, 295, 372n
- Verheijen, J. A. J. 84n, 85n, 87, 286
- Vroklage, B. A. G. 286
- Wetering, F. H. van de 102n
- Wielenga, D. K. 7n, 9n, 12, 13, 17n, 18, 21, 22n, 40, 52n, 74, 75, 75n, 79, 80n, 90n, 93n, 94n, 98n, 105n, 106n, 111, 112, 145, 146n, 152, 163, 164n, 167n, 215, 221, 234n, 237, 237n, 242, 245n, 250, 261n, 272, 315, 324, 324n, 341n
- Wilder, W. 279n
- Wouden, F. A. E. van 115n, 223, 236, 238, 241, 245, 248, 248n, 249, 249n, 284n

SUBJECT INDEX

- aboriginal population 110, 217, 238, 244n, 250
- abduction, marriage initiated by 389-90, 393
- abortion 13, 234, 336
- above/below opposition. *See* up/down opposition
- adjacent genealogical levels, relationship of 146, 148, 179, 326, 371, 419-21
- adoption 344
- adultery 142, 289, 293, 297, 299n, 336, 340, 348-51, 352, 356-8, 389n
- adults, adulthood 155, 156-7, 158-9, 165, 166, 168
- affines, affinity (*see also* wife-givers, wife-takers) 153n, 269, 275, 276, 281, 282-4, 317n, 341, 408, 418, 420, 421
- behaviours between 42, 295-301
- involvement in funeral 176, 180, 183-5, 275, 276, 341
- marriage with previous affines 390, 393, 396, 398, 400-05
- services provided by 291-5
- types of affines 283-4
- age, ageing 155-70, 261-3, 263-4
- age classes 155-7, 158
- funerary rites according to age 194-5
- relative age (*see also* elder/younger opposition) 155, 168, 169, 264
- agnation 259, 268-9, 275, 280, 280n, 282, 289, 290, 345, 406
- agricultural rites 81, 122-3, 133n, 151n, 168, 252, 276
- agriculture. *See* subsistence
- alliance 69, 130, 214, 219, 228, 234-5, 249, 273, 278-9, 282-301, 328, 333, 335, 341, 353, 372, 390-4, 417, 419, 420-1
- alliance and class standing (*see also* class, relation to marriage) 230-5
- alliance cycles 331, 371, 409-13
- alliance group 279-80, 291, 405-8, 414
- alliance prestations 153n, 165, 183-5, 187, 278-9, 284, 292, 329, 341, 350, 359-73, 387, 391, 416
- alliance relationship 228, 282-301
- patterns of 395, 400-5
- political aspect of 295, 404n
- altars 52, 70, 77, 81n, 82n, 118-28, 128-32, 133n, 160, 161, 162, 168, 260, 379
- agricultural altars 122-3, 357
- altar spirits 82n, 118-28, 128-32
- feast of the altars (*pamangu katoda*) 120-22, 357
- yard altar (*katoda kawindu*) 37n, 56, 87, 119-22, 139, 151, 153, 186, 204n, 261
- alternate genealogical levels, relationship of 94, 145-6, 148, 179, 300, 323-4, 326-7, 339, 419-21
- alternation, principle of 34, 87, 421
- Ana Kapu, clan 259, 268
- Ana Mawa, clan 246
- Ana Mburungu, clan (*see also* nobility) 10-12, 88n, 92, 100, 222, 223, 251, 254-7, 258-9, 265n, 266, 267, 268, 270, 271-3, 276, 279
- Ana Mburungu Kalindingu, clan 98, 267
- Ana Nggela, clan 266-7, 268
- ancestors 69, 70, 72, 77, 78, 87-103, 105, 110, 115, 118, 123, 125, 128-32, 139, 140, 141, 147, 151, 208n, 213, 227, 251, 253, 265, 266, 267, 269, 292, 357, 366, 376, 417-8, 420
- ancestral field 278
- ancestral namesake. *See* namesake ancestor
- ancestral relics 23, 89, 94-6, 126, 240, 244, 245n, 259, 260, 263, 269, 271-2, 275n, 366

- animals, domestic (*see also* buffalo; horse) 15, 41-2, 120, 278, 284, 285
 animals, wild 14-15, 50, 50n, 106
 Antares 85-6
 anti-clockwise direction 16, 28, 29, 30, 34, 172, 288, 380
 areca. *See* betel and areca
 ash 377, 377n, 382
 asymmetric (prescriptive) alliance (*see also* alliance) 1, 207, 282, 285, 289, 291, 299, 315, 317, 330, 371, 395, 400, 409, 411, 421
 asymmetry (*see also* unilaterality) 57, 416
 'atom of kinship' 301
 Atoni 35n, 65, 85, 85n, 106n, 114n, 131n, 241, 242n, 248, 261n, 265n, 281, 284n, 289n, 317n, 324n, 344n, 360n, 362n, 370n, 387n, 393n, 400
 augury 27n, 39, 75, 76, 139-40, 208, 292n, 357
 authority, division of 128, 236-64
 types of 97, 168-70, 214, 224, 236-64, 273
 within the clan 129, 261-3, 264
 within the village 260-1
 avoidance, relationship of 206, 298, 299n

 bachelorhood 333
 bad death. *See* hot death
 Bali 65, 118n
 banana 30n, 99, 137, 149, 160, 161, 162, 163, 164n, 166
 banyan trees 52, 78, 106, 106n, 224, 379
 base/head opposition. *See* head/tail opposition
 Base of the Sky 68-72, 89, 90, 91, 92, 93, 96, 97, 110, 111, 113, 129, 132, 140, 147n, 149, 200, 204, 205, 418, 420
 behavioural restrictions (between classes of relatives) 295-301
 Belu 286
 betel and areca 43, 74, 99, 134, 135n, 164, 165-6, 180, 212, 335n, 378
 betel container 74, 98, 102, 142, 166, 175, 181, 183, 186, 187, 193, 194, 196, 276, 360-1
 betrothal, of infants 334, 375, 387
 Bima, Bimanese 17n, 84n, 91n, 92n, 118n, 147n, 324n
 Bima-Sumba, group of languages 17n, 324

 biological classification 15n, 50
 biological paternity 343
 birth 133-54, 161, 162, 173, 201, 206n, 288, 418
 birthmarks 143
 black 16, 99, 108, 140, 143, 150, 164, 165, 168n, 190, 209, 210, 380
 blood 76, 109, 114, 133, 192, 289-90, 380, 410, 420
 body 29, 32, 73, 74, 87n, 155, 156, 307
 bone 29, 318
 boundaries 48, 97, 99, 111, 117, 118-28, 129, 146, 150, 153, 165n, 419
 breath 76, 134, 171
 bride service 383, 385, 386, 388, 390-1
 bride's substitute (*mamoha*) 198, 205, 220n, 228, 255n, 292, 376, 377-9, 379-81, 380n, 382
 bridewealth (*see also* alliance prestations) 38, 176, 187n, 221, 228, 229, 232, 233, 253, 278, 279n, 280, 293, 294, 296, 319n, 329, 332, 335, 338, 339, 340, 341, 341n, 342, 344, 346, 347, 359-73, 375, 377, 381, 383-4, 387, 388, 389, 390-1, 392-3, 393-4, 407
 buffalo 15, 30n, 92, 161, 182, 364, 369, 378, 379
 burial (*see also* funeral) 98, 179-83, 220
 joint burial, rules of 179-80
 temporary burial 178
 time of burial 176, 195

 cactus 46, 146, 149, 153, 191n, 286, 287
 cannibalism 110, 111, 111n, 114
 Cape sasar 10n, 91-2, 238
 cardinal points (*see also* orientation) 60, 65, 71
 caste system 234n
 Celebes 200
 centre 48-9, 53-4, 89, 117, 123, 123-4, 125, 126, 127, 129, 146, 166, 167, 240-1, 245, 246, 247, 255
 centre of the earth 89, 124
 centre/periphery opposition (*see also* inside/outside opposition) 40, 42, 48, 54, 123, 127-8, 240-1, 242, 255-6, 257-8, 416-7
 central conception of space 66
 Ceram 65, 249n
 ceremonial partners (*mbapa tunu; paratu*) 244, 259-60, 260, 268
 charms 107-8, 116
 childbirth. *See* birth

- childlessness 108, 167, 292, 294, 295, 338, 350-1, 352
- children, social standing of 155-6, 164, 165-6, 169-70, 218, 227
- Chin 404n, 409, 411n
- Christianity 9, 20, 87, 90n, 158
- 'circumcision' (*see also* initiation ceremony) 159, 164, 165, 166
- clan 45, 48, 88, 214, 216, 218, 237, 261n, 265-81, 395, 407-8, 423-5
- class system 168-9, 214-35, 236, 237, 249, 262, 263-4, 296, 322n, 401, 402n, 417n
- funerary practices according to class 195-9
- relation to marriage 214, 222, 227, 228, 230-235, 284, 295, 330, 337, 338, 362, 364, 370, 388, 394, 402-5, 411, 413
- clientship 217, 225, 228, 230, 387, 387n
- cloth goods (*see also* alliance prestations, counter-prestation) 16, 102, 165, 172-3, 181, 184, 201n, 222n, 275, 286, 369, 370n, 377n, 385
- clothing 16, 158n
- coconut 5, 76, 79, 160, 161, 163, 171, 175, 181, 182, 182n, 183, 221, 288n
- colours (*see also* black, green/blue, red, white) 108, 143, 143n, 207-10, 380
- comet 223
- commoners, class of 214, 216, 218, 227-30, 262
- compensatory payments. *See* fines
- complementarity 19, 59, 66n, 260, 318, 367, 375, 379, 415-6, 418
- complementary opposition 19, 415
- completeness (completion) 34-5, 91, 117, 134, 135, 157, 164, 211, 212, 259n, 345, 361, 361n, 416
- confinement (of mothers) 134, 141, 148-52, 153, 154, 177, 365
- contraception 13, 213
- cool (*see also* hot/cool opposition) 30n, 102, 125, 149, 151, 162, 163, 166, 419
- cool death. *See* death
- cool house. *See* house
- cool rain. *See* rain
- cool water, power, deity of 69, 98-100, 162, 165n, 193, 244, 258, 293, 352, 353, 355, 379
- cooling ceremonies 74, 98-100, 106n, 126, 148, 151, 162, 186, 283, 332, 349, 350, 352-3, 355, 379, 381, 410, 419
- corporations 234, 265, 270, 274-81, 342, 407
- corpse 108, 136, 146, 220n
- treatment of 171-9, 205-6, 291, 370, 380, 419
- cosmology 58, 66-72, 140, 224, 417-8
- counter-prestation (*see also* alliance prestations) 278, 279n, 294, 330, 334, 341, 359-60, 361, 362, 363-4, 366-8, 369-73, 377, 378
- crocodile 101, 101n, 108, 113, 193, 224
- crown (of hair, head) 73, 116, 157, 158, 159, 166-8, 181
- curing 102, 107, 115-6
- curse, cursing 114, 146, 294, 294n
- cycle (*see also* alliance cycles; life cycle) 71, 92-4, 194, 201, 202-3, 205, 207, 312, 409, 418-20
- cyclicity 69, 77, 93, 146, 418-9
- Dai Ndipi, clan 11, 12, 101-2, 251, 253, 403, 408
- dark/light opposition (*see also* black; white) 135
- dead, souls of 71, 72, 92, 93, 131, 159, 292, 377n
- death (*see also* burial; funeral; life/death opposition) 70, 71-2, 73, 165, 171-213, 349-50, 352, 354, 418
- cool death 191
- hot death 114, 191-3
- demography. *See* Rindi; Sumba: population
- demons (*see also* earth spirits; giants) 105-6, 111
- descent (*see also* agnation) 214, 230, 232, 235, 238, 249, 261, 262, 263-4, 265, 288, 289-91, 420, 421
- descent groups (*see also* clan; lineage) 265-81, 423-5
- direct exchange 279, 279n, 395, 396, 396-7, 398, 406, 407, 411
- direction, terms of (*see also* orientation) 58-66
- divination. *See* augury
- divinity (*see also* altar spirits, ancestors, God) 73, 78, 82, 83-103, 112, 118, 119, 126, 127, 129-30, 132, 140, 169, 240, 256, 417, 418
- divorce 340-2, 375
- domain 45-6, 236, 249, 257, 265, 266, 267, 275, 280
- Donggo 87
- dreams, dreaming 74, 105, 106, 107, 110, 135
- dry season 5, 86, 87, 110, 111, 160, 418

- dual leadership 236-64
 in Rindi 255-60
- dualism 19, 35, 59, 175, 230, 415, 416-7, 419
- Dutch 20, 46, 216, 222, 233, 243, 254, 271
 colonial administration 7, 12, 46
 Dutch Calvinist Church 9
 Dutch East India Company 7, 11
- earth (*see also* Head of the Earth) 45, 70n, 104-32, 192, 192n, 352, 356, 357
 centre of the earth. *See* centre
 earth/sky opposition 67, 68, 73, 87, 90, 104, 131, 132, 248-9, 354, 417
 earth spirits 79, 104-32, 146, 192, 245
 earth tremors 124
- East Sumba regency 1n, 9, 13, 17
- eclipse 223
- egg 107, 109, 121, 137, 137n, 143, 143n, 189, 192, 194-5
- eight 34, 35, 90, 117, 121, 126, 134, 149, 153, 157, 160, 176, 186, 189, 190, 196, 210-1, 212-3, 247, 378, 416
- elders (*see also* priest) 156, 169, 170, 237, 261
- elder (older)/younger opposition 44, 95, 128-9, 130-1, 169n, 218, 218n, 232, 238-40, 242, 248n, 249, 264, 273, 274, 274n, 308, 315, 321-2, 326, 365
- elopement 278n, 333, 334, 335, 376, 388-9, 393
- Ema 38n, 131n, 279, 332n, 360n, 399, 400, 400n, 403, 404
- Ende, Endenese 7-8, 9, 10, 14, 65, 90, 108, 147n, 150, 312n
- estuary. *See* river mouth
- even numbers (*see also* eight; four; odd/even opposition; sixteen) 34-6, 134, 160, 178, 182, 204n, 210-3, 361-2, 416
- evening star 85n
- exogamy 265, 265n, 268, 280, 345, 346, 408, 414
- feast of souls ceremony (*langu paraingu*) 81, 377n, 378
- feces 377, 380, 382
- fertility 52, 55, 69, 77, 80, 85, 87, 119, 120, 129, 159, 160, 167, 240, 289, 355, 356, 360, 379, 379n, 410
- fetus 114, 138, 139, 201
- fields (*see also* land tenure) 6, 7, 47, 57, 230, 274
- fieldwork, conditions of 20-2
- finis 101, 102, 252, 285, 293, 297, 341, 349, 351, 352, 353, 354
- fire 112, 165
- first fruits ceremony (*ngangu uhu*) 81, 85, 166, 167, 252, 278, 292n
- flood (*mulungu*) 49, 90, 140
- Flores 7, 92n, 150, 286
- fontanelle 30, 157, 167, 288n
- food cravings 134-5
- food prohibitions 101, 102, 107-8, 268
 during pregnancy 137, 148
- forehead 73, 107, 115, 157, 158-9
- forelock 157, 158, 159, 167n
- fosterage 344, 386
- four 27, 34-5, 46n, 89, 121, 126, 143, 147, 151, 157, 160, 173, 176, 186, 204, 205, 210, 211, 212, 245, 247, 345, 355, 377, 378, 379, 416
 four-five pattern 124, 241, 258, 416-7
- front/back opposition 27, 37, 39, 41, 42, 152, 190, 376
- funeral 171-213, 280, 285-6
 final ceremony (*pahili mbola*) 184n, 185, 186, 189-90, 193, 197, 199, 204n, 205, 210, 276
 funerary prestations 165, 183-5, 275, 339, 349, 354, 387, 391, 406n
 special funerary attendants (*papang-gangu*) 184n, 196, 197-9, 219-20, 266
- gates 52, 54-5, 120, 121, 121n, 124, 207n
- genealogical level 81, 289n, 299, 300, 301, 315n, 338
- genealogies 272, 395, 403, 422
 knowledge of 346, 395, 413
- generations, relations between (*see also* adjacent and alternate genealogical levels; genealogical level) 170
- genitalia 69, 140, 143, 160-1, 297, 354n, 360, 366, 418
- giants 79, 111-3
- God 75, 77, 78n, 82, 83-7, 88, 89, 90, 91, 92, 94, 96-8, 110, 111, 119, 123, 125, 127, 139, 143, 145, 191, 203, 226, 241, 244, 266, 294, 420
- gold (*see also* metal; metal goods) 16, 79, 85, 117, 125-6, 172, 208, 227n, 353, 363
- gongs 16, 144, 153, 176n, 196, 199, 267, 378, 379
- graves 47, 50, 55, 56-7, 63n, 67, 71, 180, 180n, 220n
- grave goods 172, 184, 187, 349, 354, 369

- green/blue 115-6, 208, 209
guardian spirit (*see also* altar spirits) 78-9
guests, treatment of 42
- hair (*see also* crown of hair; forelock) 73, 112, 114, 150, 157-9, 166-7, 172, 181, 182, 291, 292, 308
cutting of 150, 152, 153, 157-9, 166-8, 291, 292
hairstyles 156, 157-9
pubic hair 112, 167
hamlets. *See* village
head 167, 223
human head 73, 111, 167
Head of the Earth 67-72, 87, 89, 92, 110, 111, 116, 128n, 129, 132, 140, 149, 200, 204, 205, 207, 223, 287n, 418, 420
head of the island 61-3, 64, 67, 70n, 72, 223
head of the river 66, 69, 120, 354
head/tail opposition (*see also* front/back opposition) 41, 53-4, 55, 61-3, 65, 66-72, 190, 242
headman (of clan) 156-7, 259, 261-3, 278, 278n, 388
heart (*see also* navel) 53, 89, 170
hearth 27, 28, 30n, 38, 141, 147, 150, 151, 153, 382
heaven. *See* sky
heavenly bodies (*see also* moon; morning star; sun) 61, 85-6, 223-4, 227
heavy/light opposition 97, 129, 148, 169, 194n
high/low opposition. *See* up/down opposition
Hindu 69n, 172n, 236, 246n, 249n
horizon (*see also* Base of the Sky) 68, 68n, 91, 204
horse (*see also* alliance prestations; bride-wealth) 8-9, 15, 61, 95, 120, 167n, 175, 180, 181, 182, 359, 360, 361, 364, 367, 369
hot 111, 113, 114, 142, 147n, 151, 151n, 161, 162, 186, 191n, 198, 351, 353, 356, 357
hot and cool land, earth 104-5, 106, 109, 123, 130, 252, 419
hot/cool opposition 24, 42-3, 48, 50, 55, 69-70, 95-6, 98-9, 104-5, 120, 121, 123, 130, 131, 149n, 162, 186-7, 186n, 191, 203, 357, 358, 419
hot death. *See* death
- house 23-44, 102, 123-5, 270, 281, 285n, 286, 294, 353, 357, 416, 421
ancestral house 23-4, 48-9, 84n, 97n, 124, 126, 172, 255, 262, 269, 272, 273, 275, 276, 378
cool house 24, 43, 47, 48, 272, 274, 294
house peak 23, 28-9, 37, 39n, 48, 94, 95, 96, 167, 205, 366
house posts 27-8, 35n, 38, 39n, 94, 123, 124, 141, 173, 256n, 288
mortuary house (*kawarungu*) 196-7, 198, 199, 293, 294
ndewa house (Uma Ndewa) 39n, 81, 82, 255-6, 259
orientation of houses 55-7, 63, 67
skull post house 54, 100, 267n, 271
spirits of the house. *See* spirit
types of houses 23-4
Humba (*see also* Sumba) 3, 4, 17
- Iatmul 207n
illegitimacy 336, 342
illness 74, 88, 100, 102, 105, 107, 110, 111, 114, 115-6, 120, 122, 137, 141n, 148, 152, 169, 288, 292, 352
incest 35n, 70n, 85, 86-7, 99, 137n, 142, 159n, 179, 336, 348-9, 350, 351-6, 356-8
incorporation 265, 342-5, 346, 368, 375, 377, 381
rites of 144, 152-3, 153-4, 162, 377, 380-1
India 106n, 222n, 234n
indigo 86, 86n, 136
Indonesian (Bahasa Indonesia) 10, 17, 17n, 21, 53n, 63n, 64, 75n, 80n, 82, 155n, 237n, 249, 266, 282n, 309, 348n, 359
Indonesian government 10, 13-14, 17, 20, 216, 225, 334n, 335, 389
Indonesian languages 17n, 87, 287, 311, 348
inheritance 232-3, 269, 277, 278, 344
of names 144
initiation ceremony 154, 159-63, 177, 179, 202, 206n
inside/outside opposition 37, 40, 41-3, 48, 81, 82, 104-5, 110, 115, 120, 128-32, 142, 191, 193n, 220, 224-5, 240, 248, 274n, 336, 354, 356-8, 360, 361, 391-2, 419
inversion (*see also* alternation) 42n, 67, 116, 162, 172, 175, 179, 181, 181n, 190, 191, 199, 200-1, 206, 283, 348, 409, 410, 418

- iron 126, 126n, 142n, 361
 Islam 9, 20, 87, 90n, 108
 ivory 16, 359, 359n, 362
- Java, Javanese 7, 64n, 84n, 147n, 222n
 joint (*see also* knot) 126n, 165n, 167, 315n
 joking 300
- Kaburu, clan 257-9
 Kachin 338, 404n
 Kadumbulu, clan 246, 267n
 Kahiku, clan 268, 268n
 Kaliti, clan 10-11, 223
 Kambaniru, river 10n, 80, 91, 204, 205n
 Kambara, district 10, 80, 229, 239n, 265n, 268, 307n, 309n, 324n, 356n, 364
 Kambara, language 17, 63, 79, 111, 167n, 302n, 315
 Kanatangu, clan 101, 150n, 267, 406, 406n
 Kanatangu, district 143n, 239, 246, 344n, 383n
 Kanilu, clan 11, 88
 Kapunduku, district 52n, 53, 67n, 250, 344n
 Karambu, clan 11, 46n, 193n
 Karera, district 11, 12, 90
 Karindingu, clan 10-11, 259, 268, 295
 Karo (Batak) 285n, 286n, 289n, 330, 336n
 Katinahu, clan 11-12, 257-9, 269, 343, 406
 Kédang 28, 35, 36, 59n, 66, 68n, 85n, 87n, 114n, 124n, 126n, 127n, 129n, 143, 148n, 203n, 211, 212, 286, 287, 288, 296n, 331, 337n, 354n, 355n, 370n, 371, 371n, 398, 399, 400, 407n
 Kihi, clan 101n, 257, 258, 259
 knot (*see also* joint) 28, 157, 158, 167, 168, 173, 181, 289n, 369n, 376n
 Kodi, district 115n, 290n, 307n, 311, 324n
 Kurungu, clan 102
- ladder 31, 98, 173, 204, 205, 212
 Lamuru, clan 9n, 11, 238, 268
 land. *See* earth; fields
 hot and cool land. *See* hot
 land tenure (*see also* 'owner of the land') 228, 251-2, 277-8, 367
 land of the dead 71, 74, 77, 93, 165, 181, 187, 189, 190, 193, 194-5, 199-200, 202, 203, 204, 205n, 207
- language (*see also* Indonesian; Kambara) 3, 17-20
 ritual language 18-20, 80, 141n, 376, 416
 laterality (*see also* right/left opposition) 58, 59-60, 66, 200, 201
 left (*see also* movement to the left; right/left opposition) 108, 116, 131, 173, 181, 186, 193, 194
 left-handedness 116, 135n, 186
 length/width opposition 62
 Lewa, district 12, 295n, 364n, 397
 life, sources of. *See* source
 life cycle (*see also* birth; death) 73, 133, 155-70
 life cycle rites 85, 120, 159-63, 166-8, 210, 276, 345, 380
 life/death opposition 81, 82, 136, 146, 177, 186n, 202, 220, 358, 418, 419, 420, 421
 life force 76-7, 78, 82, 337, 349, 350n
 light (*see also* heavy/light opposition) 138, 148
 lightning, death by 101, 193
 lime 17, 86, 252
 line (*see also* descent groups; lineage) 271, 406
 lineage 222, 254-7, 266, 395
 named lineages 166n, 216, 254-7, 254n, 264, 270-4, 275, 276, 277-8, 279, 280, 346, 395, 407, 410
 lineal seniority 168, 169, 227, 232-3, 263-4, 272-3, 273
 liver 75, 89, 170
 livestock, ownership of (*see also* animals, domestic; buffalo; horse) 278
 'lord of the land' (*see also* 'owner of the land') 249, 249n
 lords of the earth (*see also* earth spirits) 105-9, 112, 113, 118, 130, 131, 224
 Luku Tana, clan 46n, 245n
 Luku Walu, clan 268
- Madjapahit 7, 222n
 Mahora, clan 12, 197n, 257-9, 269, 270, 271, 273, 274, 279, 403, 408
 Mahu, district 5, 14, 17, 204, 233, 364
 maize 14n, 14-5, 87, 122, 137, 147, 160, 176n
 Makassar 118n, 147n
 Malays 69n, 109n, 126, 126n, 142n
 male/female opposition. *See* masculine/feminine opposition
 Mamboru, district 124n, 290n

- Mamburu, clan** 246
Manggarai 17n, 64n, 84n, 85n, 87, 284n, 285n, 286, 329n, 391n
Mangili, district 7, 11, 12, 14, 17, 62, 90n, 134n, 233, 250, 251, 257, 284n, 295, 311, 356n, 362, 369n, 408
Mantra 207n
Marada Witu, clan 259, 268
Marapeti, clan 237, 243-4, 250, 252, 260
Maritu, clan 233, 259, 268
marriage (*see also* alliance) 130, 154, 158, 160, 164, 166n, 185, 205, 208, 212, 221, 229, 265, 270, 274, 278, 280, 283-4, 328-47, 374-94, 418
 forced marriage 334-5, 376, 389
 informal marriage (*patidungu*) 335, 339, 343
 'marriage by entry' (*lalei tama*) 342, 368, 387
 rules of marriage 328-333, 370, 414
 degree of conformity to 395-408, 413-4
masculine/feminine opposition 35, 37-44, 54-5, 68-9, 70n, 80n, 83-4, 87, 92-3, 95, 104, 108, 116, 128, 135, 135n, 140, 143n, 144, 147, 149, 152, 158, 159, 172, 195, 205-6, 209, 213n, 235, 248, 284-5, 284n, 300, 359-62, 363, 365n, 369, 380-1, 415-6, 417, 419
massage 134, 142, 142n
Matalu, clan 246, 343, 344n
matriliny 115n, 235
maturity 143, 154, 158, 159, 163, 166, 168
Mbara Papa, clan 259, 268
Mbata Kapidu, district 324n
Mburu Pala, clan 259, 268, 268n
Mbuu, clan 247
medicine (*see also* curing) 106, 116, 134
media 94, 96, 99, 100, 123, 126, 127, 131
mediation 88-9, 92, 96-7, 99-100, 118, 169, 209, 376
Melolo 9, 10, 11n, 17, 182n
Menggitu, clan 112n, 247n, 257n
menstruation 133-4, 208, 300
metal (*see also* ancestral relics; gold; iron; silver) 85, 94-6, 99, 100, 125-7, 227, 368-9, 369n
metal goods 8, 16, 94, 95, 99, 102, 142, 172, 173, 187, 222, 251, 278, 292, 359, 361, 364, 368, 369
Milky Way 61n, 193
miscarriage 138
month, lunar (*see also* moon) 111, 133, 208, 222n, 419
moon 85, 90, 106, 116-7, 144, 194, 208, 222, 223
morning star 85, 160, 161, 167, 355
mortuary house (*kawarungu*). *See under* house
mother's brother 69n, 223, 287-8, 291, 294, 294n, 331, 334, 365, 375, 377, 385, 388, 388-9
mother's brother's clan, marriage with 231-2, 288-9, 328, 329, 398-9, 404-5
mother's brother's daughter, marriage with 231, 329-30, 398-400, 405, 413
mourning 175, 180
 end of mourning ceremony 185-7, 188, 189, 196, 199, 419
mourning terms 324-5, 420n
movement to the left 34, 172, 173, 196, 199, 200-1, 207, 357, 418, 421
movement to the right 28, 30, 34, 35, 108, 200, 201, 206, 288, 358, 417, 418, 421
Muru Uma, clan 237, 240n, 241, 243-4
myth 86, 89, 113, 222, 237-9, 243, 244n, 245, 246-7, 258
 clan myths 86-7, 89, 98, 101, 113, 294n
 creation myths 89-93
nails 114, 143
nakedness 107, 115, 115n, 156
names 75, 79, 94, 144-6, 165, 195, 219, 219n, 226, 226n, 322, 323, 327, 419
 clan names 266-7
 place names 49
name-giving ceremony 144-6, 152, 154
namesake ancestor 75, 79, 85, 144, 145, 146, 147, 151, 226, 323, 377, 420
Nàpu, district 36n, 47n, 52n, 53, 295n, 411
natural species, as clan patrons 100-3
navel 53, 144, 145, 150
navel cord. *See* umbilical cord
Ndembu 209
Ngaju 64n, 65, 163n, 200n, 230n
nobility, noble class (*see also* Ana Mburungu) 72, 80, 81-2, 160, 162, 166n, 214, 216, 221-7, 232, 248, 257, 264, 276-8, 285n, 292, 293, 322, 335, 344, 363, 376, 403, 411
 funerals of 171, 172, 176, 177, 180, 181n, 182, 188, 193n, 195-9, 229, 276
 marriages of 229, 232, 249, 403, 404,

- 407, 411, 413
 noble rulers 84, 222, 225-6, 237-49, 250, 254-7, 271, 390, 422
 special supporters of nobility (*tulaku paraingu*) 247, 257-60
 types of nobility 221-2, 272
 numbers (*see also* even numbers) 34-6, 117, 121, 210-3, 380, 416-7
- oath 299n
 odd/even opposition 35-6, 91, 117, 135, 135n, 138, 210-3, 417
 odd numbers. *See* odd/even opposition
 Ongga, clan 237, 243-5, 248
 orientation 55-7, 58-66, 70, 141, 177, 200, 288
 orifices 113
 origin (*see also* source; trunk) 68, 69, 72, 118, 119, 166, 201, 223, 286, 288, 289, 417, 418
 origin of death 92-3
 origin of incest 86-7
 origin of the nobility 72, 222-4, 248
 origin of the slave class 217-8
 orphans 112, 130n, 333, 344
 orthography 17-18
 'owner of the land' (*mangu tanangu*) 238, 245, 248, 249-53, 261
- Pahada, clan 90
 Pakilungu, clan 101n, 247n, 250
 Palai Malamba, clan 10, 11, 223, 237-9, 242-3, 245n, 246-7, 254, 260, 273, 279n, 295, 344n
 Palamidu, clan 10, 247, 247n, 250
 Parai Yawangu 11-2, 14, 20, 46, 49, 51, 54, 78, 251, 255-7
 Paraina Bakalu, clan 244, 247
 parallelism 18, 59, 219
 partner, counterpart (*papa*) (*see also* ceremonial partners) 19, 59-60, 66, 160, 197, 309, 367, 375, 379, 416
 Patawangu, district 9n, 11, 13, 238
 patriliney (*see also* descent; inheritance; succession) 69, 88, 130, 387n
 patrilocality 274
 Penan 325
 percussion 143-4, 199, 378, 379
 phonology 18
 placenta 143, 147, 151, 195
 plant metaphors 194
 planting 14-5, 32, 179n, 208
 Pleiades 85-6
 polygyny 232n, 272, 331, 336-8, 342
 Portuguese 7
 Pramalai Kallar 406
 preference 231-2, 284, 329-30, 370, 398-9, 405
 pregnancy 132-8, 140, 177, 208
 prescription 234, 282, 288, 312, 328, 329, 396, 398
 prescribed category 142, 282, 329
 prescribed spouses, relationship of 142, 300, 336n
 prescriptive alliance (*see also* asymmetric alliance) 282, 302, 342
 priest 19, 156-7, 169, 170, 178, 179, 220, 236n, 237, 260n, 262-3
 primogeniture 232, 233
 privileged union 331
 Purum 331
- quadripartition (*see also* four) 46n, 217, 244, 267, 268n
- radiance 76, 78, 79, 85, 106n, 115, 127
 rain 5, 69, 202, 203, 342n
 cool rain 69, 121, 203
 rainy season. *See* wet season
- Ramba, clan 98
 rank. *See* class system
 raw food, as offering 109, 115, 117, 121n, 192
 raw/cooked opposition 109, 121n, 391n
 red 108, 115, 133, 134, 139, 147, 156, 166n, 171, 172, 173, 180, 181, 189, 194, 206, 207-9, 363, 377, 379
 reflexion 74, 140, 365, 375, 385n
 relationship terminology 219, 282, 285, 286, 302-27, 409, 414, 414n, 421
 religious leaders (*ratu*) 11, 105n, 237-49, 250, 251, 254, 255, 256, 259, 260, 264
 renewal, rites of 120-2, 133n, 168, 240, 241, 256
 residence, post-marital (*see also* patrilocality; uxorilocality) 274-5, 383, 390-1, 392-3
 restriction, annual period of 110, 124n, 155n, 211n, 418-9
 restrictions during mourning 176-9, 186
 restrictions during pregnancy 32, 135-8
 rice 14-5, 85, 87, 100, 122-3, 138n, 167-8, 229, 277-8
 right (*see also* movement to the right) 160
 right/left opposition 37-9, 42, 55, 59, 60,

- 65, 108, 135, 135n, 143n, 147, 149, 172, 175, 181, 190, 195, 200-1, 205, 206, 285n, 358, 377-8, 380-1
- Rindi, clan 5, 11, 101n, 251, 252n, 267n
- Rindi, district
- administrative status 12-3, 13-4
 - economy 14-7
 - history 10-3
 - language 17-20
 - name 5
 - physical setting 5-7
 - population, distribution and size 7, 13-4
- ritual conflict 180-1, 377, 378, 380, 382
- ritual language. *See* language
- ritual privileges (*mangapangu*) 161n, 198-9, 252, 292
- ritual speakers 19, 169, 183, 185, 220, 229, 258, 296, 341, 366, 376, 381
- river(s) 5, 46, 52, 62, 63, 66, 67, 70n, 149, 150, 151, 160, 162, 202, 203, 356
- river mouth 63, 66-7, 69-70, 70n, 120, 122, 181, 203, 204, 252n
- Roti, Rotinese 14n, 20n, 25n, 61n, 65, 67n, 88n, 116n, 167n, 183n, 215, 225, 238n, 249n, 288, 293n, 311n, 324n, 360
- rulers. *See* nobility, noble rulers
- salt 17, 112, 143n, 252
- Sanskrit 77, 79n, 369n
- Savu, Savunese 9-10, 14, 15, 17n, 20n, 90, 102n, 182n, 251, 324n
- schools 12, 135, 158
- Scorpius 61, 86n
- sea 60, 63, 69-70, 111, 113, 203, 224, 356n
- male sea/female sea 70n
- segmentation 97, 269-74, 275, 279, 279n
- semen 90n, 134, 136, 208, 342n
- separation, rites of 145, 153-4, 162, 179, 190, 379, 380, 382
- separation of spouses (*see also* divorce) 340-1, 349
- Seram. *See* Ceram
- seriality 137
- settlement pattern 5, 7, 45-9, 274
- sexual intercourse 134, 136-7, 160, 162, 356, 357
- sexual transgression (*see also* adultery; incest) 115n, 137, 161, 162, 348-58
- shadow 72-3
- shame 159, 311
- shrine (*pahomba*) 79-82, 118-9, 131-2, 204, 250n
- silver (*see also* metal; metal goods) 117, 125, 126, 134, 208, 353, 363
- sinew 27n, 29, 29n, 76, 124, 125
- Sirionó 414
- sister's son, child 288, 291, 311, 329, 344
- sixteen 196, 210-1, 247, 378
- skull post 54, 54n, 100, 271
- skull post house. *See under* house
- sky (*see also* Base of the Sky; earth/sky opposition) 85, 89, 222, 223, 224
- slaves, slave class 197, 214, 215-21, 225, 226, 228, 230, 242, 245, 255, 277n, 278, 292, 292n, 309, 322, 368, 426
- alliance among 413-4
 - debt slavery 217n
 - killing of slaves 182, 221
 - marriage among 216, 345-7, 368, 395
 - ritual functions of slaves 197, 219-20
 - slave trade 7, 8, 9, 215, 216, 221, 369, 372
 - types of slaves 215-6, 219-21
- smell 106, 150, 171, 176, 177, 186, 410n
- snakes 106, 106n, 107, 113
- soul 73-82, 94, 102, 108, 109, 112, 114, 133, 137, 137n, 138, 143, 145, 151, 152, 166-7, 181, 187, 187-8, 194n, 203, 292, 294, 350, 354, 380
- journey of the soul 203-5
- source (*see also* origin; trunk) 41n, 68, 69, 70, 104, 132, 167, 201, 223, 241, 255, 286, 286n, 287, 287n, 289, 350, 354, 366, 417, 418, 419, 420
- sources of life 77, 104, 129, 287-9, 293
- sources of rivers (*see also* Head of the Earth; head of the river) 67, 69, 287n
- space (*see also* orientation) 58-72
- spindle 138n, 149-50, 151, 153, 154
- spinsterhood 219, 333
- spirit (*see also* altar spirits; divinity; earth spirits; guardian spirit) 70, 73-82, 133, 151, 203, 409
- spirit of the crop 82n, 122, 123, 202
 - spirit of livestock 120
 - spirits of the house 123-5, 240-1
- spiritual/temporal opposition 37, 39, 40, 44, 47, 48, 54, 169, 214, 224-5, 231, 236-64, 273, 293, 327n, 419
- stars. *See* heavenly bodies
- stillbirth 138, 143, 194, 195
- subsistence 14-7, 273, 277-8
- succession 129, 232-3, 240, 344
- suicide 22n, 191, 335

- Sumba
 climate 5
 history 7-10
 languages 3, 17-20
 location 5n
 name 3-4
 physical geography 3-5
 population, distribution and size 5, 8, 13
 sun 55-6, 60-1, 65, 68, 70, 85, 90, 200, 222, 223, 354n
 rising sun, sunrise 55, 56, 141, 160, 166, 223
 rising/setting sun opposition 55-6, 60, 62-3, 68, 71-2, 200
 setting sun, sunset 55, 56, 179, 180, 196, 200
 sweating 134n, 138, 148
 symmetry 57, 411
- Tabundungu, district 5, 10, 204, 223, 224, 248n, 254, 267n, 295, 352n
 tail (*see also* head/tail opposition) 242
 tail of the island 61-3, 64, 72, 224
 Tarimbangu, clan 267
 tattooing 163, 165
 teeth 111, 115, 156, 157, 163, 164-5
 teeth blackening 163, 164-5
 teeth filing 163-4, 165
 Tetum 163n, 215
 Tidahu, clan 46n, 267n, 343
 tides 144
 time 69, 87, 418-9
 time of birth, determination of 143
 Timor 165n, 241, 248, 284n
 Toba Batak 80n, 290n, 295, 312n, 369n, 372n
 traditional narrative (*see also* myth) 69n, 111, 112, 127, 130
 trance 198, 298n
 transgression (*see also* sexual transgression) 142, 169, 191, 192
 transformation 203, 419
 transition (*see also* boundaries; mediation) 29, 92, 94, 111, 116-7, 124, 124n, 125, 126-7, 132, 134, 143, 153-4, 161, 162, 166n, 177, 181, 187, 196, 198, 208, 209, 211-2, 213, 236n, 294, 325, 377n, 380, 382, 419
 tripartite classification 215, 417n
 trunk (*see also* origin; source) 24, 44, 69n, 72, 77, 94, 149, 167, 223, 262, 311, 332, 365, 366, 417
 trunk/tip opposition 33-4, 44, 201, 252n, 286-9, 290, 348, 409, 417, 421
 twins 137, 137n, 179, 337, 371
- Uma Kambata, lineage 222, 271n
 Uma Paterangu, clan 46n, 266
 Umalulu, district 3, 4-5, 10, 12, 13, 14, 17, 46, 53, 64, 80, 143, 207n, 215, 223, 236, 237-49, 250, 251, 252, 254, 255, 256, 259, 270, 273, 311, 344n, 408, 417
 umbilical cord 101, 136, 142-3, 144, 145n, 149, 150, 153, 195
 unilaterality 231, 279, 280, 282, 288, 289, 292, 299, 395, 398, 407, 414, 417, 418
 up/down (= above/below, high/low) opposition 37, 40, 41, 43, 47, 58, 60-3, 71, 95, 104, 128, 140, 158, 223, 249, 367
 upstream/downstream opposition 52-5, 57, 58, 59, 60, 62, 65, 69, 70, 71, 149, 181, 190, 202, 203, 207n, 224, 242, 247, 256, 356
 uxoriality 265n, 274, 294, 367, 381, 383, 386, 390, 392
- vertical/horizontal opposition 124, 130-1, 242
 village 45-57, 70, 78, 119, 124, 270, 274, 275, 417
 corporate aspects of 280-1
 chief village (*see also* Parai Yawangu) 8, 45-8, 225, 230, 240-3, 255-7
 spatial arrangement of the village 50-7
 subsidiary villages 46-9
 types of villages 46-9
 village of the dead. *See* land of the dead
 Venus (*see also* morning star) 85n
- Wai Jilu, district 10, 11, 17, 61, 62, 63, 70n, 222, 223, 239, 239n, 295n
 Wailolong 284n, 288n, 331
 Waingapu 8, 20, 61, 370n
 Wanga, clan 12, 181n
 war 7-8, 10-11, 12, 46, 216, 217, 221, 225, 242, 244, 265n, 271, 356n
 war captives 216, 217, 221
 war ritual 54, 137n, 271n
 warriors 137n, 257n
 warming, of new mothers (*see also* confinement) 148-9, 161, 177
 Watu Pelitu, clan 237, 239, 242-3, 245n, 246-7
 Watu Waya, clan 5, 237-8, 241-4, 246, 254

- wealth (*see also* bridewealth) 8, 78, 119, 127, 167n, 182, 225-6, 226-7, 230, 232, 234, 242, 243, 287, 333, 362, 369, 393, 394
 weaning 152
 weaving 16, 19, 136, 176-7, 361, 369
 West Sumba regency 13n, 17n, 62
 western Sumba 3, 3n, 9, 17n, 20, 39n, 40, 62, 62n, 67, 74n, 85n, 88, 102n, 215, 224, 237n, 238n, 249n, 263n, 265, 290n, 307n, 311, 322n, 324, 324n, 359n, 397
 wet season 5, 86, 87, 110, 111, 121, 203, 418-9
 whale 49, 224
 white 111, 115, 143, 150, 164, 165, 194, 208, 209, 210, 363
 widows 175, 175n, 309n
 widow-inheritance 336, 337, 337n, 338-40, 342
 widowers 309n
 wife-givers (*see also* affines; alliance relationship) 69n, 70, 77, 101, 129, 207, 223, 224, 239, 253, 258, 278, 282, 284-9, 292-5, 295-6, 297, 300, 314, 317, 326, 349, 376-7, 389n, 394, 421
 wife-takers (*see also* affines; alliance relationship) 150, 181, 207, 218, 253, 282, 284-9, 291-2, 292n, 296, 297, 317, 329n, 344, 376-7, 382
 Wiki, clan 265n
 wind 63n, 110
 witch 70, 74, 107, 109, 109n, 110, 113-7, 120, 126n, 131, 145, 146, 159, 164, 178, 192, 193, 221, 225, 244, 245n, 333
 year 155, 418-9

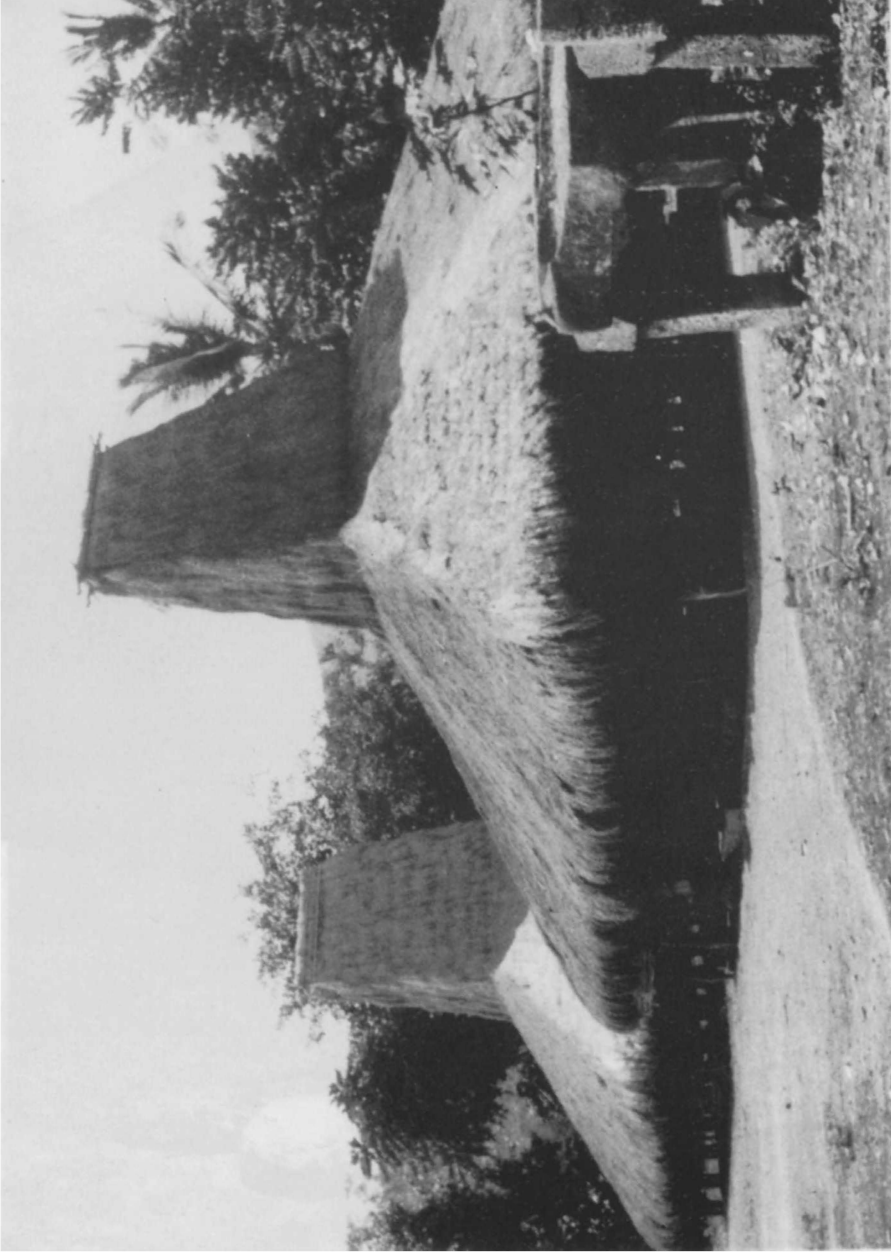

Plate 1a. Peaked houses and graves (Kanoru).

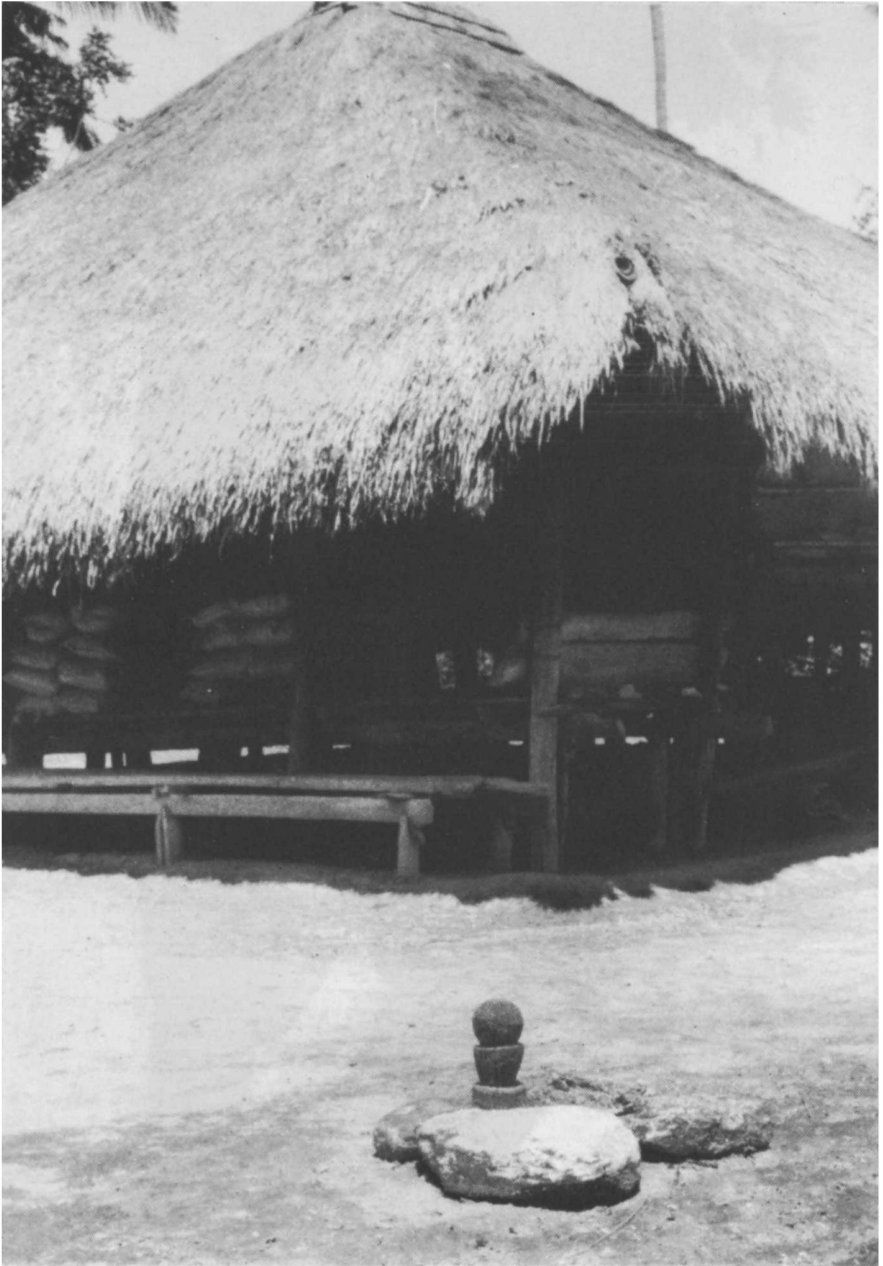

Plate 1b. A yard altar (katoda kawindu) (Parai Kahembi).



Plate 2a. A baby with a rudimentary forelock.

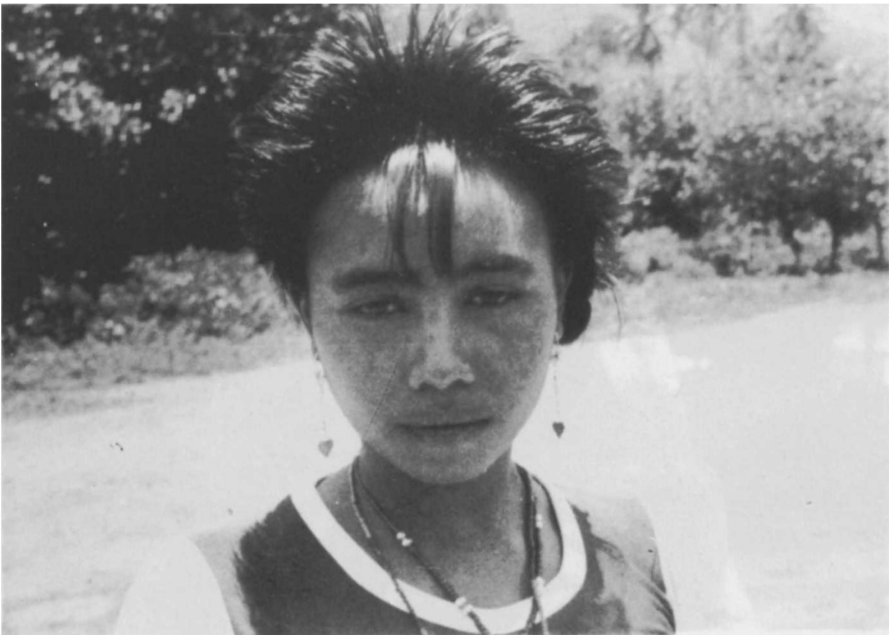

Plate 2b. The unmarried girls' hairstyle.



Plate 3a. The hairstyle of mature men.



Plate 3b. The hairstyle of mature women.



Plate 4a. A grave with 'limbs' and one without (Parai Yawangu).



Plate 4b. Hauling a small gravestone (Parai Yawangu).



Plate 5a. Carrying a corpse from the house to the grave (Parai Yawangu).



Plate 5b. Women placing an offering on a grave (*bànjalu pahàpa*) (Parai Yawangu).



Plate 6a. Paratu during the renovation of the 'Ndewa House' of Ana Mburungu (Parai Yawangu).



Plate 6b. The senior man of the clan Maleri in formal dress (Kayuri).