

**Sensory Motor Concepts in Language & Cognition**

**Liane Ströbel (ed.)**

**d|u|p**

**Hana Filip, Peter Indefrey, Laura Kallmeyer,  
Sebastian Löhnner, Gerhard Schurz & Robert D. Van Valin, Jr.  
(eds.)**

## **Proceedings in Language and Cognition**

**1**

**Proceedings of the International Conference  
“Sensory Motor Concepts in Language & Cognition”**

Liane Ströbel (ed.)

d|u|p

### **Bibliographic information**

#### **published by the Deutsche Nationalbibliothek**

Die Deutsche Nationalbibliothek lists this publication in the Deutsche Nationalbibliografie; detailed bibliographic data is available in the Internet at <http://dnb.dnb.de>.



This work is licensed under the Creative Commons Attribution-NonCommercial-NoDerivs 4.0 License. For details go to <http://creativecommons.org/licenses/by-nc-nd/4.0/>.

**All rights reserved.** No part of this book may be reprinted or reproduced or utilized in any form or by any electronic, mechanical, or other means, now known or hereafter invented, including photocopying and recording, or in any information storage or retrieval system without permission in writing from the publishers.

© düsseldorf university press, Düsseldorf 2016

<http://www.dupress.de>

Cover Design, Layout and Typesetting: Friedhelm Sowa,  $\text{\LaTeX}$

Printed and bound in Germany by docupoint GmbH, Barleben

The body type is Linux Libertine

ISBN 978-3-943460-94-0

eISBN 978-3-11-072030-3

## Contents

Preface	
MICHEL VAN ELK .....	7
Introduction	
LIANE STRÖBEL .....	11
SENSORY-MOTOR CONCEPTS AND LANGUAGE	
1 RAYMOND W. GIBBS	
Experimental and Corpus Studies on Embodied Metaphoric Meaning .....	19
2 VALENTINA CUCCIO	
Inferential Communication in the Embodied Language Paradigm .....	27
3 JOHANN-MATTIS LIST and ANSELM TERHALLE and DANIEL SCHULZEK	
Traces of Embodiment in Chinese Character Formation	
A Frame Approach to the Interaction of Writing, Speaking, and Meaning .....	45
4 WOLFGANG G. MÜLLER	
Motion and Emotion	
The application of sensory-motor concepts	
to the representation of emotion in literature .....	63
THE DIVERSITY OF SENSORY-MOTOR CONCEPTS AND ITS IMPLICATIONS	
5 GERARD STEEN	
Sensory-Motor Concepts and Metaphor in Usage .....	85
6 RALF NAUMANN	
Dynamics in the Brain and Dynamic Frame	
Theory for Action Verbs .....	109
7 SANDER LESTRADE	
The place of Place (according to spatial case) .....	131

8	ANDREA BELLAVIA	
	Force Change Schemas and Excessive Actions: How High-Level Cognitive Operations Constrain Aspect in Idiomatic Constructions .....	147

SENSORY-MOTOR CONCEPTS AND PERCEPTION

9	LIONEL BRUNEL, DENIS BROUILLET and RÉMY VERSACE	
	The Sensory Nature of Knowledge .....	163
10	MARTIN V. BUTZ and DANIEL ZÖLLNER	
	Towards Grounding Compositional Concept Structures in Self-organizing Neural Encodings .....	177
11	ALEX TILLAS	
	Grounding Cognition: The Role of Language in Thinking .....	193
	Postface	
	OLAF HAUK .....	219

# Preface

(Michiel van Elk, Universiteit van Amsterdam)

Thinking back about past events often involves a vivid memory of the people, the places and the context involved. Clear pictures of conference venues and cities that seem frozen in time come to mind when thinking about past scientific meetings. The visual nature of our memories may be taken as an example of the embodied view of language and cognition, which is the general topic of this volume. On this account, our knowledge about the world is grounded in sensory and motor concepts that were acquired through bodily experience. For instance, the concept ‘to grasp’ entails a motor representation of the hand action that is involved in actual grasping. In line with this suggestion, it has been found that the processing of action verbs is associated with activation in similar regions in the premotor cortex that are involved in the actual execution of the action that the verb refers to (Pulvermuller, 2013). Similarly, understanding a concept like ‘grasping’ when observing the action of another person has also been associated with activation in motor-related brain regions, suggesting that a process of motor simulation could support action understanding (Gallese & Lakoff, 2005).

In the last decade, we have seen an enormous interest in embodied cognition theories among scholars from a wide range of different backgrounds. Cognitive neuroscientists have primarily investigated the when and how of activation in modality-specific brain areas in response to language and concept processing (van Elk, van Schie, & Bekkering, 2014). Psychologists have experimentally determined the bidirectional relation between bodily and cognitive processing (Fischer & Zwaan, 2008). Philosophers have focused on the question whether embodied simulation processes meet the necessary and sufficient requirements to support higher-level processes such as mind reading or false belief understanding (Jacob & Jeannerod, 2005). Linguists have investigated how our everyday use of concrete and abstract language in written and spoken form is related to basic sensory and motor concepts (Gibbs, 2003).

I am convinced that this multidisciplinary approach is one of the major strengths of embodied cognition. In a time in which many scientific disciplines have become increasingly specialized, a unifying theory that spans different domains and that ranges from developmental psychology to linguistics and from philosophy to dynamical systems theory has a great potential. At the same time, the challenges faced by such a multidisciplinary approach are non-trivial as each field is characterized by specialist problems that are often defined by the use of a specific jargon. This theoretical challenge was faced directly at the Sensory-Motor-Concepts in Language and Cognition meeting, in which linguists, philosophers, psychologists and neuroscientists participated – all with a shared interest in embodied cognition. As can be seen in the contributions to this volume a wide range of topics was addressed from a variety of different perspectives and encompassing both experimental and theoretical contributions. An intriguing question is whether these different contributions are related and how they could lead to a cross-fertilization of ideas.

A possible starting point for such an integrative attempt is to acknowledge that although the topics addressed by different disciplines may be different, they all share a similar conceptual framework. At this point, an interesting parallel can be drawn with evolutionary accounts of language. Starting from the premise that language conferred an adaptive advantage in the ontogeny of our species, different disciplines have focused on more proximate or ultimate causes of language development (Arbib, 2005). For instance, anthropological accounts have investigated the fossil records to determine precursors of the human vocal tract as a necessary prerequisite for the emergence of language. Developmental psychologists typically conduct experimental studies to investigate how infants over the course of their first years acquire basic language abilities that often seem to go beyond the linguistic input that they received. Neuroscientists have elucidated the neural networks underlying language production and processing and have pointed out a striking overlap between the brain areas involved in the production of language and gestures, suggesting that gestural communication could be a precursor of a prototype of language. Thus, although differing in their topic of investigation and their experimental approach, these findings converge on the idea that language should be understood in terms of its adaptive function and its relation to other more basic forms of action and communication.

Similarly, within the framework of embodied cognition the different approaches converge on the notion that language and cognition involve the use of sensory motor concepts. This may be reflected in the use of metaphors referring to concrete sensory



## *Preface*

motor domains, effects of concrete experiences on word reading and the activation of sensory motor brain areas in response to reading action verbs. Furthermore, each of the different domains can be characterized by similar discussions regarding the question whether an embodied cognition explanation is the only and most viable account of the extant data. For instance, embodied theories of conceptual content are often contrasted with amodal theories, according to which our thinking is based on an internal and symbolic 'language of thought' that is abstracted away from concrete experience (Mahon & Caramazza, 2008). One important argument that is often used in the debate between embodied and amodal theories of cognition is the grounding problem: it remains unclear how concepts derive meaning if they are unrelated to concrete experiences (Barsalou, 2008). The embodied account proposes an intuitive and plausible solution to this problem: the meaning of concepts is derived from the fact that concepts are by definition sensorimotor in nature. More recently, several authors have proposed a hybrid model according to which semantic processing involves both multimodal and modality-specific processing (Louwerse & Jeuniaux, 2010; Ralph, Sage, Jones, & Mayberry, 2010). These ideas may lead to a conceptual refinement of the current theoretical ideas and it would be interesting to see whether eventually theoretical integration is possible, not only within specific research domains such as neuroscience or psychology, but across different domains as well. The collection of papers in this volume provides an excellent first attempt for such an endeavor.

Last but not least, I would like to acknowledge Liane Ströbel without whom this project would not have been possible. She organized a stimulating conference and took the effort of making the proceedings of this meeting available in the form of this special issue of Düsseldorf University Press. It is my sincere hope that the discussions that were started throughout this project will be continued in the future and will lead to a further exchange of people and ideas.



# **Introduction:**

## **Sensory Motor Concepts – at the Crossroad between Language & Cognition**

**(Liane Ströbel)**

This book presents selected papers from the conference “Sensory Motor Concepts in Language and Cognition” organized by the DFG Collaborative Research Center 991: “The Structure of Representations in Language, Cognition, and Science” and held from December 01–03 at the University of Düsseldorf, Germany. It brings together researchers working in the fields of computer linguistics, linguistics, literary, neuroscience, philosophy and psychology, whose work contributes to the interdisciplinary study of cognitive phenomena, specifically in the exploration of the role of sensory motor concepts for language and cognition in general. The aim of this book is to uncover hidden potentials and available prospects of inter and trans-disciplinary research in the field of sensory motor concepts by defining common interests and objectives, and sketching paths for a fruitful interdisciplinary cross-fertilization, cooperative projects, and research transfer.

### **What is so fascinating about sensory-motor concepts?**

According to Barsalou, mental representations used in cognitive tasks are grounded in the sensory-motor system. Therefore it is assumed that the human system of concepts cannot be regarded as either abstract or amodal, but as immediately anchored in the perception, experience and simulation of sensory-motor actions (Barsalou, 2008). This assumption is supported by the following facts: a) sensory-motor knowledge is the most specific and best-differentiated concrete human experience we possess, and b) sensory-motor concepts are not only conceptually simple and easy to encode given the fact that they are part of our everyday life, but due to their semantic complexity they can

also function as cognitive anchorage points for a diverse range of encoding strategies. Therefore, it comes as no surprise that we use sensory-motor concepts as a model for less specific, less differentiated, more abstract knowledge, such as emotions, needs or temporal and spatial relations. The mere fact that even the words to UNDERSTAND and to COMPREHEND (< Latin *prehendere* ‘to catch, to seize’) can be traced back to sensory-motor concepts and that we use sensory-motor-based metaphors, such as to GRASP *an idea* or to HANDLE *a problem* underlines the predominance of sensory-motor source domains in the lexicon. But grammar, too, is full of morphemes which can be traced back to sensory-motor activities. One example is the way we refer to time, e. g. French *le PASSÉ* ‘the past’ (something that has gone by), *MAINTENANT* ‘now’ (< Latin *manu tenendo* ‘in the hand holding’) and *l’AVENIR* ‘the future’ (< Latin *advenire* ‘still to come’) or that we encode emotions or feeling with the help of a possessive verb related to hand action, such as *I HAVE concerns*, etc. Many light verbs and auxiliaries can also be traced back to hand or food actions, such as *to GIVE a smile*, *to TAKE a walk*, or *I am going for a swim*, etc. Similar the copulae in Spanish can be traced back to bodily positions (e. g. *SER* [< Latin *sedere* ‘to sit’] or *ESTAR* [< Latin *stare* ‘to stand’]) or the negation in French to the denying of an action, such as *to not TAKE a STEP* (*ne ... pas* ‘not a step’), etc. (Ströbel, 2010, 2011). In all these examples the underlying strategy is based on the fact that not only the same brain areas are activated whether we fulfill or just imagine an action, but that we can also imagine a sensory-motor task, such as grasping an object without actually grasping it (Gallese and Lakoff, 2005) and that is exactly what makes sensory-motor concepts so suitable for rendering abstract entities less abstract by connecting them to concrete bodily actions (Ströbel, 2014).

The linguistic perspective is covered by theories in cognitive science which support this assumption by asserting that many concepts are grounded in sensory-motor processes (Barsalou, 2008; Gibbs, 2005; Pezzulo et al., 2011; Wilson, 2002). Psycholinguistic studies confirm that different sensorimotor experiences directly shape people’s use and understanding of complex situations and metaphorical statements. Neurological studies using neuroimaging techniques (e. g. fMRI, EEG) and also patient studies (Grossman et al., 2008) have furthermore provided several pieces of the puzzle concerning auditory language perception, reading and language production and deliver valuable insights into this highly developed cognitive function.

The interdisciplinary interest in the topic is also reflected in this volume. Looking at the subject from a number of different perspectives, the various contributions here elaborate the fact that language and body are closely interrelated.

## Sensory-Motor Concepts and Language

The close connection between sensory-motor concepts and language is illustrated in the first part of this volume: **Raymond Gibbs** points out that much of everyday cognition and language has its roots in ongoing bodily experience. In his article, he describes a number of studies from the fields of experimental psychology and corpus linguistics and illustrates how metaphoric ideas and talk emerge from embodied simulation processes. **Valentina Cuccio** purposes a usage-based model of language. Taking the idea that speaking is acting as a starting point, she uses studies on action understanding in order to clarify language production and comprehension and to explain how inferential meaning is deduced from literal sentences. The close connection between sensory-motor concepts and metaphor is discussed by **Johann-Mattis List, Anselm Terhalle and Daniel Schulzek**. Analyzing traces of embodiment in Chinese character formation, they underline the complex interactions between speaking, writing, and meaning. **Wolfgang Müller's** approach starts from the assumption that – much like emotions in actual life – emotions in literature are also grounded in the kinesthetic experience of the body. In his contribution, he illustrates that literature is a productive field for experimentation in matters of embodied cognition.

## The diversity of Sensory-Motor Concepts and its implications

The diversity of sensory-motor concepts and its implications is highlighted in the second part of this volume: **Gerard Steen** divides the group of sensory-motor concepts into five subgroups, namely motor concepts, sensory concepts, sight concepts, sound concepts, location and direction concepts. Furthermore, he also points out that the different groups of sensory-motor concepts are preferred in different registers and that a complete study of sensory-motor concepts would involve a four-way interaction between sensory-motor concepts, metaphor, word class, and register. **Ralf Naumann** outlines a theory of action verbs that combines an abstract, modality-independent component with a modality-specific component located in certain regions of the premotor cortex. His proposal is based on the observation that a verb like *kick* can be used to express diverse types of actions that differ with respect to parameters (e. g. telic vs. atelic, result vs. no result or atomic vs. iteration). **Sander Lestrade** addresses the question whether we should analyze “place”, a generalized location, expressing the absence of a change of location, on a par with mode expressions specifying the type of such a

change, i. e. “source” and “goal”. In his paper, he discusses the status of place markers in a cross-linguistic sample of spatial-case inventories. **Andrea Bellavia** focuses on the connection between aspectuality and embodiment by analyzing a specific class of idiomatic constructions which systematically denote a change of location undergone by a body part at the source domain and which is metaphorically projected into the target domain denoting an event carried out in an intensive fashion. He is advancing a two-level integration model in order to display the semantic compositional representation of such idiomatic constructions.

## **Sensory-Motor Concepts and Perception**

The close connection between sensory-motor concepts and perception is the focus of the last part of this volume: **Lionel Brunel, Denis Brouillet and Rémy Versace’s** approach is based on the close link between memory and perception and analyzes the influence of an auditory memory component upon the sensory processing of a sound by demonstrating the strong linkage between the access to our memory and the reactivation of the relevant sensory components, as part of the function of the respective context or the task. **Martin Butz and Daniel Zöllner** argue that progressively complex concepts and compositional structures can be developed starting from very basic perceptual and motor control mechanisms. They propose that the innateness of concepts may not be directly genetically imprinted, but concepts and compositional concept structures may be indirectly predetermined to develop due to the ontogenetic path laid out in the genes of the organism, the morphological constraints given by the body of the organism, and the environmental reality with which the organism interacts. **Alex Tillas** investigates the relationship between natural language and thinking. He takes as his starting point the assumption that thinking is imagistic, to the extent that conceptual thoughts are built out of concepts which, in turn, are built out of perceptual representations; and that concepts – the building blocks of thoughts – are association-istic in their causal patterns. His claim is supported by independent empirical evidence obtained from work done with aphasic subjects.

## References (Preface & Introduction)

- Arbib, M. A. (2005). From monkey-like action recognition to human language: An evolutionary framework for neurolinguistics. *Behavioral and Brain Sciences*, 28(2), 105–167.
- Barsalou, L. W. (2008). Grounding symbolic operations in the brain's modal systems. In G. R. Semin, & E. R. Smith (Eds.), *Embodied grounding: Social, cognitive, affective, and neuroscientific approaches* (pp. 9–42). New York, NY, US: Cambridge University Press.
- Fischer, M. H., & Zwaan, R. A. (2008). Embodied language: A review of the role of the motor system in language comprehension. *Quarterly Journal of Experimental Psychology*, 61(6), 825–850.
- Gallese & Lakoff (2005). The Brain's Concepts: The Role of the Sensory-Motor System in Reason and Language. *Cognitive Neuropsychology*, 2005, 22:455–479.
- Gibbs, R. W. (2003). Embodied experience and linguistic meaning. *Brain and Language*, 84(1), 1–15.
- Gibbs, R. W. J. (2005). The psychological status of image schemas. In B. Hampe (Ed.), *From perception to meaning* (pp. 113–135). Berlin/New York: Mouton de Gruyter.
- Glenberg, A. M., & Kaschak, M. P. (2002). Grounding language in action. *Psychonomic Bulletin & Review*, 9, 558–565.
- Grossman, M., Anderson, C., Khan, A., Avants, B., Elman, L., & McCluskey, L. (2008). Impaired action knowledge in amyotrophic lateral sclerosis. *Neurology*, 71(18), 1396–1401.
- Jacob, P., & Jeannerod, M. (2005). The motor theory of social cognition: a critique. *Trends in Cognitive Sciences*, 9(1), 21–25.
- Louwerse, M. M., & Jeuniaux, P. (2010). The linguistic and embodied nature of conceptual processing. *Cognition*, 114(1), 96–104.
- Mahon, B. Z., & Caramazza, A. (2008). A critical look at the embodied cognition hypothesis and a new proposal for grounding conceptual content. *Journal of Physiology - Paris*, 102(1–3), 59–70.
- Pezzulo, G., Barsalou, L.W., Cangelosi, A., Fischer, M.A., McRae, K., Spivey, M. (2011). The mechanics of embodiment: A dialogue on embodiment and computational modeling. *Frontiers in Cognition*, 2(5), 1–21.
- Pulvermuller, F. (2013). Semantic embodiment, disembodiment or misembodiment? In search of meaning in modules and neuron circuits. *Brain and Language*, 127(1), 86–103.

- Ralph, M. A. L., Sage, K., Jones, R. W., & Mayberry, E. J. (2010). Coherent concepts are computed in the anterior temporal lobes. *Proceedings of the National Academy of Sciences of the United States of America*, 107(6), 2717–2722.
- Ströbel, L. (2010). *Die Entstehung einer neuen Kategorie – Leerverben als paralleler Kopulastrang*. Frankfurt/Main: Peter Lang.
- Ströbel, L. (2011). Invisible, visible, grammaticalization. In Callies, M. Lohöfer, A. Keller, W. (Eds.), *Bi-Directionality in the Cognitive Sciences: Avenues, challenges, and limitations*. viii, 313 pp. (pp. 211–234), New York/Amsterdam: John Benjamins.
- Ströbel, L. (2014). Sensomotorische Strategien & Sprachwandel, In E. Pustka & S. Goldschmitt (eds.), *Emotionen, Expressivität, Emphase*. Berlin: Erich Schmidt Verlag.
- van Elk, M., van Schie, H. T., & Bekkering, H. (2014). Action Semantics: A unifying conceptual framework. *Physics of Life Reviews*.
- Wilson, M. (2002). Six views of embodied cognition. *Psychonomic Bulletin & Review*, 9, 625–636.



# **SENSORY-MOTOR CONCEPTS AND LANGUAGE**



RAYMOND W. GIBBS

## Experimental and Corpus Studies on Embodied Metaphoric Meaning

Raymond W. Gibbs, Jr.  
University of California, Santa Cruz  
Department of Psychology  
Santa Cruz, CA 95064  
USA

[gibbs@ucsc.edu](mailto:gibbs@ucsc.edu)

### Abstract

An important claim in cognitive science is that much of everyday cognition and language has its roots in ongoing bodily experience. One place where embodiment is critical is in the creation and use of metaphoric talk. This article describes some of the studies from experimental psychology and corpus linguistics demonstrating how metaphoric ideas and talk emerge from embodied simulation processes where people imagine themselves engaging in the actions mentioned in the language (e. g., “grasp the concept”). Some of this newer work demonstrates how experimental studies can test ideas from linguistics, but that corpus studies can also be used to examine falsifiable hypotheses first seen in psychology, on the embodied nature of metaphoric meaning.

## 1 Introduction

Embodied metaphor refers to the idea that many metaphoric concepts are grounded in recurring patterns of bodily experience (Gibbs, 2006; Lakoff & Johnson, 1999). For example, both “I am struggling to get a good start in my career” and “My marriage is on the rock” refers to the concept that LIFE IS A JOURNEY. People’s journey experiences, where they start at some source point, follow a path, and end up at some goal or destination, are used to better structured more abstract concepts like life or career or relationship. Much research in cognitive linguistics shows the importance of embodied source domains in metaphoric ideas and talk.

To a significant extent, the experimental research on embodied metaphor is seen as verification for cognitive linguistic theories of embodied metaphor. But the rise of new work in corpus linguistics now sets the stage for a different kind of interdisciplinary collaboration between linguists and psychologists. This paper presents one example of this interaction between experimental psychology and corpus linguistics on the topic of embodied metaphor. My aim is to demonstrate some of the ways these two fields can be integrated; especially in regard to testing specific potentially falsifiable hypotheses.

## 2 Experimental Studies on Embodied Metaphor

Many psycholinguistic studies have been conducted over the last 25 years to explore the ways that embodied metaphors may be recruited during people's use and understanding of metaphoric language (Gibbs & Colston, 2012). These varied psychological findings, collected using a variety of experimental methods, indicate that the metaphorical mappings between embodied source domains and abstract target domains partly motivate people's understanding of the specific figurative meanings of many conventional and novel metaphors.

For example, some experiments examined how immediate bodily experience influence metaphor interpretations. In one series of studies on metaphorical talk about time, students waiting in line at a café were given the statement "Next Wednesday's meeting has been moved forward two days" and then asked "What day is the meeting that has been rescheduled?" (Borodistky & Ramscar, 2002). Students who were farther along in the line (i. e., who had thus very recently experienced more forward spatial motion) were more likely to say that the meeting had been moved to Friday, rather than to Monday. Similarly, people riding a train were presented the same ambiguous statement and question about the rescheduled meeting. Passengers who were at the end of their journeys reported that the meeting was moved to Friday significantly more than did people in the middle of their journeys. Although both groups of passengers were experiencing the same physical experience of sitting in a moving train, they thought differently about their journey and consequently responded differently to the rescheduled meeting question. These results suggest how ongoing sensorimotor experience has an influence on people's comprehension of metaphorical statements about time.

One idea that has attracted a good deal of attention in cognitive science is the possibility that much cognition and language is organized around embodied simulation processes (Gibbs, 2006). Several different behavioral studies provide support for the view that embodied simulations play some role in people's immediate processing of verbal metaphors (Gibbs, 2006). People may create partial embodied simulations of speakers' metaphorical messages that involve moment-by-moment "what must it be like" processes that make use of ongoing tactile-kinesthetic experiences (Gibbs, 2006). Understanding abstract, metaphorical events, such as "grasping the concept," for example, is constrained by aspects of people's embodied experience as if they are immersed in the discourse situation, even when these events can only be metaphorically and not

physically realized (i. e., it is not physically possible to grasp an abstract entity such as a “concept”).

For instance, people’s speeded comprehension of metaphorical phrases, like “grasp the concept” are facilitated when they first make, or imagine making, a relevant bodily action, such as a grasping motion (Wilson & Gibbs, 2007). One unique study revealed that people walked further toward a target when thinking about a metaphorical statement “Your relationship was moving along in a good direction” when the context ultimately suggested a positive relationship than when the scenario alluded to a negative, unsuccessful relationship (Gibbs, 2012). This same difference, however, was not obtained when people read the nonmetaphorical statement “Your relationship was very important” in the same two scenarios. People appear to partly understand the metaphorical statement from building an embodied simulation relevant to LOVE RELATIONSHIPS ARE JOURNEYS, such that they bodily imagine taking a longer journey with the successful relationship than with the unsuccessful one.

A different set of experiments examined people’s understanding of the embodied metaphor TIME IS MOTION by first asking people to read fictive motion sentences, as in “The tattoo runs along his spine” (Matlock, Ramscar, & Boroditsky, 2005). Participants read each fictive motion statement or a sentence that did not imply fictive motion (e. g., “The tattoo is next to the spine”), and then answered the “move forward” question (e. g., “The meeting originally scheduled for next Wednesday has been moved forward two days.”). People gave significantly more Friday than Monday responses after reading the fictive motion expressions, but not the non-fictive motion statements. These results implies that people inferred TIME IS MOTION conceptual metaphor when reading the fictive motion expressions which primed their interpretation of the ambiguous “move forward” question.

A follow-up group of studies had people engage in abstract motion to see if it influenced their responses to the “move forward” questions (Matlock et al., 2011). Participants first filled in the missing numbers in an array that either went in ascending (e. g., between 5 and 17) or descending (e. g., between 17 and 5) order. When the participants then answered the “move forward” question, they gave far more Friday responses after filling in the numbers for the ascending condition and gave more Monday answers having just filled in the numbers for the descending order condition. People appear to understand the meaning of time metaphors through a mental simulation of the implied motion, findings that are congruent with the claim that conceptual metaphors are active parts of verbal metaphor processing.

These different behavioral studies offer support for cognitive linguistic claims about embodied metaphor, but do so in a more systematic manner that allows for specific hypotheses to be tested, and possible falsified.

### 3 Psycholinguistics and Corpus Linguistic Studies

The experimental studies reviewed above all employed constructed examples, following most cognitive linguistic work on embodied metaphor. But there is now more emphasis in linguistics on corpus studies examining the use of metaphor in naturalistic discourse. For example, read the words *path* and *road* when they are used in the two different metaphorical contexts below, and consider whether they convey the same meaning (Johansson-Falck & Gibbs, 2012):

1. The Spaniard lost 10–8 6–3 2–6 8–6 to Charlie Pasarell in 1967. And even if Agassi survives his first test, his **path** to a second successive final is strewn with trip wire, with former champions Boris Becker and Michael Stich top seed Pete Sampras and powerful ninth seeded Dutchman Richard Krajicek all in his half of the draw. [emphasis ours]
2. The learner who is well on the **road** to being a competent reader does bring a number of things to the task, a set of skills and attributes many of which are still developing. He or she brings good sight and the beginnings of visual discrimination. [emphasis ours]

The meaning of *path* may be appropriate in (1) because of the uneven nature of Agassi's journey toward winning the tennis match, while *road* seems apt in (2) because the journey becoming a competent reader's is well-established, and one that many people have metaphorically travelled. Previous corpus linguistic studies show that metaphorical uses of *path*, *road*, as well as *way*, are not only structured according to primary/conceptual metaphors such as ACTION IS MOTION, LIFE/A PURPOSEFUL ACTIVITY IS A JOURNEY, and PURPOSES ARE DESTINATIONS, but also appear to be influenced by people's embodied experiences with the specific concepts that these terms refer to in their non-metaphorical uses (Johansson Falck, 2010). Thus, both similarities and differences between real world paths, roads and ways are reflected by how metaphorical paths, roads and ways are described both by the kinds and frequencies of obstacles that people face on these journeys, and the kinds of actions people engage in, on, or near metaphorical paths, roads or ways.

Johansson-Falck and Gibbs (2012) conducted two studies, one a psychological questionnaire and the second a corpus linguistic investigation to see if embodied simulation processes are also prominent in people's use and understanding of expressions like *his path to a second successive final is strewn with trip wire* in reference to Agassi's metaphorical journey to a tennis tournament championship as seen in (1) above. Thus, people's embodied simulation in regard to their imaginative understandings of traveling along different paths and roads provides a major constraint on what gets mapped in various metaphorical instances of *path* and *road*.

A first study investigated people's experiences with paths and roads. Participants were given a booklet that first asked them to create a mental image of "being on a path" and then, on the next page, to form a mental image of "being on a road." Following this, the participants turned the page and saw a series of questions, each of which could be answered by circling either the word *path* or *road*. Analysis of participants' responses revealed the following qualities that people strongly felt they experienced along paths and roads.

#### Paths

Something you travel on by foot  
More up and down  
More aimless in their direction  
Something you stop on more often  
More problematic to travel on

#### Roads

Straighter  
Wider  
Paved  
Lead to a specific destination  
Something you drive on

Overall, the results of this first study employing human participants demonstrated that people's imaginative perceptions of paths and roads focus on the more central rather than peripheral aspects of their bodily actions relevant to these real-world artifacts (e. g. on driving, but not walking, on roads, and on walking, but not driving, on paths etc.). Traveling along paths is clearly different in important ways from that of roads.

A second study in this series provided a detailed corpus analysis of 240 metaphorical uses of *path* and 47 instances of *road* in the *British National Corpus*. Most generally, the corpus findings matched the intuitions we obtained in our first psychological study. For instance, *path* was frequently used to talk of more difficult, and varied, difficulties in travel in these contexts (23%), but roads were never used in this way. On the other hand, only 12% of the *path* examples, but 60% (based on only 3 of 5 instances) of the *road* instances included explicit mention about where the artifact leads (i. e. *to eternity, to ruin, to stardom*). The same differences are seen in the ways that *path* and *road* are used to describe the target domain of PURPOSEFUL ACTIVITIES/LIVES. Again, there were many more mentions of the difficulties associated with travel along *paths* (38%) than *roads* (13%). These difficulties may be related to obstacles in or on the path/road (e. g., *their path to a winning was obstructed by an excellent performance from India*, or *the constant traps and barriers laid by the forces that would block our path and drag us down*), or they correspond to a difficult area that someone or something is leaving or trying to leave e. g., (*[people] seek a path out of divisive ideological camps*, or *break though the barriers of error to seek the road to truth*).

Paths, but not roads, are connected with choices between alternative courses of action. 21% of the *path* instances with the function of describing PURPOSEFUL ACTIVITIES/LIVES, but none of the *road* cases included words or phrases suggesting that there may be more than one path to achieve a goal (e. g. *only, best, the same, typical, a different path to the same goal*). The term *road*, on the other hand, is more often used in talk about activities that people want to be efficient than paths (e. g., PURPOSEFUL ACTIVITY/LIFE and financial/political developments/processes), and *paths* are more often used to describe actions or developments that may have a more hesitant, aimless, or step by step, quality than *roads* (e. g., COURSES OF ACTION/WAYS OF LIVING, other types of DEVELOPMENT and paths in COMPUTER/MATHEMATICS DEVELOPMENTS/PROCESSES). *Path* is used in talk about processes and *road* in talk about ends of processes and result. Finally, *path* is more closely connected to choices between different courses of action, compared to the much more efficient and single goal-oriented *road*.

The link between people's imaginative understandings of paths and roads and the metaphorical uses of *path* and *road* in discourse has several theoretical implications. First, people mentally simulate different kinds of actions in journeys along paths and roads and apply these experiences to shape their in-the-moment metaphorical understandings of abstract actions through the use of *path* and *road*. Second, the consistent patterns of findings for the psychological survey and the corpus investigation suggest



that metaphorical language including terms that refer to artifacts is to some significant extent predictable. Most importantly, our combination of a psychological investigation of people's experiences of paths and roads with an extensive corpus analysis of metaphorical *path* and *road* shows that neither a conceptual metaphor theory explanation in terms of mappings at the levels of primary or complex metaphor, nor a purely social theory in which the use of *path* and *road* are negotiated between speakers, sufficiently account for the link between metaphorical meaning, mind and world. Instead, people's imaginative perceptions of paths or roads are influenced by their understandings of these artifacts through embodied experience, which can then be simulated in the context of metaphoric thinking and speaking.

#### **4 Conclusion**

There is a large body of both experimental and corpus linguistic work on the embodied nature of many metaphoric concepts. The studies described in this article show how experimental and corpus research can nicely feed one another to create hypotheses that can be tested using either experimental or corpus linguistic methods. More specifically, cognitive linguistic studies strongly suggest that people's recurring bodily experiences critically motivate aspects of their metaphoric talk. Psycholinguistic studies confirm that different sensorimotor experiences directly shape people's use and understanding of various metaphorical statements. But the psycholinguistic work is limited in testing people's immediate understanding of individual metaphors and does not explore the role of embodiment in larger discourse contexts. However, recent corpus linguistic research has demonstrated how specific hypotheses can be tested by examining detailed patterns of metaphoric language use within naturalistic speech and text (also see Stefanowitsch, 2011). This work shows that the metaphorical uses of certain words is not simply a social process or accomplished via the direct activation of encoded primary or conceptual metaphors. Instead, similar to the experimental research, corpus linguistic methods are capable of revealing the constraining presences of embodied simulation processes in the ways people think and speak of different abstract, and in this case metaphorical, concepts. In this way, then, corpus linguistic analyses do not simply offer ideas for possible testing using behavioral methods, but can be the site of testing explicit hypotheses themselves.

Embodied experience seems critical to people's use and understanding of metaphoric idea and language, a conclusion that vastly differs from traditional disembodied theo-

ries of metaphorical meaning and language use. Of course, many other factors, ranging from purely linguistic, social and cultural processes also shape the creation and interpretation of metaphoric discourse. But it is unlikely that any of these forces can act alone, apart from the influence of bodily activity. The studies described in this article provide additional evidence that the embodied nature of metaphoric concepts is best characterized in terms of embodied simulation hypotheses in which people imagine themselves engaged in the actual events mentioned in the language, even when these involves actions that are physically impossible to perform in the real world.

## 5 References

- Boroditsky, L., & Ramscar, M. (2002). The roles of body and mind in abstract thought. *Psychological Science*, 13, 185–189.
- Gibbs, R. (2006). *Embodiment and cognitive science*. New York: Cambridge University Press.
- Gibbs, R. (2011). Evaluating conceptual metaphor theory. *Discourse Processes*, 48, 529–562.
- Gibbs, R. (2012). Walking the walk while thinking about the talk: Embodied interpretation of metaphorical narratives. *Psycholinguistic Research*.
- Gibbs, R., & Colston, H. (2012). *Interpreting figurative meaning*. New York: Cambridge University Press.
- Johansson Falck, M. (2010). Are metaphorical paths and roads ever paved? Corpus analysis of real and imagined journeys. *Review of Cognitive Linguistics*, 8, 93–122.
- Johansson-Falck, M., & Gibbs, R. (2012). Embodied motivations for metaphoric meaning. *Cognitive Linguistics*, 23, 251–272.
- Lakoff, G. & Johnson, M. (1999). *Philosophy in the flesh*. New York: Basic Books.
- Matlock, T., Ramscar, M., & Boroditsky, L. (2005). On the experiential link between spatial and temporal language. *Cognitive Science*, 29, 655–664
- Matlock, T., Holmes, K., Srinivasan, M., & Ramscar, M. (2011). Even abstract motion influences the understanding of time. *Metaphor and Symbol*, 26, 260–271.
- Stefanowitsch, A. (2011). Cognitive linguistics as cognitive science. In M. Callies, W. Keller, & A. Lohofer (Eds.), *Bi-directionality in the cognitive sciences* (pp. 295–310). Amstersdam: Benjamins.
- Wilson, N., & Gibbs, R. (2007). Real and imagined body movement primes metaphor comprehension. *Cognitive Science*, 31, 721–731.

VALENTINA CUCCIO

## Inferential Communication in the Embodied Language Paradigm

Valentina Cuccio  
Humboldt University  
Berlin School of Mind and Brain

valentina.cuccio@unipa.it

University of Palermo  
Department of Humanities

### Abstract

The aim of this paper is to focus on a problem that has not been sufficiently attended to by researchers in the embodied language paradigm. This problem concerns the inferential level of communication. In real-life conversations implicit and inferential meaning is often the most important part of dialogues. However, embodied language researches, up to now, have not sufficiently considered this aspect of human communication. Simulation of the propositional content is not sufficient in order to explain real-life linguistic activity. In addition, we need to explain how we get from propositional contents to inferential meanings. A usage-based model of language, focused on the idea that speaking is acting, will be presented. On this basis, the processes of language production and comprehension will be analyzed in the light of the recent findings on action comprehension.

Keywords: Inferential Communication, Embodied Language, Motor Simulation

## 1 Some remarks on the Embodied Language Paradigm

According to many authors (Barsalou, 1999; Gallese 2008; Gallese & Lakoff, 2005; Pulvermüller, 1999, 2002) linguistic meaning is embodied. This means that the comprehension of an action-related word or sentence activates the same neural structures that enable the execution of that action. Gallese (2008) presented this hypothesis as the “neural exploitation hypothesis”. Language exploits the same brain circuits as action does. According to this hypothesis, our linguistic and social abilities are grounded in our sensory-motor system. The Mirror Neuron System (MNS) is the neural structure that supports both our motor abilities and our social skills, language included. Thus, in this account, actions and language comprehension are mediated by motor simulation. We understand actions such as John taking a bottle from the refrigerator and drinking some milk, at least in part, by simulating the same actions in the Mirror Neuron System; and we understand a sentence such as “John took the bottle from the refrigerator and

drank some milk”, at least in part, by simulating the corresponding actions in the same neural network that executes those actions.

This seems to hold true even for the understanding of abstract linguistic meanings. Indeed, in that case, *metaphorical thought* allows us to map from a sensory-motor domain to an abstract domain. This mechanism, according to Gallese and Lakoff (2005), is the basis for the construction and comprehension of abstract meanings and concepts.

Now, imagine entering a bar, you look at the barman and say: “Water”. Or imagine being a firefighter, you are in front of a building on fire and you scream out loud to your co-worker: “Water!”. Imagine getting lost in the desert. At some point you see an oasis and say aloud to your exhausted friend: “Water”. In each of these cases, the word ‘water’ by itself expresses a full proposition, and it is a different proposition in each case (Wittgenstein, 1953; Lo Piparo, 2007).

It is also very likely that, in all of these examples, linguistic comprehension implies a mental simulation by the interlocutor. And it is also very likely that in these three different contexts the very same word will enable three completely different mental simulations. In the first case the simulation will probably concern the actions of putting water in a glass and giving the glass to a customer. In the second case, the simulation will concern the action of pumping water on the building using a fire hydrant. And finally, in the last example the interlocutor will comprehend that very same word as an information, “there is water over there”, and as an invitation, “let’s go to drink some water”. His mental simulations will most likely concern these linguistic contents.

The very same word, then, can express full propositions with entirely different meanings. None of these possible meanings is literally present in the speech act. Indeed, propositions produced and comprehended in these examples are implicit and inferential. Considering that, in the simulative account, language comprehension is realized by means of an embodied simulation of the propositional content, how can we explain, in this account, the simulation of a full proposition starting only from the uttering of a single word?

Imagine now a boy that returns home. His father sees him and asks: “So?” and the boy answers with a smile: “It was fine”. This conversation can only be understood by someone who shares the same background knowledge as the participants. For example, the boy could have returned from an exam, a job interview, or from a date with a girl he really likes, and the father is asking about this. Thus, it is likely that in this case both the father and the son are performing a mental simulation. But is the mental simulation pertinent to the words “So” and “That’s fine” or to the implicit meanings that can be

inferred from those words? The latter is more likely. Consider that these very same words uttered in a different context by different people would have a very different meaning.

The aim of this paper is to focus on a problem that only very recently has started to be addressed by researchers working in the embodied language paradigm. This problem concerns the inferential level of communication. In real-life conversations, implicit and inferential meaning is often the most important part of a dialogue. However, up to now embodied language researches have not sufficiently considered this aspect of human communication.

Indeed the most influential model of language at work in embodied language researches is mainly based on the idea that we have semantic circuits in our brain where our linguistic knowledge, in terms of words meanings, is stored in a pretty stable way (Pulvermüller 2002). Language comprehension, thus, implies the activation of our semantic knowledge that is often coded in terms of action, perception or emotion knowledge, according to the Wittgensteinian idea that different word kinds imply different form of knowledge (Pulvermüller 2012). However, a semantic-based model of language understanding, that basically relies on a fixed and conventional repertoire of meanings, is not sufficiently explicative of what really happens when people speak. A simulation of propositional content does not sufficiently explain real-life linguistic activity. Indeed, the question that must be addressed is: what does it mean for the two utterances in the above dialogue to be subjected to a simulation of their propositional content. In addition, we need to explain how we get from the propositional content to the implicit content and inferential meaning. Simulative understanding is “immediate, automatic and almost reflex-like” (Gallese 2007). Pulvermüller (2012, 442) describes the brain processes that reflect comprehension as immediate, automatic and functionally relevant as well. However, can this definition of comprehension processes explain how we get from literal meaning to inferential meaning? This question should push us to reflect on the nature of automatic processes and to deepen our understanding of such processes. It could be that even automatic and subpersonal processes are sensible to the context. Findings from recent empirical studies support this hypothesis. Contextual effects on motor simulation during linguistic processing have been assessed in behavioural (e.g. van Dam, Rueschemeyer, Lindemann, & Bekkering 2010) and functional magnetic resonance imaging (fMRI) studies (e.g. Papeo, Rumati, Cecchetto & Tomasino 2012; van Ackeren, Casasanto, Bekkering, Hagoort, & Rueschemeyer, 2012). These findings suggest that contextual information prevails over semantics. However, how precisely this

happens is still an open question. Anyhow, these data raise an issue that all semantic-based account of language understanding should address. Also, not trivial philosophical implications on our understanding of what semantics really is and how it works and on the notion of automaticity should be drawn from these data.

It is worth noting that in this paper it is not questioned the fact that language is embodied. Instead, the aim of the paper is to highlight the limitations that studies mainly focused on descriptive and action related usages of language inevitably have. These limitations have been mainly undervalued by researchers working in the embodied language paradigm. Even in those studies that addressed non-literal usages of language, experimental sets seem to miss a realistic pragmatic context that can trigger a process of inferential communication. They rarely take into account more pragmatically complex dialogues such as, for example, the one between the father and son previously discussed. Thus, if these kinds of stimuli, by far much closer to real-life linguistic activity, were taken into consideration, we would probably see that language production and comprehension imply the activation of the Mirror Neuron System in a peculiar, pragmatically-based, way. In other words, as some studies already suggest (Papeo et al. 2012; van Ackeren et al. 2012; van Dam et al. 2010), motor simulation occurring during linguistic comprehension is very likely contextually determined and not fixedly linked to the literal meaning of words.

Consequentially, there is a second related problem that it is worth noting here. It concerns the definition of meaning and semantics adopted, sometimes implicitly sometimes explicitly, in the embodied language paradigm.

The language model adopted in this paradigm seems to be that of the dictionary. In the *dictionary model* of language, there is a fixed repertoire of words and each word is associated to a meaning. Of course, language seems to also show some imperfections such as polysemy and homonymy, but even these facts can be explained by the model of the dictionary. Indeed, each acceptance of a polysemic or homonym word works as if it were a different word with its own related meaning that we can eventually find in the dictionary. The word's context allows the activation of the right meaning in any sentence. However, sometimes the context is too ambiguous, and this leads to misunderstandings. This appears to be the only room left for pragmatics in embodied language research (even when contextual effects are taken into consideration, these are considered as something outside the speaker that, in some way, interacts with fixed meanings stored in the speaker "heads").

In contrast, the pragmatic dimension of language is more extensive than the problem of polysemy and homonymy even though they are more complex than what has been sketched-out here. A more comprehensive account of language should be provided in order to address issues concerning the pragmatic dimension of language.

### **1.1 A Usage-Based Model of Language**

Since the first half of the nineteenth century, researchers in the fields of the Philosophy of Language, Pragmatics, Linguistics, Discourse Psychology and even Anthropology have been outlining a usage-based model of language. The vast and very rich literature on this topic numbers among its contributors philosophers such as Wittgenstein, Austin and Grice, linguists such as Levinson and Horn, discourse psychologists as Barlow and Kemmer and anthropologists such as Sperber. Although partially different currents of thought can be identified among these researchers, their accounts present some common features. Hence, the next question to address is: what are the defining features of the usage-based model of language?

A good starting point is an examination of semantics and its role in the construction of linguistic meaning. The key to understanding the role of semantics is the distinction between *what is literally said* and *what is intended* by the utterance of a sentence (the sentence's meaning and the speaker's meaning, in Grice's words). This distinction in itself suggests that the semantic level only, with compositionality rules, is not sufficient in order to understand linguistic activity. A second, pragmatic, step of language comprehension seems to be necessary. However, the problem is to determine to what extent the first semantic level can be considered autonomous from the pragmatic level of language. In other words, is there a residual literal meaning that we can call semantics or, should meaning be always considered as contextually determined at every level? In the latter option holds true, language understanding does not proceed from a minimal, literal, proposition to the intended meaning. Pragmatic processes operate extensively at every level of language comprehension.

Currently, in the pragmatic debate these two different accounts of the semantic/pragmatic distinction are known as Minimalism and Contextualism. However, independently of this debate, neither Minimalism nor Contextualism accepts the idea that a consideration of semantics as a fixed repertoire of meanings, can sufficiently explain the process of language production and comprehension. Semantics does not seem to be enough. In fact, if we look at what usually happens in real-life conversations again,

we will see that linguistic meaning is tightly linked to the context of speech, to the background knowledge of the speakers, to their shared knowledge and to their aims in that context (Carapezza & Biancini in press). To know the dictionary definition of each word plus the rules of their composition is not sufficient in order to receive the speaker's meaning.

We all perfectly know the corresponding definition of the words 'so', 'that', 'is' and 'fine' in the dictionary. However, this knowledge is not sufficient in order to understand what the father and son in our example are talking about. Hence, to understand language we need to understand how, when, where, by who and why words are used. This idea leads to a definition of meaning that is very different from the one presented in the *dictionary model* of language. In this account, meaning is defined by the use of a word in a specific context.

We can now turn to another point. Linguistic meaning is the product of a mutual identification of communicative intentions. Without the possibility of understanding other people mental states, and in particular their communicative intentions, language would be a mere code. Indeed, it is the ability to understand other people's mental states and in particular their communicative intentions that makes irony, figurative language, jokes or even misunderstandings possible. If we only simulate the propositional content of an ironic utterance, how can we understand its ironic meaning? And how can we get the ironic meaning if we do not understand the presuppositions and implicatures of that sentence? And how can we understand the presuppositions and implicatures of a proposition if we do not understand other people mental states?

In other words, how can we get the meaning of this sentence without implying a complex mindreading ability?

This last point allows us to make a leap forward. Indeed, the key to understanding inferential communication is exactly a complex mindreading ability. The automatic, immediate and reflex-like form of mindreading realized by embodied simulation is not sufficient in order to explain inferential communication.

Questions concerning the identification of the functional mechanisms of mindreading involved in real-life conversations and their neural implementation are still open.

These issues will be discussed in the following paragraphs.



## **2 Becoming Ironic. How Do Children Develop an Understanding of Irony?**

Irony is a very clear example to highlight the role of mindreading in language comprehension. Moreover, studies on the development of the ability to understand irony can help us to identify those steps of socio-cognitive development that we need to achieve in order to become ironic.

Irony has been a widely addressed topic of study for more than two millennia. In the 1<sup>st</sup> century AD, the Roman rhetorician Quintilian defined irony as a figure of speech consisting in intending the opposite of what is literally said – *contrarium quod dicitur intelligendum est*. This definition is still very popular along with many others different theories of irony nowadays available.

As Colston and Gibbs (2007) noted in their introduction to the edited volume “Irony in Thought and Language”, a host of different theories of irony have been presented and are currently discussed. And each of them seems to be able to explain only a part of this very complex phenomenon. For some researchers (Wilson and Sperber, 1992), irony implies an echoic reference to a desired or expected event while an undesired event is taking place. For others (Clark and Gerrig, 1984), irony is the realization of a pretence. The speaker is acting out the beliefs or behaviours of others and in doing so he is taking distance from them.

These two accounts are just examples, though influential, but by no means representative of the huge quantity of theories of irony that are presently discussed (see Colston and Gibbs, 2007 for a review of contemporary theories of irony).

However, despite the number of different definitions, irony is, beyond all doubt, a very good example of inferential communication. This is true for many reasons. In order to receive the ironic meaning of an utterance, we need to understand the presuppositions and implicatures of that utterance. Indeed, the use of irony implies, at least, a form of violation. Irony can express the violation of expectations (Colston, 2000; Kumon-Nakamura, Glucksberg, & Brown, 1995; Wilson and Sperber, 1992), the violation of relevance, appropriateness and manner (Attardo, 2000), or the violation of the Gricean Maxim of quality (Kumon-Nakamura et al., 1995). In any case, each of these forms of violation entails a presupposed shared knowledge. Indeed, in order to feel that something is the expression of a violation, we need to know, implicitly or explicitly, that something different should have been the case in that context. Speaker and addressee need to share this knowledge and they need to reciprocally know that

they share this kind of knowledge. If not, irony will not succeed. Moreover, if irony succeeds, we understand the meaning of the speaker's intentional violation. And this meaning is not explicitly expressed, the speaker and addressee need to implicate it. Thus, the processing of irony entails the ability to manage with presuppositions (the shared knowledge) and implicatures (meanings inferred from violations). Furthermore, the addressee needs to comprehend the goal of the speaker in order to understand his ironic meaning and to make reference to context (both the physical context of speech and the background knowledge of the speaker and the addressee). These issues hold true for many other language usages, but in irony comprehension they are particularly evident.

How can we explain the process of inferential understanding in an embodied account? That is, how can we explain the comprehension of something that is not literally present in the sentence but only presupposed and implicated by it? Can we hypothesize that it is a chain of simulations that leads to the inferential, ironic meaning? Does this chain of simulation need to start with the simulation of the propositional content or not? Does the process of inferential understanding need to be implicit or explicit? These are empirical open questions that are waiting for experimental studies.

A look at the development of irony-understanding might help to clarify these experimental questions. Indeed, developmental studies can help us to identify the cognitive mechanisms necessary for irony-understanding and this could make the task of looking for their neural implementation easier.

Why do developmental studies of irony matter? Developmental studies on irony tell us something about the step of cognitive development that is necessary in order to produce and understand irony. These studies are focused on the identification of the social-cognitive mechanisms needed in the production and understanding of irony. On the other hand, studies on the production and comprehension of irony in adults seem to be more focused on the pragmatic description of the phenomenon. Adults studies seem to be interested in the social functions of irony, in its communicative effects, in the role played by the context in the construction of ironic utterances and so on and so forth. They do not seem to be strictly focused on the identification of the social-cognitive mechanism underlining the use of irony as developmental studies would (Filippova and Astington, 2010).

As Filippova and Astington (2010) have recently claimed, much of the research that has been carried out in the developmental line of study (e. g., Happé, 1993, 1995; Sullivan, Winner, & Hopfield, 1995; Winner, Brownell, Happé, Blum, & Pincus, 1998; Winner

& Leekam, 1991) has highlighted the fact that the ability to make second-order mental state attributions is required in order to be able to produce and comprehend irony. This claim is so strong in developmental studies that the production and comprehension of irony is often used as a test for evaluating the possession of a sophisticated mindreading ability, i. e. a full Theory of Mind. Indeed, Theory of Mind, the ability to attribute mental states to other people and to understand them shows a gradual development. It is possible to identify different levels of Theory of Mind. The first entails the ability to implicitly attribute intentions, mainly motor intentions, to others. The second level implies the capacity to explicitly reason about other people mental states (desires, beliefs, intentions, etc.). A third level implies the ability to reason about other people mental states concerning, in their turn, other people's mental states (e. g. "I know/believe/predict that John knows that Mary knows"). Accordingly, different kinds of Theory of Mind tests, such as the false-belief test, are usually run. Clements and Perner (1994), using an anticipatory looking paradigm, showed false belief understanding in 2 years and 11 month-old children; in Southgate et al. (2007), the age of false belief understanding was lowered to 25 months using the same experimental paradigm. Recently Buttelman, Carpenter and Tomasello (2009) carried out a study using an active helping paradigm. This study showed false belief understanding in 18 month-old infants. In these studies, children are not requested to explicitly and verbally reason about other people's intentions. Their helping behaviours and their eye gaze directions seem to suggest false belief understanding.

A false-belief task can also be explicit and verbal and it can test first and second order mental representations. Indeed, in the "Anne and Sally" test (Wimmer and Perner, 1983) the experimenter asks children about Anne's (false) belief or asks about what Sally knows that Anne knows. The former is a first-order mental representation test, it is passed by children around the age of 4 years; the latter is a second-order mental representation test and children are usually able to pass the test only after their 4th birthday. The use of irony is considered as a proof of a full Theory of Mind ability. In fact, many studies carried out with both typically and atypically developing children seem to suggest that the understanding of second-order mental representations is needed in order to acquire irony (Happé, 1993, 1995; Sullivan, Winner, & Hopfield, 1995; Winner, Brownell, Happé, Blum, & Pincus, 1998; Winner & Leekam, 1991). Although there is not a general agreement on the exact age at which children start to use irony, this is, beyond all doubt, a later achievement in language acquisition. According to some researchers (Demorest et al. 1983, 1984) children become competent ironists

at about 13 years of age. According to others (e. g., Harris & Pexman, 2003; Sullivan et al., 1995; Winner & Leekam, 1991; see Filippova and Astington 2010 for a review) children of 6 years of age can already comprehend some form of irony. As Filippova and Astington argue, this difference may be due to the fact that those studies looked for different aspects of irony understanding. Moreover, they might show evidence of a gradual development of irony comprehension. In any case, even the results attesting irony competence at six years of age are fully compatible with the claim that irony entails second-order mental states understanding. Indeed, results by Perner and Winner (1985) attest understanding of second-order mental states at around the age of six or seven years.

Very briefly, we can say that irony entails the ability to go beyond the propositional meaning of an utterance, which sometimes can be literally true and sometimes can be literally false, and to grasp a speaker's intended meaning through the recognition of a form of violation. In order to carry out this inferential process, a complex mindreading ability seems to be necessary. Indeed, psycholinguistic studies carried out in typically and atypically developing children verify the necessity of a second-order mindreading ability in order to produce and comprehend irony.

Irony is then a paradigmatic example of inferential communication. Studies on the development of irony understanding offer us some hints about the socio-cognitive mechanisms that are necessarily involved in the development of inferential abilities in language production and comprehension. Most of the studies on embodied language seem to still disregard the question of how this inferential process works during linguistic activity and where and how in the brain it is implemented.

## **2.1 Speaking is Acting**

In a recent article by Friedmann Pulvermüller (2012), the sketch of a neurobiological model of language is preceded by an introduction about semantic theories. Importantly, Pulvermüller introduces pragmatic concepts in the embodied language research. Indeed, the ideas of the philosopher Ludwig Wittgenstein are given plenty of room in this introduction. In particular, Wittgenstein's notions of "meaning as usage" and "word kinds" are presented. There are different kinds of meaning that lead to different kinds of words and, Pulvermüller says, each kind leads to the activation of a different area of the brain. So, for example, we have object-words, action-words or emotional words.

Semantic knowledge, in these word kinds, is coded in our brain respectively in terms of perception knowledge, action knowledge or emotional knowledge.

However, despite the interesting discussion of these wittgensteinian notions, the account of semantics that Pulvermüller proposes is completely describable according to the dictionary model of language. In fact, his account is grounded on the idea that semantics is made up of the binding of a word form and a kind of meaning knowledge. And that language comprehension is the act of connecting the word form to the right knowledge, i. e. to a pattern of neural activation. Pulvermüller does not really look at usages of words in speech act contexts, that was one of Wittgenstein main concerns and one of the most interesting aspects of his philosophical legacy. The problem of how intentions, background knowledge, context, etc. . . . , come together to construct meaning is not addressed by Pulvermüller nor by most of the other reserchers working in the embodied paradigm.

Boulenger, Hauk and Pulvermüller (2009) carried out a fMRI study on idiom comprehension, considered as examples of non-literal meaning. This study compared the comprehension of literal and non-literal sentences (idiomatic) containing action-related words. The authors found that the comprehension of both literal and idiomatic sentences containing action-related words led to somatotopic activation along the motor strip. These findings were further confirmed in a later study carried out by Boulenger, Shtyrov and Pulvermüller (2012) using a different technique (MEG – MagnetoEncephalography) that affords more temporal information about brain processes. Data from this second study revealed somatotopic activation of precentral motor systems during the processing of both literal and idiomatic sentences containing action-related words.

However, despite the fact that these studies take into consideration forms of non-literal meaning, they seem to be very far away from the goal of understanding inferential communication in real-life linguistic activity. Indeed, participants of both studies read sentences (e. g. “Pablo kicked the habit” and “Pablo kicked the ball”) on a computer screen, without any contextual information. This means that participants did not have to face any pragmatic task that could have triggered inferential understanding and, consequently, for example, a different modality of recruitment of the motor system. If we utter the sentence “Pablo kicked the habit” in a real-life conversation in order to talk, for example, about a friend that has stopped smoking, would the pattern of neural activation be exactly the same? We can hypothesize that, on the basis of our background knowledge, the idiom is interpreted as “Pablo stopped smoking” and the somatotopic

activation in the motor system could, thus, pertain to the action of smoking and not the action of kicking.

It is now possible to turn to another issue of pragmatics studies that seems to be undervalued in the embodied language researches when it might be very important in order to understand how language works. This issue concerns the definition of language as action. To speak is never just a mere neutral description of states of affairs. Speaking always implies the carrying out of both a physical and a social action. By using irony, we can ridicule or praise someone; with a declaration we can start a war, a love affair, or a hearing in the court; with words we can apologize, we can get married, we can name children or boats. And the list could go on infinitely because the social actions carried out by language are potentially countless. It is important to note that speaking is also an action in the physical sense. Indeed, speaking implies the movement of the oro-facial muscles and often of the hands, which can be involved in co-speech gesturing (or hands and co-sign mouthing in the case of sign languages).

Therefore, this should lead researchers to look at language as the performance of physical and social actions. Speaking is acting in a broader sense than just naming objects, actions or abstract concepts. By speaking, we always want to do something. In fact, many of the actions that make us human can only be carried out in language. Speaking implies some kind of background knowledge, goals and intentions; it implies physical movements and it has social effects. On the whole, non-linguistic intentional actions seem to share these very same features. And besides, linguistic activity entails communicative intentions, mainly not present in non-linguistic and non-communicative actions.

However, often linguistic actions are undervalued and what is taken into account is only the process that links a sign, i. e. a word form, to a meaning.

The definition of language as action has been widely discussed by philosophers of language like Austin and Wittgenstein. However, researches working in the embodied language paradigm, despite the fact they were greatly responsible for the discovery of empirical evidence in support of the claim that language is deeply grounded in the brain systems for action and perception, seem not to consider speaking as being an action itself. When I say “Pablo kicked the ball” or “Pablo kicked the habit” I have an intention and I expect my action to have an effect in the real world. And I presuppose that you share the knowledge with me that will allow you to understand what I am saying.

Imagine that I want you to hire Pablo in your company, but you do not agree with me because Pablo has been having trouble with alcohol. I come to your office and say: "Pablo kicked the habit". This utterance is sufficient to let you understand my request. Without a sophisticated and mutual recognition of intentions and beliefs, this linguistic exchange could not work. Furthermore, how could I perform this action of requesting without language? Humans, then, have a very complicated kind of action, linguistic actions. Hence, we should look at language from the same perspective we use to understand action.

This leads us again to the problem of the mindreading systems needed in order to understand action/language.

### **3 Comprehending Others' People Actions**

If speaking is acting (the speaker is performing an action and the addressee has to interpret the speaker's action), studies on action understanding can help us to clarify language production and comprehension. In particular, these studies could help us in the task of understanding how the mindreading ability is involved in the construction of meaning. How do we get inferential meaning out of literal sentences and what is the role of mindreading in the construction of inferential meaning?

Recently, many works have been devoted to the task of identifying the neural mechanisms that support our ability to understand other people mental states. This ability seems to be necessary for action understanding (see Frith and Frith 2006 for a review). In fact, as Frith and Frith argue (2006, 531), mental states determine actions.

Very often the inferential process of mentalizing is carried out automatically. This means that it does not entail conscious thought or deliberation.

Often, when we are involved in the task of understanding other people actions, implicit and automatic inferences are carried out in the Mirror Neuron System. However, simulations carried out in the Mirror Neuron System cannot always explain the full process of understanding others' goals and intentions (Frith and Frith, 2006; Mitchel, Macrae and Banaji, 2006). For example, as Mitchel, Macrae and Banaji argue (2006), motor simulation cannot explain long-term attitude. The question is still under debate. Despite the fact that mindreading seems to be a very important function, its neural implementation seems to be still controversial. In particular, while the role of the Mirror Neuron System is less controversial in order to understand motor intentions of familiar actions, the possibility of a different neural implementation is under consideration for

a more sophisticated form of mindreading that would allow for the understanding of non-familiar actions.

Following Brass *et al.* (2007), it is possible to say that we have two different accounts of the systems that allow us to interpret other's behaviours. According to one of them, based on the process of motor simulation, we understand others' actions by simulating them through the activation of the mirror neuron system. According to a second account, action understanding is realised by means of inferential processes implemented in non-mirror circuits of the brain (Brass *et al.*, 2007). The findings of Brass and colleagues (2007) support the idea that action understanding in novel and implausible situations is primarily mediated by an inferential interpretive system rather than the mirror system. Following the authors, an action is implausible if its goal is not obvious but required context-based inferencing. According to the authors, implausible action understanding activates a brain network involved in inferential interpretative processes that lack mirror properties (Brass *et al.* 2007). No differential activation was found in the mirror neuron system in relation to the contextual plausibility of observed actions.

Then, in this model the comprehension of implausible action is the result of a context-sensitive inferential process of mentalizing.

Turning again to the problem of language production and comprehension, what kind of mindreading mechanism is at work when we produce and comprehend linguistic actions? And in particular, what kind of mindreading mechanism is at work in the understanding of inferential communication (e. g. irony, jokes or the daily conversations such as the one previously discussed)?

In light of the findings of Brass *et al.* (2007), it is reasonable to hypothesize that in the understanding of inferential meaning in daily communication we also need a more complex and inferential form of mindreading that should be involved, being an integral part of it, in the dynamic process of the construction of meaning. It is plausible that this mechanism interacts with other mechanisms also involved in linguistic comprehension, such as the mechanism of motor simulation. These considerations push us to deepen our understanding of the role of contextual effects on language and action understanding. Furthermore, these considerations push us to reflect more on the role of these contextual effects on automatic mechanisms such as the mechanism of motor simulation. Only further empirical studies can help to clarify these issues.



## 4 References

- Attardo, S. (2000). Irony as relevant inappropriateness. [Article]. *Pragmatics*, 32(6), 793–826.
- Barsalou, L. W. (1999). Perceptual symbol systems. *Behavioral and Brain Science*, 22(4), 577–609; discussion 610–560.
- Boulenger, V., Hauk, O., & Pulvermüller, F. (2009). Grasping ideas with the motor system: semantic somatotopy in idiom comprehension. *Cerebral Cortex*, 19(8), 1905–1914.
- Boulenger, V., Shtyrov, Y., & Pulvermüller, F. (2012). When do you grasp the idea? MEG evidence for instantaneous idiom understanding. *Neuroimage*, 59(4), 3502–3513.
- Brass, M., Schmitt, R. M., Spengler, S., & Gergely, G. (2007). Investigating action understanding: inferential processes versus action simulation. *Current Biology*, 17(24), 2117–2121.
- Buttelmann, D., Carpenter, M., & Tomasello, M. (2009). Eighteen-month-old infants show false belief understanding in an active helping paradigm. *Cognition*, 112(2), 337–342.
- Carapezza, M., & Biancini, P. (in press). Language-game: calculus or pragmatic act?. In A. Capone, F. Lo Piparo, M. Carapezza (eds.), *Perspectives on Pragmatics and Philosophy*, Springer.
- Choi, S. (1988). The semantic development of negation: a cross-linguistic longitudinal study. *Child Language*, 15(3), 517–531.
- Clark, H. H., & Gerrig, R. J. (1984). On the pretense theory of irony. *Experimental Psychology General*, 113(1), 121–126.
- Clements, W., & Perner, J. (1994). Implicit understanding of belief. *Cognitive Development*, 9(4), 377–395.
- Colston, H. (2000). On necessary conditions for verbal irony comprehension. *Pragmatics and Cognition*, 8, 277–324.
- Demorest, A., Meyer, C., Phelps, E., Gardner, H., & Winner, E. (1984). Words speak louder than actions: Understanding deliberately false remarks. *Child Development*, 55, 1527–1534.
- Demorest, A., Silberstein, L., Gardner, H., & Winner, E. (1983). Telling it as it isn't: Children's understanding of figurative language. *British Journal of Developmental Psychology*, 1, 121–134.
- Filippova, E., & Astington, J. W. (2010). Children's understanding of social-cognitive and social-communicative aspects of discourse irony. *Child Development*, 81(3), 913–928.

- Frith, C. D., & Frith, U. (2006). The neural basis of mentalizing. *Neuron*, 50(4), 531–534.
- Gallese, V. (2008). Mirror neurons and the social nature of language: the neural exploitation hypothesis. *Social Neuroscience*, 3(3–4), 317–333.
- Gallese, V., & Lakoff, G. (2005). The Brain's concepts: the role of the Sensory-motor system in conceptual knowledge. *Cognitive Neuropsychology*, 22(3), 455–479.
- Gibbs, R. W., & Colston, H. L. (2007). *Irony in language and thought : a cognitive science reader*. New York; London: Lawrence Erlbaum Associates.
- Happé, F. G. (1993). Communicative competence and theory of mind in autism: a test of relevance theory. *Cognition*, 48(2), 101–119.
- Happé, F. G. (1995). The role of age and verbal ability in the theory of mind task performance of subjects with autism. *Child Development*, 66(3), 843–855.
- Harris, M., & Pexman, P. (2003). Children's perceptions of the social functions of verbal irony. [Article|Proceedings Paper]. *Discourse Processes*, 36(3), 147–165.
- Kumon-Nakamura, S., Glucksberg, S., & Brown, M. (1995). How about another piece of pie: the allusional pretense theory of discourse irony. *Experimental Psychology General*, 124(1), 3–21.
- Mitchell, J. P., Macrae, C. N., & Banaji, M. R. (2006). Dissociable medial prefrontal contributions to judgments of similar and dissimilar others. *Neuron*, 50(4), 655–663.
- Papeo, L., Rumiati, R. I., Cecchetto, C., & Tomasino, B. (2012). On-line Changing of Thinking about Words: The Effect of Cognitive Context on Neural Responses to Verb Reading. *Cognitiv Neuroscience*, 24(12), 2348–2362.
- Pulvermüller, F. (1999). Words in the brain's language. *Behavioral Brain Science*, 22(2), 253–279; discussion 280–336.
- Pulvermüller, F. (2002). *The neuroscience of language: on brain circuits of words and serial order*. Cambridge: Cambridge University Press.
- Pulvermüller F. (2010). Brain-Language Research: Where is the Progress?. *Biolinguistics*, 4, 2–3:255–288.
- Rizzolatti, G., Fogassi, L., & Gallese, V. (2001). Neurophysiological mechanisms underlying the understanding and imitation of action. *Nature Reviews Neuroscience*, 2(9), 661–670.
- Southgate, V., Senju, A., & Csibra, G. (2007). Action anticipation through attribution of false belief by 2-year-olds. *Psychology Science*, 18(7), 587–592.
- Sullivan, K., Winner, E., & Hopfield, N. (1995). How children tell a lie from a joke – The role of 2nd-order mental state attributions. *British Journal of Developmental Psychology*, 13, 191–204.

- Tomasello, M. (1999). *The cultural origins of human cognition*. Cambridge, Massachusetts: Harvard University Press.
- van Ackeren, M. J., Casasanto, D., Bekkering, H., Hagoort, P., & Rueschemeyer, S. A. (2012). Pragmatics in action: indirect requests engage theory of mind areas and the cortical motor network. *Cognitive Neuroscience*, 24(11), 2237–2247.
- van Dam, W. O., Rueschemeyer, S. A., Lindemann, O., & Bekkering, H. (2010). Context effects in embodied lexical-semantic processing. *Front Psychol*, 1–150.
- Wilson, D., & Sperber, D. (1992). On verbal irony. *Lingua*, 87(1–2), 53–76.
- Wimmer, H., & Perner, J. (1983). Beliefs about beliefs: representation and constraining function of wrong beliefs in young children's understanding of deception. *Cognition*, 13(1), 103–128.
- Winner, E., Brownell, H., Happé, F., Blum, A., & Pincus, D. (1998). Distinguishing lies from jokes: theory of mind deficits and discourse interpretation in right hemisphere brain-damaged patients. *Brain Language*, 62(1), 89–106.
- Winner, E., & Leekam, S. (1991). Distinguishing irony from deception – Understanding the speaker 2nd-order intention. *British Journal of Developmental Psychology*, 9, 257–270.
- Wittgenstein, L., & Anscombe, G. E. M. (1953). *Philosophical investigations = Philosophische Untersuchungen*. Oxford: Blackwell.



# Traces of Embodiment in Chinese Character Formation

## A Frame Approach to the Interaction of Writing, Speaking, and Meaning

Johann-Mattis List

École des Hautes Études en Sciences Sociales Paris  
Centre de recherches linguistiques sur l'Asie Orientale

mattis.list@lingpy.org

Anselm Terhalle

Heinrich Heine University Düsseldorf  
Institute for Romance Languages and Literature

terhalle@phil.hhu.de

Daniel Schulzek

Heinrich Heine University Düsseldorf  
Institute for Language and Information

schulzek@phil.hhu.de

### Abstract

In this paper, we develop a frame approach for modelling and investigating certain patterns of concept evolution in the history of Chinese as they are reflected in the Chinese writing system. Our method uses known processes of character formation to infer different states of concept evolution. By decomposing these states into frames, we show how the complex interaction between speaking, writing, and meaning throughout the history of the Chinese language can be made transparent.

## 1 Introduction

In this paper, we discuss the complex interaction of the written form, spoken form and meaning in Chinese. We show that conceptual processes such as metonymy or metaphor and the sensory-motor grounding of human conceptualization are reflected in Chinese character development. Our analysis is based on the modelling of conceptual processes by means of a frame-based approach to character formation.

After introducing the notion of *embodiment* and its role for language development and linguistic analysis, we point out some general properties of the Chinese writing system, i. e. Chinese character forms, their place in traditional sign models and principles of character formation. We then give a short introduction on how concepts can be modelled as recursive attribute-value structures called *frames*. The main section consists of a frame-based analysis of selected character formation processes which illustrate the different ways phonemic, graphemic, and semantic components interact.

## 2 Embodiment and language

The term *embodiment* refers to a number of partly overlapping theories whose common denominator is the claim that cognition requires the interaction of a body with the world (Wilson 2002, Ziemke 2003). The view we adopt in this paper is that abstract concepts evolve on the basis of concepts which arise from perception and action. This approach is taken by Barsalou (1999) who proposes that concepts are constructed from *perceptual symbols*, i. e. subsets of modal representations which are stored in long-term memory and reused symbolically to stand for objects in the world.

### 2.1 Conceptual development and language reconstruction

Lakoff and Johnson (1980) were the first of now many linguists (e. g. Gibbs 2003 and Steen 2010) to underline the fundamental role that metaphor plays in the construction of abstract concepts based on physical concepts. They postulate that systematic correlates between emotions (such as happiness) and more basic sensory-motor experiences (such as an erect body posture, which is supposed to be often concomitant with happiness) lead to the metaphorical understanding of the more abstract concept on the basis of the concept resulting from the perceptual experience (Lakoff 1980: 58). This conceptual relation is reflected in language where words like *up* and *down* stand for spatial concepts as well as for emotional states: *cheer up!*, *I'm feeling a bit down*, *we've had our ups and downs*.

Thus, the word *up* preserves information regarding the sensory-motor source concept which underlies the abstract emotional concept. The link, which allows the inference that there is a relation between the two concepts, is the fact that they are associated with the same sound chain [ʌp]. Moreover, the emotional concept became a meaning of *up* only recently, whereas the spatial meaning is close to that of the Indo-European etymon *\*upo* <under, from under> (Pokorny 1959).

Not all cases are phonetically and morphologically as transparent as *\*up*, which means that more reconstruction work concerning the *\*formal* part of the linguistic sign is necessary to be able to draw *\*conclusions* about the semantic side. The sound chain of the Latin word *\*capacitas* <ability> goes back to the Indo-European root *\*keh<sub>2</sub>p-* <to seize, to grasp> via Latin *\*capere* <to seize> – or to the non-laryngealized *\*kap-*, which cannot be excluded – (Georges 1998, Rix et al. <sup>2</sup>2011), and French [[ɛf] <boss, \* chief> stems back from Latin [kaput] <head> (Gamillscheg 1997, see Figure <sup>\*</sup> 1 and Figure 2), which in turn might be derived from the root of Latin *\*capere* as well (Vaan 2008).

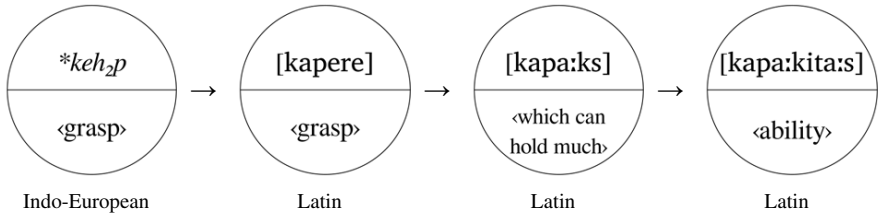

Fig. 1: Etymology of Latin *capacitas*.

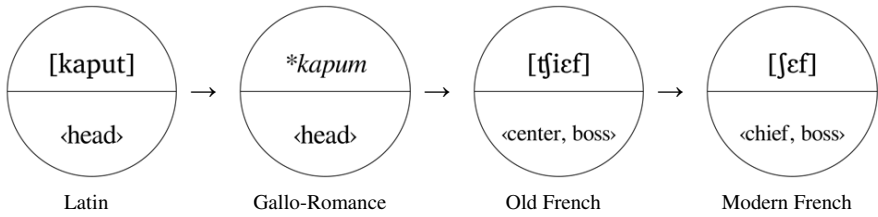

Fig. 2: Etymology of French *chef*

Independently of the morphological \* transparency, the genetic relation (or identity as in the case of \* *up*) between the sound chains can thus be seen as a trace of the \* sensory-motor grounding of the more abstract concepts <ability> and <boss> \* on the basic concepts <grasp> and <head>. This information about \* conceptual development is of interest for historical semanticists and \* cognitive scientists in search of linguistic evidence for embodiment.

However, reconstructing the history of a word, i. e. regressing its sound chain back to earlier forms, leads to a sound chain which is no less arbitrary with respect to the concept it designates than the word itself. Tracing back the evolution of French *chef*, we obtain the Latin word *caput*. Its sound chain does not tell us anything about its meaning which is something we have to investigate at the same time.<sup>1</sup>

## 2.2 Traces of embodiment in Chinese character forms

As we have seen, reconstructing the form of a linguistic sign does not automatically provide knowledge about its meaning. This is different with the Chinese writing system.

<sup>1</sup> Our anonymous reviewer points out that the *-ut* ending does contain information about gender, declension or number, and thus provides semantic content. However, this does not alter our argument because *-ut*, as a linguistic sign, is as arbitrarily linked to its meaning as *cap-*.

Chinese characters consist of 1) the character meaning, 2) the character reading, i. e. a sound chain, and 3) the (written) character form. Reconstructing the evolution of the character form does not lead us to a collection of brush strokes related arbitrarily to any kind of concept, but to an iconic image character, to a representation of the concept originally designated by the form.



Fig. 3: Development of the Chinese character forms for 'chief, first' and 'fish'.

Consider the Chinese character forms for the concepts 'chief, first' and 'fish' (*shǒu* 首 and *yú* 魚, see Figure 3). Tracing back their evolution, we obtain less abstract images and end up with the source concept of 'chief' which is 'head' and for 'fish' which is, not surprisingly, 'fish'. The abstract concept 'chief, first' is grounded on the physical, bodily concept 'head' whereas 'fish' is not grounded on another basic concept as it is, in itself, a concept with physical, visible and touchable instantiations which are directly perceivable by sensory-motor means.

Thus, the successful reconstruction of the Chinese character form directly provides the concept associated with it. Of course, we do not deny that even the interpretation of the underlying image is subject to a certain arbitrariness. In the case of Chinese *shǒu* 首, for example, it cannot be completely ruled out that the underlying image depicts something else than a head; and even if we admit that it shows a head the question arises as to what kind of head it is. However, because of their form representing character, these signs are less open to interpretation than are non-onomatopoeic sound-based signs: assuming that we do not have any additional information, an icon provides more



clues than a sound chain. This makes the Chinese writing system attractive for the study of embodiment.

### 3 Chinese characters

The Chinese writing system (CWS), as we know it today, is famous for its structural properties reflected by a complicated interaction of phonetic and semantic elements.<sup>2</sup> Since the Chinese characters can be divided into elements carrying phonetic as well as semantic functions, it is sometimes called a ‘semanto-phonetic writing system’ (*yìyīn wénzì* 意音文字, cf. in Zhōu 1998: 60), yet this characterization exaggerates the actual power of Chinese characters to display phonetic information in a transparent way: Most of the “phonetic” characteristics of the CWS are relics of the processes of character formation which, as they took place asynchronously, were always characterized by a complex interaction between the Chinese language spoken at different times of its history, the sociocultural background of those people who created the characters, and general patterns of reasoning and conceptualization.

#### 3.1 General characteristics of the Chinese writing system

From a phonetic perspective, the CWS can be characterized as a *syllabic writing system*, since every character represents a syllable of the Chinese language. From a semantic perspective, on the other hand, it is a *morphemic writing system*, since the majority of all characters represents a minimal semantically meaningful unit of the Chinese language. In contrast to the dichotomic structure of alphabet systems, a Chinese character therefore has a trichotomic structure, since it can be characterized by its *form*, its *meaning*, and its *reading* (List 2009). Thus, the Chinese character *cǎi* 采 <to pluck> is defined by its written form 采, its meaning ‘to pluck’, and its reading [ts<sup>h</sup>ai<sup>214</sup>] (see Figure 4). Given this specific structure, we prefer the term *morpheme-syllabic writing system* (Chao 1968: 102) over the above-mentioned term *semanto-phonetic writing system*, since this term more closely reflects the concrete units of the semantic and the phonetic domain that are referred to by a Chinese character.

---

<sup>2</sup> The use of the term “phonetic” follows the terminology that is used in the mainstream discussions on the topic. Our anonymous reviewer, however, is surely right in stating that it is rather “morphological” than strict “phonetic identification” we are dealing with here.

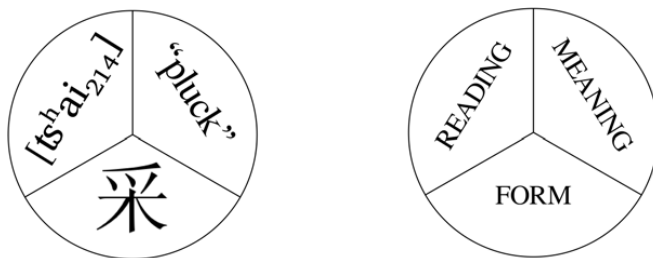

Fig. 4: The trichotomic structure of Chinese characters.

### 3.2 External and internal structure of Chinese characters

An important aspect of Chinese character forms is their two-fold structure: Character forms can be analysed with respect to their *external* and their *internal structure* (List 2008: 45 f.). Here, *external structure* refers to the formal aspects of the way the forms are built, i. e. the number, the order, and the direction of strokes. *Internal structure* refers to the motivation underlying the creation of the forms. While an analysis with respect to the external structure is strictly synchronic, an analysis of the internal structure is always done with respect to the diachronic dimension of a character.

As an example, consider again the character *cǎi* 采 <to pluck> (see Figure 5, middle). Based on its external structure one can divide the form into a sequence of eight different strokes (see Figure 5, left). The internal structure, on the other hand, can only be understood when going back in time and looking at the oracle bone version of the form, which dates back to around 1000 BC (see Figure 5, right). Here, one can see a hand which plucks some kind of fruit from a plant.<sup>3</sup> Judging from the old version of the character form alone, the pictographic motivation might not be too obvious. But both the picture for <hand> and the picture for <fruits on a plant> are reflected in other old character forms as well, so there can be little doubt that the original motivation for the creation of the character form was to depict the process of grasping.

### 3.3 Basic types of Chinese character formation

By now, it should have become clear that – in contrast to many alphabetic systems – the formation of the Chinese character forms was not accomplished ad hoc, but instead took a certain amount of time, whereby many character forms were created during

<sup>3</sup> This is, of course, an overstatement, since we cannot see an action on a static picture, but have to infer the action from what we see.



Fig. 5: Chinese character form (middle) with its internal (right) and its external (left) structure.

different time periods. The way new character forms were derived remained, however, rather stable during the history of the CWS.

Based on the internal structure of the form, one can roughly distinguish three different types of character forms: (1) *semantic characters*, i. e. characters whose formation was only semantically motivated, (2) *phonetic characters*, i. e. characters whose formation was purely phonetically motivated, and (3) *semanto-phonetic characters*, i. e. character forms whose formation was both semantically and phonetically motivated.<sup>4</sup> As an example for the first formation type, consider, again, the character *cǎi* 采 <to pluck>. As was shown in the preceding paragraph, its form was originally a pictogram of a hand grasping some kind of fruit. Therefore, the motivation was purely semantic. The original form never provided any hint regarding the pronunciation of the word which it was supposed to refer to.<sup>5</sup> As an example for the second formation type, consider the character *kù* 酷 <cool>. This is a recent borrowing from English, pronounced as [ku<sup>51</sup>] in Chinese, and the Chinese reflection of the word *cool* in the modern sense of *being Cowboy-like* and *calm*. Since the Chinese originally did not have a written representation for this loan word, they chose to use another character with an identical reading in order to reflect this specific word, resulting in a pure phonetic motivation for this specific use of the character.<sup>6</sup> As an example for the third formation type, which combines phonetic and semantic motivation, consider the same character *kù* 酷 with its original meaning <cruel>. Its form can be divided into the two elements *yǒu* 酉 <bottle with liquid> and *gào* 告 <to tell>, where the first probably serves as a semantic trigger for the original meaning of the word (“ripe”), while the second has a phonetic function,

<sup>4</sup> This is a very rough classification of Chinese characters, for a more refined classification, see, e. g., List (2008).

<sup>5</sup> At least we don't have positive evidence for a phonetic function.

<sup>6</sup> This is a bit of an oversimplification, since in China the selection of characters to represent words that have so far no written representation is always driven by certain semantic considerations.

giving a hint to the pronunciation of the word (cf. Old Chinese \*k<sup>s</sup>uk for 告 vs. \*k<sup>h</sup>uk for 酷).<sup>7</sup>

Based on this rough distinction between the three different types of character forms, one type of *primary* and two types of *secondary character formation* can be distinguished. *Primary character formation* was often pictographic or ideographic. *Secondary character formation*, i. e. the formation of character forms based on already existing ones, was either based on *phonetic borrowing* or on *semantic reinforcement*.<sup>8</sup> As an example, consider the character *xiàng* 象 <elephant>. The formation type of its character form is primary, since it originally was semantically motivated, as a pictogram of an elephant, and one can therefore display the relations between meaning, reading and form of the character as illustrated in Figure 6 (left). Yet, already very early on, the Chinese used this character form not only for <elephant>, but also for <image>, which was pronounced in the same way as the word for elephant. Lacking a character form for such an abstract concept, they simply took the Chinese character form for <elephant>, and assigned it a different meaning. Therefore, the second meaning of the form 象 is purely phonetically motivated, and a new character was formed by means of borrowing. The relation between reading, form, and meaning can be displayed as illustrated in Figure 6 (middle). In even later times, the Chinese apparently did not feel quite comfortable with having two meanings expressed by a single character form, and so they created a new character for <image>. This was done by adding a semantic element to the character form, which would distinguish <elephant> from <image>. Taking the form of the character *rén* <human> as an additional semantic element, a new character was built by means of semantic reinforcement. In contrast to the previous character forms, the new form has a double reference to both the reading and the meaning of the character, as illustrated in Figure 6 (right).

#### 4 Frames

In cognitive sciences, the term *frame* is used for several kinds of meaning representations of situations or objects. What all approaches have in common is that concepts are not considered as atomic units, but rather as highly structured entities. Barsalou (1992) develops his frame theory in contrast to meaning representations by feature lists, as

<sup>7</sup> Old Chinese readings follow Baxter & Sagart (2011).

<sup>8</sup> This is a very rough description of the basic types of Chinese character formation. For a more detailed account on Chinese character formation, see especially Qiú (1989).



Fig. 6: Basic types of character formation.

they have been used in early cognitive semantics. Barsalou passes criticism on decomposing concepts in unordered samples of features because “people do not store representational components independently of one another” (Barsalou 1992: 27). Instead, Barsalou points to evidence from several experiments that human cognition is based on attribute-value structures: The attributes describe general properties or dimensions of the object or category being represented, and the values are specifications of the attributes. From this point of view, the values correspond to features in feature lists, while the attributes represent the relations between these features and the represented object or situation. According to Barsalou, frames are recursive in that values and attributes are represented in further frames. Thus, it is almost impossible to reconstruct a “complete” frame. Rather, we will always refer to partial frames in the following, i. e. we will only point out those attributes that are currently relevant.

Petersen (2007) uses directed graphs to model frames in the sense of Barsalou. In frame graphs, the arcs correspond to attributes and the nodes correspond to values (see Figure 7 for an example). The central node of the frame is marked by a double border. It designates the object or category being represented in the frame. Mathematically, attributes correspond to partial functions mapping values to values. As a consequence, attributes are right-unique, i. e. every attribute is specified by exactly one value. Because of their right-uniqueness, attributes are predestined to be named with functional nouns in the sense of Löbner (2011) who distinguishes four basic types of nouns, depending on two binary features: relationality and uniqueness. Functional nouns are inherently unique and inherently relational, because their reference to a possessum is uniquely given once a possessor argument is saturated. Typical examples are nouns like *mother* or *nose* that identify their referent uniquely according to a possessor: a mother is always a mother of someone, and everyone has exactly one [biological] mother. Anal-

ogous statements are the case for the noun *nose*. Due to their inherent relationality functional nouns mostly occur in possessive constructions (cf. Löbner 2011: 14–18).

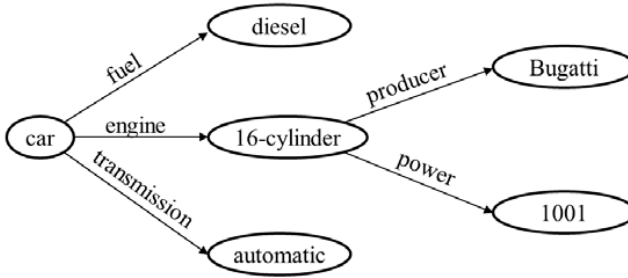

Fig. 7: car frame as a directed graph.

Löbner (2005) argues that functional nouns are verbalizations of attributes in frames such that concepts can be decomposed in terms of functional nouns. On this basis, we are able to identify the range of values an attribute can take. Building on Guarino (1992), we distinguish between the relational and the denotational interpretation of functional nouns. The relational interpretation refers to the relation that links the possessor somehow to the possessum. The denotational interpretation, however, is the referent to a certain possessum according to a given possessor. In mathematical terms, relational nouns are functions, where the relational interpretation corresponds to the mapping rule of the function and the denotational interpretation to the value the function takes according to a given argument. For instance, the relational interpretation of the concept *mother* in the NP *Paul's mother* is the mapping rule “*x is mother of y*”, while the denotational interpretation is the referent of the NP.

Due to their twofold interpretation, functional nouns are able to designate attributes as well as their values: attributes correspond to the relational interpretation of functional nouns and values to their denotational interpretation. For instance, the functional noun *motor* describes the attribute <motor> in Figure 4 as “*value x is the motor of the object y*” while its denotational interpretation makes it possible to refer to the motor of the object itself. Thus, the values of an attribute have to be hyponyms of the denotational interpretation of the functional noun with which the attribute is named. This interpretation of attributes is in line with Barsalou who postulates that “[v]alues are subordinate concepts of an attribute” (Barsalou 1992: 31). A special case is attributes in verb frames that contain information about theta roles. Their range is determined by

selectional restrictions of the verb. We will mark value ranges in verb frames by naming the range on top of the value node (see Figure 8 for an example).

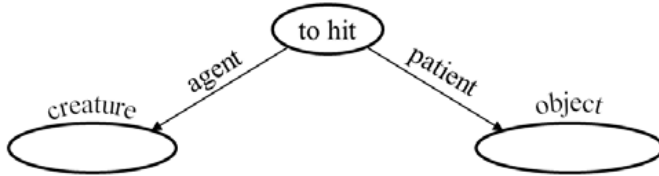

Fig. 8: Frame of the verb to hit.

## 5 A frame model of character formation and concept evolution

Since we assume that frames are the general format of human cognition, frame theory offers a tool to describe stages in concept evolution that are reflected in Chinese character formation. In the following, we discuss three examples which illustrate how the sensory-motor grounding of human conceptualization is reflected in the formation of new Chinese characters.

The first example illustrates the development of the character *cài* 菜 <vegetable>. Originally, there was no specific character for this concept, and therefore the character *cǎi* 采 <to pluck> was used to designate the concept. The problematic polysemy was only later resolved, and the character form was modified by adding the form of the character *cǎo* <grass> on top. The frame of the <plucking action> contains a theme argument which takes a kind of plant as its value. On the linguistic surface, <to pluck> could be expressed by the word [ $*m-s^{\uparrow}rə?$ ], which is the way the word was pronounced around 600 BC (Baxter & Sagart 2011). Since a vegetable is something that is typically plucked when it is ripe, it is a possible value for the theme argument. Chinese word formation around 600 BC allowed the derivation of verbs by prefixation and suffixation (Sagart 1999). One common process involved the suffix [ $*-s$ ] which provokes a nominalization of verbs (Sagart & Baxter 2011): adding [ $*-s$ ] to [ $*m-s^{\uparrow}rə?$ ] yields the word [ $*m-s^{\uparrow}rə?-s$ ] which has the meaning <plucked (things)>.

Over time, the meaning <plucked (things)> developed into the more specific meaning <vegetable>. The metonymical relationship between <to pluck> and <vegetable> and the formal relationship between the character reading associated with <to pluck> and the one associated with <vegetable> resulted in the use of the same form for <to pluck>

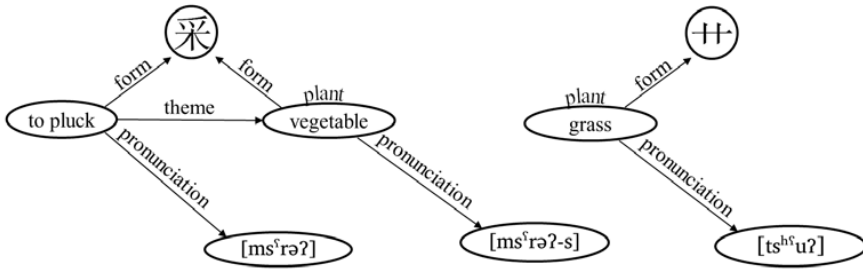

Fig. 9: Frames for <to pluck a vegetable> and <grass>.

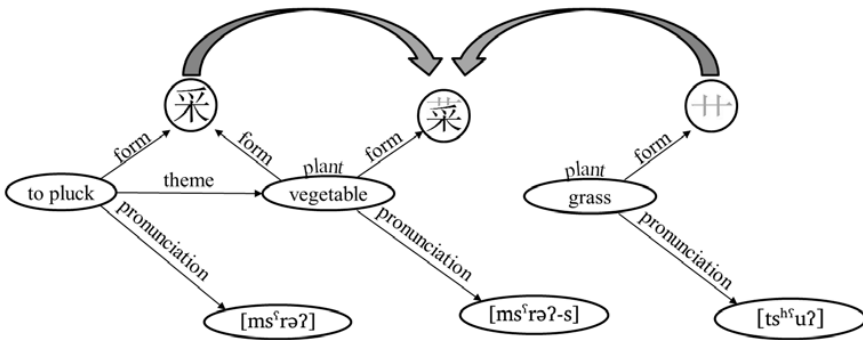

Fig. 10: Creation of a new character for the concept <vegetable>.

and <vegetable> (see Figure 9). Problematic polysemies, e.g. polysemies concerning concepts which are part of the same frame, tend to be resolved by the speakers (Blank 1997: 357). To distinguish the concepts on the linguistic surface, a new form for the concept <vegetable> was created (see Figure 10). The concepts <vegetable> and <grass> are instantiations of the class <plant>. To solve the polysemy, the form for <grass> is added to the form for <pluck>. Thus, a character form for <vegetable> is created by grounding the concept on the metonymically related motor action <to pluck> and subsequently, the ambiguity of the character form for <pluck> is resolved.

The second example illustrates the development of the form of the character *qū* 娶 <to marry (a woman)> which is built as a combination of *qǔ* 取 <to grasp> and *nǚ* 女 <woman> (see Figure 11). The systematic correlates between the symbolic, i.e. abstract, act of marriage and the sensory motor experiences accompanying it, i.e. taking the bride to another place, as opposed to *jià* 嫁 <(leaving the family) to marry (a man)>, result in the grounding of the symbolic act on the bodily actions. This is reflected in



the combination of the characters for *qǔ* 取 <to grasp> and *nǚ* 女 <woman> to a new character which stands for <to marry>.

The frame of a typical grasping action contains the theme argument which typically has objects as values. The form of its character *qǔ* 取 is an abstraction of a picture showing a hand grasping an ear. The pronunciation sounded approximately like [<sup>h</sup>\*tsʰoʔ] (Baxter and Sagart 1999).<sup>9</sup> The theme argument allows many kinds of values, for instance women. The concept <woman> is represented by *nǚ* 女, a form which originally depicted a person sitting with the legs to the side. When the class of the theme argument is <woman>, the whole frame represents the bodily action <to grasp a woman>. The concept <to grasp a woman> is more specific than the non-saturated concept <to grasp>, i. e. the upper-type concept of the theme attribute is substituted by a subsumed concept of the original concept, so that the range of the attribute is reduced (see Figure 12).

The lexicalization of this new, specialized meaning resulted in a situation where the reading [<sup>h</sup>\*tsʰoʔ] and the associated form 取 had two taxonomically related meanings. This problematic polysemy was resolved by merging the characters *qǔ* 取 <to grasp> and *nǚ* 女 <woman> to create the new form *qǔ* 娶 which stands for the concept <to marry (a woman)>, an abstract concept grounded on the sensory motor concept <to grasp a woman> (see Figure 13).

The third example illustrates the creation of the character *xiǎng* 想 <to think> which – judging from its derivation as a compound of the characters *xiāng* 相 <to observe> and *xīn* 心 <heart/mind> – can be metaphorically understood as <to observe with one’s heart/mind>. This means again that an abstract concept is put down to a sensory motor concept which results directly from perceptual experience. The metaphorical process consists of a modification of the attribute-value structure of the concept <to observe> – which typically takes as instrument the concept <eye> (see Figure 14) – as the instrumental argument is saturated by the concept <heart>. As the argument saturation violates the original concept structure, no literal understanding is possible, so that the resulting concept is necessarily abstract.

In the abstract concept, <heart/mind> figures as the value of the instrumental argument. The reading that represented the concept <observe with one’s heart/mind>, i. e. <to think>, was derived from the pronunciation of the more general concept <to observe>: [<sup>h</sup>\*saŋs] was changed to [<sup>h</sup>\*saŋs-ʔ > \*saŋ-ʔ], meaning <to think> (Schuessler

<sup>9</sup> As the anonymous reviewer pointed out, this is the practice of “cutting off the ears of an enemy and hanging them on a ritual girdle as a trophy, later called *guó* 馘.”

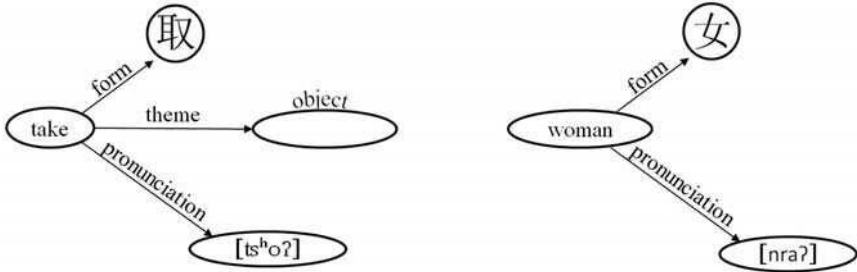

Fig. 11: Frames of «to grasp» and «woman».

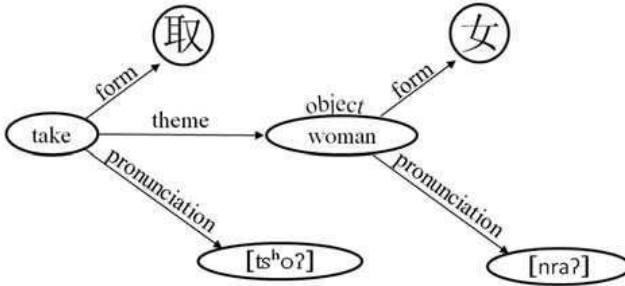

Fig. 12: Frame of the more specific concept «to grasp a woman».

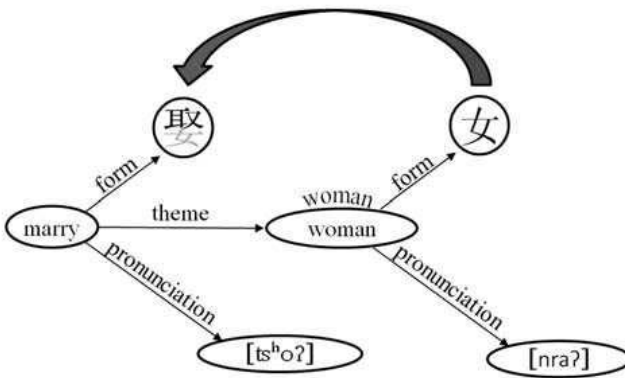

Fig. 13: Creation of a new character for «to marry (a woman)».

2007: 46 f.). The polysemy of the form which now stood for <to observe> and <to think> was disambiguated by integrating the character form for *xīn* 心 <heart/mind> into the character form for *xiāng* 相 <to observe> (see Figure 15).

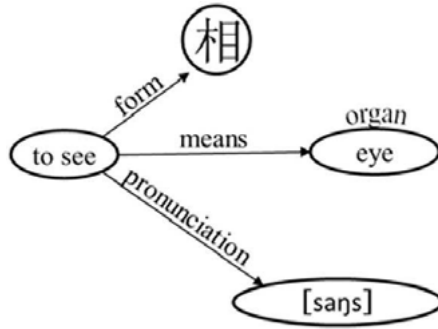

Fig. 14: Frame of <to see>.

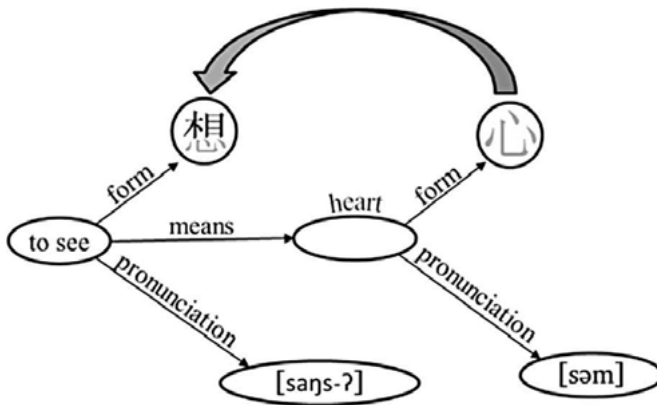

Fig. 15: Creation of a character for <to think>.

## 6 Summary

The processes of Chinese character formation reflect different states in concept development. They are well documented throughout the history of Chinese. Thus, the Chinese language offers rich possibilities to study concept evolution. Frame theory offers a tool for decomposing these different states in concept evolution in a cognitively adequate

way. Therefore, a frame approach may shed new light on concept development by analysing the interaction between writing, speaking, and meaning. In this paper, we demonstrated how frames can be used to model and investigate such different instances of concept evolution as metonymy, argument saturation, and metaphora. At the current state, our work remains exploratory, yet we are confident that the method provides a promising starting point for future research.

## 7 Acknowledgements

We would like to thank Liane Ströbel and the anonymous reviewer for their helpful advice and comments. Furthermore, we would like to thank the participants of the workshop on “Sensory-motor Concepts in Language and Cognition” (November 2011, Düsseldorf) for the fruitful discussion of our approach.

## 8 References

- Barsalou, L. W. (1992). Frames, concepts, and conceptual fields. In A. Lehrer & E. F. Kittay (Eds.), *Frames, fields, and contrasts* (pp. 21–74). Hillsdale, NJ: Lawrence Erlbaum Associates.
- Barsalou, Lawrence W. (1999). Perceptual symbol systems. *Behavioral and Brain Sciences*. 22, 577–660.
- Baxter, W. H. and Sagart, L. (2011). Baxter-Sagart Old Chinese reconstructions. Online at <http://www.webcitation.org/6hHSGTysV>.
- Blank, A. (1997). *Prinzipien des lexikalischen Bedeutungswandels am Beispiel der romanischen Sprachen* [Principles of lexical meaning change using the example of the Romance languages]. Tübingen: Niemeyer.
- Chao, Y. (1968). *A grammar of spoken Chinese*. Berkeley, Los Angeles, and London: University of California Press.
- Gamillscheg, E. (1997). *Etymologisches Wörterbuch der französischen Sprache* [Etymological dictionary of the French language]. Winter: Heidelberg.
- Georges, K. E. (1998). *Ausführliches lateinisch-deutsches Handwörterbuch* [Extensive Latin-German concise dictionary]. Unveränderter Nachdruck der 8. verb. und verm. Auflage (Reprint der Ausgabe Hannover: Hahnsche Buchhandlung 1913–1918). Online at: <http://www.zeno.org/Georges-1913/>.

- Gibbs, R. W. (2003). Embodied experience and linguistic meaning. *Brain and Language*, 84, 1–15.
- Guarino, N. (1992). Concepts, attributes and arbitrary relations: some linguistic and onto-logical criteria for structuring knowledge bases. *Data & Knowledge Engineering*, 8(3), 249–261.
- Lakoff, G. and Johnson, M. (1980). *Metaphors we live by*. Chicago: University of Chicago Press.
- List, J.-M. (2008). *Rekonstruktion des Mittel- und Altchinesischen* [Reconstruction of Middle and Old Chinese]. Magister Thesis: Freie University Berlin. PDF: <http://hprints.org/docs/00/74/25/52/PDF/list-2008-magisterarbeit.pdf>.
- List, J.-M. (2009). Sprachvariation im modernen Chinesisch [Language variation in modern Chinese]. *CHUN – Chinesischunterricht*, 24, 123–140.
- Löbner, S. (2005). Funktionalbegriffe und Frames – Interdisziplinäre Grundlagenforschung zu Sprache, Kognition und Wissenschaft [Functional nouns and frames – Basic interdisciplinary research on language, cognition and science]. In Alfons Labisch (Hrsg.), *Jahrbuch der Heinrich-Heine-Universität Düsseldorf 2004* (pp. 463–477). Düsseldorf: Heinrich-Heine-Universität.
- Löbner, S. (2011). Concept Types and Determination. *Semantics*, 28, 279–333.
- Petersen, W. (2007). Representation of Concepts as Frames. In Latvijas Universitate (Eds), *The Baltic International Yearbook of Cognition, Logic and Communication* (pp. 151–170). Manhattan KS: New Prairie Press (3).
- Pokorny, J. (1959–1969). *Indogermanisches etymologisches Wörterbuch* [Indo-European Etymological Dictionary]. 2 volumes. Bern/Munich: Francke.
- Qiú Xīguī 裘錫圭 (1988). *Wénzìxué gǎiyào 文字學概要* [Foundations for the investigation of writing systems]. Běijīng 北京: Shāngwù 商.
- Rix, H., Kümmel, M., Zehnder, T., Lipp, R. and Schirmer, B. (2001). *Lexikon der Indogermanischen Verben* [Lexicon of the Indo-European Verbs]. Reichert: Wiesbaden.
- Sagart, L. (1999). *The roots of Old Chinese*. John Benjamins: Amsterdam, Philadelphia.
- Schuessler, A. (2007). *ABC dictionary of Old Chinese*. University of Hawai'i Press: Honolulu.
- Steen, G. J., Dorst, Alette G., Herrmann, J. Berenike., Kaal, Anna, Krennmayr, Tina, and Pasma, Trijntje (2010). *A method for linguistic metaphor identification: From MIP to MIPVU*. Amsterdam/Philadelphia: John Benjamins.
- Vaan, M. de (2008): *Etymological Dictionary of Latin and the other Italic Languages*. Brill: Leiden/Boston.

Wilson, M. (2002). Six views of embodied cognition. *Psychonomic Bulletin & Review*. 9(4), 625–636.

Zhōu Yǒuguāng 周有光 (1998). *Bǐjiào Wénzìxué Chūtàn* 比文字初探 [Introductory investigations on the comparison of writing systems]. Shànghǎi 上海: Yǔwén 文.

# Motion and Emotion

## The application of sensory-motor concepts to the representation of emotion in literature

Wolfgang G. Müller  
Friedrich-Schiller-Universität Jena  
Philosophische Fakultät

womu@gmx.de

### Abstract

This article attempts to relate to literature insights on the role of sensory and motor processes as essential constituents of cognition. It concentrates on the representation of emotion. The starting-point of the investigation is the fact that the representation of emotion in literature is – analogous to emotion in actual life – essentially constituted by motion and other physical or physiological manifestations. The investigation is supported by cognitive research and by neuroscientific research concerning the interdependence of emotion and motion. Evidence is adduced that emotional experiences are in a great quantity of literary texts represented as cognitive experiences with a strong participation of kinesthetic activities of the body.

Keywords: embodied cognition, emotion, motion, facial feedback, body metaphors

## 1 Introduction

Cognitive science has recently had such a strong impact on literary studies that one can speak of a cognitive revolution in the scholarly treatment of literature (Stockwell, 2002). The new concept of embodied cognition or grounded cognition, which accords the body a central role in shaping the mind (Wilson 2002, Barsalou: 2008, 2010), has, however, not yet found reverberations in literary studies. Embodied cognition is an extraordinarily wide concept. It means that the areas in the brain which activate the body and those which are involved in processing reason and linguistic meaning work interdependently. (Wilson, 2002, Mahon/Caramazza, 2008) In fact, an embodied theory of meaning seems to take shape which relates the meaning of words and sentences to bodily action. (See for instance Glenberg and Paschak, 2002)

The present article<sup>1</sup> is a new departure in that it attempts to relate to literature insights on the role of sensory and motor processes as essential constituents of cognition.

---

<sup>1</sup> I am indebted for valuable help and inspiration to my Jena colleagues Doreen Triebel, Dirk Vanderbeke and Oliver Bock. For whatever may be open to criticism in this study they are not responsible.

(Pezullo et al., 2011) The notion of sensory-motor processes is comprehensive, since it includes, on the one hand, gestural, facial aspects and other movements of the body, and, on the other hand, phenomena such as smelling, tasting and hearing. It is not always possible to treat these processes separately. The following contribution concentrates on emotion, which has been a quite prominent topic in cognitive studies for the last two decades. (Hogan, 2010, p. 237) It attempts to show that writers of fictional literature seem to have had a notion of embodied cognition long before the term was created. A basis for applying sensory-motor concepts to literature as a product of the imagination is that “imagining and doing use a shared neural substrate” (Gallese/Lakoff, 2005, p. 456), i. e. when one imagines seeing something, the same parts of the brain are used as when one actually sees. Or when we imagine that we are moving, some of the same parts of the brain are used as when we actually move. Movement, perceived on a screen or represented in a text, may cause cognitive processing analogous to real-life movement. This notion can even be extended to the use of metaphors. It has been shown that not only actual and imagined physical activities, but also physical events evoked in metaphors (Lakoff/Johnson, 1999, Schrott, Jacobs, 211) and idioms (Boulenger, Hauk, Pulvermüller, 2008) can be related to the motor cortex. The whole development in philosophy and psychology from Descartes’ dualism of *res cogitans* and *res extensa* to modern views of the interconnectedness of body and mind in Antonio Damasio’s reference to the “embodied mind” (Damasio, 1984, 1999) or Matthew Ratcliffe’s understanding of feelings as “bodily states” (Ratcliffe, 2008), which provides a cultural context for recent advances in cognitive science, cannot be treated within the frame of this article. If certain developments in the philosophy and psychology of feeling lead to concepts which come close to what is called embodied cognition in cognitive science, this contribution will discuss literature as another significant area of cultural production which can be related to the context of embodied cognition.

## 2 Motion and Emotion

The starting-point of the following investigation is the fact that the representation of emotion in literature is – analogous to emotion in actual life – essentially constituted by motion and other physical or physiological manifestations. The etymology of the word is already significant. *Emotion* is derived from the French verb *émouvoir*, which is based on Latin *emovere* – in the Latin verb the preposition “e” means “without”/“out of” and *movere* means “move”. The connection of the phenomenon of emotion with motion



is ubiquitous in general language use, as the following randomly chosen metaphorical words and phrases show: “Gefühlsbewegung”, “revulsion of feeling”, “he fell in love”, “he fell into a depression”, “his heart started pounding when he saw her”.

Before starting our investigation, at least one piece of evidence from neuroscience for relating emotion and motion will be adduced to support our procedure by cognitive research. A team of researchers from Cambridge and Berlin made experiments on 18 persons, using magnetic resonance imaging to compare brain activation evoked by emotion words to that evoked by face- and arm-related action words. (Moseley, 2011) The result was that emotion words evoked activity in the motor brain systems. That means that emotion words activate the motor system in a way comparable to action words. So the attempt to correlate emotion and motion is corroborated by findings of neuroscience. For what holds true for actual reality can also be taken granted for imagined reality.

If we look at the representation of emotion in literature, we notice that it is, as is the case in actual reality, essentially constituted by motion and other physical or physiological manifestations. This holds true for visual art, too, as Edvard Munch’s painting “The Scream” shows.



Edvard Munch, *The Scream* 1893, National Gallery, Oslo

The hands of the screaming person are elongated and pressed tightly to the head. The mouth is wide open; so are the eyes, empty and unfocussed. The person is not actually in motion. The painting shows a face freezed with horror, which is the result of a movement, which is also reflected in the landscape. Munch's work is an outstanding example of the visual representation of embodied emotion. However, we must be aware of the fact that the painting is a work of art, of great art at that, and not what cognitivists would normally study. It transcends what is accessible to scientific experiments. But it is based on a principle on which many modern scientific theories of emotion are founded, namely that emotion is largely manifested in the body.

### 3 Facial Feedback in Narrative Prose

Textual analysis will begin by examining the representation of facial and other physical activity in narrative prose in relation to emotion. Cognitivists like Adelman and Zajonc interested in the phenomenon of emotion have emphasized "the role of emotional facial action in the subjective experience of emotion" (Adelman, 1989, p. 249). Adelman avoids 'the convention of referring to emotional facial action as "expression" since this term imposes an a priori theory, implying that emotional facial action (facial efference) has its major role in the manifestation of internal states.' (Adelman, 1989, pp. 249–250). While I agree with Adelman and Zajonc in avoiding subjectivist and expressionist theories, I take the liberty of using, at times, the term "facial (or bodily) manifestation" rather than "facial efference" ("efferent", 'carrying or conducting outwards from a part or an organ of the body, esp. from the brain or spinal cord').

Before looking at the representation of facial manifestation in literature, attention will be drawn to a famous experiment carried out by Fritz Strack (1967) which is relevant to our argument. This is the so-called *pen experiment* which proves the facial feedback hypothesis from a scientific perspective. Subjects had to hold a pen in their mouth in ways that either inhibited or facilitated the muscles usually associated with smiling. Holding a pen with the teeth only was considered a facilitating condition since it involved the muscles active in smiling; holding a pen with the lips only was considered an inhibiting condition, since it did not involve or, rather, inhibited the muscles associated with smiling. Subjects who had the pen between their teeth showed more intense humour responses, when cartoons were presented to them, than subjects who had the pen between the lips. The question of the quality of the response – affective or cognitive – cannot be discussed here. (See Dem 1967.)

Narrative texts in which a great amount of bodily and facial activity is represented are novels of the Thirties and the Forties of the last century (Dashiell Hammett, Raymond Chandler, Ernest Hemingway etc.), which I some time ago termed the behavioristic novel (Müller 1981). In this kind of narration the representation tends to leave out internal description and concentrate on outward physical manifestation, i. e. on what cognitivists call facial and bodily feedback. Here is an example from Hammett's novel *The Glass Key* (1931):

- (1) When he [Ned Beaumont] rose from the telephone he was smiling with pale lips. His eyes were shiny and reckless. His hands shook a little. (Hammett, 1975, p. 127)

That physical activity suggests emotion in these sentences is indicated by the reference to the character's smile and by his "reckless" eyes. Yet what he really thinks remains unstated. It may be a challenge to the reader to reconstruct his undisclosed thoughts along the lines of the theory of mind. (Zunshine, 2006) Our capacity for mind reading can be in demand if we are confronted with real people just as with literary figures. We may encounter analogous situations in real life and in the fictional world of the screen or the book. When a person's gestural and facial activity goes without words we have to perform a cognitive achievement. An example from one of Raymond Chandler's novels, which are told by the I-narrator Philip Marlowe, represents the body action of a person, who has committed body-stripping, from the narrator's perspective. The following quotations have been collected from the scene in question, in which pressure is put on the character by the narrator:

- (2) Tiny beads of sweat showed on Flack's lip above his little moustache. – He hunched down in a chair and stared at the corner of the desk. After a long time, he sighed. – His eyes were small and thoughtful. His tongue pushed out over his lower lip. – I stopped and watched the faint glisten of moisture forming on his forehead. He swallowed hard. His eyes were sick. – He just sat there and stared at me with his nasty little eyes half closed and his nasty little moustache shining. One of his hands twitched on the desk, an aimless movement. (Chandler, *The Little Sister*, 1975, Chapter 11)

The emotions of the character remain unspecified. The representation is restricted to outward physical manifestation. Yet the effect on the reader is to perceive, in a cognitive act, the character as extremely uncomfortable. Nor is the narrator's response explicitly communicated. His attitude of distaste and contempt is only suggested by the dinginess and meanness of the described person and by the adjective "nasty" which is applied to

the eyes and moustache. The representation of his own facial activity as a response is not possible for the narrator, for the text is written in the form of I-narration. Yet it is astonishing to what extent the narrator applies description of physical details also to his own body, as the two following examples show:

- (3) I grinned suddenly, bent over and quickly and with the grin still on my face, out of place as it was, pulled off Dr. Hambleton's toupee [...] (Chandler, 1975, *The Little Sister*, Chapter 9)
- (4) Then I put it [the telephone] down very slowly and looked at the hand that held it. It was half open and clenched stiff, as it was holding the instrument. (Chandler, 1975, *The Lady in the Lake*, Chapter 28)

In the first quotation the narrator describes even a facial manifestation – grinning, the grin on his face –, which he cannot see. For the explication of more complicated examples we have to refer to the concepts of mirror neurons and theory of mind. To do so in a graphic way we will first look at a painting which refers to a complex situation of interfacial response, Nicolas Poussin, “Landscape with a Man Killed by a Snake” (1648). The reason for the shift of our argument to another art medium is that an interfacial phenomenon is, in this ocular form, easier to grasp and interpret.



Nicolas Poussin, Landscape with a Man Killed by a Snake 1648, The National Gallery, London

This painting, which has been characterized as a “study in fear” and has been used as a cover image for Richard Wollheim’s book *On the Emotions* (1999), reproduces an

emotionally disturbing scene in an apparently serene Arcadian landscape. At the bottom of the left-hand side a man is being killed by a snake. From the right side a young man with terrified, pain-distorted face, turned to the spectator, is fleeing from the place of the accident. The emotional stress represented in the face is unfortunately not to be seen clearly enough in the reproduction of the painting, which is exhibited in the National Gallery in London. In the middle of the painting there is a woman, who from her position cannot perceive the place of the accident. But her face and posture assumes the same pained appearance as the man's. Her agitation is also shown in her wild gestures and her forward-bending posture. She may be screaming. If she were a real person, we would have to say that her motor cortex has been activated most strongly by the running man she is seeing.

Poussin leaves the accident itself almost in the dark. The painting's emphasis is on the emotions reflected in the faces of the two other figures. The fact that the woman, though not knowing the reason for the man's fear, shows the same physical evidence of fear as the man, can be, from a contemporary scientific vantage-point, explained by the theory of mirror neurons. This theory, which I referred to earlier in this paper, is based on the empirically gained insight – first derived from the observation of monkeys – that the same parts of the brain are active when a person performs an action as when the person sees another individual performing the same action. (Rizzolatti: 1999, 2526–2528) This phenomenon can be explained in terms of the facial feedback theory. It would also be possible to explain Poussin's scene of facial interaction in terms of the theory-of-mind concept.<sup>2</sup> This would mean that the woman in the painting, looking at the frightened face of the man, forms an idea of what he feels and feels the same by way of empathy, as her facial aspect indicates. In fact, in a recent article on face-to-face interactions Martin Schulte-Rüther et al. (2007) applied both the Mirror Neuron Theory and the Theory of Mind to face-to-face interaction. I personally would prefer to describe the scene in the painting under discussion as face-to-face interaction with embodied cognition on the part of the woman. She empathizes with the man on account of the pain manifested in his face, the empathy causing motor activity. That mind reading and cognition belong together is stated by Alan Richardson's following quotation: "What's termed our 'theory of mind' [...] would be greatly impoverished if we did not have a reasonably reliable, and therefor largely unconscious, cognitive mechanism for gauging the emotions and intentions of others through reading their faces." (Richardson 2010: 65)

---

<sup>2</sup> This was suggested to me by my colleague Dirk Vanderbeke.

Let us now look at two passages in Raymond Chandler's novel *The Little Sister*, where the protagonist realizes his emotional state only by looking at himself in a mirror:

- (5) Passing the open door of the wash cabinet I saw a stiff excited face in the glass. I went over to the wash-basin and washed my hands and face. I sloshed cold water on my face and dried it off hard with the towel and looked at it in the mirror. 'You drove off a cliff all right,' I said.  
(Chandler, 1975, *The Little Sister*, Chapter 23)
- (6) I got up and went to the built-in wardrobe and looked at my face in the flawed mirror. It had a strained look. I'd been living too fast. (Chandler, 1975, *The Little Sister*, p. 133)

These examples may be a far cry away from Lacan's theory of the mirror phase in which the child for the first time succeeds in recognizing and identifying him/herself as a complete self in front of a mirror, but the look of the protagonist at himself in a mirror in the novel by Chandler also has a cognitive function. In the passages quoted the narrator finds out something about himself by looking at himself. In the first example the narrator even talks to his face. It would be problematic to apply the mirror neuron concept to self-perception in the two passages, for one would have to assume self-division in the observer, in which one part of the self observes the other part, although a dual self is indicated in the first quotation, which refers to "a stiff excited face" and not to "my stiff excited face". The protagonist even addresses his face. The two examples could be explained as special instances of the theory of mind applied to a character finding out something about his person by looking at himself in a mirror. However, more plausible would be the reference to Daryl Bem's "self-perception theory". This theory explains that people form new attitudes and beliefs, including those related to the self, from observing their own behavior. Bem (1967) maintains that people deduce their own internal states, like attitudes and emotions via the same processes by which they deduce the internal states and dispositions of others. Specifically, Bem assumes that people use their facial expressions as a source of information to infer their own attitudes. This is what happens in the two quotes in which Philip Marlowe looks at his own face in the mirror. Before the mirror the character comes to self-perception and partially also to conclusions concerning the state of his mind. Be that as it may, in the context of sensory motor concepts the novels by Hammett and Chandler provide abundant evidence of embodied cognition.

#### 4 Emotion as Cognition I: An Example from Narrative Prose

As for emotion, I am making a wide claim, namely to postulate that emotional experiences, whether actual or imaginary, are cognitive events, to which sensory motor processes contribute essentially. A similar position has been taken by Meyer-Sickendieck (2012) who regards the perception of moods as cognitive acts which have a profound effect on the body. Physical manifestations like the body shaking, the heart beating faster, eyes being averted and facial expressions like smiling or tears are more than "physiological accompaniments", as Oatley states (Oatley, 1994, p. 53, Oatley, 1992. p. 20–21), but, looked at in the context of the present project, they are part and parcel of cognition. In this respect the approach taken here differs from Raymond Gibbs' important chapter on emotion (Gibbs, 2005, pp. 239–274), which focuses on consciousness rather than cognition. I can, however, not refer to empirical evidence for substantiating my assumptions concerning the representation of emotion in literature. Meyer-Sickendieck pursues such an empirical project, as he declares in the conclusion of his book, but his methodology does not seem to reach the precision of brain scientists. As a literary critic I have to rely on literary texts. Since poetic language does not differ radically from everyday language and since poetic language frequently evinces linguistic features which are a heightened form of normal speech, my examples may perhaps be not without relevance for linguists and cognitive scientists.

I will begin with an example of narrative prose, a passage from William Faulkner's novel *Light in August*, which deals with the fate of a white African-American:

- (7) He turned into [the street] running and plunged up the sharp ascent, his heart hammering, and into the higher street. He stopped here, panting, glaring, his heart thudding as if it could not or would not yet believe that the air was now the cold hard air of white people. (Faulkner, 1971, p. 88)

Here physical action emerges as emotion, be it fear or revulsion. While running from a district of blacks to a district of whites, the protagonist passes through different emotional states. As frantic as he may be, he is aware of what happens. The passage represents motion and emotion and cognition in an insoluble conjunction. Emotion *is* motion, as the pounding heart indicates. The passage can be regarded as an extreme literary example of embodied cognition, in which the sensory-motor component goes together with cognition.

## 5 Emotion as Cognition II: Examples from Romantic Poetry

Romantic lyric poetry represents, on the whole, a strongly subjective and intimate form of discourse which with its orientation on the individual self tends to be at variance with the socially established systems of discourse which, according to Niklas Luhmann (*Liebe als Passion*, 1982), influence linguistic and literary representation. It may be objected that it makes no sense to approach this kind of poetry, which is to a large extent characterized by interiority, from the point of view of the sensory-motor concept. I will try and show that such an objection would not be justified. My analysis begins with a look at a notoriously emotional poem, which has a curious aspect that had puzzled me for a long time until I looked at it in terms of the sensory-motor concept. It is Percy B. Shelley's "The Indian Serenade". In this poem it is intense emotion which makes the lover "arise from dreams" of his beloved and forces him to her chamber-window. Emotion inevitably concurs with motion. The speaker declares that it is a "spirit in my feet" which leads him to her window:

- (8) And a spirit in my feet  
Hath led me – who knows how?  
To thy chamber window, Sweet! (Shelley, 1970, p. 500)

The puzzling phrase in this poem is "a spirit in my feet". For a neuroscientist it may seem absurd or downright silly to locate a "spirit" in a foot. But it is interesting that Shelley, who could not know anything about neuroscience, felt the need for a physical source or agency which caused the action of his lover, a source interestingly different from the heart which would in the cardiocentric tradition (Niemeier 2011) be responsible for a lover's action. The heart or the soul is, at least in this poem, not the seat of the feelings. Nowadays we would of course retrace the source of the lover's motion in the poem to his brain. In want of any such concept the foot had to serve as a kind of substitute. The passage explicitly illustrates a coincidence of emotion and motion with cognitive implications. Cognition is involved in the self-observation and the self-description of the poems' speaker.

The following quotations from romantic poems provide evidence for the hypothesis that emotion tends to be represented as cognition and to be embodied in motion in the poetry of the age. Lines like –

- (9) I die! I faint! I fail ("Indian Serenade", Shelley, 1970, p. 580)  
(10) I pant, I sink, I tremble, I expire! (*Epipsychidion*, Shelley, 1970, p. 424)



- (11) My heart aches, and a drowsy numbness pains  
My sense, as though of hemlock I had drunk,  
Or emptied some dull opiate to the drains  
One minute past and Lethe-wards had sunk:  
[. . .] (“Ode to a Nightingale”, 1–4, Keats, 1970, p. 207)

– have traditionally been called subjective or self-expressive. The most important representative of a poetics of expression which accounts for such texts, emphasizing notions of subjectivity and expressiveness, is M. H. Abrams’ famous book *The Mirror and the Lamp* (1953). In the light of sensory-motor concepts such poems should rather be called self-diagnostic or self-reflexive. It is significant that in all these examples emotion coincides with motion. Emotion manifests itself in physical terms or, more precisely, in motion. This is the case even in the lines from Keats’ ode, although the depressed state of having “sunk” down is described only on a metaphorical level. Poetry intensifies here what we have noted above with reference to everyday language, namely that emotional states are frequently expressed in physical terms, for example in words like “downcast” (German “niedergeschlagen”) or “spurred” (German “beflügelt”). Keats is, incidentally, one of the greatest diagnosticians in English poetry, which reflects his deep interest in medicine and new ideas in brain anatomy and neurophysiology. (Richardson 2010: 75) Here is another example. In “Ode on a Grecian Urn” the “happy” world depicted on the urn is described, which is far above “all breathing human passion”

- (12) That leaves a heart high-sorrowful and cloy’d,  
A burning forehead, and a parching tongue. (Keats, 1970, p. 210)

The lines refer to an emotion of extreme sorrow, but the terms in which it is represented are intensely physical or sensory, almost in the form of a medical diagnosis. Self-description is intensified to the point of self-diagnosis: the heart is sickened, the forehead burning, and the tongue dried out. The great amount of physical manifestation in these and many more cases is a testimony of cognition rather merely accompaniment of it.

In order to point at the recipient’s side of an embodied understanding of emotion I will quote a passage from the poet A. E. Housman’s famous lecture *The Name and Nature of Poetry* in which he equates the emotional effect of poetry with a physical one:

- (13) Experience has taught me, when I am shaving of a morning, to keep watch over my thoughts, because, if a line of poetry strays into my memory, my skins bristles so that the razor ceases to act. This particular symptom is accompanied by a shiver

down the spine; there is another which consists in a constriction of the throat and a precipitation of water to the eyes: and there is a third which I can only describe by borrowing a phrase from one of Keats's last letters, where he says, speaking of Fanny Brawne, 'everything that reminds me of her goes through my like a spear'. The seat of this sensation is the pit of the stomach. (Housman, 1933, p. 47)

This is an extreme example of the effect of poetry caused by emotions which react on the body in a multitude of ways from a bristling of the skin to the sense of being penetrated by a spear in the pit of the stomach. The importance of the physical side in the representation of emotions, which is emphasized in my argument, could be supplemented by investigations of the production and the reception side of the poetic process, which is not possible within the frame of this article.

## 6 Embodied Cognition in a Modern Poem

The lyrical poems dealt with so far have been taken from romantic poetry. To give just a glimpse of embodied cognition, which continues to emerge, in varied forms, in later poetry, at least one twentieth-century poem will be adduced. In this context the study by Burkhard Meyer-Sickendiek has to be referred again, *Lyrisches Gespür. Vom geheimen Sensorium moderner Poesie*. (2012). Meyer-Sickendiek is strongly interested in the lyric representation of fugitive moods which are barely felt out by a sensitive subject and he discusses the corporeality of perception. His theoretical approach, which is focused on mood ("Stimmung") rather than feeling, is related to the New Phenomenology of Hermann Schmitz. It provides the basis for extremely subtle analyses. Although it does not refer to sensory-motor concepts, it ties in with the present study, since it understands the apprehension of a mood ("das Erspüren einer Stimmung") as a cognitive act. The poem to be looked at here is by William Carlos Williams:

(14) To a Poor Old Woman

munching a plum on  
the street a paper bag  
of them in her hand  
They taste good to her  
They taste good  
to her. They taste  
good to her

You can see it by  
the way she gives herself  
to the one half  
sucked out in her hand  
Comforted by  
a solace of ripe plums  
seeming to fill the air  
They taste good to her  
(Williams, 1951, p. 99)

In this poem there is a total focus on the woman who is eating plums with the greatest relish, even sucking the fruit from her hand. Her feelings of sensuous pleasure are denoted by the statement “They taste good to her”. Even the last stanza, which articulates a kind of epiphany, is concentrated on smell and taste. In the second stanza it is the device of repetition with the shifting of the line ends within the repeated sentence, – an intricate counterpointing of syntax and meter – which has an iconic and intensifying effect. The shifting enjambment mimes the process of munching and savouring the plums. The notion of embodied feeling is here expressed by a distinct poetic technique – repetition. The last stanza conveys a sense of satisfaction which transcends the limits of the object beheld. Emotion words refer to sensuous contentedness (“Comforted / a solace of ripe plums”) and an impression of the air being filled with the smell of plums (“seeming to fill the air”) is evoked. There is also a cognitive component in the woman’s pleasure. She obviously knows what she is doing and she enjoys what she is doing, as it is suggested by the repeated clause, “They taste good to her”. The poem is an interesting case in that in addition to the visual dimension it includes the senses of tasting and smelling. Its imagery is multisensory. (Starr, 2010) It is one of the purest examples of embodied feeling in poetry.

## **7 Emotion Manifested in Kinetic Body Metaphors**

From a cognitive point of view there is hardly a difference between metaphor in general and in literary language. Lakoff and Johnson argue that human thought and speech are constructed metaphorically from the basic kinesthetic experiences of living in a body (Crane 2010: 104). In an illuminating experiment Boulanger, Hauk and Pulvermüller (2009) could show that idioms – which contain action metaphors like “grasping the idea” – activate the motor cortex just as non-figurative expressions referring to action

do. Their conclusion is that “Motor systems of the brain, including motor and premotor cortex, and the motor cognitions they process appear to be central for understanding idioms.” (Boulanger, Hauk and Pulvermüller 2008: 1913) Metaphors which refer to motions of the body like

- (15) My blood freezes – I could vomit – He fell into a tumult of contradictory feelings –  
Grasping ideas requires some intelligence

are not radically different from metaphors in poetry. The most important difference seems to be that poetic metaphors usually strive for the quality of novelty or originality. It can be said that metaphor is a supreme device of expressing emotion in poetry. It is in fact a catalyst of emotion. Also in this context the relation between motion and emotion, which is our topic, is particularly frequent, as the poems quoted above show. Further evidence is provided by the following examples from Gerard Manley Hopkins’ so-called *terrible sonnets* (Poems 65 and 67):

- (16) No worst, there is none. Pitched past pitch of grief,  
More pangs will, schooled at forepangs, wilder wring. (Hopkins, 1967, p. 100)

- (17) Selfyeast of spirit a dull dough sours. (Hopkins, 1967, p. 101)

- (18) I am gall, I am heartburn. God’s most deep decree  
Bitter would have me taste: my taste was me;  
Bones built in me, flesh filled, blood brimmed the curse. (Hopkins, 1967, p. 101)

In each of these instances extreme emotions are rendered in physical terms: in the first case spiritual pain manifests itself physically in terms of wringing pangs, in the second the self’s spiritual helplessness is expressed by the image of the leaven of the self, unable to raise a dough, and in the third metaphors of taste are used to express the emotional state of the self, which is, in the absence of God, thrown back on itself and has to taste itself. It should not be forgotten that these are written or rather printed words, condensed dust on the page, if you do not read them aloud, and yet there is an enormous sense of physicality to them;<sup>3</sup> the body as the testimony of emotions is powerfully present, for, as we have argued, the respective areas of the brain are activated regardless of their metaphorical character. At the same time Hopkins’ lines evince great self-awareness and self-perception on the part of the speaker. Again I

---

<sup>3</sup> I am aware that reading a poem silently also has a sensory quality. If this was not the case, sound effects and the rhythmical quality of the poem would remain unnoticed. The exploration of this phenomenon would be another challenge of cognitive research.

would not like to call such poetic discourse self-expression. On account of its strong cognitive quality I would prefer the term self-definition or self-diagnosis.

## 8 A Note on Embodied Cognition in Literature and the Historical Aspect – Shakespeare

The examples adduced for embodied cognition in the context of the representation of emotion have been taken from nineteenth and twentieth-century literature. The textual corpus should, of course, be extended to earlier literature, and it should be asked whether historical developments can be identified in the treatment of the relation of emotion and motion in literature. A first impression gained during the research for this study is that a climax of embodied cognition and emotion is to be found in the literature of the romantic period. However, it is evident that further historical research and an expansion of the corpus are needed. Petrarch's *Canzoniere*, for instance, one of the most important models for lyric production all over Europe, has explicit descriptions of feelings in physical terms such as the lover's freezing and burning in his changing moods. It would certainly be fruitful to look at Petrarch and his tradition or at metaphysical poetry with respect to embodied feeling and cognition, but I would like to have just a brief look at Shakespeare, who in this, as in so many other aspects, proves to be quite modern. Darwin quotes him as one of the chief authorities on human expression. (Alan Richardson 2010: 71) There is no room to go into Mary Thomas Crane's important study on conceptual metaphors in *Shakespeare's Brain*. (2000) First, two lines from Hamlet's first soliloquy are to be quoted:

- (19) O that this too sullied flesh would melt,  
Thaw, and resolve itself into a dew,  
(Shakespeare 2005, p. 113, Act I, Scene 2, ll. 129–30)

Hamlet's disillusionment with his family and his self-loathing are manifested in physical terms, in his desire for his body to melt away. The protagonist does not in the first place refer to his feelings of depression, but his psycho-physical condition. Hamlet's world-weariness manifests itself in a desire for the dissolution of his body. Another example is Macbeth, who contemplates murder to gain the crown, yet is so terrified by fear that the image of murder unsettles his bodily functions,

- (20) [...] why do I yield to that suggestion  
Whose horrid image doth unfix my hair,

And make my seated heart knock at my ribs,  
Against the use of nature? (Shakespeare, 1971, p. 21, Act I, Scene 3, ll. 134–37)

Here again the image of the body's life, with the hair standing on end and the heart knocking at the ribs, coincides with the protagonist's feelings. In fact, the physiological event is not a mere symptom, but a manifestation of mental disorder. There is also a pronounced cognitive dimension in the passage, in the form of self-observation and self-diagnosis. Macbeth feels an emotion and simultaneously perceives it as a manifestation of the body.

An examination of modernist poetry could lead to the result that there are poets like T.S. Eliot and Wallace Stevens who tend to write 'disembodied' poetry, i.e. poetry that is averse to embodied cognition, while others like Ezra Pound and William Carlos Williams are in favour of embodied cognition. As early as 1988 Max Nänny wrote an article on Ezra Pound as a "Right Brain Poet". By way of analogy one could call T.S. Eliot a left brain poet. But such classifications should be treated with caution from a cognitive and historical point of view. As far as Eliot is concerned, his theory of the "dissociation of sensibility" could be discussed in terms of the cognitive approach.

## 9 Conclusion

It may be objected that the material treated in this study is rather diversified and disparate and that the evidence presented moves freely between genres and periods, but as an extenuating circumstance it can be pointed out that an innovative approach is tried out in this contribution, which opens new perspectives and is waiting to be substantiated in a more comprehensive and systematic procedure. Some results can at least be ascertained. Emotion and motion have turned out to be two sides of a coin. Motion is understood as the kinesthetic experience of the body, which comes into play with any emotional experience, no matter whether in real life or fiction, although the literary artist has aesthetic strategies at his or her disposal which make possible intensified representation of emotion. Analyses have shown that literature is a veritable field for experimentation in matters of embodied cognition. Embodied cognition could be identified in the representation of facial feedback, both in views from outside (external) and from inside (internal). The thesis that emotion is closely linked to physical manifestation, that emotion is actually inseparable from motion has been confirmed in numerous examples from narrative prose and poetry. The application of the term "sensory-motor" to cognitive phenomena represented in literature proved to have certain advantages,

since it allows for the appreciation of different aspects of body activity involved in cognition (changes of the position of the body, movement of the limbs, facial expression, smelling, taste), which could be found in the instances of represented emotion examined. It should be noteworthy and encouraging for cognitivists and neuroscientists advocating sensory-motor concepts that in literature there is massive evidence for their theories from times in which nobody as yet dreamed of neurons let alone sensory-motor concepts. The interdisciplinary benefit can be mutual, the literary scholar profiting from the mind and brain scientist exploring hitherto unknown dimensions of human reality, and the scientist learning that poets have all along known more about the mind's construction than they would have believed possible.

## 10 References

- Adelman, P. K. and R. B. Zajonc (1989). Facial Efference and the Experience of Emotion. *Annual Review of Psychology*, 40, 249–280.
- Barsalou, L. W. (2008). Grounded cognition. *Annual Review of Psychology*, 59, 617–645.
- Barsalou, L. W. (2010). Grounded cognition: Past, present, and future. *Topics in Cognitive Science*, 2, 716–724.
- Boulanger, V., Hauk, O. & F. Pulvermüller (2009). Grasping Ideas with the Motor System: Semantic Somatotopy in Idiom Comprehension. *Cerebral Cortex* 19, 1905–1914.
- Chandler, R. (1975). *The Lady in the Lake*. Harmondsworth: Penguin.
- Chandler, R. (1975). *The Little Sister*. Harmondsworth: Penguin.
- Crane, M. T. (2000). *Shakespeare's Brain: Reading with Cognitive Theory*. Princeton: Princeton University Press.
- Crane, M. T. (2010). Analogy, Metaphor, and the New Science: Cognitive Science and Early Modern Epistemology. In: Zunshine (Ed.), 103–114.
- Damasio, A. (1994). *Descartes' Error*. London: Penguin.
- Damasio, A. (1999). *The Feeling of What Happens. Body and Emotion in the Making of Consciousness*. New York, San Diego, London: Harcourt Brace.
- Faulkner, W. (1971). *Light in August*. Harmondsworth: Penguin.
- Gallese, V. & G. Lakoff (2005). The Brain's Concepts: The Role of the Sensory-Motor System in Reason and Language. *Cognitive Neuropsychology*, 22, 455–479.
- Gibbs, R. W. J. (2005). *Embodiment and Cognitive Science*. Cambridge: Cambridge University Press.

- Glenberg, A. M. & M. P. Paschak (2002). Grounding language in action. *Psychonomic Bulletin & Review*, 9, 558–565.
- Hammett, D. (1975). *The Glass Key*. London and Sidney: Pan Books.
- Hogan, P. C. (2010). On Being Moved: Cognition and Emotion in Literature and Film. In Zunshine (Ed.), 237–256.
- Hopkins, G. M. (1967). *The Poems of Gerard Manley Hopkins*. London, New York, Toronto: Oxford University Press.
- Housman, A. E. (1933). *The Name and Nature of Poetry*. Cambridge: At the University Press.
- Keats, J. (1970). *Poetical Works*. London, Oxford, New York: Oxford University Press.
- Lakoff, G. & M. Johnson (1999). *Philosophy in the Flesh*. New York: Basic Books.
- Meyer-Sickendiek, B. (2012). *Lyrisches Gespür. Vom geheimen Sensorium moderner Poesie*. München: Fink.
- Müller, Wolfgang G. (1981). Implizite Bewußtseinsdarstellung im behavioristischen Roman der zwanziger und dreißiger Jahre: Hammett, Chandler, Hemingway, *Amerikastudien*, 26, 193–211.
- Nänny, Max (1988). Ezra Pound: Right Brain Poet. *Paideuma*, 17.2/3 (Fall/Winter), 93–109.
- Niemeier, S. (2011). Culture-specific concepts of emotionality and rationality. In M. Callies, W. R.
- Keller & A. Lohöfer (Eds.), *Bi-Directionality in the Cognitive Sciences*. Amsterdam, Philadelphia: Benjamins, 43–56.
- Oately, K. (1992). *Best Laid Schemes: The Psychology of Emotions*. Cambridge etc.: Cambridge University Press.
- Oately, K. (1994). A taxonomy of the emotions of literary response and a theory of identification in fictional narrative. *Poetics*, 23, 53–74.
- Pezzulo, G., L. W. Barsalou, Cangelosi L. W., A., Fischer, M.A., McRae, K. & M. Spivey (2011). The mechanics of embodiment: A dialogue on embodiment and computational modeling. *Frontiers in cognition*, 2(5), 1–21.
- Ratcliffe, M. (2008). *Feelings of Being. Phenomenology, Psychiatry and the Sense of Reality*. Oxford: Oxford University Press.
- Richardson, A. (2010). Facial Expression Theory from Romanticism to the Present. In Zunshine (Ed.), 65–83.
- Schrott, R. & A. Jacobs (2011). *Gehirn und Gedicht. Wie wir unsere Wirklichkeiten konstruieren*. Hamburg: Hanser Verlag.



- Shakespeare, W. (2005). *Hamlet*. Englisch-deutsche Studienausgabe. Ed. N. Greiner, W. G. Müller. Tübingen: Stauffenburg Verlag.
- Shakespeare, W. (1971). *Macbeth*. Ed. K. Muir. Arden Edition. London: Methuen.
- Shelley, P. B. (1970). *Poetical Works*. London, Oxford, New York: Oxford University Press.
- Starr, G. (2010). Multisensory Imagery. In Zunshine (Ed.), 275–291.
- Stockwell, P. (2002). *Cognitive Poetics*. London, New York: Routledge.
- Williams, W. C. (1951). *The Collected Later Poems*. New York: New Directions.
- Wilson, M. (2002). Six views of embodied cognition. *Psychonomic Bulletin & Review*, 9, 625–636.
- Wolman, B. B., Ed. (1973). *Handbook of General Psychology*. Englewood Cliffs: Prentice-Hall.
- Zunshine, L. (2006). *Why We Read Fiction: Theory of Mind and the Novel*. Columbus: Ohio State University Press.
- Zunshine, L., Ed. (2010). *Introduction to Cognitive Cultural Studies*. Baltimore: The Johns Hopkins Press.



**THE DIVERSITY OF SENSORY-MOTOR  
CONCEPTS AND ITS IMPLICATIONS**



GERARD STEEN

## Sensory-Motor Concepts and Metaphor in Usage

Gerard Steen  
University of Amsterdam,  
Faculty of Humanities

[g.j.steen@uva.nl](mailto:g.j.steen@uva.nl)

### Abstract

This paper explores the relation between metaphor and Sensory Motor concepts in language use. Sensory Motor concepts in language use are defined as a number of semantic fields distinguished by WMatrix, comprising Sensory lexis and Motor lexis, including words under 'Sight' and 'Sound' as well as 'Moving, Coming, Going' and 'Pushing, Putting, Pulling'. The incidence of this lexis and its metaphorical use is examined in the VU Amsterdam Metaphor Corpus, a 190,000 word selection from BNC Baby annotated for metaphor. The relation between the selected semantic fields and metaphorical and non-metaphorical use reveals a substantial distinction between the metaphorical use of Sensory Motor lexis and all other lexis as well as between the metaphorical use of Sensory lexis and Motor lexis. Interactions with word class and with genre are also explored, indicating more specific behavior of each of the various groups of lexis expressing the distinct concept categories. The paper concludes by suggesting that Sensory-Motor concepts may indeed play a special role in metaphorical language use, and that additional distinctions are needed to capture the four-way interaction between metaphor, word class, register and semantic field.

Keywords: Sensory-Motor concepts, semantic fields, metaphor, language use

## 1 Introduction

How are Sensory-Motor concepts expressed in language? And when are Sensory-Motor concepts used metaphorically in language? I will explore these questions in order to offer some tentative views of the relation between Sensory-Motor concepts and metaphor in usage. The connection between Sensory-Motor concepts and metaphor is natural since Sensory-Motor concepts afford one of the most popular source domains for generating metaphorical language and thought: according to the influential cognitive-linguistic account of metaphor launched by Lakoff and Johnson (1980), we think of for instance understanding as a sensory experience (*UNDERSTANDING IS SEEING*) and of change as a motor experience (*CHANGE IS MOTION*). More recently, one basic group of metaphors, called 'primary metaphors', have been distinguished on the basis of their immediate grounding in embodied cognition by means of so-called 'image schemas', which are presumably derived from sensory-motor experience (e. g., Gibbs,

2006; Hampe, 2005). Since then, Sensory-Motor concepts have been taken as fundamental to figuration in thought and language (e. g., Lakoff and Johnson, 1999; Mandler, 2004).

In this paper I will utilize a substantial set of generally representative linguistic data to explore the relation between Sensory-Motor concepts and metaphor in usage. Previous work done in our lab led to the first attempt at an encompassing corpus-linguistic description of the relation between metaphor and its use in language (Dorst, 2011; Herrmann, 2013; Kaal, 2012; Krennmayr, 2011; Pasma, 2011; Steen et al., 2010a, b). This research on metaphor in usage has shown a highly varied distribution of metaphor across registers and word classes:

- Some registers are more metaphorical than others, ranging from academic and news through fiction to conversation.
- Some word classes are also more metaphorical than others, ranging from prepositions and determiners through nouns and verbs to adjectives and adverbs.
- And some word classes are more metaphorical in some registers than in others; for instance, adjectives have higher metaphorical usage in news, fiction and conversation than may be expected by chance, but not in academic texts, where they do behave according to chance (Steen et al, 2010a: 211).

Since, in addition, some word classes are more frequent in some registers than others (cf. Biber and Conrad, 2009), the underlying general interaction between register and word class needs to be taken into account when interpreting the relation between metaphor, register and word class.

These patterns were determined without paying explicit attention to their relation to distinct semantic fields. The data do naturally include the use of all semantic fields that can be distinguished, including those fields presumably relating to Sensory-Motor concepts. This means that, in theory, the relation between Sensory-Motor concepts and metaphor in usage could be analyzed as a four-way interaction, between (a) Sensory-Motor concepts, (b) metaphor, (c) register and (d) word-class. Taking our previous work as a provisional startingpoint, the simplest model of this four-way interaction would yield a  $2^2 \cdot 4 \cdot 8$  design for analysis, with Sensory-Motor concepts having two levels (Sensory-Motor concept or not), metaphor having two levels (metaphor or not), register having four levels (academic, news, fiction, and conversation), and word class having eight levels (adjective, adverb, conjunction, determiner, noun, preposition, verb, remainder). Such a design is clearly much too complex to remain meaningful without further context, certainly for an exploratory paper like the present one. I am therefore

going to dismantle the four-way interaction into a number of components that are theoretically meaningful in order to achieve a first understanding of the possible relation between Sensory-Motor concepts and metaphor in usage. The following findings are hence partial and tentative, in the awareness that future research on a grander scale will have to take into account more complex interactions as possibly influencing the general trends.

The overall aim of this exploration is to sketch a first picture of the employment of Sensory-Motor concepts for metaphorical purposes in language use. Data collection and analysis are based on a data set that has since been corrected, requiring another round of research in order to take these corrections into account. I have also selectively applied just a handful of small-scale statistical tests that ideally need inclusion in a more encompassing and sophisticated approach in the future. What I aim to do in this paper, therefore, is to present a relatively informal account of the most important tendencies in the data that are visible in spite of the error and noise I just acknowledged. Since these most important tendencies are starkly visible, future research is not expected to have drastic effects on the present conclusions and is hoped to profit from the first sketch and new questions I can offer at this moment.

## **2 Method**

The data were collected from the VU Amsterdam Metaphor Corpus (Krennmayr and Steen, in press), a sample of just under 190,000 words from the BNC Baby, which itself is a four-million word sample from the British National Corpus. This is a 100 million word collection of samples of written and spoken language from a wide range of sources, representative of present-day British English. The VU Amsterdam Metaphor Corpus (from now on, 'VUAMC') was annotated for metaphor, yielding about 25,000 metaphor related words (13.6%). These were then analyzed for relations with word class and register, revealing a three-way interaction between metaphor, word class, and register (Steen et al., 2010a, b). The version of the database used for the present paper still includes a number of mistakes, both in Part-of-Speech tagging as well as in metaphor annotation. These were since corrected for a second, revised edition but the figures presented here are adequate enough to be representative for a first exploration of the trends discovered.

All separate VUAMC text files were concatenated into four long files organized by register: academic texts, news texts, fiction, and conversation. Each of these files was

uploaded into WMatrix, a web interface including a tool for semantic field identification (Rayson, 2009). The semantic fields distinguished in WMatrix are applied in its lexicon which describes the various senses of the distinct words in the English language that have been included. Words in a text that is uploaded can thus be automatically analyzed for the semantic domains that WMatrix attaches to the lexical units. WMatrix makes a distinction between 21 broadly defined semantic fields, including M, 'movement, location, travel and transport', and X, 'psychological actions, states, and processes', with additional subcategories. Six Sensory-Motor domains were deemed of highest interest to the exploratory purposes of this study: M1, 'Moving, Coming, and Going', M2, 'Pushing, Putting, and Pulling', and M6, 'Location and Direction', as well as X3, 'General Sensory', X3.2, 'Sound', and X3.4, 'Sight'. Lexical items representing these domains include *leave, turn, walk* (M1), *take, place, hold* (M2), *to, in, there, where* (M6), *feel, feeling, experience, sense* (X3), *hear, sound, noise* (X3.2), and *see, look, eye* (X3.4). It should be noted that all of these classifications are based on independent work done for WMatrix by Paul Rayson and his associates (Rayson, 2009). I hence take on board any decisions they have made in assigning particular lexemes to particular semantic fields and conceptual categories. For instance, it is self-evident that these decisions have to do with the value of lexical units in the present-day system of the English language and ignore their historical provenance, even though this may be relevant for other research purposes. It is only by exploiting the tool as it is available now in empirical work in specific areas like the one reported here that constructive criticism can be formulated and the tool can be improved for future work.

An example of the output of WMatrix for one sentence is given below:

```
0000025 010 AT      The           Z5
0000026 010 MC2     1990s        T1.3 N1 T3
0000027 010 VH0     have         Z5 A9+ A2.2 S4
0000028 010 VVN     witnessed    X3.4 G2.1 A10+@ S9
0000029 010 AT1      a            Z5
0000030 010 NN1@     shift       A2.1+ S5+c T1.3/I3.1
0000031 010 II       in           Z5
0000032 010 AT      the          Z5
0000033 010 NN1      art          C1 X9.1+
0000034 010 NN1     establishment T2+ H1c G1.1c I3.1c
0000035 010 GE       's          Z5
0000036 010 NN2     attitudes    X2.1/E1
0000037 010 II       towards     Z5
0000038 010 NN1      art          C1 X9.1+
0000039 010 VVN     produced    A2.2 A1.1.1 A10+ K4 K3 Q4.3 F4
0000040 010 II2I     outside     M6[i2.2.1 A1.8-[i2.2.1 Z5
```



## Sensory-Motor Concepts and Metaphor in Usage

```
0000040 020 II22 of M6[i2.2.2 A1.8-[i2.2.2
0000041 010 APPGE its Z8
0000042 010 JJ traditional S1.1.1 A6.2+ T3++
0000043 010 NN2 parameters A1.7+ N3.1 N2
0000044 001 . .
```

Case numbers are followed by clause identifiers and Part-Of-Speech tags for the relevant lexical unit located in the fourth column. Each lexical unit is then followed by the list of semantic field tags assigned to it by WMatrix. If a word is tagged as M1, M2, or M3 or X3, X3.2 or X3.4, as is the case for units 028, *witnessed*, and 040, *outside/of*, it is included in our study as expressing a Sensory-Motor concept.

A special feature called ‘domain push’ was activated for the selected domains. The domain push function enables identification of all lexical units that have these semantic domains, even when these semantic domains are not the relevant sense in context. The latter is clearly important for the identification of those words that are used in abstract senses in the current context but in concrete Sensory-Motor senses in other contexts.

All WMatrix output was visually inspected and a small set of overt errors were adjusted or removed. The data were then included in an SPSS database containing the general VUAMC information, including register and text identification, word class information, and metaphor information. This database was subjected to a small number of non-parametric statistical analyses by means of the chi-square test in order to examine first associations between a number of selected variables for portions of the data. A more sophisticated and encompassing quantitative analysis is envisaged for future research.

### 3 Results

#### 3.1 Sensory Concepts, Motor Concepts, and Metaphor

Sensory concepts and Motor concepts in this study each comprise three subcategories, which may or may not display their own specific behavior in relation to metaphor. That is what we will examine in this section. We now first turn to the group of Sensory concepts, divided into three categories: General Sensory concepts, Sound concepts and Sight concepts. Their relation to metaphorical use is displayed in table 1.

There are 2,162 words in the VUAMC ( $N = 186,688$ ) that are connected to the three selected Sensory domains, which is just over one percent. There is substantial variation between the three Sensory concepts as a whole: Sight concepts ( $n = 1,193$ ) comprise

	<i>Non-metaphor</i>	<i>Metaphor</i>	<i>Total</i>
<i>General sensory</i>	322 (62.8)	191 (37.2)	513 (100.0)
<i>Sound</i>	348 (76.3)	108 (23.7)	456 (100.0)
<i>Sight</i>	843 (70.7)	350 (29.3)	1193 (100.0)
<i>Total</i>	1513 (70.0)	649 (30.0)	2162 (100.0)

Tab. 1: Frequencies (and row percentages) of three types of Sensory words, divided by non-metaphorical and metaphorical use

more than half of all Sensory concepts, while General Sensory concepts ( $n = 513$ ) and Sound concepts ( $n = 456$ ) account for the other other half in roughly equal measure. The relation between the three concept types and metaphor is significant ( $X^2_{(2)} = 21.68$ ,  $p = < 0.001$ ), Phi and Cramer's V indicating a modest effect size (0.10,  $p < .001$ ). General Sensory concepts display a greater proportion of metaphorical usage than average (37.2%), while Sound concepts display a smaller proportion of metaphorical usage (23.7%) than average; Sight concepts are roughly average in their metaphorical use (29.3%). The significant chi-square test indicates that this association between concept type and metaphor is statistically reliable. Since we do not have comparable figures for other languages and since the data as well as method of analysis are relatively specific, I do not want to speculate about their general significance. In the following sections we will take a closer look at the nature of all three sets of Sensory concepts. There we will make the link with their distribution across word classes and registers and attempt to understand how Sensory concepts relate to these essential dimensions of metaphorical language use.

Irrespective of this variation it is highly evident that Sensory concepts are much more metaphorical than all other concepts in the VUAMC: as mentioned above, the complete corpus has an average of 13.6% of metaphorical use (Steen et al., 2010a, b). The odds of Sensory concepts being metaphorical in language are about three times higher than the odds of all other concepts being metaphorical in language. The theoretical assumption that Sensory concepts may play a special and relatively frequent role in the grounding of metaphor in usage is hence supported by these corpus-linguistic data. It lends further credence to the cognitive-linguistic proposals in Hampe (2005), a collection of chapters on the relation between image schemas as the mental repository of Sensory-Motor experience on the one hand and abstract cognition, including metaphor-

ical cognition and language use, on the other. For instance, here is Mark Johnson, who writes:

The principal philosophical reason why image schemas are important is that they make it possible for us to use the structure of sensory and motor operations to understand abstract concepts and draw inferences from them. The central idea is that image schemas, which arise recurrently in our perception and bodily movement, have their own logic, which can be applied to abstract conceptual domains. (2005: 24)

At this point it may be useful to list the most frequent lexical units that are related to each of the three semantic domains of Sensory concepts and show their relation to metaphorical and non-metaphorical use (see table 2). It is striking that the ten most popular Sensory concepts for each of the three categories also account for the bulk of all sensory language use in the complete VUAMC: General Sensory 98 %, Sound 60 %, and Sight 86 %, respectively. It looks as if Sensory vocabulary is not highly varied but limited to a small number of frequently used basic terms. It is also striking that most of these lexical units are verbs, with nouns coming at some distance. Sensory language use apparently favours expression of sense experiences as actions, processes, events, or states. A third observation has to do with the differentiation between words that are preferably non-metaphorical (e. g., *tell, experience, hear, sound, ring, buzz, eye, watch*), words that are preferably metaphorical (e. g., *feel, catch, strike*), and words that are somewhat balanced between non-metaphorical and metaphorical use (e. g., *sense, pop, see, look*).

Thus, some Sensory language items typically appear in literal use, as may be illustrated with reference to *tell*:

- (1) ... but how can you **tell**?
- (2) ... and to **tell** you the naked truth ...
- (3) **Tell** me what you want.
- (4) ... you cannot **tell** one from the other ...
- (5) Please, I've found something I must **tell** you.
- (6) Doctor'll **tell** us.

Other Sensory language items typically appear in metaphorical uses, such as *catch* (only 9 is not metaphorical):

- (7) be up to the US and Canada to decide whether they want to face towards the Atlantic or Pacific or be **caught** between two great trading oceans

		<i>General Sensory (n = 513)</i>		<i>Sound (n = 456)</i>		<i>Sight (n = 1193)</i>			
		Not-M	Met	Not-M	Met	Not-M	Met		
1	tell	200	20	hear	74	6	see	270	159
2	feel	23	102	sound	51	2	look	226	64
3	experience	35	1	ring	24	4	eye	63	6
4	sense	13	23	buzz	22	0	watch	65	3
5	catch	9	22	strike	5	15	view	18	33
6	feeling	10	7	pop	11	8	miss	33	11
7	suffer	12	3	listen	15	0	notice	32	2
8	distinguish	5	5	noise	13	1	stare	13	3
9	greet	7	2	silence	12	0	glance	12	1
10	make + out	3	1	meow	11	0	observe	9	4
Total		317	186		238	36		741	286

Table 2: Lexical units and frequencies of top 10 Sensory concepts in non-metaphorical ('Not-M') and metaphorical ('Met') use

- (8) he **caught** the stomach-turning odour of decay
- (9) The people who get **caught** and imprisoned may not be a representative picture of all criminals
- (10) Delaney's stillness **caught** the attention of the others
- (11) She did and **caught** her breath

And yet other Sensory language items appear to be equally eligible for non-metaphorical (12 and 15) and metaphorical (13 and 14) use:

- (12) Because of this he had never **seen** the Oxford and Cambridge boat race until this year
- (13) They **see** themselves not as author and illustrator with separate roles but as a partnership of book-makers
- (14) so then I'm sure my colleagues will **see** the point of that
- (15) Otherwise the best place to **see** working trams has been the tram museum at Crich

Taken as a whole, all Sensory language seems to be roughly equally useful for the designation of concrete, genuine Sensory experiences as for more abstract experiences that are metaphorically expressed by means of Sensory vocabulary. This is typically not the case for all metaphor since the average proportion of all metaphorical language is 13.6%. At the same time, within this group, there is also some division of labour between non-metaphorical and metaphorical designation: some words seem to specialize into one direction whereas others prefer another direction, as was illustrated just now.

Worthy of note is the fact that the top 10 for Sound displays only 13.1 % metaphorical use; this suggests that the higher figure for metaphorical use for the complete Sound concept category is due to the remaining set of lexical units, which are used much less frequently than the ones in the top ten. These must be a different type of words, or so it seems, since they are used metaphorically more frequently. Further research will have to delve into this possible differentiation.

We now turn to the other main group of Sensory-Motor concepts, the Motor concepts. These also comprise three main categories for the purposes of this study: (a) Moving, Coming, and Going; (b) Pushing, Putting and Pulling; and (c) Location and Direction. Their association with metaphorical versus non-metaphorical use is displayed in table 3.

Motor concepts are much more frequent than Sensory concepts, exhibiting 24,353 in the data, which amounts to some 13 % of the entire VUAMC corpus. There is substantial variation between the incidence of the three distinct groups of Motor concepts: Location and Direction concepts comprise 72.9 % of all Motor concepts, while Moving, Coming and Going account for 17.1 % and Pushing, Putting and Pulling, for 10 %. The relation between these three distinct Motor concept categories and metaphor is significant ( $\chi^2_{(2)} = 51.43, p < 0.001$ ), Phi and Cramer's V revealing a small effect size (0.05). The Pushing, Putting and Pulling category has a greater proportion of metaphorical use (almost one in two) than the other two categories (just over one in three for Moving, Coming, and Going, and two in five for Location and Direction), which explains the statistically significant relation between concept category and metaphor.

	<i>Non-metaphor</i>	<i>Metaphor</i>	<i>Total</i>
<i>Moving,</i>	2,553	1,599	4,166
<i>Coming,</i>	(61.5)	(38.5)	(100.0)
<i>Going</i>			
<i>Pushing,</i>	1,278	1,135	2,423
<i>Putting,</i>	(53.0)	(47.0)	(100.0)
<i>Pulling</i>			
<i>Location,</i>	10,737	7,051	17,788
<i>Direction</i>	(60.4)	(39.6)	(100.0)
<i>Total</i>	14,568	9,785	24,353
	(59.8)	(40.2)	(100.0)

Table 3: Frequencies (and row percentages) of three types of Motor words, divided by metaphorical and non-metaphorical use

As a group, Motor concepts are much more frequently metaphorical than all other concepts, given the overall average of 13.6 % of all metaphorical use. The odds of Motor concepts being metaphorical in language use are no less than four times higher than the odds of all other concepts being metaphorical in usage. The theoretical assumption that Motor concepts may play a special role in the grounding of metaphor in usage is hence also supported by these corpus-linguistic data.

Below we will take a closer look at the nature of all three sets of Motor concepts in order to elucidate why Location and Direction is so much more frequent than the other groups. But a first indication of an answer may be provided by taking a look at the top 10 most frequent Motor concepts in metaphorical and non-metaphorical use (table 4).

		<i>Moving, Coming, Going</i> (n = 4,166)		<i>Pushing, Putting, Pulling</i> (n = 2,423)			<i>Location, Direction</i> (n = 17,788)		
		Not	Met	Not	Met		Not	Met	
1	get	468	243	take	83	222	to	3475	1025
2	go	551	146	place	180	86	in	1026	1904
3	come	149	121	put	86	112	for	1417	–
4	leave	79	47	move	56	29	on	323	780
5	move	56	29	turn	50	35	there	808	37
6	turn	50	35	hold	29	43	this	98	703
7	walk	78	4	bring	32	31	by	716	67
8	run	20	45	lead	18	45	about	12	394
9	follow	8	47	pull	40	10	right	266	3
10	return	30	22	set	17	29	where	188	62
Total		1489	539		581	642		8329	4975

Table 4: Lexical units and frequencies of top 10 Sensory concept, divided by non-metaphorical and metaphorical uses

The ten most popular Motor words within each category account for the following percentages of all Motor language use in the complete VUAMC: Moving, Coming, Going 48.7 %, Pushing, Putting, Pulling 50.5 %, and Location and Direction 74.8 %, respectively. In comparison with Sensory vocabulary, the first two Motor vocabulary categories (Moving, Coming, Going, and Pushing, Putting, Pulling) turn out to be much more varied, the top ten lexical units accounting for about half of the number of cases in the corpus. Location and Direction is more limited to a smaller number of frequently used basic terms.

The latter may clearly be related to the strikingly high numbers of prepositions, adverbs, and demonstratives emerging in that category, which recur throughout the

data, with a total lack of verbs and nouns. Motor language involving Location and Direction most frequently concerns expression of sense relations between entities and processes, whereas Motor language involving movement and exerting force is more like the Sensory concepts and concerns actions, processes, events and states predominantly designated by verbs and their nominal derivations.

A third observation that can be made has to do with the different distribution than in Sensory words, which are preferably non-metaphorical, metaphorical or mixed. Most Motor language is roughly equally useful for the designation of concrete Motor experiences as for other experiences that are metaphorically derived and expressed by means of Motor vocabulary. Note that the lack of metaphorical use of 'for' is an artefact of the annotation method used in our corpus analysis, where both 'of' and 'for' were taken as too semantically bleached to display reliably recognizable contrasts between non-metaphorical and metaphorical uses (Steen et al., 2010a).

It should be noted that the top 10 for Moving, Coming, Going displays only 26.7 % metaphorical use; this suggests that the higher figure for metaphorical use for the complete Moving, Coming, Going concept category of 38.5 % is due to the remaining set of lexical units that are used much less frequently but, apparently, more often metaphorically. As with the Sound category above, this may be a different type of words meriting further exploration. Another interesting observation is the fact that the top 10 Pushing, Putting and Pulling words are used more frequently metaphorically than not metaphorically. This is a unique finding so far and also requires further inspection in the future. Both of these findings in this exploratory study suggest important avenues for further research.

There is a substantial difference between the frequencies of Sensory concepts and Motor concepts in all of the data, Motor concepts occurring about eleven times as frequently as Sensory concepts. Is it possible that this is an indication that motion is less abstract and even more basic, as it were, than sensory experience, which typically involves some associated form of cognitive response (cf. Grady, 2005)? We have also seen that both Sensory concepts and Motor concepts interact with metaphor in different ways than all other concepts: both Sensory and Motor concepts are much more frequently used metaphorically in language than all other concepts, while Motor concepts are even more frequently metaphorical than Sensory concepts. There also appears to be a substantial difference between the frequencies of the various subcategories of both the Sensory concepts and the Motor concepts, with additionally variable relationships with metaphorical usage: there is a rank order from General Sensory through Sight to Sound

concepts which differ significantly from each other in their propensity for metaphorical use; and there is a three-way distinction between Pushing Putting and Pulling (highly metaphorical) versus the other two Motor categories (less highly metaphorical), one of which, however (Location and Direction) is different from the other (Moving, Coming and Going) on account of its extraordinarily high overall frequency as well as its different types of word classes in the top ten. In other words, almost every Sensory-Motor category behaves differently than the other ones, suggesting that each type of Sensory-Motor concept has properties of its own.

This warrants taking a closer look at the nature of each subcategory of Sensory-Motor concepts in order to try to understand why Motor concepts may be so much more frequent than Sensory concepts, why Motor concepts invite metaphorical use more often than Sensory concepts, and what may be the causes behind the different frequencies of each of the subcategories of Sensory-Motor concepts with further variable metaphorical use within Sensory concepts and Motor concepts as main groups. Tentative explanations of these observations will be sought now by examining the nature of word classes of the metaphorical and non-metaphorical uses of the various Sensory-Motor concept categories (section 3.2) and their relation to the four registers of academic texts, news text, fiction and conversations (section 3.3).

### **3.2 Sensory-Motor Concepts, Metaphor and Word Class**

Can the high metaphorical usage of the Sensory concepts and even more of the Motor concepts in comparison with all other concepts be understood with reference to particular word classes? Since previous work has shown a relationship between metaphor and word class, word class variation between Sensory-Motor concepts and Other concepts may also play a role in the variable metaphorical use of the three groups of concepts. It is the aim of this section to explore this relationship impressionistically for the most obvious understandable patterns. We shall also examine whether these main effects of word class on metaphorical usage of Sensory-Motor concepts are compounded by further interactions with subcategories of each Sensory-Motor concept or not. If there are interactions, the overall picture needs further refined and a more differentiated interpretation. I will therefore now check the relation of word class and metaphor to each of the three separate subcategories of Motor concepts and of Sensory concepts.

For this purpose, only the metaphorical uses of the General Sensory concepts, Sound concepts, and Sight concepts in our data will be related to word class (Adjective, Adverb,



Determiner, Noun, Preposition, Verb, and Remainder). Table 5 displays the findings. Frequencies and percentages only indicate the proportion of metaphorical use *within* a word class for a particular Sensory category, all non-metaphorical uses having been omitted from the table.

	<i>Adj</i>	<i>Adv</i>	<i>Noun</i>	<i>Verb</i>	<i>Remain</i>	<i>Total</i>
<i>General Sensory</i> ( <i>n</i> = 514)	0 (0)	–	34 (39.5)	157 (36.9)	–	191 (37.2)
<i>Sound</i> ( <i>n</i> = 456)	13 (40.6)	0 (0)	33 (23.4)	62 (26.4)	0 (0)	108 (23.7)
<i>Sight</i> ( <i>n</i> = 1,198)	3 (15.8)	0 (0)	84 (28.7)	263 (29.9)	–	350 (29.3)
<i>Total</i> ( <i>N</i> = 2,162)	16 (30.8)	0 (0)	151 (29.0)	482 (31.3)	0 (0)	649 (30.0)

Table 5: Frequencies (and percentages) of metaphor related words per word class for three groups of Sensory concepts

Systematic statistical analysis by means of a series of comparable chi-square tests was not feasible because of the number of cells with zero observations, and collapsing categories would have led to complications. But visual inspection confirms that Verbs and Nouns account for the bulk of the data (in total 482 Verbs plus 151 Nouns makes 633 out of 649), with Verbs occurring about three times as often as Nouns. In itself this is a remarkable proportion, as in general verbs display 18.7 % metaphorical usage, as opposed to nouns 13.3 % (e. g. Herrmann, 2013). Apparently, metaphorical uses of Sensory, Sight and Sound words are mostly verbal, followed at great distance by nominal, which is completely atypical in comparison with overall tendencies of the relation between word class and metaphorical use.

Variation in metaphorical usage per Sensory category seems to be largely due to variation in metaphorical use of the Verb class: General Sensory concepts have the highest metaphorical use because Verbs account for 30.5 % of the data (157 out of 514). Sight concepts follow suit because metaphorically used Verbs explain 22 % of the data (263 out of 1,198). And Sound concepts have the lowest proportion of metaphorical use because metaphorical Verbs comprise a mere 13.6 % of the data (62 out of 456). Throughout these patterns, metaphorical nouns consistently account for some 7 % of the totals and do not affect the overall score for metaphorical use in the distinct three Sensory categories.

The distribution of metaphorically used words expressing Sensory concepts hence mostly depends on the varying popularity of distinct categories of Sensory verbs having to do with General Sensory experiences, Sound, and Sight. Since Verbs as well as Nouns generally tend to have a higher metaphorical use than average (Steen, 2010 a, b), part of the high metaphorical use of the Sensory concepts is also explained by the fact that this category is dominated by Verbs and Nouns. However, at the same time, average metaphorical use of all Verbs and Nouns is substantially lower than 30 %: if this can be shown to be a significant difference in more encompassing statistical testing, this would suggest that Sensory Noun and Verbs are a special category of lexis eliciting metaphorical use more often than all other Verbs and Nouns. Sensory experience expressed in language may then indeed be regarded as a popular basis for metaphorical meaning on the basis of its ability to conceptualize the abstract via concrete embodied experiences.

Let us now turn to Motor concepts and relate metaphorical use of (a) Moving, Coming and Going concepts, (b) Pushing, Putting and Pulling concepts, and (c) Location and Direction concepts to word class again (Adjective, Adverb, Determiner, Noun, Preposition, Verb, and Remainder). Table 6 displays the findings in the same way as table 5: frequencies and percentages only indicate the proportion of metaphorical use *within* a word class for a particular Motor category, all non-metaphorical uses having been omitted from the table.

	Adj	Adv	Det	Noun	Prep	Verb	Remain	Total
Moving, Coming, Going ( <i>n</i> = 4,166)	9 (37.5)	0 (0.0)	–	323 (43.3)	–	1267 (37.6)	0 (0.0)	1599 (38.5)
Pushing, Putting, Pulling ( <i>n</i> = 2,423)	2 (10.0)	–	–	229 (39.0)	–	904 (50.1)	0 (0.0)	1135 (47.0)
Location, Direction ( <i>n</i> = 17,779)	92 (21.9)	682 (33.6)	701 (87.7)	626 (44.3)	4615 (52.1)	280 (51.6)	55 (1.5)	7051 (39.6)
Total ( <i>N</i> = 24,368)	103 (22.2)	682 (33.5)	701 (87.7)	1178 (42.9)	4615 (52.1)	2451 (42.9)	55 (1.5)	9785 (40.2)

Table 6: Frequencies (and column percentages) of metaphor related words per word class for three groups of Motor concepts

Table 6 immediately throws into relief the special role of Prepositions for all Sensory-Motor concept research: they increase the total metaphorical use of all Location and Di-

rection concepts by 4615 cases, to the strikingly high figure of 9785. Since Prepositions do not play a role in the other two Motor concept categories, nor in all Sensory concepts, as we have seen, Location and Direction Prepositions might have to be treated as a separate category. They account for almost half of the inordinately high proportion of metaphorical use of Motor concepts in comparison with Sensory concepts as well as all other concepts. This now appears to be a specific manifestation of the natural connection between the concepts of Location and Direction on the one hand and Prepositions on the other. It does not appear to be characteristic of the behavior of Sensory-Motor concepts in general.

Statistical analysis was not feasible without raising complications again. Yet visual inspection shows that Location and Direction concepts display a different usage of Nouns and Verbs than the other two Motion concepts. Where Verbs and Nouns account for 99.2% of all Moving, Coming, and Going concepts as well as of all Pushing, Putting and Pulling concepts (which is comparable to what happens in Sensory concepts), Verbs and Nouns comprise a meager 12% in the Location and Direction concepts. Vice versa, Location and Direction is the only Sensory Motor concept category that makes substantial use of Adverbs and Determiners, too—as was already suggested by the top ten frequent words in table 4 above. Perhaps it is therefore not just Location and Direction Prepositions, but all Location and Direction lexis which ought to be treated as a separate category in the study of Sensory-Motor concepts.

Focusing on the two remaining categories of Motor concepts, that is, Pushing, Putting and Pulling as well as Moving, Coming and Going, these seem to exhibit rather comparable patterns of word class distribution. Both largely involve Verbs and Nouns, with Verbs dominating over Nouns in both categories. This is roughly comparable to the situation in Sensory concepts. It should not come as a surprise that both Pushing, Pulling and Putting concepts as well as Moving, Coming and Going concepts seem to be naturally related to the word class of Verbs, and this explains why a good deal of the metaphorical usage of these Motor concepts is related to the variable incidence of this one word class category. This again accounts for part of the higher metaphorical use of Motor concepts, given the generally high metaphorical use of verbs and nouns, but it also leaves another portion unexplained which apparently has to do with the specific nature of Motor Verbs and Nouns as apt source domains for frequent metaphorization of the abstract by the concrete.

Location and Direction concepts display behavior which is not shared by the other two Sensory-Motor categories examined in these data. Whereas initially it seemed nat-

ural to include Location and Direction under Motion and Motor concepts, this may now require further theoretical reflection. Moving, Coming and Going concepts resemble Pushing, Putting and Pulling concepts when it comes to their lexical expression in usage, Verbs and at some distance Nouns dominating the scene. Location and Direction display a completely different profile and are the only category that is heavily dependent on other word classes than Verbs and Nouns, with Prepositions, Adverbs and Determiners instead being most prevalent.

In sum, the relation between metaphor and Sensory-Motor concepts may be partly explained with reference to their interaction with word class. For the 2,168 Sensory concepts in the corpus, there are basically just two word classes involved, Verbs clearly dominating the picture, accounting for almost three quarters of all Sensory concepts. What is more, one third of these Sensory Verbs are used metaphorically, which is an inordinately high percentage: Sensory Verbs apparently lend themselves to metaphorical usage very easily. Likewise, Sensory Nouns account for the remaining quarter of all Sensory concepts, with a proportion of over 40 % being used metaphorically, which is also strikingly high.

For the 24,566 Motor concepts, we have a situation that is comparable to the Sensory category for two of the three Motor categories: Moving, Coming, and Going, and Pushing, Putting and Pulling. There is one category that is starkly different, Location and Direction: there Prepositions play a deviant and prominent role, accounting for more than one third of all Motor concepts in the complete corpus. Moreover, metaphorical use of Motor Prepositions is extraordinarily high, comprising over 50 % of all Motor Prepositions. Prepositions hence account for 4,615 cases out of all 9,785 Motor concepts that are metaphorical. With the additionally different behavior of Adverbs and Determiners as well as Verbs and Nouns in the Location and Direction category, a case can be made for separating this category from the other two Motor concepts.

We already saw that Sensory concepts appear to be rather different than Motor concepts, but we may now add that perhaps all Sensory-Motor concepts ought to be seen as comprising not two but three rather distinct groups of concepts: Sensory Concepts, Motor concepts (including Moving, Coming, Going, and Pushing, Putting, Pulling), and Location and Direction concepts. This is based on the radically different relation between the various categories and word classes. Partly as a result of this, their overall frequency in language use varies considerably too: 1.16 % for Sensory concepts, 3.55 % for Motor concepts, versus 9.55 % for Location and Direction, respectively. The interaction between Sensory-Motor concepts and metaphor is clearly affected by the inter-

action between metaphor and word class. Apart from this, in the other two Motor concept categories, Verbs and Nouns are more frequently metaphorical in comparison with Sensory Verbs and Nouns (roughly over 40 % in Motor concepts versus about 30 % in Sensory concepts)—why Motor concepts would elicit more metaphorical use than Sensory concepts is an intriguing question. With a reference to Grady (2005), I have raised the question whether they might be less abstract and involve less mental response.

### **3.3 Sensory-Motor Concepts, Metaphor and Register**

Can the relatively high metaphorical usage of the Motor concepts and the Sensory concepts be related to the increased use of Sensory-Motor concepts in specific registers, in comparison with other concepts? Since previous work has shown a relationship between metaphor and register, register variation in Sensory-Motor concepts may also interact with the metaphorical use of various groups of concepts. We shall now see whether these main effects of register on metaphorical usage of Sensory-Motor concepts can be refined by checking each of the separate subcategories of Motor concepts and Sensory concepts. We shall begin with the Sensory concepts again.

The overall distribution of the Sensory concept lexis across the four registers turns out to be very uneven. In the complete VUAMC corpus, the four registers are about equally large, averaging about 47,000 words each, which would predict a 25 % division of the Sensory concepts across the registers by chance. This is not the case: Fiction has a high 40 % of all Sensory concepts, followed by Conversation, which is close to average with 28.1 %, while News (16 %) and Academic texts (15.9 %) are low. One interpretation of this finding is that Fiction has an emphasis on Sensory experience that is there for artistic reasons, making experience more palpable, as opposed to the more abstract concerns of News and Academic texts.

Table 7 displays the frequencies and percentages of only the metaphorical words per register for each of the three Sensory concept categories. The overall pattern of metaphorical usage in the complete VUAMC corpus manifested the following percentages for all lexis, Sensory-Motor and otherwise: Academic 18.5 %, News 16.4 %, Fiction 11.7 %, and Conversation 7.7 % (Steen et al., 2010a, b). From the previous sections we already know that there is a higher percentage of metaphorical use for Sensory concepts than average, but now we can observe two further conspicuous differences when we turn to the relation between metaphor and register for Sensory concepts. First of all, there seems to be a split between Academic and News texts on the one hand and

Fiction and Conversation on the other, with Academic and News texts having double or more than double the number of metaphorical uses than Fiction and Conversation. And secondly, where Sensory concepts in Academic and News texts are in the same ordering from more to less metaphorical as may be observed for all concepts, Fiction and Conversation are in roughly the same position, Fiction having less metaphor and Conversation having more metaphor than expected when compared with the general pattern in the complete corpus. Upon close inspection this is solely due to what happens in the Sight category, which exerts a relatively great effect on the overall patterns because it accounts for half of all Sensory concept cases: in the General Sensory and Sound categories, the rank order between the registers regarding metaphorical use is in accordance with the overall pattern in the complete corpus. What we are dealing with, therefore, is a three-way interaction between metaphor, concept category and register, which moreover has to be seen against the background that Sensory concepts are proportionately much less frequent in Academic and News texts as opposed to Fiction where they are much more frequent. The relation between Sensory concepts and metaphor in usage is thus rather complicated when we examine it from the perspective of genre, which clearly affects their interaction.

	<i>Academic</i>	<i>News</i>	<i>Fiction</i>	<i>Conversation</i>	<i>Total</i>
<i>General Sensory</i> ( <i>n</i> = 514)	44 (46.8)	46 (52.3)	66 (33.5)	35 (26.1)	191 (37.2)
<i>Sound</i> ( <i>n</i> = 456)	19 (59.4)	35 (36.1)	40 (19.3)	14 (11.7)	108 (23.7)
<i>Sight</i> ( <i>n</i> = 1,198)	131 (60.1)	68 (42.0)	70 (15.2)	81 (22.9)	350 (29.3)
<i>Total</i> ( <i>N</i> = 2162)	194 (56.4)	149 (42.9)	176 (20.4)	130 (21.4)	649 (30.0)

Table 7: Frequencies (and percentages) of metaphor related words per register for three groups of Sensory concepts

For each of the three Sensory concepts, the relation between metaphor and genre was tested by means of a two-way chi-square test of significance. All tests returned significant results: for General Sensory concepts,  $X^2_{(3)} = 20.46$ ,  $p < 0.001$ , Phi and Cramer's  $V = 0.20$ ; for Sound concepts,  $X^2_{(3)} = 42.57$ ,  $p < 0.001$ , Phi and Cramer's  $V = 0.31$ ; and for Sight concepts,  $X^2_{(3)} = 163.14$ ,  $p < 0.001$ , Phi and Cramer's  $V = 0.37$ . Standardized residuals revealed significant effects of the categories furthest removed from the expected frequencies, such as high metaphoricity in News for general Sensory concepts, high metaphoricity in Academic texts and News texts for Sound, and high

metaphoricity for Academic texts but low metaphoricity for Fiction in Sight. The most prominent differences between registers manifested for metaphor in each of the three Sensory concept categories are statistically reliable.

For each of the four genres, the relation between metaphor and Sensory concept category was also tested by means of a two-way chi-square test of significance. Two tests returned significant results: for Fiction,  $X^2_{(2)} = 28.61$ ,  $p < 0.001$ , Phi and Cramer's  $V = 0.18$ ; and for Conversation,  $X^2_{(2)} = 9.03$ ,  $p = 0.01$ , Phi and Cramer's  $V = 0.12$ . Standardized residuals revealed significant effects of the metaphorical use of Sound categories in Conversation, which is extremely low compared with the other two concept types in Conversation; of metaphorically used General Sensory concepts in Fiction, which is very high within Fiction, as well as of metaphorically used Sight concepts in Fiction, which is low within Fiction. For Academic texts and News texts, chi square was not significant, although revealing a tendency towards significance ( $p < 0.1$ ): all Sensory concept categories are used in roughly comparable measure in both of these registers.

For Sensory concepts, we see a clear split between registers. The abstract registers of Academic and News texts have a comparatively low percentage of Sensory concepts that at the same time are used metaphorically relatively very often. In Academic texts, Sensory concepts are used metaphorically even more than half of the times, which is a unique finding. The more concrete registers of Conversation and Fiction have an understandably high proportion of Sensory concepts that at the same time are used metaphorically much less frequently than in Academic and News Texts, making Conversation and Fiction even more concrete. For instance, in our data the verb *to feel* is used non-metaphorically only in Conversation and Fiction (*feel the cold, feel warm*), not in Academic and News, where it is always used metaphorically. It is also true, however, that Sensory concepts in Fiction and Conversation are still used metaphorically twice as often as all metaphorical lexis taken together in the entire VUAMC corpus: in the overall corpus, Conversation has 7.7 % metaphor, and Fiction 11.7 % metaphor, whereas for Sensory language use, these percentages climb to over 20 %. This may also be due to the relative frequency of such constructions as *feel anxious, guilty, uneasy*, and so on, which feature quite large in Conversation and Fiction. All of this is still a powerful indication that Sensory concepts do play a special role in affording metaphorical language and perhaps conceptualization.

We will now do the same analysis for Motion concepts. We will relate metaphorical use of (a) Moving, Coming and Going concepts, (b) Pushing, Putting and Pulling concepts, and (c) Location and Direction concepts to the four registers. Table 8 dis-

plays only the metaphorical frequencies and percentages of the Motion concepts (with metaphorical and non-metaphorical totals listed under *n* in the first column).

	<i>Academic</i>	<i>News</i>	<i>Fiction</i>	<i>Conversation</i>	<i>Total</i>
<i>Moving, Coming, Going</i> ( <i>n</i> = 4,166)	410 (70.3)	460 (55.1)	343 (30.4)	386 (24.1)	1599 (38.5)
<i>Pushing, Putting, Pulling</i> ( <i>n</i> = 2,423)	347 (65.7)	384 (61.6)	265 (34.6)	139 (28.1)	1135 (47.0)
<i>Location, Direction</i> ( <i>n</i> = 17,779)	2786 (54.0)	1933 (41.9)	1311 (31.4)	1021 (26.6)	7051 (39.6)
<i>Total</i> ( <i>n</i> = 160,167)	3543 (56.5)	2777 (45.8)	1919 (31.6)	1546 (26.1)	9785 (40.2)

Table 8: Frequencies (and percentages) of metaphor related words per register for three groups of Motor concepts

In contrast with the Sensory concepts, the overall distribution of Motor concept lexis across the four registers is even. The percentages of Motor concepts across the four registers of Academic texts, News texts, Fiction, and Conversation are 25.8, 24.9, 25.0, and 24.4, respectively. This is in accordance with the size of the four sub corpora, and according to what might be expected according to chance. It throws into relief the special value of the previous finding of the uneven distribution of Sensory concepts and suggests that there may be a difference between the roles of Sensory and Motor concepts that needs to be examined more closely.

The overall rank order of metaphorical usage across genres in the complete corpus is also reflected in the distribution of the Motor concepts across the four genres: Academic has the highest percentage (56.5), followed by News (45.8) and Fiction (31.6), with Conversation at the low end of the scale (26.1). We already knew that there is a higher percentage of metaphorical use for Motor concepts than average, but we can now see that this holds for all registers, and that the mutual difference in metaphorical usage between the four genres may be somewhat greater than for all metaphor use. This will have to be examined in future research with more encompassing statistical tests.

Next, when we examine the difference between Location/Direction concepts and the other two sets of Motor concepts, it looks as if there is an interaction between concept type and register: both Academic texts and News texts display a rather high frequency of metaphorically used Moving, Coming and Going concepts as well as Pushing, Putting, and Pulling concepts, while all other concepts seem to be distributed across the



four registers according to chance. Two series of two-way statistical tests by means of chi-square showed whether these first impressions were reliable.

For each of the three Motor concepts, the relation between metaphor and genre was tested by means of a two-way chi-square test of significance. All tests returned significant results: for Moving, Coming, and Going,  $X^2_{(2)} = 519.23$ ,  $p < 0.001$ , Phi and Cramer's  $V = 0.35$ ; for Pushing, Putting and Pulling,  $X^2_{(2)} = 246.69$ ,  $p < 0.001$ , Phi and Cramer's  $V = 0.32$ ; for Location and Direction,  $X^2_{(2)} = 843.75$ ,  $p < 0.001$ , Phi and Cramer's  $V = 0.22$ . Standardized residuals revealed significant effects of all categories in each of the two-way interactions, suggesting that no single category crossing two variables behaved according to expectation by chance.

For each of the four genres, the relation between metaphor and Sensory concept category was also tested by means of a two-way chi-square test of significance. Two tests returned significant results: for Academic,  $X^2_{(2)} = 77.24$ ,  $p < 0.001$ , Phi and Cramer's  $V = 0.11$ ; and for News,  $X^2_{(2)} = 119.52$ ,  $p = 0.01$ , Phi and Cramer's  $V = 0.14$ . Standardized residuals revealed significant effects of all categories in each of these two two-way interactions. For Fiction and Conversations, chi square was not significant, although for Conversation a tendency towards significance was revealed ( $p < 0.1$ ).

In sum, each of the registers differs from the others when it comes to their use of each of the distinct Motor concepts. Moreover, Academic and News texts display different usages of each of the three Motor concepts within their own register. In Academic texts, there is a stunning 70 % of metaphorical usage of Moving, Coming, and Going lexis, followed by 65.7 % of metaphorical usage for Pushing, Putting, and Pulling. In News texts, Pushing, Putting and Pulling leads the way, with 65.1 %, followed by Moving, Coming and Going, with 55.1 %. Examples would include metaphorical uses of *take* in academic writing such as *take issue with*, *take an example*, *take a more mature attitude*, *take note of*, *take the view*, and so on. This is to be contrasted with metaphorical usage of both concept categories in both Fiction and Conversation, where percentages range between 24.1 % and 34.6 %. The verb *take* is used in those registers relatively more often as a verb that involves the taking of a concrete object. Location and Direction have a much lower metaphorical percentage in Academic and News texts, while they are relatively comparable to the other concept categories in Fiction and Conversation.

These are clear quantitative indications that the metaphorical use of Motor concepts in language cannot be treated as one uniform phenomenon, but that more work needs to be done on the relation between Motor concepts, metaphor, and register. A close examination of the cases involved is the next step that needs to be taken.

The relation between Sensory-Motor concepts and metaphor in language is clearly affected by register. Sensory concepts have an uneven distribution across registers, with Fiction clearly favoring Sensory concepts (in order to create a fictional world) while Academic and News texts do not; Motor concepts, by contrast, are evenly distributed. The language of fiction therefore has a higher Sensory-Motor quality than than other registers, while the language of Academic and News texts is less 'Sensory-Motory.' At the same time, Academic and News texts throughout favor metaphorical use of both Sensory and Motor concepts, even in absolute terms. This accords with their abstract nature and contrasts with the predominance of non-metaphorical use of Sensory-Motor terms in Fiction and Conversation. In addition, since Academic and News texts tend to be more metaphorical than Fiction and Conversation overall, it can now be seen that Sensory-Motor terms make a substantial contribution to this two-way distinction between the four registers.

#### **4 Discussion**

The relation between Sensory-Motor concepts and metaphor in usage has been on the agenda of cognitive linguists, psychologists, and scientists in general for some time. Theoretical motivation for this interest is amply available, but the present study is the first corpus-linguistic exploration of this relationship. Even though the study is partial and tentative it has revealed some new tendencies which require further scrutiny on the basis of more encompassing research, which is currently undertaken in our lab.

The most important observation is that Sensory-Motor concepts on the one hand do display a higher degree of metaphorical use than all other concepts, but that on the other hand this relationship is not uniform but variable across all categories as well as groups of categories that can be distinguished between the Sensory-Motor concepts included in this study. Thus, Motor concepts are eleven times more frequent than Sensory concepts; Sight concepts are twice as frequent as Sound concepts and general Sensory concepts; and Location and Direction concepts are an entirely different group of Sensory-Motor concepts than all others, comprising three quarters of all Motor concepts and having a radically different word class profile than all other five concept categories. In particular, all other Sensory-Motor concepts are dominated by verbal and at some distance nominal expression, while Location and Direction are based on prepositions, adverbs and demonstratives. Further research including other Sensory-Motor concepts clearly

needs to throw more light on the diversity of this group of concepts in order to establish its internal coherence.

The second most important observation is that despite this internal variation, all Sensory-Motor concepts are much more often metaphorical than all other concepts. This is consistent with the idea that Sensory-Motor knowledge has a special role to play in the metaphorical conceptualization of our experience. The ground of this idea is the assumption that Sensory-Motor knowledge is the most specific and best-differentiated concrete knowledge we have which can then be used as a model for less specific, less differentiated more abstract knowledge, for instance about social relations and processes (Sight for Understanding) or temporal and abstract processes (Motion for Change). The details of these varying relationships can now be studied in context with reference to a substantial set of natural language materials.

A third point emerging from this study is the role of register. Sensory-Motor concepts are not just more frequently related to metaphor in usage, perhaps mediated via obvious distinctions between word classes; these relations are also exploited to a greater or lesser extent in distinct situations of language use. We saw a clear distinction between, on the one hand, the more abstract registers of Academic and News texts, and, on the other hand, the more concrete registers of Fiction and Conversation. Sensory concepts were dispreferred in the former two, but those Sensory concepts that were used there were massively metaphorical. Sensory concepts were preferred in Fiction and Conversation, but their use was much less often metaphorical than in Academic and News, even if it was still more metaphorical than the average metaphorical use of all other concepts in Fiction and Conversation.

Motor concepts displayed a different relationship with register. They were distributed evenly across all registers but their metaphorical use went down from Academic through News and Fiction to Conversation. Metaphorical use of Sensory-Motor concepts is clearly promoted in Academic and News texts and less so in Fiction and Conversation.

The relation between Sensory-Motor concepts and metaphor in usage is therefore no simple one. It involves a four-way interaction between Sensory-Motor concepts, metaphor, word class, and register. This paper has only begun to sketch the possible outlines of this complex picture. I hope that it will provide a useful inspiration for more encompassing as well as thorough and detailed work in the future.

## 5 References

- Biber, D. and S. Conrad (2009). *Register, genre and style*. Cambridge: Cambridge University Press.
- Dorst, A. G. (2011) *Metaphor in Fiction: Language, Thought, and Communication*. Oisterwijk: BOX Press.
- Gibbs, R. W., jr. (2006). *Embodiment and cognitive science*. Cambridge: Cambridge University Press.
- Grady, J. (2005). Image schemas and perception: Refining a definition. In Hampe (2005), pp. 35–56.
- Hampe, B. (Ed.) (2005). *From perception to meaning: Image schemas in cognitive linguistics*. Berlin, New York: Mouton de Gruyter.
- Herrmann, J. B. (2013). *Metaphor in Academic Discourse: Linguistic Forms, Conceptual Structures, Communicative Functions and Cognitive Representations*. Utrecht: LOT dissertation series, 333.
- Johnson, M. (2005). The philosophical significance of image schemas. In Hampe (2005), pp. 15–34.
- Kaal, A. A. (2012). *Metaphor in Conversation*. Oisterwijk: BOX Press.
- Krennmayr, T. (2011) *Metaphor in Newspapers*. Utrecht: LOT dissertation series, 276.
- Krennmayr, T., and Steen, G.J. (In press). VU Amsterdam Metaphor Corpus. In N. Ide and J. Pustejovsky (Eds.), *Handbook of Linguistic Annotation*. Berlin: Springer, 2014.
- Lakoff, G., & Johnson, M. (1980). *Metaphors we live by*. Chicago: Chicago University Press.
- Lakoff, G., & Johnson, M. (1999). *Philosophy in the flesh: The embodied mind and its challenge to western thought*. New York: Basic Books.
- Mandler, J. M. (2004). *The foundations of mind: Origins of conceptual thought*. Oxford: Oxford University Press.
- Pasma, T. (2011). *Metaphor and register variation: The personalization of Dutch news discourse*. Oisterwijk: BOXpress.
- Rayson, P. (2009). Wmatrix: a web-based corpus processing environment, Computing Department, Lancaster University. <http://ucrel.lancs.ac.uk/wmatrix/>.
- Steen, G. J., Dorst, L., Herrmann, B., Kaal, A., Krennmayr, T., & Pasma, T. (2010a). *A method for linguistic metaphor identification: From MIP to MIPVU*. Amsterdam / Philadelphia: John Benjamins.
- Steen, G. J., Dorst, A. G., Herrmann, J. B., Kaal, A., & Krennmayr, T. (2010b). Metaphor in usage. *Cognitive Linguistics*, 21(4), 757–788.

RALF NAUMANN

## Dynamics in the Brain and Dynamic Frame Theory for Action Verbs

Ralf Naumann  
Heinrich-Heine-University Düsseldorf  
Institut for Language and Information

naumann@phil.hhu.de

### Abstract

In this article we outline a theory of action verbs that combines a modality-independent (or abstract) conceptual component with a modality-specific one. Verbs as concepts are interpreted as ranked sets of nuclei structures in the sense of Moens and Steedman (1988). This information is stored in the middle temporal gyrus (Bedny and Caramazza 2011). Besides being amodal, this information is underspecified w.r.t. a particular way in which the action is executed (*grasp a needle* vs. *grasp a barbell*), i. e. it is not grounded in a particular situation. This underspecification can in general only be resolved if the type of object undergoing the change (*needle* vs. *barbell*) is known. Following Willems et al. (2009), this grounding is explained as an *implicit simulation* in premotor cortex, that is a preenactment of the action which makes it possible to predict the way in which the action evolves and which is distinct from explicit (motor) imagery.

## 1 Theories of grounded cognition: evidence and problems<sup>1</sup>

According to Zwaan and Kaschak (2008: 368), ‘language is a sequence of stimuli that orchestrate the retrieval of experiential traces of people, places, objects, events, and actions.’ They illustrate this view of language with an example taken from Barsalou (1999). When reading the sentence *John removed an apple pie from the oven*, a comprehender understands this sentence by retrieving past experiences involving persistent objects like apple pies and ovens as well as events of removing something, for instance, an apple pie from an oven. These traces usually include both motor experiences such as lifting the pie and feeling its weight and perceptual experience like seeing and smelling the pie and feeling the heat coming out of the oven. Similarly, when processing the verb *throw* or the sentence *Bill throws the ball*, a speaker mentally simulates an action of throwing (Pulvermüller 2005). On this view, ‘the understanding of action-related sentences implies an internal simulation of the action expressed in the sentences, mediated

---

<sup>1</sup> The research was supported by the German Science Foundation (DFG) funding the Collaborative Research Center 991.

by the activation of the same motor representations that are involved in their execution' (Buccino et al. 2005: 361). On this view, understanding words and other linguistic items is based on the same neural substrate as imagining the actions and objects described by those linguistic expressions (Gallese and Lakoff 2005: 456). For example, Gallese and Lakoff argue that one can understand the sentence *Harry picked up the glass* only if one can imagine picking up a glass or seeing someone picking up a glass. This view is in line with the idea of Hebbian learning: neuronal correlation is mapped onto connection strength. As formulated by Hauk et al. (2004: 301): 'If word forms frequently co-occur with visual perceptions (object words), their meaning-related activity may be found in temporal visual areas, whereas action words frequently encountered in the context of body movements may produce meaning-related activation in the frontocentral motor areas'. If a verb refers to actions and events that are typically performed with the face, arm or leg, neurons processing the word and those processing the action described by that word frequently fire together and thus become more strongly linked. As a result, word-related networks overlap with motor and premotor cortex in a somatotopic fashion (Pulvermüller 1999). On this *semantic somatotopy* view of meaning, being able to simulate executing an action of the type denoted by the verb is constitutive of the verb's meaning.

Empirical evidence for theories of grounded (or embodied) cognition comes from neuroimaging studies using fMRI or ERP. When action words are processed, there is effector-specific activation of motor areas that is somatotopically organized. For example, a leg-related word like *kick* activates dorsal areas, where leg actions are represented and processed, whereas arm-related words such as *pick* or face-related words such as *lick* activate lateral or inferior frontal motor areas, respectively. Similarly, when reading or viewing the noun *hammer*, the hand and not the foot area of the motor system is activated.

Such theories of embodied cognition make a number of empirically testable predictions: (i) understanding an action verb and imagining performing that same action rely on the same neural tissue, in particular premotor cortex (Willems et al. 2009: 2388), (ii) understanding action verbs is primarily based on early, modality-specific, sensory-motor brain regions (Bedny and Caramazza 2011: 82) and (iii) these sensory-motor brain regions are automatically engaged during word comprehension (Bedny and Caramazza 2011: 82).

The first problem for theories of grounded cognition is that many neuroimaging studies failed to observe any increased activity for action-verbs anywhere in the motor

system (Bedny and Caramazza 2011: 87). A notable exception is the study by Willems et al. (2009). In an fMRI study they examined whether implicit stimulations of actions during language understanding involve the same cortical motor regions as explicit motor imagery. The participants were presented with verbs that are either related to actions that are usually executed with the hand, like *throw*, or with verbs that are not related to this body part, like *kneel*. In order to control for spurious activation due to explicit imagery, there were two different tasks: participants either read the verbs (lexical decision task LD) or they actively imagined performing the actions denoted by these verbs (imagery task IM). Contrary to earlier results, they found a double dissociation. Primary motor cortex showed effector-specific activation during imagery, but not during the lexical decision task. For the premotor area they found out that there was effector-specific activation that distinguished between manual and non-manual verbs, both in LD and in IM. But importantly, there was no overlap or correlation between regions activated during the two tasks. More precisely, portions of BA6 and BA4 that were defined on the basis of effector-specific activity during the IM task showed no such activity during LD. Similarly, regions in BA4 and BA6 that showed effector-specific activity during LD showed no such activity during IM. The authors conclude: “These double dissociations show that implicit motor simulation and explicit motor imagery do not necessarily engage the same neural tissues in premotor and primary motor cortices and by inference may not include the same cognitive processes” (Willems et al. 2009: 2396).

Similar to the Willems et al. study, Postle et al. (2008) found effector-specific activity in premotor cortex only when participants viewed actions performed with hand, arm or foot. By contrast, when they silently read the corresponding verbs, there was only activation in premotor cortices. Importantly, premotor leg, arm and hand areas responded to *all* action-verbs in the same way, i. e. there was no somatotopical reaction. In addition, several of these premotor areas also responded to nouns and even non-words. These results constitute strong evidence against prediction (i) i. e. that understanding action verbs and imagining performing those actions rely on the same, or at least overlapping, neural tissues. Summarizing, one gets the following correlations:

- Primary motor cortex is active during motor imagery; during processing of action verbs this cortex is not active, provided no corresponding instructions are given.
- Premotor cortex areas are active during comprehension of action verbs; however, there is no overlap with areas in this cortex that are active during explicit imagery. In addition, there need be no effector-specific activity.

According to Bedny and Caramazza (2011: 87), results like the above raise the important question of whether such activity in left premotor areas is specific to action verb comprehension or whether this activity rather reflects a more general contribution of premotor cortex to language. Evidence for such a more general contribution comes from several studies. Graziano (2006) showed that activity in premotor areas is more sensitive to the behavioral context and possible goals and results brought about by an action.<sup>2</sup> Schluter et al. (1998) found that premotor cortex is involved in higher-order aspects of movement like sequencing and movement selection. Similarly, this cortex is involved in planning and predicting actions and sequentially structured events (Schubotz and von Cramon 2004). When taken together, one gets that the premotor cortex shares features with adjacent prefrontal cortex (Miller and Cohen 2001).

Evidence against prediction (ii) comes from studies involving the middle temporal gyrus (MTG).<sup>3</sup> There is more activity in MTG when participants generate action verbs than when they generate color names for visually presented nouns. MTG is more active when action verbs are processed compared to the processing of nouns for concrete objects and color adjectives. Furthermore, MTG response is equally high with action verbs like *run* and mental state verbs like *think* and it is equally low for nouns denoting animals like tigers which are rich in motion features and nouns like *rock* which are low in motion features. In addition, MTG responds more to verbs like *give* compared to verbs like *run*. This area responds to action verbs in the absence of a sentence context. Representations are neither visual nor motion related and regions in MTG that are activated during processing of action verbs do not overlap with visual-motion regions. Bedny and Caramazza (2011: 91) conclude that “these results argue that the MTG stores modality-independent representations that encode conceptual rather than perceptual properties. ... Together, these results suggest that the MTG represents conceptual information about events or meaning-relevant grammatical information about verbs.”

A key question with respect to prediction (iii) is: Do effector-specific activations show that they are used by speakers to *semantically* analyze the word or the words in a sentence? As first noted in Postle et al. (2008), this need not be the case. The motor activation can be an epiphenomenon of processing the word or the constituents in the sentence. The speaker semantically analyzes the expressions and simultaneously or subsequently (s)he mentally imagines executing a corresponding action or event. As

<sup>2</sup> This example as well as the following ones are taken from Bedny and Caramazza (2011).

<sup>3</sup> For details on the following, see the discussion in Bedny and Caramazza (2011) as well as the references cited therein.



noted by Bedny and Caramazza (2011: 83), language-perception interactions need not result because action-verb meanings are represented but rather because verb meaning representations prime visual motion representations during contemporaneous linguistic and perceptual tasks.<sup>4</sup>

## 2 Action, events and the dynamic structure of action verbs

When viewed from a linguistic, in particular semantic, viewpoint, a general weakness of most studies involving action verbs consists in the restriction to test isolated verb forms, in general infinitive forms like *kick* or *throw*.<sup>5</sup> However, what type of action or event is denoted by an expression, say a sentence, in which an action verb occurs, not only depends on the verb but also on its arguments and their semantic (or referential) properties. Consider, for instance, the German examples in (1).

- (1) a. Hans lief (stundenlang im Park herum).  
b. Hans lief zum Bahnhof.  
c. Hans lief durch den Park.  
d. Hans lief zu Hochform auf.

Example (1a) is an activity expression admitting of modification with a *for*- but not with an *in*-adverbial. It describes an action as unbounded in the sense that no particular goal (say a destination to be reached) is specified.<sup>6</sup> By contrast, example (1b) describes a running that has an explicit goal: the station. The action is therefore bounded by this destination. Linguistically, this is reflected by the admissibility of modification with *in*-adverbials but not of that with *for*-adverbials. Example (1c) can be taken to either describe an unbounded or a bounded event. In the first case it corresponds to (1a) (*Hans ran across the park*), whereas in the second case it corresponds to the English translation *Hans crossed the park*. The last example differs from the preceding ones. Here *laufen*

<sup>4</sup> As noted by Willems et al. (2009: 2398), another reason why there is effector-specific activity in motor areas can be due to the fact that participants in those studies were not prevented from forming mental images. Furthermore, Postle et al. (2008) note that the positive results can be artifacts of differences in imageability between critical and control stimuli. For example, in the Hauk et al. (2004) study, action verbs were compared to hash-marks as lower-level control. As a result, effector-specific activity could have been triggered by increased imagery to concrete action language as compared with more abstract language (see also Willems et al. 2009: 2398).

<sup>5</sup> This limitation becomes even more apparent in languages like Dutch or German where the infinitive form is in general distinct from tensed forms, whereas in English the infinitive coincides with the present tense form.

<sup>6</sup> This does not mean that Hans didn't have a particular destination in mind; for example, the university which he was running to.



ecute the two actions described by the sentences in (2). Similarly, throwing a Frisbee or a baseball requires different grips and different arm motions. These examples show that the sortal information provided by the direct object is, at least in general, important to resolve the underspecification with respect to the exact motor program to be executed. To make the fact of different nuclei structures determined by the same verb clearer, let us consider another set of examples involving the verb *kick*.

- (3) a. John kicked Bill.  
b. John kicked Bill several times.  
c. John kicked the ball into the goal.  
d. John kicked the bucket.

Example (3a) can be used to describe a single (atomic) kicking, the corresponding nucleus structure of which consists of a Cul (without a CS, see Moens and Steedman 1988 and Naumann 2001 for details):  $NS_{Cul}$ . A sequence of such atomic kickings is described by (3b):  $NS_{Cul*}$ . The nucleus structure is complex because it consists of a sequence of nuclei structures having a Cul only. Sentence (3c) describes an event in which the kicking of the ball causes the latter's location to change: before the kicking it was not in the goal whereas it is in the goal as an effect of the kicking. In this case, two nuclei structures are related by a causal relation. The first nucleus structure consists of a Cul describing the kicking proper and the second is a nucleus structure consisting of a DP, a Cul and a CS describing the movement of the ball into the goal:  $NS_1$  CAUSE  $NS_2$ . For (3d), the situation is different. In this sentence, *kick* is not used in its literal sense but it is used idiomatically. Since *kick the bucket* means *die*, the nucleus structure consists of a Cul together with a CS (*be dead*).

Reconsidering the examples in (3), one gets: after processing *John kicked*, which is common to all four sentences, a comprehender cannot (yet) know which of the four nuclei structures is described by the sentence. However, using linguistic knowledge/experience (e. g. frequency information) as well as world knowledge (what type of nucleus structure occurs most often in the context of a kicking), (s)he has a particular expectation about which nucleus structure is most likely be described. For example, the literal (non-idiomatic) uses are in general more expected than the idiomatic sense in (3d).<sup>9</sup> For the literal uses, a possible ordering can be  $NS_{Cul} < NS_1$  CAUSE  $NS_2 < NS_{Cul*}$ , i. e. single kickings are most expected, followed by kickings that are used to obtain a

<sup>9</sup> However, in a context in which it is clear that John is going to die, (3d) can be the most expected continuation.

particular effect and sequences of atomic kickings are least expected.<sup>10</sup> In a particular context, this default ordering has to be changed. For example, upon listening to ... *the ball into the goal* after processing *John kicked ...* a comprehender comes to know that the kicking had a destination and that therefore this sentence isn't used to describe an action of the most expected nucleus structure (Cul) but of type NS<sub>1</sub> CAUSE NS<sub>2</sub>. As a consequence, a less expected nucleus structure has to be chosen.

### 3 Interpreting action verbs in the brain

In our account, understanding the meaning of an action verb is in part determined by knowledge of (i) the set of possible nuclei structures which describe possible temporal-causal evolutions of actions and events denoted by the verb and (ii) the default ranking among the elements of this set. This information about the meaning of a verb is stored in MTG.

This knowledge is only necessary for grasping the (complete) meaning of such a verb because verbs with identical sets of nuclei structures and default ranking would have the same meaning.<sup>11</sup> However, they differ with respect to implicit simulations in premotor cortex in the sense of Willems et al. (2009). Implicit simulations are pre-enactments of potential future experiences, the principal function of which is the ability to make predictions about how exactly an event will evolve and what its possible consequences are. For example, a word like *grasp* can serve as a cue to activate neural circuits involved in partial preparation of an action of grasping something. As noted by the authors: "This schematic, unconscious, prospective activation of effector-specific regions in premotor cortex presumably facilitates further action planning if subsequent cues call for *grasping* to be executed or to be imagined explicitly" (Willems et al. 2009: 2388).<sup>12</sup>

Linguistically, the ranked set of nuclei structures corresponds to the level of verbs in the lexicon. Conceptually, it can be taken as a symbolic, amodal representation of the

<sup>10</sup> Again, it must be stressed that this ordering is to be determined empirically and that it is in general – at least in part – context dependent. For example, in case of a penalty kick during a football match, NS<sub>1</sub> CAUSE NS<sub>2</sub> is likely to be most expected.

<sup>11</sup> But see below for a refinement of this thesis.

<sup>12</sup> By contrast, explicit imagery is covert enactment of an action. Like overt motor execution, motor imagery may entail the generation of an action plan (inverse model) as well as a prediction of the action's sensory consequences (Willems et al. 2009: 2388). Its principle function is either reflective (i. e. covert reenactment of prior actions) or prospective (e. g. an athlete usually imagines the concrete motor program before starting his performance).

concept expressed by the verb that is independent of sensory and motor simulations. By contrast, implicit simulations correspond to projections of the verb like VP or sentences. To be precise, implicit simulations are triggered when a comprehender has enough information to determine a specific way or manner in which the action is executed. As shown in the previous section, this is in general the case if (s)he knows which object undergoes the change brought about by the action. Thus, implicit simulation corresponds to the choice of an appropriate activity, modulo the direct object of the verb.

When taken together, the meaning of a verb consists of two dimensions: a symbolic, amodal dimension and different ways in which these representations can be grounded to specific activities that are undertaken in a particular situation.

Dimension	Level of Abstraction	Reference	Neural Correlate	Function	Linguistic Level
conceptual	symbolic and amodal	ranked set of nuclei structures	MTG	determination of possible evolutions in terms of a temporal-causal structure	(isolated) verb in the lexicon
implicit simulation	grounded	instantiated nuclei structures	regions in premotor cortex	prediction and planning (preenactment of actions)	projections of the verb (VP and S)

At the conceptual dimension actions and events are taken as types (or schemes), whereas at the second dimension these types are instantiated in a particular situation in space and time, yielding an action or event token. This differentiation has the advantage of computational economy since it leads to a reduction on the requirement on storage. Different nuclei structures can be instantiated (or grounded) to various situations belonging to different action types. One has a small number of abstract, symbolic and amodal temporal-causal structures (nuclei structures) that can be instantiated in an indefinite number of concrete situations in space and time. In particular, a nucleus structure of a particular type, say the one depicted in Figure 1 consisting of a DP Cul CS, can be used for (i) different action verbs and (ii) different instantiations of the same type of action. An example for (i) are verbs like *eat* and *run*. Both *eat an apple* and *run to the station* are of type DP Cul CS. They differ with respect to (i) the place in the default ordering and (ii) the types of possible activities that can instantiate this structure. Whereas this nucleus structure is the most expected one for *eat*, this does not hold for *run*, which basically describes unbounded actions with no particular goal or destination. For *eat*, appropriate activities include putting food into the mouth using the hands, a

fork or a spoon or, in the case of an animal, the lips and the tongue. By contrast, for running events appropriate activities are fast movements typically involving the legs.

If a verb is encountered, the set of possible nuclei structures in middle temporal gyrus is activated. In the absence of further information, a comprehender assumes that an event corresponding to the most expected nucleus structure (or the most expected nuclei structures) is (are) described. Accessing verb meanings therefore involves accessing the corresponding nuclei structures. The more complex a nucleus structure, the longer the time to access and/or activate this structure. Thus, there is a cost in processing time that depends on the complexity of the nucleus structure. For example, the most expected nucleus structure for an activity verb like *run* is of type DP. By contrast, for a verb like *give*, which expresses a causal relation involving two different nuclei structures, the most expected nucleus structure is more complex.<sup>13</sup>

The activation of the ranked set of nuclei structures *does involve no immediate activation* of premotor or primary motor areas since no particular implicit or explicit simulation can yet be determined because the choice depends on the argument denoting the object undergoing the change as well on the actor executing the action.<sup>14</sup> Rather, premotor areas related to implicit stimulations are activated only after the nuclei structures are instantiated. As noted above, this is the case for projections of the verb, in particular the VP and the sentence level.

### 3.1 Empirical evidence for our approach

From what has been said so far, the following predictions can be derived from our approach:

- There is only weak activation of primary and premotor areas upon processing of the verb. Activation of the motor system is possible only if the underspecification inherent in a nucleus structure has been removed. This is in general possible only if the type of the object undergoing the change is known.

---

<sup>13</sup> NS<sub>1</sub> : DP (action undertaken by the actor); NS<sub>2</sub> : Cul CS (the recipient gets the theme).

<sup>14</sup> Though this does not exclude the possibility that a comprehender activates a particular simulation intentionally or by convention. For example, a football player or a football fan might usually immediately engage in triggering simulations of a player kicking a football upon hearing or reading the verb *kick*. But such simulations are independent of understanding the meaning of the verb or the sentence in which it occurs. Rather, the meaning of the verb primes particular sorts of motor programs that can be used in executing the action or event type.

- Sentences with an idiomatic sense elicit stronger activation in MTG because a less expected nucleus structure must be chosen. This reordering triggers a higher processing load reflected by a stronger activation in MTG.
- Complex nuclei structures trigger stronger activation because e. g. different types of nuclei structures must be related to each other (e. g. in a causal relation). The general rule is: the more complex a nucleus structure, the stronger the activation.
- Implicit simulation depends on the expertise of the comprehender. For example, both experts (players and fans) and laymen understand sentences about hockey matches. However, players and fans are better able to implicitly simulate actions undertaken during a game. Thus, one expects the same activation in MTG but differences with respect to premotor activity.

Evidence for the truth of the first two predictions comes from an fMRI study by Boulenger et al. (2008). They examined how literal versus idiomatic sentences with action verbs referring either to the leg (*kick*) or the arm (*grasp*) are processed in the brain.

- (4) a. He kicked the ball.  
b. He kicked the bucket.
- (5) a. He grasped the needle.  
b. He grasped the idea.

Brain activity was measured at the onset of the critical word in the sentence (*He grasped the IDEA*) which disambiguated between a literal and an idiomatic reading (early analysis window) and three seconds after its end (late analysis window). They found that (i) a common network of cortical activity was triggered for both conditions in both analysis windows, with the idioms eliciting overall more distributed activity; (ii) primary and premotor cortices were activated both for idioms and non-idioms; (iii) activation of (frontocentral) primary and premotor areas was relatively weak both at action verb onset (and therefore upon processing the action verb) and at the onset of the critical word. However, it was strong after the offset of the critical word both for literal and idiomatic readings; (iv) sentences with literal meanings failed to elicit stronger activation than sentences with an idiomatic reading in any brain area; (v) in the late analysis, window cortical activity was greater in MTG and the cerebellum.<sup>15</sup>

In the present context findings (iii) and (v) are the most important ones. Finding (iii) shows that there is no instant spreading of activation to primary or premotor cortex

---

<sup>15</sup> Furthermore, there was stronger activation of idioms in inferior frontal gyrus in both windows.

during action verb processing. Rather, this activation is delayed until after the direct object has been processed. This is in contrast to the results for processing isolated action verbs. Finding (v) can be taken as providing evidence for our claim that in case a verb is used in an idiomatic sense the default ordering on the set of nuclei structures must be changed (i. e. there is a reordering of the elements of this set), resulting in a higher processing load, reflected in the higher activity in MTG.<sup>16</sup>

Evidence for the third prediction comes from two studies by Shetreet et al. (2007) and Van Dam and colleagues (2010), respectively. Shetreet and colleagues found that MTG responds more strongly to sentences with verbs that have more arguments, even when the sentences have the same overall length. For example, processing *John gave Mary the book* (three arguments) triggers stronger activity in MTG than the sentence *John ran to the station* (two arguments). In our approach, a verb like *give* is related to a complex nucleus structure consisting of two substructures that are linked by a causal relation. The first nucleus structure describes the action undertaken by the giver (actor) whereas the second nucleus structure describes the event of the recipient receiving (and thereby coming to possess) the theme, i. e. the object given. Van Dam and colleagues (2010) found that the processing of action verbs like *wipe* that denote events describing a particular way of moving part of the body triggers stronger inferior parietal activity than verbs like *clean* for which no such manner is determined. This finding can be explained as follows. Levin and Rappaport-Hovav (to appear) distinguish between verbs of manner and verbs of result. Manner verbs specify a particular way in which an action is executed. For example, *wipe* and *brush* determine a particular way of cleaning an object without imposing the constraint that the result be attained at the end of the event. By contrast, result verbs specify a particular end state of the action. For example, *clean* requires the object undergoing the change, say a table, to be clean as a result of the cleaning activity undertaken by the actor. However, no specific type of activity (or manner) by which this end state is achieved is determined by the verb. In our approach, manner verbs like *wipe* have a most expected nucleus structure of type DP, i. e. they are basically activity verbs that are usually used to describe unbounded events which need not bring about a particular result (similar to a verb like *run*). By contrast, a result verb like *clean* has a most expected nucleus structure of type DP Cul CS. However, for *clean* only the culmination is explicitly determined (the object has to be clean) but no particular activity.

---

<sup>16</sup> For details on how such orderings can be changed, see Naumann (2011, 2013, 2014).



In our approach, this means that the interpretation of a result verb is already determined by the ranked set of nuclei structures since the only constraint is the one imposed on the end state (*be clean*), which is already specified at the lexical level and which therefore is independent of the object undergoing the change. As a consequence, being able to implicitly simulate how the action can be executed is not part of the meaning of the verb. From this it does not follow that a comprehender does not engage in an implicit simulation (and, additionally, in explicit imagery). But in this case, (s)he plans or imagines an execution that can be described by another verb, say *wipe* as in *wipe the table clean*.

Further evidence for our analysis comes from a study by McKoon and Macfarland (2000). They showed that there are no differences in processing time between transitive and intransitive uses of so-called externally caused event verbs like *break* and *awake*.

- (6) a. The fire alarm awoke the residents.
- b. The residents awoke.

By contrast, for internally caused event verbs like *bloom* and *wilt*, processing times are significantly shorter than those for externally caused event verbs.

- (7) a. The bright sun wilted the roses.
- b. The roses wilted.

Again, there are no differences between the transitive and the intransitive form. These results therefore show that the processing time depends on the type of the (preferred or most expected) nucleus structure. Furthermore, these examples show that the cost in processing time is *independent* of the exact syntactic realization (transitive vs. intransitive). Rather, it only depends on the corresponding types of nuclei structures.

Similar results were obtained by Gennari and Poeppel (2003). They showed that processing non-stative verbs like *vanish* and *solve* takes longer than processing stative verbs like *love* and *exist* (about 25 ms), even if the argument structures are identical (e. g. *exist* and *vanish*).

Evidence for the fourth prediction comes from a study by Beilock and colleagues (2008). They let hockey players, hockey fans and hockey novices listen to sentences about hockey-related actions. They found that both for hockey players and hockey fans there was an increased activity in dorsal premotor cortex compared to the activity in this area for hockey novices. Furthermore, this stronger activity was influenced by experience with hockey games but not necessarily by motor experience directly related to playing the sport. For example, dorsal activity was the same for hockey players and

hockey fans. In addition, only for hockey novices the primary sensory-motor cortices were active and increased primary sensory-motor activity correlated negatively with action sentence comprehension.

The above empirical results can be taken as evidence for the following two hypotheses: (i) result verbs are not directly related to particular implicit simulations or motor programs and (ii) for result verbs, grounding of a corresponding nucleus structure is, at least in part, independent of their types. By contrast, manner verbs require (i) activation of the related ranked set of nuclei structures in MTG and (ii) an implicit simulation in premotor cortex (in order to distinguish say *brush* from *wipe*). These hypotheses raise the following questions: (i) what is the exact relation between the ranked set of nuclei structures and implicit simulations? And (ii) where is this relation stored in the brain (i. e. what is the neuronal correlate of this relation)? One answer to the first question is that the ranked set of nuclei structures for a verb in MTG primes certain implicit simulations in premotor cortex. To be more precise: both manner and result verbs are related to a set of appropriate activities. Information about these activities is stored in regions of premotor cortex. For manner verbs this set is more restricted than that for result verbs. Furthermore, and more importantly, the set of activities for manner verbs is ranked in the sense that not all elements in this set are equally expected. By contrast, for result verbs there is no ranking on this set. For example, for *wipe*, one has *rub with a cloth or one's hand* and for *brush*, *rub with a brush*. The set of appropriate activities for *clean* comprises those for *wipe* and *brush* (and those for other manner verbs which denote actions for cleaning something). A possible answer to the second question goes along Hebbian lines. Neuronal correlation is mapped onto connection strength. If an action verb frequently co-occurs with body movements that are executions of an action of the type denoted by the verb, this strengthens the connection between regions in MTG and regions in premotor cortex. There remain, of course, a number of open empirical questions, for example: *Where in the brain is the 'meaning assembly' between a verb and its arguments located, i. e. what is the exact relation between verbal (dynamic) and non-verbal (static) meanings?* and *How is the ranked set of nuclei structures acquired in the brain during language learning?*

Furthermore, the above results also show that the various dimensions are not independent of each other. When taken together, the findings of the empirical studies used in this article suggest the following relation. Both implicit and explicit simulations are functionally or causally dependent on the conceptual domain consisting of the ranked set of nuclei structures in MTG. Empirical evidence supporting this claim is: (i) MTG

responds to verbs in isolation for sentences with transitive verbs and (ii) the motor system is activated only after the direct object has been processed. Thus, when processing a verb, regions in MTG are activated but no effector-specific activity in the motor system is (yet) triggered. Consequently, MTG is activated *prior* to the motor system. By itself, this temporal relation does not show that there is a functional or causal relation between those dimensions. However, both types of activity are directly related to processing the verb and therefore to understanding its meaning, which makes it likely that some functional relation is involved. Of course, this claim needs to be confirmed by further empirical investigations.

Finally, an important empirical question is this: is the ability to trigger implicit simulations in premotor cortex constitutive of grasping the meaning of (or to have the concept corresponding to) an action verb? In our approach the answer is negative for the following reason. The two dimensions in the meaning of an action verb correspond to different functions language and cognition have. The conceptual dimension is related to naming and recognizing objects of the given type. Evidence for this comes from studies of patients suffering from apraxia as well as from the discussion of the results about hockey obtained by Beilock and colleagues. This dimension is non-goal oriented in the sense that no implicit preenactment of a possible execution is involved.<sup>17</sup> The second dimension, i. e. implicit simulation, is related to reflecting, predicting and planning an action of the given type by selecting appropriate activities and inferring future consequences of executing this action. Possible questions are: *How can the goal be reached?*, *What is an appropriate activity to reach the goal or to execute the action?* and *What are possible consequences of executing the action?* This dimension therefore is goal-oriented at a theoretical level (i. e. it does *not* involve the ability to execute a motor program). This ability is a necessary condition for being able to attain a goal or result by executing an action of the given type. For example, in the case of eating one can use the hands or, alternatively, a fork and a knife. By contrast, explicit imagery corresponds to the ability of actually executing a motor program to attain the goal.<sup>18</sup> The inability to have implicit simulations impairs a speaker for this particular function. This is the case for patients

<sup>17</sup> Though it may involve naming the goal of a possible execution, e. g. making an object clean for the verb *clean* since involving a goal (Cul) is part of the most expected nucleus structure of this verb.

<sup>18</sup> Additional evidence for this analysis comes from studies of apraxia, i. e. the inability to perform particular activities as a result of brain damage. People suffering from this inability are impaired for using objects of a particular kind, say a hammer, though they are unimpaired for (i) naming those objects and (ii) recognizing pantomimes associated with uses of those objects. Thus, integrity of motor processes is not necessary in order for object naming and action recognition to be in the normal range; see Mahon and Caramazza (2008) for details.

suffering from apraxia. However, the Beilock et al. study shows that that the ability to have implicit simulations comes in degrees. Hockey novices do have activity in the motor system, though it is less strong than the activity triggered in hockey players and hockey fans.<sup>19</sup>

### 3.2 Comparison to theories of grounded cognition

Our approach differs from theories of grounded cognition in the following respects. First, ‘automatic activation’ does not mean that the motor system is immediately activated when a verb is processed in the brain, i. e. that linguistically processed input immediately results in activation of the motor and sensory systems. Rather, what is immediately activated is the ranked set of nuclei structures. Groundedness is not an attribute of the verb proper but rather a property of its projections like VP or S. The reason for this is that the conceptual level stored in MTG is impoverished in the sense that verbs which have the same ranked set of nuclei structures cannot be distinguished. This distinction is only made if a nucleus structure is instantiated. The neural correlate of this instantiation is an implicit simulation in premotor cortex.

It may seem that this view is contradicted by the results of Hauk et al. (2004) and others showing that the motor system is activated rather quickly. Recall that Hauk et al. found that when presented with the word *kick* the ‘leg’ region of the motor system is activated within a time span of about 200 ms. Yet those results do not provide counterevidence to our claims. First, those results were obtained for *isolated* verbs and not for sentences in which these verbs occur as a constituent and this fact was known to the participants. When taken in isolation, a verb like *kick* is interpreted by uniquely describing a nucleus structure consisting only of a Cul because a comprehender already knows that no further information, say about a goal of the kicking, is added, which may make it necessary to change the nucleus structure to one of type Cul CAUSE NS<sub>2</sub>.

A second difference is that in our approach, following Willems et al. (2009), a distinction is made between implicit simulations and explicit imagery. Third, explicit imagery is an epiphenomenon of processing (and thereby understanding the meaning) of the verb. As pointed out in the previous section, a verb (or its corresponding ranked set of nuclei structures) primes certain ways in which an action denoted by the verb is executed. As a result, an implicit simulation can be triggered. This way of undertaking the

---

<sup>19</sup> However, it remains an open empirical question of whether this activity is related to *both* implicit simulation and explicit imagery or to only one of those activities in the motor system.

action may subsequently result in explicit imagery of the corresponding action. Fourth, and most importantly, a distinction between a symbolic and amodal dimension and a grounded dimension is made in the definition of the meaning of an action verb.

Summarizing, one can say that theories of grounded cognition only capture one particular dimension of a verb's meaning, i. e. that related to the motor system. However, they usually do not distinguish between implicit simulations and explicit imagery. In addition, if it is true that both of these activities in the motor system are functionally and causally dependent on a conceptual dimension, they fail to give a satisfactory account of how meanings are represented and accessed in the human brain. This failure is in large part due to the fact that most often only isolated verbs and not larger linguistic contexts, like sentences, in which those verbs occur are considered.

Another way of comparing theories of grounded cognition and ours is the following. Mahon and Caramazza (2008) distinguish four possibilities of how the motor system can be related to a conceptual dimension.

1. Processing the verb directly activates the motor system, with no intervening access to abstract conceptual content.
2. Processing the verb directly activates the motor system and in parallel activates abstract conceptual content.
3. Processing the verb directly activates the motor system and then subsequently activates an abstract conceptual representation.
4. Processing the verb directly activates an abstract conceptual representation and then activates the motor system.

Only on the fourth possibility is the conceptual dimension activated *before* the motor system, whereas in the other three possibilities the motor system is either independent of the conceptual dimension (1), works in parallel with it (2) or there is a cascading flow of information from the motor system to the conceptual dimension (3). The first three possibilities underlie the various forms of theories of grounded cognition: The motor system is never activated after the conceptual system (provided the latter is assumed at all). Our approach is characterized by the fourth possibility. First, the ranked set of nuclei structures in MTG is activated and subsequently implicit simulations in specific premotor areas are triggered by a spreading activation.

## 4 Comparison to other approaches

Similar to our approach, the grounding by interaction account proposed in Mahon and Caramazza (2008) distinguishes between an abstract or symbolic level of representation and its instantiation (or grounding) in a particular situation. The symbolic level is conceptual and characterized by various output modalities like being able to name an object or action falling under the given concept or knowing something about the way it is built up or construed. For example, in the case of a hammer this conceptual knowledge possibly involves being able to recount the history of the hammer as an invention, the materials of which the first hammer was made, or what hammers typically weigh (Mahon and Caramazza 2008: 67 f.). This conceptual information can apply to diverse sensory modalities like touch, vision or audition. What is missing from this level is the interaction with the world. Conceptual information is not isolated. Rather, it can be activated by events in the world that are processed by the sensory system. As an effect, the conceptual information gets instantiated in a particular situation. The specific sensory and motor information that is activated may change depending on the situation in which the abstract conceptual information is instantiated (Mahon and Caramazza 2008: 68). However, from this it does not follow that the sensory and motor information is constitutive of the concept. Rather, removing the sensory and motor system would result in impoverished and isolated concepts. Thus, the activation of sensory and motor processes contributes to the ‘full’ representation of the concept.

The approach presented here bears some similarity with constraint-satisfaction-based approaches, like that of Jurafsky (1996) for example. According to such accounts, the processing of a sentence first involves the activation of several possible interpretations. These interpretations are ranked according to a probability measure that is based, among other factors, on the likelihood of a particular word being used in a particular context or the likelihood of a verb to be used with a particular meaning. For example, the noun *nail* refers either to a body part (fingernail, toenail) or a metal fastener. Processing this word therefore involves activation of brain areas related to both meanings of the word.<sup>20</sup> This set of possible interpretations is narrowed down when further information in the sentence is processed: *The nail he used to put up the picture.*

---

<sup>20</sup> According to Zwaan and Kaschak (2008), from which this example is taken, the processing involves the activation of traces or mental simulations that are relevant to both senses of the word, in accordance with the embodiment thesis.

## **5 Conclusion**

In this article we presented a theory of action verbs that combines an abstract, modality-independent component with a modality-specific component located in regions of premotor cortex. Semantically, this analysis is based on the observation that a verb like *kick* can be used to express different types of actions (*kick/kick the ball/kick the ball into the goal*) that differ with respect to parameters like telic/atelic, result/no\_result or atomic/iteration. The conceptual information about events are the different types of nuclei structures and the meaning-relevant information about a verb is the ranked set of such structures that represents the conceptual dimension of its meaning. This information is amodal and concerns the temporal-causal structure of an action or event. It is stored in MTG, which has been shown to respond to the processing of verbs as opposed to nouns and adjectives.

This temporal-causal structure is underspecified with respect to the exact way or manner (motor program) an action of a particular type is executed because this way depends on the object undergoing the change. After combining with the direct object of the verb, this structure is grounded or instantiated by a spreading activation to premotor cortex leading to an implicit simulation which makes it possible to derive additional conclusions about this structure.

## **6 References**

- Barsalou, L. W. (1999). Perceptual symbol systems, *Behavioral and Brain Sciences*, 22, 577–660.
- Beilock, S. L. et al. (2008). Sports experience changes the neural processing of action language, *Proceedings National Academy Sciences USA*, 105, 13269–13273.
- Boulenger, V., O. Hauk and F. Pulvermüller (2009). Grasping ideas with the motor system: semantic somatotopy in idiom comprehension, *Cerebral Cortex*, 19, 1905–1914.
- Buccino, G. L. Riggio, G. Melli, F. Binkofski, V. Gallese and G. Rizzolatti (2005). Listening to action related sentences modulates the activity of the motor system; a combined TMS and behavioral study, *Cognitive Brain Research*, 24, 355–363.
- Gallese, V. and G. Lakoff (2005). The brain's concepts: the role of the sensory-motor system in conceptual knowledge, *Cognitive Neuropsychology*, 22, 455–479.
- Gennari, S. and D. Poeppel 2003. Processing correlates of lexical semantic complexity, *Cognition*, 89, B27–B41.

- Graziano, M. 2006. The organization of behavioural representation in motor cortex, *Annual Review of Neuroscience*, 29, 105–134.
- Hauk, O., L. Johnsrude and F. Pulvermüller (2004). Somatotopic representation of action words in human motor and premotor cortex, *Neuroscience*, 41, 301–307.
- Jurafsky, D. 1996. A probabilistic model of lexical and syntactic access and disambiguation, *Cognitive Science*, 20, 137–194.
- Levin, B. and M. Rappaport Hovav (to appear). Lexicalized meaning and manner/result complementarity, In: B. Arsenijević, B. Gehrke, and R. Marín, (Eds.), *Subatomic Semantics of Event Predicates*, Springer, Dordrecht.
- Mahon, B. Z. and A. Caramazza (2008). A critical look at the embodied cognition hypothesis and a new proposal for grounding conceptual content, *Physiology – Paris*, 102, 59–70.
- McKoon, G. and T. Macfarland 2000. Externally and internally caused change of state verbs, *Language*, 76, 833–858.
- Miller, E. K. and J. D. Cohen 2001. An integrative theory of prefrontal cortex function, *Annual Review of Neuroscience*, 24, 167–202.
- Moens, M. and M. Steedman (1988). Temporal ontology and temporal reference, *Computational Linguistics*, 14: 2, 15–28.
- Naumann, R. (2001). Aspects of changes: a dynamic event semantics. *Semantics* 18: 27–81.
- Naumann R. (2011). Relating ERP-effects to theories of belief update and combining systems. In: M. Aloni et al. (Eds.), *Proc. 18th Amsterdam Colloquium*, LNCS, Springer, Berlin.
- Naumann, R. (2013). Outline of a dynamic theory of frames. In: G. Bezhanishvili, S. Löbner, V. Marra, and F. Richter (Eds.), *Proceedings of the 9th International Tbilisi Symposium on Language, Logic and Computation*, Volume 7758 of Lecture Notes in Computer Science, pp. 115–137. Springer Berlin Heidelberg.
- Naumann, R. (2014). *A dynamic update model of sentence processing*, ms, University of Düsseldorf.
- Postle, N. et al. 2008. Action word meaning representations in cytoarchitectonically defined primary and premotor cortex, *Neuroimage*, 43, 634–644.
- Pulvermüller, F. (1999). Words in the brain’s language, *Behavioral Brain Science*, 22, 253–336.
- Pulvermüller, F. (2005). Brain mechanisms linking language and action, *Nature Reviews Neuroscience*, 6, 576–582.



- Schluter N. D. et al. 1998. Temporal interference in human lateral premotor cortex suggests dominance for the selection of movements. A study using transcranial magnetic stimulation, *Brain*, 121, 785–799.
- Schubotz, R. I. and D. Y. von Cramon 2004. Sequences of abstract neurobiological stimuli share ventral premotor cortex with action observation and imagery, *Neuroscience*, 24, 5467–5474.
- Shetreet, E. et al. (2007). Cortical representation of verb processing in sentence comprehension: number of complements, subcategorization and thematic frames, *Cerebral Cortex*, 17, 1958–1969.
- Van Dam, W. O. et al. (2010). How specifically are action verbs represented in the neural motor system: an fMRI study, *Neuroimage*, 53, 1318–1325.
- Willems, R. M. et al. 2009. Neural dissociations between action verb understanding and motor imagery, *Cognitive Neuroscience*, 22, 2387–2400.
- Zwaan, R. and M. Kaschak (2008). Language in the brain, body, and world, In: M. Robben and M. Aydede (Eds.) *Cambridge handbook of situated cognition*, Cambridge: CUP, 368–381.



SANDER LESTRADE

## The place of Place (according to spatial case)

Sander Lestrade  
Radboud University Nijmegen  
Centre for Language Studies

s.lestrade@let.ru.nl

### Abstract

This paper addresses the question whether we should analyze Place, expressing the absence of a change of location, on a par with mode expressions specifying the type of such a change, i. e. Source and Goal. By cross-linguistic study of spatial case systems, various options of analysis are considered and illustrated. It is concluded that languages may differ in their spatial expression of Place, suggesting a non-uniform semantics and, possibly, conceptualization. Also, it is proposed to view these various analyses as diachronic variants.

Keywords: spatial language, Place, mode/directionality, morphological decomposition

## 1 Introduction<sup>1</sup>

If a moving entity is to be localized, it generally does not suffice to merely provide a location.<sup>2</sup> Instead, it needs to be made clear at which interval of the motion event this *locatum* can be found there. For this, mode expressions such as *to* and *from* can be used (mode is probably better known as *directionality*, a tradition that is not followed here for reasons explained in Lestrade 2011 and 2012). Mode expressions restrict the location of a locatum to a specific interval of the event only, for example to the end point (*Goal*) or to the starting point (*Source*) of the motion event. In the following example, the locatum *John* is said to be *in the house* at the end point of the walking event only by the mode expression *-to*:

- (1) *John walked into the house.*

The question to be addressed in this paper is whether we should acknowledge *Place*, which would then locate the locatum to the location throughout the whole event, as a third distinction of mode on a par with Source and Goal. That is, should we think of

---

<sup>1</sup> I would like to thank an anonymous reviewer for comments and suggestions that helped to improve this paper.

<sup>2</sup> For original terminology and discussion, see Talmy (1990), Jackendoff (1983), Kracht (2002), Wälchli and Zúñiga (2007), Levinson (2000), and Bateman et al. (2010).

mode as an obligatory dimension, defaulting to Place mode in the absence of motion, or rather as an optional dimension of spatial expressions that is only used if necessary, in combination with motion verbs (only distinguishing Source and Goal)? Before discussing this question in more detail, let us further agree on the terminology: The locations that mode assigns to some point in time are named regions expressed by the *configuration* function, for example ‘in’, ‘under’, and ‘between’. These locations are defined with respect to a reference object called the *ground*. In (1), the configuration is ‘in’ and the house is the ground, therefore the location is the inside of the house; with John being the locatum and the mode being Goal, John is said to be in the house at the end point of the walking event only.

The reason to consider Place as a mode option, something that may seem unnecessary from an English perspective, can be illustrated by the following part of the spatial case paradigm of Hungarian:

- (2) Partial Hungarian case paradigm
- |                  |                |                 |
|------------------|----------------|-----------------|
| <i>házon</i>     | <i>házra</i>   | <i>házára</i>   |
| ‘onto the house’ | ‘on the house’ | ‘off the house’ |
| (superlative)    | (superessive)  | (superrelative) |

Spatial expressions in Hungarian consistently come in three variants, one for Goal, one for Source, and one for Place (a term that necessarily remains without proper definition in this first part of the paper). This three-way distinction suggests that, morphologically at least, Place may be on a par with Goal and Source in some languages. But whereas analyses of mode all agree on accepting Goal and Source, they differ in whether they recognize Place as a distinction of mode too (Kracht 2002, 2008; Lestrade 2010, 2011) or analyze it as the absence of such a distinction instead (e. g., Jackendoff 1983, 1990; Zwarts 1997, 2005; Wunderlich 1991; Schank 1973).

Intuitively, it could be argued both ways indeed. If mode is defined as restricting the scope of the location (of some locatum) to an interval either before or after a change of location, this function does not apply in the absence of such a change. On the other hand, mode could be argued to be an obligatory ingredient of spatial meaning and/or spatial expressions. In this case, the link between the location and the event time is always made, irrespective of whether they concern stative or motion events, and possibly by zero markers for specific modes for reasons of economy. (The use of zero markers is not as obscure a strategy as it may seem, cf. the use of zero markers for what is called *nominative/absolute* case in many languages; de Hoop and Zwarts 2010; Creissels 2010). Whereas Goal and Source temporally restrict a location to the end

or beginning of an event, Place mode in this view expresses that some location holds for the whole event. The two options are illustrated for English in (3) and (4), example (5) is given for contrast with an overt mode expression.

- (3) Place as the absence of mode (mode is optional)
- |             |                   |  |                  |                   |
|-------------|-------------------|--|------------------|-------------------|
| <i>John</i> | <i>is walking</i> |  | <i>in</i>        | <i>the house.</i> |
| locatum     | V                 |  | configuration:in | ground            |
- (4) Place as a distinction of mode (mode is obligatory (and zero marked in English))
- |             |                   |             |                  |                   |
|-------------|-------------------|-------------|------------------|-------------------|
| <i>John</i> | <i>is walking</i> | $\emptyset$ | <i>in</i>        | <i>the house.</i> |
| locatum     | V                 | mode:Place  | configuration:in | ground            |
- (5) Goal mode (for contrast)
- |                |                  |             |                     |                   |
|----------------|------------------|-------------|---------------------|-------------------|
| <i>The cat</i> | <i>is coming</i> | <i>from</i> | <i>under</i>        | <i>the table.</i> |
| locatum        | V                | mode:Source | configuration:under | ground            |

In fact, the choice is more complicated: It could be argued that there are three possibilities when barring Place from the mode domain. First, it could simply be the absence of mode as just illustrated in (3). Second, however, Place could be a generalized configuration. In this case, it generalizes over all possible configurations, i. e. ‘in’, ‘under’, etc., expressing that although there necessarily is some configurational relation between the locatum and the ground in the world out there, its linguistic specification is deemed unnecessary (for example because its completely predictable, as is often the case with typical pairings such as between coffee cups and tables). Thirdly, the function of Place could be to change the named region referred to by the configuration into a predicate that establishes the link between a location and the locatum, for exemplifying changing ‘in the house’ into LOC(LOCATUM, IN THE HOUSE). This predicate may then subsequently be specified temporally by mode expressions if necessary. Under this analysis, Place is just another term for the locative function, a semantic function necessary for a compositional semantics of the spatial expression (cf. a.o. Creary, Gawron, & Nerbonne, 1989; Wunderlich, 1991; Zwarts, 1997; Kracht, 2002; Bateman 2010). The different options are illustrated in the abstract in the following examples:<sup>3</sup>

- (6) Place as the absence of mode:  
 $[_{\text{mode}} \{ \text{Source}, \text{Goal} \} [_{\text{configuration}} \{ \text{‘in’}, \text{‘under’}, \text{etc.} \} ] ]$
- (7) Place as a generalized location:  
 $[_{\text{mode}} \{ \text{Source}, \text{Goal} \} [_{\text{configuration}} \{ \text{Place}, \text{‘in’}, \text{‘under’}, \text{etc.} \} ] ]$

<sup>3</sup> Square brackets (“[]”) show the scope of the functions mentioned in the subscripts; curly brackets (“{}”) list the options a function has.

(8) Place as the locative function:

[<sub>mode</sub> {Source, Goal}] [<sub>locative function</sub> Place [<sub>configuration</sub> {'in', 'under', etc.}]]]

(9) Place as a distinction of mode:

[<sub>mode</sub> {Source, Goal, Place}] [<sub>configuration</sub> {'in', 'under', etc.}]]]

In the next section, these options will be illustrated with concrete cross-linguistic examples. Then also, it will be shown that it is not possible to decide between these options, or rather, that cross-linguistic data suggest that each of these analyses may be true for at least some languages. Accordingly, this paper will argue that although Place may not be a full-fledged distinction in the mode systems of all languages, our analysis of mode should at least leave open the possibility for Place to become one of its distinctions. Importantly for the topic of the present collection of papers, such different morphosyntactic behavior between languages bears on our account of the cognitive representation of spatial meaning: If the spatial systems of languages differ in fundamental ways, we may have to conclude that also our cognitive representation of space is not universal (cf. for example Levinson 1996 and Li and Gleitman 2002).

## 2 Methodology

To illustrate the different analyses above, we will make use of a method called *morphological decomposition*. This method assumes a fair degree of compositionality between spatial expressions and spatial meaning: If some morpheme can be straightforwardly linked to a semantic function, its very use is taken as evidence for the existence of this function. In fact, we have already used this method in our examples above, suggesting that there is something as Source mode in English on the basis of the use of *from*. As the input for our decomposition exercise, we will consider a number of spatial case systems (for a more elaborate discussion of spatial case inventories and the motivation to use them in studies of spatial language, cf. Lestrade 2012). The reasoning goes as follows. If in a system of paradigmatic oppositions the markers of Place are at the same level as the markers of Goal and Source, we may want to conclude that Place semantically is on a par with Goal and Source too. That is, if Place is mutually exclusive with Goal and Source and all three may be added on top of configuration distinctions, we should probably analyze Place, Goal and Source alike as mode options. If, on the other hand, the markers for Goal and Source morphologically include the marker for Place, this suggests that Place is the input of Goal and Source semantically too.

By deconstructing the spatial expressions into their morphological parts in a number of languages, it will be shown that there is some truth in each of the analyses, or, phrased less optimistically, that the evidence from the morphological decomposition of spatial case is not conclusive to decide once and for all which of the options should be considered the right one. But before we get there, it should be noted that there is an important caveat to this procedure. Morphological markers may be developed over and over again within a stable system of oppositions (Kiparsky 2012) and apparent inclusion relations may only be a coincidence. Therefore, evidence from this method should only be generalized if the results are consistent throughout the spatial expressions between or, depending on the range of the generalization, within languages. Secondly, the interpretation of the results partly depends on whether or not one accepts zero markers. Whereas zero expressions are wholeheartedly accepted by many linguists, they are at the same time forcefully rejected by many others. In general, however, their rejection causes increased complexity or idiosyncrasy at some other point of the analysis. The choice thus seems to be between accepting a zero for a more general semantics vs. a WYSIWYG account at the cost of generality. For present purposes, zero markers are only modestly allowed and avoided whenever possible.

### **3 Analyses of Place**

#### **3.1 Place as the absence of mode**

If Place is really the absence of mode, as again schematically represented in (10), it should not appear.<sup>4</sup> For if Place overtly marked the absence of Goal and Source, we probably would want to analyze it as a mode distinction itself. That is, more generally, whereas specific levels of a function may be defined negatively with respect to other levels (e. g. *that* as ‘not this’), we probably do not expect a linguistic expression to express the absence of an (abstract) function (e. g. *the* in terms of the absence of deixis).

(10) Place as the absence of mode:

[<sub>mode</sub> {Source, Goal} [<sub>configuration</sub> {‘in’, ‘under’, etc.} ] ]

In some languages, the absence of a change of location is indeed covertly expressed only, and therefore, on the basis of these languages, Place could be said not to exist (“to be the absence of mode”). Rather than using an exotic spatial case paradigm, English prepositions may illustrate this type of mode system:

<sup>4</sup> The non-existence of a Place marker crucially sets this analysis apart from the others.

(11) *The mouse ran...*

- a. ... *across the floor.*
- b. ... **from** *under the table.*
- c. ... **into** *its hole.*

Whereas Goal and Source are overtly marked in (11-b,c) as indicated with bold face, there is no additional marking in (11a). The (relevant part of the) English spatial system can thus be represented as follows:

(12) English spatial expressions:

[<sub>mode</sub> {*from, to(/-to)*} [<sub>configuration</sub> {'in', 'under', etc.} ] ]

In this analysis, the absence of Goal and Source is taken to correspond to the absence of the mode function in general.

### 3.2 Place as a generalized configuration

If place is a generalized configuration, it should not occur in combination with more specific configurations, as these should be mutually exclusive: From a functional perspective, it does not make much sense to standardly, that is, not as a restatement but as the normal way of expression, mark something in general and at the same time express it in more detail too (cf. \**a vehicle car*, for an attempt to illustrate with a lexical example). According to this analysis, Place always substitutes more specific configurations. The abstract semantic representation is repeated as (13) for convenience.

(13) Place as a generalized location:

[<sub>mode</sub> {Source, Goal} [<sub>configuration</sub> {Place, 'in', 'under', etc.} ] ]

Although Place in principle may be expressed covertly under this analysis, it could then also be argued to favor the type of analysis to be discussed next. Therefore, we will only consider *overt* instances of generalized configurations in this section.

The locative suffix *-(i)ng* in Tswana (a Niger-Congo language spoken in South Africa) could be analyzed as a generalized configuration. Tswana has a subset of nouns used in spatial function without the addition of the locative case marker. Spatial configurations are specified by means of prepositions that are historically locational nouns (Denis Creissels, p.c.). These constructions, from which the locative case marker is lacking, are used if the configuration needs to be expressed explicitly:



Tswana (Creissels, p.c.)

- (14) *morago ga lebota*  
 behind GEN wall  
 ‘behind the wall’

The locative suffix does not appear on top of such configuration markers but seems to be used in their stead, when a more specific expression is considered superfluous. Consider the following examples.

- (15) Tswana (Creissels, 2006a, 23)
- a. *Monna o dule motse-ng.*  
 man s3:1 leave.PFT 3village-LOC  
 ‘The man left the village.’
- b. *Monna o ile noke-ng.*  
 man s3:1 go.PFT 9river-LOC  
 ‘The man went to the river.’

The configurational interpretation of the locative suffix depends on the type of ground (probably ‘in’ for villages and ‘at’ for rivers); Mode is contributed by the motion verb (Source in (15a) and Goal in (15b)). Note that not all verbs of movement are able to contribute Goal or Source mode (cf. Reshöft and Lestrade 2013 for more elaborate discussion on spatial-meaning dimensions expressed by motion verbs). Verbs that mostly express manner of motion, such as *taboga* ‘run’, *akofa* ‘hurry’, *fofa* ‘fly’, and *feta* ‘pass’, do not contribute mode:

Tswana (Creissels, 2004, 11)

- (16) *Ke tlaa taboga ko tsele-ng*  
 s1s FUT run-FIN DISTANT 9road-LOC  
 ‘I will run on the road’

In sum, in Tswana the locative suffix *-(i)ng* seems to be used to generalize over specific configurations. If more specific configurations are expressed, it is not used. Also, it does not add any mode meaning whatsoever, a function that seems restricted to motion verbs (or applicative markers, cf. Creissels 2004).

### 3.3 Place as the locative function

To tell apart an analysis of Place as the locative function and the previous analysis, its expression should occur between mode expressions and overt configuration expressions:



Very differently from the situation in Tswana, however, the combination of configurational expressions and Place seems very well possible in Malayalam, suggesting that the analysis of Place as a generalized configuration may not be right. The locative marker can be recognized in many configurational expressions, such as *munpil* ‘in front of’ and *pinnil* ‘behind’ (although this is not always possible, cf. *mite* ‘above’, *meel* ‘on’), and also examples of the “complete” structure in (17), using both mode, locative function, and configuration, are easily found, as illustrated for Source in (18):

- (19) *Avan vaatilinre pinn-il ninnə vannu.*  
he door-GEN behind-LOC from come.PAST  
‘He came from behind the door.’

These combinatory possibilities then suggest an analysis in terms of the locative function. Note however that if we analyze the locative marker in Malayalam in terms of the locative function, the linguistic specification of configuration has to be optional, as it would then be lacking from (16a-b). (Again, reduced complexity at one level causes increased complexity at some other place.)

### 3.4 Place as a distinction of mode

Finally, Place could be a full-fledged mode distinction. In this case, we expect it to be mutually exclusive with Source and Goal, all three being expressed on top of configuration expressions:

- (20) [mode {Source, Goal, Place} [configuration {‘in’, ‘under’, etc.} ]]

A pattern that suggests this type of analysis can be observed in Northern Akhvakh. Creissels (2009, 5) shows that the spatial case paradigm of Northern Akhvakh can be decomposed into a configuration and mode marker. As illustrated in Table 1, the spatial paradigm consists of complex markers that combine a configurational and a mode morpheme. For example, the Place morpheme *-e/i* is put on top the configuration *-Ī* ‘under’ to express ‘under’; if the Source marker *-a(je)* is added to this configuration instead, we get ‘from under’.

Crucially, Northern Akhvakh has an independent Place marker on top of the configuration markers that is in complementary distribution with the other mode markers. We can observe similar patterns in the spatial case paradigms of for example Hungarian and Finnish. Since Place patterns with the other mode distinctions in these systems, one could argue that it is a mode distinction too.

	Place	Source	Goal
default configuration	-g-e	-g-a(je)	-g-u(ne)
‘in the vicinity of’	-χar-i	-l̄ir-a(je)	-χar-u(ne)
a. ‘in a relatively narrow space’ b. ‘distributed or diffused localization’	-q̄-e	-q̄-a(je)	-q̄-u(ne)
‘under’	-l̄-i	-l̄-a(je)	-l̄-u(ne)
a. ‘in a filled dense space’ b. ‘on a non-horizontal surface’	-l̄-i	-l̄-a(je)	-l̄-u(ne)

Table 1: Northern Akhvakh spatial case paradigm

Slightly more complex evidence can be derived by considering the case forms of the spatial adpositions of these languages. Hungarian has ten spatial cases in total, distinguishing three mode options for three very general configuration distinctions (approximated by ‘in’, ‘at’, and ‘on’; only the latter of which was illustrated in Section 1) and having an additional terminative case that does not combine with these three configurations. In addition, Hungarian can make use of adpositions to express spatial meaning. The stems of these spatial postpositions express specific configuration distinctions, whereas their case forms specify mode. This is illustrated in the following example (cf. also Creissels 2006b and Stolz 1992):

(21) Hungarian (Hegedűs 2008, 221)

- a. *a ház mellett*  
the house beside.PLACE  
‘beside the house’
- b. *a ház mellé*  
the house beside.GOAL  
‘(to) beside the house’
- c. *a ház mellől*  
the house beside.SOURCE  
‘from beside the house’

As shown in (21), the adposition stem expresses configuration whereas its different case forms distinguish between modes. Thus, instead of combining with all ten spatial cases that are available in Hungarian, the case paradigm of Hungarian postpositions only makes a three-way mode distinction.<sup>5</sup> This reduced spatial case paradigm can easily be explained from a functional perspective: Spatial adpositions in Hungarian make

<sup>5</sup> We find a comparable situation in Finnish, discussed in Lestrade 2010. For a cross-linguistic overview of the distribution of labor between cases and adpositions within complex spatial PPs, cf. Lestrade et al. 2011.

a much more fine-grained distinction in configuration than spatial cases. The very general configuration distinctions that are made by the nominal spatial case paradigm are therefore redundant on adpositions and only a mode distinction is necessary (cf. also the argumentation in Section 3.2). Importantly, Place is one of the mode distinctions that are formally distinguished in the case paradigms of these adpositions, not one of the configuration distinctions that are omitted. This again suggests that, in Hungarian, Place belongs to the mode domain, taking configurations as its input.

## **4 Discussion**

Above, we have seen evidence for different proposals for the analysis of Place. In this section an attempt is made to link these various systems in a diachronic sketch of the possible development of Place.

It can be hypothesized that Place first emerges in a language as the result of a grammaticalization process in which the most frequently used configurational expression grammaticalized to such an extent that it no longer inherently expressed any distinction whatsoever (cf. a.o. Lehmann, 1985). Place, at this stage, has become a generalized configuration, its locative function and mode interpretation resulting from contextual enrichment. In the development of new configuration markers, necessary to communicate specific configurational meaning, Place-as-a-generalized-configuration could be used to explicitly mark these markers for their new role. Thus, Place comes to express the locative function. Malayalam, discussed in Section 3.3, possibly could be said to illustrate this transition stage. In a next stage of grammaticalization, a language may develop a morphological mode system to provide a temporal specification of this Place-with-the-locative-function in combination with motion events. Languages may develop a Source marker that restricts the Locative function to a (time) interval before a change and/or a Goal marker that restricts it to an interval after a change. Since Source and Goal have the Locative function as their default input, their markers can either be used on top of the former locative marker (reflecting their semantic relation), or in contrast with it (as the default input of a function need not be expressed).

Interestingly, the two case systems that emerge at this point in our sketch nicely correspond to the syncretism patterns that are attested cross-linguistically. If only a two-way mode distinction is made with a special Source marker, the former locative marker will come to express non-Source mode, i. e. be compatible with Place and Goal. If, on the other hand, a two-way mode distinction is made with a special Goal marker

only, the former locative marker expresses non-Goal mode, i. e. Place and Source. What is not expected is the development of a mode function that only says that the locative function should be linked to a motion event instead of a stative one. As explained in the introduction, this is not very informative and therefore such a marker is unlikely to develop. Indeed, virtually the only attested spatial syncretism patterns are between Place and Source or Place and Goal (cf. Stolz 1992; Creissels 2009; Pantcheva 2010; Lestrade 2010; cf. Kutscher 2010 for a synchronous exception that can be explained away via phonological attrition). If a second mode distinction is developed (Source, if Goal was already there and vice versa), the Place-with-the-locative-function marker will first express Place by pragmatic reasoning only: If the location is not restricted to a subinterval, it is interpreted as holding throughout the event. Eventually, however, Place-with-the-locative-function can be expected to end up expressing a mode distinction directly by semantic strengthening, that is, by not deriving the Place-as-a-mode interpretation indirectly, but by establishing the link in its lexical semantics. Thus, Place-as-a-mode could be considered to be the fossilized version of Place-with-the-locative function and should only emerge in mode systems in which the two other basic modes Goal and Source are developed first (cf. Wilkins and Hill 1995 for such a diachronic relation between a “pragmatic” and a “semantic” phase; cf. Blutner 2007 for a similar use of the notion *fossilization*).

The following example may illustrate this last stage of the development in progress. As shown in (22b) for Goal only, in Imonda the markers for Goal and Source are used on top of the Place marker, whose independent use is illustrated in (22a). However, as (22c) shows, sometimes it is possible to omit the latter and use the Goal marker directly on the ground.

(22) Imonda (Seiler 1965)

- a. *iéf-ia*  
house-LOC  
'at the house' (p. 71)
- b. *Iéf-ia-m*            *ka*    *uagl-f*  
house-LOC-Goal    I        go-PRES  
'I am going home.' (p. 161)
- c. *Ně-m*                *at*    *uagl-n*  
bush-Goal            COM    go-PAST  
'He has gone to the bush.' (p. 161)

The optionality of the locative marker could be understood as the beginning of a process in which the Place marker changes from the input of the modes Goal and Source into a mode distinction proper: If (22a) and (22c) are contrasted, one could say that Place and Goal are developing a complementary distribution, which may subsequently lead to their equivalent status semantically.

## 5 Conclusion

This paper discussed the status of Place markers in a cross-linguistic sample of spatial-case inventories. It was proposed that a uniform analysis of Place cannot be given but that languages may have very different spatial systems instead. In some, Place should be considered a generalized location, in others, it can have a locative function explicitly establishing the link between locatum a location, and in again other languages, Place may function as a full-fledged mode distinction contrasting with Goal and Source meanings that are universally accepted as modes. Thus, in some languages the mode dimension is obligatorily marked whereas in others this is only done when deemed necessary.

The different options were hypothesized to be diachronic variants rather than (onto)-logical opposites. Place may start out as the result of the interpretation of the locative function in a system of pragmatic contrasts with Source and Goal. From this, it can be expected to develop its own inherent mode semantics by pragmatic strengthening.

Whether this grammaticalization hypothesis is right or wrong, our semantic representations of spatial meaning should probably at least have the possibility of allowing Place as mode distinction to account for the variation described here.

## 6 References

- Asher, R. E. & T. C. Kumari. (1997). *Malayalam*. London and New York: Routledge.
- Bateman, J. A. (2010) Language and Space: A two-level semantic approach based on principles of ontological engineering. *Speech Technology* 13: 29–48.
- Creary, L. G., Gawron, J. M., & Nerbonne, J. (1989). Reference to locations. In *Proceedings of the 27th Annual Meeting of the ALC*, Vancouver (p. 42–50).
- Creissels, D. (2004). Non-canonical applicatives and focalization in Tswana. Paper presented at *Syntax of the world's languages*, Leipzig, August 5–8, 2004.
- Creissels, D. (2006a). Encoding the distinction between location, source and destination. A typological study. In M. Hickmann & S. Robert (Eds.), *Space in languages: Linguis-*

- tic systems and cognitive categories* (p. 19–28). Amsterdam and Philadelphia: John Benjamins.
- Creissels, D. (2006b). Suffixes casuels et postpositions en hongrois. *Bulletin de la société de linguistique de Paris*, 101(1), 225–272.
- Creissels, D. (2009b). Spatial cases. In A. Malchukov & A. Spencer (Eds.), *The Oxford handbook of case* (p. 609–625). Oxford: Oxford University Press.
- Hendriks, P. de Hoop, H., Krämer, I., de Swart, H., and Zwarts, J.: *Conflicts in Interpretation*. London: Equinox publishing (2010).
- Hegedús, V. (2008). Hungarian spatial PPs. *Nordlyd: Tromsø Working Papers in Linguistics*, 33(2), 220–233.
- de Hoop, H., & Zwarts, J. (2009). Case in formal semantics. In A. Malchukov & A. Spencer (Eds.), *The Oxford handbook of case* (p. 170–184). Oxford: Oxford University Press.
- Jackendoff, R. (1983). *Semantics and cognition* (8th ed.). Cambridge: MIT Press.
- Jackendoff, R. (1990). *Semantic structures*. Cambridge: MIT Press.
- Kiparsky, P. (2012). Grammaticalization as optimization. In D. Jonas, J. Whitman and A. Garrett (eds.) *Grammatical Change: Origins, Nature, Outcomes*, Oxford: Oxford University Press.
- Kracht, M. (2002). On the semantics of locatives. *Linguistics and Philosophy*, 25 (2), 175–232.
- Kracht, M. (2008). The fine structure of spatial expressions. In A. Asbury, J. Dotla?il, B. Gehrke, & R. Nouwen (Eds.), *The syntax and semantics of spatial P* [Linguistik Aktuell/Linguistics today 120] (p. 35–62). Amsterdam: John Benjamins.
- Kutscher, S. (2010). When ‘towards’ means ‘away from’: The case of directional-ablative syncretism in the Ardeşen variety of Laz (South-Caucasian). (Manuscript, Humboldt University Berlin).
- Lehmann, C. 1985. Grammaticalization: Synchronic variation and diachronic change. *Lingua e stile a XX* (3). 303–318
- Lestrade, S. (2012) "A linguistic ontology of mode: The use of locations in spatial language". In: C. Stachniss, K. Schill, and D. Uttal (Eds) *Spatial Cognition 2012*, LNAI 7463, 319–337. Springer, Heidelberg.
- Lestrade, S. (2011) "Analyzing directionality: From paths to locations". In: Joana Hois, Robert J. Ross, John Kelleher, and John Bateman (Eds), *Proceedings of the 2nd Workshop on Computational Models of Spatial Language Interpretation and Generation (CoSLI-2)*, Boston, MA.



- Lestrade, S. (2010) *The space of case*. PhD Thesis, Radboud University Nijmegen.
- Lestrade, S., de Schepper, K., & Zwarts, J. (to appear). The distribution of labor between adpositions and case within complex spatial PPs. (*STUF – Language Typology and Universals*).
- Nordlinger, R. (1998). *Constructive case. Evidence from Australian languages*. Stanford: CSLI Publications.
- Plank, F. (Ed.). (1995). *Double case. Agreement by Suffixaufnahme*. New York and Oxford: Oxford University press.
- Reshöft, N. and Lestrade, S. (2013). "Zur lexikalischen Semantik von Bewegungsverben: Die Wörterbuch-Methode". In: Aina Urdze (Ed.). *Linguistik im Nordwesten: Beiträge zum 4. Nordwestdeutschen Linguistischen Kolloquium*. Bochum: Universitätsverlag Dr. N. Brockmeyer.
- Schank, R. (1973). Identification of conceptualizations underlying natural language. In Roger Schank & K. Colby (Eds.), *Computer models of thought and language*, 187–248. New York: W. H. Freeman and Co.
- Seiler, W. (1985). *Imonda, a Papuan language*. Canberra: Department of Linguistics, Research School of Pacific Studies, Australian National University.
- Sulkala, H., & Karjalainen, M. (1992). *Finnish*. London: Routledge.
- Wilkins, D. P., & Hill, D. (1995). When "go" means "come": Questioning the basicness of basic motion verbs. *Cognitive Linguistics*, 6, 209–59.
- Wunderlich, D. (1991). How do prepositional phrases fit into compositional syntax and semantics? *Linguistics*, 29 591–621.
- Zwarts, J. (1997). Vectors as relative positions: A compositional semantics of modified PPs. *Semantics*, 14 , 57–86.
- Zwarts, J. (2005). Prepositional aspect and the algebra of paths. *Linguistics and Philosophy* 28. 739–779.



ANDREA BELLAVIA

Force Change Schemas and Excessive Actions:  
How High-Level Cognitive Operations  
Constrain Aspect in Idiomatic Constructions

Andrea Bellavia  
Universitat Autònoma de Barcelona  
Centre de Lingüística Teòrica

bellavia.andrea@gmail.com

**Abstract**

Aspectuality has been claimed to be determined by the same principles in both literal and idiomatic readings of equivalent structures. In this paper, we analyze the English V one's BODY PART out/off idioms which correspond to a pattern of intensive meaning construction involving a change in the interpretation of the aspectual classes of their VPs. This class of idiomatic constructions denotes systematically a change of location undergone by a body part at the source domain which is metaphorically projected into the target domain which denotes an event carried out in an intensive fashion. The activation of metaphorical modes of thought is the foundation of the two-level integration model advanced here as a semantic compositional representation (semantic pole) of the idiomatic constructions. The model, blended in nature, gives rise to emergent structures which are foregrounded with respect to the unitary integration process. The interaction between the cognitive operations involved in the construction of the final idiomatic meaning is argued to motivate the shifts toward atelicity of the idioms analyzed.

Keywords: Lexical Aspect; Aspectual Shifts; Idioms; Cognitive Grammar; Fake Resultatives

## 1 Introduction

The main question to be addressed in this paper is whether the aspectual properties of idiomatic constructions can be determined according to the same principles we would use for non-idiomatic ones. We take the issue by focusing on a specific pattern of intensive meaning construction in English: the V one's body part out/off idioms. In particular, we provide an analysis of constructions of the type *John laughed his head off* ('John laughed intensely/a lot') and *she cried her eyes out* ('She cried a lot') where the intensity of the action is systematically conveyed by a caused removal of a body part expressed in the linguistic structure.

The activation of this metaphorical mapping has consequences for the conceptual interpretation of aspect which appears to be constrained by high-level cognitive operations. In fact, under the literal reading of a construction containing the same VP (e.g. the audience laughed the actor off the stage), a different aspectual class would be involved. In more detail, under the idiomatic reading, the (unreal) eventuality can be associated to an atelic resultative construction (a fake resultative in terms of Jackendoff 1997) while under the literal reading the sentence can be defined as a telic resultative construction. These aspectual shifts have been motivated by advancing metaphorical modes of thought dynamically activated in the process of idiom comprehension (Mateu & Espinal to appear, 2010 after Gibbs 1994, Lakoff 1993, Lakoff & Johnson 1999).

The formulation of the metaphor an intensive action is a change of location (Mateu & Espinal 2010) will be the basis for the application of the so-called Force Change Schema (Broccias 2003) used as the semantic pole for resultative constructions and adapted to the data discussed in the present study to propose a possible compositional path for their idiomatic meaning. The model, structured by two level of successive conceptual integration, will be advanced as a schematic representation for the meaning implications involved in the idiomatic pattern. The general goal of this paper is to investigate the cognitive operations involved in the conceptual interpretation of the aspectual properties related to different classes of predicates and to account for the shifts toward atelicity which affect certain classes of idioms like the ones under examination. We begin by discussing the notion of lexical aspect and its relevance within the Cognitive Linguistics framework in subsection 2.1.

In subsection 2.2, we provide an overview of previous accounts which have specifically dealt with idioms and aspectuality. In particular, we will consider as valid metaphorically driven approaches to idiomatic interpretation (Espinal & Mateu 2010) as opposed to formal treatments of idioms (Jackendoff 1997, McGinnis 2005, Glasbey 2003) which see idiomatic meaning as a combination of the properties of their syntactic constituents. In section 3, (i) we advance our proposal by introducing the problem of aspectual shifts and examining the cognitive operations involved in idiom comprehension and (ii) we introduce the two-level integration model as a heuristic representation of their semantics. We conclude with some final comments conclusions in section 4.

## 2 Background

### 2.1 The Inherent Structure of Events

The first point that we feel the need to clarify for a proper coverage of the topic is the distinction between the notions of grammatical aspect and lexical aspect (or *Aktionsart*). In the Cognitive Linguistics literature, scholars do not always support the different implications of the separation between the two types of aspect and this is not astonishing given the impossibility to mark a clear-cut grammar/lexicon distinction (Boogart and Janssen 2007). However, when it comes to aspectual shifts, we assume Vendler's classification (Vendler 1967), and implicitly the relevance of lexical aspect, for two main reasons.

First, we argue that there is a correlation between the inherent structure of events and the typical abilities for apprehending and tracking relationships claimed in Cognitive Grammar, namely the notion of scanning (Langacker 2008: 111). In fact, how component states of an event are accessed and conceptualized crucially relates to the binary properties assigned to the aspectual classes. Second, we endorse the definition of aspect provided in Croft (2012) according to which lexical aspect describes how events are construed as unfolding over time and, thus, a two-dimensional analysis of aspectual types is required in order to investigate the semantic complexity of aspect and the conceptualization processes that intervene in the relationship between aspect and *Aktionsart*. Basically, two general approaches to aspect can be distinguished in the literature (Croft 2012, Michaelis 2004): unidimensional and bidimensional. In unidimensional approaches, there is no difference between the semantics of grammatical and lexical aspect. In bidimensional approaches the two types of aspect are semantically distinct. In the present account, we assume Croft's (2012) construal approach according to which aspectuality has to be defined according to the semantic structure of predicates and inferred from the interpretations of predicates in different tense/aspect constructions. In other words, events may involve different perspectives, and then the possibility of viewpoint shifts in terms of aspectual construals is fundamental to capture the differences in the inherent structure of events. Since the analysis presented here is essentially focused on the lexical aspect of different classes of predicates, we assume as a starting point the basic Vendlerian classification into four different categories of lexical aspect.

- (1) States: be sick [stative, durative, atelic]
- (2) Activities: sing, run [non-stative, durative, atelic]

- (3) Achievements: sink [non-stative, punctual, telic]
- (4) Accomplishments: build [non-stative, durative, telic]

Generally speaking, these classes are defined according to three binary distinctions: stative/non-stative, punctual/durative, telic/atelic. The present analysis is concerned with detelicization processes in idiomatic contexts, namely aspectual shifts from a telic to an atelic interpretation of a predicate when an idiomatic expression has the same syntactic structure, or at least the same verb phrase, as a non-idiomatic counterpart.

In particular, states describe situations that are both stative and durative since they do not change and last over time. Activities describe both dynamic events and processes and involve a change over time. Additionally they do not have an inherent endpoint. Processes are also instantiated by the Achievement class but provide as well a culmination of the event in a punctual point in time. Accomplishments involve a process resulting in a change of state that lasts in time. The typical diagnostic procedure to define the aspectual class of a verb is the modification by the container and durative adverbials (Croft 2012). The *in*-phrase and *for*-phrase modification (as originally dubbed in Vendler 1967), commonly used to distinguish between telic and atelic events, indicate respectively the length and the span of time over which the event occurred.

These diagnostics will provide the analysis with crucial insights to define the aspectual properties of the data discussed in the present paper. Other methodologies have been applied to define more specifically the properties of the four categories, even though their semantics may overlap and, accordingly, the predicates may belong to different aspectual classes. This comes as no surprise given the fact that each category shares at least one property with the other three categories part of the taxonomy. Now, we are going to describe how this potential overlapping has been diagnostically disentangled. The present progressive *what are you doing?* test has been applied with respect to the stative/non-stative distinction, and in particular to differentiate states (to know) from activities (to laugh), since both are durative and atelic but display a divergence in terms of the dynamicity of the event.

- (5) What are you doing? \*I am knowing.
- (6) What are you doing? I am laughing.

Finally, two other tests are used to make a distinction on the one hand between accomplishments and the other three categories, on the other hand between states and the rest of the taxonomy: *it took me/him/her/us-TIME INTERVAL-to* test and *do you - STATE?* test.

- (7) It took them two months to build the castle.
- (8) Do you know the truth? Yes, I do.

Vendler (1967) posits other diagnostic questions to distinguish achievements from states. The *at what moment?*-test and the *for how long?*-test are used to point out the compatibility of achievements with the first temporal question while states are fine if modified by the second one. Inverting the test to evaluate the nature of the predicates for the two classes will lead to semantic inappropriateness, or more drastically to ungrammaticality.

- (9) At what moment did the ship sink?/\*At what moment have you been sick?
- (10) For how long have you been sick?/\*For how long did the ship sink?

However, even if helpful, the above-mentioned tests do not solve completely the exact attribution of the aspectual properties to the individual classes, being this an operation crucially influenced by usage-based facets and viewpoint factors, besides the morphological/inflectional elements that, in some languages, play a role in the definition of aspect (Dahl 1985).

## **2.2 A Conceptual Metaphor Account of Aspectuality**

The model presented in this paper to account for the cognitive operations that intervene in the conceptual interpretation of aspect and constrain the attribution of the aspectual class to the VP in idiomatic context, is based on a previous analysis advanced in Espinal & Mateu (2010) and Mateu & Espinal (to appear) which has posited the activation of metaphorical modes of thought as the fundamental motivation for the atelicity of idioms like (11) and (12).

- (11) John worked his guts out all day long/\*in ten minutes.
- (12) John laughed his butt off all day long/\*in ten minutes.

(Mateu and Espinal to appear)

In particular, the above sentences, which appear to fall in the class of fake resultatives, are compared to telic resultative constructions in (13) and (14) associated to literal interpretations.

- (13) The audience laughed the actor off the stage in/\*for ten seconds.
- (14) She worked the splinter out of her finger in/\*for ten seconds.

(Mateu and Espinal to appear)

By claiming the activation of conceptual metaphors, the study demonstrates how the idiomatic readings in (11) and (12) can be associated to durative activities (given also

possibility to modify the sentence by a for-phrase) and goes beyond Jackendoff's claim that VPs in fake resultatives like are interpreted as "V excessively" and Glasbey (2003)'s argument according to which in the non-literal sentences there is no gradual patient relationship. The intuition to deal with fake resultatives in terms of conceptual metaphor is inspired by Goldberg (1995)'s account of true resultatives, which in her Construction Grammar approach are seen as a metaphorical extension of the caused-motion constructions of the type John kicked the bottle into the yard. Resorting to the basic conceptual metaphor change of state is a change of location the resultative construction structure is 'inherited' from the caused-motion. Different formulations of the specific conceptual metaphors involved in the interpretation of the idioms in (11) and (12) are provided in Espinal & Mateu (2010). First, the conceptual mappings involve the primary metaphor the body as a container since a figurative extraction of body part from the container occurs at the source domain and is mapped into the target domain that is the more abstract intense action. In their terms, the action carried out in an excessive fashion is expressed in the linguistic structure by a displacement of a body part.

(15) AN INTENSE ACTIVITY IS AN EXCESSIVE DETACHMENT (OR EXHAUSTION) OF A BODY PART

The metaphor as formulated in (15) is a subset of the more general (complex) conceptual metaphor in (16) which is responsible for the interpretation of idioms like (11) and (12) as durative activities.

(16) AN INTENSE ACTIVITY IS AN EXCESSIVE CAUSED CHANGE OF LOCATION/STATE

In particular, the change of location denoted by the directional paths (out or off) is projected into the domain of the activity, characterized as 'so intense that they appear to lack boundaries' (Mateu & Espinal to appear). We acknowledge the role of the conceptual metaphor in the definition of aspect in idiomatic contexts but at the same time we claim that it is insufficient to account exhaustively for the cognitive modes of thought involved in meaning construction which constrain the final atelic interpretation of the idiomatic constructions.

### 3 A Conceptual Analysis of Aspectual Shifts

In the present study, an aspectual shift is claimed to occur (in certain classes of idioms) when a VP, that allows both a literal and an idiomatic reading, can be associated to



different aspectual classes depending on the interpretation that is accessed according to contextual information and communicative purposes. More classes of idioms have been argued to be affected by aspectual shifts toward telicity. The V one's BODY PART idioms, examined in the present paper after Espinal & Mateu (2010), are one of those classes. Furthermore, relevant counter-examples, undergoing the same types of shifts and involving the same patterns of conceptual interaction have been proposed for Romance languages (e. g. Italian, see Bellavia 2012). Let us take into analysis the following minimal pair:

- (17) The audience laughed the actor off the stage in ten seconds/\*for then seconds.  
(18) John laughed his head off for ten seconds/\*in ten seconds.

The verb *to laugh* under the literal and the idiomatic readings is associated to two different aspectual classes, respectively. In (17), the possibility to modify the event by using an in-phrase adverbial allows us to define it as telic (accomplishment). The same cannot be said for (18), where the VP under the idiomatic interpretation denotes a durative activity. The problem at issue is complex and relates to different factors. First of all, the question we should find an answer to is how the aspectual properties of the same VP can be different in the two relevant readings. Then, we should find out whether it is a problem that can be explained by looking at the structural components of the sentence or we need to appeal to the conceptual interpretation of aspectuality.

We claim that the change in the aspectual properties can be accounted for by considering the cognitive operations involved in the conceptual mapping between two domains of experience, namely the concrete change of location expressed in the structural components of meaning and the intensity of the action expressed by the idiomatic meaning. These semantic implications are heuristically represented using a two-level model of conceptual integration where, at the first level, the integration will involve two components of meaning giving rise to the single sentence unit of the idiom like in John laughed his head off; at the second level, the integration will affect the two domains of experience implicated via metaphorical activation. The details of the semantic model are described in more detail in the next section.

Following the main tenets of Cognitive Grammar (Langacker 1987, 1991), we argue that idiomatic constructions involve at the semantic pole a complex scene that consists of a final foregrounded meaning as a result of a compositional path which corresponds to the process of assembling of their semantic structure. The purpose of the compositional path is to capture in a unitary fashion all the meaning implications, patterns of

figurations (Langlotz 2006) and cognitive operations involved in idiomatic interpretation. The phonological pole implies the same configuration as the one correspondent to a potential literal scene implied by the sentence. In this sense, the literal scene “works as the scaffolding against which the idiomatic meaning is conceived” (Langlotz 2006: 108). Once the idiomatic meaning can be accessed via patterns of figuration which provide a conceptual basis to make sense of its semantics, it will be foregrounded. In the background, the literal scene will be still available but as a more concrete domain from which the conceptual structure is imported, or – to put it in terms of Langlotz (2006) – as standard of comparison for the foregrounded idiomatic meaning.

We argue that the meaning implications involved in the idiomatic construction in (9b), carry out aspectual information and since the displacement of the body is unreal and is used as a source domain to make sense of the intensity domain, there is no endpoint involved in the idiomatic event. But the inherent scene provided by these idioms is much more complex and to represent it properly we resort to the Force Change Schema (FCS) as developed in Broccias (2003). The FCS will serve as the conceptual “scaffolding” to build up the two-level integrated model implied by the activation of the conceptual metaphor an intense action is a change of location which will give rise to the foregrounded idiomatic meaning.

To sum up: the sentence in (17) – associated to a literal reading – can be claimed to be a true resultative. We have already seen that, examples such as (18) have been defined as fake resultatives since they are conceptually associated to atelic readings and there is no semantic relation between the V and the NP. More precisely, there is no semantic constraint of patienthood over the NP (Goldberg 1995: 99–100).

The FCS has been proposed to represent the semantic pole of transitive resultative constructions (Broccias 2003: 52) as in the following examples:

(19) John hammered the metal flat.

(20) Sally danced herself to fame.

Interestingly enough, a crucial distinction between (19) and (20) is pointed out in Broccias (2003: 178). The former conveys a visible condition, the latter a not visible condition. When a not visible condition is involved the event is said to be carried out in an above-the-norm fashion.

The FCS is a composite structure which results from the integration (in terms of Fauconnier & Turner 1996) of a force component (FC) and a change component (CC). In a sentence like (17), the FC is the *audience laughed the actor*, whereas the CC is *the actor*

*off the stage*. The V is an intransitive verb that is constructed here in a forcible fashion and, in terms of Langacker (2009: 256), can be considered as the skewing element of the construction, namely an element whose the composite meaning of the expression it appears in is incongruent with respect to the verb's meaning. The schema in Figure 1 represents the FCS and it is related to the true resultative construction of the literal reading in (17). At the FC, the trajector the audience exerts the force instantiated by the verb laughed over the landmark the actor. At the CC, the force causes the displacement of the element that corresponds to the landmark from an origin to a goal. The path *off* is instantiated by an arrow. The entities that are not in bold are not specified in the linguistic structure. In this sense, even if *off the stage* could be considered as the resultant state, no specific entity representing the goal is expressed in the sentence. The dotted lines indicate the correspondences between the entities of the two components that are integrated in the single conceptual unit (the blend).

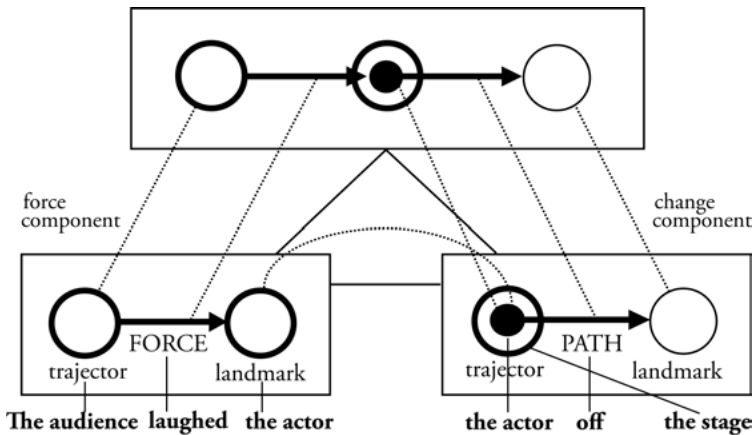

Figure 1: The audience laughed the actor off the stage

The point we make in the present paper is based on an extended version of the FCS consisting of two levels of integration obtained via metaphorical activation. The two-level model provides a schematic description of the semantic pole of the idiomatic construction in (18) and is representative of fake resultatives. As represented in Figure 2, at the first level (exactly like the literal reading) the integration between the FC and the CC results into a single conceptual unit. Thus, we have a force exertion of the verb *to laugh* from the trajector *John* over the landmark head at the FC, and a displacement (head off) from an origin toward a goal at the CC. Given the coreferentiality of the

possessive determiner with the subject the origin coincides with the trajector. We claim that the first-level integration occurs within the source domain that is the change of location.

The interaction of this domain with the target domain intensity conceptualized via the image-schematic structure scale, giving rise to the final level of integration where the event itself of laughing is argued to assume the role of trajector moving along the open-ended scale of intensity and providing, thus, no inherent endpoint in the event. In fact, as defined in Johnson (1987: 123) the image schema scale may either continue indefinitely in one direction or may terminate at a definite point. The concept of intensity has been defined in the literature as open-ended, hence we stipulate the indefinite value of the abstract concept ( $\infty$ ) expressed by the intense action. Still, the dotted lines indicate the correspondences between the entities of the two components that are integrated into a single conceptual unit.

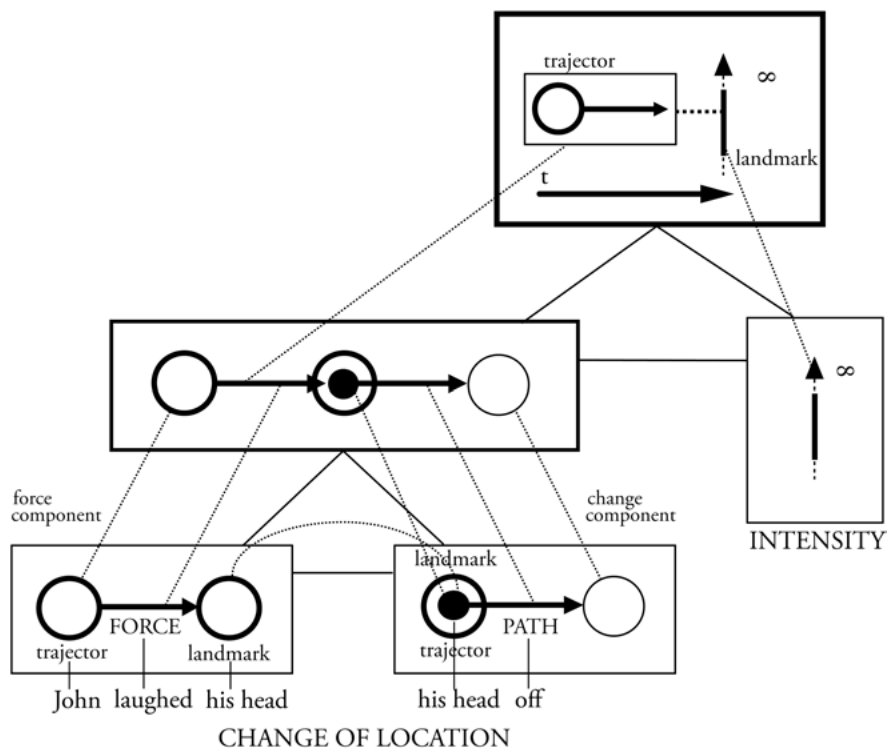

Figure 2: John laughed his head off

The single conceptual unit of the second-level integration will be the salient part corresponding to the foregrounded idiomatic meaning. Blended spaces are the result of projecting source domain onto target domains. Furthermore, conceptual units which are the result of blending operations are hybrid (Langacker 2008: 51) in the sense that they combine and foreground selected features of each input space. In the same way, at the end of idiom comprehension, the speaker will select the intense activity because the final level of integration will be in the foreground.

#### **4 Final Comments**

The proposal advanced as an account for aspectual shifts has been focused on the cognitive operations involved in idiomatic meaning construction and its processing. Our main concern has been to explain the systematicity of the expression of intensive actions via a caused removal of a body part. In this respect, we have claimed a two-level integration model as a representation of the unitary compositional paths entailed by the semantics of the V one's body part out/off idioms.

The model – based on the Force Change Schema (Broccias 2003) consisting of a single conceptual unit as a result of the integration between a force component and a change component – implies a second level of integration given by the activation of the conceptual metaphor an intense action is a change of location, first proposed in Espinal and Mateu (2010). The atelicity of the events has been assumed to be caused by the unbounded nature of the concept of intensity involved in the target domain. We have also argued that the conceptual mappings allow the different experiential domains to be integrated in an emergent structure that, given its complex blended nature, results in a foregrounded space, namely the final level of idiom processing.

#### **Acknowledgements**

Many thanks to Maria Teresa Espinal and Jaume Mateu for enlightening conversations and support. I would also like to thank the organizers and the audience of the SMCLC 2011 for comments and interesting issues raised after my talk. The present work has received financial support from the Spanish Ministerio de Economía y Competitividad (grant FFI2011-23356/FILO) and the Generalitat de Catalunya AGAUR (grant FI-DGR 2011). All errors are my own.

## References

- Bellavia, A. (2012). Detelicization Processes in Idiomatic Constructions: A Cognitive Grammar Approach. In B. Surányi & D. Varga (Eds.), *Proceedings of the First Central Europe – an Conference in Linguistics for postgraduate Students*. Budapest: Pázmány Péter Catholic University.
- Boogart, R., Janssen, T. (2007). Tense and Aspect. In D. Geeraerts & H. Cuyckens (Eds.), *The Oxford Handbook of Cognitive Linguistics* (pp. 803–828). Oxford: Oxford University Press.
- Broccias, C. (2003). *The English Change Network*. Berlin/New York: Mouton de Gruyter. Croft, W. (2012). *Verbs: Aspect and Clausal Structure*. Oxford: Oxford University Press. Dahl, Ö. (1985). *Tense and Aspect Systems*. Oxford: Blackwell.
- Espinal, M. T., Mateu, J. (2010). On classes of idioms and their interpretation. *Pragmatics* 42, 1397–1411.
- Fauconnier, G. (2009). Generalized integration networks. In V. Evans & S. Pourcel (Eds.), *New Directions in Cognitive Linguistics*. Amsterdam/Philadelphia: John Benjamins.
- Gibbs, Raymond. 1994. *The Poetics of Mind*. Cambridge/New York: Cambridge University Press.
- Gibbs R., Bogdonovich, J., Sykes J., Barr, D. (1997). Metaphor in idiom comprehension. *Memory and Language*, 37, 141–154.
- Glasbey, S. (2003). Let's paint the town red for a few hours: composition of aspect in idioms. In A. Wallington (Ed.), *Proceedings of the ACL Workshop: The Lexicon and Figurative Language*, Sapporo, 42–48.
- Glasbey, S. (2007). Aspectual composition in idioms. In Louis de Saussure, J. Moeschler & G. Puskas (Eds.), *Recent Advances in the Syntax and Semantics of Tense, Aspect and Modality*. Berlin: Mouton de Gruyter.
- Goldberg, A. (1995). *Constructions. A Construction Grammar Approach to Argument Structure*. Chicago: The University of Chicago Press.
- Jackendoff, R. (1997). Twistin' the night away. *Language* 73, 534–559.
- Johnson, M. (1987). *The Body in the Mind. The Bodily Basis of Meaning, Imagination, and Reason*. Chicago: The University of Chicago Press.
- Lakoff, G., & Johnson, M. (1980). *Metaphors We Live By*. Chicago: The University of Chicago Press.
- Lakoff, G., (1993). The contemporary theory of metaphor. In A. Ortony (Ed.), *Metaphor and Thought*. Cambridge: Cambridge University Press.

- Langacker, R. W. (1987). *Foundations of Cognitive Grammar, Vol. 1. Theoretical Prerequisites*. Stanford, CA: Stanford University Press.
- Langacker, R. W. (1991). *Foundations of Cognitive Grammar, Vol. 2. Descriptive Application*. Stanford: Stanford University Press.
- Langacker, R. W. (2008). *Cognitive Grammar. A Basic Introduction*. New York: Oxford University Press.
- Langacker, R. W. (2009). Constructions and constructional meaning. In V. Evans & Stéphanie Pourcel (Eds.), *New Directions in Cognitive Linguistics*. Amsterdam/Philadelphia: John Benjamins.
- Langlotz, A. (2006). *Idiomatic Creativity: A Cognitive Linguistic Model of Idiom-Representations and Idiom-Variation in English*. Amsterdam and Philadelphia: John Benjamins.
- Mateu, J., Espinal, M. T. (to appear). Laughing our heads off: When metaphor constrains aspect. In *Proceedings of the 33rd Annual Meeting of the Berkeley Linguistics Society*. Berkeley, CA.
- Langlotz, A. (2006). *Idiomatic Creativity: A Cognitive-linguistic model of Idiom representation and idiom variation in English*. Amsterdam and Philadelphia: John Benjamins.
- McGinnis, M. (2002). On the systematic aspect of idioms. *Linguistic Inquiry* 33 (4), 665–672.
- Michaelis, L. A. (2004). Type shifting in construction grammar: An integrated approach to aspectual coercion. *Cognitive Linguistics*, 15–1, 1–67.
- Vendler, Z. (1967). *Linguistics in Philosophy*. Ithaca and London: Cornell University Press.





**SENSORY-MOTOR CONCEPTS AND  
PERCEPTION**



LIONEL BRUNEL, DENIS BROUILLET AND RÉMY VERSACE

## The Sensory Nature of Knowledge

Lionel Brunel  
University of Montpellier 3  
Epsilon Laboratory

Lionel.brunel@univ-montp3.fr

Denis Brouillet  
University of Montpellier 3  
Epsilon Laboratory

Denis.brouillet@univ-montp3.fr

Rémy Versace  
University of Lyon 2  
EMC Laboratory

Remy.versace@univ-lyon2.fr

### Abstract

The aims of the present studies are to assess the sensory nature hypothesis of knowledge through a series of experimental results. Especially, we investigated the links between memory and perception using a short-term priming paradigm based on a previous learning phase consisting of the association between a geometrical shape and a white noise. Consequently, the priming phase examined the effect of a geometrical shape, seen in the learning phase, on the processing of a target (tones or picture). Our main results demonstrate that memory and perception share some mechanisms and at least components. These ones are involved for the processing of each form of knowledge (i. e., episodic and semantic). At last, reflections about the implication of this work to study perceptual learning and memory are presented.

Keywords: Perception, Integration, Multisensory Memory

## 1 Introduction

How do people represent information in memory? What is the nature of the information stored in memory? We can consider that learning representations or concepts depends on upon perceptual experiences. In that view, the comprehension of the relation between memory (*i. e.*, concepts) and perception (*i. e.*, percepts) is critical. Classically, perception and memory are vertically described. In that case, perception extracts perceptual units from the environment thanks to *bottom-up* processes. These units are then converted into representations and are stored into memory. In return, the activation of these representations can influence the perception thanks to *top-down* processes. In that conception, the differences between memory and perception are both structural and functional (*e. g.*, Humphreys & Riddoch, 1987). Regarding the structural distinction,

recent neuroimaging studies suggest that both memory and perception share common brain areas (for a review, see Versace, Labeye, Badard & Rose, 2009). For instance, Martin and collaborators (2000) showed that conceptual processes (*i. e.*, word-object naming) and perceptual processes (*i. e.*, picture-object naming) involve the same brain area, depending on the perceptual (*i. e.*, color) and motor properties of the objects. Regarding the functional distinction, recent neuroimaging researches also suggest that the neural structures of long-term memory are involved during the perception of objects or events (see Murray & Bussey, 2007). In particular, the medial temporal lobe cortex ensures the integration of the different components of objects by means of a hierarchical integration mechanism. Recently, Shimamura and Wickens (2009) have provided evidence in support of the idea that memory activities (*e. g.*, single item recognition) might be underpinned by this integration mechanism

In this paper, we aim at developing a conception in which perception and memory are at the same functional level in cognitive architecture. In other words we want to bring experimental evidence that perception and memory act simultaneously on the same processing units. The only difference is that perception involves perceptually present units whereas memory involves reactivation or simulation of these units. Seeking this purpose, we have to provide evidence that 1) memory is able to keep traces from perceptual events; 2) memory and perception use the same processing units.

## 2 The perception leaves memory traces

In the daily life, the organism treats essentially multisensory signals. The unified perception of a multisensory environment requires not only multiple activations in the sensory areas but also the synchronization and the integration of these activations (*e. g.*, King, 2005). The existence of multisensory integration is particularly well illustrated by the McGurk effect (McGurk & Mac Donald, 1976). This effect reveals that subjects tend to perceive /da/ when they see the syllable /ga/ and hear the sound /ba/. This demonstrates the ability of a sensory system to modify the processing of another sensory system. Integration could be described as the capacity of the perceptual system to process more efficiently (or differently in case of McGurk effect) a multisensory stimulus than the sum of these two parts. Number of neurosciences studies was dedicated to the study of the multisensory integration between vision and audition. For example, King and Calvert (2001) have shown that some neurons in the superior colliculus are more highly activated by multisensory than by unisensory stimuli. Similarly, electrophysi-

ological studies have provided some evidences of audiovisual integrations (between a shape and a tone) that occur in the visual cortex after a period of just 40 ms (Giard & Perronet, 1999). In the same vein, authors have shown that spatial congruity enhances audio-visual integration (Teder-Sälejärvi, Di Russo, McDonald, & Hillyard, 2001). At last, the role of attention during perception of a multisensory event and its consecutive integration is not well established (see Fort & Giard, 2002).

If a visual stimulus and an auditory stimulus tend to be integrated during a perceptual activity (e.g., perceptual categorization or discrimination), is it possible that memory could capture this integration? Once perceived, the perceptual properties of a multisensory object can be preserved in memory in the form of a memory trace. This is due to an integration mechanism that allows for the creation of durable links between perceptual properties within the same memory representation (see Brunel, Labeye, Lesourd & Versace, 2009; Hommel, 1998; Labeye, Oker, Badard, & Versace, 2008). Contrary to simple associative learning (see Hall, 1991), once features are integrated within an exemplar, it is difficult to access the individual features (see Labeye et al., 2008; Richter & Zwaan, 2010). This new unit, once acquired, becomes a functional “building block” for subsequent processing and learning (in language, Richter & Zwaan, 2010; in memory, Labeye et al., 2008; or attention, Delvenne, Cleeremans, & Laloyaux, 2009). In this view, the integration mechanism is a fundamental mechanism of perceptual learning (see the unitization mechanism, Goldstone, 2000) or contingency learning (see Schmidt & De Houwer, 2012; Schmidt, De Houwer, & Besner, 2010). From this idea we can make the prediction that once two features have become integrated, the presence of one feature automatically suggests the presence of the other. Thus, if the simultaneously presentation of an auditory information (a sound) and a visual information (a shape) leads to the creation of a multisensory memory trace, then we can easily predict that the visual component presented alone, as a prime, should influence the perception of a sound targets. We examined this prediction through an original paradigm divided in two phases. First, a learning phase (consisting in a shape categorization task) in which we manipulated the association between a given geometrical shape and a white noise<sup>1</sup>. As a consequence, participants simply had to categorize a shape as a square or a circle (each shape was presented in different shades of gray). It is important to stress that each shape was presented during 500 ms. One of this shape was systematically associated with a white noise (presented simultaneously dur-

<sup>1</sup> A white noise is a random signal with a flat power spectral density. White noise is considered analogous to white light which contains all frequencies.

ing 500 ms), the other not. Then, a priming phase (see Figure 1) in which participants watched the geometrical shapes from the learning (as prime) and listened pure tones (as target). In this phase, participants had to discriminate the target into high-pitched or low-pitched. Our first result was a selective priming effect of the geometrical shape seen in the learning phase with a sound on the processing of targets tones.

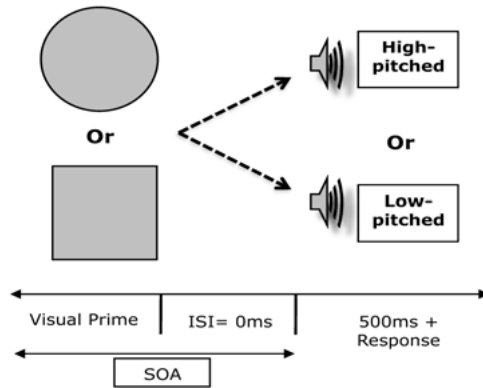

Figure 1: Organization of the priming phase. A prime shape (seen in learning phase), presented at different level SOA (100 ms or 500 ms), is immediately followed by a target tones that participants had to categorize in low or high-pitched sounds. Notes. SOA: stimulus-onset-asynchrony; ISI: Interval-Inter-Stimuli

This priming effect could be interpreted as an evidence of multisensory memory integration during perceptual learning. Indeed, when participants saw a shape that was previously presented with sound, it automatically reactivated the auditory memory component associated (see also Meyer, Baumann, Marchina & Jancke, 2007) that is able to influence the processing of targets tones. However considering only this result gave us any hint about the nature of the auditory memory component. Indeed, if memory and perception share the same processing units, then each component of the memory trace should be perceptual in nature even when they are reactivated. In order to test this assumption we manipulated the SOA during the priming phase. More specifically we predicted that reactivation of the sound should interfere with tone target processing if only if the SOA between the visual prime and the tone target is shorter than the duration of the sound associated with the shape during the learning phase. In this case, the interference effect would follow from temporal overlapping between previously associated sound reactivation and tone processing. A second and quite opposite prediction followed from different temporal constraints. Indeed, reactivation of the sound (by the visual prime) was expected to facilitate tone processing but only for

SOAs equal or longer than the duration of the sound associated with the shape during the learning phase. In this later case, not any temporal overlap occurred between simulation of the learned associated sound and target-tone processing so that target-tone processing should take advantage from the auditory preactivation induced by the prime. Our results (see Figure 2) were totally in line with these predictions.

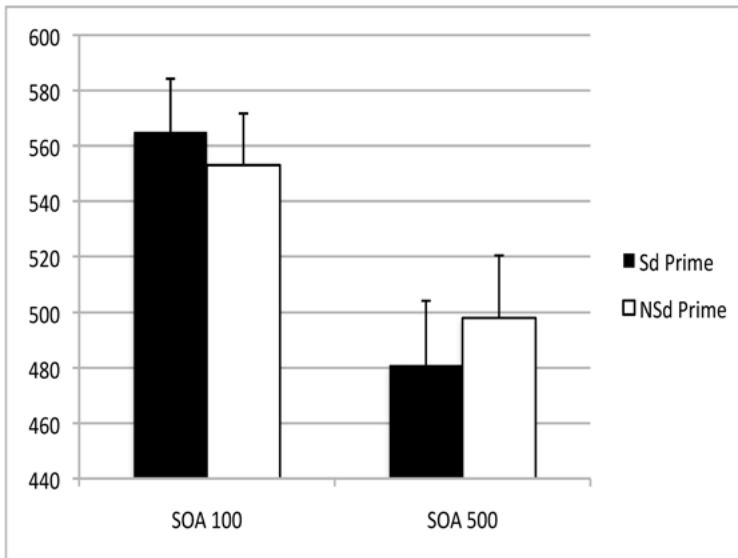

Figure 2: Interaction SOA\*Prime type  $F(1, 30) = 14.64; p < .001$ . (a) For 100 ms SOA, significant principal effect of Prime type,  $F(1, 15) = 5.25; p < .05$ . (b) For 500 ms SOA, significant principal effect of Prime type,  $F(1, 15) = 9.78; p < .01$ . Results reproduced from Experiment 1 Brunel, Labeye *et al.*, 2009. Notes. Sd Prime: prime shapes that were presented with sound during learning phase; NSd Prime: prime shapes that were presented without sound. Errors bars represent standard errors.

We demonstrated that memory keep traces from perception thanks to an integration mechanism shared by perception and memory. As a consequence, the presentation of one component of a memory trace is able to reactivate the other components (which kept all of their encoded characteristics). Once reactivated, a component is able to influence the ongoing process (see also Riou, Lesourd, Brunel & Versace, 2011). However, according to Nyberg *et al.* (2000), this kind of effect is limited to the processing of episodic knowledge and should not be observed when conceptual knowledge are at stake. Indeed, only episodic knowledge should keep some perceptual properties of former perceptual events. Such claim suggests the existence of modal and amodal forms of knowledge. The next section will be dedicated to this specific issue.

### 3 The Sensory Nature of Knowledge

What is the nature of our knowledge? Bring an answer to that question is not easy and suggests at least two different perspectives. First, we could consider that each form of knowledge is qualitatively different and as a consequence differs into their nature (i. e., modal vs. amodal). According to Tulving (1995), our knowledge could be viewed as semantic or episodic. These two sorts of knowledge depend on the existence of two independent memory systems. The semantic memory system is more likely to be involved in the processing of general amodal knowledge whereas the episodic memory system is involved in the processing of specific modal knowledge. Whereas Tulving argued that these two kinds of memory are dissociated and differ in the abstractness of the information they retain, increasing numbers of studies have demonstrated the existence of conceptual representations which nevertheless continue to possess a perceptual nature (Barsalou, 2005; Barsalou, 2008; Barsalou, Simmons, Barbey, & Wilson, 2003). Indeed, there is experimental evidence showing that the reactivation of perceptual or body states facilitates later conceptual processing for those concepts that share the same perceptual characteristics as the reactivated ones (see Pecher et al., 2004; Vandantzig et al., 2008). In that view, memory processes are deeply rooted in perceptual and action systems (see Barsalou, 2008) and, as consequence, access to all forms of knowledge is linked with automatic reactivation of perceptual or body states. In that context we can predict that conceptual processing involve automatic reactivation which is not limited to a given sensory memory component but should be observed for each diagnostic sensory component associated with a particular concept.

In order to test that prediction, we designed an experiment based on the same paradigm we described in the previous section. The learning phase is still consisting in learning an incident association between a geometrical shape and a white noise. The second phase consisted of a short-term priming paradigm (see Figure 4) in which a shape, either associated or not with a sound in the first phase, preceded an object-picture. The participants had to categorize this picture as representing either a large or a small object (more or less than 50 cm high). We manipulated the SOA as well as the nature of the object so that half of the objects were typically “noisy” objects (e. g., a blender) whereas the others were typically silent (e. g., a screwdriver). In order to perform the task, participants had to recognize the object and reactivate the actual size of the object. However, if this reactivation is not limited to the visual component and can spread to others diagnostic components (here auditory), we should observe the



same pattern of priming effect as described in the previous section but limited to the typically “noisy” targets.

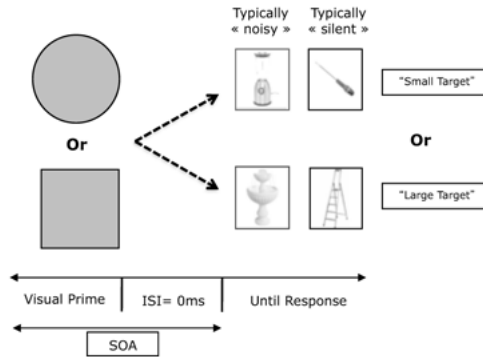

Figure 3: Organization of the priming phase. A prime shape (seen in learning phase), presented at different level SOA (100 ms or 500 ms), is immediately followed by a target picture that participants had to categorize in small or large target.

As depicted in Figure 4, we found a priming effect due to the reactivation of a memory auditory component by the visual sound prime (i.e., the shape seen with sound during the learning phase) and limited to the “noisy” targets. As we expected, this effect was modulated by the SOA. Indeed, we found an interference effect with a SOA of 100 ms (Panel A) and a facilitation effect with a SOA of 500 ms (Panel B).

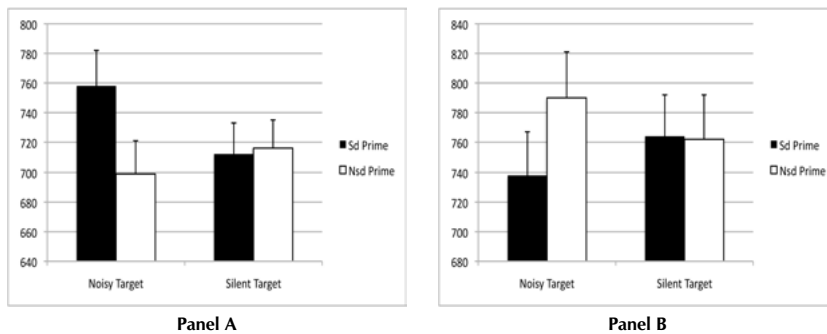

Figure 4: **Panel A:** Interaction Prime type\* Target type  $F(1, 15) = 10.6 ; p < .01$  (a) For Noisy target, significant principal effect of Prime type,  $F(1, 15) = 10.6, p < .01$ . (b) For Silent Target,  $F < 1$ . **Panel B:** Interaction Prime type\* Target type  $F(1, 15) = 6.24 ; p < .05$  (a) For Noisy target, significant principal effect of Prime type,  $F(1, 15) = 6.24, p < .05$ . (b) For Silent Target,  $F < 1$ . Results reproduced from experiment 1 Brunel *et al.*, 2010. Notes. Sd Prime: prime shapes that were presented with sound during learning phase; Nsd Prime: prime shapes that were presented without sound. Errors bars represent standard errors.

We interpreted these results as evidence that the component reactivated by both the prime and the target has the same nature (*i. e.*, perceptual). Consequently, our results provide a strong argument in favor of the idea that access to conceptual knowledge is linked to the reactivation of the component dimension integrated within a concept (see Barsalou, 2008; Vallet, Brunel & Versace, 2010) which is consistent with a grounded view of cognition. In that case, we can consider that an opposition between modal and amodal form of knowledge is not appropriate for understanding phenomenological distinctions between forms of knowledge. This issue will be discussed in the next section.

## 4 Discussion

The aim of this paper was to propose experimental evidences in a favor of a horizontal view concerning the relation between memory and perception. In that view, perception and memory act simultaneously on the same processing units that are perceptual in nature. Indeed, our studies clearly show that the activation of an auditory memory component (a component that is not perceptually present) is able to influence the sensory processing of a sound or conceptual processing of a typically “sound” concept presented later. In that case, we have to consider that memory knowledge are necessarily sensory-based which is totally consistent with a grounded view of cognition (see Barsalou, 2008). So far we can say that: 1) memory keeps episodic traces from perceptual events; 2) memory traces integrate perceptual components; 3) the components of a given memory trace keep their perceptual characteristics; 4) once a component is activated, this activation is able to spread to the others and influenced the ongoing processing irrespective the cognitive activity.

However there are remaining issues that we don't really address in that paper. The first concerns the type of processing units (*i. e.*, exemplars *vs.* features). Indeed, in the experiments reported here, participants have implicitly learned, through a simple categorization task, that a given shape, which varied through a separable dimension (*i. e.* brightness), is systematically presented with a sound and the other not. We interpreted the fact that only visual prime shapes (whatever the shape's brightness), which were presented with sound in the categorization task, influenced the target's processing (sound or picture of typical sound concepts) thanks to an “exemplar based” memory view (Nosofsky, 1991; Logan, 2002). Each exemplar, which was associated with sound, reactivated it previously encoded sound component. However, we can also interpret

our results as an evidence of unitization (Goldstone, 1998) between a psychological feature, namely a geometrical shape (*i. e.* squares or circles) and an auditory feature (a white-sound). According to the unitization mechanism, we can say that the perfect co-occurrence of an auditory feature and visual psychological feature leads to the creation of a new functional feature combining these two features (Schyns, Goldstone & Thibaut, 1998).

In a recent works (Brunel, Vallet, Riou, & Versace, 2009; see also, Brunel, Goldstone, Vallet, Riou & Versace, 2013), we tried to experimentally settle between these conceptions of memory storage<sup>2</sup>. Basically, we used the same experimental design (learning phase followed by a priming phase with target tones) as Brunel, Labeye and collaborators (2009) experiment. Yet, we manipulated two imperfect rules of category learning sound-shape frequency association (High vs. Low) in learning phase (see Figure 5).

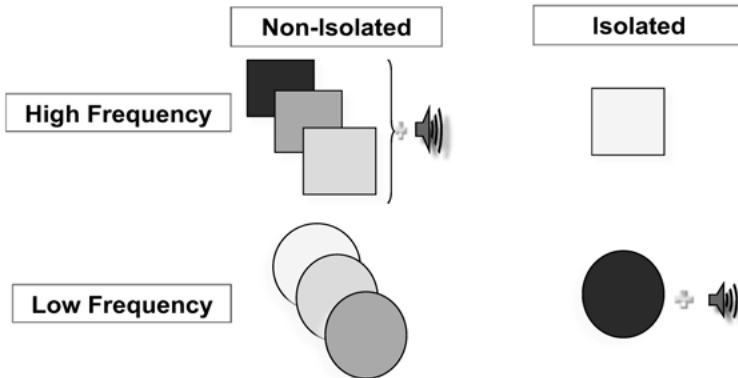

Figure 5: Stimuli used in Brunel, Vallet, Riou & Versace (2009) shape categorization task (learning phase). In this example, for the high frequency condition, three squares (“non-isolated”) were presented simultaneously with a white noise, whereas one (“isolated”) was presented without sound. Following the same example, in the low frequency condition, one circle (“isolated”) was presented simultaneously with a white noise whereas the other three ones were presented alone (“non-isolated”). All the experimental conditions were counterbalanced between-subjects.

For the exemplars seen in High Frequency condition of learning, we observed a generalization effect in the priming phase. The isolated exemplar (which was presented without sound during learning phase) yields same priming effect than exemplars seen with sound in learning phase. So, generalization effect that we observed could be interpreted as a consequence of a multisensory unitization between a visual feature (shape)

<sup>2</sup> According to Goldstone (1998) we refer here at « whole imprinting » and « feature imprinting ».

and an auditory feature (white-noise) that is an argument in favor of “feature imprinting” view of memory. Nevertheless, for the exemplars seen in low frequency condition of learning, we observed a discrimination effect in priming phase. The isolated exemplar presented with sound enhanced the processing of targets tones compared to the exemplars seen without sound during the learning phase. So, discrimination effect that we observed could be interpreted as a consequence of a multisensory integration between visual features (shape and level of brightness) and an auditory feature (white-noise) that is an argument in favor of “whole imprinting” view of memory. Taking together, these results suggest existence of multiple levels of representation (i. e., feature and exemplar, see Navarro & Lee, 2002), or multiple levels of processing (i. e., dimensional and featural), or both, during retrieval.

The second issue is related to the first one but concern the ability of the memory to produce qualitative and distinct forms of knowledge. We proposed that each form of knowledge emerges from the activation and the integration, and the synchronization of multiple memory traces (see also Versace et al., 2009). The difference between episodic and semantic is thus no more qualitative but rather quantitative, *i. e.* in term of number of episodes or traces, which are reactivated. We suggest that information is maintained in memory through a hierarchical multimodal memory integration mechanism. We consider that this mechanism, as presented in Figure 6, may be of relevance for the expression of the different forms of knowledge (*e. g.*, semantic and episodic) and the various types of memory processing (*i. e.*, categorization, recognition, memory retrieval).

In this model, an object is assumed to be perceived as a unified object because all its features are gradually integrated with one another. However, contrary to the exemplar-based approach, we suggest that what is stored in memory is the result of each integration at each level of LTM. We argue that a competition is involved during feature integration. This competition depends on both the distance between exemplar features within and between categories, and on the frequency of the presentation of the combinations of the different features.

In addition, we suggest that all the levels are not necessarily accessed for the processing of an exemplar in a given task: 1) to categorize an exemplar, it is sufficient to activate the unitized dimension which is relevant for the category; 2) to recognize an item, it is necessary to activate each unitized feature that is relevant for the exemplar.

In conclusion, we propose that each form of knowledge emerge from the dynamics interactions between multisensory units, which are both perceptual and mnemonic in

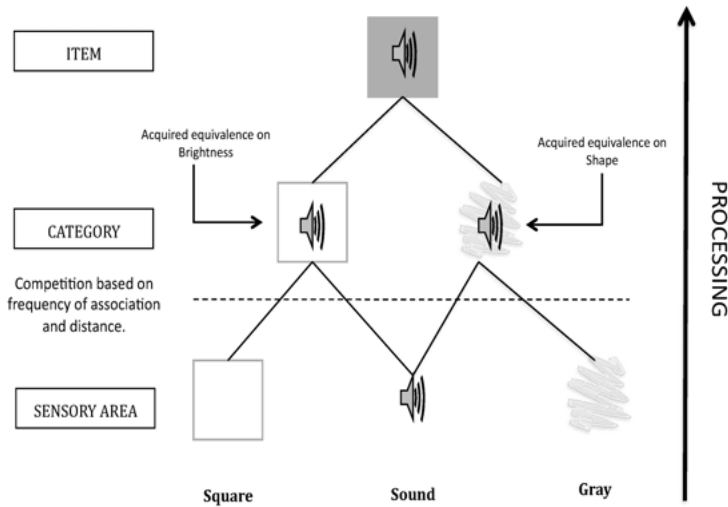

Figure 6: Illustration of multimodal hierarchical integration between features in long-term memory (adapted from Murray & Bussey, 2007).

nature. As a consequence, the distinction between memory and perception might be only at phenomenological level. In other words, it is the subjective attribution (whether to a component perceptually present or absent) to the cognitive activity that would determine the nature of this activity.

## References

- Barsalou, L. W. (2005). Abstraction as dynamic interpretation in perceptual symbol systems. In L. Gershkoff-Stowe & D. Rakison (Eds.), *Building object categories* (389–431). Carnegie Symposium Series. Mahwah, NJ: Erlbaum.
- Barsalou, L. W. (2008). Grounded Cognition. *Annual Review of Psychology*, 59, 617–645.
- Barsalou, L. W., Simmons, W. K., Barbey, A., & Wilson, C. D. (2003). Grounding conceptual knowledge in modality-specific systems. *Trends in Cognitive Sciences*, 7, 84–91.
- Brunel, L., Labeye, E., Lesourd, M., & Versace, R. (2009). The sensory nature of episodic memory: Sensory priming due to memory trace activation. *Journal of Experimental Psychology: Learning, Memory and Cognition*, 35, 1081–1088. doi: 10.1037/a0015537.
- Brunel, L., Lesourd, M., Labeye, E., & Versace, R. (2010). The sensory nature of knowledge: Sensory priming effect in semantic categorization. *The Quarterly Journal of Experimental Psychology*, 63, 955–964. doi: 10.1080/17470210903134369.

- Brunel, L., Goldstone, R. L., Vallet, G., Riou, B., & Versace, R. (2013). When seeing a dog activates the bark: multisensory generalization and distinctiveness effects. *Experimental Psychology*, 60, 100–112. doi: 10.1027/1618-3169/a000176.
- Brunel, L., Vallet, G., Riou, B. & Versace, R. (2009). The sensory nature of knowledge : Generalization vs. specification mechanisms. In N.A. Taatgen & H. van Rijn (Eds.), *Proceedings of the 31st Annual Conference of the Cognitive Science Society* (pp. 2789–2794). Cognitive Science Society.
- Delvenne, J.-F., Cleeremans, A., & Laloyaux, C. (2009). Feature bindings are maintained in visual short-term memory without sustained focused attention. *Experimental Psychology*, 57, 108–116. doi: 10.1027/1618-3169/a000014.
- Fort, A., & Giard-Steiner, M. H. (2002, April). Does attention influence audio-visual neural interactions during bimodal object recognition?. In *Cognitive Neuroscience* (pp. 68–68). five cambridge center, cambridge, ma 02142 usa: mit press.
- Giard, M. H., Peronnet, F. (1999). Auditory-visual integration during multimodal object recognition in humans: a behaviour and electrophysiological study. *Cognitive Neuroscience* 11 (5), 473–490.
- Goldstone, R. L. (1998). Perceptual learning. *Annual Review of Psychology*, 49, 585–612.
- Hall, G. (1991). Perceptual and Associative Learning. Oxford psychology series. New York, NY : Clarendon Press / Oxford University Press.
- Hommel, B. (1998). Event files: Evidence for automatic integration of stimulus-response episodes. *Visual Cognition*, 5 (1/2), 183–216.
- Humphreys, G. W., & Riddoch, M. (1987). Visual object processing: A cognitive neuropsychological approach. In *European International Neuropsychology Society Conference, Jun, 1984, Aachen, Germany*. Lawrence Erlbaum Associates, Inc.
- King, A. J., Calvert G. A. (2001). Multisensory integration: perceptual grouping by eye and ear. *Current Biology*, 11 (8), 322–325.
- King, A. J. (2005). Multisensory integration : strategies for synchronization. *Current Biology*, 15 (9), 339–341.
- Labeye, E., Oker, A., Badard, G., & Versace, R. (2008). Activation and integration of motor components in a short-term priming paradigm. *Acta Psychologica*, 129 (1), 108–111.
- Lehmann, S. & Murray, M. M. (2005). The role of multisensory memories in unisensory object discrimination. *Cognitive Brain Research*, 24, 326–334.

- Labeye, E., Oker, A., Badard, G., & Versace, R. (2008). Activation and integration of motor components in a short-term priming paradigm. *Acta Psychologica*, 129, 108–111. doi: 10.1016/j.actpsy.2008.04.010.
- Logan, G. D. (2002). An Instance Theory of Attention and Memory. *Psychological Review*, 109, 376–400.
- Martin, A., Ungerleider, L. G., & Haxby, J. V. (2000). Category specificity in the Brain: The Sensory/ Motor Model of semantic representations of objects. In M. Gazzaniga (Ed.), *The Cognitive Neurosciences* (pp. 839–847). Cambridge, MA: The MIT Press.
- Meyer, M., Baumann, S., Marchina, S., & Jancke, L. (2007). Hemodynamic responses in human multisensory and auditory association cortex to purely visual stimulation. *BMC Neuroscience*, 8 (14).
- McGurk, H., & Mac Donald, J. W. (1976, November 4). Hearing lips and seen voices. *Nature*, 264, 746–748.
- Murray, E. A., Bussey, T. J. & L. M. (2007). Visual Perception and Memory: A new view of temporal lobe function in Primates and Rodents. *Annual Review of Neurosciences*, 30, 99–122.
- Navarro, D. J., & Lee, M. D. (2002). Combining dimensions and features in similarity-based representations. *Advances in neural information processing systems 15: proceedings of the 2002 conference / Suzanna Becker, Sebastian Thrun and Klaus Obermayer (Eds.): pp. 67–74.*
- Nosofsky, R. M. (1991). Test of an exemplar Model for relating perceptual classification and recognition memory. *Experimental Psychology: human, perception and performance*, 17, 3–27.
- Nyberg, L., Habib, R., McIntosh, A. R., & Tulving, E. (2000). Reactivation of encoding-related brain activity during memory retrieval. *PNAS*, 97 (20), 11120–11124.
- Pecher, D., Zeelenberg, R., Barsalou, L. W. (2004). Sensorimotor simulations underlie conceptual representations: Modality-specific effects of prior activation. *Psychonomic Bulletin & Review*, 11, 164–167.
- Richter, T., & Zwaan, R. (2010). Integration of perceptual information in word access. *The Quarterly Journal of Experimental Psychology*, 63, 81–107. doi: 10.1080/17470210902829563.
- Riou, B., Lesourd, M. Brunel, L., & Versace, R. (2011). Visual memory and visual perception: when memory improves visual search. *Memory and Cognition*, 39, 1094–1102.

- Schmidt, J. R., De Houwer, J. & Besner, D. (2010). Contingency learning and unlearning in the blink of an eye: A resource dependent process. *Consciousness & Cognition*, 19, 235–250. doi: 10.1016/j.concog.2009.12.016.
- Schmidt, J. R., & De Houwer, J. (2012). Contingency learning with evaluative stimuli. *Experimental Psychology*, 59, 175–182. doi: 10.1027/1618-3169/a000141.
- Schyns, P. G., Goldstone, R. L. & Thibaut, J-P. (1998). The development of features in object concepts. *Behavioral and Brain Sciences*, 21, 1–54.
- Shimamura, A. P. & Wickens, T. D. (2009). Superadditive memory strength for item and source recognition: the role of hierarchical relational binding in the medial temporal lobe. *Psychological Review*, 116 (1), 1–19.
- Shimojo, S., & Shams, L. (2001). Sensory modalities are not separate modalities: plasticity and interactions. *Current Opinion in Neurobiology*, 11, 505–509.
- Slotnick, S. D. (2004). Visual memory and visual perception recruit common neural substrates. *Behavioral and Cognitive Neuroscience Review*, 3, 207–221.
- Teder-Sälejärvi, W. A., Di Russo, F., McDonald, J. J., & Hillyard, S. A. (2005). Effects of Spatial Congruity on Audio-Visual Multimodal Integration. *Cognitive Neuroscience*, 17 (9), 1396–1409.
- Tulving, E. (1995). Organisation of Memory: Quo Vadis? In M. Gazzaniga (Ed.), *The Cognitive Neurosciences*, (pp. 839–847), Cambridge, MA: The MIT Press.
- Van Dantzig, S., Pecher, D., Zeelenberg, R., & Barsalou, L. W. (2008). Perceptual processing affects conceptual processing. *Cognitive Science*, 32, 579–590. doi: 10.1080/03640210802035365.
- Vallet, G., Brunel, L. & Versace, R. (2010). The Perceptual Nature of the Cross-modal Priming: Arguments in Favour of Sensory-Based Memory Conception. *Experimental Psychology*, 57, 376–382
- Versace, R., Labeye, E., Badard, G., & Rose, M. (2009). The content of the long term memory and the emergence of the knowledge. *European Journal of Cognitive Psychology*, 21 (4), 522–560.



MARTIN V. BUTZ AND DANIEL ZÖLLNER

## Towards Grounding Compositional Concept Structures in Self-organizing Neural Encodings

Martin V. Butz  
University of Tübingen, Faculty of Science,  
Department of Computer Science,  
Cognitive Modeling

[martin.butz@uni-tuebingen.de](mailto:martin.butz@uni-tuebingen.de)

Daniel Zöllner  
University of Tübingen, Faculty of Science,  
Department of Computer Science,  
Cognitive Modeling

[daniel.zoellner@gmx.net](mailto:daniel.zoellner@gmx.net)

### Abstract

While the symbol grounding problem of agreeing on a mapping between symbols and sensory or even sensorimotor grounded concepts has been solved to a large extent, one possibly even deeper open problem remains: How do concepts and compositional concept structures develop in the first place? Concepts may be described as integrative mental representations that encode certain sensory, motor, or sensorimotor states or events. Compositionality, on the other hand, determines how concepts are associated with each other in a semantically meaningful and highly flexible manner. We argue that progressively complex concepts and compositional structures can be developed starting from very basic perceptual and motor control mechanisms. An experiment with a simple simulated robot gives hints about highly relevant structural ontogenetic prerequisites for their development. In the outlook, we conclude by sketching out the current most pressing challenges ahead.

Keywords: concepts, compositionality, development, symbol grounding, language, neural networks, manifolds, anticipation

## 1 Introduction

Symbols are “placeholders” standing for other entities. In a dictionary, and often in conversation, symbols are explained through other symbols. This is a potentially endless process called “semiosis” by the philosopher Charles Sanders Peirce: Symbols are described by symbols, which are described by symbols – and so on. But how can this endless process be ultimately grounded, how “is symbol meaning to be grounded in something other than just more meaningless symbols?” (Harnad 1990, p. 340). This is what Harnad (1990) calls the “symbol grounding problem”.

While Steels (2008) states that the basic symbol grounding problem has been solved, it was also pointed out that yet a deeper symbol grounding problem needs to be addressed (cf. Barsalou 2009, Harnard 1990, Sugita & Butz 2011). The robotic agents in Steels' works are able to come to an agreement about a symbol convention for particular communication realms (such as gestures, colors, etc.). That is, a common language is developed where particular symbols or utterances are associated with particular perceptions or perception-action complexes. The challenge of the deeper symbol grounding problem lies in the development (a) of compositional concept structures from sensorimotor control capabilities and (b) of associations between those structures and grammatical, symbolic, i. e. linguistic structures. Only when these two challenges are accomplished, formal semantics may be actually grounded in sensorimotor codes.

The study of both the developmental progression that led to the grounding of compositional concepts and the nature of the involved structures and associations is expected to provide insights on how "Cognitive Semantics" (Johnson 1987, Lakoff 1987, Lakoff & Johnson 1980) actually pre-determine formal semantics and most likely even structural properties of the universal grammar (Chomsky 1965). Most recently, the idea of cognitive semantics led to the proposition of a Minimalist Action Grammar (Pastra & Aloimonos 2012), which was directly related to the Minimalist Program by Noam Chomsky (1995). The Minimalist Action Grammar is a generative grammar that enables both proper generation and parsing of sentences about physical interactions. It binds an interaction by its final goal, combining tool complements, which are about the acting force, with object complements, which are about the affected object, context- and goal-dependently.

We are particularly interested in how such a Minimalist Action Grammar may develop starting purely from embodied, sensorimotor interactions – in the hope to contribute to the deeper symbol grounding problem sketched-out above. The aim is to develop a self-motivated system that solely perceives its environment via sensory stimulations and that probes its environment by motor activities, where sensors and motors are coupled by the bodily morphology. Ultimately, such a model may show that many structures present in the Universal Grammar are grounded in sensorimotor interactions with the environment that are realized by an embodied agent. Meanwhile, such a line of research is expected to also shed light on why and how grammatical structures in language are structured in the way they are – hints of which can also be found in the Minimalist Action Grammar.

Various researchers now strongly believe that sensorimotor structures and the selective simulation of particular sub-structures set the stage for the development of compositional concept structures (Barsalou 2008, Grush 2004, Pastra & Aloimonos 2012, Pezzulo 2011). How such structures are developed and how these structures may then be coupled with higher level cognitive, symbolic encodings is still an open question, though. While the claim that the compositionality of language may be grounded in the compositionality inherent in interaction competencies is not new (Johnson 1987, Lakoff 1987), how such grounding may be learned and how compositionality may be represented by means of sub-symbolic structures remains an open question. Arbib (2005) proposed a developmental pathway that leads from interactions, the mirror neuron system, and imitation capabilities over several further stages to linguistic competence. We believe that these stages are important components in the development of concepts and compositional concept structures. However, several other prerequisites appear mandatory.

The aim of this paper is to sketch out a path by means of which complex, compositional concept structures are action-grounded. We propose that in order to explain the human capacity to generalize, to draw inductions, and to develop compositionality, it is not necessary to resort to innate structures. Rather, as increasingly many robotic architectures and even more so simulations with neural networks imply, compositional concept structures can be developed by a brain “from scratch”, departing from sensorimotor contingencies. Endorsing the “Cognitive Semantics” of Lakoff and Johnson (1980), we propose to make the next step to confirm this theory by identifying the ontogenetic ingredients that appear necessary to develop such semantics. Thus, we are interested in the architectural constraints and learning biases necessary for developing compositionality based on sensorimotor interactions.

In this way, the paper also takes a stand in the nature/nurture-debate about concepts. In particular we propose that structures, which rationalists tend to regard as purely innate, are actually derivatives of sensorimotor experiences and developmental constraints. Thus, we propose a nature-constraint “nurture” process, in which genetically determined bodily and brain developmental constraints stream cognitive development towards the acquisition of compositional concept structures and language readiness. However, only with the additionally necessary environmental interactions including linguistic communication can the language capacity develop. Consequently, concepts are grounded in the experienced interactions, but genetic predispositions bias the cognitive developmental process towards concept acquisitions.

We argue that purely innate structures leave no flexibility and are generally extremely questionable due to the immense depth of the necessary structures and due to the fact that even innateness needs to be somehow couple such structures to perceptions and actions. Thus, a core claim of this paper is that the Symbol Grounding Problem (Harnad 1990) can only be solved by an empiricist approach to concept acquisition. In contrast to Fodor's (1975, 2008) radical claim that concepts cannot be learned, we suggest that a theory of concept learning is essential for a complete theory of cognition and the mind.

In the following, we first detail a neural network architecture with which it has recently been shown that representational separations and multiplicative interactions between modules are essential ingredients for the development of compositional concept structures. We detail the type of compositional structures that were developed and how thus compositionality was grounded in embodied sensorimotor interactions. We discuss the implications of this study, but also its limitations and current most pressing challenges. Finally, we put the insights gained into the broader perspective on how concepts and compositionality may develop.

## 2 An Experiment with a Simulated Robot Platform

In a neural network simulation setup, it was shown that a second-order neural network with parametric bias neurons (sNNPB) is able to develop generalized behavioral control routines, presenting the system solely with typical sensory-motor time series data (Sugita, Tani, & Butz 2011). This study essentially offers tentative answers to the question: How can compositional concept structures self-organize based on experienced sensorimotor interactions? Additional ingredients will be necessary to scale this approach to more complex environments and interaction capabilities.

In the experiment, a simulated robot interacted with colored objects. The robot was equipped with two wheels for controlling motion and a camera that scanned the surrounding in front of the robot. In particular, the camera reported the perceived dominant hue and color intensity values covering an area of  $120^\circ$  in front of the robot. The covered areas were partitioned into nine equally spaced sectors. The robot learned two types of interactions: *move-to* and *orient-towards* a particularly *colored object*. In the *move-to* interaction, the robot had to move to the object and stop in front of it. In the *orient-towards* interaction, the robot had to simply orient itself towards an object at a specific angular offset; five offsets were trained. One or two colored objects were

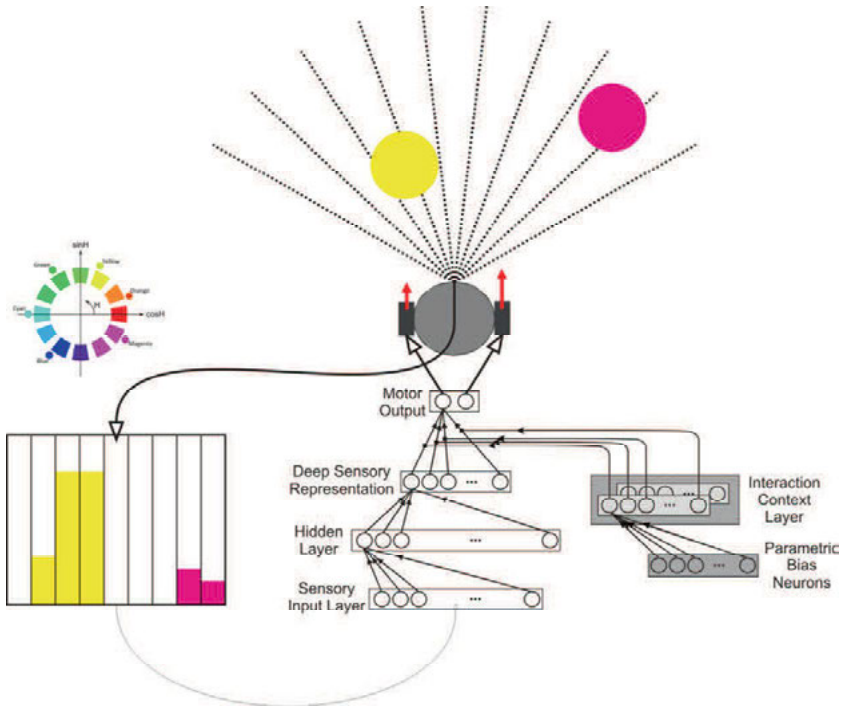

Figure 1: Robot-Environment-sNNPB interaction

present during each interaction trial with the environment. During learning, the actions of the robot were controlled remotely by a hard-coded control program. Figure 1 illustrates the robot, environment, sNNPB interaction.

In the following, we will refer to the two types of interactions as the “verbs” that were trained, to the different colored objects as the “objects” that were addressed in the interactions, and to the offsets in the orient-towards interactions as the involved “modifiers”. Note however that the learning system was not provided with any explicit indicators – neither about the “verbs” nor about the “objects” or the “modifiers” – that may have given clues or induced learning biases towards distinguishing “verb”, “object”, and “modifier” concepts. The only information given to the learning system was the sensorimotor time series data the robot was trained on and the information that particular sets of sensorimotor time series data belonged to the same type of interaction.

The resulting sensorimotor time series data was used to train an sNNPB. An sNN is a traditional neural network, which is trained with backpropagation, which, however,

includes some “second-order” neural connections. Second order neural connections essentially are connections whose current weight values are determined by other neural activities. In the conducted simulations, one sub-NN mapped the visual information provided by the camera onto motor output transferring the information over two hidden layers. The connection weights of the connections from the second hidden layer to the motor output, however, were determined by second-order connections. The associated neurons were activated by a second sub-NN with one hidden layer. Input to this network was generated by “parametric bias neurons” (Tani 2003). Error backpropagation was used to adjust the weights of the sNNPB as well as the activities of the parametric bias neurons. The latter were adjusted interaction-specific, thus maintaining a vector for each type of verb-object-modifier interaction the system was trained on.

After learning, the sNNPB was tested on other object constellations and on other, untrained verb-object-modifier interactions. For example, the sNNPB may have never been trained on “move-to the blue object”. Nonetheless, after learning the system was tested if it can generate such interactions. To do so, the activity of the parametric bias neurons was set to activity values that matched a small set of generated interactions best. After that, other constellations were tested applying these PB activities.

The results confirmed that the sNNPB generalized over the provided sensorimotor time series data. It was not only able to generate similar interactions in other environmental constellations, but also to generate interactions that were only compositionally related to those trained on. For example, it was able to orient itself towards a particular colored object at a particular angle, while it only had been trained to move to such a colored object. Thus, behaviorally the network exhibited generalization capabilities that were of a compositional nature. Interactions that corresponded to verb-object-modifier constellations could be generated that were not trained – as long as a sufficiently large and distributed subset of other interactions was trained.

Moreover, analyses of the developed sNNPB showed that a self-organized geometrically-arranged manifold structure had developed, which reflected the behaviorally exhibited compositionality. In particular, the activity vectors of the parametric bias neurons were considered for further analysis. A principal component analysis showed that the first principal component differentiated the interactions with respect to the modifier. The second principal component differentiated move-to from orient-towards. The third and fourth principal component revealed a color ring encoding, akin to the one found in the hue-based color encoding provided to the sensory input layer. Thus, activities

in the parametric bias neurons self-organized via backpropagation learning into a compositional manifold structure, where the individual dimensions in the manifold corresponded to the verb, object, and modifier components of the individual interactions. The manifold structure enables the sNNPB to flexibly activate any meaningful verb-object-modifier interaction type and also allows generalizing to untrained interaction types. The geometric, orthogonal arrangement was akin to a compositional concept structure because the orthogonality enables flexible interaction concept combinations and the deducible geometric distances can be viewed as indicating concept similarities.

Interestingly, also the structure of the second hidden layer – the one that maps to motor output via the second-order neural connections – was analyzed. Strongly behavior-oriented sensory encodings were found. For example, one neuron switched its behavior from off to on when an object is in the center and very close – resulting in breaking behavior when the move-to interaction is activated in the parametric bias neurons. Other neural activities revealed activities that may be compared to gain fields in neurons (Salinas & Sejnowski 2001, Graziano 2006): neurons responded, for example, in a sinusoidal fashion with respect to color but that response was linearly modulated by the direction where the color was perceived from. In effect, this encoding allowed the flexible activation of particular color-respective encodings for approaching and orienting the robot towards particular colors, dependent on the activated mapping given particular parametric bias activity. From a broader perspective it can be said that object-relative encodings developed that encoded “object affordances” (according to Gibson 1979), in the sense that the encodings afforded to reach a particular orientation towards a particular object or to stop moving when coming close to an object. Providing yet another interpretation, spatial, object-relative encodings were developed that could be directly mapped towards motor activities, yielding a flexible Braitenberg vehicle (Braitenberg 1984).

The network succeeded in developing these compositional concept structures without the provision of any semantic cues besides the ones that were inherent in the sensorimotor time series data. Seeing that various other neural network architectures could not yield similar generalizations, it was concluded that (a) goal-oriented encodings need to be separated from sensorimotor, control-oriented encodings and (b) a multiplicative approach is best-suited to project the goal-oriented encodings onto the sensorimotor encodings for realizing flexible and compositional goal-oriented behavioral control. In the emergent, interaction-specific, goal-oriented encodings the mentioned compositional concept structures could be found, whereas in the processed sensory encodings

behavior-oriented signals could be found. Both were shown to be mutually dependent on each other – the former selecting the actual interaction that should be executed; the latter providing potential interaction options.

Seeing that various other neural network architectures were not able to generate comparable compositional behavioral generalization capabilities – let alone actual identifiable compositional structures as the one characterized above – the results suggests that sensory-to-motor mappings should be separated from interaction selection encodings to enable the development of compositional concept structures. Essentially, the interaction selection corresponds to the goal that is to be achieved, with considerations of the component that bring each particular goal about – such as moving to a particularly colored object. While various researchers have suggested that such separations are behaviorally necessary (Cisek 2007), we believe they have not been sufficiently considered in research on the development and structure of language and cognition.

### **3 Insights and Open Challenges Deducible from the Robot Experiment**

The results of the simulated robot experiment have shown that compositional concept structures could only develop in this setup when the sensory-to-motor mapping was separated from the goal encoding, that is, from the code that determines which sensory-to-motor interaction should actually unfold. Also, the time dynamics had to be different in the two encodings in that one goal activity had to be maintained while one full sensorimotor object interaction unfolded. Moreover, it was necessary that the influence from the goal encoding onto the sensory-to-motor mapping was multiplicative. Finally, the generated sensorimotor time series data had to be separated into distinct sets with respect to particular verb-object-modifier combinations. However, no information about the semantics or symbolic characterizations of these particular combinations had to be provided.

In consequence sensorimotor grounded compositional concept structures and behavior-oriented “Braitenberg encodings” co-developed, that is, encodings which are perfectly suited to be directly mapped onto motor output activities, yielding seemingly goal-directed behavior (Braitenberg 1984). Braitenberg encodings are thus goal-oriented encodings, which can be selectively mapped onto actions for pursuing particular object interactions. Indeed, the compositional concept structures had structural similarities with the emerging Braitenberg encodings, thus enabling the selective activation



of particular Braitenberg codes for realizing particular object interactions. Compositionality was achieved by embedding a manifold structure into a higher-dimensional neural representation. The individual dimensions of the lower-dimensional (in the experiment four dimensional) manifold corresponded to the compositional verb-object-modifier structure. The developed “object” concept was encoded on a two-dimensional manifold (actually a circular manifold), mimicking the hue-based color encoding in the simulated sensors. Due to the emerging orthogonal arrangement of the distinct concept structures, the sNNPB was able to flexibly compose any verb-object-modifier interaction, even if it had not been trained. The developed compositional concept structure appeared to be perfectly suited to be associated with a corresponding action grammar.

However, at this point language structures have not been successfully associated with developing compositional structures, yet. Sugita & Tani (2005) managed to associate symbolic structures with similar sensorimotor time series data. However, in this case only a more rudimentary action grammar consisting of three possible verbs and six possible colors was learned. Nonetheless, Sugita and Tani (2005) succeeded in mutually shaping both the symbol-based linguistic encoding and the sensory-to-motor mapping. Thus, associating symbolic, linguistic input with developing, self-organizing, more complex action grammars is still a very hard challenge.

Even when focusing only on the challenge of developing pre-linguistic compositional concept structures – without associating symbolic language components – however, additional learning biases and developmental constraints seem mandatory for scalability reasons. At the moment, the sNNPB architecture is still an extremely flexible learning architecture. For developing more complex compositional structures, it seems necessary that the learning processes are further guided by additional learning biases. However, overly constraint learning may not give enough room for the emergence of compositional concept structures, such as the manifold structure identified in the robot experiment. Thus, complex compositionality is likely to emerge only if a good balance between learning biases on the one hand and self-organization on the other hand is maintained.

Another challenge lies in the fact that sets of sensorimotor time series data had to be explicitly distinguished when training the sNNPB, while the more autonomous separation of different types of interactions is desirable. While similarity thresholds may distinguish the sensorimotor time series data, it is very hard to find the right distance metric that could suitably distinguish different time series in a semantically meaningful way. The self-organized topology in the PB neurons of the sNNPB is likely

to be the best candidate, but the development of it relied on the distinctness information in the first place.

We believe that several of the following ingredients will be mandatory to develop learning systems that can autonomously produce emergent compositional concept structures in more complex environments. First, the incorporation of an *anticipatory drive* (Butz 2008) that stresses the capability of predicting the future based on state, context, and motor (force) activities seems necessary. Such an anticipatory drive may guide learning first towards identifying the most obvious sensorimotor contingencies in the sensory and motor information available to the system. Further distinctions starting from basic sensorimotor flow may then lead to the desired progressively more distinct compositional concept structures.

Once sensorimotor contingencies are identified, sensorimotor topologies can be developed within which particular interactions can unfold. In the simulated robot experiment, a topology was implicitly developed in the deep sensory encodings, providing Braitenberg codes. Similar, but further modularized encodings are necessary to enable the even more flexible and selective interaction with the environment using different means, different pathways through the environment, etc.

Furthermore, active, information-seeking, curious behavior, caused by the anticipatory drive, may enable the more direct identification of relevant concept structures, that is, of sensory and motor information necessary for predicting particular consequences reliably. The consequent identification of contextual “concepts” that separate states into concepts that are relevant for particular behaviors – such as free versus occupied, heavy versus light, etc. – will be the result.

Besides these learning biases derived from the anticipatory drive, the challenge of removing the requirement of providing distinct sets of sensorimotor time series data may be accomplished by introducing internal motivations. Such internal motivations may serve as the distinctness indicators – identifying a distinct interaction by its distinct effect on the internal motivational state. Thus, distinct positive and negative reinforcement may serve as a critical additional clue to distinguish interactions further into meaningful concepts.

Finally, it seems somewhat unsatisfactory that the activity in the parametric bias neurons cannot be internally self-activated. To do so, the activity of the parametric bias neurons may be partially activated by sensory input as well – potentially enabling the selective activation of those interaction codes that can actually unfold in the current circumstances. For example, a potential interaction with a red object may only be

activated if a red object is present. Furthermore, the mentioned internal motivations may be associated with those parametric bias neuron activities that previously had led to a corresponding change in the internal motivational state. Consequently, the interaction choice may be co-determined by the internal motivations and the goals currently possible in the environment.

## **4 Conclusions**

The robot experiment described above contributes to the solution of the symbol grounding problem, and also illuminates concept learning. One of the most vexing problems regarding this topic is Fodor's problem of concept acquisition. Fodor (1975, 2008) essentially questions that fundamental concepts – those that cannot be further partitioned into smaller conceptual entities – can be learned. And presuming that they cannot be learned, he concludes that they must be innate. The details of Fodor's argument are beyond the scope of this article. It suffices to state that according to most recent philosophical considerations, "it appears that Fodor's problem of concept acquisition remains a puzzle for philosophers and psychologists to solve" (McCaffrey & Machery 2012, p. 275).

We propose to overcome Fodor's "radical concept nativism" (cf. Laurence & Margolis 2002) by a different stance towards "innateness". This very ambiguous term may gain a more specific sense if it is related to embodiment. In short, we propose that the innateness of concepts may not be directly genetically imprinted, but concepts and compositional concept structures may be indirectly pre-determined to develop due to (a) the ontogenetic path laid-out in the genes of the organism, (b) the morphological constraints given by the body of the organism, and (c) the environmental reality with which the organism interacts.

Fundamental concepts may indeed be innate – but actually innate in the sense of being behaviorally embodied and pre-destined to be developed. For example, basic reflexes – such as the grasp reflex in infants – can foster the development of particular concepts – such as a concept for grasping. Separating then successful from unsuccessful grasps, a concept structure that specifies the prerequisites for a successful grasp develops, in contrast to contexts where grasps are unsuccessful. Co-developing with such a representation is a concept of graspable entities. Realizing the effects of successful grasps, will expand and differentiate the grasp concept further into entities that are moveable, light versus heavy, spiky versus smooth, etc. The basic reflex may thus lead to the gener-

ation of sensorimotor interactions that can be differentiated on the one hand side by their perceptual differences but, and even more importantly so, by their distinct effects.

Essentially we point-out that the combination of an anticipatory drive with an embodied, sensing and acting agent can foster the development of pre-linguistic, compositional concept structures. The anticipatory drive drives the organism to actively search for and learn about predictable and controllable (sensorimotor) structures in the environment (Butz 2008). Due to this self-controlled, embodied developmental process, the developing concept structures are inherently meaningful because the structures determine predictability, controllability, and their relation to changes in internal motivational states. Thus, the combination of the human body morphology with its ontogenetic development of body and brain fosters the development of “innate” but behaviorally acquired compositional concept structures.

Unitizations and differentiations in the sense of Landy & Goldstone (2005) (cf. also Stöckle-Schobel 2012) are fundamental processes that foster the development of compositional concept structures. We propose that these processes are not purely perceptual or sensorimotor, but are developed for predictability, controllability, and achievability purposes. With this proposition we go one step beyond theorists of “neo-empiricism” like Barsalou (2009), Jesse Prinz (2002), and others. We strongly acknowledge that their accounts on perceptually grounded symbols and concepts are highly important in overcoming unworkable accounts of innateness. However, we would like to further stress that cognition and – more specifically, concept acquisition – is not solely shaped by (and for) perception. Rather, it is most important for being able to interact flexibly goal-directedly with objects and other agents.

Moreover, the robot experiment has shown that spatial, object- and body-relative representations should be separated from goal-oriented representations in order to foster the development of compositional structures. Given this separation, particularly the goal-oriented representations appear well-suited for the development of compositionality. Thus, the separation of dorsal and ventral pathway (Goodale & Milner 1992), which is certainly highly behaviorally relevant and mandatory for realizing flexible behavioral control (Cisek 2007, Milner & Goodale 2008), may have actually set the stage for the development of compositional concept structures, that is, structures that allow the development of language in the first place.

Certainly other processes are still highly important as well. In particular, we believe that the development of mirror capabilities and tool use are two fundamental additional ingredients. The capability of mirror neurons, which was first most likely beneficial for

improving mutually beneficial interactions with other individuals, fosters the further development of communication between individuals, by, for example, enabling the development of verbal imitations from gestural imitations (Arbib 2005, Rizzolatti & Arbib 1998). The capability of handling tools led to the development of much more intense interactions between the dorsal and ventral processing streams, thus being able to view tools and objects as part of the subject and, in retrospect, also oneself as a tool (Iriki 2006).

However, we believe that the sketched-out processes will set the stage to be able to ultimately solve the mystery of concept acquisition. By separating goals from spatial topologies and events, flexible goal-directed behavior can be selected and pursued. Current internal goals can be flexibly pursued dependent on the current spatial constraints. Moreover, the availability of potential goals in the environment as well as the context-dependent estimated achievability of such potential goals can yield tremendous behavioral flexibility and effectivity. While the development of such a separation was thus initially most likely purely behavior-driven, it also enabled the development of compositional concept structures. While potential goals and the involved concepts for achieving these goals are detached from the here-and-now, the encodings can be flexibly projected onto the current state in the environment. Meanwhile, state representations must have developed that enable the flexible activation of goals and involved concepts for pursuing particular goals. Object-referenced encodings found in the parietal cortex (Chafee, Averbeck, & Crowe 2007) support the pro-motor representations found in integrative, multimodal cortical areas. The parietal-frontal interactions with which action goals appear to be transferred into actual movement control support their strong goal- and behavioral relevance (Graziano, Cooke 2008). Arguably, similar correspondences were even proposed to exist between Wernicke's and Broca's areas (Graziano, Cooke 2008). Finally, gain-modulations, which are found nearly ubiquitously in the brain, suggest selective, multiplicative computations in individual neurons (Salinas & Sejnowski 2001), supporting the flexible, goal-oriented selection of maximally suitable sensory-to-motor mappings.

In the minimalist Action Grammar as proposed by Pastra & Aloimonos (2012) goals unify particular actions with objects and further modifiers. Our proposition in this paper gives first hints why goals are crucial both, for the development of grammatical structures and for being able to flexibly combine compositional concept structures to achieve particular goals dependent on their current urgency and achievability. Nonetheless, much future research is necessary to sort the identified puzzle pieces, identify even

further pieces, and arrange them in the way the ontogenesis of the brain manages to do so beautifully.

## References

- Arbib, M. A. (2005). From monkey-like action recognition to human language: An evolutionary framework for neurolinguistics. *Behavioral and Brain Sciences*, 28, 105–167.
- Barsalou, L. W. (2008). Grounded cognition. *Annual Review of Psychology*, 59, 617–645.
- Barsalou, L. W. (2009). Simulation, situated conceptualization, and prediction. *Philosophical Transactions of the Royal Society B: Biological Sciences*, 364, 1281–1289.
- Braitenberg, V. (1984). *Vehicles: Experiments in synthetic psychology*. Cambridge, MA: MIT Press.
- Butz, M. V. (2008). How and why the brain lays the foundations for a conscious self. *Constructivist Foundations*, 4, 1–42.
- Cangelosi, A., & Riga, T. (2006). An embodied model for sensorimotor grounding and grounding transfer: Experiments with epigenetic robots. *Cognitive Science*, 30, 673–689.
- Chafee, M. V., Averbeck, B. B., & Crowe, D. A. (2007). Representing spatial relationships in posterior parietal cortex: Single neurons code object-referenced position. *Cerebral Cortex*, 17, 2914–2932.
- Chomsky, N. (1965). *Aspects of the theory of syntax*. Cambridge, MA: MIT Press.
- Chomsky, N. (1995). *The minimalist program*. Cambridge, MA: MIT Press.
- Cisek, P. (2007). Cortical mechanisms of action selection: The affordance competition hypothesis. *Philosophical Transactions of the Royal Society B: Biological Sciences*, 362, 1585–1599.
- Fodor, J. (1975). *The Language of Thought*. New York: Crowell.
- Fodor, J. (2008). *LOT 2. The Language of Thought Revisited*. Oxford: Oxford University Press.
- Gibson, J. J. (1979). *The ecological approach to visual perception*. Mahwah, NJ: Lawrence Erlbaum Associates, Inc.
- Goodale, M. A., & Milner, A. D. (1992). Separate visual pathways for perception and action. *Trends in Neurosciences*, 15, 20–25.
- Graziano, M. S. A. (2006). The organization of behavioral repertoire in motor cortex. *Annual Review of Neuroscience*, 29, 105–134.

- Graziano, M. S. A., & Cooke, D. F. (2006). Parieto-frontal interactions, personal space, and defensive behavior. *Neuropsychologia*, 44, 845–859.
- Grush, R. (2004). The emulation theory of representation: Motor control, imagery, and perception. *Behavioral and Brain Sciences*, 27, 377–396.
- Harnad, S. (1990). The symbol grounding problem. *Physica D: Nonlinear Phenomena*, 42, 335–346.
- Iriki, A. (2006). The neural origins and implications of imitation, mirror neurons and tool use. *Current Opinion in Neurobiology*, 16, 660–667.
- Johnson, M. (1987). *The body in the mind: The bodily basis of meaning, imagination and reason*. Chicago, IL: University of Chicago Press.
- Lakoff, G. (1987). *Women, fire, and dangerous things: What categories reveal about the mind*. Chicago, IL: University of Chicago Press.
- Lakoff, G., & Johnson, M. (1980). *Metaphors we live by*. Chicago, IL: University of Chicago Press.
- Landy, D., & Goldstone, R. G. (2005). How we learn about things we don't already understand. *Experimental & Theoretical Artificial Intelligence*, 17, 343–369.
- Laurence, S., & Margolis, E. (2002). Radical concept nativism. *Cognition*, 86, 25–55.
- McCaffrey, J., & Machery, E. (2012). Philosophical issues about concepts. *WIREs Cognitive Science*, 3, 265–279.
- Milner, A. D., & Goodale, M. A. (2008). Two visual systems re-viewed. *Neuropsychologia*, 46, 774–785.
- Pastra, K., & Aloimonos, Y. (2012). The minimalist grammar of action. *Philosophical Transactions of the Royal Society B: Biological Sciences*, 367, 103–117.
- Pezzulo, G., & Calvi, G. (2011). Computational explorations of the perceptual symbol system theory. *New Ideas in Psychology*, 29, 275–297.
- Prinz, J. (2002). *Furnishing the mind. Concepts and their perceptual basis*. Cambridge, MA: MIT Press.
- Rizzolatti, G., & Arbib, M. A. (1998). Language within our grasp. *Trends in Neuroscience*, 21, 188–194.
- Salinas, E., & Sejnowski, T. J. (2001). Gain modulation in the central nervous system: Where behavior, neurophysiology, and computation meet. *The Neuroscientist*, 7, 430–440.
- Steels, L. (2008). The symbol grounding problem has been solved. So what's next? In M. de Vega, A. M. Glenberg & A. C. Graesser (Eds.). *Symbols and embodiment: Debates on meaning and cognition* (pp. 223–244). New Haven: Academic Press.

- Stöckle-Schobel, R. (2012). Perceptual learning and feature-based approaches to concepts – a critical discussion. *Frontiers in Psychology*, 3, 93. doi: 10.3389/fpsyg.2012.00093.
- Sugita, Y., & Butz, M. V. (2011). Compositionality and embodiment in harmony. In Oudeyer, P.-Y. (Ed.), *AMD Newsletter, IEEE CIS*, 8, 8–9.
- Sugita, Y., & Tani, J. (2005). Learning semantic combinatoriality from the interaction between linguistic and behavioral processes. *Adaptive Behavior*, 13, 33–52.
- Sugita, Y., Tani, J., & Butz, M. V. (2011). Simultaneously emerging Braitenberg codes and semantic compositionality. *Adaptive Behavior*, 19, 295–316.
- Tani, J. (2003). Learning to generate articulated behavior through the bottom-up and the top-down interaction processes. *Neural Networks*, 16, 11–23.



ALEX TILLAS

## Grounding Cognition: The Role of Language in Thinking<sup>1</sup>

Alex Tillas  
Heinrich-Heine-University Düsseldorf  
Faculty of Philosophy

atillas@phil.hhu.de

### Abstract

In this paper, I investigate the relationship between natural language and thinking. Specifically, I adopt the view that thinking operates, by and large, according to associationistic rules and argue that natural language plays a crucial role in thinking, but not a constitutive one, as many have argued. I propose that the suggested view enjoys significant empirical support, mainly from work done with aphasic subjects. The major challenges that all associationistic views of thinking face are the problems of propositional thinking and compositionality of thought. I briefly suggest how these challenges could be met in the light of the suggested view regarding thought production.

Keywords: Language; Cognition; Associationism; Aphasia; Concept Empiricism

## 1 Introduction

The relationship between language and cognition is a much-debated one and widely varying notions of this relationship have been produced over the last few decades in fields as varied and diverse as psychology, linguistics and philosophy. The main dialectic of this debate is centred on the issue of the significance of natural language in cognition. It is worth clarifying at this point that there is the issue of ‘whether thought happens in language’ and secondly ‘whether the language in which thought happens, if it does, is natural language’. The problem is that certain thinkers, Fodor for instance (see below), answer the first question emphatically ‘yes’ (language of thought), and others with an emphatic ‘no’. As a result, their answer to the question ‘how important is the role of language to thought?’ is potentially ambiguous. In the following, when talking about language I will be referring to natural language unless stated otherwise.

The main strands in this debate can be briefly classified as follows. I start from views that bestow the least significant role to language in the production of thought,

---

<sup>1</sup> This paper is an early draft of Tillas, A. (forthcoming 2015). Language as Grist to the Mill of Cognition. Cognitive Processing.

and continue by examining views that ascribe language a greater role. Grice (1957; 1968; 1969; 1989) treats language as independent to thought and as merely being used to express non-linguistic thoughts. Linguistic communication is seen as primarily a matter of a speaker changing a hearer's mental states, e.g. getting them to form a certain belief, through recognition of the contents of their thoughts. (The hearer recognises the thoughts of the speaker on the basis of the latter's usage of words). Elsewhere, Grice (1982) speculates that language may have evolved in order to facilitate correspondences in psychological states between one creature and another. Proponents of similar views argue for a reductive account of linguistic meaning to thought meaning. In this sense, language is independent from thinking. A second view can be found in Fodor's (1978; 1983; 1987) Language of Thought Hypothesis (LOTH). For Fodor, thinking occurs in an inner sub-personal code which he calls 'Mentalese'. Mentalese is distinct from natural language and hence the role of natural language in thought is also limited. Language is mainly used for expressing the underlying thoughts in public form. Proponents of similar views, at least according to Carruthers (2005), include Chomsky (1988), Levelt (1989) and Pinker (1994), amongst others. Another view is that of Carruthers (1998; 2005; 2008) according to which the language of thought is actually natural language. In this sense, natural language plays a greater role in thinking than merely communicating thoughts from an unconscious to a conscious level. Carruthers holds that language is constitutively involved in thinking and inner thinking occurs as a form of inner speech.

Further views that bestow a significant role to language in thinking can be found in the works of thinkers like Davidson and Brandom who see thinking as secondary to language. More specifically, for Davidson (1975) thoughts are only attributable to creatures that are interpretable. A creature that we cannot interpret as capable of meaningful speech is a creature that we cannot interpret as capable of possessing contentful attitudes<sup>2</sup>. For Brandom (1994), thought does not take place in language but thought can only be attributed to linguistic agents. Thought and language acquire content through their mutual interrelations. But despite this mutual interrelation, Brandom promotes the significance of language over that of thought since he argues that the objectivity of conceptual norms derives from public linguistic practice.

There are also views that could be seen as somehow equidistant from the two extremes of the above continuum. The view suggested here also lies at the middle of the continuum, and in this section I clarify how it differs from competing views.

---

<sup>2</sup> See also Malpas (2009).

The beginnings of supra-communicative views of language can be traced in William James' (1890/1996) idea that language, and words in particular, allow for a clearer distinction between different concepts<sup>3</sup>. Vygotsky (trans. 1962) further analyses this idea and argues for the influences of natural language on cognitive development and its scaffolding role in guiding behaviour and directing our attention.

This Vygotskian scaffolding idea enjoys support from the work of Berk and Garvin (1984) who show that language (in the form of self-directed vocal or silent speech) guides the actions of children of 5–10 years of age. They found that silent speech is more frequent in cases where the child is alone and when she is engaged in more sophisticated tasks. Bivens and Berk (1990) and Berk (1994) found that increased incidence of silent speech strongly correlated with higher levels of mastering the task in question. From this evidence, Berk draws the conclusion that self-directed speech is a crucial cognitive tool that allows us to direct our attention to specific aspects of a new situation and direct problem-solving actions.

Gauker (1990) also suggests a view of language as a tool for affecting changes in the subject's environment (as opposed to a tool used in representing the world or to publicly express one's thoughts). Language plays the role of a medium through which subjects can grasp the causal relations into which linguistic signs may enter.

For Jackendoff (1996), linguistic formulation allows us a 'handle' for attention and with it the possibility to attend to relational and abstract aspects of thought and thus puts us in a position to scrutinise those aspects.

One of the most prominent views that fall under the 'middle-of-the-continuum' umbrella is that of Clark (1998), and Clark and Chalmers (1998) who argue for the causal potencies of language and suggest that language complements our thoughts. Here, the mind is seen as using external props to reduce the cognitive costs of thinking and enhance performance, especially in regards to formation of structurally highly sophisticated thoughts. Even though thinking can be purely internal, it often relies on available external resources and uses them in a constitutive way. Language is not coincidentally available, but it rather exists to have the function of a prop for thought. Focusing on a connectionist view of the mind, Rumelhart et al. (1986) also treat language as a crucial element for various environmentally extended computational processes.

Dennett (1991) ascribes a more 'extreme' role to language and argues that the advanced cognitive skills that the human mind exhibits are the effects of culture and lan-

<sup>3</sup> Here I follow Clark's (1998) terminology for views that ascribe more than a communicative role to language. Most view presented here are reported in Clark (*ibid.*)

guage. In this sense, the main cognitive differences between the human mind and that of primates like chimpanzees cannot be captured in terms of our initial hardwiring. An even stronger view comes from Whorf (1956) who famously suggests that linguistic differences in grammar and usage shape and alter the ways in which we come to conceptualise and experience the world<sup>4</sup>.

Finally, the language of associationistic thinking hypothesis (LOATH) – the view suggested here – also lies somewhere at the middle of the aforementioned continuum. By and large, LOATH is a view that builds upon associationism and ascribes a significant role to natural language in terms of its contribution to thinking but crucially it is not a constitutive one.

Before starting an elaboration on LOATH, I clarify a number of preliminary issues such as what thinking amounts to, at which point we get conscious access to our thoughts, and what it is for a subject to have endogenous control over her thoughts. Continuing, I present my views on the role of natural language in thinking and provide empirical evidence, mostly from work done with aphasic subjects, in support of my claims. Finally, I assess the consequences of my account by evaluating whether a bigger role should be ascribed to language. In doing so, I examine Carruthers's argument, given that he treats language as constitutively involved in thinking.

## 2 Elaborating on LOATH: thinking is analogous to perceiving

Despite the fact that the role of language in thinking is often subject to a lively debate, few things are settled in regards to what thinking amounts to. For proponents of the view that thinking occurs in language, thinking occurs either in a Mentalese sub-personal code or in the form of inner speech; but as explained above not everyone believes that thinking does in fact happen in the form of language. In the view I suggest here, thinking is analogous to perceiving to the extent that the same representations that were produced during perception of a given object get reactivated when thinking about this object, (e. g. Barsalou 1999; Damasio 1989). That is, on recalling a given concept, e. g. DOG, the brain simulates, to use Barsalou's term, the perceptual experience of a dog. That is, the same neuronal configurations that were active while perceiving a dog would also be activated when thinking of a dog; (see also Barsalou 1999; and Prinz

---

<sup>4</sup> But see Patterson and Fushimi (2006) for evidence that the brain's organisation of language is in fact the same regardless of the language the subject speaks.

2002: esp. chap. three). At the same time, thinking is different from perceiving since the phenomenology of thinking is different for obvious reasons.

Fleshing out the notion of simulation further, consider Damasio's (1989) 'convergence zones' hypothesis. During perception of a given object, different groups of neurons underlie perception of different parts/properties of the object in question. Further down the line of interneural signalling, the output of the neurons that underlie perception of a dog's head, for instance, converge with the output of the neurons that underlie perception of the dog's bark, legs, fur, etc. In this way, these different neuronal ensembles interact in a way that they did not before. And they did not interact before because they are dedicated to the perception of different kinds of stimuli. Convergence zones register combinations of components in terms of coincidence or sequence in space and time (co-occurrence). Representations of the parts of the perceived object are re-constructed by time-locked retro-activation of fragmented records in multiple cortical regions. This is the result of feedback activity from convergence zones. That is, the groups of neurons that fired in a specific way during the sensory experience with the given object are re-activated simultaneously and in exactly the same way that they were activated during the initial perception of the object in question. In this way, a given object is not only perceived as a whole but is crucially also represented in memory (and later on reactivated) as a whole precisely. For what actually gets stored are the simultaneous activation patterns that underlie perception of that object. A key point here is that we only have conscious access at the level of a convergence zone and not at the level of the fragmented representations of an object in geographically spread neuronal groups. It is for this reason that we perceive objects as wholes and not as conjunctions of different features and properties. This claim will play a significant role in the second part of the paper where I reply to Carruthers's claims about the relation between language and thinking.

## **2.1 Endogenously controlled thinking**

LOATH is based on a view of concepts according to which a concept is a structured entity comprised of a set of representations. These representations are formed during perceptual experiences with instances of a given kind. What is also included in this set is the perceptual representation of the appropriate word, e. g. (Barsalou 1999). For instance, the concept DOG is comprised of a set of perceptual representations built out

of experiences with instances of dogs, together with the perceptual representations of the word 'Dog'. These representations get associated on the basis of co-occurrence.

To have the ability to endogenously control the tokening of a given concept, and thus to endogenously control thinking, is to be in a position to activate a given concept in the absence of its referents, i.e. to token a thought on the basis of processes of thinking. In my view, endogenously controlled thinking is merely associative thinking, i.e. current thinking caused by earlier thinking. Here, I am committed to a view of internal thinking which is imagistic, to the extent that conceptual thoughts are built out of concepts, which are in turn built out of perceptual representations. In the suggested view, concepts are associationistic in their causal patterns. That is, every concept is associated with other concepts. Once activated, concepts associated to it to get also activated<sup>5</sup>. For example, consider someone uttering the word 'Trip' and another agent mistakenly hearing the word 'Grip' and as a result starting to think about friction and laws of physics instead of travelling. This is a case where an agent is forming a thought in the absence of an appropriate stimulus, seemingly in a spontaneous but actually in an associative manner. In the previous example, the subject in question forms a thought without being confronted with an instance of the kind in question, in this case the word 'Grip'.

Note here that endogenous control over concepts (i.e. the ability to activate a concept in the absence of its referents) could also be acquired in different ways to the one suggested here. For instance, non-linguistic animals might acquire endogenous control over their concepts by associating a given set of representations to some sort of non-linguistic action, e.g. goal-directed actions over which they do have endogenous control. This might also be the case with human subjects at early developmental stages. The suggested hypothesis then is that when a subject finally does acquire a certain degree of linguistic sophistication, the process of activating a concept in a top-down manner is achieved by virtue of associated linguistic symbols being activated. Note also that there are cases when we form a thought 'on the fly' by activating a set of images in a top-down manner and consciously manipulating those images. For instance, consider being in a store and trying to think whether a particular sofa would fit in your living room. This is a clear case when a thought is formed by virtue of images being consciously manipulated. Clearly, the activated images/representations of the inner space

---

<sup>5</sup> Evidence in support of the suggested associationistic view of thinking can be found in the work of Elman et al. (1996), amongst others, who argue that artificial neural networks can be highly constrained by the network's current weight assignment.

of one's living room do not have to be constitutive parts of the concept LIVING ROOM. What is important here though, is that these representations are only activated in virtue of their associations to certain concepts, which in turn are also activated either during or (right) before the activation of the imagistic thought in question.

In a nutshell, endogenous control over thoughts is acquired by associating concepts with linguistic symbols. My hypothesis here is that we have endogenous control over our production of linguistic items, given that we are able to produce linguistic utterances at will (or silent talking to ourselves). It is this executive control over linguistic utterances that gives us endogenous control over our thoughts.

## **2.2 Associationist accounts and propositional thoughts**

On the previous pages, I presented LOATH, an associationistic view of thinking in which language plays a significant but not a constitutive role in thinking. As such, LOATH might be subject to the objection that it cannot account either for propositional thinking or for compositionality of thought. However, I suggest that those problems could be solved by appealing to natural language. Let me elaborate.

The reason why it is not obvious how LOATH could account for propositional thinking is that it at best describes how interconnected concepts get activated but does not explain the propositional-syntactic properties that thoughts, in the form of inner speech, actually have. In a sense, propositional thoughts somehow involve or are about a number of different items for which we have individual concepts. In a propositional thought, those individual concepts are structured together. The way that individual concepts are structured is important, since the same concepts can be structured in different ways. For instance, there is a clear structural difference between the thought 'John loves Mary' and the thought 'Mary loves John' (cf. Fodor & Pylyshyn 1988). The difference between propositional and non-propositional thoughts is that propositional thoughts are complex structured entities that are true or false. In this sense, some thoughts seem to have a unified coherent propositional structure and content<sup>6</sup> whereas individual representations seem to lack these features. The question then is how is it that we can move from the individual representations to having mental representations that have this kind of propositional content?

In reply, a single thought gets to be propositional in structure and content by piggybacking on language. My starting point is that sentences are syntactically structured.

---

<sup>6</sup> Structure and content are different since there could be mental atoms that have propositional content.

Sentences are unified structured entities and they unify and structure the concepts associated with the components into a propositional thought in a way that mirrors the unity and structure of the sentence. A thought gets to have propositional content by virtue of concepts (for objects or features) being associated with individual words or phrases; the sentence provides a kind of unity. In this sense, it is the conventional grammatical unity and structure of the sentence that unifies those concepts and orders them in a certain way. It is by virtue of this, that thoughts have particular propositional content. Furthermore, the external linguistic item orders and, in a sense, binds the different constitutive-to-the-proposition parts together and unifies thoughts.

As it happens, most of those raising the objection of propositional thinking against associationist accounts seem to find a better alternative in LOTH. What is appealing about LOTH here is that Mentalese is structurally(/grammatically) analogous to natural language. In this way, a thought is tokened as propositional. As explained in Section 4 below, Carruthers also objects to associationistic accounts and he favours a view in which natural language is constitutively involved in thinking, i. e. natural language *becomes* a language of thought. Thus, for Carruthers, thoughts do not occur in Mentalese, but rather natural language is itself the medium through which conscious thinking is conducted. In this sense, thoughts are propositional in terms of natural language, which of course is propositional, being constitutively involved in thinking. Both of the above theses can account for propositional thoughts while it is claimed that associationist accounts cannot.

As shown above, representing linguistic items allows an agent to escape from the patterns of association that they would have been locked into had it not been for the conventional structure of sentences and their conventional patterns of implications. In this way, an agent can extend the repertoire of these associations beyond the actual inductive pattern of objects as she has encountered them. For instance, one can think of black swans even though one has only seen white ones. This is possible because some of the patterns of associations that one can fall into using by the concept SWAN are underpinned by and arise from the conventional structure of language. So, the (version of the) problem of propositional thinking (that I focus on here) is solved by latching onto the external artefacts of public language.

In a nutshell, I claim that an agent could extend the repertoire of associations beyond a) their hardware endowment and b) the patterns of experiences that their history has given him/her by forming associations with linguistic items. These latter associations are much less constrained by the agent's individual experience history and much more



constrained in other ways, i. e. the rules of grammar, the norms of epistemology and so forth. It is in this way that thinking in a more flexible and open-ended way is achieved. Clearly the suggested view bears enough similarities to the Extended Mind Hypothesis (briefly examined above) and Clark's (2005) suggestions. The main difference between the two is that my focus is at a more general level. In particular, I do not focus on specific cognitive tasks that might be propped up by language or how specific processes, like those involved in perceptual categorisation, are facilitated or influenced by language. Instead, my focus here is on how language affects thought formation.

### **2.3 Associationism and compositionality**

Another problem that associationistic accounts of thinking face is the problem of compositionality. One of the characteristics of concepts is that they can combine compositionally. The problem for associationistic accounts is that it is not clear how they can give an account of the ways in which concepts, the ingredients of thoughts, can be put together to produce something where the meaning of the whole depends on the meanings of the parts and the ways in which they are put together. The problem of compositionality is particularly vivid for prototypes. For instance, the conjunction of PET and FISH gives PET FISH. However, the prototypical pet is something like a cat or a dog; the prototypical fish is something like a trout while the prototypical pet fish is rather a goldfish (cf. Fodor and LePore 1996). If thoughts are formed in an associationistic manner, how is it that concepts can combine compositionally?

This is a very interesting problem which, however, lies beyond the scope of this paper. That said, a solution can be suggested; one that can be seen as another way in which language influences thinking. My main claim is that since thinking piggybacks on language, the solution to the problem of how thinking is compositional piggybacks on the solution of how language is compositional. Admittedly, this is a different problem, and one on which I do not further elaborate here since it lies in the realm of philosophy of language.

Returning to the problem of compositionality of thought and assuming that language is compositional, according to LOATH the concept PET FISH is a folder that contains perceptual representations. At this point, I align myself with Prinz's semantic account (2002), according to which, in order for C to refer to X, the following two conditions, (a) & (b), have to be fulfilled:

- (a) Xs nomologically covary with tokens of C

(b) An X was the (actual) incipient cause of C

In this sense, the incipient causes of PET FISH can either be instances of pet fish or representations of pets and representations of fish. What is important, in terms of the semantics, is that PET FISH has to nomologically covary with pet fish rather than a disjunction of pet and fish. In other words, that PET FISH will be activated every time the subject is confronted with or thinking of an instance of pet fish. This is a nomic or counterfactually supporting relation. The reason why PET FISH nomologically covaries with pet fish is that the concept's functional role is constrained by the constraints on the uses of the word that are set by the agent's locking into the conventions of how conjunctions are formed. In this sense, an agent is a participant in a convention and it is via the association between the word and the concept that the functional role of the conjunctive concept is constrained. Taking a closer look at the constitutive representations of PET FISH now, these representations can be representations of pets like cats and dogs as well as representations of fish. Note that those representations are idle in the functional role of the concept. The latter is more constrained by its link to the words.

I do not further elaborate on the problem of compositionality here. However, it should be clear that even though proponents of associationist accounts of thinking do not have a fully fleshed out solution, they can tack the solution that philosophers of language will offer to the problem of how language can be compositional onto their claims about thinking.

### **3 LOATH and empirical evidence: thoughts, language, and the evidence from aphasia.**

In the following sections, my target is to examine LOATH against empirical evidence. I do that by arguing that it is not clear how proponents of the communicative conception of language could account for evidence gathered from work done with aphasic subjects, which shows that aphasics cannot form endogenously controlled thoughts. The reason why this is useful for my purposes is that aphasia is generally understood as a language disorder. Admittedly, there are different kinds of aphasia and each kind can affect linguistic comprehension and communication to different degrees. Furthermore, several brain regions are affected in cases of aphasia. By and large though, aphasic subjects are unable to understand and use spoken or written language due to brain lesions. To

this extent, I focus on the linguistic aspects of aphasia<sup>7</sup>. Furthermore, even though – as mentioned already – language plays a key role in the acquisition of endogenously controlled thought, stimulus driven thought might not necessarily involve language. For instance, it might be that a stimulus produces a perception, which in turn causes activation of concepts by associationistic links that are piggybacking on language. In this sense, a fair quantity of stimulus-driven, yet fairly complex, cognitive processing can occur in aphasics. However, the suggested account predicts that there will be a dramatic drop in performance amongst aphasics executing sequential and reasonably difficult tasks and more specifically in performance of tasks in which endogenous control of thought is required. This is because, as previously explained, a key claim of LOATH is that endogenous control is acquired on the basis of language, and aphasics are by and large subjects with ‘compromised linguistic systems’.

In order for proponents of the view that language is not involved in endogenous control of thinking to accommodate evidence similar to this presented below, they need to establish a double dissociation between language and endogenous control. That is, they have to show that aphasic subjects – who are linguistically impaired – can nevertheless activate concepts in a top-down manner and also that (at least in some cases) subjects who are linguistically unimpaired cannot activate concepts in a top-down manner.

In general terms, the empirical evidence presented here shows that there is a correlation between linguistic impairments and endogenously controllable thinking. Thus, the option available to proponents of views contrasting the one suggested here is the following: First of all, they need to adopt a *massively* modular view of the mind. In this case, it can be claimed that a distinct module governs activation of concepts in a top-down manner, and perhaps a separate module (or modules) governs all other linguistic functions. It can then be claimed that in the cases presented below, both the language module and the top-down-activation-of-concepts module are impaired. Nevertheless, those two modules are distinct from each other<sup>8</sup>. If a massively modular view of the

---

<sup>7</sup> Section §3 has been significantly revised after publication of this volume. The main reason for this is that aphasia is not an absolute language deficit, as it is implied here, and more relevant and recent empirical evidence has been considered. However, in later drafts it is shown that the suggested view still enjoys significant empirical support from work done in perceptual processing and categorisation tasks.

<sup>8</sup> Evidence in support of this claim can be found in (Pinker 1994), (Brock 2007) and (Mervis and Beccera 2007). The latter demonstrate that language abilities in Williams Syndrome are no more than would be predicted by non-linguistic abilities. Furthermore there is evidence suggesting that specific language impairments (SLI) related to use of language might be of a more general cognitive nature (Norbury, Bishop & Briscoe 2001); (Bishop 1994); (Kail 1994), amongst others). I do not further elaborate on this issue here.

mind is adopted, the aforementioned double dissociation can be achieved since there might be cases where only one of the above (two) modules is impaired while the other is spared. Note here that a Fodorian view of the mind as *merely* modular cannot account for this evidence since, in that view, there is only one language module responsible for all linguistic functions. There are various reasons why a massively modular view of the mind is problematic, even though I do not further elaborate on this issue here<sup>9</sup>. Having dealt with the negative argument supporting the suggested view, I now turn to positive considerations.

### 3.1 Drawing and recollection in aphasic patients

Gainotti et al. (1983) systematically examined the effects of aphasia on drawing from memory. Furthermore, they investigated the relationship between the performance of subjects and the clinical form of aphasia, the severity of language impairment at the semantic level of language integration<sup>10</sup>. They also investigated whether aphasics were more impaired than subjects with right-brain and left-brain injuries but without any aphasia. All of these results were compared to the results from a control group of normal subjects of the same mental age, and comparisons were drawn between performances of the impaired and control subjects.

During these experiments, subjects were briefly shown drawings of simple objects with a characteristic shape (a nail, a pear, a key, a comb, a cluster of grapes, a table, a hand and an umbrella). The experimenters made sure that the subjects had analysed the details of the object in question and recognised it, by asking them to name the object in question. The experimenter then hid the object away and the subject was asked to draw the same object from memory. It should be noted that the instructor asked the subject to draw the object by naming it, i. e.: “Could you please draw the comb that you just saw?” This process was repeated for the ten above objects. Finally, two independent judges evaluated the drawings. Two points were given to drawings that contain most of the object’s characteristic features and thus could be easily recognised. One point was given

---

<sup>9</sup> For instance, evidence from (Gregory 1970) and (Barnes, Bloor and Henry 1996) could be used to counter the cognitive impenetrability thesis. The cited evidence shows that cognition seems to penetrate perception. This in turn counters one of the main characteristics of modules, namely informational encapsulation. I do not further elaborate on this here. See also (Prinz 2006) for an extended attack on the modular view of the mind on different grounds.

<sup>10</sup> An impairment at the semantic level of language integration can be detected by asking patients to discriminate the meaning of a given word by choosing from an array of semantically similar alternatives the object corresponding to the stimulus word. This tests the semantic level of language integration (*ibid.* 616).

to drawings that contained some of the characteristic features of the object and could still be recognised. Zero points were given when the drawn object was unrecognisable. The points given by the two judges were added and thus each subject could score a maximum possible score of forty.

At a different stage of the test, subjects were tested for constructional apraxia and were given models and figures, ten in total, to copy. Once again, two independent judges evaluated the drawings (copies) on the basis of a rating system similar to the one described above.

On the basis of their symptoms, aphasic subjects were divided into four major aphasic syndromes (Broca's, Wernicke's, anomia and conduction aphasia). I will not further examine the different types of aphasia since, as shown from the results, such a classification is not central for my present purposes.

### **3.1.1 Results**

The mean scores obtained by aphasic subjects from the Drawing from Memory Test and Copying Drawing Tests are presented in table 1, and are compared to the average scores of normal controls and nonaphasic subjects with right- and left-brain lesions. As shown in the first column, aphasic subjects scored the lowest means in the drawing from memory test while the difference in the copying drawing test was not as dramatic. As a matter of fact, aphasics performed slightly better in the latter test in comparison to subjects with right-brain damage, which are considered by the examiners as the most appropriate control group, given the damaged brain areas in aphasic subjects.

Mean scores	<b>Aphasic patients (n = 57)</b>	<b>R. brain- damaged (n = 67)</b>	<b>Nonaphasic L. brain-damaged (n = 44)</b>	<b>Normal controls (n = 23)</b>
<b>Drawing from Memory</b>	21.59	28.08	31.16	33.78
<b>Copying Drawings</b>	33.83	33.53	37.70	37.04

Table 1: Results obtained by aphasics, normal controls, and non-aphasic right and left brain-damaged patients on the tasks of drawing from memory and of copying geometrical drawings (adapted from Gainotti et al., 1983).

On commenting on the obtained results, Gainotti et al. remark that aphasics are significantly more impaired than any other group on the 'drawing objects from memory' test, but not on the test for the 'copying drawing' tests. On these grounds, they argue that

poor performance of aphasic subjects at the drawing from memory test is a symptom that cannot be considered as a particular aspect of a generic visuo-constructive disorder.

On testing subjects with different aphasic syndromes and different levels of severity, the obtained results showed that the performance of the subjects was not influenced, at least not to a significant degree, by the type of aphasic syndrome or the severity of the damage. Based on these results, Gainotti et al. claim neither the type of aphasic syndrome nor the severity of the damage seem to be crucial with regards to the deficit in drawing from memory of aphasic patients.

The most striking result for my present purposes from the Copying from Memory test is that aphasic subjects with semantic-lexical impairments performed systematically poorly. At the same time, aphasic subjects with no such semantic-lexical impairments performed significantly better. In this sense, there is a strong correlation between aphasic subjects with semantic-lexical impairments and incompetence in the drawing from memory test. These results are illustrated in table 2.

	<b>Presence of semantic-lexical impairment (n=30)</b>	<b>Absence of semantic-lexical impairment (n = 27)</b>
<b>Copying Drawings</b>	33.54	35.62
<b>Drawing from Memory</b>	17.52	26.33

Table 2: Mean scores obtained by aphasic patients with and without semantic-lexical impairment (adapted from Gainotti et al., 1983)

In a nutshell, the results that Gainotti et al. obtained from the aforementioned experiments show that: first of all, aphasic subjects were significantly poorer than control groups at the drawing from memory test. Secondly, the examiners did not detect any significant correlation between the type of aphasia and severity of the impairment in the results of the drawing from memory task. Most importantly though, a significant correlation was detected between poor performance at the drawing from memory task and disruption at the semantic-lexical level of language integration.

The importance of these findings, for my purposes, stems from the fact that they explicitly show that aphasic subjects have compromised abilities with regards to accessing representations and activating concepts stored in their memory, mainly in the absence of the referent of the concept in question. This claim gathers pace from the following facts: a) the participating aphasic subject did not suffer from any form of visuo-constructive disabilities; b) a significant correlation between impaired drawing

from memory and disruption at the semantic-lexical level of language integration was detected; c) aphasic subjects suffer from inability to use and/or understand spoken or written language. In this sense, the above results are suggestive of the claim that language renders possible, or in any case facilitates, the ability to endogenously control stored representations. I will try to build a stronger case for this claim by appealing to further empirical evidence in the following paragraphs. Before that though, allow me to briefly discuss a methodological issue.

A possible argument against the methodology or the design of these experiments is that the subjects were not asked to draw anything from memory (but a given object). In this sense, Gainotti et al. cannot securely eliminate the possibility that the poor performance of the subjects was influenced by a short-term memory defect and not because of a conceptual inability to reproduce from memory the form of objects that have a characteristic shape<sup>11</sup>. In reply, Gainotti et al., claim that this objection is unsound since the examiners did not ask the subjects to reproduce from memory a more or less meaningful object but rather tried to raise in the subject the concept of the object, by naming it, and then asked the subject to draw the named object. Furthermore, they claim, by reference to the work of Faglioni and Spinnler (1969), that it is right-brain-damaged patients, and not aphasics, who are particularly impaired in tasks of immediate and delayed memory of meaningless visual patterns.

Gainotti et al.'s results enjoy support from Bay's (1962) claims that aphasics are unable to reproduce from memory the crucial characteristics of a given object due to a basic conceptual disorder.

In an attempt to focus only on the conceptual (as distinct from linguistic) competences of aphasics, Bay (1962) conducted a different series of experiments. Aphasic subjects were given an incomplete drawing, e.g. a cup without a handle, and were asked to complete the drawing, i.e. to draw the missing part. Originally, this test was conducted by Meili who asked subjects to name the missing part. Meili's target was to give instructions without using any verbal elements and hence to focus on the conceptual abilities of aphasics. Bay went a step further by asking subjects not to name but to draw from memory the missing part. Bay reports that not a single subject was able to draw the missing part unless she was unable to name it. (At a later stage, they asked subjects to model from memory objects of their choice in plastic material in order to eliminate possible errors arising from the transformation from a three-dimensional to a two-dimensional object. For this transformation presupposes a knowledge of rules, such as of perspective, which in turn cannot be presumed in all subjects. The results were similar to the ones from drawing).

---

<sup>11</sup> Conceptual inability is an inability to reproduce (for instance, when drawing a given object) the basic characteristics of the object in question.

Based on the results of their experiments, Gainotti et al. suggest that Bay's suggestions could be made more specific by claiming that there is a strong correlation between conceptual and semantic-lexical disintegration. By stressing this relation, findings about aphasics who demonstrated excellent capabilities in drawing from memory can be accommodated by claiming that language disturbances in those subjects were due to phonological and/or phonetic disorders and not due to a semantic-lexical impairment. Had it been the case that subjects were able to think of the right answer to the examiner's question but were not in a position to utter the relevant words, then the obtained results would not have shown anything significant about the workings of the cognitive system of aphasic subjects and hence could not be used in favour of the view presented here.

Semantic-lexical impairments in aphasic subjects are also significantly related to their inability to understand the meaning of symbolic gestures (evidence reviewed in Gainotti, 1983). In a similar fashion, Gainotti et al. (1979) showed that there is a relation between semantic-lexical disturbances and the inability of the aphasic subject to appreciate relationships between pictured objects which have different levels of conceptual similarity, e. g. chair and stool, bowl and cup, etc.

### **3.1.2 Interpreting the results**

From the results of the above experiments it is shown that there is a significant correlation between semantic-lexical impairments and particular deficiencies such as an inability to appreciate conceptual similarities between objects or understanding simple gesturing. The most interesting result for my present purposes is the correlation between semantic lexical impairments and inability of aphasics to draw from memory. The reason is that recalling is a characteristic case of endogenously controlled thinking. Given that aphasics have severe linguistic impairments, it might now be claimed that their inability to endogenously activate a concept or a thought is down to their linguistic impairments. This is especially the case given the characteristic relation between semantic-lexical impairments. Here is what I mean by this. First of all, subjects were able to copy the perceived object and hence there were no signs of constructional apraxia. Also, the instructor asked the subject to draw the object in question by using its 'name' (e. g. "draw the comb that you just saw"). In this way, the instructor was in a position to target the subject's linguistic competences. On these grounds, any inability to draw the object in question was due to the subject's inability to think of a comb, to continue with the same example, or to activate their concept COMB. Had it been the



case that subjects were able to activate their concept COMB then perceptual representations of combs would have also been activated and they would be able to ‘copy’ them from memory onto the piece of paper in front of them. From the above I suggest that we are able to activate a concept or form a specific thought on the basis of linguistic labels that we have for the concept in question. Further generalising from that, I suggest that a subject’s linguistic capacity is what provides endogenous control over their concepts.

Further evidence in support of the suggested role for language can be found in Farias et al. (2006), who shows that drawing facilitates naming; Swindell and Greenhouse (1988) who study patients with right- and left-brain damage; and (Bay (1962) who shows that aphasics are unable to reproduce from memory the crucial characteristics of a given object due to a basic conceptual disorder.

## **PART II**

### **4 Shall we give language an even bigger role?**

As mentioned above, according to Carruthers (2005), natural language is constitutively involved in specific kinds of human thinking, particularly in conscious propositional thinking. He claims that natural language is not merely a communicative tool of inner thinking. Rather, that natural language is itself the medium through which conscious propositional thinking is conducted, i. e. Mentalese is a natural language. In this sense, for Carruthers everyone’s Mentalese will be one of the natural languages they speak. (For Fodor, on the other hand, Mentalese is distinct from any natural language).

Carruthers has two arguments in support of the claim that language is constitutively involved in thinking. 1) He uses evidence from Hurlburt’s (1990, 1993) work that suggests that thinking happens mostly in language, and 2) he offers a philosophical argument that shows that thinking has to happen in language or otherwise we will be ‘self-alienated’. I examine both in detail below, while my main focus is on Carruthers’s philosophical argument.

In regards to his first argument, Carruthers’s motivation stems from evidence from introspection and in particular from the work of Hurlburt, who famously uses a characteristic method for investigating inner life. Subjects are not brought into the lab and asked to perform some task of introspection. Rather their everyday life is interrupted by randomly occurring beeps and they are interviewed later on to report what was going on in their minds when the interrupting beep happened. Subjects reported that in a

significant majority of the cases, where they introspected, inner thinking occurred in natural language sentences. There were also cases where subjects reported that their thought did not occur in the form of inner speech. For Carruthers these latter cases are instances of a systematic illusion. That is, what we take to be non-inferential thinking is in fact a swift bit of self-interpretation, one that we merely do not realise. Carruthers provides support to his claim by referring to the work of Nisbett and Wilson (1977), who show that there are a number of circumstances in which subjects confabulate self-explanations that are manifestly false, but without realising that this is what they are doing. Given that for Carruthers non-inferential access to a thought means that language is constitutively involved in that thought, Carruthers's claims about agents having a systematic illusion seem to contrast Hurlburt's claims that there are what Hurlburt calls 'amodal' and non-linguistic thoughts. Once a subject reported that they enjoyed a non-linguistic thought, Hurlburt followed this up with questions asking for more details about the thought, and subjects consistently replied that it did not involve any language, or images, that they had no visual phenomenology or anything similar. Note that Carruthers argues that the subjects in question are having a systematic illusion since he only allows non-linguistic thoughts to be of the form of visual or some other sort of images but not amodal. It should be clarified at this point that Carruthers does not claim that all thought is linguistic. He accepts that some conscious thoughts (images of some sort) can be non-propositional. What Carruthers has in mind at this point are exactly the sort of cases in Hurlburt's studies where subjects reported that there were instances when they were not thinking in inner speech. As explained, according to Carruthers these are instances of a systematic illusion, (while for Hurlburt they are amodal thoughts). In line with what has been said in Section 2.1, I suggest that those thoughts might well be conscious manipulations of images which got activated by virtue of their associations to concepts that were activated either simultaneously or right before the imagistic thought in question.

I have been arguing that thinking is imagistic and non-linguistic. In this sense, it might be argued that Carruthers's view and the one suggested here are to a certain extent compatible to each other. Note though that there are crucial differences. For Carruthers, only some thoughts can be non-linguistic while I suggest that all thoughts are imagistic in some way (visual, auditory, somatosensory, emotional, etc.). Clearly, there is a tension between allowing space for non-linguistic thoughts and Carruthers' claim that language is constitutively involved in thinking. Acknowledging this tension, Carruthers restricts his claims about the role of language to conscious propositional

thought. Crucially for present purposes, however, Carruthers asserts that imagistic thoughts (apart from not being fully propositional) have content that can only awkwardly and inaccurately be reported in the form of a 'that' clause, (2005, 117). Carruthers argues that imagistic theories of meaning or imagistic theories of thought are not sound – as the standard arguments against them show<sup>12</sup>. On these grounds, Carruthers argues that imagistic thinking cannot colonise the whole domain of conscious thought, unless the images in question are images of natural language sentences. In the latter case, the imaged sentences will have the same causal role as the thought that produced them, and will thus be constitutive of conscious thinking. The view I suggest here is different in that thoughts and linguistic items are associated but are distinct from each other.

Next, I turn to examine Carruthers's philosophical argument in favour of the claim that language is constitutively involved in conscious thought. According to Carruthers, proponents of the communicative conception of language cannot account for the privileged nature of introspection. The reason for this is that if language is seen as not essentially implicated in thinking but rather as a medium that facilitates the communication of thought, then the kind of access an agent has to her own thoughts is analogous to the kind of access she has to the thoughts of a third person. Carruthers admits that an interpretation will have to take place regardless of whether an imaged sentence is constitutive of an occurrent thought or caused by the occurrence of a thought existing independently of it. The difference is that if a communicative conception of language is accepted, then the process of interpretation will occur downstream of the thought, i. e. a thought will be tokened first and then the representation of that thought will be interpreted by the agent herself, in the case of inner speech. On the contrary, in the cognitive conception of language that Carruthers suggests, the causal role of the token thought in question is dependent upon its figuring as an interpreted image. In this case, it is the imaged (and interpreted) natural-language sentence that results in the further cognitive effects characteristic of entertaining a given thought.

Carruthers (2005, 117–8) formulates his argument that language is constitutively involved in conscious thought in the following way:

1. Conscious thinking requires immediate, non-inferential, non-interpretative access to our occurrent thoughts, and that access is distinctively different from that of other people.

---

<sup>12</sup> What Carruthers has probably in mind here is arguments against verificationism and some sort of verificationist semantics.

2. Occurrent propositional thoughts either get articulated in inner speech or not. In case they do, then inner speech is either constitutive of the thought-tokens in question or not.
3. If the manipulation of natural language sentences in inner speech is not constitutive of propositional thinking, then our access to the thoughts expressed in inner speech is interpretative, and similar to the sort of access to thoughts of others, and hence such thoughts of ours do not count as conscious (by 1).
4. The sort of access that we have to those of our occurrent propositional thoughts that do not get expressed in inner speech also involves self-interpretation. Hence, such thoughts too are not conscious (by 1).
5. So, if we engage in conscious propositional thinking at all, then natural language sentences must be constitutively involved in such thinking (from 1, 2, 3, and 4).
6. But we do sometimes engage in conscious propositional thinking.
7. So, natural language is constitutively involved in conscious thought (from 5 and 6).

It should be clear by this point that I agree with Carruthers that language plays a bigger role than merely communicating our thoughts. I believe that language empowers us not only to gain conscious access to our thoughts but also to shape new thoughts. However, I believe that Carruthers is mistaken in thinking that natural language and Mentalese have to be identified in order for us to be in a position to explain our non-inferential access to our thoughts. In other words, I believe that premise three of the above argument is false and hence that Carruthers's conclusion does not follow.

#### **4.1 Contra Carruthers: distinguishing language from thought**

Carruthers argues that in order to have non-inferential access to our thoughts, inner speech needs to be constitutively involved in propositional thinking (P3). Carruthers is mistaken in claiming that this is the only way in which non-inferential thinking can occur. One alternative way to have non-inferential access to our thoughts is associative thinking. For instance, it might be that the transition from the word to the concept that has the very same content that a given word expresses is an associationistic link. In the suggested view, perceptual representations and words are associated in memory. In Damasio's terminology, the realisation of this association occurs at the level of a convergence zone. Note that this is not a case of language being constitutive to thoughts. Rather it is a case of co-activation of a concept's different subparts: perceptual representations of the appropriate word (A) and representations formed during perceptual experiences with instances of a given object (B). This occurs by virtue of an instance

of a word activating A, which in turn activates B resulting in the concept's activation as a whole. Nevertheless, and importantly, this kind of thinking is not interpretative. It is not that an agent hears a word, say 'Cat', and then tries to guess or infer what the word means. Instead, on hearing the word 'Cat' the concept CAT is activated. In this sense, access to thinking is neither interpretative nor constitutive. Next, I flesh out in more detail the way in which non-constitutive non-inferential thinking is realised in the brain. First, I show that language is not constitutively involved in thinking and continue by elaborating how associationistic thinking can be non-inferential, in the way, for instance, Carruthers suggests.

As explained in the first part of the paper, I take concepts to be built out of perceptual representations of instances of a given kind and also perceptual representations of words. In this sense, perceptual representations of objects and words are distinct from each other and are brought together under the process of concept formation. My claim then is that these representations (or rather the neurons that underlie them) are converged together at a level similar to that of a convergence zone. The claim that representations of objects and words are distinct is key here since it is partly on these grounds that I go against Carruthers's claim that language is constitutively involved in thought formation. It is just that we only get to have conscious access at the level where representations of words and objects are converged. In this sense, an agent can only access representations of objects and words simultaneously and treat them as if they were constitutive parts of a concept/thought. It is in this way that I can account for non-inferential access to thinking.

Going back to Carruthers's argument, his claim was that in order to be able to account for the immediate access to our thoughts, imaged words and thoughts would have to be identified – at least in the case of conscious propositional thought. In this section, I have shown that associationism provides an alternative way for achieving non-interpretative thinking without language being constitutively involved. In my view, the relationship between a thought and its representation in self-knowledge is brute causation. The particular transition between a first order thought and a second order thought are causally and not constitutively related. Thus, the relationship between a first order and a second order thought is not constitutive as Carruthers argues for but rather a causal associative one.

On the basis of the claims made in this part of the paper, it is argued that thought and language are not constitutively connected. Because, as shown, thought can occur without language. And when thought does require language it is in order for thought

to have features like propositional form and be endogenously controllable. Given our basic perceptual hardware and associationism as the engines of thinking, our thought would not have these features had it not been for language.

## 5 Conclusion

In this paper, I have examined the relation between language and cognition. My starting points were that thinking is imagistic, to the extent that conceptual thoughts are built out of concepts, which are in turn built out of perceptual representations; and that concepts – the building blocks of thoughts – are associationistic in their causal patterns. On this basis, I have presented a view of thinking according to which language plays a crucial – but not a constitutive – role in thought production. I suggest that unlike available views, the account presented here enjoys support from independent empirical evidence obtained from work done with aphasic subjects, while at the same time avoids the controversies of views which maintain that inner speech needs to be constitutively involved in propositional thinking in order to have non-inferential access to our thoughts. I also argued that the associationistic account of thought production I presented in this paper could accommodate propositional thinking and compositionality.

## Acknowledgements

I would like to thank Finn Spicer, Anthony Everett, Jesse Prinz, Michelle Montague, Oystein Linnebo, and Patrice Soom for their help and comments on earlier drafts, as well as audiences in the UK, Netherlands, Germany, Spain, and Greece for their feedback. Also, I would like to thank Paschalis Kitromilides and Byron Kaldis for their support.

## Role of the funding source

Research for this paper was funded by the Onassis Foundation, Athens – Greece (ZF 75). The sponsor was not involved in the study in any way.

## 6 References

Barnes B., Bloor, D. and Henry J. (1996). *Scientific knowledge – A sociological analysis*. London: Athlone.

- Barsalou, L. W. (1999). Perceptual symbol systems. *Behavioral and Brain Sciences*, 22, 577–609.
- Bay, E. (1962). Aphasia and nonverbal disorders of language. *Brain*, 85, 411–426.
- Berk, L. (1994). Why children talk to themselves. *Scientific American*, November: 78–83.
- Berk, L. and R. Garvin (1984). Development of private speech among low-income Appalachian children. *Developmental Psychology*, 20, 2, 271–86.
- Bishop, D. V. M. (1994). Grammatical errors in specific language impairment: Competence or performance limitations. *Applied Psycholinguistics*, 15, 507–550.
- Bivens, J. A., and Berk, L. E. (1990). A longitudinal study of the development of elementary school children's private speech. *Merrill Palmer Quarterly*, 36, 443–63.
- Brandom, R. (1994). *Making it explicit: Reasoning, representing, and discursive commitment*. Cambridge, MA: Harvard University Press.
- Brock, J. (2007). Language abilities in Williams syndrome: A critical review. *Development and Psychopathology*, 19, 1, 97–127.
- Carruthers, P. (1998). Conscious thinking: Language or elimination? *Mind and Language*, 13, 4, 457–76.
- Carruthers, P. (2005). *Consciousness: Essays from a higher order perspective*. Oxford: Clarendon Press.
- Carruthers, P. (2008). Language in cognition. In E. Margolis, R. Samuels, & S. Stich (Eds.), *The Oxford handbook of philosophy of cognitive science* (pp. 382–401). Oxford University Press.
- Chomsky, N. (1988). *Language and Problems of Knowledge*. MIT Press.
- Clark, A. (2005). Beyond the flesh: Some lessons from a mole cricket. *Artificial Life*, 11, 1–2, 233–44.
- Clark, A. (1998). Magic words: How language augments human computation. In P. Carruthers & J. Boucher (Eds.), *Language and thought: Interdisciplinary themes* (pp. 162–183). Cambridge: Cambridge University Press.
- Clark, A., Chalmers, D. J. (1998). The extended mind. *Analysis*, 58, 1, 7–19.
- Damasio, A. R. (1989). Time-locked multiregional retroactivation: A systems-level proposal for the neural substrates of recall and recognition. *Cognition*, 33, 25–62.
- Davidson, D. (1975). Thought and talk. In his *Inquiries into truth and interpretation* (pp. 155–170). Oxford: Oxford University Press.
- Dennett, D. (1991). *Consciousness Explained*. New York, Little Brown and Co.

- Elman, J. L., Bates, E. A., Johnson, M. H., Karmiloff-Smith, A., Parisi, D., Plunkett, K. (1996). *Rethinking innateness: A connectionist perspective on development*, Cambridge, MA: MIT Press.
- Farias, D., Davis, C., Harrington, G. (2006). Drawing: Its contribution to naming in aphasia. *Brain and Language*, 97, 1, 53–63.
- Fodor, J. (1978). *Representations: Philosophical essays on the foundations of cognitive science*. Cambridge, MA: MIT Press.
- Fodor, J. (1983). *The modularity of mind: An essay in faculty psychology*. Cambridge, MA: MIT Press.
- Fodor, J. (1987). *Psychosemantics: The problem of meaning in the philosophy of mind*. Cambridge, MA: MIT Press.
- Fodor, J. A., Pylyshyn, Z., W. (1988). Connectionism and cognitive architecture: A critical analysis. *Cognition* 28 (1–2), 3–71.
- Gainotti, G., Miceli, G., Caltagirone, C. (1979). The relationships between conceptual and semantic-lexical disorders in aphasia. *International Journal of Neuroscience*, 10, 1, 45–50.
- Gainotti, G., Silveri, M., C., Villa G., Caltagirone C. (1983). Drawing objects from memory in aphasia. *Brain*, 106, 3, 613–22.
- Gauker, C. (1990). How to Learn a Language like a Chimpanzee. *Philosophical Psychology*, 3, 1, 31–53.
- Gregory R. L. (1970). *The intelligent eye*. New York: McGraw-Hill.
- Grice, P. (1957). Meaning. *Philosophical Review*, 66: 377–88.
- Grice. P. (1968). Utterer's meaning, sentence meaning, and word-meaning. *Foundations of Language*, 4, 225–42.
- Grice. P. (1969). Utterer's meaning and intentions. *Philosophical Review*, 68, 147–77.
- Grice. P. (1982). Meaning revisited. In N.V. Smith (Ed.) *Mutual Knowledge* (pp. 223–243).
- Grice, P. (1989). *Studies in the ways of words*. Cambridge, MA: Harvard University Press. New York: Academic Press.
- Hurlburt, R., T. (1990). *Sampling normal and schizophrenic inner experience*. New York: Plenum Press.
- Hurlburt, R., T. (1993). *Sampling inner experience in disturbed affect*. New York: Plenum Press.
- Jackendoff, R. (1996). How language helps us think. *Pragmatics and Cognition*. 4, 1.
- James, W. (1890). *The Principles of Psychology* (2 vols.). New York: Henry Holt (Reprinted Bristol: Thoemmes Press, 1999).



- Kail, R. (1994). A method for studying the generalized slowing hypothesis in children with specific language impairment. *Speech Hearing Research*, 37, 418–421.
- Levelt, W. (1989). *Speaking: From intention to articulation*. MIT Press.
- Malpas, J. (2009). Donald Davidson. *Entry in Stanford encyclopedia of philosophy*: (<http://plato.stanford.edu/entries/davidson/>), Last accessed: Mon, Jun 29, 2009.
- Mervis, C. B., Becerra, A. M. (2007). Language and communicative development in Williams syndrome. *Mental Retardation and Developmental Disabilities Research Reviews*, 13, 3–15.
- Nisbett, R., Wilson, T. (1977). Telling more than we can know: Verbal reports on mental processes. *Psychological Review*, 84, 231–59.
- Norbury, C., Bishop, D. V. M., Briscoe, J. (2001). Production of English finite verb morphology: A comparison of SLI and mild-moderate hearing impairment. *Speech Hearing Research*, 44, 165–178.
- Patterson K., Fushimi T. (2006). Organisation of language in the brain: Does it matter which language you speak? *Interdisciplinary Science Reviews*, 3, 201–16.
- Pinker, S. (1994). *The Language instinct: How the mind creates language*. New York: William Morrow and Co.
- Prinz, J. (2002). *Furnishing the mind: Concepts and their perceptual basis*. Cambridge, MA.: MIT Press.
- Prinz, J. J. (2006). Is the mind really modular? In R. Stainton, (Ed.), *Contemporary debates in cognitive science* (pp. 22–36), Oxford: Blackwell.
- Rumelhart, D. E., Smolensky, P., McClelland, J. L., and Hinton, G. E. (1986). Parallel distributed models of schemata and sequential thought processes. In McClelland, J. L. and Rumelhart, D. E., (Eds.), *Parallel Distributed Processing: Explorations in the Microstructure of Cognition*. Cambridge, MA.: MIT Press.
- Swindell, C. S., Greenhouse, J. B. (1988). Characteristics of recovery of drawing ability in left and right brain-damaged patients. *Brain and Cognition*, 7, 16–30.
- Vygotsky, L. S. (1962). *Thought and Language*. Cambridge, MA: MIT Press.
- Whorf, B. (1956). *Language, Thought and Reality*. New Jersey, Wiley.



# Postface

(Olaf Hauk, University of Cambridge)

The question as to how the mind creates “mental images” of concepts and memories, and how we use them in communication and thought, has fascinated philosophers for centuries. While it seems obvious that we acquire the meaning of objects, actions, words and abstract entities through our senses by interacting with our environment, the question as to how our bodies and environment shape the representation of meaning in mind and brain is still highly controversial in cognitive science. The last two decades have seen a number of exciting developments in this area. The concept of “embodiment”, i. e. the idea that sensory-motor systems can be part of abstract higher-level processes and representations, has penetrated a wide range of scientific fields. As demonstrated in these conference proceedings, the topic is discussed in literature studies, theoretical and computational linguistics, psycholinguistics, and cognitive neuroscience. From Chinese characters to metaphors and Shakespeare – the involvement of sensory-motor representations is part of the debate.

The analysis of every-day usage of language, the measurement of reaction times in laboratory tasks, or imaging the brain activity during language comprehension have provided us with a wealth of data on the role of sensory-motor knowledge in language. However, the excitement over the interdisciplinarity of this research area also comes at a cost: Are we all talking about the same things when we talk about embodiment or the role of sensory-motor systems? While for some researchers embodiment manifests itself in the different usage of verbs in metaphors, others require changes in brain activity in specific parts of the cortex. The conference “Sensory Motor Concepts in Language and Cognition” in Düsseldorf provided an ideal forum to discuss issues like these, and brought together world-leading experts from several relevant disciplines.

It became apparent that the abstract concept of embodiment is itself embodied in different ways in language corpora, reaction times and brain activation. We may not all ask the same questions. But connecting different theoretical approaches will help us to

*Olaf Hauk*

ask better questions, and introducing each other to different methodological approaches will help us answering them. Let us hope that our research will be embodied in more conferences like this in the future.



