



The Tomb of the Priests of Amun

*Burial Assemblages in
the Egyptian Museum of Florence*

GATE OF THE PRIESTS SERIES VOLUME I

Edited by
Rogério Sousa

CULTURE & HISTORY OF THE ANCIENT NEAR EAST

The Tomb of the Priests of Amun

Culture and History of the Ancient Near East

Founding Editor

M.H.E. Weippert

Editor-in-Chief

Jonathan Stökl

Editors

Eckart Frahm

W. Randall Garr

B. Halpern

Theo P.J. van den Hout

Leslie Anne Warden

Irene J. Winter

TOME XCVII

The titles published in this series are listed at *brill.com/chan*

Gate of the Priests

Edited by

Rogério Sousa
Alessia Amenta

VOLUME 1

The Tomb of the Priests of Amun

*Burial Assemblages in the Egyptian Museum
of Florence*

Edited by

Rogério Sousa



BRILL

LEIDEN | BOSTON



This is an open access title distributed under the terms of the CC BY-NC 4.0 license, which permits any non-commercial use, distribution, and reproduction in any medium, provided the original author(s) and source are credited. Further information and the complete license text can be found at <https://creativecommons.org/licenses/by-nc/4.0/>

The terms of the CC license apply only to the original material. The use of material from other sources (indicated by a reference) such as diagrams, illustrations, photos and text samples may require further permission from the respective copyright holder.

Funding acknowledgment: This work is financed by national funds through FCT - Foundation for Science and Technology, I.P, in the scope of the projects UIDB/04311/2020 and UIDP/04311/2020.



The Library of Congress Cataloging-in-Publication Data is available online at <https://catalog.loc.gov>
LC record available at <https://lcn.loc.gov/2018036424>



POLO MUSEALE
della TOSCANA

Typeface for the Latin, Greek, and Cyrillic scripts: "Brill". See and download: brill.com/brill-typeface.

ISSN 1566-2055

ISBN 978-90-04-38649-5 (hardback)

ISBN 978-90-04-38650-1 (e-book)

DOI 10.1163/9789004386501

Copyright 2019 by Rogério Sousa. Published by Koninklijke Brill BV, Leiden, The Netherlands. Koninklijke Brill BV incorporates the imprints Brill, Brill Nijhoff, Brill Schöningh, Brill Fink, Brill mentis, Brill Wageningen Academic, Vandenhoeck & Ruprecht, Böhlau and V&R unipress. Koninklijke Brill BV reserves the right to protect this publication against unauthorized use.

This book is printed on acid-free paper and produced in a sustainable manner.

Contents

Foreword IX

Christian Greco

Acknowledgments X

Figures XI

Presentation XIX

M. Cristina Guidotti

Shipping Documents and Correspondence Related to Lot v 1

M. Cristina Guidotti

PART 1

Catalogue

SECTION 1

Coffin Sets 19

Marianna Zarli and Rogério Sousa

Coffin Set of Djedmutiuesankh (A.15) 24

Coffin Set of Tauhenut (A.20) 114

Coffin Set of Khonsumes (A.22) 152

Outer Coffin of an Anonymous Man (A.56) 195

Coffin Set of an Anonymous Woman (A.60) 236

SECTION 2

Shabtis 323

Marianna Zarli

SECTION 3

Shabti-Boxes 469

M. Cristina Guidotti and Deborah Vannucci

PART 2***Essays***

The Reconstruction of the Burial Assemblages from Lot v 479

Marianna Zarli

Coffin Reuse in the 21st Dynasty: a Case Study of the Bab el-Gasus Coffins in the Egyptian Museum of Florence 492

Kathlyn M. Cooney

The Coffins of the Tomb of the Priests from an Art Historical Perspective: Lot v at the Egyptian Museum of Florence 515

Rogério Sousa

Bibliography 545

Index 553

Foreword

This impressive volume gives a complete overview of the burial assemblage from Bab el-Gasus housed at the Egyptian Museum in Florence. This book sets a method to approach the study of *disiecta membra* scattered in collections around the world. Thanks to the careful work coordinated by Dr. Sousa we are now able to fully understand Lot v preserved in Florence. Maria Cristina Guidotti collected all the shipping documents and the correspondence related to the arrival of the objects in Florence. Marianna Zarli and Rogério Sousa carried out a thorough analytical study of the coffins giving the archaeological context, dating, names and titles of the owner, analysis of the iconography, transliteration and translation of the inscriptions. The description of every coffin part is completed by drawings giving a schematic subdivision of the decoration, transcription of the texts, indispensable to detect the peculiarity of the signs, and extensive colour photographs. Marianna Zarli curated a chapter devoted to the 92 shabtis from Bab el-Gasus received by the Florence Museum. A careful description of the material, state of preservation, stylistic elements, typology (following Schneider), burial assemblage gives the reader all the elements to fully understand the *corpus* present in Florence. Drawings of the inscriptions and photographs complement the catalogue. Maria Cristina Guidotti and Deborah Vannucci studied the three shabti boxes that arrived with Lot v. This part is also complemented with extensive black and white photographs.

The volume ends with three important essays on the reconstruction of the burial assemblages (Marianna Zarli), coffin reuse in Lot v (Kathlyn Cooney), and coffin decoration of the Florence Lot (Rogério Sousa). These chapters allow us to understand the corpus, to discover the peculiarities and to reconstruct the context within which the objects should be studied. The method is set: the lots of Bab el-Gasus should not be studied or considered isolated artefacts. Their archaeological re-contextualisation is fundamental. Lot v becomes then a case study in which theories concerning re-use and iconographic development can be tested and understood.

This book is really the result of excellent team work. Rogério Sousa achieved a wonderful result: we have here not only a catalogue but a complete overview on all the recent research issues concerning Bab el-Gasus. This method should become paradigmatic for the future publications of all the *disiecta membra* of the Gate of the Priests.

Christian Greco

Director of the Museo Egizio in Turin
Turin

Acknowledgments

The idea of publishing a volume on the Lot v was born in 2014, during my stay at the Egyptian Museum of Florence, kindly hosted by its Director, M. Cristina Guidotti, aiming to document the objects originally found in the Tomb of the Priests of Amun at Thebes. This work is entirely owed to the enthusiasm with which M. Cristina Guidotti embraced this idea and to her endeavor in providing all the required conditions for the study and publication of the objects.

During this visit, I had the pleasure to meet Marianna Zarli, with whom I started the most fruitful cooperation, which has resulted in the work currently published. Her dedication was endless and I thank her for her precious and diligent work. The team also involved Deborah Vannucci, who, together with M. Cristina Guidotti, studied the shabti-boxes of the collection.

This book is also greatly indebted to the precious and generous contribution of Kathlyn Cooney, a member of the Gate of the Priests Project, who gave us the privilege of sharing her studies and documentation work and to Christian Greco, who kindly accepted our invitation to write the Foreword of this volume. I would like to express a vivid acknowledgement to René Van Walsem, who, besides remaining a constant source of inspiration, kindly revised the translations presented in this volume. My acknowledgement is extended to all the members of the Gate of the Priests Project, namely to Alessia Amenta, Luc Delvaux, Lara Weiss, Hélène Guichard, and Giovanna Prestipino, who have transformed the study on the 'yellow' coffins into such an exciting adventure.

I am also indebted to the editorial staff of Brill Publishers for their assistance and encouragement, as well as the team from the Centre of Classical and Humanistic Studies, from the University of Coimbra.

Rogério Sousa
Braga

Figures

Unless otherwise indicated, all photographs are by Fernando Guerrini. Copyrights of the photos: Ministero dei Beni e delle Attività Culturali e del Turismo, Polo Museale della Toscana.

- 1 Donation document from the Ministry for Public Education 12
- 2 Document number 7. List of finds donated 12
- 3 Card found inside the coffin (inv. no. 8522) 13
- 4 Invoice for transport expenses 14
- 5 Receipt for porterage services 15
- 6 Plan of the Tomb of the Priests. Drawing by Rogério Sousa after Niwiński (1988: table 1) and Daressy (1900: 147–148) 23
- 7 Coffin set (A.15) 24
- 8 Outer lid (A.15). Inscriptions. Drawing by Marianna Zarli 32
- 9 Outer lid (A.15). Inscriptions 1–2. Drawing by Rogério Sousa 33
- 10 Outer lid (A.15). Inscription 3. Drawing by Rogério Sousa 34
- 11 Outer lid (A.15). Inscriptions 4–11. Drawing by Rogério Sousa 35
- 12 Outer lid (A.15) 36
- 13 Outer lid (A.15). Headboard and upper section 37
- 14 Outer lid (A.15). Central panel 38
- 15 Outer lid (A.15). Central panel. Drawing by Rogério Sousa 39
- 16 Outer lid (A.15). Lower section 40
- 17 Outer lid (A.15). Footboard 41
- 18 Outer case (A.15). Inscriptions. Drawing by Marianna Zarli 52
- 19 Outer case (A.15). Inscriptions 1–2. Drawing by Rogério Sousa 53
- 20 Outer case (A.15). Inscriptions 3–9. Drawing by Rogério Sousa 54
- 21 Outer case (A.15). Inscriptions 10–17. Drawing by Rogério Sousa 55
- 22 Outer case (A.15). Inscription 18. Drawing by Rogério Sousa 56
- 23 Outer case (A.15). Headboard 57
- 24 Outer case (A.15). Left side 58
- 25 Outer case (A.15). Left side, upper section 59
- 26 Outer case (A.15). Left side, middle section 60
- 27 Outer case (A.15). Left side, lower section 61
- 28 Outer case (A.15). Right side 62
- 29 Outer case (A.15). Right side, upper section 63
- 30 Outer case (A.15). Right side, middle section 64
- 31 Outer case (A.15). Right side, lower section 65
- 32 Outer case (A.15). Interior decoration 66

- 33 Outer case (A.15). Interior decoration, headboard (above), detail of the floorboard (below) 67
- 34 Outer case (A.15). Interior decoration (floorboard) 68
- 35 Outer case (A.15). Interior decoration (detail of the floorboard) 69
- 36 Inner lid (A.15). Inscriptions. Drawing by Marianna Zarli 75
- 37 Inner lid (A.15). Inscriptions 1–2. Drawing by Rogério Sousa 76
- 38 Inner lid (A.15). Inscription 3. Drawing by Rogério Sousa 77
- 39 Inner lid (A.15) 78
- 40 Inner lid (A.15). Headboard and upper section 79
- 41 Inner lid (A.15). Headboard and upper section. Drawing by Rogério Sousa 80
- 42 Inner lid (A.15). Central panel (detail) 81
- 43 Inner lid (A.15). Central panel (detail) 82
- 44 Inner lid (A.15). Central panel. Drawing by Rogério Sousa 83
- 45 Inner lid (A.15). Footboard 84
- 46 Inner case (A.15). Inscriptions. Drawing by Rogério Sousa 93
- 47 Inner case (A.15). Inscriptions 1–2. Drawing by Rogério Sousa 94
- 48 Inner case (A.15). Inscriptions 3–4. Drawing by Rogério Sousa 95
- 49 Inner case (A.15). Headboard (above), footboard (below) 96
- 50 Inner case (A.15). Left side 97
- 51 Inner case (A.15). Left side, upper section 98
- 52 Inner case (A.15). Left side, lower section 99
- 53 Inner case (A.15). Right side 100
- 54 Inner case (A.15). Right side, upper section 101
- 55 Inner case (A.15). Right side, lower section 102
- 56 Inner case (A.15). Interior decoration 103
- 57 Inner case (A.15). Interior decoration. Headboard (above), footboard (below) 104
- 58 Inner case (A.15). Interior decoration. Headboard, floorboard and footboard. Drawing by Rogério Sousa 105
- 59 Mummy-cover (A.15). Inscriptions. Drawing by Marianna Zarli 109
- 60 Mummy-cover (A.15). Inscription 1. Drawing by Rogério Sousa 110
- 61 Mummy-cover (A.15) 111
- 62 Mummy-cover (A.15). Headboard and upper section 112
- 63 Mummy-cover (A.15). Central panel 113
- 64 Coffin set (A.20) 115
- 65 Lid (A.20). Inscriptions. Drawing by Marianna Zarli 120
- 66 Lid (A.20). Inscriptions 1–2. Drawing by Rogério Sousa 121
- 67 Lid (A.20). Inscriptions 3–10. Drawing by Rogério Sousa 122
- 68 Lid (A.20) 123
- 69 Lid (A.20). Headboard and upper section 124

- 70 Lid (A.20). Central panel 125
- 71 Lid (A.20). Lower section 126
- 72 Case (A.20). Inscriptions. Drawing by Marianna Zarli 132
- 73 Case (A.20). Inscriptions 1–14. Drawing by Rogério Sousa 133
- 74 Case (A.20). Headboard (above), footboard (below) 134
- 75 Case (A.20). Left side 135
- 76 Case (A.20). Left side, upper section 136
- 77 Case (A.20). Left side, middle section 137
- 78 Case (A.20). Left side, lower section 138
- 79 Case (A.20). Right side 139
- 80 Case (A.20). Right side, upper section 140
- 81 Case (A.20). Right side, middle section 141
- 82 Case (A.20). Right side, lower section 142
- 83 Mummy-cover (A.20). Drawing by Marianna Zarli 146
- 84 Mummy-cover (A.20). Inscription. Drawing by Rogério Sousa 147
- 85 Mummy-cover (A.20) 148
- 86 Mummy-cover (A.20). Headboard and upper section 149
- 87 Mummy-cover (A.20). Central panel 150
- 88 Mummy-cover (A.20). Lower section 151
- 89 Coffin set (A.22) 152
- 90 Lid (A.22). Inscriptions. Drawing by Marianna Zarli 161
- 91 Lid (A.22). Inscriptions 1–2. Drawing by Rogério Sousa 162
- 92 Lid (A.22). Inscription 3. Drawing by Rogério Sousa 163
- 93 Lid (A.22). Inscriptions 4–11 and 13–15. Drawing by Rogério Sousa 164
- 94 Lid (A.22) 165
- 95 Lid (A.22). Headboard and upper section 166
- 96 Lid (A.22). Headboard and upper section. Drawing by Rogério Sousa 167
- 97 Lid (A.22). Central panel 168
- 98 Lid (A.22). Lower section 169
- 99 Lid (A.22). Footboard 170
- 100 Case (A.22). Inscriptions. Drawing by Rogério Sousa 176
- 101 Case (A.22). Inscriptions 1–10. Drawing by Rogério Sousa 177
- 102 Case (A.22). Headboard (above), footboard (below) 178
- 103 Case (A.22). Left side 179
- 104 Case (A.22). Left side, upper section 180
- 105 Case (A.22). Left side, lower section 181
- 106 Case (A.22). Right side 182
- 107 Case (A.22). Right side, upper section 183
- 108 Case (A.22). Right side, lower section 184
- 109 Mummy-cover (A.22). Inscriptions. Drawing by Rogério Sousa 189

- 110 Mummy-cover (A.22). Inscriptions 1–4. Drawing by Rogério Sousa 190
- 111 Mummy-cover (A.22) 191
- 112 Mummy-cover (A.22). Headboard and upper section 192
- 113 Mummy-cover (A.22). Central panel 193
- 114 Mummy-cover (A.22). Lower section 194
- 115 Outer coffin (A.56) 196
- 116 Lid (A.56). Inscriptions. Drawing by Marianna Zarli 203
- 117 Lid (A.56). Inscriptions 1–2. Drawing by Rogério Sousa 204
- 118 Lid (A.56). Inscriptions 3–4. Drawing by Rogério Sousa 205
- 119 Lid (A.56). Inscriptions 5–7. Drawing by Rogério Sousa 206
- 120 Lid (A.56) 207
- 121 Lid (A.56). Headboard and upper section 208
- 122 Lid (A.56). Headboard and upper section. Drawing by Rogério Sousa 209
- 123 Lid (A.56). Central panel 210
- 124 Lid (A.56). Lower section 211
- 125 Lid (A.56). Footboard 212
- 126 Case (A.56). Inscriptions. Drawing by Rogério Sousa 222
- 127 Case (A.56). Inscriptions 1–2. Drawing by Rogério Sousa 223
- 128 Case (A.56). Inscriptions 3–4. Drawing by Rogério Sousa 224
- 129 Case (A.56). Inscriptions 5–16. Drawing by Rogério Sousa 225
- 130 Case (A.56). Headboard 226
- 131 Case (A.56). Left side 227
- 132 Case (A.56). Left side, upper section 228
- 133 Case (A.56). Left side, middle section 229
- 134 Case (A.56). Left side, lower section 230
- 135 Case (A.56). Right side 231
- 136 Case (A.56). Right side, upper section 232
- 137 Case (A.56). Right side, middle section 233
- 138 Case (A.56). Right side, lower section 234
- 139 Case (A.56). Interior decoration (left side) 235
- 140 Coffin set (A.60) 237
- 141 Outer lid (A.60). Inscriptions. Drawing by Rogério Sousa 243
- 142 Outer lid (A.60). Inscriptions 1–2. Drawing by Rogério Sousa 244
- 143 Outer lid (A.60). Inscriptions 3–5. Drawing by Rogério Sousa 245
- 144 Outer lid (A.60) 246
- 145 Outer lid (A.60). Headboard and upper section 247
- 146 Outer lid (A.60). Central panel 248
- 147 Outer lid (A.60). Central panel. Drawing by Rogério Sousa 249
- 148 Outer lid (A.60). Lower section 250
- 149 Outer lid (A.60). Lower section. Drawing by Rogério Sousa 251

- 150 Outer lid (A.60). Footboard 252
- 151 Outer case (A.60). Inscriptions. Drawing by Rogério Sousa 262
- 152 Outer case (A.60). Inscriptions 1–2. Drawing by Rogério Sousa 263
- 153 Outer case (A.60). Inscriptions 3–9. Drawing by Rogério Sousa 264
- 154 Outer case (A.60). Left side 265
- 155 Outer case (A.60). Left side, upper section 266
- 156 Outer case (A.60). Left side, middle section 267
- 157 Outer case (A.60). Left side, lower section 268
- 158 Outer case (A.60). Right side 269
- 159 Outer case (A.60). Right side, upper section 270
- 160 Outer case (A.60). Right side, middle section 271
- 161 Outer case (A.60). Right side, lower section 272
- 162 Outer case (A.60). Interior decoration (headboard) 273
- 163 Outer case (A.60). Interior decoration 274
- 164 Outer case (A.60). Interior decoration (left side) 275
- 165 Inner lid (A.60). Inscriptions. Drawing by Rogério Sousa 282
- 166 Inner lid (A.60). Inscriptions 1–2. Drawing by Rogério Sousa 283
- 167 Inner lid (A.60). Inscriptions 3–4. Drawing by Rogério Sousa 284
- 168 Inner lid (A.60). Inscriptions 5–16. Drawing by Rogério Sousa 285
- 169 Inner lid (A.60) 286
- 170 Inner lid (A.60). Headboard and upper section 287
- 171 Inner lid (A.60). Central panel 288
- 172 Inner lid (A.60). Central panel. Drawing by Rogério Sousa 289
- 173 Inner lid (A.60). Lower section 290
- 174 Inner lid (A.60). Lower section. Drawing by Rogério Sousa 291
- 175 Inner lid (A.60). Footboard 292
- 176 Inner case (A.60). Inscriptions. Drawing by Rogério Sousa 300
- 177 Inner case (A.60). Inscriptions 1–14. Drawing by Rogério Sousa 301
- 178 Inner case (A.60). Headboard (above), footboard (below) 302
- 179 Inner case (A.60). Left side 303
- 180 Inner case (A.60). Left side, upper section 304
- 181 Inner case (A.60). Left side, middle section 305
- 182 Inner case (A.60). Left side, lower section 306
- 183 Inner case (A.60). Right side 307
- 184 Inner case (A.60). Right side, upper section 308
- 185 Inner case (A.60). Right side, middle section 309
- 186 Inner case (A.60). Right side, lower section 310
- 187 Inner case (A.60). Interior decoration 311
- 188 Mummy-cover (A.60). Inscriptions. Drawing by Rogério Sousa 316
- 189 Mummy-cover (A.60). Inscriptions 1–2. Drawing by Rogério Sousa 317

- 190 Mummy-cover (A.60). Inscriptions 3–10. Drawing by Rogério Sousa 318
- 191 Mummy-cover (A.60) 319
- 192 Mummy-cover (A.60). Headboard and upper section 320
- 193 Mummy-cover (A.60). Central panel 321
- 194 Mummy-cover (A.60). Lower section 322
- 195 Shabtis of Isety 327
- 196 Shabtis of Isetemkhebi (Inscriptions). Drawing by Marianna Zarli 330
- 197 Shabtis of Isetemkhebi 330
- 198 Shabtis of Isetemkhebi (Inscriptions). Drawing by Marianna Zarli 333
- 199 Shabtis of Isetemkhebi 333
- 200 Shabtis of Amenhatpamesha (Inscriptions). Drawing by Marianna Zarli 336
- 201 Shabtis of Amenhatpamesha 336
- 202 Shabtis of Amenhotep (Inscriptions). Drawing by Marianna Zarli 339
- 203 Shabtis of Amenhotep 339
- 204 Shabtis of Ankhefenmut (Inscriptions). Drawing by Marianna Zarli 342
- 205 Shabtis of Ankhefenmut 342
- 206 Shabtis of Ankhefenkhonsu (Inscriptions). Drawing by Marianna Zarli 345
- 207 Shabtis of Ankhefenkhonsu 346
- 208 Shabti of Ankhefenkhonsu (Inscription). Drawing by Marianna Zarli 349
- 209 Shabti of Ankhefenkhonsu 349
- 210 Shabtis of Ankhesenmut (Inscriptions). Drawing by Marianna Zarli 351
- 211 Shabtis of Ankhesenmut 352
- 212 Shabti of Ankhesenmut (Inscription). Drawing by Marianna Zarli 354
- 213 Shabti of Ankhesenmut 354
- 214 Shabtis of Userhatmes (Inscriptions). Drawing by Marianna Zarli 357
- 215 Shabtis of Userhatmes 357
- 216 Shabtis of Bakenmut (Inscriptions). Drawing by Marianna Zarli 360
- 217 Shabtis of Bakenmut 360
- 218 Shabti of Paiefadger (Inscription). Drawing by Marianna Zarli 363
- 219 Shabti of Paiefadger 363
- 220 Shabtis of Pakharu (Inscriptions). Drawing by Marianna Zarli 366
- 221 Shabtis of Pakharu 366
- 222 Shabtis of Pasebakraenniut (Inscriptions). Drawing by Marianna Zarli 369
- 223 Shabtis of Pasebakraenniut 370
- 224 Shabtis of Padiamun (Inscriptions). Drawing by Marianna Zarli 373
- 225 Shabtis of Padiamun 373
- 226 Shabtis of Padiamun (Inscriptions). Drawing by Marianna Zarli 376
- 227 Shabtis of Padiamun 376
- 228 Shabtis of Meritamun (Inscriptions). Drawing by Marianna Zarli 379
- 229 Shabtis of Meritamun 379

- 230 Shabtis of Meritamun (Inscriptions). Drawing by Marianna Zarli 382
- 231 Shabtis of Meritamun 382
- 232 Shabtis of Meritamun (Inscriptions). Drawing by Marianna Zarli 385
- 233 Shabtis of Meritamun 385
- 234 Shabtis of Nesiamun (Inscriptions). Drawing by Marianna Zarli 388
- 235 Shabtis of Nesiamun 389
- 236 Shabtis of Nesiamenemope (Inscriptions). Drawing by Marianna Zarli 392
- 237 Shabtis of Nesiamenemope 392
- 238 Shabtis of Nesipaheran (Inscriptions). Drawing by Marianna Zarli 395
- 239 Shabtis of Nesipaheran 395
- 240 Shabtis of Nesipahernefer (Inscriptions). Drawing by Marianna Zarli 398
- 241 Shabtis of Nesipahernefer 398
- 242 Shabtis of Nesipakashuti (Inscriptions). Drawing by Marianna Zarli 401
- 243 Shabtis of Nesipakashuti 401
- 244 Shabtis of Nesimut (Inscriptions). Drawing by Marianna Zarli 404
- 245 Shabtis of Nesimut 404
- 246 Shabtis of Nesikhonsu (Inscriptions). Drawing by Marianna Zarli 407
- 247 Shabtis of Nesikhonsu 407
- 248 Shabtis of Nesitaudjatakhet (Inscriptions). Drawing by Marianna Zarli 410
- 249 Shabtis of Nesitaudjatakhet 410
- 250 Shabtis of Nesitanebtau (Inscriptions). Drawing by Marianna Zarli 413
- 251 Shabtis of Nesitanebtau 413
- 252 Shabtis of Henuttaui (Inscriptions). Drawing by Marianna Zarli 416
- 253 Shabtis of Henuttaui 417
- 254 Shabtis of Hori (Inscriptions). Drawing by Marianna Zarli 420
- 255 Shabtis of Hori 421
- 256 Shabtis of Heritubekhet (Inscriptions). Drawing by Marianna Zarli 424
- 257 Shabtis of Heritubekhet 424
- 258 Shabtis of Khaas (Inscriptions). Drawing by Marianna Zarli 427
- 259 Shabtis of Khaas 427
- 260 Shabtis of Khonsuemheb (Inscriptions). Drawing by Marianna Zarli 430
- 261 Shabtis of Khonsuemheb 430
- 262 Shabtis of Khonsumes (Inscriptions). Drawing by Marianna Zarli 433
- 263 Shabtis of Khonsumes 433
- 264 Shabtis of Shedsuamun 435
- 265 Shabti of Gautseshenu (Inscription). Drawing by Marianna Zarli 438
- 266 Shabti of Gautseshenu 438
- 267 Shabtis of Tabakenkhonsu (Inscriptions). Drawing by Marianna Zarli 441
- 268 Shabtis of Tabakenkhonsu 441
- 269 Shabtis of Tashedkhonsu (Inscriptions). Drawing by Marianna Zarli 445

- 270 Shabtis of Tashedkhonsu 445
- 271 Shabtis of Tashedkhonsu (Inscriptions). Drawing by Marianna Zarli 448
- 272 Shabtis of Tashedkhonsu 448
- 273 Shabtis of Taditmut (Inscriptions). Drawing by Marianna Zarli 451
- 274 Shabtis of Taditmut 451
- 275 Shabtis of Tjanefer (Inscriptions). Drawing by Marianna Zarli 454
- 276 Shabtis of Tjanefer 454
- 277 Shabtis of Tent-tau (Inscriptions). Drawing by Marianna Zarli 457
- 278 Shabtis of Tent-tau 457
- 279 Shabtis of Dikhonsuiri (Inscriptions). Drawing by Marianna Zarli 460
- 280 Shabtis of Dikhonsuiri 460
- 281 Shabtis of Djedmaatiuesankh (Inscriptions). Drawing by Marianna Zarli 463
- 282 Shabtis of Djedmaatiuesankh 463
- 283 Illegible shabti (Inscription). Drawing by Marianna Zarli 466
- 284 Illegible shabti 466
- 285 Shabti-box of Heritubekhet 473
- 286 Shabti-box (uninscribed) 474
- 287 Shabti-box of Dikhonsuiri 476
- 288 Lot v after Daressy 1907 479
- 289 Lot v after Niwiński 1988 480
- 290 Lot v after Aston 2009 481
- 291 Evidence for reuse in the Italian Lot 498
- 292 Coffin Reuse in Bab el-Gasus 499
- 293 Inv. 8523. Photo by Remy Hiramoto 511
- 294 Inv. 8524. Photo by Remy Hiramoto 511
- 295 Inv. 8525. Photo by Remy Hiramoto 512
- 296 Inv. 8526. Photo by Neil Crawford 512
- 297 Inv. 8527. Photo by Neil Crawford 513
- 298 Inv. 9530. Photo by Neil Crawford 513
- 299 Inv. 8528. Photo by Remy Hiramoto 514
- 300 Outer lid (A.56). Drawing by Rogério Sousa 541
- 301 Inner lid (A.15). Drawing by Rogério Sousa 542
- 302 Inner case—interior decoration (A.60). Drawing by Rogério Sousa 543
- 303 Outer lid (A.60). Drawing by Rogério Sousa 544

Presentation

The Egyptian Museum of Florence hosts one of the most important collections in Europe, and the second in Italy, after the Egyptian Museum in Turin.

A first group of Egyptian relics has been present in Florence since the 18th century in the Medici collections, and during the 19th century this was greatly increased by the Grand-duke of Tuscany Leopold II, who bought some collections and sponsored a scientific expedition to Egypt from 1828 to 1829. The expedition was led by Jean François Champollion and Ippolito Rosellini from Pisa, the father of Italian Egyptology.

The Egyptian Museum of Florence was established in 1855, and in 1880 was rearranged by the Egyptologist Ernesto Schiaparelli in the present location. Schiaparelli also significantly increased the Florentine Egyptian collections, thanks to his excavations and purchases made in Egypt, prior to his becoming Director of the Egyptian Museum of Turin in 1894.

The last group of relics acquired by the Egyptian Museum of Florence was made of donations from private citizens and scientific institutions; particularly noteworthy are the finds donated by the “G. Vitelli” Papyrological Institute of Florence from excavations in Egypt at El Hibeh and Antinoe between 1934 and 1939.

Now the Egyptian Museum of Florence holds over 14,700 finds, with materials ranging in date from the Prehistoric to the Coptic Periods: the most important objects are displayed throughout eleven rooms.

The Museum stores about 100 sarcophagi, most made of wood; many of these sarcophagi have never been published before. During the period in which Ernesto Schiaparelli was the director of the Florence Museum many new accessions occurred. Among them, one may notice the Lot v from Bab el-Gasus tomb. This bulk of artifacts, including coffins, shabtis and shabti-boxes, have never been studied nor photographed before.

Therefore I especially want to acknowledge my dear colleague Rogério Sousa, who, with his Gate of the Priests Project, has been able to fill in the gaps of knowledge of the coffins stored in the Egyptian Museum of Florence. Without him the present book would never have seen the light.

M. Cristina Guidotti

Director of the Egyptian Museum of Florence
Florence

Shipping Documents and Correspondence Related to Lot v

M. Cristina Guidotti

The tomb of Bab el-Gasus was discovered in January 1891 in the necropolis of Thebes. It was found in the area of Deir el-Bahari, close to the funerary temple of Queen Hatshepsut. The tomb consisted of burial chambers and galleries filled with several dozens of coffins: based on a first summary inventory of the material recovered, the tomb contained 153 coffins, 101 of which double (an inner coffin nested inside an outer coffin) and 52 single, in addition to countless funerary statuettes (shabti) with their boxes, statues of Ptah-Sokar-Osiris, funerary stelae, canopic jars and other grave goods belonging to the Priests of Amun of the 21st Dynasty. The French Egyptologist Georges Daressy compiled a first list of the entire material called A.List, in which however he assigned a number to a whole set of finds (often consisting of several coffins) belonging to just one person. Another list, called B.List, was drawn up by Eugène Grébaud and Urbain Bouriant, Director of the Archaeological Mission of the French Institute in Cairo. B.List contained many more numbers than Daressy's A.List since all the coffins nested inside one another were considered. Furthermore, once the material arrived in Cairo, a further number was assigned to it—the number of the *Journal d'Entrée* of the Giza Museum—before being donated to several nations worldwide. In fact, in 1893, the Egyptian Government decided to organize a lottery among the leading representatives of foreign nations who had arrived in Egypt to celebrate the new Khedive Abbas II Hilmi. The lottery prizes were the finds discovered in Bab el-Gasus. The amount of material was indeed so huge that the storage rooms of the Cairo Museum (then in Giza) were not able to accommodate all of the finds, but only the most important and better preserved objects.

Each lot consisted of 4 or 5 coffins and other finds from the tomb of Bab el-Gasus. A total of 17 lots were awarded to France, Austria, Turkey, Great Britain, Italy, Russia, Germany, Portugal, Switzerland, the United States, Holland, Greece, Spain, Sweden/Norway, Belgium, Denmark and the Vatican City State. Italy received Lot v and, given the excellent relations between Ernesto Schiaparelli, the (then) Director of the Egyptian Museum of Florence, and the Ministry for Public Education,¹ the finds assigned to Italy were sent to Florence.

¹ Several letters from the Ministry for Public Education were signed by C. Fiorilli, head of the

The Historical Archive of the Museum in Florence has preserved all the correspondence² relating to the donation of Lot v: 21 documents, dated between 9 March and 4 August 1893. The first document (Fig. 1) announces the donation and was received from the Ministry for Public Education:

Roma, 9 Marzo 1893. Oggetto. Antichità egiziane offerte in dono. Al Signor Direttore del Museo Egizio Prof. Cav. E. Schiaparelli Firenze.

s.E. il Ministro degli Affari Esteri mi ha trasmesso copia di una lettera diretta al R^o Agente diplomatico italiano al Cairo, dal Ministro egiziano degli Esteri, nella quale è detto che, per aderire alle istanze di molti egittologi^{sic}, il Governo Egiziano è venuto nella determinazione di donare ai principali Musei dell'Europa "sette collezioni di oggetti provenienti dalla scoperta detta Serie dei sacerdoti di Ammone, oggetti non necessari al Museo di Ghizet".

Una di queste sette collezioni è destinata pel Governo Italiano, ed io già ho pensato di inviarla, quando sarà giunta, al Museo diretto dalla s.v.

Di questa collezione il Governo Egiziano sta ora compilando un catalogo che sarà terminato entro il corrente mese.

In cambio di questo dono, il Governo Egiziano desiderrebbe^{sic} dal nostro Governo calchi in gesso di monumenti egizi che non trovansi nel Museo di Ghizet, ma che fanno parte delle raccolte italiane; ovvero pubblicazioni riguardanti la scienza egittologica.

Prego quindi la s.v. di volermi inviare, con la massima sollecitudine, un elenco di tutte le sue pubblicazioni, suggerendomi in pari tempo, tutti quei lavori di egittologia, pubblicati da italiani, e che Ella crede interessanti pel Governo Egiziano. Il Ministro.³

This letter speaks of seven lots, not of the 16 and then definitive 17 lots that were actually donated. Of interest is also the request to exchange the donation with moulds of Egyptian finds held in the Italian collections and with Egyptology publications.

After three days, Ernesto Schiaparelli hastily replied to the Minister's request. In the draft letter filed in the Florentine archives, the Director of the Museum excuses himself for the delay (!!) in responding and offers to make the

Ministry's cabinet, who had been coordinating the two administrative units of the Ministry since 1891 following the temporary abolition of the Directorate of Antiquities and Fine Arts.

2 The documents are preserved under the following title: "Museo Egizio 1 Carteggio Scientifico dal 1880 al 1894. Posizione A/1 Dono di antichità egiziane (1892-1893)".

3 The (then) Minister for Public Education was Ferdinando Martini.

mould of the bust of a Pharaoh⁴ and a replica of the famous chariot⁵ brought to the Museum by Ippolito Rosellini during the Franco-Tuscan Expedition, both on display at the Egyptian Museum of Florence. However, he also informed the Minister that he did not have sufficient funds. Schiaparelli attached a list of his publications (including the first volume of the catalogue⁶ of the Egyptian Museum of Florence and several articles) and a list of *Lavori di studiosi italiani di archeologia egiziana che potrebbero interessare il Governo Egiziano*. He also took the opportunity to ask the Minister to inquire with the Egyptian Government about adding some *campioni delle stoffe rinvenute a Deir el Bahri insieme alle Mummie dei faraoni*⁷ to the lot awarded to Florence. The following day, Schiaparelli wrote another letter to the Minister informing him of the costs needed to make the mould of the bust of the Pharaoh and on 18 March 1893 he sent a copy of his publications to the Minister.

The Ministry for Public Education sent two letters dated 22 March and 24 March to Schiaparelli, thanking him for the publications and informing him that the Egyptian Government had decided not to go ahead with the moulds.

Document number 7 is a letter dated 4 July 1893 received from the Ministry for Public Education. It is addressed to the *Direttore del R^o Museo Egiziano di Firenze* and is the most important of the entire correspondence. It contains two attachments. The first is a letter dated 16 June from Cairo and addressed to the Minister for Foreign Affairs in Rome. It contains details about the strange procedures followed to award the lots of material to the foreign countries that had attended the lottery in Egypt with their representatives. The letter explains that the draw had been carried out by the *Agente di Spagna, Decano del Corpo Diplomatico*, and that Lot v had been awarded to Italy, specifically to the *Museo Nazionale Egizio di Firenze*. The letter also specifies that some samples of fabrics discovered at Deir el-Bahari together with the pharaoh mummies would have been added to the Lot v material, as requested by Schiaparelli. The second attachment (Fig. 2) lists the material comprising the lot, which is reported below in full:

*Allegato alla lettera ministeriale del 4 Luglio 1893 N.° di prot. 8037
annessa al rapporto 16 giugno 1893 N.° 354/128*

4 Perhaps the bust probably depicting pharaoh Amasis (Egyptian Museum of Florence, inv. no. 5625) which had been recently acquired.

5 Chariot inv. no. 2678 of the Egyptian Museum of Florence.

6 Schiaparelli 1887.

7 Schiaparelli refers to the discovery of the first *cachette* of Deir el-Bahari in 1881 which contained above all the mummies of many kings of the New Kingdom.

Antichità egiziane comprese nel lotto N.° 5 toccato in sorte all'Italia, secondo la descrizione fattane dalla Direzione del Museo egiziano di Ghizeh Cinquième Lot

N.° 29691.15.16⁸

Très beau cercueil d'une chanteuse d'Ammon dont le nom est effacé partout.

La décoration du petit cercueil interieur est remarquable. Le disque entre les cornes d'une tête de taureau, qui porte au front un triangle noir; les autres taches sont disposées de manière à imiter à peu pres la forme du scarabée. La décoration extérieure du même cercueil est très intéressante.

À l'interieur du grand cercueil on remarque le disque contenant le signe de l'âme et l'oeil symbolique, posté, comme précédemment entre les cornes du taureau. Un serpent roulé sur lui même enveloppe un personnage à tête de lièvre, tenant de chaque main une plume d'autruche. La décoration extérieure est aussi très remarquable.

N.° 29701.60⁹

Grand Cercueil de la dame chanteuse d'Ammon "Ankheteninaut" Il avait appartenu à "Ankhefkhonsou" dont le nom est mal effacé. Intéressant.

N.° 29676¹⁰

Cercueil de Khonsoumès, scribe de la maison d'Ammon.

N.° 29644¹¹

Cercueil

N.° 20.25¹²

Cercueil

3 boites funéraires¹³

Statuettes funéraires¹⁴

N.° 1 Ank f₁₂^{sic} khonsou 2

" 2 Nessi ta neb taoui 2

8 Anonymous outer and inner coffins inv. nos. 8524 and 8528 of the Egyptian Museum of Florence.

9 The outer coffin of Ankhefkhonsu inv. no. 8523.

10 The coffin of the scribe of the dominion of Amun Khonsoumès inv. no. 8527.

11 Anonymous coffin inv. no. 8525.

12 Anonymous coffin inv. no. 8522.

13 Shabti-boxes inv. nos. 8529, 8530 and 8531 of the Egyptian Museum of Florence.

14 The number "2" written next to the names was written in blue pencil and clearly at a later date when checking the material. Two statuettes, therefore, had been donated for each person for a total of 92 shabtis. Regarding correspondence with the inventory numbers of the Egyptian Museum of Florence, reference may be made to the card of each shabti in this volume.

“	3	<i>Padouarer</i>	2 (?)
“	4	<i>Isit in kheb</i>	2 (?)
“	5	<i>Hat pa menfi amun</i>	2
“	6	<i>Tadoumant^{sic}</i>	2
“	7	<i>Ousorhatimes</i>	2
“	8	<i>Meritamun</i>	2
“	9	<i>Tetmant aus ankh</i>	2
“	10	<i>Amenhutep</i>	2
“	11	<i>Tashed khonsou</i>	2
“	12	<i>Isit</i>	2 (?)
“	13	<i>Ankh n maut</i>	2
“	14	<i>Meritamun</i>	2
“	15	<i>Heroub</i>	2
“	16	<i>Tent taoui</i>	2
“	17	<i>Dou khonsou ari</i>	2
“	18	<i>Bok n maut</i>	2
“	19	<i>Nessi ta ouza Khou</i>	2
“	20	<i>Padoua out ren ouit</i>	2
“	21	<i>Khaes</i>	2
“	22	<i>Pai fouzaro</i>	2
“	23	<i>Shedsouamun</i>	2 (?)
“	24	<i>Khonsoumes</i>	2
“	25	<i>Nespahashouti</i>	2
“	26	<i>Isit in kheb</i>	2
“	27	<i>Ankh f khonsou</i>	2
“	28	<i>Tabaken khonsou</i>	2
“	29	<i>Hent taoui</i>	2
“	30	<i>Teton mat ars ankh</i>	2
“	31	<i>Nesi amun ap.</i>	2
“	32	<i>Nesi mont</i>	2
“	33	<i>Ankh s n mat</i>	2
“	34	<i>Ankh n mat</i>	2
“	35	<i>Meritamun</i>	2
“	36	<i>Ta shed khonsou</i>	2
“	37	<i>Hori</i>	2
“	38	<i>Nesi amun</i>	2
“	39	<i>Pakhali</i>	2
“	40	<i>Ta nefer</i>	2
“	41	<i>Hatserhsi</i>	2
“	42	<i>Khonsou m heb</i>	2

“	43	<i>Nespa nefer her</i>	2
“	44	<i>Nesi khonsou</i>	2
“	45	<i>Padoua amen</i>	2
“	46	<i>Nesi pa hivar</i>	2

This highly important document provides the basis for identifying the coffins and the shabtis that arrived in Florence. It may be compared with all other existing lists, including Georges Daressy's original list (A.List), the list drawn up by Grébaut and Bouriant (B.List) and the one prepared by the Giza Museum. This list does not mention the fragments of fabric that Schiaparelli had asked for, which clearly did not belong to Lot v. It is to be noted also that a little card (Fig. 3) was found inside coffin no. 20.25 (inv. no. 8522), with the following text: 20.[25] *Cercueil en mauvais état, de travail très médiocre (momie à enlever). On peut seulement remarquer la scène d'Osiris se soulevant sur le lit pour la résurrection, en présence de Thot. N° 51*

Continuing the examination of the correspondence held at the Historical Archive of the Egyptian Museum of Florence related to the donation, after a letter that Schiaparelli wrote to the Minister, of interest is a letter from the Italian Embassy in Cairo (*Agenzia Diplomatica di s. M. il Re d'Italia*), dated 17 July 1893. The letter explains that the Lot v material had been packed by the Management of the Giza Museum¹⁵ and arranged in 8 crates for a total weight of 1,259 kg. The crates were expected to leave Alexandria on 21 July and reach Livorno on 28 July. The letter also confirms the presence of the fragments of fabric from Deir el-Bahari.

The correspondence then contains six letters regarding the journey of the crates sent via the *Vapore della Navigazione Generale Italiana* of Florio and Rubattino on a ship called *Persia*, exchanged between Ernesto Schiaparelli, the shipping agent P. Bonenfant, the *Navigazione Generale Italiana* and the prefect of Florence.

Documents numbers 16 (Fig. 4) and 17, dated 31 July and 4 August, consist of the invoice for transport expenses issued by the shipping agent P. Bonenfant and the declaration of entry of the crates arriving from Egypt at the Florence Customs Office, including a receipt (Fig. 5) for portage services. The following is reported in the declaration of entry: *Casse otto, lordo assieme kili milleduecentottanta, contenenti oggetti di collezione di antichità Egiziane donate dal Governo del Kédivé al R Governo Italiano e da questo destinate al R° Museo Egiziano di Firenze come da lettera Prefettura gabinetto N° 2040 del 30 Luglio ...*

¹⁵ As known, when packing the finds in Gizah for their shipping, mistakes were made when matching some coffins. The letter is signed by L. (Licurgo) Macciò.

The last documents of the correspondence held at Florence are all dated 4 August 1893: four letters written by the director of the Egyptian Museum, Ernesto Schiaparelli, to the Royal Diplomatic Agent of His Highness the King of Italy in Egypt, to the Consul of Italy in Alexandria, to the Prefect of Florence and to the Minister for Public Education, respectively. In all four letters, which have very similar content, Schiaparelli announces that on the same day—4 August—the 8 crates from Egypt had arrived. The text of the fourth letter, addressed to the Minister, is reported below:

Firenze, 4 Agosto 1893. OGGETTO Ricevimento delle antichità donate dal Governo egiziano. A S.E. il Ministro della Pubblica Istruzione.

Mi affretto ad annunziare a V.E. che oggi stesso sono qui pervenute le antichità donate dal Governo Kediviale a quello di Sua Maestà, e dall'E.V. destinate a questo Museo egiziano.

Senza ritardo procedetti a un minuto riscontro delle medesime coll'Elenco che mi fu precedentemente convocato dall'E.V. colla sua lettera del 4 Luglio p.p. (Num. di part. 8037), e constatai che nessun oggetto mancava di quelli indicati nell'Elenco stesso. Rinvenni pure i campioni di tele e le ghirlande aggiunte ulteriormente dietro la pressione del R. Agente Diplomatico d'Italia Comm. Macciò.

Le antichità suddette erano contenute in otto grandi casse ben confezionate, e giunsero a questo Museo in perfetto stato, eccettuati alcuni gruppi di ghirlande di fiori intrecciati con foglie di persea, che di loro natura immensamente fragili, si scomposero e si frantumarono durante il viaggio. Se non per vera e propria importanza archeologica, certo per il numero e per la mole loro, le antichità inviateci dal Governo egiziano costituiscono un dono cospicuo e rappresentano per queste collezioni un notevole incremento.

Ho disposto per il pagamento di una nota di spese per sbarco, franco di porto, ecc. da Livorno a questo Museo per la somma di L.110,35: delle rimanenti spese di porto dal Cairo fino a Livorno io non ebbi finora alcuna partecipazione, per cui suppongo che, qualora non siano state fatte dallo stesso Governo egiziano, devono essere state sostenute dalla R. Agenzia Diplomatica al Cairo o dal R. Consolato di Alessandria.

Il Direttore Ernesto Schiaparelli

When referring to the material received, Schiaparelli not only talks about the samples of fabric that had been previously requested but also about garlands of flowers and leaves, of which there had been no previous mention.

Schiaparelli started to draw up the inventory of material that had arrived from Egypt immediately. In volume v of the handwritten catalogue regarding

the material of the Egyptian Museum of Florence, inventory number 8521 reads as follows: *Sarcophago in legno stuccato e dipinto*, with provenance *Deir el Bahri, tomba dei sacerdoti di Ammone a Tebe (Dono del Governo egiziano)*. Actually, this was not a true coffin, but a mummy-cover, yet the following inventory numbers (8522–8528) report the following description: *sette sarcofaghi come sopra*. Schiaparelli did not inventory the other three mummy-covers and evidently left them inside their coffins, which over time, however, were removed. It was not until the 1930s and 1940s that Giuseppe Botti, curator of the Egyptian Museum of Florence, checked the material and assigned numbers 9476, 9530 and 9534 to the three mummy-covers that had not been inventoried. Thanks to the study and research carried out by Marianna Zarli, it has been possible to locate the original provenance of some of them and to match them with their respective coffins, which even Botti had no longer been able to identify.

The table below provides an overview of the situation on the basis of the documentation available at the Florence Museum and on the basis of Zarli's study.¹⁶

	Object	Inventory number	A list number	B list number	Giza Museum number	Name of coffin owner
1	Outer coffin	8523	60	–	29701	Ankhefenkhonsu
	Inner coffin	8526	60(?)	–	–	Chantress of Amun Anonymous
	Mummy-cover	8521	60	–	–	Chantress of Amun Ankhesenmut
2	Outer coffin	8524	15	16	29691	Chantress of Amun anonymous
	Inner coffin	8528	15	16	29691	Chantress of Amun anonymous
	Mummy-cover	9534	15	16	29691	Chantress of Amun anonymous
3	Inner coffin	8522	20	25	–	Chantress of Amun anonymous
	Mummy-cover	9476	20	25(?)	–	Anonymous

¹⁶ The table is freely taken from the table reported in Marianna Zarli's degree thesis at page 479.

(cont.)

	Object	Inventory number	A list number	B list number	Giza Museum number	Name of coffin owner
4	Inner coffin	8527	22	29	29676	Scribe of the Estate of Amun Khonsumes
	Mummy-cover	9530	22	29	29731	Anonymous
5	Outer coffin	8525	56	77	29644	Priest of Amun anonymous

Schiaparelli also assigned inventory numbers 8529, 8530 and 8531 to the three shabti-boxes; number 8532 to the garlands of flowers and leaves; and numbers 8533, 8534 and 8535 to the three fragments of fabric without specifying that they had been taken from the Royal Cache (the one containing the mummies of the pharaohs) and not from the Bab el-Gasus. Inventory numbers 8536 to 8627 were assigned to the shabtis, for a total of 92 shabtis. However, during the checks carried out by Giuseppe Botti, numbers 8590 and 8617 were recorded as lost: actually, the two shabtis were not lost but had been mistaken for other shabtis, which were effectively lost.¹⁷

Regarding the garlands of flowers and leaves under inventory number 8532,¹⁸ it is difficult to say if they were taken from the Royal Cache or from Bab el-Gasus, since neither the correspondence nor volume v of the handwritten catalogue provide details. What appears to be certain is the provenance of the three fragments of fabric from the tomb discovered in Deir el-Bahari in 1881, the tomb of the mummies of the pharaohs. This fact is repeated several times in the letters, although the inscriptions and dating of the finds raise some doubts on this point.¹⁹

To conclude, a table is reported below with the list of documents that comprise the correspondence related to the donation, held at the Historical Archive of the Egyptian Museum of Florence.

17 Inv. nos. 8566 and 8567. These shabtis are now found, but almost completely destroyed.

18 See Guidotti 2015, 128.

19 See, for example, inv. no. 8535, with the inscription referring to another fabric held at the Egyptian Museum of Florence, dating back to the Middle Kingdom: Guidotti 2009, 20 and 29 no. 15.

	Date	Sender	Recipient	Subject matter of document
1	9 March 1893	Ministry for Public Education	Director of Egyptian Museum, Ernesto Schiaparelli	Announcement of donation
2	12 March 1893	Royal Archaeological Museum of Florence	Minister for Public Education	Organisation of moulds and list of publications
3	13 March 1893	Royal Archaeological Museum of Florence	Minister for Public Education	Letter communicating costs for making moulds
4	18 March 1893	Royal Archaeological Museum of Florence	Minister for Public Education	Submission of publications with attached list
5	22 March 1893	Ministry for Public Education	Director of Egyptian Museum	Decision not to go ahead with the moulds
6	24 March 1893	Ministry for Public Education	Director of Egyptian Museum	Letter of thanks for submission of publications
7	4 July 1893	Ministry for Public Education	Director of Egyptian Museum	Submission of letter from Cairo and list of finds donated
8	5 July 1893	Royal Archaeological Museum of Florence	Minister for Public Education	Return of original letter from Cairo
9	17 July 1893	Diplomatic Agency of His Highness the King of Italy—Cairo	Director of Egyptian Museum Ernesto Schiaparelli	Announcement of packaging of 8 crates containing the finds
10	22 July 1893	Royal Egyptian Museum of Florence	Agent of <i>Navigazione Generale Italiana</i> —Livorno	Request to deliver crates to shipping agent
11	22 July 1893	Royal Egyptian Museum of Florence	P. Bonenfant <i>Spedizioniere</i> —Livorno	Request to deliver crates in Florence
12	24 July 1893	<i>Navigazione Generale Italiana</i> —Livorno	Director of Egyptian Museum of Florence	Confirmation of departure of crates
13	25 July 1893	P. Bonenfant <i>Spedizioniere</i> —Livorno	Director of Royal Egyptian Museum—Florence	Confirmation of departure of crates
14	29 July 1893	P. Bonenfant <i>Spedizioniere</i> —Livorno	Royal Egyptian Museum—Florence	Confirmation of arrival of crates
15	30 July 1893	Prefecture of Florence	Ernesto Schiaparelli, Director of Egyptian Museum	Submission of letter from Italian Consul in Alexandria of Egypt
16	31 July 1893	P. Bonenfant <i>Spedizioniere</i> —Livorno	Royal Egyptian Museum—Florence	Invoice for transport expenses

(cont.)

	Date	Sender	Recipient	Subject matter of document
17	4 August 1893	Florence Customs Office	Director of Royal Egyptian Archaeological Museum	Delivery note with declaration of goods and receipt for portorage services
18	4 August 1893	Royal Archaeological Museum of Florence	Royal Diplomatic Agent of His Highness the King of Italy—Cairo	Letter communicating arrival of all the material and checks
19	4 August 1893	Royal Archaeological Museum of Florence	Royal Consul of Italy—Alexandria	Letter communicating arrival of all the material and thanks
20	4 August 1893	Royal Archaeological Museum of Florence	Prefect of the Province of Florence	Letter communicating arrival of all the material
21	4 August 1893	Royal Archaeological Museum of Florence	Minister for Public Education	Letter communicating arrival of all the material and checks

Of the material received from the tomb of Bab el-Gasus, only the coffins under inventory numbers 8524, 8528 and 8527 and the mummy-covers under inventory numbers 8521, 9534 and 9530 are on display in Room VIII of the Egyptian Museum of Florence. The decision regarding which coffins to display was made in 2015 during the restyling of the Historical Room VIII of the Museum, during an important event in which the Museum played a leading role: the organization of the XI International Congress of Egyptologists.

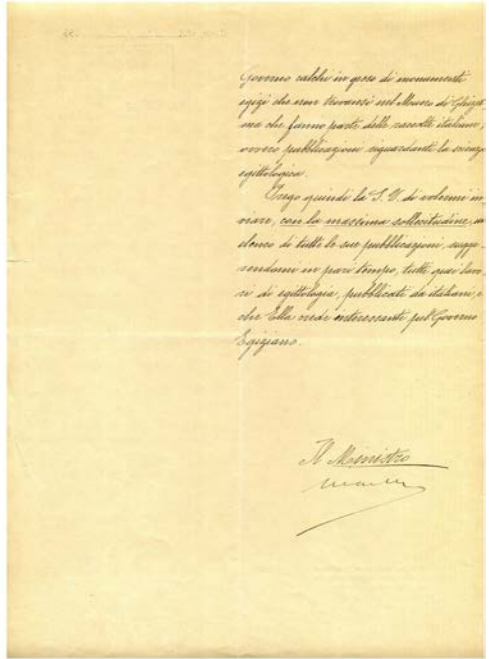
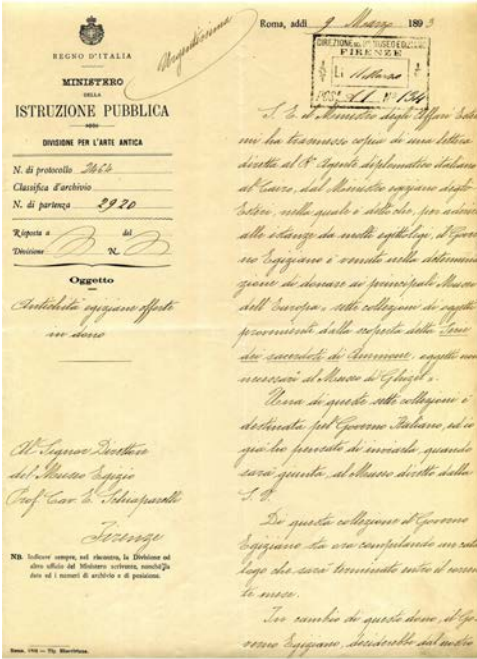

FIGURE 1 Donation document from the Ministry for Public Education

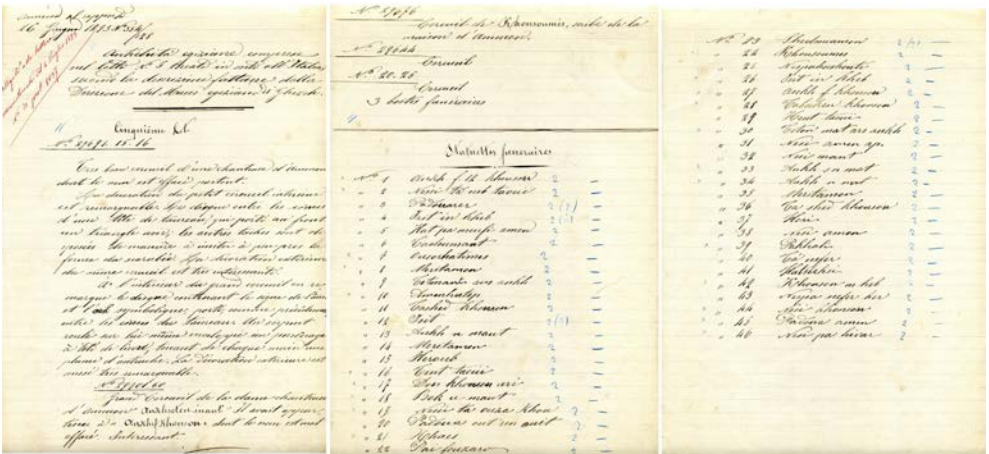

FIGURE 2 Document number 7: list of finds donated

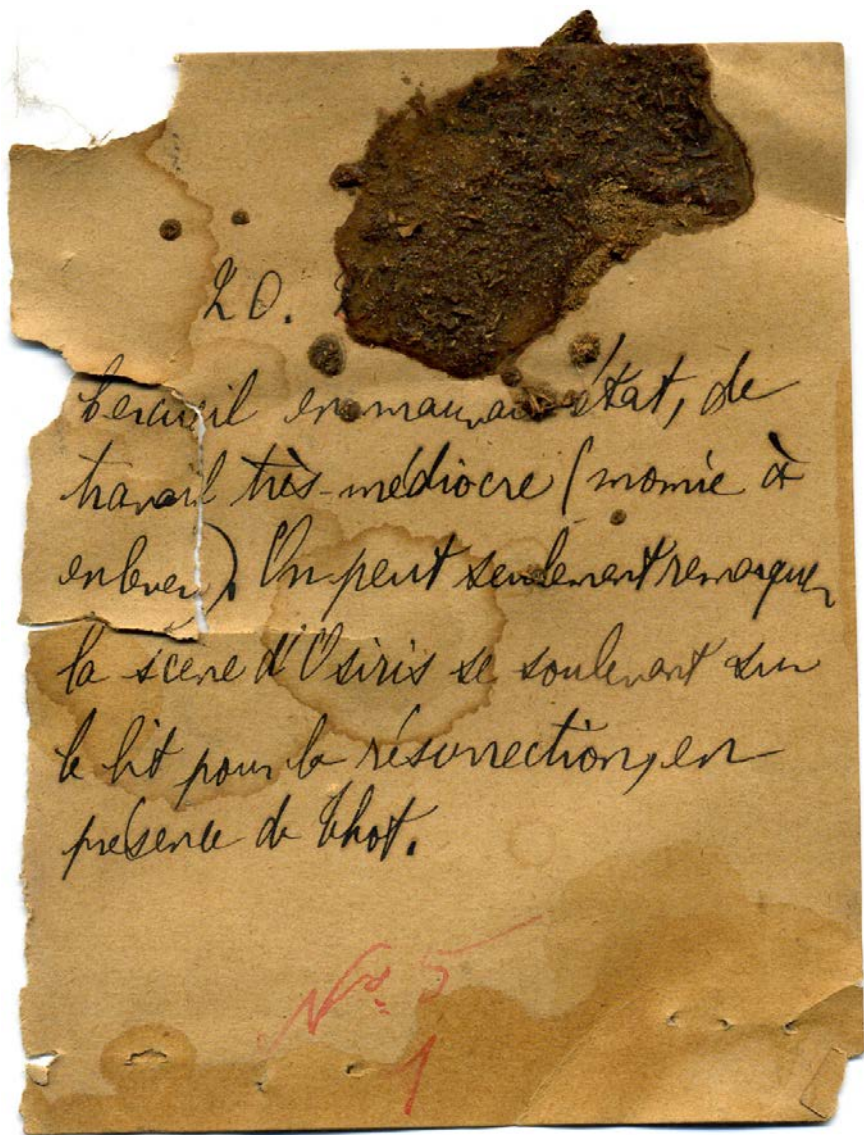

FIGURE 3 Card found inside the coffin—inv. no. 8522

Casa Fondata nel 1858

P. BONENFANT
Spedizioni
COMMISSIONI, RAPPRESENTANZE, INCASSI

LIVORNO

DIREZIONE DEL MUSEO EGIZIANO
FIRENZE

L. Agostini

POS. 11 N.º 401

Livorno, li 31 Luglio 1893

Spett. R. Maresca Egiziano
Firenze

Vinno d'india n.º 1.º

Per le mie spese ammontando fino L. 66.15

Per la mia spesa ammontando fino L. 66.15

Ma rassicurando per la continuazione dei pregiati vostri ordini e
fruttando vi presento i miei sinceri saluti

N.º 43582

Marche	N.º	P.º	Contenuto	Spese
1	100	} C. Com. Non V. D.		Porto Livorno 9.30
2	79			Porto Livorno
3	104			Porto Livorno
4	112			Porto Livorno
5	115			Porto Livorno
6	115			Porto Livorno
7	115			Porto Livorno
8	115		Porto Livorno	
9	115		Porto Livorno	
10	115		Porto Livorno	
11	115		Porto Livorno	
12	115		Porto Livorno	
13	115		Porto Livorno	
14	115		Porto Livorno	
15	115		Porto Livorno	
16	115		Porto Livorno	
17	115		Porto Livorno	
18	115		Porto Livorno	
19	115		Porto Livorno	
20	115		Porto Livorno	
21	115		Porto Livorno	
22	115		Porto Livorno	
23	115		Porto Livorno	
24	115		Porto Livorno	
25	115		Porto Livorno	
26	115		Porto Livorno	
27	115		Porto Livorno	
28	115		Porto Livorno	
29	115		Porto Livorno	
30	115		Porto Livorno	
31	115		Porto Livorno	
32	115		Porto Livorno	
33	115		Porto Livorno	
34	115		Porto Livorno	
35	115		Porto Livorno	
36	115		Porto Livorno	
37	115		Porto Livorno	
38	115		Porto Livorno	
39	115		Porto Livorno	
40	115		Porto Livorno	
41	115		Porto Livorno	
42	115		Porto Livorno	
43	115		Porto Livorno	
44	115		Porto Livorno	
45	115		Porto Livorno	
46	115		Porto Livorno	
47	115		Porto Livorno	
48	115		Porto Livorno	
49	115		Porto Livorno	
50	115		Porto Livorno	
51	115		Porto Livorno	
52	115		Porto Livorno	
53	115		Porto Livorno	
54	115		Porto Livorno	
55	115		Porto Livorno	
56	115		Porto Livorno	
57	115		Porto Livorno	
58	115		Porto Livorno	
59	115		Porto Livorno	
60	115		Porto Livorno	
61	115		Porto Livorno	
62	115		Porto Livorno	
63	115		Porto Livorno	
64	115		Porto Livorno	
65	115		Porto Livorno	
66	115		Porto Livorno	
67	115		Porto Livorno	
68	115		Porto Livorno	
69	115		Porto Livorno	
70	115		Porto Livorno	
71	115		Porto Livorno	
72	115		Porto Livorno	
73	115		Porto Livorno	
74	115		Porto Livorno	
75	115		Porto Livorno	
76	115		Porto Livorno	
77	115		Porto Livorno	
78	115		Porto Livorno	
79	115		Porto Livorno	
80	115		Porto Livorno	
81	115		Porto Livorno	
82	115		Porto Livorno	
83	115		Porto Livorno	
84	115		Porto Livorno	
85	115		Porto Livorno	
86	115		Porto Livorno	
87	115		Porto Livorno	
88	115		Porto Livorno	
89	115		Porto Livorno	
90	115		Porto Livorno	
91	115		Porto Livorno	
92	115		Porto Livorno	
93	115		Porto Livorno	
94	115		Porto Livorno	
95	115		Porto Livorno	
96	115		Porto Livorno	
97	115		Porto Livorno	
98	115		Porto Livorno	
99	115		Porto Livorno	
100	115		Porto Livorno	
Totale				L. 66.15

AVVERTENZE. — Il Peso lordo indicato di sopra è conforme a quello avviato dal Mittenti e da me scrupolosamente controllato. — La buona condizione interna è confermata dalla polizza di carico. — Per cui incombe ai Sigg. Destinatari di controllare accuratamente lo stato della merce in arrivo ed in caso di dedizione di peso, di acondizionatura o di avaria di fare le loro riserve con constatazione legale, caso contrario non accetterò nessun reclamo in merito. — Come d'uso, la rottura degli oggetti fragili come pure la dispersione dei liquidi non sono garantiti. — Non cupro assicurazione di qualsiasi sorta senza l'ordine preciso degli interessati.

Vostro silenzio mi servirà di ricevuta.

FIGURE 4 Invoice for transport expenses

DOGANA RICEVUTA PER FACCHINAGGI
DI FIRENZE

L'anno 1893, addi 4. 8.

N. 829, ha pagato i seguenti diritti di Facchinaggio per i seguenti Colli che si levano di Dogana, come da Bolletta di N.

Quantità dei Colli	Peso	QUALITÀ DELLA MERCE	Diritto	
			Tariffato	Pagato
8.	100.			
	39.		2.	1.40
	109.		2.	2.70
	109.		2.	6
	265.		2.	10
	117.			
	276			
	230			

L' INCARICATO DELLA RISCOSSIONE
Sturani

FIGURE 5 Receipt for porterage services

PART 1
Catalogue



SECTION 1

Coffin Sets

Marianna Zarli and Rogério Sousa



Introductory Notes

In Lot v were included three outer coffins, four inner coffins and four mummy-covers forming four burial assemblages. In this Catalogue, the order of presentation of the burial assemblages will follow the numbers recorded by Georges Daressy, which have the advantage of indicating the position of each coffin set within the tomb. In each object the layout of the iconography and the inscriptions are described separately. The iconography is presented according to the following topography:¹

- **Headboard:** On the lid, this area includes the head and the wig, while on the case, it is composed of a tripartite panel;
- **Upper section:** On the lid this section is delimited by the contour of the fore-arms or the floral collar. On the case this section is bounded by the contour of the arms;
- **Central panel:** This tableau only figures on the lid and it is composed by a variable number of registers;
- **Lower section:** On the lid, the lower section displays two or three longitudinal partitions. On the case, the lower section extends from the elbows to the footboard;
- **Footboard:** The lid is normally arranged in three partitions. On the case, this area is seldom decorated.

The interior of the case also reveals an architectonic layout suggesting the interior decoration of a shrine:

- **Headboard:** Decorated as the ‘ceiling’ of the ‘shrine’;
- **Sides:** The decoration involves several registers suggesting the side-walls of a shrine;
- **Floorboard:** Large iconographic composition arranged in several registers. This section is decorated as the rear wall of a shrine;
- **Footboard:** Normally undecorated, it is seen as the ground of the shrine. It seldom features cryptographic compositions.

References to this topography take into account the anthropomorphic shape of the coffin set. As such, references to left/right are mentioned according to the perspective of the deceased. When describing vignettes, we consider them as autonomous pictorial units, and references to left and right take into account the perspective of the viewer.

¹ This view was developed from the concept of architectonization formulated by René Van Walsem. See Van Walsem 1997. See also Sousa 2017a and Sousa 2017b.

In our text, the avian manifestation of the deceased is described as human. When explicit identification of deities is found, these are described as human-shaped deities, regardless of their actual animal manifestation.

The textual description of each object is complemented with visual documentation. Critical references of these objects are further developed in Part 2 of this volume.

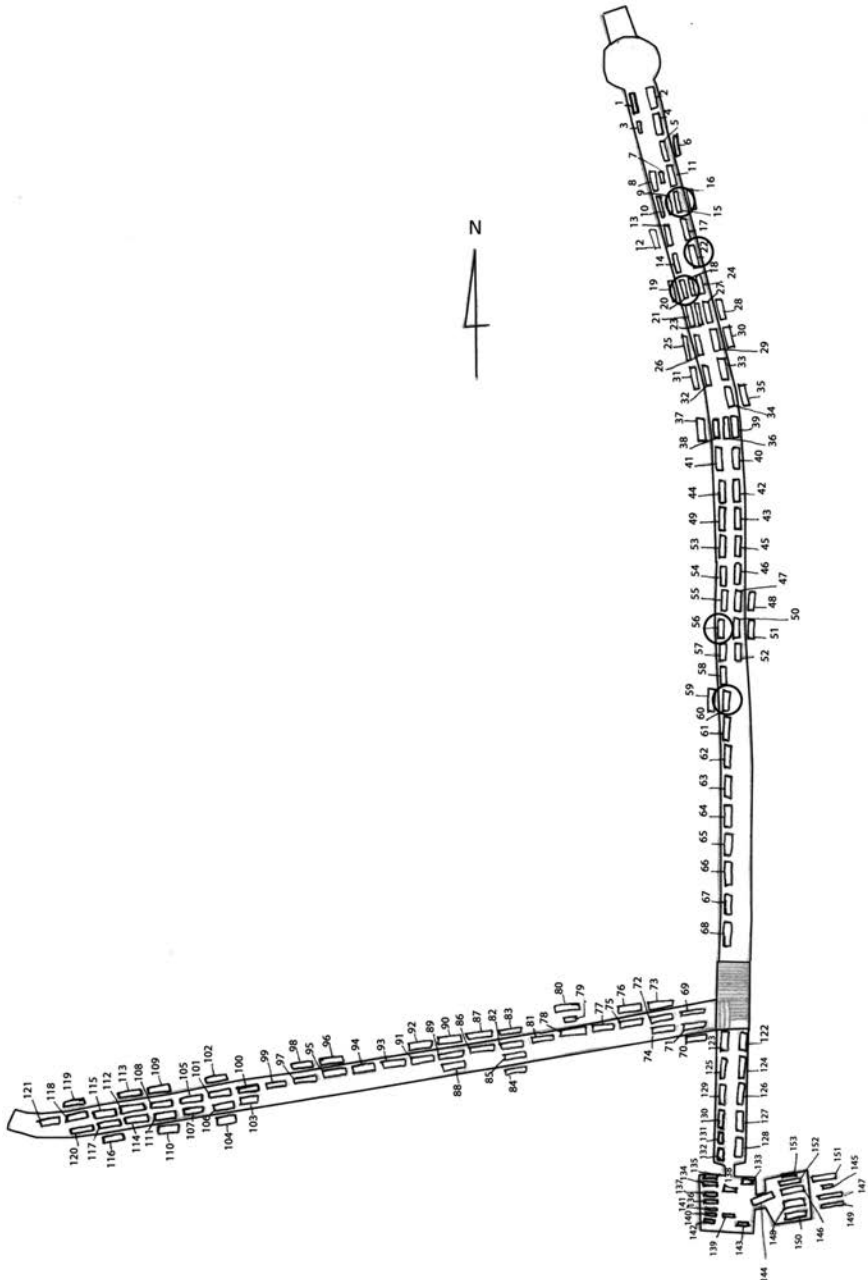

FIGURE 6 Plan of the Tomb of the Priests. The coffin sets kept in the Egyptian Museum of Florence are circled.

Coffin Set of Djedmutiuesankh (A.15)

Summary description: Outer anthropoid coffin (1–2), inner anthropoid coffin (3–4) and mummy-cover (5), all anonymous.

Archaeological context and dating: The coffin set was found in the main gallery of Bab el-Gasus, next to the eastern wall. The scheme of decoration detected on the objects of this coffin set dates from the late 21st Dynasty. The burial assemblage included an Osiris shroud, a large pebble on the chest and eight linen garments wrapped around the body.¹

Name and titles of the owner: The objects of this burial assemblage remained anonymous. However, a blank space was left by the craftsmen to be later inscribed with the name of the owner. This procedure is detected on the lid of the outer coffin (Inscription 3), on the lid of the inner coffin (Inscription 3), on the case of the inner coffin (Inscriptions 1–2) and on the mummy-cover (Inscription 1). The texts present generic titles such as “*Mistress of the house*” and “*Chantress of Amun-Re, king of the gods*”. Daressy reports that the name Djedmutiuesankh was found on the shroud.²



FIGURE 7 Coffin set (A.15)

1 Aston 2009, 166 n. TG 688.

2 Daressy 1907, 22–23.

1. Outer Lid

Museum inventory number: 8524

Length: 204 cm; Width (max): 67 cm

Wood, plaster, paint and varnish.

Decorated with multicoloured paintwork and occasional use of moulded plaster.

The reverse side is undecorated, as well as the underside of the footboard.

The hands are carved in wood and attached to the lid.

The object presents several cracks. The paint has faded away on the wig and on the left side (upper section and lower section). The headboard and the footboard are also affected by severe cracks.

The object was restored in the workshops of the Egyptian Museum of Florence during the years 1957–1958.¹

Iconography

Headboard

A large multicoloured headband decorated with lotus petals and geometrical motifs adorns the tripartite wig (blue). A bunch of three lotus flowers hangs down from the crown of the head over the forehead. The face is angular and muscular. The skin is yellow and the contour of the eyes and eyebrows is black. The pupils (black) are painted against a white background. A red line is traced above the eye to suggest the eye-lid. The earrings lost their pictorial decoration. Floral bindings adorn the lappets of the wig displaying a double band decorated with a pearl-beaded motif (Fig. 13).²

Upper Section

The breasts (moulded in plaster) figure below the lappets of the wig featuring small rosettes to suggest the nipples. The hands are open, painted yellow and crossed over the chest. The elbows are decorated with a large multicoloured lotus flower but the forearms are hidden under the floral collar (Fig. 13).

The area comprised between the lappets of the wig presents a short collar decorated with monochromatic transversal bands (red and green).

1 Bosticco 1958, 10.

2 Perhaps mandrake flowers. See Sousa 2018b, 59.

The floral collar covers the torso and part of the abdomen, displaying eight bands decorated with a variety of patterns such as checkered motifs (2nd, 4th, 6th and 8th bands), persea-tree buds (3rd, 7th), lotus petals (5th band) and lotus intertwined with acacia flowers and persea-tree flowers (1st band).³

A large pectoral is depicted on the chest featuring the solar-headed heart amulet flanked by sacred cobras (also equipped with solar disks). The heart amulet (moulded and painted in black) is inscribed with a column of hieroglyphs (yellow) reading “*Osiris, foremost of the beautiful West*”. The object hangs from a necklace (red).⁴

Central Panel

The central panel is composed of four registers displaying large winged deities (1st and 3rd registers) or symmetrical compositions (2nd and 4th registers). The tableau is bounded by longitudinal (Inscriptions 1–2) and transversal (Inscriptions 4–5) bands of text. Some of the motifs of the composition are moulded in plaster to suggest relief, such as the scarabs, the enthroned gods, the *hwt*-thrones, the large avian deity and some of the liminal elements.

The first register comprises a large winged solar disk flanked by sacred cobras. The wings are outstretched towards both sides of the lid (Figs. 14–15).

The second register shows a symmetrical composition. The nuclear block features a sacred scarab holding up a solar disk in its forelegs and displaying the *shen*-ring between the hind legs. The solar disk is flanked by cobras. The scarab rises from the *nebu*-sign flanked by *shen*-rings. This composition is flanked by centrifugal blocks, each one including an enthroned mummiform Osiris grasping the royal scepters. The god has curled beard and wears a lotus bud on his head. Behind the throne figure sacred cobras wearing the *hedjet*-crown with large *tjet*-signs hanging from their necks. On both sides of the composition, figure centripetal blocks featuring a kneeling goddess outstretching her wings towards Osiris. She wears the *West*-sign on her head, and grasps a feather. The *udjat*-eye and the *nefer*-sign figure under her wings.

In the third register figures a large falcon outstretching its wings towards both sides of the lid. The deity grasps *shen*-rings with its claws and it is crowned with a solar disk with two pending cobras. Its long tail is projected downwards

3 See the floral patterns in Sousa 2018b, 59, 97.

4 This motif is also found in the outer coffin of Ikhy, found in Bab el-Gasus and now kept in the Vatican Museums (n. 25035; Gasse 1996, 81–97 e Tavv. XIII–XVIII). On the significance of this amulet see Sousa 2011 and Sousa 2007.

to the fourth register.⁵ A frieze of liminal elements (vultures, cobras, *shetyt*-shrines) is displayed above the wings of the falcon forming a symmetrical centripetal composition.

The fourth register features a symmetrical composition. The nuclear block shows a solar disk flanked by cobras rising from the *nebu*-sign. This composition is flanked by centrifugal blocks showing kneeling gods grasping the *heqa*-scepter. Each god has divine beard and wears a long wig. The register is completed with centripetal blocks featuring a kneeling goddess outstretching her wings towards the mummiform god. She is crowned with the *modius* and grasps a feather. The *udjat*-eye and the *nefer*-sign figure under her wings.

Along the edges of the composition, additional blocks form three registers. From top to bottom one detects an enthroned mummiform god (facing inwards) wearing a feather on his head. He grasps the royal scepters and the throne rests on a *heb*-bowl and a reed mat. A human-headed *ba*-bird figures above, raising his arms towards the *shetyt*-shrine. In the second register figures a donkey-headed mummiform god kneeling on a reed mat grasping the royal scepters. The third register displays the *Ta-wer*-totem crowned with the double-feathered solar headdress standing on a pedestal.

Apparently loose hieroglyphs are found between the interstitial areas of the composition. An abundant use was made of liminal elements (*shetyt*-shrines, vultures and cobras) which are depicted around the main figures.⁶

Lower Section

This section is arranged in three longitudinal partitions bound by block-friezes (Fig. 16). Two longitudinal inscriptions run down the edges of the lid from the elbows to the footboard (Inscriptions 1–2).

The central partition is headed by a frieze of sacred cobras depicted in full frontal view. Elaborate friezes with geometrical and floral motifs divide the

5 The dynamism of this depiction is noteworthy, suggesting that the falcon is flying over the mummy and seen from above, which is a rare feature. See Sousa 2018b, 113, 128 (Fig. 35).

6 Interesting parallels with this composition can be found on the lid of the inner coffin kept in Budapest (Szepmuveszeti Muzeum, n. 51.2096). See Niwiński 1988, 114 n. 62. See also Liptay 2011, 43–57, Tav. 10–12. Another parallel can be found on the lid of the coffin kept in Genève (Musée d'Art et d'Histoire, n. 163). See Niwiński 1988, 140 n. 196. See also the lid of the outer coffin from Prague (Naprstkovo Muzeum, n.P.621), in Niwiński 1988, 167 n. 351; Verner 1982, 206–281. The similarities are noticeable, despite the fact that these are all examples of the special type of 'stola coffins' while on the lid of the coffin n. 8524 any kind of stola was painted. Our lid should represent the transition towards this new type. See chapter by Sousa, in this volume. See also the lid from the coffin from A.52 in Genève (Musée d'Art et d'Histoire, inv. N: 007363-012454). See Küffer, Siegman 2007.

registers. Each register is decorated with a symmetrical centripetal composition. In the first register the sacred scarab (black, moulded) holds up the solar disk (red, moulded) in its forelegs and displays the *shen*-ring between the hind legs. The solar disk is flanked by cobras. This composition is flanked by mummiform gods (moulded) kneeling on a mat (moulded) and grasping a feather. They wear a solar disk (red, moulded). The second register displays the *Ta-wer*-totem (moulded) crowned with the double-feathered headdress. The motif is flanked by sacred vultures (moulded) resting on reed mats, *shetyt*-shrines and piles of offerings.

The lateral partitions display three registers divided by short transversal bands of text (Inscriptions 4–11). Each scene depicts the deceased wearing a black garment knotted below her breasts. She wears a lotus bud on her head and holds an ointment vase with outflowing ointment over piled offerings. The shrine is crowned with a frieze supported by a double column. Inside, figures an enthroned deity with the *imi-wt*-totem at his feet. The upper part of each vignette is decorated with liminal elements (sacred cobra, *shetyt*-shrine, *heb*-bowl). In the first register the enthroned deity (moulded) is Osiris, grasping the royal scepters. In the second register a baboon-headed god grasps the royal scepters. In the third register is figured a falcon-headed god grasping the royal scepters.

Footboard

The footboard follows the same tripartite organization observed on the lower section. The edges are bounded by inscriptions (Inscriptions 1–2) and a block-frieze (Fig. 17). The central partition is inscribed with three columns of text (Inscription 3) bounded by block-friezes.

The lateral partitions are decorated with reversed vignettes featuring a mourning goddess squatting under a vaulted shrine. The goddess performs a mourning ritual before the *Ta-wer*-totem: she raises one arm and leans the other one on the floor holding the *shen*-ring. The *Ta-wer*-totem is crowned with the double-feathered solar headdress. The scene is completed with the *imi-wt*-totem and several offerings, while three horizontal strokes (*water*) allude to ritual libations.

In the second register a mummiform deity is kneeling on a reed mat, grasping the royal scepters. A coiled cobra wearing the *atef*-crown, outstretches its wings towards the deity, protecting the *udjat*-eye. Hieroglyphs are found between the interstitial areas of the composition forming full sentences: ‘*That she may give an invocation-offering*’ on the left side and ‘*That she may give offerings*’ on the right side.

Inscriptions

Two longitudinal inscriptions run down the edges from the elbows to the footboard (Inscriptions 1–2). The inscriptions are centripetally oriented (Fig. 9). The hieroglyphs are outlined in red on a yellow background. Some of the hieroglyphs are finely executed and multicoloured (blue, green and red), such as the newborn bubalis (Gardiner E9), the desert hare (Gardiner E34) or a variety of birds (Gardiner G25, G36, G38, G39).

Inscription 1

dd mdw in Gb, [–] r-[p]ᵀ ntrw, ʒḥ [p]w n s:ḏ hr pwy ms-n ʒst, iwꜥ pwy wr mnḥ wn-nfr, di.sn prt-ḥrw t, ḥnkt, ḥt-nb[t] nfr[t] ndm[t], ḥt-nbt. diw ḥt-nb[t], nn mwt [?] [–] [n]ḥhy

Words to be spoken by Geb, prince of the gods, this akh of his son Horus that was born from Isis, this great and beneficent heir of Unnefer, so that they may give an invocation offering consisting of bread and beer, everything good and sweet and everything given, and all things, without ever dying[?].

Inscription 2

dd mdw in Nwt [–] wrt, mst ntrw, ʒst Rꜥ, ḥnwt tʒw nbw, ʒḥ tw n s: s [?] hr pwy ms-n ʒst, iwꜥ pwy wr mnḥ n Wnn-nfr, di.sn prt-ḥrw t, ḥnkt, ḥt-nb[t] nfrt [–], ḥt-nb[t] [–]

Words to be spoken by Nut, the great one, who gave birth to the gods, the daughter of Re, the mistress of all the lands, this akh of her son Horus who was born by Isis, this great and beneficent heir of Unnefer, so that they may give an invocation offering consisting of bread and beer, everything good [–], everything [–].

The central partition of the footboard is inscribed with three columns of text (Inscription 3). The hieroglyphs are outlined in red and painted in blue, green and red (Fig. 10). The second column is slightly damaged at the centre. In the first column the space reserved for the name of the deceased was left blank. The great care taken in the rendering of each sign is noteworthy.

Inscription 3

(col. 1) *Wsir* [Space left blank for the name], *mꜣ-ḥrw. dd.s: ‘hʒy, mwt[.i] Nwt, psšn.t[?] dnḥwy hr.[i], di [w]nn[.i]* (col. 2) *mi iḥmw-sk, mi iḥmw-wrḏ, nn mwt[.i] m wḥm* (col. 3) *nn šnꜥ bʒ[.i] pw r ḥʒt[.i], wstn[.i] r tʒ-ḏsr, ḥwt-ʒst, smʒy[.i] šms[w]-ḥr, mʒʒ r[–]*’

(col. 1) *The Osiris* [Space left blank for the name], *justified*. She says: “Oh [my] mother Nut, stretch both your wings over [me] and let [me] be (col. 2) as the Imperishable Stars, as the Unweary Stars, so that I may not die again [---] (col. 3) so that this [my] Ba may not be repelled from [my] corpse and [I] may travel freely in the Sacred Land, [to] the Great Temple, and [I] may join the followers of Horus in order to see R[e (?)-]”.

Short transversal inscriptions divide the lower section in several registers (Inscriptions 4–11). All the inscriptions are centripetally oriented and present variations of the same text (Fig. 11). The first six texts are arranged in short bands (Inscriptions 4–9), referring to several manifestations of the ‘great god’, while the two bands on the footboard are longer and refer to Isis and Nephthys (Inscriptions 10–11). All the hieroglyphs are outlined in red and painted in blue, green and red.

Inscription 4

imꜣhy ḥr ntr ʕ, nb dwꜣt

The venerable one before the great god, lord of the Duat.

Inscription 5

imꜣhy ḥr ntr ʕ, nb ʔt

The venerable one before the great god, lord of the mound.

Inscription 6

(imꜣhy) ḥr ntr ʕ, nb ʔt

(The venerable one) before the great god, lord of the mound

Inscription 7

imꜣhy ḥr ntr ʕ, nb dwꜣt [s]ꜣꜣt

The venerable one before the great god, lord of the mysterious Duat.

Inscription 8

imꜣhy ḥr ntr ʕ, nb ʔt

The venerable one before the great god, lord of the mound.

Inscription 9

imꜣhy ḥr n̄tr ʿꜣ, ḥnty dwꜣt

The venerable one before the great god, foremost of the Duat.

Inscription 10

imꜣhy ḥr ꜣst, wrt, mwt n̄tr, sꜣt Rꜥ, ḥnwt tꜣw nbw

The venerable one before Isis, the great one, the divine mother, the daughter of Re, the mistress of all the lands.

Inscription 11

imꜣhy ḥr Nb-ḥwt

The venerable one before Nephthys, [---].

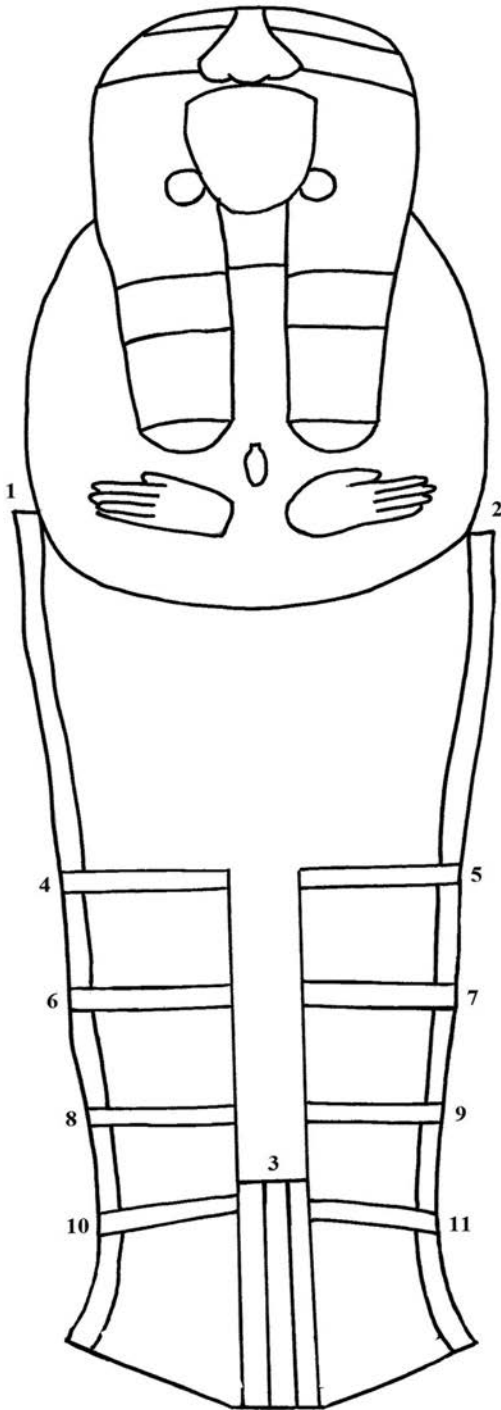

FIGURE 8
Outer lid (A.15). Inscriptions

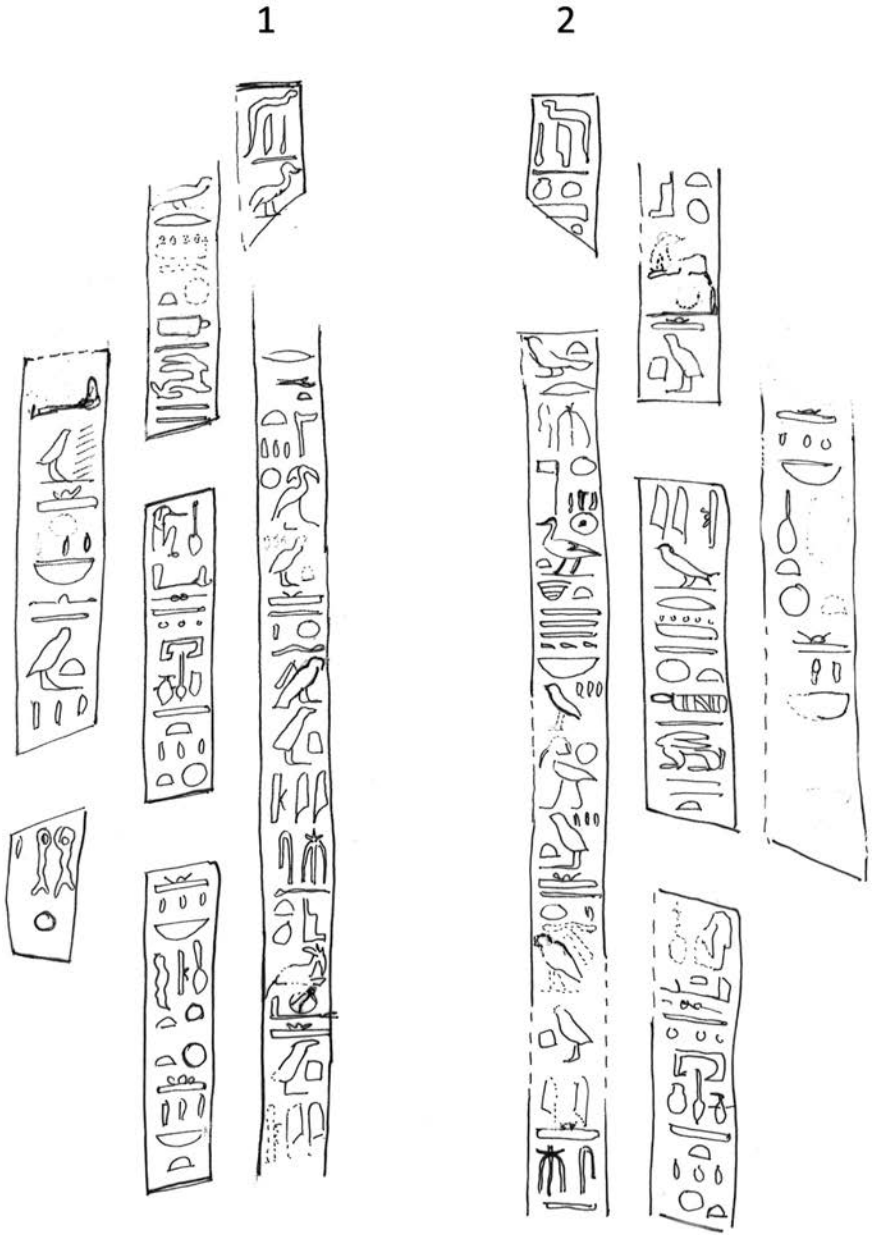

FIGURE 9 Outer lid (A.15). Inscriptions 1-2

3



FIGURE 10
Outer lid (A.15). Inscription 3

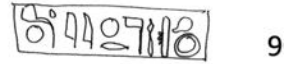

FIGURE 11 Outer lid (A.15). Inscriptions 4-11



FIGURE 12 Outer lid (A.15)



FIGURE 13 Outer lid (A.15). Headboard and upper section



FIGURE 14 Outer lid (A.15). Central panel

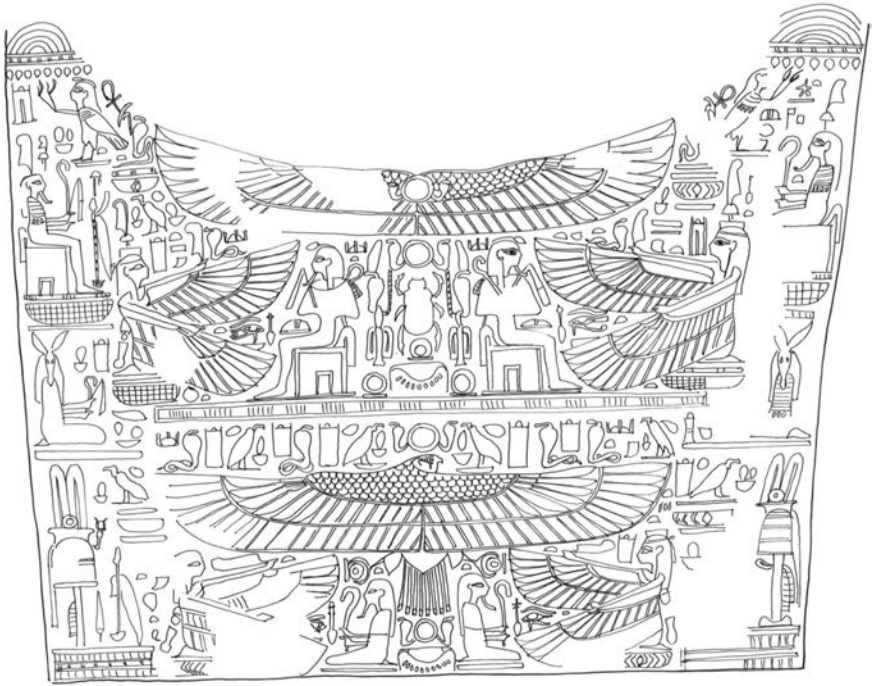

FIGURE 15 Outer lid (A.15). Central panel (drawing)



FIGURE 16 Outer lid (A.15). Lower section



FIGURE 17 Outer lid (A.15). Footboard

2. Outer Case

Museum inventory number: 8524

Length: 204 cm; Width (max): 67 cm; Depth: 43 cm

Wood, plaster, paint and varnish.

The exterior wall of the footboard remained undecorated.

The exterior decoration is preserved in good condition. Longitudinal cracks affect both sides along the whole length of the object. Four transversal cracks affect the headboard, revealing the joints between the wooden planks.

The interior decoration is well preserved, but a longitudinal crack runs along the centre of the floorboard. The painted decoration of the footboard is severely deteriorated.

Iconography (Exterior)

The upper edge is elegantly decorated with a frieze of alternating cobras (multicoloured) and feathers (green). Below, a band of hieroglyphic inscriptions (Inscriptions 1–2) runs from the headboard to the footboard. This inscription is bordered by block-friezes.

The vignettes are bounded by columns of hieroglyphic texts (Inscriptions 3–17) and thick monochromatic bands (black) running along the wall.

The lower edge is decorated with a block-frieze (multicoloured) and a monochromatic band (black).

Headboard

The headboard is composed of a tripartite panel, with the sides (*Vignettes 2–3*) centripetally oriented.¹

The *Vignette 1* (centre) shows a symmetrical composition with a large *tjet*-sign (red and blue) adorned with two flowers. It stands on the *nebu*-sign (Fig. 23). This motif is flanked by two standing snake-headed mummiform deities. They have curled beards and wear a feather on their heads. The *imiwt*-totem stands at their feet, and offerings. Above, figures the inscription “*Lord of the Place of Ma’at, foremost of the burial mound*” and several liminal elements (cobra, *nebu*-sign).

1 A similar composition is also found in the outer coffin of Ikhy, at the Vatican Museum. See Gasse 1996, 85, Tav. xv.

The side panels are decorated with a mummiform falcon-headed deity seated on a throne under a vaulted shrine supported by double columns. The deity grasps the royal scepters and wears the *atef*-crown. At his feet figures the *imi-wt*-totem. In the *Vignette 2* (left side) the area above is decorated with liminal elements (sacred cobra resting on a reed mat and a *heb*-bowl with the signs *was* and *ankh*) and loose hieroglyphs (Fig. 25). In the *Vignette 3* (right side), this same area is decorated with the *ba*-bird raising his arms before the enthroned god (Fig. 29).

Left Side

The upper section is decorated with two vignettes (*Vignettes 4–5*) forming a single scene depicting the god Thoth before two mummiform deities (Fig. 25).

The *Vignette 4* depicts the ibis-headed god identified as ‘*The lord of the burial mound, the foremost of the Duat*’ standing under a vaulted shrine (facing the footboard), raising the right arm above the offerings piled up on the table before him.

The *Vignette 5* shows a symmetrical centrifugal composition with the *sekhem*-scepter standing on the *shen*-ring. It is flanked by mummiform snake-headed deities with a libation stand at their feet. They both figure under a vaulted shrine. The title “*Lord of the Place of Ma’at*” is written on a single column of text.

The lower section presents three vignettes (*Vignettes 6–8*).

Although divided by four columns of text, the first two vignettes (*Vignettes 6–7*) form a single scene depicting the deceased performing a ritual before the solar barque (Fig. 26).²

In the *Vignette 6* the deceased stands under a vaulted shrine wearing the *usekh*-collar and a tight dress (black) knotted below her breasts. An unguent cone, a lotus bud and a headband with streamers adorn her head. She holds a vase with outflowing ointment over an offering table. At her feet stands the *imi-wt*-totem. The formula ‘*To give ointments for the Lady of the burial mound*’ is inscribed in three columns of hieroglyphs before the deceased.

The *Vignette 7* is divided in two registers by a thick black line resembling the *pet*-sign. On the upper part figures the solar barque with the sacred scarab depicted inside the *akhet*-sign. The sun disk is protected by a coiled snake. Above the stern the formula “*Following Re each day*” is written, while at the prow stands an altar provided with offerings. Two fishes are depicted below the

² A similar program is also detected on the outer case of Ikhy in the Vatican Museum (n. 25035: Gasse 1996, 85–87 and Tavv. XV–XVIII).

barque emerging from the water. In the lower register the head of the sacred falcon figures upside down rising from the *pet*-sign.³ A mummiform god is laying on the ground and rays of light shine upon him. Two mummiform gods (a jackal-headed god on the left and a falcon-headed on the right) flank the recumbent god. The remaining area is decorated with liminal elements (two sacred vultures with *ankh*-signs at their feet, *shetyt*-shrines, the *nebu*-sign) and loose hieroglyphic signs forming labels, such as 'Wadjet'.

The *Vignette 8* depicts the sacred cow going forth from the Theban Mountain (Fig. 27).⁴ The goddess stands on a high pedestal, facing the headboard. She has a maculated (black-spotted) hide and is adorned with the hathoric head-dress and the sistrum pending from her neck. A ritual vessel with lotus flowers figures at her feet. A winged cobra outstretches her wings towards the back of Hathor, with the *shen*-ring between them. The avian manifestation of the deceased rests on the pole of the West standing on the desert cliff, next to the tomb. The name 'Osiris' is inscribed on the pyramidal superstructure. Over the door of the tomb figures the sacred falcon resting on the pole of the West. On the upper area of the vignette, apparently loosely depicted hieroglyphs create labels, such as '*That she may give the offering*' (before the sacred cow), '*Neith*' (in front of the winged cobra), '*shetyt*-shrine' and '*The secret burial mound*' (around the *ba*-bird).

Right Side

The upper section is decorated with two vignettes (*Vignette 9–10*) forming a single scene depicting the god Thoth before two mummiform deities (Fig. 29).

In the *Vignette 9* the god Thoth is depicted in fully human shape standing under a vaulted shrine.⁵ He raises his left arm over the offerings piled up at his feet. Short labels refer to the '*Shrine of the fields of the Duat*'.

The *Vignette 10* shows a symmetrical centrifugal composition depicted under an elegant double-shrine supported by three columns. On both sides of the central column, a snake-headed mummiform god is seated on a throne resting on a *heb*-bowl. Both gods grasp the royal scepters and they both wear a feather on their heads. At their feet stands the *imi-wt*-totem. The remaining area is decorated with liminal elements (sacred cobras and '*shetyt*-shrines') and loose hieroglyphs forming labels, such as 'Wadjet', and 'Duat'.

3 On the significance of this motif see the chapter by Sousa in this volume.

4 An identical composition is also found in the outer coffin of Ikhy at the Vatican Museum (n. 25035; Gasse 1996, 87).

5 This motif is also found in the outer coffin of Ikhy at the Vatican Museum (n. 25035; Gasse 1996, 87. Cfr. *Vignette 9*).

The lower section presents four vignettes (*Vignettes 11–14*). As on the left side (cf. *Vignettes 6–7*), the *Vignettes 11–12* form a single scene depicting the deceased before the solar barque (Fig. 30).

In the *Vignette 11* the deceased stands under a vaulted ceiling holding a vase with outflowing ointment. An offering table piled up with food stands at her feet. The adjacent inscription presents the formula ‘*Give incense for the Lady of the sky*’.

The *Vignette 12* is divided in two registers by the *pet*-sign.⁶ On the upper register figures the solar barque with the sacred scarab depicted within the *akhet*-sign (cf. *Vignette 7*). The solar disk is protected by a coiled snake. The *shemsu*-sign and the pole of the West stand at the prow.

The lower register is entirely decorated with the coils of Apopis pierced with knives.

The *Vignette 13* depicts three mummiform gods standing on a coiled serpent (Fig. 31). The central ram-headed deity faces the headboard. He is flanked by a lion-headed (right) and a jackal-headed (left) deity, both centripetally oriented. Short labels refer to the ‘burial mound’ and ‘Duat’ above their heads.

The *Vignette 14* shows two enthroned mummiform gods (snake-headed) under a vaulted shrine. Both thrones rest on a single *heb*-bowl. The deities face the headboard and grasp the royal scepters. They have divine beards and wear a feather above the head (cf. *Vignettes 5* and *10*). The *imi-wt*-totem stands at their feet. Short labels refer to the ‘*shetyt*-shrine’.

Footboard

The footboard remained undecorated.

Iconography (Interior)

The thicknesses are flattened and painted yellow, with eight incisions for the mortars.

The multicoloured decoration is painted against a reddish background. The quality of the painting is excellent and the decorative program is rich (Fig. 32).⁷

6 An identical composition is also found in the outer coffin of Ikhy at the Vatican Museum (n. 25035; Gasse 1996, 87).

7 The decorative program reveals striking a resemblance to the interior decoration of the outer case of Ikhy at the Vatican Museum (n. 25035; Gasse 1996, 87–88 and Tavv. XVII–XVIII).

Headboard

The headboard is decorated with a beautiful depiction of the avian manifestation of the deceased depicted under a stary *pet*-sign (blue, with white stars). The female *ba*-bird outstretches her wings towards both sides of the case (Fig. 33). The head is elegantly attired with a long wig adorned with a *seshed*-headband, an unguent cone and a lotus bud. The face is beautifully depicted in profile (looking left). The feathers of the bird are multicoloured (white, green, black and yellow). Under her wings, figures a kneeling snake-headed mummiform deity grasping a flail. The formula '*Going forth to the Duat*' is written over each wing. All these features are transversally aligned with the registers depicted on the sides.

Another large *pet*-sign (blue, decorated with white stars) separates the decoration of the headboard from the decoration of the sides.

Sides

The sides are arranged in three registers (centrifugally oriented). Each register features an enthroned mummiform god depicted under a double vaulted shrine decorated with block-friezes. Each god wears mummy braces (red) and grasps a feather. Before him figures a cobra on a reed mat (above). The *imi-wt*-totem (white) stands at his feet beautifully decorated with blue dots (below). In the first and in the third registers the god depicted within the shrine is human-headed, wearing long wig and a curled beard. In the second register figures a baboon-headed deity.

Floorboard

The floorboard displays an imposing composition featuring three registers divided by large *pet*-signs (blue) decorated with yellow stars.

The first register features a large sun disk rising between the horns of a bull (Fig. 33). Inside the disk figure the *udjat*-eye and the *ba*-bird in the form of a stork with a lamp at his feet. This composition figures on a panther's head flanked by human-headed lions facing outwards. The bearded heads of the sphinxes are yellow, while the hair (blue) is adorned with a feather. Each sphinx holds a feather between the forelegs. A long coiled snake protects the sun disk. The whole composition rests on a reed mat.

In the second register an Osirian *djed*-pillar stands on the *nebu*-sign (Fig. 34). The pillar wears an elaborate *hememet*-crown showing two pairs of cobras pending from the horns. Two of them wear the *hedjet*-crown, while the other two wear the sun disk. The *hememet*-crown is decorated with six solar disks and four ostrich feathers (the central ones are depicted frontally). In the central vertebra of the pillar, two *udjat*-eyes flank the *nefer*-sign, beautifully suggesting

a human face. The fists (yellow) are crossed over the feathered torso grasping two *nekhakha*-flails. The lower section of the totem is inscribed with a long vertical column of hieroglyphic text (Inscription 18). On both sides of the pillar a symmetrical arrangement of hieroglyphs form the formulae ‘*Giving life, stability and strength*’ (at the sides of the crown) and ‘*Giving life and prosperous days forever*’ (flanking the base of the totem). On both sides of the totem a sacred vulture rests on a *heb*-bowl bearing the *nekhakha*-flail and the *ankh*-sign.

In the third register, the decoration has faded away (Fig. 35). A cryptic composition is encircled within the Ouroboros, comprising a donkey-headed mummiform god squatted on a reed mat grasping a feather. Loose hieroglyphs form the title ‘*He who dwells in the Duat, foremost of the shetyt-shrine*’.

Footboard

The footboard displays the uniform reddish colour of the background.

Inscriptions

The texts are written on a yellow background. Long horizontal inscriptions (Inscriptions 1–2) run along the upper edge, springing from a central motif, the *djed*-pillar, at the centre of the headboard.

The texts are outlined in red and coloured green, blue and red. It is worth to note the great care in the rendering of each sign and in the use of colours, especially in the human signs (Gardiner A8, A9, A40 and B1), in the barques (Gardiner P3 and its variations) in the birds (Gardiner G18, G20, G25, G29 and G44) and in other signs (Gardiner D6, K1, Q2 and the chick laying on a bier).

The passages of the Abdu-fish and the Inet-fish in Inscription 2 are variants of passages from Chapter 15 of the Book of the Dead 15.⁸

Inscription 1

imšhy hr Nb-hwt, ntr[t] ʿt, hnwt pr [nfr], Wsir, šh pw nty m dbʿt [s]štʿ[t]. dd.s: ʾ, ntrw ntr[w], nbw Imntyw sštʿw, hnty dwʿt ntr[t?], nʿ htp[w] m iʿwt, nʿ sdryw, ntry[w] nʿw wršw, nty[w] m ddw, nʿ bʿw nḥ[w], nty [m] int, psdt ʿt, nt[y] ʿš: hrw, dʿdʿt nt wsht (?mʿt[y].

The venerable one before Nephthys, the great goddess, the mistress of the House [of Embalming], and Osiris, this akh which is in the mysterious sarcophagus. She

8 Cf. Allen 1974, 13–17.

says: ‘Oh, gods and goddesses, lords of the secret Westerners, the foremost of the divine[?] Duat, those who rest in the mounds, those who sleep, the divine ones who spend the day—the one[s] in Busiris, the living baw who dwell in the valley, the Great Ennead, the one of many faces, the council of the Hall of the Double Ma’at’.

Inscription 2

imꜣhy hr ꜣst, wrt, mwt ntr, ḥnwt pr-nfr; Wsir ꜣḥ pw [nty] m dbꜣt. dd.s: pr.t r pt, dꜣ.t biꜣ, šnšn.tk [sic] (sis) m-m sbꜣw. Ir.tw n.t ḥknw m wiꜣ n Rꜣ, nis.tw [m] Mꜣndt. Mꜣꜣ(.t) ꜣbdw, [m](?) sp.f ḥpry, dg.f sr[t].n.f dg.t int m ḥpr.s, sšm.s sint m mw.s. Mꜣꜣ.t(.) itn wbn.f hr dww, sn-tꜣ ꜣḥw.f kꜣrst (?), kꜣrwt, rꜣ-nb

The venerable one before Isis, the great one, the divine mother, the mistress of the House of Embalming and Osiris, this akh [who is] in the sarcophagus. She says: ‘May you go forth to the sky, may you cross the firmament, may you associate with the stars. May one make praise for you in the barque of Re and may one summon you in the morning barque.’⁹ May you see the Abdu-fish, in his act of becoming, when he beholds what he prophesied, may you see the Inet-fish in its form, while she leads the canoe in its water. May you see the solar disk when it rises over the mountains, and when its sunshine kisses the earth of the burials(?) [and] the caverns, every day’.

The other texts (Inscriptions 3–17) are written in columns bounded by vertical lines (black). These texts are outlined in red and coloured green, blue and red. The left side displays 7 inscriptions (Inscriptions 3–9). Inscriptions 3, 5, 8 and 9 face the headboard, while Inscriptions 4, 6 and 7 face the footboard. Inscriptions 4 and 11 are variants from Chapter 161 of the Book of the Dead.¹⁰

Inscription 3

(col. 1) *dd mdw in Pth-skry, nb štyt, Ḥnpw nb* (col. 2) *tꜣ-dsr, Psdt-ꜣt nb ḥrt-ntr dꜣdꜣt ḥnty[t]*

(col. 1) *Words to be spoken by Ptah-Sokar, lord of the shetyt-shrine, [and] Anubis, lord of* (col. 2) *the Sacred Land, the Great Ennead, the god of the necropolis and the council which is in front of [---].*

9 A close parallel of this passage is found in Chassinat 1909, 50.

10 cf. Allen 1974, 156–157.

Inscription 4

(col. 1) *dd mdw in dḥwty, nb mdw ntr, sš mꜣt n Psdt* (col. 2) *-ꜣt: ‘nḥ Rꜣ, mt štyw, wḏꜣ nty m ꜣrs’*

(col. 1) *Words to be spoken by Thoth, lord of the divine words, scribe of Ma'at of the Great Ennead* (col. 2): *‘Re lives, the turtle dies, uninjured is the one who is in the grave’.*

Inscription 5

dd mdw in ntr ꜣ, nb tꜣ-dsr, ḥnty Mꜣnw

Words to be spoken by the great god, lord of the Sacred Land, foremost of the Manu Mountain.

Inscription 6

(col. 1) *ḥrp Ḳpp m sb n sdt m ḥrt-ḥrw nt rꜣ* (col. 2) *-nb. dḏ.k ḥr.k r imntt nfrt, dḏ bꜣw ḥtpw (?)*

(col. 1) *Providing Apopis with burnt-offerings as daily portion of each day.* (col. 2) *Turn your face towards the beautiful West so that the baw may give offerings (?).*

Inscription 7

(col. 1) *ihhy n.k Rꜣ-tm-ḥpꜣy*, (col. 2) *it ntrw, ir dt.f, kmꜣ ḥꜣw.f, sꜣꜣ-sw r* (col. 3) *ntrw nbw. dḏ.f-sw m pt, ntr bꜣ.f* (col. 4) *wbn ḥtp rꜣ-nb, mꜣꜣ-ḥrw.k ḥrt.k*

(col. 1) *Rejoicing to you, Re-Atum-Khepꜣy*, (col. 2) *father of the gods, who makes his [own] body, who creates his [own] flesh, who made himself greater than* (col. 3) *all the [other] gods, he places himself in the sky, whose ba is divine*, (col. 4) *who rises and sets every day, you are triumphant over your [snake-shaped] enemy.*

Inscription 8

(col. 1) *dd mdw in ḥft-ḥr-nb.s, ḥnwt smyt.s nbt ir[t]-ḥt* (col. 2) *mnḥt šḥrw, pḥr sbꜣw rmḥ m ḥtp(?)*

(col. 1) *Words to be spoken by Khefthernebes, the mistress of her necropolis, Lady of [cult] action*, (col. 2) *efficacious of plans, and who surrounds the Gates of Mankind with peace (?).*

Inscription 9

(col. 1) *ink imntt nfrt h3p[t] ntrw, didi[t] htpw m b3w r ntr-3, nb m3nw.*

(col. 1) *I am the beautiful West, the one who hides the gods who gives offerings*
(col. 2) *as baw [power] more than the great god, the Lord of the Manu Mountain.*

The right side displays 8 inscriptions (Inscriptions 10–17). Inscriptions 10, 11, 15, 16 and 17 face the headboard, while Inscriptions 12, 13 and 14 face the footboard.

Inscription 10

(col. 1) *dd mdw in Pth-skry, nb štyt, [In]pw nb t3-dsr, (col. 2) hnty [sh-ntr-] imy wt, hnty*

(col. 1) *Words to be spoken by Ptah-Sokar, lord of the shetyt-shrine, and [Anu]bis, lord of the Sacred Land, (col. 2) the foremost [of the sacred shrine ---], he who is in the embalming place, the foremost [---].*

Inscription 11

(col. 1) *dd mdw in dhwtj, nb mdw ntr, sš m3t n Psdt (col. 2) -3t: ʿnh Rʿ, mt štyw, wd3 nty [m] krs*

(col. 1) *Words to be spoken by Thoth, lord of the divine words, scribe of Maʿat of the Great Ennead (col. 2): ‘Re lives, the turtle dies, safe is the one [in] the grave’.*

Inscription 12

dd mdw in ntr 3, nb db3t, hnty štyt

Words to be spoken by the great god, lord of the sarcophagus, foremost of the mysterious/shetyt-shrine place.

Inscription 13

(col. 1) *mḏr m33 hr.k nfrj, di.k hr.k (col. 2) r h3st M3nw, dw3t b3w htptyw*

(col. 1) *Since your face has seen [the] beauty, turn your face (col. 2) towards the hill-country of Manu so that you may praise the bau [and] those who rest.*

Inscription 14

(col. 1) *Īhh n.k, w3.k m h[?]ʿwt (col. 2) ist.k m nhm, pt, t3, dw3t m (col. 3) ršrš, mḏr h3i stwt r.sn, (col. 4) n3 ntyw m db3t kf3 fnt*

(col. 1) *Praises to you, your barque is in joy, (col. 2) your crew) is in jubilation, the sky, the earth and the Duat (col. 3) are in rejoicing because of the descending of the [sun] rays towards them; those who (col. 4) are in the sarcophagus uncover the covers.*

Inscription 15

(col. 1) *dd mdw in n3 nbw nhḥ* (col. 2) *dt, Psdt ʿt, nt hrt-ntr, d3d3t nty m3ʿt[yt]*

(col. 1) *Words to be spoken by the lords of eternity (col. 2) and everlastingness, the Great Ennead of the necropolis, the council of the Place of the Double Ma'at.*

Inscription 16

(col. 1) *dd mdw in n3 nbw m3ʿty š3t[y]* (col. 2) *ḥnty šḥt-ḥrw ḥry-ib štyt*

(col. 1) *Words to be spoken by the lords of the mysterious Double Ma'at, (col. 2) the foremost of the Fields of Reeds, who dwell in the shetyt-shrine.*

Inscription 17

(col. 1) *dī.sn prt-ḥrw t ḥnkt, 3ḥw, 3pdw*, (col. 2) *ḥt-nb[t] nfr[t] wʿb[t], ḥt-nb[t] nfr[t] ndmt*

(col. 1) *That they may give an invocation offering consisting of bread and beer, oxen and fowl, (col. 2) everything good and pure, everything good and sweet.*

Inscription 18 is found inside the case, written against a yellow background and bordered by two vertical lines (black) in the lower part of the *djed*-pillar. The texts are outlined in red and coloured green, blue and red.

Inscription 18

ḥtp di nsw wsir, ḥnty ḥmntt, nb nhḥ, ḥry-tp igrt, pḥ-skr nb štyt

An offering that the king gives to Osiris, foremost of the Westerners, lord of eternity, who has authority over Igeret [and] to Ptah-Sokar/is, lord of the shetyt-shrine.

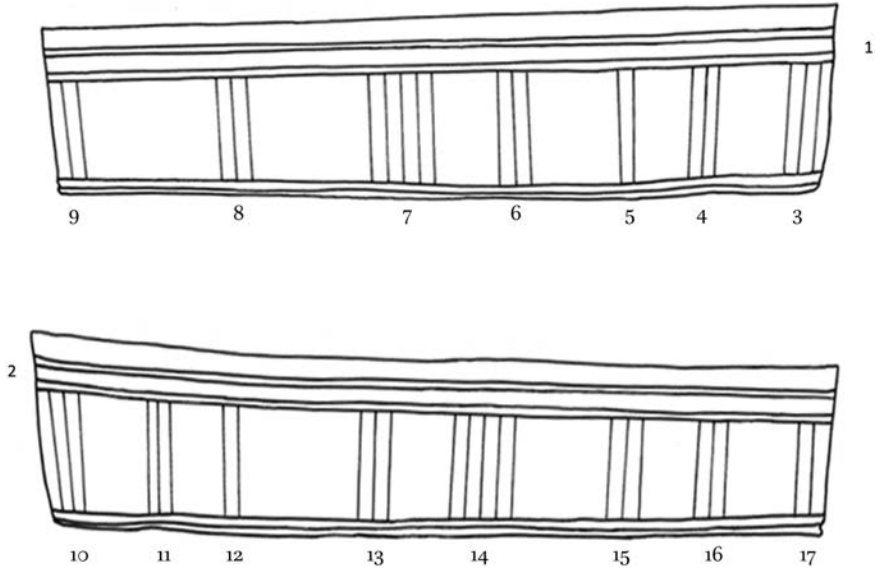

FIGURE 18 Outer case (A.15). Inscriptions

1



2

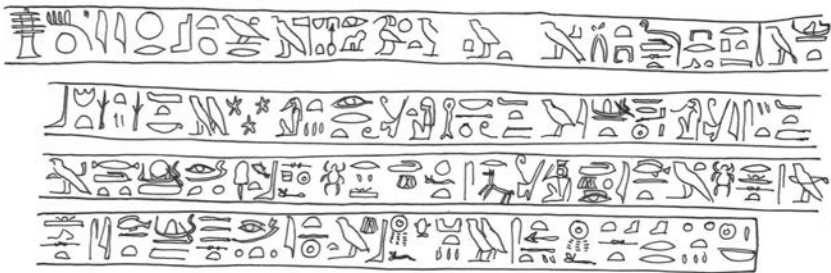

FIGURE 19 Outer case (A.15). Inscriptions 1-2

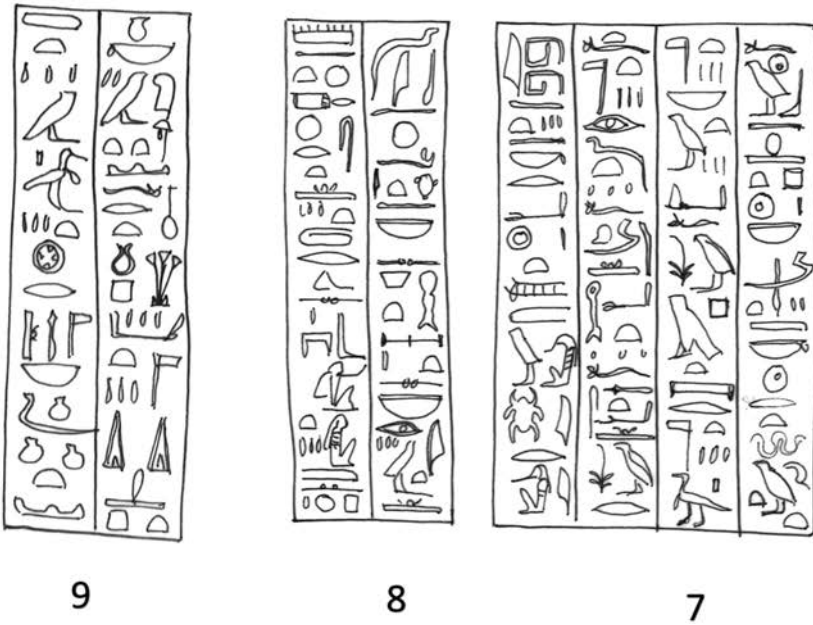
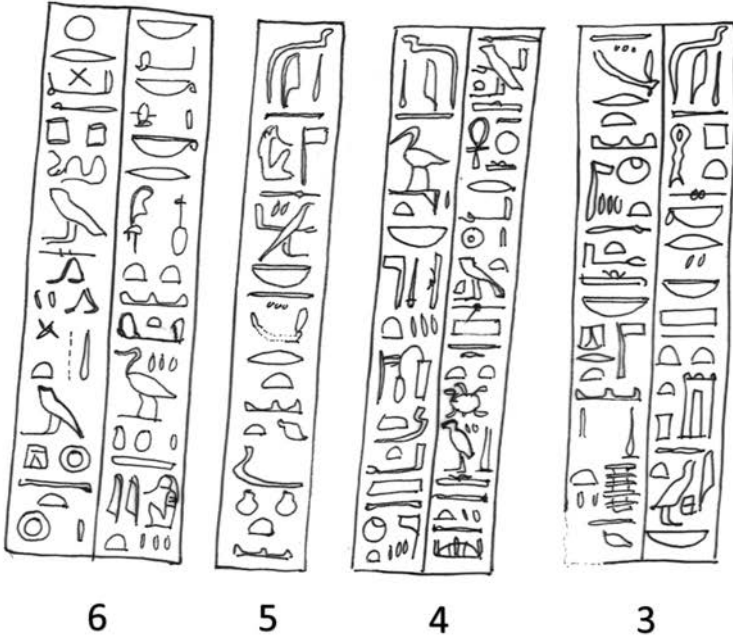
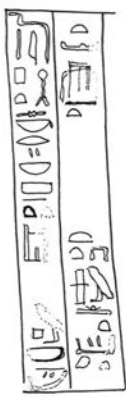

FIGURE 20 Outer case (A.15). Inscriptions 3–9



10



11



12



13



14



15



16



17

FIGURE 21 Outer case (A.15). Inscriptions 10–17

18



FIGURE 22
Outer case (A.15). Inscription 18



FIGURE 23 Outer case (A.15). Headboard

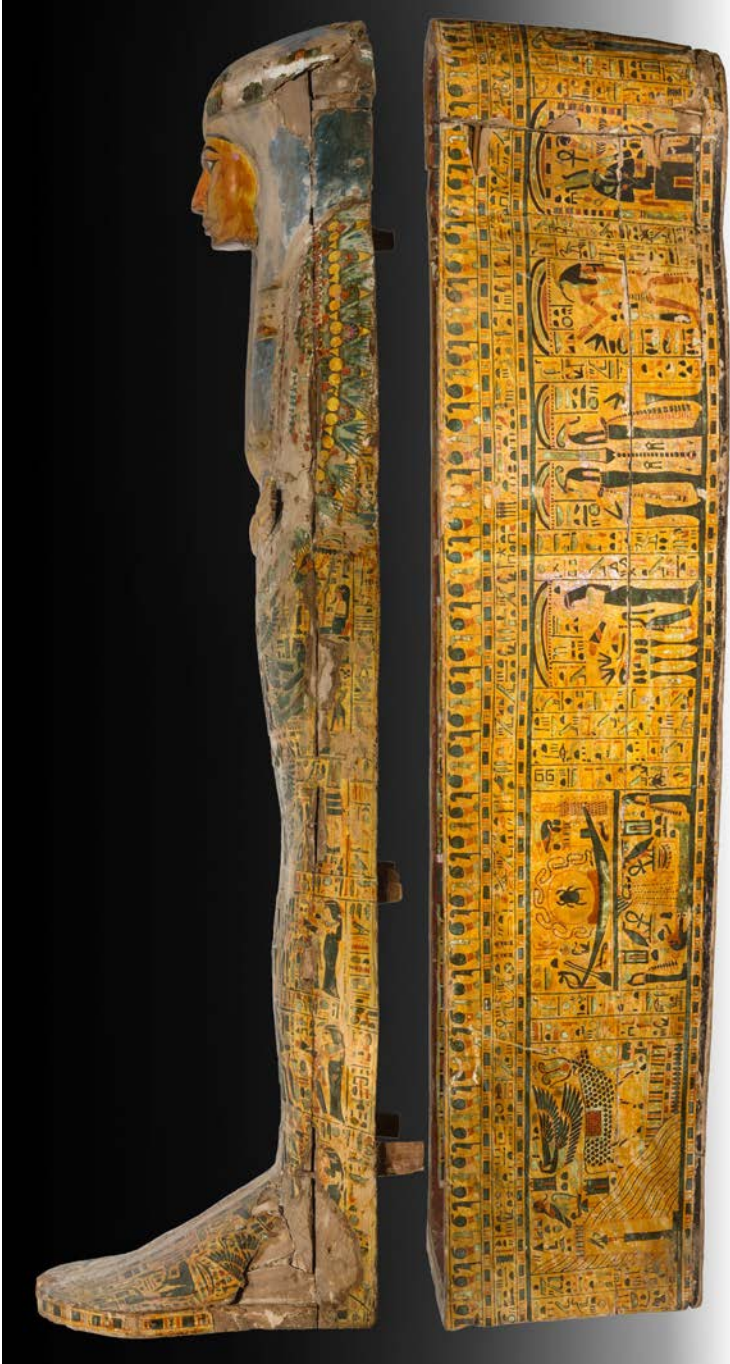

FIGURE 24 Outer case (A.15). Left side



FIGURE 25 Outer case (A.15). Left side, upper section



FIGURE 26 Outer case (A.15). Left side, middle section



FIGURE 27 Outer case (A.15). Left side, lower section



FIGURE 28 Outer case (A.15). Right side



FIGURE 29 Outer case (A.15). Right side, upper section



FIGURE 30 Outer case (A.15). Right side, middle section



FIGURE 31 Outer case (A.15). Right side, lower section



FIGURE 32 Outer case (A.15). Interior decoration



FIGURE 33 Outer case (A.15). Interior decoration, headboard (above), detail of the floorboard (below)



FIGURE 34 Outer case (A.15). Interior decoration (floorboard)



FIGURE 35 Outer case (A.15). Interior decoration (detail of the floorboard)

3. Inner Lid

Museum inventory number: 8528

Length: 188 cm; Width (max): 51 cm

Wood, plaster, paint and varnish.

Decorated with multicoloured paintwork and profuse use of moulded plaster.

The reverse side of the object is undecorated, as well as the underside of the footboard.

The object is preserved in good condition. Some cracks affect the headboard, and the footboard. The hands, previously attached to the lid, had been ripped off.

Iconography

Headboard

A large multicoloured headband decorated with lotus petals and geometrical motifs adorns the wig (Figs. 40–41). A bunch of three lotus flowers hangs from the crown of the head. The austere face is well carved. The skin is yellow and the contours of the eyes and eyebrows are outlined in black. Unlike the outer lid, the pupils (black) are painted against a yellow background. A red line is traced to suggest the contours of the lips, nostrils and eye-lids. On the neck, two red horizontal lines depict creases on the throat.¹

The round earrings are moulded and decorated with multicoloured rosettes.

The wig is decorated with a checkered pattern and, because of that, the lappets are not decorated with binding bands.²

Upper Section

The breasts (moulded in plaster) figure below the lappets of the wig featuring small rosettes. The elbows are decorated with large multicoloured lotus flowers. The forearms are hidden under the floral collar (Figs. 40–41).

The area comprised between the lappets of the wig presents a short collar composed of nine transversal bands decorated with pearl-beaded motifs.³

1 See, for example, the objects from A.68: mummy-cover (British Museum, EA 24797) and lid (Kunsthistorisches Museum, Äs 6267a).

2 See Sousa 2018b, 50–51.

3 See Sousa 2018b, 59.

The floral collar is large, displaying twelve bands, but the variety of floral patterns is reduced, showing checkered motifs (2nd, 4th, 6th, 8th, 10th, 12th registers), perseas-tree buds (3rd, 7th, 11th bands), lotus petals (5th, 9th bands) and lotus flowers intertwined with acacia flowers (1st band).

On the chest, between the breasts and the hands, lies a pectoral depicting a winged scarab (moulded) holding up a solar disk in its forelegs and grasping the *shen-ring* with the hind legs. The sun-disk is flanked by cobras and sacred vultures.

Central Panel

The central panel is composed of nine registers, displaying large winged deities (2nd, 4th, 6th, 8th registers) or symmetrical compositions (1st, 3rd, 5th, 7th and 9th registers). This unusually long tableau required all the available space on the lid and for this reason the pictorial scheme typically used in the lower section was omitted (Figs. 44/301). Some of the motifs of the composition are moulded in plaster to suggest relief, such as the scarabs, the bodies of the enthroned gods, the *hwt*-thrones, and the dresses of the winged goddesses. The tableau is bounded by longitudinal bands of text (Inscriptions 1–2) that run down the edges.

The nuclear block of the **first register** shows a sacred scarab holding up a solar disk in its forelegs while the *shen-ring* figures between the hind legs (Fig. 42). The scarab is flanked by large *tjet*-signs hanging from the *iaret*-cobras. Centrifugal blocks display the enthroned mummiform Osiris. He has a curled beard, wears the *hedjet*-crown and grasps the royal scepters. The centripetal blocks display a winged goddess squatted on a high platform outstretching her wings towards Osiris. The head of the goddess is adorned with long red streamers and a sun-disk encircled by a cobra wearing the *hedjet*-crown. The avian manifestation of the deceased rests under her wings, also wearing long red streamers. The centripetal block includes a standing mummiform god, with curled beard, and wearing the *hedjet*-crown. He figures under a vaulted shrine with an offering table at his feet (only on the right side). Above, the following labels can be found: ‘*Osiris*’ (before the head of the enthroned gods), ‘*The great god of the Duat*’ (before the head of the winged goddesses) and ‘*The great god, lord of the Duat*’ (before the standing mummiform deities).

In the **second register** a large kneeling goddess outstretches her wings towards both sides of the lid. She is green-skinned and wears a tight dress (blue). Her head is decorated with the modium and a headband. A geometric frieze is arranged above the wings of the goddess.

The **third register** recalls the composition of the first, with slight differences: the squatting goddesses are identified as ‘*Neith*’ and the standing mummiform gods wear a long wig adorned with an unguent cone and a lotus bud.

The **fourth register** repeats the composition of the second one (Fig. 43).

The **fifth register** introduces variations to the scheme described above. The centrifugal blocks depict a kneeling mummiform Osiris, and the centripetal blocks now include a winged cobra crowned with the sun-disk. The *udjat*-eye figures under its wings. The standing mummiform god is human-headed on the left, and snake-headed on the right. Loose hieroglyphs are found between the interstitial areas of the composition.

The **sixth register** displays a large winged goddess with her arms outstretched towards both sides of the lid.

In the **seventh register** the centrifugal block was excluded and the nuclear block is flanked by centripetal blocks featuring the avian manifestation of the deceased resting on a *heb*-bowl with a feather at his feet. The *ba*-bird has a curled beard and wears a sun-disk on his head encircled within the body of a centrifugal cobra. At the back of the bird figures the winged *udjat*-eye with a pending cobra wearing the *hedjet*-crown and the *menat*-counterpoise. The standing mummiform god is snake-headed on the left, and human-headed on the right. They both have divine beard and wear a feather above the head. Loose hieroglyphs are found between the interstitial areas of the composition, forming complete sentences: '*Praising the great god who dwells in the Duat*' on the right side and '*The great god who dwells in Thebes*' on the left.

The **eighth register** depicts a large winged goddess and in the **ninth register** the centrifugal blocks show a kneeling Osiris wearing the *hedjet*-crown adorned with long red streamers. The centripetal blocks depict the winged *udjat*-eye with a pending solar cobra wearing the *ankh*-sign on its neck. Additional blocks include standing mummiform gods (baboon-headed on the right side and snake-headed on the left side). Loose hieroglyphs are found between the interstitial areas of the composition.

Footboard

This area displays a tripartite organization (Fig. 45). The central partition is inscribed with four columns of text (Inscription 3) bounded by block-friezes. The lateral partitions are decorated with reversed vignettes depicting a mourning scene under a vaulted shrine. The mourning goddess is squatted on the *nebu*-sign before the enthroned Osiris. She is green-skinned and wears a tight dress decorated with a beaded-motif (red). She is crowned with the modium. The god wears the *hedjet*-crown and grasps the royal scepters. The throne rests on a *heb*-bowl. The following labels can be found: '*Neith, the powerful*' (right side) and '*Neith the great goddess*' (left side).

The edges are decorated with a geometrical frieze.

Inscriptions

The texts are written on a yellow background. Two longitudinal inscriptions run down the edges from the elbows to the footboard (Inscriptions 1–2). The inscriptions are centripetally oriented. The hieroglyphs are outlined in red and painted in blue, green and red. Calligraphy tends to be cursive, following the style of the whole decoration of the object.

Inscription 1

Īnk Nwt, wrt, ms n ntrw, sst Rꜥ, hnwt tꜣw nbw, nbt nrw, hnty Īmntt m ꜣbdw, di.f [sic] ht-nb[t] nfr[t] wꜣbt, ht-nb[t] nfr[t] ndmt, ht-nbt pt, ht-nbt tꜣ, ht-nbt dwꜣt, ht-nbt Īmntt nfr[t]

I am Nut, the great one, who begot the gods, the daughter of Re, the mistress of all the lands, the lady of dread, the foremost of the West in Abydos, so that he [sic] may give everything good and pure, everything good and sweet, everything from the sky, everything from the earth, everything from the Duat, everything from the beautiful West.

Inscription 2

Īnk Gb, r-pt ntrw, ꜣh n sꜣ.[f] pwy hr ms n ꜣst, iwꜣ mnḥ n wn-nfr ḥꜣꜣ, di.sn ht-nb[t] nfr[t] wꜣb[t], ht-nbt pt, ht-nbt tꜣ dwꜣt, ht-nbt nfrt [nt] Īmntt nfr[t], ht-nb[t] nfr[t] dwꜣt [s]štꜣ[t]

I am Geb, prince of the gods, akh of this [his] son Horus whom Isis had born/generated, beneficent heir of Unnefer the ruler, that they may give everything good and pure, everything from the sky, the earth and from the Duat, everything good from the beautiful West, everything good from the mysterious Duat.

The central partition of the footboard is inscribed with four columns of text (Inscription 3). The hieroglyphs are outlined in red and painted in blue, green and red. In the first column the space reserved for the name of the deceased was left blank.

Inscription 3

(col. 1) *Wsir, nbt-pr, šmꜣt n Īmn-Rꜥ, nsw-ntr* [Space left blank for the name]. *dd.s: ‘hꜣy,* (col. 2) *Nwt, psš.t dnḥwy.t hr.i, di[t] wnn.[i] mi* (col. 3) *ihmw-sk, ihmw-wrd,* (col. 4) *im[sic!] [nn] mwt.[i] m whm [m] pr ntr-ꜣ nty [m] Īmnt nfr[t]’*

(col. 1) *The Osiris, the mistress of the house, the chantress of Amun-Re king of the gods* [Space left blank for the name]. *She says: [oh]* (col. 2) *Nut, spread out your*

wings over me and let (me) be as (col. 3) the Imperishable stars, and the Unweary stars, (col. 4) so that I may not die again in the house of the great god who is [in] the beautiful West'.

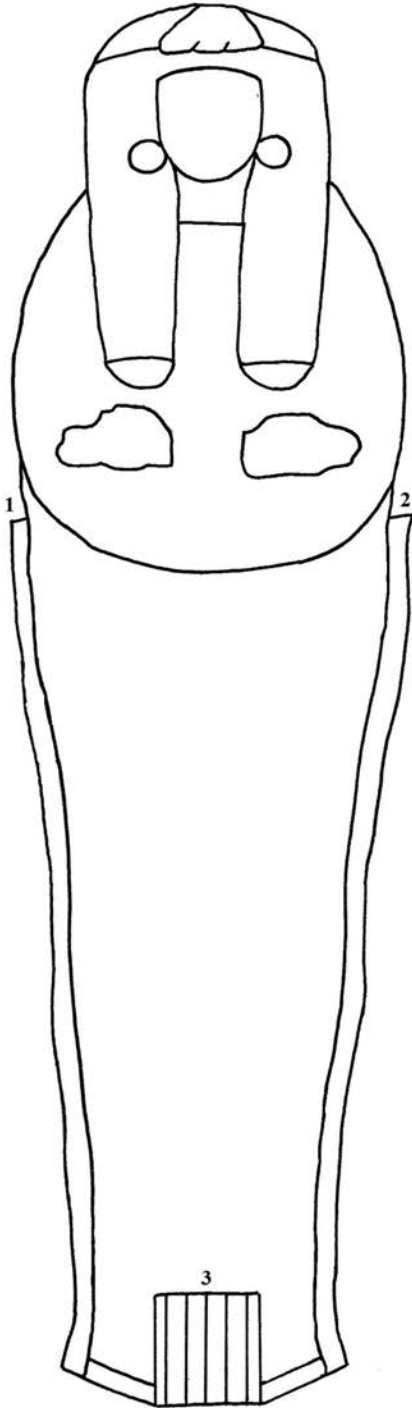

FIGURE 36
Inner lid (A.15). Inscriptions

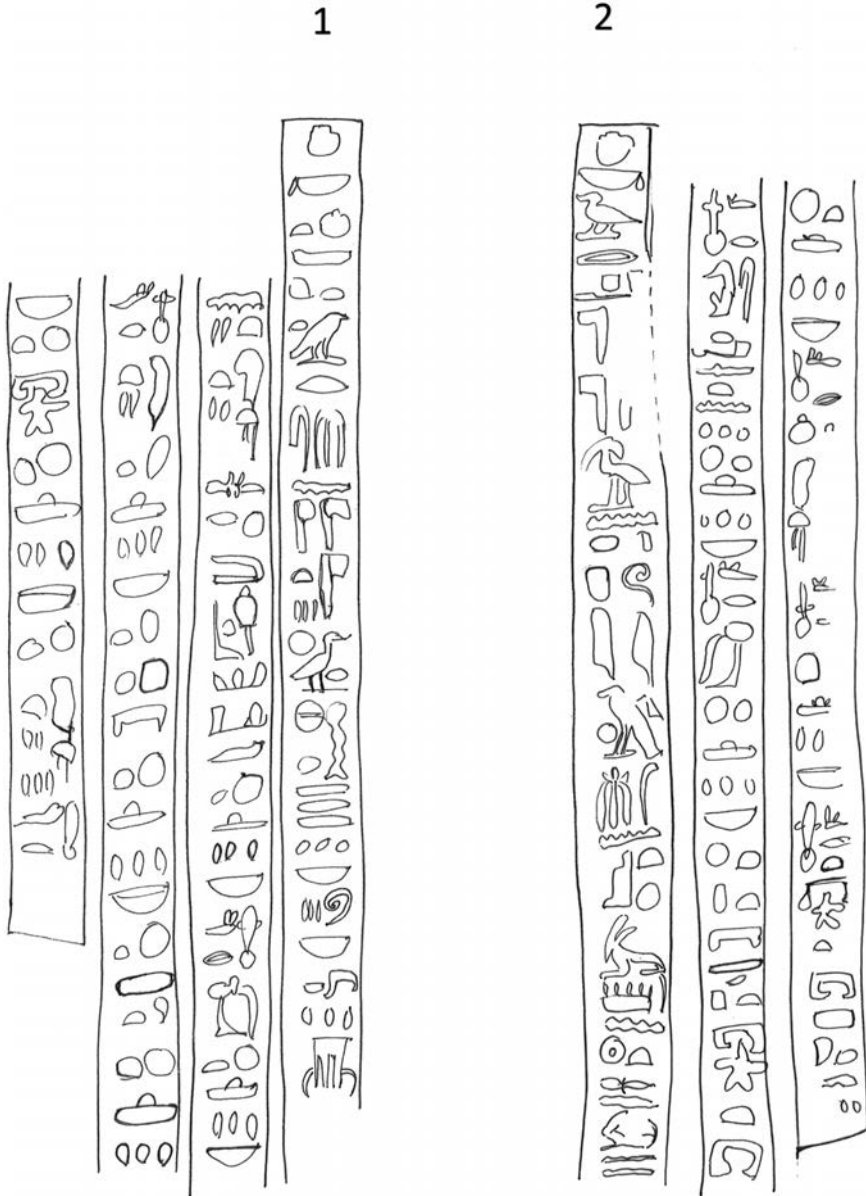

FIGURE 37 Inner lid (A.15). Inscriptions 1-2



FIGURE 39
Inner lid (A.15)



FIGURE 40 Inner lid (A.15). Headboard and upper section

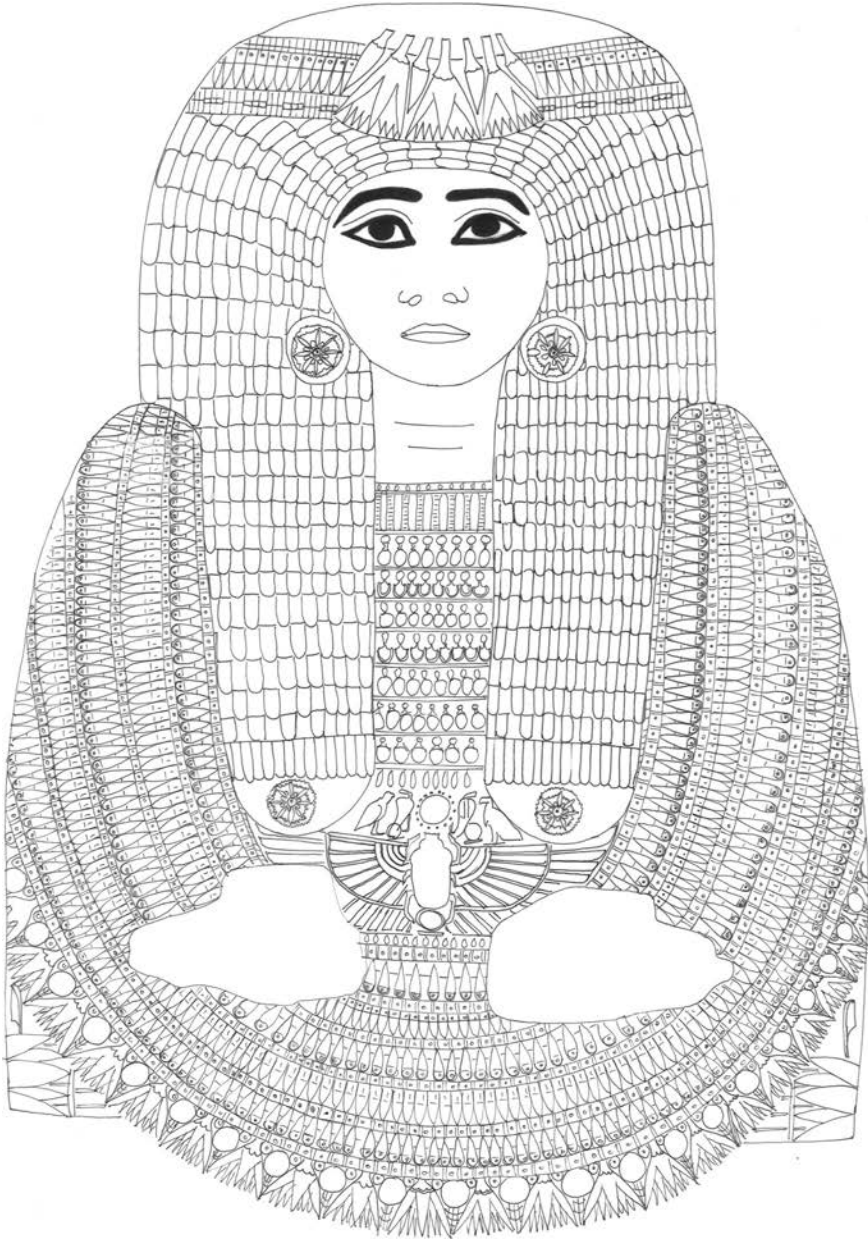

FIGURE 41 Inner lid (A.15). Headboard and upper section (drawing)



FIGURE 42 Inner lid (A.15). Central panel (detail)



FIGURE 43 Inner lid (A.15). Central panel (detail)



FIGURE 44
Inner lid (A.15).
Central panel
(drawing)



FIGURE 45 Inner lid (A.15). Footboard

4. Inner Case

Museum inventory number: 8528

Length: 188 cm; Width (max): 51 cm; Depth: 30,5 cm

Wood, plaster, paint and varnish.

The exterior wall of the footboard remained undecorated.

The exterior decoration is preserved in good condition. Some cracks affect the headboard revealing the joints between the wooden planks. A little crack is detected on the footboard. The interior decoration is well preserved but some cracks affect the headboard.

The object was restored in the workshops of the Florence Museum in 1957–1958.¹

Iconography (Exterior)

The upper edge is decorated with a frieze of alternating cobras (multicoloured) and feathers (green). Below, a band of hieroglyphic inscriptions (Inscriptions 1–2) runs from the headboard to the footboard. This inscription is bordered by block-friezes (Fig. 50).

The scenes painted on the sides of the case are depicted seamless, with only two columns of text (Inscriptions 3–4) dividing the sides from the headboard.

The lower edge is decorated with a block-frieze and a tick monochromatic band (black).

Headboard

The headboard reveals an exceptional layout displaying a single panel (*Vignette 1*) showing a solar barque at the centre of a symmetrical composition (Fig. 49). The barque navigates the sky (it rests on the *pet*-sign) and carries the winged scarab rising from the *neb*-sign and holding up a solar disk in its forelegs. The sun disk is flanked by cobras and *udjat*-eyes. Two fishes emerge from the waters of the sky and flank the solar barque. The *pet*-sign rests on a long coiled snake (red and blue). The centripetal blocks depict standing mummiform gods, with curled beard, wearing the *hedjet*-crown. Hieroglyphic labels identify the figures as ‘*The great god in the Duat*’.

¹ Bosticco 1958, 14–15.

Left Side

The left side is decorated with a single vignette (*Vignette 2*) featuring six scenes without any formal division between them.

The **first scene** figures on the side panel of the headboard (Fig. 51). The deceased is depicted as a man wearing the royal kilt (multicoloured) and a bull's tail pending from his waist. He has a squared beard and wears a short wig (blue) adorned with streamers (red). The deceased offers an ointment vessel to two sacred falcons resting on a *heb*-bowl under a vaulted shrine. Both avian gods wear the *atef*-crown and the *menat*-counterpoise. Hieroglyphic labels identify these figures as '*The great god*' (male figure) and '*The lord of dread, who is in the Duat*' (falcons).

The **second scene** covers the upper section consisting in a symmetric composition featuring the solar barque at the centre (Fig. 51). The scene recalls the composition featured on the head-board. The barque rests on the *pet*-sign and carries the winged scarab flanked by *djed*-pillars. Two fishes emerge from the *pet*-sign, which rests on a coiled cobra (red and blue). Centripetal blocks flank the solar barque. On the right side, stand three mummiform deities, all of them with curled beards: the first and the third god wear long wigs (with unguent cone and lotus bud) while the second deity wears the *hedjet*-crown. On the left side another triad is featured. The first and the third gods wear the *hedjet*-crown (first) and the *desheret*-crown (third), while the second is a goddess, wearing the hathoric headdress. All of them raise their left arm towards the barque. Short labels are found between the interstitial areas of the composition.

The lower section includes four different scenes (Fig. 52).

The **third scene** is a symmetrical composition with a column of hieroglyphs at the centre: '*(The One) who is in the perfect Duat*'. Flanking this column, centrifugal blocks display a standing mummiform god with long wig. He is facing an enthroned hare-headed mummiform god grasping the royal scepters. The throne rests on a *heb*-bowl and a large offering table piled up with offerings stands at his feet.

The **fourth scene** is a symmetrical composition with two *sekhem*-scepters at the centre. This motif is flanked by centrifugal blocks featuring an enthroned mummiform god wearing the *hedjet*-crown and grasping the royal scepters. The *imi-wt*-totem stands at his feet. The centripetal block includes a kingly figure, with a bull's tail pending from his waist. He has curled beard and wears short wig adorned with an unguent cone and a lotus bud. He raises his arm towards the enthroned god. A large offering table stands between them. The following labels can be found: '*god*' and '*The great god who is in the Duat*'.

The **fifth scene** depicts the avian manifestation of the deceased drinking water poured by the goddess of the sycamore. The *ba*-bird is depicted with bearded head wearing an unguent cone with a lotus bud and a *menat*-counterpoise at his back. He raises his hands to drink. The winged *udjat*-eye figures above the *ba*-bird while a small offering table stands at his feet. The goddess is depicted with green skin and her tight dress is decorated with a beaded-motif (red). The monogram of Nephthys figures on her head. Behind the goddess figures the sycamore fig tree, flanked by two *shen*-rings. Short labels write the word '*libation*' between the goddess and the *ba*.

The **sixth scene** features the sacred cow going forth from the Theban Mountain. The deceased is depicted in kingly attire, wearing the *hedjet*-crown, tight kilt and the ritual bull's tail pending from his waist. He has divine beard and raises his right arm pouring libations above a pile of offerings. The sacred cow stands on a pedestal facing the headboard. The goddess has a maculated (black-spotted) hide and she is adorned with the hathoric headdress, the *menat*-counterpoise and a beaded drape on her back. At her feet figures a ritual vessel with lotus flowers. Two *nefer*-signs, the *udjat*-eye and the *heb*-bowl figure above her. A winged cobra outstretches her wings towards the goddess embracing the *shen*-ring. The Theban Mountain is depicted behind the goddess and vestiges of the tomb are detected on the left edge (damaged). Short labels refer to the '*great god*' (before the deceased), and to '*Neith, Lady of the Two Lands*' (before the goddess).

Right Side

The right side is decorated with a single vignette (*Vignette 3*) displaying five scenes without any division between them (Fig. 53).

The **first scene** figures on the side panel of the headboard (Fig. 54). The deceased is depicted in kingly attire, wearing a royal kilt and the bull's tail suspended from his waist. A short wig adorns the head, with an unguent cone and a lotus bud. He raises his left arm towards the sacred falcon resting on a *heb*-bowl under a vaulted shrine. The avian god is crowned with a solar disk flanked by pending cobras. At his back the green-skinned goddess '*Nephthys*' is squatted on a *heb*-bowl outstretching her wings towards the avian god, and embracing the *udjat*-eye. Short labels are found between the interstitial areas of the composition, such as '*The god who is in the Duat*' (deceased), '*The sister of the great god*' (winged goddess).

The **second scene** (on the upper section) features a cosmological depiction with the god Shu (centre) holding up the body of the heavenly goddess Nut (Fig. 54). Shu ('*The great god who is in the Duat, Lord of the gods*') is depicted

motionless with his legs standing side by side. He has a curled beard and wears a short kilt and a cap with his monogram and a scarf. The earthly god Geb is laying on the ground (green-skinned, with *usekh*-collar and divine beard), while the bending body of the goddess Nut is beautifully studded with blue stars. Shu is flanked by *ba*-birds raising their arms in adoration. Below, the god Geb is flanked by a vulture (at his feet) and a cobra crowned with the sun disk (facing his head). This scene is completed with centripetal blocks depicting sacred falcons resting on the pole of the West. These poles rise from the hands (left) and feet (right) of Nut. A standing mummiform god wearing a *hedjet*-crown flanks the composition, with a large offering table piled up with offerings at his feet.

The lower section is decorated with four scenes (Fig. 55).

The **third scene** depicts the deceased before an offering table. Exceptionally, the deceased wears a festive white garment and a long wig adorned with an unguent cone and streamers. He wears a *usekh*-collar and a large heart amulet (red). He raises his left arm before the offering table, piled up with loaves and vessels. Four ducks hang down from the table.

The **fourth scene** displays a symmetrical composition with two *Ta-wer*-totems at the centre (cf. fourth scene on the left side). Between the totems a short label refers to 'who is in' (Abydos, as the totems suggest). They are flanked by centrifugal blocks featuring enthroned mummiform gods wearing the *hedjet*-crown and grasping the royal scepters. The *imi-wt*-totem stands at their feet. All these motifs rest on a single *heb*-bowl. The centripetal block depicts a winged goddess squatted on a pedestal outstretching her wings towards Osiris and embracing the *ba*-bird. Short labels refer to 'Neith, the divine sister' (winged goddess) and 'Osiris, the great god' (enthroned god).

The **fifth scene** depicts a standing mummiform god with a large offering table at his feet. The god faces the footboard. He has divine beard and his long wig is adorned with an unguent cone and a lotus bud.

The **sixth scene** shows ten mummiform kneeling gods facing the headboard. Each god is depicted under a vaulted shrine. They all grasp royal scepters and wear the *usekh*-collar. Some of these gods are human-headed (1st, 3rd, and the 10th). Those gods have curled beard and wear unguent cone with lotus buds. Others are snake-headed (the 2nd, the 4th and the 8th) and wear a feather and the divine beard. The 5th and the 6th gods are hippopotamus-headed, while the 9th is crocodile-headed (his body is damaged).

Footboard

The footboard remained undecorated (Fig. 49).

Iconography (Interior)

The thicknesses are stepped and painted yellow (Fig. 56). The mortars (four at each side) are positioned in the transition from the lower to the higher edge.

The background of the interior decoration is reddish studded with yellow stars. The quality of the pictorial work is outstanding.

Headboard

The headboard is decorated with a large falcon shown in full frontal view under a *pet*-sign (black, decorated with yellow stars). The avian god outstretches its wings towards both sides of the case (Fig. 57). The depiction is very naturalistic and depicts the falcon as flying over the mummy. The body and wings of the animal are multicoloured (green, black and white), while the legs painted in yellow. Under each wing, a sacred vulture is depicted in transversal position, facing the floorboard. The goddess wears the *atef*-crown and rests on a *heb*-bowl, carrying the flail on its back. A large lotus flower figures over its head.

Another large *pet*-sign (black, decorated with yellow stars) separates the decoration of the headboard from the decoration of the sides.

Sides

The sides are arranged in four registers (centrifugally oriented), each one of them displaying three standing mummiform gods (Fig. 56). Each god wears a funerary collar (yellow), mummy braces (red) and long belts (yellow/white). These gods stand on large *pet*-signs (black) sprinkled with stars (yellow).

In the first register, the outer god is human-headed (with curled beard), the second is falcon-headed and the third one is baboon-headed.

In the second register, the first and the third deities are snake-headed (with curled beard). The second god is vulture-headed.

In the third register, the outer god is lion-headed (?), the central one is goat-headed (?) and the third one is shrew-headed.

In the fourth register, the outer god is jackal-headed. He is followed by a bull-headed god and a deity resembling the Sethian animal (?).

Floorboard

The floorboard displays an imposing composition arranged in four registers divided by large *pet*-signs (black) sprinkled with yellow stars (Figs. 56/58).

The first register depicts the solar barque on a starry *pet*-sign. The scene is delimited by the heavenly dome depicted as an inverted U-shaped *pet*-sign (cf. outer case from A.60-Fig. 163). At the centre, the sun disk rises from the horns of a bull's head rendered frontally. The solar disk is flanked on both sides by

the avian manifestations of the deceased facing outwards. The *ba*-birds are adorned with striped wigs and curled beards.

The second register features a majestic depiction of the goddess Neith standing on the *nebu*-sign (Fig. 58). The goddess wears an elegant striped wig (black) adorned with a knotted *sheshed*-headband (white). The *iaret*-cobra caps the head of the goddess, rising on her forehead. Neith is crowned with a modium surmounted by her own monogram. A multicoloured *usekh*-collar adorns her chest. Her tight dress is decorated with a rather unusual and sophisticated pattern combining a flower (white) with a geometrical motif (yellow), both depicted against a red background. The arms of the goddess lay down along the body. Exceptionally, the palms of her hands are not turned upwards, as if embracing the mummy (cf. inner case from A.60-Fig. 301). The feet are naturalistically rendered, displaying the fingers of the right foot only.

A symmetrical composition flanks the goddess displayed in four secondary registers. The first one depicts a vulture goddess (facing inwards) resting on a *heb*-bowl with the *ankh*-sign at its feet. The goddess wears the *atef*-crown (white) and the *nekhakha*-flail on the back. Follows a coiled solar cobra resting on a pile composed of a *pet*-sign and a *heb*-bowl. A standing mummiform falcon-headed god (facing outwards) flanks the legs of the goddess. He wears the *atef*-crown and grasps a long coiled snake. Flanking the feet of the goddess, short labels address the formula ‘*Giving life every day forever*’.

The third register of the floorboard is depicted below the feet of the goddess. A symmetrical centrifugal composition is displayed involving two mummiform deities seated on *hwt*-thrones resting on a single *heb*-bowl. The snake-headed gods have divine beards, wear the sun disk and grasp long coiled snakes.

The fourth register depicts a symmetrical composition. At the centre, the sun disk rises above the bearded heads of two standing serpent gods (centrifugally oriented). On the left, the composition is too darkened but on the right side is still possible to detect a standing mummiform goddess adorned with a long wig. She faces inwards.

Footboard

The decoration of the footboard is darkened but reveals a cryptic composition featuring a squatting hare entirely involved by the body of the Ouroboros (Fig. 57). Hieroglyphic signs are cryptically depicted against the starry sky, alluding to ‘*The One who dwells in the Duat*’. The composition rests on a *heb*-bowl.

Inscriptions

The texts are written on a yellow background. Long bands of inscriptions (Inscriptions 1–2) run along the upper edges, springing from a central motif, the *nsw*-sign, at the centre of the headboard (Fig. 49). The texts are outlined in red and coloured green, blue and red. Calligraphy tends to be cursive. In both texts the space reserved for the name of the deceased was left blank.

Inscription 1

h̄tp-dī-nsw R^c-tm, Wsir nbt-pr, šmcyt n Īmn-R^c nsw ntrw [Space left blank for the name]. *dd.s: h̄z Wsir, h̄nty Īmnty^w, [nb] nh̄h, hr[y] tp n i[g]rt[?], Pth-skry, nb štyt, Īnw^w, nb t̄z-dsr, Psdt im[yt] rsy, mh̄t, imntt, isbt, imyt pt, imy[t] t̄z, imy[t] m dw̄zt, dī.sn prt-h̄rw t, hn̄kt, k̄z^w, ʔpdw, h̄t-nb[t] nfr[t] w^cb[t], h̄t-nb[t] nfr[t] ndmt, h̄t-nb[t] pt, t̄z, dw̄zt nty [m] db̄zt.*

An invocation offering that the king gives to Re-Atum. The Osiris, the mistress of the house, the chantress of Amun-Re king of the gods [space left blank for the name]. She says: ‘Oh Osiris, foremost of the Westerners, (lord) of eternity, chief of Igeret[?], and Ptah-Sokary lord of the shetyt-shrine, and Anubis lord of the sacred land, and the Ennead who is in the south, in the north, in the west and in the east, who is in the sky, in the earth and in the Duat. That they may give an invocation offering consisting of bread and beer, oxen and fowl, everything good and pure, everything good and sweet, everything from the sky and the earth, the Duat and [of] who[m?] is [in] the sarcophagus’.

Inscription 2

h̄tp-dī-nsw Pth-skryt, nb š[tyt], Wsir nbt-pr, šmcyt n Īmn-R^c nsw ntrw [Space left blank for the name]. *dd.s: ind [hr].t[n], ntrw, ipw[y], Psdt imy[t] igr̄t[?], ntrw sd̄ryw nty[sis̄] int, t̄z sb̄h̄wt š̄t̄wt nty [sic] h̄nty r h̄ryw, im[y] t̄z, im[y] db̄t, h̄nty int[yw?] š̄t̄z[t] dw̄zt. dī.sn prt-h̄rw t, hn̄kt, k̄z^w, ʔpdw, h̄t-nb[t] nfr[t] w^cb[t], h̄t-nb[t] nfr[t] ndmt, h̄t-nb[t] pt, t̄z, dw̄zt š̄t̄z[t].*

An invocation offering that the king gives to Ptah-Sokar, lord of the mysterious place. The Osiris, the mistress of the house, the chantress of Amun-Re king of the gods [space left blank for the name]. She says: ‘Hail to you/these gods, this Ennead who is in Igeret[?], the gods who sleep in the valley, (in) these secret portals which are before those who are above, who are [in] the earth, who are in the sarcophagus and in front of the secret valley in the Duat. That they may give an invocation offering consisting of bread and beer, oxen and fowl, everything good and pure everything good and sweet, everything from the sky, the earth and the mysterious Duat’.

Only two columns of inscriptions figure on the case (Inscriptions 3 and 4), both dividing *Vignette 1* from the seamless decoration of the sides. Both columns are bordered within two vertical block friezes and face the headboard. The hieroglyphs are outlined in red and painted in green, blue and red.

Inscription 3

Īnk n̄tr ʿz ḥnty ʿst

I am the great god, foremost of the mound.

Inscription 4

Īnk n̄tr ʿz ḥnty ʿst

I am the great god, foremost of the mound.

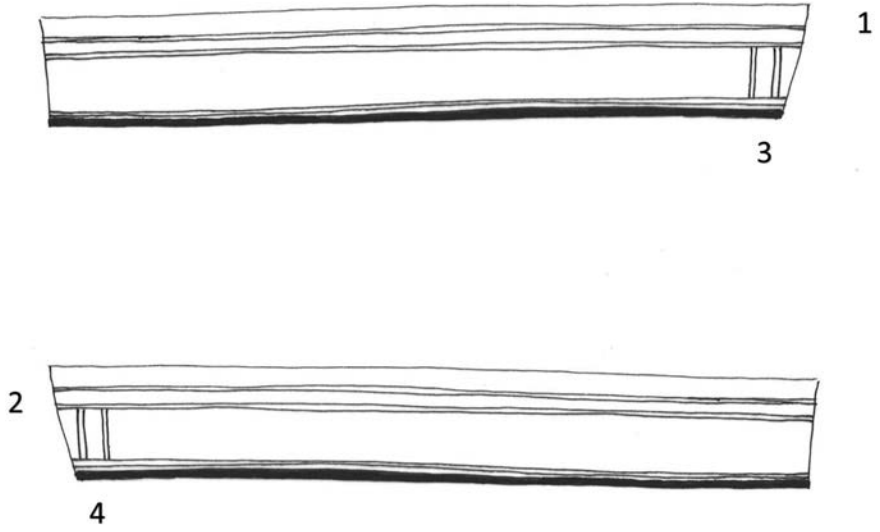
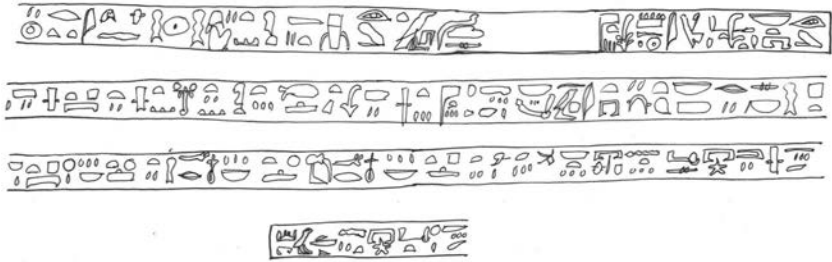

FIGURE 46 Inner case (A.15). Inscriptions numbered, see Figs. 47-48



1



2

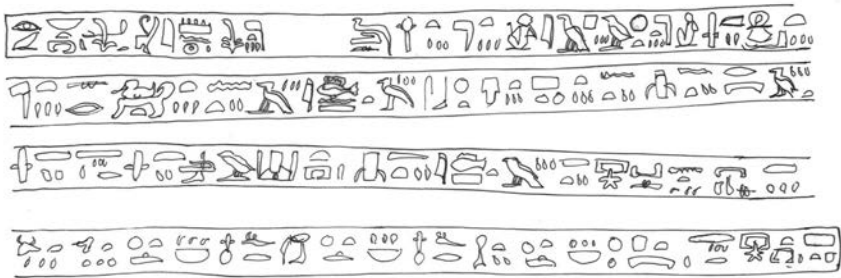

FIGURE 47 Inner case (A.15). Inscriptions 1-2

3



4



FIGURE 48 Inner case (A.15). Inscriptions 3-4



FIGURE 49 Inner case (A.15). Headboard (above), footboard (below)



FIGURE 50
Inner case (A.15).
Left side



FIGURE 51 Inner case (A.15). Left side, upper section



FIGURE 52 Inner case (A.15). Left side, lower section



FIGURE 53
Inner case (A.15). Right side



FIGURE 54
Inner case (A.15).
Right side, upper
section



FIGURE 55
Inner case (A.15). Right side, lower section



FIGURE 56 Inner case (A.15). Interior decoration



FIGURE 57 Inner case (A.15). Interior decoration. Headboard (above), footboard (below)

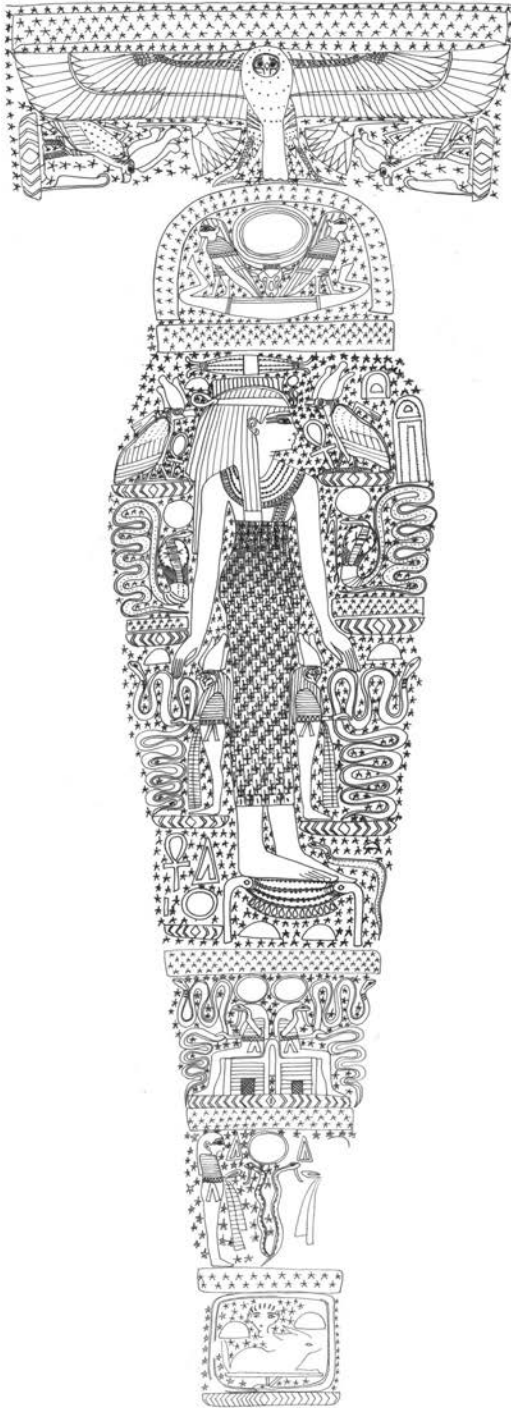

FIGURE 58
Inner case (A.15). Interior decoration. Headboard, floorboard and footboard (drawing)

5. Mummy-Cover

Museum inventory number: 9534

Length: 176 cm; Width: 45,5 cm

Wood, plaster, paint and varnish.

Decorated with multicoloured paintwork and profuse use of moulded plaster, varnished.

The reverse side is undecorated.

The object is preserved in good condition. The plaster collapsed in several areas, mainly on the headboard and the footboard.

The object was restored in the workshops of Florence Museum in 1957–1958.¹

Iconography

Headboard

A large multicoloured headband decorated with lotus petals and geometrical motifs adorns the wig. A large bunch of three lotus flowers and four buds hangs down over the forehead (Fig. 62).

The face is finely carved. The skin is yellow and the contours of the eyes and eyebrows are outlined in black. The pupils (black) are painted against a white background. The lips, nostrils and eye-lids are outlined in red.

The round earrings are painted (not moulded) and decorated with multicoloured rosettes.

The wig is decorated with a checkered pattern.

Upper Section

The breasts figure below the lappets of the wig featuring small rosettes to suggest the nipples. The hands, open and crossed over the chest, are carved in wood and painted yellow. The fingers and nails are outlined in red. The elbows are hardly visible but it is possible to detect a multicoloured lotus flower. The forearms are completely hidden under the floral collar (Fig. 62).

The area comprised between the lappets of the wig display a short collar composed of six transversal bands decorated with alternating pearl-beaded motifs.²

¹ Bosticco 1958, 10–11.

² See Sousa 2018b, 59.

The large floral collar covers part of the abdomen, displaying eight bands decorated with different patterns: checkered motifs (4th, 6th, 8th bands), buds on reeds (3rd, 7th bands), lotus petals (5th band) and lotus flowers intertwined with acacia flowers (1st band).

On the chest, between the breasts and the hands, lies a pectoral depicting a winged scarab (moulded) holding up a solar disk flanked by cobras. The *shen*-ring figures between its hind legs.

Central Panel

The central panel displays eight registers featuring symmetrical compositions (1st, 3rd, 5th, 7th registers) intertwined with large depictions of a winged goddess (2nd, 4th, 6th, 8th registers). The layout typically used in the lower section was omitted in this object. Some of the motifs of the composition are slightly moulded in plaster to suggest relief, such as the scarabs, the *tjet*-signs, the bodies of the enthroned gods, the *hwt*-thrones, some elements of the frieze and the body of the winged goddess (Fig. 63).

In the **first register** the nuclear block features a sacred scarab holding up a solar disk flanked by cobras and *tjet*-signs. The scarab rises from a transversal sign and holds the *shen*-ring with the hind legs. This nuclear block is flanked by centrifugal blocks featuring the enthroned mummiform Osiris grasping the royal scepters. He has divine beard and wears the *hedjet*-crown. The register is completed with centripetal blocks displaying a winged goddess squatted on a high platform outstretching her wings towards Osiris. The avian manifestation of the deceased rests under her wings, wearing the divine beard. The goddess is crowned with a sun-disk encircled within a cobra wearing the *hedjet*-crown. A sacred vulture (wearing the *hedjet*-crown—only on the right side) rests above her wings, with the *was*-scepter at its feet. Short labels refer to 'Neith' while others form full sentences such as '*Praising the great god who is in the beautiful*'.

In the **second register** a large kneeling goddess outstretches her wings towards both sides of the object. A geometrical frieze is arranged above the wings of the goddess.

In the **third register** the composition of the nuclear block and the centrifugal block are kept, but the centripetal blocks feature a solar winged cobra resting on a high platform. The goddess outstretches her wings towards Osiris, while embracing the *udjat*-eye. Moreover, a standing mummiform god was added in this register. Short labels form the title '*Neith, the goddess who is in the Duat*'.

The **fourth register** recalls the composition of the second register.

In the **fifth register** the centrifugal blocks were excluded (Cf. Lid inner coffin—7th register). The centripetal blocks depict the avian manifestation of

the deceased resting on a reed mat with a feather at his feet. The *ba*-bird has a divine beard and wears the *menat*-counterpoise and a sun-disk. Behind him, figures the winged *udjat*-eye with a pending cobra wearing the *atef*-crown and the *ankh*-sign hanging from its neck. Short labels form the formula '*Praising the one who is in the beautiful Thebes*' (left side).

The **sixth register** depicts the large winged goddess, while in the **seventh register** the nuclear block is now flanked by centrifugal blocks depicting a squatted mummiform Osiris, grasping a feather. He has divine beard and wears a sun disk on his head. The centripetal block depicts the winged *udjat*-eye with a pending cobra wearing the *hedjet*-crown and the *ankh*-sign hanging from its neck. Short labels form the title '*The one who is in the beautiful Thebes*'.

The **eighth register** depicts the large winged goddess.

Footboard

Unlike most of the mummy-covers from Lot v, this object is provided with a footboard (Fig. 63). The central partition is inscribed with three columns of text (Inscription 1), bounded by block-friezes. The lateral partitions display mummiform hippopotamus-headed gods under a vaulted shrine. These deities stand on a *heb*-bowl depicted over a transversal band inscribed with the title '*Venerable one*'. The lower edge is decorated with a geometrical frieze.

Inscriptions

The central partition of the footboard is inscribed with three columns of text (Inscription 1). The hieroglyphs are written against a yellow background. In the first column the space reserved for the name of the deceased was left blank.

Inscription

(col. 1) *ink, Wsir nbt-pr, šm·yt [n] Ímn-Rs, nsw-ntrw* [Space left blank for the name]. *dd.[s]: 'h3y*, (col. 2) *mwt[.i] Nwt, psš.t dnḥwy.t ḥr[.i, dī.t] wnn[.i]* (col. 3) *mi iḥmw-sk, iḥmw-wrđ'*

(col. 1) *I am the Osiris, the mistress of the house, the chantress of Amun-Re king of the gods* [Space left blank for the name]. [*She*] *says: 'Oh* (col. 2) [*my*] *mother Nut, stretch your wings over* [*me and let me*] *be* (col. 3) *like the Imperishable stars, (and) (like) the Unweary stars*'.

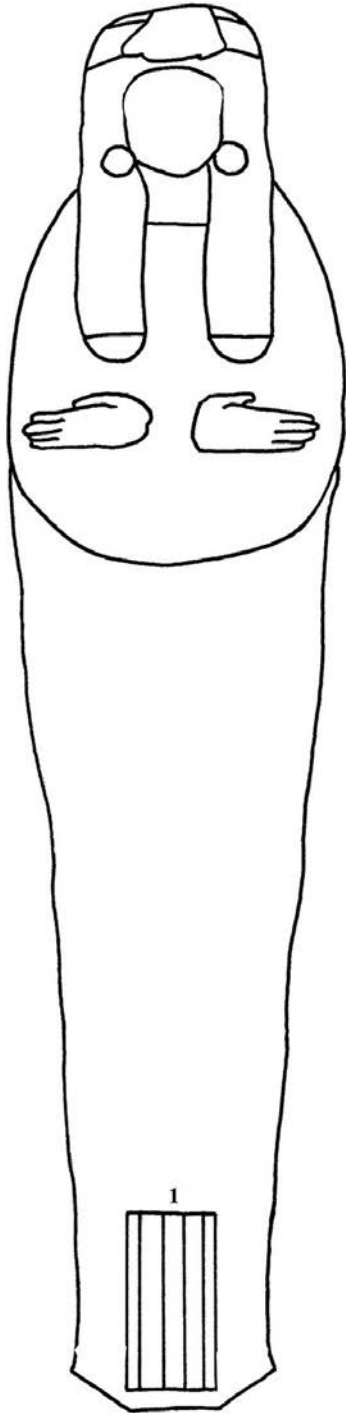

FIGURE 59
Mummy-cover (A.15). Inscriptions

1

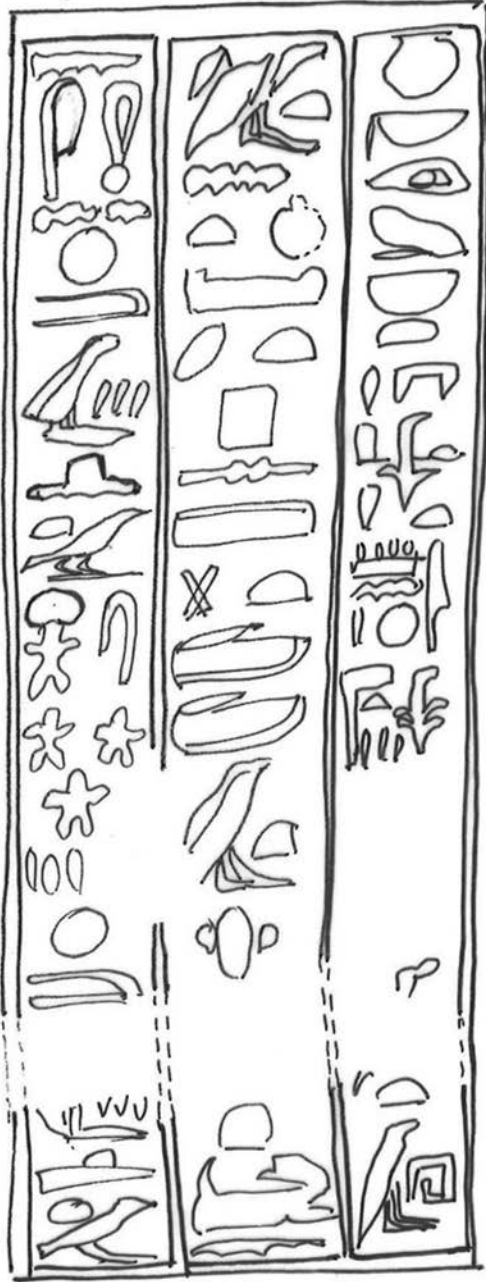

FIGURE 60
Mummy-cover (A.15). Inscription 1



FIGURE 61
Mummy-cover (A.15)



FIGURE 62 Mummy-cover (A.15). Headboard and upper section



FIGURE 63
Mummy-cover (A.15). Central
panel

Coffin Set of Tauhenut (A.20)

Summary description: Inner anthropoid coffin (6–7) and mummy-cover (8), both anonymous.

Archaeological context and dating: The coffin set was found in the main gallery of Bab el-Gasus. Together with three other coffin sets (A.19, A.18 and A.24) it formed a barrier (the third of this kind) to block the way to the innermost areas of the tomb. It was found under the coffin set A.19 and perhaps for this reason it was heavily damaged on the lid.

The scheme of decoration recalls the layout from the first half of the 21st Dynasty.

The burial assemblage included a shroud and an inscribed linen cloth decorated with an effigy of Osiris.¹ The mummy was adorned with braces, a pair of linen mittens on each arm and a wax embalmer's plaque (Cairo JE 36355).² Four wax figures of the Sons of Horus were placed inside the body.³ A Book of the Amduat (Cairo JE 36464) was found between the legs while a Book of the Dead (Cairo SR VII 10270)⁴ was probably enclosed within an Osiris statue.⁵

Name and titles of the owner: The coffin set is anonymous. The inner coffin bears generic titles, such as *Mistress of the House*, *Songstress of Amun-Re* and *Great favorite*. The mummy-cover did not provide any name or title. Nevertheless, Daressy found a cloth inside the case bearing a hieratic inscription referring to the *Chantress of Amun Nesitanebisheru*.⁶ During the examination of the mummy the name 'Tauhenut' was read.⁷

1 Aston included in the burial equipment of this mummy a collection of blue faience shabtis. However, Florence N. Inv. 6167 is from the Royal Cache such as the statuettes from Cortona (N. 9,17, 28, 133, 140). See Aston 2009, 167 n. TG 693.

2 Daressy 1907, 23.

3 Daressy and Smith 1903, 155.

4 Niwiński 1989, 288 n. 99.

5 Niwiński 1989, 281 n. 80.

6 Daressy 1907, 23.

7 Daressy and Smith 1903, 155.



FIGURE 64 Coffin set (A.20)

6. Lid

Museum inventory number: 8522

Length: 179 cm; Width (max): 49 cm

Wood, plaster, paint, varnish.

Decorated with multicoloured paintwork.

The reverse side of the object is undecorated.

The object presents several cracks, the major one situated on the left side of the headboard, but the decoration is well preserved. The footboard collapsed.

Iconography

Headboard

A multicoloured headband decorated with floral patterns (persea-tree buds) adorns the wig (blue). A bunch of a lotus flower and buds hangs from the crown of the head (Fig. 69).

The face is crudly carved and painted in yellow. The eyes and eyebrows are outlined in black. The pupils (black) are painted against a white background. A red line is traced above the eye to suggest the eye-lid. The lips are also outlined in red.

The earrings are moulded and decorated with rosettes. The lappets of the wig display multicoloured binding bands decorated with a beaded motif.

Upper Section

The breasts (painted, not moulded) figure below the lappets of the wig featuring rosettes to suggest the nipples (Fig. 69).

The hands are open, painted yellow and crossed over the chest. Against the usual practice, the hands are not carved in wood but entirely moulded in plaster. Most of the fingers are lost, with exception of the thumbs.

The arms are decorated with red lines suggesting linen stripes and the elbows are decorated with a lotus flower (multicoloured). The forearms display bracelets, three of them featuring geometrical patterns (multicoloured) and two others composed of small *udjat*-eyes.

The area comprised between the lappets of the wig presents a short collar featuring five floral bands. The large floral collar displays four bands decorated with a variety of patterns: mandrake flowers (4th band), geometrical motifs (3rd band), cornflowers (2nd band), and lotus intertwined with corn-

flowers (1st band). The clasps of the floral collar are decorated with a falcon head.¹

On the chest, between the breasts and the hands, lies a large winged scarab holding up the solar disk flanked by cobras.

Central Panel

The central panel displays two registers (Fig. 70). The tableau is bounded by transversal bands of text (Inscriptions 3–4).

The first register shows a symmetrical composition. The nuclear block features a pectoral shaped as a winged ram-headed scarab holding up a solar disk. The sun disk is flanked by *udjat*-eyes and *neb*-baskets. This pectoral hangs from a necklace hidden under the floral collar. This composition is flanked by centrifugal blocks featuring a kneeling mummiform Osiris grasping the *heqa*-scepter and wearing the *hedjet*-crown. The register is completed with centripetal blocks featuring a winged coiled cobra (identified as Neith) wearing the solar disk. The goddess outstretches her wings towards Osiris, embracing the *udjat*-eye (right side) or the *shen*-ring (left side).

The second register displays a large winged goddess squatted on a reed mat outstretching her wings towards the sides. The name 'Nut' figures on her head. Two winged cobras are depicted above the arms of the goddess, forming a symmetrical centripetal composition. *Udjat*-eyes are depicted between their wings. The same symbol is depicted under the wings of the goddess Nut.

Lower Section

The lower section is divided into two longitudinal partitions by a double column of hieroglyphs (Inscriptions 1–2). Each partition is divided into three registers by transversal bands of text (Inscriptions 3–10).

In the first register a mummiform god is seated on a throne resting on a *heh*-bowl (Fig. 71). The god has a curled beard, grasps the royal scepters and wears the *hedjet*-crown. The winged *udjat*-eye with a pending cobra faces the god. The cobra wears the sun disk (right side) or the *dšrt*-crown (left side) and carries the *ankh*-sign on its neck.

In the second register the avian manifestation of Ptah-Sokar rests on a divine standard with a feather at his feet. The avian god wears the *atef*-crown and the *menat*-counterpoise. The *udjat*-eye is depicted behind him and the name 'Sokary' is written before him.

The third register is badly damaged, but remains of the winged *udjat*-eye can be found, showing that it was the main subject of the vignette.

¹ For the identification of these motifs see Sousa 2018b, 59/97.

Footboard

Lost.

Inscriptions

Two longitudinal inscriptions (Inscriptions 1–2) run down the centre of the lid, dividing the lower section into two partitions. The inscriptions are centripetally oriented. As the footboard collapsed, these inscriptions are now incomplete. The hieroglyphs are outlined in red and some details are painted in black, green, red and blue. The background is yellow. Some of the hieroglyphs used in these inscriptions are sophisticated and finely executed, such as the determinative of the barque (Gardiner P 3), the *wepet-renpet*-sign (Gardiner F 14, combination of F 13 and M 4) and the determinative of the man with an axe (Gardiner A 14*). The symmetrical display of the hieroglyphs of both inscriptions creates interesting visual effects, particularly in the writing of the name of Osiris, where the eyes suggest a human face seen frontally.

Inscription 1

dd mdw in Wsir, 3h pw m3c-hrw: pr[. t] r pt, d3[. t] b13, [sn]sn[. t] m sb3w nw pt, ir[.] tw n. t hknw m w13'

Words to be spoken by Osiris, this akh, the justified one: "May you ascend to the sky, may you cross the firmament and may you mingle with the stars of heaven. May one make praise to you in the sacred barque [---]".

Inscription 2

dd mdw in Wsir, 3h pw m3c-hrw: 'c[k[. t] r dw3t, m33[. t] imy.st, m hrw wpt-rnpt, ir. t (sn t3(?) m b1st(?) [---])'

Words to be spoken by Osiris, this akh, the justified one: "May [you] enter the Duat and see what is inside it, on New Year's Day. May you "kiss the earth" (in(?) [---])".

Short transversal inscriptions divide the lower section in several registers (Inscriptions 3–10). All of them are centripetally oriented and present variations of the same text. The last two texts, placed on the footboard, are almost completely lost but they still preserve references to Nephthys and perhaps Isis.²

² In the part of the edges corresponding to these inscriptions we can read the hieroglyphs "divine mother" (common epithet of Isis, on the left side) and "Nephthys" (on the right side).

Inscriptions 3–4*Imꜣhy (hr) Wsir, hkꜣ dt, ntr ꜣ**The venerable one before Osiris, the ruler of eternity, the great god.***Inscriptions 5–6***imꜣhy (hr) Pth-skr**The venerable one before Ptah-Sokar***Inscriptions 7–8***Imꜣh[y] [hr] wdꜣt, nb dwꜣt**The venerable one before the Udjat-eye, the lord of the Duat.***Inscription 9***[imꜣhy (hr)] Nbt-ḥwt**[The venerable one before] Nephthys***Inscription 10***[imꜣhy (hr) ꜣst ?] mwt ntr**[The venerable one before Isis?], the divine mother*

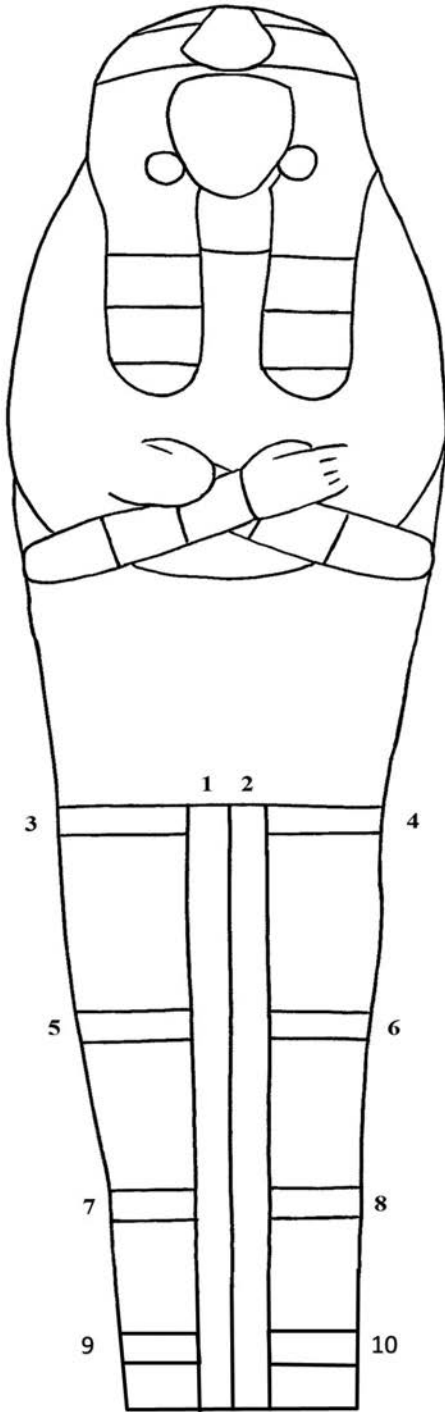

FIGURE 65
Lid (A.20). Inscriptions

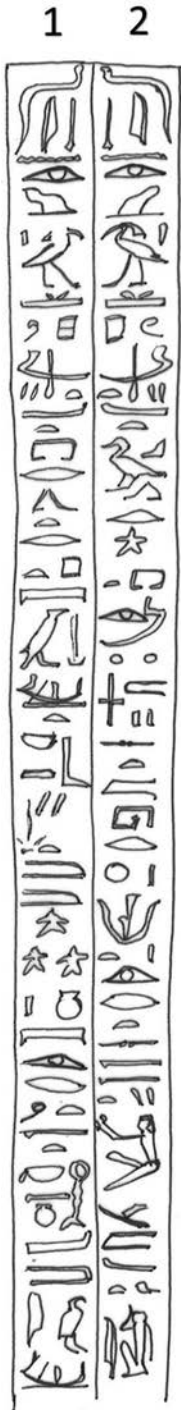

FIGURE 66
Lid (A.20). Inscriptions 1-2



FIGURE 67 Lid (A.20). Inscriptions 3–10



FIGURE 68
Lid (A.20)



FIGURE 69 Lid (A.20). Headboard and upper section



FIGURE 70 Lid (A.20). Central panel



FIGURE 71 Lid (A.20). Lower section

7. Case

Museum inventory number: 8522

Length: 179 cm; Width (max): 49 cm; Depth: 26 cm

Wood, plaster, paint.

Decorated with multicoloured paintwork.

The footboard remained undecorated. The interior is undecorated.

The exterior decoration is preserved in relatively good condition.

Iconography (Exterior)

The upper edge does not display friezes or inscriptions. The vignettes are bounded by columns of hieroglyphic texts (Inscriptions 1–14). The lower edge is decorated with a thick horizontal band (black).

Headboard

The headboard is composed of a tripartite panel, with the sides (*Vignettes 2–3*) centripetally oriented.

The *Vignette 1* (centre) shows a large *tjet*-sign outlined in red and blue and adorned with two flowers. It is flanked by two poles of the West (Fig. 74).

The *Vignettes 2–3* are symmetrical, displaying the avian manifestation of Ptah-Sokar resting on a divine standard with a feather at his feet. The avian god wears the *atef*-crown. The winged *udjat*-eye is depicted behind him, with a pending cobra wearing the *hedjet*-crown. A single column of hieroglyphs is written before the avian god, bearing the name 'Sokary'.

Left Side

The upper section is decorated with two vignettes (*Vignettes 4 and 5*) forming a single scene depicting the god Thoth before the recumbent god Osiris (cf. *Vignettes 10–11*).

The *Vignette 4* depicts the ibis-headed god Thoth (facing the footboard) holding the pole of the West (Fig. 76).

In the *Vignette 5* Osiris is depicted laying on a ritual bier provided with a beaded mattress and decorated with lion legs and tail. He has a large royal beard and wears the *hedjet*-crown with floating red streamers. A winged cobra is depicted flying over his body, with its outstretched wings embracing the *udjat*-eye. Under the ritual bier figure a variety of royal insignia (scepters and crowns) and food offerings.

The lower section is composed of four vignettes.

In the *Vignette 6* the deceased (facing the footboard) stands under a vaulted pavilion, wearing a white festive garment (Fig. 77). Her head is adorned with the ointment cone and a lotus bud. Before a short inscription is written: '*Giving an offering for your ka*'.

The *Vignette 7* shows the *Ta-wer*-totem adorned with a double-feathered solar headdress standing on the horizon. The totem is flanked by *udjat*-eyes and two *nefer*-signs depicted on *heb*-bowls (above) and two coiled winged cobras resting on a pile of reed mats and *heb*-bowls (below). The winged cobras wear the *hedjet*-crown and embrace the *udjat*-eye (Fig. 77).

The *Vignette 8* displays a centripetal composition depicting three mummiform gods standing on a coiled serpent (Fig. 78). The central ram-headed mummiform deity faces the headboard. He is flanked by a lion-headed god (right) and a jackal-headed deity (left). Above their heads small flames are found.

The *Vignette 9* shows the sacred cow in her Theban shrine. The goddess Hathor is couched on a platform, facing the headboard. She is adorned with the hathoric headdress and the sistrum. Before the deity, a short label refers to the '*Mistress of the West*' and at her back a winged cobra embraces the *udjat*-eye. On the left, the tomb is depicted on the desert cliff, with the name 'Osiris' inscribed over the door.

Right Side

The upper section is decorated with two vignettes forming a single scene depicting the god Thoth before the recumbent god Osiris (cf. *Vignettes 4–5*).

The *Vignette 10* shows the ibis-headed god Thoth holding the pole of the East (Fig. 80). A short label refers to the 'great god'.

In the *Vignette 11*, Osiris lies on the ritual bier equipped with royal insignia and offerings. A winged cobra embracing the *shen*-ring flies above him. The winged *udjat*-eye is depicted before the god, with a pending cobra bearing the *ankh*-sign on its neck.

The lower section of the right side is also composed of four vignettes (cf. *Vignettes 6–9*).

The *Vignette 12* recalls the composition of *Vignette 6*, but in this case the deceased offers an ointment vessel and holds the *ankh*-sign. She is depicted under a vaulted pavilion (Fig. 81).

The *Vignette 13* shows a composition featuring two registers divided by the *pet*-sign: on the upper register the solar barque sails heading the footboard and carries the winged scarab holding up the solar disk flanked by cobras. On each side of the barque, short labels refer to the '*Lord of the Duat*' (right) and '*Great*

god' (left). On the lower register the body of a coiled snake is wounded by five knives (red).

The *Vignette 14* displays a centripetal composition depicting three mummiform gods standing on a coiled serpent (Fig. 82). The central ram-headed mummiform deity is facing the headboard. He is flanked by a lion-headed god (right) and a jackal-headed deity (left) (cf. *Vignette 8*).

The *Vignette 15* depicts the *ba-bird* resting next to the sycamore tree goddess. The avian manifestation of the deceased raises her arms to drink the water offered by the sycamore deity. The goddess is squatting among the leaves, clad in a tight green dress and identified by the name 'Nut' written on the trunk of the sacred tree. Behind the deceased, a column of hieroglyphs contains the formula 'Give water for this ba'.

Footboard

The footboard remained undecorated (Fig. 74).

Inscriptions

The texts are written in columns bordered by vertical lines (black). The signs were outlined in red against a yellow background and coloured with other pigments (green, blue and red). The calligraphy of these texts is more cursive than in the texts inscribed on the lid.

The left side displays 7 inscriptions (Inscriptions 1–7). Inscriptions 1, 3, 6 and 7 face the headboard, while Inscriptions 2, 4 and 5 face the footboard. It is noteworthy that a fifteenth column is displayed next to the footboard, but instead of an inscription it displays a large depiction of the pole of the West.

Inscription 1

dd mdw in Pth-skry-Wsir nb dw:t.

Words to be spoken by Ptah-Sokar-Osiris, lord of the Duat.

Inscription 2

(col. 1) *dd mdw in dhwtj, nb mdw-ntrw, sš m:t (col. 2) n Psdt-ꜣ[t]: 'nḥ R, mt štyw, r-nb'*

(col. 1) *Words to be spoken by Thoth, lord of the divine words, scribe of Ma'at*
(col. 2) *of the great Ennead: 'Re lives, the turtle dies every day'.*

Inscription 3

dd mdw in Mrty, ntr nfr, nb dwꜣt

Words to be spoken by Merety, the perfect god, lord of the Duat.

Inscription 4

(col. 1) *dd mdw in Wsir, nbt pr, šmꜣyt n Īmn* (col. 2) *ꜣh ikr, mꜣꜣ-ḥrw ḥr mꜣꜣ-ḥrw*

(col. 1) *Words to be spoken by the Osiris, the mistress of the house, the chantress of Amun, (col. 2) the excellent akh, justified before the justified ones.*

Inscription 5

(col. 1) *ind-ḥr k Wsir, nb nhḥ, ir dt* (col. 2) *ntr ꜣ, ḥnty-Īmnt nfrt m ꜣbdw* (col. 3) *nb nrw ḥry-tp igrt, ḥkꜣ ꜣnh.w* (col. 4) *nb Īmntyw, pr m ht[.f] ḥdt ḥry-tp*

(col. 1) *Hail to you Osiris, lord of eternity, who makes everlasting time, (col. 2) great god foremost of the beautiful West in Abydos, (col. 3) lord of dread chief of the realm of the dead, the ruler of the living, (col. 4) lord of the westerners, who goes forth from (his?) body (?).*

Inscription 6

(col. 1) *dd mdw in nbw nhḥ, ḥꜣtyw [n] dt* (col. 2) *[Psḏ]t-ꜣꜣt, nb ḥrt-ntr, ḥtpw [m] dbꜣt*

(col. 1) *Words to be spoken by the lord of eternity, the foremost of the everlasting time, (col. 2) the great Ennead, lord the necropolis and those who rest in the sarcophagus.*

Inscription 7

(col. 1) *dd mdw in ḥwt-ḥr, ḥry[t]-tp Īmnt, ḥnty[t] tꜣ-dsr* (col. 2) *ḥnwt ḏw pfy, di.s ḥtp*

(col. 1) *Words to be spoken by Hathor, chief of the West, the foremost of the Sacred Land, (col. 2) the mistress of this mountain, may she give offering(s).*

The right side displays 7 inscriptions (Inscriptions 8–14). Inscriptions 8, 10, 13 and 14 face the headboard, while Inscriptions 9, 11 and 12 face the footboard. The fifteenth column displays a large depiction of the pole of the West.

Inscription 8

(---) *dīf* (---)

(---) *that he may give* (---)

Inscription 9

(col. 1) *dd mdw in dḥwty, nb mdw-ntr, sš* (col. 2) *mꜣt n Psdt-ꜣ: ‘nh [R^c], mt štyw, [r^c]-nb’*

(col. 1) *Words to be spoken by Thoth, lord of the divine words, the scribe of Ma’at*
(col. 2) *of the Great Ennead: ‘[Re] lives, the turtle dies’ every [day].*

Inscription 10

dd mdw in Mrty, ntr nfr, nb dwꜣt nb[...]

Words to be spoken by Merety, the perfect god, lord of the Duat, lord [of ...]

Inscription 11

(col. 1) *Wsir nbt-pr šmꜣyt n Īmn-R^c nsw ntrw* (col. 2) *ḥsyꜣ ꜣt, mꜣ-ḥrw n[sic, read m] Wꜣst*

(col. 1) *The Osiris, the mistress of the house, the chantress of Amun-Re king of the gods,* (col. 2) *the great favourite, justified in Thebes.*

Inscription 12

(col. 1) *ind-ḥr k R^c-tm-ḥpꜣy, it* (col. 2) *ntrw, irr dt.f, kmꜣ ḥꜣ.f,* (col. 3) *sꜣ-sw r ntrw nbw, dīw-sw* (col. 4) *m pt r ntry bꜣ.f*

(col. 1) *Hail to you Re-Atum-Khepri, father* (col. 2) *of the gods, who made his own body, who created his own flesh,* (col. 3) *who made himself greater than all the gods, who put* (col. 4) *himself in the sky, so that his ba is divine!*

Inscription 13

(col. 1) *dd mdw in nbw nhḥ, ḥꜣtyw n dt* (col. 2) *Psdt-ꜣt, nb ḥrt-ntr, ḥtp n[=m] dbꜣt*

(col. 1) *Words to be spoken by the lords of eternity, the foremost of everlastingness,*
(col. 2) *the great Ennead, lord of the necropolis, [and] those who rest in the sarcophagus.*

Inscription 14

(col. 1) [*dd mḏw i*]n Nwt, wrt, mst ntrw (col. 2) [*irt*] R; ḥkst idby, dī.s ḥtp ḏfꜣw

(col. 1) [*Words to be spoken*] by Nut, the great one, who gave birth to the gods,
 (col. 2) [*the eye of*] Re, the ruler of the Two Banks, so that she may give offerings
 and provisions.

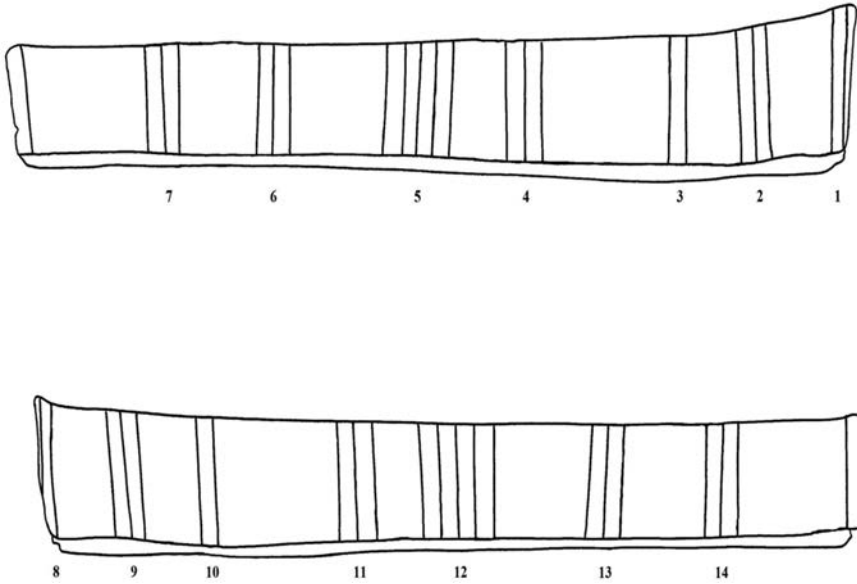

FIGURE 72 Case (A.20). Inscriptions

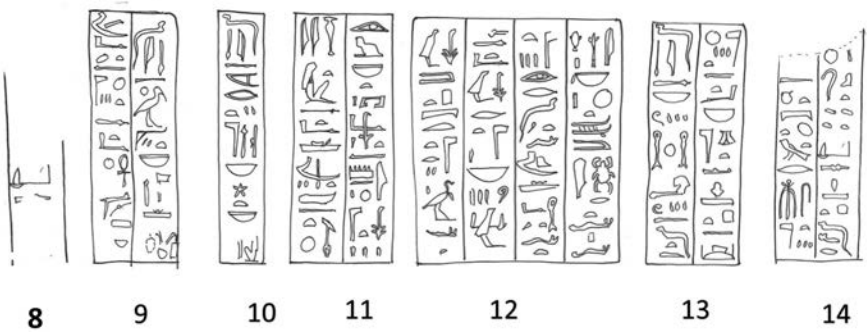
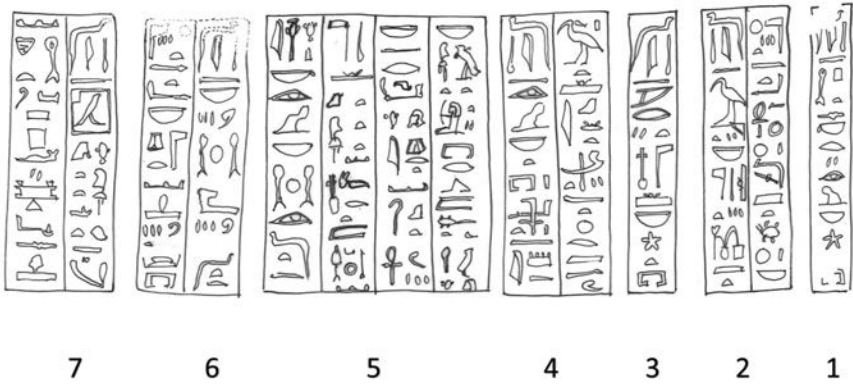

FIGURE 73 Case (A.20). Inscriptions 1-14



FIGURE 74
Case (A.20). Head-
board (above),
footboard (below)



FIGURE 75
Case (A.20). Left side



FIGURE 76 Case (A.20). Left side, upper section



FIGURE 77 Case (A.20). Left side, middle section



FIGURE 78 Case (A.20). Left side, lower section



FIGURE 79
Case (A.20). Right side



FIGURE 80 Case (A.20). Right side, upper section



FIGURE 81 Case (A.20). Right side, middle section



FIGURE 82 Case (A.20). Right side, lower section

8. Mummy-Cover

Museum inventory number: 9476

Length: 161 cm; Width: 34 cm

Wood, plaster, paint and varnish.

Decorated with multicoloured paintwork.

The reverse side of the object is undecorated.

Preserved in relatively good condition. The object is fragmented on the lower edge. The lappets of the wig collapsed.

Iconography

Headboard

A multicoloured headband decorated with persea-tree buds adorns the wig (black). A bunch of lotus flowers hangs from the crown of the head (Fig. 86).

The face is roughly sculpted and painted in yellow. The eyes and eyebrows are outlined in black. The pupils (black) are painted against a white background. A red line is traced above the eye to suggest the eye-lid. The lips are outlined in red.

The nose is broken but the nostrils are preserved. A red horizontal line is visible on the neck, depicting a crease on the throat.¹

The earrings are casted separately and attached to the wig. Only one is left in situ (right side) showing a small multicoloured rosette.

Upper Section

The breasts are not depicted. The hands are moulded in plaster but they are beautifully executed, with the fingers and nails carefully outlined in red. They are depicted open and painted yellow, crossed over the chest. The fingers of the left hand are lost, except the thumb (Fig. 86).

The forearms are decorated with bracelets. Three of them show multicoloured block-friezes, while two others display small *udjat*-eyes. The elbows display lotus flowers while the arms are decorated with the beaded pattern that covers the mummy (fully shown on the lower section—see Fig. 88).

1 See, for example, the objects from A.68: mummy-cover (British Museum, EA 24797) and lid (Kunsthistorisches Museum, ÄS 6267a) in Lacovara, Haynes 2018, 68–69.

The area comprised between the lappets of the wig presents a short collar decorated with a variety of floral patterns (multicoloured).

The large collar features falcon-headed terminals. It displays four bands of floral motifs, decorated with two patterns: persea-tree buds (1st, 3rd bands) and geometrical motifs (2nd, 4th bands). On the chest lies a pectoral in the form of a winged scarab with outstretched wings. It holds up the solar disk flanked by cobras. The pectoral hangs from a necklace hidden under the short collar.

Central Panel

The central panel displays two registers (Fig. 87).

The first register shows a symmetrical composition. The first register shows a symmetrical composition with a pectoral at the centre featuring a winged scarab (black) holding up a solar disk flanked by *udjat*-eyes and a *neb*-sign. The pectoral hangs from a necklace hidden under the large floral collar. This composition is flanked by centrifugal blocks featuring the avian manifestation of Ptah-Sokar resting on a *heb*-bowl with a feather at his feet. The god wears the *atef*-crown and holds the *nekhakha*-scepter. The deity is identified by the name 'Sokary'.

The second register is bounded by a large *pet*-sign. Below, a squatted green-skinned goddess outstretches her wings towards both sides. She is clad with a beaded dress and wears the modium on her head, with a headband. Winged *udjat*-eyes flank her head.

Lower Section

This area is divided into two longitudinal partitions by a single column of hieroglyphs (Inscription 1). Both partitions are decorated with a geometrical pattern recalling the funerary beaded nets (outlined in white against red background) (Fig. 88).²

2 Silvano 1980, 83, 89–92. See also Niwiński 1988, 82. In Lot v, this is the only example of the geometrical decoration in the lower part of the lid. This pattern is rare also in Bab el-Gasus. Other attested examples are the mummy-cover of A.9 (Washington, National Museum of Natural History-Smithsonian Institution, A154955 and A364998: Niwiński 1988, 179 n. 424; the mummy-cover of A.68 (London, British Museum, EA 24797: Niwiński 1988, 177 n. 416) and the mummy-cover of A.135 (Cairo, Egyptian Museum, CG 6126–6128 e 6145–6146: Niwiński 1988, 133 n. 152, Pl. XV B).

Inscriptions

One single column of hieroglyphic text runs down the centre of the lower section (Inscription 1) dividing it into two lateral partitions.

The quality of the writing is fair. Some hieroglyphs are carefully depicted, such as the *akh*-bird (Gardiner G 25), outlined in three different colours. Most of the hieroglyphs are outlined in red and painted in blue, green or red. The text makes an interesting allusion to both types of funerary workshops where mummification was carried out, the 'pure place' (*uabet*) and the 'House of Embalming' (*per-nefer*).

Inscription 1

dd mdw [in][...] h[3] Wsir; 3h pw m3'-hrw hr Inpw hnty sh-ntr, tpy dwf, hnty w'bt, ntr 3, nb t3-dsr, hry-hbt tpy, hry sst3 [m] pr-nfr

Words to be spoken by[], oh, Osiris, this akh justified before Anubis, foremost of the divine shrine, who is on his mountain, foremost of the pure place, great god, lord of the Sacred Land (the necropolis), chief-lector priest, master of the secrets of [the] 'House of Embalming'.

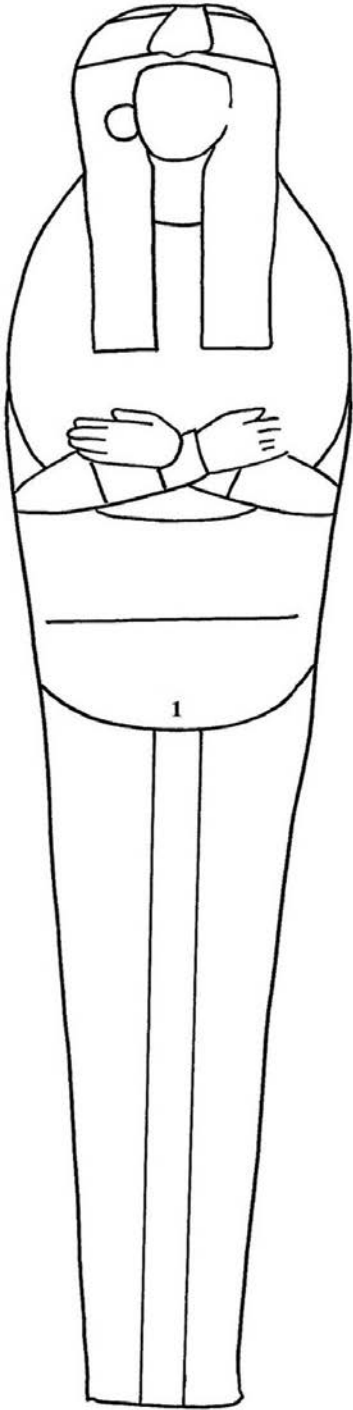

FIGURE 83
Mummy-cover (A.20).

1



FIGURE 84
Mummy-cover (A.20). Inscription



FIGURE 85
Mummy-cover (A.20)



FIGURE 86 Mummy-cover (A.20). Headboard and upper section

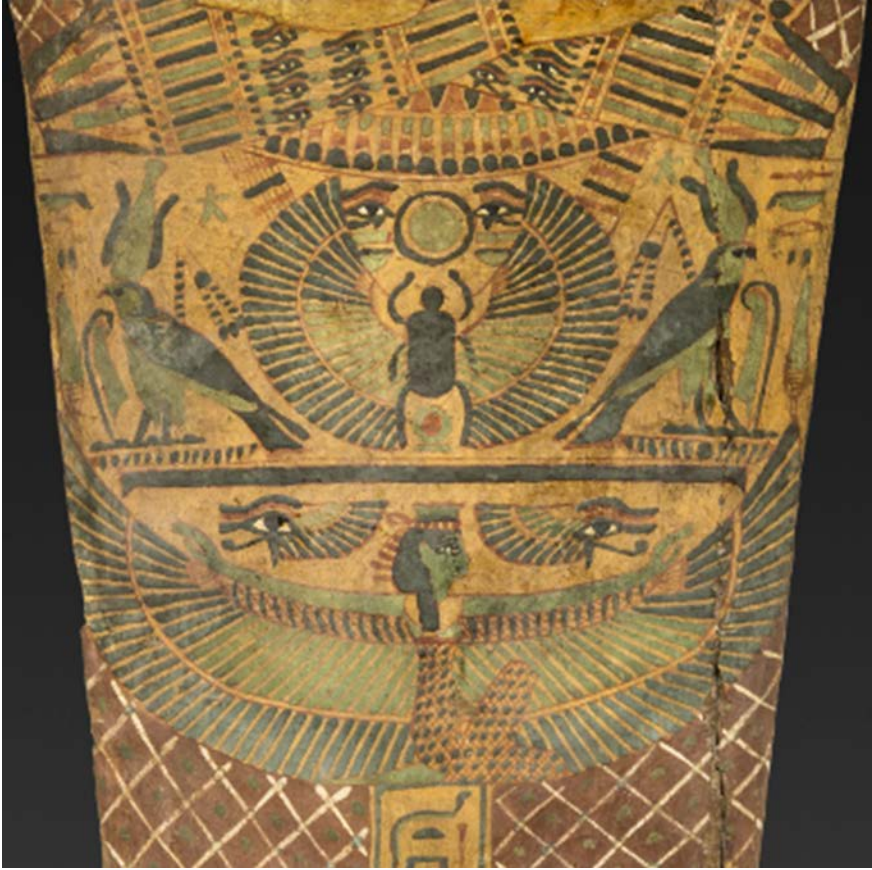

FIGURE 87 Mummy-cover (A.20). Central panel



FIGURE 88
Mummy-cover (A.20). Lower
section

Coffin Set of Khonsumes (A.22)

Summary description: Inner anthropoid coffin (9–10) and mummy-cover (11).

Archaeological context and dating: The coffin set was found in the main gallery of Bab el-Gasus, next to the eastern wall. The scheme of decoration dates from the mid-21st Dynasty.

Name and titles of the owner: The equipment of this coffin set presents traces of usurpation: the name and the title ('Scribe of the State of Amun') of Khonsumes, the first owner, figure intact on the lid (Inscription 1), but in the texts of the mummy-cover (Inscriptions 1–2) this name was erased and the title of a female owner ('Mistress of the house') was inscribed. Note that a name was probably added after the title, but the footboard of the mummy-cover was broken and the name is now lost. Female features had been added on the lid and on the mummy-cover, namely earrings and open hands.



FIGURE 89 Coffin set (A.22)

9. Lid

Museum inventory number: 8527

Length: 184 cm; Width (max): 48 cm

Wood, plaster, paint and varnish.

Decorated with multicoloured paintwork and occasional use of moulded plaster. The reverse side of the object is undecorated. The object presents several cracks on the footboard, but the decoration is well preserved. The hands were striped off from the lid and they are now lost.

The object was restored in the workshops of Florence Museum during the years 1958–1959.¹

Iconography

Headboard

The headband shows the typical geometrical decoration of the ‘crown of justification’.² The tripartite wig is fully decorated with a striped pattern (yellow bands on black background) and display terminals (yellow).

The face is smoothly rendered. The skin is yellow and the contour of the eyes and eyebrows is traced in black. The pupils (black) are painted against a white background. A red line is traced above the eye to suggest the eye-lid. The lips are outlined in red. The earrings are painted, not moulded (Figs. 95–96).

Upper Section

The arms are decorated with a feathered pattern and the elbows show large lotus flowers (multicoloured). A reminiscence of the feathered pattern is found again on the forearms which are otherwise fully decorated with bracelets, some of them showing geometrical patterns (multicoloured), while others feature vignettes (Figs. 95–96). On the right forearm, the bracelet shows the avian form of Ptah-Sokar (moulded) wearing the *atef*-crown, preceded by two cobras wearing the same *atef*-crown. This group is protected by a winged cobra embracing the *shen*-ring and the *udjat*-eye with the outstretched wings. The

1 Bosticco 1958, 13. For other references on this coffin see Saleh Ali (ed.) 1999, 233 n. 68. Guidotti (ed.) 2000, 108–109 n. 33. Roccati and Capriotti Vitozzi (ed.) 2002, 193 n. v1.32. Bresciani et al. 2006, 164–165. Cooney 2011, 32–33.

2 See Sousa 2018b, 52.

cobra goddess wears the sun disk on her head and the name 'Neith' figures before her. The left forearm shows a bracelet decorated with a symmetrical composition. At the centre figures a ram-headed scarab (moulded) rising from a *neb*-sign and holding up the sun disk (moulded). The scarab is flanked by squatted mummiform deities. One holds a feather on the knees and the name 'Hapy' figures before him, while the other wears the *atef*-crown and holds a knife on the knees.

The area comprised between the lappets of the wig presents a short collar with ten bands of floral motifs.

The large floral collar displays six bands decorated with a variety of multi-coloured patterns, such as geometrical motifs (3rd, 5th, 6th bands), persea-tree buds (2nd band) and lotus flowers intertwined with cornflowers (1st band).³ The clasps of the collar are decorated with a falcon head and two lotus flowers.

On the chest, between the breasts and the hands, lies a pectoral featuring a ram-headed scarab (moulded) outstretching its wings and holding up a solar disk (moulded). The pectoral hangs from a necklace hidden under the short collar. The pectoral is flanked by coiled cobras with outstretched wings protecting *udjat*-eyes (centripetally oriented).

Central Panel

The central panel displays two registers (Fig. 97).

Some of the motifs of the composition are moulded in plaster to suggest relief, such as the scarab, the bodies of the enthroned gods, the *pet*-sign and the head and arms of the winged goddess. In many of these motifs the plaster collapsed.

The tableau is bounded by longitudinal inscriptions (Inscriptions 1–2), short transversal inscriptions (Inscriptions 4–5) and friezes.

The first register shows a symmetrical composition. The nuclear block features a ram-headed scarab holding up a solar disk flanked by cobras. The scarab rises from the *nebu*-sign flanked by cobras wearing the *atef*-crown (centrifugally oriented). The nuclear composition is flanked by centrifugal blocks featuring an enthroned mummiform Osiris protected by a winged goddess standing at his back. Osiris wears the *atef*-crown and grasps the royal scepters. The goddess is crowned with the modius and the name 'Neith' is inscribed over her head. Above these figures, one reads the following labels: *Lord of Abydos, great*

³ See Sousa 2018b, 97.

god that oversees the West, eye of Re', 'That they may give an invocation offering consisting of bread and beer' (right side) and 'That they may give the offering to Osiris, Lord of eternity, King of everlastingness' (left side).

The centripetal blocks feature a goddess squatting on a platform and outstretching her wings towards Osiris. The avian manifestation of the deceased rests on a divine standard under her wings, presenting offerings to the enthroned Osiris. Above this area one reads the following labels: 'I am Isis, the divine mother' (right side) and 'Nephthys, the divine sister, the eye of Re, the Mistress' (left side). Additional elements are displayed behind the squatting goddess: two mummiform gods stand on the *sema-tawy*, both wearing curled beards and identified as 'Hapy' and 'perfect god'.

The second register displays a large winged goddess squatted on a reed mat outstretching her wings towards both sides of the lid. The *pet*-sign figures above her, with three cobras pending from each side, protecting the inscription 'Nut, the great mother, who gave birth to all gods'. The goddess is flanked by a jackal (identified as 'Anubis') couched under her wings. The god holds up the *sekhem*-scepter in his forelegs. A standing goddess is depicted on the edge of the register, performing a ritual pouring. This goddess, clad in a tight beaded dress, is identified as 'Neith' (right side) or as 'Isis, the Mistress, the divine mother' (left side).

Lower Section

This section is arranged in three longitudinal partitions (Fig. 98). Two longitudinal bands of text run down the edges from the elbows to the footboard (Inscriptions 1–2).

The central partition presents four registers, each one decorated with a symmetrical composition. Elaborate friezes with geometrical and floral motifs divide the registers. Some of the features are moulded, such as the scarabs, squatted gods and sun disks.

The nuclear block of the first register is a scarab (black) holding up the solar disk (green) in its forelegs. It is flanked by centripetal blocks featuring a mummiform deity seated on a platform and grasping a feather. The god wears the *atef*-crown and has a curled beard.

In the second register the nuclear motif is the *sekhem*-scepter (moulded) standing on the *shen*-ring. It is crowned with the sun disk flanked by cobras. This motif is flanked by mourning goddesses squatted on *heb*-bowls. These goddesses are identified as 'Isis' by the monogram on their heads. Two *udjat*-eyes outstretch their wings above the goddesses.

In the third register the nuclear motif is a pectoral featuring a winged scarab (black) holding up the solar disk flanked by cobras. The pectoral hangs from

a necklace. Below, the *nebu*-sign is flanked by two coiled cobras (centrifugally oriented).

The fourth register (damaged) recalls the composition of the third one. The pectoral is here flanked by *udjat*-eyes on *neb*-signs.

The lateral partitions display four registers, divided by transversal bands partially inscribed (Inscriptions 4–12). Each scene depicts a divine shrine with the ceiling decorated with a double frieze composed of *iaret*-cobras and geometric patterns supported by columns. Inside each shrine a deity is depicted.

In the first register the deceased (*'The Osiris, scribe justified'*) stands under a vaulted pavilion wearing a white festive garment and an ointment cone on his head. He pours a libation (right side) and adores (left side) the mummiform *'Osiris, Lord of eternity, the great god'* seated on a throne that rests on a *heb*-bowl. The god has a curled divine beard, grasps the royal scepters and wears the *atef*-crown. The *imi-wt*-totem stands at his feet. The winged *udjat*-eye with two pending cobras figures above.

The second register recalls the composition of the first: the deceased, wearing the same garments pours ointments towards the avian form of *'Ptah-Sokar'*. The avian god, crowned with the composite *atef*-crown, rests on a sacred standard depicted in the form of the *sema-tawy*. At his feet a cobra rises wearing the *hedjet*-crown. Behind him figures the winged *udjat*-eye with a pending cobra.

The third register depicts the deceased as a standing mummiform god crowned with a modium. He wears a divine beard and is identified by the inscription *'The great god'*. This composition presents striking differences on each side: on the right partition, the enthroned deity is human-headed and wears the *atef*-crown and divine beard (the inscription says *'Ptah-Sokar'*), while on the left the god is falcon-headed, wears the *atef*-crown and holds the *was*-scepter (the inscription says *'Ptah-Sokar-Osiris, who dwells in the shrine'*).

The fourth register is preserved only on the left side and displays two mummiform deities squatted on a *heb*-bowl under a vaulted shrine supported by two *djed*-columns. The first deity is jackal-headed (Duamutef) and holds up the whip, while the second is falcon-headed (Qebhsenuf) and holds up the *hedjet*-mace. On the right side, a few remains of a squatting mummiform deity show that the subject of the vignette was the same, probably showing Hapy and Imseti.

Footboard

The footboard follows the same tripartite organization observed on the lower section (Fig. 99). The edges are inscribed (Inscriptions 1–2; Inscriptions 14–15), as well as the central partition, where three columns of text are found (Inscription 3).

The lateral partitions are decorated with reversed vignettes showing a mourning scene under a vaulted shrine. The mummiform Osiris stands on a platform, wearing the *atef*-crown and the *usekh*-collar. He grasps the *was* and *djed*-scepters. A mourning goddess is squatted on the *nebu*-sign. She is identified as 'Nephtys' by the inscription (but the monogram of Neith figures on her head on the left partition). She raises her right arm towards the head and leans the left one on the floor holding the *shen*-ring. Before her, figure three horizontal strokes writing the word 'water', perhaps alluding to the ritual mourning. A winged *udjat*-eye flies above the goddess (only on the left side).

The underside of the footboard displays a vaulted shrine below which stands a *djed*-pillar flanked by two poles of the West (Fig. 102).

Inscriptions

Two longitudinal inscriptions run down the edges from the elbows to the footboard (Inscriptions 1–2). The inscriptions are centripetally oriented. The hieroglyphs are outlined in red against a yellow background, with details painted in blue, green and red. Some of the hieroglyphs are finely executed, such as the *udjat*-eye in the beginning of the inscriptions (Gardiner D10), the *mwt*-vulture (Gardiner G15) and several vessels (Gardiner w1, w2, w15 and w21). The depiction of an ornamental *udjat*-eye at the beginning of both inscriptions is noteworthy. In the Inscription 1 the name of the first owner, Khonsumes, was not erased.

Inscription 1

dd mdw in Nt, wrt, mwt ntr; irt R^c, nbt pr-nfr, di.sn prt-hrw t, hnkt, k3w, 3pdw, sntr, kbh(w), irp, šs, mrht, ht-nb[t] nfr[t] w^cb[t], ht-nb[t] nfr[t] ndmt, nty n^h ntrw im.s, n Wsir sš n pr-Imn-R^c nsw ntrw [hⁿsw-ms --- m3^c-hrw]

Words to be spoken by Neith, the great one, the divine mother, the eye of Re, the eye [sic, intend is 'mistress'] of the House of Embalming. That they (sic)[read: she] may give an invocation-offering consisting of bread and beer, oxen and fowl, frankincense, libations, wine, alabaster and oil, everything good and pure, everything good and sweet on which the gods live, for the Osiris scribe of the Estate of Amun-Re, king of the gods, [Khonsumes, ---]justified.

Inscription 2

dd mdw in 3st, wrt, mwt ntr, irt Rc, hnwt Imntt, di.sn prt-hrw t, hnkt, k3w, 3pdw, sntr, kbh(w), šs mnht, mrht, irp, htp[w] df3w, [ht-nbt] nfr[t] w3b[t], ht-nb[t] nfr[t] ndmt, n[t]y 3nh ntr [t[m].s n Wsir] sš n pr-Imn-Rc nsw ntrw, hnsw-ms [m33-hrw]

Words to be spoken by Isis, the great one, the divine mother, the eye of Re, the mistress of the West. That they (sic)[read: she] may give an invocation offering consisting of bread and beer, oxen and fowl, frankincense, libations, clothing and alabaster, oil, wine, offerings and provisions, [everything] good and pure, everything good and sweet, [on which] the gods live, [for the Osiris], scribe of the Estate of Amun-Re, king of the gods, Khonsumes, [justified].

The central partition of the footboard is inscribed with three columns of text (Inscription 3). The hieroglyphs are outlined in red and painted in blue, green and red. The third column is badly damaged.

Inscription 3

(col. 1) *htp-di-nsw n Wsir, nb 3bdw, ntr 3, hnty Imntyw, Wnn-nfr [hk3] (col. 2) 3nhw, di.sn [sic, read: di.f] prt-hrw t, hnkt, k3w, 3pdw, sntr, kbh(w) [jrp] htp, df3w h[t]-nb[t] nfrt w3bt, ht-nbt nfrt] ndmt ---*

(col. 1) *An offering that the king gives to Osiris, Lord of Abydos, the great god, foremost of the Westerners, Unnefer, [ruler of] (col. 2) the living, so that they (sic) [read: he] may give an invocation offering consisting of bread and beer, oxen and fowl, frankincense, libations, [wine], (col. 3) offerings and provisions, everything [good and pure, everything good and] sweet, ---.*

Short transversal inscriptions divide the lower section in several registers (Inscriptions 4–13). The inscriptions are centripetally oriented and present variations of the same text. The first six bands are juxtaposed to the friezes of the shrines depicted in the corresponding vignette (Inscriptions 4–9). Inscriptions 14–15 act as label texts for the kneeling mourning goddesses painted on the footboard and, unlike the remaining inscriptions of the lid, are fully aligned with the inscriptions of the case. All the hieroglyphs are outlined in red against a yellow background, displaying some motifs painted in blue, green and red.

Inscriptions 4–5

im3hy hr Imsti

The venerable one before Imseti.

Inscriptions 6–7*imꜣhy ḥr ḥpy**The venerable one before Hapy.***Inscriptions 8–9***imꜣhy ḥr ḥpy**The venerable one before Hapy.***Inscription 10***[imꜣhy ḥr dwꜣ]-mwt[f], nꜥr ʿ3, sꜣ Wsir []**The venerable one before Duamutef, the great god, son of Osiris.***Inscription 11***imꜣhy ḥr dwꜣmwtf, nꜥr ʿ3, ---[nb?] dwꜣt{?}**The venerable one before Duamutef, the great god, son of Osiris, [Lord of the Duat***Inscription 12**

Lost

Inscription 13*[imꜣhy] ḥr Nbt-ḥwt, snt nꜥr, irt Rꜣ, ḥnwt Ímnt**[The venerable] one before Nephthys, the divine sister, the eye of Re, the mistress of the West.***Inscription 14***ink Nbt-ḥwt, snt nꜥr, irt Rꜣ, ḥnwt pr-nfr, dl.sn ḥt-nb[t] nfr[t] wꜣb[t], ḥt[-nbt] nfrt ndmt [---]**I am Nephthys, the divine sister, the eye of Re, the mistress of the House of Embalming, so that they [read: she] may give everything good and pure, [everything] good and sweet [---].*

Inscription 15

ink Nbt-ḥwt, snt ntr, irt R^c [ḥnwt] pr-nfr. di.sn ḥtp ḏfꜣw, [ḥt]-nb[t] nfr[t] wꜥb[t]

I am Nephthys, the divine sister, the eye of Re, the mistress of the House of Embalming. That they [read: she] may give offerings and provisions [and everything] good and pure.

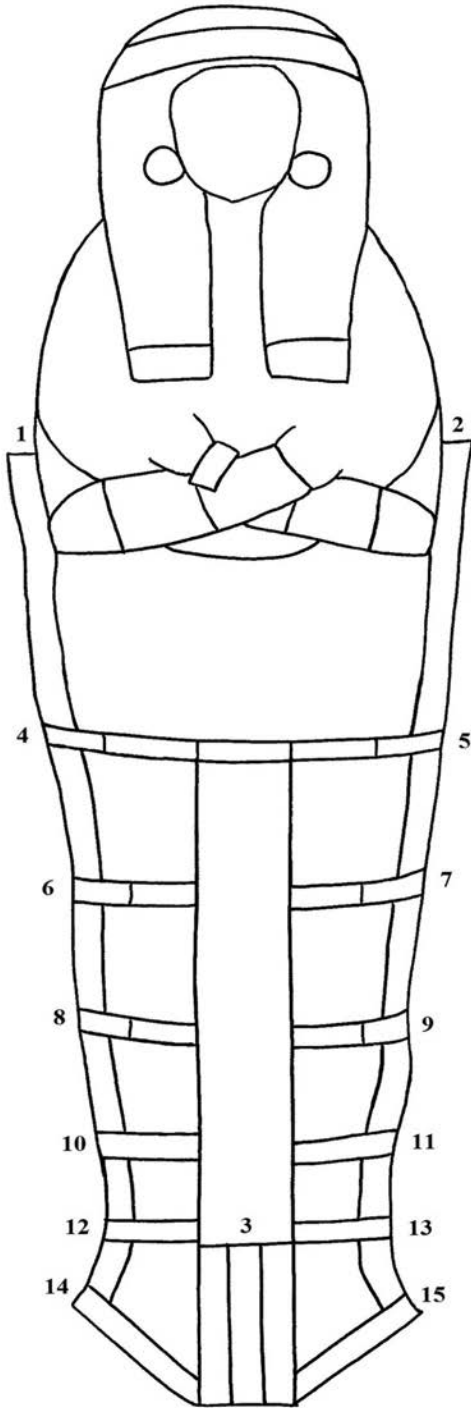
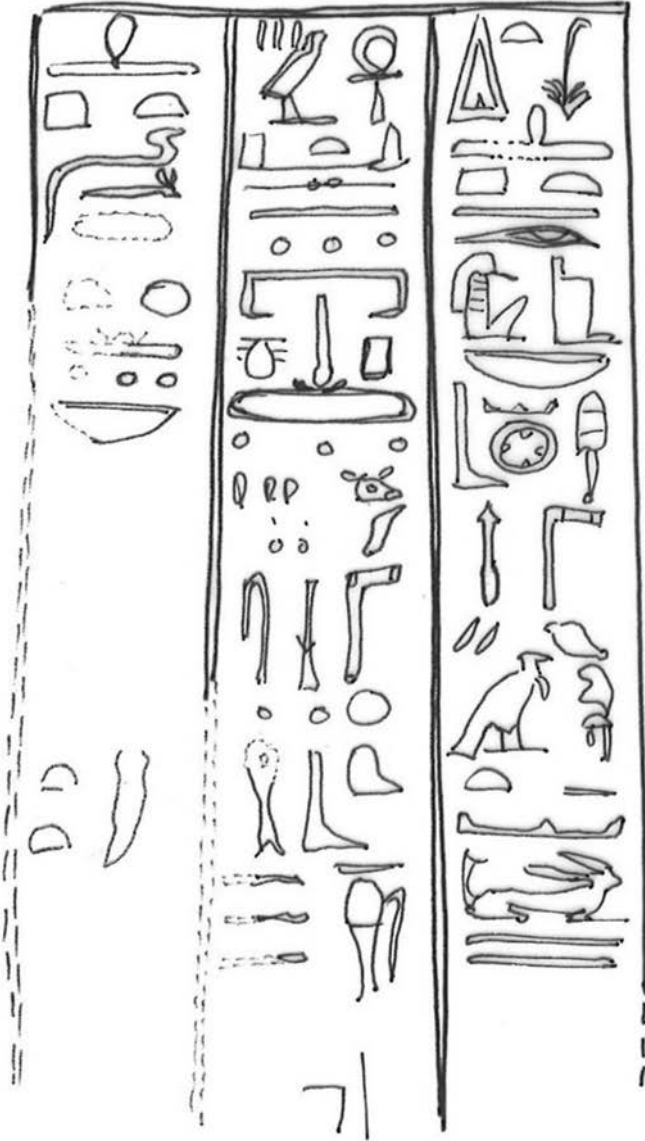
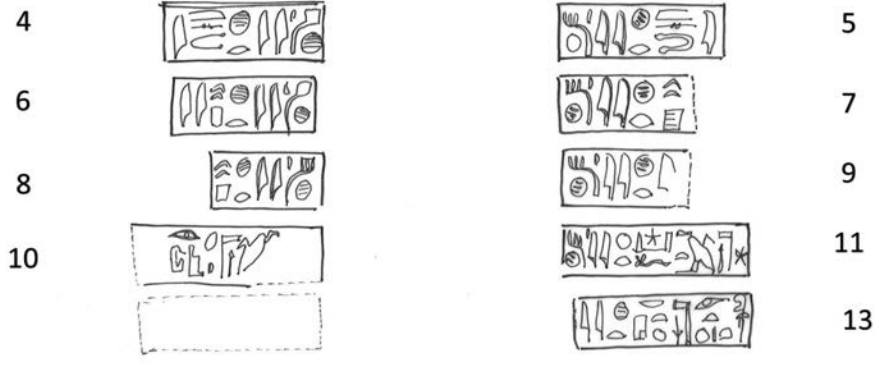

FIGURE 90
Lid (A.22). Inscriptions



3

FIGURE 92 Lid (A.22). Inscription 3



14



15

FIGURE 93 Lid (A.22). Inscriptions 4–11 and 13–15



FIGURE 94
Lid (A.22)



FIGURE 95 Lid (A.22). Headboard and upper section

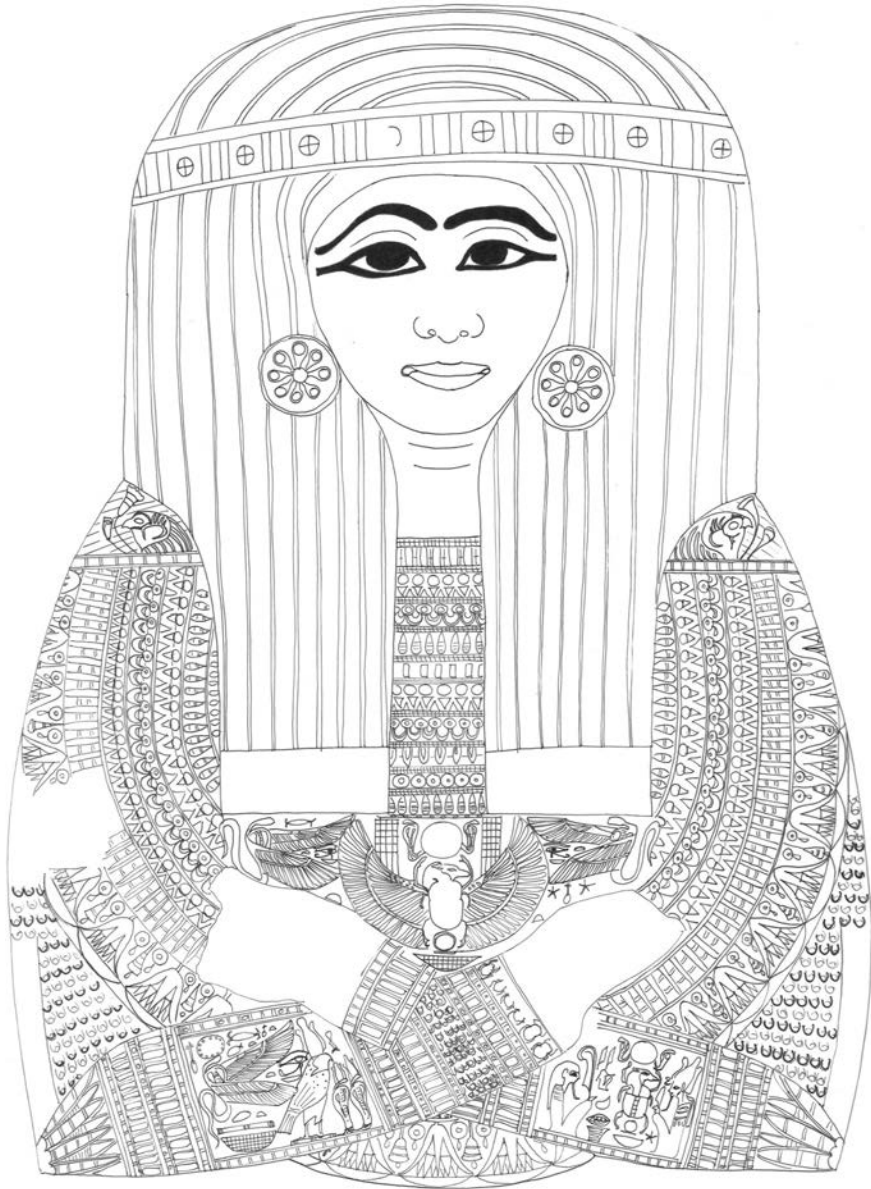

FIGURE 96 Lid (A.22). Headboard and upper section (drawing)



FIGURE 97 Lid (A.22). Central panel



FIGURE 98 Lid (A.22). Lower section



FIGURE 99 Lid (A.22). Footboard

10. Case

Museum inventory number: 8527

Length: 184 cm; Width (max): 48 cm; Depth: 31 cm

Wood, plaster, paint and varnish.

Decorated with multicoloured paintwork.

The interior remained undecorated.

The object shows several cracks along the joints. The decoration of the right side, particularly in the area next to the floorboard, is badly damaged.

Iconography (Exterior)

The upper edge is decorated with a frieze displaying alternating cobras (multicoloured) and feathers (green) facing the headboard. This frieze is bordered by black lines running parallel to a block-frieze. These motifs are discontinued on the headboard.

The vignettes are bounded by columns of hieroglyphic texts (Inscriptions 1–10) and a thick band (black) running along the wall. Some of the inscriptions are bounded by block-friezes (Inscription 1 and Inscription 6).

The lower edge shows traces of a thick monochromatic band (black).

Headboard

The headboard is composed of a tripartite panel (Fig. 102).

The *Vignette 1* (centre) shows a symmetrical composition with a large *tjet*-sign at the centre. It is adorned with red flowers, two at each side. Two poles of the West flank this motif, forming a centripetal composition.

The lateral panels do not display a figurative motif, but a striped pattern (black and yellow bands) recalling the decoration of the tripartite wig depicted on the lid.

Left Side

The upper section is decorated with two vignettes (*Vignettes 2–3*) forming a single scene depicting the god Thoth before the Osirian stepped mound (Fig. 104).

The *Vignette 2* depicts the ibis-headed god under a vaulted shrine holding the pole of the West (facing the footboard).

The *Vignette 3* is divided in two by the body of a great snake. In the upper part of the vignette, a mummiform deity seats on a throne, grasping the royal scepters. A winged goddess stands behind, outstretching her wings to protect

him. Behind the goddess is the figure of a mummiform deity wearing the modium and grasping four crossed spears. The *imi-wt*-totem stands at his feet. On the opposite side of the throne, stands another mummiform deity ('*Neith*'), wearing the modium. Offerings are displayed on a reed mat. The lower part of the vignette depicts a stepped mound. Inside this structure, the *sema*-sign figures at the centre, flanked by two cobras. On the right side of the staircase, the *ba*-bird carries the *nekhakha*-flail, raising his arms in adoration towards Thoth. On the opposite side of this stepped structure, the *udjat*-eye is depicted, together with the hieroglyphs *per-nefer*, an allusion to the '*House of Embalming*'.

The lower section of the left side is composed of a single vignette (*Vignette 4*) presenting four different scenes without a clear division between them (Fig. 105).

In the **first scene** the deceased ('*The Osiris, scribe justified*') faces the headboard presenting offerings to '*Osiris, the Lord*' seated on a throne depicted inside a shrine. The deceased has a short beard and wears a white festive garment, and an unguent cone. Osiris has a divine beard, wears the *atef*-crown and grasps the royal scepters. A goddess (labeled '*Isis*' in the inscription) stands behind the god wearing the monogram of *Neith* on her head. The *imi-wt*-totem stands at the feet of Osiris while the winged *udjat*-eye with a pending cobra figures above.

In the **second scene** a lion-headed goddess ('*Hereret, the mistress of the West*') stands inside a shrine entirely protected by *iaret*-cobras. She faces the headboard clad in a tight beaded dress holding a knife and the *was*-scepter in the left hand.

The **third scene** displays two registers. Three *Ma'at*-figures are depicted on each register, squatted on reed mats. Each one is crowned with a feather and grasps a large feather on her knees. Heading each register, a column of inscription states: '*Ma'at, the eye of Re*' (in the upper register the title '*Mistress of the West*' is added).

The **fourth scene** shows the sacred cow going forth from the Theban Mountain. The goddess stands on a reed mat, facing the headboard. She is adorned with the hathoric headdress and the sistrum. The body of the goddess is decorated with stars (blue). Before the deity, two columns of hieroglyphs bear the formula '*I am Hathor, mistress of the West, the eye of Re*' and a ritual vessel with lotus flowers figures on the mat. Below, a couched jackal is depicted, with the name '*Anubis*' written before him, and a winged *udjat*-eye depicted at his back. Behind the cow, a winged cobra outstretches its wings towards the goddess, embracing the *shen*-ring and the *udjat*-eye on a *neb*-sign, followed by the *ba*-

bird raising his arms in adoration. On the left edge, the tomb is depicted on the desert cliff, with the name 'Osiris' inscribed on its pyramidal superstructure.

Right Side

The upper section is decorated with two vignettes forming a single scene depicting the god Thoth before the cosmological scene of Geb and Nut (Fig. 107).

In the *Vignette 5* the ibis-headed god 'Thoth' holds the pole of the West under a vaulted ceiling.

At the centre of the *Vignette 6*, Shu (labeled 'Shu, the great god') faces the headboard, wearing his monogram on his head. He is flanked by *ba*-birds resting on reed mats with offerings at their feet. Shu holds up the bending body of 'Nut' on his upraised arms. The goddess wears bracelets (blue). Two poles of the West rise from her arms (left) and legs (right—a sacred falcon rests on this pole). The recumbent body of 'Geb' (his name is written below the *ba*-bird on the left side) is completely lost.

The lower section is composed of a single vignette (*Vignette 7*) displaying five scenes juxtaposed without formal divisions (Fig. 108).

In the **first scene** a little procession (facing the headboard) heads towards the enthroned Osiris. The deceased ('*The Osiris, scribe of the Estate [of Amun], justified*') is depicted with his arms crossed over the chest, in the position typically adopted in the court of law. He has a short beard and wears a white festive garment, and an unguent cone. He is preceded by an altar with offerings. Before him figures the ibis-headed 'Thoth, Lord of the divine words', grasping the scribal tablet. The god is preceded by the *imi-wt*-totem at his feet. Before Thoth stands the falcon-headed 'Horus', dark-skinned and crowned with the double-crown. Before the god is couched the Great Devourer, hippopotamus-headed, labeled as the '*Great of death*'. Horus raises his right arm towards the Osiris. The Osirian shrine is supported by two columns and its doors are open. Inside, Osiris is enthroned, wearing the *atef*-crown and the royal scepters. The *imi-wt*-totem stands at his feet. A goddess (identified as 'Mut' but with the monogram of 'Neith' on her head) stands at his back. The winged *udjat*-eye with a pending cobra wearing the *atef*-crown figures before his face.

The **second scene** depicts the winged scarab holding up the solar disk flanked by cobras. Two centrifugal coiled cobras figure under its wings. The scarab rises from the *sema-tau*i and it is depicted as a pectoral hanging from a necklace.

The **third scene** displays a centripetal composition featuring three mummiform gods standing on a coiled serpent. The central ram-headed mummiform

deity faces the headboard. He is flanked by a human-headed god (right) and a jackal-headed deity (left).

In the **fourth scene** the sacred falcon wearing the *atef*-crown rests on the pole of the West. Behind, figures the winged *udjat*-eye with a pending cobra.

The **fifth scene** probably depicted the *ba*-bird resting at the feet of the sycamore tree. The deceased raises his arms to drink the water poured out by the sycamore deity. The goddess stands among the leaves of the sacred tree, clad in a tight green dress and identified by the monogram of *Ma'at* on her head. Short labels refer to *Ma'at, the eye of Re*. On the right, the tomb is depicted, with the name *'Osiris'* inscribed on the pyramidal superstructure.

Footboard

The footboard displays a centripetal composition with a *djed*-pillar flanked by two poles of the West (Fig. 102).

Inscriptions

The texts are written on a yellow background. The hieroglyphs are outlined in red and coloured green, blue and red. These texts are written in columns bounded by vertical lines (black).

The left side displays 5 inscriptions (Inscriptions 1–5). Inscriptions 4 and 5 face the headboard, while Inscriptions 1, 2 and 3 face the footboard. The inscriptions are bordered by single (Inscription 4) or double block-friezes (Inscriptions 1 and 5), with exception of Inscriptions 2 and 3.

Inscription 1

ink 3st, wrt, mwt ntr, irt R, hnwt Imntt

I am Isis, the great one, the divine mother, the eye of Re, the mistress of the West.

Inscription 2

(col. 1) *dd mdw in dhwtw, nb mdw ntr, sš m3t* (col. 2) *n Psdt 3[t]: 'nh R, mt* (col. 3) *štyw, wd3 nty m db3t, nty m db3t, Wsir nb nhh'*

(col. 1) *Words to be spoken by Thoth, the lord of the divine words, scribe of Ma'at* (col. 2) *of the Great Ennead: 'Re lives, the turtle* (col. 3) *dies, uninjured is the one who is in the coffin/sarcophagus, who is in the grave[?], Osiris, the lord of eternity'.*

Inscription 3

dd mdw in dhwtj, nb mdw-ntr, sš m3t n

Words to be spoken by Thoth, lord of the divine words, scribe of Ma'at of (...)

Inscription 4

(col. 1) *dd mdw in Wsir nb nhh, hk3 nhw ntr 3* (col. 2) *hnty Imntyw, di.sn šs mnht, [mrht]*

(col. 1) *Words to be spoken by Osiris, lord of eternity, ruler of the living the great god* (col. 2), *the foremost of the Westerners. That they [read: he] may give clothing, alabaster and ointment.*

Inscription 5

(col. 1) *dd mdw in 3st, wrt, mwt [ntr]* (col. 2) *irt R, hnwt pr-nh [di.sn df3w(?)---]*
(col. 3) *ht-nb[t] nfr[t] w3b[t], ht[-nbt nfrt ndmt ---]*

(col. 1) *Words to be spoken by Isis, the great one, the [divine] mother,* (col. 2) *the eye of Re, the mistress of the House of Life. [That they [read: she] may give ---]*
(col. 3) *[provisions], everything good and pure, everything [good and sweet ---].*

The right side displays 5 inscriptions (Inscriptions 6–10). Inscriptions 6, 9 and 10 face the headboard, while Inscriptions 7 and 8 face the footboard. The inscriptions are bordered by a single (Inscriptions 7 and 9) or a double block-frieze (Inscriptions 6 and 10), with exception of Inscription 8.

Inscription 6

dd mdw in 3st, wrt, mwt ntr, irt R

Words to be spoken by Isis, the great one, the divine mother, the eye of Re.

Inscription 7

(col. 1) *dd mdw in dhwtj, nb mdw-ntr, sš [m3t]* (col. 2) *n Psdt 3[t]: 'nh R, mt štyw'*

(col. 1) *Words to be spoken by Thoth, lord of the divine words, the scribe of Ma'at*
(col. 2) *of the Great Ennead: 'Re lives, may the turtle dies'.*

Inscription 8

dd mdw in dḥwty, nb mdw-ntr, sš m3[·t]

Words to be spoken by Thoth, lord of the divine words, the scribe of Ma'at.

Inscription 9

(col. 1) *dd mdw in Wsir, nb nḥḥ, ḥk3 d[t]*

Words to be spoken by Osiris, lord of eternity, ruler of everlasting[ness].

Inscription 10

(col. 1) *dd mdw in 3st, wrt, [mwt ntr]* (col. 2) *irt R3, ḥnwt pr[-nfr--- di.sn ---]* (col. 3) *df3w, ḥt-[nbt nfrt w3bt, ḥt-nbt nfrt ndmt]*

(col. 1) *Words to be spoken by Isis, the great one, [the divine mother]* (col. 2) *[the eye] of Re, the mistress of the House of [Embalming. That they [read: she] may give]* (col. 3) *provisions, [every]thing [good and neat, everything good and sweet].*

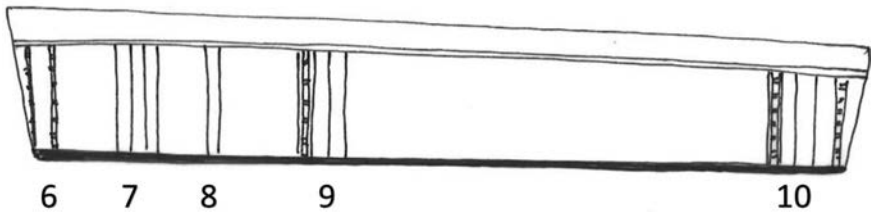
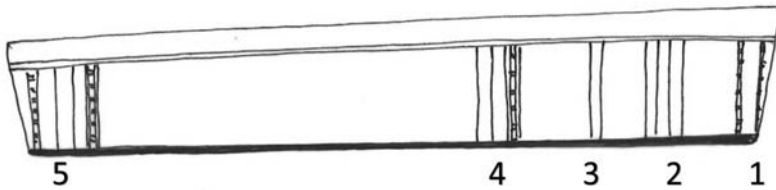

FIGURE 100 Case (A.22). Inscriptions

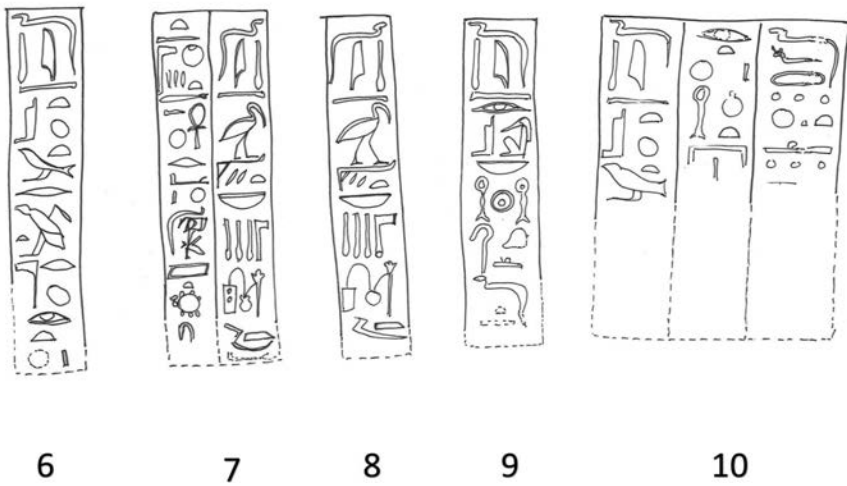
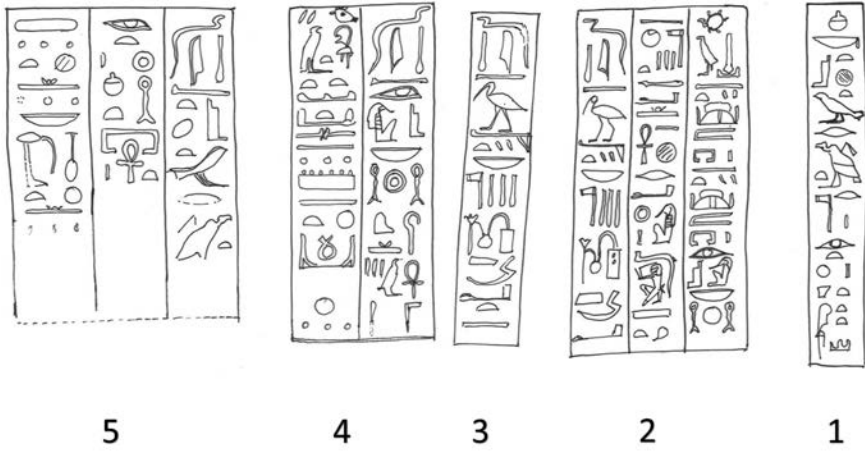

FIGURE 101 Case (A.22). Inscriptions 1-10



FIGURE 102
Case (A.22). Headboard
(above), footboard
(below)



FIGURE 103
Case (A.22). Left side



FIGURE 104 Case (A.22). Left side, upper section



FIGURE 105 Case (A.22). Left side, lower section



FIGURE 106
Case (A.22). Right side



FIGURE 107 Case (A.22). Right side, upper section



FIGURE 108 Case (A.22). Right side, lower section

11. Mummy-Cover

Museum inventory number: 9530

Length: 182 cm; Width (max): 39 cm

Wood, plaster, paint and varnish.

Decorated with multicoloured paintwork.

The reverse side of the object is undecorated.

The lappets are moulded in plaster. The original fists were removed and open hands crudely carved in wood were attached to the object.

Preserved in relatively good condition. The object is fragmented on the right side of the upper section and on the central panel. The lower edge is lost.

Iconography

Headboard

The 'crown of justification' adorns the tripartite wig decorated with a striped pattern (yellow bands against black background) and terminals (yellow). The face is well carved and painted in yellow. The eyes and eyebrows are outlined in black. The pupils (black) are painted against a white background. A red line is traced above the eye to suggest the eye-lid. The lips and the nostrils are outlined in red.

The earrings are painted, not moulded (Fig. 112).

Upper Section

The hands (yellow) are open and crudely attached to the chest (Fig. 112).

The arms are decorated with a feathered motif and the elbows are decorated with lotus flowers (multicoloured). As on the lid, the forearms display several bracelets. Some have geometrical motifs (multicoloured), while others feature the avian form of Ptah-Sokar wearing the sun disk. The avian god is preceded by a cobra wearing the *atef*-crown. The winged *udjat*-eye with a pending cobra figures at his back. A column of hieroglyphs identifies the god (*'Ptah-Sok(ary)'* on the right side, *'Ptah'* on the left side).

The area comprised between the lappets of the wig presents a short collar decorated with eight bands of floral motifs.

The large floral collar displays four bands decorated with different patterns: mandrake flowers (4th band), geometrical motifs (3rd band), perseae-tree buds (2nd band), lotus flowers intertwined with cornflowers (1st band). The clasps of the collar are decorated with a falcon head and lotus flowers.

On the chest lies a pectoral featuring a winged ram-headed scarab holding up a solar disk. The pectoral hangs from a necklace hidden under the short collar. The pectoral is flanked by two winged cobras (centripetally oriented), identified as *'Neith'*.

Central Panel

The central panel displays two registers (Fig. 113).

The first register shows a symmetrical composition with a pectoral at the centre featuring a ram-headed winged scarab (black) holding up a solar disk. The pectoral hangs from a necklace hidden under the large floral collar. The sacred scarab rises from the *nebu*-sign flanked by two cobras (centrifugally oriented). The nuclear composition is flanked by centrifugal blocks featuring the avian form of Ptah-Sokar resting on a *heb*-bowl. The avian god, identified by the inscriptions above his head, wears the *atef*-crown and is preceded by a cobra at his feet.¹ The composition involves centripetal blocks featuring a winged coiled cobra resting on a platform. The goddess wears the monogram of Neith on her head and the *was*-scepter is featured at her side. Between her wings figure the *shen*-ring and the *udjat*-eye resting on a *neb*-sign.

The second register displays a large winged goddess squatted on a reed mat outstretching her wings towards the sides. The *pet*-sign figures above her. Inscriptions and decorative hieroglyphs are displayed along the arms of the goddess, such as the epithets *'Nut, the great one, who gave birth to the gods'*, and the *nefer*-sign flanked by *udjat*-eyes. Under her wings figures a coiled cobra.

Lower Section

This area is divided into two longitudinal partitions by a double column of hieroglyphs (Inscriptions 1–2). Both partitions display four registers, each one depicting a shrine supported by *djed*-columns (Fig. 114). In the three upper registers, the shrine is decorated with a frieze of multicoloured *iaret*-cobras with solar disks. The fourth register only displays a vaulted ceiling.

The edges are decorated with longitudinal block-friezes.

In the first register an enthroned mummiform god (identified as *'Osiris'*) wears the *atef*-crown and holds the *was*-scepter and the *nekhakha*-flail. A mummiform deity stands before the throne wearing the divine beard and a

1 On the left side the name *'Ptah-Sokar'* is written in three columns centrifugally oriented, with the last two signs of the name inverted. On the right side, the name *'Ptah-Sokar'* is written in two columns centripetally oriented, while the title *'the great god, the lord of the land'* is depicted in two columns centrifugally oriented.

modium (left side) or the monogram of Neith (right side) on his head. The composition rests over a large *heb*-bowl.

The second register depicts the avian form of Ptah-Sokar resting on a platform with a cobra at his feet. The avian god wears the *atef*-crown and he is identified as '*Ptah-Sokar*' by the inscription at his back. The winged *udjat*-eye with a pending cobra figures behind him.

In the third register two standing mummiform deities face outwards. On the right side, the first god is ram-headed and the second is human-headed, both wearing beards (the inscription refers to the '*great god, the foremost*'). On the left side the first god is lion-headed, while the second is human-headed with divine beard.

The fourth register is lost but vestiges of a vaulted shrine are detected.

Inscriptions

Two longitudinal inscriptions (Inscriptions 1–2) run down the centre of the lower section. The inscriptions are centripetally oriented. The quality of the writing is good (cf. Inscriptions 1–2 on the lid). The hieroglyphs are outlined in red against a yellow background, with motifs painted in blue, green and red. Some of the hieroglyphs are finely executed and multicoloured such as the *mwt*-vulture (Gardiner G15) and the determinative in the name of the god Wennefer (Gardiner A42 with the *heqa*-scepter). The name of the first owner, Khonsumes, was erased in both inscriptions and the name and titles of the female usurper were written over it. However, since the lower edge is broken, we can read only the title '*Osiris, mistress of the house*' while the name is lost.

Inscription 1

ḥtp-dī-nsw n Wsir nb ʒbdw, ntr ʕ, ḥnty ʔmntyw, Wnn-nfr, ḥkʕ nḥw, dī.sn prt-ḥrw t, ḥnkt, kʕw, ʒpdw, sntr, kbḥ(w), irp, šs, mnḥt, n Wsir nbt-pr [---]

An offering that the king gives to Osiris, lord of Abydos, the great god, the foremost of the Westerners, Unnefer, the ruler of the living, so that they (sic)[read: he] may give an invocation offering consisting of bread and beer, oxen and fowl, frankincense, libations, wine, clothing and alabaster, for the Osiris mistress of the house [---].

Inscription 2

ḥtp dī nsw n ʕst, wrt, mwt ntr, irt R, ḥnwt pr-ḥ, dī.sn ḥtp dfʕw, mrḥt, ḥt-nb[t] nfr[t] wʕb[t], ḥt-nb[t] nfrt ndmt, nty ḥḥ ntrw imy s, n Wsir nb.t pr [---]

An offering that the king gives to Isis, the great one, the divine mother, the eye of Re, the mistress of the House of Life, so that they (sic) [read: she] may give offerings and provisions, oil, everything good and pure, everything good and sweet, on which the gods live, for the Osiris mistress of the house [---].

Short transversal inscriptions (Inscriptions 3–4) bordered the third and the fourth registers of the lower section. The texts are centripetally oriented and the hieroglyphs are outlined in red and painted in blue, green and red.

Inscription 3

imꜣḥy ḥr [---]

The venerable one before [---].

Inscription 4

imꜣḥy ḥr dwꜣmwtf

The venerable one before Dua[mutef].

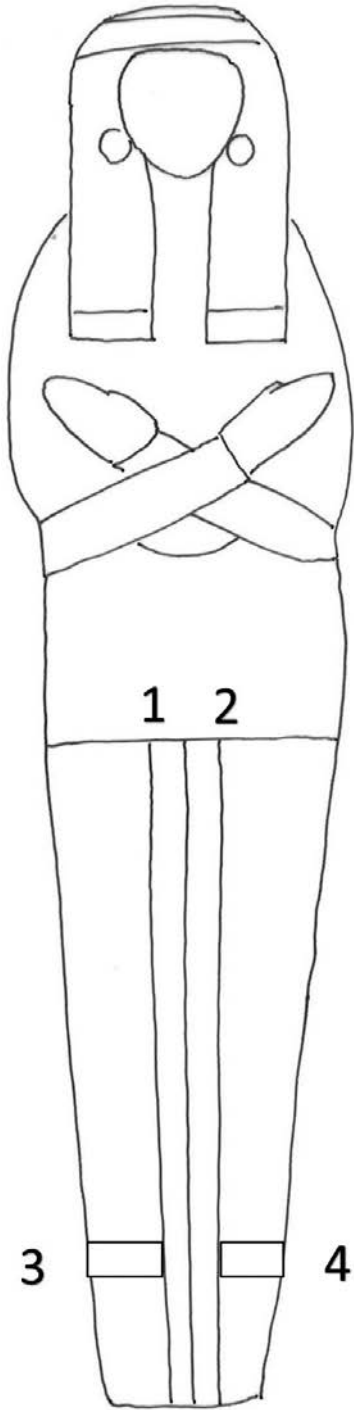

FIGURE 109
Mummy-cover (A.22). Inscriptions



FIGURE 111
Mummy-cover (A.22)



FIGURE 112 Mummy-cover (A.22). Headboard and upper section



FIGURE 113 Mummy-cover (A.22). Central panel



FIGURE 114
Mummy-cover
(A.22). Lower
section

Outer Coffin of an Anonymous Man (A.56)

Summary description: Outer anthropoid coffin (12–13), anonymous.

Archaeological context and dating: The coffin was found in the main gallery of Bab el-Gasus, next to the western wall. The scheme of decoration suggests the late 21st Dynasty. Daressy did not provide records about this burial assemblage.¹

Name and titles of the owner: A blank space was left to be inscribed with the name of the owner. This procedure is detected on the lid (Inscriptions 6–7) and on the case (Inscriptions 1–2). However the texts present generic titles such as “*Wab priest of Amun*” and “*Scribe*”. Apparently, the name Karo was found during the examination of the mummy.²

¹ Aston 2009, 173 TG 729.

² This name is quoted by Daressy in his second report (1907, 19) but no explanation is provided on its provenance. A shabti for a man named “Karo” is preserved in the Egyptian Museum in Riga (K 1263). See Berlev and Hodjash 1998, 93 n. 69 (pl. 117). See, in this volume, the chapter by Marianna Zarli on the reconstruction of the coffin ensembles.



FIGURE 115 Outer coffin (A.56)

12. Lid

Museum inventory number: 8525

Length: 212 cm; Width (max): 70 cm

Wood, plaster, paint, varnish.

Decorated with multicoloured paintwork and occasional use of moulded plaster.

The ears are moulded. The beard and the hands are carved in wood and attached to the lid.

The reverse side of the object is undecorated, as well as the underside of the footboard.

The left side is badly damaged, mainly on the headboard. The paint has collapsed on the wig, on the large floral collar and on the footboard.

The object was restored in the workshops of Florence Museum during the years 1957–1958.¹

Iconography

Headboard

The tripartite wig is striped (yellow bands on a black background). A bunch of three lotus flowers hangs over the forehead. The skin is yellow and the contour of the eyes and eyebrows is traced in black. The pupils (black) are painted against a white background. The lips are outlined in red (Figs. 121–122).

The ears are moulded over the wig. The beard is painted black on the sides of the cheeks, while the long goatee is carved in wood and attached to the chin by a pin. This is painted black with a braiding motif outlined in yellow. The lappets of the wig are adorned with terminals (yellow).

Upper Section

The fists are painted yellow and crossed over the chest (Figs. 121–122). The forearms are hidden under the floral collar. The floral collar is remarkably large, extending from the neck to the abdomen. It displays up to 22 bands, but the variety of floral patterns used is surprisingly poor, showing only four different motifs: checkered motifs (2nd, 4th, 6th, 8th, 10th, 12th, 14th, 16th, 18th, 20th bands), lotus petals (5th, 7th, 9th, 11th, 15th, 19th bands), lotus petals and

¹ Bosticco 1958, 10.

persea-tree buds (3rd, 13th, 17th bands), lotus flowers and perseas-tree flowers (1st band). Small lotus flowers cover the elbows.

Central Panel

The central panel displays three registers (Fig. 123). Most of the motifs are moulded in plaster to suggest relief, especially along the longitudinal axis of the composition, such as the scarabs, the bodies of the enthroned gods, the *hwt*-thrones, the solar disks, the *tjet*-signs, the *imi-wt*-totems, the hair and the body of the winged goddess. The edges of the tableau are bounded by longitudinal inscriptions (Inscriptions 3–4) and transversal block-friezes.

The first register shows a symmetrical composition. The nuclear block features a scarab holding up a solar disk (red). On each side of the scarab, a *tjet*-sign stands on a *neb*-sign. This composition is flanked by centrifugal blocks featuring an enthroned mummiform Osiris wearing the *hedjet*-crown. The *imi-wt*-totem stands at his feet. Centripetal blocks complete the composition featuring a squatted winged goddess. She outstretches her wings towards Osiris. The deceased is depicted under her wings as a kneeling mummiform god together with the *udjat*-eye. An enthroned god is featured above her wings.

In the second register figures a squatted winged goddess outstretching her wings towards both sides of the lid. She wears a solar disk (green) and a long tight dress (red). Liminal elements are symmetrically displayed above the wings of the goddess forming an alternate sequence of squatting deities, vultures, falcons, cobras and *shetyt*-shrines.

The third register recalls the composition of the first register. The nuclear block features a sacred scarab holding up a solar disk. Here the scarab rises from the *nebu*-sign, flanked by frogs. Large *tjet*-signs flank the scarab. The nuclear composition is flanked by the enthroned Osiris grasping the royal scepters and wearing the *hedjet*-crown. The *imi-wt*-totem stands at his feet. The title '*Osiris, the Lord*' is written over his head. The centripetal blocks feature a squatted winged goddess outstretching her wings towards Osiris, embracing the deceased (depicted as a kneeling mummiform god), the *udjat*-eye, and a sacred cobra. A squatted jackal-headed god and the *udjat*-eye are depicted above her wings.

Along the edges of the composition, additional blocks form four autonomous registers. From top to bottom one detects the *Ta-wer*-totem standing on the *nebu*-sign, decorated with a double-feathered solar headdress. Next to the totem figures a sacred cobra, a squatted mummiform god and the *imi-wt*-totem. In the second register figures a mummiform god squatting on a reed mat. The third register displays an enthroned mummiform Osiris grasping the royal scepters and wearing the *hedjet*-crown. A sacred cobra, the *imi-wt*-totem fig-

ure at his feet. The fourth register is badly damaged on both sides, but a sacred cobra resting on a reed mat can be detected.

Loose hieroglyphs are found between the interstitial areas of the compositions. An abundant use was made of liminal elements which are depicted all around the main figures.²

Lower Section

This section is arranged in three longitudinal partitions (Fig. 124). Two longitudinal bands of text run down the edges from the elbows to the footboard (Inscriptions 3–4). Most of the motifs of the central partition are moulded in plaster to suggest relief, such as the *tjet*-knot, solar disks, mummiform gods, scarabs and mats.

The central partition is flanked by two longitudinal columns of text (Inscriptions 1–2) bounded by block-friezes. It displays three registers, each one decorated with a symmetrical centripetal composition. Elaborate friezes with geometrical and floral motifs divide the registers.

In the first register the *tjet*-knot (black) is crowned with a solar disk (green) flanked by pending cobras. The centripetal blocks feature a mummiform deity wearing a solar disk. He is squatted on a mat and the *nebu*-sign.

The second register displays the sacred scarab (black) holding up a solar disk. These motifs are flanked by squatted mummiform gods wearing a solar disk. They grasp *was*-scepters.

The third register recalls the composition of the first one, with a central *tjet*-knot (black) crowned with a solar disk (green) flanked by pending cobras. This motif is flanked by mummiform gods (moulded) wearing sun disks (red) and squatted on *nebu*-signs.

The lateral partitions display three registers bounded by transversal block-friezes. Each scene depicts the deceased wearing tight garments and the *usekh*-collar. He stands before an enthroned Osiris with the *imi-wt*-totem at his feet. Osiris wears the *hedjet*-crown. A winged deity is depicted behind the god. In the first register this winged deity is featured as a large solar falcon resting on the *nebu*-sign. The label *Lord of the burial* is found on the upper part of the vignette. In the second register, this deity is depicted as a standing goddess. She wears a tight beaded dress and wears the solar disk (green). The labels *Isis* and *Osiris, lord of the burial* are found on the upper part of the vignette.

In the third register, a winged cobra is featured, with the solar disk (red). The labels *Osiris* and *Neith* are found above.

² For parallels see the outer coffin n. 8524 (from A.15).

Footboard

The footboard follows the same tripartite organization observed on the lower section (Fig. 125). The edges of the footboard are bounded by inscriptions (Inscriptions 3–4) and a block-frieze. The central partition is inscribed with three inscriptions (Inscriptions 5–7) bordered by Inscription 1 and Inscription 2.

The layout of the lateral partitions presents two registers. The first register is badly damaged on both sides, but an offering scene can be detected. The deceased makes an offering before an enthroned mummiform god.

The second register displays a reversed vignette. The decoration on the left side collapsed, but on the right side a standing god wearing a long garment (black) adorned with braces (red) can be detected. The scene recalls the royal Heb Sed festival. The god grasps a long mace. The *imi-wt*-totem stands at his feet and an offering table is depicted before him. On the left side, a small mummiform figure squatted before the *imi-wt*-totem can be detected.

Inscriptions

Two longitudinal inscriptions (Inscriptions 3–4) are written along the edges of the lid. Inscriptions 1 and 2 divide the lower section of the lid into three partitions. The hieroglyphs are outlined in red and painted in blue, green and red. Some of the hieroglyphs used in these inscriptions are sophisticated, such as the upright mummy (Gardiner A53), the sacred falcon (Gardiner G5), the *mwt*-vulture (Gardiner G15), the crested ibis (Gardiner G25), the fatted duck (Gardiner G42), the sacred barque (Gardiner P1) and the Osiris seat (Gardiner Q2). The inscriptions are centripetally oriented.

Inscription 1

jmšhy hr Wsir, nb nhh, hnty ĩmntt, ntr ʿs, nb ʾbdw, dī.sn htpw, dfʾw, ht-[nbt] nfrt wʾb[t], ht-nb[t] nfr[t] ndm[t], hʾ m kʾw, hʾ m ʾpdw, hʾ m šš, mnht [n] sʾh [] wʾb

The venerable one before Osiris, the lord of eternity, the foremost of the West, the great god, lord of Abydos. That they (sic) [read: he] may give offerings and provisions, everything good and pure, everything good and sweet, a thousand of oxen, a thousand of fowl, a thousand of alabaster and clothing to the noble one, the wab-priest.

Inscription 2

*jmꜣꜥhy hr Rꜥ-hr-ꜣꜥty-tm, nb tꜣwy, Íwnwy, ntr ꜣ, hꜥ m wꜣs, s.hꜥ.f tꜣwy [m] ꜣꜥty[.f], nb
iꜣwt [---] st [---] htpw dfꜣw, hꜣ m kꜣw, hꜣ m ꜣpdw, hꜣ m [---]*

The venerable one before Re-Horakhty-Atum, the lord of the Two Lands [and] of Heliopolis, the great god who appears in the barque, while he enlightens the Two Lands with his eyes, the lord of the sacred mounds [---] place [---] offerings and provisions, a thousand of oxen, a thousand of fowl, a thousand of [---].

Inscription 3

*imꜣꜥhy h[r] [--- hꜣ m] kꜣw, hꜣ m ꜣpdw, hꜣ m ht-nb[t] nfr[t] wꜥb[t] [n?], hꜣ m ht-nb[t]
nfr[t] ndm[t], hꜣ m šs, mnht.*

*ink ꜣst, mwt ntr, irt Rꜥ, hrnw.t [] di.s htpw, dfꜣw, hꜣ m kꜣw, ꜣpdw, hꜣ m šs mnht [n]
Wsir wꜥb n Ímn, sš n [pr-Ímn]*

The venerable one before [--- a thousand of] oxen, a thousand of fowl, a thousand of all things good and pure, a thousand of all things good and sweet, a thousand of alabaster and clothing.

I am Isis, the divine mother, the eye [of Re, the mistress of], so that she may give offerings and provisions, a thousand of oxen and fowl, a thousand of alabaster [vessels] and clothing [for] the Osiris, the wab-priest of Amun and Scribe of [the Temple of Amun].

Inscription 4

*imꜣꜥhy hr ꜣst, mwt ntr, wr[t] sh-ntr. di.s htpw dfꜣw, ht-nb[t] nfr[t] wꜥb[t], ht-nb[t]
nfr[t] ndm[t], hꜣ m kꜣw ꜣpdw, [šs, mnht] [n] Wsir, imꜣꜥhy hr ꜣst, mwt ntr, irt [Rꜥ] di.s
hꜣ m kꜣw ꜣpdw, htpw, ht-nb[t] nfr[t] wꜥb[t] n Wsir wꜥb n [pr-Ímn], sš*

The venerable one before Isis, the divine mother, the great one of the divine shrine, may she give offerings and provisions, everything good and pure, everything good and sweet, a thousand of oxen and fowl, [a thousand of alabaster [vessels] and clothing] [for] the Osiris, the venerable one before Isis, the divine mother, the eye [of Re] that she may give a thousand of oxen and fowl, offerings and everything good and pure for the Osiris, the wab-priest and scribe.

The central partition of the footboard is inscribed with three columns of text (Inscriptions 5–7). The spaces reserved for the name of the deceased were left blank.

Inscription 5

ihhy n R^c-hr-ꜥhty-tm, nb tꜥwy, Íwnwy, ntr ꜥꜥ, hr m wꜥꜥ, s.hꜥ.f tꜥwy[m] ꜥh[ty:f],

Rejoicing to Re-Horakhty-Atum, lord of the Two Lands, and of Heliopolis, the great god who appears in the barque, while he enlightens the Two Lands with [his] eyes.

Inscription 6

ꜥi[.f] htpw ꜥfꜥw, ht-nb[t] nfr[t] wꜥb[t] n Wsir wꜥb n Ímn [Space left blank for the name]

May he give offerings and provisions, everything good and pure to the Osiris, the wab-priest of Amun [Space left blank for the name].

Inscription 7

ꜥi[.f] htpw ꜥfꜥw, ht-nb[t] nfr[t] [n] Wsir wꜥb n Ímn [Space left blank for the name]

May he give offerings and provisions, everything good [to] the Osiris, the wab-priest of Amun [Space left blank for the name].

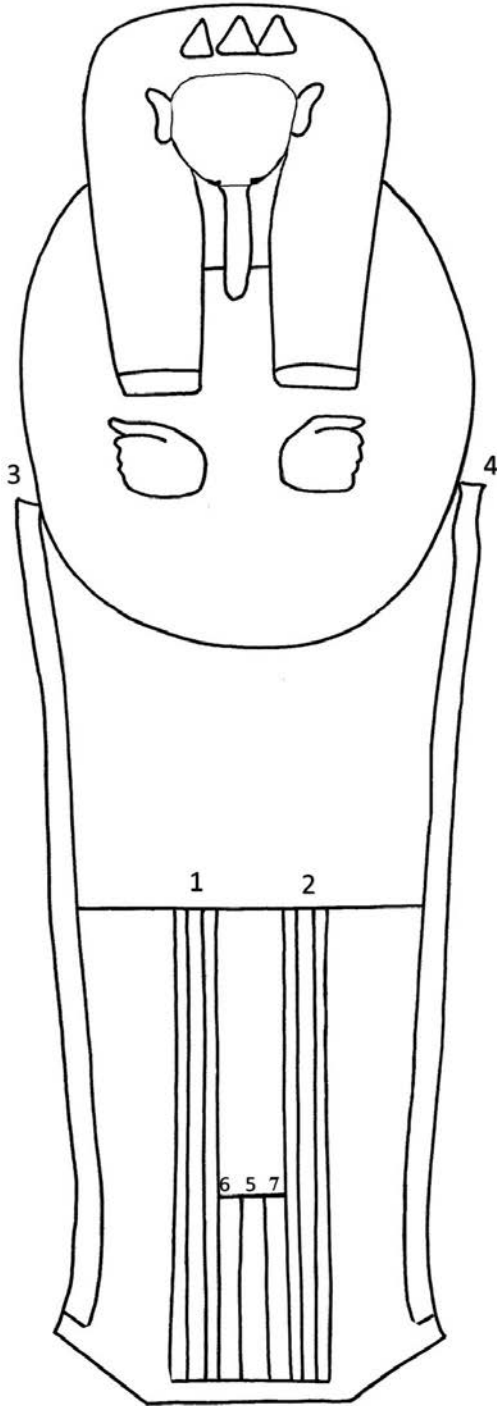

FIGURE 116
Lid (A.56). Inscriptions

1

2

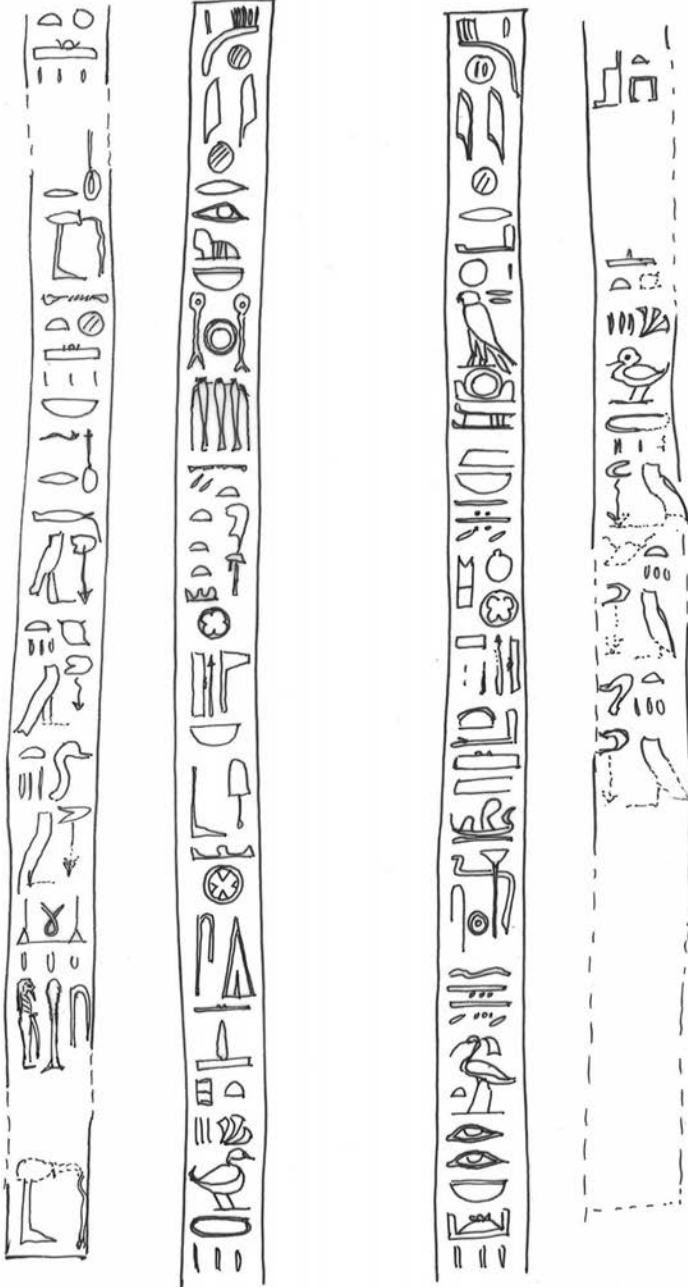

FIGURE 117
Lid (A.56).
Inscriptions
1-2

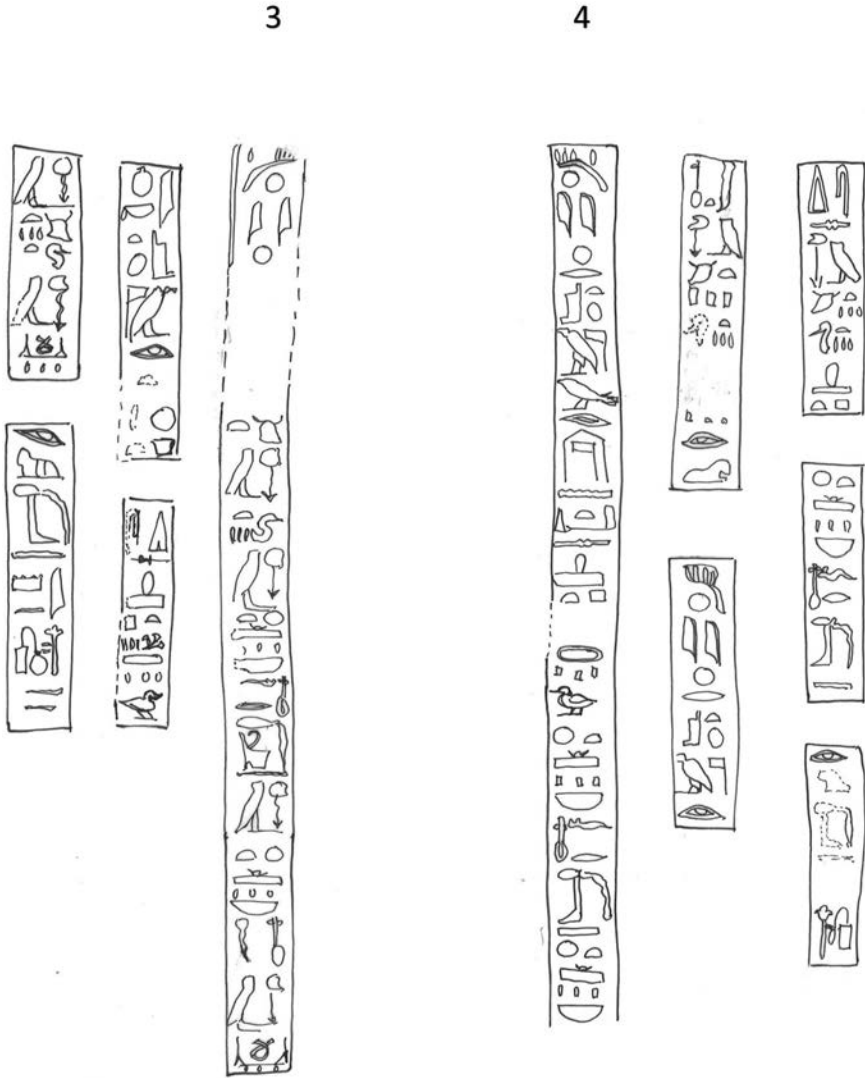

FIGURE 118 Lid (A.56). Inscriptions 3-4

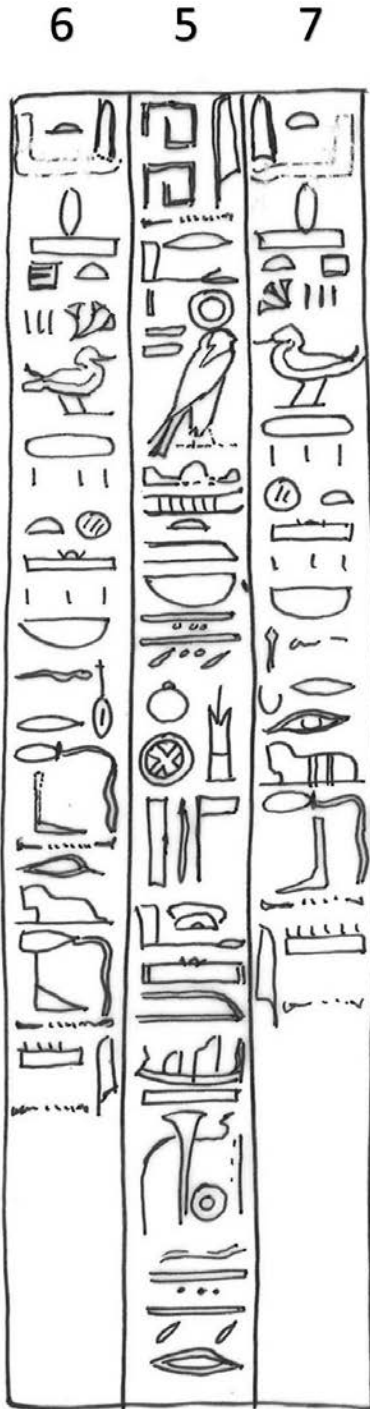

FIGURE 119
Lid (A.56). Inscriptions 5-7



FIGURE 120
Lid (A.56)



FIGURE 121 Lid (A.56). Headboard and upper section

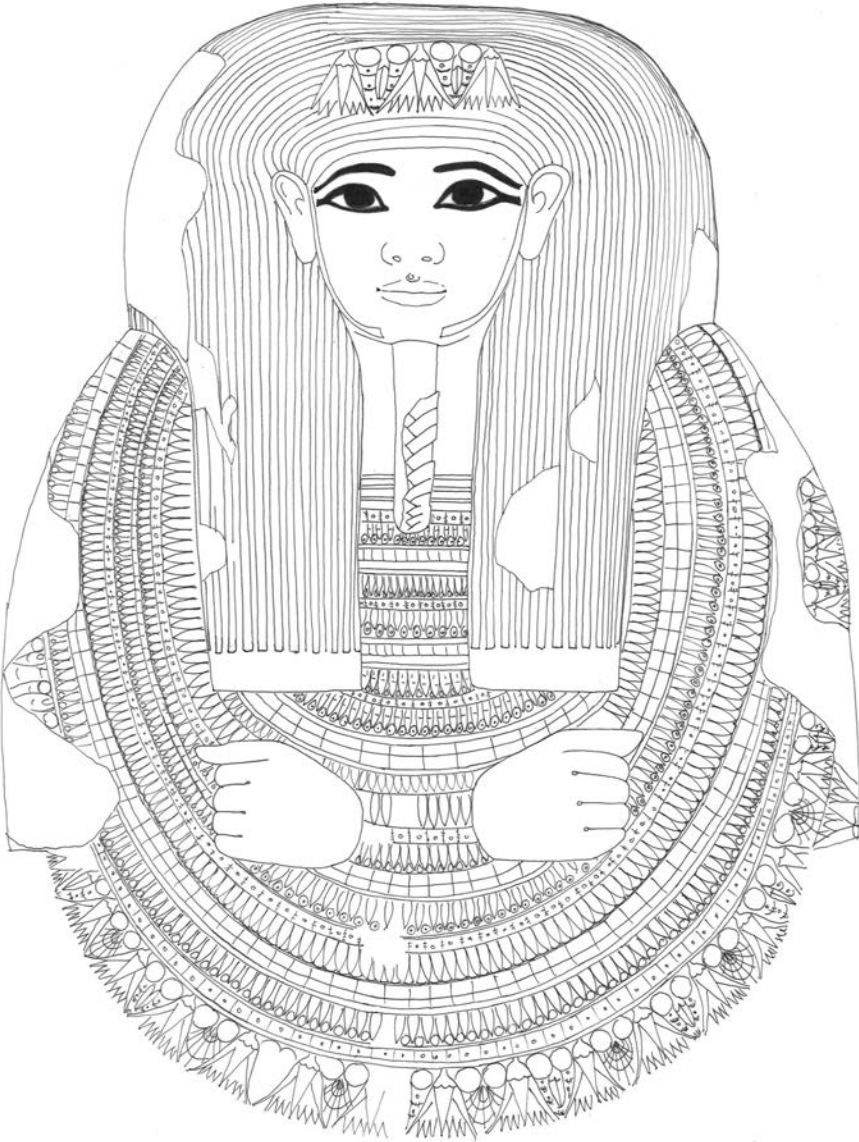

FIGURE 122 Lid (A.56). Headboard and upper section (drawing)



FIGURE 123 Lid (A.56). Central panel



FIGURE 124 Lid (A.56). Lower section



FIGURE 125 Lid (A.56). Footboard

13. Case

Museum inventory number: 8525

Length: 212 cm; Width (max): 70 cm; Depth: 46 cm

Wood, plaster, paint and varnish.

Decorated with multicoloured paintwork.

The exterior wall of the footboard remained undecorated.

The object shows several cracks along the whole surface. The exterior decoration of the side walls is badly damaged, especially on the upper section: on the right side the paint collapsed while on the left side a loss of wood in the lower edge can be detected. Inside, the painted decoration of the floorboard has been totally destroyed. On the left wall the wood is affected by the same loss detected in the exterior decoration.

Iconography (Exterior)

The upper edge is decorated with a frieze of alternating cobras (multicoloured) and feathers (green). Below, a band of hieroglyphic inscriptions (Inscriptions 1–2) runs from the headboard to the footboard. This inscription is bordered by block-friezes. These motifs are discontinued on the headboard.

The vignettes are bounded by columns of texts (Inscriptions 5–16).

The lower edge is decorated with a band of hieroglyphic inscriptions (Inscriptions 3–4) running from the headboard to the footboard. The area below is decorated with a block-frieze and a thick monochromatic band (black).

Headboard

The headboard is composed of a tripartite panel (Fig. 130).

The *Vignette 1* (centre) shows a symmetrical composition consisting of a large *tjet*-sign (red and blue) adorned with two flowers. On both sides of the knot figure two poles of the West centripetally oriented.

The *Vignette 2* (left side) depicts an offering scene. A goddess clad in a tight dress (green) holds up a vessel before the *Ta-wer*-totem with a pile of offerings at her feet. Short labels refer to '*Isis*' and to the '*great god*' at the back of the totem (Fig. 130).

The *Vignette 3* (right side) is partially damaged (Fig. 136). A mummiform Osiris is seated on a *hwt*-throne resting on a high plinth. The god wears the *hedjet*-crown and grasps the royal scepters. An offering table (below) stands at his feet while a winged cobra embraces the *shen*-ring (above).

Left Side

The left side is decorated with two vignettes (*Vignettes 4–5*). The *Vignette 4* is the longest and displays several scenes.

The upper section is decorated with the two first scenes.

The **first scene** depicts a symmetrical composition with the *sekhem*-scepter at its centre (Fig. 132). This motif is flanked by centrifugal blocks featuring an Osirian shrine. The enthroned mummiform god wears the *hedjet*-crown and grasps the royal scepters, with the *imi-wt*-totem at his feet. Behind him, stands a goddess clad in a tight dress (green) and wearing a hathoric headdress. Short labels refer to the '*great god, lord of the Duat*'.

The scene is completed with centripetal blocks displaying an offering scene performed by two standing goddesses. On the right, the first goddess wears a tight beaded dress and the hathoric headdress. She raises a mat piled with offerings. Another goddess escorts her, clad in a long tight dress (green) and crowned with the pole of the West. She holds *ankh*-signs in both hands. The symmetrical scene on the left side is badly damaged, but two female deities can be detected, both wearing the hathoric headdress. The last one is clad in a long tight dress (green) and raises an offering table. She is referred to as '*Isis*'.

The **second scene** shows the deceased escorted by two goddesses (Fig. 133). At the centre of this group figures a snake-headed goddess, clad in a tight dress (blue) and wearing the sun disk. She radiates light towards the deceased, and holds him by the hand. The deceased has a short beard and wears a tight garment (multicoloured), and an unguent cone. On the left, '*Isis*' holds the snake-headed goddess by her hand. Piled offerings are depicted between the figures. Short labels refer to the '*Mysterious (shrine) in the western Duat*' (next to the deceased), '*Mistress of dread, mistress of the shetyt-shrine, foremost of the burial mounds*' (next to the snake-headed goddess), '*The venerable one before Isis, the great mother, the eye of Re, the mistress*' (next to Isis).

The remaining scenes fall on the lower section.

In the **third scene** the deceased presents offerings to a mummiform falcon-headed god standing under a vaulted shrine. The mummiform god wears the sun disk and grasps three royal insignia (the *heqa*-scepter, the *nekhakha*-flail and a long *was*-scepter). Offerings are piled at his feet. Short labels refer to the '*great god, lord of the Duat*' (next to the falcon-headed god), '*Giving praises*' (next to the deceased).

The **fourth scene** displays an offering scene before a jackal-headed god (Fig. 133). A vulture-headed goddess holds up a vessel and a feather (?) in her hands. Before her, a snake-headed goddess, wearing the sun disk, raises an offer-

ing table on her hands. Both goddesses wear the *ankh*-sign pending from the left arm. Piled offering tables rest at their feet. The jackal-headed god holds the *heqa*-scepter (right hand), the *nekhakha*-flail, and the *ankh*-sign (left hand). Short labels refer to the 'great god, lord of the Duat, foremost of the mysterious burial', and 'great god, lord of the Duat'.

In the **fifth scene**, a goddess performs an offering before two enthroned gods (Fig. 133). The goddess is clad in a tight dress (green) and wears the sun disk. She holds a vase with outflowing ointment. The enthroned god on the right is snake-headed. He wears a sun disk and grasps the royal scepters. His mummiform body (blue) is adorned with red braces. Behind him, a mummiform Osiris sits on a *hwt*-throne under an elaborate vaulted shrine. The god wears the *hedjet*-crown and holds the royal scepters. At the back of the goddess, two registers are depicted. In the upper one two mummiform figures are kneeling on reed mats under a vaulted shrine. The first is human-headed and wears the divine beard while the second is snake-headed. In the lower register a snake-headed mummiform god is squatting on a reed mat resting on a basket while holding a mace. The scene is profusely decorated with liminal elements (cobras, vultures), loose hieroglyphs and offerings creating a confusing effect.

The *Vignette 5* features the sacred cow going forth from the Theban Mountain (Fig. 134). The goddess stands on a reed mat and a *heb*-bowl, facing the headboard. She has a maculated (black-spotted) hide and is adorned with the hathoric headdress, the sistrum and the *menat*-counterpoise. A ritual vessel figures at her feet. A winged cobra outstretches its wings towards the goddess, embracing the *shen*-ring and the *udjat*-eye. The tomb is depicted on the desert cliff. Short labels refer to 'The mistress of the West, who dwells in the West'.

Right Side

The upper section of the right side is decorated with three vignettes (*Vignettes 6–8*).

The *Vignette 6* is totally lost. Traces of a vaulted shrine, offerings and loose hieroglyphs can be detected (Fig. 136).

In the *Vignette 7* most of the painted decoration collapsed, but the general layout is still visible (Fig. 136). Osiris is laying on a bier facing the headboard. He has a curled beard and holds the royal scepters. Above, a cobra rests under a vaulted shrine while a squatting winged goddess is depicted over his body. Short labels refer to 'Isis, the eye of Re' and 'Nephthys'.

The *Vignette 8* displays an abbreviated version of the judgement scene presided by the enthroned Osiris depicted under a vaulted shrine (Fig. 137). The god wears the *hedjet*-crown and grasps royal scepters. A goddess (only her feet

are detected) stands at his back. The Great Devourer is couched before the Osirian throne, entirely shaped as a hippopotamus, and grasping two knives. Three gods stand before the Osirian throne: two goddesses and a mummiform feather-headed god. Short labels refer to the *'venerable one before Isis, the great mother, the mistress [---]'*.

The lower section is decorated with three vignettes (*Vignettes 9–11*).

The *Vignette 9* shows the deceased performing an offering to a vulture-headed goddess (Fig. 137). The deceased has a short beard, and wears a tight garment (multicoloured) and an unguent cone. He is escorted by *'Isis'* wearing a modium. Both figures hold a vase with outflowing ointment. At their feet stand offering tables. The enthroned vulture-headed goddess is depicted under a vaulted shrine. She grasps the *wadjet*-scepter and the *ankh*-sign. Hieroglyphic labels present the formulae *'I am the mistress, the Lady of the West, who is in the Shetyt-shrine, the great goddess'* (vulture-headed goddess) and *'Giving praises to the lord of the Duat'* (deceased).

The *Vignette 10* features the *Ta-wer*-totem at the centre of a symmetrical centripetal composition (Fig. 138). The totem is adorned with a double-feathered solar headdress and it is flanked by two goddesses clad in green tight dresses. They raise one arm while grasping the *imi-wt*-totem with the other. The goddess on the left side wears the hathoric headdress while on the right the deity wears the monogram of *'Isis'*. A mummiform snake-headed god is depicted at the back of each goddess. The god on the left side is labeled as *'who is in the divine shrine'* while the deity on the right wears the *atef*-crown. The upper part of the scene is decorated with *udjat*-eyes resting on reed mat, while piled offerings are depicted at both sides of the totem.

The *Vignette 11* features an offering scene (Fig. 138). Two goddesses present offerings to a standing snake-headed god. The goddess *'Neith'* carries a long necklace with a pectoral, while the other one offers burning incense and a libation vessel. The snake-headed god stands under a vaulted shrine grasping the flail and the *ankh*-sign. A fan (above) and some offerings (below) are piled at his back while an offering table stands at his feet.

Footboard

The footboard remained undecorated.

Iconography (Interior)

The thicknesses are stepped and painted yellow. They have a large exterior border and a narrow interior edge carved at a lower position. The mortars are positioned in the transition from the lower to the higher edge.

The decoration is badly damaged, particularly on the floorboard. Along the sides, the scenes are relatively well preserved. The motifs are painted against a reddish background and the original quality of the painting is excellent.

Headboard

The headboard is decorated with a large falcon depicted under a *pet*-sign (blue, decorated with yellow stars). The avian god outstretches its wings towards both sides of the case. It is rendered in profile looking left, wearing the sun disk. The multicoloured (white, black, green and yellow) feathers are finely executed. Under each wing there is a squatting mummiform deity. Above, figures a vulture resting on the *nebu*-sign with the *ankh*-sign at its feet. These figures are transversally aligned with the vertical registers depicted on the sides (Fig. 139).

Another large *pet*-sign (blue, decorated with yellow stars) separates the decoration of the headboard from the decoration of the sides.

Sides

Below the starry band, on both walls of the coffin, figure three perfectly symmetrical registers (centrifugally oriented).

In the first register four standing mummiform deities wear red braces and multicoloured *usekh*-collar. The first deity is human-headed, the second is jackal-headed, the third is baboon-headed and the fourth is falcon-headed. A libation stand figures at the feet of each god. Short labels refer to '*The great god, the lord of the Duat, the foremost of the divine shrine, lord of the necropolis*' (right side) and '*The great god, lord of the Duat, foremost of [---]*' (left side).

The second register follows the same composition. The first deity has the pole of the West in place of the head and he is preceded by a lettuce vase. The second, is a snake-headed god and he is preceded by the pole of the West. The third and the fourth deity are respectively vulture-headed and lion-headed and they are preceded by libation stands. Short labels refer to the '*Lord of the Shetyt-shrine, foremost of the burials*'.

The third register shows a cobra-headed deity preceded by a lettuce, followed by a deity with the pole of the East in the place of the head and the pole of the West at his feet. The third deity has the pole of the West in the place of the head and he is preceded by a libation stand. The fourth deity is snake-

headed (wearing the sun disk) and he is preceded by a libation stand. Short labels refer to ‘*Lord of the Shetyt-shrine, lord of the Duat*’.

Inscriptions

Long bands of inscription (Inscriptions 1–2) run along the upper edge bordered by multicoloured block-friezes. The texts are outlined in red against a yellow background, with details painted in green, blue and red. The calligraphy is cursive, but some hieroglyphs are fairly detailed such as the squatted gods with elaborate scepters and crowns (Inscription 1) or the squatted king with a scepter and an *iaret*-cobra on his forehead (Inscription 2). Both the inscriptions face the headboard. A space was left blank for the writing of the name of the deceased.

Inscription 1

h̄tp[-di-nsw n R̄-h̄r-ḥty]-tm, ḥkꜣ tꜣwy, Íwnw[y], ḥnty sh-ntr, ḥr[y]-ib Nwbt[?], dī.s[n] ḥtpw, ḏfꜣw nw s̄ht-ỉrw, ḥr[y]-ib tꜣ-dsr, ntrꜣ, ḏḏw, ḥr[y]-ib ȝbdw. dī.s pr bꜣ.f/i mꜣꜣ[.i] itn wbn.f, tm ḥtp.f ḥpr[.i] [m?] bꜣ ḥnh, ṣsp[.i] ḥtp[w] ḥr db[h]t[ḥtp] nw s̄ht-ỉrw, ḥr[y]-ib tꜣm dīw [n.]k [?] irp, (m)r̄ḥt ḥtpw ḏfꜣw [n] [Space left blank for the name].

An offering [that the king gives to Re-Harakhty-]Atum, the ruler of the Two Lands, the Heliopolitan, the foremost of the divine shrine, who dwells in Nubet[?], so that they[sic, read: he] may give offerings and provisions from the Fields of Reeds, who dwells in the Sacred Land, the great god of Busiris, who dwells in Abydos, may he give that my ba may go forth to see Aten when he rises and Atum when he sets, and may I become a living ba, receiving offerings from the altar of the Fields of Reeds, who dwells in Tam [=Djeme=(modern) Medinet Habu], and may be given [to] you wine, ointments, offerings and provisions [Space left blank for the name].

Inscription 2

h̄tp-di-[nsw] [n] Wsir, [nb] nh̄h, ḥnty-[] [Ímntt], ḥr[y]-ib s̄ht-ỉrw [---][ḥt] nb[t], nfr[t], wꜣb[t] [] dī.s ḥtpw ḏfꜣw, ḥt-nb[t] nfr[t] wꜣb[t], ndm[t], nty ḥnh ntrw im[.s], dī.s ḥtpw ḏfꜣw nty Ímntt, pr bꜣ.f mꜣꜣ (sic) [read: mꜣꜣ] Ítn wbn.f, tm ḥtp.f, r-nb [Space left blank for the name].

An offering that [the king] gives [to] Osiris, the [lord] of eternity, the foremost of the West, who dwells in the Fields of Reeds, [---], all good and pure things, [all]

things [] may she [sic, read: he] give offerings and provisions, everything good and pure, everything good and sweet on which the gods live, and may she [sic, read: he] give offerings and provisions from the West, so that his[sic, read: my] ba may go forth to see Aten when he rises and Atum when he sets, every day of his. [Space left blank for the name].

Two other inscribed bands bordered by a thick black line (above) and a multicoloured block-frieze (below) run along the lower edge from the headboard to the footboard (Inscriptions 3–4). The texts face the headboard. The hieroglyphs are outlined in red and coloured with other pigments (green, blue and red). Calligraphy tends to be cursive.

Inscription 3

ink 3st [wr.t, mwt ntr, irt] R^c, hnwt [---] n hsyw m W3st. di' tw diw htpw, h3[:f] [m] imnt-W3st, k.k/i n hsyw, šsp t hnkt, k3w, 3pdw, kbhw, sntr, di.s krs[t] nfrt, hr-ib imnt-W3st, [m-m?] ntr[w] ntr[wt] imi pt, ntr[w] ntr[wt] imi t3

I am Isis, [the great, the mother of the god, the eye of] Re, the mistress [---] to the praised ones in Thebes; may gifts be given and offerings and may he/you go down in/out of [?] the West of Thebes and enter among the favorites, receiving bread, beer, oxen, fowl, libations, frankincense and may she give a beautiful burial in the West of Thebes among the god[s] and goddess[es] who are in the sky and the god[s] and goddess[es] who are in the earth.

Inscription 4

dd mdw in 3st, wrt, mwt [ntr], irt R^c [---] hr[yt]-ib Imntt, hnty[t] sh-ntr, di.s htpw dfrw ht-[nbt] nfr[t] w^cb[t], ht-[nbt] nfr[t] ndm[t], m [-ist-] n [] wr, hnty sh-ntr, Wsir, hsy, s3[?] hsyw m W3st. dd.f ink [?] k m-b3h Psdt-3[t], šsp.k [sis] htpw ntyw [m] imntt, imy-wrt W3st.

Words to be spoken by Isis, the great one, the divine mother, the eye of Re, [---] who dwells in the West, foremost of the divine shrine. May she give offerings and provisions, everything good and pure, everything good and sweet from [---] the mound of [] the great, the foremost of the divine shrine, the Osiris, the venerable one, son[?] of the venerable ones in Thebes. He says: 'I am [] one who enters before the Great Ennead so that I may receive the offerings which are in the west, the west of Thebes'.

The other texts (Inscriptions 5–16) are written in columns bordered by vertical lines (black). All the inscriptions face the headboard. The texts are outlined

in red and coloured green, blue and red. The left side displays 4 inscriptions (Inscriptions 5–8).

Inscription 5

imꜣhy [*hr ntr ʿ3*] *nb dwꜣt*

The venerable one [before the great god], *lord of the Duat*.

Inscription 6

(col. 1) *imꜣhy hr Nbt-hwt, snt ntr, jrt* [*Rʿ?*], *hnwt pr-ꜣnh*

(col. 2) *di.s prt-hrw t, hnkt, sntr, kꜣw, ʿpdw, ht-nb* [*t*] *nfrt wꜣbt*

(col. 1) *The venerable one before Nephthys, the divine sister, the eye of Re* [*?*], *the mistress of the House of Life* (col. 2) *that she may give an invocation-offering consisting of bread and beer, frankincense, oxen, fowl, everything good and pure.*

Inscription 7

(col. 1) *imꜣhy hr hnwt Imn* [*tt*], *nbt*

(col. 2) *tꜣ-dsr*, [*imꜣh*] *y hr hnwt Imn* [*tt*], *nbt*

(col. 1) *The venerable one before the mistress of the West, the mistress of* (col. 2) *the Sacred Land, the* [*vener*] *able one before the mistress of the West, the Lady.*

Inscription 8

(col. 1) *imꜣhy hr ntr ʿ3, nb dwꜣt imntt*

(col. 2) *imꜣhy hr hnwt Imn* [*tt*], *nbt*

(col. 1) *The venerable one before the great god, lord of the Duat and the West*
(col. 2) *The venerable one before the mistress of the West, the Lady.*

The right side displays 8 inscriptions (Inscriptions 9–16). Next to inscription 16, a large depiction of the pole of the West figures in one column of inscription (cf. inner case of A.60).

Inscription 9

(col. 1) [---] *n* [*?*] *Wsir nb nhꜣ* [---]

(col. 2) *Wnn-nfr hkꜣ ʿnhw ntr ʿ3*

(col. 1) [---] [*to/for?*] *Osiris, lord of eternity*, [---] (col. 2) *Unnefer, ruler of the living, the great god* [---].

Inscription 10(col. 1) *ink ḥnwt Ḳmntt, nb[.t] išt-dsr[t]*(col. 2) *imꜣḥy ḥr Nbt-ḥwt, snt ntr, irt Rꜥ, ḥnwt [---]*

(col. 1) *I am the mistress of the West, the lady of the sacred mound,* (col. 2) *The venerable one before Nephthys, the divine sister, the eye of Re, the Mistress of [---].*

Inscription 11*[imꜣḥy ḥr] sst, wrt, mwt ntr, [irt Rꜥ]*

[The venerable one before] *Isis, the great one, the divine mother,* [the eye of Re].

Inscription 12*[---]***Inscription 13**(col. 1) *imꜣḥy ḥr ntr ꜣ, nb dwꜣt, ḥnty šḥ-ntr*(col. 2) *imꜣḥy ḥr Wsir, nb nḥḥ, ḥnty Ḳmntt*

(col. 1) *The venerable one before the great god, lord of the Duat, the foremost of the divine shrine.* (col. 2) *The venerable one before Osiris, lord of eternity, the foremost of the West.*

Inscription 14*imꜣḥy ḥr ntr ꜣ, nb dwꜣt, tꜣ-[dsr?]*

The venerable one before the great god, the lord of the Duat and of the [Sacred?] Land.

Inscription 15(col. 1) *imꜣḥy ḥr ntr ꜣ, nb dwꜣt*(col. 2) *imꜣḥy ḥr ntr ꜣ, nb dwꜣt*

(col. 1) *The venerable one before the great god, lord of the Duat* (col. 2) *The venerable one before the great god, lord of the Duat.*

Inscription 16*imꜣḥy ḥr ntr ꜣ, nb dwꜣt*

The venerable one before the great god, lord of the Duat.

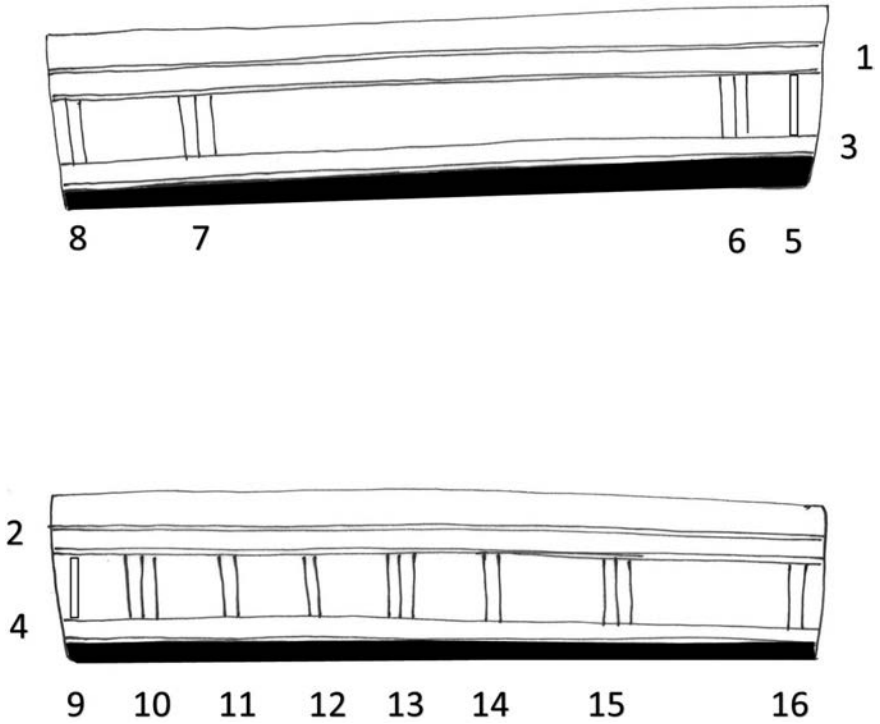

FIGURE 126 Case (A.56). Inscriptions

1



2

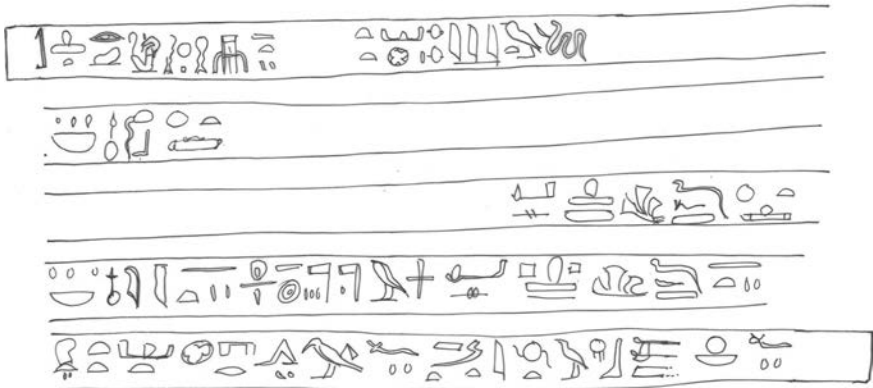
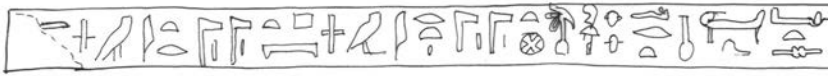

FIGURE 127 Case (A.56). Inscriptions 1-2

3



4

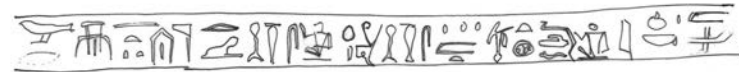
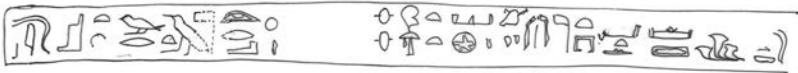

FIGURE 128 Case (A.56). Inscriptions 3-4



8



7

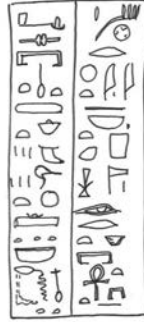

6



5

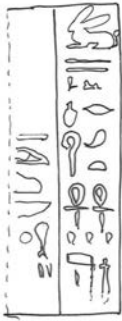

9



10



11



13



14

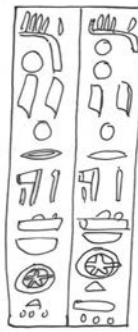

15



16

FIGURE 129 Case (A.56). Inscriptions 5-16



FIGURE 130 Case (A.56). Headboard



FIGURE 131
Case (A.56). Left side



FIGURE 132 Case (A.56). Left side, upper section



FIGURE 133 Case (A.56). Left side, middle section



FIGURE 134 Case (A.56). Left side, lower section



FIGURE 135
Case (A.56). Right side



FIGURE 136 Case (A.56). Right side, upper section



FIGURE 137 Case (A.56). Right side, middle section



FIGURE 138 Case (A.56). Right side, lower section



FIGURE 139
Case (A.56). Interior decoration (left side)

Coffin Set of an Anonymous Woman (A.60)

Summary description: Outer anthropoid coffin (14–15), inner anthropoid coffin (16–17) and mummy-cover (18).

Archaeological context and dating: The coffin set was found in the main gallery of Bab el-Gasus¹ next to the western wall. The scheme of decoration detected on the inner coffin relates to the first half of the 21st Dynasty, while the outer coffin displays late features. Nothing can be said about the remaining objects that were included in this burial assemblage nor about the identity of the owner.²

Name and titles of the owner: The equipment of this coffin set presents abundant traces of usurpation. The outer lid shows male features and the name of Ankhefekhonsu (its first owner) is outlined in red on the case (Inscription 1). Nevertheless, the inner coffin, much older than the outer coffin, shows female features. The mummy-cover was originally crafted for a man, but female features were added (namely earrings and open hands). In the inscriptions of the mummy-cover the name Ankhesenmut is written.

1 In the scheme proposed by Niwiński (1988, pp. 196–197 Table 1), A.60 seems to have been superimposed on the coffin A.59. Daressy on the other hand (1900, p. 147), indicates that A.60 lay below A.59. Our plan of the tomb follows Daressy notes. Material evidence seems to corroborate this reading: A.60 is a coffin set, while A.59 is a single inner coffin (see Niwiński 1988, p. 110 n. 36) that could have never supported such a weight. The bad state of preservation of the outer coffin from A.60 can also be explained in this way.

2 Aston 2009, p. 174 n. TG 733. The attribution of inscribed linen and part of a jersey is derived from Porter and Moss (see PM 1,2 p. 637) but this is probably a misunderstanding and the quoted clothes are probably no other than the '*campioni delle stoffe rinvenute a Deir el Bahri insieme alle Mummie dei faraoni*' asked by Schiaparelli and arrived in Florence at the same time than Lot v.



FIGURE 140 Coffin set (A.6o)

14. Outer Lid

Museum inventory number: 8523

Length: 218 cm; Width (max): 71 cm

Wood, plaster, paint, varnish.

Decorated with multicoloured paintwork and occasional use of moulded plaster.

The ears, the beard (now lost) and the hands have been carved in wood and attached to the lid.

The reverse side of the object is undecorated, as well as the underside of the footboard.

The headboard is badly damaged. The paint and the plaster collapsed on the wig and on the face. The right ear and the beard are lost. A long crack runs down the central axis of the object, from the fists to the footboard. The plaster and the painted decoration collapsed in the lower section and in most of the footboard.

Iconography

Headboard

The painted decoration has faded away and some of the plaster that covered the object collapsed. Nevertheless it is possible to detect vestiges of the original painted decoration (Figs. 145–303). The wig was decorated with a striped pattern (black and yellow). The face was finely moulded in plaster and painted in yellow. The lappets of the wig were adorned with terminals (yellow).

On the chin it is possible to detect the hole for the pin of the beard.

Upper Section

The fists are painted yellow and crossed over the chest (Fig. 145). They show holes carved for embedding large amulets (now lost). The area comprised between the lappets of the wig presents vestiges of a short collar decorated with transversal bands (light green, dark green and red).

On the chest, between the fists, it is possible to detect the remains of a pectoral featuring a solar-headed heart amulet flanked by *iaret-cobras*. Vestiges of a necklace or mummy braces can also be detected.

The remaining decoration of the floral collar shows that it comprised at least ten bands decorated with a diversified sample of patterns: persea-tree buds

(2nd, 10th bands), checkered motifs (3rd, 5th, 7th bands), lotus petals (2nd, 4th, 8th bands), buds on reeds (6th, 9th bands), lotus flowers intertwined with persea-tree flowers (1st band).

Central Panel

The central panel displays three registers (Fig. 146–147). Some of the motifs of the composition are moulded in plaster to suggest relief, such as the scarabs, the bodies of the enthroned gods, the *hwt*-thrones, the solar disks, the hair and the body of the goddess. The edges of the tableau are decorated with multi-coloured block-friezes.

The first register shows a symmetrical composition. The nuclear block features a scarab rising from the *nebu*-sign and holding up a solar disk in its forelegs. The *shen*-ring figures between the hind legs. This nuclear composition is flanked by centrifugal blocks featuring two enthroned gods, Osiris and 'Isis'. Osiris grasps the royal scepters and wears the *hedjet*-crown. Isis wears the sun disk (red) and embraces him. The composition is completed with centripetal blocks featuring a winged goddess squatted on the *nebu*-sign.

The second register is bounded by a transversal block-frieze and a large *pet*-sign. It features the winged goddess outstretching her wings towards both sides of the lid. She wears a solar disk (green) and a tight dress (green). Liminal elements are displayed above the wings of the goddess forming a symmetrical sequence of scarabs holding the solar disk, squatting deities, vultures, falcons, cobras and *shetyt*-shrines.

The third register is better preserved and it is identical to the first one. The nuclear block features the scarab rising from the *nebu*-sign holding up a solar disk (green). The centrifugal blocks include the depiction of two enthroned gods, Osiris and Isis. The centripetal blocks feature a goddess wearing the solar disk (red). She is squatted on a reed mat and the *nebu*-sign outstretching her wings towards Osiris. A sacred vulture resting on a *neb*-basket is depicted under her wings.

Along the edges of the composition, additional blocks form a sequence of four registers. From top to bottom one detects the *Ta-wer*-totem standing on a reed mat crowned with a double-feathered solar headdress. Four *ia-ret*-cobra crowned with the hathoric headdress spring from the cap of the totem. The *imi-wt*-totem stands next to it. In the second register figures a squatting mummiform god wearing the *hedjet*-crown. The third register shows a squatting mummiform god. The fourth register features a standing lotus-scepter crowned with the double-feathered solar headdress. The *imi-wt*-totem stands before the flower, while the pole of the West is depicted at its back. An abundant use is

made of liminal elements (*shetyt*-shrines, vultures, falcons and cobras) which are depicted all around the main figures.¹

Lower Section

This section is arranged in three longitudinal partitions, entirely bounded by block-friezes (Figs. 148–149). The central partition is flanked by two longitudinal columns of text (Inscriptions 1–2) bounded by block-friezes. It displays three registers, each one decorated with a symmetrical composition involving a nuclear block featuring a scarab holding up the solar disk (green) in its forelegs, with the *shen*-ring depicted between its hind legs. Most of the motifs are moulded in plaster to suggest relief (scarabs, solar disks, baskets).

In the first register the centripetal blocks feature a mummiform deity wearing a solar disk (red) squatted on the *nebu*-sign. In the second register, the nuclear composition is flanked by centrifugal blocks featuring a mummiform snake-headed deity wearing the solar disk, squatted on the *nebu*-sign. The god grasps the *ankh*-sign. In the third register the centripetal blocks feature a mummiform deity wearing a solar disk (red) squatted on the *nebu*-sign.

The lateral partitions display three registers divided by transversal block-friezes. Each scene depicts the deceased performing offerings before an Osirian shrine. The deceased wears tight garments and the *usekh*-collar. He has short beard. The vault (black and red) of the Osirian shrine is supported by a *djed*-column. Inside, figures an enthroned Osiris with the *imi-wt*-totem (moulded) at his feet. The mummiform god (black body, moulded) wears the *hedjet*-crown (moulded).

In the first register the deceased is preceded by a green-skinned goddess carrying a *menat*-counterpoise. The *udjat*-eye is depicted in front of the enthroned Osiris. In the second register, the goddess and the deceased kneel before the shrine (right side), while on the left side the fragments left in situ show a standing mummiform god instead. In the third register, the deceased is kneeled (right side), while on the left side he is standing.

Footboard

The footboard follows the same tripartite organization observed in the lower section (Fig. 150). The lower edge is decorated with a multicoloured block-frieze. The central partition is inscribed with three columns of hieroglyphic inscriptions (Inscriptions 3–5) bounded by Inscription 1 and Inscription 2.

¹ Interesting parallels with this composition can be found on the lid of the outer coffin of A.23 kept in Cairo (Egyptian Museum, CG 611). See Niwiński 1996, 135–141.

The lateral partitions are badly damaged on both sides, but traces of four registers can be detected (Fig. 302).

The first register shows traces of an offering scene.

The second and third registers are rotated ninety degrees with respect to the first register, showing vaulted shrines. In the second register only the feet of the figures are still visible. A goddess clad in a long tight dress stands before a mummiform (?) god, who grasps a long scepter. The third register depicts a mourning scene. Only the upper part of the green-skinned body of a mourning goddess can be detected. She is squatting with upraised arms before Osiris. The god wears the *hedjet*-crown and grasps the *was*-scepter.

The fourth register displays a reversed vignette depicted under a vaulted shrine. The decoration on both sides collapsed, but a mummiform god wearing the *hedjet*-crown and grasping a long *heqa*-scepter can be detected. A goddess (?) wearing the sun disk is depicted before him.

Inscriptions

The lid displays five longitudinal inscriptions (Inscriptions 1–5). The hieroglyphs are outlined in red against a yellow background, with motifs painted in blue, green and red. The calligraphy is good with some of the signs carefully rendered, such as the solar barque (Gardiner P1).

Inscription 1

*h*tp-di-nsw [n] Wsir, nb nhh, hnty Imntyw, ntr ʿ3, nb dw3t, [di.f] h3 m 3pdw, h3 m sntr[?], h3 m [mnht ---]

An offering that the king gives [to] Osiris, Lord of Eternity, foremost of the Westerners, great god, lord of the Duat, [so that he may give] a thousand of fowl, a thousand of frankincense[?], a thousand of clothing [---].

Inscription 2

*h*tp-di-nsw n R^c-hr-3hty-tm, nb t3wy, hwnwy, ntr [ʿ3], h3 m wi3f, di.s [sic, read: "f"] htpw [---] h3 m sntr[?], h3 m [mnht, h3 m ht-nb[t] ---]

An offering that the king gives to Re-Horakhty-Atum, lord of the Two Lands, the Heliopolitan/and of H., the [great] god who appears in his barque, may he give offerings [---] a thousand of frankincense, a thousand of [clothing, a thousand of all things [--- Space left blank for the name].

The central partition of the footboard is inscribed with three columns of text (Inscription 3–5).

Inscription 3

dd mdw in R-ḥr ʒḥty-tm, nb tʒwy [---]

Words to be recited by Re-Harakhty-Atum, lord of the Two Lands, [---].

Inscription 4

ink Nbt-ḥwt, ntr[t] ʒ[t], [ḥnwt] pr-nfr; d̄i.s [ḥtp ---] ḥt nb[t] [---]

I am Nephthys, the great god[dess], mistress of the House of Embalming, that she may give offerings [---] everything [---].

Inscription 5

Lost

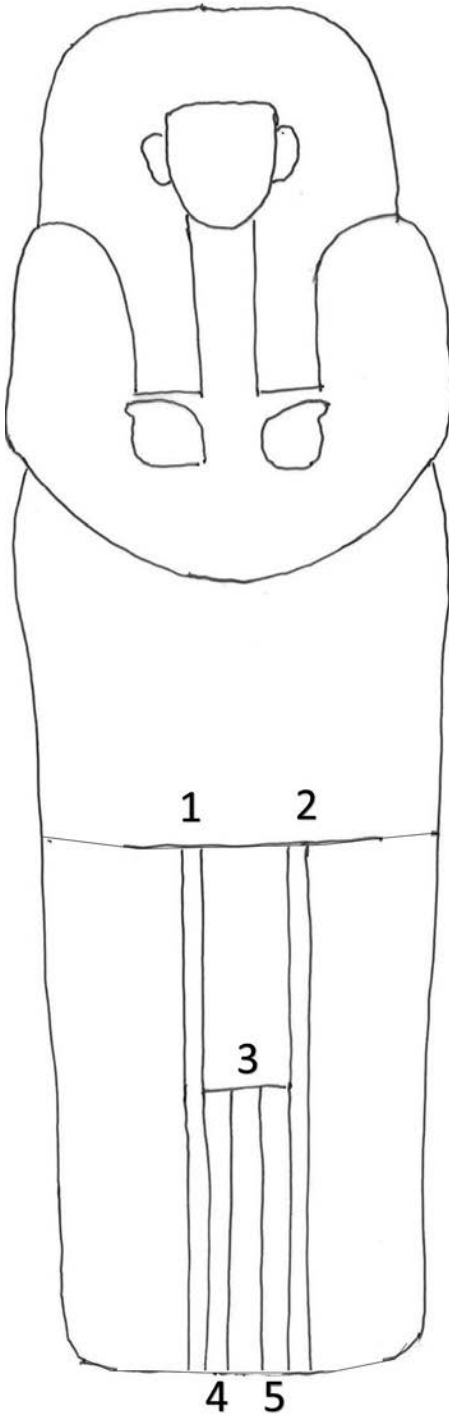

FIGURE 141
Outer lid (A.6o). Inscriptions

1



2



FIGURE 142
Outer lid (A.60). Inscriptions 1-2

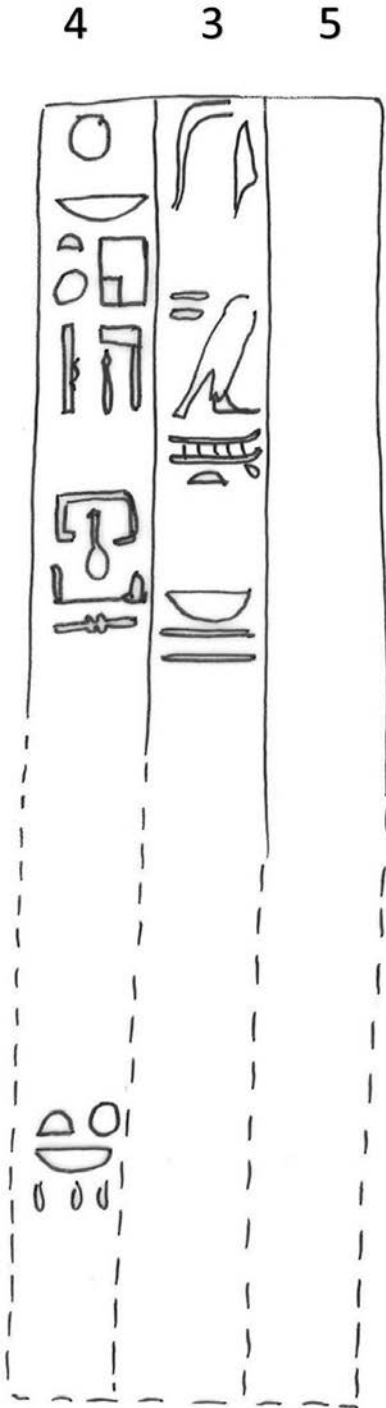

FIGURE 143
Outer lid (A.60). Inscriptions 3-5



FIGURE 144
Outer lid (A.60)



FIGURE 145 Outer lid (A.60). Headboard and upper section



FIGURE 146 Outer lid (A.6o). Central panel

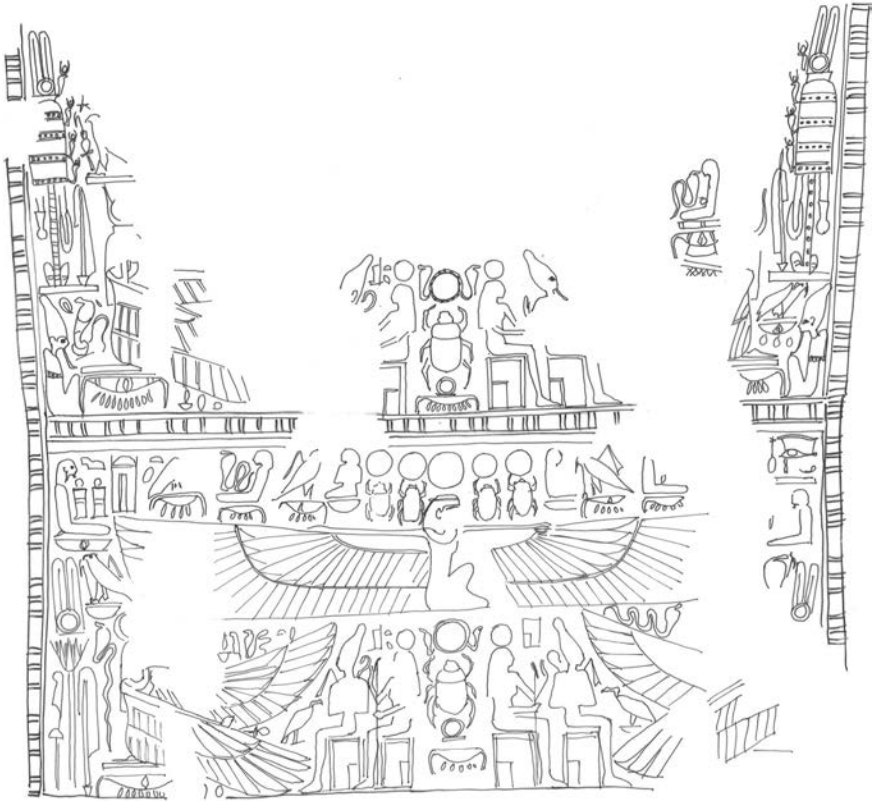

FIGURE 147 Outer lid (A.60). Central panel (drawing)



FIGURE 148 Outer lid (A.60). Lower section

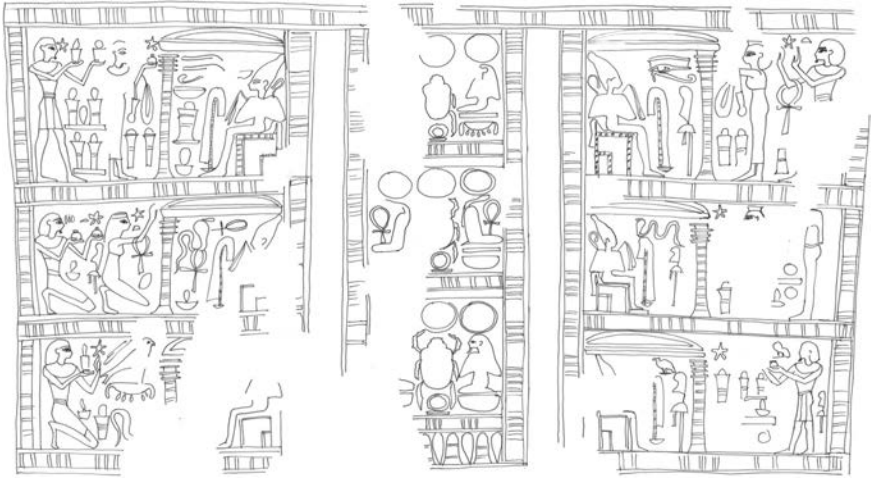

FIGURE 149 Outer lid (A.60). Lower section (drawing)



FIGURE 150 Outer lid (A.60). Footboard

15. Outer Case

Museum inventory number: 8523

Length: 218 cm; Width (max): 71 cm; Depth: 43 cm

Wood, plaster, paint and varnish.

Decorated with multicoloured paintwork.

The object shows several cracks along the whole surface. The exterior decoration of the side walls is badly damaged, especially on the headboard and the upper section. Several cracks can be detected on the whole interior surface, but the interior decoration is preserved in good condition.

Iconography (Exterior)

The upper edge is decorated with a frieze of alternating cobras (multicoloured) and feathers (green). Below, a band of hieroglyphic inscriptions (Inscriptions 1–2) runs from the headboard to the footboard. This inscription is bordered by block-friezes.

The vignettes are bounded by a thick monochromatic band (above), a thin line (below) and columns of texts (Inscriptions 3–17).

Along the lower edge runs a block frieze and a thick monochromatic band.

Headboard

The headboard is composed of a tripartite panel, with the sides (*Vignettes 2–3*) centripetally oriented.

The *Vignette 1* (centre) shows a symmetrical composition with a large *tjet*-sign (outlined in red and blue) flanked by the poles of the West (centripetally oriented).

The *Vignette 2* (left side) is badly damaged, but a ritual lustration scene can be detected showing the deceased pouring water over a god (Fig. 155). The title ‘*Osiris, lord of the burial*’ is written at the back of the god. A couched jackal rests between the two figures.

The *Vignette 3* (right side) depicts an unusual scene (Fig. 159). The deceased wears tight garments (shirt and kilt) and turns backwards while moving away from the *Ta-wer* totem. The deceased holds up a vessel before an offering stand. The *Ta-wer*-totem is crowned with a double-feathered solar headdress and it is adorned with the *menat*-counterpoise. The totem is flanked by the *imi-wt* and the pole of the West. Above, figure the *udjat*-eye, the *nefer*-sign and short labels, such as ‘*Anubis, foremost of the West*’ and ‘*Giving praises to Osiris lord of the burial*’.

Left Side

The left side is decorated with two vignettes (*Vignettes 4–5*).

The *Vignette 4* shows a symmetrical composition on the upper section (Fig. 155). The nuclear block features the *Ta-wer*-totem crowned with the double-feathered solar headdress and adorned with the *menat*-counterpoise. The totem is flanked by centrifugal blocks depicting a god crowned with the sun disk with a pending cobra wearing the *hedjet*-crown. The god has curled beard and wears a tight garment (shirt and kilt) with the *usekh*-collar. He grasps the *nekhakha*-scepter in one hand and a tall *heqa*-scepter with the other. The *imi-wt*-totem stands at his feet. The composition is completed with centripetal blocks featuring the deceased wearing tight garments, short beard and the *usekh*-collar. His head is adorned with an unguent cone and a lotus bud. He raises his arms in adoration towards the solar god. Short labels refer to ‘*Giving life to Osiris, lord of the burial*’ (next to the totem), ‘*the great god, lord of the Duat*’ (next to the god) and ‘*Giving praises*’ (next to the deceased).

The *Vignette 5* is displayed along the lower section featuring several scenes.

In the **first scene** the god ‘*Osiris, lord of the burial*’ is depicted facing the headboard, wearing braces (red) and a long garment (black) typically used in the Heb Sed (cf. footboard of the outer lid). He has a curled beard, wears the *atef*-crown and grasps a long *heqa*-scepter (Fig. 156). At his feet figures the *imi-wt*-totem and the pole of the West surmounted by the sacred falcon. The sacred animal wears the *hedjet*-crown and it is adorned with the *menat*-counterpoise. The formula ‘*Giving life and strength*’ is written at the back of the god.

The **second scene** depicts an offering ritual (Fig. 156). The deceased holds up a vessel before the green-skinned god. The deity wears a tight garment (kilt and shirt) and his head is adorned with a red scarf. An offering table stands at his feet. Short labels refer to ‘*Giving praises to Osiris, the lord*’, ‘*great god, lord of the burial, the ruler of the Duat, so that Re may grant the going forth [---]*’.

The **third scene** depicts the deceased performing a libation before Osiris and Isis (Fig. 156). The deceased pours water over a pile of offerings. The mummy-form Osiris wears braces (red) and the *hedjet*-crown. Isis wears the modium with her monogram and holds a *menat*-counterpoise. An offering mat figures at her feet. Short labels refer to ‘*Giving libations*’, ‘*Osiris, lord of the eternity, foremost of the West*’, ‘*I am Isis, mother of the god, mistress of the House of Embalming. That she may give (offerings)*’.

The **fourth scene** shows the deceased performing a lustration ritual towards a falcon-headed god (Fig. 157). The deceased holds up a vessel with outflowing liquid. The green-skinned god grasps the *ankh*-sign. An offering table stands at

his feet. Short labels refer to ‘*Giving libations and offerings to Osiris lord of the burial*’, ‘*Giving praises to Re-Harakhty-Atum*’.

The **fifth scene** displays an Osirian ritual, where the deceased is depicted twice (Fig. 157). He figures before Osiris, raising his arms and grasping the *sekhem*-scepter. The standing Osiris wears the *hedjet*-crown and holds a long *heqa*-scepter. The deceased also figures at the back of the god, raising his left arm to hold the god. Two kneeling mummiform gods accompanied with offerings are depicted in two registers behind Osiris. This scene shows a profuse use of ritual objects: fans and *shen*-rings, the symbol of the offerings (above) and two *meret*-cases (below).¹ Short labels refer to ‘*Anubis*’ (next to the deceased), ‘*Osiris, lord of the burial*’ (next to the mummiform god) and address the formula *I am Anubis, who dwells in the divine shrine*’ (next to the last god).

Right Side

The right side is decorated with a single vignette (*Vignette 6*), displaying five different scenes.

The **first scene** is entirely painted on the upper section, featuring an offering ritual before the sacred barque (Fig. 159). The deceased holds up two vessels before a pile of offerings at his feet. The pole of the West is depicted at his back. Two male deities stand before him, grasping the rope for pulling the barque. They wear tight garments, the *usekh*-collar and a curled beard. The pole of the West is depicted between them. Behind the two gods figures the sacred barque (multicoloured), resting on the lake-sign.

A red swallow rests on the neat that pends from the prow of the solar barque. Five deities are carried on the barque. A goddess stands before four gods. She wears a tight beaded dress (red) and the monogram of Neith (but the name ‘*Isis*’ is depicted before her). The gods are clad in tight garments, grasp *nekhakha*-flails and wear a red scarf on their heads. A coiled snake bearing the *ankh*-sign pending from its neck is depicted above the divine crew. Above the stern figures a standing baboon with raised arms, while at the prow a sacred falcon rests on the pole of the West followed by a sacred cobra bearing the *shen*-ring pending from its neck. Two fishes are depicted below the barque jumping out from the water. Short labels address the formulae ‘*Anubis, who dwells in the sacred shrine*’, ‘*Rejoicing to Re-Harakhty-Atum, lord of the Two Lands, the Helipolitan, great god that rises in [---]*’.

¹ A variation of this motif is also found in the inner coffin A.23 at the Egyptian Museum of Cairo (CG 6112; Niwiński 1996, 139 fig. 110).

The remaining scenes are featured on the lower section.

The **second scene** shows the deceased performing a lustration ritual towards a shrew-headed (?) god (Fig. 160). The deceased holds up a vessel with outflowing liquid. The green-skinned god wears a blue garment and the *usekh*-collar. The hieroglyphic inscriptions depicted in the upper part of the scene bears the formulae '*Rejoicing to Re*' and '*Purifying Re*', while short labels refer to '*Anubis, purifier and lector-priest*'.

The **third scene** features an offering scene performed by the deceased before the mummiform Osiris (Fig. 160). The deceased turns backwards holding up a vessel with burning incense (cf. *Vignette 3*). A vessel and an offering mat figure at his feet. Osiris has curled beard and wears the *hedjet*-crown, while grasping a long *heqa*-scepter. His body (black) is adorned with braces (red). The pole of the West and the *imi-wt*-totem are depicted at his feet. Short labels address the formulae '*Giving praises to Osiris, lord of the burials, foremost of the West*', '*Giving praises to Anubis*' (next to the deceased)

The **fourth scene** shows the deceased with his arms raised in adoration towards a green-skinned god wearing a red scarf (Fig. 160). The deity grasps a long *heqa*-scepter, the *nekhakha*-flail and the *ankh*-sign. The *imi-wt*-totem and a vessel stand at his feet. Short labels address the formulae '*Giving praises to Osiris, lord of the mysterious Duat, foremost of the West*', '*I am the great god, lord of the mysterious Duat, who goes forth*'.

The **fifth scene** features the sacred cow going forth from the Theban Mountain (Fig. 161). The goddess stands on a reed mat and a *heb*-bowl, facing the headboard. She is adorned with the hathoric headdress and the sistrum. At her feet figure ritual vessels and offerings. The goddess is breastfeeding the *ba*-bird who figures under her starry body. A lamp burns at the feet of the *ba*-bird. Above, a winged cobra outstretches its wings towards the goddess, embracing the *shen*-ring. Two mummiform deities are depicted behind, kneeling on a *heb*-bowl. The tomb is depicted at the edge of the scene as standing on the Theban Mountain. Loose hieroglyphs and offerings are depicted in the interstitial areas of the composition.

Footboard

The footboard remained undecorated.

Iconography (Interior)

The thicknesses are stepped and painted yellow. The mortars (four at each side) are positioned in the transition from the lower to the higher edge.

The decoration is painted against a reddish background.
Two longitudinal cracks run along the floorboard.

Headboard

The headboard is decorated with the avian manifestation of the deceased flying under the *pet*-sign (blue). The *ba*-bird outstretches his wings towards both sides of the case (Fig. 162). The head is rendered in full frontal view and painted in yellow. He has a short beard. The feathers are multicoloured (white, dark and light green). Under each wing, in transversal position, there is a sacred cobra wearing the sun disk. The formula '*Going forth to the Duat*' is inscribed over each wing. These hieroglyphs are transversally aligned with the vertical registers depicted on the sides.

Another large *pet*-sign (blue) separates the decoration of the headboard from the decoration of the sides.

Sides

The decoration of the sides is symmetrical, each one displaying three registers (centrifugally oriented).

In the first register four mummiform deities stand on a *heb*-bowl wearing red braces (Fig. 164). The first deity is human-headed, the second is falcon-headed, the third is vulture-headed and the fourth is hare-headed. Each deity is preceded by a libation stand. The pole of the West stands before the first god. Short labels refer to '*The great god, foremost of the West, lord of fear, lord of dread*'.

The second register follows the same composition. The first deity is preceded by the pole of the West and is cat-headed, the second is hippopotamus-headed, the third one is a double-snake-headed (with a solar disk between the heads) and the fourth has human face depicted in frontal view. Each deity is preceded by a libation stand. Short labels refer to the '*Lord of fear, foremost of the Duat, lord of dread*' (left side) and '*Lord of fear, foremost of the Duat, manyfold of faces*' (right side).

In the third register only three deities are depicted. The first is human-headed and he is preceded by the pole of the West, the second is snake-headed and the third is flame-headed. Each deity is preceded by a libation stand. Short labels refer to '*The great god, the lord foremost of the burial of the Duat, lord of fear*'.

Floorboard

The floorboard displays three registers bounded by large *pet*-signs (blue).

The first register features a sun disk rising between the Lions of the Horizon (yellow) holding knives in their forelegs (Fig. 163). The whole composition

is surmounted by the 'dome' of heaven (a curved *pet*-sign), and rests on a *pet*-sign (cf. inner case from A.15).

The second register shows a large mummiform Osiris (white body) standing on a *heb*-bowl. The green-skinned god is crowned with a striped *atef*-crown (multicoloured) provided with ram's horns and a solar disk. He has a curled beard, wears the *usekh*-collar and grasps the royal scepters. Note that the fists are not crossed over the chest (cf. floorboard of the outer case from A.15). The slim mummiform body of the god is entirely painted in white.

The god is flanked by several motifs arranged in five secondary registers.

On the right side of the case, a sacred cobra bears the *shen*-ring pending from its neck. In the second register, another cobra bears the *ankh*-sign. In the third register figures a squatted mummiform snake-headed god (centrifugally oriented). In the fourth register the decoration is damaged but a sacred cobra can be detected. The fifth register depicts a sacred cobra and a mummiform hare-headed god (centripetally oriented) resting on the *pet*-sign. A short label refers to the *'Lord of dread'*.

On the left side, the composition is headed by a sacred cobra (above) outstretching its wings towards Osiris. The goddess wears the sun disk and bears the *ankh*-sign pending from her neck. The sacred vulture resting on a *heb*-bowl is depicted below. The vulture has multicoloured feathers and holds the *ankh*-sign at its feet. In the third register, the sacred falcon (centrifugally oriented) rests on a *heb*-bowl. In the fourth register figure two squatted mummiform gods (centrifugally oriented). The first is snake-headed and grasps the *ankh*-sign, while the second is human-headed wearing a yellow scarf. A short label refers to the *'Lord of dread'*. In the fifth register, two mummiform gods are squatted on the *pet*-sign. The first is cat-headed and grasps the *ankh*-sign, while the second is baboon-headed. A short label refers to the *'Lord of dread'*.

Below the *heb*-bowl figures the third register of the floorboard. A standing goddess with an *ankh*-sign pending from her raised arms praises two enthroned mummiform goddesses grasping *was*-signs and inverted *shen*-rings. A burning candle and a libation stand are depicted at their feet. A star shines over the standing goddess.

Footboard

The footboard is painted uniformly red.

Inscriptions

Bands of inscriptions bordered by multicoloured block-friezes run along the upper edge, from the headboard to the footboard (Inscriptions 1 and 2). The texts are outlined in red on a yellow background, with motifs painted in green, blue and red. Both the inscriptions face the headboard.

The great care taken in the rendering of each sign and in the use of colour is noteworthy, especially in the depiction of the *udjat*-eyes (Gardiner D10), the *akh*-bird (Gardiner G25), the *bee*-sign (Gardiner L2) and the sacred barques (Gardiner P3 and its variants).

In the final part of Inscription 1 the name of a former owner was erased and the name of Ankhefekhonsu was outlined in red.

Inscription 1

dd mdw in R^c-[hr-ꜥhty-tm], nb tꜣwy, Íwnwy, ntr ʕ h^c m wís[.f], wbn.f htp[.f], hpr ꜥhty [?]. Wsír, nb nhh, hnty Ímntt, Wnn-nfr, hkꜥ ꜥnh[w], nsw-bit, hkꜥ dt, di.s[n] htpw hꜥ m kꜥw, hꜥ m ꜥpdw, hꜥ m sntr, hꜥ m šs mnht, hꜥ m ht-nb[t] nfr[t] wꜥb[t], hꜥ m ht-nb[t] nfr[t] ndm[t] [n] Wsír ꜥnh.f[.n-] hns, w mꜥ-hrw

Words to be spoken by Re-[Harakhty-Atum], the lord of the Two Lands, the Heliopolitan, the great god who appears in [his] sacred barque, he rises and sets, Khopri[?] of the two eyes, [and by] Osiris, the lord of eternity, foremost of the West, Unnefer, ruler of the living, king of Upper and Lower Egypt, ruler of everlastingness, that they may give offerings, a thousand of oxen, a thousand of fowl, a thousand of frankincense, a thousand of alabaster [vessels] and clothing, a thousand of all things good and pure, a thousand of all things good and sweet [for] the Osiris Ankhefe[en]khonsu, justified.

Inscription 2

dd mdw in R^c- hr-ꜥhty-tm, nb tꜣwy, Íwnwy, ntr ʕ, h^c [m wís.f, wbn.f] m[?] htp[.f], hpr. shd.f tꜣwy [m] ꜥhty Wsír nb nhh, hnty Ímntt, ntr ʕ, nb ꜥbdw, Wn[n]-nfr, hkꜥ ꜥnh[w], nsw bit, hkꜥ dt, di.s[n] htp, di.f hꜥ m kꜥw, hꜥ m ꜥpdw, hꜥ m sntr, hꜥ m šs mnht, hꜥ m ht-nb[t] nfr[t] [n] [Wš]ír

Words to be spoken by Re-Harakhty-Atum, the lord of the Two Lands, the Heliopolitan, the great god who appears [in the/[his] barque, he rises], and he sets, Khopri, he illumines the Two Lands [N.B. written as two eyes (?)], [and by] Osiris, the lord of eternity, the foremost of the West, the great god, lord of Abydos, (and by) Unnefer, ruler of the living, king of Upper and Lower Egypt, ruler of everlastingness, that they [read: he] may give offerings, that he may give a thousand of oxen,

a thousand of fowl, a thousand of frankincense, a thousand of alabaster [vessels] and clothing, a thousand of all good things [for] [the Osiris].

The other texts (Inscriptions 3–9) are written in columns bordered by black lines. These texts are outlined in red and coloured green, blue and red. The left side displays 4 inscriptions (Inscriptions 3–6). All the inscriptions are oriented facing the headboard.

Inscription 3

(col. 1) *imꜣhy hr Wsir nb dwꜣt, nb [---]*

(col. 2) *imꜣhy hr ꜣst, wr[t], mwt ntr, irt Rꜥ, hnwt pr-nfr*

(col. 1) *The venerable one before Osiris, lord of the Duat. Lord of...*

(col. 2) *The venerable one before Isis, the great, the divine mother, the eye of Re, the mistress of the House of Embalming.*

Inscription 4

(col. 1) *imꜣhy [hr ---] Imntyw [---]*

(col. 2) *imꜣhy [hr ---]*

(col. 1) *The venerable one [before ---] the Westerners [---].*

(col. 2) *The venerable one [before ---].*

Inscription 5

(col. 1) *imꜣhy [hr ntr ꜣꜣ] nb dwꜣt šꜣꜣ[t] pri*

(col. 2) *imꜣhy [hr] ꜣst, wr[t], mwt ntr, irt Rꜥ, nbt*

(col. 1) *The venerable one [before the great god], lord of the mysterious Duat, who goes forth.*

(col. 2) *The venerable one [before] Isis, the great, the mother of the god, the eye of Re, the lady of.*

Inscription 6

(col. 1) *imꜣhy [hr ---] nb dwꜣt šꜣꜣ[t], pri*

(col. 2) *imꜣhy [hr ---] nbt pr-nfr di.s [hꜣp?]*

(col. 1) *The venerable one [before ---] lord of the mysterious Duat, who goes forth.*

(col. 2) *The venerable one [before ---] lady of the House of Embalming. That she may give (offerings).*

The right side displays 3 inscriptions (Inscriptions 7–9). All the inscriptions face the headboard except Inscription 8, which faces the footboard.

Inscription 7

(col. 1) *dd mdw in Wsir nb [Imnt ---]*

(col. 2) *dd mdw in 3st wr[t] [--- pr-nfr dī.s htpw]*

(col. 1) *Words to be spoken by Osiris, lord of [the West ---].*

(col. 2) *Words to be spoken by Isis, the great one, [---] the House of Embalming. That she may give offerings.*

Inscription 8

dd mdw in [Wsir], nb dw3t š3[t], pri m 3bdw

Words to be spoken by [Osiris] lord of the mysterious Duat, who goes forth from Abydos.

Inscription 9

(col. 1) *dd mdw i[n] Wsir, nb dw3t š3[t], hnty [Imnt]*

(col. 2) *[dd mdw in] 3st, wr[t], mwt ntr, irt R, nbt pr-nfr*

(col. 1) *[Words to be spoken by] Osiris, lord of the mysterious Duat, foremost of [the West].*

(col. 2) *[Words to be spoken by] Isis, the great one, the divine mother, the eye of Re, the lady of the House of Embalming*

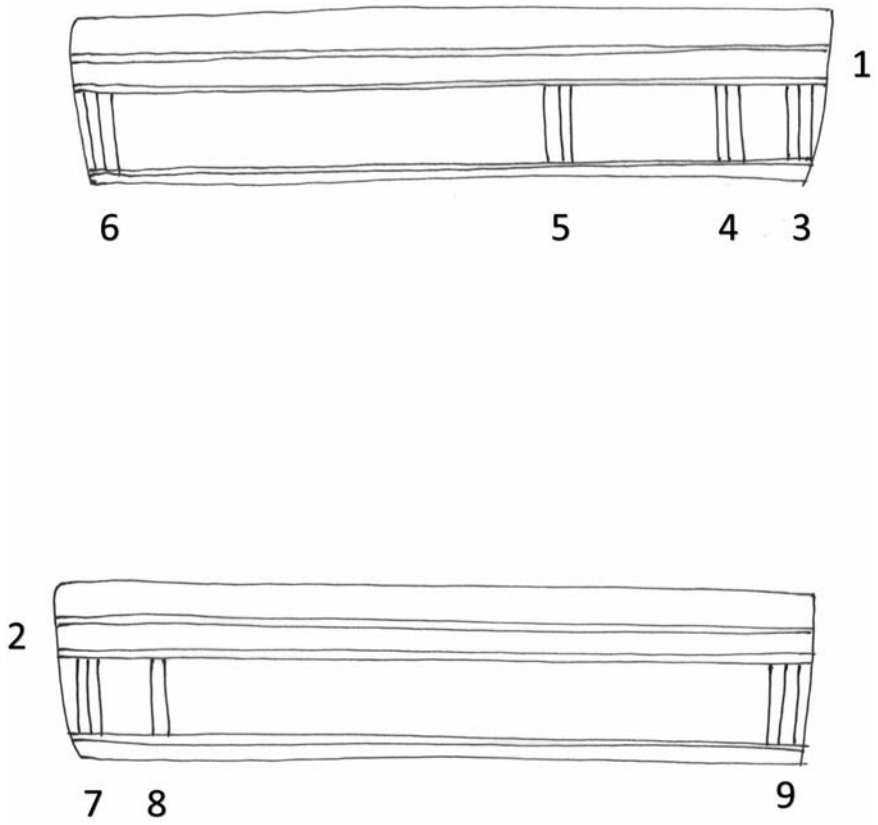
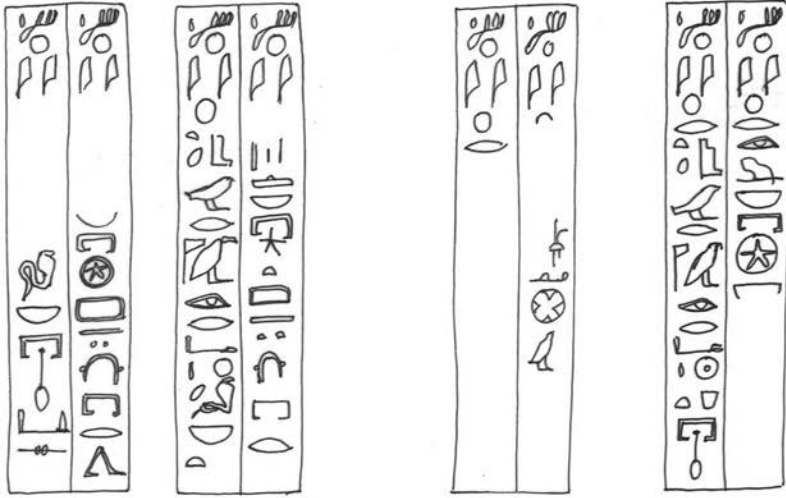

FIGURE 151 Outer case (A.60). Inscriptions

1

2

FIGURE 152 Outer case (A.60). Inscriptions 1-2



6 5 4 3

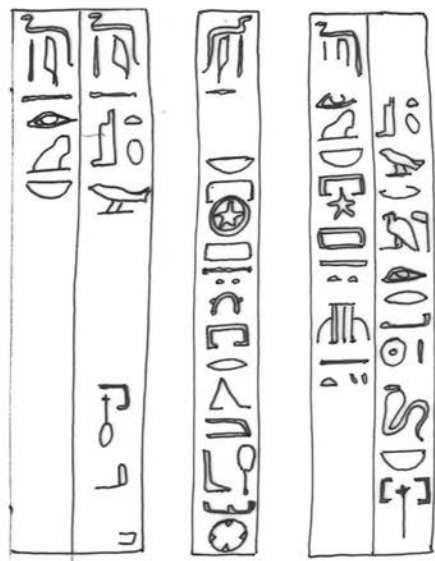

7 8 9

FIGURE 153 Outer case (A.60). Inscriptions 3-9



FIGURE 154
Outer case (A.60). Left side

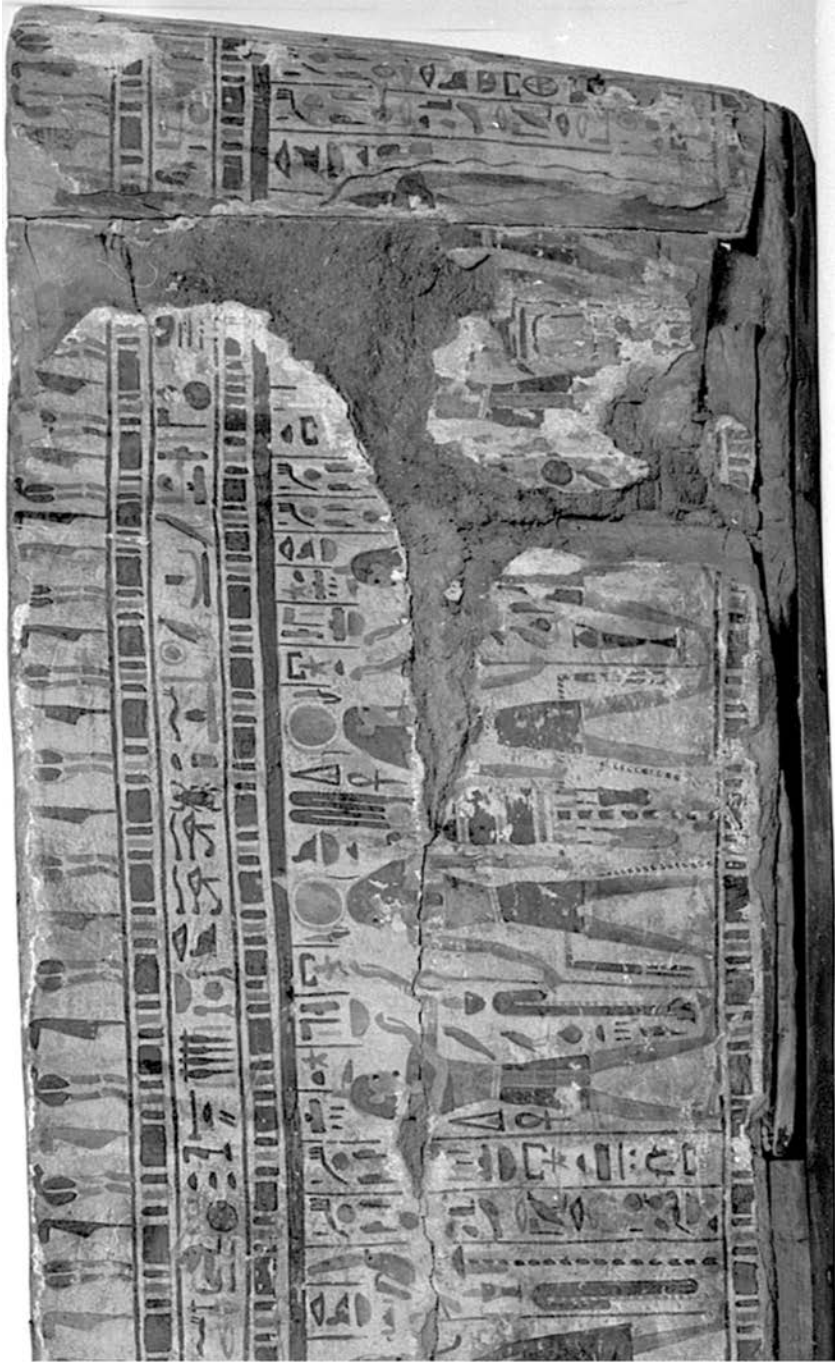

FIGURE 155 Outer case (A.6o). Left side, upper section

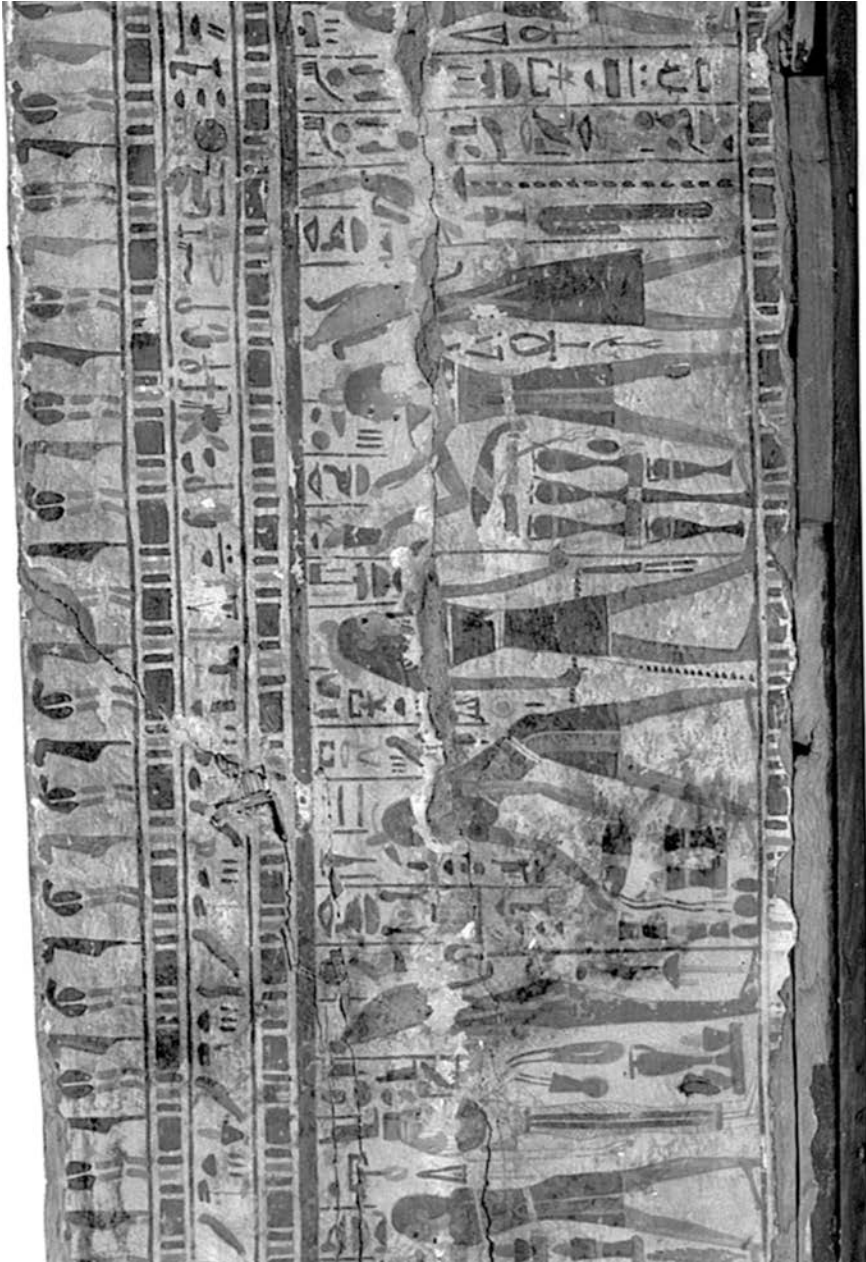

FIGURE 156 Outer case (A.6o). Left side, middle section

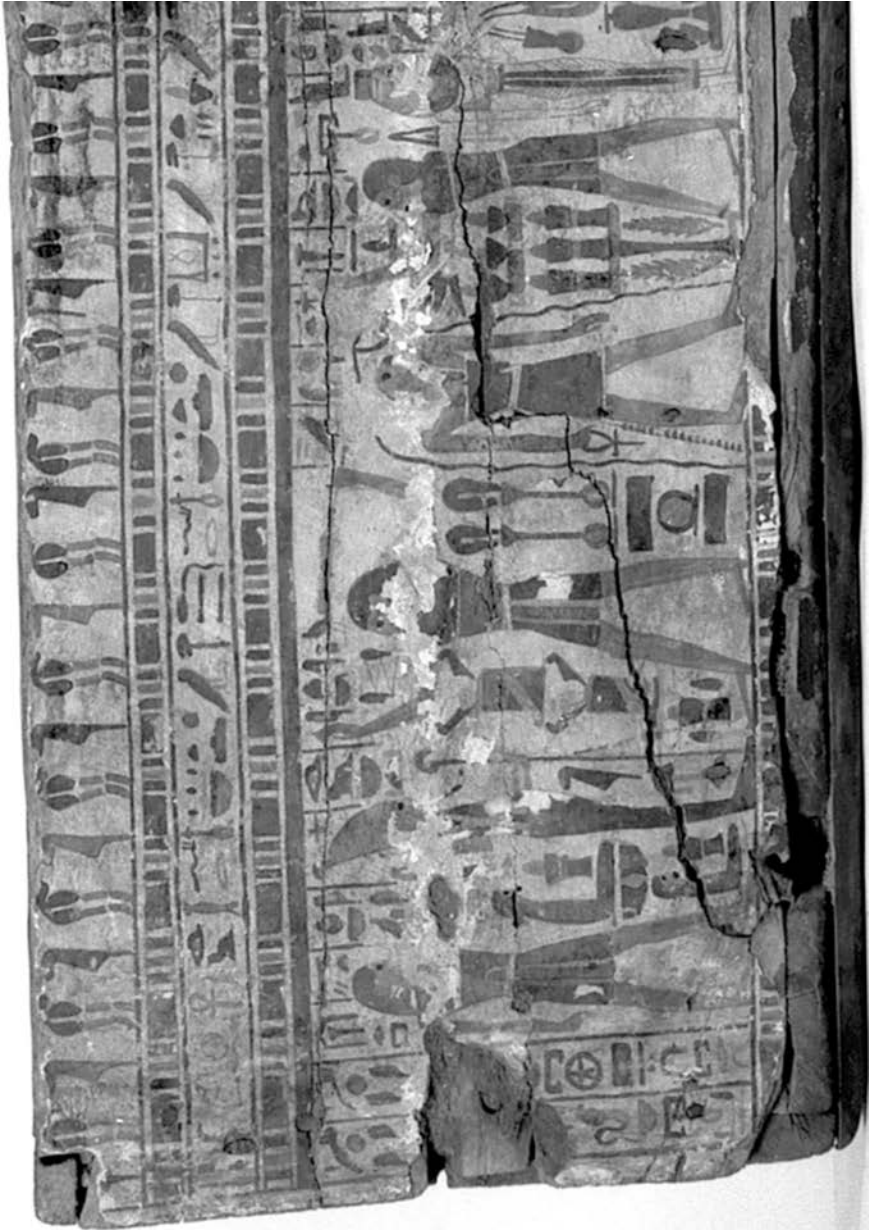

FIGURE 157 Outer case (A.60). Left side, lower section

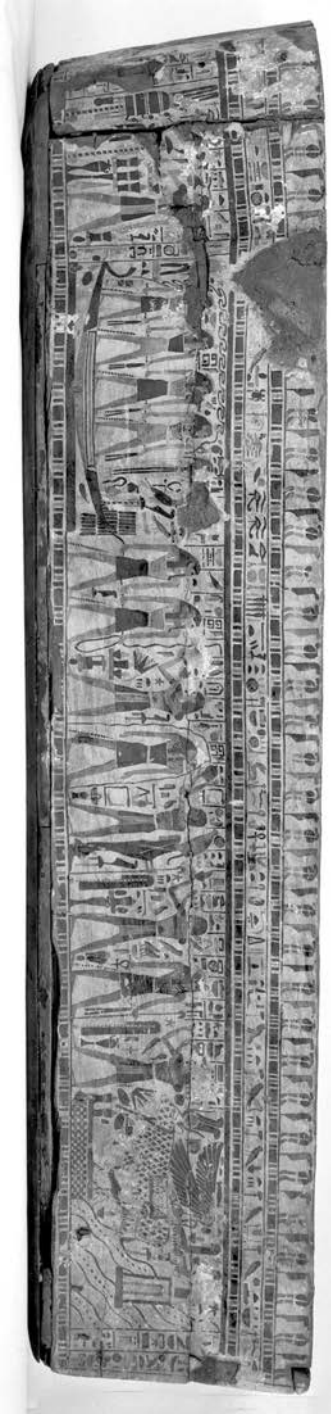

FIGURE 158
Outer case (A.60). Right side



FIGURE 159 Outer case (A.60). Right side, upper section

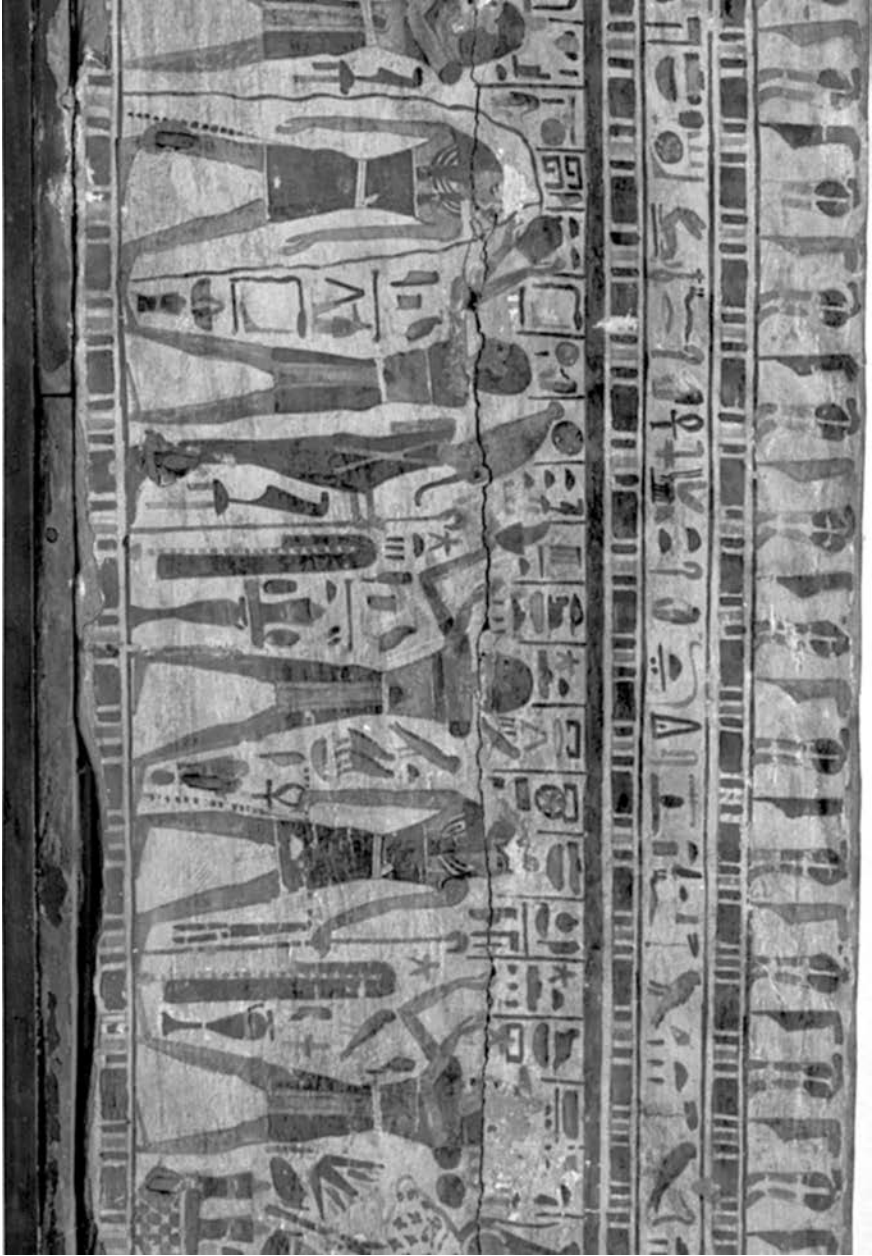

FIGURE 160 Outer case (A.60). Right side, middle section



FIGURE 161 Outer case (A.6o). Right side, lower section



FIGURE 162 Outer case (A.60). Interior decoration (headboard)



FIGURE 163
Outer case (A.60). Interior decoration



FIGURE 164
Outer case (A.60). Interior decoration (left side)

16. Inner Lid

Museum inventory number: 8526

Length: 178 cm; Width (max): 43 cm

Wood, plaster, paint and varnish.

Decorated with multicoloured paintwork.

The reverse side of the object is undecorated.

The hands are carved in wood and attached to the lid. The earrings and the breasts are moulded in plaster.

The painted decoration faded away around the mouth and on the chin. Several cracks are detected on the lower section and on the footboard, but the decoration is relatively well preserved.

Iconography

Headboard

A multicoloured headband decorated with geometrical patterns and floral motifs adorns the tripartite wig (black). A bunch of lotus flowers hangs from the crown of the head (Fig. 170). The face is roughly carved and painted in yellow with the contour of the eyes and eyebrows traced in black. The pupils (black) are painted against a white background. A red line is traced above the eye to suggest the eye-lid. The lips are outlined in red.

The decoration of the earrings has faded away.

The lappets of the wig are adorned with binding bands displaying geometrical motifs bounded by block-friezes.

Upper Section

The breasts feature rosettes to suggest the nipples (Fig. 170). The hands are open and crossed over the chest. The arms display red lines suggesting linen stripes. The forearms are crossed over the collar, displaying bracelets. Most of them are decorated with geometrical patterns (multicoloured) but four are composed of small *udjat*-eyes. The elbows are decorated with multicoloured lotus flowers.

The area comprised between the lappets of the wig presents a short collar displaying six transversal bands decorated with floral and geometrical motifs.

The large floral collar displays five bands decorated with a fairly diversified sample of patterns: geometrical motifs (3rd, 5th band), mandrake flowers (4th

band), persea-tree buds (2nd), lotus flowers intertwined with cornflowers and buds (1st). The clasps of the collar are falcon-headed (only partially depicted).

On the chest, lies a pectoral featuring a winged scarab (black) holding up a solar disk. The pectoral hangs from a necklace hidden under the short collar.

Central Panel

The central panel displays three registers (Figs. 171–172). The edges of the tableau are bordered by longitudinal inscriptions (Inscriptions 1–2) and transversal bands partially inscribed (Inscriptions 5–6).

The first register shows a symmetrical composition with a pectoral at the centre featuring a winged scarab (black) holding up a solar disk flanked by *udjat*-eyes. The pectoral hangs from a necklace hidden under the large floral collar. These motifs are flanked by centrifugal blocks showing the enthroned mummiform Osiris protected by a winged *djed*-pillar. Osiris wears the *hedjet*-crown and grasps the royal scepters. The *djed*-pillar is adorned with the solar disk resting on ram's horns. The composition is completed with centripetal blocks featuring a winged cobra wearing the *dšrt*-crown. The cobra hangs down from the upper corner of the tableau, outstretching its wings towards Osiris. The *udjat*-eye is depicted between its wings. Bunches of grapes and other offerings are piled up on a reed mat positioned at the feet of the enthroned god.

The second register is bounded by a large *pet*-sign (blue). Below, figures a winged goddess squatted on a lotus flower, outstretching her wings towards the sides. She wears a tight beaded dress and the modium bearing the monogram of Neith. Over her arms figure winged coiled cobras. *Udjat*-eyes flank the head of the goddess.

The third register features a very unusual composition with a large lotus flanked by centrifugal blocks featuring frogs spitting out a flow of water which is drunk by the *ba*-bird (centripetally oriented), who raises her hands to contain it. Piled offerings rest on reed mats behind the *ba*-bird.

Lower Section

This section is arranged in three longitudinal partitions (Figs. 173–174). Each partition is divided by transversal bands partially inscribed (Inscriptions 5–14). Two longitudinal bands of text run down the edges from the elbows to the footboard (Inscriptions 1–2).

The central partition presents four registers featuring symmetrical centripetal compositions. Elaborate friezes with geometrical and floral motifs divide the registers.

In the first register the *Ta-wer*-totem is crowned with the double-feathered solar headdress. This nuclear motif is flanked by winged cobras wearing *hedjet*-

crowns. They hang from the upper corner of the vignette. Piled offerings are depicted in the lower part of the scene. In the second register the *sekhem*-scepter is flanked by winged cobras wearing the sun disk. In the third register the *djed*-pillar is decorated with the double-feathered solar headdress. Winged cobras wearing the sun disk flank the composition hanging from the upper corner of the vignette. The fourth register displays the winged scarab holding up the solar disk flanked by cobras.

The lateral partitions display four registers. Each scene depicts a shrine. The ceiling is supported by a double column and is decorated with a double frieze composed of *iaret*-cobras and geometric patterns. Inside each shrine a deity is depicted. Note that the headdresses of these deities overlap the ceiling of the shrines.

In the first register, the deceased gives a libation vessel and burning incense (right side) or an ointment vessel (left side) to the enthroned Osiris. She wears a white festive garment and an ointment cone. Osiris is seated on a *hwt*-throne that rests on a *heb*-bowl. The god is red-skinned, has a curled beard, grasps the royal scepters and wears the *hedjet*-crown.

In the second register a mummiform ibis-headed god stands before the sacred falcon. The avian form of Ptah-Sokar wears the *atef*-crown with the solar disk and rests on a sacred standard with a feather at his feet. The winged *udjat*-eye is depicted behind him.

The third register presents the sacred ram wearing the double-feathered solar headdress on his horns. The deity rests on a divine standard with a feather at its feet. Two *nefer*-signs and the *udjat*-eye are depicted on its back, resting on a *heb*-bowl. A lettuce vase and several offerings are depicted below.

In the fourth register, the four Sons of Horus are squatted on *heb*-bowls. On the left side, figure Hapy (baboon-headed god), and Duamutef (jackal-headed god). On the right side, figure Imseti (human-headed), and Qebehsenuf (falcon-headed).

Footboard

The footboard follows the same tripartite organization observed on the lower section (Fig. 175). The edges are bounded by inscriptions (Inscriptions 1–2; Inscriptions 15–16).

The central partition is inscribed with two texts (Inscription 3–4).

The lateral partitions are badly damaged but reversed vignettes showing mourning goddesses can be detected.

Inscriptions

The lid displays two longitudinal inscriptions running down the edges from the elbows to the footboard (Inscriptions 1–2). The texts are written horizontally and not vertically. The hieroglyphs are outlined in red against a yellow background with motifs painted in blue, green and red. Calligraphy is cursive.

Inscription 1

dd [mdw] in Gb, r-p^ct ntrw, ʒh [pw] n s:ʒ hr pwy ms-n ʒst, iw^c pwy wr n nbw nhh, di.sn, h: [---] t, hnk^t, kʒw, ʒpdw, ht-nb[t] nfr[t] ndm[t], h: m sntr, šs [mnht], h: m ht-nb[t] nfr[t] w^cb[t].

Words to be spoken by Geb, prince of the gods, this akh of his son, this Horus who was born from Isis, this great heir of the Lords of eternity, so that they may give a thousand of [---], bread and beer, oxen and fowl, everything good and sweet, a thousand of frankincense grains, alabaster [vessels] and clothing, a thousand of all things good and pure.

Inscription 2

dd [mdw i]n Nwt, wrt, ms[t] ntrw, irt R:, hkʒ[t] idbwy, ʒh n s:ʒ hr [pw]y m[s-n] ʒst, iw^c [pwy] mn^h n Wnn-nfr, di.sn prt-hrw t, hnk^t, kʒw, ʒpdw, ht-nb[t] nfr[t] w^cb[t], ht-nb[t] nfr[t] ndm[t], n^h ntrw im.s

[Words] to be spoken by Nut, [---] the great one, who gave birth to the gods, the eye of Re, the ruler of the Two Banks, akh of his [sic, read: her] son, this Horus who was born by Isis, [this] beneficent heir of Unnefer, so that they may give an invocation offering consisting of bread and beer, oxen and fowl, everything good and pure, everything good and sweet on which the gods live.

The central partition of the footboard is inscribed with four columns of text (Inscriptions 3–4). The texts are centripetally oriented. The hieroglyphs are outlined in red and painted in blue, green and red. The lower part of the columns is badly damaged.

Inscription 3

(col. 1) *dd* mdw in Wsir nb[t pr] [Space left blank for the name] mʒ-hrw (col. 2) h: mwt[.i] [Nwt ps.š.t] dn^hwy.t hr.i ---]

(col. 1) *Words to be spoken by the Osiris, the mistress of the house, [Space left blank for the name], justified* (col. 2) *‘Oh [my] mother, [Nut, may you spread out] your wings [over me] ---’.*

Inscription 4

(col. 1) *dd mdw in [Nt ---], di[?]* (col. 2) *wnn[.i[?] mi ---]*

(col. 1) *Words to be spoken by Neith, [--- and let]* (col. 2) *me be such as [---].*

Transversal inscriptions divide the lower section of the lid in several registers (Inscriptions 5–14). All of them present variations of the same text. The first eight texts are arranged in shorter bands (Inscriptions 5–12), while the last four bands are fully extended along the vignettes (Inscriptions 15–16). The hieroglyphs are transversally arranged and calligraphy is cursive.

Inscriptions 5–6

imꜣhy ḥr Wsir

The venerable one before Osiris.

Inscriptions 7–8

imꜣhy ḥr skr

The venerable one before Sokar.

Inscriptions 9–10

imꜣhy ḥr bꜣ

The venerable one before the Ba.

Inscriptions 11–12 [no text preserved]

imꜣhy ḥr ḥpy

The venerable one before Hapy.

Inscription 13

imꜣhy ḥr ꜣst, wrt, mwt nṯr, irt [R^c], ḥmwt pr-nfr

The venerable one before Isis, the great one, the divine mother, the eye of [Re], mistress of the House of Embalming.

Inscription 14

imꜣhy ḥr Nbt-ḥwt snt ntr, sꜣt [---]

The venerable one before Nephthys, the god's sister, daughter [---].

Inscription 15

[in]k Nbt-ḥwt [snt] ntr, irt Rꜥ, ḥnwt [pr[?]]---- dꜣs ḥtp] dꜣꜣw

[I] am Nephthys, [the sister] of the god, the eye of Re, the mistress of the [House of[?] ---, that she may give[?] offerings and] provisions.

Inscription 16

[in]k ꜣst [---] irt Rꜥ, ḥnwt [pr---- dꜣs ---] ḥt nb[t] [---]

[I] am Isis, [--- the eye] of Re, the mistress of [the House of -- that she may give ---] everything [---].

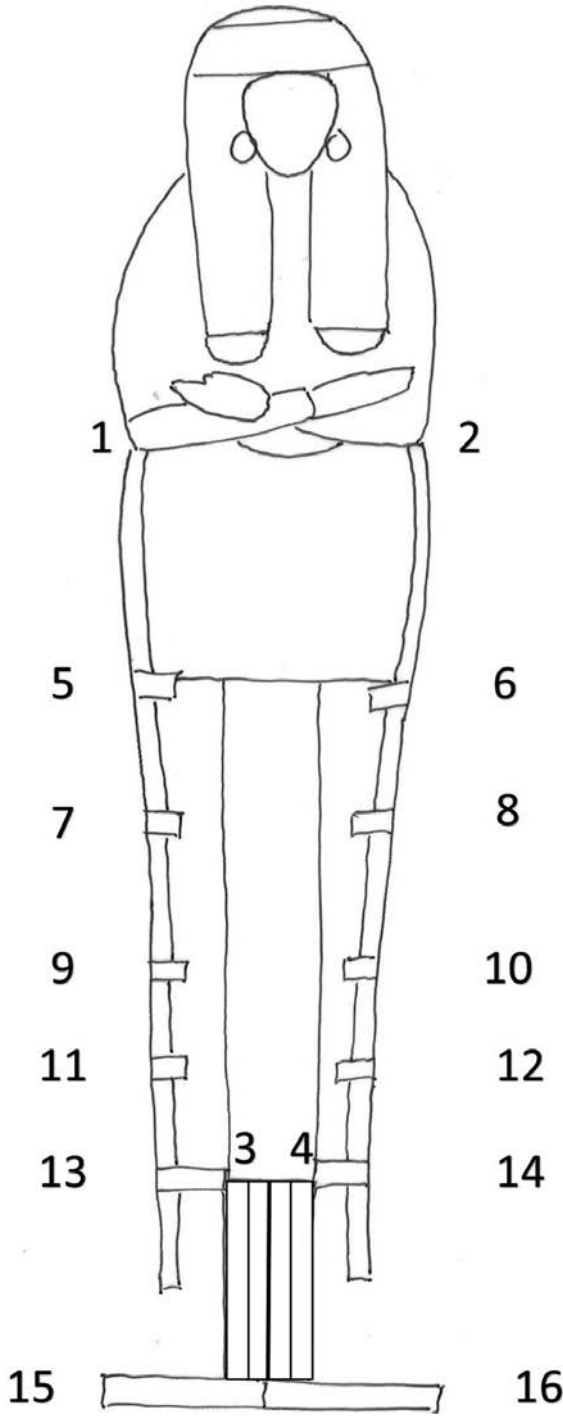

FIGURE 165
Inner lid (A.60). Inscriptions



FIGURE 166 Inner lid (A.6o). Inscriptions 1-2

3

4

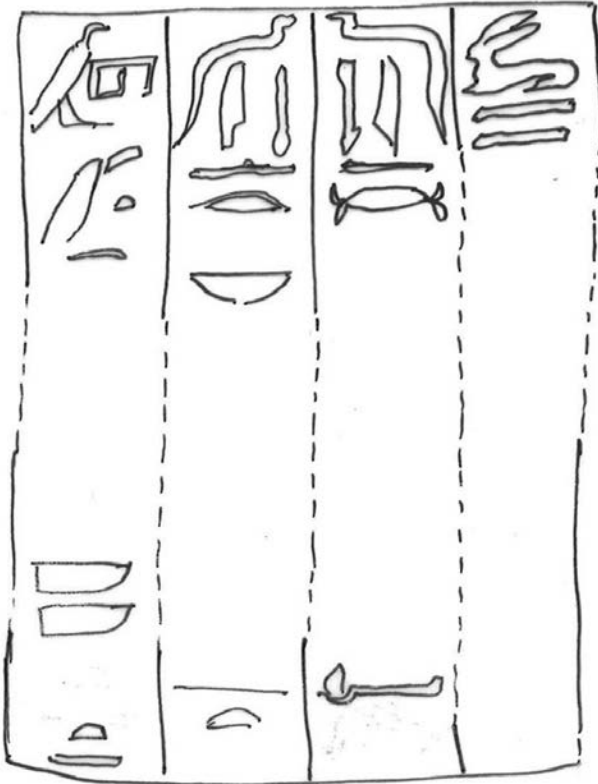

FIGURE 167 Inner lid (A.60). Inscriptions 3-4

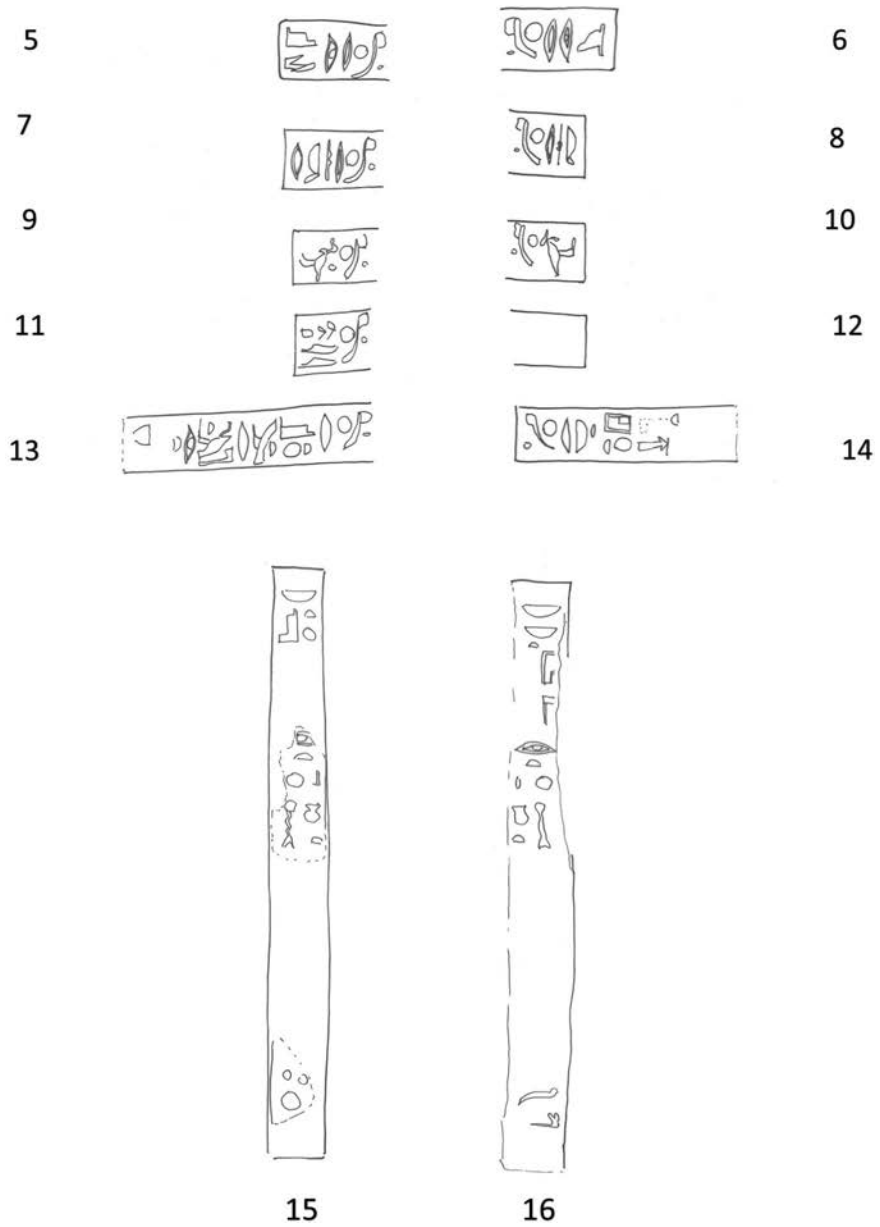

FIGURE 168 Inner lid (A.60). Inscriptions 5-16



FIGURE 169
Inner lid (A.60)



FIGURE 170 Inner lid (A.60). Headboard and upper section



FIGURE 171 Inner lid (A.60). Central panel



FIGURE 172 Inner lid (A.60). Central panel (drawing)



FIGURE 173
Inner lid
(A.60). Lower
section

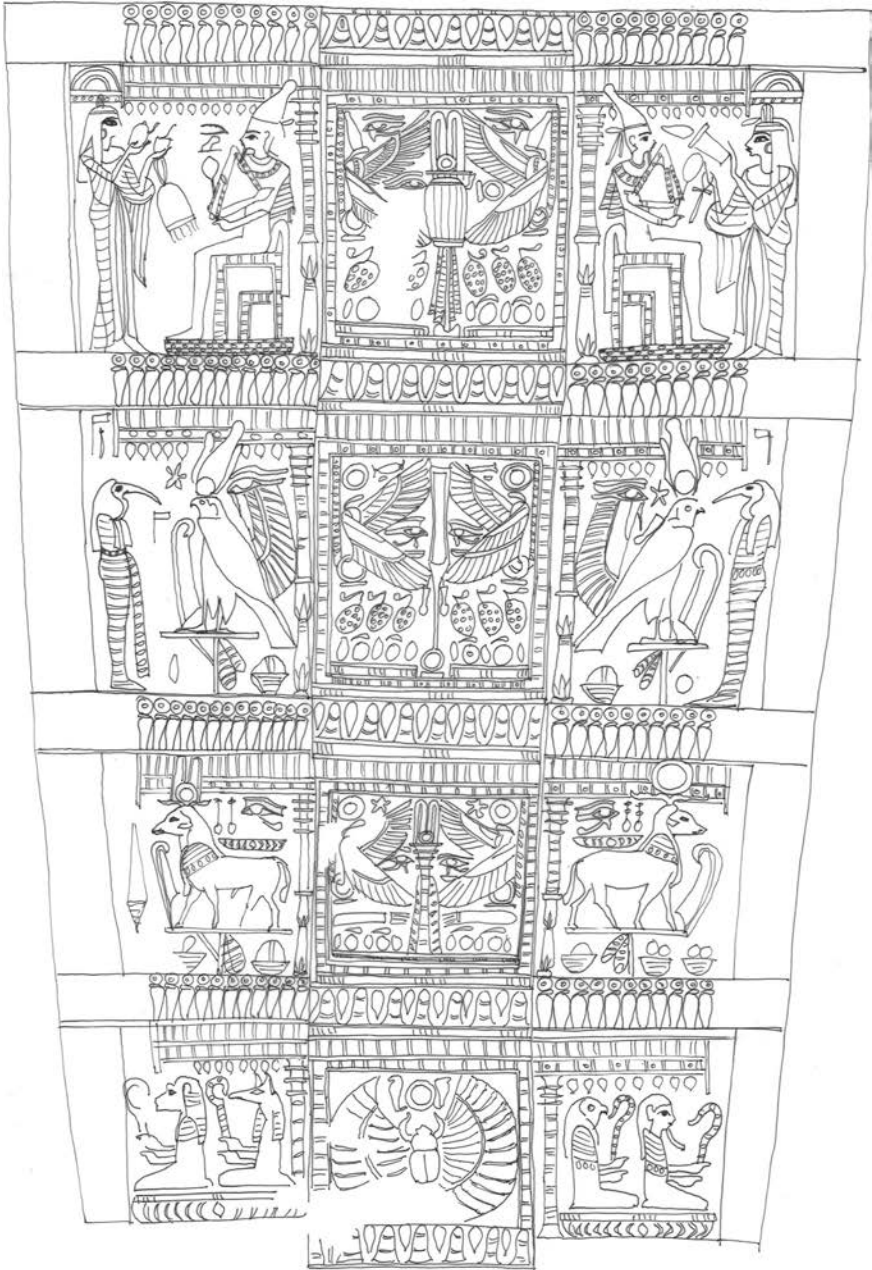

FIGURE 174 Inner lid (A.60). Lower section (drawing)



FIGURE 175 Inner lid (A.60). Footboard

17. Inner Case

Museum inventory number: 8526

Length: 178 cm; Width (max): 43 cm; Depth: 28 cm

Wood, plaster, paint and varnish.

Decorated with multicoloured paintwork.

On the interior, the sides are red and only the floorboard presents figurative decoration.

The exterior decoration is preserved in good condition. The headboard shows two longitudinal cracks. The painted decoration has faded away in this area. The footboard was lost. In modern times, it was restored by adding a new wooden plank.¹

Iconography (Exterior)

Both sides are decorated with friezes, inscriptions and vignettes. These motifs are discontinued on the headboard.

The upper edge is decorated with a frieze of alternating cobras (multi-coloured) and feathers (green). Below, runs a block-frieze.

The vignettes are bounded by columns of hieroglyphic texts (Inscriptions 1–14).

The lower edge is decorated with a thick horizontal band (black).

Headboard

The headboard is composed of a tripartite panel.

The *Vignette 1* (centre) is badly damaged, but a symmetrical composition can be detected (Fig. 178). The *tjet*-sign is outlined in red and blue. Two poles of the West flank the central motif, forming a centripetal composition.

The *Vignette 2* (left side) and *Vignette 3* (right side) are symmetrical, displaying the avian form of Ptah-Sokar resting on a divine standard under a vaulted shrine. The avian god wears the *atef*-crown and the *menat*-conterpoise (only on the right side). He has a feather at his feet. A winged *udjat*-eye is depicted behind him, with the pending cobra wearing the *hedjet*-crown (only on the left

¹ This advice is recorded by G. Botti in the handwritten entry of his Manuscript Catalogue of the Egyptian Museum of Florence.

side). A single column of hieroglyphs is written in front of the avian god, bearing the name 'Sokary', with offerings at his feet.

Left Side

The upper section is decorated with two vignettes (*Vignettes 4–5*) forming a single scene depicting the god Thoth before the *Ta-wer*-totem (Fig. 180).

The *Vignette 4* depicts the ibis-headed god identified as 'Lord of Ma'at' standing under a vaulted shrine facing the footboard and raising the right arm. The *imi-wt*-totem stands at his feet.

The *Vignette 5* shows a symmetrical composition with the *Ta-wer*-totem rising from the horizon. The totem is flanked by winged sacred cobras hanging down from the upper corner of the vignette. The name of 'Neith' is depicted in front of them and the *shen*-ring pends from their necks. The cobra on the left side wears the *dšrt*-crown and protects the *udjat*-eye, while that on the right side wears the *hedjet*-crown and protects the *shen*-ring. Piled offerings are shown below (cf. *Vignette 7* from A.20).

The lower section is composed of four vignettes (*Vignettes 6–9*). Although divided by four columns of text, the first two vignettes (*Vignettes 6–7*) form a single scene depicting the deceased before the solar barque.

The *Vignette 6* shows the deceased standing under a vaulted pavilion. She wears a festive garment and the *usekh*-collar (Fig. 181). Her head is adorned with an unguent cone. She holds a vessel with incense and a libation vessel pouring water over a libation stand.

The *Vignette 7* is divided in two registers by a thick black line suggesting the *pet*-sign (Fig. 181). On the upper part figures the solar barque carrying the winged scarab. Above the stern figures the title 'The great god', while a neat rests on the prow. In the lower register the head of the sacred falcon figures upside down rising from the *pet*-sign. Rays of light shine upon a mummiform god laying on the ground. Two mummiform gods (falcon-headed on the left and baboon-headed on the right) stand beside the head and feet of the recumbent god, while the vulture (left) and the cobra (right) are depicted over him.

The *Vignette 8* displays three mummiform gods standing on a coiled serpent under a vaulted ceiling (Fig. 181). The central ram-headed mummiform deity is facing the headboard. He is flanked by a lion-headed god (left) and a jackal-headed deity (right).

The *Vignette 9* presents two different scenes (Fig. 182). The first scene depicts the deceased standing before the sycamore tree. She wears a white festive garment and is adorned with an unguent cone. She raises her arms to drink the water offered by the sycamore deity (cf. *ba*-birds depicted on the central panel

of the lid). The goddess is standing among the leaves, clad in a tight green dress and crowned with the monogram of Ma'at (cf. *Vignette 7*, fifth scene on the case from A.22). Behind the tree, the sacred cow emerges from the Theban Mountain, standing on a platform (facing the headboard). The goddess is adorned with the Hathoric headdress and the sistrum. A ritual vessel figures at her feet. A winged cobra with a long coiled tail outstretches its wings towards the goddess, embracing the *udjat*-eye. Further left, the tomb is depicted on the cliffs of the desert, with the name of 'Osiris' inscribed over its door and on the pyramidal superstructure.

Right Side

The upper section is decorated with two vignettes (*Vignettes 10–11*) forming a single scene depicting the god Thoth before the enthroned Osiris.

The *Vignette 10* shows the ibis-headed god Thoth, identified as *Lord of Ma'at*, standing under a vaulted shrine, and raising his arm while grasping the *ankh*-sign (Fig. 185). The *imi-wt*-totem stands at his feet (cf. *Vignette 4*).

The *Vignette 11* depicts the enthroned mummiform god Osiris. He has curled beard, and wears the *hedjet*-crown and a beaded mantle on the shoulders (Fig. 185). A winged goddess figures behind Osiris with the modium on her head. She wears a tight beaded dress (red). The *hwt*-throne rests on a reed mat and a *heb*-bowl. The *imi-wt*-totem and lettuce-vases stand at the feet of Osiris. Above, figure the winged *udjat*-eye with a pending serpent wearing the *ankh*-sign on its neck. Another *udjat*-eye and the label '*great god*' are depicted in the remaining spaces.

The lower section is composed of four vignettes (*Vignettes 12–15*). The *Vignettes 12* and *13* recall the composition of *Vignettes 6* and *7*.

In the *Vignette 12* the deceased stands under a vaulted pavilion, wearing a festive garment and the *usekh*-collar. She raises a reed mat with offerings. A libation stands at her feet (Fig. 185).

The *Vignette 13* is divided in two registers by a thick black line suggesting the *pet*-sign (Fig. 185). On the upper part figures the solar barque carrying the winged scarab. Above the prow figures the word '*Duat*'. In the lower register the head of the sacred falcon figures upside down rising from the *pet*-sign. Rays of light shine upon a mummiform god laying on the ground. Two mummiform gods (falcon-headed on the left and baboon-headed on the right) stand beside the head and feet of the recumbent figure of the god. A sacred vulture (left) and a sacred cobra (right) are depicted above the god (cf. *Vignette 7*).

The *Vignette 14* features three mummiform gods standing on a coiled serpent under a vaulted shrine (Fig. 185). The central ram-headed mummiform deity

faces the headboard. He is flanked by a jackal-headed deity on the left and a lion-headed god on the right (cfr. *Vignette 8*).

The *Vignette 15* displays the judgment scene (Fig. 186). The deceased raises her arms, wearing a white festive garment, the *usekh*-collar and an unguent cone with a lotus bud. The pole of the West stands behind the deceased. The heart of the deceased (left tray) is being weighed on the human-headed scale against the monogram of Ma'at (right tray). Below the arms of the scale figure the jackal-headed god Anubis (left) and a squatted (mummiform?) figure. Before the scale stands the falcon-headed Horus, dark-skinned and wearing the double-crown. Before the god is couched the Great Devourer, identified by the name 'Shayt'. Horus raises his right arm towards the mummiform Osiris. He is seated on a *hwt*-throne, wearing the *hedjet*-crown, and grasping the royal scepters. The *imi-wt*-totem stands at his feet, while a goddess (green skinned) clad in a tight beaded dress figures at his back. Short labels refer to 'Horus, defender of his father Osiris', 'Osiris, lord of the Duat' and 'Nephthys'.

Footboard

The footboard remained undecorated (Fig. 178).

Iconography (Interior)

The thicknesses are stepped and painted yellow. The mortars (four at each side) are positioned in the transition from the lower to the higher edge.

The sides are painted uniformly red.

Floorboard

The decoration of the floorboard shows a large goddess painted against red background (Figs. 187–302).² The goddess is standing on the *nebu*-sign and faces left with her arms along her flanks. She wears a double-feathered solar headdress and the 'crown of justification'. The long beaded dress (white) is decorated with red dots. Bracelets adorn her arms and ankles. The pole of the West is depicted beside her legs, on her right side.

² Nevertheless, following the physical evidences we can conclude that even the lower part of the floorboard was decorated. In fact traces of yellow paint can be detected in this area.

Inscriptions

The hieroglyphs are outlined in red against a yellow background with motifs coloured green, blue, yellow and red. These texts are written in columns bordered by vertical lines (black). Calligraphy tends to be cursive.

The left side displays 7 inscriptions (Inscriptions 1–7). Inscriptions 1, 3, 6 and 7 face the headboard, while Inscriptions 2, 4 and 5 face the footboard. The fourteenth column shows a large depiction of the pole of the West.

Inscription 1

[*dd mdw in Pth-skry*]-*Wsr nb [štyt?]*

[*Words to be spoken by Ptah-Sokar*], *Osiris lord of the [Shetyt-shrine?]*.

Inscription 2

(col. 1) *dd mdw in dhwtj, nb mdw-ntr, sš mꜣt* (col. 2) *n Psdt-ꜣ[t]: ‘nḥ Rꜥ, mt štyw, rꜥ-nb’[?]*

(col. 1) *Words to be spoken by Thoth, lord of the divine words, scribe of Ma'at*
(col. 2) *of the Great Ennead: ‘may Re live, may the turtle die every day[?]’.*

Inscription 3

dd mdw in Wsr, nb ꜣbdw, ḥnty Ímntt nfrt, ntr ꜣ

Words to be spoken by Osiris, Lord of Abydos, foremost of the beautiful West, the great god.

Inscription 4

Wsr nbt pr, šmꜣyt n Ímn, ꜣḥ pw

The Osiris, the mistress of the house, the chantress of Amun, this akh.

Inscription 5

(col. 1) *ind ḥr.k Rꜥ-tm-ḥpꜣy, it ntrw, ir dt.f*, (col. 2) *ḳmꜣ [ḥꜣw].f, sꜣ-sw r ntrw nb*,
(col. 3) *w di-sw m pt, r ntr[y] bꜣ.f, wbn* (col. 4) *ḥtp rꜥ-nb, ntj[?]ist[f] ḳmꜣ ḥm.sn[?]*

(col. 1) *Hail to you Re-Atum-Khepri, father of the gods, who made his own body*,
(col. 2) *who created his own flesh, who made himself greater than all the gods*,
(col. 3) *who put himself in the sky so that his ba is divine*, (col. 4) *Who rises and sets every day, [] who creates their[?] divine images.*

Inscription 6

(col. 1) *dd mdw in nbw nhh, h3tyw n dt, Psdt*-(col. 2)³[t] *nh [ntyw] m[sic]/hr t3, htpw, nty m db3t*

(col. 1) *Words to be spoken by the lords of eternity, the foremost of everlastingness, the Great* (col. 2) *Ennead: may live those who are in/on the earth, and may rest those who are in the sarcophagus.*

Inscription 7

(col. 1) *dd mdw in hft-hr-nb.s, hnwt hsy.w* (col. 2) *di.s htpw df3w*

(col. 1) *Words to be spoken by Khefthernebes, the mistress of the praised/favoured ones,* (col. 2) *that she may give offerings and provisions.*

The right side displays 7 inscriptions (Inscriptions 8–14). Inscriptions 8, 10, 13 and 14 face the headboard, while Inscriptions 9, 11 and 12 face the footboard. Noteworthy is a fourteenth column displayed next to the footboard, but instead of an inscription it shows a large depiction of the pole of the West (cf. outer case from A.56).

Inscription 8

dd mdw in Pth-skry-[Wsir] [nb štyt[?]

Words to be spoken by Ptah-Sokary-[Osiris], [lord of the Shetyt-shrine].

Inscription 9

(col. 1) *dd mdw in dhwtj, nb mdw-ntr, sš m3t* (col. 2) *n Psdt-3t: 'nh R3, mt štyw, r-nb'*

(col. 1) *Words to be spoken by Thoth, lord of the divine words, scribe of Ma'at* (col. 2) *of the great Ennead: 'Re lives, the turtle dies every day'.*

Inscription 10

dd mdw in Nwt, wrt, ms[t] ntrw, hk3t idbwy

Words to be spoken by Nut, the great one, who gave birth to the gods, the ruler of the Two Banks.

Inscription 11

Wsr nbt pr, šmꜣyt n Īmn, ȝḥ pwy

The Osiris, the mistress of the house, the chantress of Amun, this akh.

Inscription 12

(col. 1) *ind ḥr-k, Rꜥ-tm-ḥpri, it ntrw, ir* (col. 2) *dt,f, [ḥmꜣ] ḥꜣw,f, sꜣ-sw r ntrw* (col. 3) *nb, di-sw m pt, r ntr[y] bꜣ,f, wb* (col. 4) *n ḥtp, rꜥ-nb, dl.k mꜣꜥ-ḥrw mi [?---]*

(col. 1) *Hail to you Re-Atum-Khepri, father of the gods, who made* (col. 2) *his own body, and his own flesh, who made himself greater than all the gods,* (col. 3) *who put himself in the sky, so that his ba is divine* (col. 4), *who rises and sets every day. That you may grant justification as [...].*

Inscription 13

(col. 1) *dd mdw in nbw nhḥ, ḥꜣtyw n dt, Psdt* (col. 2) *-ꜣ[t], nb ḥrt-ntr, ḥtp n[t]y[w] m dbꜣt.*

(col. 1) *Words to be spoken by the lords of eternity, the foremost of everlastingness, the great* (col. 2) *Ennead, Lord of the necropolis: ‘may rest those who are in the sarcophagus’.*

Inscription 14

Īnpw ury mhꜣt, ntr ꜣꜣ

Anubis, who belongs to the scale, the great god.

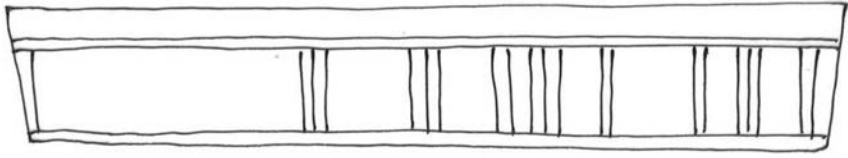

7 6 5 4 3 2 1

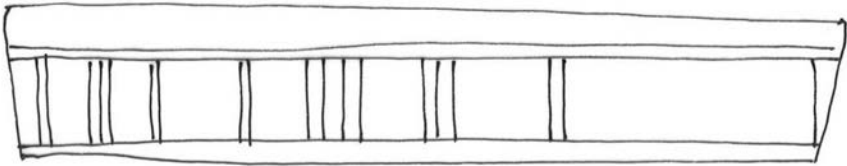

8 9 10 11 12 13 14

FIGURE 176 Inner case (A.60). Inscriptions

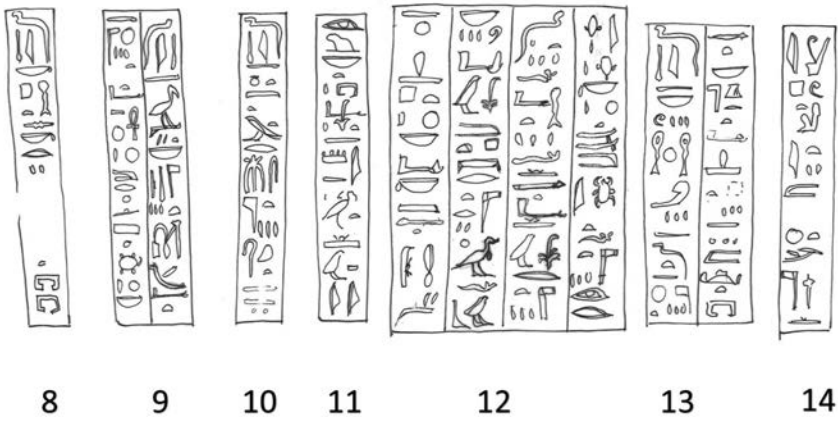
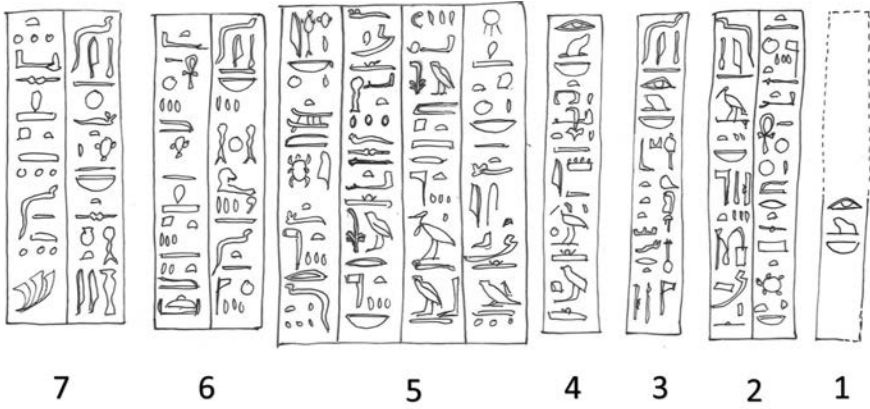

FIGURE 177 Inner case (A.60). Inscriptions 1-14



FIGURE 178
Inner case (A.60). Headboard (above),
footboard (below)



FIGURE 179
Inner case (A.60). Left side



FIGURE 180 Inner case (A.60). Left side, upper section



FIGURE 181 Inner case (A.60). Left side, middle section



FIGURE 182 Inner case (A.60). Left side, lower section



FIGURE 183
Inner case (A.60). Right side



FIGURE 184 Inner case (A.60). Right side, upper section



FIGURE 185 Inner case (A.60). Right side, middle section



FIGURE 186 Inner case (A.60). Right side, lower section



FIGURE 187
Inner case (A.60). Interior decoration

18. Mummy-Cover

Museum inventory number: 8521

Length: 167 cm; Width: 39 cm

Wood, plaster, paint and varnish.

Decorated with multicoloured paintwork.

The reverse side of the object is undecorated.

The ears, the earrings, the lappets of the wig and the hands are moulded in plaster.

The object is preserved in relatively good condition. The painted decoration faded away in some points and several cracks can be detected, mainly on the right side of the upper section and around the hands.

The lower edge collapsed and was restored in modern times by adding a piece of wood.¹

Iconography

Headboard

A multicoloured headband decorated with geometrical patterns adorns the tripartite wig (black). A bunch of a lotus flowers hangs over the forehead (Fig. 192).

The face is roughly carved and painted in yellow. The contour of the eyes and eyebrows is traced in black. The pupils (black) are painted against a white background. A red line is traced above the eye to suggest the eye-lid. The lips are outlined in red.

The ears are moulded and the anatomical details are outlined in red. Oddly enough, a pair of round earrings are juxtaposed to the ears. They feature small rosettes.

The lappets of the wig are adorned with binding bands decorated with a beaded motif.

Upper Section

The breasts are painted, not moulded. They feature small rosettes to suggest the nipples (Fig. 192).

1 This advice is recorded by G. Botti in the entry of his Manuscript Catalogue of the Egyptian Museum of Florence. He confirms that the mummy-cover was restored in 1957, so we can conclude that even this piece was included among the objects restored between 1957 and 1958 and cited by Bosticco (see Bosticco 1958).

The hands are open, painted yellow and crossed over the chest. Against the usual practice, the hands are not carved in wood but entirely moulded in plaster. The arms are decorated with red lines suggesting linen stripes and each elbow features a large multicoloured lotus flower.

The forearms display bracelets showing geometrical patterns (multicoloured).

The area comprised between the lappets of the wig presents a short collar. The large floral collar displays three bands decorated with geometrical motifs (2nd and 3rd band) and persea-tree buds and lotus petals (1st band). The clasps of the collar feature a falcon head.

On the chest lies a winged scarab holding up a solar disk flanked by cobras.

Central Panel

The tableau displays two registers (Fig. 193). The first register shows a symmetrical composition. The nuclear block features a winged scarab holding up a solar disk. The scarab is depicted as a pectoral hanging from a necklace hidden under the floral collar. The centrifugal blocks include a mummiform Osiris squatting on a sacred standard. The god has a curled beard, grasps the royal scepters, and wears the *hedjet*-crown. Behind him, coiled cobras are depicted under the wings of the pectoral.

Centripetal blocks complete the composition, featuring a winged coiled cobra (identified as Neith) hanging from the upper corner of the composition. The cobra outstretches its wings towards the *udjat*-eye.

The second register displays a large winged goddess squatted on the *nebu*-sign (multicoloured) outstretching her wings towards both sides and grasping feathers. Under each wing figure a coiled cobra and the *udjat*-eye (centrifugally oriented).

Lower Section

This area is divided into two longitudinal partitions by a double column of hieroglyphs (Inscriptions 1–2). Each partition is divided into four registers by transversal bands of inscriptions (Inscriptions 3–10). Each vignette depicts a deity (centrifugally oriented) under a vaulted ceiling (Fig. 194).

In the first register a mummiform god is seated on a *hwt*-throne resting on a *heb*-bowl. The god has a curled beard, grasps the royal scepters, and wears the *hedjet*-crown and a beaded shirt. A lettuce vase stands at his feet. The winged *udjat*-eye with a pending cobra carrying the *ankh*-sign faces the enthroned god.

In the second register the avian form of Ptah-Sokar rests on a divine standard with a feather at his feet. The avian god wears the *atef*-crown and the *menat*-

counterpoise. The winged *udjat*-eye is depicted behind him and he is identified as ‘*Sokary*’.

The third register shows the avian manifestation of the deceased resting on a divine standard. The *ba*-bird has curled beard and wears a collar. His head is adorned with a feather. The winged *udjat*-eye is depicted behind him.

The fourth register is badly damaged, but remains of the *udjat*-eye have been preserved, showing that it was the main subject of the vignette.

Inscriptions

Two longitudinal inscriptions (Inscriptions 1–2) run down the centre of the lower section. The inscriptions are centripetally oriented. The hieroglyphs are outlined in red against a yellow background and some details are painted in black, green, red and blue. Some of the hieroglyphs used in these inscriptions are finely executed, such as the determinative of the barque (Gardiner P 3) and the sacred vulture (Gardiner G 14). The symmetrical display of the inscriptions creates interesting visual effects, such as the writing of the name of Osiris, where the eyes suggest a human face seen frontally.

Inscription 1

dd mdw in Wsir nbt-pr, šmꜣyt n İmn-Rꜥ, nsw ntrw, ʿnh-s-n-mwt: ‘hꜣy, mwt[.i] Nwt, psš.t dnḥwy[.t] m. [sic, read: ḥr]i, diw wnn[.i] mi iḥmw-sk, mi iḥmw-wrḏ [---]’

Words to be spoken by the Osiris, the mistress of the house, the chantress of Amun-Re, king of the gods, Ankhesenmut: ‘Oh, [my] mother Nut, spread out [your] wings over me and let [me] be as the Imperishable stars, as the Unweary stars [---].’

Inscription 2

dd mdw in Wsir, nbt pr, šmꜣyt n İmn-Rꜥ, nsw ntrw, ʿnh-s-n-mwt: ‘pr.t [sic, read: i] r pt, dꜣi.t [sic, read: i] biꜣ, [snsn].t [sic, read: i] m sbꜣw nw pt, ir.t[w] [n.i] ḥknw m wiꜣ [---]’

Words to be spoken by the Osiris, the mistress of the house, the chantress of Amun-Re, king of the gods, Ankhesenmut: ‘May I go forth to the sky, may I cross the firmament and may I mingle with the stars of heaven and may praise be made [to me] in the sacred barque of [---].’

Short transversal inscriptions divide the lower section in several registers (Inscriptions 3–10). All of them are centripetally oriented and present variations of the same text.

Inscriptions 3–4*imꜣḥ[y] ḥr Wsir ḥkꜣ ʿnḥw**The venerable one before Osiris, the ruler of the living.***Inscriptions 5–6***imꜣḥ[y] ḥr skr nṯr ʿꜣ**The venerable one before Sokar, the great god.***Inscriptions 7–8***imꜣḥ[y] ḥr bꜣ**The venerable one before the ba.***Inscriptions 9–10***imꜣḥ [ḥr] wdꜣt**The venerable one before the Udjat-eye.*

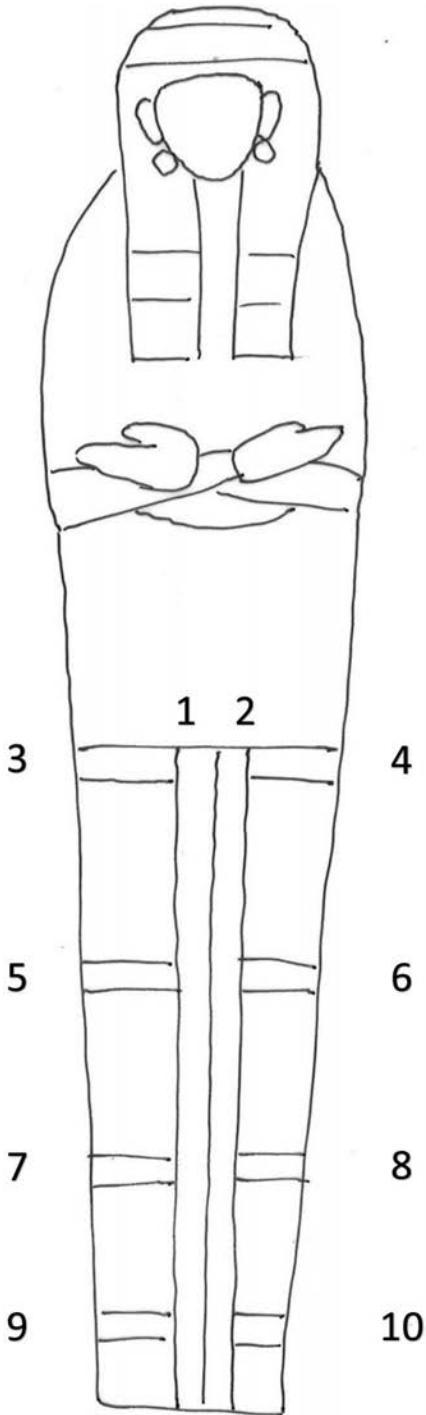

FIGURE 188
Mummy-cover (A.60). Inscriptions

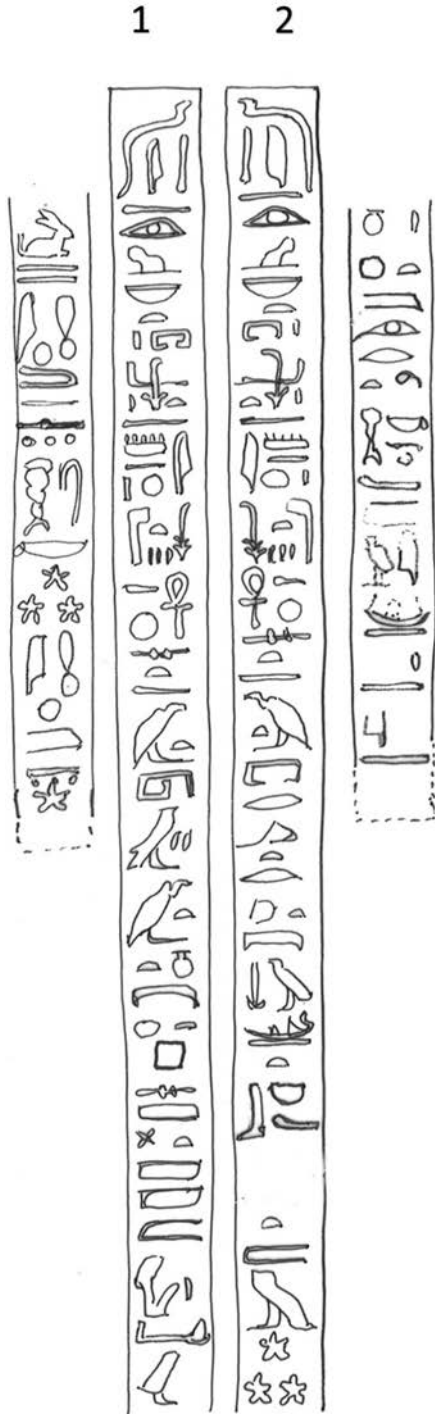

FIGURE 189
Mummy-cover (A.60). Inscriptions 1-2

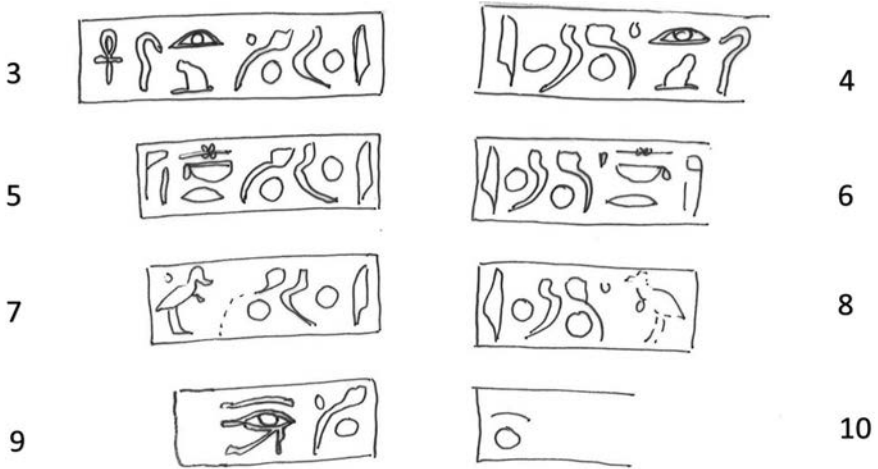

FIGURE 190 Mummy-cover (A.60). Inscriptions 3-10



FIGURE 191
Mummy-cover (A.60)

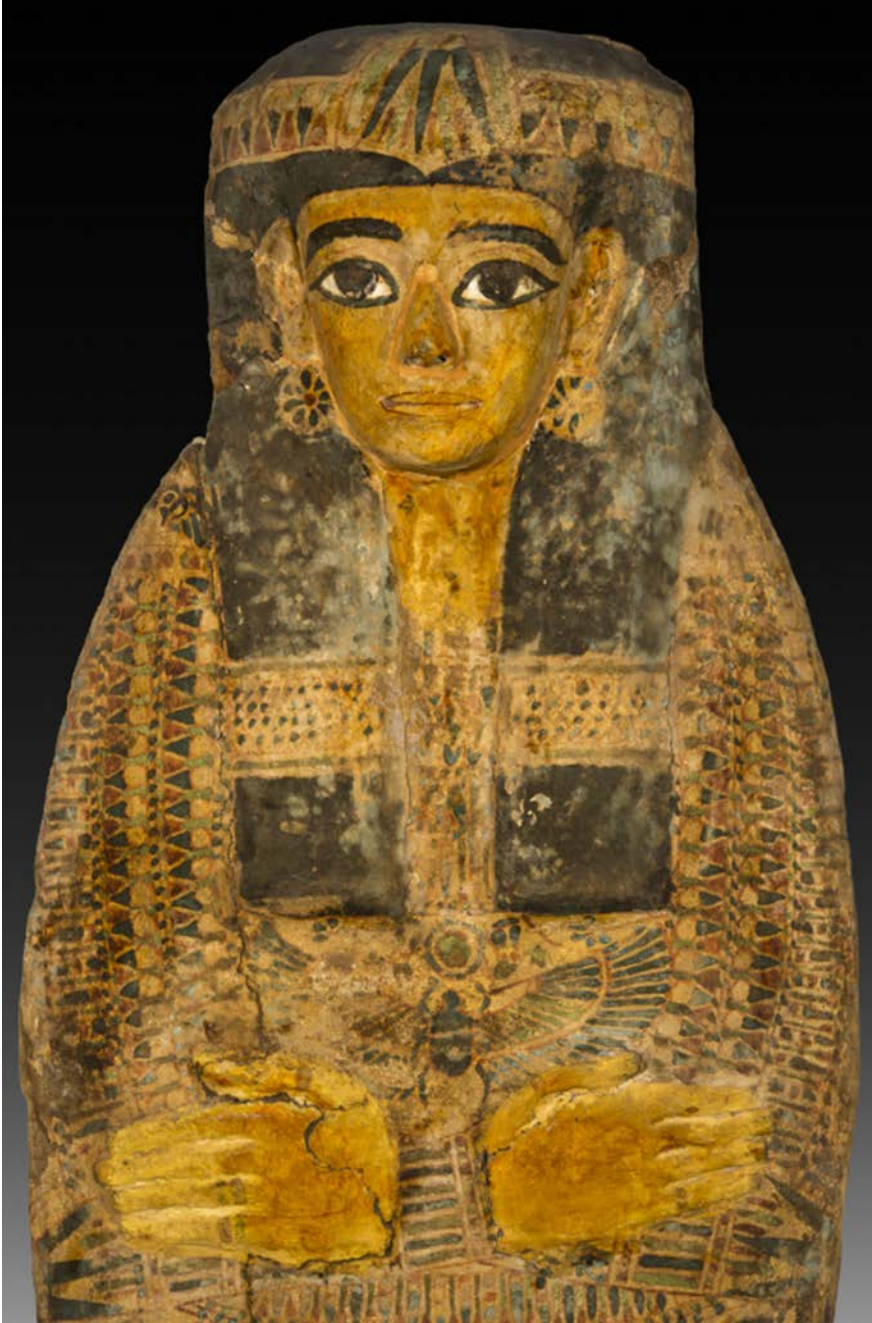

FIGURE 192 Mummy-cover (A.60). Headboard and upper section



FIGURE 193 Mummy-cover (A.6o). Central panel



FIGURE 194
Mummy-
cover (A.60).
Lower section

SECTION 2

Shabtis

Marianna Zarli



Introductory Notes

The collection of 92 *shabtis* from Bab el-Gasus received by the Egyptian Museum in Florence is composed of objects taken from different burial assemblages, usually in pairs. In this Catalogue, the statuettes from the same burial assemblage will be presented together, distinguished with the letters “a” and “b” with the respective Inventory number. The objects are listed following the alphabetical order of the name of their owners, according to the sign-list provided by the *Egyptian Grammar*.¹ The Catalogue number is followed by the transliterated name of the deceased, if known or legible, with transcription in brackets.

For each pair of *shabtis* we will provide:

- Concordances with the number of the List filled in at the Giza Museum before shipping² and with the List by Daressy, published in 1907.³
- Photographs of each object in frontal and back views. In exceptional cases the lateral view is also provided.
- Dimensions (height only).
- Raw material.
- Condition.
- Description.
- Information about the original composition of the burial assemblage.
- Inscriptions (including hieroglyphs and translation).
- Typology of the object.
- Location of other examples from the same burial assemblage.
- Publications in which the *shabti* appears.
- References.

The typology is taken from Schneider (1977).

1 Gardiner 1957, 27.

2 See the chapter about the shipping documents related to Lot v.

3 Daressy 1907, 4–14.

1. Shabtis of Isety (ꜥsty)

Inv. NN. 8594 and 8595

Cairo List: 12

Daressy List: A.66

Height: (a) 6,5 cm; (b) 6 cm

Raw Material: Pottery once painted blue

State of Preservation: The painted decoration is faded away, as well as the hieroglyphic inscription. In (b) there is a crack in the lower part and the statuette is damaged on the feet.

Description

Mummiform servant.

Face poorly modeled.

Tripartite wig. Arms crossed (?) over the chest.

Burial Assemblage

Two women with very similar names were buried in Bab el-Gasus: Iset (A.127) and Isety (A.66).

Daressy ascribes all the *shabtis* to the deceased from A.66.¹ Nevertheless two series of *shabtis* have been identified suggesting that each of these women had her own collection of statuettes.

The series represented by Louvre E 20230 carries the name Iset and it is to be ascribed to the burial assemblage A.127.²

Conversely the second, smaller, series can be ascribed to Isety, from the burial assemblage A.66. This Chantress of Amun was buried in a coffin set now kept in the Egyptian Museum in Cairo.³ The funerary equipment included a pair of red leather shoes, a pair of sandals, an Osiris shroud, a red serviette, mummy braces, a wax embalmer's plaque, two papyrus⁴ and a *shabti*-box. A *Book of the Dead* now in Chicago was probably enclosed in an Osiris figure.⁵

1 Daressy 1907, 15.

2 Aubert 1998, 48–49 n. 1.

3 Niwiński 1988, 122 n. 99. Outer coffin, inner coffin and mummy cover. Dating: late 21st Dynasty (mummy braces of King Psusennes II).

4 Book of the Amduat (S.R. 10239) and Magical Papyrus (CG 58001). See Aston 2009, 175 TG 739.

5 Aston 2009, 175 TG 739.

The shabtis in Florence (n. 8594–8595) could be ascribed to the last series. Indeed, although the hieroglyphic inscription is faded away, the little size of the statuettes and the characteristic feature of the arms raised to the chest, but not crossed, confirm the matching.

Inscription

Faded away.

Typology

4.3.1—Tc: Cl. VIII A1; W 16; H 16; I ?; B ?; Tp 7b (?).

Other examples of *shabtis* for Isety are found in Cairo Museum⁶ and Roanne.⁷

Bibliography

Unpublished.

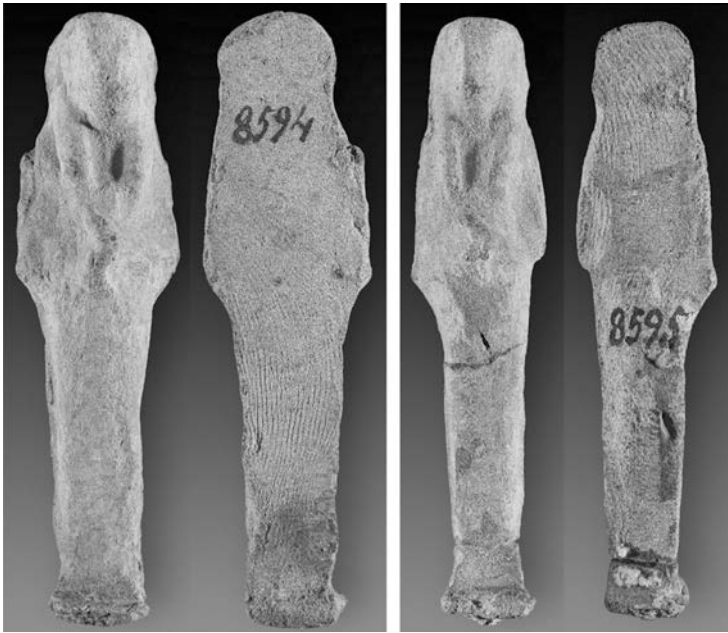

FIGURE 195 Shabtis of Isety

6 Newberry 1957, 288–289 CG. 48064–73. The examples from CG. 48064 to CG. 48068 are 7 cm high, while the examples from CG. 48069 to CG. 48073 have been pressed out of a smaller mold and measure 6 cm. The examples from Florence could be ascribed to this second group.

7 Gabolde 1990, 149 n. 134.

2. Shabtis of Isetemkhebi (*st-m-ḥ-bit*)

Inv. NN. 8542 and 8543

Cairo List: 4

Daressy List: A.126

Height: (a) 8,8 cm; (b) 9,5 cm

Raw Material: Light blue faience

State of Preservation: In (a) the glaze is damaged and the decoration is patchy.

The inscription is faded. The statuette was broken in the lower part and repaired. In (b) the glaze has disappeared almost entirely. The first part of the inscription and the vertical black lines are faded.

Description

Mummiform servant.

Face poorly modeled. The wig is painted black. Eyes and brows are summarily outlined. Ears modeled over the lappets of the tripartite wig. Arms crossed over the chest grasping the hoes.

Large basket on the back (painted black).

The iconographic details (hoes and basket) are outlined in black.

Inscription

Painted black. One column of hieroglyphs bounded by two vertical lines (black).

“The Osiris Isetemkhebi”.

Typology

(a) 4-3.1—Tc: Cl. VIII A2; W 17; H 1; I 5; B 12b; Tp 7a

(b) 4-3.1—Tc: Cl. VIII A2; W 17; H 1; I 5; B 12b; Tp 7c

Other examples of *shabtis* for Isetemkhebi are found in Basel,¹ Berlin,² Cairo,³ Clermont-Ferrand,⁴ Copenhagen,⁵ Cortona,⁶ Leiden,⁷ Lisbon,⁸ London,⁹ Madrid,¹⁰ Paris,¹¹ Roanne,¹² Stockholm,¹³ Uppsala,¹⁴ Warsaw¹⁵ and in private collections.¹⁶

Burial Assemblage

The coffins of Isetemkhebi, from the burial assemblage A.136, are kept in the Egyptian Museum in Cairo.¹⁷ On the objects from her burial assemblage we can read the titles of “Mistress of the house” and “Chantress of Amun-Re, king of the gods”. The funerary equipment of Isetemkhebi included an Osiris shroud, a necklace, a basalt scarab, a lead pectoral on the chest, a lead embalmer’s plaque, a funerary papyrus¹⁸ and a *shabti*-box.¹⁹

Two types of *shabtis* are attested for the deceased A.126: small mummiform and tall mummiform. The objects here described are examples of the first series (see N.Cat. 3 for the second series).

Bibliography

Unpublished.

-
- 1 Schlögl and Brodbeck 1990, 179 n. 111a.
 - 2 Roeder 1913, n. 11898.
 - 3 Newberry 1957, 64–66 CG. 47016–47030.
 - 4 Dautant et al. 2013, Table 1 n. 4.
 - 5 Mogensen 1918, n. 3957–3958.
 - 6 Botti 1955, 69 n. 116.
 - 7 Schneider 1977, n. 4.3.1. 1–2.
 - 8 Sociedade de Geografia de Lisboa, n. 2507-4 A and B. Araujo 2003, 595–596 n. 1–2. Museu Nacional de Arqueologia, E 102, E 401–402, E 460. Araujo 2003, 701–704 n. 1–4.
 - 9 Petrie 1935, n. 305. See http://www.britishmuseum.org/research/collection_online, EA 24814.
 - 10 <http://ceres.mcu.es>, n. 18266–67.
 - 11 Aubert 1998, n. 2 (Louvre E 22095).
 - 12 Gabolde 1990, 105 n. 86.
 - 13 <http://collections.smvk.se/carlotta-mhm>, NME 903 (overseer).
 - 14 Sandman 1931, 105 n. 29.
 - 15 Pomorska 1959, 121 n. 31.
 - 16 Janes 2002, 61–62.
 - 17 Niwiński 1988, 125–126 n. 114. Outer coffin, inner coffin and mummy cover, type 111a. Dating: middle/late XXI Dynasty.
 - 18 Niwiński 1989, 259 n. 18—S.R.IV. 555 (JE 95657—Book of the Amduat, type A.111.1a).
 - 19 Aston 2009, 187 TG 799.

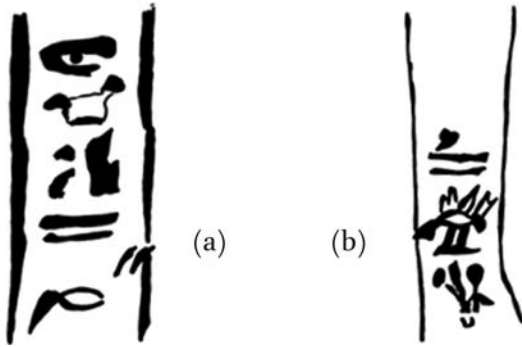

FIGURE 196 Shabtis of Isetemkhebi (Inscriptions)



FIGURE 197 Shabtis of Isetemkhebi

3. Shabtis of Isetemkhebi (*st-m-h-bit*)

Inv. NN. 8586 and 8587

Cairo List: 26

Daressy List: A.126

Height: 12,2 cm

Raw Material: Blue faience

State of Preservation: Good.

Description

Mummiform servant.

Features of the face finely modeled and outlined in black. The wig is painted black.

Ears modeled over the lappets of the tripartite wig (modeled and painted black). Short collar (three lines) depicted between the lappets.

Arms crossed over the chest grasping the hoes.

Basket on the back.

The iconographic details (hoes and basket) are outlined in black.

These are examples of the second series of *shabtis* belonging to the burial assemblage of Isetemkhebi—A.126 (see N.Cat. 2 for the first series).

Inscription

Painted black. One column of hieroglyphs, bounded by two vertical black lines. “The Osiris, mistress of the house, Isetemkhebi”.

Typology

4.3.1—Tc: Cl. VIII A1; W 17; H 8; I 5; B 12b; Tp 7a

Other examples of *shabtis* for Isetemkhebi are found in Amiens,¹ Basel,² Berlin,³ Brussels,⁴ Cairo,⁵ Clermont-Ferrand,⁶ Copenhagen,⁷ Cortona,⁸ Leiden,⁹ Lisbon,¹⁰ London,¹¹ Madrid,¹² Paris,¹³ Roanne,¹⁴ St. Gallen,¹⁵ Stockholm,¹⁶ Uppsala,¹⁷ Wien¹⁸ and in private collections.¹⁹

Bibliography

A. Pellegrini, *Bessarione VII* (1899–1900), p. 13 n. 64–65.

-
- 1 Dautant et al. 2013, Table 1 n. 26.
 - 2 Schlögl and Brodbeck 1990, 180 n. 11b.
 - 3 Roeder 1913, n. 11898.
 - 4 <http://carmentis.kmkg-mrah.be>, E 05423–24.
 - 5 Newberry 1957, 64–66 CG 47001–47015.
 - 6 Dautant et al. 2013, Table 1 n. 26.
 - 7 Mogensen 1918, n. 3984.
 - 8 Botti 1955, 69–70 n. 81.
 - 9 Schneider 1977, n. 4.3.1.3.
 - 10 Sociedade de Geografia de Lisboa, n. 2507-26 B. Araujo 2003, 597.
 - 11 http://www.britishmuseum.org/research/collection_online, EA 24815–16.
 - 12 <http://ceres.mcu.es>, n. 18310–11.
 - 13 Aubert 1998, n. 2 (photograph on the left—overseer). Louvre E 22096.
 - 14 Gabolde 1990, 107 n. 88.
 - 15 Schlögl and Brodbeck 1990, 179 n. 111.
 - 16 <http://collections.smvk.se/carlotta-mhm>, NME 905.
 - 17 Sandman 1931, 96 n. 4.
 - 18 Haslauer 1992, AS 8414.
 - 19 Janes 2002, 61–62 n. 30.

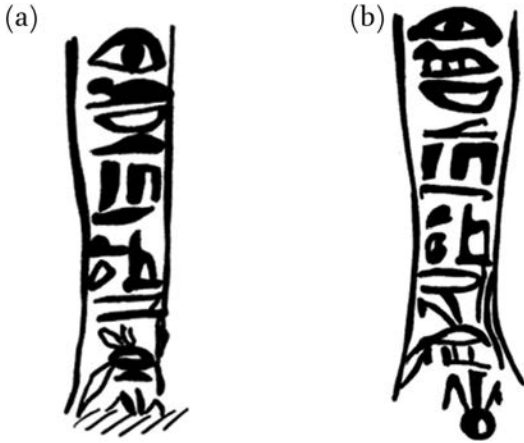

FIGURE 198 Shabtis of Isetemkhebi (Inscriptions)



FIGURE 199 Shabtis of Isetemkhebi

4. Shabtis of Amenhatpamesha (*Īmn-ḥꜣt-pꜣ-mšꜥ*)

Inv. NN: 8616 and 8617

Cairo List: 5

Daressy List: A.124 (?)

Height: 12 cm

Raw Material: Light blue faience

State of Preservation: Good. In (a) a break has been repaired in the lower part.

Description

Mummiform servant.

Face poorly shaped with eyes and brows summarily outlined in black. The wig is painted black.

Ears modeled over the lappets of the tripartite wig (modeled).

Arms crossed over the chest grasping the hoes.

In (a) there is a small basket, while in (b) the basket is missing.

The iconographic details (hoes and basket) are outlined in black.

Inscription

Painted black. One column of hieroglyphs.

(a) “The Osiris, divine father of Amun, Amenhatpamesha, justified”.

(b) “The Osiris, Amenhatpa[masha], justified”.

Typology

(a) 4. 3.1—Tc: Cl. VIII A1; W 17; H ?; I 5; B 13b; Tp 7b

(b) 4.3.1—Tc: Cl. VIII A1; W 17; H 8; I 5; B ?; Tp 7b

Other examples of *shabtis* for Amenhatpamesha are found in museums in Aix-les-Bains,¹ Amsterdam,² Assisi,³ Berlin,⁴ Brussels,⁵ Cairo,⁶ Copenhagen,⁷ Cor-

¹ Aubert 1988, 5 n. 276.

² Haarlem 1990, 108–109 Inv. 9049.

³ Rosati 1985, 62 n. 14b.

⁴ Roeder 1913, n. 11892–3.

⁵ <http://carmentis.kmkg-mrah.be>, E 05403 a–b.

⁶ Newberry 1957, 37–38 CG 46714–46732 and pp. 40–42 CG 46759–46767.

⁷ Mogensen 1918, n. 4006.

tona,⁸ Leiden,⁹ Lisbon,¹⁰ London,¹¹ Lyon,¹² Madrid,¹³ Oslo,¹⁴ Paris,¹⁵ Roanne,¹⁶ St. Gallen,¹⁷ Toulouse,¹⁸ and in private collections.¹⁹

Burial Assemblage

The coffin of Amenhatpamesha has not been identified, but the name Amenhat(pa)mesha is written on two funerary papyri kept in the Egyptian Museum in Cairo.²⁰ These two papyri have been associated with the coffin ensemble A.124 also kept in Cairo²¹ and show the titles of “Divine father of Amun, king of the gods” and “Divine father of Mut”. His *shabtis* usually carry the abbreviated version “Divine father of Amun” (a), although on some examples the title can be omitted. On some examples the writing of the name is abbreviated as Amenhatpa (b).

Bibliography

A. Pellegrini, *Bessarione VII* (1899–1900), p. 12 n. 56.

-
- 8 Botti 1955, 70–71 n. 117 and 108.
 9 Schneider 1977, n. 4.3.1. 10–11.
 10 Sociedade de Geografia de Lisboa, n. 2507-5 A and B. Araujo 2003, 598–599 n. 4–5.
 11 Petrie 1935, n. 275. http://www.britishmuseum.org/research/collection_online, EA 24887–88.
 12 Dautant et al. 2013, Table 1 n. 5.
 13 <http://ceres.mcu.es>, n. 18268–69.
 14 Naguib 1985, EM 8085.
 15 Louvre 22097.
 16 Gabolde 1990, 101–102 n. 82.
 17 Schlögl and Brodbeck 1990, 162 n. 97.
 18 Dautant et al. 2013, Table 1 n. 5.
 19 Janes 2002, 70–71 n. 34; Aubert 1998, n. 3.
 20 Niwiński 1989, p. 277 n. 67—S.R.VII. 10230 (Book of the Dead, type BD.III.1a) and p. 295 S.R.VII. 11495 (Book of the Amduat, type A.III.1a).
 21 Niwiński 1988, 127 n. 124. Outer coffin. Dating: late 21st Dynasty (mummy-linen of King Siamun, years 8 and 10; mummy-linen of King Amenemope and H.P. Pinudjem).

A vertical column of hieroglyphs, likely an inscription from a shabti. The characters are arranged in a single column and include various symbols such as birds, lotus flowers, and other standard hieroglyphic elements.

(a)

A vertical column of hieroglyphs, likely an inscription from a shabti. The characters are arranged in a single column and include various symbols such as birds, lotus flowers, and other standard hieroglyphic elements.

(b)

FIGURE 200 Shabtis of Amenhatpamesha
(Inscriptions)



FIGURE 201 Shabtis of Amenhatpamesha

5. Shabtis of Amenhotep (*Īmn-ḥtp*)

Inv. NN. 8548 and 8549

Cairo List: 10

Daressy List: A.39

Height: (a) 10,4 cm; (b) 10 cm

Raw Material: Light blue faience

State of Preservation: Good. In (a) there are chips on the arms.

Description

Mummiform servant.

Face poorly shaped with eyes and brows summarily outlined in black. Tripartite wig with modeled lappets and *seshed*-headband.

Arms crossed over the chest grasping the hoes.

Basket on the back.

Inscription and iconographic details (headband, hoes and basket) are painted black.

Inscription

Painted black. One column of hieroglyphs bounded within three black lines (one horizontal on the top and two vertical on the sides).

(a) “The Osiris, *wab*-priest and scribe, Amenhotep, justified”.

(b) “The Osiris, *wab*-priest of Amun and scribe, Amenhotep”.

Typology

(a) 4.3.1—Tc: Cl. VIII A2; W 19; H 8; I 5; B 12b; Tp 7c

(b) 4.3.1—Tc: Cl. VIII A2; W 19; H ?; I 5; B 12b; Tp 7c

Other examples of *shabtis* for Amenhatpamesha are found in museums in Basel,¹ Berlin,² Brussels,³ Cairo,⁴ Copenhagen,⁵ Erevan,⁶ Leiden,⁷ Lisbon,⁸ Lon-

1 Schlögl and Brodbeck 1990, 178 n. 110a.

2 Roeder 1913, n. 11947.

3 <http://carmentis.kmkg-mrah.be>, E 05447 a–b.

4 Newberry 1957, pp. 32–34 CG. 46644–46691, p. 39 CG 46734–46738 and pp. 42–43 CG 46768–46772.

5 Mogensen 1918, n. 3977–3978.

6 Berlev and Hodjash 1998, n. 28.

7 Schneider 1977, n. 4.3.1. 12–13.

8 Sociedade de Geografia de Lisboa, n. 2507-10 A and B. Araujo 2003, 600–601 n. 6–7.

don,⁹ Lyon,¹⁰ Madrid,¹¹ Oslo,¹² Paris,¹³ Roanne,¹⁴ St. Gallen,¹⁵ Warsaw,¹⁶ Wien¹⁷ and in private collections.¹⁸

Burial Assemblage

The coffin set of the “Divine father of Amun-Re”, “*wab*-priest of Mut” and “Scribe of the army recruits” Amenhotep is kept in the National Museum of Natural History in Washington.¹⁹ His funerary papyri are in Cairo Museum²⁰ together with a *shabti*-box. The burial assemblage included an Osiris shroud, a bronze embalmer’s plaque, an inlaid hawk-shaped pectoral and a heart scarab.²¹

Bibliography

Unpublished.

-
- 9 Petrie 1935, UC 277. http://www.britishmuseum.org/research/collection_online, EA 24865–66.
- 10 Dautant et al. 2013, Table 1 n. 10.
- 11 <http://ceres.mcu.es>, n. 18278–79.
- 12 Naguib 1985, EM 8088 and EM 2309.
- 13 Louvre, E 22103 and E 22118.
- 14 Gabolde 1990, 103–104 n. 85.
- 15 Schlögl and Brodbeck 1990, 178 n. 110.
- 16 Pomorska 1959, 123 n. 36.
- 17 Haslauer 1992, AS 6196.
- 18 Janes 2002, 73–75 n. 36a and 36b (overseer); Aubert 1998, n. 5 (overseer).
- 19 Niwiński 1988, 179 n. 426. Inner coffin and mummy-cover, type IIC of the cover. Dating: late 21st Dynasty.
- 20 Niwiński 1989, p. 256 n. 9—S.R.IV. 543 (JE 95646—Book of the Dead, type BD.II.1) and p. 257 n. 12—S.R.IV.546 (JE 95648, Book of the Amduat, type A.III.2a).
- 21 Aston 2009, 170 TG 712.

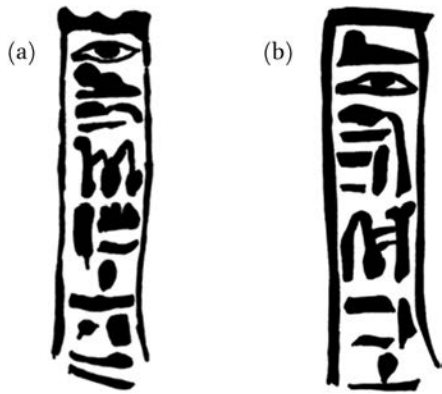

FIGURE 202 Shabtis of Amenhotep
(Inscriptions)



FIGURE 203 Shabtis of Amenhotep

6. Shabtis of Ankhefenmut (*ḥnḥ.f-n-Mwt*)

Inv. NN. 8536 and 8537

Cairo List: 13

Daressy List: A.140

Height: (a) 12,6 cm; (b) 12,5 cm

Raw Material: Clay pottery painted red.

State of Preservation: Good. Breaks have been repaired in the lower part.

Description

Mummiform servant.

Features of the face slightly modeled. Eyes painted black.

Ears modeled over the lappets of the tripartite wig (modeled).

Arms crossed over the chest grasping the hoes (slightly modeled).

Basket on the back (painted black).

The rear side is roughly moulded.

Inscription

Moulded. One column of hieroglyphs.

“That may shine the Osiris, divine father of Amun and Mut, Ankhefenmut, justified”.

Typology

4.5.1—Tc: Cl. VIII A1; W 16; H 30; I 5; B 13a; Tp 7b

Other examples of *shabtis* for Ankhefenmut are found in museums in Amiens,¹ Berlin,² Brussels,³ Cairo,⁴ Copenhagen,⁵ Cortona,⁶ Khazan,⁷ Leiden,⁸ Lisbon,⁹

1 Dautant et al. 2013, Table 1 n. 34.

2 Roeder 1913, n. 11948–49.

3 <http://carmentis.kmkg-mrah.be>, E 05431 a–b.

4 Newberry 1957, 298–299 C.G. 48160–69.

5 Mogensen 1918, n. 3947–3949.

6 Botti 1955, 71 n. 89.

7 Berlev and Hodjash 1998, n. 32.

8 Schneider 1977, n. 4.5.1. 1–2.

9 Sociedade de Geografia de Lisboa, n. 2507-34 A. Araujo 2003, 602 n. 8.

London,¹⁰ Madrid,¹¹ Marseille,¹² Paris,¹³ Roanne,¹⁴ Stockholm,¹⁵ Uppsala,¹⁶ Wien¹⁷ and in private collections.¹⁸

Burial Assemblage

The son of the High Priest of Amun Menkheperra, Ankhefenmut was “Divine father of Amun and Mut”. His outer coffin, usurped from Tenetmerpare, is kept in the Egyptian Museum in Cairo, together with the inner coffin and the mummy board,¹⁹ as well as the funerary papyri.²⁰ The funerary equipment included a green feldspar scarab and two *shabti*-boxes.²¹

Bibliography

A. Pellegrini, Bessarione VII (1899–1900), p. 14 n. 70.

-
- 10 Petrie 1935, UC 434–435. http://www.britishmuseum.org/research/collection_online, EA 24807–08.
- 11 <http://ceres.mcu.es>, n. 18276–77.
- 12 Dautant et al. 2013, Table 1 n. 34.
- 13 Louvre E 22075–76.
- 14 Gabolde 1990, 107–108 n. 89.
- 15 <http://collections.smvk.se/carlotta-mhm>, NME 916.
- 16 Sandman 1931, 101 n. 18.
- 17 Haslauer 1992, AS 6190.
- 18 Aubert 1998, n. 6.
- 19 Niwiński 1988, 130–131 n. 140. Outer coffin, inner coffin and mummy-cover; gilding. Dating: middle 21st Dynasty.
- 20 Niwiński 1989, p. 289 n. 103—S.R.VII.10274 (Book of the Amduat, type A.II.2a) and p. 290 n. 105—S.R.VII.10652 (Book of the Death probably enclosed in an Osiris figure, type BD.III.1b).
- 21 Aston 2009, 190–191 TG. 813.

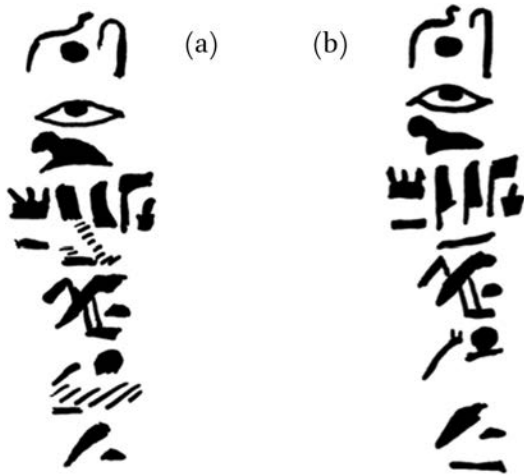

FIGURE 204 Shabtis of Ankhefenmut (Inscriptions)



FIGURE 205 Shabtis of Ankhefenmut

7. Shabtis of Ankhefenkhonsu (*ꜥnh.f-n-hnsw*)

Inv. NN. 8558, 8610 and 8611

Cairo List: 1

Daressy List: A.33

Height: (a) 11 cm; (b) 11,2 cm; (c) 11,2 cm

Raw Material: Red pottery painted white.

State of Preservation: Good. The white paint has faded away at some areas.

Description

Mummiform servant.

Face poorly modeled, with eyes, brows and lips outlined in black.

Ears slightly modeled over the lappets of the tripartite wig (modeled).

Arms crossed over the chest grasping the hoes.

Basket on the back.

Inscription and iconographic details (hoes and basket) are outlined in black.

Inscription

Painted black. One column of hieroglyphs.

“The Osiris Ankhefenkhonsu, justified”.

Typology

4.5.1—Tc: Cl. VIII A1; W 16; H 8; I 5; B 13a; Tp 7b

Other examples of *shabtis* for Ankhefenkhonsu are to be found in museums in Aix-les-Bains,¹ Basel,² Brussels,³ Cairo,⁴ Chicago,⁵ Copenhagen,⁶ Cortona,⁷ Lei-

1 Aubert 1988, 5 n. 268.

2 Schlögl and Brodbeck 1990, 166 n. 101a.

3 <http://carmentis.kmkg-mrah.be>, E 05400 c–d.

4 Newberry 1957, 283–284 CG 47984–48003.

5 <http://www.artic.edu/aic/collections/artwork/136591>.

6 Mogensen 1918, n. 3915–3918.

7 Botti 1955, 71 n. 103.

den,⁸ Lisbon,⁹ London,¹⁰ Madrid,¹¹ Oslo,¹² Paris,¹³ Roanne,¹⁴ St. Gallen,¹⁵ Stockholm¹⁶ and Wien.¹⁷

Burial Assemblage

At least 5 individuals named Ankhefenkhonsu seem to have been buried in Bab el-Gasus and two series of *shabtis* with this name were found in the tomb. However, it is difficult to determine which coffin set they belonged to, or whether both types were made for the same individual. Daessy records all the statuettes with the number A.108, but according to L. Aubert the two series of statuettes, different in proportion, size and text, are to be ascribed to distinct burial assemblages: she has attributed those with small eyes to A.33, and those with large eyes to A.108.¹⁸

Following Aubert, the first three samples from Florence may belong to the burial assemblage A.33, while the fourth (see N.Cat. 7) could be associated with A.108.

The coffin set of Ankhefenkhonsu (A.33) is in Copenhagen,¹⁹ while his funerary papyrus is in Cairo Museum.²⁰ The titles “Divine father of Amun” and “Great priest allowed to stay before Amun at Karnak” are mentioned in his burial equipment, which includes an Osiris shroud, three linen “serviettes” wrapped around the body, mummy braces, a green glazed heart scarab, several glazed and gold amulets, a copper embalmer’s plaque, a bronze pectoral on the chest and a statuette of Osiris containing an abbreviated version of the Book of the Dead.²¹

8 Schneider 1977, n. 4.5.1. 3–4–5–6.

9 Sociedade de Geografia de Lisboa, n. 2507-27 A and B. Araujo 2003, 605–606 n. 11–12. Museu Nacional de Arqueologia, E 92–94. Araujo 2003, 705–707 n. 5–7.

10 Petrie 1935, n. 385–400–449, 460. http://www.britishmuseum.org/research/collection_online, EA 24801–02 and 24843–44.

11 MAN 18260 and 18212–13.

12 Naguib 1985, EM 811.

13 Aubert 1998 n. 7 (Louvre 22050).

14 Gabolde 1990, 108–109 n. 90.

15 Schlögl and Brodbeck 1990, 167 n. 101b and 101c.

16 <http://collections.smvk.se/carlotta-mhm>, NME 912.

17 Haslauer 1992, AS 618.

18 Aubert 1998, 56–57 n. 7.

19 Niwiński 1988, 135 n. 165. Outer coffin, inner coffin and mummy-board. Dating: middle/late 21st Dynasty.

20 Niwiński 1989, 271–272 n. 52—S.R.IV.1003 (Book of the Amduat, type A.II.2a).

21 Aston 2009, 170 TG. 706.

Bibliography

A. Pellegrini, *Bessarione VII* (1899–1900), p. 14 n. 69.

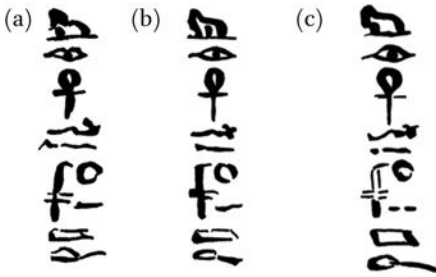

FIGURE 206 Shabtis of Ankhefenkhonsu
(Inscriptions)



FIGURE 207 Shabtis of Ankhfenkhonsu

8. Shabti of Ankhefenkhonsu (*ḥnḫ.f-n-ḥnsw*)

Inv. N. 8559

Cairo List: 27

Daressy List: A.108

Height: 11 cm

Raw Material: Red pottery painted white.

State of Preservation: Good. The inscription is faint in the lower part.

Description

Mummiform servant.

Faced poorly modeled with eyes and brows outlined in black.

Ears modeled over the lappets of the tripartite wig (modeled).

Arms crossed over the chest grasping the hoes.

Basket on the back.

Iconographic details (hoes and basket) are outlined in black.

Inscription

Painted black. One column of hieroglyphs.

“The Osiris Ankhefenkhonsu”.

Typology

4.5.1—Tc: Cl. VIII A1; W 16; H 8; I 5; B 13a; Tp 7b

Other examples of *shabtis* belonging to this series are found in museums in Basel,¹ Brussels,² Clermont-Ferrand,³ Lisbon,⁴ Lyon,⁵ Madrid,⁶ Oslo,⁷ Paris⁸ and Uppsala.⁹

1 Schlögl and Brodbeck 1990, 166 n. 101.

2 <http://carmentis.kmkg-mrah.be>, E 05400 a–b.

3 Dautant et al. 2013, Table 1 n. 1.

4 Sociedade de Geografia de Lisboa, n. 2507-1 A and B. Araujo 2003, 603–604 n. 9–10.

5 Dautant et al. 2013, Table 1 n. 1.

6 MAN 18261.

7 Naguib 1985, EM 8110.

8 Aubert 1998 n. 7 (Louvre 22050).

9 Sandman 1931, 96 n. 3.

Burial Assemblage

This is an example of the second series of *shabtis* for Ankhefenkhonsu found in Bab el-Gasus.

L. Aubert ascribes these statuettes to the burial assemblage A.108 belonging to Ankhefenkhonsu, “Divine father of Amun”, “beloved of the god”, “Overseer of the secrets” and “Chief of the engravers”. His coffin and mummy board are in the Egyptian Museum in Cairo¹⁰ together with his funerary papyrus.¹¹ The burial equipment included an Osiris shroud, a blue glazed heart scarab and a wax embalmer’s plaque. His *shabtis* were kept in a *shabti*-box.¹²

Bibliography

Unpublished.

-
- 10 Niwiński 1988, 124 n. 106. Outer coffin, inner coffin and mummy-board. Dating: middle 21st Dynasty.
- 11 Niwiński 1989, p. 260 n. 19—S.R.IV.556 (Book of the Dead, type BD.II.1) and probably p. 259 n. 17—S.R.IV. 554 (Book of the Amduat, type A.II.1a) and p. 260 S.R.IV.556 (Book of the Dead, type BD.II.1).
- 12 Aston 2009, 183 TG. 108. The author ascribes all the red pottery *shabtis* named Ankhefenkhonsu to this deceased.



FIGURE 208
Shabti of Ankhefenkhonsu (Inscription)



FIGURE 209 Shabti of Ankhefenkhonsu

9. Shabtis of Ankhesenmut (*ḥnḥ.s-n-Mwt*)

Inv. NN. 8562, 8563 and 8541

Cairo List: 33

Daressy List: A.38

Height: (a) 11 cm; (b) 10,9 cm; (c) 11,2 cm

Raw Material: Red pottery painted blue.

State of Preservation: Good. In (a) the painting is lost in the lower part and the inscription has almost disappeared; in (b) and (c) the painting is almost totally lost and the inscriptions are faded in the lower part.

Description

Mummiform servant.

Face crudely modeled.

Ears modeled over the lappets of the tripartite wig (modeled).

Arms crossed over the chest grasping the hoes.

Basket on the back.

Iconographic details (hoes and basket) are outlined in black.

Inscription

Painted black. One column of hieroglyphs.

“The Osiris Ankhesenmut, justified”.

Typology

4.5.1—Tc: Cl. VIII A1; W 16; H 8; I 5; B 13a; Tp 7b

Other examples of *shabtis* for Ankhesenmut are to be found in museums in Basel,¹ Brussels,² Cairo,³ Copenhagen,⁴ Lisbon,⁵ London,⁶ Madrid,⁷ Marseille,⁸ Oslo,⁹ Paris,¹⁰ Roanne,¹¹ St. Gallen¹² and Stockholm.¹³

Burial Assemblage

Ankhesenmut had the titles of “Chantress of Amun” and “Musician of the choir of Mut”. Her coffin is in Cairo¹⁴ together with her funerary papyrus.¹⁵ The deceased was supplied with an Osiris shroud, mummy braces, a heart scarab, wax figurines depicting the Sons of Horus and a *shabti*-box.¹⁶

Bibliography

A. Pellegrini, *Bessarione* VII (1899–1900), p. 14 n. 71.

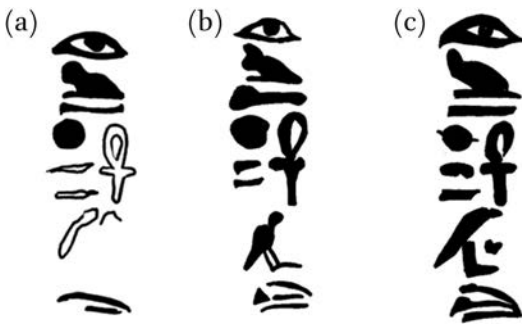

FIGURE 210 Shabtis of Ankhesenmut (Inscriptions)

- 1 Schlögl and Brodbeck 1990, 187 n. 114c.
- 2 <http://carmentis.kmkg-mrah.be>, E 05409 a–b and E 05430 a–b.
- 3 Newberry 1957, 300–301 CG 48190–48209.
- 4 Mogensen 1918, n. 3939–3940.
- 5 Sociedade de Geografia de Lisboa, n. 2507-13 B and 2507-33 A. Araujo 2003, 608–609 n. 14–15. Museu Nacional de Arqueologia, E 86. Araujo 2003, 709 n. 9.
- 6 Petrie 1935, n. 397. http://www.britishmuseum.org/research/collection_online, EA 24837–38 and 24855–56.
- 7 <http://ceres.mcu.es>, n. 18324.
- 8 Dautant et al. 2013, Table 1 n. 33.
- 9 Naguib 1985, EM 8108 and EM 8118.
- 10 Aubert 1998 n. 8 (Louvre 20226).
- 11 Gabolde 1990, 110 n. 92.
- 12 Schlögl and Brodbeck 1990, 186 n. 114.
- 13 <http://collections.smvk.se/carlotta-mhm>, NME 917–918.
- 14 Niwiński 1988, 126 n. 115. Outer coffin, inner coffin and mummy-board. Dating: middle 21st Dynasty (mummy braces of H.P. Pinudjem 11, mummy-linen of King Amenemope and H.P. Pinudjem 11).
- 15 Niwiński 1989, 285 n. 90—S.R.VII.10255 (Book of the Dead between the legs, type BD.II.1).
- 16 Aston 2009, 170 TG. 711.



FIGURE 211 Shabtis of Ankhnesenmut

10. Shabti of Ankhesenmut (𓎡nḫ.s-n-Mwt)

Inv. N. 8540

Cairo List: 34

Daressy List: A.38

Height: 11,4 cm

Raw Material: Red pottery, painted blue.

State of Preservation: Good. The hands are lost. The blue paint is lost.

Description

Mummiform servant.

Eyes painted black. Ears modeled over the lappets of the tripartite wig (modeled).

Arms crossed over the chest grasping the hoes.

Basket on the back.

Iconographic details (hoes and basket) are outlined in black.

Inscription

Painted black. One column of hieroglyphs.

“The Osiris Ankhesenmut, justified”.

Typology

4.5.1—Tc: Cl. VIII A1; W 16; H ?; I 5; B 13a; Tp 7b

Other examples of this type of statuette are found in museums in Basel,¹ Cairo,² Kiev,³ Leiden,⁴ Lisbon,⁵ Madrid,⁶ Roanne,⁷ St. Gallen⁸ and Wien.⁹

1 Schlögl and Brodbeck 1990, 187 n. 114b.

2 Newberry 1957, 300–301 CG 48190–209.

3 Berlev and Hodjash 1998, n. 86–87.

4 Schneider 1977, n. 4.5.1. 7–8–9–10.

5 Sociedade de Geografia de Lisboa, n. 2507-13 A and 2507-33 B. Araujo 2003, 607 and 610 n. 13 and 16. Museu Nacional de Arqueologia, E 85 and E 454–455. Araujo 2003, 708–711 n. 8, 10–11.

6 MAN 18285.

7 Gabolde 1990, 109 n. 91.

8 Schlögl and Brodbeck 1990, 186 n. 114a.

9 Haslauer 1992, AS 6199.

Burial Assemblage

This could be an example of a second series of *shabtis* for Ankhesenmut: the body is thicker than those of the former examples (see N. Cat. 9) and the features of the inscription are quite different mainly in the writing of the epithet “Osiris”.

Bibliography

Unpublished.



FIGURE 212
Shabti of Ankhesenmut (Inscription)



FIGURE 213 Shabti of Ankhesenmut

11. Shabtis of Userhatmes (*Wsr-ḥꜣt-ms*)

Inv. NN. 8596 and 8597

Cairo List: 7

Daressy List: A.105

Height: (a) 12,2 cm; (b) 9,7 cm

Raw Material: Blue faience.

State of Preservation: Good.

Description

Mummiform servant.

Face finely shaped with eyes and brows outlined in black.

Ears modeled over the lappets of the tripartite wig (modeled), which is adorned with *seshed*-headband.

The statuette (a) shows breasts modeled below the lappets.

The arms are crossed over the chest grasping the hoes.

A basket figures on the back.

Iconographic details (headband, hoes and basket) are outlined in black.

Inscription

Painted black. One column of hieroglyphs.

“The Osiris Userhatmés, justified”.

Typology

(a) 4.3.1—Tc: Cl. VIII B1; W 19; H 8; I 5; B 12b; Tp 7b

(b) 4.3.1—Tc: Cl. VIII A1; W 19; H 1; I 5; B 12b; Tp 7b

Other examples of the female type are found in museums in Amiens,¹ Brussels,² Copenhagen,³ Cortona,⁴ Leiden,⁵ Lisbon,⁶ London,⁷ Paris,⁸ Roanne,⁹ Wien¹⁰ and in private collections.¹¹

Shabtis of the male type are found in Brussels,¹² Copenhagen,¹³ Leiden,¹⁴ Lisbon,¹⁵ Oslo¹⁶ and in private collections.¹⁷

Burial Assemblage

The Osiris “*wab*-priest at the prow of the Sacred Barque of Mut, mistress of the sky”, “*wab*-priest of Amun, king of the gods” and “Scribe of the treasury of the supreme chief of the concubines of Amun” was supplied with two types of *shabtis*: tall female (a) and small male (b).

The coffin and the mummy board of Userhatmes are in the Egyptian Museum in Cairo¹⁸ together with his funerary papyri.¹⁹ The funerary equipment included an Osiris shroud, mummy braces, a white feldspar scarab, a wax embalmer’s plaque, a funerary wooden stela and two *shabti*-boxes.²⁰

Bibliography

A. Pellegrini, Bessarione VII (1899–1900), p. 15 n. 78–79.

-
- 1 Dautant et al. 2013, Table 1 n. 7.
 - 2 <http://carmentis.kmkg-mrah.be>, E 05405 a–b.
 - 3 Mogensen 1918, n. 3965.
 - 4 Botti 1955, 71 n. 110.
 - 5 Schneider 1977, n. 4.3.1 17.
 - 6 Sociedade de Geografia de Lisboa, n. 2507-7 A. Araujo 2003, 611 n. 17.
 - 7 http://www.britishmuseum.org/research/collection_online, EA 24803–04.
 - 8 Louvre E 22091.
 - 9 Gabolde 1990, 110–111 n. 93.
 - 10 Haslauer 1992, AS 8413. Another statuette, AS 8367, shows a special text: “The Osiris Userhatmés, justified Usermaatse-Setepenre” [forename of Ramses II].
 - 11 Janes 2002, 77–78 n. 37b; Aubert 1998 n. 9.
 - 12 E 5405 A and B. Seipel 1989, 208–209 n. 187–188.
 - 13 Mogensen 1918, n. 3966.
 - 14 Schneider 1977, n. 4.3.116.
 - 15 Sociedade de Geografia de Lisboa, n. 2507-7 B. Araujo 2003, 612 n. 18.
 - 16 Naguib 1985, EM 8091.
 - 17 Janes 2002, 76–77 n. 37a.
 - 18 Niwiński 1988, 123 n. 104. Outer coffin, inner coffin and mummy-board. Dating: middle 21st Dynasty (mummy braces of H.P. Pinudjem II, mummy-linen with the dates year 48 of H.P. Menkheperre and year 1 of Amenemope).
 - 19 Niwiński 1989, p. 275 n. 62—S.R.VII.10225 (Book of the Amduat, type A.1.1) and pp. 283–284 n. 86—S.R.VII.10249 (Book of the Dead probably enclosed in an Osiris figure, type BD.III.1a).
 - 20 Aston 2009, 182 Tg. 778.

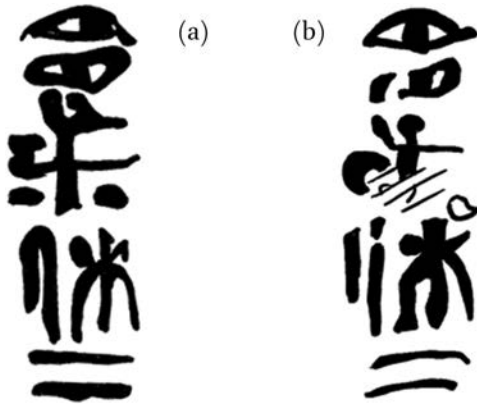

FIGURE 214 Shabtis of Userhatmes (Inscriptions)



FIGURE 215 Shabtis of Userhatmes

12. Shabtis of Bakenmut (*B3k-n-Mwt*)

Inv. NN. 8546 and 8547

Cairo List: 18

Daressy List: A.94

Height: 9 cm

Raw Material: Light blue faience

State of Preservation: Good. In (a) the glaze is damaged in the lower part. In (b) the left arm is broken and the hand is lost.

Description

- (a) Mummiform servant. Face slightly modeled, eyes and brows outlined in black. Ears modeled over the lappets of the tripartite wig (modeled). The wig is adorned with a *seshed*-headband. Arms crossed over the chest grasping the hoes. Basket on the back.
- (b) Overseer. Eyes and brows painted black. Tripartite wig with modeled lappets. The wig is adorned with a *seshed*-headband. Left arm crossed over the chest grasping the whip (painted black) and the right arm extended along the body. Long kilt carved in high relief. Iconographic details (headband, hoes and basket) are outlined in black.

Inscription

Painted black. One column of hieroglyphs.

“The Osiris Bakenmut, justified”.

Typology

- (a) 4-3.1—Tc: Cl. VIII A2; W 19; H 1; I 5; B 12b; Tp 7b
- (b) 4-3.5—Tc: Cl. IX C; W 19; H 33; I 12; B /; Tp 7b

Other examples of mummiform servant for Bakenmut are found in museums in Amiens,¹ Boulogne-sur-mer,² Basel,³ Brussels,⁴ Cairo,⁵ Copenhagen,⁶

1 Dautant et al. 2013, Table 1 n. 18.

2 Dautant et al. 2013, Table 1 n. 18.

3 Schlögl and Brodbeck 1990, 169 n. 103a.

4 <http://carmentis.kmkg-mrah.be>, E 05414 (with titles).

5 Newberry 1957, pp. 29–30 CG 46604–46623 and p. 35 CG 46697.

6 Mogensen 1918, n. 3995 and 3997 (with the title “priest of Mut”).

Cortona,⁷ Leiden,⁸ Lisbon,⁹ London,¹⁰ Madrid,¹¹ Paris,¹² Roanne,¹³ St. Gallen,¹⁴ Stockholm,¹⁵ Uppsala,¹⁶ Wien¹⁷ and private collections.¹⁸

Burial Assemblage

Two men named Bakenmut were buried in Bab el-Gasus.

The “Divine father of Amun” Bakenmut (A.40) was buried in a coffin set now in London.¹⁹

The “wab-priest”, “goldsmith in the Estate of Amun” and “Divine father of Mut” Bakenmut (A.94) was buried in a coffin set now in Istanbul.²⁰

The funerary papyri of the Egyptian Museum in Cairo²¹ and the funerary statuettes here presented can be attributed to the deceased A.94.²² He was accompanied by two *shabti*-boxes and a statuette of Osiris containing a Book of the Dead.²³

Bibliography

A. Pellegrini, *Bessarione VII* (1899–1900), p. 16 n. 83.

-
- 7 Botti 1955, 71–72 n. 85 and 97.
 8 Schneider 1977, n. 4.3.1 18–19.
 9 Sociedade de Geografia de Lisboa, n. 2507-18 A and B. Araujo 2003, 613–614 n. 19–20.
 10 Petrie 1935, UC 294. http://www.britishmuseum.org/research/collection_online, EA 24863–64.
 11 MAN 18294–95.
 12 Louvre E 22102.
 13 Gabolde 1990, 111–112 n. 94.
 14 Schlögl and Brodbeck 1990, 169 n. 103.
 15 <http://collections.smvk.se/carlotta-mhm>, MM 14987.
 16 Sandman 1931, 100 n. 16.
 17 Haslauer 1992, AS 6251–6252.
 18 Aubert 1998, n. 10.
 19 Niwiński 1988, 152–153 n. 266. Outer coffin, inner coffin and mummy-board. Dating: late 21st Dynasty.
 20 Niwiński 1988, 143 n. 209. Inner coffin. Dating: middle/late 21st Dynasty.
 21 Niwiński 1989, p. 269 n. 45—S.R.IV.982 (JE 95880—Book of the Dead enclosed in an Osiris figure, type BD.III.1a) and p. 277 n. 68—S.R.VII.10231 (Book of the Amduat between the legs, type A.III.2a).
 22 Aubert 1998, 60. For the deceased A.40, Aubert notices shabtis crafted in clay painted green.
 23 Aston 2009, 179 TG. 767.

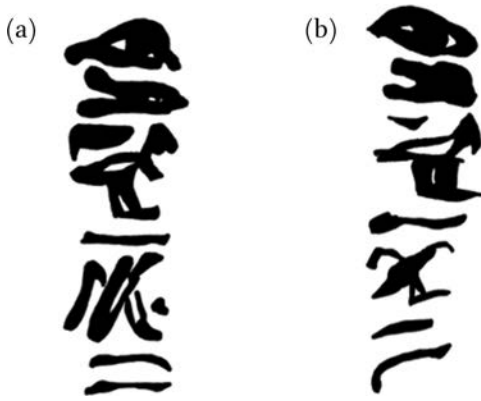

FIGURE 216 Shabtis of Bakenmut (Inscriptions)



FIGURE 217 Shabtis of Bakenmut

13. Shabti of Paiefadjer (*P3y.f-ꜥdr*)

Inv. N. 8579

Cairo List: 22

Daressy List: A 99

Height: 9,2 cm

Raw Material: Light blue faience

State of Preservation: Good. The inscription is faded in the final part.

Description

Mummiform servant.

Face crudely shaped, with the eyes summarily outlined in black.

Big ears modeled over the lappets of the tripartite wig (striated and modeled).

Arms crossed over the chest grasping the hoes.

Basket on the back.

Iconographic details (striated wig, hoes and basket) are outlined in black.

Inscription

Painted black. One column of hieroglyphs.

“The Osiris, *wab*-priest and lector priest, Paiefadjer”.

Typology

4.3.1—Tc: Cl. VIII A2; w front: 22—back: plain; H 1; I 5; B 12b; Tp 7b

Other examples of *shabtis* for Paiefadjer are found in museums in Amiens,¹ Basel,² Berlin,³ Brussels,⁴ Cairo,⁵ Cleveland,⁶ Leiden,⁷ Lisbon,⁸ London,⁹ Ma-

1 Dautant et al. 2013, Table 1 n. 22.

2 Schlögl and Brodbeck 1990, 197 n. 121a.

3 Roeder 1913, n. 11971 (two examples).

4 <http://carmentis.kmkg-mrah.be>, E 05418 and E 05448.

5 Newberry 1957, 77–78 CG 47151–47160.

6 Berman and Kenneth 1999, 358 n. 270.

7 Schneider 1977, n. 4.3.1. 34–35–36.

8 Sociedade de Geografia de Lisboa, n. 2507-22 A and B. Araujo 2003, 622–623 n. 28–29. Museu Nacional de Arqueologia, E 114 and E 462. Araujo 2003, 722–723 n. 22–23.

9 http://www.britishmuseum.org/research/collection_online, EA 24811–12.

drid,¹⁰ Marseille,¹¹ Oslo,¹² Roanne,¹³ St. Gallen,¹⁴ Voronezh,¹⁵ Yuriev¹⁶ and private collections.¹⁷

Burial Assemblage

The coffin set of the “Chief-lector priest” Paiefadjer is in Cairo Museum¹⁸ and the funerary equipment included two *shabti*-boxes.¹⁹

Bibliography

Unpublished.

10 <http://ceres.mcu.es>, n. 18302–03.

11 Dautant et al. 2013, Table 1 n. 22.

12 Naguib 1985, EM 8082 and EM 8093.

13 Gabolde 1990, 112–113 n. 95.

14 Schlögl and Brodbeck 1990, 197 n. 121.

15 Berlev and Hodjash 1998, n. 74.

16 Berlev and Hodjash 1998, n. 75.

17 Aubert 1998, n. 11.

18 Niwiński 1988, 118–119 n. 82. Outer coffin, inner coffin and mummy-board. Dating: middle/late 21st Dynasty.

19 Aston 2009, 181 TG. 772.

AN
S
D
X
=
T
=

FIGURE 218
Shabti of Paiefadjer (Inscription)



FIGURE 219 Shabti of Paiefadjer

14. Shabtis of Pakharu (*Pꜣ-hꜣrw*)

Inv. NN. 8624 and 8625

Cairo List: 39

Daressy List: A.115

Height: (a) 8 cm; (b) 8,5 cm

Raw Material: Blue faience

State of Preservation: Good

Description

- (a) Mummiform servant. Features of the face slightly modeled, eyes and brows outlined in black. Ears modeled over the lappets of the tripartite wig (modeled and striated). Arms crossed over the chest grasping the hoes. Basket on the back.
- (b) Overseer. Eyes and brows outlined in black. Ears modeled over the lappets of the tripartite wig (modeled and striated). Left arm crossed over the chest grasping the whip (painted black) and the right arm extended along the body. Long kilt carved in high relief. Iconographic details (striped wig, hoes, flail and basket) are outlined in black.

Inscription

Painted black. One column of hieroglyphs.

- (a) “That may shine the Osiris Pakharu”.
- (b) “The Osiris Pakharu, justified”.

Typology

- (a) 4-3-1—Tc: Cl. VIII A2; w front: 21—back: plain; H 1; I 5; B 14; Tp 7b
- (b) 4-3-5—Tc: Cl. IX C; w front: 21—back: plain; H 33; I 15; B /; Tp 7b

Other examples of mummiform *shabtis* of Pakharu are found in museums in Basel,¹ Berlin,² Brussels,³ Cairo,⁴ Cortona,⁵ Kazan,⁶ Lisbon,⁷ London,⁸ Lyon,⁹ Madrid,¹⁰ Oslo,¹¹ Roanne,¹² St. Gallen,¹³ Wien¹⁴ and private collections.¹⁵

Burial Assemblage

Despite the foreign name (Pakharu means “the Palestinian”) of the deceased, the burial equipment (A. 115) holds titles including: “Prophet of Amun”, “Divine father”, “Beloved of the god”, “The one who opens the doors of the sky in Karnak”, “Chief-lector of Amun”, “Overseer of the secrets of Amun, Mut and Khonsu in the sky, on the earth and in the Duat”, “Prophet of Khonsu in Thebes”, “*Setem*-priest in the horizon of eternity”.

The coffin and the mummy-board of Pakharu are currently kept in the National Museum of Alexandria.¹⁶ His funerary papyri are kept in the Egyptian Museum in Cairo.¹⁷ The funerary equipment included an Osirian shroud, mummy braces and two *shabti*-boxes.¹⁸

Bibliography

A. Pellegrini, Bessarione VII (1899–1900), p. 19 n. 99–100.

-
- 1 Schlögl and Brodbeck 1990, 181 n. 112b.
 - 2 Roeder 1913, n. 11965 (two examples).
 - 3 <http://carmentis.kmkg-mrah.be>, E 05436 a–b.
 - 4 Newberry 1957, 44–45 CG 46779–46788.
 - 5 Botti 1955, 72 n. 18.
 - 6 Berlev and Hodjash 1998, n. 38–39.
 - 7 Sociedade de Geografia de Lisboa, n. 2507-39 B and 2507-40 B. Araujo 2003, 615–616 n. 21–22. Museu Nacional de Arqueologia, E 115. Araujo 2003, 715 n. 15.
 - 8 Petrie 1935, n. 56, 284, 458. http://www.britishmuseum.org/research/collection_online, EA 24845 (overseer) and 24846.
 - 9 Dautant et al. 2013, Table 1 n. 39.
 - 10 <http://ceres.mcu.es>, n. 18336.
 - 11 Naguib 1985, EM 8084 and 8099.
 - 12 Gabolde 1990, 113–114 n. 96.
 - 13 Schlögl and Brodbeck 1990, 181 n. 112a.
 - 14 Haslauer 1992, AS 8800 and AS 8826.
 - 15 Aubert 1998, n. 13; Janes 2002, 82–83 n. 40.
 - 16 Niwiński 1988, 125 n. 113. Outer coffin, inner coffin and mummy-board. Dating: middle 21st Dynasty (mummy braces of H.P. Menkheperre).
 - 17 Niwiński 1989, pp. 267–268 n. 42—s.r.IV.979 (Book of the Amduat between legs, type A.1.1) and p. 299 n. 129—JE 95705 (Book of the Dead probably enclosed in an Osiris figure, type BD).
 - 18 Aston 2009, 185 TG.788.

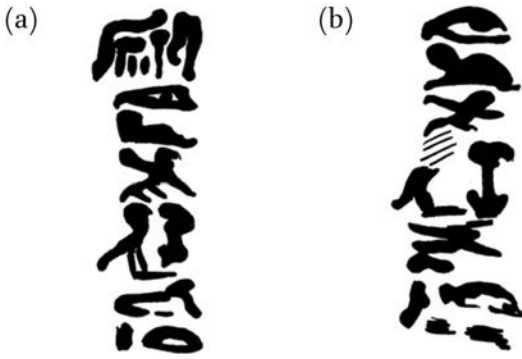

FIGURE 220 Shabtis of Pakharu (Inscriptions)



FIGURE 221 Shabtis of Pakharu

15. Shabtis of Pasebakhaenniut (*Pꜣ-sbꜣ-ḥ-n-niwt*)

Inv. NN. 8550 and 8551

Cairo List: 20

Daressy List: A.85

Height: 9 cm

Raw Material: Light blue faience

State of Preservation: Good. Breaks have been repaired in the lower part of the statuettes.

Description

Mummiform servant.

Face poorly modeled with eyes and brows outlined in black.

Ears modeled over the lappets of the tripartite wig (modeled). Wig adorned with *shed*-headband painted black.

Exceptionally, the arms are not crossed over the chest but brought over the belly grasping flails. Basket on the back.

Iconographic details (headband, flails and basket) are outlined in black.

Inscription

Painted black. One column of hieroglyphs.

“The Osiris Pasebakhemniut, justified”.

Typology

(a) 4.3.1—Tc: Cl. VIII A1; W 20; H 10; I 12; B 12b; Tp 7b

(b) 4.3.1—Tc: Cl. VIII A1; W 19; H 10; I 12; B 12b; Tp 7b

Other *shabtis* for this owner are found in museums in Amiens,¹ Basel,² Berlin,³ Brussels,⁴ Cairo,⁵ Cortona,⁶ Leiden,⁷ Lisbon,⁸ London,⁹ Madrid,¹⁰ Marseille,¹¹ Paris,¹² Roanne,¹³ St. Gallen,¹⁴ Stockholm,¹⁵ Voronezh¹⁶ and Wien.¹⁷

Burial Assemblage

The coffin set of Pasebakhaenniut (or “Psusennes” in its Hellenized form) is kept in the Egyptian Museum in Cairo¹⁸ together with his funerary papyrus.¹⁹ The deceased had the titles of “Divine father of Amun” and “Prophet of Sobek”. His burial equipment included a green basalt heart scarab, a gilt bronze pectoral, a gilt bronze embalmer’s plaque, a gilt bronze uraeus on the forehead, wax figurines of the Sons of Horus (found within the body cavity), mummy braces, three blue glazed amulets and two *shabti*-boxes.²⁰

Bibliography

Unpublished.

-
- 1 Dautant et al. 2013, Table 1 n. 20.
 - 2 Schlögl and Brodbeck 1990, 164 n. 99.
 - 3 Roeder 1913, n. 11976 (two examples).
 - 4 <http://carmentis.kmkg-mrah.be>, E 05416 a–b.
 - 5 Newberry 1957, 56–57 CG 46933–46937.
 - 6 Botti 1955, 72 n. 80.
 - 7 Schneider 1977, n. 4.3.1. 37–38.
 - 8 Sociedade de Geografia de Lisboa, n. 2507-20 A and B. Araujo 2003, 617–618 n. 23–24. Museu Nacional de Arqueologia, E 111. Araujo 2003, 716 n. 16.
 - 9 http://www.britishmuseum.org/research/collection_online, EA 24877–78.
 - 10 MAN 18298–99.
 - 11 Dautant et al. 2013, Table 1 n. 20.
 - 12 Aubert 1998, n. 14.
 - 13 Gabolde 1990, 114–115 n. 97.
 - 14 Schlögl and Brodbeck 1990, 180 n. 112.
 - 15 <http://collections.smvk.se/carlotta-mhm>, NME 908.
 - 16 Berlev and Hodjash 1998, n. 77.
 - 17 Haslauer 1992, AS 6233.
 - 18 Niwiński 1988, 126 n. 118. Outer coffin, inner coffin and mummy-board. Dating: middle/late 21st Dynasty.
 - 19 Niwiński 1989, 289 n. 102—S.R.VII.10273 (Book of the Amduat between legs, type A.II.1b).
 - 20 Aston 2009, 178 TG. 758.

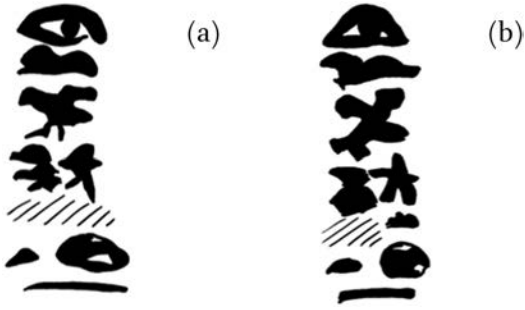

FIGURE 222 Shabtis of Pasebakraenniut (Inscriptions)



FIGURE 223 Shabtis of Pasebakraenniu

16. Shabtis of Padiamun (*Pꜣ-di-Īmn*)

Inv. NN. 8560 and 8561

Cairo List: 3

Daressy List: A.114

Height: (a) 11,6 cm; (b) 11,5 cm

Raw Material: Pottery painted white.

State of Preservation: Good. In (a) a break has been repaired in the lower part.

In (b) the painting is nearly lost and the inscription is faint.

Description

Mummiform servant.

Face crudely shaped with eyes, brows and lips outlined in black.

Striated tripartite wig adorned with *sheshed*-headband. Modeled lappets. Short collar between the lappets. Arms crossed over the chest grasping the hoes.

In (a) the hoes are modeled.

Basket on the back.

Iconographic details (striped wig, hoes and basket) are outlined in black.

Inscription

Painted black. One column of hieroglyphs.

“The Osiris, divine father, Padiamun justified”.

Typology

(a) 4.5.1—Tc: Cl. VIII A1; W 26; H 16; I 5; B 17; Tp 7b

(b) 4.5.1—Tc: Cl. VIII A1; W 29; H 16; I 5; B 17; Tp 7b

Other examples of *shabtis* for Padiamun are found in Basel,¹ Berlin,² Brussels,³ Cairo,⁴ Cleveland,⁵ Copenhagen,⁶ Leiden,⁷ Lisbon,⁸ London,⁹ Paris,¹⁰ Roanne,¹¹ St. Gallen,¹² Stockholm,¹³ Toulouse,¹⁴ Uppsala¹⁵ and Wien.¹⁶

Burial Assemblage

At least five men with this name (Padiamun) seem to have been buried in Bab el-Gasus. Daressy ascribes all the *shabtis* with this name to the deceased A.114, but we have two different types of statuettes.

These objects belong to the first series, taller and with one single column of hieroglyphs.

This type can be ascribed to the burial assemblage of A.114. The “Divine father”, “Overseer of the secrets”, “Priest of Amun” and “Chief-lector” Padiamun was the son of Pakharu (see N.Cat. 14) and was buried in a coffin set kept in Cairo Museum¹⁷ together with his funerary papyri.¹⁸ The deceased was supplied with an Osiris shroud, mummy braces, a wax heart amulet, feldspar scarab and amulet, wax embalmer’s plaque and two *shabti*-boxes.¹⁹

1 Schlögl and Brodbeck 1990, 185 n. 113c.

2 Roeder 1913, n. 11954.

3 <http://carmentis.kmkg-mrah.be>, E 05402 a (overseer) and b.

4 Newberry 1957, 286–287 CG 48024 and 48039.

5 Berman and Kenneth 1999, 360–361 n. 274.

6 Mogensen 1918, n. 3921–3922.

7 Schneider 1977, n. 4.5.1. 13–14, with traces of green painting and varnish.

8 Sociedade de Geografia de Lisboa, n. 2507-3 A. Araujo 2003, 620 n. 25. Museu Nacional de Arqueologia, E 96. Araujo 2003, 717 n. 17.

9 http://www.britishmuseum.org/research/collection_online, EA 24849–50.

10 Aubert 1998, n. 15 (Louvre E 22056). The scholar ascribes all the statuettes named Padiamun to the deceased A.114.

11 Gabolde 1990, 116–117 n. 99.

12 Schlögl and Brodbeck 1990, 182 n. 113.

13 <http://collections.smvk.se/carlotta-mhm>, NME 911.

14 Dautant et al. 2013, Table 1 n. 3.

15 Sandman 1931, 104 n. 26.

16 Haslauer 1992, AS 8793 and 8795.

17 Niwiński 1988, 124 n. 109. Outer coffin, inner coffin and mummy-board. Dating: middle 21st Dynasty (mummy braces of H.P. Pinudjem II).

18 Niwiński 1989, p. 268 n. 44—S.R.IV.981 (JE 95879—Book of the Dead probably enclosed in an Osiris figure, type BD.II.2) and p. 291 n. 107—S.R.VII.10654 (Book of the Amduat between legs, type A.III.1b).

19 Aston 2009, 184–185 TG. 787.

Bibliography

A. Pellegrini, *Bessarione VII* (1899–1900), p. 17 n. 89–90.

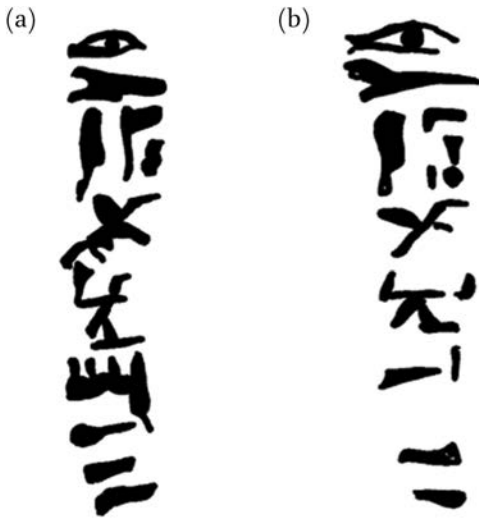

FIGURE 224 Shabtis of Padiamun (Inscriptions)



FIGURE 225 Shabtis of Padiamun

17. Shabtis of Padiamun (*Pꜣ-di-Īmn*)

Inv. NN. 8588 and 8589

Cairo List: 45

Daressy List: A.24

Height: (a) 9 cm; (b) 9,5 cm

Raw Material: Pottery painted light green and varnished.

State of Preservation: Good. The paint and the varnish are nearly lost.

Description

Mummiform servant.

Face crudely shaped with eyes and brows outlined in black.

Ears modeled over the lappets of the tripartite wig (modeled). The wig is adorned with *seshed*-headband.

Arms crossed over the chest grasping the hoes.

Basket on the back.

Iconographic details (headband, hoes and basket) are outlined in black.

Inscription

Painted black. Three columns of hieroglyphs.

“(1) The Osiris, prophet of (2) Amun, Padi(3)amun justified”.

Typology

(a) 4.5.1—Tc: Cl. VIII A1; W 19; H 1; I 5; B 17; Tp 1a (columns, unframed)

(b) 4.5.1—Tc: Cl. VIII A2; W 19; H ?; I 5; B 8; Tp 1a (columns, unframed)

Other examples of this second series of *shabtis* for Padiamun are found in museums in Basel,¹ Brussels,² Cairo,³ Clermont-Ferrand,⁴ Copenhagen,⁵ Cor-

1 Schlögl and Brodbeck 1990, 184 n. 113b.

2 <http://carmentis.kmkg-mrah.be>, E 05442 a–b.

3 Newberry 1957, 287 CG 48040–41.

4 Dautant et al. 2013, Table 1 n. 45.

5 Mogensen 1918, n. 3935–3936.

tona,⁶ Kaunas,⁷ Leiden,⁸ Lisbon,⁹ London,¹⁰ Madrid,¹¹ Marseille,¹² Oslo,¹³ Paris,¹⁴ Roanne,¹⁵ St. Gallen¹⁶ and Wien.¹⁷

Burial Assemblage

These objects belong to the second series of statuettes inscribed with the name Padiamun. These objects are smaller displaying three columns of hieroglyphs.

The coffin set of the “Scribe of the embalming house of Amun” is kept in the Egyptian Museum in Cairo¹⁸ together with his funerary papyrus.¹⁹ The deceased was buried with mummy braces.²⁰

Bibliography

A. Pellegrini, *Bessarione VII* (1899–1900), p. 18 n. 96.

-
- 6 Botti 1955, 72 n. 93.
 7 Berlev and Hodjash 1998, n. 31.
 8 Schneider 1977, n. 4.5.1. 11–12, with traces of green painting and varnish.
 9 Sociedade de Geografia de Lisboa, n. 2507-45 A and B. Araujo 2003, 620–621 n. 26–27. Museu Nacional de Arqueologia, E 89–90. Araujo 2003, 718–719 n. 18–19.
 10 Petrie 1935, n. 14, 15 and 20. http://www.britishmuseum.org/research/collection_online, EA 24873–74.
 11 <http://ceres.mcu.es>, n. 18348–49.
 12 Dautant et al. 2013, Table 1 n. 45.
 13 Naguib 1985, EM 8103 and EM 8113.
 14 Aubert 1998, n. 15 (Louvre E 22149), attests the same traces of green painting and yellow varnish of the same kind than that found on the coffins of the period. The scholar ascribes the statuette to the deceased A.114.
 15 Gabolde 1990, 115 n. 98.
 16 Schlögl and Brodbeck 1990, 183 n. 113a.
 17 Haslauer 1992, AS 6161–6162.
 18 Niwiński 1988, 119 n. 86. Outer coffin, inner coffin and mummy-board. Dating: middle 21st Dynasty (mummy braces of H.P. Pinudjem II and King Amenemope).
 19 Niwiński 1989, 277–278 n. 69—S.R.VII.10232 (Book of the Dead probably enclosed in an Osiris figure, type BD.III.1b).
 20 Aston 2009, 167 TG. 697. The author doesn't make reference to ushebtis for this deceased, while ascribes all the statuettes named Padiamun to the deceased A.114 (see N.Cat. 14).



FIGURE 226 Shabtis of Padiamun
(Inscriptions)



FIGURE 227 Shabtis of Padiamun

18. Shabtis of Meritamun (*Mr.t-Ímn*)

Inv. NN. 8570 and 8571

Cairo List: 8

Daressy List: A.71

Height: (a) 12,2 cm; (b) 12 cm

Raw Material: Blue faience

State of Preservation: Good.

Description

Mummiform servant.

Face poorly shaped with eyes and brows outlined in black.

Ears modeled over the lappets of the tripartite wig (modeled). The wig is adorned with *seshed*-headband.

Arms crossed over the chest grasping the hoes (slightly modeled). Basket on the back.

Iconographic details (headband, hoes and basket) are outlined in black.

Inscription

Painted black. One column of hieroglyphs.

“The Osiris Meritamun, justified”.

Typology

4.3.1—Tc: Cl. VIII A1; W 19; H 1; I 5; B 10; Tp 7b

Other examples of the first type of *shabtis* for Meritamun are found in museums in Amiens,¹ Basel,² Bruxelles,³ Cairo,⁴ Copenhagen,⁵ Leiden,⁶ Lisbon,⁷ London,⁸ Madrid,⁹ Marseille,¹⁰ Oslo,¹¹ Paris,¹² Roanne¹³ and St. Gallen.¹⁴

Burial Assemblage

The “Chantress of Amun”, “Musician of the choir of Mut, great lady of Isheru”, “Nurse of Khonsu, the child” Meritamun, was the daughter of the High Priest Menkheperra and of IsetItemkhebi c.

The lady was buried in a coffin set now in the Egyptian Museum in Cairo¹⁵ together with her funerary papyrus.¹⁶ The funerary equipment included an Osiris shroud, a human-headed scarab, a winged scarab on the chest, a gilded wood embalmer’s plaque, a bronze hawk pectoral, four canopic jars and two *shabti*-boxes.¹⁷

Three different types of *shabtis* can be ascribed to Meritamun, with differences in shape, measurements and in the writing of the name. These are two examples of the first type (see N.Cat. 19 for the second type and N.Cat. 20 for the third). The statuettes are tall and slim with honorific anteposition of the god’s name in the inscription.

Bibliography

A. Pellegrini, Bessarione VII (1899–1900), p. 12 n. 53–54.

-
- 1 Dautant et al. 2013, Table 1 n. 8 (overseer).
 - 2 Schlögl and Brodbeck 1990, 174 n. 106b.
 - 3 <http://carmentis.kmkg-mrah.be>, E 05406 a–b.
 - 4 Newberry 1957, pp. 43–44 CG 46773–78 and p. 52 CG 46849–72.
 - 5 Mogensen 1918, n. 3989–3990.
 - 6 Schneider 1977, n. 4.3.1. 8–9.
 - 7 Sociedade de Geografia de Lisboa, n. 2507-8 A and B. Araujo 2003, 624–625 n. 30–31.
 - 8 Petrie 1935, n. 295. http://www.britishmuseum.org/research/collection_online, EA 24879–80.
 - 9 MAN 18274–75.
 - 10 Dautant et al. 2013, Table 1 n. 8.
 - 11 Naguib 1985, EM 8105 (b) and EM 8112.
 - 12 Louvre E 22086.
 - 13 Gabolde 1990, 100 n. 80.
 - 14 Schlögl and Brodbeck 1990, 173 n. 106.
 - 15 Niwiński 1988, 128 n. 128. Inner coffin and mummy-board. Dating: late 21st Dynasty.
 - 16 Niwiński 1989, 263 n. 31—S.R.IV.933 (JE 95836—Book of the Amduat, type A.II.1b).
 - 17 Aston 2009, 175–176 TG. 744.

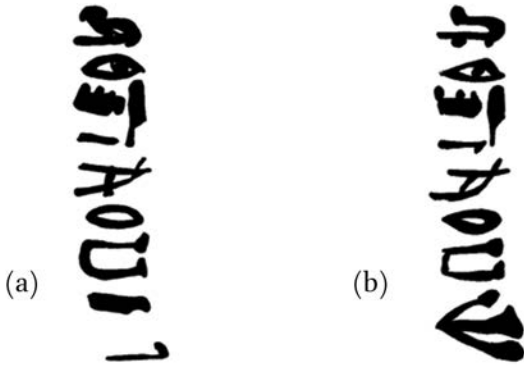

FIGURE 228 Shabtis of Meritamun (Inscriptions)



FIGURE 229 Shabtis of Meritamun

19. Shabtis of Meritamun (*Mr.t-Imn*)

Inv. NN. 8608 and 8609

Cairo List: 14

Daressy List: A.71

Height: 10 cm

Raw Material: Light blue faience

State of Preservation: Good. In (a) the inscription is faded.

Description

Mummiform servant.

Face crudely shaped with eyes and brows outlined in black.

Ears modeled over the lappets of the tripartite wig (modeled). Wig adorned with *sheshed*-headband painted black.

Arms crossed over the chest grasping the hoes (modeled).

Basket on the back.

Iconographic details (headband, hoes and basket) are outlined in black.

Inscription

Painted black. One column of hieroglyphs.

“The Osiris Meritamun, justified”.

Typology

(a) 4.3.1—Tc: Cl. VIII A2; W 19; H 1; I 5; B 10b; Tp 7b

(b) 4.3.1—Tc: Cl. VIII A2; W 19; H 1; I 5; B 12b; Tp 7b

Other examples of the second type of *shabtis* for Meritamun are found in Basel,¹ Brussels,² Cairo,³ Clermont-Ferrand,⁴ Copenhagen,⁵ Leiden,⁶ Lisbon,⁷

1 Schlögl and Brodbeck 1990, 174 n. 106c.

2 <http://carmentis.kmkg-mrah.be>, E 05410 a–b.

3 Newberry 1957, 73–74 CG 47111–47120.

4 Dautant et al. 2013, Table 1 n. 14.

5 Mogensen 1918, n. 3961–3962.

6 Schneider 1977, n. 4.3.1. 6–7.

7 Sociedade de Geografia de Lisboa, n. 2507-14 A and B. Araujo 2003, 626–627 n. 32–33. Museu Nacional de Arqueologia, E 112 and E 486. Araujo 2003, 726–727 n. 26–27.

London,⁸ Madrid,⁹ Paris,¹⁰ Roanne,¹¹ St. Gallen,¹² Stockholm,¹³ Toulouse¹⁴ and Voronezh.¹⁵

Burial Assemblage

These are two examples of the second type of *shabtis* for Meritamun, smaller and thicker than the first series (N. Cat. 18) but displaying the same honorific anteposition in the writing of the name of the owner.

Bibliography

A. Pellegrini, Bessarione VII (1899–1900), p. 12 n. 52.

8 http://www.britishmuseum.org/research/collection_online, EA 24835–36.

9 MAN 18286–87.

10 Aubert 1998 n. 16 (Louvre E 22136).

11 Gabolde 1990, 100–101 n. 81.

12 Schlögl and Brodbeck 1990, 173 n. 106a.

13 <http://collections.smvk.se/carlotta-mhm>, NME 902.

14 Dautant et al. 2013, Table 1 n. 14.

15 Berlev and Hodjash 1998, n. 72.

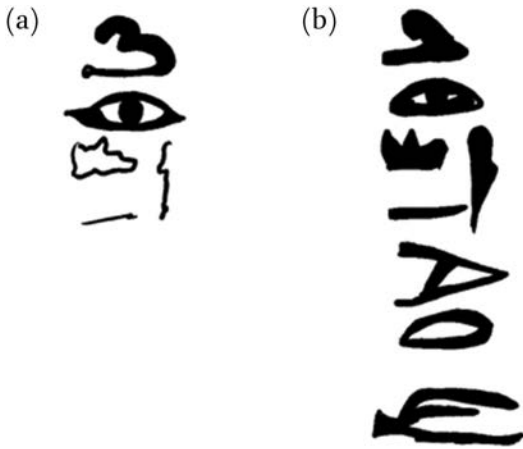

FIGURE 230 Shabtis of Meritamun (Inscriptions)



FIGURE 231 Shabtis of Meritamun

20. Shabtis of Meritamun (*Mr.t-Īmn*)

Inv. NN. 8592 and 8593

Cairo List: 35

Daressy List: A.71

Height: (a) 11,5 cm; (b) 10,6 cm

Raw Material: Blue faience

State of Preservation: Good. The glaze is damaged and the black paint is a little patchy.

Description

Mummiform servant.

Face crudely shaped with eyes and brows outlined in black.

Ears modeled over the lappets of the tripartite wig (modeled and painted black).

Arms crossed over the chest grasping the hoes.

Basket on the back.

Iconographic details (hoes and basket) are outlined in black.

Inscription

Painted black. One column of hieroglyphs bounded by three black lines (two longitudinal lines flanking the inscriptions and a transversal one on top).

“The Osiris Meritamun, justified”.

Typology

4.3.1—Tc: Cl. VIII A2; W 17; H 1; I 5; B 12b; Tp 7c

Other examples of the third type of *shabtis* for Meritamun are found in Berlin,¹ Boulogne-sur-mer,² Brussels,³ Cairo,⁴ Cleveland,⁵ Copenhagen,⁶ Cortona,⁷ Leiden,⁸ Lisbon,⁹ London,¹⁰ Lyon,¹¹ Madrid,¹² Oslo,¹³ Paris¹⁴ and Roanne.¹⁵

Burial Assemblage

These are two examples of the third series of *shabtis* for Meritamun.

The inscription is bounded within black lines and the honorific anteposition in the writing of the name of the owner is not used.

Bibliography

A. Pellegrini, Bessarione VII (1899–1900), pp. 20–21 n. 111–112.

-
- 1 Roeder 1913, n. 11956–57.
 - 2 Dautant et al. 2013, Table 1 n. 35.
 - 3 <http://carmentis.kmkg-mrah.be>, E 05432 a–b.
 - 4 Newberry 1957, 55–56 CG 46923–46932.
 - 5 Berman and Kenneth 1999, 356 n. 267.
 - 6 Mogensen 1918, n. 3985–3986.
 - 7 Botti 1955, 73 n. 114.
 - 8 Schneider 1977, n. 4.3.1. 41–42.
 - 9 Sociedade de Geografia de Lisboa, n. 2507-35 A and B. Araujo 2003, 628–629 n. 34–35.
 - 10 http://www.britishmuseum.org/research/collection_online, EA 24847–48.
 - 11 Dautant et al. 2013, Table 1 n. 35.
 - 12 <http://ceres.mcu.es>, n. 18328–29.
 - 13 Naguib 1985, EM 8083 and EM 8094.
 - 14 Aubert 1998, n. 16 (E 22081).
 - 15 Gabolde 1990, 118–119 n. 101.

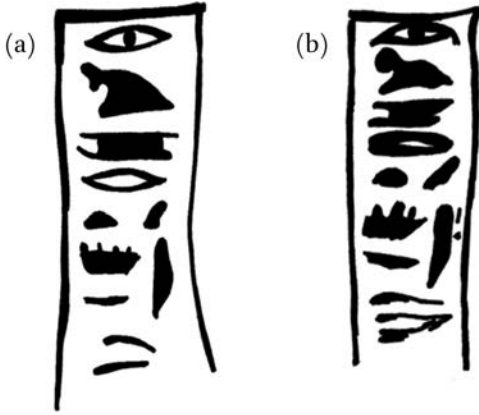

FIGURE 232 Shabtis of Meritamun (Inscriptions)



FIGURE 233 Shabtis of Meritamun

21. Shabtis of Nesiamun (*Ns-Ímn*)

Inv. NN. 8606 and 8607

Cairo List: 38

Daressy List: A.148

Height: (a) 11,8 cm; (b) 11,6 cm

Raw Material: Light blue faience

State of Preservation: Good.

Description

Mummiform servant.

Features of the face correctly moulded, with eyes and brows outlined in black. Ears modeled over the lappets of the tripartite wig (modeled). The wig is adorned with *seshed*-headband.

Arms crossed over the chest grasping the hoes.

Basket on the back.

Iconographic details (hoes and basket) are outlined in black.

Inscription

Outlined in black. In (a) there are three horizontal lines of hieroglyphs, five in (b).

- (a) “(1) The Osiris, fourth prophet (2) of Amun-Re king of the gods, (3) Nesiamun, justified”.
- (b) “(1) The Osiris, fourth prophet of Amun, Nesi(2)amun, justified. He says: oh shabti, (3) if I will be called, if I will be summoned in the Sacred Land, [---]”.

Typology

4.3.1—Tc: Cl. VIII A1; W 19; H 8; I 5; B 12b; Tp 1b

Other examples of *shabtis* for Nesiamun are found in museums in Amiens,¹ Basel,² Berlin,³ Boulogne-sur-mer,⁴ Brussels,⁵ Cairo,⁶ Copenhagen,⁷ Cortona,⁸ Ivanovo,⁹ Leiden,¹⁰ Lisbon,¹¹ London,¹² Madrid,¹³ Oslo,¹⁴ Paris,¹⁵ Roanne,¹⁶ St. Gallen¹⁷ and private collections.¹⁸

Burial Assemblage

Nesiamun had several titles including “Divine father of Amun”, “Chief of the secrets in the sky, on the earth and in the Duat” and “The one who opens the doors of the sky in Karnak”. His coffin set was found in the inner chamber of Bab el-Gasus, together with the coffins of Menkheperra, Gautseshen and Tjanefer. Nevertheless the relationship between Nesiamun and the High Priest of Amun is unknown.

The coffins of Nesiamun are kept in the Egyptian Museum in Cairo¹⁹ together with his funerary papyrus.²⁰ The burial assemblage included an Osiris shroud, mummy braces, floral garlands, a green stone scarab, a granite heart amulet, a copper embalmer’s plaque, a small collection of amulets and two *shabti*-boxes.

The funerary statuettes show from three to five horizontal bands of hieroglyphic inscription and the title of “Fourth prophet of Amun”, but we know that

1 Dautant et al. 2013, Table 1 n. 38.

2 Schlögl and Brodbeck 1990, 171 n. 104a (three horizontal lines).

3 BM 11955.

4 Dautant et al. 2013, Table 1 n. 38.

5 <http://carmentis.kmkg-mrah.be>, E 05435 a (four horizontal lines) and b.

6 Newberry 1957, 61–64 CG 46981–47000.

7 Mogensen 1918, n. 3953–3954 (three horizontal lines).

8 Botti 1955, 73 n. 83 (three horizontal lines).

9 Berlev and Hodjash 1998, n. 30.

10 Schneider 1977, n. 4.3.1. 43–44.

11 Sociedade de Geografia de Lisboa, n. 2507–38 A (four horizontal lines) and B (three horizontal lines). Araujo 2003, 630–633 n. 36–37.

12 http://www.britishmuseum.org/research/collection_online, EA 24833 (three horizontal lines) and 24834 (overseer).

13 <http://ceres.mcu.es>, n. 18334–35 (three horizontal lines).

14 Naguib 1985, EM 8086 and EM 8092 (three horizontal lines).

15 Aubert 1998, n. 19.

16 Gabolde 1990, 120 n. 103 (three horizontal lines).

17 Schlögl and Brodbeck 1990, 170 n. 104 (three horizontal lines).

18 Janes 2002, 92–93 n. 46 (three horizontal lines).

19 Niwiński 1988, 118 n. 79. Outer coffin, inner coffin and mummy-board. Dating: late 21st Dynasty (mummy braces of H.P. Psusennes).

20 Niwiński 1989, 272 n. 55—S.R.IV.1535 (Book of the Amduat between legs, type A.II.1a).

after the manufacturing of these objects Nesiamun became “Third prophet of Amun” (as seen on his funerary papyrus).

Bibliography

A. Pellegrini, *Bessarione VII* (1899–1900), p. 32 n. 191–192.

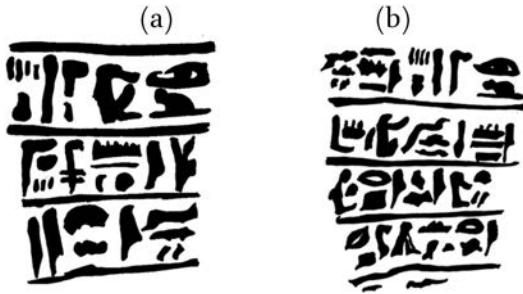

FIGURE 234 Shabtis of Nesiamun (Inscriptions)



FIGURE 235 Shabtis of Nesi'amun

22. Shabtis of Nesiamenemope (*Ns-Īmn-m-ipt*)

Inv. NN. 8598 and 8599

Cairo List: 31

Daressy List: A.113

Height: (a) 8,6 cm; (b) 8,5 cm

Raw Material: Red pottery painted white.

State of Preservation: (a) Quite good. The black paint used to outline the main motifs and inscriptions has faded away, especially in the upper part of the object.

(b) Good. The white paint has faded away.

Description

Mummiform servant.

Face poorly shaped with eyes and brows painted black.

Ears modeled over the lappets of the tripartite wig, modeled and painted blue in (b). The wig is adorned with a *seshed*-headband.

Arms crossed over the chest grasping the hoes.

Big basket on the back.

Iconographic details (headband, hoes and basket) are outlined in black.

On the back of the statuettes fingerprints are detected revealing how these objects were crafted: the clay was pressed into the mould before being dried.

Inscription

Painted black. One column of hieroglyphs.

“That may shine the Osiris, *wab*-priest, *imi-seta*¹ in the Estate of Amun, Nesiamenemope justified”.

Typology

(a) 4.5.1—Tc: Cl. VIII1A1; w 19; H 8 (?); I 5; B 12b; Tp 7b

(b) 4.5.1—Tc: Cl. VIII1A1; w 20; H 8; I 5; B 12b; Tp 7b

1 WB I, 75.

Other examples of *shabtis* for Nesiamenemope are found in museums in Amiens,² Basel,³ Berlin,⁴ Brussels,⁵ Cairo,⁶ Copenhagen,⁷ Kiev,⁸ Leiden,⁹ Lisbon,¹⁰ London,¹¹ Madrid,¹² Marseille,¹³ Paris,¹⁴ Roanne,¹⁵ St. Gallen,¹⁶ Stockholm,¹⁷ Uppsala,¹⁸ Wien,¹⁹ Zurich²⁰ and private collections.²¹

Burial Assemblage

Nesiamenemope was buried in a coffin set (usurped from Imiseba) now in the Egyptian Museum in Cairo²² together with his funerary papyri.²³ He was “*wab*-priest at the prow of Amun”, “great *wab*-priest assigned to the service of Amun in Karnak”, “*imi-seta*” and “Scribe of the treasury of the Estate of Amun”. The funerary equipment was composed of an Osiris shroud, three pairs of mummy braces, a feldspar scarab, a wax embalmer’s plaque and two *shabti*-boxes.²⁴

Bibliography

A. Pellegrini, *Bessarione VII* (1899–1900), p. 23 n. 131.

-
- 2 Dautant et al. 2013, Table 1 n. 31.
 3 Schlögl and Brodbeck 1990, 206 n. 128b.
 4 Roeder 1913, n. 11952–53.
 5 <http://carmentis.kmkg-mrah.be>, E 05428 a–b.
 6 Newberry 1957, 284–285 CG 48004–48013.
 7 Mogensen 1918, n. 3923–3924.
 8 Berlev and Hodjash 1998, n. 84–85.
 9 Schneider 1977, n. 4.5.1. 15–16.
 10 Sociedade de Geografia de Lisboa, n. 2507-31 A and B. Araujo 2003, 634–635 n. 38–39.
 11 http://www.britishmuseum.org/research/collection_online, EA 24891–92.
 12 <http://ceres.mcu.es>, n. 18321.
 13 Dautant et al. 2013, Table 1 n. 31 (overseer).
 14 Aubert 1998, n. 20.
 15 Gabolde 1990, 120–121 n. 104.
 16 Schlögl and Brodbeck 1990, 206 n. 128a.
 17 <http://collections.smvk.se/carlotta-mhm>, NME 914.
 18 Sandman 1931, 98 n. 10.
 19 Haslauer 1992, AS 6179.
 20 Schlögl and Brodbeck 1990, 205 n. 128.
 21 Janes 2002, 93–94 n. 47.
 22 Niwiński 1988, 123 n. 102. Outer coffin, inner coffin and mummy-board. Dating: middle 21st Dynasty (mummy braces of King Amenemope, H.P. Pinudjem II and H.P. Menkheperre).
 23 Niwiński 1989, p. 282 n. 82—S.R.VII.10245 (Book of the Amduat at side, type A.II.1b) and p. 288 n. 98—S.R.VII.10269 (Book of the Dead probably enclosed in an Osiris figure, type BD.II.1).
 24 Aston 2009, 184 TG. 786.

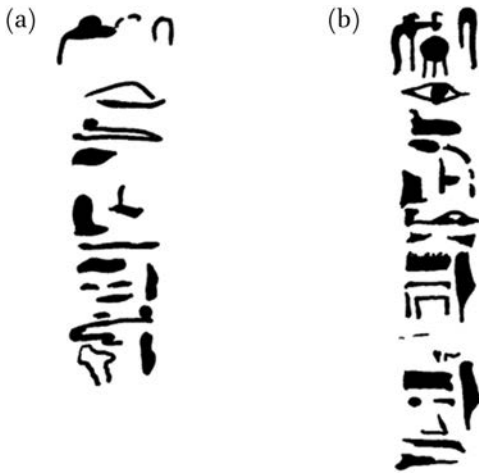

FIGURE 236 Shabtis of Nesiamenemope
(Inscriptions)



FIGURE 237 Shabtis of Nesiamenemope

23. Shabtis of Nesipaheran (*Ns-pꜣ-ḥr-ꜥn*)

Inv. NN. 8584 and 8585

Cairo List: 46

Daressy List: A.35

Height: (a) 10,4 cm; (b) 10,5 cm

Raw Material: Light blue faience

State of Preservation: Good. In (a) the glaze is eroded on the face.

Description

Mummiform servant.

Face crudely shaped with eyes and brows outlined in black.

Ears modeled over the lappets of the tripartite wig (modeled). The wig is adorned with *sheshed*-headband.

Arms crossed over the chest grasping the hoes. Basket on the back.

Iconographic details (headband, hoes and basket) are outlined in black.

Inscription

Painted black. One column of hieroglyphs.

“The Osiris Nesipaheran”

Typology

4.3.1—Tc: Cl. VIII A2; W 19; H ?; I 5; B 12b; Tp 7b

Other examples of *shabtis* for Nesipaheran are found in museums in Basel,¹ Berlin,² Brussels,³ Cairo,⁴ Copenhagen,⁵ Cortona,⁶ Kiev,⁷ Leiden,⁸ Lisbon,⁹ Lon-

1 Schlögl and Brodbeck 1990, 176 n. 108a.

2 Roeder 1913, n. 11975 (two examples).

3 <http://carmentis.kmkg-mrah.be>, E 05443 a–b and E 05445.

4 Newberry 1957, 57–58 CG 46938–46946.

5 Mogensen 1918, n. 3997–3998.

6 Botti 1955, 73 n. 92.

7 Berlev and Hodjash 1998, n. 88–89.

8 Schneider 1977, n. 4.3.1. 48–49.

9 Sociedade de Geografia de Lisboa, n. 2507-46 A and B. Araujo 2003, 636–637 n. 40–41. Museu Nacional de Arqueologia, E 107–109 and E 456–457. Araujo 2003, 728–732 n. 28–32.

don,¹⁰ Madrid,¹¹ Marseille,¹² Oslo,¹³ Paris,¹⁴ Roanne,¹⁵ St. Gallen¹⁶ and private collections.¹⁷

Burial Assemblage

The deceased from A.35 had the titles of divine father of Amun, *wab*-priest of Khonsu and scribe of the Estate of Amun. His coffin set is in the Suez Museum,¹⁸ while his funerary papyrus is in Oxford.¹⁹ Nesipaheran was buried with an Osiris shroud and two *shabti*-boxes.²⁰

Bibliography

A. Pellegrini, Bessarione VII (1899–1900), p. 24 n. 137.

10 Petrie 1935, n. 276. http://www.britishmuseum.org/research/collection_online, EA 24867–68.

11 MAN 18350–51.

12 Dautant et al. 2013, Table 1 n. 46.

13 Naguib 1985, EM 8098 and EM 8115.

14 Louvre E 22078.

15 Gabolde 1990, 123 n. 106.

16 Schlögl and Brodbeck 1990, 176 n. 108.

17 Aubert 1998, n. 22.

18 Niwiński 1988, 169–170 n. 367. Outer coffin, inner coffin and mummy-board. Dating: 21st Dynasty.

19 Bodleian Library, Papyrus Skine n. 2.

20 Aston 2009, 169 TG. 708.

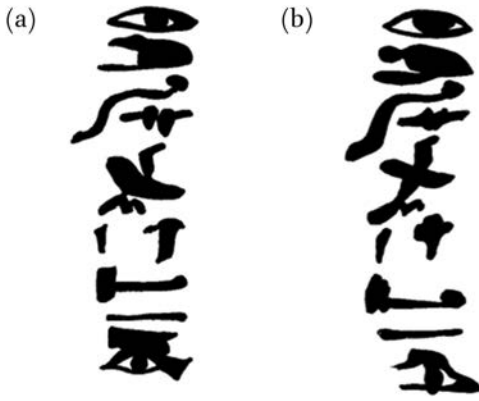

FIGURE 238 Shabtis of Nesipaheran (Inscriptions)



FIGURE 239 Shabtis of Nesipaheran

24. Shabtis of Nesipahernefer (*Ns-pꜣ-hr-nfr*)

Inv. NN. 8568 and 8569

Cairo List: 43

Daressy List: A.98

Height: (a) 11,5 cm; (b) 11,4 cm

Raw Material: Blue faience

State of Preservation: Good.

Description

Mummiform servant.

Face poorly shaped with eyes and brows outlined in black.

Ears modeled over the lappets of the tripartite wig (striated and modeled). The wig is adorned with a *seshed*-headband.

Arms crossed over the chest grasping the hoes.

Basket on the back.

Iconographic details (headband, hoes and basket) are outlined in black.

Inscription

Painted black. One column of hieroglyphs.

- (a) “That may shine the Osiris, chief of the recruits of the Estate of Amun, Nesipahernefer”.
- (b) “That may shine the Osiris, divine father beloved of Amun, Nesipahernefer”.

Typology

4.3.1—Tc: Cl. VIII A2; W 24; H 1; I 5; B 14; Tp 7b

Other examples of *shabtis* for Nesipahernefer are found in museums in Basel,¹ Berlin,² Brussels,³ Cairo,⁴ Clermont-Ferrand,⁵ Copenhagen,⁶ Cortona,⁷ Leiden,⁸

1 Schlögl and Brodbeck 1990, 195 n. 119b.

2 Roeder 1913, n. 11894–95.

3 <http://carmentis.kmkg-mrah.be>, E 05440 a–b.

4 Newberry 1957, 66–68 CG 47031–47049.

5 Dautant et al. 2013, Table 1 n. 43.

6 Mogensen 1918, n. 3973–3974.

7 Botti 1955, 73 n. 123.

8 Schneider 1977, n. 4.3.1. 50–51.

Lisbon,⁹ London,¹⁰ Lyon,¹¹ Madrid,¹² Paris,¹³ Roanne,¹⁴ St. Gallen,¹⁵ Stockholm,¹⁶ Voronezh,¹⁷ Wien¹⁸ and private collections.¹⁹

Burial Assemblage

Nesipahernefer was “Prophet and divine father beloved of Amun”, “Divine father of Mut”, “Scribe and chief of the recruits of the Estate of Amun”. He was buried in a coffin set (usurped from Harhotep) whose location is currently unknown.²⁰ His funerary papyri are in the Egyptian Museum in Cairo.²¹ The burial assemblage included an Osiris shroud, a green basalt scarab, a bronze hawk-shaped pectoral, mummy braces, a wax embalmer’s plaque and two *shabti*-boxes.²² A magical papyrus was left on the chest.²³

Daressy ascribes all the statuettes named Nesipahernefer to the deceased A.117, the analysis of those objects suggests that these statuettes are to be ascribed to the homonim deceased from A.98.

Bibliography

Unpublished.

-
- 9 Sociedade de Geografia de Lisboa, n. 2507-43 A and B. Araujo 2003, 638–639 n. 42–43.
 10 http://www.britishmuseum.org/research/collection_online, EA 24875–76.
 11 Dautant et al. 2013, Table 1 n. 43.
 12 <http://ceres.mcu.es>, n. 18344–45.
 13 Aubert 1998, n. 21.
 14 Gabolde 1990, 121–122 n. 105.
 15 Schlögl and Brodbeck 1990, 195 n. 119a.
 16 <http://collections.smvk.se/carlotta-mhm>, NME 897.
 17 Berlev and Hodjash 1998, n. 73.
 18 Haslauer 1992, AS 8797 (?).
 19 Janes 2002, 97–98 n. 49.
 20 Niwiński 1988, 201.
 21 Niwiński 1989, p. 276 n. 66—S.R.VII.10229 (Book of the Amduat between legs, type A.II.1a) and p. 298 n. 125—S.R.VII.11503 (Book of the Dead probably enclosed in an Osiris figure, type BD.III.1a).
 22 Aston 2009, 180–181 TG. 771.
 23 Niwiński 1989, 301 n. CAIRO D—S.R.IV.941 (JE 95843—Magical papyrus, type U).

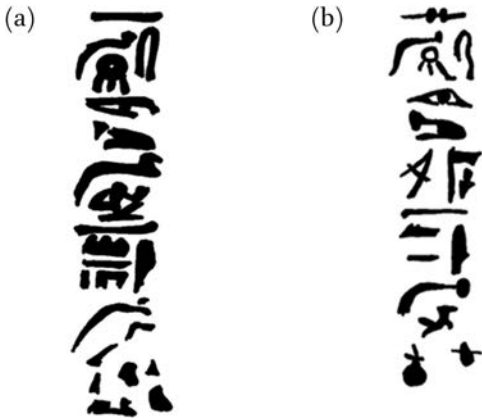

FIGURE 240 Shabtis of Nesipahermefer (Inscriptions)



FIGURE 241 Shabtis of Nesipahermefer

25. Shabtis of Nesipakashuti (*Ns-pꜣ-kꜣ-šw.ti*)

Inv. NN. 8590 and 8591

Cairo List: 25

Daressy List: A.43

Height: (a) 12 cm; (b) 12,2 cm

Raw Material: Light blue faience

State of Preservation: Good. The inscriptions are faint.

Description

(a) Mummiform servant.

Face crudely shaped with eyes and brows outlined in black.

Ears slightly modeled over the lappets of the tripartite wig (modeled and painted black).

Arms crossed over the chest grasping the hoes (now disappeared but once outlined in black).

(b) Overseer.

Face crudely shaped with eyes and brows outlined in black.

Ears slightly modeled over the lappets of the wig (modeled and painted black).

Arms crossed over the chest grasping the whips (now disappeared but once outlined in black).

Inscription

Painted black. One column of hieroglyphs.

“The Osiris, divine father of Amun, Nesipakashuti”.

Typology

(a) 4.3.1—Tc: Cl. VIII A1; W 17; H 1; I 5; B ?; Tp 7b

(b) 4.3.5—Tc: Cl. IX B; W 17; H 1; I ?; B /; Tp 7b

Other examples of mummiform *shabtis* for Nesipakhashuti are found in museums in Berlin,¹ Brussels,² Cairo,³ Clermont-Ferrand,⁴ Copenhagen,⁵ Leiden,⁶ Lisbon,⁷ London,⁸ Madrid,⁹ Paris,¹⁰ Prague, Roanne,¹¹ Uppsala,¹² Warsaw,¹³ Wien¹⁴ and private collections.¹⁵

Burial Assemblage

The “Divine father of Amun-Re” and “Overseer of the treasury of the supreme chief of the concubines of Amun” was buried in a coffin set now in the Egyptian Museum in Cairo¹⁶ together with his funerary papyri.¹⁷ The burial assemblage includes an Osiris shroud, three pink serviettes around the body, a blue glaze heart scarab, pendeloques, wax coated clay Sons of Horus (found inside the body), blue glaze amulets, wax embalmer’s plaque and a *shabti*-box.¹⁸

Bibliography

Unpublished.

-
- 1 Roeder 1913, n. 11969.
 - 2 <http://carmentis.kmkg-mrah.be, E 05422>.
 - 3 Newberry 1957, 238 CG 47783.
 - 4 Dautant et al. 2013, Table 1 n. 25.
 - 5 Mogensen 1918, n. 4005.
 - 6 Schneider 1977, n. 4.3.1. 52–53.
 - 7 Sociedade de Geografia de Lisboa, n. 2507-25 A. Araujo 2003, 640 n. 44.
 - 8 Petrie 1935, n. 365, 391–392 and 395.
 - 9 MAN 18308–09.
 - 10 Louvre E 22114.
 - 11 Gabolde 1990, 124 n. 107.
 - 12 Sandman 1931, 102 n. 20–21.
 - 13 Pomorska 1959, 126–128 n. 45–49.
 - 14 Haslauer 1992, AS 6214.
 - 15 Janes 2002, 100–101 n. 51; Aubert 1998, n. 23.
 - 16 Niwiński 1988, 121 n. 94. Outer coffin, inner coffin and mummy-board. Dating: late 21st Dynasty (mummy braces of H.P. Psusennes).
 - 17 Niwiński 1989, p. 270 n. 48—S.R.IV.994 (JE 95889—Book of the Dead probably enclosed in an Osiris figure, type BD.III.1b) and p. 289 n. 101—S.R.VII.10272 (Book of the Amduat between legs, type A.II.1a).
 - 18 Aston 2009, 171–172 TG. 716.

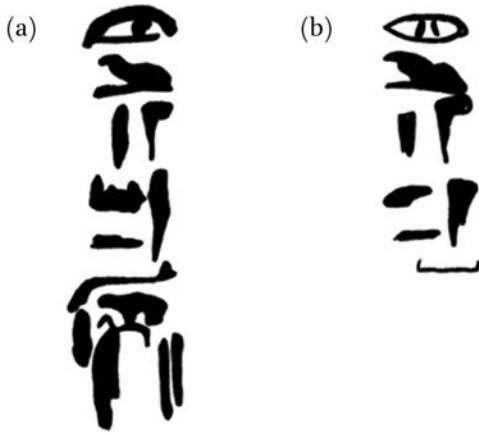

FIGURE 242 Shabtis of Nesipakashuti (Inscriptions)



FIGURE 243 Shabtis of Nesipakashuti

26. Shabtis of Nesimut (*Ns-Mwt*)

Inv. NN. 8538 and 8539

Cairo List: 32

Daressy List: A.48 and A.54 (?)

Height: (a) 14 cm; (b) 13,5 cm

Raw Material: Grey pottery, once painted pale green.

State of Preservation: Good. In (a) the paint is lost and there is a little hole on the back. In (b) the paint is lost and there are cracks on the chin and on the right lappet. There is a square hole on the legs and a break has been repaired in the lower part.

Description

Mummiform servant.

Features of the face poorly shaped with eyes and brows outlined in black.

Ears slightly modeled over the lappets of the tripartite wig (modeled). The wig is adorned with *sheshed*-headband.

In (a) the breasts are modeled below the lappets. Arms crossed over the chest grasping the hoes.

Basket on the back. Iconographic details (headband, hoes and basket) are outlined in black.

Inscription

Painted black. One column of hieroglyphs.

“That may shine the Osiris Nesimut”.

Typology

(a) 4-5.1—Tc: Cl. VIIIIB1; W 19; H 8; I 5; B 12b; Tp 7b

(b) 4-5.1—Tc: Cl. VIIIA1; W 19; H 1; I 5; B 12b; Tp 7b

Female characters can be detected on the *shabtis* for Nesimut found in Museums in Basel,¹ Lisbon² and Stockholm.³

1 Schlögl and Brodbeck 1990, 199 n. 123a.

2 Sociedade de Geografia de Lisboa, n. 2507-32 A. Araujo 2003, 641 n. 45.

3 <http://collections.smvk.se/carlotta-mhm>, MM 14989.

Examples of the male *shabtis* for Nesimut are found in museums in Brussels,⁴ Clermont-Ferrand,⁵ Leiden,⁶ Lisbon,⁷ London,⁸ Paris,⁹ Roanne¹⁰ and Uppsala.¹¹ Other examples of *shabtis* for Nesimut are found in museums in Copenhagen,¹² Cortona¹³ and St. Gallen.¹⁴

Burial Assemblage

At least two individuals named Nesimut seem to have been buried in Bab el-Gasus.

The coffin set of the “Chantress of Amun” Nesymut (A.48) is shared between Odessa and Cairo museums.¹⁵ The woman was buried with mummy braces, three serviettes, two pairs of linen mittens, a schist heart scarab, wax figurines of the Sons of Horus (inside the body) and two *shabti*-boxes.¹⁶

Nevertheless the name Nesimut can be read on a male outer coffin belonging to an anonymous coffin set preserved in Neuchatel (A.54).¹⁷

Perhaps not hazardously, two types of *shabtis* could be assigned to two different burial assemblages. The first type (a) shows big head, female features and a short version of the name Nes(i)mut. So we can match this kind of statuette with the deceased from A.48. The second example (b) is more proportionate and shows a full writing of the name Nesimut. Furthermore, a hole (maybe a fault in the mold) can be detected in the lower part corresponding to the knees. We can attribute this male example to the deceased from A.54.

Bibliography

Unpublished.

-
- 4 <http://carmentis.knkg-mrah.be>, E 05429 a–b.
 5 Dautant et al. 2013, Table 1 n. 32.
 6 Schneider 1977, n. 4.5.1. 17–18.
 7 Sociedade de Geografia de Lisboa, n. 2507-32 B. Araujo 2003, 642 n. 46.
 8 Petrie 1935, UC 443. http://www.britishmuseum.org/research/collection_online, EA 24885–86.
 9 Aubert 1998, n. 25 (Louvre E 20245).
 10 Gabolde 1990, 125 n. 108.
 11 Sandman 1931, 102 n. 19.
 12 Mogensen 1918, n. a.a.a. 101.
 13 Botti 1955, p. 74 n. 84.
 14 Schlögl and Brodbeck 1990, 199 n. 123.
 15 Niwiński 1988, pp. 120–121 n. 91 and p. 162 n. 318. Inner coffin and mummy-board. Dating: middle/late 21st Dynasty (mummy braces of H.P. Psusennes).
 16 Aston 2009, 173 TG. 721.
 17 Niwiński 1988, 158 n. 299. Outer coffin, inner coffin and mummy-board. Dating: late 21st Dynasty.

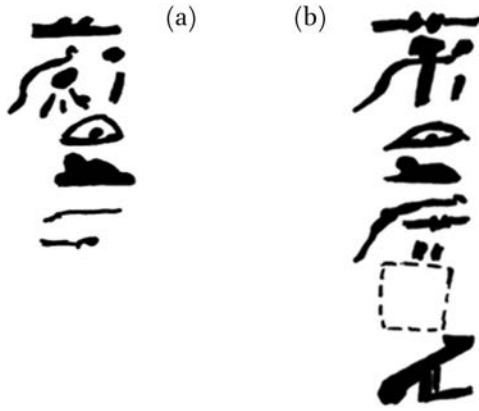

FIGURE 244 Shabtis of Nesimut (Inscriptions)



FIGURE 245 Shabtis of Nesimut

27. Shabtis of Nesikhonsu (*Ns-ḥnsw*)

Inv. NN. 8554 and 8556

Cairo List: 44

Daressy List: A.42

Height: (a) 9 cm; (b) 9,5 cm

Raw Material: Pottery painted white.

State of Preservation: Good. The paint is partially lost. In (b) the inscription is completely faded.

Description

Mummiform servant.

Face relatively well shaped with eyes and brows outlined in black.

Ears modeled over the lappets of the tripartite wig (modeled and painted black).

In (a) the breasts are modeled below the lappets.

Arms crossed over the chest grasping the hoes.

Basket on the back.

Iconographic details (hoes and basket) are outlined in black.

Inscription

Painted black. One column of hieroglyphs.

“The Osiris Nesikhonsu, justified”.

Typology

(a) 4.5.1—Tc: Cl. VIII B1; W 17; H 8; I 5; B 13b; Tp 7b

(b) 4.5.1—Tc: Cl. VIII A2; W 17; H 1; I 5; B 13b; Tp 7b

Other examples of *shabtis* for Nesikhonsu are found in museums in Amiens,¹ Basel,² Berlin,³ Brussels,⁴ Cairo,⁵ Copenhagen,⁶ Leiden,⁷ Lisbon,⁸ London,⁹ Madrid,¹⁰ Oslo,¹¹ Paris,¹² Roanne,¹³ St. Gallen¹⁴ and Voronezh.¹⁵

Burial Assemblage

The coffin set of the “Chantress of Amun” Nesikhonsu is currently dispersed. Some objects are kept in the Egyptian Museum in Cairo while others are in the Archaeological Museum in Istanbul.¹⁶ Her funerary papyrus is in the Luxor Mummification Museum.¹⁷ Osiris shroud, mummy braces and a *shabti*-box were part of the funerary equipment.¹⁸

Bibliography

A. Pellegrini, *Bessarione VII* (1899–1900), p. 24 n. 136.

-
- 1 Dautant et al. 2013, Table 1 n. 44.
 - 2 Schlögl and Brodbeck 1990, 196 n. 120a.
 - 3 Roeder 1913, n. 11902 (two examples).
 - 4 <http://carmentis.kmkg-mrah.be>, E 05441 a–b.
 - 5 Newberry 1957, 285–286 CG 48014–48023.
 - 6 Mogensen 1918, n. 3927–3928.
 - 7 Schneider 1977, n. 4.5.1. 19–20.
 - 8 Sociedade de Geografia de Lisboa, n. 2507-44 A and B. Araujo 2003, 643–644 n. 47–48.
 - 9 http://www.britishmuseum.org/research/collection_online, EA 24889–90.
 - 10 MAN 18346–47.
 - 11 Naguib 1985, EM 8105(a) and EM 8122.
 - 12 Aubert 1998, n. 26 (E 22054).
 - 13 Gabolde 1990, 126 n. 109.
 - 14 Schlögl and Brodbeck 1990, 196 n. 120.
 - 15 Berlev and Hodjash 1998, n. 80.
 - 16 Niwiński 1988, 120 n. 90. Outer coffin, inner coffin and mummy-board. Dating: middle/late 21st Dynasty.
 - 17 Niwiński 1989, 341 n. LUXOR 2—J.25 (Book of the Amduat between legs, type A.III.1B).
 - 18 Aston 2009, 171 TG. 715.



FIGURE 246 Shabtis of Nesikhonsu (Inscriptions)



FIGURE 247 Shabtis of Nesikhonsu

28. Shabtis of Nesitaudjatakhet (*Ns-t3-wd3.t-3ht*)

Inv. NN. 8600, 8601 and 8620

Cairo List: 19

Daressy List: A.96

Height: (a) 10,5 cm; (b) 10,2 cm; (c) 6 cm

Raw Material: Blue faience

State of Preservation: Good. The glaze is damaged. In (c) a break has been repaired in the lower part.

Description

Mummiform servant (a and b).

Face crudely modeled with eyes and brows outlined in black. Breasts modeled below the lappets of the tripartite wig (modeled). Wig adorned with *seshed*-headband. Arms crossed over the chest grasping the hoes. Basket on the back.

Overseer (c).

Face crudely modeled. Brows painted black. Tripartite wig with modeled lappets. Wig adorned with *seshed*-headband. Right arm crossed over the chest grasping the hoe and the left arm extended along the body. Long kilt carved in high relief. Iconographic details (headband, hoes and basket) are outlined in black.

Inscription

Painted black. In (a) and (b) the column of hieroglyphs is framed by three black lines (one horizontal in the upper part and two vertical at the sides). In (c) the frame lacks.

(a) “The Osiris Nesitaudjatakhet, justified”.

(b) “The Osiris Nesitaudjat”.

(c) “The Osiris Nesiudjatakhet”.

Typology

(a) 4.3.1—Tc: Cl. VIII B1; W 19; H ?; I 5; B 12b; Tp 7c

(b) 4.3.1—Tc: Cl. VIII B1; W 19; H ?; I 5; B 12b; Tp 7c

(c) 4.3.5—Tc: Cl. IX A; W 20 (?); H 34; I 5; B /; Tp 7b

Other examples of *shabtis* for Nesitaudjatakhet are found in museums in Basel,¹ Brussels,² Cairo,³ Clermont-Ferrand,⁴ Copenhagen,⁵ Leiden,⁶ Lisbon,⁷ London,⁸ Madrid,⁹ Paris,¹⁰ Roanne,¹¹ St. Gallen¹² and Stockholm.¹³

Burial Assemblage

This “Chantress of Amun” was buried in a coffin now in the Archaeological Museum in Odessa.¹⁴ Her funerary papyrus is in the Egyptian Museum in Cairo.¹⁵ The funerary equipment comprised bandage epigraph, a wax embalmer’s plaque and a *shabti*-box.¹⁶

There are little differences in the writing of the name among the various objects of the funerary equipment. We can find the writing “Nesitaudjatakhet”, “Nesiudjat”, “Taudjat” or simply “Udjat”.¹⁷

Bibliography

A. Pellegrini, *Bessarione VII* (1899–1900), p. 15 n. 81.

-
- 1 Schlögl and Brodbeck 1990, 214 n. 137.
 - 2 <http://carmentis.kmkg-mrah.be>, E 05415.
 - 3 Newberry 1957, 58–61 CG 46947–46980 and 48305.
 - 4 Dautant et al. 2013, Table 1 n. 19.
 - 5 Mogensen 1918, n. 3993–3994.
 - 6 Schneider 1977, n. 4.3.1. 54–55.
 - 7 Sociedade de Geografia de Lisboa, n. 2507-9 A and B. Araujo 2003, 645–646 n. 49–50.
 - 8 Petrie 1935, n. 302. http://www.britishmuseum.org/research/collection_online, EA 24883–84.
 - 9 MAN 18296–97.
 - 10 Aubert 1998, n. 27 (E 22128).
 - 11 Gabolde 1990, 126–128 n. 110–111.
 - 12 Schlögl and Brodbeck 1990, 204 n. 127.
 - 13 <http://collections.smvk.se/carlotta-mhm>, NME 901.
 - 14 Niwiński 1988, 161–162 n. 317. Outer and inner coffin. Dating: middle 21st Dynasty (mummy braces of H.P. Menkheperre).
 - 15 Niwiński 1989, p. 260 n. 21—S.R.IV.558 (JE 95660—Book of the Amduat, type A.III.1b) or p. 296 n. 119—S.R.VII.11497 (Book of the Amduat, type A.III.1b).
 - 16 Aston 2009, 180 TG. 769.
 - 17 Araujo 2003, 413.

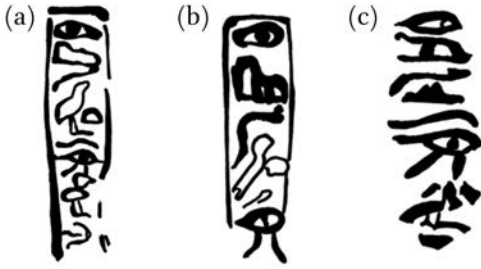

FIGURE 248 Shabtis of Nesitaudjatakhet
(Inscriptions)



FIGURE 249 Shabtis of Nesitaudjatakhet

29. Shabtis of Nesitanebtaui (*Ns-t3-nb(.t)-t3.wy*)

Inv. NN. 8576 and 8577

Cairo List: 2

Daressy List: A.77

Height: (a) 9,7 cm; (b) 9,6 cm

Raw Material: Light blue faience

State of Preservation: Good. In (a) a break has been repaired in the lower part.

Description

Mummiform servant.

Face poorly shaped with eyes and brows outlined in black.

Ears modeled over the lappets of the tripartite wig (modeled and striated).

In (b) the breasts are modeled below the lappets.

Arms crossed over the chest grasping the hoes.

Basket on the back.

Iconographic details (striped wig, hoes and basket) are outlined in black.

Inscription

Painted black. One column of hieroglyphs.

“That may shine the Osiris Nesitanebtaui”.

Typology

4.3.1—Tc: Cl. VIII B1; W 21; H 8; I 15; B 12b; Tp 7b

Other examples of *shabtis* for Nesitanebtaui are found in museums in Basel,¹ Berlin,² Brussels,³ Cairo,⁴ Copenhagen,⁵ Cortona,⁶ Leiden,⁷ Lisbon,⁸ London,⁹ Lyon,¹⁰ Madrid,¹¹ Oslo,¹² Paris,¹³ Roanne,¹⁴ St. Gallen¹⁵ and private collections.¹⁶

Burial Assemblage

The coffin set of the “Chantress of Amun” Nesitanebtaui is in the Egyptian Museum in Cairo¹⁷ together with her funerary papyri.¹⁸ The deceased was buried with a magical papyrus on the chest, floral garlands, Osiris shroud, mummy braces, pendeloques, a blue glaze scarab, a wax embalmer’s plaque and two *shabti*-boxes.¹⁹

Bibliography

Unpublished.

-
- 1 Schlögl and Brodbeck 1990, 175 n. 107a.
 - 2 Roeder 1913, n. 11959.
 - 3 <http://carmentis.kmkg-mrah.be>, E 05401 a–b.
 - 4 Newberry 1957, 54–55 CG 46893–46992.
 - 5 Mogensen 1918, n. 3969.
 - 6 Botti 1955, 75 n. 115.
 - 7 Schneider 1977, n. 4.3.1. 56–57–58.
 - 8 Sociedade de Geografia de Lisboa, n. 2507-2 A and B. Araujo 2003, 647–648 n. 51–52.
 - 9 Petrie 1935, UC 293. http://www.britishmuseum.org/research/collection_online, EA 24871 and 24872 (overseer).
 - 10 Dautant et al. 2013, Table 1 n. 2 (overseer).
 - 11 <http://ceres.mcu.es>, n. 18262–63.
 - 12 Naguib 1985, EM 8100 and EM 8120.
 - 13 Louvre E 22080 and E 22104.
 - 14 Gabolde 1990, 128–129 n. 112.
 - 15 Schlögl and Brodbeck 1990, 175 n. 107.
 - 16 Janes 2002, 110–111 n. 55; Aubert 1998, n. 28.
 - 17 Niwiński 1988, 127 n. 121. Outer coffin, inner coffin and mummy-board. Dating: middle 21st Dynasty.
 - 18 Niwiński 1989, 298–299 n. 126—S.R.VII.11504 (Book of the Dead probably enclosed in an Osiris figure, type BD.III.1a).
 - 19 Aston 2009, pp. 176–177 TG. 750.

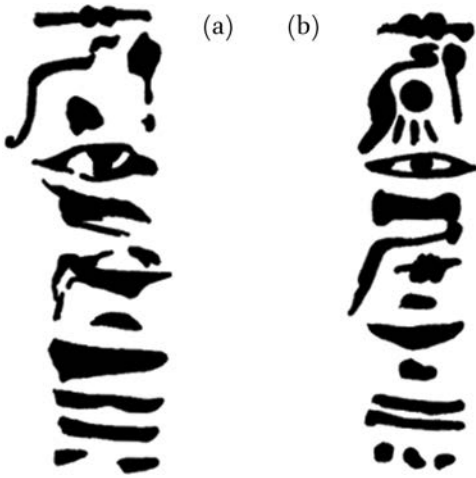

FIGURE 250 Shabtis of Nesitanebtau (Inscriptions)



FIGURE 251 Shabtis of Nesitanebtau

30. Shabtis of Henuttaui (*hnmw.t-t3.wy*)

Inv. NN. 8544 and 8545

Cairo List: 29

Daressy List: A.64

Height: (a) 9,3 cm; (b) 12,3 cm

Raw Material: Light blue faience

State of Preservation: Good. In (b) the inscription is faint and a break has been repaired in the lower part.

Description

- (a) Mummiform servant. Face crudely shaped with eyes and brows outlined in black. Ears modeled over the lappets of the tripartite wig (modeled). Wig decorated with *seshed*-headband. Arms crossed over the chest grasping the hoes. Basket on the back. Iconographic details (headband, hoes and basket) are outlined in black
- (b) Overseer. Face crudely shaped with eyes and brows outlined in black. Ears modeled over the lappets of the tripartite wig (modeled). Wig decorated with *seshed*-headband. Arms crossed over the chest grasping the whips. Long kilt carved in high relief. Iconographic details (headband, hoes and basket) are outlined in black.

Inscription

Painted black. One column of hieroglyphs.

“The Osiris Henuttaui, justified”.

Typology

- (a) 4.3.1—Tc: Cl. VIII A2; W 19; H 1; I 5; B 13b; Tp 7b
- (b) 4.3.5—Tc: Cl. IX B; W 19; H 8; I 15; B /; Tp 7b

Other examples of mummiform *shabtis* for Henuttaui are found in museums in Amiens,¹ Basel,² Berlin,³ Brussels,⁴ Cairo,⁵ Clermont-Ferrand,⁶ Copenhagen,⁷ Cortona,⁸ Leiden,⁹ Lisbon,¹⁰ London,¹¹ Madrid,¹² Oslo,¹³ Paris,¹⁴ Roanne,¹⁵ St. Gallen¹⁶ and Wien.¹⁷

Burial Assemblage

The coffin of the “Chantress of Amun” and “Musician of the choir of Mut” Henuttaui, usurped from Nesitanebettaui, is in the Egyptian Museum in Cairo¹⁸ together with her funerary papyrus.¹⁹ The deceased was supplied with two serviettes, an Osiris shroud, mummy braces, a wax embalmer’s plaque, a statuette of Osiris and two *shabti*-boxes.²⁰ Wax figurines of the Sons of Horus were found inside the body.

Bibliography

A. Pellegrini, *Bessarione VII* (1899–1900), p. 27 n. 156.

-
- 1 Dautant et al. 2013, Table 1 n. 29.
 - 2 Schlögl and Brodbeck 1990, 202 n. 125b.
 - 3 Roeder 1913, n. 11967–68.
 - 4 <http://carmentis.kmkg-mrah.be>, E 05426 a and b (overseer).
 - 5 Newberry 1957, 70–71 CG 47066–47080.
 - 6 Dautant et al. 2013, Table 1 n. 29.
 - 7 Mogensen 1918, n. 3987–3988.
 - 8 Botti 1955, 75 n. 91.
 - 9 Schneider 1977, n. 4.3.1. 62–63.
 - 10 Sociedade de Geografia de Lisboa, n. 2507-29 A and B. Araujo 2003, 649–650 n. 53–54.
 - 11 Petrie 1935, UC 307. http://www.britishmuseum.org/research/collection_online, EA 24859–60.
 - 12 MAN 18316.
 - 13 Naguib 1985, EM 8095 and EM 8107.
 - 14 Aubert 1998, n. 31 (Louvre E 22148). The scholar notices examples of overseers with arms crossed over the chest.
 - 15 Gabolde 1990, 129–130 n. 113.
 - 16 Schlögl and Brodbeck 1990, 201 n. 125.
 - 17 Haslauer 1992, AS 6193.
 - 18 Niwiński 1988, 122 n. 100. Outer coffin, inner coffin and mummy-board. Dating: middle 21st Dynasty (mummy braces of H.P. Menkheperre with the name in cartouche).
 - 19 Niwiński 1989, 272 n. 54—S.R.IV.1531 (Book of the Amduat between legs, type A.11.1b).
 - 20 Aston 2009, 174–175 TG. 737.

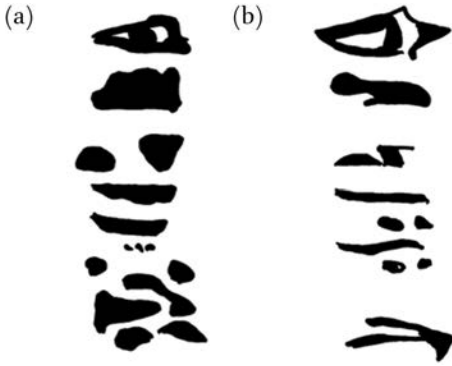

FIGURE 252 Shabtis of Henuttaui (Inscriptions)



FIGURE 253 Shabtis of Henuttaui

31. Shabtis of Hori (*hr*)

Inv. NN. 8572 and 8573

Cairo List: 37

Daressy List: A.143

Height: 12 cm

Raw Material: Blue faience

State of Preservation: Good.

Description

Mummiform servant. Features of the face finely shaped with eyes and brows outlined in black.

Ears modeled over the lappets of the tripartite wig (modeled and striated). The wig is adorned with *seshed*-headband. Arms crossed over the chest grasping the hoes. Basket on the back. Iconographic details (headband, hoes and basket) are outlined in black.

Inscription

Painted black. The hieroglyphs are displayed in five transversal bands. A longitudinal column on the back is left without inscriptions.

- (a) “(1)That may shine the Osiris, Prophet of Amun, Hori, justified. (2)He says: if one reckons the Osiris Hori true of voice (3) to do all the works in the necropolis, (4) ‘I will do that, here I am’ you (5) will say”.
- (b) “(1)That may shine the Osiris, Prophet of Amun, Hori, justified. (2)He says: ‘Oh shabti, if one counts, if one reckons (3) the Osiris Hori to do all the works in the necropolis, (4) to cultivate the fields, to irrigate the lands’, (5) ‘I will do that, here I am’ you will say”.

Typology

4.3.1—Tc: Cl. VIII A1; W 26; H 1; I 5; B 14; Tp 1c

Other examples of *shabtis* for Hori are found in museums in Amsterdam,¹ Basel,² Berlin,³ Brussels,⁴ Cairo,⁵ Clermont-Ferrand,⁶ Copenhagen,⁷ Cortona,⁸ Leiden,⁹ Lisbon,¹⁰ London,¹¹ Madrid,¹² Paris,¹³ Roanne,¹⁴ Stockholm,¹⁵ Toulouse,¹⁶ Uppsala¹⁷ and private collections.¹⁸

Burial Assemblage

Hori was the son of the High priest of Amun Menkheperra and had the titles of “priest of Amun”, “priest of Hathor”, “priest of Seth”, “prophet of Hathor at Gebelein” and “Divine father of Mut and Khonsu”. His coffin set is in the Egyptian Museum in Cairo.¹⁹ The funerary equipment was composed by an Osiris shroud, bandage epigraph and two *shabti*-boxes.²⁰

Bibliography

A. Pellegrini, *Bessarione VII* (1899–1900), p. 27 n. 159

-
- 1 Haarlem 1986, 66–68 Inv. 9465 (four horizontal lines).
 - 2 Schlögl and Brodbeck 1990, 177 n. 109 (five horizontal lines).
 - 3 Roeder 1913, n. 11958 (two examples with four horizontal lines of inscription).
 - 4 <http://carmentis.kmkg-mrah.be>, E 05434 a (four horizontal lines) and b (five horizontal lines).
 - 5 Newberry 1957, pp. 24–27 CG 46570–46589 and pp. 83–84 CG 47171–47174.
 - 6 Dautant et al. 2013, Table 1 n. 37.
 - 7 Mogensen 1918, n. 3951 (four horizontal lines) and 3952 (five horizontal lines).
 - 8 Botti 1955, 75 n. 96 (four horizontal lines).
 - 9 Schneider 1977, n. 4.3.1. 59–60–61 (five horizontal lines).
 - 10 Sociedade de Geografia de Lisboa, n. 2507-37 A and B (five horizontal lines). Araujo 2003, 651–654 n. 55–56.
 - 11 Petrie 1935, UC 253 (overseer). http://www.britishmuseum.org/research/collection_online, EA 24825–26 (five horizontal lines).
 - 12 <http://ceres.mcu.es>, n. 18332–33.
 - 13 Louvre E 20144.
 - 14 Gabolde 1990, 130–131 n. 114 (five horizontal lines).
 - 15 <http://collections.smvk.se/carlotta-mhm>, NME 904 (five horizontal lines).
 - 16 Dautant et al. 2013, Table 1 n. 37 (overseer).
 - 17 Sandman 1931, 101 n. 17 (five horizontal lines).
 - 18 Janes 2002, 117–119 n. 59 (four horizontal lines); Aubert 1998, n. 29 five horizontal lines).
 - 19 Niwiński 1988, 119 n. 83. Outer coffin, inner coffin and mummy-board; gilding. Dating: late 21st Dynasty (mummy-linen of H.P. Pinudjem 11).
 - 20 Aston 2009, 191–192 TG. 816.



FIGURE 254 Shabtis of Hori (Inscriptions)



FIGURE 255 Shabtis of Hori

32. Shabtis of Heritubekhet (*ḥryt-wbḥt*)

Inv. NN. 8564 and 8565

Cairo List: 15

Daressy List: A.133

Height: 10,5 cm

Raw Material: Light blue faience

State of Preservation: Good. The glaze is partially lost.

Description

Mummiform servant.

Face poorly shaped with eyes and brows outlined in black.

Ears modeled over the lappets of the tripartite wig (modeled). The wig is adorned with the *shed*-headband.

Breasts modeled below the lappets. In (a) the breasts are modeled and painted black.

Arms crossed over the chest grasping the hoes.

Basket on the back.

Iconographic details (headband, hoes and basket) are outlined in black.

Inscription

Painted black. One column of hieroglyphs.

“The Osiris Heritubekhet, justified”.

Typology

4.3.1—Tc: Cl. VIII B2; W 19; H 1; I 5; B 12b; Tp 7b

Other examples of *shabtis* for Heritubekhet are found in museums in Amiens,¹ Basel,² Berlin,³ Brussels,⁴ Cairo,⁵ Cleveland,⁶ Copenhagen,⁷ Cortona,⁸ Leiden,⁹

1 Dautant et al. 2013, Table 1 n. 15.

2 Schlögl and Brodbeck 1990, 161 n. 96a.

3 Roeder 1913, n. 11946.

4 <http://carmentis.kmkg-mrah.be>, E 05411 a–b.

5 Newberry 1957, p. 31 CG 46624–46628 and pp. 74–75 CG 47121–47130.

6 Berman and Kenneth 1999, 359 n. 273.

7 Mogensen 1918, n. 3991–3992.

8 Botti 1955, 75 n. 118.

9 Schneider 1977, n. 4.3.1. 66–67.

Lisbon,¹⁰ London,¹¹ Madrid,¹² Marseille,¹³ Oslo,¹⁴ Paris,¹⁵ Roanne,¹⁶ St. Gallen¹⁷ and private collections.¹⁸

Burial Assemblage

Heritubekhet was the granddaughter of the High Priest Menkheperre. She was the daughter of Isetemkheb D, herself daughter of the High Priest Menkheperre, and Pinudjem II. Her coffin set is kept in the Egyptian Museum in Cairo¹⁹ together with her funerary papyri.²⁰ Heritubekhet was buried with a rich funerary equipment: an Osiris shroud, wax eyes covers, a necklace composed of glazed, gold and lapis lazuli amulets, mummy braces, a large blue glaze scarab, a green stone scarab, a bronze hawk pectoral, several linen costumes, red and white serviettes, a bracelet with blue paste beads and amulets, a wax statuette of Hapy in the left hand.²¹

Heritubekhet was also the owner of the *shabti*-box INV. 8529 of the Florence Museum. On this object we can read other titles, such as: “Mistress of the house”, “Chantress of Amun”, “Overseer of the fourth phyle of the musicians of Mut”. Other titles were “Second Prophetess of Mut” and “Supreme chief of the harem of Amun”.

Bibliography

A. Pellegrini, Bessarione VII (1899–1900), p. 15 n. 75–76.

-
- 10 Sociedade de Geografia de Lisboa, n. 2507-15 A and B. Araujo 2003, 564–565 n. 57–58.
 11 Petrie 1935, n. 301. http://www.britishmuseum.org/research/collection_online, EA 24827–28.
 12 MAN 18288–89.
 13 Dautant et al. 2013, Table 1 n. 15.
 14 Naguib 1985, EM 8087 and EM 8090.
 15 Louvre E 22109 and E 22123.
 16 Gabolde 1990, 131–132 n. 115.
 17 Schlögl and Brodbeck 1990, 161 n. 96.
 18 Janes 2002, 119–122 n. 60a and 60b (overseer); Aubert 1998, n. 30.
 19 Niwiński 1988, 131 n. 144. Outer coffin, inner coffin and mummy-board; gilding. Dating: late 21st Dynasty (mummy braces of H.P. Psusennes, mummy-linen of King Siamun).
 20 Niwiński 1989, pp. 284–285 n. 89—S.R.VII.10254 (JE 31986—Book of the Amduat between legs, type A.III.2a) and p. 285 n. 91—S.R.VII.10256 (Book of the Dead probably enclosed in an Osiris figure, type BD.III.1a).
 21 Aston 2009, 188–189 TG. 806.

33. Shabtis of Khaas (*ḥꜣꜣ.s*)

Inv. NN. 8612 and 8613

Cairo List: 21

Daressy List: A.102

Height: (a) 8,5 cm; (b) 8,8 cm

Raw Material: Clay pottery

State of Preservation: Good. Breaks have been repaired in the lower part of the statuettes. The rear is left rough.

Description

- (a) Mummiform servant. Face poorly shaped with eyes, brows and ears modeled. Tripartite wig with modeled lappets. Arms crossed over the chest.
- (b) Overseer. Face poorly shaped with eyes, brows and ears modeled. Tripartite wig with modeled lappets. Right arm raised grasping the whip (modeled). Left arm at the side. Long kilt carved in high relief.

Inscription

Painted black. One column of hieroglyphs.

“The Osiris Khaas, justified”.

Typology

- (a) 4.5.1—Tc: Cl. VIII A1; W ?; H ?; B ?; Tp 7b
- (b) 4.5.5—Tc: Cl. IX C; W ?; H 34; I ? (right: modeled whip); B /; Tp 7b

Other examples of mummiform *shabtis* for Khaas are found in museums in Basel,¹ Berlin,² Brussels,³ Cairo,⁴ Clermont-Ferrand,⁵ Copenhagen,⁶ Cortona,⁷

1 Schlögl and Brodbeck 1990, 200 n. 124a.

2 Roeder 1913, n. 11977.

3 <http://carmentis.kmkg-mrah.be>, E 05417 a–b (overseer).

4 Newberry 1957, 301–302 CG 48225–48233.

5 Dautant et al. 2013, Table 1 n. 21.

6 Mogensen 1918, n. 3950.

7 Botti 1955, 75 n. 88.

Leiden,⁸ Lisbon,⁹ London,¹⁰ Lyon,¹¹ Madrid,¹² Oslo,¹³ Paris,¹⁴ Roanne,¹⁵ St. Gallen¹⁶ and Wien.¹⁷

Burial Assemblage

The “Chantress of Amun” Khaas was buried in a coffin set now in the Egyptian Museum in Cairo.¹⁸ Her funerary equipment was composed of a green heart scarab, a wax embalmer’s plaque, a necklace and two *shabti*-boxes.¹⁹

Bibliography

A. Pellegrini, Bessarione VII (1899–1900), p. 29 n. 169.

-
- 8 Schneider 1977, n. 4.5.1. 24 and n. 4.5.5.1.
- 9 Sociedade de Geografia de Lisboa, n. 2507-21 A and B. Araujo 2003, 659–660 n. 61–62. Museu Nacional de Arqueologia, E 81. Araujo 2003, 734 n. 34.
- 10 Petrie 1935, n. 454. http://www.britishmuseum.org/research/collection_online, EA 24805–06.
- 11 Dautant et al. 2013, Table 1 n. 21.
- 12 MAN 18300–01.
- 13 Naguib 1985, EM 8116–8117.
- 14 Aubert 1998, n. 32.
- 15 Gabolde 1990, 132–133 n. 116.
- 16 Schlögl and Brodbeck 1990, 200 n. 124.
- 17 Haslauer 1992, AS 6165–6166.
- 18 Niwiński 1988, 124 n. 108. Outer coffin, inner coffin and mummy-board. Dating: middle/late 21st Dynasty.
- 19 Aston 2009, 181 TG. 775.

34. Shabtis of Khonsuemheb (*ḥnsw-m-ḥb*)

Inv. NN. 8582 and 8583

Cairo List: 42

Daressy List: A.106

Height: (a) 9,3 cm; (b) 9,4 cm

Raw Material: Red pottery painted green.

State of Preservation: Good. The painting has disappeared almost completely.

In (a) the inscription is totally faded. The material overflowed from the mould was not removed.

Description

Mummiform servant.

Features of the face finely modeled with eyes, brows and cheeks outlined black. Ears modeled over the lappets of the tripartite wig (modeled). Wig adorned with a *seshed*-headband.

Arms crossed over the chest grasping the hoes.

Basket on the back.

Iconographic details (headband, hoes and basket) are outlined in black.

Inscription

Painted black. One column of hieroglyphs.

“The Osiris Khonsuemheb”.

Typology

(a) 4.5.1—Tc: Cl. VIII A2; W 19; H 1; I 5; B 13a; Tp 7b

(b) 4.5.1—Tc: Cl. VIII A2; W 19; H 1; I 5; B 8; Tp 7b

Other examples of *shabtis* for Khonsuemheb are found in museums in Basel,¹ Berlin,² Brussels,³ Cairo,⁴ Clermont-Ferrand,⁵ Copenhagen,⁶ Leiden,⁷ Lisbon,⁸ London,⁹ Oslo,¹⁰ Paris,¹¹ Roanne,¹² St. Gallen,¹³ Voronezh¹⁴ and Wien.¹⁵

Burial Assemblage

Khonsuemheb was “wab-priest at the prow of Mut”, “Scribe of the counting of the grain in the Estate of Amun”, “Divine father of Amun”, “Prophet and divine father of Khonsu-Re”. He was buried in a coffin now in the Egyptian Museum in Cairo¹⁶ together with his funerary papyrus.¹⁷ The funerary equipment comprised false braces, an Osiris shroud, a wax heart amulet, a wax object as embalmer’s plaque, wax figurines of the Sons of Horus inside the body and two *shabti*-boxes.¹⁸

Bibliography

A. Pellegrini, *Bessarione VII* (1899–1900), p. 29 n. 175.

-
- 1 Schlögl and Brodbeck 1990, 188 n. 115.
 - 2 Roeder 1913, n. 11962 (two examples).
 - 3 <http://carmentis.kmkg-mrah.be>, E 05439 a–b.
 - 4 Newberry 1957, 294 CG 48120–48129.
 - 5 Dautant et al. 2013, Table 1 n. 42.
 - 6 Mogensen 1918, n. 3929–3930.
 - 7 Schneider 1977, n. 4.5.1. 25–26.
 - 8 Sociedade de Geografia de Lisboa, n. 2507-42 A and B. Araujo 2003, 661–662 n. 63–64.
 - 9 http://www.britishmuseum.org/research/collection_online, EA 24817–18.
 - 10 Naguib 1985, EM 8104(a) and EM 8109.
 - 11 Aubert 1998, n. 34 (Louvre E 20237).
 - 12 Gabolde 1990, 133 n. 117.
 - 13 Schlögl and Brodbeck 1990, 189 n. 115a.
 - 14 Berlev and Hodjash 1998, n. 79.
 - 15 Haslauer 1992, AS 6173–6174.
 - 16 Niwiński 1988, 132 n. 150. Inner coffin and mummy-board. Dating: middle 21st Dynasty.
 - 17 Niwiński 1989, p. 256 n. 7—S.R.IV. 541 (JE 95644—Book of the Amduat between legs, type A.III.2a) and p. 276 n. 65—S.R.VII.10228 (Book of the Dead probably enclosed in an Osiris shroud, type BD.III.1b).
 - 18 Aston 2009, 182 TG. 779.

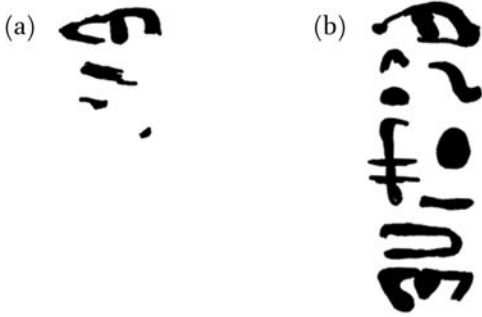

FIGURE 260 Shabtis of Khonsuemheb (Inscriptions)



FIGURE 261 Shabtis of Khonsuemheb

35. Shabtis of Khonsumes (*hnsw-ms*)

Inv. NN. 8580 and 8581

Cairo List: 24

Daressy List: A.82 or A.121

Height: (a) 9,3 cm; (b) 8,7 cm

Raw Material: Pottery painted green and varnished.

State of Preservation: Good. The painting has almost completely disappeared and the inscriptions are faint. In (a) a break has been repaired in the lower part.

Description

Mummiform servant.

Face poorly shaped with eyes, brows and lips outlined in black.

Ears modeled over the lappets of the tripartite wig (modeled).

Breasts modeled below the lappets.

Arms crossed over the chest grasping the hoes.

Basket on the back.

Iconographic details (hoes and basket) are outlined in black.

Inscription

Painted black. One column of hieroglyphs.

“That may shine the Osiris Khonsumes”.

Typology

4.5.1—Tc: Cl. VIII B1; W 16; H 1; I 5; B 17; Tp 7b

Other examples of *shabtis* for Khonsumes are found in museums in Basel,¹ Berlin,² Brussels,³ Copenhagen,⁴ Cortona,⁵ Leiden,⁶ Lisbon,⁷ London,⁸ Madrid,⁹ Paris,¹⁰ Roanne,¹¹ St. Gallen,¹² Stockholm¹³ and Wien.¹⁴

Burial Assemblage

A coffin set prepared for the “Scribe of the Estate of Amun” Khonsumes is preserved in Florence Museum (N.Inv. 8527, A.22). Daressy ascribes the *shabtis* here described to this deceased,¹⁵ but the coffin set A.22 was usurped by an anonymous woman and for this reason this object can hardly be related with the *shabtis*.

Two other Khonsumes were buried in Bab el-Gasus: the deceased from A.82¹⁶ and the owner of A.121.¹⁷ Each of these two men holds the title of “Scribe of the Estate of Amun”. It is impossible to determine the *shabtis* that belonged to each one. The same can be said for a *shabti*-box with the name of Khonsumes once kept in Berlin and now lost.¹⁸

Bibliography

A. Pellegrini, Bessarione VII (1899–1900), p. 30 n. 176.

-
- 1 Schlögl and Brodbeck 1990, 214 n. 136.
 - 2 Roeder 1913, n. 11966 (two examples).
 - 3 <http://carmentis.kmkg-mrah.be, E 05420 a–b>.
 - 4 Mogensen 1918, n. 3933–3934.
 - 5 Botti 1955, 76 n. 126.
 - 6 Schneider 1977, n. 4.5.1. 27–28.
 - 7 Sociedade de Geografia de Lisboa, n. 2507-24 A and B. Araujo 2003, 663–664 n. 65–66.
 - 8 http://www.britishmuseum.org/research/collection_online, EA 24841–42.
 - 9 MAN 18306–07.
 - 10 Dautant et al. 2013, Table 1 n. 24 (Louvre E10637bis).
 - 11 Gabolde 1990, 134 n. 118.
 - 12 Schlögl and Brodbeck 1990, 189 n. 115b.
 - 13 <http://collections.smvk.se/carlotta-mhm, NME 909>.
 - 14 Haslauer 1992, AS 6163.
 - 15 Daressy 1907, 16.
 - 16 Niwiński 1988, 104 n. 2. Inner coffin and mummy-board. Dating: middle 21st Dynasty.
 - 17 Niwiński 1988, 174 n. 398. Outer coffin, inner coffin and mummy-board. Dating: middle 21st Dynasty.
 - 18 Aston 2009, 167 TG. 695.

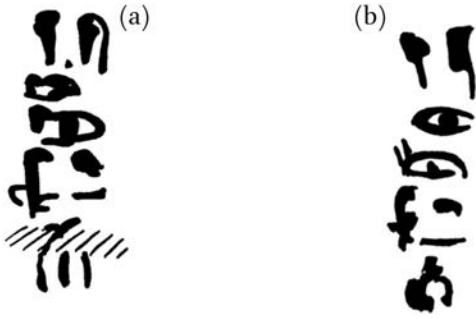

FIGURE 262 Shabtis of Khonsumes (Inscriptions)



FIGURE 263 Shabtis of Khonsumes

36. Shabtis of Shedsuamun (*Śd-sw-Īmn*)

Inv. NN. 8618 and 8619

Cairo List: 23

Daressy List: A.30

Height: 9 cm

Raw Material: Light blue faience

State of Preservation: Good. In (b) the glaze is eroded in the lower part. The painted decoration is lost.¹

Description

Mummiform servant.

Face slightly modeled.

Ears modeled over the lappets of the tripartite wig (modeled).

Arms crossed over the chest.

Inscription

Objects from the same *shabti*-box reveal that these *shabtis* displayed an inscription written in one column of hieroglyphs outlined in black, saying: “That may shine the Osiris Shedsuamun, justified”.

Typology

4.3.1—Tc: Cl. VIII A1; W 19 (?); H 8; I 5 (?); B ?; Tp 7b (?)

¹ The hieroglyphic inscription faded away, but the matching of the ushebtis with the deceased Shedsuamun is confirmed by comparisons with the other samples in the other collections (see below).

Other examples of *shabtis* for Shedsuamun are found in museums in Boulogne-sur-mer,² Cairo,³ Copenhagen,⁴ Cortona,⁵ Leiden,⁶ Lisbon,⁷ Madrid,⁸ Paris,⁹ Roanne,¹⁰ St. Gallen,¹¹ Stockholm,¹² Uppsala¹³ and private collections.

Burial Assemblage

The “*wab*-priest” and “scribe of the treasury of Amun” Shedsuamun was buried in a coffin set now in Cairo.¹⁴

The funerary equipment included an Osiris shroud and a funerary papyrus now in Cairo Museum.¹⁵

Bibliography

A. Pellegrini, *Bessarione VII* (1899–1900), p. 16 n. 83.



FIGURE 264 Shabtis of Shedsuamun

- 2 Dautant et al. 2013, Table 1 n. 23.
- 3 Newberry 1957, 28–29 CG 46590–96 and CG 46601–03.
- 4 Mogensen 1918, 59 n. 3963–3964.
- 5 Botti 1955, 76 n. 95.
- 6 Schneider 1977, n. 4.3.1 69–70.
- 7 Sociedade de Geografia de Lisboa, n. 2507-24 A and B. Araujo 2003, 665–666 n. 67–68.
- 8 MAN 18305.
- 9 Louvre E 22119. Aubert 1998, 87 n. 35.
- 10 Gabolde 1990, 146 n. 131.
- 11 Schlögl and Brodbeck 1990, 165 n. 100.
- 12 <http://collections.smvk.se/carlotta-mhm>, NME 907.
- 13 Sandman 1931, 103 n. 24.
- 14 Niwiński 1988, 126 n. 116. Outer coffin, inner coffin and mummy-board. Dating: middle XXI Dynasty (mummy braces of H.P. Pinudjem).
- 15 Aston 2009, 168 TG. 703.

37. Shabti of Gautseshenu (*Gꜣwt-sšnw*)¹

Inv. N. 8615

Cairo List: 41

Daressy List: A.152

Height: 9,5 cm

Raw Material: Blue faience

State of Preservation: Good.

Description

Mummiform servant.

Features of the face finely modeled with eyes, brows and lips outlined in black.

Ears modeled over the lappets of the tripartite wig (modeled and striated).

Breasts modeled below the lappets.

Arms crossed over the chest grasping the hoes.

Big basket on the back.

Iconographic details (striated wig, hoes and basket) are outlined in black.

Inscription

Painted black. One column of hieroglyphs.

“That may shine the Osiris Gautseshenu, justified”.

Typology

4.3.1—Tc: Cl. VIII B2; W 21; H 8; I 5; B 14; Tp 7b

¹ INV. 8614 is LOST, but the Catalogue of G. Botti its features are described as a statuette in blue faience, 9,7 cm high and with faded inscription. It could be the double of INV. 8615.

Other examples of *shabtis* for Gautseshen are found in museums in Basel,² Berlin,³ Boulogne-sur-Mer,⁴ Brussels,⁵ Cairo,⁶ Leiden,⁷ Lisbon,⁸ London,⁹ Oslo,¹⁰ Paris,¹¹ Roanne¹² and private collections.¹³

Burial Assemblage

Two ladies named Gautseshenu were buried in Bab el-Gasus. Gautseshenu A (A.152), daughter of Menkheperra and Isitemkhebi C, was the wife of Tjanefer (A.151); Gautseshenu B (A.139) was the daughter of Gautseshenu A.

Gautseshenu A had *shabtis* in blue faience, while the second had lesser elegant statuettes crafted in light blue faience.

Gautseshenu A was “Great chief of the harem of Amun in the third phyle” and “Great chief of the harem of Mut”. Her coffin set is in the Egyptian Museum in Cairo¹⁴ together with her funerary papyri.¹⁵ The burial equipment included mummy braces, a scarab, a stela and two *shabti*-boxes.¹⁶

Bibliography

A. Pellegrini, Bessarione VII (1899–1900), p. 28 n. 168.

-
- 2 Schlögl and Brodbeck 1990, 159 n. 94.
 - 3 Roeder 1913, n. 11899 and 11974 (two examples).
 - 4 Dautant et al. 2013, Table 1 n. 41.
 - 5 <http://carmentis.kmkg-mrah.be>, E 05438 a–b.
 - 6 Newberry 1957, pp. 45–46 CG 46789–46803 and p. 71 CG 47081–47085.
 - 7 Schneider 1977, n. 4.3.1. 71.
 - 8 Sociedade de Geografia de Lisboa, n. 2507-41 A and B. Araujo 2003, 667–668 n. 69–70. Museu Nacional de Arqueologia, E 82. Araujo 2003, 735 n. 35.
 - 9 http://www.britishmuseum.org/research/collection_online, EA 24851–52.
 - 10 Naguib 1985, EM 8089 and EM 8104(b).
 - 11 Louvre E 22121.
 - 12 Gabolde 1990, 135 n. 119.
 - 13 Aubert 1998, n. 37.
 - 14 Niwiński 1988, 121 n. 92. Outer coffin, inner coffin and mummy-board. Type of the outer lid 11a, type of the inner lid and mummy-board 11c. Gilding. Dating: middle XXI Dynasty (mummy braces of King Amenemope).
 - 15 Niwiński 1989, p. 264 n. 32—S.R.IV. 936 (JE 95838 Book of the Dead probably enclosed in an Osiris figure, type BD.11.2) and p. 286 n. 94—S.R.VII.10265 (Book of the Amduat around the legs, type A.11.1a).
 - 16 Aston 2009, 194 TG. 825.

FIGURE 265
Shabti of Gautseshenu (Inscription)



FIGURE 266 Shabti of Gautseshenu

38. Shabtis of Tabakenkhonsu (*tꜣ-bꜣk-n-ḥnsw*)

Inv. NN. 8604 and 8605

Cairo List: 28

Daressy List: A.10

Height: (a) 11,6 cm; (b) 9,7 cm

Raw Material: Red pottery painted white.

State of Preservation: Good. The white paint is nearly lost on the back. In (a) the inscription is faded in the final part.

Description

Mummiform servant.

Face crudely shaped with eyes and brows outlined in black.

Ears modeled over the lappets of the tripartite wig (modeled). Wig decorated with *seshed*-headband.

In (a) the breasts are slightly modeled below the lappets.

Arms crossed over the chest grasping the hoes.

Basket on the back.

Iconographic details (headband, hoes and basket) are outlined in black.

Inscription

Painted black. One column of hieroglyphs.

“The Osiris Tabakenkhonsu, justified”.

Typology

(a) 4.5.1—Tc: Cl. VIII B1; W 19; H 8; I 5; B 13b; Tp 7b

(b) 4.5.1—Tc: Cl. VIII A1; W 19; H 8 (?); I 5; B 13b; Tp 7b

These are two examples of the pottery type. Other examples of this type of *shabtis* are found in museums in Amiens,¹ Basel,² Berlin,³ Brussels,⁴ Cleveland,⁵

1 Dautant et al. 2013, Table 1 n. 28.

2 Schlögl and Brodbeck 1990, 193 n. 118a.

3 Roeder 1913, n. 11963–64.

4 <http://carmentis.kmkg-mrah.be>, E 05425 a–b.

5 Berman and Kenneth 1999, 361 n. 275.

Copenhagen,⁶ Cortona,⁷ Leiden,⁸ Lisbon,⁹ London,¹⁰ Madrid,¹¹ Oslo,¹² Paris,¹³ Roanne,¹⁴ St. Gallen¹⁵ and Wien.¹⁶

Burial Assemblage

The coffin set of the “Chantress of Amun” and “Musician of the choir of Mut” Tabakenkhonsu is in the Kunsthistorisches Museum in Vienna,¹⁷ while her funerary papyrus is in the Egyptian Museum in Cairo.¹⁸ The burial equipment included an Osiris shroud and two *shabti*-boxes.¹⁹

Bibliography

A. Pellegrini, *Bessarione VII* (1899–1900), p. 33 n. 199–200.

6 Mogensen 1918, n. 3925–3926.

7 Botti 1955, 76 n. 113.

8 Schneider 1977, n. 4.5.1. 29–30.

9 Sociedade de Geografia de Lisboa, n. 2507-28 A. Araujo 2003, 669 n. 71.

10 Petrie 1935, n. 450. http://www.britishmuseum.org/research/collection_online, EA 24881–82.

11 MAN 18314–15.

12 Naguib 1985, EM 8080 and 8081 (overseer).

13 Aubert 1998, n. 40 (Louvre E 22055).

14 Gabolde 1990, 136 n. 120.

15 Schlögl and Brodbeck 1990, 193 n. 118.

16 Haslauer 1992, AS 6175.

17 Niwiński 1988, 177 n. 414. Outer coffin, inner coffin and mummy-board. Type of the outer lid 111b, type of the inner lid and mummy-board 111a. Dating: middle/late XXI Dynasty.

18 Niwiński 1989, 274 n. 59—S.R.VII.10222 (Book of the Dead probably enclosed in an Osiris figure, type BD.11.1).

19 Aston 2009, 165 TG. 683.

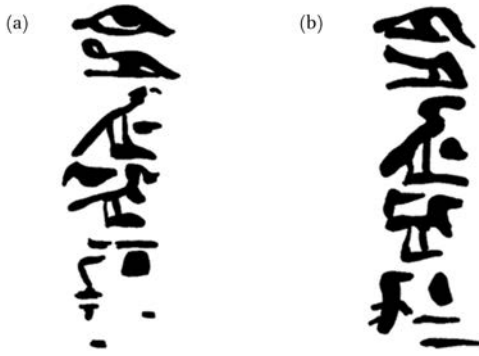

FIGURE 267 Shabtis of Tabakenkhonsu (Inscriptions)



FIGURE 268 Shabtis of Tabakenkhonsu

39. Shabtis of Tashedkhonsu (*tꜣ-šd-ḥnsw*)

Inv. NN. 8557 and 8578

Cairo List: 11

Daressy List: A.137

Height: (a) 9,8 cm; (b) 12 cm

Raw Material: Blue faience

State of Preservation: Good.

Description

Mummiform servant.

Face poorly shaped with eyes and brows outlined in black.

Ears modeled over the lappets of the tripartite wig (modeled). Wig adorned with *seshed*-headband.

Arms crossed over the chest grasping the hoes.

Basket on the back.

Iconographic details (headband, hoes and basket) are outlined in black.

Inscription

Painted black. One column of hieroglyphs.

(a) “That may shine the Osiris Tashedkhonsu, justified”.

(b) “That may shine the Osiris Tjentshedkhonsu, justified”.

Typology

(a) 4.3.1—Tc: Cl. VIII A1; W 19; H 8; I 5 (?); B 12b; Tp 7b

(b) 4.3.1—Tc: Cl. VIII A1; W 19; H 8; I 5; B ?; Tp 7b

Other examples of the taller *shabtis* for Tashedkhonsu are found in Boulogne-sur-mer,¹ Brussels,² Copenhagen,³ Leiden,⁴ Lisbon,⁵ Paris,⁶ Roanne,⁷ St. Gallen,⁸ Toulouse⁹ and private collections.¹⁰

Examples of *shabtis* for Tashedkhonsu, with the same differences in the writing of the name, are found in Cairo,¹¹ London,¹² St. Gallen,¹³ Stockholm,¹⁴ Uppsala¹⁵ and Warsaw.¹⁶

Burial Assemblage

Two women named Tashedkhonsu were buried in Bab el-Gasus.

The deceased from A.137 was buried in a coffin now kept in the Egyptian Museum in Cairo¹⁷ together with one of her funerary papyri.¹⁸ The other one is kept in Florence.¹⁹ Two *shabti*-boxes were part of the funerary equipment.²⁰ The deceased hold several titles including “Mistress of the house”, “Chantress of Amun”, “Prophetess of Amun in Karnak”, “Prophetess of Mut of the Mammisi” and “Prophetess of Nekhbeth of Hierakonpolis”.

The coffin set of the deceased A.138 remains unidentified, but according to Lieblein²¹ the woman had the titles “Chantress of Amun” and “Musician of the choir of Mut”.²²

-
- 1 Dautant et al. 2013, Table 1 n. 11.
 - 2 <http://carmentis.kmkg-mrah.be, E 05407 a–b>.
 - 3 Mogensen 1918, n. 4001.
 - 4 Schneider 1977, n. 4.3.1.74 and 76.
 - 5 Sociedade de Geografia de Lisboa, n. 2507-11 A and B. Araujo 2003, 670–671 n. 72–73.
 - 6 Louvre E 22087.
 - 7 Gabolde 1990, 138 n. 123 (tall size, black wig).
 - 8 Schlögl and Brodbeck 1990, 191 n. 116b.
 - 9 Dautant et al. 2013, Table 1 n. 11.
 - 10 Aubert 1998, n. 45.
 - 11 Newberry 1957, pp. 31–32 CG 46629–46633, p. 36 CG 46699–46713 and p. 291 CG 48091–48092.
 - 12 http://www.britishmuseum.org/research/collection_online, EA 24809 and 24839–40.
 - 13 Schlögl and Brodbeck 1990, 190–191 n. 116 and 116c.
 - 14 <http://collections.smvk.se/carlotta-mhm, NME 846 B and 898>.
 - 15 Sandman 1931, 103 n. 22 and p. 104 n. 25.
 - 16 Pomorska 1959, 122–123 n. 35.
 - 17 Niwiński 1988, 120 n. 88. Inner coffin and mummy-board. Type of the lid IIIa, type of the mummy-board 11d. Dating: middle XXI Dynasty.
 - 18 Niwiński 1989, 280 n. 77—S.R. VII.10240 (Book of the Dead probably enclosed in an Osiris figure, type BD.III.1b).
 - 19 Niwiński 1989, 308 FLORENCE n. 3663 (Book of the Amduat between legs, type A.III.1b).
 - 20 Aston 2009, 189–190 TG. 810.
 - 21 Lieblein 1982, 1002.
 - 22 Niwiński 1988, 181 n. 434.

Two different types of statuettes named for Tashedkhonsu come from Bab el-Gasus and show remarkable differences in the writing of the name. At a first sight L. Aubert ascribes the taller *shabtis* with modeled wig and headband painted black to the deceased A 138; for the deceased A 137 she deserves the smaller statuettes with black wig. Indeed the scholar admits that this classification is unsatisfactory, because the same series can show different writing of the name.

The *shabtis* here described are two examples of the taller series, showing the writing of the name Tashedkhonsu (INV.8578) and Tjentshedkhonsu (INV. 8557). See N.Cat. 40 for the second series.

Bibliography

A. Pellegrini, Bessarione VII (1899–1900), n. 193, 207, 213.

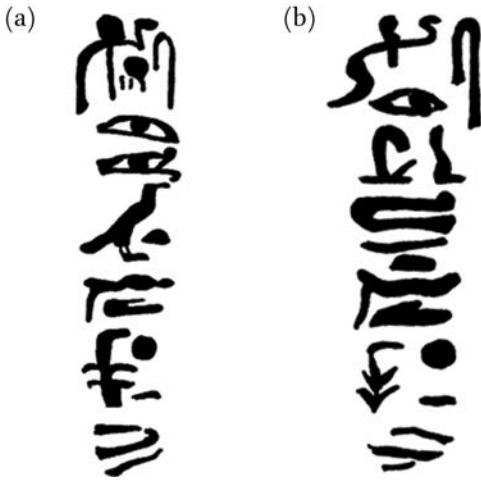

FIGURE 269 Shabtis of Tashedkhonsu (Inscriptions)



FIGURE 270 Shabtis of Tashedkhonsu

40. Shabtis of Tashedkhonsu (*tꜣ-šd-ḥnsw*)

Inv. NN. 8555 and 8621

Cairo List: 36

Daressy List: A.137

Height: (a) 11,7 cm; (b) 10,5 cm

Raw Material: Blue faience

State of Preservation: Good. In (a) the inscription is quite faded. The statuette (b) was broken and repaired in the lower part.

Description

Mummiform servant.

Features of the face finely modeled with eyes and brows outlined in black.

Ears modeled over the lappets of the tripartite wig (modeled and painted black).

Breasts modeled below the lappets. In (a) the breasts are modeled and painted black.

Arms crossed over the chest grasping the hoes (modeled). In (a) the implements (hoes) are simply modeled.

Basket on the back.

Iconographic details (hoes and basket) are outlined in black.

Inscription

Painted black. One column of hieroglyphs.

(a) “That may shine the Osiris Tjentshedkhonsu, [justified?]”.

(b) “That may shine the Osiris Shedytakhonsu, justified”.

Typology

(a) 4.3.1—Tc: Cl. VIII B1; W 17; H 1; I 5 (?); B 16; Tp 7b

(b) 4.3.1—Tc: Cl. VIII B1; W 17; H 1; I 14; B 12b; Tp 7b

Examples of the smaller series are found in Berlin,¹ Brussels,² Copenhagen,³ Leiden,⁴ Lisbon,⁵ Madrid,⁶ Paris,⁷ Roanne,⁸ St. Gallen,⁹ Toulouse¹⁰ and private collections.¹¹

Examples of statuettes with inverted symbols in the name are found in London,¹² Paris¹³ and Oslo.¹⁴

Bibliography

A. Pellegrini, *Bessarione VII* (1899–1900), n. 193, 207, 213.

-
- 1 Roeder 1913, n. 11960.
 - 2 <http://carmentis.kmkg-mrah.be>, E 05433 a–b and E 05451.
 - 3 Mogensen 1918, n. 4002 and n. 1574.
 - 4 Schneider 1977, n. 4.3.1. 75.
 - 5 Sociedade de Geografia de Lisboa, n. 2507-36 A and B. Araujo 2003, 672–673 n. 74–75.
 - 6 MAN 18280–81.
 - 7 Aubert 1998, n. 45 (Louvre E 22094).
 - 8 Gabolde 1990, 139 n. 124 (small size, black wig).
 - 9 Schlögl and Brodbeck 1990, 190 n. 116a.
 - 10 Dautant et al. 2013, Table 1 n. 36.
 - 11 Janes 2002, 131–132 n. 67.
 - 12 http://www.britishmuseum.org/research/collection_online, EA 24810.
 - 13 Louvre E 22101.
 - 14 Naguib 1985, 71–72 EM 8102 (small size, black wig).

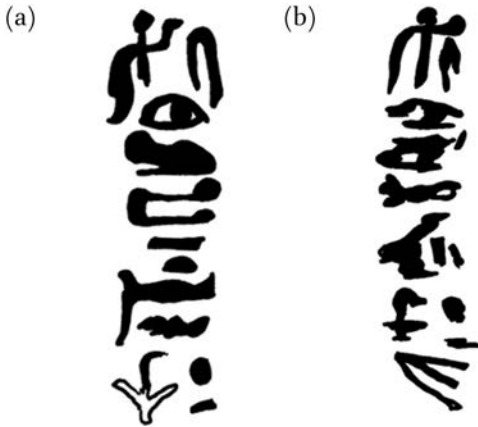

FIGURE 271 Shabtis of Tashedkhonsu (Inscriptions)



FIGURE 272 Shabtis of Tashedkhonsu

41. Shabtis of Taditmut (*t3-di.t-Mwt*)

Inv. NN. 8574 and 8575

Cairo List: 6

Daressy List: A.91

Height: 12 cm

Raw Material: Light blue faience

State of Preservation: Good. In (b) the face is damaged and the inscription is faint.

Description

- (a) Mummiform servant. Face crudely shaped with eyes and brows outlined in black. Ears modeled over the lappets of the tripartite wig (modeled). Wig adorned with *seshed*-headband. Arms crossed over the chest grasping the hoes (modeled). Basket on the back. Iconographic details (headband, hoes and basket) are outlined in black.
- (b) Overseer. Face crudely shaped with eyes and brows outlined in black. Lappets of the tripartite wig modeled. The wig is adorned with *seshed*-headband with long streamers depicted at the back. Left arm crossed over the chest grasping the hoe (modeled) and the right arm extended along the body. Long kilt carved in high relief. Iconographic details (headband and whip) are outlined in black.

Inscription

Painted black. One column of hieroglyphs bounded by two vertical black lines. “The Osiris, Mistress of the house, Chantress of Amun, Taditmut”.

Typology

- (a) 4.3.1—Tc: Cl. VIII A1; W 19; H 8; I 5; B 17; Tp 7c
- (b) 4.3.5—Tc: Cl. IX C; W 20; H 34; I ? (right: narrow modeled hoe and black painted cord—left: ?); B /; Tp 7a

Other examples of *shabtis* for Taditmut are found in museums in Basel,¹ Berlin,² Boulogne-sur-Mer,³ Brussels,⁴ Cairo,⁵ Cortona,⁶ Leiden,⁷ Lisbon,⁸ London,⁹ Oslo,¹⁰ Paris,¹¹ Roanne,¹² St. Gallen,¹³ Wien¹⁴ and private collections.¹⁵

Burial Assemblage

The coffin set of the “Chantress of Amun” and “Mistress of the house” Taditmut (usurped from Akhmut) is in the Egyptian Museum in Berlin,¹⁶ while her funerary papyrus is in the Egyptian Museum in Cairo.¹⁷ The burial equipment included mummy braces, a green basalt heart scarab, a bronze hawk pectoral, a necklace with gold and glazed amulets, wax figurines of the Sons of Horus inside the body, a funerary stela and two *shabti*-boxes.¹⁸ A small magical papyrus was found on the neck.¹⁹

Bibliography

A. Pellegrini, *Bessarione VII* (1899–1900), p. 36 n. 208.

-
- 1 Schlögl and Brodbeck 1990, 172 n. 105a.
 - 2 Roeder 1913, n. 11896–97.
 - 3 Dautant et al. 2013, Table 1 n. 6.
 - 4 <http://carmentis.kmkg-mrah.be>, E 05404 and E 05449.
 - 5 Newberry 1957, p. 35 CG 46692–46696 and pp. 71–73 CG 47086–47110.
 - 6 Botti 1955, 76 n. 120.
 - 7 Schneider 1977, n. 4.3.1. 77–78.
 - 8 Sociedade de Geografia de Lisboa, n. 2507-6 A and B. Araujo 2003, 374–375 n. 76–77.
 - 9 http://www.britishmuseum.org/research/collection_online, EA 24823.
 - 10 Naguib 1985, EM 8101 and EM 8106(a).
 - 11 Louvre E 22099.
 - 12 Gabolde 1990, 140–142 n. 125–126.
 - 13 Schlögl and Brodbeck 1990, 172 n. 105.
 - 14 Haslauer 1992, AS 6238.
 - 15 Janes 2002, 132–133 n. 68; Aubert 1998, n. 42.
 - 16 Niwiński 1988, 109–110 n. 34. Outer coffin, inner coffin and mummy-board, type of the lids 111a. Dating: middle/late XXI Dynasty.
 - 17 Niwiński 1989, 278 n. 71—S.R.VII.10234 (JE 35404—Book of the Amduat between legs, type A.III.1b).
 - 18 Aston 2009, 179 TG. 764.
 - 19 Niwiński 1989, 300 n. CAIRO B—S.R.IV.997 (JE 35413 Magical papyrus, type U).

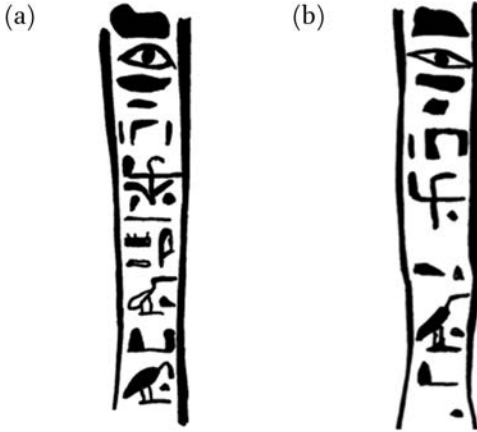

FIGURE 273 Shabtis of Taditmut (Inscriptions)



FIGURE 274 Shabtis of Taditmut

42. Shabtis of Tjanefer (*tꜣ-nfr*)

Inv. NN. 8622 and 8623

Cairo List: 40

Daressy List: A.151

Height: (a) 11 cm; (b) 9 cm

Raw Material: Blue faience

State of Preservation: Good.

Description

Mummiform servant.

Features of the face finely shaped with eyes and brows outlined in black.

Ears modeled over the lappets of the tripartite wig (modeled and striated). The wig is adorned with *seshed*-headband. In (a) the headband is decorated with a geometrical pattern.

Arms crossed over the chest grasping the hoes.

Basket on the back.

Iconographic details (headband, hoes and basket) are outlined in black.

Inscription

Painted black. One column of hieroglyphs.

(a) “That may shine the Osiris, fourth prophet of Amun, Tjanefer”.

(b) “That may shine the Osiris, third prophet of Amun, Tjanefer”.

Typology

4.3.1—Tc: Cl. VIII A1; W 25 (or 26); H 1; I 1; B 14; Tp 7b

Other examples of *shabtis* for Tjanefer are found in museums in Amsterdam,¹ Basel,² Berlin,³ Brussels,⁴ Copenhagen,⁵ Leiden,⁶ Lisbon,⁷ London,⁸ Lyon,⁹ Madrid,¹⁰ Oslo,¹¹ Roanne,¹² St. Gallen¹³ and private collections.¹⁴

Burial Assemblage

The burial equipment of Tjanefer (A.151) was found in the most important chamber of the Bab el-Gasus tomb. The man was probably the son of the High Priest Menkheperre and brother of the High Priest Pinudjem II. Beside the coffin of Tjanefer, the coffin of his wife Gautseshenu (N. Cat. 37) was found. It is conceivable that it was Tjanefer for whom the Tomb of the Priests had originally been made, before a cachette was organized there in the late 21st Dynasty.¹⁵

Tjanefer had several titles including “Prophet of Montu, lord of Thebes”, “Prophet of Khnum, lord of the Cataract”, “Divine father beloved of the god”, “Chief of the secrets in the sky, on the earth and in the Duat”, “The one who opens the doors of the sky in Karnak”, “*Setem-priest* in the horizon of the eternity”, “Chief of the herds of the house in the Estate of Amun”, “Overseer of the Estates of Re”. He was also “Third Prophet of Amun”, although on some *shabtis* still appears the title of “Fourth Prophet” (a). The coffin of Tjanefer is in the Egyptian Museum in Cairo¹⁶ together with his funerary papyri.¹⁷ The deceased was buried with floral garlands over ears, eyes, nose and mouth. The funer-

1 Haarlem 1990, 106–107 Inv. 8807.

2 Schlögl and Brodbeck 1990, 160 n. 95a.

3 Roeder 1913, n. 11972 (two examples).

4 <http://carmentis.kmkg-mrah.be>, E 05437 a–b.

5 Mogensen 1918, n. 3971.

6 Schneider 1977, n. 4.3.1. 79–80.

7 Sociedade de Geografia de Lisboa, n. 2507–40 A and B. Araujo 2003, 676–677 n. 78–79.

8 Petrie 1935, UC 303. http://www.britishmuseum.org/research/collection_online, EA 24831–32.

9 Dautant et al. 2013, Table 1 n. 40 (overseer).

10 <http://ceres.mcu.es>, n. 18339 (overseer).

11 Naguib 1985, EM 8119.

12 Gabolde 1990, 142 n. 127.

13 Schlögl and Brodbeck 1990, 160 n. 95.

14 Janes 2002, 134–135 n. 69; Aubert 1998, n. 47.

15 Niwiński 2007, 177.

16 Niwiński 1988, 131 n. 142. Outer coffin, inner coffin and mummy-board. Type of the lids IIIa, gilding. Dating: middle XXI Dynasty (mummy braces of H.P. Pinudjem II).

17 Niwiński 1989, p. 264 n. 33—S.R.IV. 952 (JE 95646—Book of the Amduat between legs, type A.1.1) and pp. 281–282 n. 81—S.R.VII.10244 (JE 33997 Book of the Dead probably enclosed in an Osiris shroud, type BD.III.1a).

43. Shabtis of Tent-tauī (*tnt-tꜣ.wy*)

Inv. NN. 8602 and 8603

Cairo List: 16

Daressy List: A ?

Height: (a) 9,8 cm; (b) 9,7 cm

Raw Material: Pottery painted light green.

State of Preservation: Good.

Description

(a) Mummiform servant.

Face roughly crafted with eyes and brows outlined black.

Ears modeled over the lappets of the tripartite wig (modeled). Wig adorned with *seshed*-headband.

Arms crossed over the chest grasping the handles of the basket.

Basket on the back.

Iconographic details (headband, hoes and basket) are outlined in black.

(b) Overseer.

Face roughly crafted with eyes, brows and lips outlined in black.

Ears modeled over the lappets of the tripartite wig (modeled). Wig adorned with *seshed*-headband.

Left arm crossed over the chest grasping the hoe (painted black) and the right arm extended along the body.

Long kilt carved in high relief.

Iconographic details (headband, hoes and basket) are outlined in black.

Inscription

Painted black. One column of hieroglyphs.

“The Osiris Tent-tauī, justified”.

Typology

(a) 4-5-1—Tc: Cl. VIII A1; W 19; H 8; I ?; B 13b; Tp 7b

(b) 4-5-5—Tc: Cl. IX C; W 20; H 33; I ? (right: narrow hoe and cord—left: ?); B /; Tp 7b

Other examples of mummiform *shabtis* for Tent-tau are found in museums in Brussels,¹ Cairo,² Copenhagen,³ Cortona,⁴ Leiden,⁵ London,⁶ Paris,⁷ St. Gallen,⁸ Stockholm,⁹ Wien,¹⁰ Zurich¹¹ and private collections.

Examples of overseers are to be found in Basel,¹² Cairo,¹³ Chicago,¹⁴ Leiden,¹⁵ Lisbon,¹⁶ London,¹⁷ Madrid,¹⁸ Paris,¹⁹ Roanne,²⁰ Wien²¹ and private collections.

Burial Assemblage

The coffin of these deceased was not identified.²²

Bibliography

Unpublished.

-
- 1 <http://carmentis.kmkg-mrah.be>, E 05412 a–b.
 - 2 Newberry 1957, 303 CG 48239–48248.
 - 3 Mogensen 1918, n. 3931–3932.
 - 4 Botti 1955, 76 n. 82 and 137.
 - 5 Schneider 1977, n. 4.5.1. 31.
 - 6 http://www.britishmuseum.org/research/collection_online, EA 24830.
 - 7 Aubert 1998, n. 46 (Louvre E 32550).
 - 8 Schlögl and Brodbeck 1990, 168 n. 102a.
 - 9 <http://collections.smvk.se/carlotta-mhm>, NME 910.
 - 10 Haslauer 1992, AS 6172.
 - 11 Schlögl and Brodbeck 1990, 168 n. 102.
 - 12 Schlögl and Brodbeck 1990, 202 n. 125a.
 - 13 Newberry 1957, n. 48244–48248.
 - 14 <http://www.artic.edu/aic/collections/artwork/136595>.
 - 15 Schneider 1977, n. 4.5.5.3.
 - 16 Araujo 2003, n. 87.
 - 17 http://www.britishmuseum.org/research/collection_online, EA 24829.
 - 18 MAN 18290–91.
 - 19 Aubert 1998, n. 46.
 - 20 Gabolde 1990, 137 n. 122.
 - 21 Haslauer 1992, AS 6171.
 - 22 Daressy 1907, 17.

44. Shabtis of Dikhonsuiri (*di-hnsw-iry*)

Inv. NN. 8626 and 8627

Cairo List: 17

Daressy List: A.49

Height: (a) 9,8 cm; (b) 9 cm

Raw Material: Light blue faience

State of Preservation: Quite good. The inscriptions are lost.

Description

Mummiform servant.

Face crudely shaped with eyes, brows and lips outlined in black.

Ears modeled over the lappets of the tripartite wig (modeled). Wig adorned with *seshed*-headband.

Arms crossed over the chest grasping the hoes.

Basket on the back.

Iconographic details (headband, hoes and basket) are outlined in black.

Inscription

Painted black. Three horizontal lines of hieratic inscription bounded by two vertical black lines.

“The Osiris Dikhonsuiri”.

Typology

4.3.1—Tc: Cl. VIII A2; W 19; H 1; I 5; B X shaped; Tp 1c (three columns)

Other examples of *shabtis* for Dikhonsuiri are found in museums in Basel,¹ Brussels,² Leiden,³ Lisbon,⁴ Lyon,⁵ Madrid,⁶ Oslo,⁷ Paris,⁸ Roanne,⁹ St. Gallen¹⁰ and private collections.¹¹

Burial Assemblage

The coffins of the “*wab*-priest at the prow of the barque of Khonsu”, “Divine father of Amun-Re”, “Scribe of the Estate of Amun” and “Royal scribe” Dikhonsuiri (A.49) are kept in the Egyptian Museum in Cairo¹² together with his funerary papyrus.¹³ The burial equipment included an Osiris shroud, mummy braces, a heart scarab, a funerary stela¹⁴ and a *shabti*-box now in Florence Museum.¹⁵

Bibliography

Unpublished.

-
- 1 Schlögl and Brodbeck 1990, 198 n. 122a.
 - 2 <http://carmentis.knkg-mrah.be>, E 05413.
 - 3 Schneider 1977, n. 4.3.1. 81–82.
 - 4 Sociedade de Geografia de Lisboa, n. 2507-17 A and B. Araujo 2003, 678–679 n. 80–81. Museu Nacional de Arqueologia, E 103, E 465–466 and E483. Araujo 2003, 738–741 n. 38–41.
 - 5 Dautant et al. 2013, Table 1 n. 17.
 - 6 <http://ceres.mcu.es>, n. 18293.
 - 7 Naguib 1985, EM 8097 and EM 8121.
 - 8 Louvre E 22111.
 - 9 Gabolde 1990, 143 n. 128.
 - 10 Schlögl and Brodbeck 1990, 198 n. 122.
 - 11 Janes 2002, 135–136 n. 70; Aubert 1998, n. 49.
 - 12 Niwiński 1988, 131 n. 141. Outer coffin, inner coffin and mummy-board. Type of the lids 11c, mummy-board in open-work technique. Dating: middle XXI Dynasty (mummy braces of H.P. Pinudjem).
 - 13 Niwiński 1989, 279 n. 73—S.R.VII.10236 (Book of the Amduat between legs, type A.II.1a).
 - 14 Aston 2009, 173 TG. 722.
 - 15 See INV. 8531.

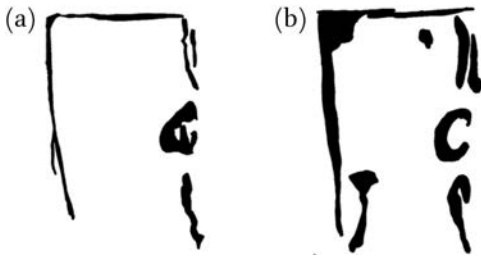

FIGURE 279 Shabtis of Dikhonsuiri (Inscriptions)



FIGURE 280 Shabtis of Dikhonsuiri

45. Shabtis of Djedmaatiuesankh (*dd-Mꜣꜥt-ıw.s-ꜥnh*)

Inv. NN. 8552 and 8553

Cairo List: 30

Daressy List: A.109

Height: (a) 11,6 cm; (b) 11,2 cm

Raw Material: Red pottery painted white.

State of Preservation: Good. In (b) the white paint has almost disappeared.

Description

Mummiform servant.

Face poorly shaped with eyes and brows outlined black.

Ears modeled over the lappets of the tripartite wig (modeled and painted black). The wig is adorned with *shed*-headband painted white.

Arms crossed over the chest grasping the hoes.

Basket on the back.

Iconographic details (hoes and basket) are outlined in black.

Inscription

Painted black. One column of hieroglyphs.

“That may shine the Osiris Djedmaatiuesankh, justified”.

Typology

4.5.1—Tc: Cl. VIII A1; W 17; H 8; I 5; B 14; Tp 7b

Other examples of *shabtis* for Djedmaatiuesankh are found in museums in Basel,¹ Berlin,² Boulogne-sur-mer,³ Cairo,⁴ Copenhagen,⁵ Cortona,⁶ Kazan,⁷

1 Schlögl and Brodbeck 1990, 163 n. 98.

2 Roeder 1913, n. 11970 (two examples).

3 Dautant et al. 2013, Table 1 n. 30.

4 Newberry 1957, 296–297 CG 48141–48149.

5 Mogensen 1918, n. 3919–3920.

6 Botti 1955, 77 n. 102.

7 Berlev and Hodjash 1998, n. 41–42.

Leiden,⁸ Lisbon,⁹ London,¹⁰ Lyon,¹¹ Madrid,¹² Paris,¹³ Roanne,¹⁴ Stockholm,¹⁵ Uppsala¹⁶ and Wien.¹⁷

Burial Assemblage

The coffins of the “Chantress of Amun” and “Mistress of the house” Djed-maatiuesankh, usurped from Tenetwenemheretib, are in the Egyptian Museum in Cairo¹⁸ together with her funerary papyrus.¹⁹ The burial equipment included an Osiris shroud, mummy braces, a wax embalmer’s plaque and two *shabti*-boxes.²⁰

Bibliography

Unpublished.

-
- 8 Schneider 1977, n. 4.5.1. 32–33.
 9 Sociedade de Geografia de Lisboa, n. 2507-30 A and B. Araujo 2003, 680–681 n. 82–83. Museu Nacional de Arqueologia, E 101 and E 415. Araujo 2003, 742–743 n. 42–43.
 10 Petrie 1935, n. 444. http://www.britishmuseum.org/research/collection_online, EA 24857–58.
 11 Dautant et al. 2013, Table 1 n. 30.
 12 MAN 18318–19.
 13 Aubert 1998, n. 50 (Louvre E 22052).
 14 Gabolde 1990, 143–144 n. 129.
 15 <http://collections.smvk.se/carlotta-mhm>, NME 913.
 16 Sandman 1931, 104–105 n. 27–28.
 17 Haslauer 1992, AS 6151 and AS 8794.
 18 Niwiński 1988, 123 n. 103. Outer coffin, inner coffin and mummy-board. Type of the lids 11b. Dating: middle XXI Dynasty (mummy braces of H.P. Menkheperre).
 19 Niwiński 1989, 256 n. 8—S.R.IV. 542 (JE 95645—Book of the Amduat, type A.III.1b).
 20 Aston 2009, 183 TG. 782.

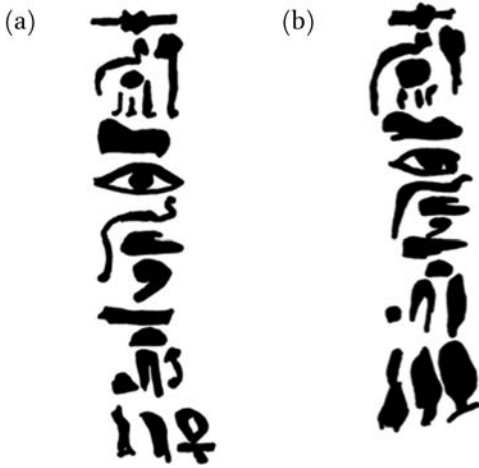

FIGURE 281 Shabtis of Djedmaatuesankh (Inscriptions)



FIGURE 282 Shabtis of Djedmaatuesankh

46. Shabtis of Djedmut (*dd-Mwt*)

Inv. NN. 8566 and 8567

Cairo List: 9

Daressy List: A.110

Height: 00 cm

These two objects (INV. 8566–8567) are recorded as “lost” in the Museum Catalogues from the Seventies onwards, nevertheless they are found, but almost completely destroyed.

Some information can be found in the Manuscript Catalogues of A. Pellegrini and G. Botti, who were able to read the name Djedmut (as for N.Inv. 8566 Pellegrini was confused in reading the bird-sign, Gardiner G5 instead of Gardiner G14, so he gave the name Djedhor).

Furthermore the matching is simplified thanks to the comparison with other samples of the same series in other collections (see below).

Inscription

Following the comparisons, the inscription was painted black, in one column of hieroglyphs saying
“That may shine the Osiris Djedmut, justified”.

Following L. Aubert, other examples of this series of *shabtis* are those found in Cairo.¹

Burial Assemblage

Following L. Aubert, the name Djedmut is a short version of the name Djedmutiusankh relating to the deceased A.45 buried in the Second Cache.² This Chantress of Amun had a coffin now in the Archaeological Museum in Istanbul.³ The deceased was supplied with an Osiris shroud, linen socks, linen mittens and a wax embalmer’s plaque.⁴

Bibliography

A. Pellegrini, Bessarione VII (1899–1900), p. 38 n. 225.

1 Newberry 1957, 289–290 CG 48074–86.

2 Aubert 1998, 107. Indeed the scholar records the N.Inv. 8566 from Florence among the samples of this serie.

3 Niwiński 1988, 143 n. 210. Inner coffin, type IIIa of the lid. Dating: middle/late XXI Dynasty.

4 Aston 2009, 172 TG. 718.

47. Illegible Shabti

Inv. N. 8614

Cairo List: ?

Daressy List: ?

Height: 6,5 cm

Raw Material: Blue faience

State of Preservation: Good. Broken on the rear of the head and on the right elbow.

Description

Mummiform servant.

Features of the face fairly shaped with eyes and brows outlined in black.

Ears modeled over the lappets of the tripartite wig (modeled and striated). The wig is adorned with a *seshed*-headband.

Arms crossed over the chest grasping the hoes.

Basket on the back.

Iconographic details (headband, hoes and basket) are outlined in black.

Inscription

Painted black. One column of hieroglyphs, difficult to read.

“That may shine the Osiris?”.

Typology

4.3.1—Tc: Cl. VIII A2; W 25 (or 26); H 8; I 5; B 16; Tp 7b

Bibliography

Unpublished.



FIGURE 283
Illegible shabti (Inscription)



FIGURE 284 Illegible shabti

Table of Concordances

Catalogue number	Name of the deceased	Shipping document (1893)	Florence inv. number	Daessy list
1	<i>ꞑsty</i>	12	8594–8595	A 66
2	<i>ꞑst-m-ꞑh-bit</i>	4	8542–8543	A 126
3	<i>ꞑst-m-ꞑh-bit</i>	26	8586–8587	A 126
4	<i>Īmn-hꞑt-pꞑ-mš^c</i>	5	8616–8617	A 124
5	<i>Īmn-hꞑt</i>	10	8548–8549	A 39
6	<i>ꞑh.f-n-Mwt</i>	13	8536–8537	A 140
7	<i>ꞑh.f-n-hꞑsw</i>	1	8558 8610–8611	A 33
8	<i>ꞑh.f-n-hꞑsw</i>	27	8559	A 108
9	<i>ꞑh.s-n-Mwt</i>	33	8541 8562–8563	A 38
10	<i>ꞑh.s-n-Mwt</i>	34	8540	A 38
11	<i>Wsr-hꞑt-ms</i>	7	8596–8597	A 105
12	<i>Bꞑk-n-Mwt</i>	18	8546–8547	A 94
13	<i>Pꞑy.f-ꞑdr</i>	22	8579	A 99
14	<i>Pꞑ-hꞑrw</i>	39	8624–8625	A 115
15	<i>Pꞑ-sbꞑ-hꞑ-n-niwt</i>	20	8550–8551	A 85
16	<i>Pꞑ-di-Īmn</i>	3	8560–8561	A 114
17	<i>Pꞑ-di-Īmn</i>	45	8588–8589	A 24
18	<i>Mr.t-Īmn</i>	8	8570–8571	A 71
19	<i>Mr.t-Īmn</i>	14	8608–8609	A 71
20	<i>Mr.t-Īmn</i>	35	8592–8593	A 71
21	<i>Ns-Īmn</i>	38	8606–8607	A 148
22	<i>Ns-Īmn-m-ipt</i>	31	8598–8599	A 113
23	<i>Ns-pꞑ-hꞑr-ꞑn</i>	46	8584–8585	A 35
24	<i>Ns-pꞑ-hꞑr-nꝼr</i>	43	8568–8569	A 98
25	<i>Ns-pꞑ-kꝼ-šw.ti</i>	25	8590–8591	A 43
26	<i>Ns-Mwt</i>	32	8538–8539	A 48
27	<i>Ns-hꝼsw</i>	44	8554 8556	A 42
28	<i>Ns-tꝼ-wdꝼ.t-ꝼht</i>	19	8620 8600–8601	A 96

(cont.)

Catalogue number	Name of the deceased	Shipping document (1893)	Florence inv. number	Daressy list
29	<i>Ns-tz-nb(.t)-tz.wy</i>	2	8576-8577	A 77
30	<i>hnw.t-tz.wy</i>	29	8544-8545	A 64
31	<i>hr</i>	37	8572-8573	A 143
32	<i>hryt-wbht</i>	15	8564-8565	A 133
33	<i>h^z.s</i>	21	8612-8613	A 102
34	<i>hnsw-m-hb</i>	42	8582-8583	A 106
35	<i>hnsw-ms</i>	24	8580-8581	A 82 OR A 121
36	<i>Šd-sw-İmn</i>	23	8618-8619	A 30
37	<i>G^zwt-sšnw</i>	41	8615	A 152
38	<i>t^z-b^zk-n-hnsw</i>	28	8604-8605	A 10
39	<i>t^z-šd-hnsw</i> or <i>dnt-šd-hnsw</i>	11	8557 8578	A 137
40	<i>dnt-šd-hnsw</i> or <i>Šd-t^z-hnsw</i>	36	8555 8621	A 137
41	<i>t^z-di.t-Mwt</i>	6	8574-8575	A 91
42	<i>t^z-nfr</i>	40	8622-8623	A 151
43	<i>tnt-tz.wy</i>	16	8602-8603	A ?
44	<i>di-hnsw-iry</i>	17	8626-8627	A 49
45	<i>dd-M^zt-iv.s-^znh</i>	30	8552-8553	A 109
46	<i>dd-Mwt</i>	9	8566-8567	A 110 (?)
47	?	?	8614	?

SECTION 3

Shabti-Boxes

M. Cristina Guidotti and Deborah Vannucci



Introductory Notes

Ancient Egyptian funerary equipment is characterised, from the Second Intermediate Period onwards, by the presence of shabtis, often stored inside containers.¹

During the Second Intermediate Period, shabtis were placed inside a small sarcophagus in wood or clay, imitating the real rectangular sarcophagus with vaulted lid and raised short sides at a smaller scale.

In the New Kingdom, recipients for shabtis were given anthropoid shape, decorated with bands of hieroglyphs and images of divinities. In that period the first boxes shaped as shrines appeared, sometimes placed on wooden sleighs. These cases are square shaped, with two sides raising over the vaulted lid, secured by ropes to tie the knobs placed on the box and on the lid. Boxes with two, three or four lids also existed; they were internally divided in sections by straight rectangular or squared partitions. Each compartment was closed by a lid and contained one or two standing shabtis.

The walls were externally decorated with images of the deceased or offering scenes.

At the beginning of the Ramesside Period boxes in shape of a double or triple shrine appeared, each shrine containing two or more shabtis.

During the Third Intermediate Period the box was crafted without inner partitions, maintaining the multiple lids. The walls were externally painted with scenes depicting the deceased in front of Osiris, the four Sons of Horus, and many divine symbols such as *udjat* and *nefer*-signs. Particularly during the 21st and 22nd Dynasties the boxes were mainly rectangular or square-shaped, decorated with bands of hieroglyphic inscriptions outlined in black, directly on wood or on a coat of paint.

The three shabti-boxes from Bab el-Gasus kept at the Egyptian Museum of Florence and belonging to Lot v fit into this last typology of objects.

1 On shabti-boxes, see Aston 1994. See also Marini 2012.

Shabti-Box of Heritubekhet (*ḥryt-wbḥt*)

Inv. N. 8529

Material: Painted wood.

Height: 38 cm; **Width:** 54,2 cm; **Depth:** 33 cm

Description

Rectangular shabti-box, closed by three vaulted lids, each one flanked by shelves; one knob and one pin on each lid.

On the front side are three knobs, one in correspondence with each lid. In the centre there is a hieroglyphic inscription painted in black on a yellow background, arranged on four columns in black, marked above by a blue band. The rest of the box bears no inscription nor decoration. The interior is not divided in sections.

It is noteworthy that Lot v also includes two shabtis for Heritubekhet (inv. nn. 8564 e 8565).

Inscription

- 1 “Words said by Osiris, lord of the Duat, in order that he gives her an offer”
- 2 “The Osiris, the lady of the house, chantress of Amun-Re, king of gods”
- 3 “The Second Prophetess of Mut, Heritubekhet, justified”
- 4 “Daughter of Asetemakhbit”

Condition

On the left lid and central lid the knob is missing. On the front side in correspondence with the central lid a hole is visible where the knob was originally placed. The left shelf is broken.

Bibliography

Porter and Moss, 1, 2, 635–641; Marini 2012, 103–105, fig. 16.



FIGURE 285 Shabti-box of Heritubekhet

Shabti-Box without Inscriptions

Inv. N. 8530

Material: Painted wood.

Height: 57 cm; **Width:** 61 cm; **Depth:** 33 cm

Description

Rectangular shabti-box placed on a plinth, closed by three flat lids, each one flanked by shelves; a knob on each lid.

No decoration, nor inscription.

No internal partitioning.

Condition

The central lid is missing. On the front side in correspondence with each lid a hole is visible where the knob was originally placed. The front side and one of the short sides are perforated.

Bibliography

Marini 2012, 105, fig. 17.



FIGURE 286 Shabti-box (uninscribed)

Shabti-Box of Dikhonsuiri (*dî-ḥnsw-iry*)

Inv. N. 8531

Material: Painted wood.

Height: 43,5 cm; **Width:** 64,5 cm; **Depth:** 34 cm

Description

Rectangular shabti-box, tapered upwards, closed with three vaulted lids, each one flanked by shelves. On each lid there is a knob. An inscription painted in black on a yellow background, marked by a framed column, runs vertically on each lid.

On the front side are three knobs, one in correspondence with each lid. Three inscriptions painted in black on yellow, each marked by a framed column, run vertically under each lid.

On the opposite side and both short sides there are no inscriptions, nor decorations.

No internal partitioning.

It is noteworthy that Lot v also includes two shabtis for Dikhonsuiri (inv. nn. 8626 e 8627).

Inscriptions

A single text is repeated six times:

“Osiris, divine father of Amun-Re, king of gods, the scribe of the temple of Amun, Dikhonsuiri”

Condition

On the left lid the knob is missing; central lid and the right one are broken. Left shelf is broken.

Bibliography

Porter and Moss, I, 2, 641; Marini 2012, 102–103, fig. 15.



FIGURE 287 Shabti-box of Dikhonsuiri

PART 2

Essays



The Reconstruction of the Burial Assemblages from Lot v

Marianna Zarli

The starting point for reconstructing the burial assemblages included in Lot v is the report by Daressy published in 1907,¹ based on his own notes.²

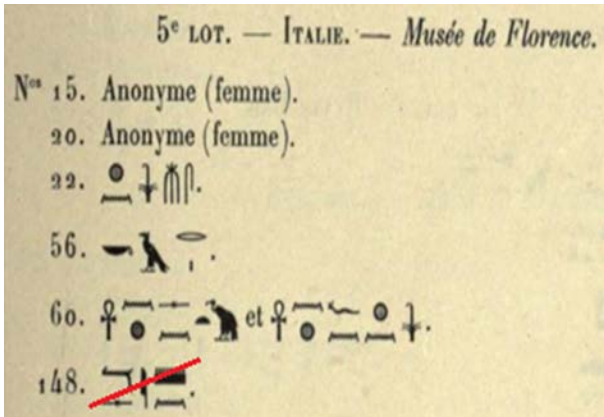

FIGURE 288 Lot v after Daressy 1907

According to this report the Egyptian Museum of Florence received six coffin sets. However, the coffin set from A.148 never left Egypt, still being stored in the Egyptian Museum in Cairo.³ Nevertheless the other five coffin ensembles arrived in Florence in relatively good condition and were given the inventory numbers from 8521 to 8528.

Three of the ensembles are easy to ascribe to their owners: A.22 was prepared to be used by Khonsumes, A.56 belonging to Karo and A.60 belonging to Ankhesenmut et (e.g. 'usurped from') Ankhefenkhonsu. The remaining two (A.15 and A.20) were anonymous.

Among later authors who dealt with the subject, Andrzej Niwiński visited Florence trying to match the numbers of the A.List with the objects stored

¹ Daressy 1907, 19.

² See Lieblein 1892, 993–1004.

³ Niwiński 1988, 118 n. 79.

in the Museum. Unfortunately most of the objects were stocked in the Museum's storerooms and difficult to access at the time. Because of that the author's reconstruction presents some mistakes.⁴

A.60 - N.INV. (among others) 8523 Outer coffin + inner coffin + Mummy-cover Ankhesenmut usurped from Ankhefenkhonsu
A.15 - N.INV. probably 8524 and others Anonymous Chantress of Amun - name found on the mummy Djedmutiusankh
A.20 - N.INV. probably 8525 and others Anonymous Chantress of Amun - name found on the mummy Nesitanebisher[---]
A.56 - N.INV. probably 8526 Karo, Priest of Amun
A.22 - N.INV. 8527 (and 8528?) Khonsumes, Scribe of the Estate of Amun

FIGURE 289 Lot v after Niwiński 1988

Some of the same mistakes are also detected in the publication by David Aston.⁵

4 Niwiński 1988, 139–140, n. 189–194. The coffin set from A.60 is said to be formed by the outer coffin N.Inv. 8523 and others, e.g. inner coffin (N.Inv. 8526) and mummy-cover (N.Inv. 8521) not identified. As for the coffin set from A.15, only the outer coffin N.Inv. 8524 is listed and given as probable, while the inner coffin (N.Inv. 8528) and the mummy-cover (N.Inv. 9534) remain unidentified. The outer coffin N.Inv. 8525 was ascribed to the coffin set from A.20, but this ensemble is actually formed by the inner coffin N.Inv. 8522 and the mummy-cover N.Inv. 9476. At the same time the outer coffin N.Inv. 8525 (and not the inner coffin N.Inv. 8526 as claimed by Niwiński) belongs to the burial A.56. The inner coffin N.Inv. 8527 and the mummy-cover N.Inv. 9530 (and not the inner coffin N.Inv. 8528) form the coffin set from A.22. Finally, as said, the mummy-cover N.Inv. 9534 listed with unknown provenance comes from Bab el-Gasus and is part of the coffin set from A.15. It is worthy to note that on p. 139 the author himself points out the difficulties encountered.

5 Aston 2009, 164–198.

A.15 Chantress of Amun, DJEDMAATIUSANKH - Florence 8524?
A.20 TAUHENUT - Florence 8525?
A.22 Scribe of the Estate of Amun, KHONSMOSE - Florence 8527
A.56 Priest of Amun, KARO - Florence 8526
A.60 ANKHESENMUT - Florence 8521–8523

FIGURE 290 Lot V after Aston 2009

Nevertheless, two important notices were added: first the name of the deceased in A.20⁶ and second the discovery that N.Inv. 8521 and 8522 match with the N.Inv. 8523.⁷

However, the most important document for the reconstruction of the original burial ensembles belonging to Lot V is the original list of antiquities, as it was set up in Giza before the objects were sent to Italy. This list is kept in the Museum Archives (Document number 7, cited in the Introduction by Maria Cristina Guidotti).

Relating to the coffins we read:

Cinquième Lot

N.° 29691.15.16

Très beau cercueil d'une chanteuse d'Ammon dont le nom est effacé partout.

La décoration du petit cercueil intérieur est remarquable. Le disque entre les cornes d'une tête de taureau, qui porte au front un triangle noir; les autres taches sont disposées de manière à imiter à peu près la forme du scarabée. La décoration extérieure du même cercueil est très intéressante.

À l'intérieur du grand cercueil on remarque le disque contenant le signe de l'âme et l'œil symbolique, posté, comme précédemment entre les cornes du taureau. Un serpent roulé sur lui même enveloppe un personnage à

6 This information is taken from the old publication of the unwrapping of the mummy itself made by Daressy and Smith 1903, 155 and 160.

7 Indeed, this correspondence has been first noted by Niwiński, that in Table II at the end of his Volume associates the numbers 8521 and 8522 to the number 8523 (see Niwiński 1988, 200).

tête de lièvre, tenant de chaque main une plume d'autruche. La décoration extérieure est aussi très remarquable.

N.° 29701.60

Grand Cercueil de la dame chanteuse d'Ammon "Ankhseteninaut" Il avait appartenu à "Ankhefkhonsou" dont le nom est mal effacé. Intéressant.

N.° 29676

Cercueil de Khonsoumès, scribe de la maison d'Ammon.





N.° 29644

Cercueil

N.° 20.25

Cercueil

After a careful reading of the sources, we turned our attention to the material evidence, focusing the object of our inquiry in the storerooms of the Museum, where most of the findings belonging to Lot v were preserved. Thanks to the kind support of Director M.C. Guidotti, we had full access to the complete group of objects, from which resulted the following list:

Inv. Florence	Typology of the object	Name and titles on the object
8521	Mummy-cover	 Chantress of Amun
8522	Inner coffin (lid + case)	Anonymous (F) Chantress of Amun
8523	Outer coffin (lid + case)	 Usurped from 
8524	Outer coffin (lid + case)	Anonymous (F) Chantress of Amun
8525	Outer coffin (lid)	Anonymous (M) Priest of Amun and Scribe
8526	Inner coffin (lid + case)	Anonymous (F) Chantress of Amun
8527	Inner coffin (lid + case)	 Scribe of the Estate of Amun
8528	Inner coffin (lid + case)	Anonymous (F) Chantress of Amun

All these objects are recorded in the “Manuscript Catalogues of the Museum” and were known to come from Bab el-Gasus as a gift from the Egyptian Government.

Based on the examination of the material evidence we established the following matches.

1 N.° 29691.15.16

There is no doubt about the identification of the numbers detected on this object: 29691 is the entry number of the *Journal d'Entrée* of the Egyptian Museum in Cairo, 15 refers to Daressy 'A.List' while 16 to Bouriant 'B.List'.

The description of the inner coffin (*petit cercueil interieur*) decoration fits perfectly with the interior decoration of the inner coffin N.INV. 8528. At the same time the description of the outer coffin (*grand cercueil*) corresponds exactly with the interior decoration observed on the outer coffin N.Inv. 8524.

We thus have the full identification of a four-piece ensemble (lids and cases) belonging to the anonymous woman buried in the coffin set A.15. Besides, we can include in this burial assemblage a fifth piece, the mummy-cover: without any doubt N.Inv. 9534.⁸ In this case the decoration of the object follows very closely the scheme detected on the lid of the inner coffin (N.Inv. 8528).

Only one problem remains to be solved: the *Journal d'Entrée* (JE) number. Document n. 7 states the number 29691, while the report published by Daressy in 1907 gives the number 29695.⁹ This discrepancy could have been the result of a typing error that occurred during the edition of the text, so we decided to trust in Document 7 (compiled soon after the discovery) and maintain the number J.E. 29691.

To summarize, we have the following situation:

8 Niwiński 1988, 140 n. 194.

9 Daressy 1907, 5.

A list	B list	Inv. Florence	Journal d'Entrée	Niwiński	Typology of the object	Name and titles on the object
15	16	8524	29691	190	Outer coffin (lid)	Anonymous (F) Chantress of Amun
15	16	8524	29691	190	Outer coffin (case)	Anonymous (F) Chantress of Amun
15	16	8528	29691	193	Inner coffin (lid)	Anonymous (F) Chantress of Amun
15	16	8528	29691	193	Inner coffin (case)	Anonymous (F) Chantress of Amun
15	16	9534	29691	194	Mummy-cover	Anonymous (F) Chantress of Amun

2 N.° 29701.60

The words '*grand cercueil*' led us to speculate that we are dealing with an outer coffin. Indeed, the name Ankhefekhonsu appears in the hieroglyphic texts on the case of the outer coffin N.Inv. 8523. This is a male outer coffin (striped wig, closed hands and hole on the chin for the joint of the beard), so no doubt about the identification of this object with part of the burial equipment of the deceased A.60 of Daressy List. Furthermore Niwiński matches the objects N.Inv. 8521 and 8522 with the number 8523 and Daressy records that the name Ankhesenmut was read on the '*planche intérieure*' of the coffin set A.60.¹⁰

Actually the name Ankhesenmut appears in the inscriptions of the mummy-cover N.Inv. 8521 and leads us to uphold the matching. The material evidence confirms the speculation of reuse proposed in the document sources: on the mummy-cover the striped wig was re-painted black and painted earrings were added below the ears in sight; the breasts were painted below the lappets of the wig and the hands were replaced (in fact the open hands are disproportionate to the general layout of the object).



As for the inner coffin, unfortunately we cannot match the inner coffin N.Inv. 8522 with those objects, because it surely does not belong to the coffin ensemble A.60 (see below).

¹⁰ Daressy 1907, 27.

Looking for an inner coffin to associate with the outer coffin and the mummy-cover, only the female anonymous coffin N.Inv. 8526 is left (in fact N.Inv. 8528 belongs to A.15 and N.Inv. 8527 bears another name—see below).

However the matching of N.Inv. 8521–8522–8523 creates noticeable problems. First of all, the three components are of very different styles and seem to have been produced in different workshops in different times, certainly not for the same woman. In fact as we have seen the outer coffin was usurped from a man (though the lid still maintains its male characters, we can notice that in the inscriptions of the case the name Ankhefenkhonsu was erased to overwrite that of the new owner). The same can be said about the mummy-cover. As for the inner coffin, it has female features but is anonymous (the space reserved for the deceased name was left blank), so we can only speculate if it was reused or commissioned by the deceased.

The mismatch is further corroborated by the typological and consequently chronological comparison: the outer coffin dates to the end of the 21st Dynasty (type of the lid III-a, type of the case C/3c), while the inner coffin shows traces of archaization (type of the lid between IIa and IIc, type of the case A/2a) and the mummy cover dates to the first half of the 21st Dynasty.¹¹ In conclusion, the components of this coffin ensemble appear to have been scrambled together from various sources and reused for the burial of Ankhesenmut.

A list	B list	Inv. Florence	Journal d'Entrée	Niwiński	Typology of the object	Name and titles on the object
6o	–	8523	29701	189	Outer coffin (lid)	Anonymous (M)
6o	–	8523	29701	189	Outer coffin (case)	♀  Usurped from ♀ 
6o	–	8526	–	192	Inner coffin (lid)	Anonymous (F) Chantress of Amun
6o	–	8526	–	192	Inner coffin (case)	Anonymous (F) Chantress of Amun
6o		8521	–	–	Mummy-cover	♀  Chantress of Amun

¹¹ For the classification criteria see Niwiński 1988, 65–99.

3 N.° 29676

'*Cercueil de Khonsoumès, scribe de la maison d'Ammon*'. The matching seems to be unquestioned, giving that the inscriptions of the lid of the N.Inv. 8527 display the name and the titles of Khonsumes.

While lacking in Document 7, the matching of the number A.22 of Daressy List with a deceased called Khonsumes is confirmed by all the sources.¹² As for the entry in the *Journal d'Entrée* of the Cairo Museum, two J.E. numbers are associated with the coffin of Khonsumes and this matching is confirmed by all the sources:¹³ 29676 and 29731. The fact that in Document n. 7 only the number 29676 appears could mean that

- 1) The same coffin was given two numbers (one for the lid and another one for the case) or
- 2) The funerary equipment of Khonsumes consisted in two pieces (outer + inner coffin or inner coffin + mummy cover) and the second object was lost.

It should be remarked that the inner coffin N.Inv. 8527 has been later modified for a woman: the ears were covered and earrings were added in paint; the closed hands were replaced with open ones (now lost).

This situation led us to consider the features of a female mummy-cover preserved in the Florence Egyptian Museum, namely N.Inv. 9530. Its decoration strikingly recalls the decoration of the lid N.Inv. 8527, but this resemblance was never considered because the mummy-cover 'clearly' belonged to a woman and its provenance was unknown.¹⁴



Once more the material evidence led us to speculate that this mummy-cover was a part of the coffin ensemble A.22 and suffered the same fate of the inner lid: indeed even here we can detect the traces of reuse, with the covering of the ears, the painting of the earrings and the adding of the open hands. But the clearest evidence of the reuse is to be noticed in the lower part of the inscriptions of the mummy-cover: here the title and the name of the male deceased (Khonsumes) was clearly erased to overwrite the title (mistress of the house) and the name (now lost) of the female usurper.

12 See Daressy 1907, 5; Extrait 1891, 365 and 369; El-Shater 1987, 264 and 266.

13 See the references above.

14 In truth the suggestion of G. Botti should be cited. In his manuscript catalogue of the Egyptian Collection of the Florence Museum he considered the mummy-cover, giving it an inventory number (exactly 9530) and suggesting that it could have been part of the gift of the Egyptian Government.

To conclude, the final setting up of the coffin ensemble A.22 results as follows:

A list	B list	Inv. Florence	Journal d'Entrée	Niwiński	Typology of the object	Name and titles on the object
22	29	8527	29676 or 29731	193	Inner coffin (lid)	 Scribe of the Estate of Amun
22	29	8527	29676 or 29731	193	Inner coffin (case)	 Scribe of the Estate of Amun
22	29	9530	29676 or 29731	–	Mummy-cover	Anonymous (F) Usurped from 

4 N.^o 29644

The word '*cercueil*' is not useful for a match, but if we consider the number (clearly the J.E. number) this object can be associated with the number A.56 of Daressy List¹⁵ and with the funerary equipment of a priest of Amun named Karo.

The only male object of the Lot v, apart from that of Khonsumes, is the N.Inv. 8525. Following the material evidence one would expect to notice a coffin, but unfortunately we found just an anonymous male outer lid on which only the titles 'Priest of Amun' and 'Scribe' appear. How about the case? Is it lost? Luckily it is not so. After a careful search within the museum collection we found a case on display in room VIII of the Egyptian Museum of Florence. It was anonymous¹⁶ and without inventory number, but according to some stylistic consideration it could be matched with our lid: both the lid and the case are 2,12 m long; the painted decoration of the case, showing an iconography influenced by the Books of the Netherworld, fits perfectly with the decoration of the lid (I11a) dating from the end of the pontificate of Menkheperra to the end of the 21st Dynasty.

¹⁵ Daressy 1907, 8 and 19.

¹⁶ The space reserved for the name of the deceased was left blank.

But how about the name? All the textual sources agree in recording that the name of the deceased buried in A.56 was Karo,¹⁷ but following the material evidence the outer coffin N.Inv. 8525 is anonymous. In such a situation, the name Karo must have been written elsewhere, that could be

- 1) A further component of the burial assemblage (inner lid or mummy-cover) or
- 2) The mummy of the deceased itself

We searched long in the storerooms for a further coffin or a mummy-cover that could fit with the outer coffin A.56, but with no results. Maybe the object was lost during the shipping, or never left the Cairo Museum, or even it might have been shipped elsewhere with a different lot.

Therefore, for now the setup of A.56 is as follows:

A list	B list	Inv. Florence	Journal d'Entrée	Niwiński	Typology of the object	Name and titles on the object
56	77	8525	29644	191	Outer coffin (lid)	Anonymous (M) Priest of Amun and Scribe
56	77	[8525]	29644	191	Outer coffin (case)	Anonymous (M)

5 N.° 20.25

In light of the above, only the inner coffin N.Inv. 8522 has to be matched.

This female coffin is anonymous, but its matching could not be more specified: on the headboard of the lid, precisely in the part corresponding to the neck, we noticed a little tally inscribed with the number '20.25': this can only refer to the numbers A.20 and B.25.

In Document n. 7 there is no mention about other objects pertaining to this funerary ensemble. Nevertheless in the Museum storerooms we found a female mummy-cover that could fit with our coffin. N.Inv. 9476 is anonymous and its provenance is unknown.

¹⁷ Extrait 1891, 363 ('*cercueil avec la momie de Karo*'); Lieblein 1892, 996 ('*Karo*'); Daressy 1907, 8 and 19; El-Shater 1987, 263 ('*mummie of Karo*').

Following the material evidence we noticed striking affinities in the decoration of the two lids (the panels with *udjat*-eyes that adorn the forearms; the shape of the sacred scarab, with the head perfectly distinguished from the corpse; the first part of the inscriptions, with the use of the same composition, the same words, the same signs and even the same colours).

In conclusion, this is the setup of the coffin ensemble A.20:

A list	B list	Inv. Florence	Journal d'Entrée	Niwiński	Typology of the object	Name and titles on the object
20	25	8522	–	–	Inner coffin (lid)	Anonymous (F) Chantress of Amun
20	25	8522	–	–	Inner coffin (case)	Anonymous (F) Chantress of Amun
20	–	9476	–	–	Mummy-cover	Anonymous (F)

Summarizing the results of our study on the coffin ensembles of Lot v, the Egyptian Museum of Florence received two complete coffin sets, two inner coffins with mummy-cover and an outer coffin.

To give a general view of the findings we present a Table of Concordances, concerning the concordances between the Inventory Number of the Egyptian Museum of Florence (INV.Florence), the number of the 'A.List' given by Daressy,¹⁸ the number of the 'B.List' by Bouriant,¹⁹ the number of the *Journal d'Entrée* of the Cairo Egyptian Museum and the number of each coffin in the fundamental publication of Niwiński.²⁰ The reference is completed by notes about the typology of the object and name and titles detected on it. Finally the corresponding number of the present Catalogue is given.





The entries listed in the Catalogues of the Florence Egyptian Museum are given in plain black, while the new entries identified after this study are given in bold black.

¹⁸ Daressy 1907, 5–14.

¹⁹ Never published separately, but cited in the A.List published by Daressy (see above).

²⁰ Niwiński 1988, 104–184.

Table of Concordances

A list	B list	Inv. Florence	Journal d'Entrée	Niwiński	Typology of the object	Name and titles on the object	N.Cat.
15	16	8524	29695	190	Outer coffin (lid)	Anonymous (F) Chantress of Amun	1
15	16	8524	29695	190	Outer coffin (case)	Anonymous (F) Chantress of Amun	2
15	16	8528	29695	193	Inner coffin (lid)	Anonymous (F) Chantress of Amun	3
15	16	8528	29695	193	Inner coffin (case)	Anonymous (F) Chantress of Amun	4
15	16	9534	29695	194	Mummy-cover	Anonymous (F) Chantress of Amun	5
20	25	8522	—	—	Inner coffin (lid)	Anonymous (F) Chantress of Amun	6
20	25	8522	—	—	Inner coffin (case)	Anonymous (F) Chantress of Amun	7
20	—	9476	—	—	Mummy-cover	Anonymous (F)	8
22	29	8527	29676 29731	193	Inner coffin (lid)	 Scribe of the Estate of Amun	9
22	29	8527	29676 29731	193	Inner coffin (case)	 Scribe of the Estate of Amun	10
22	29	9530	29676 29731	—	Mummy-cover	Anonymous (F) Usurped from 	11
56	77	8525	29644	191	Outer coffin (lid)	Anonymous (M) Priest of Amun and Scribe	12
56	77	8525	29644	191	Outer coffin (case)	Anonymous (M)	13
60	—	8523	29701	189	Outer coffin (lid)	Anonymous (M)	14
60	—	8523	29701	189	Outer coffin (case)	 Usurped from 	15

(cont.)

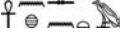
A list	B list	Inv. Florence	Journal d'Entrée	Niwiński	Typology of the object	Name and titles on the object	N.Cat.
6o	-	8526	-	192	Inner coffin (lid)	Anonymous (F) Chantress of Amun	16
6o	-	8526	-	192	Inner coffin (case)	Anonymous (F) Chantress of Amun	17
6o		8521	-	-	Mummy-cover	 Chantress of Amun	18

Coffin Reuse in the 21st Dynasty: a Case Study of the Bab el-Gasus Coffins in the Egyptian Museum of Florence¹

Kathlyn M. Cooney

In this contribution, I will lay out detailed evidence for reuse of coffins in the Egyptian Museum of Florence coming from the Second Deir el Bahari Cache of Bab el-Gasus and dating to the 21st and early 22nd Dynasties. It was at this point in history when the whole of the Mediterranean region went through a massive economic and social collapse, seeing the fall of the Mycenaean, Hittite, Ugaritic and other civilizations. This regional event did not bring about Egypt's fall, but it did bring with it disruptions in Egypt's centralized government, economic systems, agriculture, trade networks, not to mention an influx of Sea Peoples and Libyans in mass migrations. Government systems in the north of Egypt faltered, while in Thebes people moved on without a king, relying only on a decentralized High Priesthood of Amun to maintain order.² The material culture of the Theban region is a testament to this moment in history.

Coffins are social documents, recording social place, gender, spending ability, geographic place, commodity availability, craft details, and religious information. Coffins can reflect human reactions to all sorts of changes in the environment and within human systems, including reactions to scarcity and crisis. In fact, using coffins to gauge the severity of a social crisis might be a better indicator than official texts with a state agenda of cracking down on opportunists or presenting an image of control. During the New Kingdom and Third

1 There are many people I need to thank for facilitating my research in Florence, not least among them Maria Cristina Guidotti, who is curator there and who facilitated not one, but two visits. I would also like to thank Elsbeth Geldhof, once a conservator with duties at the Rijksmuseum and now my chief partner-in-crime when investigating coffins for reuse, and, more importantly, proving the reuse with all of her many tools. Remy Hiramoto facilitated the photography, both infrared and conventional, and I could not have done the work without him. Amber Myers Wells has been an indispensable research assistant, and no article of mine would be complete without her help with tables, graphs, and spreadsheet number crunching. Finally, I would like to thank Rogério Sousa, without whom this publication of the Florence coffins would not have been possible.

2 Reeves 1990. See also Taylor 1992.

Intermediate Period, Egyptians with disposable income were meant to have a nesting coffin set made—for their death, for their display in the funeral cortège, transformation in burial rites, and, ostensibly, for their use in the hereafter in perpetuity. When the ancient Egyptians entered a period of scarcity and collapse, they were loath to abandon the physicality of their coffins, and Theban elites in particular continued their materialist understanding of funerary practices creating coffins with brightly painted polychrome decorations. How did the Egyptians maintain coffin production despite scarcity of resources, known to us from other texts and sources?

When I first started my dissertation in 1999, I set out to find all examples of Ramesside coffins in museums in Europe, North America, and Egypt. There were only about 80 examples, including small fragments,³ and this, despite the fact that the first part of the Ramesside Period was characterized by prosperity, including empire building, the astounding construction program of Ramses II, the apex of the Deir el Medina craft production in the Valley of the Kings, and intensive funerary commissions by elites in Western Thebes. Despite the evidence for significant elite funerary production from the reigns of Ramses I to Ramses III, very few coffins can be attributed to the 19th Dynasty and even fewer to the 20th Dynasty. Where have all the Ramesside coffins gone? It was Andrzej Niwiński who first suggested that many such coffins were actually reused in the ensuing 21st Dynasty⁴ when social and governmental systems decentralized and when evidence for economic scarcity is everywhere in the written and archaeological record, but there was no systematic study of the topic of reuse.

Identifying reuse on later coffins of the 21st Dynasty can be very difficult. Unless one is specifically looking for it, reuse can hide in plain sight, partly because we consider coffin reuse aberrant and do not expect to see it, but also because the Egyptians became very skilled at creating new coffins out of old. The reusers of the Bab el-Gasus coffins had become particularly adept at reusing so that new, updated decoration blended into the old colours, even if two decoration styles occurred on one and the same coffin surface.

Mine is the first study to systematically identify evidence of coffin reuse in any time period in ancient Egypt and the findings continue to surprise Egyptologists. Because we are moving from a phase of prosperity to one of scarcity in

3 Cooney 2007. This research focused mainly on Theban coffins, but I have added many more 19th and 20th Dynasty coffins from northern contexts to the growing list, which appeared in Cooney 2018. See also Cooney 2017.

4 Niwiński 1988, 57.

the 21st Dynasty, the study of coffin reuse must view trends as they change over time and employ a large dataset. The larger the dataset, the more reliable the study's conclusions about trends of reuse will be. Thus, I set out with an interdisciplinary team of experts to examine as many coffins of the 19th–21st Dynasties and early 22nd Dynasty as possible, looking under breaks in the plaster for older decoration, examining the spots where personal names were written for evidence of re-inscription, carefully checking for out-of-fashion wooden modeled feet or forearms underneath the current plaster surface.

There were many ways to reuse a coffin. Sometimes, only the old name was removed and a new one added. Many other coffins indicate that craftsmen updated funerary pieces in a piecemeal fashion, keeping some elements and re-working others—retaining an older style wig, for example, covering it over with blue paint only, but updating the collar and lower body. Or, in other cases, I have been able to identify forearms and elbows as older Dynasty 19 coffin modeling that was retained and then covered over with later 21st Dynasty design. Some coffins show signs of having been changed from female type (with earrings, flat hands, and breasts) to masculine type (with a striped head-dress, fistled hands, and a beard). Other coffins show that they were scraped down of all old decoration before new plaster and paint were applied; I can only see this technique if the craft specialists left remnants of the old decoration.

Thus far, I have found only one 19th Dynasty coffin that might possibly have been reused (the inner coffin of Katebet in the British Museum⁵); it shows a change in gender, from a male wig to a female. No other signs of modification are visible on the coffin, and this could very well be a mistake in the coffin production, rectified in the decoration phase, or a reuse that occurred later in the 20th or 21st Dynasties. None of the other 19th Dynasty coffins have shown any evidence of reuse; that is, they were not made from reused 18th Dynasty or earlier 19th Dynasty coffins. Once we move to the 20th Dynasty coffins, however, the evidence immediately shifts towards an increased rate of reuse. The ensuing 21st Dynasty follows the same pattern of reuse in Egyptian coffins.

5 BM EA 6665, cf. e.g. Dawson, Gary 1968, 52 and 145.

TABLE 1 Coffin Reuse on all examples analyzed up to 2015, by country—242 Coffins Total

Rate of reuse for 20th–22nd Dynasty coffins analyzed thus far		Reuse score				TBD	Reuse %
Museum/institution	Coffins	0	1	2	3		
Berlin, Germany, Ägyptisches Museum	15	8	3	1	3	1	46.67%
Bodryddan, UK	2				2		100%
Bristol, UK, City Museum and Art Gallery	4	2			2		50.0%
Brussels, Belgium, Musée Royaux d' Art et d' Histoire	12	3	1	1	6	1	66.66%
Copenhagen, Denmark, Copenhagen Nationalmuseet	11	5	3	1	2		54.54%
Copenhagen, Denmark, Ny Carlsberg Glyptotek	1				1		100%
Cortona, Italy, Museo dell'Accademia	2					2	TBD
Edinburgh, UK, National Museums of Scotland	5	2	1		2		60%
Exeter, UK, Royal Albert Memorial Museum	1	1					0%
Florence, Italy, Museo Archeologico	17	4	2	1	10		76.46%
Houston, TX, USA, Houston Museum of Natural Science	1	1					0%
Leeds, UK, City Museum	2	2					0%
Leiden, Netherlands, Rijksmuseum van Oudheden	14	5	3	1	4	1	57.14%
Liverpool, UK, Merseyside County Museum	4		3		1		100%
London, UK, British Museum	33	15	11	1	6		54.54%
London, UK, Petrie Museum	1				1		100%
Manchester, UK, Manchester University Museum	1		1				100%
New York, NY, USA, Metropolitan Museum of Art	24	7	6		9	2	62.5%
Paris, France, Musée du Louvre	31	10	7	8	6		68.24%
Perth, Scotland, UK, National Museums of Scotland	2				2		100%
Stockholm, Sweden, Stockholm Medelhavsmuseet	4	1	1		1	1	50.0%
Swansea, UK, The Wellcome Museum	1		1				100%
Turin, Italy, Museo Egizio	20	6	4	4	5	1	65.0%
Vatican City State, Museo Gregoriano Egizio	17	9	1	1	5	1	41.17%
Vienna, Austria, Kunsthistorisches Museum	15	1	7		7		93.34%
Warrington, UK, Warrington Museum & Art Gallery	2				2		100%
Totals	242	82	55	19	77	10	65.85%
Totals for reuse with high confidence				19	77		39.67%

Thus far, I have seen about 250 coffins in person—documenting them photographically and examining them for reuse. The rate of evidence for reuse for coffins analyzed thus far in the twenty-six museums I have visited stands now at about 65% (Table 1). In other words, about 65% of the 21st to early 22nd Dynasty coffins show evidence that they were reused for another deceased individual. Even if I remove those coffins for which there is only a suspicion of reuse, the rate comes in at almost 40%. Furthermore, I suspect much of the reuse in this time period of crisis and economic scarcity is still cleverly hidden. If I could scan underneath the plaster and see older plaster layers (all but impossible with current X-Ray technology) or perform Carbon-14 dating of the wood and expose the reuse of old lumber, or do CT scans and look for remnants of reused lumber, like older mortis and tenon joins, hidden in the wood interior, I suspect that the evidence of reuse would be much higher. Technical examinations have shown “clean” coffins to have actually been made of reused coffin wood. The late 20th or early 21st Dynasty coffin of Nespawersheft in Cambridge,⁶ for instance, showed no obvious evidence of reuse to me in person, but a CT scan revealed older mortis joins hidden inside the carpentry of the inner coffin.⁷

My analysis is art historical in its foundation: careful in-person examination with a variety of light sources, usually a basic white light, but sometimes benefiting from Infra-Red Imaging (for the area where the personal name is inscribed, in particular), UV light (for examination of varnished surfaces) and, thanks to Elsbeth Geldhof’s help, digital microscopy (which can show multiple layers of painted decoration if there is a break in the surface decoration). I have also performed Carbon-14 dating on a few coffins in the dataset, one example being a *stola* coffin in a private collection, now on display in the Houston Museum of Natural Science,⁸ indicating that part of the coffin wood is 19th Dynasty in date, much older than the early 22nd Dynasty date of its decoration according to the accepted stylistic typologies.⁹ My art historical-visual analysis

6 E.1.1822, cf. e.g. Niwiński 1988, 133–134, no. 56.

7 Strudwick, Dawson 2016, 182–189, #26.

8 Maclean 1901.

9 Some of the wood used for the Houston coffin lid (4 samples) is significantly younger than 950 BCE, dating to early 22nd Dynasty, on point with the *stola* coffin decoration and indicating that Egypt was finally seeing new wood cultivation after the years of scarcity during the 21st Dynasty. The coffin case, however, shows dates that are about 300 years older than those of the lid (from two different samples). Either the coffin case was made of wood from the centre (i.e. the oldest part) of a very large tree that was felled more than 300 years earlier, or it is recycled wood. The latter explanation is the likeliest, given that this wood was likely native. Thanks to John Southon of University of California at Irvine who conducted the carbon dating.

of this Houston coffin revealed no evidence of reuse, but the technical examination proved the use of older wood, thus providing a circumstantial marker in favor of the practice of coffin reuse. The wood was many hundreds of years older than the late 21st Dynasty style, too great a difference to be explained away by ancient oversized trees, and its use may be a sign of coffin, or at least timber, reuse. Both the Houston and Florence coffins seem made of non-imported woods, probably acacia and sycamore fig, respectively, and were probably made of timber cut from much smaller trees than a centuries-old cedar from the Lebanon. In other words, I suspect that if Carbon-14 could be applied to the entire dataset, then the rate of timber, and probably also coffin, reuse from mid-20th Dynasty to early 22nd Dynasty would again be much higher than 65%.

The Florence coffins under examination below come from Bab el-Gasus and provide an excellent opportunity to view one coffin group's patterns compared to the larger dataset. The Florence Bab el-Gasus coffins actually show 100% reuse, an astounding number that provides clues into how much coffin reuse was actually happening in Thebes during the early Third Intermediate Period. The larger Bab el-Gasus reuse percentage is 85%, and I suspect it has only *not* reached 90% or higher simply because of poor access to many coffins, hampered by their location in museum vitrines, thus limiting my close up examination.

1 Methodology

In Table 1 above, I have graded my own confidence in the evidence for coffin reuse from 0 to 3, 0 being the number assigned to coffins with no evidence of reuse, 1 the number assigned when only circumstantial evidence can be found, 2 the assigned number when there is stronger evidence, and 3 when there is obvious and conclusive proof of reuse on a given coffin. As my research has developed, I have also included a 0.5 when there is just a bare suspicion of reuse, when the evidence is not strong enough for even a score of 1. The number on the bottom right shows that approximately 65% of the coffins examined thus far show reuse, a much higher proportion than I envisioned when I set out to find the lost Ramesside coffins seven years ago.¹⁰

In June 2011 and then again in June of 2015, I examined all yellow coffins currently in the Egyptian Museum of Florence, in order to elucidate different methods of reuse. I excluded most fragments, preferring to look at com-

¹⁰ I worked with the 21st Dynasty coffins in the Royal Cache from Deir el Bahari (tomb DB320) in December of 2016 and there the reuse rate was 100%.

plete pieces. Of the 18 coffins I examined in Florence, 8 come from the Bab el-Gasus. All of these Florence Bab el-Gasus coffins show evidence of reuse, but of those, only 6 of them showed strong evidence. In all, about 80% of the available coffins in the Egyptian Museum of Florence showed reuse, which is much higher than the overall rate of 65% and nearly as high as the Bab el-Gasus rate of reuse of 84%. I think it is the high preponderance of Bab el-Gasus coffins which raised the overall rate of reuse of 21st – early 22nd Dynasty coffins in Florence.

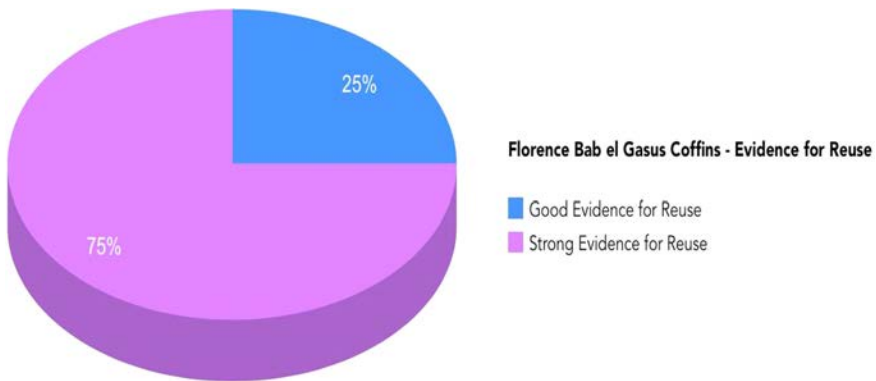

FIGURE 291 Evidence for reuse in the Italian Lot

I am grateful for my up close access to these coffins in storage in Florence, which allowed me to document and prove such a high rate of reuse. Indeed, I suspect that most, if not all (!) Bab el-Gasus coffins will show some evidence of reuse if the appropriate access for study is gained and the appropriate technology applied.

The reasons for this high rate of reuse are many. First, we are dealing with a time period of economic scarcity, and while pigment and varnish seems to have been available to Theban elites, wood was a limited commodity. It is highly likely that the only way to procure a transformative coffin for one's loved one was by reusing a coffin (or coffin wood) from the family tomb, or by buying a reused coffin at a craft installation of some kind. Second, many of the Florence coffins find their origin in the Bab el-Gasus cache, and these pieces also show higher evidence of reuse than the 21st Dynasty coffin assemblage as a whole. This Bab el-Gasus group of Theban Amun priests participated in decorative reuse—updating styles of older coffins, gender reuse—changing the gender of a coffin from male to female or vice versa, name reuse—changing the name and sometimes also the title to match the new owner, often keeping the rest of the decoration the same.

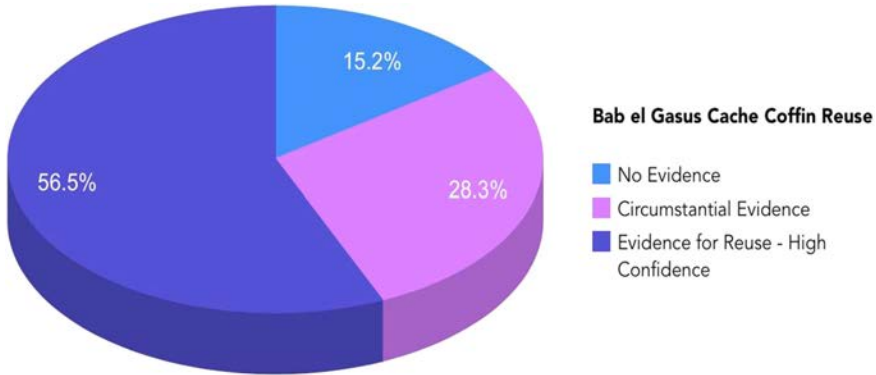

FIGURE 292 Coffin reuse in Bab el-Gasus

Sometimes there are structural markers of older Ramesside coffins, like the body undulations of a 19th Dynasty coffin of the deceased female in daily dress, or of the masculine plaster relief tripartite tiered wig, which have been painted over with 21st Dynasty Solar-Osirian decoration. The amount of reuse as gender modification is so pervasive amongst the Bab el-Gasus cache owners that I would argue for the reuse happening largely in the context of the family, as a legal and opportunistic practice in which the family burial chamber was used for the raw material of the next family member, male or female. If one were buying a masculine coffin on the open black market, from stolen coffins, there would not be so much gender modification visible in the Bab el-Gasus cache. Changes in coffin gender are a testament to the family's struggle to bury their dead using, it seems, one coffin set that had to be changed as necessity demanded. The pervasive Bab el-Gasus coffin reuse also suggests the priority of short term ritual use over long term coffin ownership. This, it seems, was the agenda for most Egyptians burying their dead in this time of material scarcity. The amount of varnished blank spaces for names even suggests that a kind of short term coffin use or rental was practiced (although direct proof in the form of receipts for such rental has never been found).

Long story short: when faced with scarcity, the only moral solution for the ancient Egyptians was to take their ancestors out of their coffins, bringing these coffins to a craft workshop for redecoration, ideally updating the coffin style and adding the name and title of the new deceased individual to be contained in the object. The Theban priests in the Bab el-Gasus cache were no exception to this rule. Indeed, they seem to have been veritable masters of the art of coffin reuse.

Identifying coffin reuse is a challenging business and includes finding pigments under plaster layers and varnish under paint layers, or by observing

inconsistency between a coffin's poor quality decoration and the fine quality wood from which it was built. This article will, I hope, elucidate what evidence for reuse can look like—from the most obvious examples to the most circumstantial, giving other researchers a chance to correct and supplement my work, which I must point out is a moving target and research in progress. My tables and graphs are always changing as I improve my research techniques, gain better access to a particular museum's coffins, or add more samples to my data set. Despite my subjective eye, some evidence of reuse is beyond doubt. It is my hope that this research will provide a better idea of how the Egyptians covered their tracks when they were reusing a coffin and what they felt was absolutely necessary to change when using the coffin again for a new occupant.

By the same token, I must reiterate that our current 21st Dynasty coffin typology¹¹ is needlessly complicated, precisely *because* of reuse—because craftsmen often took shortcuts, keeping older decorative or structural elements, blending them into new elements, only updating what was really necessary. Thus, a given coffin might have a 19th Dynasty wig style but a mid-21st Dynasty collar and pectoral, or 19th Dynasty modeled feet and 21st Dynasty yellow background decoration. The practice of coffin reuse results in a *mélange* of styles, making typological seriation a complicated endeavor.

Even though he was the first to suggest that most Ramesside coffins were reused in the ensuing dynasties, Niwiński rarely saw reuse clearly in the coffin record. Ironically, instead of identifying the reuse visible on a given coffin, Niwiński often concluded that what he was seeing represented archaism instead and that the Egyptians were referring back to earlier fashions.¹² Perhaps it is because I wrote my first book *The Cost of Death* on 19th and 20th Dynasty coffins that I am often able to see older decoration styles and modeling, even

11 This typology is based on Niwiński 1988. For more discussion of Dynasty 21 coffin typologies, see Van Walsem, 1993; Cooney 2014.

12 For example, the inner coffin of Tamutmutef (Turin 2228, CG 10119a–b, 10120) has a lid with the female deceased holding one arm bent against her chest and the other flat on her thigh, while the contours of her body are carved out of the surface wood. Niwiński (1988, 172) dated this coffin to the late 21st Dynasty in his catalogue, while I see the coffin as a reused 19th Dynasty female coffin type that once showed the deceased female in daily dress, with arms holding ivy or convulvulus leaves, repainted with a yellow Osirian decoration typical of the 21st Dynasty (see Cooney 2011, 34–36). Indeed, Niwiński (1988, 79–80) creates a new type (Type IV-c) for female owners of this type of coffin, seeing it as archaizing. I feel it is safer to see this not as an archaizing type, but as an opportunistic reuse of an older style when craftsmen are taking shortcuts and not redoing a coffin completely. In addition, we can and should date the construction of a given coffin separately from its decoration.

in fragmentary form, as just that—evidence of older coffins underneath later reuse actions. For example, if a 21st Dynasty coffin has a wig that was out of fashion by that point in time and more in line with a 19th Dynasty type coffin, then I am more liable to conclude that this coffin was reused and that the craftsman retained the older wig.

The data for reuse will be analyzed according to set. If a coffin and mummy-cover were found together, they are analyzed here together as a set, with the knowledge that some coffins may have been put together by dealers, rather than by the ancient funerary specialists.

2 Coffin Data from the Egyptian Museum of Florence

2.1 *The Outer Coffin (Florence 8523) of Ankhefenkhonsu, from A.60—Reuse: 3*

I did not identify a complete coffin set for this individual as Niwiński has in his catalogue (outer coffin, inner coffin, mummy-cover). The accession number of 8523 only applies to one outer coffin, as far as I can tell. The coffin seems made of local wood, likely acacia or sycamore, but no testing was done to determine species.

The coffin was certainly reused. There is evidence of decorative reuse and name reuse, suggesting a multiple reuse. The name Ankhefenkhonsu is written in red paint only, despite the surrounding polychrome inscription, a clear indication that the name was added at a later time (Fig. 157). The name is found on the coffin case's left side at the foot end. It is also clear that craftsmen erased a previous inscription to add the name Ankhefenkhonsu. There are traces of a red line underneath the *ankh*-sign in the name, and there is evidence of an old Egyptian blue inscription in the infrared photographic examination. It is likely that there was polychrome text here before the name was inscribed in red—probably the name of the previous owner rubbed away in a reuse action.

The coffin was reused and reinscribed for Ankhefenkhonsu, and there may have been another one or two even older reuses, betrayed by 1) older polychromy underneath the current striped blue and white headdress at back of head on the lid and 2) older modeling at the forearms indicative of a 20th or early 21st Dynasty coffin, instead of the late 21st Dynasty coffin we see in the surface decoration. There are clearly two plastered polychrome layers visible. The later plaster layer is a thick mud plaster, and the earlier layer is a thin white layer. The thick mud plaster is visible on the case as well, suggesting that the decorative modifications of the coffin case go with the headcloth modifications as well.

The plaster at the head end of the lid shows an older plaster surface with red and yellow colours (paint and possibly varnish). There is definitely another polychrome layer underneath the striped blue and yellow headcloth (Fig. 293). Indeed, the orpiment of the headcloth has a very different florescence when compared to the orpiment of the *usekh*-collar, suggesting different times of execution, different workshops, and different pigment mixtures for the headcloth and *usekh*. Maybe the mud plaster of the case matches the mud plaster of the wig. The *usekh*-collar was applied onto a fine white plaster with huntite, which was applied over a thick mud plaster layer. Microscopic examination by Elsbeth Geldhof shows that the headcloth was painted over the *usekh*-collar, suggesting that the headcloth was changed for a later user while retaining the older collar. We were unable to ascertain definitively if the headcloth was painted over the varnish of the colour, but it seems likely.

Interestingly, there is a spot of damage on the wood on the lid at the back of the head, and decoration (stripes of the headcloth) was applied into the concavity, suggesting reuse of a piece that was roughly stripped down or damaged in transport. Overall, the plaster applied to the surface of the coffin is very thick, as one often sees on coffins with decorative reuse. The face is built up almost entirely of plaster, a modification ostensibly allowing the reuse of the coffin lid.

The coffin lid betrays earlier coffin modeling because it shows forearms and shoulders carved from the wooden surface, a feature of earlier coffins, but not later 21st Dynasty examples (Figs. 144–303). The fisted hands show holes, to hold sacred emblems, a feature more associated with earlier coffins as well (Fig. 145). The *usekh*-collar is quite long (20 cm under the fisted hands) and indicative of a later 21st Dynasty date for this decorative layer, going about 20 cm under the fists (Fig. 303). Given the modeled arms and given that the collar is the oldest known decorative layer on this coffin, it is likely that there was at least another older decorative layer before what is visible now. I would suggest that this coffin was constructed in the 20th Dynasty or early 21st Dynasty to be reused with new decoration in the late 21st Dynasty.

Furthermore, the lid ledges are flat and unfinished, while the case has a stepped ledge. This is clearly indicative of reuse, suggesting that lid and coffin were not made for one another originally and that the case is likely older than the wood in its construction.

There is a beard hole visible underneath the chin, fitting with the masculine fisted hands.

2.2 *The Outer Coffin (Florence 8524) of an Anonymous Woman from A.15—Reuse: 3*

This outer coffin shows multiple reuse in the form of decorative reuse, gender modification, and a blank space for the owner's name.

The lid shows the gender modification from a masculine coffin to a female coffin quite clearly: Earrings and breasts were added in plaster (Fig. 13). The hands seem to have been changed as well, from masculine fistled hands to female flat hands. The beard hole was covered by plaster, now currently a raised area with the diameter of a peg hole underneath the chin. The area for the name on the lid's feet is blank and varnished over, creating a possible "parish coffin" that could be reused multiple times for short-term owners who had their name inscribed over the varnish, to be easily wiped away after the funeral proceedings with a damp cloth (Fig. 17). The title and inscription were changed to match a female coffin (*Wsr m:t hrw dd.s h: mwt Nwt ...*).

The case sides were modified as well to show a woman in the two-dimensional offering scenes. She is wearing the same blue dress throughout, and no name of the deceased owner is visible (Fig. 294). The modifications for the gender change are also visible at the neck area where the *usekh*-collar was repainted. The application of paint is messier here, but the artisan tried to match the floral decoration of the existing collar. When the artisan changed the headdress and earrings and collar, he smoothed plaster over the surface of the hair and collar and thinly scraped it to the outer edges of the collar. Some of this plaster has cracked, and the decoration underneath is visible. The artisan tried to match the older floral decoration at the sides of the lid, so that he did not have to redo the entire surface. It is interesting the craftsmen would try to save and match older decoration, if possible, taking the time to match the old surface, instead of redecorating the whole thing. This technique is easiest to see on the lid's right side, where the new plaster of the headdress was applied to cover the old *usekh*-collar.

The coffin was used at least once before the gender modification. At the back of head on the lid's left side is painted plaster of an older striped headdress about 1 cm underneath the present painted plaster. These are likely the blue and white stripes of an earlier 21st Dynasty coffin, probably a man's coffin.

2.3 *The Anonymous Outer Coffin (Florence 8525) from A.56—Reuse: 3*

This outer coffin lid shows decorative reuse (gender modification) and blank spaces for the name of the owner in multiple locations, including lid and lid side inscriptions; the title *wꜥb n imn sš n ____* is visible on the coffin feet and side inscriptions (Fig. 295). Niwiński mistakenly says this coffin is for an anonymous Chantress of Amun in his catalogue. The fact that the blanks were all

varnished over suggests it could have been meant to serve as a communal coffin for the Theban priesthood. We were unable to do any infrared photography of these blanks because the coffin needed to remain on the museum storage shelf for conservation reasons.

The coffin lid's gender modification was from a woman to a man. This is clearly visible at the back of the head where blue stripes of a masculine headdress were painted over and around the pre-existing female head garland. Elisabeth Geldhof established this with microscopic photography. Why they kept the head garland on a masculine coffin is not clear, but it was integrated with the striped headdress. There is no other evidence of a pre-existing female headdress except for the head garland, and we should suppose that it was chiseled away in preparation for the new masculine owner.

Masculine ears were added in plaster (a female coffin would have covered the ears with a blue headcloth), and a beard strap was added in blue over the varnish of the face. There are no remnants of breasts, suggesting that they removed them when they changed the hands. The decorative surface of the chest was completely updated for the man's coffin, it seems.

Interestingly, the wig lappets betray a high curve in sections as would be seen on a 19th Dynasty coffin. No Carbon-14 dating was performed, but it would be the ideal way to test the theory that this 21st Dynasty coffin was originally a 19th Dynasty coffin.

2.4 *The Anonymous Inner Coffin (Florence 8526) from A.60—Reuse: 3*

This inner coffin is clearly reused. First, the lid and case do not fit; the lid is too wide on the coffin's left side. The outline of the head does not fit, especially on the left side; there is also a huge gap near the feet, with a 4 cm overlap here, too much for even the worst of wood warping (Fig. 296). It is likely that the lid and case belonged to two separate coffins originally and that they were brought together opportunistically during a previous reuse. Second, there are markers of a Ramesside coffin. The case may be 19th or 20th Dynasty in its original construction and decoration as it shows an earlier style of decoration and betrays at least two hieroglyphic hands (ostensibly the second added during a reuse event). Third, there are remnants of a gender modification. The coffin lid shows a female, but the coffin has added earrings and breasts, and a modified wig. Third, there is evidence of name reuse. This is probably a triple reuse, at the least. The *wb n imn* title mentioned by Nawiński in his catalogue was not visible to me during my examination.

The coffin case is almost certainly Ramesside in style with a figure of Thoth at the head end. The interior of the case has a dark red background and a large figure of a goddess of the West, another marker of an earlier 21st Dynasty cof-

fin. The case shows an inscription for a *nbt pr šmꜣyt n imn ꜥḥ-pw(?)*. The lid likely belonged to another, older coffin, and there are remnants of older style of decoration on the lid below the lappets: a Nut figure and a winged khepri that have been retained and around which new, updated decoration was added.

2.5 *The Inner Coffin (Florence 8527) and Mummy-Cover (Florence 9530) of Khonsumes from A.22—Reuse: 3*

This coffin set shows reuse as a set and as individual pieces, including decorative reuse, name reuse, gender modification, and markers of the Ramesside Period. The coffin set was decorated for a man, but quickly redecorated for a woman by just adding earrings and changing the hands, but not redecorating the striped masculine headdress. The hands on the coffin have been lost, but the modification is still visible in the painted plaster substrate where they have fallen away because the outlines of the decoration match fistful male hands rather than flat female hands (Fig. 297). The oblique angle of the added flat female hands was similar on both inner coffin and mummy-cover. The wings of a heart scarab are positioned under the hand addition. Indeed, it seems that the added female hands were placed at an oblique angle to keep as much of the original decoration as possible.

Interestingly, the artisans retained the striped masculine headdress, believing added earrings and flat hands to be enough for the modification. No changes were made to the carving or paint of the face plate. No breasts were ever added to coffin or mummy-cover. The coffin also retains the masculine name and title, despite the gender modification to female, on the lid's side inscriptions. The title and name of the masculine owner is preserved on the coffin lid's left side, along a text column near the feet: *sš n pr imn nswt ntrw ḥnsw(-ms)*. Although the coffin was redecorated for a woman, I can't identify her name having been added anywhere. The two-dimensional depictions of the male deceased were also not changed on the lid or case sides.

The modeled arms on the coffin suggest a Ramesside or early 21st Dynasty construction for the inner coffin, suggesting at least two reuses of this coffin. The wood is probably local, joined together from small pieces of what is likely acacia or sycamore fig.

The mummy-cover shows that a new feminine title of *nbt pr* was added in a different, lower quality, hand. This is the only place that a new title was added to the entire set, suggesting perhaps that there was more funerary ritual focus on the mummy-cover at this time period. The flat hands were attached obliquely by the reusing artisans (Fig. 298), a similar feature to the inner coffin (although the hands have fallen away from the inner coffin). Earrings are painted over the striped headcloth of the mummy-cover, just like the coffin. It seems clear that

the coffin and mummy-cover were decorated to match one another, ostensibly for a man named Khonsumes, and that they were then reused together for a woman and bear similar features of that reuse, including oblique hand placement to save decoration on the chest.

2.6 *The Inner Coffin (Florence 8528) and Mummy-Cover (Florence 9534) from A.15—Reuse: 2*

This inner coffin and mummy-cover are almost certainly reused, showing probable decorative reuse in the form of gender modification, plus blank spaces for a name with a generic female title (Fig. 299). The inner coffin also shows a beard hole despite the fact that it is a woman's coffin. The checkered wig and earrings were possibly added later. The lower legs may have been updated, but this needs further examination. Indeed, the coffin lid betrays two levels of quality in the draftsmanship: the long collar is carefully and expertly applied, but the lower body's painted decoration is crudely applied. It seems certain that the collar and the lower legs were painted by two different craftsmen, perhaps at two different times in the coffin's use. The legs of the coffin lid have a very thick layer of plaster, perhaps modifying older and outdated coffin modeling, again an uncorroborated detail.

The title of the coffin owner is inscribed as *nbt pr smꜣyt n imn nswt ntrw* _____, with a blank for the name. The title and blank appear in many places. This varnished blank would have provided the perfect surface for a coffin reused time and time again.

The mummy-cover with accession number 9534 is not in Niwiński's catalogue, but it belongs to the same coffin as 8528. It betrays the same differing quality levels of draftsmanship between collar (high quality) and lower legs (low quality). The same high plaster relief seems to have been added to the lower part of the mummy-cover, but like the coffin lid, it has not been substantiated that this lower leg decoration was changed in a reuse event. It is also possible, though not definitive, that a beard hole was covered over with plaster, as on the inner coffin. Like the inner coffin, the mummy-cover may have the addition of a new wig, breasts, and earrings.

Both coffin and mummy-cover seem to have a modern varnish, resulting in a very shiny surface, but this has not been corroborated in material science studies. The *usekh*-collar is really nicely done with detailed, fine painting work, but the lower part of the lid seems coarse and with lots of plaster. I suspect they plastered over the lower part of the coffin and repainted it. There is a great deal of high plaster relief on the lower lid, but not carefully done.

3 Conclusion

In conclusion, the close examination of a group of coffins for evidence of reuse is both hyper-detailed and broadly anthropological. The catalogue of evidence is necessary for other researchers to check my work and, if that is even possible, see through my eyes. Detailed conservation information is necessary so that Egyptologists know what analysis has technical examination behind it, and what is supported by visual examination alone. Once all the evidence is described and analyzed, however, we are left with a percentage of coffin reuse that is on point with the 21st Dynasty coffin dataset as a whole—almost 60%—and if we could examine these coffins with more technical methods, the percentage would certainly be higher. And then we are left with the surprise that there is so much evidence for a human behavior that the Egyptians themselves never talked about in a positive way and obviously tried to cover and veil. This high percentage of reuse speaks to the time of crisis and material scarcity, yes, but it also speaks to a communal agreement that coffin reuse was the best possible way to deal with this practical problem.

In the ancient textual record, tomb robbery and funerary arts reuse were discussed either in a punitive context (as in the Tomb Robbery Papyri¹³) when people are being interrogated and tried, or it was purposefully veiled (like in the Late Ramesside Letters or the Deir el Medina inventory texts).¹⁴ But the fact that 100% of the Florence Bab el-Gasus coffins were reused suggests that just about everyone in ancient Thebes who could afford a coffin was engaging in this practice to transform and protect their dead relatives. We just have no direct written evidence of it. But why would anyone have written down that they took a family ancestor out of her coffin, moved her mummy to a corner of the tomb, took the coffin out of the tomb, redecorated it with appropriate and fashionable decoration, and used it for another relative? This was unseemly behavior, best kept disguised.

For most of its history, Egyptology has looked upon tomb robbery and funerary arts reuse as aberrant, regressive, and abnormal. Documents like the Tomb Robbery Papyri have reinforced that mindset. In their literature, the Egyptians themselves repeatedly describe the ideal (read: “normal”) burial situation as a stone house in which the ancestors reside for eternity, supported by income-producing lands set aside in an endowment to pay for priests and provisions in perpetuity. However, in the last two decades, many Egyptologists have looked to

13 Peet 1930.

14 For discussion thereof, see *ibid.* and Cooney 2015, 79–90.

the entire 'life cycle' of a tomb, pointing out that tomb robbery and reuse were not only a part of necropolis life, but that tomb robbery had been practiced since the beginnings of ancient Egyptian complex society, a reality of which the Egyptians themselves were well aware.¹⁵

The rate of reuse on these Florence coffins allows us to understand that the ancient Egyptians saw funerary transformation as their priority. Once the dead had benefited from the coffin materiality in ritual, both public and private, the coffin did not absolutely have to remain with the dead. This longer term agenda—perpetual ownership by the dead—was usually prohibitively expensive and only possible during times of plenty. Inevitably, times of crisis, like the 21st Dynasty—hit any civilization, and it is during these lean years that accumulated materiality could be recommodified and reused.

15 Baines, Lacovara 2002. Näser 2008.

TABLE 2 Coffin Reuse in Bab el-Gasus: coffins from the Museo Archeologico, Florence, Italy

Accession no.	Coffin type	Coffin part	Dating	Provenance	Name(s) of deceased	Title	Reuse score	Type of reuse
8523 (among others)	Outer coffin	Case + Lid	Mid to late 21st Dynasty	From the tomb of Bab el-Gasus, found in Deir el-Bahari in 1891, presented by the Egyptian Government in 1893	Ankhefenkhonsu; Niwinski has Ankhesemut the usurper		3	Decorative reuse, name reuse
8524 (among others)	Outer coffin	Case + Lid	Mid 21st Dynasty	From the tomb of Bab el-Gasus, found in Deir el-Bahari in 1891, presented by the Egyptian Government in 1893	Anonymous	Chantress of Amun	3	Multiple reuse, decorative reuse, gender modification, blank space for name
8525	Outer coffin	Lid	Late 21st Dynasty	From the tomb of Bab el-Gasus, found in Deir el-Bahari in 1891, presented by the Egyptian Government in 1893	Anonymous	Chantress of Amun	3	Blank space for name
8526 (probably)	Inner coffin	Case + Lid	Early to mid 21st Dynasty	From the tomb of Bab el-Gasus, found in Deir el-Bahari in 1891, presented by the Egyptian Government in 1893	Kar (according to Niwinski)	Priest of Amun	3	Multiple reuse, decorative reuse, name reuse, gender modification, markers of Ramesside coffin

TABLE 2 Coffin Reuse in Bab el-Gasus: coffins from the Museo Archeologico, Florence, Italy (*cont.*)

Accession no.	Coffin type	Coffin part	Dating	Provenance	Name(s) of deceased	Title	Reuse score	Type of reuse
8527	Coffin	Case + Lid	Early to mid 21st Dynasty	From the tomb of Bab el-Gasus, found in Deir el-Bahari in 1891, presented by the Egyptian Government in 1893	Khonsumes (I don't see a re-inscribed name, but Niwinski notes the usurper's name is this.)		3	Decorative reuse, name reuse, gender modification, markers of Ramesside coffin
8528	Inner coffin		Mid 21st Dynasty	From the tomb of Bab el-Gasus, found in Deir el-Bahari in 1891, presented by the Egyptian Government in 1893	Blank Name	Mistress of the House, Chantress of Amun	2	Blank name with generic title, decorative reuse, gender modification, blank space for name
9530	Mummy board (belonging to 8527)		Early 21st Dynasty	Bab el-Gasus	Khonsumes (I don't see a re-inscribed name, but Niwinski notes the usurper's name is this.)		3	Decorative reuse, name reuse, gender modification
9574	Mummy-board		Mid 21st Dynasty	Bab el-Gasus			2	Gender modification



FIGURE 293 (Inv. 8523) The plaster applied to the surface of this coffin is very thick, as is common on coffins with decorative reuse.



FIGURE 294 (Inv. 8524) The case sides of this coffin were modified to show a woman in the two-dimensional offering scenes, evidence of gender modification for reuse by a woman.



FIGURE 295 (Inv. 8525) The title *wꜣb n imn* _____ is visible on this coffin's feet and side inscriptions. The fact that the blank spaces for a name were all varnished over suggests it could have been meant to serve as a communal coffin for the Theban priesthood.



FIGURE 296 (Inv. 8526) The lid and case of this coffin do not fit; the lid is too wide on the coffin's left side. The mismatched lid and case likely indicate reuse.



FIGURE 297 (Inv. 8527) The modeled arms on the coffin suggest a Ramesside or early 21st Dynasty construction for the inner coffin, suggesting at least two reuses of this coffin.



FIGURE 298 (Inv. 9530) The flat hands on this mummy-cover were attached obliquely by the reusing artisans, a similar feature to the inner coffin (although the hands have fallen away from the inner coffin).

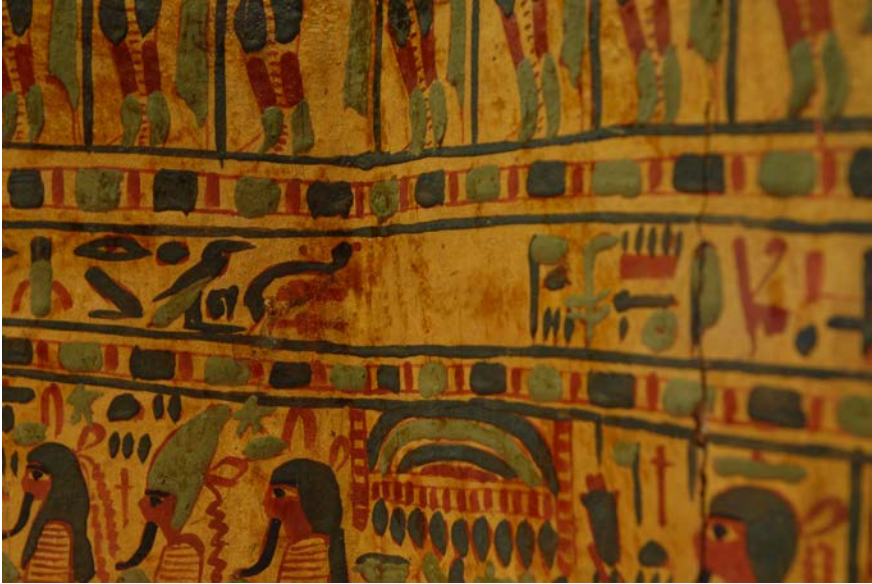

FIGURE 299 (Inv. 8528) The title of the coffin owner is inscribed as *nbt pr smyt n imn nswt ntrw _____*, with a blank for the name. The title and blank appear in many places. This varnished blank would have provided the perfect surface for a coffin reused time and time again.

The Coffins of the Tomb of the Priests from an Art Historical Perspective: Lot v at the Egyptian Museum of Florence

Rogério Sousa

During the 21st Dynasty, coffins played a bold role in the Theban society. Despite the economic and socio-political crisis, the corpus of anthropoid coffins crafted during this period outnumbered the previous types of body containers. Moreover, the so-called ‘yellow’ coffins bear witness to an astonishing rise in complexity in terms of their decoration. A significant part of this documental corpus originates from a single archaeological site, the collective Tomb of the Priests of Amun, at Deir el-Bahari, in Thebes. In this undisturbed tomb, more than 250 coffins and mummy-covers were uncovered in 1891, forming the widest sample of coffins originating from the same burial ground.¹

In this study, we examine the coffin sets that were shipped to Italy (Lot v) in 1893 from an art historical perspective in order to identify the peculiar organization of each object in terms of layout, style, and design. We will use in this examination the typological approach we developed,² which is consistent with the topography used in the ‘Catalogue’ to describe the coffins.³

1 The Burial Assemblages of Lot v

The five burial assemblages examined in this book were found in the first sector of the main gallery (see the tomb plan—Fig. 6). Three of them (A.15, A.20 and A.22) were found not far from the entrance and were used as part of the defense system of the tomb, blocking the way to its inner areas. A.15, and A.20, in particular, were grouped together with other coffin sets, forming the second and the third barrier of coffins. The coffin sets A.56 and A.60 were found after these sets of barriers. Here, the crowded assemblage of burials gave place to a very organized arrangement, with the coffin sets carefully positioned against the walls. Both these coffin sets were positioned against the western wall.

1 Sousa 2018a.

2 Sousa 2017b.

3 This topography is based on the concept of ‘architectonisation’ proposed by René Van Walsem. See Van Walsem 1997.

From the artistic point of view, the sample of coffins gathered in Lot v is extremely heterogeneous both in terms of quality and in terms of dating. Since in the ‘yellow’ corpus, the lids and the cases were decorated independently from each other, we examined separately the layout of these objects. Given the high rates of reuse identified by Kathlyn Cooney, it is also a good practice not assuming from the start that the lid and the case from a particular burial set were crafted together. This precaution is even more important when we deal with coffins from the Foreign Lots of the Tomb of the Priests, as during the preparation for shipment, a number of mistakes occurred and objects from different coffin sets became wrongly assembled in the same group. In these circumstances, when examining a particular coffin set one has to consider if it is indeed an ancient assemblage or a modern one.

The results obtained in this way will be used to understand how each burial assemblage was formed, contributing to reveal the dynamics of use of the funerary goods during the 21st Dynasty.

1.1 *Lids and Mummy-Covers*

A.20 The Lid and Mummy-Cover

The layout of these objects offers a glimpse on the earliest design of ‘yellow’ coffins found in the objects from the Lot v, the so-called ‘basic scheme’ (Figs. 68/85).⁴ This is indicated by a wide sample of features. The forearms display a variety of bracelets and the floral collar is equipped with falcon-headed terminals.⁵ The central panel is designed according to the basic scheme, displaying two registers.⁶ The lower section displays two lateral partitions flanking a longitudinal band of text, another key-feature pointing to an early dating.⁷ However, the lateral partitions of the lower section already show a sequence of deities (Osiris and avian form of Ptah-Sokar) typically found slightly before the mid-21st Dynasty.

The carpentry work involved in the craftsmanship of the object is mediocre with the anatomical volumes poorly shaped. The pictorial work is slightly better. The style of the decoration is naturalistic,⁸ but the composition is highly informal. Despite that, the pictorial tableaux are well executed, and the iconographic repertoire of each scene is faithfully reproduced in its most essential

4 Sousa 2018b, 201–202.

5 See typology of the upper section, in Sousa 2018b, 172, 277.

6 See typology of the central panel, in Sousa 2018b, 173, 277. For symbolism of this layout see Sousa 2018b, 201.

7 See typology of the lower section, in Sousa 2018b, 173/278.

8 Regarding the style in coffin decoration see Sousa 2018b, 175.

features. The central panel is a good example of this, displaying all the expected key-features.⁹ The craftsmen working in this object were focused in observing the most basic conventions but clearly avoided any risk by introducing variations.

When compared with the lid, the mummy-cover from A.20 displays subtle differences. The central panel follows the same layout observed on the lid but it lacks the centripetal blocks. Moreover, the centrifugal god is now the avian form of Sokaris and not Osiris. Differences like these are often detected, with mummy-covers normally displaying a simpler layout.¹⁰ Perhaps more meaningful is the fact that it does not display breasts, suggesting, as Kathlyn Cooney points out, that it might have been recycled from an object previously crafted for a man. Despite that, the level of craftsmanship is equivalent to the lid, not to speak of the close resemblance of the inscriptions.

The decoration of the lower section provides the most striking contrast with the lid, as it is entirely decorated with a beaded pattern outlined in white against a reddish background. Although not exactly exceptional,¹¹ this irregular layout represents a clear break with the most basic conventions ruling the lower section. Instead of the usual partitions decorated with deities, the object depicts the mummy, thus creating a 'transparency' effect that blurs the materiality of the object and gives 'full' visibility to the hidden mummy.¹²

Despite the crudeness of the craftsmanship involved in the decoration of both objects, it is clear that they were carefully designed in order to observe the 'official' guidelines that made these objects 'effective' from the magical and ritual point of view.

A.22 Lid and Mummy-Cover

The lid and mummy-cover of the burial A.22 were clearly produced together to form a burial assemblage of fine quality (Figs. 94/111). On both objects, the upper section and the central panel feature the layout of the 'basic scheme', typical of the first half of 21st Dynasty: the floral collar is relatively short (6 bands) and it is equipped with falcon-headed terminals, the forearms are visible, the central panel displays two registers.

9 Sousa 2018b, 99–105.

10 See, for example, mummy-cover from A.22 and compare with the lid from the same coffin set.

11 See mummy-cover of Tjenetpenherunefer (A.47), in Mann, Greco, Weiss 2018, 45. See mummy-cover of Ankhefenmut (A.68). Lacovara, Haynes 2018, 69 (fig. 49).

12 Regarding the meaning of 'transparency' in coffin decoration see Liptay 2017, 269. See also Sousa 2018b, 198.

And yet, the level of complexity of the compositions is already increasing. On the lid, the central panel makes use of additional blocks on the edges of the tableau, attesting the beginning of a trend that eventually originated the miniaturist and highly detailed compositions which became typical during the second half of the 21st Dynasty.¹³ The density of depiction increased but this effect is achieved by using inscription-labels. Liminal elements are conspicuously absent.¹⁴

The lower section of the lid is designed after the 'classical' scheme introduced shortly before the mid-21st Dynasty.¹⁵ This area is now designed as a triptych, featuring a typical sequence of deities involving Osirian gods and the avian form of Ptah-Sokar (lateral partitions)¹⁶ and sacred totems (central partition).

On the footboard of the lid, innovative features are detected, such as the depiction of Osiris, standing before the mourning goddesses, a motif that also became typical from the mid-21st Dynasty onwards.¹⁷

The style is fairly naturalistic but we already sense the schematic design which will become prevalent during the second half of the 21st Dynasty. Despite that the quality of the pictorial work is excellent.

The headboard and the upper section reveal traces of secondary interventions aiming at the recycling of the object.¹⁸ These interventions mainly consisted in the addition of female attributes.¹⁹ Otherwise the object reveals typical male features, such as the striped wig with terminals and geometric headband. Moreover, on the pictorial tableaux of the lid and the case, the deceased is always depicted as a male: in the central panel he is featured as a male *ba*-bird and in the lower section he figures as a justified god, clad in white festive garments.

The quality of the object is excellent in terms of craftsmanship. The face is beautifully carved. The pictorial work observes the sculptural rendering of the face and the anatomical details are outlined in red, such as the eye-lid, the lips, and a double horizontal line depicting creases on the throat. Red paint was added to decorate the nostrils and the corners of the lips, creating interesting shadowy effects. Note that the ears have been removed.

13 See central panel from A.15 (outer coffin), A.60 and A.65 (outer coffin).

14 Regarding these features see Sousa 2018b, 108.

15 See Sousa 2018b, 138.

16 See Sousa 2018b, 135.

17 See Sousa 2018b, 159.

18 See the study by Kathlyn Cooney in this volume.

19 Earrings were painted over the original striped decoration of the wig, the ears were removed and the area was restored with new painting, the fists were removed, as well as the divine beard. See in this volume the text by Cooney.

Inscriptions are interestingly used to border the edges of the lid. The name of the original owner was erased on the right side (Inscription 1), but it was kept on the left side (Inscription 2).

The mummy-cover also reveals traces of secondary interventions aiming at the recycling of the object: earrings were painted over the original decoration, the ears were removed and the area was restored with new painting, the hands (originally fists) are open (a female attribute).

The layout of the mummy-cover follows the scheme of decoration observed on the lid: the floral patterns used in the decoration of the large collar are very similar to those used to decorate the lid, as well as the central marker of the upper section, which is the same. The decoration of the forearms is also very similar. The composition of the central panel was adapted, clearly displaying a simpler version of the panel depicted on the lid (additional blocks were avoided). On the lower section, the central partition was not included either and a double band of inscriptions was added instead. The result is an object formally rooted in the scheme of decoration of the lid but displaying a rather conservative layout, as many of the innovative features displayed on the lid were not included on the mummy-cover.

A.60 Inner Lid and Mummy-Cover

The inner lid found in the burial A.60 is clearly a transition work towards the 'classical scheme', the design typically found in the mid-21st Dynasty (Fig. 169). The scheme of decoration still includes the depiction of the forearms, but the lower section already displays three longitudinal partitions featuring the diversified sequence of motifs seen in the 'classical scheme'. Most interesting is the central panel, featuring a transitional layout between the basic scheme (two registers) and the classical scheme (three registers). In this particular situation, this transition is essayed by introducing secondary motifs under the wings of the main goddess, forming a new register. The experimental character of this register is detected in its spontaneity. Quite unlike the expected motifs used in the central panel, this composition shows surprisingly innovative motifs involving *ba*-birds drinking from the water spitted out by frogs flanking the primeval lotus, from where the heavenly mother goddess rises.²⁰ It is interesting to detect this sophisticated symbolism in an object so poorly crafted, both in terms of the carpentry and pictorial work.

In this highly experimental context, the remaining features of the object display a very conservative layout. The footboard, the lower section, and the upper

20 See coffin A.18 in Brussels. In Delvaux, Therasse 2015, 93.

section remain fully attached to the usual conventions.²¹ Also conservative is the transversal alignment of the hieroglyphs in the longitudinal bands of text, a feature still rooted in the decorative scheme of the Ramesside coffins and early 21st-Dynasty.

The mummy-cover also reveals poor levels of craftsmanship (Fig. 191). The style is informal and the pictorial work is crudely executed. The layout dates from the mid-21st Dynasty, with the lateral partitions of the lower section displaying a very typical sequence of registers involving an enthroned Osiris, the avian form of Ptah-Sokar and the *ba*-bird.²² However, it is clear that this object was not manufactured together with the lid, as it was originally crafted for a man. In fact, the object reveals abundant traces of a careless process of recycling, such as the odd and rare circumstance of displaying ears together with earrings.²³ The open hands were crudely molded in plaster and the breasts were summarily sketched. The object was thus originally crafted for a man, and later on, it was adapted to be used by a woman.

A.15 Inner Coffin and Mummy-Cover

The inner lid and mummy-cover from A.15 were designed after the 'complex scheme', a layout typically found during the second half of the 21st Dynasty. The objects were clearly crafted together to be part of the same burial assemblage (Figs. 39/61). In fact, on both objects the wigs display a checkered decoration, the same central marker is found on the chest (winged scarab) and a similar composition is detected on the short collar and on the floral collar. The later in particular, plays a bold role in the overall decoration of the lid given its size, the outstanding use of colour and the minacious depiction of the floral patterns. Although surprisingly limited, the few patterns used in the decoration of the twelve bands of the collar (checkered motifs, persea-tree buds, lotus petals) are intertwined in such an effective way that its impact overshadows the remaining composition of the object.

On both objects the central panel is so exceptionally extended (nine registers on the lid and eight registers on the mummy-cover) that the lower section was excluded.²⁴ The decoration of these remarkable tableaux provides a good

21 The lower section, for example, is designed as a triptych with the central partition featuring a variety of sacred totems and the lateral partitions displaying Osiris, the avian form of Ptah-Sokar, the sacred ram, and mummiform gods. This design is typical of the classical scheme, dating from the mid-21st Dynasty. See Sousa 2018b, 136, 140.

22 See Sousa 2018b, 136.

23 The ears are typically a male attribute and were normally removed when the coffin set was adapted for a female owner. See the coffin set A.22, where the ears were removed.

24 See also coffin in Budapest (Inv. No. 51.2093/1) in Liptay 2011, Pl. 87. For the symbolism of this particular layout see Sousa 2018b, 203.

example of the informal and sketchy style increasingly detected during the second half of the 21st Dynasty. When we compare with the sophistication of the pictorial work produced on the upper section, one has the impression of looking at juxtaposed images and this clearly shows how independently the different pictorial areas were decorated. Despite the reigning ‘clumsy’ atmosphere, the composition of each register not only observes the existing guidelines as it shows learned ways of downsizing the registers while keeping their significance intact. This is particularly clear in the 7th register where, instead of the centripetal winged goddess, a winged *udjat*-eye is depicted allowing the *ba*-bird to be featured on a larger scale than in the previous registers (Fig. 44).

The texts reveal the same ‘cursive’ layout and one has the impression that the pictorial decoration has been shaped exactly under this ‘cursive’ style. Given the exceptional quality of the decoration involved in the craftsmanship of these objects, one has to admit that this ‘cursive’ pictorial work was probably not seen as a minor achievement.

A.15 Outer Lid

This lid is an imposing object profusely decorated with the typical miniaturist and highly schematic style dating from the late 21st Dynasty (Fig. 12). The prevalence of dark pigments in the colouration of the motifs and the prevalent role of the block-friezes as a bounding element also attests a very late dating. Not surprisingly, the design follows all the key-features of the ‘complex scheme’.²⁵ The large floral collar fully covers the forearms, the central panel is headed by the winged solar disk displaying four registers, and the lower section is designed as a triptych panel with the lateral partitions exclusively decorated with mummy-form gods. Last but not least, the footboard features multiple registers.

One of the most interesting features of the upper section is the central marker consisting in a pectoral displaying a solar-heart amulet, which is a later development resulting from the increasing Osirification of coffin decoration during the 21st Dynasty.²⁶ Moreover, the size and diversity of the floral patterns featured on the lid,²⁷ clearly shows the boldness of their role in the overall layout of the object.

25 For the symbolism of this layout see Sousa 2018b, 203.

26 During the 21st Dynasty, this type of pectoral is used as a symbol of the justification of the deceased, with the heart amulet illustrating the Osirian identity of the deceased and the solar disk alluding to his rebirth. See Sousa 2007, 59–70. On the Osirification of coffin decoration see Sousa 2018b, 205.

27 The floral patterns used include lotus petals, persea-tree fruits, lotus flowers and papyrus, and the checkerboard motif. See Sousa 2018b, 59.

The structure of the central panel is apparently conservative, displaying all the expected iconographic sequences. The notable exceptions are the large winged deity (here conspicuously depicted as a falcon) and the nuclear block of the third register, where the typical scarab is missing. Variations like these were frequently introduced in the later versions of the central panel, normally involving secondary motifs, probably aiming at making the object unique and 'exceptional'. However, in this particular case, the variations affect the core elements of the tableau. The result is a new reading of the central panel, featuring the heavenly goddess fully in avian form, literally flying over the deceased as the raptor is interestingly depicted from above, and not from below as it was more usual.

Given the differences between this object and the lid of the inner coffin, it is unlikely that it was crafted to be part of the same burial set.

A.60 Outer Lid

The outer coffin from A.60 is designed after the later versions of the 'complex' scheme (Figs. 144–303). The face is heavily moulded in plaster, but preserves a fine sense of proportion. The wig was striped and the large floral collar displays a monotonous and yet impressive sequence of patterns. Seemingly, a pectoral (a heart-amulet?) seems to have been painted over the floral collar on the chest.

The central panel displays three registers showing a profusion of additional blocks. Selected motifs introduce subtle variations to the expected sequences. For example, in the centrifugal blocks of the symmetric registers, a divine couple is featured, both enthroned. The long sequence of liminal elements depicted above the wings of the main goddess includes traditional motifs (such as the *shetjît*-shrine, the sacred cobras and sacred vultures) and new symbols (such as the falcon over the *nebu*-sign, scarabs and squatted mummiform gods), showing the increasing 'liminalization' of the composition typically found in the late 21st Dynasty.²⁸

The lower section is arranged as a triptych panel, displaying all the key-features pointing out to a later dating, such as the prevalent use of block-friezes to bind the vignettes and the columns of text. The lateral partitions display ritual scenes depicting the deceased clad in royal garments performing rites escorted by other gods before the enthroned Osiris.²⁹

Despite the severe damages that affect the object, it is clear that it was once an imposing artefact (Fig. 303). The pictorial work is schematic, as it is the rule in later coffins. The tableaux of the lower section revolve around the participa-

28 See Sousa 2018b, 204.

29 See Sousa 2018b, 138. For the symbolism of this layout see Sousa 2018b, 203.

tion of the deceased in the cult of Osiris, while the central panel enhances the Osirian atmosphere by highlighting the majesty of the enthroned gods flanking the main axis of the tableau. Together, these features attest the increasing 'Osirification' of coffin decoration that shapes the last stages of the 'yellow' coffins.³⁰

A.56 Outer Lid

This coffin is designed after the later versions of the 'complex' scheme (Figs. 120/300). The style, in particular, betrays a later dating, as the pictorial work is rather schematic and rigorous, revealing a careful arrangement of the composition. The main motifs are highlighted by moulded plaster and painted black against a yellow background, but the density of depiction is such that the dark motifs overshadow the lightful background creating a vivid contrast, which in Antiquity must have been even more impressive.

The face, in particular, presents an exceptional sculptural work, with the anatomical details boldly rendered, such as the nostrils. The nose and the lips are elegantly carved, reminding of the royal portraits dating from the reign of Hatshepsut.

The floral collar was not provided with terminals and the typical short collar was not depicted between the lappets either, nor was any central marker included in the upper section. The result is a heavy but nevertheless imposing composition of a massive floral collar displaying up to 22 bands monotonously decorated with just two or three different patterns.

The central panel displays a composition displayed in just three registers. A profusion of additional blocks was added to the main registers, especially on the edges. The composition is conservative and surprisingly reproduces all the key-features typically found in the 'classical' versions of the tableau.³¹ And yet, subtle details betray a later dating. For example, in the nuclear block of the third register frogs are included. However, the most interesting aspect in this composition is the role performed by the liminal elements. As usual they concentrate over the wings of the main goddess but they literally fill in all the interstitial areas of the tableau. Besides the usual motifs, such as vultures, *shentjit*-shrines, cobras and falcons, the repertoire of the liminal elements includes a mummy-form god, depicted either squatting or enthroned, perhaps the deceased himself.³² The minute attention to detail makes this composition an impressive and imposing tableau.

30 Sousa 2018b, 205.

31 See Sousa 2018b, 107/202.

32 Note that this figure is depicted in the centripetal blocks of the symmetric registers, the location where the deceased is normally depicted as a *ba*-bird.

In the lower section, the central columns of text running down the foot-board are inserted within block-friezes, which is a conspicuously late feature, already announcing the layout typically found in stola-coffins. The columns of text divide the lower section into three partitions arranged in three registers. The central partition displays symmetric compositions, some of them observing the usual layout, using the scarab as the nuclear block, while others already display innovative arrangements making use of hieroglyphic signs (such as *tjet*-sign) as nuclear blocks,³³ which is a conspicuously late feature.

The lateral partitions reveal a far more interesting composition, displaying ritual scenes depicting the deceased clad in royal garments performing rites before the enthroned Osiris, protected by a large winged deity.

The overall impact of the lid is outstanding, with the dark and profuse winged motifs predominating all over the object, suggesting, perhaps in a 'subliminal' manner, a subtle and suggestive association with a *rishi* coffin. Such prevalence of winged motifs is difficult to match in contemporary artefacts.³⁴

As it is usual in later coffins, the deceased wears dark tight royal garments (typically kilt and shirt) instead of the white festive garments found early on (see inner lids from A.22 and A.60). These changes are naturally related to the perceived differences in the status of the deceased who is no longer depicted simply as a priest, but rather as a god provided of 'royal' dignity.

1.2 *The Cases*

A.20 Inner Case

The features of the case are highly consistent with those found on the lid, suggesting an early dating. The most conspicuous feature in this respect is the absence of decorative friezes bordering the upper edges, which would be expected in objects dating from the late Ramesside Period (Figs. 75/79). The decorative program however, seems rather 'intrusive' in such an early context, as we find a relatively large repertoire of scenes, instead of the usual depiction of the four Sons of Horus, Osiris and other deities from the nether-world.³⁵

The style is roughly executed and the depictions of the deceased show her clad in white folded garments, also features suggesting an early dating. The decoration of the sides is almost symmetrical. The upper sections are designed

33 See Sousa 2018b, 142.

34 A similar design can be found on the outer case of A.142. See Egner, Haslauer 2009, Pl. 29.

35 See coffin of Nesiamun (Leeds City Museum D. 426–426a.1960) in Cooney 2007, fig. 187. See also coffin of Tabasety, in Sousa, Nørskov (forthcoming).

exactly in the same way,³⁶ while the lower sections display subtle differences, playing with complementary meaning.³⁷ Despite the crudeness of the execution, the iconographic program of the sides observes a well-planned scheme of decoration, with the upper section celebrating the resurrection of Osiris and the lower section featuring the initiation of the deceased in solar-Osirian rituals and her admission before the mother goddess of the necropolis.

The textual corpus is highly consistent with the iconographic program, mentioning exactly the same deities featured in the vignettes, including invocations of Osiris, as the king of the netherworld (left side) and Re-Atum-Kepri, as primeval deity (right side), thus reinforcing the Osirian significance of the left side and the solar association of the right side.

A.60 Inner Case

The decoration of the case reveals key-features clearly dating from the first half of the 21st Dynasty. The upper edge shows the typical frieze featuring alternating cobras and feathers (Figs. 179–183). The style is naturalistic, slightly informal and sketchy, but beautifully executed. The compositions are harmonious and the figurative depictions are expressive. The deceased wears white festive garments and she is gracefully depicted, revealing a skilled pictorial work.

The inscriptions reproduce the classical repertoire of texts, closely resembling the scheme used in the case from A.20. The decoration of the sides is highly symmetrical,³⁸ with the major difference detected next to the footboard: the last vignette of each side introduces the idea of a blessed afterlife either in the form of a successful outcome in the judgement of the dead (*Vignette 16*) or by being admitted before the tree/mother goddess (*Vignette 9*).³⁹

The interior of the case features a sole and imposing depiction of the mother goddess, presiding over the West, painted on a red background with the edges marked in yellow (Fig. 302). Although this would be the expected composition in an earlier coffin, it is clear that this ‘archaizing’ atmosphere was the result of a later arrangement. In fact, behind the layer of red paint, one can detect

36 Thoth is depicted before Osiris laying on a bed (*Vignettes 4–5*, *Vignettes 10–11*).

37 The deceased is depicted performing rituals before the solar barque (*Vignettes 12–13*) or before the Ta-wer totem (*Vignettes 6–7*). Next to the foot-board, the mother goddess is featured as a sacred tree (*Vignette 15*) or as a sacred cow (*Vignette 9*).

38 Both upper sections depict Osirian scenes—as an enthroned god on the right side (*Vignette 12*) or as the Ta-wer totem on the left side (*Vignette 5*). The lower section of both sides display the same scenes: the deceased (*Vignettes 6, 13*) before the solar barque (*Vignettes 7, 14*) and the divine triad over Mehen (*Vignettes 8, 15*).

39 A variation to this scheme can be found in the case of Ankhesenmut. See Dodson 2015, 20.

motifs and inscriptions that had been covered up with red paint. This operation clearly aimed at giving to the object an ‘archaizing’ look, perhaps with the purpose of enhancing its value as an antique.

It is interesting to point out the quality of the pictorial work in contrast with the carpentry work, which is mediocre. The painter wonderfully succeeded in transforming a poor artefact into a beautifully designed work of funerary art. One should also note that this mastery is not equaled in the decoration of the lid, suggesting a different provenance.

A.22 Inner Case

The features of the case are highly consistent with those found on the lid, dating from the mid-21st Dynasty. The typical frieze featuring alternating cobras and feathers is found along the upper edge, the style is naturalistic, detailed, and well executed (Fig. 103/106). The deceased wears white festive garments. Despite the superior levels of craftsmanship, it is surprising to find a repertoire of texts poorer than in the coffins previously discussed, including rather repetitive invocations of Thoth, Osiris, and Isis.

The most interesting fact to retain about this object is the layout observed on the sides. The upper section, on both sides, features Thoth witnessing to the cosmological scene of Geb, Shu, and Nut (*Vignettes 5–6*) or to the mysteries of the Osirian mound (*Vignettes 2–3*). However, the lower section is designed as a single pictorial tableau featuring juxtaposed scenes: adoration to Osiris and the manifestation of Hathor as a divine cow (*Vignette 4*); judgement scene, winged scarab, divine triad on the Mehen serpent, and the tree-goddess (*Vignette 7*). In this innovative scenario the decoration of the side-panels of the headboard is strikingly conservative, featuring a striped pattern which would be expected in much older coffins.⁴⁰

A.15 Inner Case

The scheme of decoration of the case is consistent with the layout found on the lid, pointing out to the second half of the 21st Dynasty (Figs. 50/53). The upper edge of the sides display alternating cobras and feathers, a band of inscriptions and block friezes. The style is schematic, informal, sketchy and crudely executed. The compositions are carelessly designed and the proportions are unbalanced.

Despite naming the title Chantress of Amun in the inscriptions, the deceased is always depicted as a male, wearing tight dark garments, showing a

⁴⁰ See coffin of Tabasety, in Sousa, Nørskov (forthcoming).

clear inspiration on royal archetypes (only once the deceased is depicted wearing white garments and the heart amulet). He is also depicted as a mummiform god and as a male *ba*-bird. The depiction of the deceased as a male may have been intentional, even if the targeted user of the coffin was a woman. In fact, the male depiction of the deceased possibly aimed at stressing the royal status achieved in the afterlife.

Oddly enough, liminal elements are not included yet, as would be expected given the later dating of the object. The quality of the inscriptions, both on the case and on the lid, is also very sketchy, with the hieroglyphs summarily traced, in a rather cursive way.

The layout of the sides reveals a full horizontal arrangement, with the multiple scenes packed under the same vignette, a trend already detected in the arrangement of the scenes on the case of A.22. The traditional division between the upper section and the lower section is totally blurred and with that the position of the motifs seems to become more fluid than before.⁴¹ The scenes included in the repertoire of this case form an iconographic compendium merging traditional solar motifs such as the cosmological scene of Geb and Nut, the victory of the solar barque over Apopis, with the new motifs borrowed from the repertoire of the royal Books of the Amduat, featuring endless variations of mummiform gods of the netherworld.⁴²

The interior decoration could not be more contrasting, revealing, one could say, a timeless atmosphere clearly embedded in the Ramesside pictorial tradition. The impressive effigy of the goddess Neith is beautifully depicted, shining against a starry reddish sky.⁴³ The imposing frontal view of a raptor heads this outstanding composition, heavily decorated with large-scale liminal elements (vultures and cobras) and deities of the netherworld.

The decoration of the floorboard suggests a narrative reading allusive to the solar regeneration in the Amduat. The lower register shows the rise of the sun disk in the netherworld and the first register features the ascent of the solar barque to the sky, flanked by *ba*-birds. The going forth by day is vividly suggested by the raptor rising on the headboard.

41 The noticeable exceptions are the scenes of the cow and the goddesses which retain their traditional association with the foot-board, as well as the Geb and Nut scene, here associated with the upper section.

42 The inner coffin of Gautseshen in Leiden provides striking resemblances with this layout. See Mann, Greco, Weiss 2018, 41.

43 The dress is decorated with a sophisticated pattern painted with contrasting yellow and white motifs. It is interesting to note that the yellowish effect was here added by simply using varnish in selected areas of the composition. See inner coffin of Gautseshen in Leiden. See Mann, Greco, Weiss 2018, 41.

The sophistication reached in the interior decoration of this coffin is outstanding and it is even more surprising when we consider the ‘cursive’ pictorial work detected on the exterior decoration of the sides. Such contrast is observed in other burial assemblages found in Bab el-Gasus and it was certainly not accidental.⁴⁴

A.15 Outer Case

The exterior decoration of the case reveals key-features consistent with the layout found on the lid, dating from the second half of the 21st Dynasty (Figs. 24/28). The edges of the sides display the typical frieze featuring alternating cobras and feathers, and a long band of inscriptions. The style is naturalistic, rigorous, extremely well executed. The compositions are carefully designed and the proportions are good. The deceased always wears dark tight garments and liminal elements are parsimoniously used.

The iconographic program carries out an update of the traditional scheme in use during the first half of the dynasty. On both sides, the upper section includes two vignettes, forming a single scene depicting the god Thoth (*Vignette 4*, *Vignette 9*) standing before a shrine. However, instead of the expected depictions of Osiris or Ptah-Sokar, two mummiform cobra-headed gods borrowed from the repertoire of the Books of the Amduat are featured (*Vignette 5*, *Vignette 10*). The decoration of the lower section replicates very closely the models of old,⁴⁵ but again, two mummiform enthroned cobra-headed gods (*Vignette 14*) betray the later design of the object.⁴⁶

The depiction of the gods of the netherworld described in the Amduat on the sides of the cases is attested slightly after the mid-21st Dynasty.⁴⁷ The interesting fact about this program is the attempt to achieve a learned synthesis between the new visions of the hereafter with the old archetype.

44 See the inner coffin of Gautseshen in Leiden. See Mann, Greco, Weiss 2018, 41.

45 On both sides, two vignettes (*Vignettes 6–7*, *Vignettes 11–12*), form a single scene depicting the deceased offering before the solar barque. This scene is reproduced on both sides with subtle variations: on the right side, the triumph over Apopis is illustrated (*Vignette 12*), while on the left side the regeneration of Osiris is depicted (*Vignette 7*). On the left side, the closing scene depicts Hathor in her Theban bovine manifestation next to the tomb and the desert mountain (*Vignette 8*), while on the right side figures the triad on the twisted body of Mehen (*Vignette 13*), which is also a traditional motif.

46 A similar program is detected in the outer coffin of Ikhy (Vatican 25035). See Gasse 1996, Pl. XVI. See also Cooney 2014, 57.

47 One of the earliest coffins almost entirely decorated with these motifs is the coffin of Djedmutiuesankh (A.110) in Sousa 2017a, Pl. 54–55. This trend was further developed along the second half of the 21st Dynasty. Later examples are to be found in the anonymous coffin

The corpus of texts provides a similar picture. The calligraphy is excellent and the repertoire of texts observes the tradition by including the usual inscriptions alluding to the protection granted by Thoth, Re-Atum-Kepri and Ptah-Sokar. At the same time, 'new' and fairly diversified texts are introduced referring to the gods of the netherworld, here associated with the Manu Mountain, the West and the necropolis. However, the most innovative texts are surely those inscribed on the bands of text found along the edges, associating the deceased to the solar circuit in the sky and to the community of gods resting in the netherworld. This is by far the best repertoire of texts found on the coffins from Lot v.

The interior decoration is outstanding. The repertoire includes traditional motifs such as the depiction of the large *ba*-bird on the headboard and the imposing depiction of Osiris as a *djed*-pillar on the floorboard. Other motifs found on the floorboard form sophisticated cryptographic compositions, such as the depiction of the sun-disk springing from a panther's head flanked by sphinxes, allusive to the 'horizon of light'. Inside the sun disk, protected by the twisted body of the serpent Mehen, figures the *udjat*-eye and the *ba* depicted as a stork. Below the large Osirian *djed*-pillar figures another cryptographic depiction with the Mehen serpent involving a squatting donkey-headed god.

This lavish atmosphere seems rather 'timeless' as the interior decoration remained less affected by the constant change of the principles of composition. In a way, the sacredness involving this area preserved it from constant additions. The sides of the walls however reveal subtle clues attesting to the later dating of the object. The sides are arranged into three registers, each one depicting an enthroned god inside a shrine. Here, the block-friezes are conspicuously included in order to highlight the scenes. This unexpected use of block-friezes in the interior decoration is consistent with the prevalent role they play in the decoration of the lid and the exterior walls of the case.

A.60 Outer Case

The key-features detected in the exterior decoration are consistent with those found on the lid, suggesting a later dating (Figs. 154/158). The edges of the sides display the typical frieze featuring alternating cobras and feathers, together with a band of inscriptions. The style is schematic, fairly executed. The compositions are informally designed but the proportions are good. The deceased wears the same dark tight garments shown on the lid.

(A.27) in Sousa 2017a, Pl. 28–29, and in the anonymous coffin kept in Florence (2157) in Cooney 2014, 61.

The layout of the sides reveals a full horizontal arrangement. The exceptionally long vignettes (*Vignettes 4–5* on the left side, *Vignette 6* on the right side) illustrate the performance of rituals, reminding the repertoire of temple decoration.⁴⁸ Even if traditional motifs are depicted—such as the cow goddess—one has to keep in mind that this subject is borrowed from temple decoration, namely from the Hathoric shrines at Deir el-Bahari.⁴⁹

In the bands of text inscribed along the edges of the case the association between Re-Horakhty-Atum and Osiris prevail, which is consistent with the iconographic program.

It is noteworthy the clear identification of the deceased with Anubis, here depicted as the divine archetype of the ritual performer/deceased. The result achieved by this program is the symbolic equation of the outer coffin with a sacred chamber where the deceased is provided with ‘royal’ dignity, performing a variety of rituals before Osiris and a wide assembly of solar gods. This association of the coffin with temple scenes engage the deceased in the reenactment of the cosmic order and gives him a ‘royal’ aura.

From the artistic point of view, the interior decoration of the case does not match the high standards previously discussed regarding the cases from A.15. The composition is highly unbalanced with the floorboard featuring a standing Osiris flanked by large liminal elements arranged in multiple registers, instead of being loosely depicted around the main figure, as it was the rule. Moreover, other netherworld deities were included in the registers below. The result is a rigid organization of the floorboard in several sub-registers, a trend which will be further continued in *stola*-coffins with much better results.⁵⁰

When taken together, both the interior and the exterior decoration are deeply embedded in the models provided by temple decoration and result from a new understanding of the coffin as a (private?) sacred chamber.

48 This type of program is normally associated with a horizontal arrangement of the scenes, fully suggesting the association of the sides with walls. For a similar program see the outer case of A.131 in Delvaux, *Therrase 2015*, 105.

49 The scene with the solar barque (right side) introduces yet another subject, being a subtle allusion to the Book of the Amduat here quoting the 11th Hour (see Hornung, 1999, 52). For the use of the motifs of the Book of the Amduat in coffin decoration see Araújo Duarte 2017. See also inner case of Butherkhonsu (A.52) in Küffer 2017, 252, and outer case (A.131) in Delvaux, *Therrase 2015*, 105.

50 The last register is particularly interesting, illustrating a ritual performed by a goddess before two enthroned gods. Scenes like these, almost independent from the rest of the composition, will also become frequently depicted in *stola*-coffins.

A.56 Outer Case

The exterior decoration of the case reveals key-features clearly dating from the late-21st Dynasty. Both edges of the sides display block friezes and a band of inscriptions (Fig. 131–135). The calligraphy is sketched. The style is schematic, and roughly executed. The compositions are informally designed and the proportions are unbalanced. The deceased always wears dark tight garments. Liminal elements are parsimoniously used, but ritual objects and offerings are prevalent as space-fillers. These elements are carelessly displayed creating a confusing atmosphere that disturbs the composition as a whole.

The layout of the sides is strongly asymmetrical. The right side reveals a conscious update of the traditional scheme in use during the first half of the dynasty, keeping the distinction between the upper section and the lower section. Besides traditional scenes featuring the *Ta-wer* totem (*Vignette 10*), the recumbent Osiris (*Vignette 7*), and an abbreviated judgement scene (*Vignette 8*), ritual scenes involving the gods of the netherworld are included (*Vignettes 9–11*). The left side displays only three vignettes, showing a predominant horizontal arrangement. The *Vignette 2* gathers a variety of ritual scenes where the gods of the netherworld play a prevalent role. Moreover, on both sides, the deceased is largely outnumbered by goddesses, who play a bold role in the cult.⁵¹

In this context, the deceased is depicted only on three occasions: in one circumstance he is escorted by goddesses (*Vignette 4*) and in two others he performs rituals (*Vignette 4*, *Vignette 8*). The profuse depiction of these netherworld goddesses seems to be related to the Theban manifestation of Hathor (*Vignette 5*). This unusual program is an achievement of its own, despite the poor levels of execution, which hardly match the quality detected on the lid. The two objects thus must have been crafted separately.

The interior decoration must have been truly impressive. The sides display excellent levels of quality in terms of pictorial work and the use of block-friezes to bind the registers also betrays a late dating.⁵² The floorboard is severely damaged.⁵³

51 A slightly similar program is detected on the inner case of A.26. See Egner, Haslauer 1994, Pl. 24.

52 See Walsem, 1997.

53 Unfortunately, Daressy did not report any information concerning the examination of this mummy, but it is likely that the corrosion detected on the floor-board resulted from the use of lime and natron, such as it was reported in the burial of A.20.

2 The Funerary Assemblages

2.1 *Coffin Set of Djedmutiuesankh (A.15)*

The outer coffin is the latest object of this coffin set. This is clear in the formal arrangement of the scenes as well as in the prevalence of the block-friezes on both the lid and the case. Although also from a later date, but slightly earlier, the inner coffin and the mummy-cover were visibly crafted together to be part of the same burial assemblage. The organization of the scenes is highly informal both on the lid and on the sides, with the different elements drawn or painted in a very sketchy way. Despite this hasty atmosphere, the design of the inner coffin, as a whole, did not result in careless work. In fact, the blur of the frontiers between different sections, is consistently observed on the sides, on the lid and on the mummy-cover. In this process, the scheme of decoration of the central panel prevailed and the 'cursive' layout detected in the pictorial work perhaps served this purpose.

Any of the objects of this coffin set was produced under commission. All the objects remained anonymous despite the spaces left blank to write down the name of the deceased. The assemblage of the outer coffin with the older coffin set certainly occurred shortly before the burial in the Tomb of the Priests. The name of its ultimate owner, the Chantress of Amun Djedmutiuesankh, was found by Georges Daressy only on the Osirian shroud that covered the mummy.⁵⁴ Given the outstanding quality of the coffins involved in this burial set, it is surprising that the notes provided by Daressy describe a poor funerary equipment, consisting in eight long robes wrapped around the corpse and a simple undecorated stone positioned on the chest, instead of the heart scarab.

2.2 *Coffin Set of Tauhenut (A.20)*

This coffin set poses interesting questions on the funerary pragmatics of the late 21st Dynasty. The coffin seems to have been crafted in the early 21st Dynasty and it is doubtless the earliest artefact found in this collection. Its mediocre quality is perhaps one of its most interesting features, as it is uncommon finding at this early stage objects produced with such inferior levels of craftsmanship.⁵⁵ One of the few parallels is the coffin of Pahereniset, found in Deir el-Medina,⁵⁶ which shows striking similarities in the proportions and treatment of the face. Both objects show that, at this early stage, the production of body containers started to include less luxurious objects, a trend that would only be

54 Daressy, 1907, 22.

55 See Cooney 2014.

56 Egyptian Museum in Turin (10108.a-b). See Niwiński 2004, Tav. XIV.

quantitatively expressive during the second half of the 21st Dynasty. Despite the poor levels of craftsmanship, the iconographic program of the coffin provides a meaningful set of images and texts suggesting that it was crafted in a workshop that started to address the needs of a lower elite, which otherwise could not afford the luxurious items that were predominately available.

It is uncertain whether the coffin remained anonymous or not since the foot-board of the lid was lost.

The coffin was surely removed from its original burial ground and became later available to be reused.

As Kathlyn Cooney pointed out, the mummy-cover shows traces of having been recycled in order to be used by a woman. Given the similarity between the inscriptions of the lid and the mummy-cover, it is possible that both objects were inscribed during this operation aiming at creating a coffin set.

At the moment of its reuse in Bab el-Gasus, the coffin set was used to bury the mummy of a young woman. It is noteworthy that the ritual gloves and the funerary scroll remained the most important artefacts found with this mummy, both meaningful in terms of her priestly service. Given this context it is not clear the purpose of lime and natron found inside the case, surrounding the mummy.⁵⁷

We are fortunate enough to have a short report published by Daressy on his examination of the this mummy.⁵⁸ The mummy was covered with an undecorated shroud wrapped up with two longitudinal bands and five transversal bands, together with uninscribed linen mummy braces. Inside, another piece of cloth was found, this one covered with an Osirian effigy outlined in black and a hieratic inscription bearing an offering formula dedicated to the "Lady of the House, the chantress Tauhenut".⁵⁹ Over this shroud leader mummy braces were found with illegible inscriptions. Only two layers of linen cloths were wrapped around the mummy. Daressy reports the low quality of these cloths and observes that the right arm was wrapped with a pair of long gloves adorned with a blue band, while the left arm was also covered with a pair of undecorated gloves. Between the legs, Daressy found a funerary papyrus and on the embalmer's incision, a wax plate was found.⁶⁰ The mummy was found in a good state of preservation and revealed a young woman, 1,60 m tall with long black hair. The ears were abnormally long due to the use of heavy earrings

57 Daressy 1908, 23.

58 Daressy, 1903, 155.

59 Daressy, 1907, 23.

60 Daressy, 1903, 155.

during her life. Nevertheless, insects were found in her mummy suggesting that it remained ‘in storage’ during an undetermined length of time before its definitive wrapping.⁶¹

The description provided by Daressy suggests that the corpse was very well preserved. The quality of the mummification procedures and the elongated ears suggest, if not a high rank, at least an important social status achieved by this woman during her short life. The poor coffin set provides an interesting contrast with the relatively rich funerary equipment associated with the mummy and seems to have been purely opportunistic, rather impersonal and it probably occurred shortly before the burial in the tomb.

2.3 *Coffin Set of Khonsumes (A.22)*

The coffin set dates from the mid-21st Dynasty. The most interesting feature of this coffin set is the decoration of the sides, showing a semi-horizontal arrangement. The lower sections, in particular, are decorated with a single vignette compiling several scenes. This arrangement of the decoration reminds the layout seen in unfolded papyri.⁶² In fact, this resemblance is particularly striking with the so-called ‘mythological papyri’, or Amduat papyri, consisting in iconographic compilations of the scenes of the hereafter. This subtle association of the coffin sides with a funerary book perhaps is not accidental and possibly aimed at highlighting the ‘intellectual’ or ‘erudite’ status of the owner, originally Khonsumes, a scribe in the temple of Amun.

At a certain moment, this burial equipment was removed from its original burial ground. It was then recycled aiming to be used by a woman. Some changes have been carried out such as the removal of the fists, ears, and beard. Consequently, open hands were added, as well as the depiction of earrings. However, many of the male features were kept, such as the striped wig, as well as the depictions of the deceased on the lid and on the sides. This is probably due to the perceived value of the coffin set as it was, by the time it was recycled. Since the examination of the mummy was not recorded by Daressy, we don’t have any information about the last owner of this burial set, who remained anonymous.

2.4 *Outer Coffin of an Anonymous Man (A.56)*

This outer coffin presents transitional features close to the *stola*-type and it is certainly the later object of this collection. The lid displays, by far, a much bet-

61 Daressy 1907, 23.

62 See, for example, the funerary papyrus of Khonsumes in Vienna (Piankoff 1957, 143–147) or the funerary papyrus of Nesipakashuty in the Louvre Museum (Piankoff 1957, 104–109).

ter work than that observed on the case itself, which suggests that they were crafted independently.

The nose and the lips featured on the lid are elegantly carved, reminding of the royal portraits dating from the reign of Hatshepsut. This resemblance may not be hazardous and, Kathlyn Cooney points out in the same direction adding that the coffin once displayed a headdress, which, given this early context, could only have been a vulture headdress. If so, the object in question was most likely part of a *rishi* coffin, thus with a royal provenance. If so, the object was certainly 'rescued' from the royal necropolis during the 21st Dynasty and, after having its original (gilded?) decoration ripped off, it was prepared to be reused. Typically, female *rishi* coffins did not include ears, and those depicted on the lid are moulded, resulting from the recycling work carried out during the late 21st Dynasty, which originated the outstanding piece seen today.

The case, on the other hand, is crudely crafted. Yet, the iconographic elaboration achieved in this object is an achievement on its own—celebrating the role of the mother goddess in the Osirian regeneration—even if the artistic skills did not match the high standards detected on the lid. The object seems to have been reused and taken from another burial assemblage. The reuse of this object is partially explained due to the fact that the recycling of the lid required the acquisition of a new case, as royal *rishi* coffins would have rounded boxes, thus inadequate when rectangular coffins were no longer in use.

Once finished, the coffin was seemingly very valuable and that might explain why it was not used together with further equipment. It is noteworthy that the empty space for the name of the deceased remained uninscribed on the lid.

2.5 *Coffin Set of an Anonymous Woman (A.60)*

Any of the objects found in this burial assemblage was crafted together to be part of the same coffin set. The differences in style are striking. The oldest object found in this burial assemblage is the inner case dating from the first half of the 21st Dynasty. The lid of the inner coffin is a slightly later work, dating from the mid-21st Dynasty. Both were crafted to be used by women.

The mummy-cover dates from the mid-21st Dynasty. The object was originally crafted for a man, but it was later recycled and adapted to be used by a woman. Perhaps at this stage, it was inscribed with the name Ankhsemmut.

The final decoration of the outer coffin dates from the late 21st Dynasty. At some point, it was prepared to be used by a man. The name of a man, Ankhefenkhonsu, was indeed found on the case (Inscription 1).

Given this scenario, it is clear that the objects belonging to this burial set were assembled at a later date, probably shortly before its deposition in Bab el-Gasus. The burial assemblage as a whole seems particularly careless in the

way it groups male and female objects, as well as highly asymmetric objects in terms of quality and dating. The outer coffin has a relatively good craftsmanship, the inner coffin show fair levels of execution, while the mummy-cover displays nothing but a mediocre quality.

Perhaps more important is the assemblage of objects visibly old (inner coffin and mummy-cover) with others that would be perceived as ‘new’ (outer coffin). The inner coffin in particular, was recycled in order to look even older than it was. Not only the case had the interior decoration rearranged, as another lid, displaying a rather ‘eccentric’ central panel, was associated with it. It is also to be noted that the longitudinal bands of text of the inner lid observe the transversal alignment of the hieroglyphs, which would be recognized as a very archaic feature.

These contrasting features truly make this coffin set, an assemblage worthy of a *connoisseur*, which in any case remained anonymous. It is very unlikely that the name inscribed on the mummy-cover corresponds to the final owner of this coffin set. Daressy reports that among the burial equipment of this mummy, a shroud inscribed in hieratic with the name Djedmut was found. This clew alone, hardly provides the identity of the deceased, as Daressy found among the linen wrappings of the mummy, a tunic inscribed with yet another name, Henuttaui.⁶³ Given these elements, the only thing we can be sure about is the extension of reuse of funerary goods, which was extended to shrouds and cloths. It is likely that the deceased buried in this coffin set was a woman.

One final word should be addressed regarding these burial assemblages. This reconstructed scenario has necessarily to consider the position of these burials in the tomb. For the moment, the hastiness detected in most of these assemblages cannot be extrapolated to the whole tomb. Based on this examination alone, it would be dangerous to consider that all the burial sets found in Bab el-Gasus were gathered in a similar (careless) way. On the contrary, this seems to be the result of the circumstances that surrounded the definite closing of the tomb. Evidence found in the tomb suggests that it was sealed before its full capacity has been achieved, perhaps to avoid the plundering of the main burials kept in the funerary chambers.⁶⁴ The burials positioned next to the entrance, such as those examined in this book, would have been, for practical reasons, the last ones to have been positioned in the tomb and probably were assembled hastily given the imminent need to seal Bab el-Gasus.

63 Daressy 1907, 27.

64 Sousa 2018a, 25.

3 The Tomb of the Priests and the Corporative Values of the Priesthood of Amun during the Late 21st Dynasty

The stylistic analysis of the burial assemblages from the Lot v makes clear that there is no uniformity in terms of chronology in the objects found in Bab el-Gasus. Unlike the usual pattern, this undisturbed archaeological site did not reveal a sample of objects dating from the same period, as we could expect from a burial ground that was active during a relatively short period of time. On the contrary, the tomb revealed objects dating back from the late Ramesside Period to the late 21st Dynasty. In fact, even in the same coffin set objects with different dating can be easily found. Stylistic data thus confirm the idea put forward by Kathlyn Cooney that most of the coffins buried in Bab el-Gasus had been previously used, normally in a repeated manner, during the 21st Dynasty.⁶⁵

In most of the burial assemblages from Lot v it is relatively clear that the objects were assembled shortly before their deposition in the galleries of Bab el-Gasus. At this stage of our knowledge, it is difficult to grasp the criteria underlying the decisions behind the assemblage of each coffin set. In some cases, the burial assemblage seems to be the result of a quite hazardous process.

The Italian Lot clearly shows different ways to form a coffin set. In general, the inner coffin and the mummy-cover were taken from an original funerary ensemble. This leads us to the idea that once the coffin sets were recovered from the original burial ground where they were stored together, probably with the mummy-covers kept inside the inner coffins.

The burial sets thus seem to have been methodically assembled out of the resources available at a given—certainly huge—storeroom, and not from the simple reuse of coffins from older caches. In fact, evidence of a careful management of the funerary goods is found in the Lot v. In some situations, these storerooms kept the integrity of the original assemblages, while in others, the cases, lids and mummy-covers seem to have been stored separately. This explains the eclectic combination of cases, lids, and mummy-covers from different burial sets.

Moreover, strategies regarding the recycling of an object also seem to have been decided and coordinated centrally, perhaps by the same individuals that managed the storerooms of the necropolis.

The use of outer coffins seems to have increased by the late 21st Dynasty and that might explain the combination of older objects with later outer coffins (such as we observe in A.15 and A.60).

65 See text by Cooney in this volume.

At this stage, when a burial assemblage was formed, the available objects were combined most probably according to practical reasons. Such a pattern leads us to the obvious conclusion that in most of the coffin sets, the study of the symbolic associations between the inner and the outer coffin is difficult to grasp, if not impossible, as in most of the cases they result from a hazardous and opportunistic association.

This is even more disturbing when we realize the tremendous effort put forward in the craftsmanship of these objects. Despite the political and economic hardships affecting the Egyptian territory, Theban workshops excelled both in terms of the technical skills and conceptual work.

The stylistic evidence from Lot v suggests that, despite the huge number of objects in storage, Theban workshops remained fully active during the late 21st Dynasty. The coffins produced at this later stage show a consistent sample of features. The figures are rendered with highly standardized features as if depicting hieroglyphs, rather than individuals. Another common feature is the dark colouration of the garments and the inclusion of an increasing number of liminal elements between the figures. The depiction of the deceased is often impersonal and a kingly figure is depicted instead (coffin A.56, outer coffin from A.60 and inner coffin from A.15).⁶⁶

This trend is consistent with the increasingly anonymous character of the coffins as we approach the end of the 21st Dynasty. One of the most intriguing aspects of the coffins examined in the Lot v is the anonymous character of the objects, even in the most splendid ones. The outer coffin from A.15 is particularly revealing. Although this is visibly a high quality item, the object remained anonymous despite the spaces left blank to write down the name of the deceased in the inscriptions of the lid and the case. The name of its ultimate owner, the chantress of Amun Djedmutiuesankh, was found by Georges Daressy on the Osirian shroud only.

A similar situation is observed in the remaining burial assemblages. The identity of the owner of the coffin set from A.20, the lady Tahumet, is only sug-

66 Older objects are more naturalistic in style. In such objects, the artist pays great attention to the depiction of the anatomical details and the figures are depicted in relatively spontaneous compositions. The garments are white and liminal elements are not used. See Sousa 2018b, 175. Short inscriptions are used instead, filling in the upper areas of the vignettes or the empty space between the figures. The coffin from A.20 displays a rough version of this style, featuring a sketchy and rather informal composition, while the inner case from A.60, although not exactly of high quality, showcases a much better work in terms of execution. In our sample, perhaps the best version of this style is detected on the objects from A.22.

gested by the inscription found within the mummy wrappings and a similar situation occurs with the coffin set from A.60, where the identity of the final owner remains unknown. The coffin set from Khonsumes (A.22) was recycled to be used by a woman, but we don't have any information about its final owner. A similar situation might have occurred to the coffin from A.56, which remained anonymous. With the exception of A.56, it is thus likely that all the mummies buried in the coffin sets from Lot v might actually have been women.

These occurrences make clear that these superb coffins were produced without the previous commission of specific individuals. The anonymous character of these objects suggests that their assignment to a particular individual did not result from an individual acquisition—in that case, we should expect that at least the name of the deceased would be written over it.

Quite unlike the usual pattern detected during the New Kingdom and possibly still active during the beginning of the 21st Dynasty, coffin manufacture during the second half of the 21st Dynasty was no longer dictated by the commission of private individuals. Instead, the examination of the documental corpus from Bab el-Gasus suggests that coffin production was centrally managed by the priesthood of Amun, who, from the middle of the dynasty onwards, managed the craftsmanship of new coffins, the recycling of reused coffins and the storage of reused objects. These goods could then be used (possibly indefinitely as Kathlyn Cooney rightly suggests) as retribution to its own members, not in a personal way, but according to their rank in the priesthood of Amun.

This process, certainly required the storage of coffins and funerary artefacts which were assembled in the storerooms of the necropolis so that they could be periodically recycled and re-distributed.⁶⁷ While doing so, the priesthood of Amun established new patterns not only in the use of the burial grounds of the necropolis—which became corporative as the Tomb of the Priests superbly shows, rather than familial as it happened during the New Kingdom—but also in the way funerary goods were acquired. These were no longer bought by an individual or a family, but redistributed by a professional corporation to its own members. In this process, the redistribution of the burial equipment to a certain individual was decided according to his/her rank in the priestly corporation and probably he/she did not play any role in this process. This certainly explains the anonymous character of most of the coffins dating from the late 21st Dynasty.

67 Sousa 2014, 106–107.

Given these circumstances, it is surprising to find that coffin decoration did not turn itself into a meaningless process. The personal attachment between an individual and the body container was definitely gone and with that, the deceased becomes depicted in a rather impersonal manner.

It is the collective identity of the priests and priestesses of Amun that is celebrated in these coffins and not the individual himself. This explains why coffin decoration evolved continuously in its quest for meaning. Certainly the individuals did not play any role in the decoration of coffins, but exactly because of that, each one of the priests could relate to the scenes featured on the coffins as if they were sacred chambers where he was acclaimed with kingly or divine honours.⁶⁸ Not hazardously, the inspiration in the royal Books of the Amduat is behind many of the iconographic elaborations involved in coffin decoration,⁶⁹ but perhaps more important is the increasing sacredness associated with the coffin itself. In most of the coffin sets, the decoration of the interior walls reveals a retrograde taste, featuring a level of quality in terms of pictorial work much higher than the exterior walls. This contrast enhanced the sacredness of the interior of the coffin, which is truly seen as a sacred chamber. It is in this context where we find some of the most outstanding achievements in terms of pictorial art, such as the wonderful work carried out in the inner coffin from A.15. It is this sacred atmosphere, so fully rich in meaning and magic that explains the boldness of the role performed by coffin decoration in the corporation of Amun. Being cocooned, nourished and protected in such splendor would be the ultimate reward for those who served in the Temple of Amun.

68 In the outer cases from A.60 and A.56, the iconographic program is clearly borrowed from temple decoration in order to suggest the identification of the coffin with a temple. Identical process is used in the coffin 25021, kept in the Vatican Museums. See Gasse 1996, Pl. XXVIII.

69 See Araújo Duarte 2014, 89. See also Liptay 2014, 75–76 and Taylor 2010, 132–140.

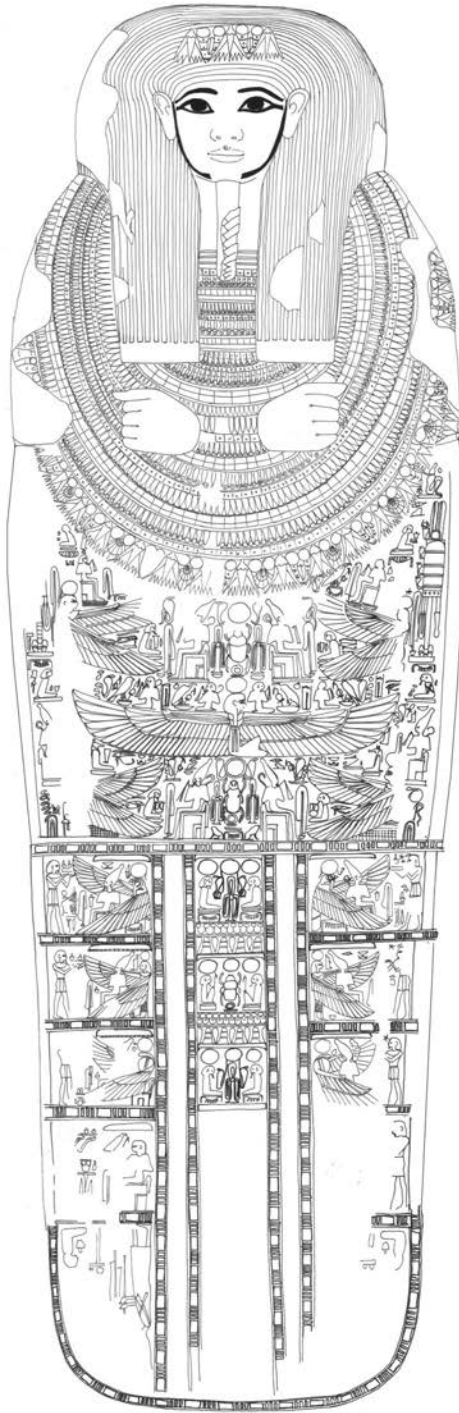

FIGURE 300
Outer lid (A.56)

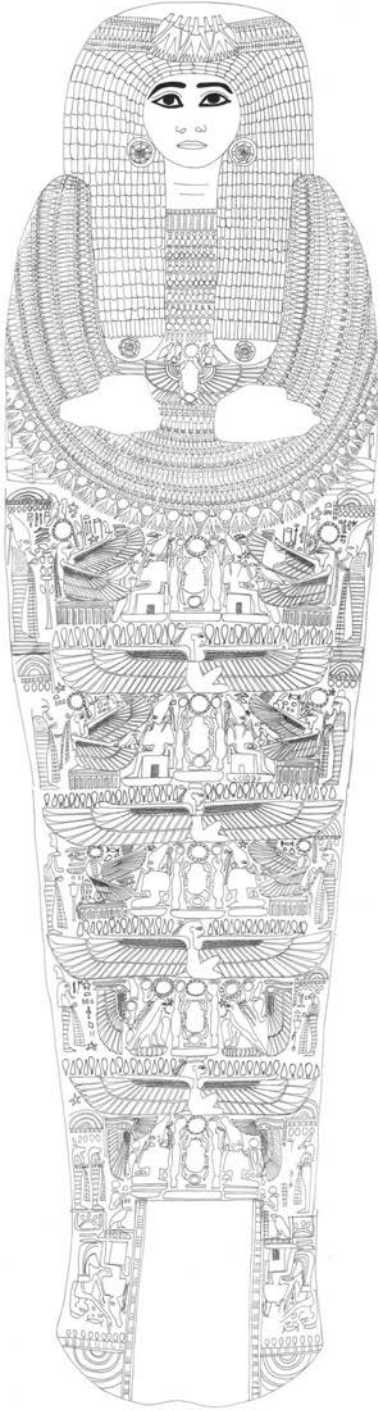

FIGURE 301
Inner lid (A.15)

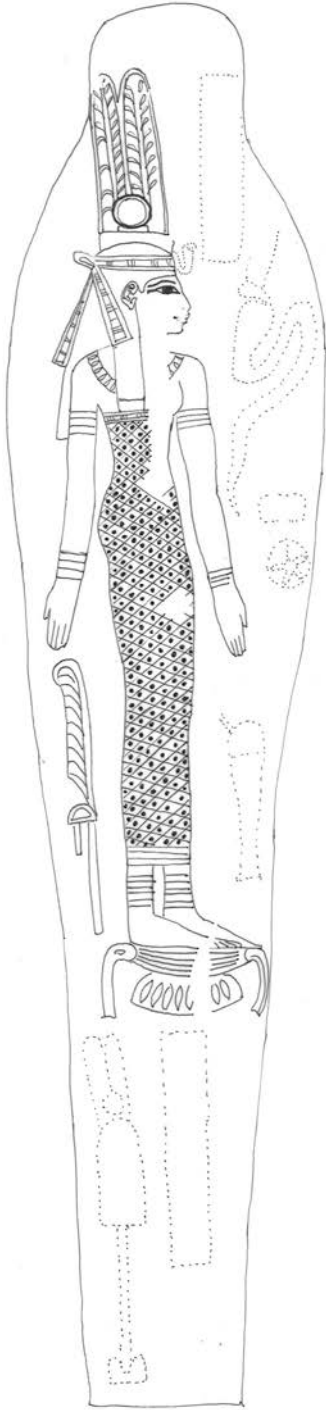

FIGURE 302
Inner case—interior decoration (A.60)



FIGURE 303
Outer lid (A.60)

Bibliography

- ASAE Annales du Service des Antiquités de l'Égypte
BIE Bulletin de l'Institut Égyptien
BO Bibliotheca Orientalis
CAA Corpus Antiquitatum Aegyptiarum
CG Catalogue Général des Antiquités Égyptiennes du Musée du Caire
JARCE Journal of the American Research Center in Egypt
JSA Journal of Social Archaeology
OBO Orbis Biblicus et Orientalis
OMRO Oudheidkundige Mededelingen mit het Rijksmuseum van Oudheden
RMVW Rocznik Museum Narodowego w Warszawie
ROM Rotunda—The Magazine of the Royal Ontario Museum
SAOC Studies in Ancient Oriental Civilization

- Allen, T. George. 1974. *The Book of the Dead or Going Forth by Day. Ideas of the Ancient Egyptians Concerning the Hereafter as Expressed in Their Own Terms*. SAOC vol. 37. Chicago: University of Chicago Press.
- Amenta, Alessia, Ulderico Santamaria, and Fabio Morresi. 2013. *Vatican Coffin Project: Protocol of the Analysis*. Città del Vaticano: Edizioni dei Musei Vaticani.
- Amenta, Alessia. 2014. "The Vatican Coffin Project". In *Thebes in the First Millennium*, eds. Elena Pischikova, Julia Budka and Kenneth Griffin. 483–502. Cambridge: Cambridge Scholars Publishing.
- Amenta, Alessia, and Héléne Guichard. eds. 2017. *Proceedings of the First Vatican Coffin Conference (Vatican Museums, 19–22 June 2013)*, Città del Vaticano: Edizioni Musei Vaticani.
- Aston, David. 1994. "The shabti box: a typological study". *OMRO* 74: 21–54.
- Aston, David. 2009. *Burial assemblages of Dynasty 21–25: chronology—typology—developments*. Contributions to the chronology of the Eastern Mediterranean 21; Österreichische Akademie der Wissenschaften, Denkschriften der Gesamtkademie 54. Wien: Verl. der Österr. Akad. der Wiss.
- Aubert, Liliane. 1998. *Les statuettes funéraires de la Deuxième Cachette à Deir el-Bahari. Avec les contributions de Jacques-F. Aubert, Jeanne Bulté, Jean Yoyotte*. Paris: Cybele 1998.
- Baines, John, and Peter Lacovara. 2002. "Burial and the Dead in Ancient Egyptian Society." *JSA* 2, no. 1: 5–36.
- Berlev, Oleg, and Svetlana Hodjash. 1998. *Catalogue of the monuments of Ancient Egypt: from the museums of the Russian Federation, Ukraine, Bielorrussia, Caucasus, Middle Asia and the Baltic States*. OBO, Series Archaeologica 17. Fribourg: University Press. Göttingen: Vandenhoeck & Ruprecht.

- Berman, Lawrence M., and Kenneth J. Bohac. 1999. *Catalogue of Egyptian art: the Cleveland Museum of Art*. New York: Hudson Hill Press.
- Bosticco, Sergio. 1958. *Esposizione di sarcofagi lignei restaurati. Seconda Settimana dei Musei Italiani, 23 Ottobre–1 Novembre 1958*. Soprintendenza delle antichità d'Etruria. Museo Archeologico—Sezione Egiziana. Firenze: Tipografia Giuntina.
- Botti, Giuseppe. 1955. *Le antichità egiziane del Museo dell'Accademia di Cortona ordinate e descritte*. Firenze, Leo S. Olschki = Atti dell'Accademia Toscana di Scienze e Lettere "La Colombaria". Firenze 19 (1954) and 20 (1955).
- Bresciani, Edda, M. Cristina Guidotti; Alessandro Menghini, Rita Pagiotti, and Flora Silvano. 2006. *La bellezza femminile nell'Antico Egitto*. Sansepolcro: Aboca Museum.
- Chappaz, Jean Luc. 1984. *Les figurines funéraires égyptiennes du Musée d'Art et d'Histoire et de quelques collections privées*. Aegyptiaca Helvetica 10. Genève: Éditions de Belles-Lettres.
- Chassinat, Émile. 1909. *Catalogue général des antiquités égyptiennes du Musée du Caire: La Seconde Trouvaille de Deir el-Bahri (sarcophages)*. Cairo, Leipzig: Institut Français d'Archéologie Orientale, Karl Hiersemann.
- Cooney, Kathlyn M. 2007. *The Cost of Death: The Social and Economic Value of Ancient Egyptian Funerary Art in the Ramesside Period*. Leiden: Egyptologische Uitgaven.
- Cooney, Kathlyn M. 2011. "Changing Burial Practices at the End of the New Kingdom: Defensive Adaptations in Tomb Commissions, Coffin Commissions, Coffin Decoration, and Mummification." *JARCE* 47: 3–44.
- Cooney, Kathlyn M. 2014. "Ancient Egyptian Funerary Arts as Social Documents: Social Place, Reuse, and Working Towards a New Typology of 21st Dynasty Coffins." In *Body, Cosmos, and Eternity: New Research Trends in the Iconography and Symbolism of Ancient Egyptian Coffins*, ed. Rogério Sousa. Archaeopress Egyptology 3, 45–66. Oxford: Archaeopress.
- Cooney, Kathlyn M. 2015. "Placating the Dead: Evidence of Social Crisis in Three Texts from Western Thebes." In *Joyful in Thebes: Egyptological Studies in Honor of Betsy M. Bryan*, eds. Richard Jasnow, Kathlyn M. Cooney and Katherine E. Davis, 79–90. Atlanta, Georgia: Lockwood Press.
- Cooney, Kathlyn M. 2017. "Ramesside Body Containers of Wood and Cartonnage from Northern Egyptian Necropolises." In *Festschrift for René Van Walsem*, ed. Vincent Vershoor. Leiden: Egyptologische Uitgaven, Netherlands Institute of the Near East.
- Cooney, Kathlyn M. 2018. "The End of New Kingdom Egypt: How Ancient Egyptian Funerary Materials Can Help Us Understand Society in Crisis." In *The Ramesside Period in Egypt: Studies into Cultural and Historical Processes of the 19th and 20th Dynasties, Proceedings of the International Symposium Held at Heidelberg, 5th to 7th June, 2015*, eds. S. Kubisch / U. Rummel (eds.), SDAIK 41. Berlin: Verlag Walter de Gruyter.

- Daressy, Georges. 1902. "Procès-verbal d'ouverture de la momie no. 29707". *ASAE* 3, 151–154.
- Daressy, Georges. 1907. "Les cercueils des prêtres d'Ammon (Deuxième Trouvaille de Deir el-Bahari)". *ASAE* 8, 3–38.
- Daressy, Georges. 1903. "Ouverture des momies provenant de la Seconde Trouvaille de Deir el-Bahari", *ASAE* 4, 150–155.
- Daressy, Georges, and Elliot G. Smith. 1903. "Ouverture des momies provenant de la Seconde Trouvaille de Deir el-Bahari". *ASAE* 4, 150–160.
- Dautant, Alain, France Jamen, and Escobar Claros. 2013. *Distribution and current location of the French lot from the Bab el-Gasus cache*. In *Proceedings of the First Vatican Coffin Conference, 19–22 June 2013* (Vol. 1), eds Alessia Amenta, Hélène Guichard, 123–128. Vatican: Edizioni Musei Vaticani.
- Dawson, Julie, Jennifer Marchant, Eleanor von Aderkas, et alli. 2016. "Egyptian coffins: Materials, construction and decoration". In *Death on the Nile: Uncovering the After-life of Ancient Egypt*, eds Helen Strudwick, Julie Dawson, 75–113. Cambridge: The Fitzwilliam Museum.
- De Araújo, Luis Manuel. 2003. *Estatuetas funerárias egípcias da XXI dinastia*. Lisboa: Fundação Calouste Gulbenkian; Fundação para a Ciência e a Tecnologia.
- De Araújo Duarte, Cássio. 2014. "Crossing the landscapes of eternity: parallels between Amduat and funeral procession scenes on the 21st Dynasty coffins". In *Body, Cosmos and Eternity: New research trends in the iconography and symbolism of ancient Egyptian coffins*, ed. Rogério Sousa. *Archaeopress Egyptology* 3, 81–90. Oxford: Archaeopress.
- De Araújo Duarte, Cássio. 2014. 'The Amduat on the 21st Dynasty coffins'. In *Proceedings of the First Vatican Coffin Conference, 19–22 June 2013* (Vol. 1), eds Alessia Amenta, Hélène Guichard, 137–144. Vatican: Edizioni Musei Vaticani.
- Dodson, Aidan. 2015. *Ancient Egyptian Coffins: The Medelhavsmuseet Collection*. Stockholm: Världskulturmuseerna.
- Dawson, W.R., and P.H.K. Gray. 1968. *Catalogue of Egyptian Antiquities in the British Museum: Mummies and Human Remains 1*. London.
- Delvaux, Luc, and Isabelle Therasse. 2015. *Sarcophages. Sous les Étoiles de Nout*. Bruxelles: Musées royaux d'Art et d'Histoire.
- El-Shaṭer. 1987. "Compiling a geographical index: first report". *ASAE* 66, 243–266.
- Extrait. 1981. "Extrait de l'Inventaire du Musée de Ghizeh comprenant les objets entrés dans les collections du 1er Janvier au 31 Decembre 1891". *BIE* 2, 325–375.
- Fabretti, A., F. Rossi, and R. Lanzone. 1882. *Regio Museo Di Torino: Antichità Egizie*. Turin.
- Gabolde, Marc. 1990. *Catalogue des antiquités égyptiennes du Musée Joseph Déchelette*. Roanne: Musée Joseph Déchelette.
- Gardiner, Alan H. 1999. *Egyptian Grammar (3rd edition, revised)*. Oxford, Ashmolean Museum, Griffith Institute (First published 1927).

- Gasse, Annie. 1996. *Les sarcophages de la Troisième Période Intermédiaire du Museo Gregoriano Egizio*. Città del Vaticano: Vatican Museums.
- Guidotti, M. Cristina, ed. 2000. *Mal d'Egitto: origini del gusto e passione scientifica nella Toscana dell'800*. Livorno: Sillabe.
- Guidotti, M. Cristina, ed. 2009. *I tessuti del Museo Egizio di Firenze*. Firenze: Giunti Editore.
- Guidotti, M. Cristina. 2015. "Da Rosellini a Schiaparelli: Reperti botanici nel Museo Egizio di Firenze", in *Naturalia e artificialia i, le piante e i fiori d'Egitto nell'esperienza museografica degli scavi e degli erbari*, ed. Aldo Actis Caporale and Elvira D'Amicone, 121–128. Publicacions de l'Abadia de Montserrat: Impresion ofset Derra-Llull Barcelona.
- Haarlem, Willem. 1886. *Allard Pierson Museum, Amsterdam, fascicle 1: selection from the collection*. CAA. Lose-Blatt-Katalog ägyptischer Altertümer. Mainz/Rhein: Philipp von Zabern.
- Haarlem, Willem. 1990. *Allard Pierson Museum, Amsterdam, fascicle 2: shabtis*. CAA. Lose-Blatt-Katalog ägyptischer Altertümer. Amsterdam: Allard Pierson Museum.
- Haslauer, Elfriede. 1992. *Kunsthistorisches Museum Wien, Ägyptisch-Orientalische Sammlung, Lieferung 8: Uschebti 2*. CAA. Lose-Blatt-Katalog ägyptischer Altertümer. Mainz/Rhein: Philipp von Zabern.
- Hornung, Erik. 1999. *The Ancient Egyptian Books of the Afterlife*. Ithaca, London: Cornell University Press.
- Janes, Glenn. 2002. *Shabtis: a private view. Ancient Egyptian funerary statuettes in European private collections*. Photographs by Tom Bangbala. Paris, Cybèle.
- Küffer, Alexandra. 2017. "The coffins from the cache-tomb of Bab el-Gasus in Switzerland". In *Proceedings of the First Vatican Coffin Conference, 19–22 June 2013* (Vol. 1), eds. A. Amenta, H. Guichard, 249–254. Vatican: Edizioni Musei Vaticani.
- Küffer, Alexandra, and Renate Siegman. 2007. *Unter dem Schutz der Himmelsgöttin: Ägyptische Särge, Mumien und Masken in der Schweiz*. Zürich: Chronos.
- Lacovara, Peter, and Haynes, Joyce. 2018. "Ankhefenmut and his world". In *The mystery of the Albany mummies*, eds. Peter Lacovara and Sue D'Auria. Albany: Excelsior Editions.
- Lewin, Peter; A.J. Mills, Howard Savage, and John Vollmer. 1974. "Nakht: A Weaver of Thebes." *ROM* 7, no. 4: 15–19.
- Liptay, Éva. 2011. *Coffins and coffin fragments of the Third Intermediate Period (I). Catalogues of the Egyptian Collection*. Budapest: Museum of Fine Arts.
- Liptay, Éva. 2014. "Representations of passage in ancient Egyptian iconography". In *Body, Cosmos and Eternity: New research trends in the iconography and symbolism of ancient Egyptian coffins*, ed. Rogério Sousa. *Archaeopress Egyptology* 3, 67–80. Oxford: Archaeopress.
- Liptay, Éva. 2017. "The ancient Egyptian coffin as sacred space: Changes of the sacred

- space during the Third Intermediate Period". In *Proceedings of the First Vatican Coffin Conference, 19–22 June 2013* (Vol. 1), eds. Alessia Amenta, H el ene Guichard, 259–270. Vatican: Edizioni Musei Vaticani.
- Maclean, J.P. 1901. *The Archaeological Collection of the Western Reserve Historical Society*. Cleveland: Western Reserve Historical Society.
- Mann, Liliane, Christian Greco, and Lara Weiss. 2018. "The Coffins in Leiden". *The Coffins of the Priests of Amun: Egyptian coffins from the 21st Dynasty in the collection of the National Museum of Antiquities in Leiden*, eds. Lara Weiss. Papers on Archaeology of the Leiden Museum of Antiquities (vol. 17), 35–48. Leiden: Rijksmuseum van Oudheden.
- Manley, Bill, and Aidan Dodson. 2010. *Life Everlasting: National Museums Scotland Collection of Ancient Egyptian Coffins*. Edinburgh: National Museums Scotland.
- Marini, Paolo. 2012. "I contenitori di ushabti dei Musei italiani", *Egitto e Vicino Oriente* 35: 83–124.
- Mogensen, Maria. 1918. *Inscriptions hi eroglyphiques du Mus e National de Copenhague*. Copenhagen: H ost.
- Naguib, Saphinaz A. 1985. *Etnografisk Museum, Oslo, fascicle 1: Funerary statuettes*. CAA. Lose-Blatt-Katalog  gyptischer Altert umer. Mainz/Rhein: Philipp von Zabern.
- N aser, Claudia. 2002. "Der Alltag Des Todes. Archaeologische Zeugnisse Und Textquellen Zu Funer ren Praktiken Und Grabpl nderung in Deir El-Medine Im Neuen Reich". Berlin: Humboldt-Universit t zu Berlin.
- N aser, Claudia. 2008. "Jensites Fon Theben—Objectsammlung, Inszenierung Und Fragmentierung in  gyptischen Bestattungen Des Neuen Reiches." In *K rperinszenierung—Objectsammlung—Monumentalisierung: Totenritual Und Grabkult in Fr hen Gesellschaften*, edited by Beat Schweizer Christoph K ummel, Ulrich Veit. Arch ologische Quellen in Kulturwissenschaftlicher Perspektive, 445–472. M nster Waxman.
- Newberry, Percy E. 1957. *Funerary Statuettes and Model Sarcophagi. Troisi me fascicule (Indices et planches)*. Le Caire, Imprimerie de l'Institut fran ais d'Arch ologie orientale = CG N  46530–48575. Service des Antiquit s de l' gypte.
- Niwi nski, Andrzej. 1988. *Twenty-First Dynasty Coffins from Thebes: Chronological and typological studies*. Theben 5. Mainz: Zabern.
- Niwi nski, Andrzej. 1989. *Studies on the illustrated Theban funerary papyri of the nth and 10th centuries B.C.*—Universit tsverlag Freiburg, Schweiz; Vandenhoeck und Ruprecht Gottingen, 1989. OBO 86.
- Niwi nski, Andrzej. 2004. (con appendici de Gian Luigi Nicola, Thierry Radelet e Giuseppe Laquale), *Sarcophagi della XXI Dinastia (CGT 10101–10122)*. Torino: Ministero per i Beni e le Attivit  Culturali—Soprintendenza al Museo delle Antichit  Egizie.
- Peet, T.E. 1930. *The Great Tomb-Robberies of the Twentieth Egyptian Dynasty, Being a Critical Study with Translations and Commentaries of the Papyri in Which They Are Recorded* (2 vols). Oxford: Clarendon Press.

- Pellegrini, Astorre. 1899. "Statuette funerarie del Museo Archeologico di Firenze". *Bessarione* VII (1899–1900), 1–32 e 248–269.
- Petrie, W.M. Flinders 1935. *Shabtis: illustrated by the Egyptian collection in University College, London, with catalogue of figures from many other sources*. British School of Archaeology in Egypt and Egyptian Research Account [57] (41st year). London: British School of Egyptian Archaeology. B. Quaritch.
- Piankoff, Alexandre. 1957. *Mythological papyri* (2 vols). Egyptian Religious Texts and Representations 3; Bollingen Series 40 (3). New York: Pantheon Books for the Bollingen Foundation.
- Pomorska, Irena. 1959. "Uszebti w zbiorach Polskich Muzeum Narodowego w Warszawie Muzeum Narodowego (Zbiory Czartoryskich w Krakowie) i Dawney kolekcji Goluchowskiej". *RMVW* 4, 93–175.
- Porter, Bertha, and Rosalind Moss. 1960. *Topographical bibliography of ancient Egyptian hieroglyphic texts, reliefs, and paintings. Vol. 1: 1. The Theban necropolis Part 1. Private tombs*. Oxford: Griffith Institute, Ashmolean Museum.
- Reeves, Nicholas. 1990. *Valley of the Kings. The Decline of a Royal Necropolis*. London: Kegan Paul International.
- Roccati, Alessandro, and Giuseppina Capriotti Vitozzi, eds. 2002. *Tra le palme del Piceno. Egitto, Terra del Nilo*. Poggibonsi (Siena): Arti Grafiche Nencini.
- Roeder, Gunther. 1913. *Ägyptische Inschriften aus den Königlichen Museen zu Berlin*. 2 vols. Leipzig: Hinrichs.
- Rosati, Gloria. 1985. "Antichità egizie ad Assisi". *Oriens Antiquus* 24, 55–65.
- Saleh Ali, Mohamed, ed. 1999. *Arte sublime nell'Antico Egitto*. Firenze-Milano: Artificio Skira.
- Sandman, Maj. 1931. "Les statuettes funéraires du musée de Victoria à Uppsala". *Sphinx* 22, 93–108.
- Schiaparelli, Ernesto. 1887. *Il Museo Archeologico di Firenze—Antichità Egizie*. Roma: Tipografia della R. Accademia dei Lincei.
- Schlögl, Hermann A., and Andreas Brodbeck. 1990. *Ägyptische Totenfiguren aus öffentlichen und privaten Sammlungen der Schweiz*. OBO Series Archaeologica 7. Freiburg (Schweiz); Göttingen: Universitätsverlag; Vandenhoeck & Ruprecht.
- Schneider, Hans D. 1977. *Shabtis. An Introduction to the History of Ancient Egyptian Funerary Statuettes with a Catalogue of the Collection of Shabtis in the National Museum of Antiquities at Leiden* (3 Vols). Leiden, Rijksmuseum van Oudheden.
- Seipel, Wilfried. 1989. *Ägypten: Götter, Gräber und die Kunst. 4000 Jahre Jenseitsglaube* (2 vols). Kataloge des Öö. Landesmuseums, Neue Folge 22 (1/2). Linz: Oberösterreichisches Landesmuseum.
- Silvano, Flora. 1980. "Le reticelle funerarie nell'Antico Egitto: proposte di interpretazione". In *EVO* 3, 83–97.
- Sousa, Rogério. 2007. "The meaning of the heart amulets in Egyptian Art". *JARCE* 43: 59–70.

- Sousa, Rogério. 2011. *The Heart of Wisdom: Studies on the Heart Amulet in Ancient Egypt* (1S 2211). Oxford: British Archaeological Reports.
- Sousa, Rogério. 2014. "Spread your wings over me: Iconography, Symbolism and Meaning of the Central Panel on Yellow Coffins". In *Body, Cosmos, and Eternity: New Research Trends in the Iconography and Symbolism of Ancient Egyptian Coffins*, ed. Rogério Sousa. Archaeopress Egyptology 3, 197–203. Oxford: Archaeopress.
- Sousa, Rogério. 2017a. *Burial assemblages from Bab el-Gasus in the Geographical Society of Lisbon*. Monumenta Aegyptiaca, vol. xvii. Turnhout: Brepols.
- Sousa, Rogério. 2017b. "Building catalogues. The concept of 'architectonisation' and the description of coffins of the 21st Dynasty". In *Proceedings of the First Vatican Coffin Conference, 19–22 June 2013* (Vol. 1), eds. Alessia Amenta, Hélène Guichard, 515–520. Vatican: Edizioni Musei Vaticani.
- Sousa, Rogério. 2018a. "The Tomb of the Priests of Amun in Thebes: The History of the Find". In Lara Weiss (edt), In *The Coffins of the Priests of Amun: Egyptian coffins from the 21st Dynasty in the collection of the National Museum of Antiquities in Leiden*, ed. Lara Weiss. Papers on Archaeology of the Leiden Museum of Antiquities (Vol. 17), 21–34. Leiden: Rijksmuseum van Oudheden.
- Sousa, Rogério. 2018b. *Gleaming Coffins: Iconography and Symbolism in Theban Coffin Decoration (21st Dynasty)*—The Sheltering Sky (Vol. 1). Coimbra: Coimbra University Press.
- Sousa, Rogério, and Vinnie Nørskov. Forthcoming. 'Tabasety, the Temple Singer in Aarhus'.
- Strudwick, Helen, and Julie Dawson. Eds. 2016. *Death on the Nile: Uncovering the Afterlife of Ancient Egypt*. London: D. Giles Limited.
- Tarasenko, Mykola. 2017. "The Third Intermediate Period coffins in the Museums of Ukraine". In *Proceedings of the First Vatican Coffin Conference, 19–22 June 2013* (Vol. 1), eds. Alessia Amenta, Hélène Guichard, 529–540. Vatican: Edizioni Musei Vaticani.
- Taylor, John. 1992. "Aspects of the History of the Valley of the Kings in the Third Intermediate Period." In *After Tut'Ankhamun. Research and Excavation in the Royal Necropolis at Thebes*, edited by Nicholas Reeves. London: Kegan Paul International.
- Taylor, John. 2010. "The landscape of the hereafter". In *Journey through the afterlife*, ed. John Taylor, 132–140. Cambridge, Massachusetts: Harvard University Press.
- Taylor, John. 2016. "Coffins from the New Kingdom to the Roman Period". In *Death on the Nile: Uncovering the Afterlife of Ancient Egypt*, eds. Helen Strudwick, Julie Dawson, 49–75. Cambridge: The Fitzwilliam Museum.
- Van Walsem, René. 1993. "The Study of 21st Dynasty Coffins from Thebes." *BO* 50: 9–92.
- Van Walsem, René. 1997. *The coffin of Djedmonthuiufankh in the National Museum of Antiquities at Leiden*. Vol. 1: Technical and Iconographic/Iconological aspects. Egyptologische uitgaven (Vol. 10). Leiden: Nederlands Instituut Boor Het Nabije Oosten.

Van Walsem, René. 2014a. "From skin wrappings to architecture: The evolution of pre-historic, anthropoid wrappings to historic architectonic coffins/sarcophagi; separate contrasts optimally fused in single Theban 'stola' coffins (c. 975–920 BC)". In *Body, Cosmos, and Eternity: New Research Trends in the Iconography and Symbolism of Ancient Egyptian Coffins*, edited by Rogério Sousa. *Archaeopress Egyptology* 3, 1–28. Oxford: Archaeopress.

Index

Names of Deities

- Abdu-fish 47, 48
- Amun 130, 152, 195, 201, 299, 326, 334, 335, 337, 340, 341, 344, 348, 351, 356, 359, 365, 367, 372, 375, 378, 386, 390, 391, 394, 396, 397, 400, 403, 406, 409, 412, 415, 418, 419, 423, 429, 432, 443, 450, 453, 459, 462, 482, 485, 487, 489, 490, 491, 509, 510, 515, 526, 532, 538, 539
- Amun-Re 73, 91, 108, 114, 131, 157, 158, 314, 329, 338, 386, 400, 435, 437, 440, 459, 472, 475
- Anubis (Anupu) 48, 50, 91, 145, 155, 172, 253, 255, 256, 299, 530
- Apopis 45, 49, 527, 528n45
- Aten 218, 219
- Atum 218, 219
- Duamutef 159, 188, 278
- Ennead 48, 49, 50, 51, 91, 129, 130, 131, 174, 175, 219, 297, 298, 299
- Geb 29, 73, 88, 173, 279, 526, 527
- Great Devourer 173, 216, 296
- Hapy 154, 155, 159, 278, 280, 423
- Hathor 44, 128, 130, 172, 419, 526, 528n45, 531
- Hereret 172
- Horus 29, 30, 73, 173, 279, 450
- Imseti 158, 278
- Inet-fish 47, 48
- Isis 29, 31, 48, 73, 119, 155, 158, 172, 174, 175, 176, 188, 199, 201, 213, 214, 215, 216, 219, 221, 239, 254, 255, 260, 261, 279, 280, 526
- Kepri 259
- Khefthernebes 49, 298
- Khonsu 365, 378, 394, 419, 429, 459
- Ma'at 42, 43, 48, 49, 50, 51, 129, 131, 172, 174, 175, 176, 294, 295, 296, 297, 298
- Mehen 526, 529
- Merety 130, 131
- Mourning goddess 28, 72, 155, 157, 518
- Mut 173, 335, 338, 340, 341, 351, 356, 359, 365, 378, 397, 415, 419, 423, 429, 437, 440, 443, 472
- Neith 44, 71, 72, 87, 88, 90, 107, 117, 154, 155, 157, 172, 173, 186, 187, 199, 216, 255, 277, 280, 294, 313, 527
- Nekhbeth 443
- Nephtys 31, 47, 87, 119, 155, 157, 159, 160, 215, 220, 242, 281, 296
- Nut 29, 30, 73, 87, 88, 108, 117, 129, 132, 155, 173, 186, 279, 298, 314, 526, 527
- Osiris 26, 28, 30, 44, 47, 48, 51, 71, 72, 73, 88, 91, 107, 108, 114, 117, 118, 119, 127, 128, 130, 131, 145, 154, 155, 156, 157, 158, 159, 172, 173, 174, 175, 176, 187, 188, 198, 199, 200, 201, 202, 213, 215, 218, 219, 220, 221, 239, 241, 253, 254, 255, 256, 258, 259, 260, 261, 280, 295, 297, 299, 313, 314, 315, 326, 328, 329, 331, 334, 337, 340, 343, 344, 347, 348, 350, 351, 355, 356, 358, 359, 361, 364, 367, 371, 372, 377, 378, 380, 383, 386, 387, 390, 391, 393, 394, 396, 397, 399, 400, 402, 405, 406, 408, 411, 412, 414, 415, 418, 423, 425, 428, 429, 431, 434, 435, 436, 439, 442, 446, 449, 452, 455, 458, 459, 461, 462, 464, 465, 471, 472, 475, 516, 518, 520, 523, 524, 525, 526, 528, 528n45, 529, 530, 531, 532, 538
- Ptah-Sokar 48, 50, 51, 91, 117, 119, 127, 144, 153, 156, 185, 186, 187, 278, 293, 296, 313, 516, 518, 520, 528, 529
- Ptah-Sokar-Osiris 129, 156, 297, 298
- Qebhsenuf 278
- Re 29, 30, 31, 43, 48, 49, 50, 73, 129, 131, 132, 155, 157, 158, 159, 160, 172, 174, 175, 176, 188, 201, 214, 215, 219, 220, 221, 254, 256, 260, 261, 279, 280, 281, 297, 298, 453

Re-Atum 91
 Re-Atum-Khepry 49, 131, 297, 299, 525, 529
 Re-Horakhty-Atum 201, 202, 218, 241, 242,
 255, 259, 530
 Seth 419
 Shayt 296
 Shu 87, 88, 173, 526
 Sobek 368
 Sokar 280, 315

Animal and Composite Deities

Baboon-headed god 28, 46, 72, 89, 217, 258,
 294, 295
 Bull 46, 86, 87, 89
 Bull-headed god 89
 Cat-headed god 257, 258
 Cobra 26, 27, 28, 42, 43, 44, 46, 71, 72, 85,
 86, 87, 88, 90, 107, 108, 117, 127, 128, 153,
 154, 155, 156, 171, 172, 173, 174, 185, 186,
 187, 199, 213, 215, 239, 240, 254, 256, 258,
 277, 278, 294, 295, 313, 368, 522, 527
 Cobra-headed god 217, 528
 Cow 44, 87, 128, 172, 215, 256, 526, 530
 Crocodile-headed god 88
 Donkey-headed god 27, 47
 Falcon 26, 27, 44, 86, 87, 88, 89, 154, 173, 174,
 185, 199, 217, 239, 240, 254, 258, 278,
 294, 295, 397, 423, 450, 516, 522
 Falcon-headed god 28, 43, 44, 89, 90, 156,
 173, 214, 217, 254, 257, 294, 295, 296, 378
 Frog 198, 277, 519
 Goat-headed god 89
 Hare-headed god 86, 257, 258
 Hippopotamus 216
 Hippopotamus-headed god 88, 108, 173, 257
 Ibis-headed god 278
 Jackal 155, 172, 253
 Jackal-headed god 44, 45, 89, 128, 129, 156,
 174, 198, 214, 215, 217, 294, 296

Sons of Horus 114, 278, 351, 368, 400, 403,
 415, 429, 450, 471, 524
 Thoth 43, 44, 49, 50, 127, 128, 129, 131, 171,
 172, 173, 174, 175, 176, 294, 295, 297, 298,
 526, 528, 529
 Unnefer 29, 73, 158, 187, 220, 259, 279
 Wadjet 44

Lion 46, 127, 257, 529
 Lion-headed god 45, 89, 128, 129, 187, 217,
 294, 296
 Ouroboros 47, 90
 Panther 46, 529
 Ram 278
 Ram-headed god 45, 117, 128, 154, 173, 186,
 187, 294, 295
 Scarab 26, 28, 43, 45, 71, 85, 86, 107, 117, 128,
 144, 155, 173, 198, 239, 277, 294, 295,
 313, 329, 341, 344, 348, 351, 356, 368,
 372, 378, 387, 391, 397, 400, 403, 412,
 423, 426, 450, 459, 489, 520, 522, 524,
 526
 Sethian animal 89
 Shrew-headed god 89, 256
 Snake (or serpent) 43, 45, 46, 49, 85, 90, 129,
 171, 295
 Snake-headed deity 42, 43, 44, 45, 46, 72,
 88, 89, 90, 214, 215, 216, 217, 240, 257,
 258
 Snake (Double)-headed god 257
 Stork 46, 529
 Turtle 49, 50, 129, 131, 174, 175, 297, 298
 Vulture 27, 28, 44, 47, 71, 88, 89, 90, 107, 215,
 217, 239, 240, 258, 295, 527
 Vulture-headed god 89, 214, 216, 217, 257

Sacred Topography and Cosmological References

- Abydos 73, 88, 130, 154, 158, 187, 200, 218,
261, 297
Akhet 43, 45
Busiris (Djedu) 48, 218
Cavern 48
Duat 30, 44, 45, 46, 47, 48, 51, 71, 72, 73, 85,
86, 87, 90, 91, 118, 119, 128, 129, 130, 131,
214, 217, 220, 221, 241, 254, 256, 257, 260,
261, 296, 365, 387, 453
Earth 51, 73, 91, 118, 219, 298, 365, 387, 453
East 91, 128, 217
Field of Reeds 51, 218
Firmament 48, 118, 314
Flame-headed god 257
Great temple 30
Hall of the Double Ma'at 48
Heliopolis/Heliopolitan 201, 202, 218, 241,
255, 259
Hierakonpolis 443
House of Embalming 47, 48, 145, 157, 159,
160, 172, 176, 242, 254, 260, 261, 280
House of Life 175, 188, 220
Igeret 51, 91
Imperishable Stars 30, 74, 108, 314
Isheru 378
Karnak 365, 387, 391, 443, 453
Manu Mountain 49, 50, 529
Mountain 48, 130, 172
Necropolis 49, 130, 131, 217, 299, 525
North 91
Nubet 218
Sacred Land 30, 48, 49, 50, 91, 130, 145, 218,
220, 221
Sky 45, 48, 49, 73, 91, 118, 131, 219, 297, 299,
314, 356, 365, 387, 453
Solar disk (or sun) 26, 27, 28, 43, 45, 46, 48,
51, 71, 72, 85, 87, 88, 90, 107, 108, 117, 144,
154, 155, 173, 186, 198, 199, 214, 239, 240,
241, 254, 277, 278, 313, 527, 529
South 91
Theban Mountain 44, 87, 215, 256, 295
Thebes 72, 108, 131, 219, 365, 492, 493, 504,
531
Tjam (Djeme) 218
Two Banks 132, 279, 298
Two Lands 201, 202, 218, 241, 242, 255, 259
Unweary Stars 30, 74, 108, 314
West 26, 44, 45, 50, 73, 74, 88, 91, 127, 128,
129, 130, 155, 157, 158, 159, 171, 172, 173,
174, 200, 213, 214, 215, 217, 218, 219, 220,
239, 253, 254, 255, 256, 257, 259, 296,
297, 525, 529

Ritual Objects

- Atef*-crown 28, 43, 86, 89, 90, 108, 117, 127,
144, 153, 154, 155, 156, 157, 173, 174,
185, 186, 187, 216, 254, 258, 278, 293,
313
Barque 43, 45, 48, 51, 85, 86, 118, 128, 201,
255, 259, 294, 295, 314, 356, 527
Double-crown 173, 296
Dšrt-crown 86, 117, 277, 294
Imi-wt-totem 28, 42, 43, 44, 45, 46, 86, 88,
156, 172, 173, 198, 199, 200, 214, 216, 240,
253, 254, 256, 294, 295, 296
Heart amulet 88, 372, 387, 429, 521, 522,
527
Hedjet-crown 26, 46, 71, 85, 86, 87, 88, 107,
117, 127, 156, 198, 199, 214, 215, 239, 240,
241, 254, 255, 256, 277, 278, 293, 294,
295, 296, 313

Hedjet-mace 156
Hememet-crown 46
Heqa-scepter 27, 117, 214, 215, 241, 254, 255, 256
Hwt-throne 26, 107, 213, 215, 278, 295, 296, 313
 Lotus scepter 239
Menat-counterpoise 72, 86, 87, 108, 117, 215, 240, 253, 254, 293, 313
Nekhakha-scepter 46, 47, 90, 144, 172, 186, 214, 215, 254, 255, 256

Hieroglyphic Signs

Akh 29, 47, 48, 73, 118, 128, 130, 145, 279, 297, 299
Ankh-sign 43, 44, 47, 72, 90, 108, 117, 214, 215, 216, 217, 240, 254, 255, 256, 258, 295, 313, 501
Ba 27, 30, 43, 44, 46, 48, 49, 50, 71, 72, 87, 88, 90, 107, 108, 129, 131, 155, 172, 173, 174, 218, 219, 256, 257, 277, 280, 294, 297, 299, 314, 315, 518, 519, 520, 521, 527, 529
Djed 46, 86, 156, 157, 186, 240, 277, 278, 529
Heb-bowl 27, 28, 43, 44, 45, 47, 72, 86, 87, 88, 89, 90, 108, 117, 128, 144, 155, 156, 186, 187, 215, 256, 257, 258, 278, 295, 313
Ka 128
Neb-basket 85, 117, 144, 154, 156, 186, 198, 239
Nebu-sign 26, 27, 42, 44, 46, 72, 90, 154, 156, 157, 186, 198, 199, 217, 239, 240, 296, 313, 522

Royal scepters 26, 27, 43, 44, 45, 71, 72, 86, 88, 107, 154, 156, 173, 198, 213, 214, 215, 239, 258, 277, 278, 296, 313
Sekhem-scepter 43, 86, 155, 214, 255, 278
Seshed-headband 46, 90, 258, 358, 386, 390, 393, 402, 408, 414, 418, 439, 449, 455, 458, 461
Shetyt-shrine 27, 28, 44, 45, 48, 50, 51, 91, 198, 214, 216, 217, 218, 239, 240, 297, 298, 522
 Sistrum 44, 128, 295
Ta-wer-totem 27, 28, 88, 128, 198, 213, 216, 239, 253, 254, 277, 294, 531

Nefer-sign 26, 27, 46, 87, 128, 186, 253, 278, 471
Pet-sign 43, 44, 45, 46, 85, 86, 89, 90, 144, 154, 155, 186, 217, 239, 257, 258, 277, 294, 295
Sema-tawy 26, 155, 156, 172, 173
Shemsu-sign 45
Shen-ring 26, 28, 43, 44, 71, 87, 107, 117, 128, 153, 155, 157, 172, 186, 213, 215, 239, 255, 258, 294
Tjet-sign 26, 42, 71, 107, 127, 171, 198, 199, 213, 253, 524
Udjat-eye 26, 27, 28, 46, 72, 85, 87, 107, 108, 117, 119, 127, 128, 143, 144, 153, 154, 155, 156, 157, 172, 173, 174, 185, 186, 187, 198, 215, 216, 240, 253, 277, 278, 293, 294, 295, 313, 314, 315, 471, 489, 521, 529
Wadjet-scepter 216
Was-sign 43, 107, 157, 172, 186, 199, 214, 241