

Germán Toro Pérez & Lucas Bennett (Eds)

The Performance Practice of Electroacoustic Music

The Studio di Fonologia years

ZÜRCHER MUSIKSTUDIEN



PETER LANG

Germán Toro Pérez & Lucas Bennett (Eds)

The Performance Practice of Electroacoustic Music

This book is dedicated to the topic of performance of electroacoustic music, focusing mainly on the production of RAI's Studio di Fonologia in Milan between the 1950s and 1970s. It is the result of an in-depth dialogue between musicology and musical practice, presenting musicological and practice-based contributions, some dealing with specific problems of performance practice, in particular the analysis and interpretation of the aesthetic prerequisites and production conditions of the repertoire from a musicological perspective, others focusing on specific works and on their realisation from a performer's perspective. Overall, this publication is intended as a contribution to the performance culture of the repertoire.

Germán Toro Pérez studied composition and electroacoustic music. His catalogue includes instrumental, electroacoustic and mixed compositions, music theater and works in collaboration with graphic design, painting and experimental video. Since 2007 he is director of the Institute for Computer Music and Sound Technology and professor for composition at the Zurich University of the Arts.

THE PERFORMANCE PRACTICE OF ELECTROACOUSTIC MUSIC

ZÜRCHER MUSIKSTUDIEN

Band 10

Herausgegeben von
Dominik Sackmann



PETER LANG

Bern · Berlin · Bruxelles · New York · Oxford · Warszawa · Wien

GERMÁN TORO PÉREZ,
LUCAS BENNETT (EDS)

THE PERFORMANCE PRACTICE OF ELECTROACOUSTIC MUSIC

The Studio di Fonologia years



PETER LANG

Bern • Berlin • Bruxelles • New York • Oxford • Warszawa • Wien

Bibliographic information published by die Deutsche Nationalbibliothek

Die Deutsche Nationalbibliothek lists this publication in the Deutsche Nationalbibliografie; detailed bibliographic data is available on the Internet at <http://dnb.d-nb.de>.

British Library Cataloguing-in-Publication Data: A catalogue record for this book is available from The British Library, Great Britain

Library of Congress Control Number: 2018933133

ISSN 1660-8739 pb.

ISBN 978-3-0343-3118-0 pb.

ISBN 978-3-0343-3120-3 EPUB

DOI 10.3726/11668

ISSN 2235-5790 eBook

ISBN 978-3-0343-3119-7 eBook

ISBN 978-3-0343-3121-0 MOBI

PETER LANG



Open Access: This work is licensed under a Creative Commons Attribution CC-BY 4.0 license. To view a copy of this license, visit <https://creativecommons.org/licenses/by/4.0/>

This publication has been peer reviewed.

© GERMÁN TORO PÉREZ, LUCAS BENNETT (EDS), 2018

Peter Lang AG

International Academic Publishers

Bern

Contents

GERMÁN TORO PÉREZ

Historically informed performance in electroacoustic music?
The Studio di Fonologia years as a case study 7

ULRICH MOSCH

Some problems of the present-day realisation of historical electronic pieces 19

ANGELA IDA DE BENEDICTIS

The beginnings of the Studio di Fonologia Musicale
and Bruno Maderna's *Notturmo* 25

VENIERO RIZZARDI

«There's always only the first page». On the ambivalent relation between
sound and notation in some early electroacoustic music, and the problems
of modern editions 43

PASCAL DECROUPET

A question of «versions»? Three case studies about «performing» tape
compositions of the 1950s (taken from the European repertoire)..... 63

KILIAN SCHWOON

The revision of Henri Pousseur's *Rimes* at Tempo Reale 87

GERMÁN TORO PÉREZ

Auctorial Tradition and Contemporary Practice:
Performing *Musica su due dimensioni* by Bruno Maderna 93

ALVISE VIDOLIN

Sound direction of 1950s and 1960s tape pieces from the Studio di Fonologia 113

PASCAL DECROUPET (Transcription and text edition)
Henri Pousseur. Three source texts concerning *Rimes pour
différentes sources sonores*..... 137

About the authors..... 149

Register 153

Historically informed performance in electroacoustic music? The Studio di Fonologia years as a case study

After more than 60 years, the term *performance practice* in the context of electroacoustic music seems to be established in professional circles.¹ However, the notion of the interpretation of electroacoustic music, at least of its purely electronic, non-instrumental parts, is not self-evident for experienced audiences and even for professional musicians who are not familiar with the repertoire. It is still not generally understood that this activity requires not only technological, but also musical knowledge, as well as specific performative abilities and artistic sensitivity. The practice, however, must also be further developed and consolidated inwardly. Performers have to become aware of the complexity of their task and create the conditions necessary to realise artistically valid performances.

As there is no consolidated performance culture today, it is a common occurrence for electroacoustic works to be performed without taking into account their musical and structural properties, their historical context or possible performance traditions, or for them to be realised with inadequate or technically faulty material. In some cases, this may be due to the often incomplete documentation or difficult access to unambiguous performance material. In any case, the impermanence of technical setups, and this includes all support types and instruments, adds to the difficulty of establishing favourable conditions for adequate performances. This problem is obviously more acute when dealing with works by composers of past generations. However, even the performance of works by living composers can present great challenges to performers, especially when they require specific setups or when they are inadequately documented.

1 The term *electroacoustic* is used here as a general term denoting a multitude of historically and aesthetically conditioned cultures of electronic music within which in the course of time, different forms of concert practice have evolved. It includes purely electroacoustic works stored on fixed media, as well as works combined with instruments, interfaces and setups for electronic real-time processing, as well as works involving multimedia and extended performative concepts in different formats. This list clearly demonstrates the range of technological, aesthetical and performative settings that electroacoustic performance practice has to cover today.

Electroacoustic performance practice, just like instrumental performance practice, therefore has to rely on thorough philological, historical and technological knowledge. It, too, has to establish aesthetical criteria based on a critical dialogue between history and present and must rely on craftsmanship and musical sensitivity in its realisations. Nonetheless, the contributions on historically informed performance practice and the critical examination of its discourses² illustrate the tension between the quest for historical foundation on the one hand and a presentation of the music oriented towards the present on the other hand, as well as the possible pitfalls of a historically informed performance practice. A broad understanding of historical conditions, the availability of unambiguous performance materials and ideal technical conditions do not guarantee sonic differentiation, liveliness and aesthetical relevance in a performance.

The idea of a restorative approach seems particularly problematic in electroacoustic music. This is largely due to the specific nature of electroacoustic instruments, as we will see later. Even if important issues may imply restoration processes, such as the repair and sonic improvement of performance material on sound carriers, the study of loudspeaker and sound source dispositions in historic performances, the allocation of channels intended by the composer,³ the understanding of historical devices and setups, or specific cases of reconstruction of devices and scores,⁴ all these processes and findings will serve as the basis for realisations under *current* technical conditions, rather than attempt to reconstruct historical settings.

A comparative look at historically informed performance practice of instrumental music from past centuries may help to clarify this idea. Although the issue deserves a much broader discussion, we shall at least outline some basic aspects.

There are significant similarities with regard to the fundamental aim of a historically informed practice as exemplified by Harnoncourt's undogmatic and practice-related approach, which dismisses the notion of a mere reconstruction of historic performances.⁵ In electroacoustic music as well, the aim cannot be to repeat historic performances, for instance from the early phase of electroacoustic music, which is also impossible despite the relative temporal proximity. However,

2 For a comprehensive discussion of texts on performance practice by Hans Hoffmann, Nikolaus Harnoncourt, Carl Dahlhaus, Hermann Danuser, Dieter Gutknecht, Howard Mayer Brown, Robert Philip, Benjamin Brinner and Jonathan Dunsby, see Hartmut Hein, *Musikalische Interpretation als «tour de force». Positionen von Adorno bis zur historischen Aufführungspraxis*, Wien, Universal Edition, 2014, pp. 339–415.

3 See the contribution by Pascal Decroupet in this volume, pp. 63–86.

4 See the contribution by Veniero Rizzardi in this volume, pp. 43–62.

5 «Wir wissen natürlich, dass wir nicht Aufführungen des 18. Jahrhunderts heute wiederholen, und wir wollen dies auch gar nicht. Wir stellen einfach die Musik mit den besten uns erreichbaren Mitteln dar, und dies ist legitimes Recht und Pflicht aller Musiker.» Niklaus Harnoncourt, *Musik als Klangrede*, Wien, Residenz Verlag, 1982, p. 115.

the quest for a lively representation of early electronic works using the best available means and the wish to re-contextualise them⁶ are concerns that are valid in electroacoustic music as well. An example for this is the restoration and remix to a modern surround format (5.1) of Varèse's *Poème électronique* by Kees Tazelaar. The original context and intended spatial effect of this work cannot really be experienced by listening to the officially available two-channel mix, which also has some technical issues, but is vividly conveyed by Tazelaar's mix based on thorough historical research.⁷ A piece that was perceived mainly as a historical document can now once more be musically experienced. The «acousmatic» version of Luigi Nono's *A floresta é jovem e cheja de vida*, realised by Veniero Rizzardi and Alvis Vidolin, as well as studies on Bruno Maderna's *Musica su due dimensioni* by this author⁸ are, each with its own context and motives, further examples of the quest for updated and lively presentations of historical works.

The similarity between the performance practices of music from before 1800 and of electroacoustic music is also of interest with respect to the issue of adaptation to specific situations. In older music, this concerns mainly the use of voice and/or instruments in musical works, but in electroacoustic music it concerns the sound projection over loudspeakers and its setup. In both cases, different solutions are possible. Electroacoustic pieces, too, have to be adapted to the spatial situation and technical conditions found in a specific space, especially as regards type, number and setup of loudspeakers and other sound sources and the approach taken in the spatialisation, depending on the layout, size and acoustics of the space. The selection of the individual components and the specific configuration of the electroacoustic devices also depend on individual preferences and habits. There is not one ideal solution but, each time, a decision has to be made taking into account the other pieces to be played and one's own performative approach.

There are also similarities with respect to the interrelation between musicology and artistic practice. The need for researchers with a deep understanding of performance practice and for experienced performers with an awareness of research issues also applies to our field. Musicological research on the performance practice of electroacoustic music requires a high degree of insight into production and performance conditions as well as technical knowledge. Conversely, today's performer has to be able to develop an understanding of philological and

6 See Hartmut Hein, *Musikalische Interpretation als «tour de force»*, cit., pp. 347–348 («Lebendigkeit») and p. 357 («Aktualisierung»).

7 See the CD *Les espaces électroacoustiques. Masterpieces in surround*, Vienna, Col legno, 2016 (WWE 2SACD 40002) and the comprehensive study about the original collaborative multimedia project in: Jan de Heer and Kees Tazelaar, *From Harmony to Chaos. Le Corbusier, Varèse, Xenakis and «Le poème électronique»*, Amsterdam, Uitgeverij Duizend & Een Publishers, 2017.

8 See the contributions by Veniero Rizzardi (pp. 43–62), Germán Toro Pérez (pp. 93–112) and Alvis Vidolin (pp. 113–136).

historical issues, to formulate questions and address them in practice. This is becoming even more important in view of the increasing relevance of artistic research. Ideally, this development will lead to a fruitful mutual dialogue and a common research practice.

Nevertheless, there are some fundamental differences mainly with respect to the nature of electronic sound itself, its production conditions, the properties of the electroacoustic instruments and the question of spatialisation, radically redefined in electroacoustic music. All in all, these create a completely new perceptive and aesthetical situation, affecting composers, performers and audiences alike and asking for a new type of specialised performer. A critical review of the concept of *instrument* within the composition and performance practice of electroacoustic music can help us to reflect on similarities and differences in comparison to instrumental music.

As is documented in Elena Ungeheuer's comprehensive study on electronic sound generation up to 1950,⁹ only very few of the musical instruments have survived that make use of electricity and are designed as autonomous systems consisting of sound generation units and control interfaces. The same can be said of many electronic instruments and prototypes built in the following decades. On the other hand, basic functions such as signal recording and playback, as well as sound processing techniques such as amplification, reverberation, panning, and filtering that have been used for decades and implemented in different ways, will continue to be available regardless of any given technological state. Moreover, the electroacoustic studio was always a mixture of devices that had initially been conceived and built for other purposes and had then been adapted to satisfy musical needs (from oscillators to computers) and of custom devices specifically conceived and built for use in the studio. The early setup of the Studio di Fonologia at the RAI in Milan is a very good example.¹⁰ In sum, we find technical devices related to specific historical and technological contexts, basic acoustic phenomena, musical functions, signal-processing techniques and interaction paradigms that can be implemented by different means, and we finally have the appropriation of non-musical technologies and techniques for musical purposes. All these aspects should be taken into account when reflecting on the nature of what we call an *instrument* within the context of electroacoustic music. Their interaction has so far led to the emergence and disappearance of innumerable instrumental devices and setups, making the idea of an instrument appear as fundamentally *open*, *hybrid* and *ephemeral*. In contrast, the concept of *instrument* within the context of instrumental music is largely based on *autonomous*, highly developed devices

9 Elena Ungeheuer, «Elektroakustische Musik», Vorbemerkung, in: Ludwig Finscher (ed), *Die Musik in Geschichte und Gegenwart*, Sachteil, vol. 2, Kassel, Stuttgart, New York, Bärenreiter Verlag, 1995, cols. 1717–1749.

10 See the contribution by Angela Ida De Benedictis in this volume, pp. 25–41.

with *generic* and *stable* characteristics and cultivated performance techniques. Nevertheless, the history of music also shows that any sound-producing object can be used in a musical context and can therefore be considered as a musical instrument. The instrumental practice of electroacoustic music, while relying on various generic devices such as microphones, mixing desks and loudspeakers, strongly reflects this fact. Today, almost any piece of electronic hardware can be integrated in an instrumental setup including universally used every-day objects. Microphones and loudspeakers can be seen as the prototypes of contemporary, ubiquitous communication devices regardless of their technical sophistication. Even if we refer to these common generic devices as instruments,¹¹ we must take into account that they are only functional if integrated in a system including other components like amplifiers, interfaces and transmission devices and are therefore not autonomous entities. Rather than instruments, they are *instrumental devices*. The idea of *instrument* in electroacoustic and computer music can therefore be understood rather as a *metaphor*, the single functions, objects and interfaces being the atoms of instrumental configurations of different degrees of complexity, changing characteristics and affordances and thus demanding and allowing for shifting performance techniques and skills. Moreover, the definition and implementation of work- and even site-specific instrumental configurations in electroacoustic music practice is an intrinsic part of the composition process and must also be considered as part of the performance practice. It may therefore be helpful to speak of *instruments* to refer to generic, stable and autonomous devices such as a violin, of *instrumental setups* to refer to hybrid and situational instrumental configurations like a given instance of an «acousmonium», and of *instrumental devices* such as computers, interfaces and loudspeakers as the functional components on which they are based.

This situation has practical consequences when it comes to taking decisions about instrumental setups and diffusion systems for specific works and venues. What should be provided for a specific performance situation, specific devices, their underlying functionality, or a mixture of both? What criteria should be applied to fulfil a historically informed performance's intention to present a piece in a way that makes perceivable its auctorial conception and historic context to a contemporary audience? While those questions must be answered with regard to specific works and the intended performance situation, a general approach seeking to *restore* a certain technological state as a prerequisite for a historically informed performance practice appears to contradict the nature of instrumental setups in electroacoustic music, not even taking into account practical issues like obsolescence, reliability, functionality, practicability and actual sound quality (noise-to-signal ratio, dynamics, consistency of the spectral and spatial image,

11 See Cathy Van Eck, *Between Air and Electricity: Microphones and Loudspeakers as Musical Instruments*, New York, Bloomsbury Academic, 2017.

etc.). Even if current performance practices may reflect the emergence of widely used devices and tools, it is hard to imagine that this will lead in the future to a practice relying mainly on a set of standardised, stable and autonomous instruments.

The similarities and differences regarding the idea of a historically informed performance practice in electroacoustic music as discussed above raise the question of the specific function of the performers in charge of the electroacoustic part. This new practice has so far led to the emergence of a new type of musician, the electroacoustic performer, also called «sound director», or «sound projectionist», in charge of multiple tasks: instrument building and/or software development, system design, sound engineering, direction of rehearsals and work with conductors, instrumentalists, singers and other performers, and, finally, performing with different setups, frequently under exposed and strenuous conditions.¹² If we add to this the need for research skills with regard to philological, historical and aesthetical issues, as well as technological skills in view of today's aesthetical and technical multiplicity, it becomes obvious that the demands are extremely high. They include tasks expected from sound engineers, instrumentalists and conductors, the electroacoustic performers in most cases taking a specific hearing perspective embedded in the audience and therefore mediating between the composer's intention, other performers, the technology involved and the listeners. Conductors, instrumentalists, singers and other performers, too, find themselves confronted with new perceptive, technological and aesthetical situations and have to face new challenges, including dealing with microphones, click tracks, computers, monitoring, specialised interfaces and augmented instruments, as well as understanding processes and techniques that allow them to communicate and interact with composers, sound engineers and electroacoustic performers.

The emergence of a new type of performer and the institutional context necessary to support and develop such a technologically demanding practice led to the appearance of specific performance traditions. This observation brings us closer to the situation of early electroacoustic music practice and to the context of studios such as the Studio di Fonologia musicale della RAI di Milano and their repertoires.

Not all early electroacoustic compositions were created with a clear idea of their performance in a concert situation. Some works that today appear on concert programmes, among them early works from studios operated by broadcast companies, such as the Studio di Fonologia or the electronic studio of the Westdeutscher Rundfunk (WDR) in Cologne, were originally intended for radio broadcasts. Their concert performance practice had yet to be developed. Thus, there are cases where no auctorial performance practice can be traced because the composers were not involved in concert performances or did not intend for

12 See Alvisé Vidolin, «Musical interpretation and signal processing», in: Curtis Roads, Stephen Travis Pope, Aldo Piccialli, Giovanni De Poli (eds), *Musical signal processing*, Lisse, Swets & Zeitlinger, 1997, pp. 439–459.

their work to be presented in concert. György Ligeti saw the work *Glissandi*, his first composition at WDR's electronic studio, as a mere «exercise». This notion may explain why Ligeti apparently never performed it and showed no interest in it. There is thus no performance tradition that could serve as reference for performances today. In other cases, technical information related to performance were not documented at all, or only cryptically, by composers or involved performers.

With respect to the works from the Milan Studio di Fonologia, the development of a performance tradition is naturally directly related to the biographies and the artistic approaches of its composers. Despite their different artistic profiles, the studio's three major exponents, Luciano Berio, Bruno Maderna and Luigi Nono, were from the beginning involved in the performance process, and Berio and Nono also changed their approach to some of their works over the years. In later years, Berio's and Nono's collaboration with specific institutions (Berio at Tempo Reale in Florence, Nono at the Experimentalstudio in Freiburg) was instrumental in the emergence of a performance tradition of their works.

An overview of electroacoustic performance practice thus demonstrates that, despite all the difficulties, general performance cultures and work specific traditions could be developed. General performance approaches, such as the nowadays commonplace sound projection over multiple loudspeakers distributed in the concert space, evolved in different places along with specific aesthetical and technological peculiarities. Ideally, the ground for performance traditions was prepared by composers themselves, acting as performers of their own works, their approaches possibly being further developed subsequently and documented in detail. Only rarely do performers or institutions possess and pass on such first-hand knowledge. Among the institutions with a longstanding, distinctly auctorial performance tradition we find today the GRM and IRCAM in Paris, the Experimentalstudio in Freiburg, Tempo Reale in Florence, the Institute of Sonology in The Hague and the Stockhausen-Stiftung für Musik in Kürten, Germany. Other institutions such as the ZKM in Karlsruhe, the Birmingham Electroacoustic Sound Theatre at the University of Birmingham and the now closed Institute de Musique Electroacoustique de Bourges have developed specific performance systems with differing degrees of auctorial involvement. There are other institutes and studios today, such as the Institute for Electronic Music in Graz and the ICST in Zurich, which offer residencies for composers. However, not all institutions are able to concern themselves in a sustainable manner with the performance of the works created there. It is mostly the composers themselves (and only rarely publishing houses these days) who have to ensure that works can be performed in the future. It is thanks to the vision of archives such as the Paul Sacher Stiftung in Basle and, among others, the institutions mentioned above, that performers and researchers can today benefit from collections that have been built and curated over decades. Still, source materials and documentation for many works are scattered over

different private archives and individual estates of composers and performers, so that accessing them remains a challenge.

This situation presents today's performers with many difficulties, before the musical work can even begin. While in the context of instrumental performance practice, it is generally understood that, apart from the professional qualifications of the performers, it is essential that primary sources, dependable editions, and adequate performance materials should be available, or that instruments used should correspond to a certain quality level, or that adequate setup and rehearsal conditions should be provided. This still cannot be taken for granted in electroacoustic concert practice. Not all publishers, ensembles, conductors and organisers take all of these aspects into account when preparing performance material or when planning rehearsal and production processes. These issues can only be solved through close cooperation of different players. The prerequisite for this is systematic, reliable and easily accessible information on all aspects relevant to the performance of specific works. It goes without saying that the collaboration of performers, musicologists and archives will have to play a major role in achieving this. In a further step, institutions concerned with the preparation and distribution of performance material will have to become involved in this process and, finally, organisers, curators and ensemble directors will have to become aware of the need for an electroacoustic performance practice culture.

This appraisal from the perspective of a composer-performer is meant as a contribution to a problematic and to the establishment of a discourse that is still in its early stages. An in-depth discussion on the specific conditions for a historically informed approach to electroacoustic music has yet to take place. The historical distance is small, the repertoire is known mainly in specialised circles and the practice is still a specialised field within a specialised field, both in contemporary music and in musicology. In view of the growing number of electroacoustic works that are created each year, however (a development that is favoured by the almost universal access to electroacoustic means), we can predict today that the electroacoustic performer's practice, if only for statistical reasons, will have a place within musical life and that the questions related to it will become more urgent.

About the research project

The «Performance Practice of Electroacoustic Music – The Studio di Fonologia Years» project, from which this publication evolved, and the subsequent project, «Performance Practice of Electroacoustic Music – Towards a Practice-Based Exchange between Musicology and Performance», were conceived as a contribution

to this problematic. Both projects were initiated at the Institute for Computer Music and Sound Technology (ICST) of the Zurich University of the Arts (ZHdK). The first project was made possible through collaboration with Maddalena Novati, then curator of the now closed Archivio di Fonologia of the RAI in Milan, a contact that had been initiated by the composer Francesco Paradiso. This unique collection immediately made us want to explore and study the repertoire. After the publication of the archive's catalogue by Maddalena Novati,¹³ which systematically lists all the works that were created at the Studio di Fonologia between 1955 and 1983, it seemed like the next logical step was for us to study the performance aspects of these works. Mrs Novati, who was enthusiastic about the project, introduced us to the musicologist Angela Ida De Benedictis, then director of the Centro Studi Luciano Berio. With her help we were able to build a broad network of experts and institutions that would serve as an ideal basis for the realisation of the project.

The most important premise for this project was that it could only be realised in a dialogue between musicologists and musicians because it involved many aspects that could not have been dealt with in any sufficient depth by performers alone. The two-year project was financed through internal funding by the Zurich University of the Arts. It was structured in four workshops in which specific works were thoroughly discussed and if possible presented in concert. The point was made that, during the discussions and presentations, one should be able to listen to the various materials in the appropriate formats, so as to create a listening environment that would approximate the concert situation.

The concept proved ideal from the beginning, and the mutual exchange was most inspiring. Two workshops were held at ZHdK, one at Tempo Reale in Florence and one at the Conservatorio Cesare Pollini in Padova. A board of experts with musicologists, performers and archival specialists (Maria Maddalena Novati, Veniero Rizzardi, Nicola Scaldafèri, Alvisè Vidolin) worked continuously with the core team consisting of Germán Toro Pérez, Angela Ida de Benedictis and Lucas Bennett. Depending on the repertoire, this configuration was expanded and other experts were invited, among which Nicola Bernardini, Lelio Camillieri, Pascal Decroupet, Francesco Giomi, Stefan Litwin, Angelika Lutz, Ulrich Mosch and Kilian Schwoon. Numerous institutions of international renown were willing to support the project.¹⁴

The original idea to publish the results in the form of a handbook with systematic monographic entries on the specific works, addressed mainly at electroacoustic performers, was abandoned in favour of the present publication's concept, as it became clear that it would first be necessary to grasp the complexity of the field and

13 Maria Maddalena Novati and John Dack (eds), *The Studio di Fonologia – a musical journey 1954–1983*, Milano, Ricordi, 2012.

14 See complete list of partner institutions below.

to make it visible, taking into account the specific properties of the works created at the Milan studio. The selection of works, a demanding task in view of the overall quality, historical relevance and size of the collection, was made in such a way that different work typologies and the main problem areas would be covered. These areas are reflected by the structure of the present publication.

The idea of a handbook was, however, taken up and further developed within the ensuing research project. In late 2016, the *Electroacoustic Performance Practice Database*, containing work-specific entries, was published online and is intended to be continuously expanded. The SACD *Les espaces électroacoustiques. Masterpieces in surround*, published in 2016 by the label col legno, was realised within the same project, which was based mainly on works held at the Paul Sacher Stiftung in Basle. It documents different performance approaches and contains several works realised at the Studio di Fonologia, among others.

About the publication

The texts presented in this book cover a wide range of aspects inherent in the performance practice of electroacoustic music. These are systematically exposed by Ulrich Mosch in his opening text, defining a state of affairs in the field from the perspective of the practice demanded by the works composed at the Studio di Fonologia.

Angela Ida De Benedictis' text focuses on the production conditions at the early stage of the studio as reflected in the work of Bruno Maderna. Starting from a recapitulation of his path towards electronic music, it elaborates on the inter-relationships between composers and machines and focuses on *Notturmo*, one of the first pieces composed at Fonologia. Her final remarks on notation coincide with Veniero Rizzardi's point of departure for a discussion of notation processes, the reconstruction of «oral scores» and the performance of *A floresta é jovem e cheia de vida* and *Un volto, e del mare* by Luigi Nono, originally intended as live performances and only fixed through sketches, annotations and the memory of the performers.

Pascal Decroupet's study on Stockhausen's early performance practice of *Gesang der Jünglinge*, a piece composed at the electronic studio in Cologne (a diversion from our Fonologia context), sheds light on the development of its performance practice and proposes an approach that elucidates the original conception and Stockhausen's own early performance practice. This raises the interesting issue of dealing (critically) with auctorial performance practices. In the section dedicated to *Scambi* by Henri Pousseur, another important composer

closely linked to the Studio di Fonologia in its early years, Decroupet introduces a further aspect of performance conditioned by the idea of open form. In the last section, which is devoted to Pousseur's *Rimes pour différentes sources sonores*, the author discusses the spatial conception of the first version (1958–9). This is complemented by Kilian Schwoon's report on the revision process that led to the new multichannel version of the piece, realised at Tempo Reale (2005–6) in collaboration with the composer. These contributions are further complemented by three unpublished source texts by Pousseur on *Rimes*, transcribed and edited by Pascal Decroupet, including the complete version of a text written 1961, which contains additional information about the genesis of the third movement, as well as more recent ideas that led to the new version of the electronic part. They are included in the appendix.

The contribution on Maderna's *Musica su due dimensioni* is based on the comparative study of three historical recordings of early performances of the piece, advocating a more lively interaction between the two performers and highlighting the tape's potential in view of the open form concept proposed by the composer.

Finally, Alvisi Vidolin's approach to performance practice, based on his broad experience with the Fonologia repertoire and his collaboration with the composers, is documented in his detailed discussion of *Visage* by Berio, *La fabbrica illuminata* and *sofferte onde serene ...* by Luigi Nono. The general exposition and the work-specific discussion of his own practice offer an invaluable model for new generations of electroacoustic performers.

Acknowledgment

This publication was made possible thanks to the close collaboration of a group of researchers and performers, supported by a broad network of institutions and archives. Alongside the authors Angela Ida De Benedictis, Pascal Decroupet, Veniero Rizzardi, Kilian Schwoon and Alvisi Vidolin, we would like to thank Lucas Bennett for his musicological advice and invaluable contributions as translator, proof reader and coordinator.

We are deeply grateful to our institutional partners, above all to Maddalena Novati for the enthusiastic collaboration, to the RAI for their support throughout the project, to Francesco Giomi and Tempo Reale, Kees Tazelaar and the Institute of Sonology, the Conservatorio Cesare Pollini in Padova, the Sound and Music Processing Lab, Padova, the Centro d'Arte degli studenti dell'Università di Padova, the Paul Sacher Stiftung, Basle, the International Music Institute Darmstadt, the

Archivio Luigi Nono, Venice, the Centro Studi Luciano Berio, Florence, as well as to the editors Ricordi, Schott, Suvini Zerboni and Universal Edition.

Finally, we thank Dominik Sackmann and the Institute for Applied Music Research at the Zurich University of the Arts for including this book in the *Zürcher Musikstudien* series in collaboration with Peter Lang Verlag, Bern.

ULRICH MOSCH

Some problems of the present-day realisation of historical electronic pieces

This text is based on an introduction given by the author at the first workshop within the project «The Performance Practice of Electroacoustic Music – The Studio di Fonologia Years», Zurich University of the Arts, 9 October 2012.

Reading the various comments in the exchange of e-mails preceding our meeting, and thinking of the enormous variety of aspects touched upon, I thought the most useful thing regarding my contribution could be to attempt – as we are at the very beginning of our discussions – a kind of systematisation of the field under focus. There are six main areas on which I would like to briefly comment, and one additional aspect: 1) the compositional process, 2) the notion of the work in electronic music, 3) the first performance of a piece and its circumstances, 4) the venues of performances today and their specific acoustic conditions, 5) performance and audience, 6) authenticity, and – just as a speculation – 7) the possibility of a remake or recomposition of historical works with present-day technical means.

1. The compositional process

In electronic music, the first time technology comes into play is during the compositional process, and this happens from the very beginning – from the creative inception, so to speak. To conceive a piece – as there is no instrument that would imply characteristics you can think of, but simply possible sounds – necessarily involves considerations, on the one hand, about the available sound-producing devices (oscillators, sound generators, filters, ring modulators, etc.), and, on the other hand, of procedures of sound manipulation and the sound's organisation in time. Furthermore, the technical realisation of a composition in the studio – whether it is the realisation of a pre-existing concept or score or if it is a step-by-step realisation in a kind of dialogue with the machines – is based primarily on montage, again meaning that it is based on technology.

2. The work in electronic music

The result of the creative/technical production process is the electronic work. In this particular case, the work is not fixed as a written score, but as a «sound object» on analogue tape – at least in the historical period we are dealing with, where this type of tape represented the most advanced technical means of recording. The question, however, is: What could be considered «the original» – corresponding to the autograph score of a notated piece of music – «the» tape, representing the work, so to speak, in its intended and definitive form? Tape, like photography, is a medium of reproduction. Copies of a tape are, with respect to sound, identical (or at least almost identical) to the «mother tape», so the two main criteria that allow «the» tape to be identified are a) the position within the chronology of the genesis of the work and b) the completeness of the piece fixed on a particular tape: The «original» of an electronic piece is the earliest tape representing it in the definitive version. The question of whether there is only one single and definitive version or whether there are perhaps different versions has to be decided on the basis of the same criteria.

Related to the «original» tape representing «the» work is, inevitably, the question of its acoustic quality. A tape from the late 1950s might sound poor to our ears today with respect to sound quality. How should we deal with this fact? A composer, when dealing with his own composition, could no doubt intervene later, if necessary. And there might be good reasons to do so, even if the manipulation will modify the «original» sound object: as in the case of Luciano Berio, to give but one example, who in *Thema (Omaggio a Joyce)* later reduced noise and shortened pauses. For performers this is a much more complicated issue. In some cases, however, it might even be useful, desirable or simply possible for a performer to do the same, if justified unambiguously through aesthetic reflection.

3. The first performance of a piece and its circumstances

Regarding this topic, many different aspects have to be discussed. First, the sound quality of the original tape, if preserved at all, since tapes are ageing and quality is diminishing. Second, the quality of the loudspeakers and the amplifiers inevitably modifying what was reproduced from the original tape. A third aspect is the dynamics. What do we know about this aspect regarding the first performance? Finally, a fourth aspect is the spatial projection of the sound, because with electronic music or music on tape in general, the composer, dealing only with loudspeakers and not with musicians, is no longer obliged to present the music

from one particular place – the stage, for example. While a musician cannot hang from the ceiling of the concert hall, a loudspeaker can do so without any problem. The composer can put the loudspeakers wherever he wants. At the same time, the composer dealing with music to be presented via loudspeakers *has* to decide where to put them. If he does not decide and prescribe, others will, or will have to do it. This is inherent in the whole approach of music played over loudspeakers, and not by musicians. Finally, depending on the size and the characteristics of the venue of the first performance, there are all the questions related to acoustic reflection, reverberation, delay, and so on.

4. The venue of performance of today and its specific conditions

If you are thinking of a concert with electronic pieces in a specific concert hall or at another venue of our time, you have to deal on the one hand with the particular acoustic conditions of the hall. On the other hand, there is all we know about the first performance and its circumstances – one of the aspects explored by the present project.

Consequently, there are two perspectives in play: a) the historical perspective, i.e. the first performance seen as a historical event, which we can try to reconstruct. Maybe we can find out about the positioning of the loudspeakers, the amplifiers used, and, perhaps, about certain constraints imposed by the context in which the respective piece was presented for the first time. Then we have b) the present-day perspective, i.e. the conditions of a presentation today, implying new technological means, new concert halls or other venues, public spaces, wherever you intend to present a piece. If you do not want to present a reconstruction of a historical performance, you have to try to present the pieces in the best way under the spatial and acoustic conditions of the specific hall you are dealing with. This double perspective – the historical event and the presentation under today's circumstances – is a very important issue regarding the main question of interest in this research project: how should a piece be presented for the public today?

5. Performance and audience

In social terms you can think of the audience: a) as a certain number of people interacting in a concert hall, or b) as a mass of individuals, for example when people are alone at home or in their cars and listening to the same radio programme

as many others. There is certainly a big difference regarding acoustics and space, but also regarding mood, opinions you do or do not share with your neighbour or people around you, and so on. It makes a difference if you listen to electronic music in a public context at a concert hall or in a private context, when you are at home, where you put on an LP or CD or switch on the radio or the Internet. These various contexts are related to quite different listening conditions.

During the presentation of a piece in a concert hall there is a kind of dynamic interaction between the members of the audience – everybody knows this from traditional concerts. There is a similar interaction in a performance of electronic pieces at a concert hall.

In the 1950s, exactly at the time when fixing sounds on tape became one important way of producing music, there was an interesting discussion on similar phenomena regarding the cinema. French author Edgar Morin published a book in 1956 about the anthropology of the cinema.¹ One of the main questions on which he was reflecting concerned the fact that in a cinema you no longer have actors on stage. Instead you have pictures projected on screen. So there is no longer any interaction between stage and audience. The same is true for concerts with electronic music. Nevertheless, in both cases the attitude of the audience remains similar to that at the theatre and the concert hall, respectively. What is going on and what is shared by all people attending is a kind of «magic event», implying interactions within the audience.

Another interesting issue concerns the audience's expectations and experiences. Audiences in the 1950s who heard electronic music – very likely often for the first time – reacted to it in a way that was completely different from our reactions today: people today are used to listening to these type of sounds via film music, via all kinds of technical devices like cell phones and computers. The background of experience has changed enormously during the last fifty years.

6. Authenticity

I would like to leave behind all discussions about authenticity. Nobody can judge whether a presentation of a piece of electronic music is «authentic» or not. We can try to make a historical reconstruction but it is impossible to say «this is authentic», and «that is not». We might judge what comes closer to what was described, for example, by people who were present at the first performance. Categories like «Urtext», authenticity or whatever else are very problematic and might in many

1 See Edgar Morin, *Le cinéma ou l'homme imaginaire: essai d'anthropologie sociologique*, Paris, Minuit, 1956.

cases even be misleading. Instead, we should try to find different categories under which to discuss this aspect.

In one of his comments in the e-mail exchange, Veniero Rizzardi had spoken about the fact that it is impossible to change our ears: we cannot get out of today's world of experiences, so we have to deal with them. We cannot escape our time and get rid of all the experiences we have; they are present in a kind of sediment in our ears, and we are inevitably listening with this background. Pieces like *Continuo* or *Omaggio a Emilio Vedova* are, in this respect, musical works, and at the same time they are, like a Beethoven symphony, documents of their time, including all the aspects of sound quality, and so on.

I would like to plead for something that is quite similar to the challenge of presenting early music in our days from our perspective, a challenge that was discussed widely in the 1950s and 1960s in the early music movement: Without any doubt we have to care about the historic presentation as it was at the time of the first performance of a piece; we have to be aware of it. But in the end, we have to decide starting out from our own context, and not from a historical one. It is not possible to return to another historical period. This is true at all levels. The concert halls are different today – we have for example air conditioning with all the related noises; so, the acoustic conditions are different; we have different loudspeakers and amplifiers – we no longer use tube amplifiers, and so on. We could try to find all the historical technical devices on the antiquarian market but, I guess, this would not make much sense. The other way around is much more interesting.

It is, however, really important to know about the historical circumstances. Just to stress one point: Veniero Rizzardi gave the example of an unbroken tradition of performance of Romantic music. But when you listen to early recordings, for example Camille Saint-Saëns playing Mozart, Chopin or Bach in 1905, it is very disturbing what he does. It is so alien to our conception of that kind of music that I doubt that, had we had the opportunity to listen to Bach or Beethoven themselves via recordings, this wouldn't be a very, very strange, disappointing, even disturbing experience.

This is only to say that we have to be quite careful with these kinds of extrapolations, and I guess there is a similar situation regarding electronic or tape music.

7. The possibility of a recomposition with present-day technical means

Dealing with pieces of the 1950s, you could get the idea to try to do it better than the composers themselves in their time. There is always the temptation to do so. When you have a realisation score of Stockhausen, it is possible to follow

his procedures today and to put the piece together with the most recent technical means. Indeed, a very interesting issue. But is it useful? Is it perhaps something you should never touch upon? In some cases, however, the sound of the original tape might be so distorted that you are confronted with the question of whether you could or should do it. So this is a kind of systematic layout of the field under focus and some problems related to it. Maybe there are other aspects we should add that I did not cover. But the discussion will bring these to the fore.

The beginnings of the Studio di Fonologia Musicale and Bruno Maderna's *Notturmo*¹

For Maddalena, with gratitude and great affection

In the artistic life of Bruno Maderna, electronic music plays a central role. The composer, who was born in 1920, was one of the first musicians of his generation to experiment with the new electronic devices and was, together with Luciano Berio, founder of Radiotelevisione Italiana's (RAI's) Studio di Fonologia in Milan, one of the most important electronic laboratories in post-war Europe.

Maderna's first encounters with electronic music date back to the beginning of the 1950s, when he attended some meetings dedicated to new ways of sound generation at the Darmstadt summer school. It was in Darmstadt, in 1951, that Maderna had the opportunity to take part in the cycle *Musik und Technik. Die Klangwelt der elektronischen Musik (Music and Technology. The Sound World of Eelectronic Music)*. Besides lectures given by pioneers such as Herbert Eimert, Friedrich Trautwein or Pierre Schaeffer, he also listened to some sound examples presented by Meyer-Eppler of the Institut für Phonetik und Kommunikationsforschung (Institute for Phonetics and Communication Research) of Bonn University. It was there that Maderna came to his electronic «Christening», since

1 The following is the text of a lecture titled «*Notturmo*» von Bruno Maderna und das «Studio di Fonologia Musicale di Milano», which was given at the Haus der Wissenschaft, Bremen on 1 July 2015 (Atelier Neue Musik, Serie: «Scanned. Elektroakustische Musik im Fokus»). The text presents a synthesis of research and findings presented in various essays that have appeared in several places between 2000 and now. We would refer the reader in particular to the book *Nuova musica alla radio. Esperienze allo Studio di Fonologia della RAI di Milano 1954–1959 / New Music on the Radio. Experiences at the Studio di Fonologia of the Rai, Milan 1954–1959*, ed. Veniero Rizzardi and Angela Ida De Benedictis, Roma, RAI-CIDIM, 2000; and to Angela Ida De Benedictis, «Bruno Maderna et le «Studio di Fonologia» de la RAI de Milan», in *À Bruno Maderna*, ed. Giordano Ferrari, Laurent Feneyrou and Geneviève Mathon, vol. II, CNRS Paris I, Paris, Basalte, 2009, pp. 389–421; Id., «Bruno Maderna e lo Studio di Fonologia della Rai di Milano: musica d'arte e d'uso tra creazione, ricerca e invenzione», in *Musica/Realtà*, XXX/91, 2010, pp. 43–75; Id., ««A Meeting of Music and the New Possibilities of Technology». The Beginnings of the Studio di Fonologia Musicale di Milano della Rai», in *The Studio di Fonologia. A Musical Journey 1954–1983. Update 2008–2012*, ed. Maria Maddalena Novati and John Dack, Milano, Ricordi, 2012, pp. 3–18; Id., «Riflessi del suono elettronico: sinergie e interazioni nell'orizzonte compositivo di Luciano Berio», in *Luciano Berio. Nuove prospettive / New Perspectives*, ed. Angela Ida De Benedictis, Firenze, Olschki, 2012, pp. 293–336.

it was at the Bonn institute that, with the assistance of Werner Meyer-Eppeler, the composer realised his *Musica su due dimensioni* in 1952 – a piece for flute, tape, and cymbal that was revolutionary for its time and in which Maderna attempted to realise an encounter of synthetically produced and instrumental sounds (played live).² While this attempt was undertaken before the time was really right for it, one has to acknowledge that, from the start, Maderna's experiments with electronic music were different from those realised by composers such as Pierre Boulez or Karlheinz Stockhausen. In contrast to them, the use of electronics for Maderna required a «dialogue» between the two «dimensions», the instrumental and electronic dimension, and not a «puristic» approach or the radicalism, which was especially typical of the early experiments at WDR's electronic studio in Cologne.

Between *Musica su due dimensioni* and the opening of RAI's Studio di Fonologia Musicale, however, another three years were to pass. During this period Maderna's biographical and artistic paths crossed those of the younger Luciano Berio, whom he met in 1953. Among their many common interests, electronic music was certainly one of the liveliest. Their meeting was preceded by Berio's first encounter with transformation and editing techniques of sounds on tape, which in Berio's case didn't take place in Europe but in America. On 28 October 1952, he had attended a concert for tape recorder in New York, featuring pieces by Vladimir Ussachevsky and Otto Luening. Although Berio felt this music to be of «very little musical value»,³ the potential inherent in these instruments immediately aroused the composer's interest. Berio also instantly realised that the tape music sounds were ideally suited to the diverse demands of «radio, television and film scripts». ⁴ It was for this reason that, upon his return from America, Berio established his first contacts with the Italian broadcast company RAI, for whom he had already worked as a musical consultant and synchro assistant. In 1953, he was able to realise, almost in secret in a room at RAI, his first completed electroacoustic study, entitled *Mimusique*.⁵ It was an «example of Concrete Music as a form of art» with a duration of only 2 minutes, and featured just three

2 In 1958 Maderna used the same title for another and totally different composition for flute and tape – see the contribution by Alvis Vidolin «Sound direction of 1950s and 1960s tape pieces from the Studio di Fonologia» in this volume, pp. 113–136.

3 See Luciano Berio, «Musica per Tape Recorder», *Il Diapason*, IV/3–4, 1953, pp. 10–3: 11 (now in *Luciano Berio. Scritti sulla musica*, ed. A. I. De Benedictis, Torino, Einaudi 2013, pp. 173–179). On 28 October 1952, the programme featured *Sonic contours* by Ussachevsky and *Low Speed, An Invention on a Twelve-Tone Theme* followed by *Fantasy in Space* by Luening.

4 *Ibid.*, p. 13.

5 On this short piece of concrete music, see Angela Ida De Benedictis and Veniero Rizzardi, «A Conversation with Luciano Berio», in *New Music on the Radio*, cit., pp. 160–175: 162–164 (for the next quotation in the text *ibid.*, p. 262). *Mimusique*, unpublished, was included in the programme «La Musica Concreta», curated by Berio himself in 1955 and broadcast on 13 July of the same year (see *Radiocorriere*, XXXII/28, 1955, p. 24). The recording of the programme

materials: a gunshot, a tam-tam strike and a sound produced by a human voice. Berio remembered having realised *Mimusique* with few and simple devices such as filters, oscillators, white-noise generators, and speed control.⁶

With the same basic means Berio and Maderna in December of 1954 recorded *Ritratto di città*, a radio documentary featuring Milan that helped to put into practice the plans to finally found an electronic studio at RAI, such as they already existed in Paris and Cologne.⁷ Only a month before creating this radio documentary, Maderna had written a letter to Berio in which he enthusiastically agreed to plans to work together in electronic projects:

Dear Berio,

I came on Saturday morning at 12 (well, 12.10) to the Rai but you weren't there. –

At any rate, I shall be in Milan on Wednesday morning – I'll come and see you. – I feel enthusiastic about working with you on the possibilities of «musique concrète» and «Elektronische Klangerzeugung»– Once in Milan I'll tell you the reasons I would love such a cooperation so much. –

I hope we'll be, at last, together.⁸

With the radio documentary *Ritratto di città* the two composers succeeded in convincing the RAI directors of the necessity to set up a studio for electronic music that would also (or above all) be used for producing functional music intended for radio comedies or TV productions. This «Studio per una rappresentazione radiofonica» (study for a radio play) has to be understood as an «exercise» or initial experiment rather than a «thematic prelude» anticipating, in terms of poetics and aesthetics, the electroacoustic works Berio and Maderna were to create subsequently at the Studio di Fonologia of the RAI in Milan. One should not forget that *Ritratto di città* was an occasional piece that came out of the cooperation of the composers with the author of the text, Roberto Leydi, conceived and created contemporaneously, both started and completed in December 1954. Moreover, the scant materials used – whether concrete or electronic – reflect the paucity of technical instruments available at the time, with «dramaturgic» and «expressive» intentions more akin to *Gebrauchsmusik* than art.

is preserved in the sound archive of the Studio di Fonologia Musicale (tapes «Fon. 019» and «Fon. 020»); see *The Studio di Fonologia. A Musical Journey 1954–1983*, cit., p. 180).

6 See «A Conversation with Luciano Berio», cit. (note 5), pp. 160–166.

7 The radio documentary *Ritratto di città* was published in 2000 in the CD accompanying *New Music on the Radio*, cit. (note 1). Please refer to this publication for further information on the piece.

8 Letter preserved in the Paul Sacher Foundation (Basel), Luciano Berio Collection; published in *New Music on the Radio*, cit. (note 1) p. 30.

After this first test piece, the Studio di Fonologia inaugurated its activity in June of 1955, initially using provisional equipment.⁹ The very first electronic pieces realised in this «provisionary» studio were *Sequenze e strutture* by Maderna (1955) and *Mutazioni* by Berio (1955–6). The official opening then came in May of 1956, along with new technical equipment that was ground breaking for the time (the equipment included the famous panel with nine oscillators). With the new devices began the great period of Italian electronic music, which started with Maderna's *Notturmo* (1956) and continued with *Syntaxis* (1957), *Continuo* and *Musica su due dimensioni* (both 1958), and also *Perspectives* (1957), *Thema (Omaggio a Joyce)* (1958) and *Momenti* (1960) by Berio.

In contrast with the orientation of the Cologne studio, the Studio di Fonologia was, from the beginning, less strict in terms of planning and more open towards experimental solutions suggested by the direct work and manipulation with the sound material. The electronic works by Berio and Maderna were from the beginning characterised by creative freedom and the absence of the kind of radicalism typical of compositions by Stockhausen or Koenig, works which were conceived according to a serial compositional logic and strict calculations. Maderna himself confessed with respect to his beginnings: «When I started to compose with electronic means, I feared above all to use them inadequately. In order to overcome this fear, I would rather count on my musical intuition than on rational prejudice».¹⁰ The fact that he had the chance to work almost daily in an electronic studio with oscillators and tape machines eventually changed his view not only on technology, but on the way in which he generally approached and thought about music. In 1957, one year after he had composed *Notturmo*, he said:

The encounter with electronic means led to a real revolution with respect to my own relationship to the musical sound matter. Here, the composer's intellectual metabolism has to completely readjust itself. In instrumental composition, the development of ideas usually progresses straight ahead in a linear fashion, precisely because it concerns a development of ideas that does not find itself in constant contact with the matter. Contrary to this, the fact that in the electronic studio it is possible to immediately test one's ideas of sound structures, the fact that one can through constant manipulations of the materials thus created [...] change and renew them and finally that one can in this way build a supply of musical subcomponents, confronts the musician with a new situation. The time now presents itself [to the musician] as a field

9 The name «Studio di Fonologia musicale» was apparently suggested by the RAI board member Gino Castelnuovo (cf. Gino Castelnuovo, «Lo studio di Fonologia Musicale di Radio Milano», *Elettronica*, III, 1956, pp. 106–107; cf. also Nicola Scaldaferrì, *Musica nel laboratorio elettroacustico. Lo Studio di Fonologia di Milano e la ricerca musicale negli anni Cinquanta*, Lucca, LIM 1997, p. 67).

10 Bruno Maderna, *Kompositorische Erfahrungen mit der elektronischen Musik*, lecture at Darmstadt, 26 July 1957; the original audio recording in German is held at the Internationales Musikinstitut Darmstadt (Italian translation published in «Esperienze compositive di musica elettronica», in *Bruno Maderna. Documenti*, ed. Mario Baroni and Rossana Dalmonde, Milano, Suvini Zerboni 1985, pp. 83–85: 84).

of many possibilities to permute and organise this produced material. We now feel a strong propensity for this type of thought and practice in instrumental music as well.¹¹

The composer in the studio became an «artisan» of sorts who was able to intervene directly in the *physical* generation of the sound. Through the generation and transformation of sound data, he «fabricates» his work in the truest sense of the word. The cutting and splicing of the tape sequences, the synchronising of the tapes and the diffusion of sounds in space were not merely technical processes: they required skilfulness, so every single step had to be evaluated diligently and the resulting sound had to be controlled step by step. Often this constant checking led to surprising and unplanned sound results, necessarily leading composers such as Berio or Maderna to mix strict planning with a more direct «intuitive» approach.

Before taking a closer look at the first works produced at the innovative Studio di Fonologia, I would like to share a more general thought about the concept of «electronic music» as such and its compositional methods. When we talk about the «electronic music» of the 1950s, we tend to think of a certain way of composing entailing the use of sound material artificially generated by electronic devices and synthetic sound material experimentally generated by the composer, where, with the help of a technician, he «invents» his *own* sound and the piece, from the most elementary level of a single frequency to the more complex level of form. Beyond this immediate association, much less is known about the processes that made this artificially generated material become «music». If we apply these general concepts to an electronic studio such as RAI's in Milan (and to the technical means that were available there at the time), it is nevertheless not enough to understand exactly which peculiarities made the studio an experimental treasure trove distinguished from the other studios in Paris, Cologne, Tokyo and so on. It is known, for example, that the famous panel with its nine oscillators, about which much has been written, was the «instrument» distinguishing the Studio di Fonologia from every other studio in the world (see Figure 1). But until recently, nobody had thought about the fact that the single oscillators were first calibrated differently, which, looked at more closely from a musical perspective, points at a highly interesting fact.¹² As measuring instruments that had originally been made for non-musical purposes, the oscillators were fitted to certain frequency ranges covering a bandwidth of 0.0010 Hz to 1 MHz. When the nine oscillators were installed in the studio (the year is 1956) each one was tuned to certain frequencies in order to achieve more precision and stability (Figure 2).

11 Bruno Maderna, *Kompositorische Erfahrungen mit der elektronischen Musik*, cit. (cf. also *Bruno Maderna. Documenti*, cit., p. 83).

12 Figures 1–5 are taken from my article *Riflessi del suono elettronico: sinergie e interazioni nell'orizzonte compositivo di Luciano Berio*, cit. (note 1), pp. 296–304. On the callibration of the oscillators, see also Antonio Rodà, «Evolution of the Technical means of the Studio di Fonologia Musicale», in *The Studio di Fonologia. A Musical Journey 1954–1983*, cit., pp. 33–81.



Figure 1: Panel with the nine oscillators (third and fourth frame in the centre); Studio di Fonologia Musicale, 1956 (Photo courtesy of RAI).

	Scale					
	1	2	3	4	5	6
1	60	80	100	160	200	300
2	200	280	340	480	500	680
3	400	460	560	600	800	960
4	760	860	940	1000	1200	1300
5	1650	1100	1200	1180	1400	1450
6	1400	1400	1600	1800	2000	2200
7	2000	2400	2800	3000	2400	4000
8	4600	5000	6000	7000	8000	10000
9	50	100	400	1000	3000	7000

Figure 2: Calibration table of the nine oscillators, manuscript by Alfredo Lietti (Archive of the Studio di Fonologia, Milano).

Figure 2 shows a first calibration table prepared by the engineer Alfredo Lietti, who had been responsible for the first electronic devices at the Studio. The frequency ratios were later changed by Berio and Maderna in a less rigid way, following a musical logic rather than a technical one. One of the earliest documents relating to this new setting of the oscillators is a drawing of almost maniacal precision elaborated by Cage in 1958 during his stay at the Studio di Fonologia, where he was realising *Fontana Mix* (Figure 3).

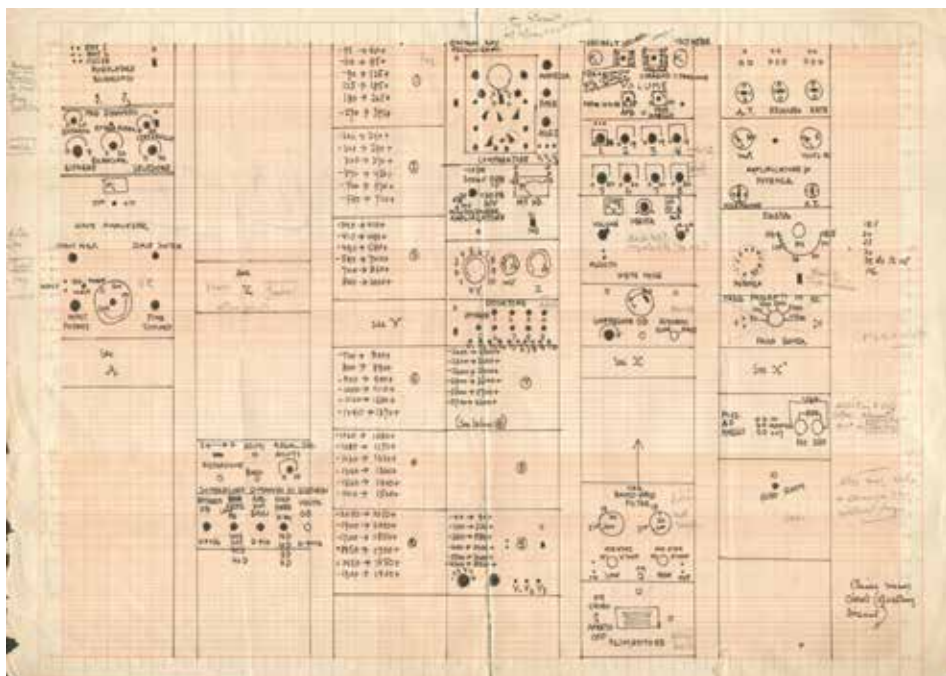

Figure 3: John Cage, drawing on millimetre paper of the equipment at the Studio di Fonologia della RAI in Milan (Archive of the Studio di Fonologia, Milano).

The drawing lacks any information about the eighth oscillator, however, this information can be supplemented with other archival documents.¹³ The following schematic shows all the frequencies that could be produced by the oscillators (Figure 4).

13 Among which is a letter from Berio to Henri Pousseur of 25 January 1957 (Paul Sacher Stiftung, Sammlung Henri Pousseur), and a letter from Alfredo Lietti to Vladimir Ussachevsky of 28 September 1959 (Archivio Studio di Fonologia, Fondo Lietti); cf. also «Riflessi del suono elettronico», cit., p. 300 and p. 330.

Oscillatore	Posizione					
	1	2	3	4	5	6
I	40 - 60	60 - 85	90 - 125	125 - 185	180 - 265	270 - 395
II	200 - 240	240 - 290	300 - 370	370 - 450	460 - 570	580 - 720
III	340 - 410	410 - 490	490 - 580	590 - 700	700 - 820	840 - 1.000
IV	720 - 800	800 - 890	900 - 990	1.000 - 1.110	1.120 - 1.230	1.240 - 1.370
V	1.020 - 1.080	1.080 - 1.150	1.160 - 1.230	1.240 - 1.320	1.320 - 1.400	1.410 - 1.500
VI	1.300 - 1.400	1.450 - 1.550	1.550 - 1700	1.700 - 1.850	1.900 - 2.050	2.050 - 2.250
VII	2.000 - 2.300	2.300 - 2.600	2.600 - 2.900	2.900 - 3.300	3.300 - 3.700	3.700 - 4.200
VIII	4.200-4.900	4.900-5.700	5.700-6.500	6.500-7.500	7.500-8.700	8.700-10.100
IX	40 - 90	100 - 220	250 - 550	600 - 1.400	1.500 - 3.600	4.000 - 8.500

Oscillatore	Posizione					
	1	2	3	4	5	6
I	Re [#] ₀ -La [#] ₀	La [#] ₀ -Mi [#] ₁	Fa ₁ -Si ₁	Si ₁ -Fa [#] ₂	Fa ₂ -Do ₃	Do ₃ -Sol ₃
II	Sol ₂ -Sib ₂	Sib ₂ -Reb ₃	Re ₃ -Fa [#] ₃	Fa [#] ₃ -La ₃	Sib ₃ -Reb ₄	Reb ₄ -Fa ₄
III	Fa ₃ -Lab ₃	Lab ₃ -Si ₃	Si ₃ -Re ₄	Re ⁺ ₄ -Fa ⁺ ₄	Fa ⁺ ₄ -Sol [#] ₄	Sol [#] ₄ -Si [#] ₄
IV	Fa ₄ -Sol ₄	Sol ₄ -La ₄	La ₄ -Si ₄	Si ₄ -Do [#] ₅	Do [#] ₅ -Re [#] ₅	Re [#] ₅ -Mi [#] ₅
V	Do ₅ -Do ₅	Do ₅ -Reb ₅	Re ₅ -Re ₅	Re [#] ₅ -Mi ₅	Mi ₅ -Fa ₅	Fa ₅ -Solb ₅
VI	Mi ₅ -Fa ₅	Fa ₅ -Solb ₅	Solb ₅ -Sol [#] ₅	Sol [#] ₅ -La [#] ₅	La [#] ₅ -Do ₆	Do ₆ -Do [#] ₆
VII	Si ₅ -Reb ₆	Reb ₆ -Mi ₆	Mi ₆ -Fa ₆	Fa ₆ -Sol [#] ₆	Sol [#] ₆ -La [#] ₆	La [#] ₆ -Do ₇
VIII	Do ₇ -Do [#] ₇	Do [#] ₇ -Re [#] ₇	Re [#] ₇ -Sol [#] ₇	Sol [#] ₇ -La [#] ₇	La [#] ₇ -Do [#] ₈	Do [#] ₈ -Re [#] ₈
IX	Re [#] ₀ -Fa ₁	Sol ₁ -La ₂	Si ₂ -Do [#] ₄	Re ₄ -Fa ₅	Solb ₅ -La ₆	Si ₆ -Dobb ₇

Figure 4: Frequency bands to which the nine oscillators were calibrated.

So far, these are merely plain numbers... I therefore tried to «translate» these numbers into pitches and notes, which provided me with a key information on the conceptual outfit of the Milan Studio di Fonologia (Figure 5).

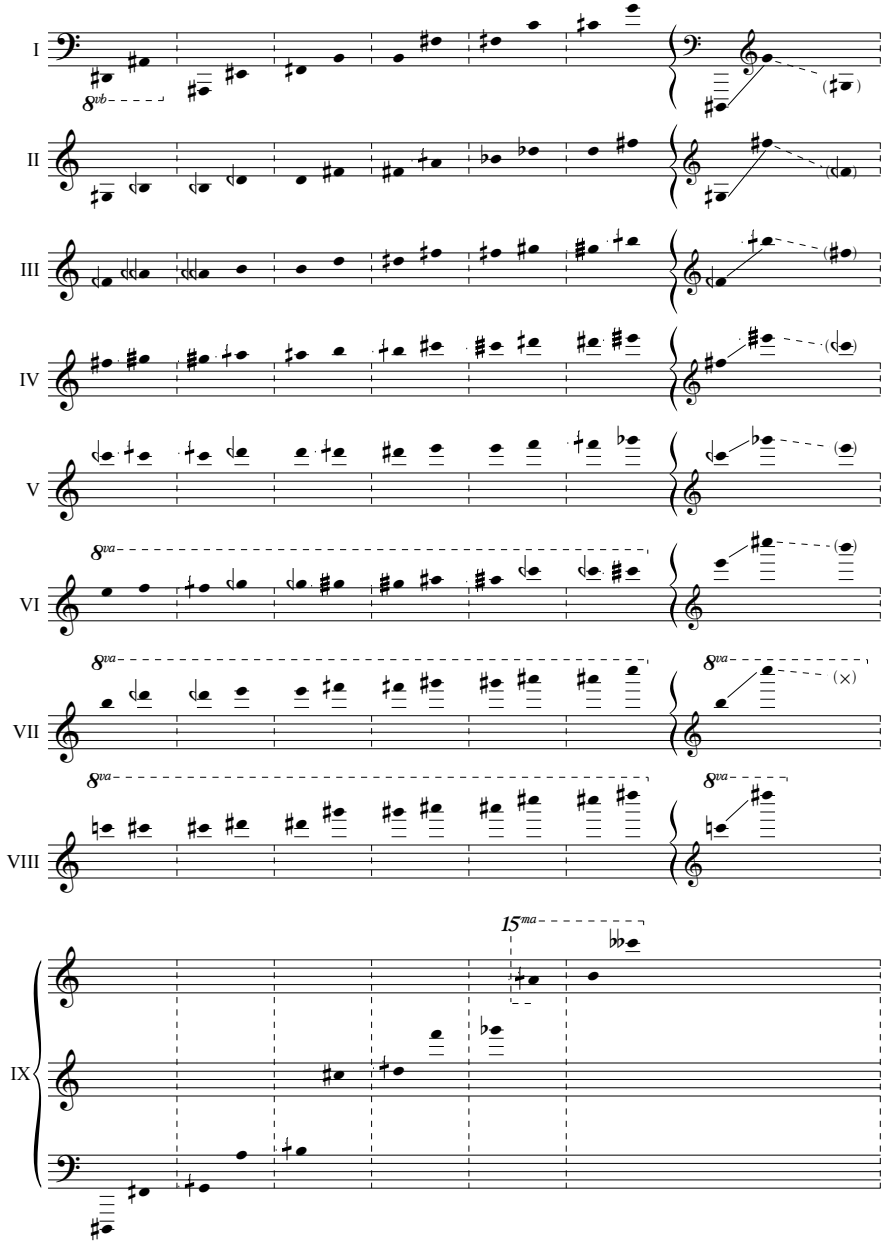

Figure 5: Transcription in traditional notation of the frequency bands generated by the nine oscillators.

In order to «master» the medium through experience that they previously gained in traditional music, Berio and Maderna *assimilate* their electronic instruments *conceptually* to traditional instruments. Much like the strings of an instrument, each oscillator is tuned to certain tones in order for it to be able to produce a minimal and a maximal pitch scale. The criteria seem to be drawn from the «orchestra»: each oscillator provides the composer with a frequency range corresponding to the different ranges of the instruments (the first to eighth oscillators cover the range from bass tuba to piccolo flutes, the ninth likely corresponds to the piano). The interval relations, although within the infinite variety and multitude of micro frequencies, seem «familiar» to a classically trained musician: the tuning corresponds to a pseudo-tempered principle, progressing in fifths in the first oscillator, in major thirds in the second, in minor thirds in the third, in increasingly smaller seconds in the fourth to seventh; the eighth oscillator is reserved for very high frequencies. In the ninth oscillator, the pitches are, from the lowest to the highest tone, laid out more or less according to a «diminished octave» system.

This shows that the device, before dictating conditions, was itself subjected to conditions that are by no means neutral. One therefore has to consider a possible implied complicity between the composer and the technical instruments, because, while technology has changed the conceptual horizon of composers, it cannot be denied that the same composers have actively interfered with the conditions of this change.

But let's return to the Studio, its frequency generators and composition methods (which are those then used by Maderna to compose his *Notturmo*).

The «construction» of a sound could be achieved in two ways, through additive synthesis (by either adding different fundamentals until one obtained a «timbre» or a complex sound), or through subtractive synthesis, starting with a noise generator and producing less complex sounds through filtering. The sounds thus selected were then integrated into the different components and «composed in» by means of specially designed modulation instruments. Complex timbres were produced through successive recording phases, the result was processed with various modulators: amplitude, frequency and ring modulators, echo chambers, amplifiers, speed modulators, amplitude discriminators, multitrack tape machines, impulse generators and so forth.

Prepared, isolated and segmented into separate events, the result thus achieved was finally arranged in a lengthy montage process. Thus, the composition evolved within a slow *process* out of the sum of the separate manual steps of mixing, cutting, splicing, montage and synchronising, in phases that were again and again directly listened to, compared and selected.

All that we have now mentioned (including the approach meandering between technology and intuition) can be found in *Notturmo*, a monophonic piece from 1956 with a duration of only 3'25", which was to mark the beginning of the Studio di

Fonologia's greatest period. *Notturmo* was composed almost simultaneously with Berio's *Mutazioni*, and the public response to these two works at the time was remarkable: It was not by accident that, in July of 1956, at the «Kompositorische Möglichkeiten der elektronischen Musik» (Compositional Possibilities of Electronic Music) meeting Maderna presented *Notturmo* and *Mutazioni* to «officially» introduce the Studio di Fonologia to the international scene present at the Darmstadt Summer Courses. That same year, the two electronic works were published on record as part of an edition of the journal *Elettronica*, which was exclusively devoted to the Studio di Fonologia (Figure 6). In the same journal a single page of the «technical score» for *Notturmo* was printed, which is a very important source for reflection and analysis (Figure 7).



Figure 6: Record attached to the journal *Elettronica* (V/3, 1956), which included, among others, Maderna's *Notturmo* and Berio's *Mutazioni*.

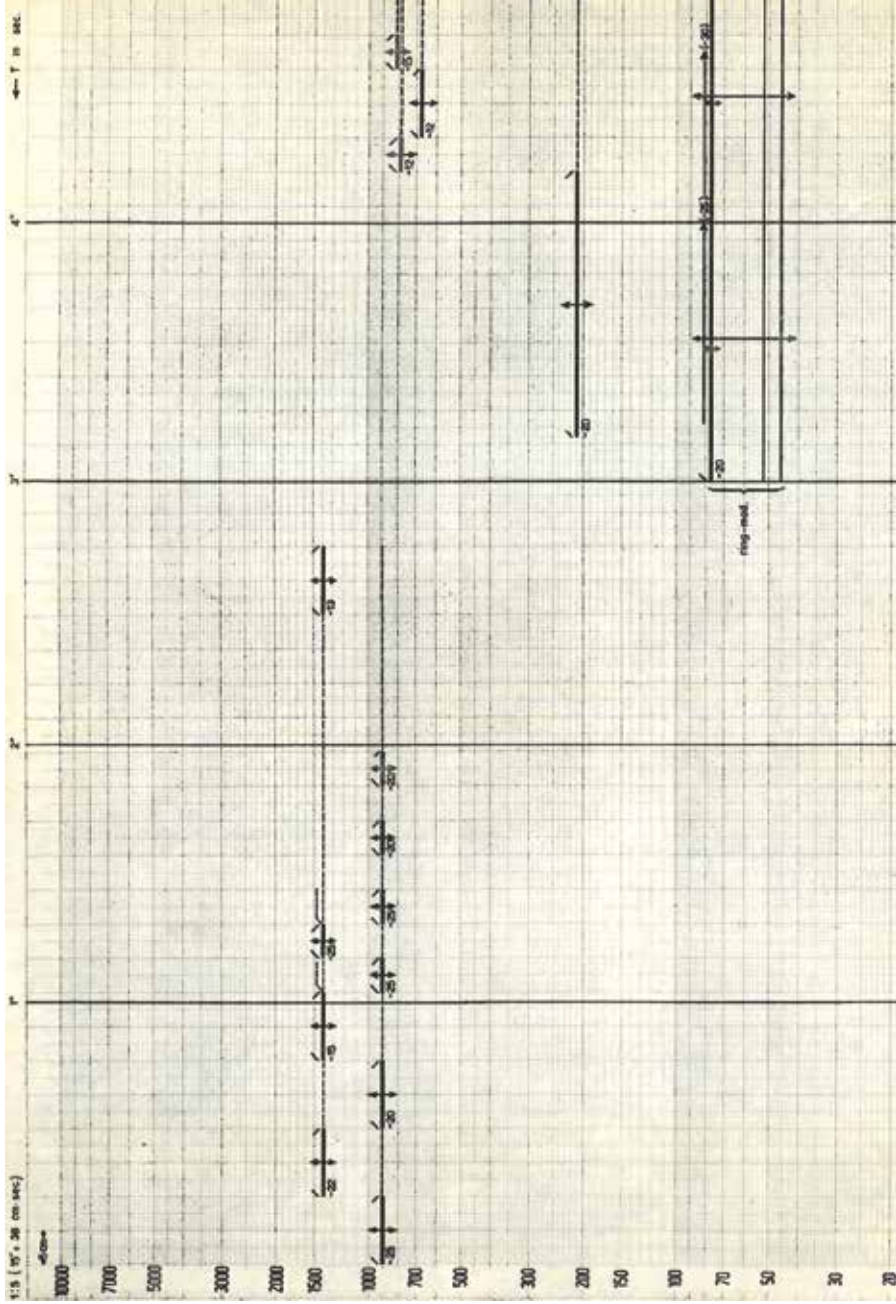

Figure 7: «First page of the score for *Notturno* by Bruno Maderna, in *Electronica*, V/3, 1956, p. 114.

Before taking a closer look at the score, I would like to present *Notturmo* in Maderna's own words, stemming from two different occasions: the first from the abovementioned conference in Darmstadt in 1957, the second from a handwritten note probably written for a conference in the same year. In Darmstadt, where Maderna was presenting the work to fellow composers, he concentrated mainly on technical aspects:

Notturmo was realized in the spring of 1956 at the studio of the Milan radio. It uses sinus tones and white noise filtered in different bandwidths and in different medium pitches. The smallest bandwidth, approximately 2 Hertz, gives an almost instrumental impression; it more or less resembles a flute. This suggests a possibility of a continuous linking of natural sound production and electronic means.¹⁴

In the handwritten note, Maderna offers more of an inside story about *Notturmo* and the beginnings at the Studio di Fonologia, also mentioning the duration of preparatory work at the Studio:

When in 1954 Luciano Berio and I succeeded in creating the Studio di Fonologia at RAI in Milan we certainly didn't think of the endless difficulties and problems we were to cause within the highly bureaucratic structure of the Italian broadcasting system ... Finally, some rather serious works could be produced almost in secrecy. I still remember the first works, they were simple but tiresome [to realise] and their realisation was accompanied by countless doubts: Berio's *Mutazioni* and my *Notturmo*.

Notturmo was my first purely electronic piece, composed only of frequency groups, white noise, different mixes. It was realized mainly at night and in secrecy with the help of the technician [Marino Zuccheri], who had already then become a very good friend of mine, because I only had very little time – officially, I had to be finished within a week –, but also because it was impossible to use the devices during normal daytime operations, when they were used for realizing smaller and larger pieces [for broadcast programmes] on short notice. When we had finished towards four o'clock and were completely exhausted, the technician and I jokingly decided to call the piece *Notturmo*, commemorating the lost hours of sleep. When I listened to it later I found that it did indeed have a nocturnal character. Therefore, I decided in earnest to keep the title.¹⁵

14 Bruno Maderna, *Kompositorische Erfahrungen mit der elektronischen Musik*, cit. (cf. also *Bruno Maderna. Documenti*, cit., p. 84).

15 Handwritten note by Maderna (two pages written in pencil, originally in Italian), conjectural date: 1957 (Paul Sacher Stiftung, Sammlung Bruno Maderna, folder «Aufzeichnungen, Vorträge, Notizen»).

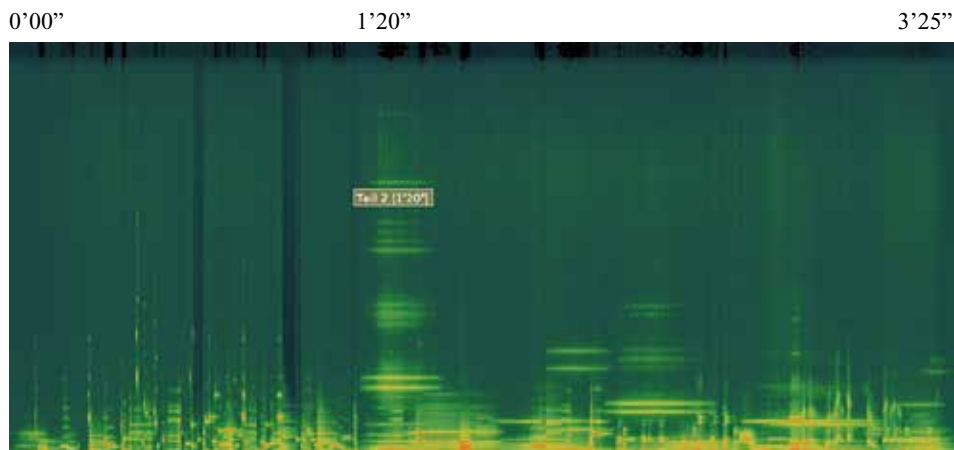

Figure 8: Spectrogram of *Notturmo*.

As the spectrogram shows (Figure 8), *Notturmo* consists of two parts (0'–1'20'' // 1'20''–3'25''), in which Maderna puts into practice various techniques of electronic composition. The first part consists mainly of narrowly filtered sounds that are combined to form figurative elements, some of which are based on traditional intervals. These elements (among them the trill) are repeated several times and subjected to different technical processes (for example changing of the tape speed, reverb, and reverse playback). Each technical processing step corresponds to a new type of sound. The second part contains a structure made up of five sound bands produced by ring modulation to which are added different elements.¹⁶ As we have heard, these complex timbres of the sound bands clearly contrast the pure sinus sounds. Whereas in the first part Maderna carefully puts together the elements one by one, in the second part he uses instead superposition and the playful dissolution of the sound bands. Put differently: the first part is designed like a sort of broken polyphony, consisting of different figures that reappear several times; the second part is made up of a progressive transformation of the sound material into which some elements already heard in the first part are inserted. As Nicola Scaldaferrri points out:

In both parts, the different elements correspond to the tape segments; they were precisely put together, so as to minimize the process of sound layering. Horizontal montage is preferred to sound mixing, which works vertically. Apart from economizing the work time this also allowed to keep tape noise, which would become louder with each copied layer, under control.

16 For more information on the genesis and analysis of *Notturmo*, cf. Nicola Scaldaferrri, «De l'événement sonore au processus de composition. Analyse de «Notturmo»», in *à Bruno Maderna*, vol. II, cit. (note 1), pp. 449–485; see also Id., «Montage und Synchronisation: Ein neues musikalisches Denken in der Musik von Luciano Berio und Bruno Maderna», in *Elektroakustische Musik. Handbuch der Musik im 20. Jahrhundert*, ed. Elena Ungeheuer, Band 5, Laaber, Laaber-Verlag, 2002, pp. 66–82.

Zuccheri¹⁷ claimed that the main activity of composers working at the studio at the time was to daily battle tape noise, especially in monophonic pieces where everything had to end up on one track. Because of the background noise, compositional strategies were defined in order to avoid tape noise – a pragmatic correlation that is clearly evident in *Notturmo*.¹⁸

As the listening example may have already made clear, Maderna in *Notturmo* organises the sound materials according to a (or searching for a) «conversation-like» character, which totally sets the piece apart from other electroacoustic works of the time. Even more unusual is the existence of the abovementioned page from the work's technical score (Figure 6), with which I want to finish my contribution.

There are almost no sketches or documents on the preparation of works realised at the *Studio di Fonologia*. This page is therefore a document of enormous significance, enabling us to acquire a deeper understanding of some of the technical processes Maderna used in realising the tape. Let us take a closer look at this page: the frequency ranges are marked on the vertical *y* axis on the left on a logarithmic scale (from 0 to 10.000 Hz). Above, on the horizontal *x* axis, the time is indicated in seconds (the page thus shows the first 5 seconds). Considering that the tape speed was 38 cm per second, this page is thus 190 cm long on tape. The millimetre paper also shows very well the exact length of the tape segments (or the musical events) in centimetres. On the top left, we can read that each box has a duration of «5 cm» (scale = 1:5), we can therefore see that the first sound «requires» 10 cm of tape.

Another important information we owe to this score relates to the cutting typology of the tape, which is here notated with a slash. This signifies that the cut was not straight but diagonal, a specialty used during the montage phase, allowing for a gradual transition from one sound to another (a straight cut, on the other hand, produces a clearly audible impulse sound at the joints). In the first 3 seconds two very narrow bands of filtered white noise are used, the first with approximately 900 Hz, the second with approximately 1400 Hz (the arrow indicates that the frequency may randomly oscillate to the indicated frequency). The acoustic result of this filtered oscillating noise is a timbre, which, as Maderna himself pointed out, strongly resembles that of a flute.¹⁹ Between the sounds marked by a continuous line (with a very narrow band) we can see dotted lines: these indicate the reverb effect of the preceding sound, which is recorded on a second tape and then mounted together with the first on which the original sound signal was recorded. At 4', then, a complex sound is notated, which has been produced with a ring modulator and which is overlaid by a narrow band of 220 Hz. So let us listen to these first five seconds of *Notturmo* by reading in the same time from this page of the score (see Figure 7).

17 Marino Zuccheri, the sound technician who had prepared the tape of *Notturmo* together with Maderna.

18 Nicola Scaldaferrri, «Montage und Synchronisation», cit., p. 70.

19 See above, note 14.

When the individual sound events were realised and recorded onto tape, the montage process began, a most important moment in electronic composition. It was a manual approach through and through, and the most important tools were scissors and splicing tape (Figure 8 shows Berio and Maderna next to a table with several tape segments before the montage). For the realisation of complex sounds, individual sounds were superimposed; they would be played back on two tape machines and recorded by a third. It was possible to produce very complex sounds through successive copying-recording operations. On the page of the score (Figure 7), everything is essentially indicated very precisely (sometimes even too precisely), but there is almost no reference to the montage processes, the practical steps that could not be expressed by any conventional signs. This gap is unsettling: how is this document to be interpreted? As a prescriptive draft, made by the composer before he worked out the tape (that is: the work), which should therefore be read as a series of steps within a work process that should allow a repeated «performance» of the work, much like traditional scores? Or is this rather a document written *after* the fact (or descriptive), a visualisation of steps already realised, which could only partially be put down in writing? Finally, one has to ask how it can be that, although the score is so precisely written, the duration of sound events on the tape and on paper do not exactly match. What we see on the first page should correspond to the first five seconds of the work; however, when listening, it corresponds to the first eight seconds...

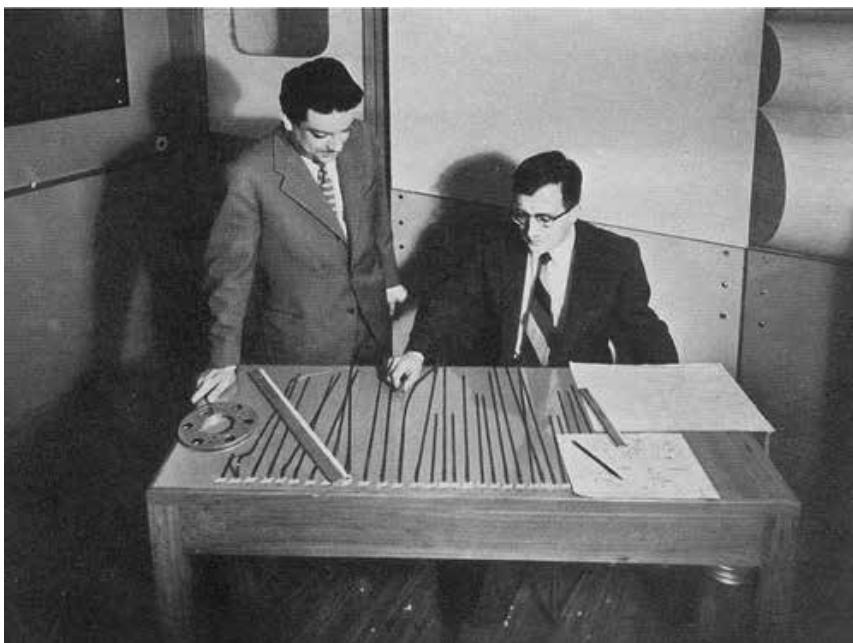

Figure 9: Bruno Maderna and Luciano Berio at the Studio di Fonologia, ca. 1955 (RAI Archives).

First, we should not forget that only this one first page of this «technical score» for *Notturmo* exists, which was published in the magazine *Electronica* together with a single page of the «technical score» for Berio's *Mutazioni* on the front cover.²⁰ In 2000, I had the opportunity to talk with Luciano Berio about these two pages and to ask him why there were only these two first pages while the rest couldn't be found anywhere. He answered that there was «always only the first page» of scores of electronic music, because they are made at the end of the composition process, where «there never was any time to write a complete score on the basis of my notes».²¹ The knowledge that this page was written only afterwards – for demonstration purposes – and did not act as a guide during the realisation process does not in the least reduce its significance, however. Without it, some technical processes used by Maderna in the realisation of the *Notturmo* tape would not be comprehensible.

Much could still be said about this work if one were to study its technical aspects more closely. However, in this context, this would perhaps not be very fruitful. After all that has been said, it is possibly more important to listen to the whole piece, paying special attention to the difference between the two parts, each conceived by Maderna with their own characteristics with respect to the elements used as well as to the technical processes applied. The repetition of the different elements, their constant permutation and variation, is a fundamental aspect not only of *Notturmo*, but of all of Maderna's electronic music. It is precisely this constant variation of the same material that allows the creation of a great variety of sounds while remaining within a coherent system and, as in traditional music, building on a logic of recognisability and the partial fulfilment of listeners' expectations.

After *Notturmo*, Maderna used the same mechanism of «continuous variation» in the works he subsequently composed at the Milan Studio (among others *Syntaxis*, *Continuo*, the new version of *Musica su due dimensioni*, as well as *Invenzioni su una voce*, *Serenata III* and so on), but also in his next instrumental compositions. In the course of the 1960s, working with tape became an integral part of his compositional practice, a flexible and indefinitely controllable device besides traditional instruments. Later, Maderna was also to use electronics in stage or orchestral works such as *Hyperion* or *Ausstrahlung*. The electronic sounds became for composers like him and Berio one material among many at the composer's disposition. A means, which, to use Berio's own words, is nothing but «what one makes of it»: a means that each time «has to be reinvented anew.»²²

20 See the reproduction in the chapter by Veniero Rizzardi in this volume (Figure 1, p. 44.).

21 Cf. «A Conversation with Luciano Berio», cit. (note 5), p. 166. See also the contribution of Veniero Rizzardi in this volume, pp. 43–62.

22 Luciano Berio, «Eroismo elettronico» (1972), in *Luciano Berio. Scritti sulla musica*, cit. (note 3), pp. 412–415: 413.

«There's always only the first page».
On the ambivalent relation between sound and notation
in some early electroacoustic music, and the problems
of modern editions

In 1956, the historical issue no. 3, year 5, of the otherwise strictly technical review *Elettronica* published by Edizioni Radio Italiana, had been entirely dedicated to the recently opened Studio di Fonologia Musicale. The cover illustration was a drawing on graph paper, and the caption described it as «a page of the score, notated for electronic music, of *Mutazioni* by Luciano Berio» (Figure 1). «In the lower part [...]», the caption continued, «the very same page transcribed in conventional notation», with the observation – which shouldn't have been obvious at the time – that it was just an approximation, since musical notation can't correspond to non-tempered sounds. In the inner pages of the review, another similar illustration showed the first page of *Notturmo* by Bruno Maderna.¹

Interviewed more than 40 years later about his and Maderna's score, Luciano Berio commented: «There is always only the first page, because there never was any time to write a complete score on the basis of my notes. But electronic music in the 50s and the 60s had no need of a score, unless there were conventional instruments involved. Only now I am completing the score for *Différences*, dated 1958!»²

Berio never realised this intention. And he had been thinking about it for more than 40 years. *Différences* is scored for five instruments; flute, clarinet, harp, viola and cello in dialogue with a tape part in which the same instrumental sounds reside, processed by means of different electroacoustic treatments, but always somehow recognisable, as if they were «hyper-instruments».

1 The piece is extensively discussed in Angela Ida De Benedictis, «The Beginnings of the Studio di Fonologia Musicale and Bruno Maderna's *Notturmo*», in this volume, pp. 25–41; the first page of the graphic score of *Notturmo* is reproduced there at p. 36 in Figure 7.

2 Angela Ida De Benedictis and Veniero Rizzardi, «A Conversation with Luciano Berio», in *New Music on the Radio. Experiences at the Studio di Fonologia of the RAI. Milan 1954–1959*, ed. Angela Ida De Benedictis and Veniero Rizzardi, Roma, Cidim-Amic / Rai-Eri, 2000, p. 166.

ELETTRONICA

EDIZIONI RADIO ITALIANA - ANNO V - 1° TRIMESTRE - 1956 - NUMERO 3 - L. 300

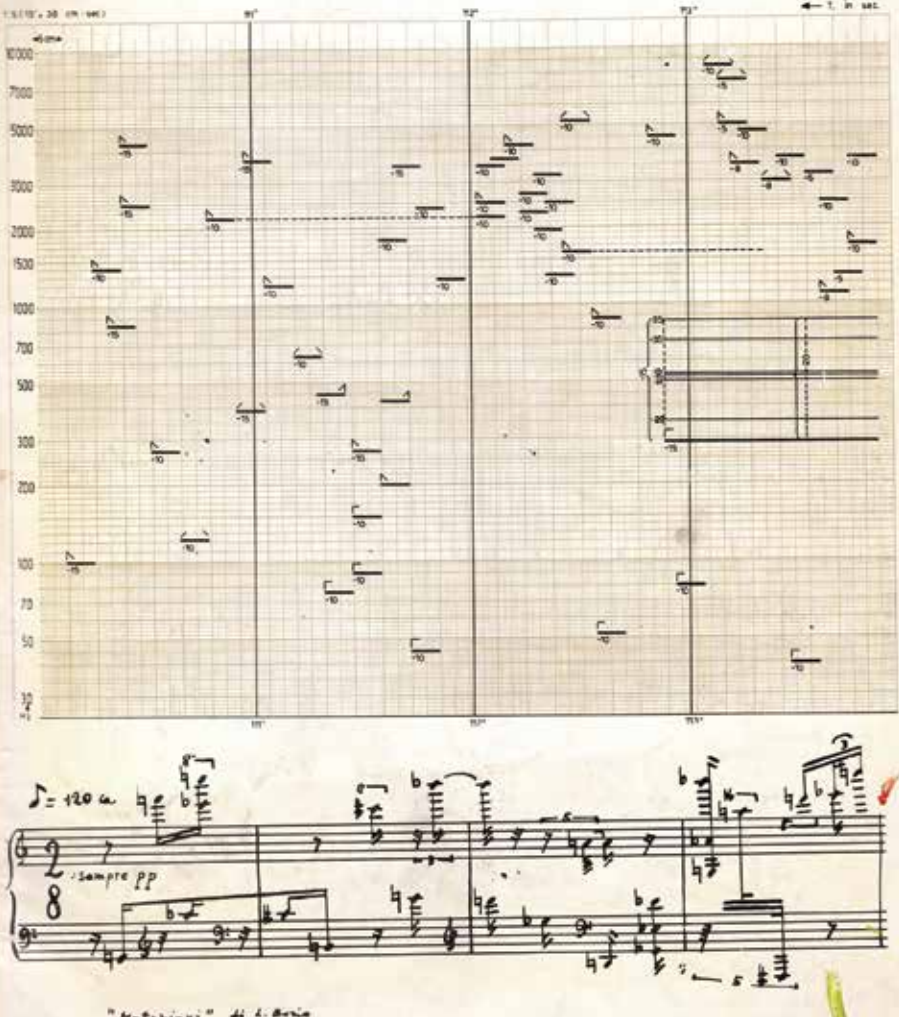

The image displays a spectrogram and a handwritten musical score. The spectrogram, at the top, is plotted on a grid with a logarithmic vertical axis labeled 'Hz' ranging from 20 to 10000 and a horizontal axis labeled 'T. in sec.' with markers at 0'', 1'', and 2''. The plot shows various frequency components over time, with a dashed horizontal line at approximately 2000 Hz. Below the spectrogram is a handwritten musical score for piano. The score is in 2/8 time with a tempo marking of $\text{♩} = 120 a$. It features complex rhythmic patterns and dynamic markings such as *pp* and *ppp*. The title "Mutazioni" by L. Berio is written at the bottom of the score.

Figure 1: First page of the score for *Mutazioni* by Luciano Berio, in *Elettronica*, V/3, 1956, cover page.

A score of the piece was posthumously published in the edition prepared by Francesco Giomi and Kilian Schwoon, two of Berio's closest collaborators at the Tempo Reale studio in Florence. Indeed, Berio had been working on that score since the early 1960s: a very long, although many times interrupted, process of revision is evidenced by the sheer quantity of manuscripts found in his estate pertaining to that work.³ Berio had also considered, among other variants, writing a new score and related instrumental parts for the music to be recorded and subsequently treated with a view to a remake of the tape. There may be several reasons for this – including of course the composer's wish just to make some changes – but one of the reasons may be found in a feature of the original tape, which is apparent especially in modern performances. These, indeed, are likely to reveal a noticeable distance between the styles of instrumental playing today and at the time of the preparation of tape (1959), e.g. with respect to vibrato or portamento. Regardless of the electroacoustic treatments, the more recognisable instrumental sounds of the tape inevitably bear the mark of time.

The argument of «lack of time» cited by Berio is less mundane than it appears. To write down the score of a work that is inherently complete as a sound artefact probably seemed like a pointless task, or something that would have had a different function than a conventional score. Those notations on graph paper with accurate indications of frequencies, durations and waveforms were almost a visual complement to the actual work, a demonstration of the novelty and diversity inherent in electroacoustic composition. They were also most probably drawn only after the realisation of the pieces of music. The elaboration of early musical artefacts such as *Notturmo*, or *Mutazioni* certainly required accurate planning of the instructions for operating on the sound generators and processors, but a great part of the creative process took place within the interaction of design and practical realisation – almost as a compositional «performance».

On several occasions Luigi Nono has recalled how frustrating his first experience at the studio had been, when he came with «an acoustic graph <thoroughly> prepared [in advance]», which, after an elaborate procedure, yielded a poor-sounding, meaningless result. He soon had to realise that the composer must relate to the new instruments not as if they were merely passive tools and that a musical project involving electronics could not be defined on the basis of an abstract calculation. The sound matter, although produced in precisely measurable quantities, also had a life of its own, so to speak, as compared to the compositional intention.⁴

3 The manuscripts are now part of the Luciano Berio Collection at the Paul Sacher Stiftung in Basel. I am indebted to its curator, Angela Ida De Benedictis, for all the information about the history of Berio's struggling with the edition of *Différences*.

4 «For some hours we worked on the creation of an acoustic graph, <thoroughly> prepared by me in Venice. It involved several relationships between sinusoidal frequencies, with precise centimetre-duration measurements with varied attacks and intensities. The result

It would be years before Luigi Nono made a similar experience, something which was common among composers who, at that time, approached the electronic medium as an instrument fitted to the new musical thought, based as it was on the factorisation of so-called musical parameters – while, instead, it was precisely the contact with that medium that was to reveal a new dimension in the creation of sound, that is, something that went beyond the supposed predictability of the sonic result achieved by following a calculated plan; and of course, the possibility to listen quickly, or immediately, to the result produced by a certain operation was to favour the discovery of potentially new sonic, and therefore musical, solutions to a given compositional problem.

Nono had been approaching electroacoustic composition since 1956, as is attested by several sketches in a book also containing precomposition materials for *Il canto sospeso* of the same year. The nature of these sketches links them to the failed project of a serial electroacoustic composition mentioned above. A more mature attempt along these lines yielded, in 1960, a piece entitled *Omaggio a Emilio Vedova*, which, however, remains an isolated experience because only four years later Nono would eventually find a personal and definite method of composing at the electroacoustic studio, and this would drive him to rethink the conception of the musical work, its notation and its performance practice.

The first step in this direction is the composition of *La fabbrica illuminata*, a spin-off of a more ambitious theatrical project, called *Un diario italiano* – where most probably the use of electroacoustic means had been considered – of which it should have been only a scene. It became instead a self-standing composition when Nono, motivated by having to collect field documentation of the working conditions in the factory, received what he liked to call a creative «provocation» once he found himself immersed in the environment of the steel plant. He then decided to use the impressive soundscape of the foundry, including the voices of the workers, as an orchestral apparatus surrounding a live solo female voice, with the addition of a speaking choir, also on tape.

This idea was realised through a process that recomposed the noise material in a way that would eschew mere descriptivism in favour of a purely sonic

was «something» almost insignificant and a tremendous *sganassada* [roaring laughter] for Marino [Zuccheri] and Bruno [Maderna]. First immediate lesson: the electronic studio did not require projects «preplanned» on the desk, but rather study – experimentation – *always listening in real time* at every moment with a devoted patience extending beyond «time», with a continuous deepening of possible and impossible-utopian musical ways of thinking and knowing [*pensari e saperi*], to arrive at *other* theoretical-practical and musical ways of thinking, including the use of space.» Luigi Nono, «For Marino Zuccheri», in *Nostalgia for the Future, Luigi Nono's Selected Writings and Interviews*, ed. Angela Ida De Benedictis and Veniero Rizzardi, Berkeley, University of California Press, 2018), p. 351.

Zuccheri himself recounted the incident in Angela Ida De Benedictis, «...at the Time of the Tubes... A Conversation with Marino Zuccheri», in *New Music on the Radio*, ed. Angela Ida De Benedictis and Veniero Rizzardi, cit., pp. 190–192.

dramaturgy, also articulated spatially: four speakers are required, placed at the corners of the listening space. At the same time Nono would develop a new conception of the electroacoustic material as a polyphonic arrangement of heterogeneous sound sources, more or less heavily processed, where an essential feature is the presence in the fixed media of the same voices that one would hear from the performer(s) in person.

The solo part originated in an experimental process in which the performer would improvise on a given poetic text and the composer would collect the resulting material both for inclusion in the concert tape and to be entrusted to the live performer in some notated form.

The part therefore resulted in a defined musical text, but its appearance on paper differed from notations that Nono had used before – that is, when the creative process was entirely confined to the sole experience of the composer himself, and ended up in meticulously notated instructions for the performer. The composition of the vocal part in this case was carried out in close contact with the performer, and a key factor in this process was the recording medium. A notation was generated in which there was no need to precisely define such elements as articulation and time itself (durations), which the original performer naturally knew, having been involved in the process, but which any other performer may find as well, keeping herself to the references on the tape, and matching her «double» on it.

There exists then another kind of notation which, in this case, the composer had devised for himself: it is the musical equivalent of a prompt book, an interesting example of a notational translation of an accomplished process that had been carried out in close contact with the sound material.⁵ In Nono's book a spatial four-part polyphony is described, in analogy to the four-track magnetic tape itself. Four parallel lines, in blue ink, run through a grid of minutes and seconds. The four tracks are numbered from top to bottom and include a fifth line, in red, not numbered, corresponding to the live vocal part, bearing the text and a few descriptions of the part. This vocal track is placed between tracks 1 and 2 – that is, at the centre of the front delimited by sound sources 1 (left) and 2 (right), while 3 and 4 correspond to rear-right and rear-left speakers, respectively (Figure 3).

5 In the critical edition of the score, this source is referred to as «M28». See Luigi Nono, *La fabbrica illuminata*, critical edition by Luca Cossettini, Milano, Ricordi, 2010, p. 44.

The image shows a handwritten musical score for the vocal parts of the opera *La fabbrica illuminata*. The score is organized into several systems, each with a time signature in minutes and seconds:

- System 1:** Time signature *a. 3'31"*. It features staves for Soprano (S), Alto (A), Tenor (T), and Bass (B), along with a Piano (P) part. The lyrics "NON SI FERMA" are written above the vocal staves. Dynamics include *pp* and *ppp*.
- System 2:** Time signature *a. 5'20" (COLATA)*. This section is titled "II PARTE: GIRO DEL LETTO". It continues the vocal lines and piano accompaniment. Dynamics include *pp* and *ppp*.
- System 3:** Time signature *a. 6'34"*. This section is also titled "II PARTE: GIRO DEL LETTO". It includes the lyrics "NON SI FERMA NO" and "BOCCA CAUSA". Dynamics range from *pp* to *ppp*.
- System 4:** This system continues the piano accompaniment with time signatures *03"*, *04"*, *08"*, *13"*, *18"*, and *21"*. The lyrics "BOCCA CAUSA" are present. Dynamics include *pp*, *mf*, and *ppp*.
- System 5:** This system continues the piano accompaniment with time signatures *a. 7'22"*, *26"*, *28"*, *44"*, *45"*, *47"*, *49"*, *51"*, *52"*, and *54"*. The lyrics "AGGRE-DI-DE" and "LEORE" are present. Dynamics include *ppp*, *sf*, and *pp*.

Figure 2: Excerpt from the vocal score of *La fabbrica illuminata* (minutes 3'31"–7'54"), first published in the author's manuscript, Milano, Ricordi, 1984; now reproduced in the critical ed., Milano, Ricordi, 2010, p. 33. Reproduced with kind permission of HAL LEONARD MGB S.R.L., Italy.

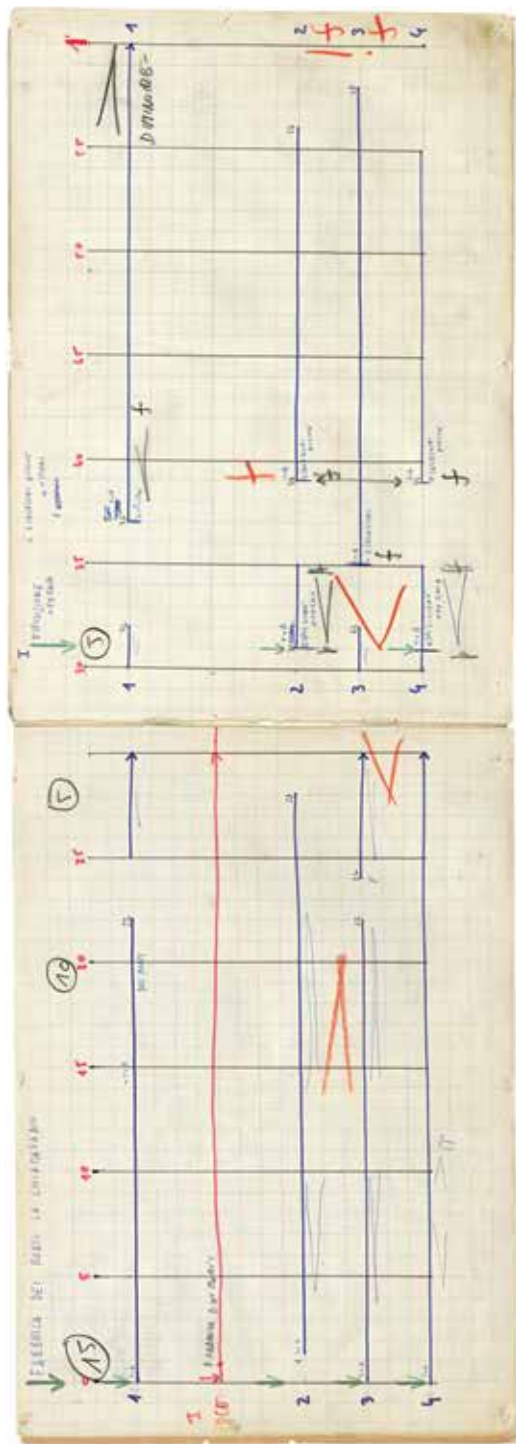

Figure 3: Excerpt from the tape score of *La fabbrica illuminata*, minutes 0'00"–0'30" (Archivio Luigi Nono (signature Q.17.002), reproduced with kind permission. © Heirs of Luigi Nono).

Above the lines some brief verbal descriptions of the sound events are traced, frequently expressed in characteristic studio parlance, tinged with the Venetian dialect shared by Nono and the technician Marino Zuccheri. These traits can also help to understand the origin of some of the sounds that had been processed, e.g. the words «porta», «vagoni» e «colata», bearing reference to specific noises of the steel plant (gate, waggon, casting). Sometimes these descriptions are interwoven with transcriptions of actual words uttered by the workers, thus providing additional context to what is heard. An episode of special interest in this sense is the crescendo leading to the *climax* of the piece, using processed sounds that prepare the «casting» moment. At 5'20" Nono writes «colata», which marks the beginning of the process ending at 6'45" with an 8-fs fortissimo, preceded by the excited voices of the workers («dai, dai») (Figures 4–5).

Information of this kind, however, was not meant to be public, the composer having decided to avoid any «naturalistic» or descriptive associations while composing and processing the sounds of the steel plant. Yet it provides a map of the work, which helps greatly to understand its polyphonic and spatial texture.

Apart from the description of the sound materials and their disposition in time and space, the tape score includes a further dimension, definitely pertaining to the sound projection. While the actual «score» is generally written with a ballpoint pen in a neat and uniform fashion, other signs look like they were added in a more excited and «expressive» manner using different writing tips. It is very likely that this level of information was added in view of a specific performance and possibly remained fixed, providing directions for further performances. Its nature is apparently more practice-oriented and aims at developing, specifying, or just stressing what the score already describes, especially dynamics. Actual additions are verbal instructions, sometimes jocular, for the sound projectionist, and indications in dB of the general sound level.

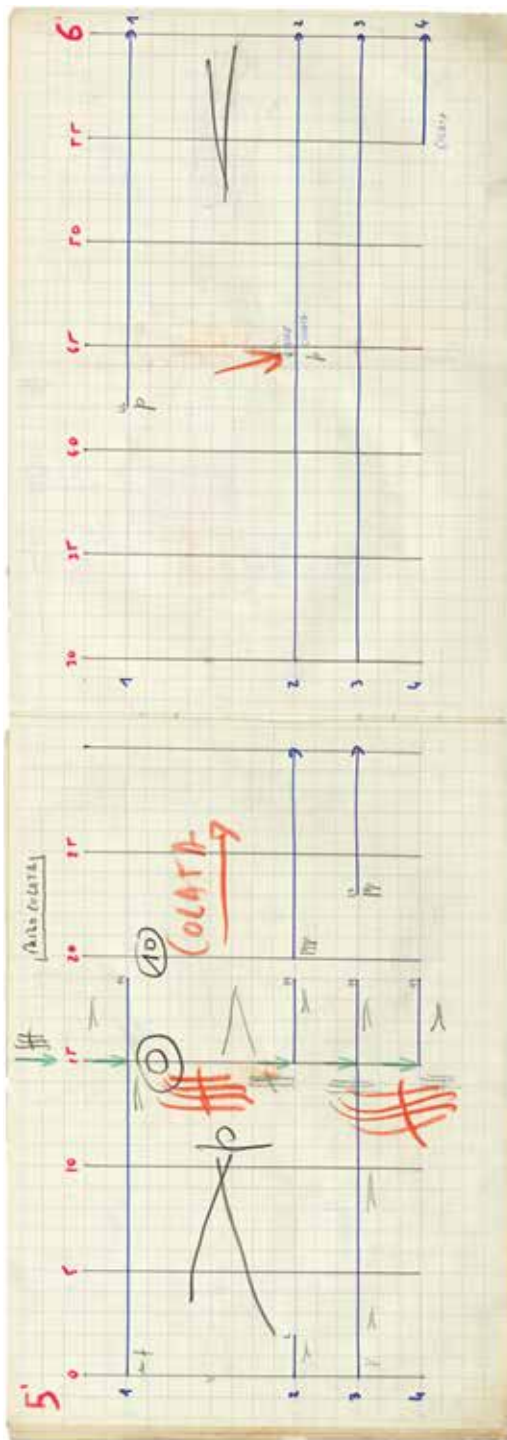

Figure 4: Excerpt from the tape score of *La fabbrica illuminata*, minutes 5'00"-6'00" (Archivio Luigi Nono (signature Q.17.009), reproduced with kind permission. © Heirs of Luigi Nono).

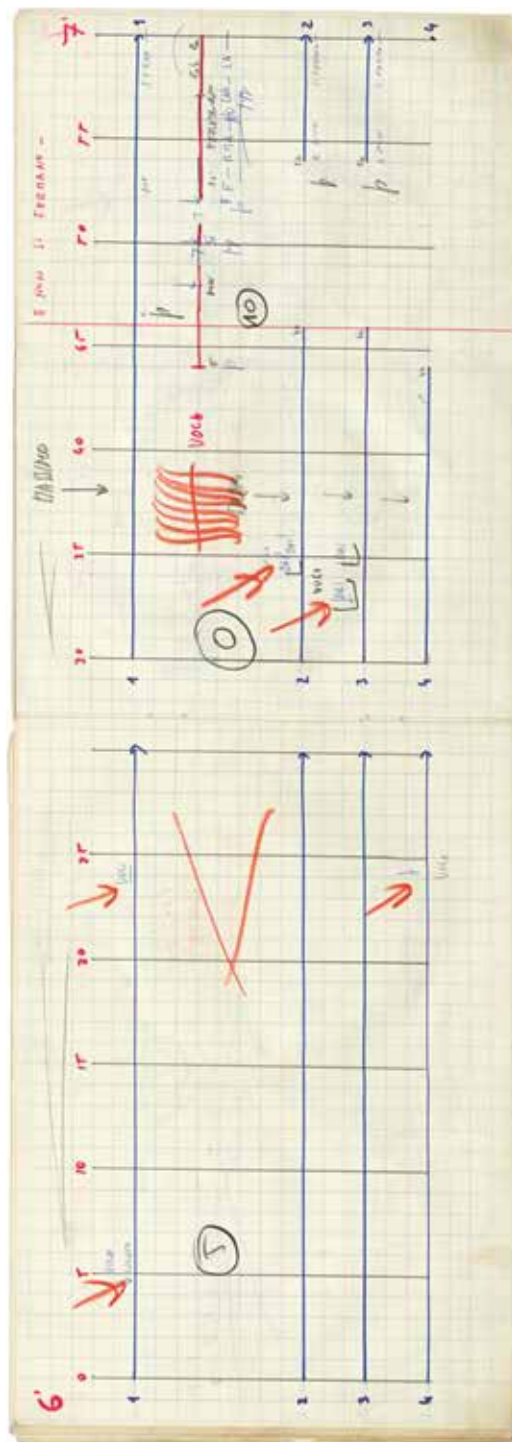

Figure 5: Excerpt from the tape score of *La fabbrica illuminata*, minutes 6'00''–7'00'' (Archivio Luigi Nono (signature Q.17.010), reproduced with kind permission. © Heirs of Luigi Nono).

A work such as *La fabbrica illuminata* therefore makes use of two different kinds of notation with different disposition and functions: there is a musical text, strictly instrumental to the vocal part, and the descriptive translation of an «acoustical text» (the sounds on tape), which serves as an instruction book for the projection. In both cases, the peculiarity of the notation has its roots in the fact that the creative process involved the performer in an active collaboration, and that the composer himself also plays an active part in the live performance.

The rather recent critical edition of the piece, which for many reasons is an outstanding scholarly endeavour, has decided to make use of this source only as «a means of understanding more of the rapport between the electronic medium and the voice»⁶ but not for any form of publication. The editor explains that it would have been a mistake to fuse this source with the main one (that is, Nono's vocal score) in order to give birth to a supposedly coordinated score, which would have put the vocal part in an all too rigid framework. This is certainly a point, but the editor's choice to underplay the tape score and to consider the vocal part the only possible score to the piece, however respectful of the author's intentions, is somehow limiting, since both the descriptive and the prescriptive elements of this source would greatly help the sound projectionist – not a mere «assistant», but a true performer – to understand the nature and the substance of the piece.

Looking back, *La fabbrica illuminata* in Nono's creative itinerary represents an important intermediate phase taking the direction towards a new format, which was to become typical of his electroacoustic compositions developed at the Milan Studio. A method of composing that characteristically gives the performer(s) more creative tasks will evolve in such a radical manner that the rendition of a specific piece would become problematic without the original performers.

The two following works do not show this type of problematic, as they basically reside on fixed media. In 1965 Nono composed the incidental music to *Die Ermittlung* by Peter Weiss, staged by Erwin Piscator, one of his last productions – also the only occasion for Nono to collaborate with a director who had been one of his reference artists when he began to imagine and explore new possibilities for musical theatre. The sound material for the *Ermittlung* tape is essentially vocal. The next composition, *Ricorda cosa ti hanno fatto in Auschwitz*, is a reordering of the *Die Ermittlung* music, and can be considered as sort of a «concert suite». Both tapes were realised in mono, encouraging the sound projectionist to move sounds freely in space, operating dynamically on four or more speakers.

The next piece, however, *A floresta é jovem e cheja de vida*, of 1966–7 marks a turning point in Nono's work with respect to compositional techniques and even more so the actual concept of a musical work. Broader in scope and dimensions than *La fabbrica illuminata*, *A floresta*, too, had been conceived as a theatrical project that eventually took shape as an oratorio of sorts. Composed for

6 Luigi Nono, *La fabbrica illuminata*, critical edition by Luca Cossettini, cit., p. XXV.

an ensemble consisting of four voices, clarinet, and percussion complex plus two four-track tapes to be played back on a p.a. system surrounding the audience, it realises a true acoustic dramaturgy with the movement of sound in space contrasting the stark presence of the live performers. Here is Nono's concise description of materials and techniques employed in *A floresta*:

Composed between 1965 and 1966.

World premiere at the international festival of contemporary music of the 1966 Venice Biennale. Dedicated to the National Front for the Liberation of Vietnam.

Texts: compiled by Giovanni Pirelli.

a) «live» (voices: soprano Liliana Poli, actresses Kadigia Bove and Elena Vicini, actor Berto Troni): eleven moments of the anti-imperialist struggle, of reflection, of difficulty, of defeat, of lament, of conscience and of determination to continue the harsh and long struggle, of questioning.

b) texts composed on magnetic tapes (voices: Living Theatre, actresses Franca Piacentini and Enrica Minini, Kadigia Bove and Elena Vicini, soprano Liliana Poli): fragments from the appeal by the American committee for the cessation of the war in Vietnam, and of the «escalation» worked out in theory by Herman Kahn, American defence department military specialist.

Acoustic materials:

a) produced by new techniques by the American clarinetist William O. Smith.

b) vocalised by the voices and by the Living Theatre, collaborating in research according to the nature of the characteristic personal vocal qualities and in relation to the phonetic character of the texts in their original languages, and recorded with varied techniques, using mobile and stationary condenser microphones within the acoustically variable premises of the RAI in Milan.

c) derived from five copper plates of different thicknesses, also used «live».

d) electronic effects engineered by RAI Studio Milan.

The experimentation and selection of the materials were made in common research and critical analysis by all the participants, in relation both to their technical-acoustic quality and to the semantics of the texts. The subsequent elaboration and composition on tape (two four-track tapes) were effected in the RAI Studio di Fonologia in Milan, with the dedicated collaboration of the technician Marino Zuccheri.

The live portions, with the eleven movements, were composed with the close participation of the four voices and the clarinetist.⁷

While with *La fabbrica illuminata* a lot of the details stemmed from the improvisations of the first performer over some composed lines, there was hardly any precomposed material in the new work. The chosen texts⁸ were not set to music

7 Luigi Nono, *A floresta é jovem e cheja de vida* [score], ed. Maurizio Pisati and Veniero Rizzardi, Milano, Ricordi, 1998, pp. XXXVI–XXXVII.

8 The first selection of the texts was made by Giovanni Pirelli among a vast collection of quotes taken from statements or letters by workers, students, political leaders, all militants of the

beforehand, not even in a sketchy fashion, but were left entirely open to the creative contribution of three actors and a singer.

As one of the actresses involved recalls,

Nono [in a first phase of the work] began by selecting voices that were to start off with their minds in a «virgin» state and be able to confront and interpret poetic or documentary texts without taking account of the naturalistic code of routine theatrical technique. Such were the terms on which he offered us poems by Cesare Pavese to interpret, for ex., or phrases taken from letters or documents coming from all over the world, provided that they had been written by people who had fought for freedom [...].⁹

The work therefore was shaped by the personality, the body of a given performer. This was to become typical for all of Nono's subsequent works, and in this respect there is indeed a substantial continuity from the vocal/electro-acoustical performances of the 1960s to the seemingly very different works with live electronics of the 1980s.

According to Nono's introductory text for the Venetian premiere of 1966,

two four-track tape recorders are required for the performance, with two differentiated sound sources: the first in front of the audience, the second around and behind it [...] The voices, the clarinet and the bronze sheets perform live in another acoustic dimension. In addition, the voices and the clarinet are amplified – microphones and loudspeakers; and the variable filter (one third of an octave) operates directly on them, dynamising them both spatially and in terms of their timbres.

While filters were eventually dropped during the rehearsals, it is still apparent that Nono had conceived a premature live electronic piece.

The experimentation involved essentially vocal sounds, a further step on the long road toward a completely new, reformulated way of *singing* that began in 1956 with *Il canto sospeso*.

The material for the tape was prepared in the course of some experimental sessions. Nono asked the vocal performers to react expressively to some texts he had selected according to the principles of phonetic and semantic fragmentation he had applied in earlier serial pieces and eventually theorised in the essay *Text-Music-Song*, dating from 1960.¹⁰ Besides the three actors, only one singer, strictly speaking, is involved, but even in this case Nono called for unusual techniques. Percussion instruments are custom-built bronze sheets of varying thickness and

«anti-imperialist struggle». Pirelli had already worked with Nono in 1956 at the selection of the text material for *Il canto sospeso*, taken from letters of European anti-fascist fighters sentenced to death during WWII.

9 Elena Vicini, [notes to] Luigi Nono, *A floresta è jovem e cheia de vida* [score], see above, note 7, XL.

10 Luigi Nono, «Text-Music-Song», in *Nostalgia for the Future, Luigi Nono's Collected Writings and Interviews*, ed. Angela Ida De Benedictis and Veniero Rizzardi, cit.

size, on which actions of rubbing and hitting are performed with the aid of industrial tools such as hammers, metal drills and chains. As for the solo clarinet, rather than the instrument, Nono had chosen the performer, William O. Smith, who had been first to develop new multiphonic techniques systematically on his instrument.

The second phase of the work consisted of the elaboration and definition of the live contributions. The group worked for days on end to shape the various parts into their definitive form. What Nono laid down for each contribution was: the signifiers of the individual phrases — the means of expression — the sound pitches. Each of us had to adapt the instructions we received to our own natural registers and develop them in accordance with our artistic temperaments. When an optimal result was reached, this was established as definitive. One could therefore say that in the end a score was engraved in our memories, and the margin of freedom it allowed was practically non-existent. This «oral» score was later definitively captured by the recording.

The third phase of work was done for the first performance. During the rehearsals in the theatre we had to establish the entries and the duration of the live contributions in relation to the recorded tape. We knew the tape fairly well, but it was very difficult to come in at exactly the right point on it, so we arranged that Nono would give us cues with luminous signals by means of little concealed lights at our feet on stage. The same system was adopted for the percussionists. And in front of us there were microphones which were regulated and sometimes switched off in an extemporary fashion by Nono himself assisted by Marino Zuccheri, the technician from the Studio di Fonologia who had followed the work's creation from its inception.¹¹

No score was ever written, and individual parts were written down by the performers only as a sort of shorthand. What the actress Vicini calls «oral score», and the clarinetist William O. Smith «sound script» was therefore a non-written musical «text», which had been imprinted into the memory of the performing group and had, according to their testimonies, permitted a number of performances equal to each other.¹² Nono was always the conductor – or, perhaps, the director – of the ensemble and also supervised the sound projection. After the tour that followed the 1966 premiere, the piece was recorded and published on an LP disc, and subsequently performed, from time to time, until a short final tour with four performances, including a TV production, ten years after the premiere. On these occasions, the cast remained the same except for the clarinetist, who was substituted twice, and whose part was reworked by Nono according to the specific abilities of the new players. The clarinet player, on the other hand, was free to improvise in some sections, and this is the only considerable variant to the «oral score» fixed in 1966.

11 Elena Vicini, [notes to] Luigi Nono, *A floresta è jovem e cheja de vida* [score], see above, note 7, XL–XLI.

12 Only the percussion group had a notated part because, for practical reasons, the six performers were not part of the touring group and were recruited on purpose every time.

It is worth noting that *A floresta* is the only work in Nono's catalogue in which the composer himself had been actively involved as a performer for such a long time. Nevertheless, the piece received no more performances in Nono's lifetime, a fact that he later explained by pointing out the work's particular constitution:

I was asked several times to resume *A floresta*, but I've said «no», because it would be necessary to choose new voices, work with them at least for one month, discover new possibilities ... then I prefer writing a new piece. Apparently, this kind of attitude doesn't meet the needs of the market! Anyway, the record remains, and this is enough, even if it renders only 10% of the reality.¹³

Shortly after the composer's passing in 1990, at the insistence of numerous festivals, theatres and performers, the publisher decided to attempt an experimental reconstruction of a score from the extant sources known at the time, which were basically the «parts» of the five soloists and a tape score, or prompt book, as already described, analogous to the one that Nono had prepared for *La fabbrica illuminata*, however, much richer in information, and also harder to decipher, according to the greater number of tape tracks (eight versus four) and the references to the many live performers. The only clear notational information came from the percussion score mentioned earlier.

The task of substituting the «oral score» with a more conventional one proved almost impossible. Even the method of collating the written sources with recordings of the performances, especially the one commercially released as an LP disc, proved uncertain and hardly reliable, because in most cases it was hard to distinguish the very same voices and instrumental sounds appearing simultaneously on the concert tape and in the live parts.

The LP, however, revealed that Nono had dedicated great care to fix an optimal rendition of the work («Anyway the record remains, and this is enough»), which also ended up being the only complete performance that has been preserved.

In the meantime, the Luigi Nono Archive was established in 1994 and began operations. New sources emerged from the estate of the composer, particularly a collection of working tapes, among them some that were used for the production of the record.¹⁴ Two tapes were especially interesting; they contain the live parts alone, the voices and the clarinet on one tape, the percussion ensemble on another. This discovery also shed light on the actual method of producing the recorded

13 Philippe Albèra, «Entretien avec Luigi Nono», in *Luigi Nono – Festival d'Automne à Paris 1987*, Paris, Contrechamps, 1987, p. 19.

14 Two records were produced. A limited quantity of the first was printed for a small label in 1967 (Arcophon AC 6811) and contains the reference version, lasting 40'05". The second, produced in 1979 (Deutsche Grammophon 2531 004) had a far larger distribution, but for this production the piece underwent a cut of 7' 53" – probably for technical reasons, because *A floresta* was coupled with the premiere recording ofsofferte onde serene... for piano and tape. Neither of the two versions has so far been reissued on CD or sound file.

performance, which had been done by editing together elements recorded on separate tracks and/or, possibly, sessions. It was of course much easier to confront these tapes with the performers' «parts» than the overall sonic result on record and to realise that Nono had partly reordered the music on tape, especially the clarinet part – interestingly, the more freely improvised one – by cutting, splicing and even duplicating sections.

Starting from these elements, it was decided that at least a credible score could be assembled with the recorded performance as reference material, taking it as an «acoustical text» corresponding to the «oral score», also finished with compositional interventions in postproduction. All the elements necessary to establish a score were then available: two «prompt books» with a carefully drawn map of the content of the tapes, including directions for the sound projection and various references to the soloists' and the percussion parts (Figure 6); also an accurately written-out percussion score,¹⁵ and the individual parts that could eventually be better deciphered with the aid of their corresponding recordings and, most importantly, of the detailed recollections of the original performers, who were interviewed, individually and together.

Despite the fact that neither the composer nor the performers had ever needed a conventional score, Nono did indeed try, at the urge of his publisher, to write one, soon after the premiere. He stopped very soon – another telling case of «there is always only the first page» – but it was enough to provide a pattern for the posthumous edition, which was completed in 1998.¹⁶

15 Described respectively as «B1» and «QP3» in the Ricordi 1998 edition, p. XXXIV (see above, note 7). It is not surprising that the only carefully notated parts are those of the percussion. See above, note 12.

16 See above, note 7.

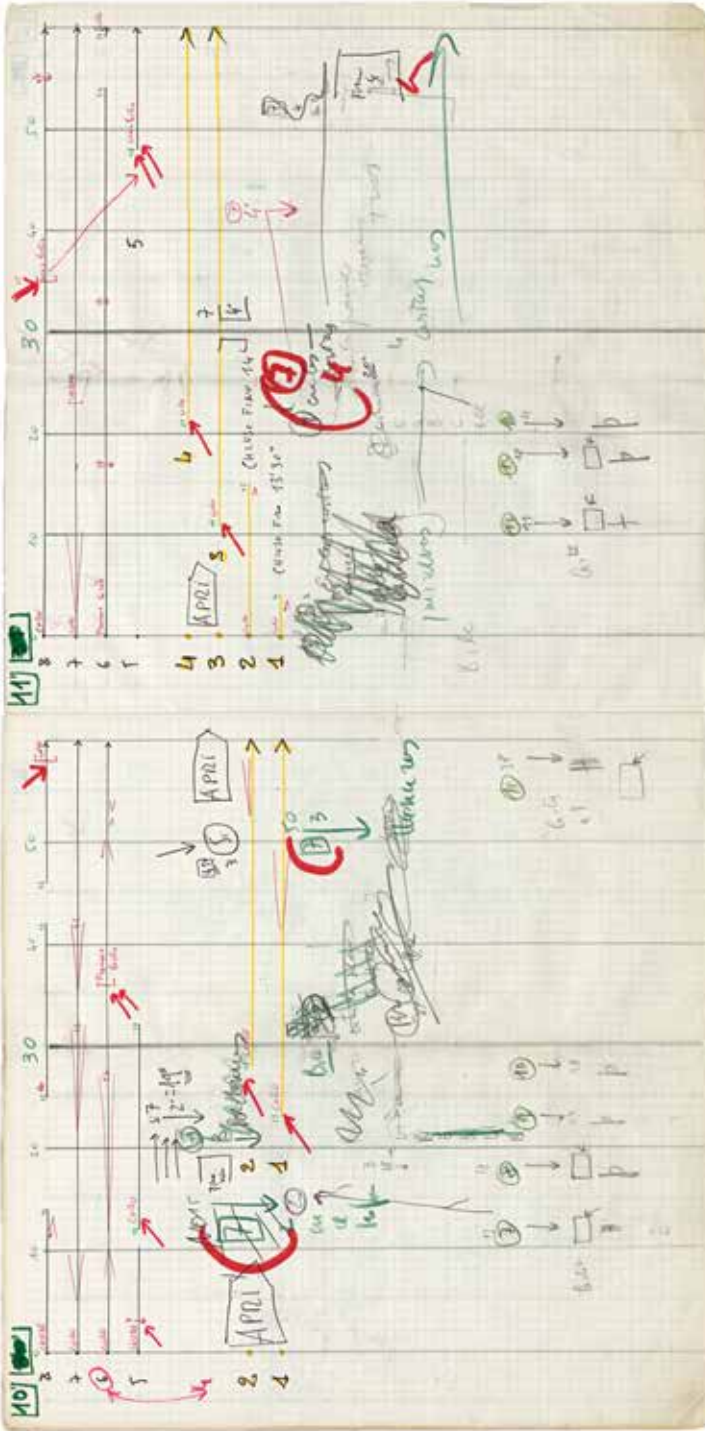

Figure 6: Excerpt from the tape score of *A floresta é jovem e cheia de vida* (Arquivo Luigi Nono (signature 30.11.17), reproduced with kind permission. © Heirs of Luigi Nono).

Several performances have followed, proving that a score constructed in this way is adequately instrumental in reviving the piece, albeit within the inherent and inevitable inconsistency of a prescriptive notation imposed on a work whose genesis prescinded from any written instruction. *A floresta* is indeed a case where it is hard to separate the collaborative composition of the music from its unique performance practice.

During his extremely fruitful residency at the Studio di Fonologia (1960–78), Luigi Nono's method of composing developed in a consistent evolution. With *A floresta* he had established a relationship with a core group of performers who soon became familiar with his sound world, and totally reliable in understanding his intentions. They were featured, along with others, in the three compositions which followed, *Contrappunto dialettico alla mente* (1968), *Un volto, e del mare* (1969),¹⁷ *Y entonces comprendió* (1970). In those pieces, any form of notation disappears, and it becomes very arduous to think of a possible reconstruction of them in terms of a conventional score.¹⁸ In *Un volto, e del mare*, for instance, two female voices provide the material for the tape and they also perform live, improvising over the tape. While listening to the piece, it is apparent that they were instructed to imitate and respond to their recorded and processed «doubles», but no clear instruction from the composer has ever been passed on. Nowadays, the only way of reproducing a legitimate rendition would be based on a careful study of period performances. Actually, performance practice workshops have been held with the original performers in order to establish an «oral tradition» that could ensure the survival of the musical work. This is not limited to the voices, but also involves the essential role of the sound projectionist, whereas the spatial disposition and movement of the tape part in accordance to the individual features of the performance ambience, is notoriously an essential aspect of Nono's music.

Mention should be made of an entirely alternative take on the «authenticity» of the performance practice of such pieces, making use of what has been dubbed as an «acousmatic rendition». Nono himself had envisioned a simulated performance of *La fabbrica illuminata* and had prepared a four-track version of the piece including the solo voice of Carla Henius mixed into the front (1 and 2) channels. This version was realised in order to make possible an optimal spatial rendition of the piece in situations where the local producer couldn't afford a real live singer. This choice had a clear political significance, since Nono was

17 *Un volto, e del mare* is actually the first part of the diptych *Musica Manifesto n. 1*, which also includes *Non Consumiamo Marx*, for solo four-track tape, with no live performers involved. Both pieces are basically self-standing, but the composer has always insisted that they belong together, and should always be performed as such.

18 *Contrappunto dialettico alla mente* has been released as a stereo phonographic piece, and has never been intended as a concert work with live performers, yet its conception and composition is very much similar to *A floresta*.

already trying to promote his music within a militant circuit, far from the ordinary music system. But, these motivations aside, this precedent gave birth to the idea of extending such a practice to other, more complex pieces, where the acousmatic version could offer the audience an experience far exceeding that of merely listening to a recorded performance.

In the case of *A floresta é jovem e cheja de vida*, the two existing production tapes containing the parts of the soloists and the parts of the percussion ensemble, respectively, can be played back on two front speakers, simulating the presence of the live performers, while the concert tape is being played back within the prescribed spatial arrangement of eight speakers. A configuration of the piece is therefore restored as an effective simulation of the original, «authentic» placement of all the sound sources. These, of course, can benefit from the crucial operations effected by the sound projectionist, whose musical task it is to dynamically balance the ten channels, thus realising the actual «live» rendition of the piece.

In this respect, the case of *Un volto, e del mare* is even more challenging, and differently so: of the surviving tapes pertaining to the genesis of the piece, one has been identified as containing materials that are just a variant of the live part – which is not notated at all and is indeed essentially improvised – as it is fixed on the record, sung and recited by the original performers.¹⁹ In this case the «solo» tape can be played back along the concert tape, over the four speakers required for concert performance, but in a fashion that can simulate the «wandering» of the live performers who, according to Nono's indication, have to start the piece sitting amidst the audience, then stand up and move around the space. Here, the role of the sound engineer is again that of a true performer, substituting, through improvised pan potting, the actual movement of the live voices with an invisible displacement of sound.²⁰

19 The tape has been identified by Francesco Tagliaferri in the course of his research on *Musica-Manifesto n.1*, see Id. «Io non scrivo per l'eternità», *Philomusica on-line* 15/2 (2016), especially pp. 148 (<http://riviste.paviauniversitypress.it/index.php/phi/article/view/1839>, accessed on 7 December 2017). The commercial recording, supervised by the composer, appeared on the LP *Non consumiamo Marx – Musica Manifesto n. 1*, I dischi del sole DS/182/CL (1969).

20 Such «acousmatic renditions» have been realised for several compositions by Nono on various occasions, following the experimental reconstruction of a 10-channel version of *A floresta...* realised by the author of this text. This was presented for the first time at the International Festival of Contemporary Music of the Venice Biennale, on 25 September 2011. On that and all subsequent occasions the pieces have been performed by Alvis Vidolin at the mixing table along with visuals including period footage and archival documents also curated by the author.

These examples, which have to be considered as experimental surrogates of live performances – and whose editorial status is still undecided – may be an interesting shortcut to solve some problems inherent in such pieces where notation has been reduced to a critical point, where a truly performable score had to be either constructed from scratch or could simply be reduced to some necessarily ambiguous verbal suggestions.

PASCAL DECROUPET*

A question of «versions»!? Three case studies about «performing» tape compositions of the 1950s (taken from the European repertoire)

1. Introduction

In the pioneering years after World War II, composers assumed that their craft and art would evolve towards a situation similar to that of painting: complete fixing of the composer's musical intentions without any disturbing mediation such as «interpretation» by performers. But the reality was quite different, because even the most rigorous studio productions were subject to the limitations of the technical state of the art. As a result, interpretative choices by composers and their technical collaborators were an inevitable fact even in recorded music. On another level, the strict transposition of theoretical acoustic knowledge proved to be of limited interest as soon as the problem was considered from a musical perspective. Practical compositional work in the domain of electroacoustic music therefore quickly led to a new kind of fundamental research concerning the proper sonic phenomenon and its specific musical use. Karlheinz Stockhausen's first electronic study was composed from a serial perspective using elementary determinations of all the sonic aspects in a quasi-atomistic approach. This was quickly considered insufficient for two reasons: firstly, the resulting «new sounds» did not achieve the expected sonic richness so that in all 1954 realisations after *Studie I* other means were chosen to transgress the limitations imposed by the simple addition of sinewaves (as can be seen in the compositions of Paul Gredinger and Henri Pousseur, as well as in Stockhausen's *Studie II*); secondly, the initial restriction to the nearly stable sustain phase with its proportions between the partials excluded such determinant elements as the attack and decay phase (which became the proper purpose of the compositional project in *Gesang der Jünglinge*). On this basis, the whole serial thought in music evolved towards more global and qualitative characterisations of sound complexes as well as identifiable strategies of formal association of sonic entities through an extended scale of transformation principles (as they are explicitly put in the foreground in Gottfried Michael Koenig's *Essay* and *Terminus* or Mauricio Kagel's *Transición I*).

*Université Nice Sophia Antipolis / Université Côte d'Azur Laboratoire CTCL (EA6307)

This reconsideration was almost generally adopted by 1955, with immediate positive consequences for the newly founded Studio di Fonologia Musicale in Milan.

Up to this point in history, electroacoustic music was recorded music,¹ even in projects incorporating instrumental and electronic sounds, as in Bruno Maderna's first composition titled *Musica su due dimensioni* (1952), elaborated with the help of Werner Meyer-Eppler at Bonn University.² John Cage's *Imaginary Landscapes* and *Credo in US*, using turntables, are certainly significant exceptions, but because of the production conditions of that time, Cage specified *Imaginary Landscape No. 1* to be produced in a broadcast studio and the resulting recording to be played in concert or on the air;³ however, thanks to the portability of hifi record players, such pieces have, since the 1960s, nonetheless been performed live with musicians at the turntables. Thus, even in the case of recorded music, questions remain regarding how these works should be performed today. In the French tradition (which in the 1970s led to the «acousmonium», i.e. an orchestra of loudspeakers of different sonic characteristics), the idea of «spatialisation» of a mono (later stereo) recording over a variable number of loudspeakers conforms to a concert practice adopted by Schaeffer's group as early as 1952. Stockhausen tried to consider the problem from another point of view by fixing the spatial sound dramaturgy on multitrack tapes, thus elevating the sound localisation to a supplementary compositional parameter. Nevertheless, his seminal work *Gesang der Jünglinge* does not exist nowadays in a technical format that allows it to be performed according to the composer's intentions of 1955–6. Therefore, the question today is: should an interpretative act based on the available source material aim to correct the composition's imperfect spatial image transmitted through its official four-track version? Pousseur's *Scambi* consists of 32 separated sequences, which the composer realised in the Studio di Fonologia Musicale in Milan during the Spring of 1957. These sequences are the basic material with which to realise a version according to a restricted number of rules. As such, *Scambi* is the first European «mobile» within the electroacoustic genre and was chosen by Umberto Eco as one of the referential examples to his reflections on *opera aperta*

1 The term «recorded music» is used here for all music fixed on any technical device. In French, the generalisation «musique sur support» exists, which is not limited to any technical mean.

2 Elena Ungeheuer, *Wie die elektronische Musik «erfunden» wurde... Quellenstudie zu Werner Meyer-Epplers Entwurf zwischen 1949 und 1953*, Mainz, Schott, 1992, pp. 133–135; Pascal Decroupet, «Elektronische Musik», in: Gianmario Borio and Hermann Danuser (eds), *Im Zenit der Moderne. Die Internationalen Ferienkurse für Neue Musik Darmstadt 1946–1966*, Freiburg i.Br., Rombach Verlag, 1997, vol. II, p. 86–87.

3 Susan Key, «John Cage's *Imaginary Landscape No. 1*: Through the Looking Glass», in: David W. Patterson (ed), *John Cage. Music, Philosophy, and Intention, 1933–1950*, New York and London, Routledge, 2002, p. 105.

and *opera in movimento* at the end of the 1950s and the beginning of the 1960s. Beside Pousseur's own realisations at the time, one version by Berio is nowadays especially known, a version that does not respect the connection rules indicated by Pousseur: contextual research on the aesthetic foundation of Pousseur's musical thought in the second half of the 1950s will provide material to understand Pousseur's reasons for reducing connection possibilities between the sequences. This is also of help in evaluating recent creative research conducted on *Scambi*, especially the «Scambi Project» led by John Dack, and in reconsidering from today's perspective a way to discuss works in «aleatoric» or «open form» (keeping in mind that composers like Stockhausen and Boulez progressively fixed formerly partially indetermined scores like *Klavierstück XI*, *Refrain* or *Don*, for instance). *Rimes pour différentes sources sonores* is a different case because, in 2005–6, Pousseur elaborated a «regenerated» version of his tape, fixing a spatialisation of the former mono tape (realised in 1958–9 in Brussels) on eight tracks (at the studio Tempo Reale in Florence) to obtain a «definitive» version requiring no additional manipulation during a performance (except balancing the sound with the different instrumental groups).

2. Stockhausen's *Gesang der Jünglinge*: tracking the composer's spatial imagination

For decades, Stockhausen's list of works has specified *Gesang der Jünglinge* as a four-channel tape composition. But in his 1958 article «Musik im Raum» (this text using in its first half earlier introductory notes to *Gesang* as well as to *Gruppen*), the composer refers to five loudspeaker groups.⁴ There also exist interesting documents concerning the history of its concert performances in the late 1950s, which have not been specifically addressed so far (even within my former

4 In some contributions, *Gesang* is said to have been initially conceived for six loudspeakers. This is an echo from the composer's article «Aktuelles» published in 1955 in volume 1 of *die Reihe*, an article completed during the stage of preliminary tests that would lead to *Gesang*. In this article, Stockhausen develops serial considerations based on rows of six elements, and the last paragraphs concern a «sextuple stereophony» with loudspeakers «placed around and above the listeners» (*Texte 2*, p. 56, *die Reihe 1* (1958), p. 51 [English edition]). When beginning the proper sketching of *Gesang*, the basic series counts seven figures, in accordance with the number of parameters. «Aktuelles» is thus no more than general contextual information about an evolving project and cannot be taken to advocate any analytical view of the composition *Gesang der Jünglinge*.

analysis of *Gesang*⁵) and which led to urgent questions about how to perform *Gesang* now that its composer has passed away.⁶

Before considering the specific problems of the concert performance of *Gesang der Jünglinge* a short digression concerning the commercially available recordings of the piece seems necessary, especially because solutions adopted in this context also had an impact on the concert performance practice. For *Gesang*, Stockhausen first published a mono mix in 1957 (the other pieces on this record being *Studie I* and *Studie II*);⁷ in 1962 a first stereo recording on LP, which also contained the tape of *Kontakte*.⁸ When recording a new version of *Kontakte* with instruments in 1968 with Aloys Kontarsky at the piano instead of David Tudor, who had played in the first recording, realised in parallel to the premiere in June 1960 in Cologne and issued on record since 1963, and Christoph Caskel playing the percussions in both recordings,⁹ Stockhausen mentions extensive experiments with the loudspeaker positions, having adopted a recording procedure where the tape was added during the final mixing, but not recorded through microphones at the same time as the instruments. This recording thus has an autonomous status as an artistic realisation and is not a «documentation» of a concert situation as required in the score. The resulting stereo image was subdivided into four panoramic fields, one per track on the tape: I at the extreme left, II 1/3 left, III 1/3 right, IV at the extreme right. This distribution is in a certain sense «wider» than that in a concert performance because the front-to-rear axis is integrated into a kind of frontal stereo image. Upon comparison with the score (*Aufführungspartitur*) published in 1966 and the detailed introduction by Helmut Kirchmeyer to the first record on Wergo¹⁰ (including a sketch concerning the spatial repartition of the musicians and the loudspeakers [Fig. 23, col. 34], as well as a photograph of a performance in Stockholm in November 1960 [Fig. 9, cols 15–16], also contained

5 See Pascal Decroupet and Elena Ungeheuer, «Through the Sensory Looking-Glass: The Aesthetic and Serial Foundations of *Gesang der Jünglinge*», *Perspectives of New Music* 36/1 (1998), pp. 87–142; also in: *Electroacoustic Music. Analytical Perspectives*, ed. Thomas Licata, Westport and London, Greenwood, 2002, pp. 1–39.

6 The present article does not discuss the numerous concert performances of this piece in the 1950s when the required number of loudspeakers (or loudspeaker groups) was not available.

7 Information concerning Stockhausen's records is contradictory. In addition to little mistakes concerning numbers, the dating is another problem. Reference information for this contribution has been taken from Discogs.org. The monaural version of *Gesang* was published on DG LP 16133 (1957–1961) and DG LPE 17243 (1964). A review appeared in *Melos* 25/6 (1958), pp. 211–212.

8 DG SLPM 138811 (1962–1969).

9 VOX STGBY 638; this recording is also contained on Stockhausen CD 6.

10 Helmut Kirchmeyer, «Zur Entstehungs- und Problemgeschichte der *Kontakte* von Karlheinz Stockhausen», introductory text to WERGO 60009 (1963).

in the *Aufführungspartitur*, p. II of the introduction¹¹), it becomes obvious that Stockhausen, when he had to adapt to different concert halls, at the time used at least two loudspeaker setups: the one he later fixed as obligatory situation, i.e. the speakers in the corners, the numbering beginning in the rear left and then rotating clockwise; the other, called «Himmelsrichtungen», that is to say in the centre of the respective walls of the concert space, loudspeaker 1 being on the left, the numbering rotating clockwise.¹² Musically, the latter makes much more sense because tracks 1 and 3 contain prominently instrument-like sounds, so that their placing in immediate proximity to the instruments (as shown in the sketch reproduced by Kirchmeyer) enhances the «contacts» between the two sonic universes drastically. The spatialisation adopted for *Gesang* was similar. The basis for both stereo records, the first (1962) and the second (1968), with two different stereo mixings (according to Stockhausen), was the «four-track tape» realised after the first performance by combining in track 4 the former tracks 4 and 5.¹³ Indeed, by that time (by 1962), the isolated track 5 was no longer available. The spatial repartition heard over headphones is identical to that of *Kontakte*, so that track 1 sounds clearly on the extreme left. The proximity between both stereo records and a concert performance is thus greatest when loudspeaker I is heard distinctly at the left. This could explain Stockhausen's choice to place track 1 in the rear left corner for *Gesang* too when performed in concert using the four-track tape. But shouldn't a concert performance adopt proper criteria, even if this might be disturbing for listeners who are used to the record, having almost memorised the spatial strategies fixed on the stereo record?

As will become obvious, the history of space in *Gesang* is a history of compromises. Nowadays it is possible to transcend certain limitations that Stockhausen had to accept, and therefore, why shouldn't we imagine a concert practice that best reflects the intention the composer had during the composition of his piece, even if he never did hear the composition in this exact way in his lifetime?

11 Another photograph of this same performance in Stockholm is found in Karlheinz Stockhausen, *Kompositorische Grundlagen Neuer Musik. Sechs Seminare für die Darmstädter Ferienkurse 1970*, ed. Imke Misch, Kürten, Stockhausen Verlag, 2009, p. 240. It shows Stockhausen in a central position, almost between the two performers; part of one of the loudspeakers appears at the right edge of the photograph, to the right of David Tudor.

12 The term «Himmelsrichtungen» appears in the introductory text to the VOX recording (reproduced in *Texte 3*, Cologne, DuMont, 1971, p. 28), where Stockhausen indicates two alternative loudspeaker positions: in the corners («Saalecken») and the four cardinal directions (a technical scheme on p. 30 shows loudspeaker I in the left rear corner – this scheme is also valid for *Telemusik*). The *Aufführungspartitur* in the version edited by Universal Edition in 1966 (UE 14246 LW) allows only one possibility for the loudspeakers when the piece is performed with instruments: «at left, front, right and behind» (p. I of the introduction – all other descriptions of loudspeaker positions concern the stereo tape), thus the «Himmelsrichtungen».

13 Karlheinz Stockhausen, *Elektronische Musik*, CD 3, Kürten, Stockhausen-Verlag, 1992.

The first consideration: the number of tracks

1. At the beginning of the production, which also entailed the spatialisation of first parts of the piece, Stockhausen used an Albrecht four-track film machine. As soon as the Telefunken four-track 1 inch recorder was available at the studio (in *Tonträger 11*, which had recently been devoted to the production of electronic music), transfers were made onto this device, which was then also used for the first concert performance on 30 May 1956, synchronised with a mono tape (track 5) on another tape machine playing back the fifth channel.¹⁴
2. The synchronisation of these two machines was not sufficiently stable for the performance lasting about 13 minutes, so Stockhausen decided to synchronise tracks 4 and 5 onto a single track (resulting in track 4 of the official four-track tape available from the Stockhausen-Verlag).¹⁵
3. As mixing plans dating from the end of the 1950s (transcriptions at point 11 of this article, below) contained in the sketch folders of *Gesang* show (section V of the photocopy edition realised in the 1980s but not contained in the facsimile edition published in 2001),¹⁶ Stockhausen performed the piece on five loudspeakers, because on the mixing console the four input tracks were routed to five output tracks (see Example 1 below). It is not unreasonable to believe that the composer proceeded in this way for a certain number of years. I consider this performance practice the most reliable reference in order to reflect on a «historically and aesthetically informed» performance practice for today.

14 The concert review by Heinz-Klaus Metzger in *Melos* (23/7–8, 1956, pp. 220–223) is complemented with two photographs, the second (on p. 222) showing Heinz Schütz, one of the technicians of the WDR closely associated with the production of the electronic studio, operating the Albrecht four-track machine (the caption calls it «Tonwerfer»). The information concerning the Telefunken four-track recorder was provided by Kees Tazelaar on the basis of testimonies from Gottfried Michael Koenig, both his correspondence of those years and Koenig recalling having never used another device than this 1 inch four-track recorder to realise his own *Klangfiguren II*, premiered in the same concert as *Gesang* and composed in the first months of the year 1956. See also Patrick Valiquet, «The spatialisation of stereophony: taking positions in post-war electroacoustic music», *Proceedings of the International Computer Music Conference 2011*, University of Huddersfield, 2011, p. 45 (information also provided by Koenig).

15 Stockhausen, *Elektronische Musik*, CD 3, cit., p. 42.

16 The photocopy edition has been studied at the Paul Sacher Foundation in Basel; the title of section V is «Notizen aus der Zeit der Entstehung von *Gesang der Jünglinge*»; for the facsimile: Karlheinz Stockhausen, *Gesang der Jünglinge. Faksimile-Edition 2001*, Kürten, Stockhausen-Verlag, 2001.

4. When during the 1980s, Stockhausen often performed *Gesang* to complete concert programmes with excerpts from *Licht*, for example together with *Michaels Reise*, he used the four-track tape as it was, connected to four loudspeaker groups. In the late 1980s and early 1990s, when I undertook my sketch studies on the composition in the context of my doctoral dissertation, I heard such performances myself a certain number of times with Stockhausen at the mixing desk. I remember very clearly having always been heavily disappointed because of the obvious «limping» of specific spatial rotations (namely in part C of the composition) that should sound as smooth as possible, but which actually always stopped the regular or progressively slowing down movement at the rear right loudspeaker. What was the origin of this situation that appeared to me to be obviously a «musical mistake» that needed to be elucidated and if possible corrected?
5. Towards the end of the 1990s, some of my activities were linked with a studio of electronic music (Centre de Recherches et de Formations Musicales de Wallonie, nowadays Centre Henri Pousseur, in Liège, Belgium). I was then allowed to buy a digital four-track copy for concert performances from the Stockhausen-Verlag. This served as the basis for my first reconstruction of a five-track version, which is nothing other than a prefixed output according to Stockhausen's performance practice of the late 1950s: what Stockhausen had to achieve in real time during the performance was now realised in the studio on a multitrack program on computer by simply playing with the volumes to «re-separate» the original tracks 4 and 5. There are a few passages where the superimposition of tracks 4 and 5 could not be inverted into two channels with distinct sonic information, so this version is, of course, not a reconstitution of the original five-track version, but only an approximation, which to me still remains convincing. Indeed, as I excluded intervening on the sounds themselves with filtering devices, the only solution was to rely on the temporal onsets and sound ends for each channel to simulate the spatial dramaturgy, even if what is heard in both loudspeakers during the channels' superimposition is, strictly speaking, the same combination of sounds (which was not the case in the original situation). When I presented this version to him in the early 2000s, Stockhausen showed a certain interest in it, but he never went so far as to authorise it in addition to the four-track tape sold with his editions. However, he never explicitly forbade its performance.

The second consideration: the placement of the loudspeakers

6. In Stockhausen's writings of the 1950 (concert programs, broadcast presentations or the article «Musik im Raum»), there is an always identical indication according to which the five loudspeakers are to be placed around the public.¹⁷
7. With the exception of the above mentioned still very general intention exposed in «Aktuelles», the idea of a loudspeaker sounding from above the listeners appears only at a later stage of conversations and writings. Considering the schemata in the last section of the article «Musik im Raum»,¹⁸ one could imagine that the cross in the centre of the triangle could simulate such a situation. But, as should be widely known, these schemata relate to a first spatial conception for *Kontakte* with three percussionists at the corners of the triangle and the pianist in the centre (i.e. the cross). This ambiguity was created by Stockhausen himself, and over time, he went further and further in the construction of a veritable myth concerning the central loudspeaker. In his interview with Mia Tannenbaum (given while he was composing the first parts of *Licht*), we read about «a fifth track with a boy's voice sounding from above in the first bars [...] No technician has never wanted or known how to arrange a loudspeaker on a ceiling».¹⁹ Robin Maconie, with reference to this interview, fixes the idea of the central loudspeaker,²⁰ and this pure myth has since then become the norm, uncritically adopted by so many other writers. In the last years of his life, Stockhausen edited many of his texts in audio versions: certain recordings date from the 1950s and 1960s and consist of the original broadcast tapes of his texts (sometimes with slight modifications in accordance to the later print version), but others were specifically recorded for this edition. This is the case for «Musik im Raum», a text that had been given as a lecture in Darmstadt (Ferienkurse, summer 1958), Brussels (Expo, autumn 1958) and on his tour through the United States in late 1958, but had not been recorded for broadcasting at the time. In the CD version, Stockhausen adds a certain number of passages to the written version known up to then. Concerning *Gesang*, the newly added paragraph (track 1 from 1'39" to 3'34") specifies the central position of the fifth loudspeaker

17 Karlheinz Stockhausen, «Musik im Raum», *Texte 1*, p. 153; English version in *die Reihe 5* (1961), p. 6.

18 Stockhausen, «Musik im Raum», p. 170; *die Reihe 5* [English edition], p. 79.

19 Mia Tannenbaum, *Conversations with Stockhausen*, Oxford, Clarendon Press, 1987, p. 24.

20 Strangely enough, he confuses this information with that concerning the originally planned six loudspeakers (see «Aktuelles»), speaking of a «reduc[tion] to the five in a horizontal array» for the definitive version. Robin Maconie, *The Works of Karlheinz Stockhausen*, Oxford, Clarendon Press, 2nd ed., 1990, p. 60.

and its placement on stage for the first performance, as it had been forbidden to hang it from the ceiling for safety reasons.²¹

8. While again studying the published sketch material of *Gesang*, different details suggested that I consider the problem once again. The basis for the proposal presented here is the fact that Stockhausen himself for decades had accepted the presentation of this piece in a truncated spatial version. But instead of considering this fact as validating the four-track version today as the only (since remaining) intention of the composer, I am now inclined to consider that even the five-track version was nothing but a compromise. Indeed, what the second realisation score of the piece shows is that part A of the score is conceived for four loudspeakers, speaker 1 being specified as «hoch» (i.e. to be placed higher than the others), while for the remainder of the composition, parts B to F (since part G has never been completed), the score is drawn for five loudspeakers, without any further specification relative to their vertical placement. Musical coherence at several places of the composition allows only one possible arrangement consisting of five equidistant loudspeakers in a single plane surrounding the audience.
9. Commenting on my five-track version, Stockhausen had suggested correcting the volume of part A by increasing it by some 6 dB for the first minute, as he considered it to be wrongly «normalised» on his own four-track tape with regard to the rest of the composition. This improvement should be added to my version either during performance or in a new studio mixing session to fix it the way he himself performed his four-track tape. What this indication shows beyond the simple improvement of global balance is the fact that the conception and multitrack realisation of part A remains in a certain way separate from the rest of the piece.
10. At the bottom of the first page of the second realisation score, there is a little graphic sketch concerning the spatial distribution of the loudspeakers. In this sketch, speaker 1 seems to have been considered as an exception with regard to the others because to figure 1 (representing speaker 1) is added the indication «h.» (for «hoch», as in the track specification of the score), the other figures appearing without any further specification. The repartition of the figures in the square representing the concert space suggests that the basic positioning concerned only four loudspeakers, as in the score for part A; figure 5 was added at a later stage, thus leading to an irregular repartition. The initial four loudspeaker positions do not confirm the later standard of

21 «Die fünfte Spur, auf einem separaten Tonband, sollte mit einem Lautsprecher von der Mitte der Decke herunter klingen. Aber schon bei der Uraufführung wurde aus Sicherheitsgründen verboten, einen Lautsprecher an der Decke zu befestigen. Deshalb stellte ich einen fünften Lautsprecher vorne in die Mitte des Podiums.» (tape transcription of CD version of «Musik im Raum», specific addition.) A similar formulation is found in *Elektronische Musik*, CD 3, cit., p. 42 («Ergänzung 1991»).

loudspeakers placed in the corners of the space, but a rotation by 45° , that is to say the placement of the loudspeakers at the centre of each side of the square (or rectangle).

11. The mixing plans found in section V of the sketch folders do not only concern *Gesang*, but also other pieces produced in Cologne, Milan and Brussels at the end of the 1950s. These compositions exist either as four-track or as stereo tapes. The mixing plan for the four-track tapes of Franco Evangelisti's *Incontri di fasce sonore*, Koenigs *Essay* and György Ligeti's *Artikulation*, in particular, confirm the idea of the 45° rotation principle because speakers 1 and 2 are considered to play the same signal (track 1). A further consequence of this fact is that these two loudspeakers need to be placed in a frontal position with regard to the audience, this specific signal thus being simply «larger» than the others (which is not unusual with respect to listening to a group of musicians on the stage).²²

Figure 1: Transcription of mixing plans contained in Stockhausen's sketch folders.

[I]

Evangelisti, Koenig, Ligeti

x			
x			
	x		
		x	
			x

supplementary indications: Announcement W 66 / 1+2, position 15. No red light as long as white has not disappeared!

22 The other source material consists of three drawings of concert halls with the specific loudspeaker placement to be adopted (pp. 23, 31 and 32 of the facsimile edition). Pages 31 and 32 must be turned upside down, according to the handwritten indications at the top of p. 31 (which should be its bottom). The rotation is evident in all three sketches, but while on p. 23, speakers 1 and 2 do not appear in one completely frontal plane, they do in the two others. I do not have any explanation for the reasons why on p. 32 speakers 4 and 5 (not specified as such, this is my reading) appear closer to one another than in the two other sketches (which suggest an equidistant distribution).

[II]

Maderna, Pousseur, Berio

x			
x			
		x	
	x		
			x

manuscript indications: Rimes as for Ligeti, Omaggio as for «Jünglinge»

[III]

Stockhausen

x			
	x		
		x	
			x
			x

12. Photographs of the 1956 concert with the first performance of *Gesang* either show the placement of one group of loudspeakers at the left corner of the stage²³ (when seen from the audience) or even the complete scene with one group of loudspeakers at each end, thus confirming the information given above concerning two groups of loudspeakers in a frontal position.²⁴ On this basis, all indications of a central loudspeaker (hanging from the ceiling or placed on stage) have to be considered as erroneous recollections of the composer himself.

23 Stockhausen, *Texte 1*, photograph facing p. 152; also in *Elektronische Musik*, CD 3, cit., p. 40.

24 *Melos 23/7–8* (1956), p. 221.

The musical consequence of all these considerations would be the playback of track 1 over two distinct speakers used successively, one (for part A) to be placed higher than the other five (the other being used for track 1 for parts B to F), and thus to play *Gesang* on six loudspeakers. Furthermore, a general rotation of the basic four-track square has to be applied so that the following disposition would result: 1 – front left (instead of the usual rear left), 2 – front right, 3 – 2/3 to 3/4 rear right, 4 – rear centre, 5 – 2/3 to 3/4 rear left, 6 – front left above 1 (possibly a little bit more centred, but not completely in the middle of 1 and 2).²⁵ This positioning would respect Stockhausen's idea of the first loudspeaker of part A sounding in the front plane of the audience while the others «answer» from the audience. Such a spatial disposition clearly evokes the traditional church relation between the priest and the congregation. To be completely convincing, this requires the transfer of tracks 2-3-4 of the official four-track version to tracks 3-4-5 in the revisited version. At the end of part A, track 1 having sounded up to this point in the higher speaker 6, continuity is nevertheless guaranteed with a return to the tracking of the (now rotated) five-channel version, since part B begins in speaker 1 with choirs of the same nature as those that sounded from the audience in part A – thus, the change from the higher to the normal speaker in approximatively the same panoramic position will sound completely natural and musically convincing.

3. Pousseur's *Scambi*: an open but nevertheless «post-Weberian» organic form – compositional criteria and constraints for realising specific versions

Pousseur's first electronic composition, *Seismogramme*, was composed in 1954 in the studio of the Nordwestdeutscher Rundfunk at Cologne, at a time when the prior compositional preoccupation was the information of each sound «from inside» through specific proportions among the «musical atoms», i.e. (at that time) the sinewaves constituting the partials of a hopefully new timbre. Soon after the Cologne concert of 19 October 1954, Pousseur began to draft a new electronic composition (which was never realised), still based on the idea of additive synthesis by sinewave superimpositions. During the spring of 1955, while finishing his *Symphonies à quinze solistes*, Pousseur also undertook a number of analyses of

25 To obtain the best result, the two front loudspeakers should not be positioned at the respective edges of the scene, but in such a way that the basic pentagon is as regular as possible and so that loudspeakers 3 and 5 sound distinctly «more towards the right or the left» than loudspeakers 2 and 1, respectively.

works by Webern, resulting in his famous contribution to number 2 of *die Reihe*: «Anton Weberns organische Chromatik»²⁶. It is important to keep this in mind in the present context because this introspection into Webern's harmonic universe and the consequences Pousseur deduced from there also had considerable consequences for his next electronic project. During the summer and early autumn of 1956, Pousseur completed his next essay to be published in *die Reihe*, «Zur Methodik»: ²⁷ the version that became publicly known resulted from big shortenings both affecting the introduction and the end of the typescript.²⁸ Indeed, the idea Stockhausen had pointed out to Pousseur earlier in their correspondence²⁹ was to publish a volume with contributions about compositional problems that had been practically experienced, and not visions about possibilities and eventualities. Fourteen pages of conclusions were devoted to the description of a number of projects that were not even under way yet. While for the third volume of *die Reihe*, such expectations were finally judged inappropriate and the end was thus reduced to only two pages concerning the instrumental pieces Pousseur planned to compose as prolongation of his *Exercices pour piano*, which was described in all details in the core of the article, the then unpublished end is of central importance in the present context in order to understand Pousseur's position for *Scambi* and for *Rimes pour différentes sources sonores*.

One aspect of *Scambi* that seemed strange within serial composition in the middle of the 1950s was its almost exclusive concentration on noise as basic compositional material (in this respect, it went even further than Koenig's *Klangfiguren II*, in which white noise was used as a specific electronic timbre besides sinewaves and impulse complexes to realise the time/pitch figures).³⁰ But why abandon sound composition through the addition of sinewaves to shift towards such an uncontrollable material as noise? This is precisely the point of Pousseur's demonstration in the original conclusion to «Zur Methodik». Important parts of

26 Henri Pousseur, «Anton Weberns organische Chromatik», *die Reihe* 2 (1955), pp. 56–65; English version 1958, pp. 51–60; French original in Henri Pousseur, *Écrits théoriques 1954–1967*, Sprimont, Mardaga, 2004, pp. 15–28.

27 Henri Pousseur, «Zur Methodik», *die Reihe* 3 (1957), pp. 46–88; English version 1959, pp. 44–88; French original in *Écrits théoriques 1954–1967*, cit., p. 197–259.

28 The available sources do not correspond to a coherent typescript realised in 1956, because the central part of the text, containing the technical explanations, consists of a new dactylography realised towards the beginning of the 1970s with the perspective of a then unrealised publication of a second volume of *Fragments théoriques* (the title Pousseur had used for his first volume of writings published in 1970). In the typescript of 1956, the original introduction counted 18 pages of principal text (numbered 1–18), the conclusion 14 (numbered 32–45).

29 Letter from Stockhausen to Pousseur, [early] October 1955 – Stockhausen's first request for a new article by Pousseur is contained in an earlier letter, [ca. 22] September 1955 (Paul Sacher Foundation, Sammlung Henri Pousseur).

30 Gottfried Michael Koenig, «Zu Klangfiguren II (1955/56)», *Ästhetische Praxis. Texte zur Musik* 1, Saarbrücken, Pfau, 1991, p. 4.

this conclusion that relate to consequences to be drawn from Webern's model entered Pousseur's next text, originally published in 1957, in number 2 of *Incontri musicali*, «La nuova sensibilità musicale».³¹ According to Pousseur, Webern's poetic essence lies in a maximum of irregularity that opens up a new musical conception by counterbalancing musical tensions within every parameter so that no simplification of the surface complexity (in the sense of the «strong forms» so prominent in gestalt psychology – one important source of reflection for Pousseur at that time) was possible through priority given to one parameter, and especially not to pitch. In a certain sense, one principal aim of Pousseur's electronic project was the complete elimination of pitch as a possible reference for the listener. But as soon as this would be achieved, the formal distribution of the resulting multiparametric data would also need to integrate the domain of «multipolarity» (Pousseur's keyword to denote post-Webernian tensions – a systematic generalisation of Webern's *Alles schwebt* – in all musical aspects).

Here are a few longer quotes from the 1956 typescript:³²

C'est donc à un contrôle de la complexité vibratoire effective qu'il faudrait tendre plutôt qu'un contrôle pur et simple des nombres de partiels. On le voit aisément, le problème de la *non-périodicité* interne des phénomènes sonores est directement lié à celui de la *multipolarité* de leur articulation extérieure. Ce sont là deux plans, deux niveaux différents d'une question unique et ce seront des considérations semblables (celles sur le rôle du chromatisme, sur la rupture des régularités sensibles, etc.) qui permettront d'y trouver une réponse. L'expérience de l'articulation multipolaire des groupes de fréquences reconnaissables, de sons à hauteur ponctuelle, est donc la base même d'une recherche [appliquée] au domaine des phénomènes sonores *non périodiques*, domaine qui s'identifie pour nous, d'une manière absolue, à la mise en œuvre des moyens électroniques de réalisation musicale. (Typescript, p. 42)

[...]

Avec le dualisme *bruit-son* se trouve donc également suspendu, et cette fois d'une manière intégrale et inconditionnelle, le dualisme *matière-forme*. Il est possible (il est sans [doute] nécessaire, si tout ce qui a été dit jusqu'à présent est juste) de composer des œuvres où l'on ne puisse plus percevoir à aucun niveau des articulations rigides, des subdivisions strictement délimitées : celles-ci aussi instituent un schématisme fondamental, des « formes fortes » transposables indifférentes à l'actualité sonore immédiate. Les formes – si nous pouvons encore employer ce vocabulaire –, les articulations *macroscopiques* doivent au contraire renvoyer constamment l'auditeur attentif à leur propre intérieur, à leur matérialité la plus actuelle.

31 Henri Pousseur, «La nuova sensibilità musicale», *Incontri musicali* 2 (1957), pp. 3–37 (the text is dated at its end: January 1957); French original in *Écrits théoriques 1954–1967*, cit., pp. 61–94.

32 There are two places in the quoted excerpts where there are obviously incomplete sentences or where a blank was left open for inserting a missing word. Since I do not know about a typescript with further manual corrections, these imperfections could not be corrected for the present publication. They are indicated by [**x**]. Other imperfections seemed to be easily improvable, so I did the corresponding «editing» (signalled by the usual [brackets]).

Les processus évolutifs dirigés présentent, on le comprend aisément, un danger non moins évident pour la réalisation de cette dernière exigence. En eux se produit également une polarisation, une ponctualisation du présent. Simplement, le point, le pôle change de place, selon une direction parfaitement linéaire. Ici aussi l'auditeur risque d'être projeté hors de lui-même, sur la pente d'une prévisibilité, d'une fatalité, abstraite, transcendante à la matière temporelle. Mais, dirait-on, si les grandes subdivisions perceptibles doivent être exclues du discours aussi bien que les grands processus évolutifs, la durée des œuvres va tendre à s'uniformiser, à se niveler en une sorte d'entropie sans aucun intérêt. En gros, tous les moments présents se ressembleront et l'ennui le plus certain s'installera dans la conscience de l'auditeur. L'on aura atteint un objectif exactement contraire à celui qu'on s'était proposé : le renouvellement créateur de tous les instants, l'émerveillement ininterrompu de la sensibilité. Il ne peut évidemment en être question. Il faut que, considérée à *n'importe quelle échelle*, à n'importe quel niveau articulaire, en regard de n'importe quel module chronométrique, l'œuvre fasse toujours preuve d'un maximum de différenciation, il faut qu'à travers la transformation du présent, la conscience auditive puisse également saisir des intervalles caractériels plus étendus, distribués sur des périodes temporelles suffisamment amples pour que la durée totale de l'œuvre reste aussi vivante que chacun de ses moments. Ceci peut s'effectuer, nous semble-t-il, d'une manière qui ne soit ni celle des plans opposés, parfaitement délimités, ni celle des transformations directionnelles, absolument continues. Le type de transformation lui-même doit constamment se *["**missing part**"]* transformatoires elle [sic] aussi, et ainsi de suite. La non-périodicité doit être aussi profonde que possible. (Typescript, p. 43)

[...]

Une dernière subdivision analytique va devoir être jusqu'à un certain point dépassée : celle des paramètres. Dans une musique où la matière est soumise à une transformation aussi perpétuelle et aussi multiple, où la forme s'identifie entièrement aux modifications les plus fines de cette matière, bref à cette matière elle-même, l'auditeur ne pourra plus saisir séparément, même par une opération perceptive artificielle, par une audition arbitrairement analytique, l'évolution de la sonorité à *un seul* point de vue, dans une seule de ses dimensions. [...] S'il peut cependant être nécessaire, pour des raisons méthodiques, de conserver une certaine spécificité dimensionnelle, un pouvoir de contrôle et de détermination particularisé, l'« échelle » des paramètres ne pourra plus être considérée comme une série discontinue de dimensions autonomes. Elle devra être traitée elle-même comme une *["**blank**"]*, où les différents « aspects » ne représenteront que des pôles, que des centres d'efficacité, entre lesquels il sera possible et souvent nécessaire, pour conformer la description analytique à la vérité de la perception, de choisir un grand nombre de « points de vue » intermédiaires. (Typescript, p. 44)

The next source for *Scambi* stems from a letter Pousseur wrote to Berio once the composition was finished, Berio being obviously interested in knowing a little more about the principles that allowed Pousseur to realise his sequences, since he himself wanted to put together a version.³³ Pousseur sent Berio a description of the sequences of the material tape culminating in a «tableau synoptique» and a set of rules to combine the sequences in order to realise a version. Here are both excerpts from this undated letter (probably from the beginning of summer 1957):

33 Indeed, as far as I know, no original sketches for *Scambi* have survived.

La bande «matériel» comprend les 16 sections dans l'ordre suivant :

//FE/CD/EC/DF//DA/EG/AE/GD//BC/HF/CH/FB//GH/AB/HA/BG//

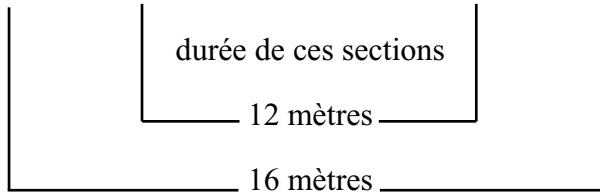

Chaque section est conservée dans 2 versions (rangées successivement) légèrement différentes l'une de l'autre : on peut choisir celle qu'on préfère. Mais comme tu sais, on peut également employer les sections rétrogradées, ce qui ajoute aux 16 sections

//GB/AH/BA/HG//BF/HC/FH/CB//DG/EA/GE/AD//FD/CE/DC/EF//

Les deux lettres, par lesquelles chaque section est désignée, signifient les «points caractériels» de départ et d'arrivée : chaque point caract. représente un état précis à chaque paramètre : un maximum ou un minimum. Les paramètres sont les suivants :

	minim.	max.
Débit (vitesse des signaux <u>secs</u>)	[quelques points]	[nuage de points]
Hauteur (registre moyen de la structure)	env. 200 p/s.	env. 5000 p/s.
Echo avant } Echo arrière }	signaux secs seuls	écho seul
Rapport des «silences généraux» et des structures	<u>beaucoup</u> de silences	<u>peu</u> de silences

Voici l'état de ces 5 paramètres pour les 8 points caractériels différents :

1 = minimum 5 = maximum

	A	B	C	D	E	F	G	H
Débit	1	1	5	5	5	5	1	1
Hauteur	5	1	1	5	5	1	5	1
Echo av.	1	5	1	5	1	5	5	1
Echo ar.	1	5	1	5	1	5	5	1
Silences	1	1	5	5	1	1	5	5

Les sections ne peuvent être enchaînées «organiquement» que par point caractériel commun par ex : DA AE EF etc.

D'autre part, comme tu sais, on peut en mettre deux au bout d'une :

AE

DA – mais : il est à conseiller de ne pas superposer rigoureusement deux sections

AB ayant un même point caractériel de départ (ou d'arrivée)
et une même longueur (donc, appartenant à un même groupe de 4),
par ex. DA
EA.

En effet, ces sections ont été obtenues, 4 par 4, par manipulation ultérieure d'une même structure de signaux secs.

Comme tu sais, enfin, la dynamique générale ne doit être réglée qu'après établissement du plan de synchronisation.

The indicated lengths of 12 and 16 metres correspond to durations of 30 and 42 seconds. This clearly indicates that while Stockhausen in *Gesang der Jünglinge* was explicitly concerned with transformations within a given sound and Koenig in *Klangfiguren II* with the ambiguity between «processual sound» and «sound processes» (depending on the kind of «destruction type» applied to the reference gestalt), Pousseur, in *Scambi*, devotes himself completely to processual transformations of sonic qualities. As described to Berio, each sequence begins with a given multiparametric situation and is transformed into another situation, certain parameters remaining constant, while others change into the opposite characteristic. The detailed working procedure was described in an article published soon after the piece was finished (in German and English in *Gravesaner Blätter*), stressing five parameters.³⁴

A few years later, when preparing the «Prologue sur le théâtre» for his operatic project *Votre Faust* in the middle of the 1960s, Pousseur undertook an analysis of the different sequences of *Scambi* to combine this material with excerpts from *Gesang der Jünglinge* and *Thema, Omaggio a Joyce*. Is that to say that only a few years after the realisation he could not find his sketches any more? Thus, analysing the sequences by listening, Pousseur himself reduced the number of parameters to four. Indeed, in the earlier sources, Pousseur distinguished «echo before» and «echo after» among these parameters, but in the final sequences, both these echoes merge into one perceptual quality (the musical coherence of this simplification is corroborated by the fact that, as indicated in Pousseur's letter to Berio, both types of echo appear in strict situational parallelism).

34 Henri Pousseur, «Scambi», *Gravesaner Blätter* 13 (1959), pp. 36–47 (German) and pp. 48–54 (English); Italian translation in *La musica elettronica. Testi scelti e commentati da Henri Pousseur*, Milan, Feltrinelli, 1972, pp. 135–147; French original in *Écrits théoriques 1954–1967*, cit., pp. 147–159.

But let us first reconsider the context and the conditions in which *Scambi* was realised. Because of the short scheduled time (a total of only six weeks) to realise his project in Milan, Pousseur decided to use precisely those means available at the Studio di Fonologia Musicale that allowed real-time transformations to generate his sound material, which thus featured transitions between given characteristics determined through serial operations. To avoid immediately perceptible, since directed, evolutions (which would attract the perception in such a manner that a hierarchy between the parameters would fix the attention on precisely one parameter), these transformations evolve by successive irregular waves exploring the total available range of variation in each parameter, so that a starting situation transforms into a goal situation without anticipating the latter in all its aspects (otherwise, an expectation would grow rather early in the process and would then simply be confirmed).

The following table recapitulates the production process according to the steps enumerated by Pousseur in his article:

Example 2: Tabular reconstruction of the realisation process according to Pousseur's description in *Gravesaner Blätter*.

<i>stages</i>	<i>steps</i>	<i>devices, settings and manipulations</i>	<i>intermediate results</i>
production of 4 basic models (pitch/speed)	1	11 filter positions (half octaves) combined with five speeds of selection (dynamic filter) each	55 results
	2	mixing of three neighbouring versions into nine frequency bands to enhance the inner mobility (for each of the five selection speeds)	45 results (with stable pitch sensation)
	3	irregular selection of passages (from 0.5" to 2" by tape selection) combined with variable speed resulting in a modification of the pitch sensation to enhance the outer flexibility	45 results (with changes in pitch sensation)
	4	splicing of the tape fragments by mixing neighbouring speeds to realise statistical changes within the global flow results in four models with specific evolutions in pitch/speed	4 models <i>families: 5-6/ 3-4/11-12/15-16 + reversed versions = 8 models</i>
transformation of the four models into 32 sequences	5	echo chamber (double step to produce also «echo before» the sound through reversing the tape) to produce eight models (four normal and four reversed) with transitions between dry and reverberated sounds (two different processes for each of the eight models)	16 (8 × 2) models (dry/reverb.)
	6	introduction of long silences through dynamic filtering according to global transformation processes (with two different real-time versions for each model)	32 sequences

<i>stages</i>	<i>steps</i>	<i>devices, settings and manipulations</i>	<i>intermediate results</i>
realisation of a version	7	sequences must be joined by common parametric situations to realise an absolute continuity (so that shifts in character occur within the sequences, but not as a signal for transition from one sequence to another)	
	8	dynamic variation during recording session or performance	

The four parameters (the two steps of reverberation, necessarily separated during the production, but fusing into one single quality once the sequences were finished, are considered as one) used in *Scambi* according to the successive stages of the realisation process thus interact in different ways. The average speed of the irregular impulses obtained through dynamic filtering of a white noise basis (from slow to fast) and the relative pitch (global site from low to high through filtering) are combined by mixing and splicing, while sonic homogeneity (from dry to reverberated) and continuity (from uninterrupted sound to long silences) result from later real-time processes on the basis of «models» submitted to variable transformations.

Example 3a: Table of the 32 sequences of material for *Scambi* (transcription of Pousseur's self-analysis – sketches for *Votre Faust*); 0 indicates the minimum (low, slow, etc.), 1 the maximum.

<i>Family</i>	<i>Sequence</i>	<i>Pitch</i>	<i>Speed</i>	<i>Homogeneity</i>	<i>Continuity</i>	<i>Duration</i>
1	1–2	0/1	1/1	1/0	0/0	42''
2	3–4	0/1	1/1	0/1	1/1	42''
3	5–6	1/0	1/1	0/0	0/1	42''
4	7–8	1/0	1/1	1/1	1/0	42''
5	9–10	1/1	1/0	1/0	1/0	30''
6	11–12	1/1	1/0	0/1	0/1	30''
7	13–14	1/1	0/1	0/0	0/0	30''
8	15–16	1/1	0/1	1/1	1/1	30''
9	17–18	0/0	0/1	1/0	0/1	30''
10	19–20	0/0	0/1	0/1	1/0	30''
11	21–22	0/0	1/0	0/0	1/1	30''
12	23–24	0/0	1/0	1/1	0/0	30''
13	25–26	1/0	0/0	1/0	1/1	42''
14	27–28	1/0	0/0	0/1	0/0	42''
15	29–30	0/1	0/0	0/0	1/0	42''
16	31–32	0/1	0/0	1/1	0/1	42''

Example 3b: Variable degree of parametric changes within the sequences of *Scambi* (per family).

Number of parametric changes per family	
1 change	7-8-11-12
2 changes	1-2-3-4-13-14-15-16
3 changes	5-6-9-10

The above tables are transcriptions of the corresponding «sketches» contained in the dossiers relative to *Votre Faust*. They show the respective end situations in each parameter and thus allow the overall multiparametric evolution process for each pair of processes to be deduced. As in the production process, both parameters, speed and pitch, were associated to produce the four models afterwards submitted to further treatments, it is not important that in his auto-analysis, Pousseur places pitch as the first column.

The resulting 32 sequences (in fact 16×2 , that is to say 16 sequences with different parametric evolutions with always two different versions of each process – see Pousseur’s letter) are conceived in such a way that the multiparametric end situations obtained only feature eight of the 16 possible combinations. Such a limitation was rooted in Pousseur’s formal intentions and gave thus rise to the only rule for connecting the sequences when realising a version: this rule calls for joining the sequences through identical parametric situations. The fact that the end of one sequence is globally identical to the beginning of the next guarantees that each realisation, independent of the specific order of the chosen sequences, would always display a continuous flow that could be split into diverging processes or could converge to a common character after independent evolutions (because of the limited number of connection situations, it is of course possible to continue a single sequence by two other sequences, diverging with respect to their parametric transformation). Furthermore, within the longer processes with inner transformational reorientations resulting from such a succession of sequences, specific situations can be locally identified while the moment of transition between the sequences cannot be determined when listening to the result.

Example 4: Multiparametric situations that were selected among the total number of possible combinations (transcription of Pousseur’s self-analysis – sketches for *Votre Faust*).

Pitch	1	1	1	1	0	1	1	1	0	0	0	1	0	0	0	0
Speed	1	1	1	0	1	1	0	0	1	1	0	0	1	0	0	0
Homogen.	1	1	0	1	1	0	1	0	1	0	1	0	0	1	0	0
Contin.	1	0	1	1	1	0	0	1	0	1	1	0	0	0	1	0
Selected sequences	*			*		*			*	*		*		*	*	

Pousseur himself realised two different versions at that time, one longer, the other shorter, and he privileged the longer one for publication on records. The reconstruction of the sequence choice within this version makes his formal intentions explicit, including the polyphonic ramifications and their consequences. At its end, the initial sequence is followed by two sequences sharing the same starting point, and three sequences later both divergent processes join again into a similar parametric situation, thus resulting in one common goal sequence. Later in this version, Pousseur enhances the polyphonic density from two to four simultaneous processes, the whole evolution increasing and decreasing symmetrically. During the first ramification, the connection points between sequences within each process do not coincide even if the global length of the respective three sequences is identical: this asynchronicity of the parametric reorientations raises the intention of continuous flow within the multiparametric framework to a higher level, avoiding all kinds of formal markers as usually achieved through the category of contrast. Contrasts only exist between the characteristic situations chosen as endpoints and are thus always the result of a transformational process, never of a formal dramaturgy, shifting suddenly from one position to another to challenge or irritate the listener.

Example 5a: Reconstruction of the sequence succession in Pousseur’s long version (identification of the sequences with polyphonic superposition).

0	30	60	90	120	150	180
	4	8	24			
6					17	
	22	30	28			

Example 5b: Reconstruction of the sequence succession in Pousseur’s long version (parametric changes).

0	30	60	90	120	150	180
	low fast ——— dry continue ———	high fast ——— echo ——— continue	low ——— fast echo ——— silences—	low slow echo silences		
high fast ——— dry ——— silences	low fast dry continue			low ——— low slow fast echo dry silences . . continue		
	low ——— fast dry ——— continue—	low slow ——— dry ——— continue	high slow ——— dry silences ———	low slow echo silences		

Example 5c: Reconstruction of the sequence succession in Pousseur's long version (number of parametric changes within each sequence).

0	30	60	90	120	150	180
	#2		#2	#1		
#2						#3
	#1	#2	#2			

In the early 2000s, John Dack organised the Scambi Project at Middlesex University (UK).³⁵ In this context, different new elaborations on the basis of Pousseur's material were realised as well as a game-like interface to produce versions on the basis of Pousseur's old rules. In discussions with John Dack and the students, the reflection was directed towards possibilities to expand Pousseur's rules. Taking into account the evolution of serial thought during the 1960s, namely Pousseur's own concept of *périodicité généralisée*, the only modification of the rules I could agree with is the introduction of a variable *degree of similarity* to connect the sequences (something very close to Stockhausen's *Veränderungsgrad*), that is to say the creative manipulation of a scale of differences between closest identity (Pousseur's historical rule) and contrast (which resulted in Berio's version, as he ignored Pousseur's indications), so that the inner variability and surprises within the sequences (the trajectory is never a straight one and the number of parametric changes is variable – see example 3b) would find a kind of correspondence at the higher formal level. With respect to the aesthetic idea, this would still conform to the initial intentions of the composer and would thus seem acceptable to me without resulting in a major reorientation of the work's conception itself.

4. Pousseur's *Rimes pour différentes sources sonores*: interactions between tape and instruments – with manual spatialisation of the tape

In the autopoetic reflections of composers involved in studio realisations at the end of the 1940s and the first half of the 1950s different considerations emerged regarding the relationship between studio-based sound production and live performing musicians. While in its beginnings, *musique concrète* defined itself as strictly opposed to instrumental music (the term *musique concrète* meaning composing immediately with and within the sonic reality instead of fixing symbols

35 John Dack's *Scambi Project* is still documented on a specific website (www.scambi.mdx.ac.uk, accessed on 8 December 2017).

to be later translated into sound by performers), Schaeffer answered a certain number of early reactions against *musique concrète* addressing as a specific topic the problematic absence of a human agent during concert performances. There were two almost immediate consequences: for pure tape compositions he designed devices like the «pupitre d'espace» allowing a real time distribution of the recorded signal on different speakers according to the movements realised by a human performer standing inside of an electromagnetic field; for his *Orphée* project, he combined tapes and live performers.³⁶

In the serial exploitation of electroacoustic means, first of tape splicing, then of synthetic sound building, the new role of musicians was quickly considered as complementary to what could be achieved in a studio production.³⁷ The prevailing conception of combinations between these two «dimensions» (to quote Maderna) was therefore one of timbral complementarity, the recorded sounds completing and enlarging the chosen instrumental sounds beyond their organological limits. This position is shared by Pousseur in his *Rimes pour différentes sources sonores* (1958–9), Stockhausen in his *Kontakte* (1958–60), Maderna's *Musica su due dimensioni* (1958 version), Berio's *Différences* (1959) or Boulez's *Poésie pour pouvoir* (1958).

When Pousseur began working on *Rimes* (the premiere of a first part had to take place in the spring of 1958), he intended to go beyond previous attempts to combine instrumental sounds and tapes, especially Maderna's *Musica su due dimensioni* (1952 version) and Edgard Varèse's *Déserts* (1954), both consisting basically of the alternation of the live playing and sections fixed on tape. Pousseur thus conceived both strata for a simultaneous performance, using, on the tape, both recorded and distorted instrumental sounds as well as electronically generated ones. Aesthetically, he expected to create different kinds of interactions between the different sonic materials, the idea of expanding the limits of instrumental music in different directions being his central preoccupation. One such expansion was the diversification of the sounds' spatial origin.

As explained by the composer in his introductory text to *Rimes*,³⁸ the first movement was intended as a mere demonstration of the interaction between the

36 Marc Battier, «Recent Discoveries in the Spatial Thought of Early *Musique concrète*», in: Martha Brech and Ralph Paland (eds), *Kompositionen für Hörbaren Raum. Die frühe elektroakustische Musik und ihre Kontexte. Compositions for Audible Space. The Early Electroacoustic Music and its Contexts*, Bielefeld, transcript Verlag, 2015, pp. 123–136.

37 Stockhausen, for example, began a new cycle of *Klavierstücke* immediately after having completed his *Studie I* in November 1953, and elaborated in the following years his concept of a «new instrumental music» culminating in *Zeitmaße* (1955–6), *Klavierstück XI* (1956) and *Gruppen* (1955–8).

38 An until recently unknown longer version of Pousseur's introductory text to *Rimes*, as well as other transcriptions of relevant and unpublished material from the Pousseur Archive are given in the appendix of this publication.

instruments and the tape. At the beginning, recorded instrumental sounds join the orchestra; they progressively undergo different transformations but still originate from the same spatial position (i.e. the loudspeaker placed behind the main orchestra). Progressively, the recorded sounds also appear in the rear speakers, defining the complete physical space of the performance before shifting to proper electronic sounds, which tend to become predominant in the balance between the sound sources and finally provoke the orchestra's silence. The way back from the noisy electronic sounds combines a clarification in the recorded sounds by a shift towards sinewave complexes with the recovering of the instrumental parts.³⁹

For the performance, each part of the composition requires different sonic means: in the first part, only the main front orchestra plays; in the second and third movements, this orchestra is augmented by two instrumental groups placed at the back corners of the performance space. The tape participates only in the two first movements, the loudspeakers being initially connected with the placing of the instrumental groups. In the newly installed Brussels studio the tape could not be produced in a multi-track format, so the spatial repartition onto the three loudspeaker groups is specified in the score and must be realised live during the performance on the basis of a mono tape. While the performing indications are quite clear for the first movement, there is a complete lack of instructions concerning the spatialisation within the second movement.

For a performance to take place in Turin in 2006, Pousseur reconsidered the tape part together with the staff of the Tempo Reale studio in Florence. Besides a slight improvement of the proper sonic quality of the tape (careful reduction of the tape noise), the spatial dramaturgy was now fixed within an eight-channel setup, the loudspeakers surrounding the audience in a circle, but each speaker being coloured differently (with a different frequency peak for each loudspeaker). With respect to the tape, the concert performance aspect has thus now been reduced to the balancing of the different live and recorded sound sources. Further details are provided in the following contribution by Kilian Schwoon.

39 Henri Pousseur, *Écrits théoriques 1954–1967*, cit., pp. 162–163.

The revision of Henri Pousseur's *Rimes* at Tempo Reale

The longstanding friendship between Luciano Berio and Henri Pousseur has been of crucial importance to both composers, especially during the Studio di Fonologia years, when they were discussing and exploring the potential of new musical means, including the new electroacoustic technologies. In later years, too, their mutual appreciation was evident. In 1987, Berio had founded Tempo Reale, an institute in Florence dedicated to music research, production and education, with a focus on live electronics. At the end of the 1990s, he spoke several times with Francesco Giomi (at that time scientific and musical coordinator, nowadays director of Tempo Reale) about the possibility of performing *Rimes pour différentes sources sonores* (1958/9). He considered this piece, which Pousseur had dedicated to him and Bruno Maderna, as one of the outstanding early achievements in combining instruments and electronics. Unfortunately, such a performance could be realised only after Berio's death. Pousseur came to Florence for a «musical encounter» in 2004,¹ and on that occasion, he discussed the idea of a new version of *Rimes* with the Tempo Reale team. This «version régénérée», as Pousseur later called it, was developed under his guidance during the following almost two years, and had its premiere in 2006 at the Festival RAI Nuova Musica in Turin.²

Pousseur was very interested in reviewing the spatialisation of the tape and outlined the basic ideas in an e-mail:

You know that the original tape was mono, and that I distributed it on a triangle of loudspeakers: one in front, central, as coming from the middle of the orchestra, and two more or less in the back corners (in the first part, which was first performed alone, in October 58, these were the only «sources» at other places as the stage; then, for the second part, which I composed after the first had [already] been played several times, and which was first perf. in the summer of 59, I added the other groups of instruments, AND AS OFTEN AS POSSIBLE, WE PUT THE TWO [SEXTETS] (only strings and winds – as on stage there are only strings and percussion) AS MUCH AS POSSIBLE ON THE SIDE, BETWEEN THE MAIN ORCHESTRA AND THE REAR GROUP (only [keyboards] and percussion); So, if we can do something similar in [Torino], it would be fine). Then the third part keeps the spatial dimension well

1 *La parabola del suono*, Studio C, Rai di Firenze, 5 June 2004.

2 Concert of the Orchestra Sinfonica Nazionale della RAI, Auditorium «Arturo Toscanini» di Torino, 24 March 2006; conductor: Pascal Rophé; artistic director of RAI Nuova Musica: Daniele Spini; Tempo Reale: Francesco Giomi, Damiano Meacci, Kilian Schwoon; see also Henri Pousseur, *Rimes pour différentes sources sonores* (1958/59). *Version régénérée* (2005). Program note [from the estate of Henri Pousseur].

opened to [compensate] the lack of electronics in the third part (the creation had to be in November in Donaueschingen, I had no time to make a new tape, and it seemed to me that it could be a positive way of answering this lack: the two exterior parts having each its own «selection» of the 2nd part's total means[]). [...]

Naturally, we must have more than three loudspeaker-sources. 4 seems to me a minimum (each in a corner of the hall – not extremely far, of course; but 8 would be better and more interesting (for instance a sort of [octagon] in which the square or rectangle of the hall has «cut angles»). [...]

Now, [...] just a very general principle, that we can very much [refine] when I know more precisely the possibilities:

In the first part, the tape-sound emerges gradually from the orchestra and progresses toward the rear wall (and the whole space) as is shown roughly by the indications in the score; then, from the end of p. 19, there is no more indications, and I think to remember that I brought it [gradually], playing with the two sides, again to the main stage, that means in front of the audience.

In the 2nd part, on the contrary, I began with the rear for the tape alone, which poco a poco took possession of the whole space, so that the first instrumental interjections appeared inside of this «sound-pool». [Then] I played a (relatively long time) with the various spacial locations until I got to a total space again for the «climax» (where tape and orchestra have this sort of «fire-work explosion» described in the text, with the gradual dissemination, rarefaction and slowing down. And I finished in the front, to have a contrast to the finishing solo-marimba in the back []).³

An octophonic setup could be provided in Turin, and Pousseur opted for a rather large circle of loudspeakers, surrounding not only the audience, but also the musicians on stage. In fact, the front loudspeaker in the original version was already placed behind the musicians (Figure 1). Such a setup allows a strong sense of immersion to be created in a space defined by both instrumental and electronic sources.

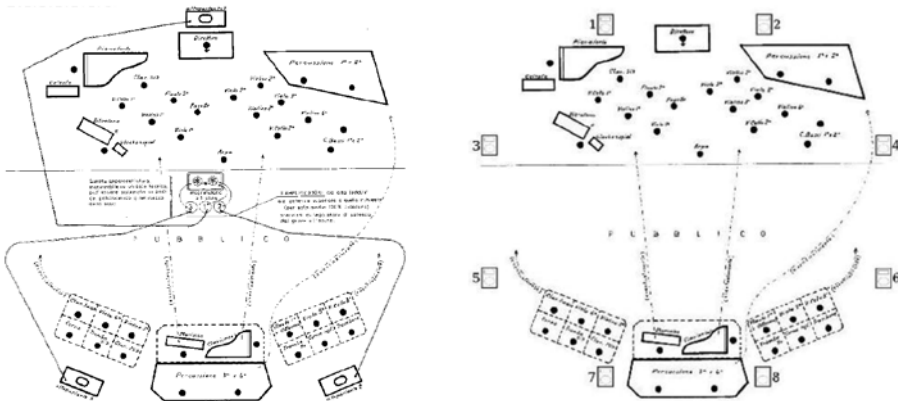

Figure 1: Comparison between the original (left) and the new loudspeaker setup. Reproduced with kind permission, © by Sugarmusic S.p.A. – Edizioni Suvini Zerboni, Milan, Italy.

3 E-mail to Francesco Giomi, 17 October 2005.

In many aspects, the work carried out in Italy was indeed a «refinement» of the historical version. The original mono tape had been digitised (in cooperation with the RAI in Milan) and slight noise reduction was applied. This was difficult due to the noisy nature of the recorded material itself. Tests with the unaltered version had shown a particularly annoying effect of moving tape hiss, so a very careful noise reduction was chosen.

Originally, the mono tape had been spatialised manually by modulating the amplification of the three signals sent to the loudspeakers. Up to a certain point,⁴ these movements were indicated in the score with numbers, dynamic marks and arrows (some examples are provided in Figure 2). But even such indications left a certain freedom to the performer, especially when arrows just suggest some kind of interplay between the loudspeakers. These movements were now mapped onto the higher number of loudspeakers, basically with the same principle of simple amplitude modulation. The eight-channel setup allowed for more continuous transitions, but also for variations between more focused or wider positions at the same angle, by distributing the sound over various loudspeakers.

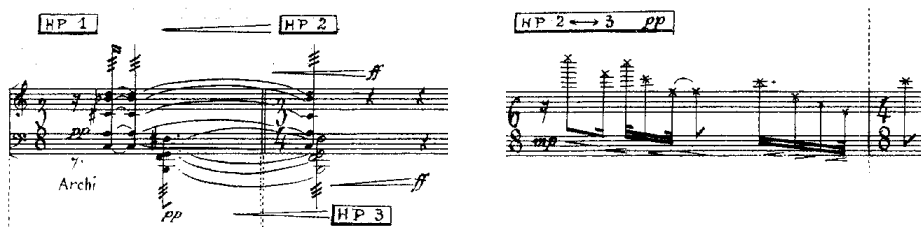

Figure 2: Two examples of notation of manual spatialisation in the original score (p. 3, 7). HP stands for «haut-parleur» (loudspeaker). Reproduced with kind permission, © by Sugarmusic S.p.A. – Edizioni Suvini Zerboni, Milan, Italy.

Another «refinement» involved dividing the mono tape into two signals focusing on lower and higher frequencies (by means of lowpass and highpass filters) and spatialising them separately. Though the basic movements were very similar, sometimes the lower frequencies were, for instance, distributed on more loudspeakers, or had slightly different speeds of movement, etc. These strategies led to a richer and more differentiated spatiality, overcoming the impression of a single sound source being moved.

Furthermore, particular algorithms were used in order to create randomised movements. The first type of algorithm generates relatively fast random movements within certain areas, with irregular times of stasis and crossfade. For

4 Actually, the last indication is on p. 16, not on p. 19, as Pousseur had written in his e-mail.

example, the movements «2↔3» on pp. 5–8 were replaced by irregular random movements, mostly on loudspeakers 5 and 6 and, by means of weighted random, occasionally on loudspeakers 3, 4, 7 and 8. The second type of algorithm generates circular movements with a constant speed and irregular changes of direction. Such movements provide a strong continuity, but without a real sense of rotation. They were applied, for instance, in the crescendo part on pp. 16–17, and in section D of the second movement. These randomised movements also sometimes differ between low and high frequencies. Superpositions of movements and transitions between different layers of movements finally create a veritable spatial polyphony in some moments. The spatialisation system developed at Tempo Reale is purely amplitude based, but it provides certain parameters to adjust the envelope shapes applied to the various channels.⁵ This allows the sharpness of the spatial articulation to be modulated, which has been done carefully in this case together with the composer.

The resulting eight channels were recorded and are now distributed in this fixed form by the editor Suvini Zerboni. While in this version the spatial movements don't require an «interpretation» any more, nevertheless, some individual adjustments have to be made for every performance. To further enrich the spatial experience, Pousseur had defined a series of filter frequencies that should slightly «colour» each loudspeaker (Figure 3). This should be realised differently in each concert hall by applying bandpass filters to the eight channels, taking into account the resonant characteristics of the hall. Pousseur had initially considered some spatialisation of the live instruments, especially in the third movement. In the end, he found that unnecessary, so that only the amplification of the harpsichord is mandatory. A slight amplification of other instruments is possible, depending on the acoustics of the hall. The overall balance between instruments and electronics remains an important task for the sound director and needs to be adjusted throughout the performance.

5 Francesco Canavese, Francesco Giomi, Damiano Meacci, Kilian Schwoon, «Asymmetrical Envelope Shapes in Sound Spatialisation», in *Proceedings of the Fifth Sound and Music Computing Conference (SMC 2008)*, Berlin, pp. 41–45.

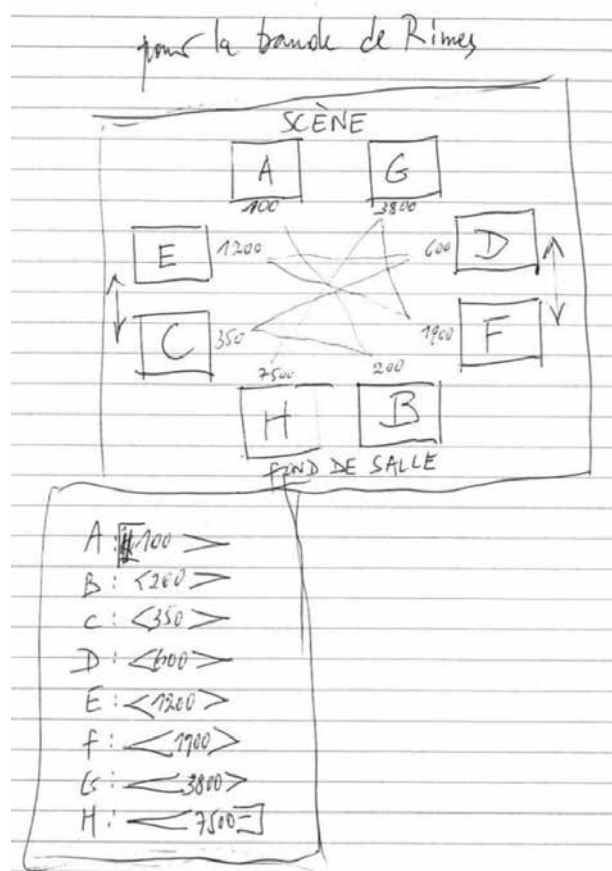

Figure 3: Pousseur's sketch of the distribution of filters for the various loudspeakers. Reproduced with kind permission of the Tempo Reale archive, Florence.

For Pousseur, this «version régénérée» was the definitive one.⁶ At a talk in Cologne in 2006, he even mentioned that the piece had actually «sounded completely new» in Turin.⁷ For a historically informed performance practice, it might be helpful not to forget the original version and Pousseur's own description of the manual spatialisation he did with just three loudspeakers, documented in the e-mail to Tempo Reale above.

6 Henri Pousseur, *Rimes pour différentes sources sonores (1958/59). Version régénérée (2005)*. Program note [from the estate of Henri Pousseur].

7 Henri Pousseur, «Erinnerungen an Luciano Berio», in *Topographien der Kompositionsgeschichte seit 1950*, ed. Tobias Hünermann and Christoph von Blumröder, Wien, Der Apfel, 2011, p. 6.

Auctorial Tradition and Contemporary Practice: Performing *Musica su due dimensioni* by Bruno Maderna

Introduction

The following essay elaborates on the general ideas outlined in the introduction to this book about the problematic of electroacoustic performance practice today by taking a closer look into two issues related to specific works composed at the Studio di Fonologia della RAI Milano: the different kinds of dissemination channels leading to different formats and variants and the traces of auctorial performance traditions. The last question will be studied using the example of *Musica su due Dimensioni* (1958) of Bruno Maderna based on the comparison of three early recordings of the piece and two different sets of performance materials. This will be confronted with our own experience performing the piece in two concerts and one recording following an approach developed within the scope of the projects that led to this publication. This approach, which was first tried prior to reading a paper on the same subject by Marco Gasparini,¹ resonates strongly with his own. The comparative part can therefore be seen as a complement to his paper based on the analysis of further historical sources. A historical contextualisation of the piece concerning the question of open form can be found there. The last part of this text discusses in detail our performance practice for which the recording became an ideal subject because it forced us to render a fixed version of a work conceived to be different each time, thus making it possible – as Maderna's historical recordings do – to expose it to critical review.

1 See Marco Gasparini, «Un campionatore per *Musica su due dimensioni* di Bruno Maderna», in *Atti del XVII Colloquio di Informatica Musicale*, Biennale di Venezia, Radici Futuro, 2008, pp. 103–107.

What is the work?

There exist today different practical difficulties and musical challenges with respect to the concert performance of works produced at the Studio di Fonologia between 1955² and 1983. Many pieces exist in different versions and mixes. They were made for numerous purposes: pre-mixes made during the composition process, radio broadcasts, concerts, talks, record and CD editions. The first question raised when performing a piece in concert therefore concerns the piece itself. Is there a clearly identifiable concert version? If an authorised concert version exists, is it really the best choice? Under what circumstances can it be substituted? If there are several concert versions, according to which criteria can the performer choose? The performance materials provided by editors do not always clearly answer these questions; their critical review by the performer is mandatory. In order to grasp the complexity of this issue with respect to the pieces we are dealing with it is necessary to consider the compositional practice at the Studio di Fonologia at the time, as well as the different distribution channels of these works over the following decades.

The works composed at the Studio di Fonologia were also intended for radio broadcasts, if not exclusively, even if a transmission could not always take place right after a work was completed. Examples of this are Berio's *Thema (Omaggio a Joyce)*, which was broadcast only after a delay, and *Visage*, which was censored for its content and broadcast only some 10 years later.³ Whatever the intended final format was, a mono mix was made for broadcast transmission. Other studios as well used to present electronic works in radio programs. The first *Musique Concrète*⁴ works were broadcast in Pierre Schaeffer's program *Club d'Essai* starting in 1948, while the first traces of concert performances can be found only in the early 1950s.⁵ Gottfried Michael Koenig for his works *Klangfiguren II* (four-channel, 1955/6), *Essay* (mono, 1957/8) and *Terminus I* (four-channel, 1962) quotes the broadcast dates on NWDR as first performance dates.⁶

2 The year when the Studio di Fonologia was officially founded, although *Ritratto di Citta*, the first collaboration between Berio and Maderna, had already been made in late 1954. See Nicola Scaldaferrì, «Montage und Synchronisation», in: Elena Ungeheuer (ed), *Elektroakustische Musik*, Laaber, Laaber Verlag, 2002, pp. 66–82 (*Handbuch der Musik im 20. Jahrhundert*, vol. 5).

3 See Maria Maddalena Novati and John Dack (eds), *The Studio di Fonologia. A musical journey. Update 2008–2012*, Milano, Ricordi, p. 178.

4 See Évelyne Gayou, *GRM, le Groupe de recherches musicales: cinquante ans d'histoire*, Paris, Ed. Fayard, 2007, pp. 73–78.

5 The first concert sound projection of electronic music in Paris using potentiometers was realised by Pierre Henry in 1951 (see note 4).

6 See Gottfried Michael Koenig, *Ästhetische Praxis*, Vol. 3, Saarbrücken, Pfau Verlag, 1993, pp. 91, 92.

Of course, composers working at the Milan studio were, from the beginning, also thinking of concert performances, and this is documented by mixes for non-broadcast formats such as two- and four-channel. The highlight of the Studio di Fonologia's inauguration on 8 May 1956 in Milan were concert performances of works by Maderna, Berio, Schaeffer, Henry, Stockhausen and others.⁷ Maderna's *Notturmo* and Berio's *Mutazioni* (both from 1956) were presented in Darmstadt the same year. The concert series *Incontri musicali*, organised at the Milan conservatory from 1956 onwards, became an important forum for the dissemination of electronic music made at the Studio di Fonologia. A concert presenting new works by Berio (*Perspectives*), Maderna (*Syntaxis*) and Pousseur (*Scambi*) took place in early 1957 in Zurich under the technical direction of Alfredo Lietti and was repeated in Darmstadt the following summer.⁸

As in other studios run by European broadcast companies in Paris and Cologne, the four-channel format was established in Milan alongside the mono format as a working and concert format in the early 1960s.⁹ The four-channel format was used as a concert disposition for works containing spatial, polyphonic structures, but it was also an important format for studio work. It allowed for more complex montage techniques and was often used as an intermediate step preceding a final mono or two-channel mix in order to achieve a better signal-to-noise ratio. For this reason, it is not always possible to unambiguously determine the initially intended concert format, for example mono or four-channel. A good example of this is Luigi Nono's *Omaggio a Emilio Vedova*. While performance practice using multi-track machines was still not implemented at the Studio di Fonologia in 1960, concert performances of the piece using the four-channel version actually distributed by the publisher have proven to be musically very effective.¹⁰

Nevertheless, all three formats, mono, two-channel and four-channel were soon used in concert. The tapes marked «Q», held at the Archivio di Fonologia,¹¹ indicate that four-channel tapes with specific orders of works were prepared for use in concert. It was only in 1961 that the RAI obtained portable four-channel players for use in concert, so works such as *Thema (Omaggio a Joyce)* in their four-channel

7 See Nicola Scaldaferrì, *Musica nel laboratorio elettroacustico*, Lucca, Libreria Musicale Italiana, 1997, p. 70.

8 Nicola Scaldaferrì, *Musica nel laboratorio elettroacustico*, cit., p. 75.

9 *Momenti* by Berio and *Omaggio a Emilio Vedova* by Nono were both composed in 1960 using a four-channel tape machine. See Nicola Scaldaferrì, «Montage und Synchronisation», cit., p. 74 (cf. note 2).

10 For a further discussion of this issue see Alvisè Vidolin's contribution «Sound direction of 1950s and 1960s tape pieces from the Studio di Fonologia», p. 116.

11 See Maddalena Novati, «Studio di Fonologia RAI 1955–1983», <http://fonologia.lim.di.unimi.it/bobine.php> (last accessed 8 December 2017). The first quadrasonic tape (Q001) contains the following pieces: Niccolò Castiglioni, *Divertimento*; Luciano Berio, *Momenti*; Luigi Nono, *Omaggio a Emilio Vedova*; Camillo Togni, *Recitativo*; Roman Vlad, *Ricerca elettronica*; Bruno Maderna, *Serenata 3^a*; Gino Marinuzzi Jr., *Traiettorie*.

versions had to be played using two synchronised two-track tape machines.¹² In order to avoid this problem in concerts or lectures, two-channel mixes of four-channel works were also used.

Furthermore, two-channel mixes of multichannel pieces were first made in the 1970s for record editions. Restorations made together with composers in the context of digitisation efforts in the 1990s also led to new versions, often subsequently used by the composers in concert because of their enhanced sound quality or for practical reasons. Such versions can be regarded as last authorised versions. A good example of this is *Thema (Omaggio a Joyce)*.¹³

Because of all these factors, sometimes considerable numbers of versions exist for some pieces. For example, a list of the existing sources for *Omaggio a Emilio Vedova* includes not less than six four-channel versions, five two-channel versions and three disc releases. Which one should be used in concert? The editor provides a restored four-channel version as performance material. There are reports of performances of a two-channel version by Nono.¹⁴ Performers such as Alvisse Vidolin believe it to be a mono piece. An objectively unambiguous answer to the question of a sole valid concert format can hardly be given.

Performance traditions

Notwithstanding their common roots at the Studio di Fonologia, we can see different approaches to performance practice among composers such as Berio, Maderna and Nono. This may have been due to their different aesthetic views and personalities. Their individual involvement in performance practice also varied.

As several contemporary witnesses report, Luigi Nono took a decidedly performative approach to sound projection in connection with a clear definition of sound sources that could, however, be adapted to fit specific concert spaces. The clear definition of channels and speaker positions as well as their differentiated modulation on the master tape did not keep Nono from reacting to spatial and technical conditions. He would adapt the speaker disposition and in concert creatively work

12 In 1958 there was no four-channel tape machine at the Studio di Fonologia. *Thema (Omaggio a Joyce)* was composed using two synchronised two-channel machines. See Nicola Scaldaferrì, «Montage und Synchronisation», cit., pp. 72–74.

13 See also Alvisse Vidolin's contribution «Sound direction of 1950s and 1960s tape pieces from the Studio di Fonologia», p. 116, where he proposes a different interpretation of the piece's intended format.

14 See Giovanni Caprioli, *Indagine filologica e analisi di < Omaggio a Emilio Vedova > (1960) per nastro magnetico solo di Luigi Nono*, graduation thesis, Università di Pavia, Facoltà di Musicologia, 2007, p. 87.

with and expand the dynamic spectrum, interacting with the space, the performer(s) and the public. Even in multichannel works, the overall dynamics as well as the relative dynamics of the individual channels were manually controlled in concert, as can be seen, for example, in the performance score for *La fabbrica illuminata*.¹⁵

Thema (Omaggio a Joyce) by Berio presents an interesting challenge to performers because of its musical structure and history. On the one hand, its polyphonic structure appears to us to mirror this structure in the sound projection. In that respect, the early four-channel version, formerly used by Berio himself, seems to be the performance material of choice. On the other hand, we know that Berio in later years made a point of carefully reproducing the edited stereo version over multiple speaker pairs,¹⁶ which makes a return to the original four-channel version not entirely unproblematic because the stereo version also has shortened pauses. There are no reports by former collaborators suggesting that Berio would massively manipulate the dynamics or the spatial projection of tape works at the mixing console. When performing works with live electronics in later years, he would leave the concert sound projection to the musicians of *Tempo Reale*.¹⁷

Bruno Maderna's *Musica su due dimensioni* raises completely different questions with respect to performance practice. Due to its conception as open form, its formal consistency is to a great extent defined by the performers. Three recorded historical performances from Naples, Darmstadt and Cologne reveal significant differences with respect to the time structure and the use of the tape. They document Maderna's early performance practice as well as his understanding of the electronic medium as dynamic and listener oriented.¹⁸ Because of his early death, there are otherwise only few documents or reports shedding light on his approach to performing his electronic music.

Can we today, for example, distance ourselves from the later practice of Berio and realise the polyphony inherent in *Thema (Omaggio a Joyce)* by using the original four-channel version or by using the two-channel version for a dynamic sound projection? Is it justifiable to interfere with the relative dynamics of a four-channel piece according to a given situation? In Maderna's *Musica su due Dimensioni*, are we allowed to increase the tape's variability using current software to make tape fragments immediately available, allowing for spontaneous decisions during the performance?

15 See also Alvisè Vidolin, «Sound direction of 1950s and 1960s tape pieces from the Studio di Fonologia», p. 116.

16 BMG Release 1995 (BMG 09026-68302-2).

17 Information from Kilian Schwoon, 15 April 2015.

18 See Bruno Maderna, «Expérience compositionnelle de musique électronique: Conférence, 26 juillet 1957, Internationales Musikinstitut Darmstadt», in: Philippe Albèra, *Musiques en création : Textes et entretiens*. Genève, Éditions Contrechamps, 1997, pp. 131–132 (online: <http://books.openedition.org/contrechamps/1256>, accessed on 8 December 2017, and Angela Ida De Benedicti's contribution, «The beginnings of the Studio di Fonologia Musicale and Bruno Maderna's *Notturmo*» pp. 28–29.

The answer to this is simple and difficult at the same time. Of course we are allowed to do these things. In many cases, we don't even have a choice but to do them. The conservation of a specific practice can only seemingly be successful because we always find ourselves confronted with a different aesthetic situation, the sum of material, spatial, technical, perceptive and cultural conditions that make conservation impossible or only partially possible or meaningful. Each time, the work has to undergo the process from moving from its existence as a tape to sounding matter. While the work is fixed as a signal that itself is always only an incomplete basis for its musical experience, it is the performer's task to start this process through aesthetically and technically motivated decisions and to complete what is left open according to his best knowledge and using the appropriate means.

However, the question will be difficult to answer as soon as we want to do justice to the work's origin and the author's intentions, inscribed into a more or less evolved performance tradition, intentions that we know to varying degrees according to available sources and reports for a given work, and that we can in many cases only guess at. With composers whose approach to the performance of a certain work has changed over time or has been adapted to certain conditions or situations, we also need to be careful about wanting to define a specific, canonical performance. We can always find exceptions. Even composers defining performance conditions and techniques with utmost precision, such as Stockhausen, have allowed for deviations in certain conditions. Examples of this are the permission to play the stereo tape of *Kontakte* over four loudspeakers if the channels are crossed, or an acousmonium version of *Oktophonie* realised by Françoise Bayle.¹⁹ In any case, thorough knowledge about all known aspects of a work and its authorial performance tradition is necessary in order to make and aesthetically justify alternative decisions. This is exactly the goal of the following remarks on Bruno Maderna's *Musica su due dimensioni*.

Musica su due dimensioni²⁰

The score of *Musica su due dimensioni*, published 1960 by Edizioni Suvini Zerboni,²¹ contains six manuscript pages and a typewritten explanatory note. For the first section, added after the performance in Naples, a different paper was

19 Information from Lelio Camillieri during the second Fonologia Workshop at Tempo Reale, Firenze, 6–7 December 2012.

20 Bruno Maderna, *Musica su due dimensioni, per Flauto e Registrazione Stereofonica*, Milano, Edizioni Suvini Zerboni, 1960.

21 Concerning the differences to *Musica su due dimensioni* (1952) see Nicola Scaldaferrì, «*Musica su due dimensioni* (1952). Histoire, vicissitudes et importance d'une œuvre (presque) absente», in: Geneviève Mathon, Laurent Feneyrou, Giordano Ferrari (eds), *À Bruno Maderna*, Vol. 2, Paris, Ed. Basalte, 2009.

used, suggesting that probably existing manuscripts of parts II–V were used and no fair copy was explicitly produced for the edition. This may become relevant if looking for traces of the initial concept of the piece in early manuscripts. The following explanatory note was probably added for the publication and reflects the experience gained through various performances:

La parte registrata (I Sezione) che inizia alla fine della prima parte del flauto, deve continuare, da sola, per un minimo di 30" fino ad un massimo di 2', a seconda delle condizioni ambientali e acustiche.

La II parte del flauto ha inizio a metà o verso la fine della I Sezione della registrazione, continuando da sola.

Tutte le parti successive s'intrecciano ad libitum, secondo l'interpretazione del solista e secondo le già menzionate condizioni acustiche e ambientali.

La III parte di flauto solo può essere eseguita interpolando ed anche ripetendo i vari frammenti, con esclusione di quelli posti tra parentesi, che dovranno essere eseguiti una sola volta.

Lo stesso dicasi per la V parte (Flauto solista) che non ha frammenti posti tra parentesi e che quindi possono essere tutti ripetuti ad libitum.

Arrivato alla V parte, il solista può interpolare i frammenti di questa parte con quelli della III, escludendo però, di quest'ultima, i frammenti posti tra parentesi. La ripetizione di questi frammenti non può essere che alternata, vale a dire che lo stesso frammento non deve venire ripetuto immediatamente, ma solo dopo una serie di frammenti diversi.

Tutta l'esecuzione di questa composizione deve avvenire su una specie d'interpretazione bilaterale del solista e del tecnico, interpretazione che si può «inventare» di volta in volta.²²

The recorded part (I section) that starts at the end of the first part of the flute should continue alone for at least 30" and not longer than 2', depending on the spatial and acoustic conditions.

The II part of the flute starts in the middle or towards the end of the first section of the tape and continues alone.

All the following parts will be woven together ad libitum, according to the interpretation of the soloist and the already mentioned acoustic and spatial conditions.

The III part of the flute can be performed interpolating and even repeating different fragments, excluding those written in parenthesis, which should only be played once.

The same can be said of part V (solo flute), which has no fragments in parenthesis and therefore can be repeated ad libitum.

In the V part, the soloist can interpolate the fragments of this part with those of part III, excluding again those within parenthesis. The repetitions of the fragments should only be

22 See score, p. 2.

done by alternating them, that means, that a given fragment cannot be repeated immediately but only after a series of different fragments.

The whole performance of this piece should become a kind of bilateral interpretation of the soloist and the technician, an interpretation that can be «invented» each time.

The first two remarks define how the tape should be combined in sections I and II, but without specifying which tape fragments constitute the «first section». The second remark implies that the tape should stop at some point during section II, marking the end of the «first section». The time limits of the solo segment for this section (between 30 and 120 seconds) imply that its duration may be longer than those values in order to allow at least for a short superposition with the flute. Accordingly, the performers must decide which fragments will belong to it and must take decisions about starting points of both flute part and the tape fragments.

The third remark opens a wide field of interpretation about what the «following parts» are (which fragments, how long, in which order?) and the way they will be «woven together». The wording suggests the possibility of different combinations with a high degree of freedom («ad libitum»), perhaps including overlaying, omitting and presenting materials in different orders in analogy to the combination of flute fragments in sections III and V, explained in the following four remarks. Even the possibility of repeating tape fragments must at least be considered. The last remark emphasises the spirit of the piece, and was already implied in the third one: a «bilateral invention» suggests that both performers should have the possibility of taking decisions in dialogue with each other in order to render different results in each performance.

In the score, sections I, II and IV are marked with the terms «SOLO» or «FL. SOLO», and the III and V sections contain the indications «CON REGISTR. STEREOFONICA» and «FL. ET REG.» respectively. The indication «INIZIO REGISTRAZIONE» is written after the end of the first section. This suggests that sections I, II and IV should be played solo and only sections III and V should be played together with the electronic part. But this reading is in conflict with the second explanatory note, which explicitly asks to overlap the tape and the section II. As we will see, it also contradicts Maderna's early own practice witnessed in the recordings mentioned above of performances in Naples (1 June 1958)²³ and Darmstadt (5 September 1958),²⁴ where the first performance of the complete piece was given, and Köln (1959), all performed by Severino Gazzelloni.²⁵

23 Berio's *Thema (Omaggio a Joyce)* was first played in the same venue (Incontri Musicali), Berio was present. See Nicola Scaldaferrì, *Musica nel laboratorio elettroacustico*, cit., p. 81.

24 *Continuo* by Maderna and *Perspectives* by Berio were performed in the same concert. Nicola Scaldaferrì, *Musica nel laboratorio elettroacustico*, cit., p. 82.

25 Independently of the question of whether Maderna himself actively took part in the three performances or not, the auctoriality of the three different tape configurations used is highly plausible. After all, Naples and Darmstadt were the first performances of the preliminary and the definitive versions of the piece.

In Naples, the first part of the flute didn't yet exist. The indications for parts II to V included in the early manuscripts probably correspond with the first formal concept of the piece, consisting of two «closed» solo parts (II, IV) alternating with two open sections (III, V), made out of fragments and to be played together with the tape. In the recording from Naples, however, we also find a tape introduction that ends before the flute starts. The tape re-enters again in the last third of this initial solo part (section II). Only section IV was played completely without tape (see Figure 1). A difference in the quality of the noise background and a clear cut at the entrance of the flute raise the question of whether the tape introduction was added for the radio broadcast. The omission of pauses between fragments A and B and the slight overlapping of fragments B and C (see Table 1) may be further evidence. In any case, in the performance in Naples the first concept was probably slightly modified and the tape was assigned a more prominent role, as the manuscripts may suggest. This direction was clearly followed in the next performances, where the electronic sounds were used in all sections, still leaving solo passages for the flute in sections II and IV. The 1958 performance in Naples can be considered a preliminary version of a work on its way to a – albeit open – definitive form, as it was finally published in 1960.

The tape material available today for performance from the publisher consists of a series of fragments of different length and channel structure mounted together in a single file: mono signal (either the signal is mainly on one channel or equally panned on both) and two-channel (different signals in the left and right channels). Apart from restoration issues this material is identical in content and time structure to the original tape held by the Archivio di Fonologia, which in the following text will be referred to as «RAI». In the present study the tape was defined as consisting of 16 fragments labelled A to P (see Table 1 and Figure 1, top). A different grouping of fragments can of course be defined. The beginning of fragment E was exceptionally chosen here with a sound material not preceded by a silence, because it has a different temporal and spatial disposition in comparison to the fragmentary, erratic section D.

Table 1: Division in 16 fragments A-P. The effective length excludes pauses between fragments. Fragment D contains several short sounds and rests of different lengths. Fragment A is preceded by the announcement in Italian «Bruno Maderna, Dimensioni per Flauto, banda elettronica».

<i>Fragment</i>	<i>Start</i>	<i>Length</i>	<i>Effective length</i>
A	0'08,6"	11,6"	7"
B	0'20,2"	35"	33"
C	0'55,2"	28,8"	24"
D	1'24,0"	43,6"	42"
E	2'07,2"	39,1"	36"
F	2'46,3"	9,0"	3"

<i>Fragment</i>	<i>Start</i>	<i>Length</i>	<i>Effective length</i>
G	2'55,2"	35,4"	26"
H	3'30,7"	2'41,8"	2'39"
I	6'12,4"	15,0"	8"
J	6'27,4"	19,9"	13"
K	6'47,3"	12,3"	9"
L	6'59,6"	10,2"	3"
M	7'09,8"	1'07,0"	60"
N	8'16,8"	1'54,7"	1'40"
O	10'10,8"	27,4"	23"
P	10'38,2"	54,6"	52"

The materials used by Maderna in the tape consist mainly of pre-recorded single flute tones and figures as well as electronic sounds, some of them being repeated in different fragments. The electronic sounds have a wide morphological variety and include pitched and noisy impulses, gestures and textures in different registers and at different dynamic levels and with different spatial qualities. Sounds remaining voices are only heard once (fragment P). For the sake of an overview they can be divided in three main groups: In A, B, C, H and P flute sounds are predominant and include similar sounds and melodic passages; D, E and G contain rather quiet noise-like textures mainly and scarcely flute elements; I, J, K and L have single, clear and strong noisy resonating impulses which continue with higher density and complexity in fragments M, N and O. Fragments A-D and I-L are mono but only I, J and K are equally panned. In D there is practically no information on the right channel. The rest has a more-or-less pronounced two-channel structure.

The longest fragment, H, includes an excerpt of the recording of the Köln performance that starts at the end of the first section (third system, $a\flat^2$), includes the entrance of the tape and lasts until the end of section II. This excerpt was copied into channel two of RAI, starting at 4'04", and is combined with other electronic sounds in channel one that are closely related to materials included in fragments B, C and P. This indicates that the tape found its final structure after that performance in 1959. The fragments are separated by pauses of different length that can hardly be understood as musically measured articulations, rests, breaths or fermatas (see Table 1, difference between fragment duration and effective duration).

A comparison of the use of tape materials in the three historic recordings reveals a dynamic process of selection and recombination of materials that is completely consistent with Maderna's concept and practice of electronic music with respect to the realisation of the idea of open form.²⁶ While in RAI all fragments

26 For a contextualisation see Marco Gasperini, «Un campionatore per *Musica su due dimensioni* di Bruno Maderna», cit., pp. 103–107.

are separated by pauses, in the Naples performance, as mentioned above, the fragments A and B follow each other without pause, and fragment B even overlaps with fragment C. Different pauses between fragments compared with RAI can also be seen in Köln in fragments I to P, which follow each other immediately or after short articulations.

An additional set of tape materials, owned and used by Alvisse Vidolin, has also been examined in this study. It consists of two tapes labelled in Figure 1 as BER1 and BER2. The tapes were edited by Berio with the assistance of Vidolin and used by Berio in his own performances of the piece.²⁷ Apart from the sound quality and the fact that the channel layout is reversed, the structure of BER1 corresponds exactly to fragments B to I of RAI. Fragment A was omitted. BER2 however presents the remaining materials in a more compact way: fragments K and L were left out, N and P were shortened and the pauses between the four used fragments were reduced (see Figure 1). As we will see, Berio's approach in the second tape is quite consistent with Maderna's own practice.

Maderna changed the length of pauses and fragments in all three performances compared to the one finally included in RAI, as we can also see in Berio's tape. In Figure 1 all shortened fragments are marked (e.g. P' compared to the reference fragment P of RAI). In Köln we find tape material that was not used in the performances before. But Maderna not only shortened and combined materials differently in different performances. Like Berio, he also omitted some fragments (e.g. D, F, O and P in Naples, N and O in Darmstadt, A-D and F in Köln), occasionally changed the order (e.g. fragment P in all three performances) and, most importantly, combined them differently with the flute sections. We can thus assume that a larger set of materials was available, and that Maderna used a different selection each time. He even continued to expand this set with fragments of recordings.

Concerning the relation to the flute, the use of the electronic sounds contained in the left channel of fragment H in RAI is the most interesting case, because these materials appear in all three performances at different points and with different lengths: in Naples they were played after IV and overlapped to V. In Darmstadt, they were almost twice as long as in the other recordings, starting in the middle of IV and covering part of V. In Köln they were combined with fragment P (which contains similar high flute figures) and used as a transition between sections III and IV.

27 Information provided by Alvisse Vidolin. Each tape was meant to be played without interruption: BER1 after the first section, BER2 after the fourth. The tapes were finally made available to Alvisse Vidolin by Roberto Fabbriciani.

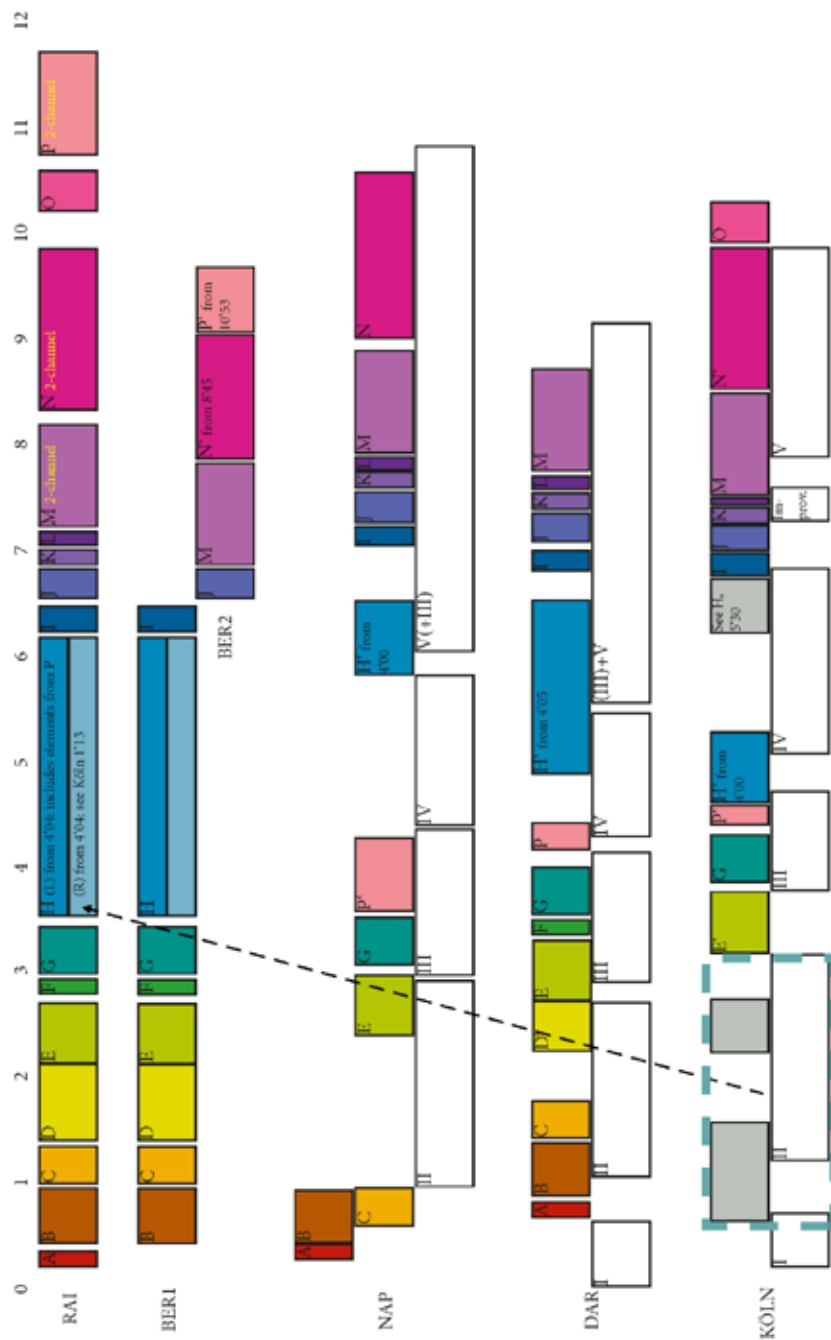

Figure 1: Representation of tape materials and historical recordings. The tape materials are from the Archivio di Fonologia (RAI) and Alvise Vidolin (Vidolin A and Vidolin-B/Berio). The recordings correspond to early performances in Naples (1958), Darmstadt (1958) and Köln (1959).

The major differences in the use of the tape fragments are found in Köln. For that performance Maderna not only omitted fragments A-D and F and shortened E, P and N but he also introduced new materials for the first appearance of the tape after the first part of the flute and within the second (see the area marked with a turquoise dotted line in Figure 1). As stated above, those materials found their way into RAI indirectly within the fragment of the recording integrated in the right channel of fragment H.

This last step has a major formal impact on the piece: the second section of the flute can be presented in its entirety for a second time if the corresponding part of fragment H is used. On the one hand this mirrors the repetition of flute fragments in parts III and V and their re-combination in V. Considering that H also contains materials found in fragments B, C and P, the recapitulation of section II expands a system of repetitions of materials in different musical contexts that increasingly blurs the initial linearity of the piece. On the other hand, it deepens the relationship between flute and tape and makes possible a dialogue with the flute part originally performed by Gazzelloni in Köln. This last point raises very important practical and aesthetical questions such as tuning (see below), the use of vibrato as well as the kind of articulation and dynamics preferred at the time, which belong to a specific historical and cultural context and may clearly differ from current practice and taste.²⁸

As far as the flute part is concerned, there are some differences between the performances and the published score. As mentioned above, the first part didn't yet exist in Naples. In the second part there are minor differences, for instance in the second and third lines of the second page (d¹ was played instead of e¹, a non-existing appoggiatura was played before the first b³). In the third part the last fragment played before part IV is not written in the score. In part IV there are several differences like additional repetitions in the third line, different single pitches as well as missing or additional single tones. In part V there is an additional closing fragment. Nevertheless, it can be said that in Naples the parts II to V were almost finished and that the piece was carefully performed in spite of these differences. They can perhaps be explained as intended or unintended deviations by the performer or as minor corrections in the edition.

The question of the tempi and the differences in the durations of notes and rests deserves special attention. The relatively slow tempo defined in Part II (eighth note = 60) leads to very long rests (e.g. almost 10" at the end of the first line, twice 6 seconds in the last line of the first page) and long notes (up to 6 seconds). The first line alone would last 26 seconds without taking into account the first fermata. In all recordings those durations have been reduced and adapted to the current context or even omitted, suggesting a high degree of freedom in the rhythmic realisation. This can possibly explain the lack of bar lines and metric structures. In

28 See Veniero Rizzardi's contribution, pp. 43–45, for a related issue concerning *Differences* by Berio.

Naples for instance, the long rest at the end of the first line was drastically reduced, Gazzelloni goes from the shortened d^3 (*sff* crescendo) directly to the e^1 (staccato with key click) in the second line leaving a rest of only about two seconds in between for the resonance of the high pitch. All longer rests in the following lines have been shortened, and some longer notes too (e.g. d^1 , f^1 , e^b2 in lines three and four, etc.). Nevertheless, a sense of the basic tempo is perceivable in most of the fast figures even if the last melodic sequence (last two lines of section II) was played at a noticeably faster tempo. The freedom in the time domain suggested by the notation and confirmed by the recordings gives the soloist the possibility to interact with the tape according to the last remark and is needed if we consider that in different performances different tape fragments can be played with a certain section. In Naples, for instance, the shortened fragment E was started on the second $f\#^3$ (second page, second line, *f* cresc.) and ended two seconds after the soloist. The duration of the final sequence was possibly adapted accordingly.

In the following parts III–V, no tempo markings are found in the score and the question arises of whether the tempo of the II section should prevail. In Naples, a similarly slow basic tempo (eighth note = 60) can be perceived in some fast figures of the III part (e.g. third line), but in general, longer durations and rests were played with a high degree of freedom. The fifth line for instance was played with a pronounced accelerando towards the last note. Incidentally, the last line of III was repeated immediately in a different variation with regard to durations.

As we have seen, the possibility of an immediate repetition is excluded in the print version. There are two interesting aspects to this. On the one hand it suggests that repetitions can be varied in the time domain. On the other hand, it suggests that Maderna may have reformulated his playing rules after gaining experience in early performances. In this context another observation has to be made: in Naples in III and V, in some cases only single elements of the flute fragments have been played, which is similar to the length alterations of tape fragments. This further fragmentation of materials is not explicitly addressed in the remarks, but still can be considered for a performance.

In the IV part of Naples, the solo flute is even more detached from a basic tempo. The general pace suggests a faster tempo, but strong compressions and expansions document a most generous rubato. Here the notation of durations was understood only as a mere reference for proportions. The same can be said of part V.

In Darmstadt, where the first performance of the complete piece was given, the flute part was performed by Gazzelloni with a much higher degree of freedom. The performance of sections II and IV in Naples can be considered to be more accurate with respect to the notation, so that even if there is no strict metric structure, it is still quite precise in terms of pitch, articulation and dynamics. In Darmstadt there are more pronounced reductions of durations, faster, almost «rushing» tempi and clear deviations from the text, particularly in those sections. This reading could have been motivated by the search for different approaches to the idea of open form.

The last part, however, even if it contains additional –maybe improvised– material, combines elements of sections V and III in a way that comes closer to the respective remarks in the score than the other performances.

The Köln performance was again more precise with respect to the published score, although a similar degree of freedom in the time domain as found in Naples can be noticed here, too. Similarly, single elements of the flute fragments in parts III and V have been omitted or repeated. For instance, the third line of part III was repeated once. The first time, the c^1 was played nine times with different appoggiaturas instead of the five notated in the score. The second time, the written sequence was played as written, but the last motive (32nd quintuplet) was omitted. Apart from minor details, an omission in part II (second page, end of second line) and an alien phrase in part IV (fourth system after $c\#^3$) were found. Other than in section V not all fragments were used in section III. In section V, however, additional, improvised elements were played, but no elements of section III were combined. In this regard it is, again, further removed from the indications in the score than the performance in Darmstadt.

Those improvised elements deserve some reflection. Was it an explicit indication by Maderna? Was it motivated by the specific musical situation in order to achieve a certain transition or an appropriate conclusion? In Darmstadt the latter seems to be the case, at least as far as the final phrase is concerned: Gazzelloni starts with the last line of V and adds an appoggiatura (b^2) leading to a sustained fortissimo final note (b^3), clearly intending a strong, almost heroic conclusion in the highest register. In any case, the possibility to react at the moment was an important aspect that might also be considered today.

Naples is by far the longest performance (10'40'') even without the first part, followed by Köln (10'03) and Darmstadt (9'04''). Except for Darmstadt there are also differences in tuning compared to the published score, assuming $a^1 = 440$ Hz and taking as reference the beginning of section II ($d^2 = 587$ Hz): RAI and Köln are approximately 1/8 tone lower, Naples is even 1/4 tone lower. That means that the recording fragment of Köln included in RAI is consistent, but the II part played live will be heard 1/8 tone higher than the recorded one. Differences in tuning between flute and tape become tricky if the solo part coincides with flute elements in the tape, putting them in evidence. Some performers would like to avoid giving the impression of poor intonation and may try to adapt it locally to the tape.

If we go back to the explanatory notes in the score we realise that the first one, concerning the beginning of the piece, corresponds to the solutions in both Darmstadt and Köln, but the second remark only partially meets the situation because in all three recordings the tape re-enters during section II. This remark can be understood as an invitation to leave the flute a soloistic space in this section and perhaps in section IV as well, according to the original concept, but without necessarily keeping it during the whole section. The remarks concerning sections III and V are consistent

both with Naples (except for the immediate repetitions) and Darmstadt, each one in a different way, although in all three performances additional, perhaps improvised elements were added, single fragments were further deconstructed and rearranged and variations in phrasing and tempo occurred at repetitions.

The variety of relations between tape and flute parts observed in the recordings can help to understand what the third remark means. This and the last one correspond fully to the diversity of possibilities explored by Maderna and Gazzelloni and seem to address the core of the piece. With regard to the tape, they are fully consistent with all three performances in spite of the technical limitations. Preparing a different tape configuration for each performance was much more difficult at the time than it is today. This is remarkable, knowing that several performers today, having all technical possibilities at their disposal, play the whole sequence of tape fragments as delivered by the publisher, without a single change! The fragmentary structure of the tape, the arbitrary length of the pauses and the differences in texture make it hard to believe that it should be considered as an organic, linear sequence that *has* to be played one to one as it is. It rather suggests a collection of materials to be recontextualised in each performance following the spirit of Maderna's last remark and in line with his own practice. Even if the original sequence is maintained, the possibility of deciding the start point of each tape fragment within a given musical context, at a certain point, according to a certain phrasing or in response to a certain gesture or breath of the flute, increases the degree of intimacy in the musical interaction decisively. If the tape is just played as it is, the exploration of the piece's potential as an open work is limited and reduced to the reinvention potential of the flute part. This definitely raises the question of the tape's performance practice today, especially if the re-«invention» should happen in immediate dialogue with the flutist. Insight into the historic recordings may encourage tape performers to regain the openness envisioned and exemplarily practiced by Maderna himself despite the technical limitations of his time, by using tools that enable an immediate access to and use of different sets of tape materials and therefore a dialogue on equal footing between the flute and the tape performer.

Performing *Musica su due dimensioni*

The performances of the piece realised within two projects related to performance practice of electroacoustic music at the ZHdK in two different venues and with two different performers²⁹ were developed along these conceptual lines. A

29 27 March 2013, Zurich University of the Arts, Vortragsaal, Klaase Nieuwhof, flute and 5 June 2015, Toni Areal, Konzertsaal 1, Rafał Zolkos, flute.

playing system based on a Max patch was prepared. The tape fragments were set as individual files and configured in a way permitting the tape performer to access any one in any order immediately and to overlap a maximum of three. A slightly different segmentation of fragments than the one defined for this text was used in the concerts (D-F and I-L were grouped differently). The last version of the interface used to play the tape fragments in the recording is shown in Figure 2. It contains up to three sound file player modules that show the remaining time of the fragment or fragments being currently played. It can be accessed by directly clicking the single fragment-fields or by playing them according to a «score»-list with pre-defined cues containing the fragment label and an optional dynamic correction in dB.



Figure 2: Playing interface allowing direct access to the fragments A–P or a «score» list based control. The «score» list shows the sequence used for the recording (see below) and the corresponding dynamic adjustments (in dB).

The selection and order of tape materials for a given venue was worked out during rehearsals based on, but not strictly following, the order in RAI and was only partially fixed for the concert, leaving a certain degree of interaction possibilities in parts III and V. Solo passages for the flute were left in sections II and IV. Sections

III and V were left open. Only the transition to section IV was previously defined. The final situation at the end of section V was left open as well. Accordingly, the implicit formal layout of the piece, increasingly evolving from a predefined situation at the beginning towards an open situation at the end, was accentuated and the moment of «invention» partially shifted to the concert situation itself, reflecting the improvisation gesture found in the recordings but without using alien materials.

For the loudspeaker setup in concert at least two time-aligned stereo pairs were used: one behind the performer and a second one wider and closer to the audience. By the combination of the three left side-headed fragments, D, B and C in the first performance, fragment D was channel inverted in order to allow for a more balanced sound image. The dynamic level of single fragments was adjusted and the sound carefully equalised according to the system and the acoustic response of the room. In both halls the flute was slightly amplified in order to obtain a better blend of both «dimensions».

Recording

In the recording produced on 7 April 2016,³⁰ however, the number, order and the start points of the tape fragments as well as the start points of the flute parts were defined and rehearsed in advance. Only the repetitions of the flute fragments in III and V were played differently in each take. Still, the length of pauses between fragments and the *exact* start of the single fragments was played in interaction with the flute because solo and tape part were recorded simultaneously in the same room. Figure 3 shows the formal disposition at the recorded version.

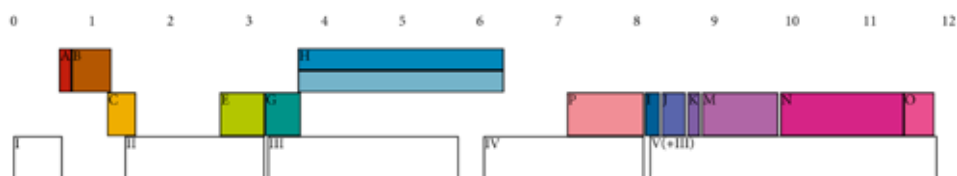

Figure 3: Formal disposition of the recording.

30 Zurich University of the arts, recording studio A. Rafał Zolkos, flute, Germán Toro Pérez, tape, Leandro Gianini and Florian Bogner, sound engineers, Carlos Hidalgo, musical assistance. Released in *Les espaces électroacoustiques. Masterpieces in surround*, Wien, Col legno, 2016 (WWE 2SACD 40002).

The first entrance of the tape is inspired by the performance in Köln where the tape starts in the last flute figure of section I. On the other hand, the use of tape material was analogous to the performance (or broadcast) in Naples: fragment B follows A without pause and B and C overlap about three seconds, allowing the flute to continue alone, beginning with the c^1 (*pp*) in the second line of section II. This leads to a long sequence of the solo flute, considering that the time proportions were more consciously observed as in the historical recordings, but still keeping a sufficiently high degree of freedom. The calm and gentle start of fragment E was chosen to enter in the breath at the end of the third line of the second page of section II, allowing the flute to end together with it. The opening gesture of fragment G was played *attacca* after the II section and the fragment overlapped three seconds with the beginning of fragment H. The flute reacted immediately to fragment G. That led to a relatively long third part, as H was played in its entirety (2'39"). About 30 seconds before its end the flute found a way to finish section III and re-entered with section IV approximately 14 seconds before the end of the fragment, remaining solo for about three systems beginning with the $b\flat^3$ in the first line. Fragment P, closely related to fragments B, C and H, was started in the last rest of the fifth line of section IV and ended together with it. The strong and noisy fragment I was again played *attacca* after the end of section IV and in the following sequence the start points of fragments J, K, M and N were decided in the specific situation according to the phrasing of the flute. The start of fragment O served as a cue to prepare the end, which again was played differently in each take.

All in all, solo passages were once more left in sections II and IV, thus resonating with the very first concept of the piece. The order of the fragments in RAI was basically maintained and their choice was inspired by Naples with some important differences: fragment P was inserted between H and I at the end of part IV and played entirely; L was omitted and O was included at the end, allowing for a long interaction between flute and tape in part V (approximately 4'). Corrections in tuning were done locally by the flutist if predictable: due to the heterogeneity, openness and reiterative structure of the tape it is difficult for the flute player to memorise the tape perfectly, especially when taking into account that it can be differently combined with the flute part. Again, the sound was equalised according to the loudspeakers and the room, the dynamic level of each fragment was carefully pre-set and dynamically changed during the recording in response to the dynamics of the flute. No reverb was added to the tape. In order to avoid comb filter effects, only two loudspeakers were used for recording. The 5.1 mix was done at the postproduction stage, trying to suggest the sense of a surrounding space in a real auditorium

Conclusion

Musica su due dimensioni seems a perfect example for the problematic of electroacoustic performance practice today. Envisioning very early a deep interaction between two musical dimensions the piece implies, by definition, an approach to sound diffusion that may lead to different solutions in different performances. Its early history shows a developing process, a true work in progress, perhaps only apparently finished by an edition and definitely truncated by the early death of the composer. Given the dynamic approach to electroacoustic composition fundamentally adopted by Maderna and documented in a cultivated reworking and recycling of materials based on the immediate contact with the real sound, it is difficult to believe that he would have stopped renewing his own approach to the piece throughout the years, an approach that would necessarily have led to the integration of new technical means.

Maderna's electroacoustic composition practice demonstrates once more that so-called fixed media are only seemingly fixed. Being even more dependent on perception they never meet the same conditions and responses. Musical form finally depends on listening, and even more so if it is conceived as being open, as a field of possibilities.

As performers we may stare in the face of an auctorially fixed document such as a tape. But well-intended reverence does not necessary help to get closer to the spirit of the piece. Trying to understand Maderna's early performance practice may help us to regain confidence and give back to the piece its original multiplicity by allowing for us to interact with the sounding material in a more intimate way.

ALVISE VIDOLIN

Sound direction of 1950s and 1960s tape pieces from the Studio di Fonologia¹

Preface

The electronic music produced at RAI's Studio di Fonologia in the 1950s and 1960s is distinguished from traditional musical production in that it was composed and realised by one and the same composer at the studio, working directly on the sound in a laboratory equipped for synthesis and sound processing. The result was not a score, but the finished work: the music in its final acoustic form, preserved on tape.

With the birth of electronic music, the association between composer and performer, which had characterised the development of occidental music and had produced the enormous variety of masterworks that are part of our history, has been broken. Similarly, the means of musical production and listening have changed radically: electronic music is listened to by means of a machine reproducing the magnetic tape, which is connected to an electroacoustic sound diffusion system, and we call music listened to in this way acousmatic music. In live performances of electronic music, the functions traditionally carried out by the performer have in part already been realised by the composer creating and editing sounds and are in part realised by the electroacoustic reproduction and diffusion system that transforms the content of the magnetic tape into the sensory acoustic form. This last aspect was initially considered a purely technical matter due to the radiophonic nature of the first musical productions, but beginning in the 1960s, when electronic music was gradually being presented more frequently in concert programs, quality and modality of listening became important factors in valorising the musical content of the work.

It was in those years that the figure of the sound director was born, the craftsman providing the correct playback of the recorded music, his main tasks being to choose the electroacoustic system and the arrangement of speakers in the space and to realise the dynamic control and possibly sound spatialisation in concert.

1 The term «sound direction» is used here to highlight a musical, interpretative role in contrast to a merely technical role as implied by the term «sound engineer».

Often it was the composer himself who took on this role, but over the years and with the growth of the acousmatic musical repertoire, specific professionalism and technologies developed.

Concert performance of tape music

Playing the Fonologia tapes of the 1950s and 1960s today presents the sound director with a series of technical, aesthetic, interpretative and philological questions, rendering his work complex and fascinating at the same time. As a consequence of the continued technological development and the rapid obsolescence of the apparatuses used in those years, it is impossible to use the original technical setups for reproducing and listening to these musical works. On the other hand, if we had this possibility, we would most likely be disappointed, accustomed as we are to listening to music played on sound systems of better quality, having more power than those of that time

Therefore, one of the first choices the sound director must now make when preparing for an acousmatic concert regards the following alternative: to simulate what is assumed to be the listening situation of the time, or to provide the best possible listening experience of the sound document that was recorded on magnetic tape by the composer, without, however, altering the content. We must not forget that in those years, listening to recorded music at a concert was, for a large part of the public, an abnormal event, whereas today, young generations are accustomed to listening acousmatically, as listening through headphones or speakers nowadays is much more common than listening to live performances. It is also very difficult to find the ideal listening solution for each work, as the attention of the composers in this historical phase of electronic music was mainly devoted to compositional aspects, while listening situations could vary greatly depending on the space and the available equipment. It was still too early to establish a performance practice or to set down instructions on diffusing a work in some kind of a score. In those years, the sound direction was predominantly carried out by the author himself or by a technician who was working at the author's side and following his verbal instructions; the few existing documents are notes for personal use and not «scores» with prescriptive directions on the specific sound direction for a work.²

2 A first example is the sound direction notebook made by Nono for *La fabbrica illuminata*, which has never been published and is available at the Fondazione Archivio Luigi Nono. See Figure 2.

The decision to offer the public a listening experience corresponding more closely to contemporary quality standards and to put greater emphasis on the musical elements present in the work to be played is therefore practically obligatory, imposed by the lack of precise information on which to base a purely philological interpretation of the sound direction.

It is important to remember that until the 1980s, that is, until the advent of digital formats, it was common to receive rental tapes from the publisher for concert performance missing a great deal of information, whether musical, such as the dynamics of the performance, or technical, concerning the tape, the winding direction of the reel (head or tail out), or the number of tracks (mono or stereo), etc.

Frequently, hire tapes were second- or even third-generation copies of the master tape and in many cases written information, markers and any separators present in the master tape were lost, because such information was rarely given on the copy, thus depriving the director of fundamental information for the correct performance of a work. The absence of information on the dynamics of the tape performance leads the sound director to subjective choices that can have a significant impact on listening and to some extent also on the overall aesthetic of the work, especially if there isn't even a test tone at 0 dB on the tape, which, along with the tape background noise, is a useful reference to determine the extreme sound levels.

In this context, with written and/or oral prescriptive elements often missing, it is useful for the sound director to equip himself with a tool to help with the execution of the tape, preparing a sound direction script, making personal choices or taking into account suggestions from listening scores developed in the analytical-musicological field.³

The electroacoustic sound diffusion system

The first electronic musical works coming out of the Studio di Fonologia were intended for the radio, in those years transmitting in mono, and the tapes of Berio's *Mutazioni* (1954–6) and Maderna's *Sequenze e strutture* (1954) and *Notturmo* (1955–6) were in fact recorded on a single track.

In the score of *Musica su due dimensioni* (1958), Maderna writes «per flauto e registrazione stereofonica» (for flute and stereophonic recording), which reveals an interest in the spatial listening dimension that had begun a year earlier with *Syntaxis* (1957) and for Berio with *Perspectives* (1957), both works with

3 François Delalande, «En l'absence de partition: Le cas singulier de l'analyse de la musique électroacoustique», in *Analyse Musicale*, 3 (1986), pp. 54–58.

two tracks, as were the two successive electroacoustic works, *Continuo* (1958) and *Thema (Omaggio a Joyce)* (1958). In 1959 the studio was equipped with two four-track recorders, which initially were mainly used for tape *montage* of musical segments and then for realising compositions intended for a quadrasonic sound space. With these recorders, Berio realised *Momenti* (1960) and *Visage* (1961), but the four-track version of this last work was described as «NON BUONA» (NOT GOOD) by the author himself in a specific annotation on the box containing the explicit direction to use only the two-track version.⁴

Nono's first electronic work *Omaggio a Emilio Vedova* from 1960 was mounted on four channels, but in this case the use of the quadrasonic format does not seem to point to a specific spatial project. In those years it was probably also hard to transport a four-track recorder to a concert hall, the machine having been designed and wired for work in the studio and being of considerable size and weight. In addition, period photos don't even show a quadrasonic listening setup in the studio, which would have been required for four-channel space experiments. This was realised in 1968, as can be seen in the photos of the renovated studio and confirmed by an internal document of the RAI showing even a five-speaker setup with three front and two rear speakers. One would have to wait until 1964 to hear a composition that was specifically conceived to be listened to quadrasonically: *La fabbrica illuminata*, a work by Nono for voice and magnetic tape in which the space is composed with great mastery and is already fixed by the composer on the quadrasonic concert tape: the placement of choirs, movements of masses of sound, the reverberant field, the spatialisations.

In the sound direction notebook mentioned above, the author's indications concern mainly the dynamics, which underscores the leading role played by the sound director in realising the dynamics contained in the tape at pianissimo and fortissimo levels according to the requirements of the space to achieve an effective musical result.

Figure 1 shows a schematic of the electroacoustic system set up by the RAI technicians for the performance of *La fabbrica illuminata* and *Ricorda cosa ti hanno fatto in Auschwitz* (1966). It is interesting to note that the power of the amplifiers is 50 W, which today would be considered insufficient for amplification in concert halls, and that testimonies from the time say that the sound had been extremely loud, even close to the threshold of pain. We do not know in detail about the efficiency of the speakers used but it is very likely that the sensation of loud sound was caused primarily by violent sounds engulfing the concert hall, such as the noise of pouring iron at the *Italsider* foundry of Genoa-Cornigliano, or by possible distortions caused by the system being pushed to its limits, rather than by really high levels of sound pressure.

4 Maria Maddalena Novati, Catalogo, in *Lo Studio di fonologia. Un diario musicale 1954–1983*, ed. Maria Maddalena Novati, Milano, Ricordi – Universal MGB Publications, 2009, p. 127.

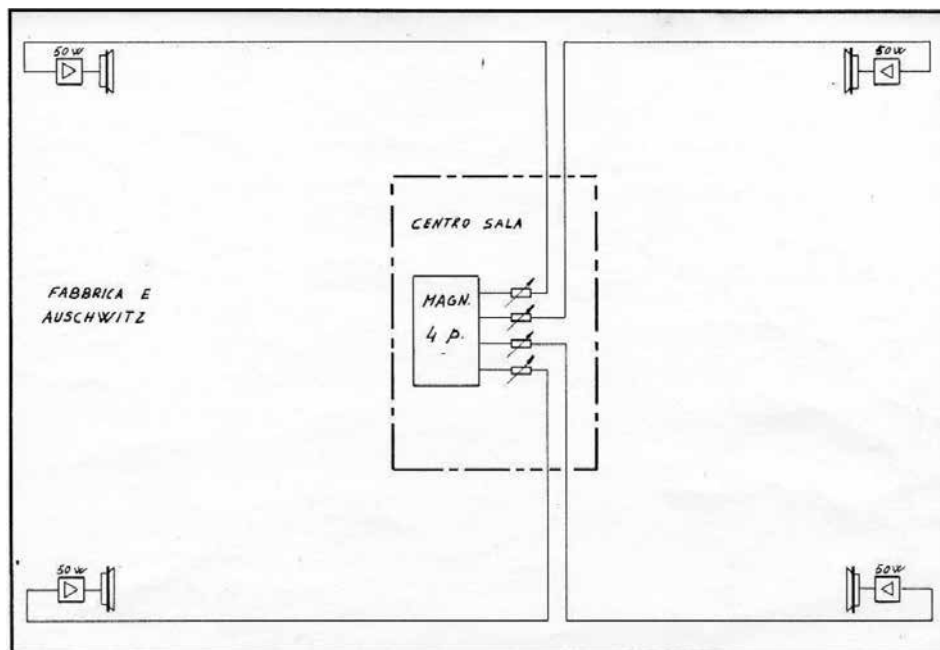

Figure 1: Schematic of the electroacoustic system used for the performance of *La fabbrica illuminata* and *Ricorda cosa ti hanno fatto in Auschwitz* (1966). Archive of the Studio di Fonologia, Milano.

As far as the space is concerned, it is impossible to generalise for all compositions. In this regard, it is significant to make a comparison between the two works in the diagram in Figure 1: the designated concert master tape and the electroacoustic diffusion system is quadraphonic for both pieces. Analysing the quadraphonic tape, however, it will be noted that in *La fabbrica illuminata*, the movements of sound in space, along with its relative reverberations, are already fixed in the recording and therefore the sound director must limit himself to the dynamic control of the tape as indicated in the author's sound direction notebook (Figure 2).

In contrast, in *Ricorda cosa ti hanno fatto in Auschwitz* the four tracks contain the same monaural signal, as dynamic articulation and spatialisation of the sound was done quadraphonically in concert by the composer,⁵ working manually with the four output-level control potentiometers. In successive works, Nono experiments with other solutions for the articulation of musical space in concert,

5 In the 1980s Nono performed *Ricorda cosa ti hanno fatto in Auschwitz* using, on several occasions, the electroacoustic multichannel system of the Freiburg Experimentalstudio. In these performances, sound spatialisation was realised using a number of speakers (always exceeding four), depending on the audio system available in the hall for the performance of other live electronic pieces.

an example of which is the electroacoustic system envisioned for *A floresta é jovem e cheia de vida* (1966) for soprano, three actors' voices, clarinet in b-flat, metal plates and two four-track tapes (see Figure 3).

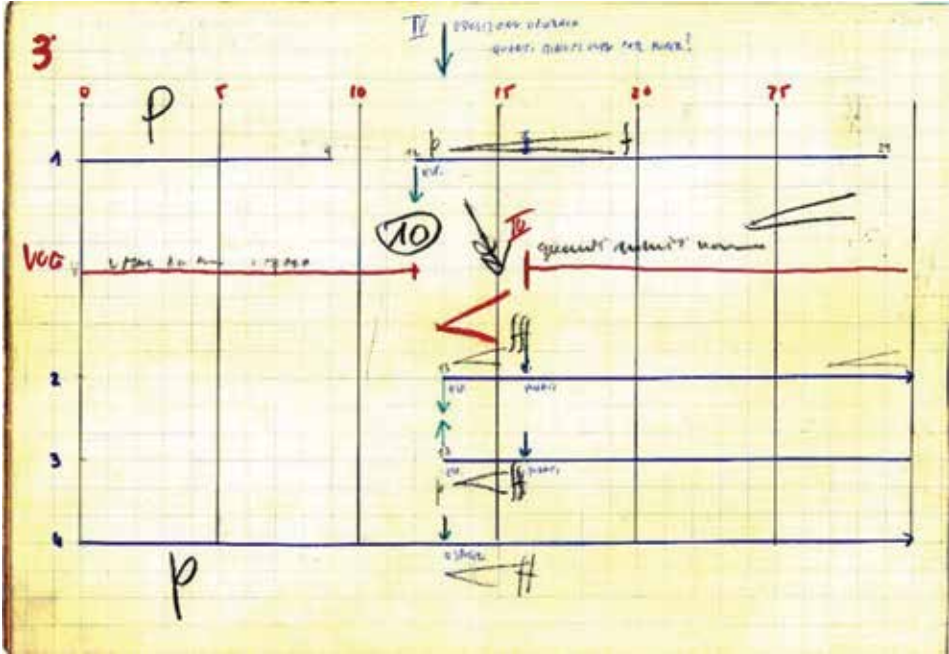

Figure 2: A page from the sound direction notebook for *La fabbrica illuminata*. From 3'00" to 3'30". Author's manuscript. Archivio Luigi Nono, reproduced with kind permission. © Heirs of Luigi Nono.

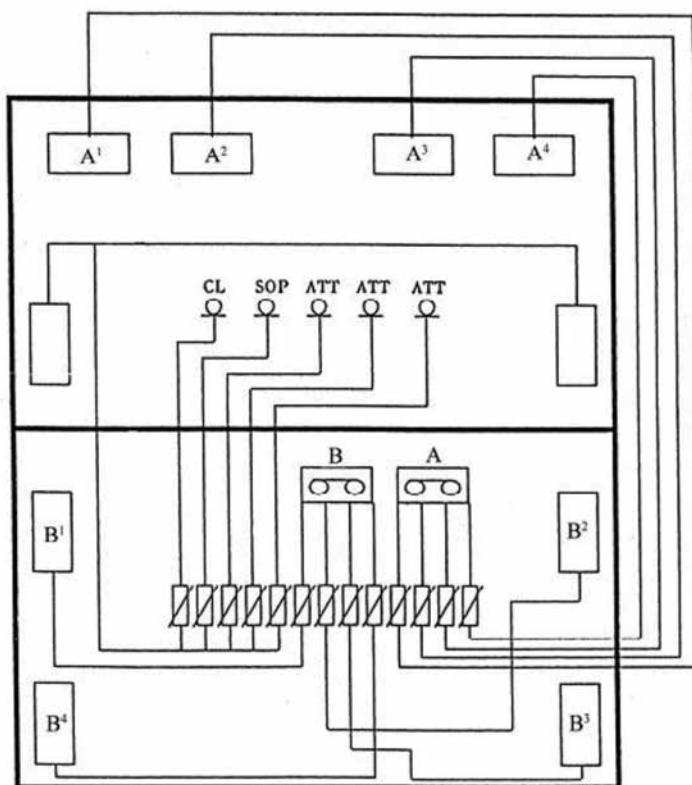

Figure 3: Schematic diagram showing the technical equipment for the live performance of Nono's *A floresta é jovem e cheia de vida* (1966). Score, p. XXVII. Ricordi, 1998. Reproduced with kind permission of HAL LEONARD MGB S.R.L., Italy.

From analogue to digital

The transition from analogue to digital audio technology prompted publishers and music archives to transfer magnetic tapes to new media in order to avoid the permanent loss of important musical works, imminent because of the natural degradation of the magnetisation of the tape, the obsolescence of playback devices and the loss of skills related to their use, maintenance and repair. The realisation of these transfers also presented an opportunity to identify the original masters and to collect as much documentary data on the individual works as possible.

The Studio di Fonologia has undertaken several digitisation efforts since the early 1990s, first onto DAT, limited to monophonic and stereophonic tapes, and later on DTRS to include multi-track works. The last effort, begun in 2005, led to definitive digital archive copies of the works produced at the studio (Novati, 2012).⁶ This was done in collaboration with the University of Udine, involving extensive research on the re-mediation of sound documents,⁷ as a result of which a specific protocol for the creation of a conservation copy that can replace the original in all respects was developed. Under this protocol, the conservation copy includes one or more audio files depending on the number of tracks on the original tape in BWF 24 bits, 96 kHz, along with a video recording of the running tape to minimise the loss of extra information contained on the analogue support (graphic signs, cuts and splices on the tape, possible corruption). To this is added the contextual information present in the original document (photos of envelopes, cases, boxes, labels, reel, the support, attachments, etc.), and the metadata obtained from the transfer process with complete technical information.

The conservation copy's purpose is thus to keep intact the documentary unity of the work also after the re-mediation process with its transfer from analogue to digital. In order to keep such a copy unaltered in its final digital form, the protocol also provides control tools ensuring the integrity and completeness of the data over time or in case transfers are made. Such a copy, kept intact in the archive, will only be used to create additional specific copies for different purposes. For concert performances, restoration operations are frequently applied, above all to reduce artifacts produced by unintentional alterations (e.g. defects of the devices), intentional alterations (e.g. specific equalisation procedures), to reduce the background noise of the tape, but also to improve the sound quality of the document. Such operations must be carried out with great care and skill considering that, especially in the field of electronic music, the line between sound and noise is a very thin one, and an inexperienced restorer could alter or even remove important sound bits from the work. In other words, the restoration work involving a piece of electronic music work can be considered part of the interpretation process carried out by the sound director, therefore, his aesthetic choices begin at the restoration of the tape used for acousmatic reproduction.

In this context, I think it is useful to give a short testimony about the restoration work that was done on Luciano Berio's *Thema (Omaggio a Joyce)* in the 1990s at the Centro Tempo Reale in Florence in the presence of the composer.

6 Maria Maddalena Novati, «The Archive of the Studio di Fonologia Musicale di Milano della Rai», in: Maria Maddalena Novati and J. Dack (eds), *The Studio di fonologia. A Musical Journey 1954–1983. Updated 2008–2012*, Milano, Ricordi, 2012, pp. 143–146.

7 Sergio Canazza and Mauro Casadei Turrone Monti (eds), *Ri-mediazione dei documenti sonori*, Udine, Forum, 2006.

This restoration was intended for publication on the album *Many More Voices* (RCA, 1998). After the de-noising operation, which had considerably reduced the background tape noise, Berio wanted to shorten all the pauses on the fixed media as he hated the silence that had indirectly been created. In this case, the composer intervened in his own work, but would such an action be considered just as legitimate if it were taken by the restorer alone? Most likely not; the restorer would leave the pauses unaltered, thus affecting the overall balance of the work.

Techniques of sound direction

The transition from analogue to digital technology doesn't just concern the re-mediation of magnetic tapes into numerical audio files, but also affects the greater part of the electroacoustic system. Digital devices are increasingly replacing analogue technology, which is increasingly limited to amplifiers and signal transducers such as microphones and speakers. The diffusion system, too, has evolved considerably over the years, taking into account various typologies of speakers with different characteristics depending on the type of use and the musical genre. Today, there are very powerful, directional sound sources able to deliver excellent results even in outdoor concerts or in large spaces, as well as in closed environments where a high level of reverberation would make listening to music difficult if it were amplified with traditional speakers.

In the area of sound spatialisation as well, manual techniques as practised by Berio, Maderna and Nono since the 1960s⁸ can be realised using computerised systems controlled by the sound director, offering a great variety of musical solutions.

In this area, a paradigm shift occurred with the transition from the use of one speaker, originally intended as a substitute for a performer or a small group of performers, to the use of a set of speakers configured as a system capable of simulating not only individual points, but also lines or sound surfaces, defined according to the possibilities offered by the system as a whole. Several theories exist on determining the design and complexity of such systems, obviously leading to very different results in terms of quality. A discriminating factor is the space in which the concert is to be performed. If it is a traditional auditorium or an Italian-style theatre, there are great limitations imposed on the system. Rarely is a multi-channel amplification system already installed in such a space, and the layout and installation must be set

8 Including the so-called technique of «fare la pasta» (pasta making), as Berio described the movement of the hands operating the individual level controls, similar to that of hands working the dough.

up from scratch each time, determined largely by the acoustics of the space and by architectural and security constraints regarding the position of the sound director and the speakers. The case of a new auditorium, designed for acousmatic music concerts with variable acoustics and a stable system of sound diffusion and spatialisation, is completely different.⁹ In everyday musical life, the opportunity to use fully equipped spaces of this type comes up rarely; traditional concert halls with the constraints listed above are the rule.

Performance environments

Before going into the technical details, it may be useful to highlight some tools with which the sound director attempts to realise the best possible listening experience and the expressive rendering of the musical repertoire in question. In order to achieve the desired musical results, the sound director must set up the ideal performance environment for each piece, meaning a set of hardware and software tools resulting in a musical instrument for live performance.¹⁰ We shall give some examples.

As we have already seen, the control of dynamics, which in the 60s was achieved by simply changing the level of amplification, is of primary importance in the performance of the tapes. But, as an example, let us consider what one perceives when raising or lowering the volume of a home amplifier while listening to an orchestra piece: one doesn't hear the orchestra play more softly or loudly but rather perceives it to be closer or further away. In other words, if the orchestra is playing fortissimo *fff*, lowering the volume of the amplifier does not give the sensation of the orchestra playing pianissimo *ppp*. So in psychoacoustic terms, the dynamics control is more of a timbre than an amplitude control. In fact, a loud sound is complex, brilliant, sometimes aggressive, with a rich spectrum of harmonics and sometimes containing even inharmonics and noise.

9 The best results in terms of spatialisation are obtained in anechoic environments where it is possible to install systems such as Ambisonic or wave-field synthesis including the simulation of the desired (virtual) sound environment. These solutions are very interesting for acousmatic music, but they become difficult to manage in repertoire for voices/instruments and fixed media because live performers are used to relying on good acoustic feedback, which cannot be given by an anechoic environment, and is also difficult to create artificially without interfering with the spatial processes of the acousmatic part.

10 See Alvise Vidolin, «Musical interpretation and signal processing», in: Curtis Roads, Stephen Travis Pope, Aldo Piccialli and Giovanni De Poli (eds), *Musical Signal Processing*, Lisse, Swets & Zeitlinger, 1997, pp. 439–459.

Conversely, a soft sound is exactly the opposite; sweet, agreeable, with dark timbre, its spectrum containing few harmonics and almost sinusoidal, meaning any noises tend to be heard separately from the main sound. Moreover, in the orchestra soft sounds are very different from instrument to instrument, due to the different types of sound generation (the breath for the flute, the bow stroke for the violin, the mechanics of the hammer for the piano, etc.). To control the tape dynamics effectively, it may therefore be necessary to correlate the amplitude control with a filter progressively opening in the area around 3000 Hz with increasing dynamic levels and, accordingly, progressively closing, attenuating frequencies above 2000 Hz for lower dynamics. The adjustment of the filter depends on many factors: the music to be played, the sound of which could already be dark or bright, or could have become dark due to the analogue tape having aged before having been digitised, on the electroacoustic system, consisting of speakers that might sound more or less brilliant and aggressive, and on the acoustics of the space that may not always give a linear response to changes in frequency and dynamics. In conclusion, the sound director can create a performance environment in which it is possible to articulate the performance dynamics of a fixed medium more effectively than by simply changing the level of amplification. Such an environment must be «fine-tuned» each time based on the musical work to be played, the space and the electroacoustic system installed, carefully determining the limits of these timbral changes in order to keep the actions of the sound direction within the boundaries of expressive variation.

In addition to controlling the dynamics, the sound director is responsible for sound projection and, where required, spatialisation. Again, these solutions and interpretative choices may depend on various factors; above all, on the music: there are works in which space is a compositional parameter and others that do not work on that level and therefore require only a good diffusion of the fixed media depending on the number of tracks. In works belonging to the first category, however, the space can either be stored completely on the fixed medium's multi-tracks, or it can be left to the sound director's interpretative discretion, as the comparison of the quadrasonic tapes of Nono's *La fabbrica illuminata* and *Ricorda cosa ti hanno fatto in Auschwitz* showed. In general, the diffusion of sound can be static or dynamic. A static diffusion can be pointlike (coming from a specific point) or distributed (immersive listening, immersion in the sound). Dynamic diffusion provides various types of movement: here, too, we can have point-like movements, such as jumping from one point to another, or continuous movements gently flowing along a trajectory.

In analogy to traditional performance practice, we could distinguish between these movements by referring to them as «staccato» and «legato». The movement may be fixed or random with respect to both trajectory and speed. The speed, in particular, due to phenomena of compression and expansion of the acoustic

waves that are created in moving sound sources, produces sound frequency alterations according to the law of physics known as the Doppler effect.

Depending on the choice of motion simulation model, the Doppler effect can be made perceptible or not, depending on the type of sounds that need to be spatialised or also to avoid «wrong notes» in the musical parts.

From a technical point of view, there are several theories, practices and electroacoustic systems able to meet the musical requirements described above at varying levels of quality. The choice depends on various factors, some of which have to some extent already been discussed above, others being too complex to discuss exhaustively here. So I will just consider the most common concert situations with the musical repertoire discussed here, realised in traditional halls, with technical equipment chosen, transported and installed for the occasion, the rental fee lying within a budget similar to the concert fee of a performer and with the usual constraints imposed when using a space for one single day. Let us assume a hall holding 400–500 persons with a system of nine speakers and two subwoofers set up as shown in Figure 4.

Contrary to the logic guiding the events of the entertainment world, where a concert in a small space packed with people appears to be more successful than the same event with the audience distributed in a larger space, it is preferable in acousmatic concerts to have a space of higher capacity than the actual number of listeners present in order to allow for the audience to be seated in the central area of the space, which offers the best listening experience.

In fact, a listening position at the side, very close to one of the speakers, suffers from a deformed sound perspective. In order to prevent critical situations of this type, it is always preferable to have the speakers placed as far away as possible from the chairs, if necessary raising the speaker position vertically, if there is not enough physical space in the side corridors. When performing in multi-storey halls, for example with stalls and galleries, or Italian-style theatres, the task becomes complicated because it is necessary to duplicate the speakers on the various levels or to limit seating to one area with suitable acoustic conditions.

Let us now suppose that we operate with the electroacoustic system shown in Figure 4 and see how it is possible to realise what has previously been hypothesised. Then we will look at some specific sound direction examples taken from our repertoire. The characteristics of static diffusion of the pointlike type depend on the technical characteristics of the speakers making up the electroacoustic system. Such speakers, depending on the manufacturer's choices, can have a very narrow or a wider diffusion range in order to cover a more or less wide area with different directionalities. The same music played by these two types of speakers sounds different and therefore such a choice belongs to the process of planning the electroacoustic system. Ideally, one would provide various types of diffusion as is the case with the different instruments of the orchestra.

On the other hand, if we take the orchestra as an example of sound diffusion system, we notice that the trumpet has a direct diffusion, the horn a reflected diffusion, the cello changes the directionality at 360° according to the height of the note played, etc. Each instrument has its own characteristics, which are translated in acoustic terms ranging from point-like diffusion to reflected diffusion.

In the 1970s Francois Bayle conceived the acousmonium, a diffusion system for acousmatic music composed of many speakers, each with different diffusion, localisation and orientation characteristics, in order to artificially recreate the various diffusion characteristics of the orchestra instruments. This system offers good results on a musical level; however, it is more suitable for fixed installations, calibrated to correspond to the acoustic properties of a specific space, as opposed to transportable solutions that are easily adaptable to different listening spaces. A technique that allows to obtain both point-like and reflective diffusion is so-called transparent amplification. This technique, as applied to the diffusion system of Figure 4, allows, for example, the extension of the stereophonic image onto the whole multi-channel system, assigning specific values to each loudspeaker for delay, amplitude attenuation and further attenuation of high frequencies, thus simulating the first reflections of the space and making the environment more sonorous, without losing the original localisation of the sound source. In other words, the sound is amplified in an immersive way without losing the dimension of perspective. This direction can be oriented, as usual, towards the front of the space, but it is also possible to move the listening focus in the opposite direction, as towards the centre of the hall to simulate an extremely immersive sound space.¹¹ In order to achieve better expressive control over the amplification, it is useful to insert an attenuation control/transparency booster, making it possible to alter the physical laws of sound attenuation according to which the decrease of the signal amplitude is inversely proportional to an increase in distance of the sound source. With the help of this control it is possible to make the amplitude of the simulated reflections decay more rapidly, making them present only in the first speakers close to the source or to increase the amplitude in such a way that all the speakers amplify the signal with the same level.

11 The simultaneous diffusion of a monaural track on all speakers is not perceived by the audience as an immersing sound coming from all directions. On the contrary, each listener simply hears the monaural sound coming from the closest speaker.

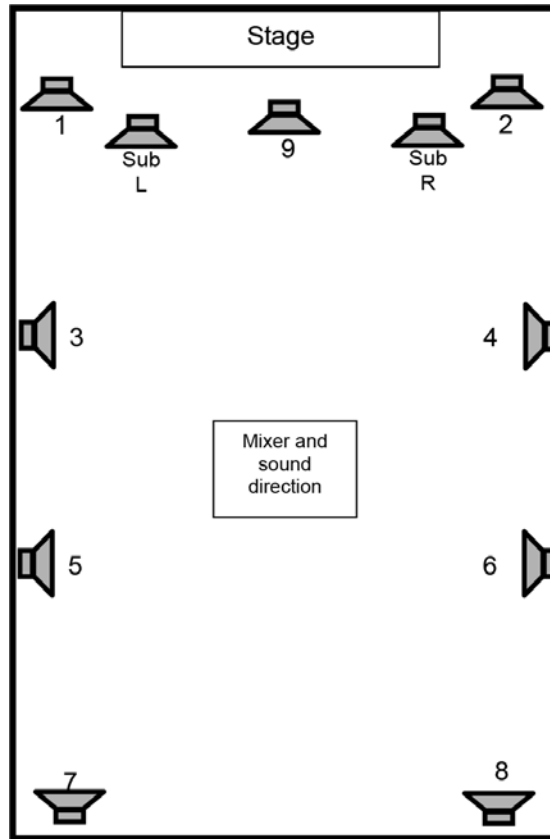

Figure 4: Electroacoustic sound diffusion system for a hall with 400–500 seats.

As for sound spatialisation, the most efficient technique is multi-channel panning, simulating the movement of sound through crossfades between pairs of speakers. This technique, using only amplitude variations to simulate sound movement, can be considered an expansion of the quadraphonic spatialisation realised manually in the 1960s in live performances of many Fonologia tapes. Thanks to computer automation technology, the sound director of today is able to control the movement of the virtual sound sources, moving them at variable speed along the electroacoustic speaker system. The «staccato» movements are obtained through rapid crossfade from one speaker to another, while «legato» movements are realised by using three speakers, instead of two, along the sound trajectory. Furthermore, when using only amplitude variations, the Doppler effect, which is generally unwanted, does not occur. Using the manual techniques of quadraphonic spatialisation, the sound director could only handle two lines of spatialisation, limits that are absolutely surmountable today in the design of electronic music performance environments. When spatialising stereo tracks, the speaker pair can

be moved synchronously, moving the stereo image along the desired trajectory, or asynchronously along independent trajectories, creating the impression of being compressed or expanded along every step of the trajectory, depending on the distance between the speaker pair.

The choice of a system with nine speakers is a good compromise providing a sufficient number of points for «staccato» diffusion with a good variety of localisation. At the same time, the distance between speakers also allows «legato» movements from one speaker to another, ensuring a fluid movement along the sound trajectory. One should remember that, with such a system installed in a concert hall, trajectories that can be simulated are always outside the perimeter outlined by the speakers.¹² It is therefore not possible to bring the sound movements to the central areas of the space, while it is relatively easy to virtually enlarge the physical space, using the nine speakers to create a diffuse and immersing reverberant field. As we have seen in the example shown above regarding the variation of the amplification level of a recorded orchestra, it is possible to produce sound movements of the *far-close* type. This movement is even more strongly perceived in the presence of a slight reverberant field, which increases the virtual size of the listening space.

The perceived distance is determined by the direct/reverberated signal ratio. The closest point of source location is given by the distance between listener and speaker, while the farthest point is established by the extreme limits of the virtual space defined by the reverberant field. Finally, the direction of the sound moving away depends on the location of the direct signal.

Examples of performance environments for sound direction

1. Luciano Berio, *Visage* for electronic sounds and Cathy Berberian's voice on tape

Luciano Berio composed *Visage* in 1961 at the Studio di Fonologia of the RAI, Milan, realising a work with acousmatic music for voice (Cathy Berberian) and electronic sounds on stereo tape. In the words of the author «*Visage* è essenzialmente un programma radiofonico: quasi una colonna sonora per un dramma mai scritto.» (*Visage* is essentially a radiophonic program: a soundtrack for a drama never written.) The fact that it was realised in stereo (at a time when the RAI was broadcasting in mono) confirms Berio's interest in the spatial dimension, which in

12 With wave field synthesis it is even possible to place the virtual sound source within the speaker system, with the constraints mentioned earlier, which cannot be overcome in a traditional concert hall.

those years was emerging as a new compositional parameter not only in the area of electronic music. He did not limit the listening situation to a specific space or to the radio. Again in his own words: «La sua destinazione, dunque, non è solo la sala da concerto ma qualsiasi luogo o mezzo che permetta la riproduzione di suoni registrati.» (Its destination, therefore, is not only the concert hall, but any place or method that allows the reproduction of recorded sound.)

Given these premises, it seemed interesting to me to conceive a version of *Visage* that would enlarge the spatial dimension already delineated in the original tape to create a wider perspective than is offered by stereophony, using multichannel audio systems comprising a central speaker (*cluster*) and a variable number of speakers placed around the audience (*surround*) and selected based on the dimensions and acoustic properties of the hall (4, 6, 8, etc.). This resulted in the proposal of a new listening experience for *Visage*, which we could call acousmatic rendering, the audio materials of which are always and exclusively the original ones but in which the spatial dimension is widened to create a listening situation that is not simply frontal, but one of total acoustic immersion with a clearer and more involving sound perspective. In order to achieve this, I converted the original tape into a three-channel *fixed media* using spectral subtraction technology to create a mono track containing mainly the vocal part and a stereo track containing the electronic sounds.

I will now give an example of the performance environment for a performance of *Visage* with the electroacoustic system shown in Figure 4 providing the following controls.

1. Dynamic control of the track containing the voice, diffused over central speaker 9.
2. LCR panning to move the track containing the voice between speakers 1, 9, 2.
3. Control of the reverb level of the voice track, diffused over speakers 1 to 8.
4. Dynamic control of the voice's spatialisation on an aleatoric trajectory in speakers 1 to 8.
5. Control of the speed of spatialisation with variable transition times between speakers from 0.3 s to 8 s.
6. Control of the transparent amplification (in stereo) level of the electronic sound diffused by speakers 1 to 8.
7. Control of the transparent amplification's attenuation/boosting factor.
8. Dynamic control of the spatialisation of the electronic sounds on two tracks. Two independent lines on an aleatoric trajectory on speakers 1 to 8.
9. Control of the speed of spatialisation with variable transition times between speakers from 0.3 s to 8 s. The control is effected in a way that allows for slightly varying transition times for the two spatialisation lines.

10. Control of the reverb level for the two electronic sound tracks, diffused by speakers 1 to 8.

In live performance, I use the listening score prepared by Florivaldo Menezes Filho,¹³ which divides the composition in four sections plus a coda. In the first A section, the voice is diffused over the central speaker 9, as if Cathy Berberian were physically on stage, adding light ambient reverb. In other words, I want the beginning to correspond to a listening situation of the original tape according to the author's intention to have the voice localised at the centre, as it was realised in stereo, where the voice was put on both tracks. Had we used the original tape, simply amplifying it in stereo, the sensation of the centrally placed voice would have been perceived only by a small part of the audience or people sitting exactly in the centre of the stereo projection. The others would inevitably have perceived the voice as coming from the left or from the right, depending on their seating position.

The A section ends with a crescendo of electronic sounds in which the transparent amplification expands across the hall, emphasising the intention of engulfing and involving the public in this moment of tension at the conclusion of which one hears «parole» (words). The voice in Section B continues to be at the centre, as if individually telling each member of the audience a story, therefore there is no reverb, emphasising the effect of presence. At the same time, I let the electronic sounds expand within a larger space in which the transparent amplification outlines a slight presence in the distance along with slow «legato» movements that make the light, pulsating sounds casually wander from far to near. At 6 minutes, the word «parole» reappears, and from this point a new moment of tension ensues, culminating at the end of section B. In this short sequence, I spatialise the electronic sounds in a whirling and «staccato»-like manner. Section C resumes with Cathy Berberian's weeping, which turns into laughter and then into guttural sounds and repeated «r» sounds that mix themselves with the expanding and multiplying electronic sounds. At this stage both the electronic sounds and voice are spatialised independently with movements at medium speed, «staccato» and plain (without transparent amplification). The states change rapidly and the voice returns to the centre, moves to the right, back to the centre with the word «parole», returning spatialised (at 10'10", approximately) and concluding the C section with the word «parole» uttered for the fourth time, which explodes in a large, highly reverberant space. Everything stops, the voice turns to singing, far away: I increase the reverb level over the one already present on the tape to open it onto the whole space. The electronic sounds punctuate the environment with a few randomly distributed interventions around the public that slowly turn into *tenuto* sounds over which the voice re-emerges, again at the centre and reciting for the last time «parole». The *tenuto* sounds are transformed into a sound band slowly

13 Florivaldo Menezes Filho, *Un essai sur la composition verbale électronique «Visage» de Luciano Berio*, Modena, Mucchi, 1993.

evolving into a polyphonic texture that I gradually spread to the whole space in a dynamic, slow and powerful crescendo obtained through transparent amplification, gradually increasing the emphasis control until it reaches the maximum, keeping it there for a long time. The 5.1 version of *Visage* uses the guiding principles and techniques illustrated to obtain a multi-channel recording in the format most commonly used in commercial recordings, thus resulting in a product that can be listened to even in the home.¹⁴

2. Luigi Nono *La fabbrica illuminata* (1964) for voice and magnetic tape

The tape of *Fabbrica* is quadraphonic and, according to usual practice, the four tracks would simply be connected to speakers 1-2-8-7. Doing it in this way, however, one almost doubles the distance between the speaker pairs 1-2 and 8-7 and 2-8 and 1-7, creating a sort of sound vacuum in the centre of the space. In cases like this, I prefer to avoid this by using the central speakers 3-4-5-6, appropriately delaying the signal of each track so that track 1 is also diffused by speaker 3 (in effect always localised in the position of speaker 1), and similarly to diffuse track 2 also on speaker 4, 3 on 6 and 4 on 5. This configuration is particularly useful for the iron casting section in which the relative noise must be very strong and engulfing. Furthermore, to emphasise the event more strongly, I enlarge the space in the sequence with quiet dynamics that precedes the crescendo, so as to have the noise of the casting start at a distance, and let the dynamic crescendo proceed in parallel with the sound coming closer. The slight reverberation that allows me to expand the space is diffused by all the speakers including the central ones. For this reason, I have delayed the signal coming from the four tracks, and not the single speaker, so that the reverberant field is distributed evenly on all the speakers. This decision also proves advantageous in a short passage where I use spatialisation towards the end of the second section (from 9'25" to 9'45"). Here the movement I create on the eight speakers suddenly shifts the centre of gravity of the space, which has so far been polarised at the top of the hall's quadrangle.

In this step, spatialisation concerns only track 4, which contains the episode called «drills» in the author's sound direction notebook. As far as space is concerned, my interventions are rather modest, because, as I have said, it was composed and realised completely by the composer having stored the result on the quadraphonic tape.

The most important actions of the sound direction, therefore, relate to the dynamic control of the fixed media,¹⁵ the crescendos and diminuendos of which

14 Editor's note: A 5.1 mix of this version was released on the SACD *Les espaces électroacoustiques. Masterpieces in surround*, Wien, Col legno, 2016 (WWE 2SACD 40002).

15 Which I realise with the equalisation variations described above.

are conditioned by the size and acoustics of the space¹⁶ and in some passages also by the power and the interpretative choices of the singer.

The voice must not be amplified in order to highlight the violence the factory worker is confronted with, and it is important to make this denunciation musically explicit through careful control of the tape's dynamic level.

If the performance takes place outdoors or in very large spaces, I think we should support the voice through slight transparent amplification, provided that this amplification does not appear as such, but is perceived as a natural reinforcement of the acoustics of the venue.

As is the practice in concert performances of works for voice/instrument and magnetic tape, the musician has to know the contents of the tape by heart to maintain proper synchronisation between the two parties. In *Fabbrica* there is a particularly difficult passage for the singer at the end of the second chorus, beginning at about 1'50", in which she has to sing/recite the phrase «su otto ore solo due ne intasca l'operaio» (of eight hours, the worker will only be paid two).

At the end of this sentence, the electronics have to explode very loudly with the sounds of the «esposizione operaia» (workers' exposition). It is not easy for the singer to finish her sentence just before the electronics begin, since the last reference point on the tape is ten seconds earlier.

In order to avoid taking unnecessary risks if the singer does not feel sure, I prefer to synchronise the start of the «esposizione operaia» using a fixed media that has been appropriately divided in two parts, prolonging the end of the first part to avoid a sudden silence if the singer has been behind the prescribed time.

3. Luigi Nono sofferte onde serene ... (1977) for piano and magnetic tape

The magnetic tape of this piece is monaural, and, as the composer himself pointed out, of a quality that from the beginning of the montage was considered unsatisfactory due to distortions that had occurred during the recording process, perhaps also because of the wide dynamic range Maurizio Pollini is able to realise on the instrument.

As in other Fonologia works, the compositional work on the tape was begun by selecting the recorded materials and mounting them on a quadraphonic tape. For reasons unknown to me, the montage process was interrupted about half-way through the piece and was quite possibly completed by Nono using one-track recorders, cutting and joining recording clips or short montages. In 1990 the editor Ricordi took steps to re-mediate the mono master tape considered final, thus obtaining a digital copy. On the basis of this and after minimal restorations (de-noising, de-clicking, minimising of the distortion occurring during

16 A large hall requires greater dynamic expansion.

approximately one minute), the editor has released an audio CD, which today is still distributed with the score as fixed media for testing and concert performance.

The performance of *sofferte onde serene* ... requires performers to make a choice: either to consider the tape an extension of the live piano or to consider it a second piano, playing a duo with the first. The score does not offer any explicit indication in this regard, and so both solutions are valid. In support of the first, there are resonances, noises, and extreme gestures on the tape that point in the direction of a single «expanded» piano; on the other hand, the polyphonic notation in the score and a good part of the piano materials on the tape direct the interpreter towards the idea of a piano duo.

A remark by Pollini in a video made by Bettina Ehrhardt¹⁷ points in the second direction, with the pianist arguing that it is «important that the two voices emerge very clearly in order to follow the composer's work: the musical reality of each element». Such a choice obviously affects the sound director's work, both in terms of the choice of the electroacoustic diffusion system and the design of the performance environment.

During my activity as Nono's live electronics assistant in the 1980s I participated in many performances of this piece, experimenting practically in every concert with the different solutions Nono suggested: from the classical solution with two frontal speakers at the sides of the piano, to a single speaker under the piano directed towards the sounding board, to multi-channel solutions practiced above all in concerts involving the Experimentalstudio der Heinrich-Strobel-Stiftung des Südwestfunks. The most curious performance, judged inadvisable by Nono himself, took place in Baden-Baden in 1984, where the tape was spatialised using iterating movements over eight speakers. After Nono's death I had many other opportunities to realise this piece with different pianists and a couple of times with Pollini himself. Independent of the interpretative choices, the main problem the sound director has to address is the correct reproduction of the recorded piano sound. Like the voice in *Fabbrica*, the piano is not amplified, and I think it is a common listening experience that, even under the best record production conditions, the recorded piano sounds different when compared directly to a piano being played live. A main reason for this difference is the propagation of the recorded sound. The real piano is a large box radiating sound in all directions, while the speaker is a kind of trumpet directing the sound along a precise trajectory.

Furthermore, during the recording, this sound-radiating box is usually recorded with a pair of microphones (in the case of*sofferte onde serene* ... even just one, the tape being monaural), thus compressing the huge variety of sound waves emitted from the piano into a single or at most two sources.

In order to simulate an electroacoustic system with a radiant system corresponding to that of the piano, it is necessary to use different speakers, oriented so

17 Bettina Ehrhardt and Wolfgang Schreiber, *A Trail on the Water*, EuroArts Music, 2006 (DVD).

as to favour the panoply of reflections that the instrument produces thanks to its constructional characteristics. Figure 5 shows a personal note from Pollini written on the occasion of a performance of the piece in the Sala Verdi in Milan, where I was in charge of the sound direction. Eight full-range speakers (plus two subwoofers) were used, arranged at various heights and oriented as shown in Figure 5. Four of these speakers, placed on uprights about 2 metres high, were inclined by 30° – 45° and oriented towards the side walls of the space to produce mainly reflected waves.

Two other speakers were placed under the piano, facing the sounding board, and finally, two speakers were placed on either side of the instrument at a height of 1 metre to simulate the wave front coming from the piano with the lid open.

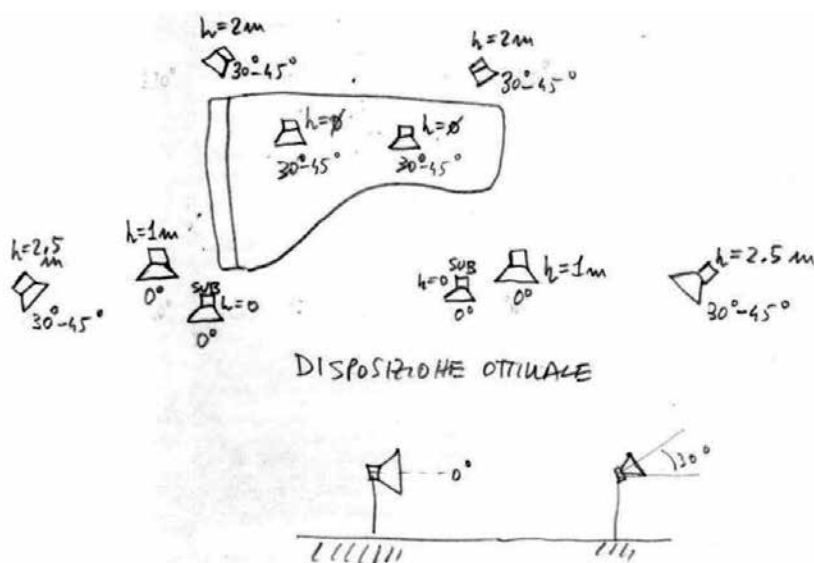

Figure 5: Speaker setup for*sofferte onde serene*... at the Sala Verdi di Milano for a performance by Pollini.

The result was excellent and much appreciated by the large audience that filled the hall with a seating capacity of 2000. Pollini prefers to interact with the tape dynamics himself, rather than delegating this role to the sound director. Accordingly, much time was devoted during rehearsals to the setup and orientation of the speakers and then to fixing the level of the tape performance.

The level can be slightly adjusted in concert, but only to compensate for sound changes due to the presence of the audience.

Performing this piece in a concert alongside other pieces using a traditional setup of speakers placed around the public, such as shown in Figure 4, may lead to difficulties if one attempts to position the speakers as shown in Figure 5. In

practice, one should install a dual system or find a solution providing the same result by other means.

I will now briefly illustrate the performance environment I created for *sofferte onde serene* ... using the electroacoustic system as shown in Figure 4, in which speaker 9 is placed under the piano, oriented towards the sounding board. The performance environment has the following controls for the performance of the tape:

1. Dynamic level of the tape on front stereo, speakers 1 and 2.
2. Dynamic level of the tape on speaker 9 under the piano, 9.
3. Dynamic level of the tape with application of transparent amplification on speakers 3 to 8.
4. Equalisation of the tape: level of low frequencies (+/- 18 dB, low shelf filter with cutoff frequency at 100 Hz, non resonant).
5. Equalisation of the tape: level of high frequencies (+/- 18 dB, high shelf filter with cutoff frequency at 1000 Hz, non resonant).
6. Dynamic level of the tape on subwoofers.
7. Reverb level of the tape on speakers 1 to 8.

With the configuration of Figure 4, the front sound might seem too open compared to the classic arrangement with two speakers at the sides of the piano, also illustrated in Figure 5. The problem can be addressed in two ways.

Adjusting the level of the front stereo to that of the loudspeaker placed under the piano, it is possible to move the image of the front sound towards the centre of the piano. Should this require excessive amplification on speaker 9, disturbing the pianist's performance, speakers 1 and 2 carrying the stereo could be delayed about 10 milliseconds, so as to move them a few meters towards the back of the stage.

The reflected diffusion realised in the setup of Figure 5, with the four speakers facing the side walls of the space, can be simulated by applying transparent amplification to speakers 3 to 8, obtaining an equivalent result.

As we said earlier, it is not easy to obtain a good reproduction of the piano sound over an electroacoustic speaker system. Often, treble speakers (tweeters), which are part of full-range speakers, are directional and very aggressive and can transform the high-pitched sounds of the piano into an excessively bright, metallic timbre.

At the opposite end of the frequency spectrum, the piano tone is lacking in energy in the low register, giving the instrument its characteristic metallic sound. Many speakers, accommodating current listening trends, reinforce the low sounds, thus altering significantly the recorded piano sound.

For these reasons, the performance environment uses two shelf filters for controlling the energy in the high and low registers so as to tonally «tune» the tape to the electroacoustic system used. These controls have been incorporated

into the performance environment because the tape of *sofferte onde serene* ... requires tonal adjustments in performance.

Particularly in section four of the tape from 5'11" to 6'49", there are bumps created by the piano pedal that would be excessively attenuated by the filter if keeping the equalisation set for the previous sections. If necessary, the performance environment also provides control of the tape level on the subwoofers to give more body to these recorded pedal bumps.

Similarly, as if mirrored, high notes played fortissimo appear on the tape at 6'25"; in this section it is often necessary to attenuate further the energy above 1000 Hz in order to balance the timbre and dynamics of the tape with that of the live piano. Finally, the performance environment can control the level of reverberation, which in this piece should be used sparingly and only if the hall's acoustics are too dry.

This performance environment allows the sound director to meet the requirements of the two interpretative choices discussed above. As we have seen, the separate level controls for the front stereo and the centre speaker allow the integration of the tape part and the piano, going in the direction of a hyper-piano; conversely, favouring the diffusion of the tape on the front stereo speakers accentuates the separation between the live and the recorded piano, highlighting the polyphonic aspects of the score. The fact that these controls can be varied in real time enables one to go from one situation to another, even during performance, thus offering greater freedom to the performers.

Conclusions

The concert performance of music for magnetic tape is an interpretive act accomplished by the sound director and is therefore subject to philological and/or subjective choices in order to achieve a diffusion of the recorded music that respects the work's musical conception, follows the composer's performance practice (if known) and is effective for a public now used to listening to acousmatic music in various binaural forms, domestic and public. The sound director is thus responsible for creating a real «mise en espace» of the recorded sounds, choosing the most appropriate space for the music to be diffused in, and designing the electroacoustic system and the performance environment most suitable for the interpretive choices made. Based on the music and the architectural properties of the space, he will determine the number, power and setup of speakers, placing his controls in the centre of the space.

The electroacoustic system has to accommodate the diffusion of works with the number of audio channels intended for this music in the Fonologia repertoire of the 1950s and 1960s ranging from mono to quadraphonic. However, we have seen that tracks conceived in mono or stereo were sometimes performed on several channels by the composers themselves, using electroacoustic multichannel systems in the years following the realisation of these works.

The sound director mainly controls the dynamics of the performance and in some cases the localisation and movement of sounds. Some rare cases aside, there are no dynamic indications by the composers concerning the diffusion of the tape in the Fonologia works of the 1950s and 1960s, and it is then the sound director's task to interpret correctly the recorded music by defining the dynamic levels for performance; to this end, the background noise of the magnetic tape can often serve as a useful reference.

The size and acoustic characteristics of the listening space can, if the space is large and the acoustics not too generous, allow the expansion of the original dynamics of the tape without altering the musical balance, in order to give greater breath to pianissimo sounds at the threshold of audibility and to achieve a very effective fortissimo.

[TRANSCRIBED BY PASCAL DECROUPET]

Henri Pousseur. Three source texts concerning *Rimes pour différentes sources sonores*

1. *Ébauche d'une méthode*, excerpt from the unpublished end of the article that appeared in *die Reihe* 3 (1957), transcription of pages 37–38 of the typescript, dated October 1956.

Le premier de ces projets est celui d'une œuvre vocale et instrumentale spécifiquement radiophonique. Il était tout d'abord question d'employer les techniques de manipulation et de montage de la matière sonore enregistrée de manière à arriver, à partir des « données » d'un petit groupe d'instruments, à une œuvre synthétique qui, à la diffusion, à la transmission par *un seul* haut-parleur, présenterait des caractéristiques particulières, ne sortant pas des limites – d'ailleurs élastiques, comme nous l'avons déjà vu à propos du « Quintette à la mémoire de Webern » – de la *reconnaissabilité* des timbres, mais impossibles à réaliser d'une manière différente, par exemple lors d'une exécution directe. Cependant, la nécessité de pouvoir exécuter cette œuvre en salle de concert ayant été établie, le projet se précisa et changea quelque peu de visage. Il fut décidé de réserver une partie, une couche des événements sonores, pour la confier à des instrumentistes vivants, qui auraient, dès lors, à dialoguer avec la musique enregistrée. Du désir de spéculer sur la distribution spatiale des lieux d'émission sonore et d'en tirer une dimension structurelle supplémentaire pour l'œuvre elle-même, dimension fonctionnellement conforme à l'audition en salle et en même temps susceptible de rendre à celle-ci une vie, une imprévisibilité nouvelle, naquit finalement l'idée de la forme d'exécution que voici :

Quatres sources sonores seraient distribuées tout autour des auditeurs, aux « points cardinaux » de la salle. En face, à la place habituelle des interprètes, un orchestre de chambre, comprenant, outre les groupes normaux des bois, des cuivres et des cordes, un piano, une harpe et une percussion assez nourrie, avec xylophone. À la tête de cet ensemble, qui serait disposé de manière à permettre l'évolution spatiale des timbres, particulièrement la liaison structurelle avec les deux groupes voisins, l'habituel chef d'orchestre. Cependant, certains instrumentistes seraient parfois traités en solistes, et joueraient momentanément d'une plus grande indépendance par rapport à ce chef. Enfin, derrière l'orchestre, surélevé de manière à ce que le son passe par-dessus celui-ci, un groupe de chanteurs solistes, probablement un quatuor ou peut-être seulement un duo : soprano et baryton. Sur

le côté droit de la salle, à peu près vers le milieu des rangées de sièges, un piano solo, couplé avec un premier diffuseur ou groupe de diffuseurs. Sur le côté gauche, couplé avec une deuxième source électroacoustique, un groupe de quatre bois (flûte, hautbois, clarinette et basson). Enfin au fond, dans le dos des auditeurs, un troisième groupe de diffuseurs, cette fois à l'exclusion de tout musicien vivant.

On peut s'imaginer une œuvre qui commercerait par le dialogue concertant des seuls groupes « vivants », les deux groupes des côtés étant doués – par les méthodes que nous avons décrites à propos des « Fonctions » pour deux pianos – d'une relative liberté par rapport à l'orchestre de chambre. Progressivement les diffuseurs latéraux commenceraient à émettre des sons, tout d'abord des sons fournis par l'instrument ou par le groupe instrumental auquel ils sont couplés, et en nombre suffisamment réduit pour que leur entrée en jeu soit d'abord presque imperceptible. C'est par un enrichissement de la densité polyphonique que leur intervention serait ensuite rendue sensible à l'auditeur, la flûte, jouant seule du côté des bois, pouvant se trouver soudain « accompagnée » par une autre ou par tout un chœur d'autres flûtes, le piano paraissant se démultiplier et produire des masses de sonorités pianistiques dépassant ce que l'*oreille* sait être possible à cet instrument, etc. Puis les sons commenceraient à se transformer, par des manipulations spécifiquement électro-acoustiques : amplification de sons plus faibles par nature, etc., ce qui permettrait l'introduction, d'abord imperceptible, puis de plus en plus caractérisée, de sons différents, mais apparentés à ceux du groupe : cuivres et cordes frottées du côté des bois ; harpe, xylo et cordes pizzicato du côté du piano. Enfin, par l'intermédiaire de l'orchestre de chambre, dont la disposition aurait été conçue à cet effet, les sonorités spécifiques aux deux côtés, y compris les caractères sonores *travaillés* par les techniques électro-acoustiques, commenceraient à « voyager » l'une vers l'autre, jusqu'à ce qu'une confusion générale des timbres et des lieux d'émission se soit établie, jusqu'à ce que l'auditeur puisse se croire entouré de trois groupes à composition instrumentale semblable. C'est à ce moment qu'interviendrait pour la première fois le point cardinal manquant, le groupe de diffuseurs du fond de la salle, qui compléterait ainsi la pluridimensionnalité auditive, la possibilité de recevoir n'importe quel type de sonorité de n'importe quelle direction spatiale. Un nouvel élément de surprise serait alors introduit avec les premiers sons vocaux, produits par les chanteurs vivants (ou par l'un d'entre eux) par-dessus l'orchestre de chambre. Cette première intervention ferait taire momentanément tous les autres caractères sonores, tous les timbres instrumentaux, et l'auditoire se trouverait soudainement pris dans une grande structure « chorale », voire « multichorale » venant de tous les points cardinaux. Faisant suite à cette première *rupture* dans l'évolution (d'ailleurs rendue nécessaire du fait que cette évolution ne *pourrait* pas se poursuivre plus avant, qu'elle serait arrivée à son terme), apparaîtraient alors des structures caractérisées – entre autres – par des distributions, par des localisations toujours différentes, statiques ou dynamiques, des caractères sonores (qui ne seraient eux-mêmes pas uniquement définis

par la nature du *timbre*), par des champs structurels spatiaux toujours renouvelés, dont certaines directions, certains caractères discursifs seraient momentanément exclus, etc. L'articulation chronométrique générale de cette grande série de transformations pourrait être assurée par l'apparition de types structurels à un seul caractère et venant de toutes les directions, types structurels dont le passage exclusivement *vocal*, décrit précédemment, aurait constitué un premier exemple. Conforme à la variabilité interne, à l'imprévisibilité perpétuelle des structures musicales elles-mêmes, un mode semblable d'exploitation de l'espace auditif pourrait sans aucun doute rendre à la vie de concert, à la réception musicale collective, un intérêt supplémentaire, susceptible de satisfaire les exigences inédites d'une sensibilité nouvellement éveillée.

[the next paragraph contains references to *Gesang der Jünglinge* by Stockhausen and a project of «synthetic» composition» by Boulez combining live instruments and electroacoustic music]

2. *Rimes, sources différentes...*, Presentation typescript with manual corrections and suppressions, dated November 29th 1961.

Originally published in Swedish translation as « Rimma alla ni klangflöden », *Nutida Musik* 5/3 (1961–2), pp. 20–24, in continuation of a conference pronounced in Stockholm to introduce a concert on 26 January 1962, where *Rimes* was played by the Philharmonic Orchestra of Stockholm conducted by Sixten Ehrling. First french publication as «Rimes pour différentes sources sonores», *Textes et documents du Ministère des affaires étrangères et du commerce extérieur*, Bruxelles, 174 (15 November 1963), pp. 8–12. Version completed by the composer in 2003 published in Henri Pousseur, *Écrits théoriques 1954–1967*, choisis et présentés par Pascal Decroupet, Sprimont, Mardaga, 2004, pp. 161–166. The present version is based on a then unknown source recently found in the archive of the belgian musicologist and radio-producer Célestin Deliège; Irène Deliège kindly offered this document to the Paul Sacher Stiftung to complete the Sammlung Henri Pousseur in 2013. The paragraphs added by Pousseur in 2003 are given in footnotes.

Faire « rimer » des sons « naturels » (émis par les instruments de l'orchestre) et des sons « artificiels » (émis par la bande magnétique à travers les haut-parleurs), soit établir entre eux une correspondance, un échange et parfois une confusion des caractères, pouvant aller jusqu'au trompe-l'œil. Faire rimer entre elles des familles d'instruments originellement hétérogènes (comme les vents et la percussion), c'est-à-dire les réunir en une seule échelle progressive (fût-elle à plus d'une dimension), grâce aux formes sonores intermédiaires mises à jour par le premier projet. Faire enfin rimer plus profondément que jamais « forme » et « matériau » d'une composition musicale, en trouvant dans la matière sonore, grâce à sa malléabilité accrue, dans les chemins, dans les mouvements, dans le flux et le reflux de sa transformation permanente, l'étoffe même, les critères déterminants d'une structure formelle et de ses significations. Telle est la triple intention qui fit germer l'idée des *Rimes*, et que l'élaboration de celles-ci, échelonnée sur près de deux ans, permit

de clarifier peu à peu. C'est durant l'automne 1957 que la direction des Jeunesses Musicales Internationales, sur la proposition de Hermann Scherchen, qui devait diriger le concert, me demanda de composer une pièce pour un petit groupe de musiciens (de bons amateurs) et bande magnétique, pièce destinée à être exécutée par l'orchestre international qui serait mis sur pied à l'occasion du prochain congrès J.M. dans le cadre de l'Exposition mondiale de Bruxelles, en été 1958. Le projet me séduisait. Depuis plus d'un an, je pensais à la possibilité d'une composition pour bande magnétique, combinée avec des sources sonores dites naturelles. Cette idée, émise par Pierre Boulez dès l'apparition des premières réalisations de musique électronique, s'avérait de plus en plus comme une voie nécessaire (future provisoirement) de la recherche musicale. La musique électronique pure s'était révélée fort peu adéquate aux formes d'écoute propres au concert public habituel, lequel continuait à subsister, sans doute pour quelque temps encore, et dont on ne pouvait négliger les possibilités de diffusion. D'autre part, passée la première période de dépaysement, les sonorités électro-acoustiques développées (et surtout les plus valables), continuaient à se rattacher par beaucoup de côtés (par exemple l'association à une matière vibrante émettrice) à des représentations « naturelles ». Il semblait qu'il devait fatalement en être ainsi, et que c'est justement par une confrontation dialectique avec elles que l'on pourrait progressivement dégager leur spécificité, sans tomber dans un primitivisme trop rudimentaire. Je rencontrai donc Hermann Scherchen. Comme il comptait travailler par groupes séparés, il me demanda de ne pas utiliser les vents, requis déjà pour un autre numéro du programme, de ne pas dépasser le chiffre de dix-sept musiciens et de composer une pièce courte : quatre à cinq minutes. Je retins donc une formation composée exclusivement de cordes (4 violons, 3 altos, 2 cellos et deux contrebasses) et de percussion au sens large du mot, comprenant également une harpe, un piano (aussi célesta) et un vibraphone (aussi glockenspiel).

Enfin, nous nous préparions en ce moment (Hervé Thys, l'ingénieur Raymond Liebens et moi-même) à fonder le studio de musique électronique de Bruxelles (plus tard Apelac), et toute perspective de travail supplémentaire ne pouvait qu'étayer le projet.

Je conçus la forme de la pièce d'une manière assez démonstrative : commencer par l'orchestre seul. Puis faire insensiblement apparaître, aux haut-parleurs les plus proches (je disposais de diffuseurs implantés de manière fixe dans la salle où devait avoir lieu le concert : un groupe de chaque côté de la scène, un dans chaque coin arrière de la salle, ce dernier point exigeant d'ailleurs une légère modification de l'installation existante), des structures sonores simplement enregistrées, par un groupe orchestral de composition similaire. Peu à peu, j'y mêlerais quelques éléments hétérogènes (des sons de percussion artificiellement transposés et montés) et je ferais subir aux enregistrements des manipulations, discrètes mais déjà moins naturelles (tout d'abord, de l'écho ajouté). Progressivement, au cours

d'un processus polyphonique toujours dominé par l'orchestre (et soumis, comme l'ensemble de la pièce, et par exemple aux points de vue densitaire ou agogique, à des normes de composition sérielle), les sonorités enregistrées se déplaceraient vers l'arrière de la salle. Achevé ce processus de définition d'un espace englobant, extérieur à l'orchestre, apparaîtraient de plus en plus, au cours d'un développement où la bande magnétique tendrait à prendre une importance égale à celle des instruments, des phénomènes sonores artificiels, par exemple, des réverbérations présentées à l'envers, en commençant par la fin, préparant l'introduction de sonorités électroniques proprement dites. Celles-ci apparaîtraient d'abord discrètement, dans le remous d'un éclat culminant des sonorités « naturelles », mais tendraient rapidement, après quelques combinaisons en sens divers avec les différentes sonorités de l'orchestre et les sonorités enregistrées d'origine naturelle, à prendre une importance dominante, non seulement dans la composition de la bande, mais aussi, mettant celle-ci à l'avant-plan, dans l'équilibre général des « sources ». Les sons électroniques utilisés étaient d'origine relativement limitée : bruit blanc et suite d'impulsions lentes (moins de 20 à la seconde), périodiques ou non, filtrés et modulés, ainsi que, comme on va le voir, pour une fonction terminale très particulière, complexes de sons sinusoïdaux ; continuaient toujours à s'y mêler les éléments percutés introduits dès le début, et qui circulent d'un bout à l'autre de la bande magnétique comme des corpuscules unificateurs. Dans une montée irrésistible, ces sonorités « spécifiques » iraient jusqu'à couvrir complètement la voix de l'orchestre et à l'amener au silence. Je tenais en effet à manifester au moins une fois la puissance propre des haut-parleurs, et même cette intention avait contribué à définir mon projet formel. Mais cette énergie maximale, privée en quelque sorte de son support instrumental, de sa source directement « active », devait rapidement s'épuiser, et c'est dans la désinence générale que devaient apparaître, introduites par un discret retour instrumental, et constituant une nette éclaircie, les sonorités « sinusoïdales » (exactement, il s'agissait de complexes – à la structure harmonique typiquement « webernienne » – de *battements* de sons sinusoïdaux). Sauf quelques rappels percutants, elles restaient seuls maîtres de la bande magnétique, et se confondaient harmonieusement – mais sans plus rien abandonner de leur spécificité – aux sonorités également apaisées des instruments de l'orchestre.

On le voit, la « démonstration » dont j'ai parlé ne manquait pas d'aspects dramatiques. Je passai quelques semaines du printemps de 1958 (tout en travaillant à nos premières réalisations de musique « fonctionnelle », d'ailleurs pleines d'enseignement) à étudier les sons électroniques que je comptais utiliser (abandonnant pas mal de choses en cours de route que je ne maîtrisais pas encore assez bien). Je composai la partie instrumentale lors d'un séjour à Naples, que je fis pendant la première quinzaine de juin (c'était un festival des *Incontri musicali*), et consacrai les quelques semaines qui suivirent immédiatement mon retour à

réaliser (il était grand temps) la bande magnétique. Le concert devait avoir lieu fin juillet. Malheureusement, il y eut entre le chef d'orchestre et ses musiciens des dissensions, dont la responsabilité me semble avoir été fort partagée. Le concert n'eut pas lieu. Les *Rimes* furent créées en octobre, lors des *Journées de musique expérimentale*, également dans le cadre de l'Exposition. La direction était assumée par Bruno Maderna (à qui, avec Luciano Berio, l'ensemble de l'œuvre est dédié). Le succès dépassa mes espérances. La pièce dut être bissée. Ce fut pour elle le début d'une faveur publique périodiquement confirmée.¹

Mais la brièveté de la pièce constituait un évident handicap, et d'ailleurs, la recherche qui s'y effectuait, les principes qui s'y trouvaient définis (d'une manière encore embryonnaire) étaient loin d'être épuisés par elle, pouvaient aisément supporter de plus amples développements ; je décidai d'y ajouter une et peut-être plusieurs autres pièces. L'ensemble serait créé à Aix-en-Provence, lors d'un concert que l'orchestre symphonique de la R.T.B. devait y donner en juillet 1959, sous la direction de Pierre Boulez (en remplacement de Hans Rosbaud, malade).² Après d'assez longues préparations du matériau sonore, je composai et réalisai une deuxième pièce, plus longue que la première et dans laquelle je pus utiliser un plus grand nombre d'instruments : deux sextuors, composés chacun de deux bois, deux cuivres et deux cordes (groupés en deux trios hétérogènes) seraient couplés avec les deux groupes arrières de haut-parleurs, accusant la structure spatiale de la composition. Entre eux serait éventuellement disposée une deuxième percussion, comprenant clavecin amplifié et marimba (et que l'on peut placer à l'avant si ce n'est pas possible autrement). Un trio de bois viendrait enrichir l'orchestre principal.

La composition de cette pièce (l'actuel numéro 2) est basée sur une articulation beaucoup plus complexe, à la fois plus diversifiée et plus organiquement coordonnée, des sonorités, tant orchestrales qu'électroacoustiques.

La bande magnétique commence seule, avec des structures sonores à la fois douces et bruisantes (bruit blanc filtré, chaîne d'impulsions et autres sonorités électroniques apparentées, présentées sous un jour nouveau et dans de nouvelles fonctions par rapport à la première pièce). Au cours d'un développement long d'environ deux minutes, ces sonorités vont évoluer d'une manière très continue en direction du *son pur*, à hauteur parfaitement localisable (par exemple du son

1 Pousseur's addition in 2003, restoring in some way this last paragraph withdrawn for the publication in 1961, reads as follows : [Certains membres de l'orchestre international des J.M. ayant préféré visiter l'Exposition plutôt qu'assister régulièrement aux répétitions (de l'ensemble du programme, qui devait comporter une création de Xenakis et le *Sacre du printemps*), Hermann Scherchen partit en claquant les portes. Cette première partie fut donc créée le 9 octobre 1958, lors des *Journées internationales de musique expérimentale* qu'organisa l'Institut national belge de radiodiffusion (INR) à l'Exposition, par l'orchestre de chambre que dirigeait Bruno Maderna.]

2 The recording of this concert has been released on the CD *Henri Pousseur. Early Experimental Electronic Music 1954-61*, Sub Rosa SR415.

sinusoïdal). Ce développement emprunte deux chemins, soit polyphoniquement simultanés, soit alternatifs : le premier consiste à passer du *bruit* proprement dit, bandes de fréquences à remplissage statistique, à des complexes déjà plus sélectifs, plus structurés, à des « accords » de moins en moins denses, de moins en moins difficiles à analyser auditivement, et de là à des sons simples, à des hauteurs isolées, éventuellement superposées en couches polyphoniques, mais distinctes par le rythme, l'évolution dynamique, voire la localisation spatiale, sons d'abord pourvus d'un timbre très riche, très chargé en partiels harmoniques, puis de plus en plus simples, de plus en plus minces et dépourvus d'agressivité. L'autre chemin consiste à présenter les bruits de plus en plus modulés (trémolos, vibratos, etc.) et selon des périodicités de plus en plus régulières, puis, celles-ci établies, à les accélérer jusqu'à ce que leur fréquence de modulation devienne fréquence audible, d'abord très grave, puis plus aiguë, d'abord pourvue d'un spectre complexe, puis de plus en plus harmonique, jusqu'à rejoindre l'aboutissement de l'autre processus évolutif.

Lorsque la bande magnétique est arrivée à peu près à mi-chemin de cette évolution ramifiée, l'orchestre s'y mélange très insensiblement, faisant d'abord entendre des sonorités très bruisantes, pour lui les plus bruisantes, plus proches des bruits initiaux que ce qu'était la bande en ce même moment. Mais l'évolution de l'orchestre, similaire, se fera plus rapidement, de sorte que les deux grands partenaires arriveront en même temps au terme de cette évolution continue. À ce moment, la bande, qui a en quelque sorte amené l'orchestre dans son propre domaine (celui des sons harmoniques caractéristiques de la plupart de ses instruments) se retire du jeu, et l'orchestre (exactement : les trois groupes instrumentaux) continue seul son chemin. Les longues notes tenues sont peu à peu animées de mouvements dynamiques directionnels, parmi lesquels les *diminuendos* vont rapidement prendre le dessus : on est alors dans le domaine des sons amortis à longue résonance : piano, vibraphone, cloches, gong, etc. Mais certaines attaques se font plus sèches, et des phénomènes nettement *staccato*, d'ailleurs compensés dans leur durée par des spectres parfois de nouveau plus complexes, se superposent d'abord à la suite des résonances prolongées. Puis celles-ci disparaissent tout à fait et il ne reste que des constellations, assez espacées, de divers staccatos, sons ou bruits (à l'exception d'accords longuement tenus, très doux et tout à fait immobiles, qui subsistent à l'arrière-plan et préparent à leur façon l'évolution ultérieure des phénomènes dominants : les staccatos). Ceux-ci tendent dès lors à se grouper en petits amas très mouvementés ; ceux-ci tendent eux-mêmes à se condenser (plusieurs suites rapides de sons brefs se superposant, s'entrelaçant), puis à s'allonger ; leur pouvoir de déplacement « mélodique » se restreint proportionnellement et ils acquièrent une allure de plus en plus statique. Ils perdent ainsi leur caractère d'articulation formelle pour devenir de purs matériaux, à bouillonnement interne plus ou moins perceptible, et auxquels vont s'appliquer de grands mouvements dynamiques qui ne sont

pas sans rappeler ceux évoqués plus haut à propos des notes isolées. Mais vu leur caractère bruisant, c'est plutôt aux structures sonores du début qu'ils font finalement penser, en plus large, en plus puissant, en plus explosif : comme un rappel de faits structurels qui auraient pu se trouver *avant* le début de la pièce, ou se développer perpendiculairement à celle-ci.

La bande magnétique, qui avait fait très tôt quelques interventions discrètes, parfaitement intégrées aux sons instrumentaux, et qui, au cours du dernier processus décrit, s'était réaffirmée avec une importance croissante, émerge enfin et assume seule la fin de cette grande gradation énergétique, faisant entendre, tuilés, une série de longs *crescendos*, de bruits ou d'accords plus harmoniques, modulés ou non, qui se relayent et accumulent leur impétuosité jusqu'à faire éclater, à toutes les sources simultanées, une sorte de grand feu d'artifice, point culminant à tous les points de vue : vitesse, densité, mobilité « mélodique », puissance, distribution spatiale. Succédant à une augmentation de près de deux minutes, se développe alors un long *diminuendo*, qui s'étend jusqu'à la fin de la pièce : les explosions partielles qui continuent à éclater un peu partout sont de moins en moins fréquentes, de moins en moins denses, leurs longues périodes d'amortissement sont de plus en plus morcelées, jusqu'à ce que ne subsiste plus dans l'espace qu'un tissu toujours plus lâche de bribes, de lambeaux, eux aussi d'intensité décroissante, de sorte que les derniers groupes de son, clairsemés, ne sont pas sans rappeler, mais avec une toute autre fonction, les petites condensations dont toute cette grande vague (après les simples *staccatos*) était née.

Qu'on ne s'étonne pas de me voir faire un compte-rendu purement imagé de cette pièce : c'est ainsi qu'après avoir étudié les possibilités connectives du matériau sonore, des formes sonores élémentaires, j'en ai tout d'abord imaginé le déroulement : des méthodes plus rationnelles d'articulation ne sont à nouveau intervenues qu'au second degré : au stade de la réalisation détaillée de ce projet.³

Dès avant la création de cette deuxième partie, Pierre Boulez m'avait demandé de réserver au concert que l'ensemble instrumental du Domaine musical devait donner en octobre de la même année (1959) à Donaueschingen, la création d'une éventuelle troisième partie. Pour différentes raisons, parmi lesquelles j'avoue que se trouvait, mais non à l'avantplan, un certain manque de temps, je résolus de faire une pièce sans intervention enregistrée, mais dans laquelle j'utiliserais l'ensemble des instruments disponibles (à vrai dire, le choix de ceux-ci m'avait été dicté par l'éventualité de cette exécution, par les limites de l'ensemble prévu) : pièce courte, dès lors, avec une différence de durée à peu près proportionnelle à celle qui existe entre les deux autres pièces : environ trois minutes, et dont j'avais d'abord prévu qu'on pourrait la jouer aussi bien au début qu'à la fin de la suite. À l'expérience, cependant, et une fois la pièce composée,

tout d'abord, je décidai de la fixer à la fin : après le relatif tumulte que constitue toute la dernière moitié de la deuxième pièce, l'ensemble me semblait aisément supporter cette accalmie à peine interrompue par quelques vagues plus accusées. Il y aurait beaucoup à dire sur la composition de cette pièce, soumise à des critères d'organisation beaucoup plus stricts, beaucoup plus méthodiques, et cependant orientés vers une même représentation d'ensemble, et dans laquelle, malgré l'absence de sons enregistrés, je tâchai de ne rien abandonner de la ductilité sonore développée dans les deux précédentes. Mais cela sortirait quelque peu de notre sujet aujourd'hui, et prolongerait par trop ces « souvenirs » que menace déjà bien assez la complaisance.

-
- 3 The original publication in French ended here; in 2003, Pousseur added the following paragraph: [Après la création (en plein air) à Aix-en-Provence, Pierre Boulez me demanda d'écrire une troisième (et dans mon esprit dernière) partie, qui, ajoutée aux deux autres pourrait permettre à l'Ensemble du Domaine musical sous sa direction de donner la création intégrale du cycle lors du prochain festival de Donaueschingen, le troisième dimanche d'octobre de la même année. / Je n'avais pas le temps de faire jusque là un nouveau travail de studio, et je m'efforçai – pour reprendre une formule employée par Berg – de « faire de nécessité vertu ». Alors qu'entre les deux premiers volets existait un phénomène d'accroissement passant du seul orchestre à cordes et percussions sur la scène principale, et de la bande distribuée en trois points autour du public (un haut-parleur derrière l'orchestre, les deux autres dans les coins arrières), à un déploiement instrumental plus important, comportant en particulier des vents et se distribuant en (trois ou) quatre directions autour du public, le passage de la pièce centrale et « culminante » à la dernière consisterait en une chute globale (avec de nombreux paliers intermédiaires) du fait de la suppression pure et simple de la bande (et donc des haut-parleurs) mais du maintien de *tout* l'ensemble instrumental, comportant toutes les familles y compris les percussions et autres « sons amortis », et distribué tout autour du public. / Il ne résulte de cette réduction aucune impression de perte d'un élément constitutif essentiel. L'orchestre, pourrait-on dire, a appris à déployer une palette qui comporte suffisamment d'« intersections » (elles-mêmes suffisamment étendues) pour qu'on ait conscience d'être toujours dans le même « univers », passé à un état relativement plus calme (avec cependant quelques « crêtes ») convenant bien à sa fonction d'apaisement conclusif. (Alors que la deuxième pièce dure six minutes, celle-ci n'en dure que trois et demie.) / La création connut un très grand succès (dix minutes d'applaudissements) et l'œuvre fut jouée, au cours des années suivantes, dans de nombreuses villes importantes de toute l'Europe, de Paris à Munich, et de Stockholm à Rome, où Maderna réalisa un enregistrement pour le coffret vinyle *La musica moderna*.] This record is nowadays available either as part of the mentioned Sub Rosa SR415 or as part of the RCA/Victrola record VICS-1239 *The New Music* including pieces by Brown, Penderecki and Stockhausen (download through Amazon).

3. Presentation text for the «regenerated version» of *Rimes*, November 2005

Rimes pour différentes sources sonores (1958/9). Version régénérée (2005)

Ceux qui se rappellent cette « époque héroïque » (fut-ce pour avoir lu des choses à son sujet), savent que mes *Rimes* étaient la première œuvre sérielle pour orchestre et bande magnétique, mais ils savent peut-être aussi que cette bande, réalisée avec les moyens très élémentaires de notre tout jeune Studio de Bruxelles était simplement monaurale, et que lors des nombreuses exécutions qui eurent lieu en particulier dans les années 60, je la modulais en direct pour la faire passer sur un ou plusieurs des trois canaux de diffusion disposés autour du public : un « au milieu » de l'orchestre et deux dans les coins arrières de la salle, de manière à donner des impressions de division (cachées par les structures d'orchestre) et de mouvement de cette matière unique, cependant déjà assez riche dans ses caractères, entre le bruit le plus désordonné et des sons sinusoïdaux « animés » de battements, en passant par des enregistrements d'orchestre plus ou moins transformés et des sons percussifs périodiquement réitérés à des vitesses variables.

Pour l'exécution qui aura lieu à Turin en mars 2006, nous avons décidé de réaliser une idée qui nous poursuivait déjà depuis quelque temps. Il s'agissait, sans rien changer à la « matière première », de procéder à de véritables divisions de celle-ci et à leur distribution, fixe ou mouvante, dans l'espace où le public est plongé. Les responsables du studio Tempo Reale, de Florence, ont bien voulu se charger de ce travail, en collaboration avec moi. Une première visite à Florence au printemps 2004 m'avait permis de prendre connaissance des moyens disponibles et des techniques les mieux adaptées. Sur cette base, j'ai fait certaines propositions préparatoires, que mes amis de Tempo Reale ont réalisées avec beaucoup de soin et d'imagination ; elles plaçaient déjà (en procédant à une première séparation spectrale) les couches sonores conformément aux indications de la partition (assez précises dans la première partie, beaucoup plus vagues et globales – portant surtout sur les rapports de synchronisation – dans la deuxième, et tout à fait absentes dans la troisième, qui ne comporte plus d'autres sons que ceux de l'orchestre, ce qui ne réduit cependant pas la richesse sonore : dans la première partie, en effet, il n'y avait des musiciens que sur le plateau principal, tandis que plusieurs groupes, disposés autour du public, s'étaient ajoutés pour la seconde, et qu'ils continuaient à jouer dans la troisième ; d'ailleurs, l'écriture était telle qu'on pouvait affirmer que durant l'œuvre, l'orchestre avait « appris » à élargir sa palette aux dimensions de la bande).

À mon arrivée au studio en octobre 2005, après avoir visité l'auditorium de Turin et fait les propositions les plus appropriées pour le placement des groupes de musiciens et des haut-parleurs (dont nous savions déjà qu'ils seraient au nombre de huit, tous canaux indépendants), nous avons procédé à une distribution

supplémentaire de la matière sonore en affectant chacun des huit canaux d'une courbe spectrale propre et unique, et en distribuant ces « filtrages » (peu accusés) de telle sorte qu'il y ait grosso modo toutes les régions spectrales partout dans l'espace. Ainsi les sons, selon leur situation et composition fréquentielle (cependant déjà préalablement différenciée) se dispersent automatiquement dans toutes les directions voulues, y compris à l'intérieur de l'espace public, par exemple entre des haut-parleurs situés face à face ; les auditeurs se trouvent donc proprement baignés dans le son, une disposition microphonique venant encore quelque peu associer les sons d'orchestre (mais sans effets trop artificiels), à cette spatialisation, et celle-ci continuant donc à se faire sentir pendant la troisième partie.

Ainsi, l'œuvre connaît enfin une forme que je considère comme définitive, et pourra être réalisée en toute indépendance par n'importe quel effectif, orchestre et système informatico-électronique.

Transcription and text edition: Pascal Decroupet, 2016

About the authors

Angela Ida De Benedictis, PhD in musicology (Pavia University), post-PhD in Berlin with a grant of the Alexander von Humboldt Foundation on music and technology. Since 2014 member of the Scientific Board of the Paul Sacher Foundation (Basel), and curator of more than 25 manuscript collections (Berio, Boulez, Lachenmann, Maderna, among others). Director of the Centro Studi Luciano Berio and member of the Scientific Committee of the Archivio Luigi Nono. She was Assistant Professor at the University of Pavia. Her main research interests are theory and analysis featuring 20th-century music; electronic music; music and technology. Publications includes the writings of Nono (2000/2007, Eng. 2018) and Berio (2013), books and essays of theory and analysis, and critical editions of works by Berio, Berberian, Maderna, Nono and Togni.

Angela Ida De Benedictis' contribution in this book was translated from German by Lucas Bennett.

Pascal Decroupet, professor of Musicology at the Université Côte d'Azur, Nice, member of the research unit CTEL EA 6307. Studied in Liège (Belgium), Berlin and Paris; doctorate in Tours (France) on the ramifications of serial thinking in Boulez, Pousseur and Stockhausen. Publications and source-based analyses especially on music since 1945. Editor of two volumes of writings by Pousseur (Mardaga, 2004 and 2009) and the sketches and manuscripts of Boulez' *Marteau sans maître* (Schott, 2005). Currently working on a theory of sound-oriented («sonal») instrumental music.

Ulrich Mosch, professor of musicology at the University of Geneva. Studies in music and literature at the conservatory and the University of Hannover, doctorate in musicology at the Technische Universität Berlin. Between 1990 and 2013 he was curator of 25 collections of musical manuscripts at the Paul Sacher Foundation (Basel). After his habilitation (2005-13), he was a private lecturer at the University of Salzburg. He has also taught at the Universities of Basel and Zurich, as well as numerous other European universities and institutions of education. Specialising in music from the nineteenth to the twenty-first century, he is also interested in the relationship between music and other arts, including dance, film and fine arts, musical perception, the history of listening, musical interpretation and reproduction, and music in media.

Veniero Rizzardi is full professor at the State Conservatory of Padua and adjunct professor at the Ca' Foscari University in Venice. He has taught at the University of Freiburg (CH), at the IRCAM (Paris), and also been visiting professor in several universities in Europe and in the U.S. His research interests span from the genetic analysis of composition to the performance practice of electroacoustic music, and to the social history of sound. He has edited critical scores of works by Luigi Nono and Bruno Maderna, published essays and books on 20th-century music, including one on Miles Davis' recorded work. He was co-founder of the Luigi Nono Archive in Venice, where he serves as member of the board. He is also active as a curator and concert producer for the University of Padua. Together with Angela Ida De Benedictis (Paul Sacher Stiftung, Basel) he has edited various books, including the complete collection of Luigi Nono's writings (published in Italy by Ricordi and Il Saggiatore – English ed. by University of California Press, 2018).

Kilian Schwoon is professor for electroacoustic composition at the University of the Arts Bremen. He studied composition with Nicolaus A. Huber and electronic composition with Dirk Reith at the Folkwang Hochschule in Essen and then continued his studies with Luciano Berio at the Centro Tempo Reale in Florence. His interest in combining vocal, instrumental and electronic means has also led to an intensive activity as a performer and researcher in the field of live electronics. Furthermore, he develops sound installations and has participated in numerous audiovisual projects.

Germán Toro Pérez is composer, director of the ICST (Institute for Computer Music and Sound Technology) and professor for electroacoustic composition at the Zurich University of the Arts. His catalogue includes instrumental, electroacoustic and mixed compositions. His music theater work *Viaje a Comala* after *Pedro Páramo* by Juan Rulfo was premiered in May 2017. Recent publications include texts on artistic research, notation, analysis and performance practice of electroacoustic music. www.toro-perez.com

Alvise Vidolin, sound director, computer music researcher, and live electronics interpreter. He has provided his services to several important Italian and foreign institutions and has worked on the electronic realisation and performance of several composers' works.

He is co-founder and staff member of Centro di Sonologia Computazionale (CSC-University of Padova) where he is conducting his research activity in the field of computer assisted composition and performance, publishing various scientific works in the field of sound and music computing and multimodal systems. Since 1977 he has collaborated on various occasions with the «La Biennale» di

Venezia with special responsibility for the Computer Music Laboratory (LIMB). He held the Chair of Electronic Music at «B. Marcello» Conservatory of Music in Venezia from 1975 until 2009. He is a member of the scientific committee of Fondazione Archivio Luigi Nono and a member of the Istituto Veneto di Scienze Lettere e Arti.

Alvise Vidolin's contribution in this book was translated from Italian by Lucas Bennett.

Register

- Luciano Berio (1925–2003)
Différences, 43–45, 85; *Mimusique*, 26–27; *Momenti*, 28; *Mutazioni*, 28, 35, 37, 43–44, 45, 95, 115; *Perspectives*, 28, 95, 115–16; *Thema (Omaggio a Joyce)*, 20, 28, 79, 94, 95–96, 97, 116, 120–21; *Visage*, 17, 94, 127–30
- Luciano Berio and Bruno Maderna
Ritratto di città, 27
- Pierre Boulez (1925–2016) *Don*, 65;
Poésie pour pouvoir, 85
- John Cage (1912–1992)
Credo in US, 64; *Fontana Mix*, 31;
Imaginary Landscapes, 64
- Franco Evangelisti (1926–1980)
Incontri di fasce sonore, 72
- Mauricio Kagel (1931–2008)
Transición I, 63
- Gottfried Michael Koenig (*1926)
Essay, 63, 72, 94; *Klangfiguren II*, 79, 94; *Terminus I*, 63, 94
- György Ligeti (1923–2006)
Artikulation, 72; *Glissandi*, 13
- Bruno Maderna (1920–1973)
Ausstrahlung, 41; *Continuo*, 23, 28, 41, 116; *Hyperion*, 41; *Invenzioni su una voce*, 41; *Musica su due dimensioni* (1952), 64, 85; *Musica su due dimensioni* (1958), 9, 17, 26, 28, 41, 85, 93, 97–112, 115; *Notturno*, 16, 28, 34–41, 43, 45, 95, 115; *Sequenze e strutture*, 28, 115; *Serenata III*, 41; *Syntaxis*, 28, 41, 95, 115–16
- Luigi Nono (1924–1990) *A floresta é jovem e cheja de vida*, 9, 16, 53–60, 61, 118–19; *Contrappunto dialettico alla mente*, 60; *Die Ermittlung*, 53; *Il canto sospeso*, 46, 55; *La fabbrica illuminata*, 17, 46–53, 54, 57, 60–61, 97, 116–18, 123, 130–31; *Omaggio a Emilio Vedova*, 23, 46, 95, 96, 116; *Ricorda cosa ti hanno fatto in Auschwitz*, 53, 116–17, 123; *sofferte onde serene ...*, 17, 131–35; *Un diario italiano*, 46; *Un volto, e del mare*, 16, 60, 61; *Y entonces comprendió*, 60
- Henri Pousseur (1929–2009)
Exercices pour piano, 75; *Rimes pour différentes sources sonores*, 17, 65, 75, 84–86, 87–91, 137–47; *Scambi*, 16–17, 64–65, 74–84, 95; *Seismogramme*, 74; *Symphonies à quinze solistes*, 74; *Votre Faust*, 79, 81

Pierre Schaeffer (1910–1995) and
Pierre Henry (1927–2017)
Orphée, 85

Karlheinz Stockhausen (1928–2007)
Gesang der Jünglinge, 16, 63,
64, 65–74, 79; *Gruppen*, 65;

Klavierstück XI, 65; *Kontakte*,
66–67, 70, 85, 98; *Licht*, 69, 70;
Oktophonie, 98; *Studie I*, 63, 66;
Studie II, 63, 66

Edgard Varèse (1883–1965)
Déserts, 85; *Poème électronique*, 9

ZÜRCHER MUSIKSTUDIEN

Herausgegeben von
Dominik Sackmann

- Band 1 Horst Hildebrandt
Musikstudium und Gesundheit. Aufbau und Wirksamkeit eines präventiven Lehrangebotes.
Co-Autoren: Claudia Spahn, Matthias Nübling, Karin Seidenglanz und Marina Sommacal.
ISBN 3-906770-45-1. 215 Seiten. 2002.
- Band 2 Martin Neukom
Signale, Systeme und Klangsynthese. Grundlagen der Computermusik.
ISBN 3-03910-125-0. 2. unveränderte Auflage. 816 S. 2003, 2005.
- Band 3 Hans-Joachim Hinrichsen und Dominik Sackmann (Hrsg.)
Bach-Interpretationen. Eine Zürcher Ringvorlesung zum Bach-Jahr 2000.
ISBN 3-03910-108-0. 221 Seiten. 2003.
- Band 4 Dominik Sackmann (Hrsg.)
Bernhard Billeter – Musiktheorie und musikalische Praxis.
Gesammelte Aufsätze.
ISBN 3-03910-375-X. 369 Seiten. 2004.
- Band 5 Jörg Jewanski und Natalia Sidler (Hrsg.)
Farbe – Licht – Musik. Synästhesie und Farblichtmusik.
ISBN 3-03910-636-8. 528 Seiten. 2006.
- Band 6 Dominik Sackmann (Hrsg.)
Hindemith-Interpretationen. Hindemith und die zwanziger Jahre.
ISBN 978-3-03911-508-2. 308 Seiten. 2007.
- Band 7 Dominik Sackmann (Hrsg.)
Mendelssohn-Interpretationen
Der unbekannte Mendelssohn: Das Liedschaffen
ISBN 978-3-0343-0601-0. 181 Seiten. 2011.
- Band 8/1 Erich Schmid: Lebenserinnerungen
Band 1: Autobiographie
Herausgegeben von Lukas Näf
ISBN 978-3-0343-0533-4. 745 Seiten. 2014.

- Band 8/2 Erich Schmid: Lebenserinnerungen
Band 2: Briefe
Herausgegeben von Iris Eggenschwiler und Lukas Näf
ISBN 978-3-0343-0533-4. 851 Seiten. 2014.
- Band 8/3 Erich Schmid: Lebenserinnerungen
Band 3: Konzertprogramme und Radioaufnahmen
Herausgegeben von Lukas Näf unter Mitarbeit von Othmar Wüthrich
ISBN 978-3-0343-0533-4. 454 Seiten. 2014.
- Band 9 Dominik Sackmann (Hrsg.)
Burkhard-Interpretationen
Symposium 30./31. Oktober 2015
ISBN 978-3-0343-3301-6. 232 Seiten. 2018.
- Band 10 Germán Toro Pérez, Lucas Bennett (Hrsg.)
The Performance Practice of Electroacoustic Music
The Studio di Fonologia years
ISBN 978-3-0343-3118-0. 148 Seiten. 2018.