



Monitoring of **Mediterranean** **Coastal Areas**

PROBLEMS AND MEASUREMENT TECHNIQUES

EIGHTH INTERNATIONAL SYMPOSIUM
Livorno (Italy) June 2020



edited by

Laura Bonora, Donatella Carboni,
Matteo De Vincenzi





Monitoring of **Mediterranean** **Coastal Areas**

PROBLEMS AND MEASUREMENT TECHNIQUES

EIGHTH INTERNATIONAL SYMPOSIUM
Livorno (Italy) June 2020



edited by

Laura Bonora, Donatella Carboni,
Matteo De Vincenzi



PROCEEDINGS E REPORT

ISSN 2704-601X (PRINT) | ISSN 2704-5846 (ONLINE)

CNR - IBE
Fondazione Clima e Sostenibilità

Museo di Storia Naturale
del Mediterraneo Livorno

Eighth International Symposium

**MONITORING OF MEDITERRANEAN COASTAL AREAS:
PROBLEMS AND MEASUREMENT TECHNIQUES**

LIVORNO (ITALY) JUNE 2020

Patronized by

Università degli Studi di Firenze

Regione Toscana

Accademia dei Georgofili

Provincia di Livorno

Eighth International Symposium
“Monitoring of Mediterranean Coastal
Areas. Problems and Measurement
Techniques”

Livorno (Italy) June 2020

edited by
Laura Bonora, Donatella Carboni,
Matteo De Vincenzi

FIRENZE UNIVERSITY PRESS
2020

Eighth International Symposium “Monitoring of Mediterranean Coastal Areas. Problems and Measurement Techniques” : Livorno (Italy) June 2020 / a cura di Laura Bonora, Donatella Carboni, Matteo De Vincenzi. – Firenze University Press, 2020.
(Proceedings e report; 126)

<https://www.fupress.com/isbn/9788855181471>

ISSN 2704-601X (print)

ISSN 2704-5846 (online)

ISBN 978-88-5518-147-1 (PDF)

ISBN 978-88-5518-148-8 (XML)

DOI 10.36253/978-88-5518-147-1

Cover graphic design: Alberto Pizarro Fernández, Lettera Meccanica SRLs

Front cover: *Terrazza Mascagni Livorno* (Italy), photo by Gianni Fasano

Edited by: Laura Bonora, Donatella Carboni, Matteo De Vincenzi

Desktop publishing: Matteo De Vincenzi

Graphic Design: Gianni Fasano

FUP Best Practice in Scholarly Publishing (DOI https://doi.org/10.36253/fup_best_practice)

All publications are submitted to an external refereeing process under the responsibility of the FUP Editorial Board and the Scientific Boards of the series. The works published are evaluated and approved by the Editorial Board of the publishing house, and must be compliant with the Peer review policy, the Open Access, Copyright and Licensing policy and the Publication Ethics and Complaint policy.

Firenze University Press Editorial Board

M. Garzaniti (Editor-in-Chief), M.E. Alberti, F. Arrigoni, M. Boddi, R. Casalbuoni, F. Ciampi, A. Dolfi, R. Ferrise, P. Guarnieri, A. Lambertini, R. Lanfredini, P. Lo Nostro, G. Mari, A. Mariani, P.M. Mariano, S. Marinai, R. Minuti, P. Nanni, A. Novelli, A. Orlandi, A. Perulli, G. Pratesi, O. Roselli.

📖 The online digital edition is published in Open Access on www.fupress.com.

Content license: the present work is released under Creative Commons Attribution 4.0 International license (CC BY 4.0: <http://creativecommons.org/licenses/by/4.0/legalcode>). This license allows you to share any part of the work by any means and format, modify it for any purpose, including commercial, as long as appropriate credit is given to the author, any changes made to the work are indicated and a URL link is provided to the license.

Metadata license: all the metadata are released under the Public Domain Dedication license (CC0 1.0 Universal: <https://creativecommons.org/publicdomain/zero/1.0/legalcode>).

© 2020 Author(s)

Published by Firenze University Press

Firenze University Press

Università degli Studi di Firenze

via Cittadella, 7, 50144 Firenze, Italy

www.fupress.com

This book is printed on acid-free paper

Printed in Italy

ORGANIZING AUTHORITIES

**National Research Council of Italy
Institute of BioEconomy (CNR-IBE)**

Clima e Sostenibilità Foundation (FCS)

Natural History Museum of the Mediterranean

SCIENTIFIC COMMITTEE

Presidency

Donatella Carboni	<i>Department of Humanities and Social Sciences University of Sassari</i>
Fabrizio Benincasa	<i>National Research Council of Italy Institute of BioEconomy (CNR-IBE) Seat of Florence</i>
Simone Orlandini	<i>Department of Agriculture, Food, Environment and Forestry University of Florence Clima e Sostenibilità Foundation (FCS)</i>
Antonio Raschi	<i>National Research Council of Italy Institute of BioEconomy (CNR-IBE) Seat of Florence</i>
Laura Bonora (Scientific Secretariat)	<i>National Research Council of Italy Institute of BioEconomy (CNR-IBE) Seat of Florence</i>
Matteo De Vincenzi	<i>National Research Council of Italy Institute of BioEconomy (CNR-IBE) Seat of Florence</i>
<i>Coordinator of the Scientific Secretariat</i>	

Session Underwater and Coastal Cultural Heritage

Marinella Pasquinucci	<i>University of Pisa</i>
Fabrizio Antonioli	<i>ENEA – Casaccia Laboratory for Climate Modeling and Impacts</i>
Giovanna Bianchi	<i>Department of History and Cultural Heritage University of Siena</i>
Giulio Ciampoltrini	<i>Superintendence for Archaeological Heritage of Tuscany</i>
Tessa Matteini	<i>Department of Architecture University of Florence</i>

Session Coastline Geography and Coastal Landscapes: territorial dynamics and integrated protection

Gloria Pungetti	<i>Department of Humanities and Social Sciences University of Sassari</i>
Rossella Bardazzi	<i>Department of Economics and Management University of Florence</i>
Biagio Guccione	<i>Department of Architecture University of Florence</i>
Ilaria Lolli	<i>Department of Law University of Pisa</i>
Tessa Matteini	<i>Department of Architecture University of Florence</i>
Carlo Natali	<i>Department of Architecture University of Florence</i>
Claudio Saragosa	<i>Department of Architecture University of Florence</i>
Stefano Soriani	<i>Department of Economics University of Venice</i>
Alessio Valente	<i>Department of Science and Technology University of Sannio Benevento</i>

Session *Morphology and evolution of coastlines and seabeds*

Giovanni Sarti *Department of Earth Sciences University of Pisa*
Duccio Bertoni *Department of Earth Sciences University of Pisa*
Filippo Catani *Department of Earth Sciences University of Florence*
Corinne Sabine Corbau *Department of Physics and Earth Science
University of Ferrara*
Giuliano Gabbani *Department of Earth Sciences University of Florence*
Sandro Moretti *Department of Earth Sciences University of Florence*

Session *Flora and Fauna of the littoral system: dynamics and protection*

Davide Travaglini *Department of Agriculture, Food, Environment and Forestry
University of Florence*
Carla Cesaraccio *National Research Council of Italy
Institute of BioEconomy (CNR-IBE) Seat of Sassari*
Anna Roselli *Natural History Museum of the Mediterranean, Livorno*
Federico Selvi *Department of Agriculture, Food, Environment and Forestry
University of Florence*
Roberto Tognetti *Department of Agricultural, Environmental and Food Sciences
University of Molise*

Session *Coastal Environmental Engineering: pollution, energy production, monitoring and economic environmental assessment, regulatory context*

Marcantonio Catelani *Department of Information Engineering University of Florence*
Rossella Bardazzi *Department of Economics and Management
University of Florence*
Carlo Carcasci *Department of Industrial Engineering University of Florence*
Giuliano Gabbani *Department of Earth Sciences University of Florence*
Ilaria Lolli *Department of Law University of Pisa*
Giampaolo Manfrida *Department of Industrial Engineering University of Florence*

Organizing Committee:

Gianni Fasano	CNR – IBE Seat of Florence	(Coordinator of Committee)
Alessandro Materassi	CNR – IBE Seat of Florence	
Laura Pellegrino	CNR – IBE Seat of Livorno	
Federica Zabini	CNR – IBE Seat of Florence	
Francesca Chellini	FCS Florence	

Organizing secretariat:

CNR-IBE Area di Ricerca di Firenze
Via Madonna del Piano 10,
50019 Sesto Fiorentino (Florence - Italy)
Phone +390555226557
e-mail: segr.org@ibe.cnr.it

Scientific Secretariat:

CNR-IBE Area di Ricerca di Firenze
Via Madonna del Piano 10,
50019 Sesto Fiorentino (Florence - Italy)
Phone +390555226060-6030
e-mail: simposio@ibe.cnr.it

INDEX OF PAPERS

Preface	XIII
Introduction	XV
F. Benincasa, M. De Vincenzi, G. Fasano <i>Alexander von Humboldt, da 250 anni il teorizzatore dello studio interdisciplinare dell'ambiente</i>	XVII
Session: Underwater and Coastal Cultural Heritage	1
Chairman: Marinella Pasquinucci	
G. Cera <i>Understanding the settlement dynamics of the Ionian coastal area of Salento (Puglia, Southern Italy): the contribution of the new archeological data from the fortified Messapian centre at Li Schiavoni</i>	7
V. Coletta, F. Prestileo, P. Allasia, A. Bonazza, A. Ciarravano, S. Federico, D. Notti, R. C. Torcasio, M. Crespi, S. Dietrich <i>Pyrgi: analysis of possible climatic effects on a coastal archaeological site</i>	17
L. Corniello, A. Burda, A. Trematerra, D. Carleo, A. De Cicco, M. Gargiulo, F. Guerriero, G.P. Lento <i>The Monastic heritage in the Saronic Gulf (Greece). Architectural and environmental survey of the architecture and coastline.</i>	28
M. C. de Francesco, M. Zappalorto, D. de Francesco, M. Mangifesta, A. Faraone, M. Paluzzi, C. Minciarelli, G. Tatasciore, A. R. Natale <i>Archeological findings of ancient harbor in the pilot site of Interreg Adrion APPRODI project in Ortona (Ch, Abruzzo), central Adriatic Sea</i>	38
F. Fabrizio <i>Il parco archeologico di Saturo (Leporano-TA) millenni di storia, decenni di incuria</i>	47
I. Ferrari, A. Quarta <i>San Cataldo (Lecce, Italy): the historical evolution of the coastal landscape</i>	58
M. Fontana <i>Another Sicily, tuna-fishing structures and landscape: a diachronic and contemporary photographic journey along the Sicilian Western coast</i>	69
G. Grigatti, P.P. Peruccio <i>Il design sistemico per la valorizzazione del patrimonio faristico italiano</i>	79
A. Ivona <i>Coastal heritage and territorial signs</i>	85

R. Martín, V. Yepes, A. Grindlay	95
<i>Discovering the marina's cultural heritage and cultural landscape</i>	
L. Montioni, A. Del Corona, I. Palano, F. Pichi, M. Scamporrino	105
<i>Evaluation and monitoring of the Livorno's Fossi System</i>	
A. Pellegrini, A. Asta	117
<i>Evolution of the coastal landscape in eastern Veneto: new data from preventive archaeology</i>	
P. Tartara	127
<i>Along the Ceretan coast and forward on</i>	
S. L. Trigona	137
<i>Archeologia subacquea in Liguria un progetto integrato per la tutela e la valorizzazione</i>	
Session: Coastline Geography and Coastal Landscapes: territorial dynamics and integrated protection	147
Chairman: G. Pungetti	
S. Altavilla, A. Caligiore, J. Ceccarelli, G. Corrente, F. Galeano, G. Pappacena, M. Pisconti, A. Petrillo, F. Rottino, P. Puri, G. Scatigna, F. Simione, T. Sinesi, G. Spaccavento, C. Ubaldi	155
<i>Environmental training of the Italian Coast Guard between tradition and innovation</i>	
T. Bisiani, M. Savron	164
<i>New scenarios for a development between infrastructures and innovation</i>	
A. Casu, J. Zaccagna	174
<i>New features of the rivershore: climate change and new relations between town and water</i>	
A. Cazzani, S. Barontini	183
<i>Lake Garda lemon houses: a Mediterranean landscape in an internal lake</i>	
C. Corbau, M. Contini, V. Gazale, A.L. Lazarou, U. Simeoni, D. Carboni	194
<i>Distribuzione del marine litter nelle spiagge della Sardegna: il caso di Cala dei Ponzesi e di Cala Spalmatore nell'isola dell'Asinara</i>	
D. De Marchi, M. Lalli, A. Mancini	214
<i>Monitoring online perception of environmental issues on coasts of Sicily</i>	
F. Epifani, F. Pollice,	219
<i>Stabilimenti balneari come presidi ambientali. Verso la multifunzionalità dei servizi di balneazione. Alcune riflessioni a partire dal progetto Interreg RE.CO.RD.</i>	
M. A. Esposito, F. Bosi	229
<i>LaCoast Atlas: a consistent database to support sustainable coastal zone management</i>	
A. Ghersi	242
<i>CAPO MELE: a story-telling experimental beach in Laigueglia (SV)</i>	

G. N. M. Giudici, F. Jannuzzi, S. Patrizio, F. Pisani Massamormile	250
<i>The coastal lakes of Campi Flegrei: between biodiversity and anthropization</i>	
I. Lolli	259
<i>The management of dredged materials: the «long and winding road» from waste to resource</i>	
G. Mazzeo	270
<i>Domitian coast. Rehabilitation' outlooks of the Northern coast of Campania</i>	
I. Palano A. Del Corona, L. Montioni, F. Pichi, M. Scamporrino	280
<i>Strategic Planning Document of Port Authority System, a new city-ports agreement: the case of Northern Tyrrhenian Sea AdSP</i>	
A. M. Pidalà	289
<i>Le coste dei Nebrodi tra mosaico paesaggistico, beni culturali e criticità complesse. Visioni e scenari strategici progettuali nel paradigma della sostenibilità</i>	
M. Russo	299
<i>Salerno: il porto e le metamorfosi del waterfront</i>	
J. Salaün, S. Pioch, J. C. Dauvin	309
<i>Artificial reef along the French Mediterranean coastline: toward innovative integrated biodiversity management</i>	
C. Saragosa, M. Chiti	316
<i>Spatial configurations and flows in the morphogenetic processes of settlements. A planning experience on the Tuscan coast</i>	
M. Scamporrino	326
<i>View Management in city-port landscapes. Livorno applicative experience</i>	
G. Tagarelli, N. Cantasano, T. Caloiero, G. Pellicone	338
<i>Integrated Coastal Zone Management of Natura 2000 and cultural heritage sites in calabrian coastal landscape (southern Italy)</i>	
A. Venudo, V. Rodani, V. Devescovi	348
<i>Lagoon scenarios for the Bassa Friulana plain: a flooding archipelago</i>	
F. Zullo, L. Fiorini, A. Marucci, B. Romano	363
<i>Analysis of the theoretical settlement scenario implemented by the municipal plans. The case study of the Romagna coast municipalities</i>	
Session: Morphology and evolution of coastlines and seabeds	375
Chairman: G. Sarti	
R. Bedini, P. Colantoni, C. Pergent-Martini	379
<i>Coastal erosion in the Gulf of Follonica and Baratti and coastal defense methods</i>	

O. Bulkan, B. Yalamaz, M.Namık Çağatay	385
<i>A sedimentological pattern of a coastal transitional environment: from the Eastern Mediterranean Sea shoreline through the Lake Bafa</i>	
A. Di Leo, S. Giandomenico, L. Spada, N. Cardellicchio, F. P. Buonocunto, E. Esposito, L. Ferraro, L. Giordano, A. Milia, C. Violante	392
<i>The offshore environmental impact by Sarno River in Naples Bay (South-west Italy)</i>	
M. Di Natale, S. Di Ronza, C. Eramo	402
<i>Water circulation in coastal marine areas - case studies</i>	
P. Gomes da Silva, A.L. Beck, J. Martinez Sanchez, R. Medina Santamaria, M. Jones, A. Taji	412
<i>Advances on coastal erosion assessment from satellite Earth Observations: exploring the use of Sentinel products along with very high resolution sensors</i>	
I. Kadri, F. Atroune	422
<i>Diachronic evolution of the coastline of Bordj El Kiffane (Algiers, Algeria) in absence and presence of coastal protection structures</i>	
I. López, J. I. Pagán, A. J. Tenza-Abril, L. Aragonés, L. Bañón	432
<i>Relationship between shoreline evolution and sediment wear</i>	
J. I. Pagán, I. López, L. Aragonés, A. J. Tenza-Abril	441
<i>Experiences with beach nourishments on the coast of Alicante, Spain</i>	
G. Piccioli-Resta, S. Fai, A. Picciolo	451
<i>Drone Remote Sensing for coastal habitats protection</i>	
K. Pikelj, N. Furčić	462
<i>Impact of cliff erosion on marine sediment composition - indication of local coastline evolution (Vrgada Island, Croatia)</i>	
Session:	Flora and Fauna of the littoral system:
	dynamics and protection
Chairman:	D. Travaglini
B. Akçali, E. Taşkin, G. Kaman, A. Evcen, H. Çalık, O. Akyol	475
<i>Posidonia oceanica monitoring system on the coast of Aegean Sea of Turkey</i>	
L. Beccarisi, C. G. Giannuzzi, G. D'Andria, M. Greco	483
<i>Habitat and flora monitoring in the Regional Nature Reserve of "Palude del Conte e Duna Costiera di Porto Cesareo" (Puglia, Italy)</i>	
R. Bedini, M. Bedini, E. Salvadori	492
<i>A new transplanting method of Posidonia Oceanica (Linnaeus) Delile, 1813 plants</i>	
A. F. Bellia, J. Evans, S. Lanfranco	501
<i>A Drone's Eye View: a Preliminary Assessment of the Efficiency of Drones in Mapping Shallow-Water Benthic Assemblages</i>	

G. Bellissimo, B. Sirchia, V. Ruvolo	510
<i>Monitoring of Posidonia oceanica meadows in the Sicilian coasts under the Water Framework Directive (WFD)</i>	
G. Bellissimo, B. Sirchia, V. Ruvolo	519
<i>Assessment of the ecological status of Sicilian coastal waters according to a macroalgae based index (CARLIT)</i>	
M. C. de Francesco, I. Chiuchiarelli, L. Frate, M. L. Carranza, T. Pagliani, A. Stanisci	529
<i>Towards new marine-coastal NATURA 2000 SITES in the central Adriatic Sea</i>	
H. Humeniuk, O. Voloshyn, V. Voloshyn	540
<i>Seasonal dynamics of cadmium and plumbum in the Turia and Pripjat rivers</i>	
H. Idmoussi, L. Somoue, K. Hilmi, O. Ettahiri, T. Baibai, A. Makaoui, A. Errhif	547
<i>Phytoplankton assemblage Characterization along the Mediterranean coast of Morocco during autumn</i>	
C. Ippoliti, S. Tora, C. Giansante, R. Salini, F. Filipponi, E. Scamosci, M. Petrini, N. Di Deo, A. Conte	557
<i>Sentinel-2 e campionamenti in situ per il monitoraggio delle acque marine dell'Abruzzo: primi risultati</i>	
M. Morel, B. Lapierre, A. Goossens, E. Dieudonné, P. Lenfant, L. Vasseur, V. Hartmann, M. Verdoit-Jarraya	569
<i>Métiers, effort and catches of a Mediterranean small-scale coastal fishery: the case of the Gulf of Lion marine natural Park</i>	
F. V. Romano, V. Scalcione, P. D'Antonio, C. D'Antonio, E. Lacetra	580
<i>Precision agriculture and conservation of coastal landscapes</i>	
C. Rugge, G. Ciccarese, A. Longo, S. Petrachi, M. M. Niceta Potì	586
<i>Interventi di tutela e valorizzazione della biodiversità del SIC "Torre dell'Orso"-IT 9150004</i>	
D. Sgambati, É. Moura, A. E. Said, L. Rueda, E. Hoarau, L. Pribelja, D. Kļaviņš, A. Fagnano, A. De Angelis, A. Miccio	597
<i>Monitoraggio, conservazione e informazione nella baia di Ieranto: un modello circolare per la gestione delle Aree Marine Protette</i>	
M. Simeone, M. Solano, P. Masucci, S. Mecca, E. Barra	610
<i>5 anni di monitoraggio, controllo e prevenzione della pesca illegale nel Parco Sommerso di Gaiola (golfo di Napoli)</i>	
R. Stocco, L. Pirrera, E. Cellini	620
<i>L'applicazione di tecniche innovative nel monitoraggio costiero degli habitat prioritari</i>	
E. Taşkin, İ. Tan, O. Minareci, E. Minareci, H. Atabay, Ç. Polat Beken	632
<i>The pressures and the ecological quality status of the Marmara Sea (Turkey) by using marine macroalgae and angiosperms</i>	

Session:	Coastal Environmental Engineering: pollution, energy production, monitoring and economic environmental assessment, regulatory context	639
Chairman:	M. Catelani	
A. Bono, M. Marini	<i>Renewable power sources in coastal areas. A viability assessment in the scope of needs and regulation</i>	645
A. Cioffi, F. Cuculo, L. Di Nucci, G. Orlando	<i>The economic-environmental impact analysis in the choice of the management of the dredging materials of a port basin in relation to the classification and the quality: the experience of the port of Termoli (2018)</i>	656
D. Colarossi, P. Principi	<i>Feasibility study of a cold ironing system and district heating in port area</i>	666
M. De Vincenzi, G. Fasano	<i>Monitoring coastal areas: a brief history of measuring instruments for solar radiation</i>	676
A. Di Cicco, R. Gupana, A. Damm, S. Colella, F. Angelini, L. Fiorani, F. Artuso, V. E. Brando, A. Lai, A. Genangeli, F. Miglietta, R. Santoleri	<i>“FLEX 2018” cruise: an opportunity to assess phytoplankton chlorophyll fluorescence retrieval at different observative scales</i>	688
J. Droit	<i>Careening areas in marinas, anchorages, and private shipyards. Status of implementation of the MSFD measure</i>	698
F. Figueredo, F. Girolametti, S. Illuminati, C. Truzzi, A. Annibaldi, S. Susmel	<i>Electrochemical phosphate detection in oligotrophic seawater with a stand-alone plastic electrode</i>	705
N. Ghirardi, M. Bresciani, G. Luciani, G. Fornaro, V. Zamparelli, F. De Santi, G. De Carolis, C. Giardino	<i>Mapping of the risk of coastal erosion for two case studies: Pianosa island (Tuscany) and Piscinas (Sardinia)</i>	713
P. Ventura, M. Palmarocchi	<i>New coastal protection and sea energy production</i>	723
	<i>Index of Authors</i>	737

Preface

2019 was the 250th year since the birth of Alexander von Humboldt, a nature scholar. He was born in Germany and lived in many parts of the world, giving a unified vision of this, where organic and inorganic nature form a single system, whose manifestations are all connected to each other.

Since our Symposium, with its interdisciplinarity, intends to demonstrate, edition after edition, this thesis we seemed appropriate to remember the theorist of this holistic view of Nature. Since the Symposium is held in even years, and in 2019 it was not foreseen, we intended to take the occasion to celebrate Humboldt in 2020 edition.

It would have been interesting to remember him during the traditional three days of Symposium but unfortunately could not be carried out due to the COVID-19 pandemic restrictions. The pandemic also led to a reduction of the works; from the approximately 150 works selected by the Scientific Committee, in these Proceedings only half of them are present for obvious reasons. In any case, it seemed appropriate, giving a clear sign of continuity, to publish the works that the authors were able to complete in this difficult period.

In this reduced edition, the celebration of Humboldt was ensured by F. Benincasa, M. De Vincenzi, G. Fasano with a note that we place before the works of the different Sessions.

The Editors

INTRODUCTION

ALEXANDER VON HUMBOLDT, DA 250 ANNI IL TEORIZZATORE DELLO STUDIO INTERDISCIPLINARE DELL'AMBIENTE

Fabrizio Benincasa, Matteo De Vincenzi, Gianni Fasano
CNR Institute of BioEconomy via Madonna del Piano 10 Sesto Fiorentino (Florence, Italy)
phone +39 055 5226058; e-mail fabrizio.benincasa@ibe.cnr.it

Abstract – In the 19th century, the term scientist was coined to indicate, in general, a cultivator of the sciences. This definition involved both the beginning of the professionalization of Sciences and the end of the "eclectic scholar" of Nature, of which Aristotle was the prototype and Alexander von Humboldt (1769-1859) was its last important exponent. Humboldt was a polymath, explorer, prolific writer, experimenter, university lecturer; he dealt with geology, geography, oceanography, astronomy, meteorology, climatology, botany, philosophy, anthropology, etc. He was the most famous scholar of sciences of his time.

Humboldt, with his works, has managed to connect all disciplines in a unified view of the world. In his conception organic nature and inorganic nature form a single system of active forces and all the organisms of the Earth are linked as a family sharing the same "home". In 1866 Ernst Haeckel called the Humboldt's holistic view *ecology* (from the Greek *oikos*, home, and *logos*, study) meaning the whole science of the relationship of the environment with the surrounding environment. A scientific world now organized in increasingly limited and specialized fields soon forgot Humboldt's holistic interdisciplinary vision, but his principles remained. Humboldt showed Nature as a single force with climatic zones that corresponded to each other across continents. He argued that the plants were not to be arranged according to taxonomic categories of belonging, but they had to be considered in relation to the climate and location. In our time, given the anthropic damage caused to Nature, it is necessary to consider again Humboldt's unitary vision, establishing interdisciplinary connections between scholars of the various disciplines, thus expanding knowledge in a more organic and global vision of the Environment.



Figura 1 - Alexander von Humboldt (1843). Ritratto di J. K. Stieler (1781 - 1858), particolare, olio su tela 107 × 87 cm, Coll. Schloss Charlottenhof, Potsdam - Germania [101].

Figure 1 - Alexander von Humboldt (1843). Portrait by J. K. Stieler (1781 - 1858), detail, oil on canvas 107 × 87 cm, Schloss Charlottenhof Coll. Potsdam - Germany [101].

1. Introduzione

Nel 1834 William Whewell (Lancaster, 1794 - Cambridge 1866), filosofo e naturalista inglese, nella sua recensione del libro *On the Connexion of the Physical Sciences* di Mary Somerville [31] coniò il termine

scienziato, ma usò espressioni un po' troppo ironiche per essere preso subito sul serio [37]. Sei anni dopo, nel suo libro *Philosophy of the Inductive Sciences* [38, vol. 1 p. 113] riprese il suggerimento, questa volta in modo più sobrio e il termine *scienziato* fu accettato dalla comunità scientifica per descrivere un "coltivatore" di scienze in generale. Ebbe così inizio la "professionalizzazione" delle scienze che si allontanavano sempre più dalla Natura per entrare nei laboratori e nelle università, separandosi in discipline distinte con piccole zone di contatto e talvolta di sovrapposizione. Torneremo su questi aspetti alla fine di questo lavoro.

2. I precursori di Humboldt

La definizione di scienziato determinò l'inizio della fine dello "studioso eclettico" della Natura di cui possiamo vedere in Aristotele (Stagira, 384 a.C. o 383 a.C. - Calcide, 322 a.C.) il prototipo e in Alexander von Humboldt (Berlino, 1769 – ivi, 1859), figura 1, l'ultimo esponente; scrittore prolifico, sperimentatore con buone basi scientifiche, viaggiatore e studioso di tutti gli ambienti terrestri allora conosciuti. Si occupò di geologia, geografia, oceanografia, astronomia, meteorologia, climatologia, elettrologia, botanica, anatomia, filosofia, antropologia, ecc., nell'affannosa ricerca di una sintesi fra scienza e cultura umanistica. Egli fu, senza dubbio, lo scienziato più famoso del suo tempo, non solo in Europa ma nel Mondo: noto agli accademici ma anche alla gente comune.

Fondamentale per la sua formazione umanistica fu l'incontro con il celeberrimo scrittore, ma anche apprezzato fisico e naturalista, Johann Wolfgang von Goethe (Francoforte sul Meno, 1749 - Weimar, 1832), figura 2; gli argomenti da loro trattati erano i più diversi, si andava dalla poesia alla anatomia delle rane. Ma una delle questioni centrali delle loro discussioni, che peraltro impegnava i pensatori di tutta Europa, era: *come si può comprendere la Natura*. Per gli *empiristi* bisognava verificare le teorie tramite rilevamenti sperimentali, per i *razionalisti* una tesi era sufficientemente dimostrata se basata sulla logica e il ragionamento. Goethe, che ammirava il geografo-filosofo Immanuel Kant (Königsberg, 1724 – ivi, 1804), figura 3, tanto da aver letto tutte le sue opere, sosteneva che si può arrivare a una verità oggettiva soltanto combinando l'esperienza con la capacità di ragionamento dell'osservatore: "*i sensi non ingannano, il giudizio sì*" [7, n. 1193].

Illuminante su questo aspetto fu, per Humboldt, il pensiero di Kant il quale sosteneva che la conoscenza è una struttura sistematica i cui singoli fatti, per avere un senso, devono inserirsi in una cornice più ampia: "*prima di costruire una casa, mattone su mattone e pezzo per pezzo bisogna avere una idea dell'aspetto che dovrà avere l'intero edificio*" [22, prefazione vol. I, p. XXIII]. Fu questo concetto di *sistema* che divenne il fulcro del pensiero di Humboldt.

In sostanza Humboldt può essere definito un illuminista nel senso kantiano, anche se Kant è uno dei pochissimi grandi del suo tempo che egli non ebbe modo di conoscere



Figura 2 - Johann Wolfgang von Goethe (1828). Ritratto di J. K. Stieler, particolare, olio su tela 78 × 63 cm, Neue Pinakothek Monaco - Germany [102].
Figure 2 - Johann Wolfgang von Goethe (1828). Portrait by J. K. Stieler, detail, oil on canvas 78 × 63 cm, Neue Pinakothek Monaco - Germany [102].

personalmente. Humboldt era partito dall'Europa quando la fama del grande filosofo si era appena imposta, ed era tornato dopo la sua morte, quando Kant cominciava ad essere messo in discussione dagli *idealisti*.

Di un incontro, sia pure epistolare, fra i due scienziati, ne parla Daniel Kehlmann in [23, pp. 66-67] dove dice che Humboldt, durante il suo viaggio in America tropicale, scrisse a Kant dicendo che, in base ai suoi propri rilevamenti, stava elaborando il concetto di una nuova Geografia Fisica e si dichiarava grato di tutti i suggerimenti che l'illustre geografo avrebbe voluto dargli. Di questa lettera non si trova traccia e più che una documentazione storica sembra il frutto della fantasia dell'immaginario autore, la cui opera è di fatto un romanzo in cui si intrecciano "furbescamente" fatti e finzioni. Kant non ha mai trascritto in un volume i suoi appunti delle lezioni di geografia fisica ma lo ha fatto fare ad alcuni suoi assistenti, che hanno utilizzato anche gli appunti degli studenti, in conseguenza di ciò esistono varie edizioni di Geografia Fisica kantiana. In alcune di queste vi sono anche *aggiornamenti geografici* non kantiani o parti kantiane omesse. Rifacendosi alla versione che nel 1923 venne accolta nella "edizione dell'Accademia" degli scritti kantiani, possiamo dire che Kant fosse a conoscenza dell'attività di Humboldt nelle Americhe poiché se ne parla in Geografia Fisica volume III [22, pp. 561, 565]. Resta di fatto che Humboldt partì dall'Europa kantiano e kantiano vi ritornò, e rimase tale fino alla fine [28, p. 49].

Il rapporto con Goethe e la visione filosofica di Kant influirono sul pensiero di Humboldt che passò dalla ricerca puramente empirica a una propria interpretazione della Natura, combinando la precisione dei dati scientifici con la risposta emotiva all'armonia di ciò che vedeva. Così dopo una stretta concezione illuministica cominciava ad apprezzare anche la percezione e la soggettività dell'individuo, ma senza dare quella interpretazione edenica della natura [28, p. 48 nota 6] espressa dai *romantici*. A differenza di questi Humboldt pensava che l'armonia della natura non andasse colta attraverso un sapere empatico ma attraverso l'uso duttile e flessibile della ragione [28, p. 49].

La formazione politica di Humboldt si consolidò certamente con la Rivoluzione francese (1789) che insinuò nel giovane Alexander, vissuto circondato da pensatori *illuministi*, un credo nella libertà, nell'uguaglianza, nella tolleranza, nell'importanza dell'istruzione che non l'abbandonò mai.

Humboldt, a quindici anni dalla Rivoluzione francese, voleva conoscere gli uomini che, a suo dire, avevano riversato gli ideali della Rivoluzione nella giovane repubblica americana, in particolare il terzo presidente degli Stati Uniti, Thomas Jefferson (Shadwell, 1743 - Charlottesville, 1826) che aveva vissuto cinque anni in Francia, come plenipotenziario americano. Humboldt arrivò a Jefferson tramite il Segretario di Stato a cui aveva scritto "[...] dopo aver visto il grande spettacolo delle maestose Ande e la magnificenza del mondo fisico,



Figura 3 - Immanuel Kant (1768). Ritratto di J. G. Becker (1720-1782), particolare, olio su tela 46 × 59 cm, Schiller-Nationalmuseum, Marbach am Neckar - Germania [103].

Figure 3 - Immanuel Kant (1768). Portrait by J. G. Becker (1720-1782), detail, oil on canvas 46 × 59 cm, Schiller-Nationalmuseum, Marbach am Neckar - Germany [103].

vorrei godermi lo spettacolo di un popolo libero [...]” [32, p. 796]. Del rapporto fra Natura e Libertà Humboldt affermava:

- la Natura è il regno della Libertà; [15, p. 3];
- l'equilibrio della Natura è creato dalla diversità: gli elementi, dal più umile muschio ai più grandiosi alberi, hanno un ruolo e nel loro insieme compongono il tutto, di cui il genere umano è solo una piccola parte; [15; p. 5];
- la Natura in sé è una repubblica fondata sulla Libertà e la Politica deve prenderla a modello. [39]

Qui, sia pure implicitamente, ci dice anche quanto egli fosse contrario alla schiavitù che aveva già visto a Cuba, dove esplicitamente la dichiarò immorale, e che la ritrova anche negli Stati Uniti proprio in casa del democratico e liberale Jefferson, proprietario di schiavi utilizzati nelle piantagioni.

3. I seguaci di Humboldt

Dei molti seguaci di Humboldt ne citeremo soltanto due: uno scienziato e un letterato.

Il più famoso scienziato seguace di Humboldt è stato certamente Charles Darwin (Shrewsbury, 1809 - Londra, 1882), figura 4, che a 22 anni a bordo del brigantino *Beagle* aveva iniziato un viaggio di studio intorno al Mondo. Sulla nave aveva con sé molti libri di botanica e zoologia e il resoconto, in sette volumi, della spedizione in Sud America di Humboldt, intitolato *Personal narrative* [11], che per ammissione dello stesso Darwin era stata la molla che lo aveva spinto a compiere il viaggio come naturalista del *Beagle*.

L'opera di Humboldt, col suo strutturare un abbozzo di biogeografia accese in Darwin “*un ardente desiderio di contribuire alla nobile struttura della Scienza Naturale*”, come scriverà nell'*Autobiografia* (1876).

Darwin, inoltre, condivideva l'opinione espressa venti anni prima da Humboldt in *Quadri della Natura* [10] in cui giudicava in modo sprezzante chi sosteneva la fissità delle specie, mentre egli era convinto della *trasformazione graduale delle specie*.

Nella sua visione olistica della Natura Humboldt sosteneva che se la Terra cambiava, se la terraferma e il mare si muovevano, se le temperature aumentavano o diminuivano, allora anche tutti gli organismi *devono essere stati soggetti a varie alterazioni* [14, vol. I p. 20]. Se l'ambiente influenzava lo sviluppo degli organismi, allora gli studiosi dovevano indagare più da vicino i climi e gli habitat.

Ed è proprio finalizzato a ciò il forte impegno di Darwin che nel 1859 pubblicò *On the origin of species*, in cui la concezione evolutzionistica era espressa con piena maturità. L'opera, destinata a rivoluzionare la biologia, venne salutata come antesignana di un grandioso rinnovamento scientifico culturale da non pochi pensatori dell'epoca che resero la diffusione del darwinismo rapida ed estesa.



Figura 4 - Charles Darwin (ritratto giovanile, circa 1830) acquerello di G.Richmond (1809-1896) [104].

Figure 4 - Charles Darwin (youth portrait about, 1830) Water-colour by G.Richmond (1809-1896) [104].

Fra gli scrittori seguaci di Humboldt emerge certamente il più influente *scrittore della Natura* in America: Henry David Thoreau (Concord, 1817 - ivi, 1862), figura 5. Nel settembre del 1847 Thoreau ritornò a casa nella vicina città di Concord (Massachusetts) lasciando la capanna, da lui costruita a Walden Pond, dove aveva vissuto per due anni due mesi e due giorni, per studiare i cambiamenti stagionali dell'ambiente, intorno a un piccolo lago, in un bosco praticamente isolato dal resto del mondo.

Thoreau trasformò questi due anni di vita nei boschi in uno dei più famosi racconti di letteratura americana sulla Natura: *Walden ovvero Vita nei boschi* [35]. Il libro fu pubblicato nel 1854 dopo che Thoreau scoprì un nuovo mondo nel *Cosmos*, cioè nell'opera di Humboldt che più di tutte le altre unisce scienza e letteratura; la lettura di questo lavoro gli fornì la fiducia per intrecciare scienza e poesia.

La vita a Walden Pond si addiceva a Thoreau perché qui poteva perdersi nella lettura di un libro o restare a guardare un fiore, le lucciole, le foglie cadute, senza accorgersi di quanto accadeva intorno a lui. Thoreau era uno studioso della Natura che “voleva comprendere la formazione delle nuvole, ma anche un poeta rapito da quelle rosse montagne fluttuanti in cielo” [36, vol. III pp. 155-156]. Si chiedeva Thoreau che Scienza fosse quella che “arricchisce la conoscenza ma defrauda l'immaginazione” [36, vol. III pp. 155-156]. Egli seguiva alla lettera quanto scritto da Humboldt in *Cosmos*: “[...] la Natura va descritta con accuratezza scientifica, ma senza privarsi in tal modo del respiro vivificante dell'immaginazione [...]” [16, p. 74]; “la conoscenza non raffredda i sentimenti poiché sensi e intelletto sono connessi” [15, p. 21]. Ciò consentiva a Thoreau di intrecciare la scienza con l'immaginazione, il particolare con il tutto, il reale con il fantastico [39, p. 302].

Thoreau affermava “una descrizione del reale è la poesia più rara” [34, p. 329], e ancora “i fatti più belli e interessanti sono tanto più poesia” [36, vol. III p. 311] e inoltre “i fatti raccolti da un poeta sono infine considerati come i germi alati della verità” [36, vol. IV p. 116].

4. Cosmos

Fra i moltissimi scritti scientifico-filosofici di Humboldt quello che meglio esprime la sua visione olistica della natura e la necessità di studiarla con un approccio interdisciplinare è senza dubbio *Cosmos*, opera in cinque volumi realizzata fra il 1834 e il 1859. Questo lavoro ebbe grandissimo seguito e forgiò due generazioni di scienziati, artisti, scrittori e poeti.

Già nel primo volume di *Cosmos*, pubblicato nel 1845 [12], dopo dieci anni di gestazione, Humboldt parla dell'interazione perpetua fra l'aria, i venti, le correnti oceaniche, la quota e la densità della vegetazione.

A proposito di questo lavoro l'autore stesso dice: “il principale impulso che mi ha



Figura 5 - Henry David Thoreau (1856), dagherrotipo di B. D. Maxham (1821-1899), National Portrait Gallery, Washington. [105] *Figure 5 - Henry David Thoreau (1856), daguerreotype by B. D. Maxham (1821-1899), National Portrait Gallery, Washington [105].*

spinto è stata l'esigenza di comprendere i fenomeni fisici nelle loro connessioni generali, e rappresentare la natura come un unico grande complesso, mosso e animato da forze che provengono dall'interno" [28, p. 23 nota 17].

Humboldt spiega: [...] *Le vicissitudini della mia vita [...] m'obbligarono ad occuparmi [...] per diversi anni, di scienze speciali, di botanica, di geognosia, di chimica, di posizioni astronomiche e di magnetismo terrestre. M'apparecchiavo con tali studii ad effettuare con profitto viaggi lontani; più alto però n'era lo scopo. Desideravo di conoscere il mondo dei fenomeni e delle forze fisiche nella loro connesità e mutua influenza [...] persuaso intimamente che senza il desiderio d'acquistare una solida istruzione nelle parti speciali delle scienze naturali, ogni contemplazione della natura in grande, ogni tentativo di comprendere le leggi che compongono la fisica del mondo, non sarebbero che una vana e chimerica impresa [...]* [20, prefazione dell'autore].

In sintesi, nel primo volume di *Cosmos* troviamo un riassunto dei principali risultati dell'osservazione della natura, proposti in modo scientificamente obiettivo ma soprattutto interconnessi fra loro. Il modello esplicito di Humboldt è la *Naturalis Historia* di Plinio il Vecchio [26] da cui riprende anche l'ordine della descrizione: dall'immensamente grande all'immensamente piccolo, prescindendo da un ordine gerarchico interno alla natura e men che mai dall'esistenza di livelli diversi di *realizzazione* o di *consapevolezza* della materia, comune invece a tutte le concezioni naturalistiche del *romanticismo* [28, p. 42].

Tutti lessero *Cosmos* scienziati, politici, studenti, poeti, musicisti e tra questi Hector Berlioz (La Côte-Saint-André, 1803 - Parigi, 1869) letterato e compositore, *illuminista-romantico*, autore di *La damnation de Faust*, dal *Faust* di Goethe, che definì Humboldt *scrittore straordinario*.

Nel secondo volume [13], 1847, Humboldt conduceva i lettori in un viaggio della mente attraverso la storia umana, dalle civiltà antiche ai tempi moderni. Nessuna pubblicazione scientifica lo aveva mai fatto, nessuno scienziato aveva mai scritto sulla poesia, l'arte, i giardini, sull'agricoltura e la politica, sui sentimenti e sulle emozioni. Mentre il primo volume considerava il mondo esteriore, il secondo si concentrava sul mondo interiore. I filosofi si occupavano da millenni del dualismo fra mondo esterno e mondo interno, ovvero il mondo delle *cose in sé* e il mondo delle *cose come ci appaiono*. Secondo Kant la cosa in sé non poteva mai essere realmente conosciuta, mentre il mondo interno era sempre soggettivo.

Con Humboldt la geografia, da racconto del mondo, diventa lo sguardo dell'uomo sul mondo; il panorama (la vista del tutto, dal greco: *pân-*, tutto, *hórama*, vista) passa con lui dalla concezione *romantica* a quella *borgnese* (cioè *positivistica*). *Panorama* indica sia ciò che c'è sia quanto noi ci vediamo: significato e significante insieme. Il suo *Cosmos* mostra la natura come parte del panorama riferito allo sguardo dell'osservatore. Vale a dire che la natura che lui descrive è la natura vista dall'uomo nel tentativo di una comprensione che lo collochi come *superiore*. Lo scopo è mettere ordine in ciò che si vede e di ricomporlo in una *sintesi kantiana* che colga l'armonia del tutto. Per accedere alla vera scienza della natura è pertanto necessaria una rappresentazione che possa mediare tra la concretezza apparentemente disordinata della natura stessa e la fredda astrazione cartografica, che *commuova* l'animo no nel senso romantico ma in quello kantiano [28, p. 28] [3].

Nel dicembre 1850 Humboldt pubblicò la prima parte del terzo volume di *Cosmos* che concluse l'anno seguente [17]. Il terzo volume è più specialistico dei due precedenti, in esso si parla dei fenomeni cosmici, delle stelle, dei pianeti, della velocità della luce, ecc.

Mentre il terzo volume era in *corso d'opera* Humboldt iniziò a scrivere il quarto volume concentrandosi sulla Terra: geomagnetismo, vulcani, terremoti, ecc.

Oramai Humboldt era diventato così famoso che far visita all'anziano naturalista-letterato era diventato quasi un rito per i giovani studiosi. Humboldt amava incontrare i giovani, a prescindere che fossero scienziati, artisti o scrittori, e spesso li aiutava anche economicamente, incoraggiandoli a viaggiare verso gli angoli più remoti del pianeta. Molti visitatori restavano impressionati sia da quanto fosse vivace e attivo l'anziano signore sia dal flusso ininterrotto e straordinario delle sue conoscenze.

Nel dicembre 1857 venne pubblicato il quarto volume di *Cosmos* [19], ma Humboldt pensava già a un quinto volume dove approfondire la distribuzione delle piante sulla Terra, lavoro che spedì all'editore il 19 aprile 1859 [21]. Il 6 maggio di quell'anno cessò di vivere.

La mattina del funerale migliaia di persone parteciparono al corteo funebre. Era il più grande funerale privato mai visto a Berlino, erano presenti: professori universitari e membri dell'Accademia delle Scienze prussiana, soldati, diplomatici, artigiani, commercianti, negozianti, artisti, poeti, scrittori, attori, ecc. Il corteo si allungava per un chilometro e mezzo, la famiglia reale aspettava in cattedrale per l'estremo saluto.

5. La fama

Per qualche decennio la fama di Humboldt continuò a crescere. Più di venti anni dopo la sua morte Darwin lo definiva ancora "il più grande viaggiatore scienziato mai esistito" [2, p. 422].

Le sue concezioni della Natura penetrarono le diverse discipline, le arti come la letteratura, si infiltrarono nelle poesie di Walt Whitman (West Hills, 1819 - Camden, 1892) e nei romanzi di Jules Verne (Nantes, 1828 - Amiens, 1905) pertanto non c'è da stupirsi se, nel suo famoso *Ventimila leghe sotto i mari*, il Capitano Nemo possiede tutte le opere di Humboldt.

A metà del XX secolo il suo nome compare, insieme a quello del biologo paleontologo svizzero Louis Agassiz (Môtier, 1807 - Cambridge, USA, 1873), dello storico economista americano Alexander Del Mar (New York, 1836 - ivi, 1926) e dell'etnologo-archeologo tedesco Leo Frobenius (Brema, 1873 - Verbania, 1938), nel poema epico di Ezra Pound (Hailey, 1885 - Venezia, 1972) *I Cantos* [27], segnatamente nel *Canto LXXXIX*:

[...] *Out of von Humboldt: Agassiz, Del Mar and Frobenius*
The wrong way about it: despair. [...]

e nella Raccolta d'opere *Gesammelte Werke* [4] di Erich Fried (Vienna, 1921 - Baden-Baden, 1988) che in *Der Guacharo*, figura 6, dice:

[...] *Alexander von Humboldt lo ha chiamato l'uccello dell'olio, abitante della caverna, perché i suoi pulcini [col loro grasso] alimentano le lampade ad olio [...].*

Figura 6 - Guacharo (*Steatornis caripensis*, Humboldt, 1817), vive nelle grotte del Venezuela [106].

Figure 6 - *Guácharo* (*Steatornis caripensis*, Humboldt, 1817), lives in the caves of Venezuela [106].



Centotrenta anni dopo la sua morte lo scrittore colombiano Gabriel García Márquez (Aracataca, 1927 - Città del Messico, 2014) lo cita in *Cent'anni di solitudine* [6, p. 65]:

[...] *In realtà, l'unica cosa che riuscì a isolare nei borbottii catarrosi fu l'inesistente martellamento della parola equinozio, equinozio, equinozio, e il nome di Alexander von Humboldt* [...]

e lo fa rivivere nel racconto romanzato sugli ultimi giorni di Simón Bolívar (Caracas, 1783 - Santa Marta, 1830): *Il generale nel suo labirinto* [5].

Humboldt rese la scienza popolare e accessibile a tutti; tutti impararono: coltivatori, artigiani, studenti, insegnanti, artisti, musicisti, scienziati, politici. Nel mondo occidentale non c'era libro di testo o atlante che non fosse influenzato dalle idee di Humboldt.

La sua fama è stata tale da renderlo lo studioso a cui sono stati intestati più luoghi, animali e piante; ne facciamo un breve elenco [39, p. 8]:

- La *corrente oceanica di Humboldt* che costeggia Cile e Perù
- Montagne in America Latina, tra cui *Sierra Humboldt* in Messico e *Pico Humboldt* in Venezuela
- La città di *Humboldt*, nella provincia di Santa Fe, in Argentina
- Un fiume in Brasile
- Una baia in Colombia
- *Capo Humboldt* e *ghiacciaio Humboldt* in Groenlandia
- Catene montuose in Cina settentrionale, in Nuova Zelanda, in Nevada (USA), in Antartide
- Fiumi e cascate in Tasmania e in Nuova Zelanda
- Parchi in Germania
- *Rue Alexandre Humboldt* a Parigi
- Nel Nord America quattro contee e tredici città prendono il suo nome
- In California c'è *Humboldt Redwood State Park*
- Sia a Chicago sia a Buffalo c'è *Humboldt Park*
- Prendono il suo nome: trecento piante, tra cui un giglio (*Lilium humboldtii*), fig. 7, cento animali, tra cui un pinguino (*Spheniscus humboldti*), fig.8, e un calamaro di quasi due metri (*Dosidicus gigas* detto anche *Humboldt squid*).
- Diversi minerali hanno il suo nome, citiamo *humboldtii*.
- Troviamo Humboldt anche sulla Luna nel *mare Humboldtianum*.



Figura 7 - Giglio di Humboldt (*Lilium humboldtii*) [107].
Figure 7 - Humboldt's lily (*Lilium humboldtii*) [107].



Figura 8 - Pinguino di Humboldt (*Spheniscus humboldti*) [108].
Figure 8 - Humboldt penguin (*Spheniscus humboldti*) [108].

6. Il pensiero

Dopo aver visto i devastanti effetti ambientali delle piantagioni coloniali nella regione del lago Valencia in Venezuela, nel 1800 Humboldt, per primo, parlò di cambiamento climatico dannoso indotto dall'uomo. *“Quando le foreste vengono distrutte, come hanno fatto ovunque in America i coloni europei con incauta avventatezza, le sorgenti si prosciugano o diventano comunque meno abbondanti. I letti dei fiumi, restando asciutti, per parte dell'anno, si trasformano in torrenti, ogniqualevolta abbondanti piogge cadono sulle alture. Venendo a sparire dai fianchi delle montagne, con il sottobosco, zolle erbose e muschio, l'acqua che cade sotto forma di pioggia non è più impedita nel suo corso: e invece di far salire il livello dei fiumi con infiltrazioni progressive, durante i grandi diluvi scava solchi sui fianchi delle colline, trascina giù la terra non più trattenuta e provoca quelle inondazioni improvvise che devastano il paese”* [11, vol.IV pp. 143-144].

Humboldt sottolinea, in sintesi, l'importanza della foresta per la ritenzione idrica e la protezione del suolo e ammonisce l'uomo dicendo che il suo comportamento sta interferendo col clima, e ciò può avere sul futuro impatti imprevedibili.

Dell'abuso che l'uomo fa della Natura e dei guasti che in essa produce ne parla, diciotto secoli prima di Humboldt, anche Plinio il Vecchio in *Naturalis Historia* [26] dove dice: *“[...] Nella qual parte mi giova prima esser buon difensore della terra, madre di ogni cosa, [...]. Or perché ciò che la Natura produce di nocivo ne inette nell'animo odio inverso di lei, mentre noi abusiamo di ciò che essa produce, imputiamo a lei la colpa della nostra malvagità. Essa produce i veleni, ma chi li trovò, se non l'uomo? Gli uccelli e le fiere non fan più che difendersi e fuggire. E benché gli elefanti e gli uri arrotino e limino sugli alberi le lor corna, e il rinoceronte sui sassi; benché il cinghiale aguzzi or su gli uni, or su gli altri le arme de' suoi denti, ed ogni altro animale sappia prepararsi a nuocere; quale però di loro, da l'uomo in fuori, tinge le armi sue di veleno? [...] Noi avveleniamo sino a' fiumi, e agli elementi nella natura; e convertiamo in rovina infino all'aria, per la quale viviamo [...]. Confessiamo adunque la colpa esser tutta nostra, perché non contentandoci di quei veleni che nascono naturalmente, con le nostre mani ne facciamo degli altri in molti modi. [...]”*

Gli scritti di Humboldt rivelano un pensatore in anticipo sui tempi. Sua fu l'idea delle *zone climatiche* che si snodano attraverso il globo; nel suo viaggio sulle Ande, in particolare sul vulcano Chimborazo, figura 9, fu colpito dalle somiglianze, che si riscontrano in climi simili, nella vegetazione di siti i più possibili distanti fra loro. Per esempio, sulle Ande trovò un muschio che gli ricordava una specie proveniente dalle foreste della Germania settentrionale, lontane migliaia di chilometri. Sulle montagne di Caracas aveva osservato piante a forma di rododendro che assomigliavano a quelle che si trovano sulle Alpi svizzere. Più tardi in Messico vide pini, cipressi e querce simili a quelli che crescevano in Canada. A impressionarlo più di ogni altra cosa fu constatare che la vita è ovunque e agisce con *“forze organiche che lavorano senza sosta”* [14, vol. II p. 10], ma non era tanto interessato a scoprire nuovi eventi isolati quanto a connettere fra lo quelli già noti: *“I singoli fenomeni sono importanti solo nella loro relazione di insieme”* [15, p. 41]. In un suo disegno del monte Chimborazo, Humboldt descrive la Natura (*Naturgemälde*) molto efficacemente come una rete nella quale tutto è connesso. Le piante sono distribuite secondo le altitudini, dalle specie fungine che si sviluppano nascoste nel terreno ai licheni che crescono appena sotto la linea delle nevi perenni. Ai piedi della montagna c'è la zona tropicale delle palme e, più in alto, querce e cespugli a forma di felci, che preferiscono un clima più temperato.



Figura 9 - Monte Chimborazo (6310 m s.l.m.) è una montagna delle Ande localizzata nell'entroterra ecuadoriano. Benché non sia la montagna più alta del mondo, né delle Ande, in un certo senso lo è poiché essendo così vicina all'Equatore la sua vetta è alla massima distanza dal centro della Terra [109]. Nella sua spedizione su questa montagna Humboldt si era dotato di un armamentario strumentale fra i più sofisticati dell'epoca:

- due *barometri* per la misura della pressione atmosferica;
- un *ipsometro* per la misurazione della temperatura dell'ebollizione dell'acqua, da ricondurre alla quota;
- un *teodolite* per i rilievi geodetici;
- un sestante a specchio con orizzonte artificiale e un sestante tascabile;
- un *ago declinatorio* per determinare la forza del magnetismo terrestre;
- un *igrometro a capello* per misurare l'umidità dell'aria;
- un *eudiometro* per la misurazione della quantità di ossigeno nell'aria;
- una *bottiglia di Leida* per l'accumulo di cariche elettriche;
- un *cianometro* per il rilevamento della percentuale di azzurro nel colore del cielo;
- due *orologi parigini*, che non avevano più bisogno del pendolo, ma avevano dentro delle molle che vibravano ad intervalli regolari e che, se usati con perizia, non si discostavano dall'ora di Parigi. La loro indicazione, l'altezza del Sole sull'orizzonte e l'uso di specifiche tabelle, consentivano di determinare la Longitudine [9, 28].

Figure 9 - Chimborazo (6310 m m.s.l.) is a mountain of the Andes located in the Ecuadorian hinterland. Although it is not the highest mountain in the world, nor in the Andes, in a certain sense it is because being so close to the Equator, its summit is at the maximum distance from the center of the Earth. [109]. On his expedition to this mountain, Humboldt had equipped himself with some of the most sophisticated instrumental equipment of the time:

- *two barometers to measure atmospheric pressure;*
- *a hypsometer to measure temperature of the boiling water, to be traced back to altitude;*
- *a theodolite for geodetic surveys;*
- *a mirror sextant with artificial horizon and a pocket sextant;*
- *a dipping needle to determine the strength of terrestrial magnetism;*
- *a hair hygrometer to measure air humidity;*
- *an eudiometer to measure the amount of oxygen in the air;*
- *a Leyden jar for the accumulation of electrical charges;*
- *a cyanometer for detecting the percentage of blue in the color of the sky;*
- *two Parisian chronometers, which no longer needed the pendulum, but had springs inside that vibrated at regular intervals and which did not deviate from Paris time if used with skill. Their indication, the height of the Sun above the horizon and the use of specific tables, made it possible to determine the Longitude [9, 28].*

Ogni pianta è collocata sulla montagna esattamente dove Humboldt l'aveva trovata [9]. A sinistra e a destra della montagna dispose colonne contenenti informazioni e dettagli relativi a quanto raffigurato. Considerando una particolare altezza della montagna era possibile tracciare connessioni attraverso la tavola e la figura della montagna per saperne di più, per esempio, su temperatura, o umidità, o pressione atmosferica, nonché sulle specie di animali e piante che si potevano trovare alle diverse latitudini. Questa massa di informazioni poteva essere poi collegata alle altre grandi montagne del mondo, elencate in base alla loro altezza accanto alla sagoma del Chimborazo. [39]

In altre parole, Humboldt aveva una visione “[...] *fisiognomica del paesaggio naturale, come espressione di una profonda forza di organizzazione esercitata dall'ambiente e dalle sue caratteristiche fisiche e climatiche sugli esseri viventi (sicché i tipi delle associazioni vegetali tendono a convergere morfologicamente, al di là delle stesse diversità sistematiche delle specie coinvolte, in regioni distanti tra di loro, ma simili per condizioni)* [...]” [24].

È per questa sua visione che Humboldt ammoniva il genere umano che interferiva con le connessioni che la Natura stabiliva fra i vari elementi dell'ambiente. L'uomo non doveva modificare il mondo naturale a suo piacimento poiché ciò poteva portarlo a conseguenze catastrofiche.

Non sappiamo se il poeta inglese Francis Thompson (Preston, 1859 – Londra, 1907) sia stato ispirato dalla lettura diretta delle opere di Humboldt o di qualche suo seguace, ma è certamente humboldtiano il passo della poesia *The Mistress of Vision* (La signora della Visione) inserita nel volume *New Poems* [33] del 1897 che nei versi 151÷156 recita:

[...] *Tutte le cose da un immortale potere,
Vicino o lontano, segretamente
Si ricollegano le une alle altre,
Così che non puoi toccare un fiore
Senza turbare una stella.* [...]

Humboldt fu il primo a mettere in relazione colonialismo e distruzione dell'ambiente con la costruzione di dighe per fare gli invasi al servizio di monoculture; in particolare nella valle di Aragua in Venezuela, un tempo una delle regioni agricole più ricche, aveva incontrato popolazioni ridotte alla fame perché il terreno veniva ora sfruttato solo per la coltivazione dell'*Indigofera tinctoria*, figura 10, un arbusto da cui si ricavava l'indaco una tinta di colore blu intenso, molto richiesta all'estero ma prodotta così intensivamente da impoverire irreversibilmente il suolo.

Oppure a Cuba, spogliata delle sue foreste, si coltivava solo la canna da zucchero costringendo la popolazione a sfamarsi, con costi insostenibili, con prodotti di importazione.

Ma negli scritti di Humboldt affiora anche l'animo del letterato e del poeta, e fra dati e rilevamenti scientifici parla di come “*arcobaleni colorati risplendono, svaniscono, e riappaiono sulle grandi rapide dell'Orinoco illuminate dal Sole* [e come su di esse] *appaia*



Figura 10 - *Indigofera tinctoria*, dalla fermentazione delle sue foglie si otteneva l'indaco, un colorante blu intenso, oggi prodotto di sintesi. [110].

Figure 10 - Indigofera tinctoria, from the fermentation of its leaves, indigo was obtained, an intense blue dye, now a synthetic product. [110].

la Luna cinta da anelli colorati” [14, vol. I pp. 224 e 231], figura 11; commentando queste riflessioni con: “*ciò che parla all’anima sfugge alle nostre misurazioni*” [11, vol. IV p. 134].

Humboldt, come precedentemente detto, usa lo *stile visivo* in modo da stimolare l’immaginazione del lettore nella *osservazione del panorama*. Il suo *Saggio sulla geografia delle piante* (1807) [9], di cui donò una copia con dedica a Goethe, è il primo libro al mondo di ecologia (questo termine sarà coniato cinquant’anni più tardi), in esso si



Figura 11 - Le rapide di Maipures alla confluenza del Rio Tuparro nel grande Orinoco, Venezuela-Colombia [111].
Figure 11 - Maipures rapids at the confluence of the Rio Tuparro in the Orinoco river, Venezuela-Colombia [111].

afferma un concetto unitario ma diversificato dell’universo fisico, dove la Natura vivente e quella inorganica si corrispondono e determinano insieme la “personalità” dei vari ambienti naturali. Dicendo ciò Humboldt esercita una mediazione di profondo significato storico e concettuale tra le intuizioni goethiane e la scienza francese di fine Settecento, basata principalmente sul pensiero del fisico e chimico Antoine-Laurent de Lavoisier (Parigi, 1743 - ivi, 1794). In sintesi, l’opera di Humboldt contribuisce a rendere più stretti i legami fra le scienze della vita e le discipline inorganiche. Vivendo fra Parigi e Berlino, Humboldt può rendersi interprete, nell’ambiente scientifico tedesco, delle esigenze fatte maturare da Lavoisier nella scienza francese ed ereditate dalla generazione del naturalista Jean-Baptiste Lamarck (Bazentin-le-Petit, 1744 - Parigi, 1829), del biologo Georges Cuvier (Montbéliard, 1769 - Parigi, 1832) e del filosofo Auguste Comte (Montpellier, 1798 - Parigi, 1857) [1].

Anche nella sua attività didattica (svolta prevalentemente presso l’Accademia di Berlino, *Akademie der Wissenschaften* diretta da Wilhelm von Humboldt, Potsdam, 1767 - Tegel, 1835, fratello di Alexander) Humboldt svolse una autorevole mediazione fra scienza e cultura umanistica, convinto che l’Accademia, intesa come sede della ricerca pura avesse “*il compito di sottoporre il lavoro di ognuno al giudizio di tutti*” [1]. È presso l’Accademia che Humboldt, nel 1827, tiene un corso di Geografia Fisica per illustrare le osservazioni compiute durante un suo viaggio in Sud America (1799 - 1804). Il corso costituirà il nucleo di *Cosmos*, opera enciclopedica in cinque volumi (1834-1859) del sapere naturalistico.

Con Humboldt la fisica, in senso più ampio, e la biologia si sviluppano sempre più nella vita culturale prussiana e avviene, sia pure lentamente, il passaggio dell’università dalla fase metafisica a quella naturalistica, come nel 1893 scrisse il patologo Rudolf Virchow (Świdwin, 1821 - Berlino, 1902) [1].

Nelle lezioni tenute a Parigi nel 1827 - 28, che rappresentano l’illustrazione più ampia della geologia di tutta la Terra, Humboldt, nella polemica fra *netunisti* e *plutonisti*, dove prevalevano i secondi, offre uno spunto per superare le rigide posizioni plutoniste e ricondurre a un pensiero univoco anche i processi geologici.

Humboldt, con la sua opera, riuscì a collegare tutte le discipline in una visione unitaria del mondo dove natura organica e natura inorganica formano un sistema unico di forze attive

e dove tutti gli organismi della Terra sono legati come una famiglia che condivide la stessa “casa”. Ma nonostante la chiarezza di queste sue idee, non propose mai un termine o una locuzione per riassumerne il concetto. Ciò fu fatto da Ernst Haeckel (Potsdam, 1834 – Jena, 1919), figura 12, medico, filosofo e divulgatore le cui teorie erano frutto della fusione della *discendenza con modificazioni* di Charles Darwin, con la *teoria delle metamorfosi delle piante* di Goethe e col *trasformismo* di Jean-Baptiste Lamarck. Nel suo libro del 1866 E. Haeckel, *Generelle Morphologie der Organismen* [8], chiamò questa visione olistica humboldtiana *ecologia* dal termine greco *oikos* che significa casa e *logos studio*, ed afferma: “*per ecologia intendiamo l'intera scienza delle relazioni dell'organismo con l'ambiente circostante, dove possiamo includere, in senso lato, tutte le condizioni di esistenza*” [8, p.286].



Figura 12 - Ernst Heinrich Philipp August Haeckel (circa 1860). [112].
Figure 12 - Ernst Heinrich Philipp August Haeckel (about 1860). [112].

7. Conclusioni

Molto ancora si dovrebbe dire su Humboldt scienziato-viaggiatore, docente universitario, uomo politico, ecc., ma poco aggiungerei alla grandezza di quest'uomo che però, nonostante tutto, è andato perso nella nebbia della storia, rapidamente dimenticato dal mondo scientifico e più lentamente, ma inesorabilmente, da quello letterario. Humboldt fu uno degli ultimi intellettuali *eclettici* e morì in una epoca in cui le discipline scientifiche si andavano consolidando in campi sempre più delimitati e specialistici. Conseguentemente il suo approccio olistico fortemente interdisciplinare (un metodo scientifico che accanto ai dati concreti includeva arte, storia, poesia, politica) non godeva più di grandi simpatie.

Il ruolo di filosofo-naturalista è innegabile ma egli non scoprì né continenti né nuove leggi per la fisica e per questo fu “dimenticato” dal mondo della scienza; il suo modo di scrivere, troppo immaginifico, ripudiato dagli scienziati, risultò arcaico per i letterati.

Altra ragione per cui Humboldt è scomparso dalla memoria collettiva, almeno in Gran Bretagna e negli Stati Uniti è il sentimento anti-tedesco che si sviluppò con la prima guerra mondiale. Non sorprende che uno scienziato tedesco non fosse più popolare in questi due paesi dove non si suonava più la musica di Beethoven e di Bach, né si leggeva Goethe e Schiller e la lingua tedesca era stata eliminata dai *curricula* scolastici.

Successivamente alla Seconda guerra mondiale, con un minor numero di immigrati tedeschi e una maggiore cura nella loro integrazione, non si ripeté l'isteria antitedesca della Prima guerra mondiale, ma *ormai il danno era stato fatto* [25], l'opinione pubblica si era dimenticata di Humboldt, un tempo celebre come Cristoforo Colombo.

Ma al di là dell'oblio in cui era precipitato Humboldt, resta il principio da lui stabilito: la stessa distribuzione di piante la si può trovare sulle diverse montagne del mondo in base alla loro quota su queste. In definitiva Humboldt, aveva mostrato la Natura come un'unica forza con zone climatiche che corrispondevano fra loro al di là dei continenti; le piante, per lui, non erano da disporsi secondo categorie tassonomiche di appartenenze ma

andavano considerate in relazione al clima e all'ubicazione [14]. I limiti della vita vegetale e, sia pur meno marcatamente, animale sono rappresentati dalle basse temperature e dall'aridità. Tali estremi si trovano alle alte latitudini, per bilancio energetico annuo deficitario e alle alte quote, per il raffreddamento dell'aria con l'altezza e nelle zone desertiche, per la conformazione della circolazione generale dell'atmosfera. Fra questi casi estremi vi è una *moltitudine di zone climatiche* che sono caratterizzate dalla loro posizione geografica in conseguenza alla loro: *latitudine, idrologia, distanza dal mare, collocazione sulle coste in relazione alle maggiori correnti della circolazione oceanica*. A queste si aggiungono le modificazioni prodotte dall'uomo con l'agricoltura che altera in modo significativo la superficie terrestre (disboscamenti, dighe, ecc.); è allora chiaro che la semplice classificazione in relazione a: *latitudine, temperature e precipitazioni medie annue*, non può essere accettata per i complessi fenomeni della vita e in particolare di quella vegetale. Quest'ultima è governata da cicli regolati da ritmi temporali che hanno le loro leggi e al di fuori delle quali la loro vita non può sussistere. In conseguenza di ciò anche la ripartizione temporale dei parametri climatici, per una corretta classificazione fito-climatica, va presa in considerazione. In altre parole, la Natura non segue né il calendario astronomico, legato ai solstizi e agli equinozi, né quello meteorologico che data a partire dal primo giorno del mese in cui avvengono i succitati eventi astronomici.

Fin dalle prime classificazioni climatiche, in cui si cimentarono svariati autori, iniziate a fine Ottocento e proseguite fino alla Seconda guerra mondiale, non si tenne conto della lezione di Humboldt; bisogna arrivare al 1955 per ottenere, dall'agrometeorologo Fritz Schnelle (Halle, 1900 - Merzhausen, 1990, figura 13) nel suo lavoro *Pflanzen-Phänologie* [29], una visione più organica e articolata legata all'intuizione fenologica di Humboldt.

Oggi a 250 anni dalla nascita di Humboldt, visti i danni che nel frattempo l'uomo ha fatto interferendo con le cose della Natura, per ripristinare quei fili che in Natura collegano tutte le cose, è necessario riconsiderare il suo pensiero. Certamente altre menti *eclettiche* ci sono e ci saranno in futuro, ma con l'enorme e sempre più rapido sviluppo delle conoscenze scientifiche e tecnologiche non è pensabile che esse possano essere concentrate in un *nuovo Humboldt reale*, ma niente può o potrà impedirci di *costruirne uno virtuale* creando noi, ad arte, i legami

fra le cose, in altri termini creando connessioni interdisciplinari che estendano le possibilità di analisi del singolo specialista, intrecciando le sue conoscenze con quelle degli altri. Si tratta cioè di trovare il modo di applicare su scala globale ciò che su scale più piccole, ad esempio industriale, è stato ormai sperimentato con enorme successo. In *Italiani si rimane* [30] si legge che per creare l'impero di Apple “[...] *Steve Jobs* (San Francisco, 1955 - Palo Alto, 2011) *non si limitava a reclutare i migliori computer scientists, nei gruppi di lavoro di Apple inseriva: un esperto in scienze naturali, uno studioso di scienze umane, una persona che avesse senso artistico e un'altra che avesse studiato diritto [...]*”. Nella stessa pagina si dice anche che oltre alle molteplicità delle competenze è importante la “[...] *miscela umana. La differenza di età per cominciare: un trentenne intuisce qualcosa che a un sessantenne sfugge, e viceversa. La differenza di sesso. La varietà etnica e sociale [...]*” [30, p. 215].



Figura 13 - Fritz Schnelle [113].

Figure 13 - Fritz Schnelle [113].

In sintesi, la Natura è per Humboldt un complesso dinamico e unitario, all'interno del quale i fenomeni presentano caratteri coerenti e relazioni comuni, e sono regolati da leggi fisiche valide universalmente, ovunque si manifestino. Si tratta di una posizione *organicistica*, la quale presume che l'organismo possieda delle caratteristiche e delle peculiarità che derivano dall'integrazione e non dalla mera aggregazione delle singole componenti; in altre parole, nella sua interezza l'organismo va visto come qualche cosa di diverso e di più della addizione delle parti. L'ordine naturale viene così a somigliare ad un organismo complesso, simile al corpo umano, all'interno del quale ogni elemento può essere compreso solo in quanto partecipa e dipende dal tutto [28].

8. Bibliografia

- [1] AA.VV. (1977) - *Scienza e tecnica dalle origini al Novecento*, volume II, edizioni EST, editore Mondadori, Milano
- [2] Darwin C. (1911) - *The Life and Letters of Charles Darwin: Including an Autobiographical Chapter* vol.II D. Appleton and company, New York and London
- [3] Farinelli F. (2007) - *L'invenzione della terra*, Sellerio, Palermo
- [4] Fried E. (1993) - *Gesammelte Werke*, in vier Bänden, Verlag K. Wagenbach Berlin
- [5] García Márquez G. (1989) - *Il generale nel suo labirinto*, Mondadori Milano
- [6] García Márquez G. G. (2005) - *Cent'anni di solitudine*, Feltrinelli Editore, Milano
- [7] Goethe J.W. von (1997) - *Massime e riflessioni*, a cura di S. Giametta, Bur Rizzoli Milano
- [8] Haeckle E. (1866) - *Generelle Morphologie der Organismen: allgemeine Grundzüge der organischen Formen-Wissenschaft, mechanisch begründet durch die von Charles Darwin reformirte Descendenz-Theorie*. Verlag von G. Reimer, Berlin.
- [9] Humboldt A. von (1807) - *Ideen zu einer Geographie der pflanzen nebst einem naturgemälde der tropenländer*, F.G. Cotta, Tübingen
- [10] Humboldt A. von (1808) - *Ansichten der Natur: mit wissenschaftlichen Erläuterungen*, J.G. Cotta'sheb Buchhandlung, Tübingen
- [11] Humboldt A. von (1814-29) - *Personal Narrative of Travels to the Equinoctial of the New Continent during the years 1799-1804*, trad. H. M. Williams, London Longman, Hurst, Rees, Orme, Brown and John Murray
- [12] Humboldt A. von (1845) - *Kosmos. Entwurf einer physischen Weltbeschreibung*, Bd. 1 Verlag: Cotta, Stuttgart und Tübingen
- [13] Humboldt A. von (1847) - *Kosmos. Entwurf einer physischen Weltbeschreibung*, Bd. 2 Verlag: Cotta, Stuttgart und Tübingen
- [14] Humboldt A. von (1849) - *Aspects of nature in different lands and different climates; with scientific elucidations*, in two volumes, tr. E. Sabine, published by Longman, Brown, Green, and Longmans & J. Murray, London
- [15] Humboldt A. von (1849) - *Cosmos A Sketch of a Physical Description of the Universe* Vol. I, tr. E. J.L. Sabine, published by Longman, Brown, Green, and Longmans & J. Murray, London
- [16] Humboldt A. von (1849) - *Cosmos A Sketch of a Physical Description of the Universe* Vol. II, tr. E. J.L. Sabine, published by Longman, Brown, Green, and Longmans & J. Murray, London

- [17] Humboldt A. von (1851) - *Kosmos. Entwurf einer physischen Weltbeschreibung*, Bd. 3
Verlag: Cotta, Stuttgart und Tübingen
- [18] Humboldt A. von (1852) - *Cosmos A Sketch of a Physical Description of the Universe*
Vol. III, tr E. J.L. Sabine, published by Longman, Brown, Green, and Longmans &
J. Murray, London
- [19] Humboldt A. von (1858) - *Kosmos. Entwurf einer physischen Weltbeschreibung*, Bd. 4
Verlag: Cotta, Stuttgart und Tübingen
- [20] Humboldt A. von (1861) - *Cosmos Saggio di una descrizione fisica del Mondo* Vol. I,
tr. G. Vallini, ed. G. Grimaldo Venezia
- [21] Humboldt A. von (1862) - *Kosmos. Entwurf einer physischen Weltbeschreibung*, Bd. 5
Verlag: Cotta, Stuttgart
- [22] Kant I. (2004) - *Geografia fisica*, trad. A. Eckerlin, con prefazione di F. Farinelli,
Leading Edizioni, Bergamo, Riproduzione anastatica dell'edizione Silvestri 1807-1811
- [23] Kehlmann D. (2008) - *La misura del mondo* Feltrinelli, Milano
- [24] Mosio F. - *Alexander von Humboldt*, voce su Enciclopedia on-line Treccani
<http://www.treccani.it/enciclopedia/alexander-von-humboldt/> (05/07/18)
- [25] Nichols S. (2006) - *Why was Humboldt Forgotten in the United States?* Geographical
Review vol.96 n.3, *Humboldt in the Americas* pp.399-415
- [26] Plinio il Vecchio (1844) - *Naturalis Historia liber XVIII*; traduzione di M. Lodovico
Domenichi, Venezia
- [27] Pound E. (1957) - *Rock Drill de los cantares*, London, Faber and Faber
- [28] Repetto P. (2018) - *Humboldt controcorrente*, Altro novecento, n.9, Fondazione Luigi
Micheletti
- [29] Schnelle F. (1955) - *Pflanzen-Phänologie, Probleme der Bioklimatologie* Bd. 3,
Verlag Geest & Portig Leipzig.
- [30] Severgnini B. (2018) - *Italiani si rimane*. RCS, Milano
- [31] Sommerville M. (1834) - *On the Connexion of the Physical Sciences*, ed. J. Murray,
London
- [32] Terra H. de (1959) - *Alexander von Humboldt's Correspondence with Jefferson,
Madison, and Gallatin*, Proceedings of the American Philosophical Society, Vol. 103,
No. 6, pp.783-806 A
- [33] Thompson F. (1897) - *New Poems*, A. Constable and co., Westminster
- [34] Thoreau H. D. (1900) - *A week on the Concord and Merrimack rivers*, published by
T.Y. Crowell, New York
- [35] Thoreau H. D. (1970) - *Walden ovvero Vita nei boschi*, Mondadori, Milano.
- [36] Torrey B., Allen F. H. (editors) (1949) - *Journal of Henry D. Thoreau* in fourteen
volumes, ed. Houghton Mifflin, Boston
- [37] Whewell W. (1834) - *Review of On the Connexion of the Physical Sciences*, Quarterly
Review, 51, pp.58-61
- [38] Whewell W. (1840) - *The Philosophy of the Inductive Sciences*, John W. Parker, West
Strand, London
- [39] Wulf A. (2017) - *L'invenzione della natura. Le avventure di Alexander Von Humboldt,
l'eroe perduto della scienza*, LUISS University Press.

Sitography

- [101] (13-02-20)  <https://commons.wikimedia.org/wiki/File:AvHumboldt.jpg>
- [102] (13-02-20)  [https://commons.wikimedia.org/wiki/File:Goethe_\(Stieler_1828\).jpg](https://commons.wikimedia.org/wiki/File:Goethe_(Stieler_1828).jpg)
- [103] (13-02-20)  https://commons.wikimedia.org/wiki/File:Kant_gemaelde_3.jpg
- [104] (13-02-20)  https://commons.wikimedia.org/wiki/File:Charles_Darwin_by_G._Richmond.jpg
- [105] (13-02-20)  https://commons.wikimedia.org/wiki/File:Henry_David_Thoreau.jpg
- [106] (24-02-20)  https://commons.wikimedia.org/wiki/File:Steatornis_caripensis_by_anagoria.JPG
- [107] (10-02-20)  https://commons.wikimedia.org/wiki/File:Lilium_humboldtii2.jpg
- [108] (10-02-20) <https://www.sapere.it/.imaging/default/dam/animali/uccelli/Spheniscus-humboldtii/jcr:content.jpg>
- [109] (10-02-20) <https://www.cute-calendar.com/event/chimborazo-day/38336.html>
Copyright: Patrick Gijsbers, license: istockphoto.com
- [110] (10-02-20)  https://fr.wikipedia.org/wiki/Fichier:Indigofera_tinctoria_id_plt_Paris.jpg
- [111] (10-02-20) <https://carosar19.wordpress.com/2012/12/13/raudales-de-maypures-vichada/>
- [112] (13-02-20)  https://commons.wikimedia.org/wiki/File:Ernst_Haeckel_1860.jpg
- [113] (08-03-20)  https://commons.wikimedia.org/wiki/File:Fritz_Schnelle.jpg

SESSION

**UNDERWATER AND
COASTAL CULTURAL HERITAGE**

Chairman: Marinella Pasquinucci
University of Pisa

UNDERWATER AND COASTAL CULTURAL HERITAGE

The session “*Underwater and coastal cultural Heritage*”, a “new entry” in the IBE Meetings, aims to study several aspects of the tangible and intangible cultural heritage linked to the coastal districts and related seabeds, focusing on a broad spectrum of archaeological, historical, geographical, landscape issues to be investigated in an interdisciplinary and diachronic perspective.

The papers here published provide relevant insights about various aspects of heritage studies in several coastal districts. As for the subject matters, archaeology, landscape archaeology and architectural heritage are widely represented.

Since it is impossible to sum the complex contents of all the contributions in this short Introduction, I focus only on a few main *insights* from each paper, in order to intrigue the readers’ curiosity.

Patrizia Tartara in “*Along the Caeretan coast and forward on*” examines the district north-west of Rome, which was in large part controlled by the Etruscan metropolis Caere. Special attention is paid to the coastal strip from Ostia/Fiumicino to Civitavecchia, which includes the three ancient ports *Punicum* (Santa Marinella), *Pyrgi* (Santa Severa) and *Graviscae* (Porto Clementino). As for the applied methodology, the archeological and topographical study of the ancient sites has been integrated with the study of both historical (1930 glass slides 13x18 by the *Istituto Geografico Militare* –IGM– Florence) and recent aerial photographs. Monitoring flights operated by the Pratica di Mare Carabinieri Helicopter Group in collaboration with the General Headquarter of the Carabinieri, *Nucleo Tutela Patrimonio Culturale* were included. The analysis of old and recent photographs, with additional monitoring flights over areas at risk, is an excellent methodology to get an historical perspective of the studied territory and a tool to enhance the protection of the cultural heritage, in particular of the few preserved areas of historical landscape.

In “*Pyrgi: analysis of possible climatic effects on a coastal archaeological site*” Virginia Coletta, Fernanda Prestileo, Paolo Allasia, Alessandra Bonazza, Alessandro Ciarravano, Stefano Federico, Davide Notti, Rosa Claudia Torcasio, Mattia Crespi and Stefano Dietrich present an interdisciplinary study focused on Pyrgi (Santa Severa, Rome), an Etruscan and Roman harbour site.

Frequent flooding affects the relevant archeological area, limits the accessibility and delays the archaeological excavations. In order to investigate the hazards to which the site is exposed the authors apply an interdisciplinary approach that integrates meteorological datasets, hydrogeological investigations and the study of site images at different scales.

As stressed by the authors, the applied methodology can be extended to any other site at risk of flood damage, permanent submersion, erosion and absorption of saltwater both undermining the fragile balance of the archaeological structures and delaying archaeological research or preservation works. Further important progress of the study is announced.

In “*San Cataldo (Lecce, Italy): the Historical Evolution of the coastal landscape*” Ivan Ferrari and Aurora Quarta analyse the port site San Cataldo and its territory, located

east of Lecce (Puglia), in a multidisciplinary and long term perspective. In antiquity and in the Middle Ages San Cataldo touched by important maritime routes connecting the opposite shores of the Adriatic Sea.

In the frame of the multidisciplinary project “Portus Lupiae” run by the University of Salento Ancient Topography and Photogrammetry Laboratory (LabTAF), the authors study the San Cataldo coastal landscape, heritage, port structures, infrastructures and urbanization process from antiquity to the present. They highlight the close links between the San Cataldo coastal landscape evolution and the economical and social history of Lecce and underline that in the second half of the 20th Century a new tourist vocation replaced the traditional commercial one, causing the overbuilding that characterises the coast today.

In “*Understanding the settlement dynamics of the Ionian coastal area of Salento (Puglia, Southern Italy): the contribution of new archaeological data from the fortified Messapian centre at Li Schiavoni*” Giovanna Cera focuses on the ancient settlement system in the coastal district of South Puglia, from Taranto to Santa Maria di Leuca, between the Archaic and the Hellenistic periods. Thanks to their strategic locations in elevated fortified areas, not far from the coastal strip dotted with landing places (ports and mooring areas), these sites controlled both the access to the sea and the immediate hinterland.

In particular, the fortified small Messapian centre Li Schiavoni developed during the 6th Century BC on a large plateau about four km inland from present Porto Cesareo and dominated a vast segment of the Ionian coastline. New archaeological data from the settlement is being examined, including evidence of the strict connections between this small Messapian centre and the Salento Ionian coast touched by maritime trade networks. The proximity to a series of promontories alternating with naturally protected stretches of coastline suitable for mooring, and the close proximity to the route network linking the coasts of South Puglia with the hinterland are proposed as possible factors for the emergence of the Messapian settlement.

Fabio Fabrizio presents the contribution “*Il Parco archeologico di Saturo (Leporano- TA). Millenni di storia, decenni di incuria*”. The paper focuses on the ancient port site Satyrion, located on the Puglia Ionian Coast in a naturally favorable position and inhabited from antiquity to the Middle Ages. The author *provides an overview* of the significant archaeological evidence and of the actions implemented for the enhancement of the local archaeological park since 1997.

In “*Evolution of the coastal landscape in Eastern Veneto: new data from preventive archaeology*” Alessandro Pellegrini and Alessandro Asta present a recent study of the Caorle area (Province of Venice). Aim of the research to identify the potential archaeological risk connected with the construction of new coastal protection works against erosion processes. The authors assemble legacy and new archaeological data (the latter resulting from the MiBACT information system RAPTOR- www.raptor.beniculturali.it and from the Soprintendenza archives) in a QGIS database, in order to create thematic maps useful for the interpretation of the context. Numerous submerged sites are also taken into account. The study of several historical maps preserved in the Venetian archives and of remote sensing images provides a major contribution to the research. The dataset has been enriched with the aim of protecting the archaeological heritage and, possibly, produce new predictive models applied to archaeological researches and landscape management.

Maria Carla de Francesco, Mauro Zappalorto, Diana de Francesco, Massimo Mangifesta, Angela Faraone, Maurizio Paluzzi, Claudia Minciarelli, Giulio Tatasciore e Andrea R. Natale contributed to the session with the paper “*Archaeological findings of ancient harbor in the pilot site of INTERREG ADRION APPRODI Project in Ortona (CH, Abruzzo), Central Adriatic Sea*”.

Aim of the project is the development of cultural tourism in the Ortona area by enhancing the naturalistic, historical and archaeological resources. An archeological Museum at Ortona is also proposed. Geological and archaeological investigations, including underwater surveys, were conducted in order to map the main geologic, naturalistic, archaeological and cultural sites in the local marine environment and create a descriptive underwater itinerary of the identified areas. Furthermore, the main maritime routes have been reconstructed with the creation of a photographic and video catalog. The work is in progress.

Laura Montioni, Andrea Del Corona, Isabella Palano, Francesca Pichi, Matteo Scamporrino present the contribution “*Evaluation and monitoring of the Livorno’s Fossi system*”.

The authors explain why and how the Livorno system of ditches and canals (“Fossi”) is linked to the history and growth of the city and characterizes the urban landscape. Nowadays the canals are moorings for boats and host nautical circles. The Northern Tyrrhenian Sea AdSP decided to start a project focused on the Livorno's Fossi system in order to collect the most reliable data concerning the extent of the pleasure craft, the status of the canals, the provided services, the general safety, etc. A specific methodology has been created in order to define, support and quantify the displacement of vessels that negatively affect safety, accessibility and the landscape of Livorno's Fossi system through a multi-criteria assessment of scenarios.

In “*Another Sicily, tuna-fishing structures and landscape: a diachronic and contemporary photographic journey along the Sicilian western coast*” Mauro Fontana presents his reflections on the Sicilian western coast landscapes based in large part on a photographic analysis. He focuses on the “tonnare” as architectural heritage and physical expression of the tradition of the tuna fishing. The author compares a photographic reportage taken by Ernesto Scevoli in 1986-1987 and the photos taken by himself in March 2018 and concludes that the examined Sicilian coastal landscape has undergone substantial changes which should be investigated in order to recover the coast characteristics and carry out targeted actions of preservation and enhancement of the architectural and cultural heritage.

The author highlights the importance of photography as an instrument “to discover, know, represent and understand reality”, in a continuous dialogue between natural and built environment.

Ricardo Martín, Víctor Yepes and Alejandro Grindlay present the paper “*Discovering the marina’s cultural heritage and cultural landscape*”. They define marinas as recreational boat facilities serving pleasure craft and reflect on the concepts of landscape, cultural landscape and cultural heritage landscape, port cultural heritage and landscape approach to marinas. Since several marinas are located in old fishing ports or share the port space with fishing or industrial activities, the longtime history of most ports is underlined as well as the complex approach to heritage matters in port areas.

In “*Coastal heritage and territorial signs*” Antonietta Ivona reflects on the coastal districts as “cultural transmission areas”, where people, goods and ideas coming from outside are integrated with the local ones. She focuses on the related cultural heritage, more precisely on the lighthouses and other coastal structures decommissioned by the State and reflects on the conservation path of such buildings. The author underlines that the conservation and reuse of these cultural resources is to be planned with specific attention to the historical-cultural values that shaped them over time, in order to re-include those structures in the economic and social life of the host community. The lighthouses in Croatia, Scotland, Maine, New England recently turned into flagship hotels are taken into account to demonstrate that they suffered no loss of cultural or economic value thanks to the proper evaluation of their cultural characteristics in the coastal landscapes and the strategies applied to the conservation process and subsequent management.

Marinella Pasquinucci

University of Pisa

Full Professor 2001-2012

Email pasquinnccimarinella@gmail.com

UNDERSTANDING THE SETTLEMENT DYNAMICS OF THE IONIAN COASTAL AREA OF SALENTO (PUGLIA, SOUTHERN ITALY): THE CONTRIBUTION OF NEW ARCHEOLOGICAL DATA FROM THE FORTIFIED MESSAPIAN CENTRE AT LI SCHIAVONI

Giovanna Cera

University of Salento – Department of Cultural Heritage, via D. Birago 64 – 73100 Lecce (Italy)
phone +39 0832 295685, e-mail: giovanna.cera@unisalento.it

Abstract – This paper aims to explore some aspects related to the settlement system on the Ionian coast of the Salento (Puglia, Southern Italy) - particularly in the time frame between the Archaic and Hellenistic periods - thanks to the special focus on the new archaeological data from the small fortified centre at Li Schiavoni.

The Salento coastline on the Ionian Sea, from Taranto as far as Santa Maria di Leuca, constitutes a rich vein of archaeological sites and is particularly renowned for the presence of a highly diversified series of settlements both on the coast itself and a just barely inland. These settlements developed in locations favourable to a range of human activities and in strategic positions for controlling both access to the sea and the immediate inland area.



Figure 1 - Oblique aerial photograph of the fortified Messapian centre at Li Schiavoni (Puglia, Southern Italy); in the background the Ionian coast.

Among these early communities is the small Messapian settlement located in the Li Schiavoni area, which developed over the course of the VI century BC on a large elevated plateau, dominating a wide stretch of the Ionian coastline, about four km inland from the modern town of Porto Cesareo (figg. 1-2). Extending over approximately three hectares, the settlement was protected by walls forming a roughly elliptical shape, about 650 m in length, as well as a ditch on the eastern side¹.



Figure 2 - Location of the fortified Messapian centre at Li Schiavoni (Nardò, Lecce, Puglia, Southern Italy).

In addition to the walls and the ditch, the defensive nature of this hilltop fort is revealed above all the choice of location, naturally protected by the elevated position, enabling occupation and control of the surrounding area as well as the coastline below, in direct relationship with the latter (fig. 2).

On-site stratigraphic studies, begun in 2016², have documented the building features and construction phases of the ancient walls, which date back to the VI century BC. These are formed by two facing walls constructed in large irregularly shaped limestone blocks, erected directly onto the rock base (or in some parts on a bed of stone chippings to

¹ For further details on the site and excavation findings: [11]; [12]; [13].

² The ongoing research is being carried out under the patronage of the SABAP Superintendent's Office for the provinces of Brindisi, Lecce and Taranto (prot. n. 4810 del 10-5-2016; prot. n. 10420 del 4-4-2017; prot. n. 8898 del 28-3-2018; prot. n. 13765 del 15-5-2019) and financed by Nardò town council and Salento University.

make the base more even) and were roughly 3,50 m thick. The space between the two walls was then filled with small and medium sized stones (fig. 3).

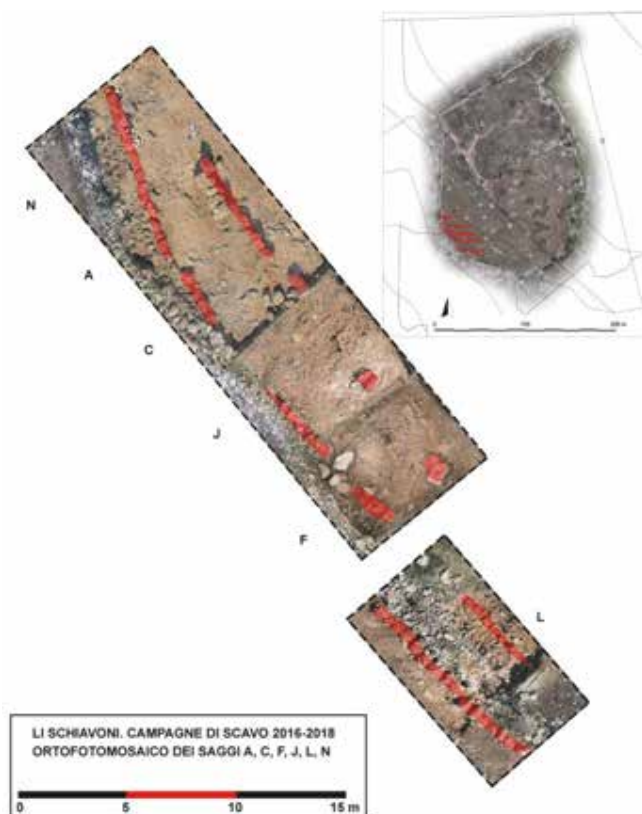

Figure 3 - The fortified Messapian centre at Li Schiavoni; in evidence the remains of the ancient walls, documented by the excavations.

The archaeological findings have uncovered some interesting data regarding the internal organisation of the settlement in archaic times, including both living spaces and small burial sites, alternating with open areas, similar to other Messapian settlements on the Salento region. The remains of a former home have been found in the south central area of the plateau. These comprise one room used as a kitchen and pantry, with a ceramic fireplace and a series of large food containers in hand turned pottery and another adjacent room, most likely originally covered by a canopy, with a cistern for gathering rain water, constructed inside a natural cavity in the living rock³.

³ [13].

On the outer edges of the area, various fragmentary items have been discovered - unfortunately out of context and all jumbled – linked to the presence of burial sites (blocks and slabs of local Leccese stone and tufo, fragments of grave goods) already brought to light in illegal diggings. In any case the quantity of pottery imported from Greece and Greek colonies is significant, clearly witnessing the participation of this small centre in the trading networks gravitating along the Salento Ionian coast.

In fact we cannot exclude this proximity to a series of promontories alternating with naturally protected stretches of coastline (Torre Chianca, Scala di Furno, Porto Cesareo, la Strea) and suitable for mooring, as a possible premise for the original emergence of the Li Schiavoni settlement. In fact, this small landing stage⁴, connected to the Scala di Furno sanctuary near Porto Cesareo⁵, could have played an important role in the exchange and redistribution of goods, establishing a direct link with the Li Schiavoni settlement. The latter undoubtedly benefitted from the favourable location, close to slightly inland routes in the direction of Capo di Leuca and those crossing the ‘isthmus’ to the Adriatic shore (San Cataldo)⁶.



Figure 4 - The Salento peninsula (Puglia, Southern Italy); in evidence the Messapian settlements mentioned in the text.

⁴ [43], p. 259.

⁵ [43], pp. 258-259; [8], 291; [33], pp. 90-91; [42].

⁶ [47], pp. 58-59, 71.

This close link between an elevated fortified area, just inland from the shore with one or more landing places (often connected to places of worship) enabling seafaring activities, is a recurring settlement model in Messapia and well documented in other sites along the Ionian coast⁷ (fig. 4). An example is the system linking the inland town of Nardò (an active centre from the archaic period onwards)⁸, with the port of Santa Caterina⁹ and the nearby Grotta di Capelvenere sanctuary (late VI – early V; late IV – early III centuries BC)¹⁰. Further south still we find the community of Alezio¹¹, which controlled the port of Gallipoli, and the vast city of Ugento¹², linked to the port of Torre San Giovanni¹³. On the southern tip of the coast is the settlement of Vereto¹⁴, connected to the harbour of Torre San Gregorio¹⁵ and perhaps even to the sanctuary of Grotta Porcinara (Leuca)¹⁶.

Other fortified sites controlling the Ionian coastline also emerge in this phase, such as Li Castelli¹⁷, near Manduria, where we can most probably identify the last Messapian stronghold just before Taranto territorial jurisdiction limits. It is surely not a coincidence that near this demarcation line the defence system becomes more intricate with the presence of fortified centres – of which unfortunately little is known – such as Monte Masciulo (Maruggio) (VI – IV centuries B.C.) where the remains of a lookout tower¹⁸, have been identified, Monacizzo and Monte Sant’Elia (Roccaforzata), all local Iron Age villages which later became fortified Greek colonies¹⁹.

The settlement which displays the most similar characteristics to our Li Schiavoni site – in particular the immediate inland location and the modest extension of the village itself – is the I Fani site near Salve, in the southern tip of the Salento peninsula. Here, a modestly sized settlement (approximately three hectares) developed on an elevated site, barely in from the coast and surrounded by an elliptical circuit wall built in large irregular blocks of stone (with a perimeter of 650 m)²⁰. Another element common to these two sites is the fact that both register a cessation phase about halfway through the VI century B.C. At the Li Schiavoni site the lack of pottery items from timeframes successive to the V century B.C. has been revealed both by surface research and stratigraphic investigation. This data is in line with documentation from other Messapian settlements also experiencing phases of abandonment and decline²¹, at this time, due to conflict with Taranto²². It is furthermore

⁷ [8], pp. 287-288, 306.

⁸ [32].

⁹ [16], p. 449 e fig. 27; [32], pp. 213-220; [31], pp. 124, 126.

¹⁰ [33], p. 81 n. 33, with bibliography.

¹¹ [22]; [21], pp. 143-146.

¹² [29].

¹³ [14], p. 564; [16], p. 449 e fig. 26; [31], p. 124.

¹⁴ [40]; [41].

¹⁵ A bustling centre from early Hellenistic times onwards yet a fully equipped port only from the late Republican era (II century B.C.): [7], mostly pp. 140-142; [8], pp. 30, 278-285; [31], p. 124.

¹⁶ [33], pp. 68-71 n. 21, with bibliography.

¹⁷ [1]; articles by A. ALESSIO, F. GUARINI e L. LEPORE, in [26]; [19].

¹⁸ [18]; [4], p. 368; [2], pp. 90-92. References in [35], p. 203.

¹⁹ About Sant’Elia: [4], p. 368; [2], pp. 90-92. About Monacizzo: [45], above all, p. 33 ss.

²⁰ [20]; [39].

²¹ See, for example, the sites of Cavallino ([17], pp. 42-43), of San Vito dei Normanni ([44], p. 322), the shrines of Oria, Monte Papalucio ([34], pp. 59-60) and Porto Cesareo, Scala di Furno ([33], p. 91).

²² [16], pp. 435-437, 439; [28], pp. 44-45.

significant that simultaneously, we witness the decline of the sanctuary area at Scala di Furno, a sign of a general crisis in the area leading to the abandonment of these minor centres along the coast.

From this moment onwards the Li Schiavoni area appears completely abandoned, however not definitively. Excavations conducted along the walls have documented rebuilding and reinforcement operations, implemented in a successive phase (fig. 5). The construction features of this second phase, which strengthen and notably widen the thickness of the oldest walls (now 6.7 m circa), imply a great sense of urgency in completing the reconstruction. A huge amount of earth and recycled building materials (mainly roof tiles, as well as large limestone blocks and slabs of tufo), evidently recovered from abandoned homes inside the walls, is amassed to reinforce the original fortifications, at this stage partly collapsed and ineffective. Likewise, an obvious need to work quickly and save on expense is clear from the way the support wall is built in local limestone blocks, easily found on the site and unfinished, laid directly on the ground with no foundation trench.

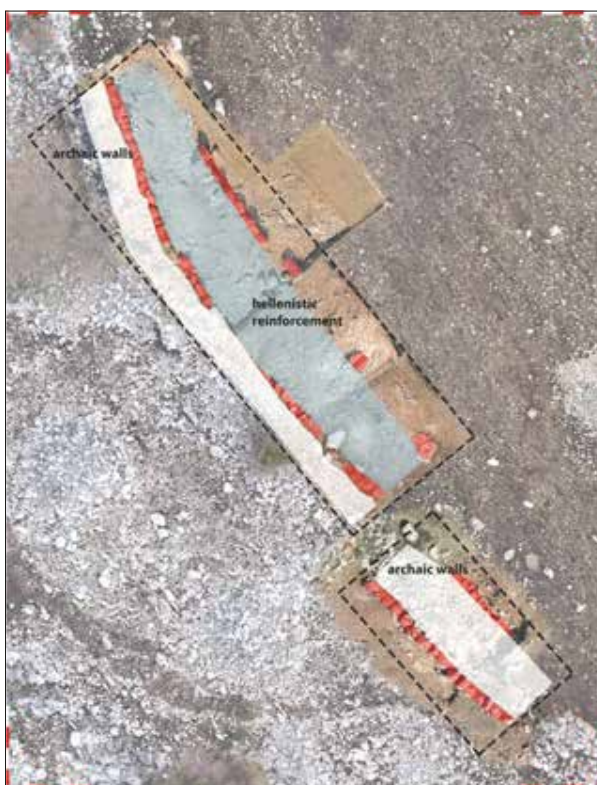

Figure 5 - The fortified Messapian centre at Li Schiavoni; in evidence the remains of the archaic walls and the Hellenistic reinforcement

Materials recovered from levels associated with the infill of the walls indicate a time frame of between the end of the IV and the first half of the III century as *terminus post quem* for this restoration. Despite the difficulties in proposing a more accurate date, it does not seem incautious to see a connection between these operations and the threat represented by the *bellum sallentinum* between Messapians and Romans, although we cannot exclude links with later events such as the war with Hannibal²³ or even strictly local conflict situations.

It must be stressed that the reinforcement of the walls is not accompanied by a repopulation of the site, as only sporadic and isolated forms of human occupation can be recognised throughout the IV-III centuries B.C. However, we can assume that, thanks to the reinforcing, the Li Schiavoni fortifications offered a safe haven for local inhabitants, able to find refuge there in moments of greatest danger. In a settlement context and very different conditions to those in which the site developed originally, the centre partially recovers its role as a lookout station monitoring the surrounding coastline and inland areas.

A very different situation characterises, in contrast, other coastal and inland centres on the Ionian shore, displaying full efficiency in the IV-III centuries BC. It appears that in this very same phase some portal towns, already thriving in archaic times, are endowed with walls or ditches, as documented for example in Santa Caterina, the port of Nardò, and further south, at Torre San Giovanni²⁴, Ugento harbour. In these centres we find fortifications displaying notable commitment, implying the availability of abundant economic resources only partly linked to genuine defence issues and evoking symbolic values of territorial control and collective representation.

In the more northern part of the Ionian coast the inland centre of Li Castelli is enlarged and reinforced by a new circle of walls²⁵, while further west, again immediately inland from the sea, the watchtower of Monte Asculio appears to be still in use and a possibly fortified settlement springs up close to the harbour, and to the sanctuary in the Torre Ovo²⁶ inlet.

With regard to Li Schiavoni however, it seems that, not long after the rapid reinforcement of the walls, the centre is completely abandoned once again. This is not by any means an isolated example, but part of a more general moment of deconstruction and/or abandonment common to many Messapian settlements in the second half of the III century, following the conquest of the entire region by the Romans and the war with Hannibal.

Nonetheless, in the second half of the II century a limited and partial reoccupation of the Li Schiavoni site takes place. In the northern section of the archaeological centre a consistent quantity of pottery shards (1500 mq)²⁷, has emerged, to be attributed to the presence of a vast rural settlement, in use up until late antiquity.

In this same timeframe, current documentation implies a later reoccupation of the coast during a phase of greater political stability, where previously active ports (Torre

²³ We know from historical sources that some Messapian settlements on the Ionian coast switched their support to Hannibal between 213 and 209 B.C.: Liv. XXII, 61, 11-12 (*Uxentum*); XXV, 1, 1; XXV, 22, 14; XXVII, 15, 4 (Manduria). On episodes from the second Punic War in Salento: [25], p. 58 ss.; [24], p. 157 ss.

²⁴ About Santa Caterina and Torre San Giovanni see notes 9 and 13.

²⁵ [19], pp. 318-319.

²⁶ [36]; [38]; [2], pp. 98-99; [31], p. 126.

²⁷ [11], p. 85 nota 24 e fig. 15.

Ovo²⁸, possibly the site of a wool dying plant²⁹, Santa Caterina, Torre San Giovanni, Torre San Gennaro) develop new trading dynamics, as attested also by numerous shipwrecks found along the coast³⁰. Besides these sites, new coastal settlements also develop, frequently linked to natural harbours, with activities based on fishing and fish products (Torre Chianca, near Porto Cesareo³¹, Santa Maria al Bagno³² and Palude del Capitano near Nardò³³).

References

- [1] ALESSIO A. (1991) - s.v. *Li Castelli*, BTCGI IX, Pisa-Roma, 19-23.
- [2] ALESSIO A. (2001) - *L'area a SE di Taranto*, Nuovi documenti dai territori tarantini, Atti del XLI Convegno di Studi sulla Magna Grecia (Taranto), 87-113.
- [3] ALESSIO A. (2018) - *Esempi di romanizzazione lungo la costa ionica del Salento*, G. LEPORE, C. GHIATTI (a cura di), La romanizzazione dell'Italia ionica. Aspetti e problemi, Atti del Meeting (Firenze 2014), Roma 2018, 89-98.
- [4] ALESSIO A., GUZZO P.G. (1989-1990) - *Santuari e fattorie ad est di Taranto. Elementi archeologici per un modello di interpretazione*, in *Anathema*. Regime delle offerte votive ed economia dei santuari nel mediterraneo antico, Atti del Convegno (Roma 1989), Scienze dell'Antichità 3-4, 363-396.
- [5] ALESSIO A., ZACCARIA A. (1997) - *Nuove ricerche sul relitto di San Pietro in Bevagna (Manduria-Taranto)*, Atti del Convegno Internazionale di Archeologia Subacquea (Anzio 1996), Bari, 211-244.
- [6] ALFONSO C. ET ALII (2012) - *Ancient coastal landscape of the marine protected area of Porto Cesareo (Lecce, Italy): recent research*, International Journal of the Society for Underwater Technology 30, n. 4, 207-215.
- [7] AURIEMMA R. (1998) - *Archeologia della costa salentina: l'approdo di Torre S. Gregorio*, StAnt 11, 127-148.

²⁸ Structural elements initially considered part of a harbour (docks and a pier) ([36], pp. 80-83) are now believed to be the remains of homes, in view of their position relative to the original coastline ([2], pp. 98-99). For other findings cf. see [3], p. 92.

²⁹ [36], p. 83

³⁰ Near the coast at San Pietro in Bevagna a cargo from a Roman ship (mid III century A.D.) carrying 23 marble tombs has been found ([5]). In the area of Torre Chianca there are five columns in cipollino marble, from another Roman ship cargo (late II-early III century AD) ([46]; [8], 2, p. 13; [9], p. 543 nota 9). From the waters in Porto Cesareo the wellknown green basalt statue of the Egyptian divinity Thot emerged (VI century BC) ([37]), indicative of the Roman trade in Egyptian sculptures ([27]). Under the water near Punta dell'Aspide (Santa Caterina), a ship carrying late Greco-Italian amphora from the II century BC was discovered wrecked off the coast ([8], 2, pp. 14-18; [3], p. 92).

³¹ At the level of the Torre Chianca promontory a settlement has been identified thanks to numerous remains of buildings and burial places; the remarkable concentration of mollusc shells found suggested the presence of a workshop producing purple dye ([46], pp. 74-75 e fig. 9; [43], p. 259; [31], p. 126; [9], p. 543), a theory recently rejected (since the shells are very small) in favour of more generic activities linked to fishing and fish products ([6], p. 210).

³² Very likely a port, with vestiges of buildings, tombs and streets from late Imperial times; identified with the *Emporium Nauna* mentioned in the inscription *CIL* IX, 10, dated 341 A.D. ([32], pp. 220-222; [30]).

³³ Investigations have brought to light vestiges of a possible late Republican villa (II century B.C.) and a fishing village from Imperial times ([10]; [3], p. 92).

- [8] AURIEMMA R. (2004) - *Salentum a salo. 1. Porti e approdi, rotte e scambi lungo la costa adriatica del Salento. 2. Forma Maris Antiqui*, Galatina.
- [9] AURIEMMA R. (2012) - *Nuovi dati dalla costa adriatica e ionica del Salento*, *Histria Antiqua* 21, 539-556.
- [10] AURIEMMA R., PIRELLI C., RUCCO G. (2016) - *Il paesaggio come Museo. Archeologia della costa di Nardò*, *Notiziario del Portale Numismatico dello Stato* 8, 144-151.
- [11] CERA G. (2012) - *L'insediamento di località Li Schiavoni presso Porto Cesareo*, *ATTA* 22, 75-86.
- [12] CERA G. (c.s. a) - *L'insediamento di località Li Schiavoni (Nardò - Lecce)*, *Dagli Aerostati ai Droni: le immagini aeree in Archeologia*, 2° Convegno Internazionale di Archeologia Aerea (Roma 2016).
- [13] CERA G. (c.s. b) - *Nuove ricerche nel centro fortificato messapico di località Li Schiavoni (Nardò, Lecce). Considerazioni preliminari sulle campagne di scavo 2016-2019*, *Fold&R*.
- [14] D'ANDRIA F. (1978) - *Ugento. Torre S. Giovanni (Lecce)*, *StEtr* XLVI, 564-565.
- [15] D'ANDRIA F. (a cura di) (1990a), *Archeologia dei Messapi*, Catalogo della mostra, Bari.
- [16] D'ANDRIA F. (1991) - *Insedimenti e territorio: l'età storica*, *Atti del XXX Convegno di Studi sulla Magna Grecia (Taranto 1990)*, Napoli 393-478.
- [17] D'ANDRIA F. (2005) - *Le trasformazioni dell'insediamento*, *Cavallino: pietre, case e città della Messapia arcaica, Ceglie Messapica*, 35-43.
- [18] DESANTIS C. (1978) - *Sava, Monte Masciuolo. Torre classica e strutture medievali (F. 203, III SO, Sava)*, *RicSt* XI, 148-151.
- [19] DE SANTIS V. (2003) - *Li Castelli*, in *GUAITOLI* 2003, 317-319.
- [20] DESCOEUDRES J.P., ROBINSON E. (1993) - *La «Chiusa» alla Masseria del Fano. Un sito messapico arcaico presso Salve in provincia di Lecce*, Lecce.
- [21] FERRARI I., SCARDOZZI G. (2016) - *Contributo alla Carta Archeologica di Alezio*, Ugento (Le).
- [22] GIANNOTTA M.T. (1984) - s.v. *Alezio*, *BTCGI* III, Pisa-Roma, 150-153.
- [23] GUAITOLI M. (a cura di) (2003), *Lo sguardo di Icaro. Le collezioni dell'Aerofototeca Nazionale per la conoscenza del territorio*, Roma.
- [24] GRELLE F., SILVESTRINI M. (2013), *La Puglia nel mondo romano. Storia di una periferia. Dalle guerre sannitiche alla guerra sociale*, Bari.
- [25] LA BUA V. (1992) - *Il Salento e i Messapi di fronte al conflitto tra Annibale e Roma*, G. UGGERI (a cura), *L'età annibalica e la Puglia. Atti del II Convegno di Studi sulla Puglia romana (Mesagne 1988)*, Mesagne, 43-69.
- [26] LEPORE (a cura di) (2000) - *Il sito antico de Li Castelli presso Manduria (Taranto). Gli scavi, i risultati, le prospettive*, Manduria.
- [27] LIPPOLIS E. (1991) - *Porto Cesareo, statua della divinità egiziana Thot*, *Vecchi scavi, nuovi restauri*, Catalogo della Mostra, Taranto, 11-15.
- [28] LOMBARDO M. (2014) - *Iapygians: The Indigenous Populations of Ancient Apulia in the Fifth and Fourth Centuries B.C.E.*, CARPENTER T.H., LYNCH K.M., ROBINSON E.G.D. (ed. by), *The Italic People of Ancient Apulia. New Evidence from Pottery for Workshops, Markets and Customs*, Cambridge, 36-67.
- [29] MAGGIULLI G. (2012) - s.v. *Ugento*, *BTCGI* XXI, 385-397.

- [30] MARANGIO C. (2004) - *CIL IX, 10 e il porto di Neretum*, M. KHANOUSI, P. RUGGERI, C. VISMARA (a cura di), *L'Africa Romana. Lo spazio marittimo del Mediterraneo occidentale. Geografia storica ed economica*, Atti del XIV Convegno di studio (Sassari 2000), Roma, 891-904.
- [31] MARANGIO C. (2006) - *Porti e approdi della Puglia romana*, JAT XVI, 101-128.
- [32] MASTRONUZZI G. (1995) - *Ricerche archeologiche a Nardò (Le)*, StAnt 8, 1, 183-228.
- [33] MASTRONUZZI G. (2005) - *Repertorio dei contesti culturali indigeni in Italia meridionale. I. Età arcaica*, Bari.
- [34] MASTRONUZZI G. (2013) - *Il luogo di culto di Monte Papalucio ad Oria. I. La fase arcaica*, Bari.
- [35] MASTRONUZZI G., CALDAROLA R. (2019) - *I paesaggi costieri del Salento messapico alla luce delle recenti indagini archeologiche*, in FIORIELLO C.S., TASSAUX F. (a cura di), *I paesaggi costieri dell'Adriatico tra Antichità e Altomedioevo*, Atti della Tavola Rotonda (Bari 2017), Bordeaux, 183-208.
- [36] MERO TRIPALDI E. (1974) - *Maruggio, Torre Ovo. Strutture portuali; abitato e necropoli*, in RicSt VII, 80-84.
- [37] PACE B. (1953) - *Una statuetta del dio Toth-cinocefalo nel Museo Nazionale di Taranto*, RAL VIII, 119-121.
- [38] PICHIERRI G. (1978): *Taranto. Santuari del IV sec. a.C. Torre dell'Ovo*, RicSt XI, 156-158.
- [39] SAMMARCO M. (2003) - *Masseria Fano*, GUAITOLI 2003, 341-343.
- [40] SAMMARCO M. (2003a) - *Vereto*, GUAITOLI 2003, 346-349.
- [41] SAMMARCO M. (2012) - s.v. *Vereto*, BTCGI XXI, 817-825.
- [42] SCHIAVANO P. (2010) - s.v. *Scala di Furno*, BTCGI XVIII, 439-442.
- [43] SEMERARO G. (1996) - s.v. *Porto Cesareo*, BTCGI XIV, 258-259.
- [44] SEMERARO G. (2003) - *S. Vito dei Normanni*, in GUAITOLI 2003, 320-322.
- [45] TARENTINI P. (2006) - *Monacizzo. Un antico centro magnogreco e medievale a sud-est di Taranto*, Manduria (Taranto).
- [46] UGGERI G. (1974) - *Porto Cesareo, Torre Chianca. Industria purpuraria romana (F. 213, I, NE, Porto Cesareo)*, RicSt VII, 74-75.
- [47] UGGERI G. (1983) - *La viabilità romana nel Salento*, Mesagne.

PYRGI: ANALYSIS OF POSSIBLE CLIMATIC EFFECTS ON A COASTAL ARCHAEOLOGICAL SITE

Virginia Coletta^{1,2,*}, Fernanda Prestileo², Paolo Allasia³, Alessandra Bonazza⁴,
Alessandro Ciarravano², Stefano Federico², Davide Notti³,
Rosa Claudia Torcasio², Mattia Crespi¹ Stefano Dietrich²

¹ Geodesy and Geomatics Division - DICEA, Sapienza University of Rome
Via Eudossiana 18 – 00184 Rome (Italy), e-mail: virginia.coletta@uniroma1.it

² CNR - Institute of Atmospheric Sciences and Climate, Rome (Italy)

³ CNR- Research institute for geo-hydrological protection, Turin (Italy)

⁴ CNR - Institute of Atmospheric Sciences and Climate, Bologna (Italy)

Abstract – This work refers to an interdisciplinary study on the archaeological site of Pyrgi, an Etruscan harbour still under excavation, located on the Lazio's coast in Santa Severa, in the province of Rome. The site in question is subject to frequent flooding which compromises its accessibility and delays the archaeological excavation operations. The study is based on the combined use of geomatic technologies, meteorological and climatic models, and hydrogeological knowledge of the examined site, to have a global view of the hazard to which it is exposed. Different geomatic techniques at different scales are used in the analysis. Large scale surveys are carried out to define the water networks and to monitor the site using satellite images. On a small scale, drone photogrammetry techniques are used to assess the morphology of the territory and eventual protection from natural hazards present in the site. Using these images, a detailed digital surface model (DSM) has been generated.

The objective of the research is to assess the main cause of the floods and the time the water stays in the site and to determine if the floods are periodic phenomena over time or random events. The study was conducted using images captured by Sentinel 2 satellites processed at level 2-A. These images enabled the identification of the flooding periods of the site for the years of monitoring. The study was conducted by comparing the captured images with rainfall data, paying attention to extreme weather phenomena that occurred from 2012 to date. The rainfall data are provided by the National Department of Civil Protection to CNR-ISAC by an agreement between the two institutions. The same images have been compared with the wind data recorded by the anemometer located in the Civitavecchia harbour and the wave height data available from ERA5 reanalysis. Knowledge of the main cause of the floods and a possible periodicity will allow to plan correct conservation of the site through specific protection measures designed according to the hazards to which it is exposed.

Introduction

The cultural heritage is subject to continuous interaction with the surrounding territories, with consequent exposure to different types of hazard, both manmade and natural, which affect its conservation over time. Due to changes in climatic conditions demonstrated in recent years, with a consequent increase in the frequency and intensity of

extreme weather phenomena, hydrogeological instability is causing increasing damages to cultural heritage [4] [5] [10]. This has a potential impact on the built and landscape heritage, which frequently fails to have appropriate protection systems [14] [18] [19] [20]. As a peninsula, Italy shows part of its cultural heritage located along the coasts, where important dangerousness of sea storms exists. Any area close to the coastline, as well as suffering flood damage, can be subject to coastal erosion and absorption of saltwater into the site, which undermines the fragile balance between monument and land, or even to permanent submersion of part of the area [5] [10] [17].

The case study is Pyrgi, an Etruscan harbour still under excavation, supervised by the Sapienza University of Rome, Department of Classic in particular under the Scientific Responsibility of Professor Laura Michetti, located along the Lazio coast in Santa Severa (RM) (Figure 1) [2]. As can be seen in Figure 1 the site is located only a few meters from the coastline.

Pyrgi was the harbour of an ancient Etruscan city, Caere, and played a fundamental role in maritime transport, being frequented by Greek and Phoenician ships. The emerged area includes a ceremonial district and two different sanctuary areas: Monumental and Southern (Figure 1) [2] [8] [12]. A consistent part of the area is completely submerged by the sea that includes the harbour site [1] [2] [7] [16].



Figure 1 - Geo-localization of Pyrgi and subdivision of the sanctuary complex: at the top left Ceremonial District; in the centre the Monumental Sanctuary; at the bottom right the Southern Sanctuary. (Google Earth Image © 2020 TerraMetrics ©2020 Google).

Over the years, the site has suffered repeatedly flooding events, characterized by a strong transport of solid sludge and permanence of water in the site, which can cause damage, delay of the archaeological excavation work, and a complete submersion of the site in the future [1]. In the area under consideration, as can be seen in Figure 1, no structures built over the ground exist, but ruins located at lower ground level, potentially transforming into large basins of water after a heavy storm and consequent floods (Figure 2).

Aim of this study is to investigate the causes of flooding, deepening how long the water covered the site, and the incidence of flooding events over the years (return period) in order to estimate whether they are sporadic or permanent phenomena. The aim is achieved by an interdisciplinary approach based on exploring meteorological datasets, performing hydrogeological investigations, and examining site images at different scales. Satellite images provided by Sentinel-2 level-2-A (S2-A) were used to monitoring the area and its surroundings [11] [6], and drone images helped to construct a Digital Surface Model (DSM) [15]. All this information was analysed, meteorological data have been correlated with satellite images and geological surveys to have a global view of the site and flooding conditions.



a) Ceremonial District



b) Monumental Sanctuary

Figure 2 - View of the flooded archaeological site after the thunderstorm of 15th November 2019 (photos by the authors taken on 20th November 2019).

Materials and Methods

In the frame of this investigation, a Digital Surface Model (DSM) was generated from drone images¹ taken on October 5, 2017. These images were collected to inspect the morphology of the terrain. In particular were captured 777 images from different height through a DJI FC6310 camera (resolution of 5742 x 3648 pixel, ground resolution 8 mm/pixel). The images were thus processed by the Agisoft Photoscanner®, a photogrammetric software, to generate a DSM of the archaeological area. For georeferencing the area, 20 Ground

¹ Images provided by Professor Alessandro Jaia, Sapienza University of Rome, Department of Classic.

Control Point (GCP) were used, so that the DSM is georeferenced in the World Geodetic System (WGS84) reference frame with orthometric heights referred to the Earth Gravitational Model 2008 (EGM2008) geoid model [15]. As GCP have been inserted points clearly visible on the ground and to them have been associated the elevations collected by Google Earth Pro, in which the elevations have a vertical accuracy around 2 m [3]. In the DSM three sections have been generated in front of the main areas of the site starting from the sea and crossing the whole area. These have been designed to assess the morphology of the terrain, along the same sections, and to reveal the presence of possible protections (also anthropogenic) of the site from sea dynamics, such as dunes or protective works as hearsay knows.

S 2-A² satellite images were used to monitor the site and its surroundings.

Sentinel-2 is part of the Sentinel family of satellites developed by the European Space Agency, specifically designed for the operational needs of the Copernicus program. Copernicus is the most ambitious Earth observation program to date. It will provide an Earth observation program that is accurate, timely and easy, accessible information to improve the management of the environment, understand and mitigate the effects of climate change and ensure civil security. Copernicus is the new name of Global Monitoring for Environment and Security Program, formerly known as GMES. This initiative is led by the European Commission (EC) in partnership with the ESA [6].

Sentinel-2 is equipped with a multispectral sensor with 13 spectra having a spatial resolution between 10 m and 60 m; therefore, it is part of the category of optical/passive sensors. It acquires the reflected electromagnetic waves of sunlight and/or infrared radiation emitted by objects on the ground. The objects, being of different materials, reflect and absorb different wavelengths in different ways. In a multispectral sensor, each channel is sensitive to radiation within a narrow wavelength band. The resulting image is a multi-layer image that contains both brightness and spectral (colour) information of the objectives observed. Since visible/infrared radiation does not pass through the clouds, the images of the terrain cannot be captured during cloudy days³.

S2-A images were used in the investigation. The Level-2A operational processor generates, from algorithms of scene classification and atmospheric correction, Level-2A (BOA reflectance) products from Level-1C products. From the mid-March 2018, the Level-2A became an operational product, beginning with coverage of the Euro-Mediterranean region. Global coverage started in December 2018⁴.

In the images used in this investigation, the following bands (B) were used: SWIR 2 (B12 resolution 20 m), SWIR 1 (B11 resolution 20 m), Blue (B2 resolution 10 m), Green (B3 resolution 10 m), Red (B4 resolution 10 m).

Being these data heavy, we used Google Earth Engine⁵ for the elaboration. It is a cloud computing platform released by Google for petabyte-scale scientific analysis and visualization of geospatial datasets, both for the public benefit and for business, and government users. Earth Engine stores satellite imagery organizes it and makes it available

² <https://sentinel.esa.int/web/sentinel/missions/sentinel-2>

³ <https://directory.eoportal.org/web/eoportal/satellite-missions/c-missions/copernicus-sentinel-2>

⁴ <https://earth.esa.int/web/sentinel/technical-guides/sentinel-2-msi/level-2a-processing>

⁵ <https://www.geoinformers.com/post/2018-01-13-google-earth-engine-for-scientific-analysis-and-visualization-of-geospatial-datasets>

for the first time for global-scale data mining. The public data archive includes historical earth imagery going back more than forty years, and new imagery is collected every day. Earth Engine also provides APIs in JavaScript and Python, as well as other tools, to enable the analysis of large datasets [9].

In addition to aerial and satellite imagery, ground data were used. The rain gauges precipitation data have been provided by the National Department of Civil Protection⁶, based on a specific agreement with CNR-ISAC. Hourly rainfall and overall daily precipitations were collected from January 2012 until December 2019, specifically considering days with more than 60 mm of rain. To have further information over the site, also correcting missing data caused by incorrect sensor performance, in addition to the rain gauge located in the Santa Severa station, we also examined the data of the rain gauges in Civitavecchia (north-west), Bracciano (north-east) and Cerveteri (south-east) of Lazio Region.

For the wave heights, the ERA 5 reanalysis was used on a site near Civitavecchia. ERA 5 is the fifth generation of the ECMWF's atmospheric global climate reanalysis, covering the years from 1979 to the present with hourly resolution and a horizontal resolution of $0.25^\circ \times 0.25^\circ$ ⁷.

For wind and tide data, those provided by the national maritime network have been used; the measurements are related to the anemometer and the buoy in the port of Civitavecchia⁸. Concerning wind and wave heights analysis, the specific directions were previously selected, i.e. can affect the coast and therefore cause sea storms, then daily average and maximum wind velocity and wave height were calculated.

Previous analyses⁹ of soil stratigraphy of the Monumental Sanctuary show, from the top, the following sedimentary sequence: (1) the archaeological layer, at least 2 m thick; (2) a silty-sandy alluvial layer, 3÷5 m thick; (3) a predominantly sandy layer, 2.5÷7 m thick, often interbedded by silty-sand levels; (4) a much more coherent layer, between 4 m and 7 m thick, including cemented deposits similar to beach rock; (5) a very stiff clay layer at the bottom [13].

Once all the information has been collected, the different data have been related to each other to achieve the goal of this study.

Results and Discussion

Different possible causes for the recurrent flooding of the archaeological site of Pyrgi were analysed: flooding of water bodies, rising of groundwater, heavy rains, sea storms. In this research we assess what is the main cause of the flooding of the Pyrgi site, the time the water stays in the site and whether the phenomenon occurs with a certain periodicity.

Considering the single causes of flooding, the hydrogeological maps elaborated by the Lazio Region, does not evidence the presence of rivers with high flow or important aquifers in the area of interest¹⁰, what seems excluding considerable contributions to the

⁶ <http://www.protezionecivile.gov.it/>

⁷ The data are provided in grid version available on Copernicus website: <https://cds.climate.copernicus.eu/>

⁸ <https://www.mareografico.it/>

⁹ Analysis carried out by Professor Luciana Orlando, Sapienza University of Rome, Department of Civil, Constructional and Environmental Engineering.

¹⁰ Map available at the following link:

http://www.regione.lazio.it/prl_ambiente/?vw=documentazioneDettaglio&id=8672

flooding related to rivers and aquifers. To confirm this, in figure 3-b it can be observed that floods occur only along the coast and not in the hinterland.

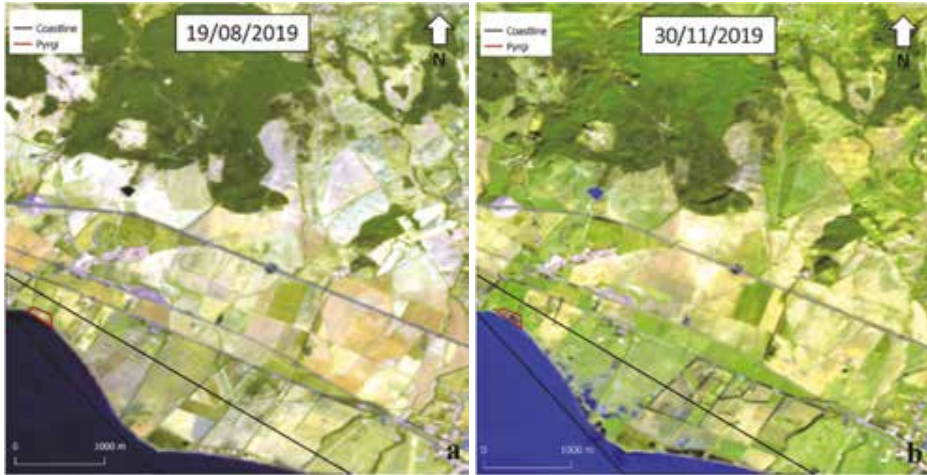

Figure 3 - Comparison of images captured by Sentinel 2-A and processed with Google Earth Engine of the same area in summer, image captured on 19 August 2019 (a), and in autumn, image captured on 30 November 2019 (b).

Once the component associated with rivers and aquifers was excluded as the main cause of flooding, the contribution of rainy events was examined. The days of heavy rainfall (greater than 60 mm/day) were correlated with the first available satellite image (S2-A) after the event. In this text only one heavy rain event is reported as an example, considering that for all the other analysed heavy rainfall events (from 2012 to date have been identified 17 heavy rainfall events) the site showed the same response. As can be seen from Figure 4, the site is not flooded after the single heavy rainfall event. Considering the extent of the flooded area and the permeability characteristics of the soil [13], the single heavy rainfall event is not sufficient to cause the flooding of the site.

Table 1 - Rainfall event greater than 60 mm/day in Santa Severa registered from all pluviometer around the site.

Date	S. Severa	Cerveteri	Bracciano	Civitavecchia
	[mm]	[mm]	[mm]	[mm]
04-10-2018	0.00	0.00	0.00	0.00
05-10-2018	14.80	12.30	10.10	16.60
06-10-2018	78.80	50.00	87.30	15.80
07-10-2018	3.20	3.00	2.70	0.40
08-10-2018	0.00	0.00	0.80	0.00



Figure 4 - Image, captured in data 13th October 2018, by satellite Sentinel 2-A after a rainfall greater than 60 mm.

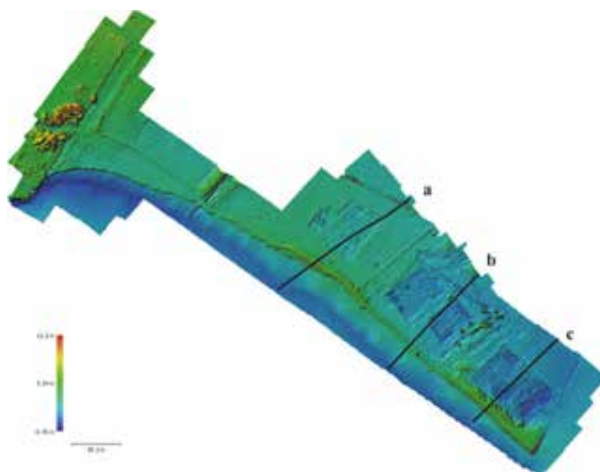

Figure 5 - Digital Surface Model developed with Agisoft®.

Excluding hydrogeological events and severe rainfalls as the principal causes of flooding, sea storms should be analysed. As a first study, it was considered if the site was equipped with sea storm protections. For this purpose, a DSM of the study area was built from drone images (Figure 5), with a resolution of 1.6 cm/pix and point density of 0.391 point/cm². Three sections have been generated, in front of the three principal areas, to highlight the presence of sea storm protection. This specific analysis is derived from the visit to the archaeological site, in which the remains of some dunes were evident, that were created by

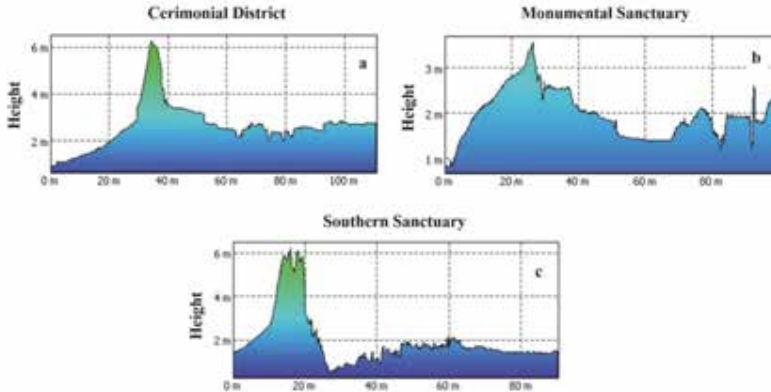

Figure 6 - Surface development in the three different sections shown in Figure 5: Cerimonial District; Monumental Sanctuary; Southern Sanctuary.

accumulating digged ground. Figures 6-a and 6-c show elevations with heights up to 6 m in the boundary line between the site and the beach, associated with storm protection in the area. This, however, is absent in figure 6-b where there are no high elevations and consequently no protection, so the site is exposed to sea dynamics.

To assess if the sea is the primary cause of the flooding of the site the period in which the site is submerged has been identified through S2-A (Figure 7); the site is mainly flooded from November to May. Wind speeds and wave heights are intense during the same months. In particular, the monthly maxima of wave heights are very high, up to 3 m high waves. Also the wind speeds are very high, with peaks over 9 m/s in particular during the autumn and winter months. The data reported do not take tides into account, being the tide variations around 30 cm and so they have been considered negligible in this study.

Table 2 - Monthly data for flooded period of 2018-2019.

Date	Average Wind Speed [m/s]	Maximum Wind Speed [m/s]	Average Significant Wave Height [m]	Maximum Significant Wave Height [m]
September	1.67	10.10	0.46	1.97
October	2.60	14.20	0.99	5.71
November	2.47	10.00	0.97	2.78
December	2.02	10.20	0.87	2.99
January	2.79	11.00	1.02	2.56
February	2.34	10.20	0.90	2.80
March	2.81	9.50	0.83	3.44
April	3.49	13.00	0.73	3.31
May	2.87	8.90	0.82	3.30
June	2.90	9.00	0.45	1.92
July	2.70	9.00	0.44	1.32
August	2.43	7.70	0.34	1.22

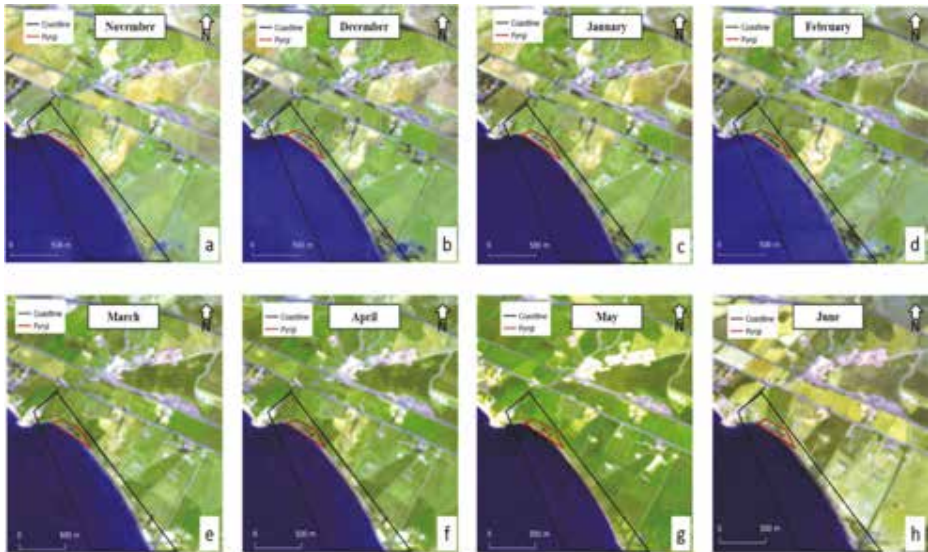

Figure 7 - Pictures taken by Sentinel 2-A and processed with Google Earth Engine for the month of November 2018 (a), December 2018 (b), January 2019 (c), February 2019 (d), March 2019 (e), April 2019 (f), May 2019 (g), June 2019 (h).

Upstream of all the analyses, it can be said that the main cause of the flooding at the archaeological area is the maritime component, since the area in which it is exposed to storm surges and the site without adequate protection. It is also noted that in June wind speeds and wave heights decrease and the drying up period of the area begins, lasting several weeks (Figure 7 h).

Conclusion

The aim of this interdisciplinary work, in collaboration with the Sapienza University of Rome, Department of Classics, and the Soprintendenza archeologica, belle arti e paesaggio per l'area metropolitana di Roma, la provincia di Viterbo e l'Etruria meridionale, has been to assess the period of flooding of the archaeological site of Pyrgi and the main cause of the flooding. The combination of different disciplines as geomatics, meteorology, and hydrogeology, in relation to the data coming from the historical-archaeological and geological researches, has been used to conduct a complete study and continuous monitoring of the area and the hazards that expose it to specific dangers.

The archaeological site of Pyrgi is one of the largest Etruscan harbour in Italy, with inestimable archaeological value, still under excavation by the Sapienza University of Rome, Department of Classics. Its position on the coast exposes this site to many risks that potentially compromise its conservation, fruition, and valorisation.

Currently, part of the archaeological area is completely flooded, while the ruins that have emerged, based on the analysis reported in this work, are covered by water for

seven months, during the eighth month the physical forcing decreases in intensity and the air begins the drying phase.

The other result highlighted in this study is the role of the sea as the main risk factor for flooding rather than local rivers or aquifers and rainfall due to its short duration. The DSM shows that the site is currently fully exposed to meteorological and hydrogeological instabilities so that, in the absence of protective measures, it could easily be compromised. The presence of water in the long term could compromise the fragile balance between the monumental ruins and the ground, delaying excavations and leading to total submersion of the area soon.

Future studies will focus on the creation of a higher resolution DEM including bathymetry to develop wave propagation and simulate a sea storm event. Statistical studies will be carried out covering all the maritime components to suggest possible protection of the site. In addition, further geological analysis will be conducted to calculate the absorption velocity of the soil and the actual contribution of rainfall and groundwater to the flooding of the site will be assessed.

Acknowledgements

The authors want to express their gratitude to Dr. Rossella Zaccagnini of the *Soprintendenza archeologica, belle arti e paesaggio per l'area metropolitana di Roma, la provincia di Viterbo e l'Etruria meridionale* for having signalled us the site and its problems. Furthermore, they want to express their gratefulness to Professor Laura Michetti for the fruitful support and collaboration during the visit at the archaeological site of Pyrgi and to Prof. Alessandro Iaia for made available to us the drone imagery.

References

- [1] Anzidei M., Doumaz F., Vecchio A., Serpelloni E., Pizzimenti L., Civico R., Enei F. (2020) - *Sea level rise scenario for 2100 AD in the heritage site of Pyrgi (Santa Severa, Italy)*. Journal of Marine Science and Engineering, 8(2), 64.
- [2] Baglione M. P., Belelli Marchesini B., Carlucci C., Michetti L. M. (2017) - *Pyrgi, harbour and sanctuary of Caere: landscape, urbanistic planning and architectural features*. Archeologia e calcolatori, 28(2), 201-210.
- [3] Benker S. C., Langford R. P., Pavlis T. L. (2011). *Positional accuracy of the Google Earth terrain model derived from stratigraphic unconformities in the Big Bend region, Texas, USA*. Geocarto International, 26(4), 291-303.
- [4] Bonazza A., Maxwell I., Drdácý M., Vintzileou E., Hanus C. (2018) - *Safeguarding Cultural Heritage from Natural and Man-Made Disasters: A comparative analysis of risk management in the EU*. Publications Office of the European Union
- [5] Drdácý M. F. (2010) - *Flood damage to historic buildings and structures*. Journal of Performance of Constructed Facilities, 24(5), 439-445.
- [6] Drusch M., Del Bello U., Carlier S., Colin O., Fernandez V., Gascon F., Meygret A. (2012). *Sentinel-2: ESA's optical high-resolution mission for GMES operational services*. Remote sensing of Environment, 120, 25-36.

- [7] Enei, F., Marittimi M. C. A. C. S. (2004) - *Pyrgi sommersa: ricognizioni archeologiche subacquee nel porto dell'antica Caere*, Historia Editore, Roma
- [8] Enei, F. (2013) - *Santa Severa: tra leggenda e realtà storica: Pyrgi e il Castello di Santa Severa alla luce delle recenti scoperte (scava 2003-2009)*.
- [9] Gorelick N., Hancher M., Dixon M., Ilyushchenko S., Thau D., Moore R. (2017) - *Google Earth Engine: Planetary-scale geospatial analysis for everyone*. Remote Sensing of Environment, 202, 18-27
- [10] Herle I., Herbstová V., Kupka M., Kolymbas D. (2010) - *Geotechnical problems of cultural heritage due to floods*. Journal of Performance of Constructed Facilities, 24(5), 446-451.
- [11] Martimort P., Arino O., Berger M., Biasutti R., Carnicero B., Del Bello U., Spoto F. (2007) - *Sentinel-2 optical high resolution mission for GMES operational services*. In 2007 IEEE International Geoscience and Remote Sensing Symposium, pp. 2677-2680.
- [12] Michetti L. M. (2016) - *Ports: Trade, Cultural Connections, Sanctuaries and Emporia. Caere (Cities of the Etruscans, 1)*. ed. Nancy de Grummond and Lisa C. Pieraccini, University of Texas Press, Austin, 73-86.
- [13] Orlando L., Michetti L. M., Belevi Marchesini B., Papeschi P., Giannino F. (2019) - *Dense georadar survey for a large-scale reconstruction of the archaeological site of Pyrgi (Santa Severa, Rome)*. Archaeological Prospection, 26(4), 369-377.
- [14] Phillips, H. (2015) - *The capacity to adapt to climate change at heritage sites — The development of a conceptual framework*, Environmental Science & Policy, 47, 118-125.
- [15] Ravanelli R., Riguzzi F., Anzidei M., Vecchio A., Nigro L., Spagnoli F., Crespi, M. (2019) - *Sea level rise scenario for 2100 AD for the archaeological site of Motya*. Rendiconti Lincei. Scienze Fisiche e Naturali, 30(4), 747-757
- [16] Rovere A., Antonioli F., Enei F., Giorgi S. (2011) - *Relative sea level change at the archaeological site of Pyrgi (Santa Severa, Rome) during the last seven millennia*. Quaternary International, 232(1-2), 82-91
- [17] Sabbioni C., Cassar M., Brimblecombe P., Lefevre R. A. (2008) - *Vulnerability of cultural heritage to climate change. EUR-OPA major hazards agreement*, EUR-OPA major hazards agreement, Council of Europe November
- [18] Sesana E., Gagnon A. S., Bonazza A., Hughes J. J. (2020) - *An integrated approach for assessing the vulnerability of World Heritage Sites to climate change impacts*, Journal of Cultural Heritage, 41, 211-224.
- [19] Spennemann D. H., Graham K. (2007) - *The importance of heritage preservation in natural disaster situations*. International Journal of Risk Assessment and Management, 7(6-7), 993-1001.
- [20] Wang J. J. (2015) - *Flood risk maps to cultural heritage: Measures and process*. Journal of Cultural Heritage, 16(2), 210-220.

THE MONASTIC HERITAGE IN THE SARONIC GULF (GREECE). ARCHITECTURAL AND ENVIRONMENTAL SURVEYS OF THE ARCHITECTURE AND COASTLINE

Luigi Corniello, Andronira Burda, Adriana Trematerra, Davide Carleo,
Angelo De Cicco, Martina Gargiulo, Fabiana Guerriero, Gennaro Pio Lento
Università della Campania “Luigi Vanvitelli”
Dipartimento di Architettura e Disegno Industriale, Aversa, Italia
e-mail: luigi.corniello@unicampania.it

Abstract – The research itinerary is aimed at getting to know the monastic complexes in the Saronic Gulf (Greece) with operations of an investigative nature, to which are added references on religious and environmental themes which, in relation to architecture, expose the compositional and structural beauty of the Greek coastline. They are readings of structures that refer to the territory with analyses that determine knowledge suitable to be represented and documented in the main dimensions of the research.

The final objective of the research is to promote the development of the territory through the protection and enhancement of the architectural and cultural resources present.

The study presents the survey of some Monasteries in the Saronic Gulf in southern Greece, such as the Monastery of the Spring Fountain on the island of Poros, the Monastery of the Assumption of the Virgin Mary on the island of Hydra and the Monastery of St. Nicholas in Spetses. These architectural structures present a poor graphic and iconographic documentation, therefore the research, through some manual and instrumental surveys, proposes a knowledge of the places through drawing.

The activities of investigation of the religious architectures have foreseen several survey campaigns aimed at the knowledge of the structures and the surrounding territory: the graphic analyses, in fact, have produced a first geometric model subsequently enlarged with architectural details. Adequate photographic documentation was also carried out, in addition to checking the scarce bibliographic, archival and iconographic documentation.

Introduction

The study presents the survey of some Monasteries in the Saronic Gulf in southern Greece, such as the Monastery of the Spring Fountain on the island of Poros, the Monastery of the Assumption of the Virgin Mary on the island of Hydra and the Monastery of St. Nicholas in Spetses. These architectural structures present a scarce graphic and iconographic documentation, therefore the research, through some manual and instrumental surveys, proposes a knowledge of the places through drawing.

The activities of investigation of the religious architectures have foreseen several survey campaigns aimed at the knowledge of the structures and the surrounding territory: the graphic analyses, in fact, have produced a first geometric model subsequently enlarged with architectural details.



Figure 1 - The Monastery of the Spring Spring on the island of Poros. View from the west coast.

An adequate photographic documentation has also been carried out, in addition to checking the poor bibliographic, archival and iconographic documentation. In this system of representation, the photographic image, in addition to constituting a database value which can be drawn on even after the survey phase, the possibility of interpolating this static figurative data with dynamic computer elements is evident.

For the knowledge activities, we have taken into account the Ryobi laser instrumentation applied on a portable computer support, both tablet and smartphone, which allows an immediate vision of the relief data on the photographic image taken from the support, transforming it into a dynamic data. The support of this photographic technology becomes the main surveying tool because it contains both the measurement data and the geographical coordinates connected to the device used, as well as information regarding the date and time of the survey campaign.

The Saronic religious complexes are proposed, in this path of knowledge, in their current religious functions and in their configurations rich of interest on the analysis of their respective architectures: community buildings, churches, service structures, cells.

The architectural installations display harmonious lines grafted into the urban complexes or into the natural greenery that envelops them in an aura of contemplative participation that is also testified by recent photographic footage of a useful approach to knowledge of the complexes in the landscape.

Of the Monasteries under examination, the dimensions, the open and closed spaces, the geographical configurations in their specific regularization of the sacred perimeter destined to the hermitage of the community factories and the pertinent church have been noted. Of the three complexes under examination, the knowledge of the current aspects, of their uses, is tackled through manual and instrumental surveys, graphic returns compared to archive drawings that attest to their past function.

The monastic architecture in the Saronic Gulf

In order to analyse the monastic architecture in the Saronic Gulf, it is essential to analyse the bibliographic and historical sources as well as a brief description of the structures.

The Monastery of the Spring Fountain, located on the island of Poros in a thick pine forest not far from the city centre of the same name, was founded in the 18th century near the only local fresh water spring which, as local legends tell, miraculously healed the Archbishop of Athens in 1720. A mystical place, recognized in 1733 by the Patriarch of Constantinople under his own jurisdiction from which he obtained numerous economic privileges, in 1814 it hosted a group of monks from Mount Athos who contributed to the architectural and spiritual growth of the place. A few years later, within the premises on the ground floor, the first orphanage of the Greek nation was founded for the orphans of the warriors of the War of Independence.

Currently the Monastery consists of a building with a central courtyard in which stands the Church with a dome and a bell tower. The double level hermitage has in the lower part the service rooms such as a refectory, kitchens, storerooms and rooms for the reception of the faithful, and in the upper part the monks' cells, 17 of which are occupied.

The Monastery of the Assumption of the Virgin Mary located on the island of Hydra, also occupies a dominant position over the port overlooked by the ponderous clock tower. Documentary sources identify a first religious complex already in 1643 consisting of a central church and a nucleus of cloistered cells of the 18 religious women.

The structure was destroyed in 1774 by a violent earthquake and rebuilt in the following years with Venetian architectural influences deriving from the Serenissima domination in the Mediterranean.

The same type of building, named after the Assumption of the Virgin Mary, however, was entrusted to a group of Orthodox monks.

The Cathedral, in Byzantine style, has three naves ending in three semicircular apses with frescoes from the 18th century: the interior preserves numerous icons in gold and silver from the Byzantine period and in the centre of the central dome hangs an imposing gilded chandelier.

In the monastic enclosure there are two bell towers, the first, dating back to 1643 and remodelled in 1806, on three levels is covered in marble and was designed by Venetian and Genoese architects for the previous women's monastery, the second, larger, dating back to 1874.



Figure 2 - The Monastery of the Assumption of the Virgin Mary on the island of Hydra. View of the religious structure and the port.

Currently the side courtyard houses the busts of some of the heroes of the Greek War of Independence of 1821 against the Turkish people, in memory of the transformation of the religious structure into a military quarter: the monastic cells, in fact, were used as chambers for admirals and captains who managed the military attacks against the Near East.

The Monastery of St. Nicholas in Spetses, finally, is located along the northern coastal strip of the island and in 1821 it represented the political, as well as religious, center of the local community. In fact, during the War of Independence, it was the place where battles and military strategies were agreed upon by captains, lords of the island and priests.

The main entrance portal, facing west, is characterized by a ponderous entrance portal surmounted by the bell tower built in 1805 with marble from the island of Tinos.

The entire complex on a double level with a central courtyard and a church with a nave and two aisles is characterized by a floor made of sea pebbles arranged according to a geometric design.

Towards the east the building is characterized by a single floor, the ground floor, while on the first floor there is a panoramic terrace overlooking the surrounding gulf where there is a portico leading to the monks' cells.



Figure 3 - The Monastery of St. Nicholas on the island of Spetses. View to the east from the sea.

The survey and digital modeling of the Monasteries

The research, based on the disciplinary foundations of architectural drawing, proposes the survey and graphic modeling of the structures under examination.

The study has been carried out through detailed and accurate photographic and iconographic documentation, survey and digital documentation. The present work, therefore, proposes to document and reconstruct graphically, the Monastery of the Spring Fountain on the island of Poros, the Monastery of the Assumption of the Virgin Mary on the island of Hydra and the Monastery of St. Nicholas in Spetses, through a series of digital drawings, but above all through 3D photogrammetric modelling systems. The theme of digital modeling is of great importance, since it allows to face, according to disciplinary assumptions, such as technical-instrumental and theoretical applications, the dynamics of drawing related to both traditional and innovative digital representation.

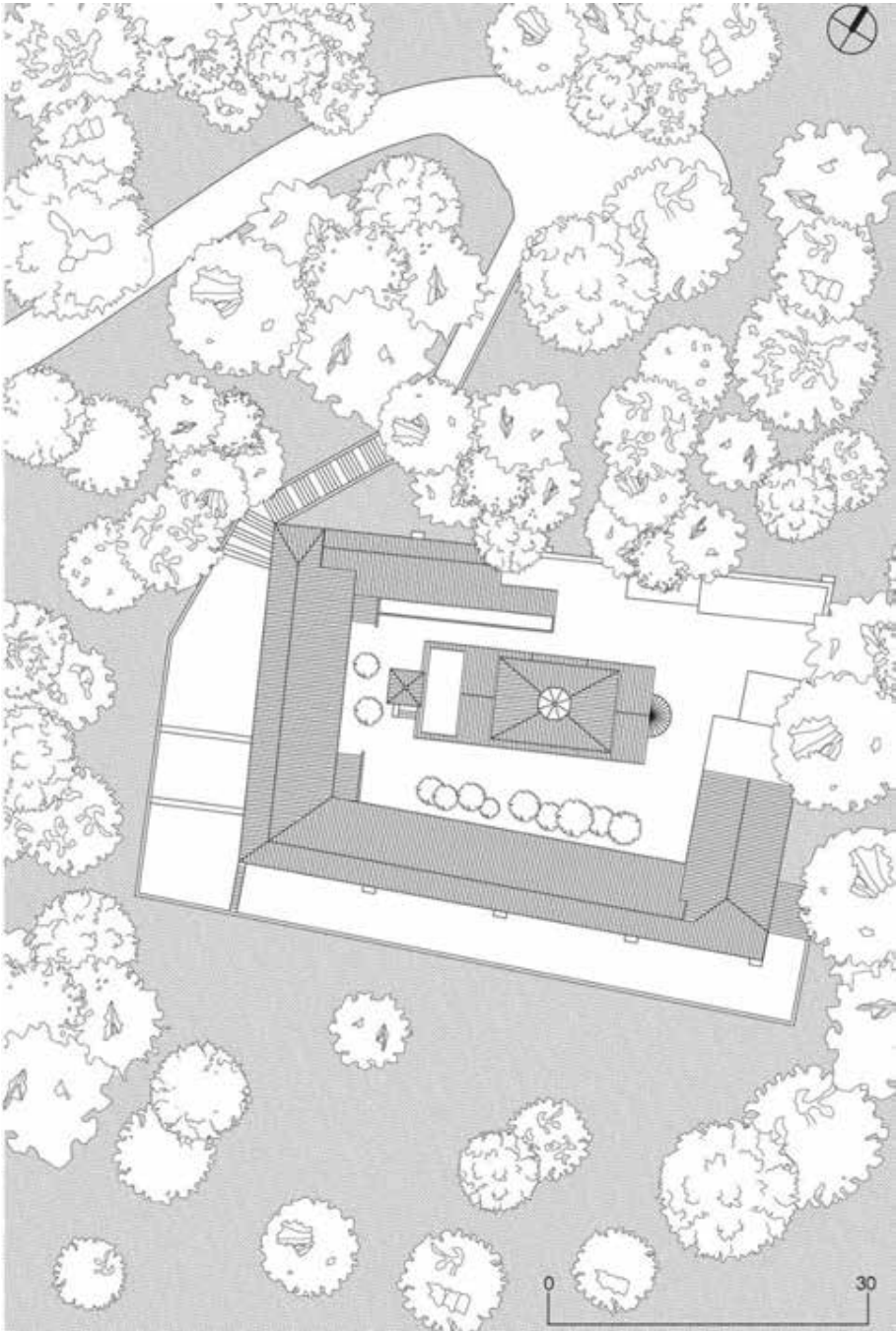

Figure 4 - The Monastery of the Spring Spring on the island of Poros. General plan.

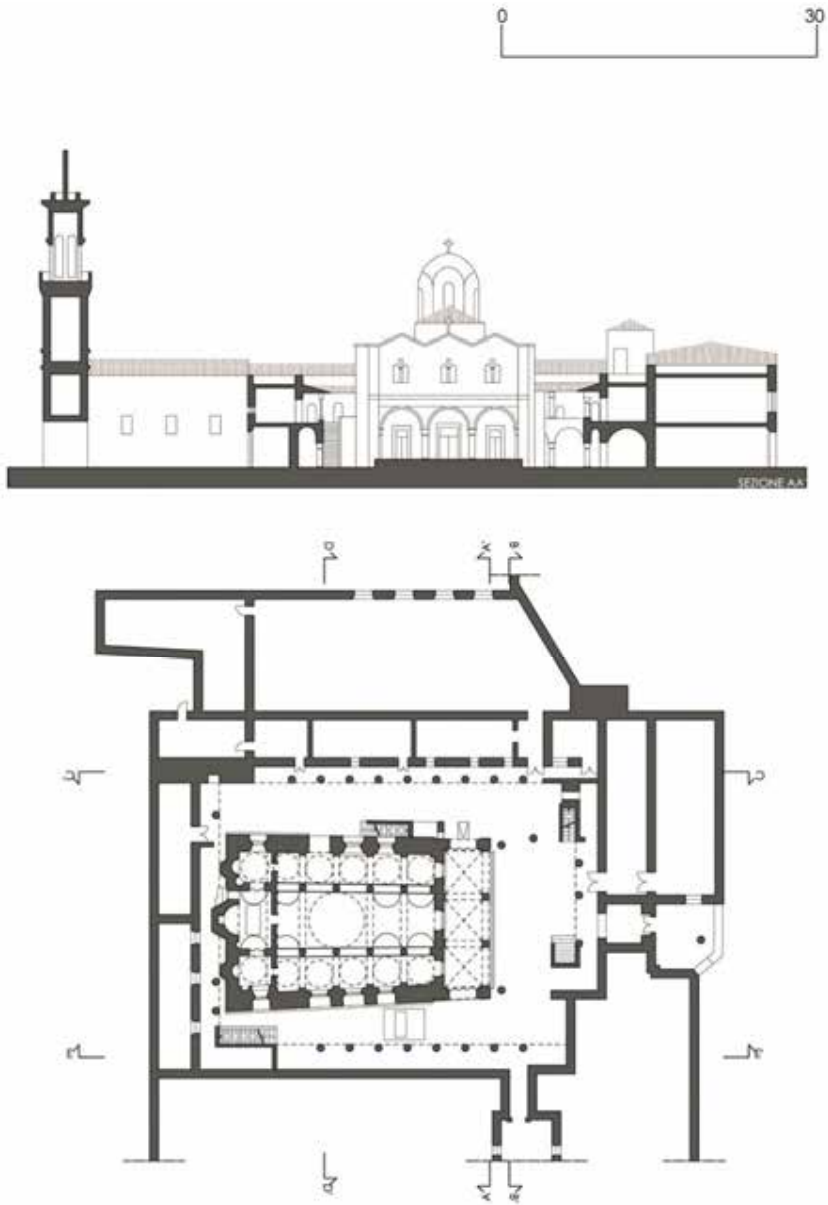

Figure 5 - The Monastery of the Assumption of the Virgin Mary on the island of Hydra. Ground floor plan and transversal section.

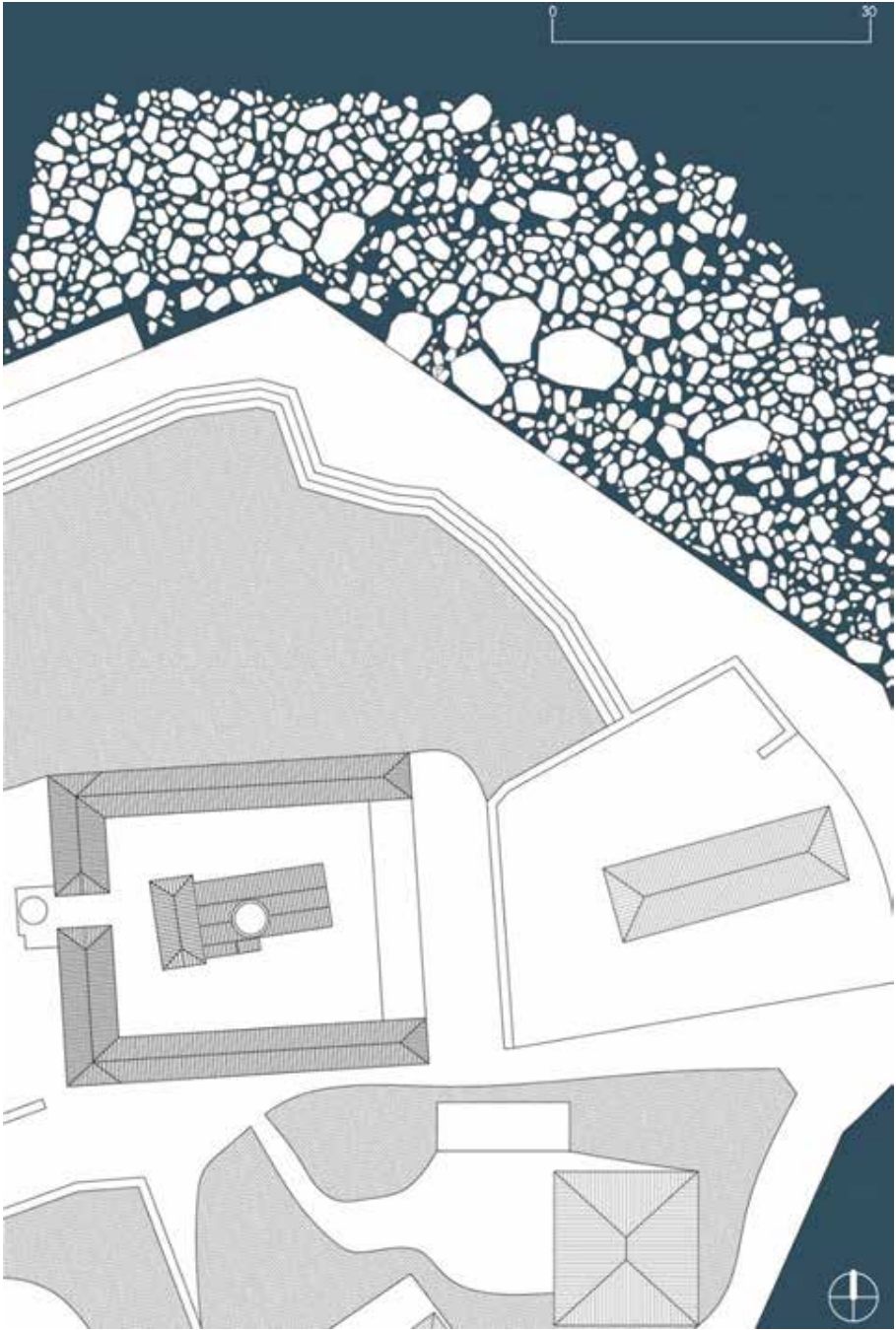

Figure 6 - The Monastery of St. Nicholas on the island of Spetses. General plan of the roofs.

With this science the aspect concerning the visualization is determined, a fundamental element for the communication of the object examined, through which it is possible to define the final graphic rendering compatible with the purpose of the relevant activity, both relative to the knowledge of the existing and indicative for the protection and enhancement of the asset.

Three-dimensional modeling of cultural heritage starting from digital images at different scales and acquisitions with low-cost tools has recently gained attention from the scientific community for the realization of innovative research and advanced digital modeling processes, due also to the availability of new technologies for the recording, processing, management and visualization of 3D data. [Amoruso, Apollonio, Remondino, 2010].

In order to elaborate 3D digital models it is useful to clarify the scientific dynamics that regulate the relationship between architecture and graphic representation. The critical description of architecture, starting from the graphic reading of the typological imprints of the constructions of the past and the morphological configurations, with reference to the discipline of drawing, makes explicit the awareness of the scientific and cultural foundations of representation methods aimed at understanding architecture.

The photogrammetric image of the Monasteries

For the digital restitution of the Monastery of the Spring Fountain on the island of Poros, the Monastery of the Assumption of the Virgin Mary on the island of Hydra and the Monastery of St. Nicholas in Spetses, photogrammetry plays a role of considerable interest, as the images taken from digital cameras contain the information for the realization of models, the campaign is quick and reduced to the shooting of photographic images often at low cost. As is well known, photogrammetry is the science that allows to obtain accurate measurements from photographs by transforming two-dimensional information into three-dimensional measurements [Manfredini, Remondino, 2010].

Photogrammetry, therefore, in the context of this applied research, has the task of establishing a graphic and geometric relationship between the images taken on site and the object of survey in a photographic shot. The photogrammetric technique allows, therefore, to determine technical information to make metric measurements on the size, shape and position of the object starting from measurements taken on images taken from both fixed and mobile supports.

It is useful, for this research, to mention the field of passive optical sensors, as instruments such as cameras that are used to capture the reflection of natural light on the surface of the object to be detected and, if at least two images with two different points of view are used, they trigger a stereoscopic vision of a surveying object similarly to what happens in human vision.

Conclusion

The contribution, through manual and instrumental surveys, outlines the architectural features of the Monastery of the Spring Fountain on the island of Poros, the Monastery of the Assumption of the Virgin Mary on the island of Hydra and the Monastery

of St. Nicholas in Spetses. These structures were erected between the mid-seventeenth century and the second half of the following century, of which few documents remain of their original spatial configuration in the context of the places, proposing, today, interesting perceptions, research and analysis. Even the urban or natural environment that surrounds them remains full of charm, with visions of the city and the sea from the chosen settlement in an emerging position with respect to the cities.

The progress of the research can be identified in the methodologies used and in the experimentation among the various instruments in possession. The use of interactive software for graphic restitution, digital representation and 3D modeling has allowed the knowledge of the current aspects, of the uses that attest their past function. The determination of a scientific procedure, usable on other architectural artefacts, has determined a further element of the research.

References

- [1] AA.VV. (2004) - *Spetses*. Atene: Micheal Toubis Publication.
- [2] AA.VV. (2014) - *Holy Monastery of the life - Giving Spring*. Poros: Monastery press.
- [3] Amoruso, G., Apollonio, F., I., Remondino, F. (2010) - *Caratterizzazione strumentale di sensori attivi a tempo di volo e a triangolazione. Utilizzo di laser scanner su superfici marmoree di epoca romana*, Scuola Normale di Pisa.
- [4] Apollonio, F., I. (2010) - *La modellazione digitale*, Bologna, Clueb.
- [5] Barba, S., Cardone, V. (2013) - *Modelli grafici dell'architettura e del territorio*, Santarcangelo di Romagna, Maggioli.
- [6] Bertocci S. & Bini M. (2012) - *Manuale di rilievo architettonico urbano*. Torino: Città studi edizioni.
- [7] Bianchini, C. (2011) - *Rilievo Modellazione e Studio Geometrico delle Cupole*, Roma, Edizioni PreProgetti.
- [8] Brusaporci, S. (2007) - *Modelli interpretativi dell'architettura medievale*, L'Aquila, Arkhè.
- [9] Capone M. (2012) - *Geometria per l'Architettura*. Napoli: Giannini Editore.
- [10] Corniello, L. (2019) - *3D surveying and 3D reconstruction of architecture of the Royal Park of Tirana*. The International Archives of the Photogrammetry, Remote Sensing and Spatial Information Sciences, XLII-4/W18, 241–246, 2019
- [11] Guter, J. (2008) - *I monasteri cristiani*. Roma: Edizioni Arkeios.
- [12] Loudon M. (2018) - *Hydra. An Island and its architecture*. Vienna: Phoibos Verlag.
- [13] Manfredini, A., M., Remondino, F. (2010) - *Modellazione 3D da immagini. Pipeline fotogrammetrica*, Scuola Normale di Pisa.
- [14] Messina B. (2012) - *The domes of the Amalfi Coast: survey and digital representation of complex shapes*. Firenze: Nardini Editore.

ARCHEOLOGICAL FINDINGS OF ANCIENT HARBOR IN THE PILOT SITE OF INTERREG ADRION APPRODI PROJECT IN ORTONA (CH, ABRUZZO), CENTRAL ADRIATIC SEA

Maria Carla de Francesco¹, Mauro Zappalorto¹, Diana de Francesco¹,
Massimo Mangifesta¹, Angela Faraone¹, Maurizio Paluzzi¹, Claudia Minciarelli¹,
Giulio Tatasciore¹, Andrea R. Natale¹

¹Comune di Ortona – Via Cavour, 24 66026 - Ortona (CH),
phone+39347 0781143, e-mail: maria.defrancesco@unimol.it

Abstract – The Interreg Adrion ‘APPRODI’ project aims at a qualitative change in the nature of tourism demand with a transnational approach and at increasing visibility of the valorized new destinations. The geological and archaeological investigations, both at sea and on the coast, aim to broaden the territory’s knowledge by realization of a geo-archaeological map, even underwater, with the indication of archaeological finds and a reconstruction of the marine traffics of the Ortonese navy within the main routes in the Mediterranean Sea. Moreover, the project will allow to create the conditions for development of cultural tourism, even underwater, increasing and enhancing the historical and archaeological resources.

In the sea in front of Ferruccio Cape, except the presence of rocks with various size due to landslides for a length of about eighty / one hundred meters from the current coastline, was found a set of wooden planks lying between the rocks, at a distance that varies from four to ten meters from the coastline, to belong to the plating of a boat or to a warf collapsed into the water.

In front of the Ortona promontory was found a glazed ceramic tube of the type of those inserted in the walls and used to channel rainwater.

The Interreg Adrion APPRODI project results will allow to increase visibility and to valorize new destinations enhancing the maritime and coastal heritage.

Introduction

Until the 9th century BC through the middle-Adriatic way, new Indo-European populations arrived in Ortona (at present in Abruzzo region), settling on the castle hill and merging with the existing population. The *epineion*, referring to the ‘Seaport’, has been named for the first time by Strabo (60 BC-20 AD) which reported the presence of "*Hortòn épineion frentanòn*" (Ortona harbour of the Frentani people); this harbour, located with piers and docks, was not a simple natural landing where the naval arsenal was housed, but a place of shelter for the boats that had made Ortona known for its expert builders. The ancient harbour was situated in the location called Lo Scalo (the Seaport) in the North of the Aragonese castle, between Ferruccio Cape-Punta Lunga Cape and Mouth of the Peticcio river-Lighthouse (Figure 1). [5, 6, 7, 15].

During the Norman-Swabian period (1080-1268 AD), the port activity was so increased as to be reported in the *Capitulare di Bajulazione* (1196 AD), a document that regulated the commercial activities of the port of Ortona [20, 21, and 22].



Figure 1 - Location of Interreg ADRION APPRODI in Ortona Municipality.

In the 11th century on the Abruzzo coast there were shipping companies and businesses serving mercantile trade, which developed in particular towards the Dalmatian coast: the establishment of the Venice-Ancona-Ortona-Slavonia network (State Archives of Venice) is referred in a document of 1200 AD. In the Seaport, current La Ritorna beach (Figure 1), it is possible to identify the traces of the ancient port's pier, composed of six rows of stone blocks, built according to the ancient technique of the *opus quadratum*, with the root of the old pier divided into three parts (Figure 2). [7, 8, 12, 18, 19].

During the Byzantine domination, Ortona became an important centre and the Venetian raid (1447 AD, June 30th) contributed to the decision to strengthen the harbour of Ortona and to move it to the southern, equipping it with advanced defensive structure extending the dock on the northern side, similarly to the present shape. During the 16th and 17th centuries, Ortona, after being purchased by Margaret of Austria (daughter of Charles V) on 1582, enjoyed of a relative stability on the economic and socio-political levels, thriving mostly through the salt trade and the construction of ships. [8, 11, 12, 18, 19].



Figure 2 - Pier of ancient harbour at ‘Lo Scalo’ locality in Ortona.

Even in the Bonapartist period of the French decade, under the kingdoms of Joseph Bonaparte first and Joachim Murat then, the site was affected by war episodes, in particular by the cannoning of the port in 1811 by the English fleet [13].

Unharmful after the Great War, during the Second World War Ortona represented the Adriatic side of the Gustav line, and precisely from the harbor of Ortona the royal Savoy family, fleeing from the Nazi occupation, escaped during the night of September 9th-10th, 1943. After the war, the harbor repeatedly underwent works of consolidation and modernization, turning it into one of the most important seaports of Abruzzo region. [10].

Materials and Methods

The Interreg Adrion ‘APPRODI’ project aims at a qualitative change in the nature of tourism demand with a transnational approach and at increasing new destinations visibility. The geological and archaeological investigations, both at sea and on the coast, aim to broaden the territory’s knowledge by realization of a geo-archaeological map, even underwater, with the indication of archaeological finds and a reconstruction of the marine traffics of the Ortona navy within the main routes in the Mediterranean Sea. Moreover, the project will allow to create the conditions for development of cultural tourism, even underwater, increasing and enhancing the historical and archaeological resources through the institution of archeological Museum in Ortona (coast of Abruzzo region, Italy) to host the ancient port findings.

The APPRODI project in Ortona includes the following target areas (Figure 1):

- the marine area of Punta Ferruccio and San Marco, in the north side of the Ortona coast, inside to the Regional Naturalistic Reserve Ripari di Giobbe;
- the marine area in front of the beach named ‘La Ritorna’, close to north port pier;
- the marine area includes of Punta Acquabella and the Mouth of Moro river, in the south side of the Ortona coast, inside to the Regional Naturalistic Reserve Punta dell’Acquabella.

Ortona landscape develops parallel to the coastline and rests on a plateau of Pleistocene sediments creating hills that form a high cliffs’ series overlooking the sea. The reefs overlap to sea reach 40 ÷ 70 meters in high, with a very interesting sedimentological features but subject to landslides typical of the area, with consequent cliffs erosion and shoreline changing. Near the mouths of rivers and according to storm surges occurs constantly shaping the coastline [2,3].

Ortona, where there are two Regional Natural Reserves, is inserted in the eastern most part of the hills of the Abruzzo Apennines. The stratigraphics of the coastal strip is the result of erosion and sedimentation processes that followed one another over time. In the top of the succession there are sands with typical structures of sedimentation environment (submerged beaches and the gravelly bodies of fluvial environment). This area is characterized by sands, silty sands, conglomerates and clays, typical of the Mutignano Formation (Pleistocene 0,012 - 2,58 Ma). [14].

The study of the area is implemented with detailed morphometric analyzes to improve the description of the coastline at low depths [1]. The geomorphological data were filtered and interpolated in order to reconstruct the whole evolution of the Adriatic coast of interest with a good approximation [17]. The analyzes will be further integrated by calculating the exposure of the slopes (Aspect), i.e. the orientation of the direction of maximum slope of a surface, quantified by the angle (on the horizontal plane) that the line of maximum slope for a cell of a DEM (Digital Environment Model) form with the geographic North, measured in clockwise. The geomorphological cartography with depth scale obtained by morphometric analysis of the area target seabed is shown in the Figure 3.

The analysis of seabed depth was used to plan the dive surveys in the areas target of Interreg APPRODI project.

The dive sampling was accompanied by photographic documentation of the archaeological finds on the seabed to better structure a cultural and archeological map for touristic valorization. For each site were performed 5 dive samplings (for a total of 15 samplings)

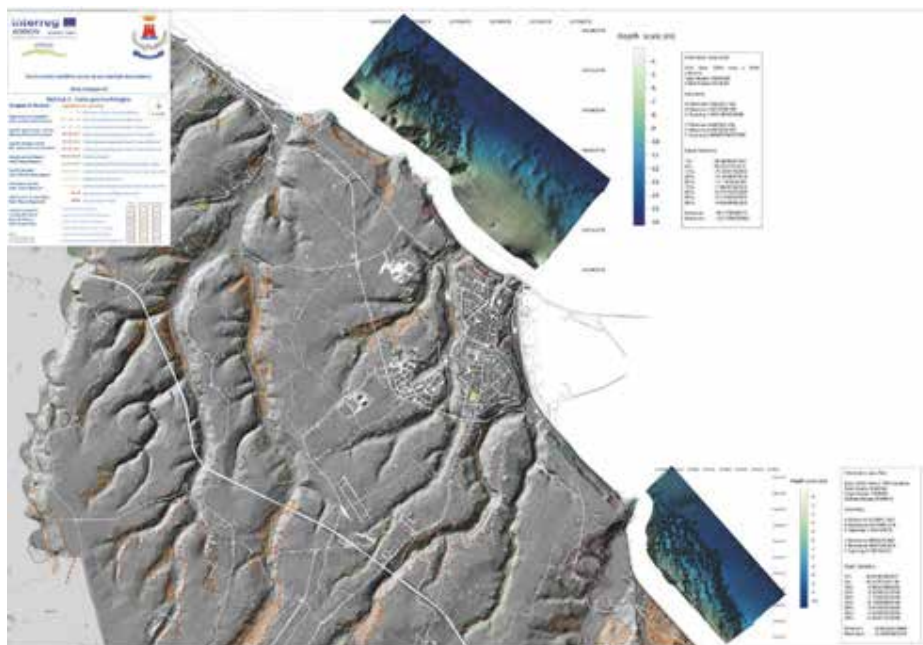

Figure 3 - Geomorphological cartography with depth scale.

where the operator has viewed the seabed up to 300 meters from the coast (at a maximum depth of -12 m) to find and geo-reference the archaeological finds.

Results

The archeological heritage found on the seabed on Ortona Municipality includes findings from various historical periods. The anthropic activities (i.e. realization of modern harbor) and the landslides of the hill partially buried the archaeological finds in depth, however very interesting remains were found.

In the North side of the coast, in the sea in front of Torre Mucchia are presents numerous rocky blocks due to landslides of the promontory over the centuries, with the remains of some metal poles emerging from the bottom for a few tens of centimeters, attributable to the piling of a Trabocco, a local typical fishery machine (Figure 4, 5). The presence of the Trabocchi along the Abruzzo coast is proved since 1700 AD [16].



Figure 4 - Rests of the piling of a Trabocco, typical fishery machine.



Figure 5 - Trabocco, a typical fishery machine along the Abruzzo and Molise coasts.

In the Ferruccio cape, except the presence of rocks with various size due to landslides for a length of about 80÷100 meters from the current coastline, was found a set of wooden planks lying between the rocks, at a distance that varies from 4 to 10 meters from the coastline, to belong to the plating of a boat or to a wharf collapsed into the water (Figure 6).



Figure 6 - Wood material from a boat or a wharf (Ferruccio Cape, Regional Natural Reserve of Ripari di Giobbe).

In front of Ortona Promontory, in the external side of breakwaters and wave barriers, until 34÷40 meters and a depth of 5 to 7 meters, the seabed is characterized by river pebbles and big rocky blocks due to landslides of the promontory. The discovery of a glazed ceramic tube of the type of those inserted in the walls and used to channel rainwater, would allow us to interpret the layer of river pebbles as a collapse of portions of the castle or other buildings built on the promontory above (Figure 7).

The internal site of breakwaters and wave barriers is characterized by a low and sandy seaside with a depth of 2÷3 meters, from where sprout large blocks of rock due to the landslides that characterized the castle promontory.



Figure 7 - Archeological finding of a glazed ceramic tube used to channel rainwater.

Conclusion

The Interreg Adrion APPRODI allowed the municipality of Ortona to analyze the archaeological heritage present in the proximal seabeds of the shoreline and to prepare a descriptive underwater itineraries of the areas identified of the projects [9]. Furthermore, the main merchant routes of the Ortona naval traffic have been reconstructed with the creation of a photographic and video catalog.

Now the archeological findings are integrated into the natural context, placed between 5 and 15 meters deep and above marine habitats, with an appreciable floro-fauna

coverage [4]. Moreover, the seabed presents several important geologic formations that show the modification of coastline during the centuries.

The main challenge of the project is developing an Integrated Cultural, Geologic/Naturalistic and Touristic map that describes in the same context the principal archeological/cultural, geologic and naturalistic sites in the marine environment of Ortona coast.

This project represents a first step of characterization of archeological and cultural heritage present in the marine-terrestrial naturalistic areas for a valorization strategy. Further analyses are need to find the remains buried at greater depths and perimeter the archaeological areas for a better conservation.



Figure 8 - Integrated Cultural, Geologic/Naturalistic and Touristic map.

Acknowledgments

Thanks to the municipality of Ortona for participation in the project and availability during the search for sources. A big thank you to Dr. Barbara Napoliello and Dr. Tito Vezio Viola of Ortona Municipality for professionalism and help in carrying out the project actions. In addition, thanks to ARTA Abruzzo for the support during the analysis of the bathymetry and the geomorphology of the seabed.

References

- [1] Calista M., Di Giandomenico B., Mangifesta M. (2007) - *Modellazione numerica finalizzata allo studio del comportamento meccanico delle terre: applicazioni 3D per l'analisi della stabilità dell'area orientale dell'abitato di Ortona (CH)*. *Giornale di Geologia Applicata* 6 (2007) 81-91, doi: 10.1474/GGA.2007-06.0-08.0190.
- [2] CNR (1985) – *Atlante delle spiagge italiane*, Firenze.
- [3] Colantoni P, Mencucci D, Nesci O (2004) – *Coastal processes and cliff recession between Gabicce and Pesaro (northern Adriatic Sea): a case history*. *Geomorphology* 62(3-4): 257-268.
- [4] de Francesco M.C., Cerrano C., Pica D., D'Onofrio D., Stanisci A. (2017) – *Characterization of Teatina Coast Marine Habitats (Central Adriatic Sea) toward an Integrated Coastal Management*. *OFOAJ*, 5 DOI: 10.19080/OFOAM.2017.05.555653.
- [5] De Luca T. (1979) – *Pagine di storia frentana e di Ortona antica*, Ortona.
- [6] De Luca T. (1986) – *Ortona. Note di archeologia, storia ed arte*, Pescara.
- [7] Falcone A. (2004) – *Storia di Ortona*, Ortona.
- [8] Falcone A., Iubatti N. (1980) – *Ortona: itinerario turistico culturale*, Ortona.
- [9] Felice C. (1983) – *Porti e scafi. Politica ed economia sul litorale abruzzese-molisano*, Vasto.
- [10] Giannelli E., Iubatti N., Pacaccio D. (1983) – *La battaglia di Ortona. Momenti di una tragedia, 1943-1944*, Pescara.
- [11] Iubatti N., Di Lullo P. (1987) – *Ortona e i traffici marittimi dal XII al XVII secolo*, Ortona.
- [12] Landini P. (1972) – *L'evoluzione delle attività portuali di Ortona*, *Rivista Geografica Italiana*, 79, 156-184.
- [13] Nardone P. (2008) – *Portualità e navigazione in Abruzzo nella prima metà del XIX secolo*, Bari.
- [14] Ori G.G., Rusciadelli G. – *Note illustrative (Progetto CARG) Foglio geologico 351 (Pescara) alla scala 1:50000*
- [15] Orlandi M. L. (1999) – *Mappa archeologica del territorio di Ortona. Ortona romana*, *Giornale Storico Ortonese*, 10.
- [16] Orlando E. (2001) – *La costa dei Trabocchi*, Pescara
- [17] Palmieri E.L., Centamore E., Ciccacci S., D'Alessandro L. Del Monte M., Fredi P., Pugliese F. (1998) – *Geomorfologia quantitativa e morfodinamica del territorio abruzzese. II. Il bacino idrografico del Fiume Tordino*. *Geografia Fisica e Dinamica Quaternaria* 21:113-129
- [18] Recchini F. P. (1909) – *Appunti cronologici per la storia di Ortona-mare*, Ortona a Mare.

- [19] Romanelli D. (1809) – *Scoperie patrie di città distrutte, e di altre antichità nella regione frentana [et...]*. Napoli.
- [20] Staffa A. R. (2002) – *L'Abruzzo costiero. Viabilità, insediamenti, strutture portuali ed assetto del territorio fra Antichità e Alto Medioevo*, Lanciano.
- [21] Staffa A.R. (2004) – *Ortona fra tarda antichità ed altomedioevo. Un contributo alla ricostruzione della frontiera bizantina in Abruzzo*, *Archeologia medievale*, 31, 365-403.
- [22] Staffa A.R. (2006) – *I centri urbani dell'Abruzzo adriatico fra tarda antichità e altomedioevo*, Firenze.

IL PARCO ARCHEOLOGICO DI SATURO (LEPORANO-TA) MILLENNI DI STORIA, DECENNI DI INCURIA

Fabio Fabrizio

Università del Salento – Dip. di Beni Culturali, via Birago 64 - 73100 Lecce (Italy)

phone +39 0832 295515, e-mail: fabio.fabrizio@unisalento.it

Abstract – Alongside the Ionian Coast, on a promontory between two harbours and about to 12 km SE from Taranto, there is the ancient settlement of Satyrion, one of the most significant places in the Mediterranean. Situated in a privileged geomorphologic position, between two creeks, protected from the winds and rich in water springs, the site had been inhabited from the Neolithic to the high Middle Age.

The very name of the place poses great emphasis on its chronological phases and on the diachronic relationship with Taranto. Presence of ancient structures in the area was well known since 1700, but systematic excavations were carried on only after the half of the XX century. In 1959 F.G. Lo Porto found a holy area dedicated to the nymph Satyria. The first period of this site dates back to the second half of the VII century b.C. and used to the first years of the II century b.C. In the first years of the 1900, the proto-historic site was found on the relief in front of Porto Perone bay, and the excavations permitted to study the several types of huts referred to different phases, since the middle Bronze Age.

From the archaic age to the Hellenistic age, the higher part of the hill had been used as holy area, probably dedicated to Athena. Around the II century b.C., remains of a structure in front of the sea would later be used as a harbour. Above them, during the years of Augustus, the plateau was occupied by a big villa used up to the V century b.C. The importance of this site is underlined by the establishment of the Parco Archeologico di Saturo which, for a long time, hasn't been adequately protected and promoted, the latter being useful for the development of the area.

The only valuable intervention took place at the end of the XX century, when the archaeological area between Porto Perone and Porto Saturo was subject to restoration, promotion and fruition works. The projects had the goal to realize interventions for the touristic promotion in the historical and cultural areas of the Magna Grecia, in the field of the Multiregional Operational Program. The Archeological Park projects activation began in 1997. The paths involved the plain part of the promontory, bathed on three sides by the sea and characterized by the remains of a Roman villa, and the NE area, the acropolis, with remains of the Iron and Bronze Age. The area of the Parco Archeologico di Saturo had only been usable for a few years, then collapsing in a terrible abandonment situation. Only in 2006, the area began to develop new interest. Between 2012 and 2013, a financing by the Regione Puglia gave the possibility to begin a project dedicated to youngsters called “Arkeogiochi”. For more than a year, the area of Saturo has been placed under the financing channel called “Polo Museale di Taranto”.

Inquadramento geografico e storico dell'area

Lungo la costa ionica, su di un promontorio di forma trapezoidale orientato NE-SO, lungo circa 420 m e largo 200 m, fra due baie (Porto Perone a est e Porto Saturo a ovest) e a circa 12 km SE di Taranto, vi è l'antico insediamento di Satyrion, uno dei luoghi più significativi del Mediterraneo. Posto in una posizione geomorfologicamente privilegiata, il promontorio è caratterizzato da un'altura posta a nord, orientata NNO-SSE, a 25 m s.l.m., lunga 50 m e larga 25 m, che separa le due insenature. La posizione topografica in rapporto al territorio agricolo, la naturale conformazione delle insenature e la presenza di una ricca sorgente, ha favorito l'insediamento umano a partire dal Neolitico sino all'Alto Medioevo [6].



Figura 1 - Veduta aerea del promontorio di Saturo (foto di M. Guaitoli, 2009).

Figure 1 - Aerial view of the Saturo promontory (photo by M. Guaitoli, 2009).

Storicamente le due insenature sono state interpretate come due luoghi di approdo distinti ma, attraverso indagini bibliografiche e topografiche, si è giunti alla conclusione che in antico esistesse una insenatura settentrionale di notevoli dimensioni (quella di Saturo), particolarmente riparata e che incideva profondamente il profilo della costa ed un'altra insenatura (porto Perone) più piccola e meno protetta [7]. Oggi quella parte di costa è quasi completamente antropizzata ma, dagli apporti alluvionali visibili in alcuni tagli effettuati per l'urbanizzazione, molto spesso abusiva, che sta invadendo e distruggendo i depositi archeologici e la costa, resta ancora individuabile. La stessa è, inoltre, visibile sulle carte geologiche [13] e soprattutto dalla lettura di fotografie aeree riprese in epoche diverse.

A parte la presenza di una torre costiera del XVI sec. e un bunker militare della seconda guerra mondiale¹, sul promontorio tra Porto Perone e Porto Saturno possono essere individuate le seguenti quattro zone archeologiche (fig. 2):

- 1 - l'abitato dell'età del Bronzo
- 2 - il santuario dell'Acropoli
- 3 - la villa romana
- 4 - il santuario della sorgente



Figura 2 - Indicazione delle aree presenti all'interno del Parco. (Foto S. Nistri).
Figure 2 - Indication of areas in the park. (Photo S. Nistri).

¹ Quest'ultimo ha causato notevoli danni alla sottostante stratigrafia durante la sua costruzione.

L'abitato dell'età del Bronzo (la c.d. Acropoli)

Si trova ad est rispetto all'insenatura di Porto Saturo, su un piccolo promontorio che attualmente è sottoposto a vincolo archeologico e paesaggistico.



Figura 3 - Veduta aerea della c.d. Acropoli e del Santuario arcaico (foto di M. Guaitoli, 2009).

Figure 3 - Aerial view of the Acropolis and the archaic sanctuary

Nei primi anni del '900, con la direzione di Quintino Quagliati, furono effettuati i primi saggi e i primi scavi archeologico-stratigrafici dell'area; dopo alcuni anni di pausa fu Felice Gino Lo Porto, nel 1958, a riprendere i lavori sistematici. La fascia ionica presa in esame si caratterizza di una costa bassa e rocciosa intervallata da piccole insenature sabbiose; dagli scavi effettuati si dedusse che l'area fosse popolata già dal IV millennio a.C., tuttavia le tracce dell'occupazione preistorica e quelle immediatamente precedenti la colonizzazione greca oggi non sono più visibili in quanto, per garantirne la conservazione, furono reinterati [3].

Dopo l'abbandono delle stazioni neolitiche della piana superiore, il promontorio tra le due baie risulta occupato soltanto nel II millennio (intorno al 1800 a.C.), verosimilmente con una concentrazione antropica prossima a Porto Saturo. Tale insediamento è inquadrabile alla prima età del Bronzo e precisamente nella fase denominata proto-appenninico B, inquadrabile intorno al 1800-1700 a.C. [5].

Attraverso lo studio degli insediamenti e della planimetria delle capanne individuate, si può supporre che l'occupazione continui nella fase successiva, caratterizzata dalla presenza nel sito di una comunità in costanti rapporti con il mondo egeo. La zona di Porto Perone, però, tra il XV e il XIV sec. a.C., vive una lunga fase di abbandono, documentata da uno strato di terreno sterile. Tale abbandono è certamente da mettere in relazione col carattere nomade delle

comunità pastorali appenniniche [2]. Nel XIII sec a.C., all'inizio della fase tardo-appenninica, il villaggio viene ricostruito; l'elemento distintivo di tale ricostruzione è l'innalzamento di un muro, cosiddetto ad aggere, che aveva funzione sia di difesa sia di contenimento del terreno contro eventuali frane sul lato orientale scosceso della collina. Esternamente, il muro difensivo, presentava un ampio canale a pareti curvilinee, verosimilmente per il drenaggio delle acque meteoriche verso il mare, collegato ad un altro muro parallelo alla struttura principale. Le indagini archeologiche condotte dal Lo Porto portarono all'individuazione di alcune buche di palo delle abitazioni del nuovo villaggio, consentendo di ricostruire un modello insediativo caratterizzato da ambienti sub-circolari, le cui pareti dovevano essere costruite con intreccio di canne e foglie rivestite di intonaco argilloso.

Il santuario dell'Acropoli

I primi scavi effettuati in quest'area furono condotti dal Lo Porto nel 1964 e, dopo un periodo di pausa, furono ripresi, nel 1974, da Ettore M. De Juliis. L'area di indagine è situata a sud-est rispetto ai rinvenimenti dell'età del Bronzo, in una posizione centrale rispetto alle due insenature.

Il Lo Porto, dalle tracce archeologiche rinvenute, dichiarò che, con molta probabilità, intorno alla metà del IV sec. a.C. esistesse, tra le baie di Porto Perone e Porto Saturo, un santuario; trattasi di una struttura in opera quadrata, un *temenos* o forse un sacello, nell'area di un più antico *oikos* costruito in materiale deperibile (fig.4).

Ai piedi della struttura in opera quadrata è stata individuata una favissa, piccola cisterna utilizzata per la deposizione di oggetti votivi arcaici (miniaturistici); essa si presentava esternamente rivestita da lastre tufacee squadrate, parallele al muro stesso e occultata sotto un lastricato in funzione del nuovo assetto del santuario [9].

Il materiale di questa stipe primaria, riferita quindi al rituale del culto più antico sull'acropoli di Satyrion, è cronologicamente compreso tra la metà del VII e l'inizio del



Figura 4 - Resti di strutture del sacello arcaico.

Figure 4 - Remains of structures of the archaic sacellum.

VI sec. a.C.; la ceramica maggiormente ritrovata è di tipo protocorinzio e corinzio antico, oltre che figura insieme alle terrecotte votive di produzione locale o più probabilmente tarantina.

Nella stratigrafia superiore dello scavo, invece, furono recuperate statuette votive, come quelle della zona denominata Pizzone [11] databili alla seconda metà del VI sec. a.C., che hanno suggerito di attribuire il santuario al culto di Persephone/Kora, introdotto dai primi coloni laconici a Satyrion come a Taranto [3].

La villa romana

La Villa Romana si estende lungo i due lati del promontorio, affacciandosi ad est sull'insenatura di Porto Perone e ad ovest su quella di Porto Saturo (fig. 5).

Le prime indagini archeologiche della villa ebbero inizio nel 1941 sotto la direzione di Ciro Drago, ma anche in questo caso, subito dopo, l'area fu abbandonata per molti anni. Fu parzialmente recuperata, nel 1969, con alcuni lavori di consolidamento e restauro del sito condotti da Elena Lattanzi e, successivamente, negli anni 80 con le opere di bonifica e tutela coordinate da Arcangelo Alessio.

Gli scavi hanno messo in luce i resti di una villa romana che domina le due insenature. Dagli studi effettuati dallo stesso C. Drago furono individuate due aree distinte che fanno riferimento alla costruzione di epoca romana, ma, verosimilmente, è possibile che si tratti di un unico complesso edilizio che si estendeva da un porticciolo all'altro, collegato sul lato del mare da un portico in opera incerta [3]. Tra le due aree edificate di epoca romana, insiste una Torre Costiera del XVI sec.; ad est di quest'ultima, in seguito agli scavi di E. Lattanzi nel 1969, veniva individuata la pars rustica della villa.



Figura 5 - Veduta aerea della villa romana (foto di M. Guaitoli, 2009).

Figure 5 - Aerial view of the Roman villa (photo by M. Guaitoli, 2009).

Gli scavi hanno permesso di mettere in luce una grande cisterna con volta a botte e pareti impermeabilizzate con intonaco, un ambiente con vasca (probabilmente rivestita con marmi bianchi) e canalizzazione in tubi di terracotta affiancate ad un piccolo impianto termale ed una serie di ambienti domestico-residenziali con pavimenti a mosaico policromo. Tali ambienti si affacciano su un atrio tetrastilo di ordine dorico, al centro del quale è stato rinvenuto, durante l'ultima campagna di scavi, un *impluvium* per la raccolta delle acque e i relativi sistemi di drenaggio; sul lato opposto dell'atrio vi sono tre piccoli ambienti pavimentati in tessellato di argilla, oggi quasi del tutto asportato.

La struttura prossima all'insenatura di Porto Saturo, invece, è composta da un ampio complesso termale della villa; di questo fanno parte una grande vasca originariamente rivestita di marmi bianchi asiatici, probabilmente una piscina, fornita di un sistema di riscaldamento ad ipocausto funzionale ad un contenitore metallico posto al centro della struttura e che trasmettendo calore riscaldava l'acqua. Accanto alla piscina sono stati individuati il *tepidarium*, vasto ambiente destinato alla circolazione dell'aria calda, il *praefurnium*, per l'immissione del combustibile necessario a produrre calore e un altro ambiente rettangolare su cui affacciano due piccoli vani interpretati come spogliatoi.

Nel settore più orientale, quello prossimo alla torre costiera, è stato rinvenuto un esteso ambiente triabsidato con resti di pavimento in marmo, probabilmente una sala destinata ai banchetti. Le strutture hanno rivelato rifacimenti e fasi costruttive distinte, ricollegate da E. Lattanzi ad ambiti cronologici diversi; i resti attualmente visibili risalgono al III sec. d.C., con continuità di uso fino ad età tardoantica, mentre l'impianto originario della villa va riferito alla prima età imperiale [3].

Il santuario della Sorgente

Il cosiddetto Santuario della Sorgente si trova circa 900 m a nord del promontorio di Saturo, tra l'attuale strada litoranea ed il mare, all'interno di una lieve depressione naturale dove scorreva un ruscello che aveva origine da una sorgente di acqua dolce.

Secondo gli studi condotti dal Lo Porto, nella sua fase iniziale, il santuario fu dedicato alla ninfa Satyria (madre di Falanto), per poi passare, successivamente, alla divinità principale, probabilmente una dea Basilis citata in un'incisione sull'orlo di un'anfora attica a figure nere datata al VI sec. a.C.

Alcune fonti fanno pensare ad Afrodite guerriera e regina dell'acropoli di Sparta ma è attestata anche la presenza di Gaia, divinità ctonia, connessa alla fertilità della terra e degli uomini (tale epiteto è inciso sotto il piede di uno skyphos del VI sec. a.C.). Dunque una connotazione femminile del santuario forse collegata a riti di passaggio delle giovani donne che si avvicinavano al matrimonio e alla procreazione.

Tali indagini archeologiche furono effettuate dal Lo Porto tra gli anni 1973 e 1977. Sfortunatamente, le attività di scavo clandestino hanno pesantemente modificato l'intera area, abbattendo quasi la totalità delle strutture messe in luce e favorendo, inoltre, l'immissione nel mercato illegale dei numerosi reperti provenienti dall'area del santuario tarantino.

L'idea del Parco Archeologico

Per circa un ventennio (tra gli anni '70 e '90 del 900), nonostante l'indiscutibile

importanza archeologica di Porto Saturo, l'area è stata completamente abbandonata e consegnata, di fatto, in mano ai vandali e ai tombaroli.

L'unico progetto di valorizzazione risale alla fine degli anni novanta quando l'area in questione ottenne dei finanziamenti per opere di ristrutturazione, valorizzazione e fruizione; ma anche in questo caso, a causa dell'incuria degli organi di controllo e gestione, gli interventi risultarono vani. Tali opere rientravano nelle iniziative finalizzate alla realizzazione di interventi di valorizzazione turistica nelle aree storico culturali della Magna Grecia, nell'ambito del Programma Operativo Multiregionale (P.O.M.), regolato dal decreto 20 settembre 1996 del Dipartimento turismo della Presidenza del Consiglio ed approvato dalla Commissione Europea, che ha provveduto ai relativi finanziamenti.

Ma si consolidava l'idea, nonché l'esigenza, di realizzare un vero e proprio Parco Archeologico "dotato di tutte le infrastrutture necessarie, affinché accanto ad una struttura museale nascesse anche un punto di ritrovo accademico con relativa sala convegni multimediale che, con specifico regime di tutela:

- salvaguardasse l'integrità fisica ed esaltasse la fruizione dei beni;
- definisse le eventuali modificazioni fisiche e di uso compatibili con la salvaguardia;
- incentivasse le attività, tradizionali ed innovative che, in coerenza con la salvaguardia, determinassero lo sviluppo socio-economico della comunità residente".

Il Parco Archeologico di Saturo, quindi, fu diviso in due zone naturalmente caratterizzate dall'orografia del terreno: l'area a SUD, con i resti del complesso edilizio di epoca romana e impreziosita dalla presenza della torre costiera, notevole punto panoramico e di vista sull'intera area e l'area a NORD, con andamento digradante verso il mare, caratterizzata da alcune zone pianeggianti di grande interesse scientifico, alle pendici del promontorio, su cui furono posti in luce, e successivamente ricoperti, resti di età del bronzo e di età successive, con continuità di presenza.

Strutturazione e storia del Parco

Nel 1997 il Comune di Leporano (Ta), area in cui insiste l'area di Saturo, riuscì ad ottenere i finanziamenti statali per la realizzazione del Parco Archeologico

"La struttura Parco era costituita da un insieme di aree funzionali, il cui connettivo era rappresentato dai percorsi di visita che si sviluppavano con andamento sinuoso, nel rispetto dell'aspetto orografico del terreno; gli stessi erano stati integrati da radure-spazi di sosta immersi nella macchia mediterranea".

A valle della cosiddetta acropoli fu organizzata un'ampia area pianeggiante per la realizzazione di un centro di accoglienza, sede di idonei spazi didattico-espositivi ed amministrativi e di una altrettanto estesa area verde con destinazione d'uso per manifestazioni culturali. L'area del complesso edilizio di epoca romana fu interessata da importanti lavori di restauro e consolidamento (nonché valorizzazione), con l'innalzamento di recinzioni metalliche e coperture dei resti archeologici corredati da una puntuale cartellonistica descrittiva del sito.

Ma, a causa della poca professionalità dei gestori, poco abili ad organizzare servizi di controllo, diurno e notturno, per la salvaguardia del sito, dopo soli tre anni il Parco Archeologico di Saturo cadde nuovamente in uno stato di completo abbandono.

Il Parco, sin dalla struttura d'ingresso, si presentava gravemente vandalizzato. Il

lungo e sinuoso percorso tra macchia mediterranea e aree archeologiche risultava, a causa dell'incuria e della crescita incontrollata della vegetazione, difficilmente rintracciabile; il centro accoglienza fu reso inagibile, privato di tutti gli infissi, interni ed esterni, e di tutte le attrezzature che erano presenti all'interno. Le aree adibite per gli incontri culturali abbandonate all'incuria, gli impianti di illuminazione e irrigazione sottratti dai vandali, le aree archeologiche, interessate negli anni '90 dai lavori di recupero, risultavano prive della copertura (in alcuni tratti anche della recinzione), e ricoperte anch'esse dalla vegetazione cresciuta in maniera incontrollata. Il Parco Archeologico di Saturo si stava imbattendo in una situazione di confuso assenteismo e di diffuso disinteresse, cadendo in un inaccettabile stato di degrado.

Solo nel 2005 il Parco Archeologico di Saturo vive la sua vera opera di recupero e di valorizzazione, quando la cooperativa di servizi per i Beni Culturali PoliSviluppo, composta da professionisti nel campo dell'archeologia, si aggiudicò la gestione temporanea dell'area archeologica. Nonostante il paradosso burocratico che ha visto impiegati investimenti economici di natura privata a servizio di un'area pubblica, iniziarono ad essere garantiti numerosi servizi di valorizzazione e fruizione inesistenti fino ad allora.



Figura 6 - Vista della *natatio publica* della villa romana prima (a) e dopo (b) gli interventi di recupero e valorizzazione del 2006.

Figure 6 - View of the publica natatio of the Roman villa, before (a)

Tra il 2006 e il 2018, anni di gestione (con rinnovo annuale) della Cooperativa Polisviluppo, il Parco Archeologico di Saturo è stato fruibile, in tutti i suoi 6 ettari, con numerosi servizi sempre più vicini alle esigenze del fruitore; un'area ristoro prospiciente il promontorio, servizi di guida turistica, visite guidate, mantenimento e valorizzazione dell'area ambientale e la messa in sicurezza delle zone oggetto di pericolo e di crollo.

Ma è tra gli anni 2012 e il 2013 che all'interno del Parco Archeologico di Saturo nasce uno dei progetti più innovativi del mezzogiorno d'Italia: il progetto di valorizzazione turistica "ArKeogiochi – Il Parco Giochi del Mondo Antico"; progetto inquadrato nel piano di "Sostegno alla gestione degli spazi pubblici per la creatività giovanile" della Regione Puglia. ArKeogiochi presentava ricostruzioni del mondo ludico-sportivo dell'antichità, tra scenografie (colonnati, templi, statue di divinità) che richiamano soprattutto il mondo dell'antica Grecia (fig. 7).



Figura 7 - Vista al tramonto di una statua di Zeus all'interno dell'Arkeogiochi di Saturo.
Figure 7 - Sunset view of a statue of Zeus inside the Arkeogiochi di Saturo.

Così il Parco Archeologico di Saturo è diventato nel giro di pochi anni un innovativo parco a tema, probabilmente unico a livello nazionale e internazionale, centro di archeologia sperimentale, laboratorio (Arkeolab) di ricostruzione ludico-didattica di giochi di varie epoche storiche (dalla preistoria all'età greca, romana e fino al medioevo), con giochi di ingegno e strategia, giochi di abilità manuale, giochi da tavolo in scala gigante. Gli è stato riconosciuto il diritto di essere inserito tra i Poli Museali d'Eccellenza del Mezzogiorno, riconoscimento che premia gli sforzi dell'investimento privato dei professionisti impegnati nell'opera di valorizzazione, facendo rientrare, peraltro, il territorio di Leporano tra le mete culturali più di interesse culturale a livello nazionale.

L'obiettivo, dunque, era ed è quello di favorire la valorizzazione delle aree di interesse storico-archeologico, contribuendo alla destagionalizzazione, incrementando le opportunità occupazionali ed economiche del territorio al fine di potenziare un indotto economico/culturale e commerciale. Unico strumento utile per il perseguimento di tali obiettivi deve essere il dialogo e l'interazione tra i diversi soggetti operanti nel mondo dell'archeologia, da un lato le Istituzioni e dall'altro operatori culturali e turistici.

L'incontro tra domanda e offerta rappresenta comunque uno dei punti di forza per la programmazione delle strategie di intervento sopracitate. In una fase storica come quella attuale, la strada da percorrere è quella della sintonia d'intenti tra le esigenze della conservazione e quelle della comunicazione, in un'ottica di recupero e valorizzazione finalizzata alla cittadinanza attiva e al riappropriamento di spazi pubblici abbandonati. Dalla primavera del 2019, però, il Parco Archeologico di Saturo è nuovamente chiuso al pubblico.

Dal 2018, infatti, è rientrato nella "Programmazione Strategica Nazionale e Comunitaria - Programmazione Europea e cofinanziamento nazionale - PON Cultura e Sviluppo 2014/2020" del MiBACT, ottenendo un finanziamento di 765000 € per le

attività di “Miglioramento fruitivo e conoscitivo del Parco Archeologico di Saturo (Leporano – Taranto)”. Sono previsti numerosi interventi volti a potenziare le condizioni attuali di offerta e fruizione attraverso lo sviluppo di un nuovo patrimonio digitale per la narrazione dell’area archeologica e per ampliare l’utenza, (anche disabile). Sono previsti nuovi percorsi multimediali, infopoint turistico presso la Torre Saturo per l’orientamento alla visita e l’informativa turistica, bookshop, sito web, grandi spettacoli e proiezioni con video mapping.

References

- [1] Becchetti S. (1897) - *L'antico acquedotto delle Acque Ninfali*. Tipografia fratelli Martucci, Taranto.
- [2] Biancofiore F. (1963) - *La civiltà micenea nell'Italia meridionale*. Edizioni dell'Ateneo, Roma.
- [3] De Luca F., Fabrizio F. (2015) - *L'insediamento di Satyrion – Saturo (Leporano - TA): dal mito alla storia, dall'abbandono al recupero*, in *Geologia dell'Ambiente – Supplemento 2*, pp. 117-122.
- [4] DeJuliis E.M. (1980) - *L'attività archeologica in Puglia*, in *Atti del Convegno di Studi sulla Magna Grecia, XX*, Arte Tipografica Editore, Taranto.
- [5] Dell'Aglio A. (1999) - *Il parco archeologico di Saturo Porto Perone, Leporano, Taranto*. Scorpione Editore, Taranto, pp. 46-49.
- [6] Guastella P. (2003) - *Saturo. Leporano, Taranto*, in *Lo Sguardo di Icaro. Le collezioni dell'Aerofototeca Nazionale per la conoscenza del territorio*. Campisano Editore, Roma.
- [7] Guaitoli M. (1997) - *Attività dell'Unità Operativa di Topografia Antica*. in *Metodologie di catalogazione dei beni archeologici. Beni archeologici – Conoscenza e tecnologie*, Quad. 1.2, Martano Editore, Lecce.
- [8] Lattanzi E. (1970) - *La villa di Saturo*, in *Atti del Convegno di Studi sulla Magna Grecia, X*, Arte Tipografica Editore, Taranto.
- [9] Lippolis E. (1995) - *La documentazione archeologica*, in Lippolis E., Garraffo S., Nafissi M., *Culti greci in Occidente, I*, Taranto, Editore Istituto per la storia e l'archeologia della Magna Grecia, Taranto, pp. 112-116.
- [10] Lippolis E., Marchetti C.M., Parisi V. (2014) - *Campagne di scavo 2007-2013*, in *Scienze dell'Antichità 20.1*, Edizioni Quasar, Roma.
- [11] Lo Porto F.G. (1963) - *Leporano. La stazione protostorica di Porto Perone*, «NSc». -Franco PancalloEditore, Locri.
- [12] Lo Porto F.G. (1964) - *Satyrion (Taranto). Scavi e ricerche nel luogo del più antico insediamento laconico in Puglia*, «NSc». Franco PancalloEditore, Locri.
- [13] Martinis B., Robba E. (1971) - *Note illustrative della Carta Geologica d'Italia, Scala 1:100.000, Foglio 202, Taranto*. Istituto Poligrafico e Zecca dello Stato, Roma.
- [14] Osanna M. (1992) - *Chorai coloniali da Taranto a Locri*. Istituto Poligrafico dello Stato, Roma.
- [15] Quagliati Q. (1936) - *La Puglia Preistorica*. Vecchi Editore, Trani.
- [16] Rellini U. (1941-42), *Scavi a Porto Perone presso Leporano (Taranto)*, «BPI», XIX-XX. Istituto Poligrafico e Zecca dello Stato Roma.

SAN CATALDO (LECCE, ITALY): THE HISTORICAL EVOLUTION OF THE COASTAL LANDSCAPE

Ivan Ferrari¹, Aurora Quarta²

¹ Institute of Heritage Science of the National Research Council (ISPC-CNR)
Prov.le Lecce-Monteroni, c/o Campus Universitario, 73100 Lecce (Italy), e-mail: ivan.ferrari@cnr.it

² Department of Cultural Heritage, University of Salento, Via Birago 64, 73100 Lecce (Italy),
e-mail: aurora.quarta@gmail.com

Abstract – San Cataldo (Lecce, Italy) is located on the Adriatic sea coast, about 10 km east from Lecce, in Apulia (Puglia) region. Since ancient times it was an important departure and landing place for trades and travels between the two shores of the Adriatic Sea. A clear evidence of it is the presence of a Roman pier, whose remains are currently partially visible. They were studied by recent multidisciplinary researches, outlining their technical-construction features and the ancient topography of the surrounding area.

Starting from the analysis of San Cataldo coastal landscape in ancient ages, this contribution is firstly focused to illustrate the evolution of the port in medieval times, when the resuming of long-haul commercial traffic led the port to be an important landing place for the Adriatic routes again. At this time, the old Roman pier was restored and protected by a coastal tower.

After a long period of abandon, the document analyses the transformations occurred between the 19th and 20th centuries, when it was built: a lighthouse, a new pier, close to the old one, a tramway. This ensured a fast connection between Lecce and its seashore. In the second half of the 20th century, a new tourist vocation finally replaced the commercial one for San Cataldo, leading to overbuilding events that characterise the current coastal landscape.

Introduction

San Cataldo (Lecce, Italy) is located along the Adriatic seaside, about 10 km east of Lecce: since ancient times has played an important role as a starting and landing point for trade and sea travels between the two shores of the Adriatic Sea (fig. 1). This document aims to illustrate the current coastal morphology, defining the changes occurred over time by natural events and anthropic action. The coastal landscape evolution is closely linked to Lecce history and to the appeal on its port by: construction of infrastructures, encouraging its use, enhancing the commercial and touristic role.

Materials and Methods

University of Salento “*Portus Lupiae*” project by Ancient Topography and Photogrammetry Laboratory (LabTAF), represents an important part on San Cataldo studies. The multidisciplinary researches of this project have been carried out in the area

surrounding the ancient Roman pier, assisted by bibliographic and archival investigation. Between 2004 and 2007, the results showed a detailed graphic documentation of the mainland remains of the pier (fig. 2), obtaining a better definition of the ancient construction technique and its peculiarities (thanks also to the lithological analysis of the building materials). The underwater surveys defined the extension of the submerged part of the pier, while topographical surveys were carried out in the portion of the territory, between the city of Lecce and San Cataldo, supported by aerial surveys with low-altitude flights [29]. Thanks to the collected data, it was possible to develop a photo interpretation study, integrated and compared with the recovery and analysis of the aerial historical pictures from the 1940s and 1950s. Furthermore, several geophysical prospections on the current Piazza Adriano, documented the extension of the pier structures below the road level, for a length of about 40 m [24].



Figure 1 - San Cataldo (Lecce, Italy): A) Aerial photo from southwest (LabTAF, 2013); B) Location in southern Italy.

Based on the results obtained in 2013, an archaeological excavation campaign was planned to light a new portion of the pier, 20 metres long near Piazza Adriano. Underwater cleaning operations on the opposite end revealed the last surviving line of the northern front wall for a length of about 70 metres.



Figure 2 -San Cataldo (Lecce, Italy): plan of the Roman pier ruins (by dr. Silvia Marchi).

All of these results outlined the coastal landscape in antiquity by 3D reconstructions [19, 17], and to understand its historical evolution in relation to San Cataldo level of importance, as a commercial port over time. In fact, the historical sources attest the resuming of the port activity between the medieval age and the modern one: an information confirmed by the archaeological data, which provides evidence of an increase of settlements in the area. Another research aspect included a study of historical maps, useful to define the coast aspect from a naturalistic point of view, indicate the presence of structures, that especially during the 19th century, led to the revaluation of San Cataldo as a tourist destination.



Figure 3 - San Cataldo (Lecce, Italy): Roman and 20th-century piers ruins aerial view (LabTAF, 2013).

Results

Data obtained from the surveys completed in the area of San Cataldo and its hinterland during the years, show how the transformation of the coastal landscape was influenced primarily by the decision to build a harbour since ancient times: a strategic choice for the city of Lecce, induced by commercial and military reasons. The element that most characterizes history of San Cataldo was the persistent will to realize a commercial place in a coastal site, but became less and less appropriate: in fact, cover-up and swamping events hindered the port development on several occasions. For this reason was considered unsafe for its purpose. After the Roman age, this goal was implemented in the medieval age and between the 19th and 20th centuries, with the construction of the new pier, the lighthouse and the tramway, connecting to Lecce. First bathing establishments were built in these last periods, which during the 20th century contributed to give to San Cataldo the tourist vocation that still distinguishes it.

The commercial vocation of San Cataldo ended a few years after the modern pier construction, immediately destroyed by the sea and reduced to ruins. Swamps draining works and reforestation gave way to the urbanization and soil cementation events, which heavily modified the coastal landscape, especially in recent decades.

Discussion

San Cataldo site represents, with its Roman pier, one of the most tangible examples of anthropic modification of the coast: a strategic infrastructure for the city of *Lupiae*, with economical and commercial implications [20] (fig. 3). The ancient remains are currently visible south of the lighthouse, near Piazza Adriano. Data collected during recent archaeological investigations made possible to determine the extent of the surviving structures: they occupy a linear surface of about 140 metres, half of which are submerged.

The construction technique of the pier consists in two walls of local limestone square blocks - usually placed with the long side exposed -, linked by transverse square block chains over different levels. Blocks have a length between 0.50 metres and 3.10 metres, an average width of 1 metre and an average height of 0.80 metres: the nucleus in Roman concrete is between the walls, made up of various and irregular sized stones mixed with lime mortar and brick fragments.

The pier ruins plan shows how the gap between the two walls, towards the submerged part, goes from 13 metres in the north end to 18 metres in the south one: this allows us to speculate about the quay width increase in the actual lost portion. Two prominent blocks with a 33 cm vertical circular hole diameter - plus traces of other two - are placed edgewise on the south wall: they are explained as mooring rings or as supports for lifting machines. Based on the overall dimensions, the pier was meant to dock small and medium-sized ships [15, 16, 17].

Among the ancient literary sources, Pausania mentions that port of San Cataldo is dating back to the Hadrian age; however is probable that a first equipped coastal landing was already present in the Augustan age, within the complex urbanization programme which characterized Roman city of *Lupiae* in that period. Traces of an ancient road axis near the pier can be ascribed to the connection between the city and the port in Roman age [28] (fig. 4).



Figure 4 - 3D reconstruction of San Cataldo Roman pier.

The anthropic presence on the coastal stretch is also associated to the remains of two republican age kilns, for the production of amphorae at Masseria Ramanno, surely linked to the activities of the nearby port of San Cataldo. Transport containers ceramic fragments and an anchor are attested near the Roman pier. At about 2 km south, in a place called San Giovanni, there are Late Republican and Imperial age wall structures, and a

series of pools for the production of salt. Furthermore, there are some building blocks alignments and a structure, having several rooms carved in the submerged rock in shallow water, that can suggest a fish farming complex. Near Cesine wetland, even more south, were identified similar structures referring to the Late Republican - early Imperial age, probably concerning the business activities linked to San Cataldo [7, 31, 4].

From this premises, it can be deduced how the coastal landscape in antiquity had a more advanced coastline than the current one. It was filled by various productions, gravitating around the port affairs and in natural environment that favoured their settlement.

The port of San Cataldo was probably functional to a series of small Byzantine settlements and two rock crypts, dating from the 8th and 10th centuries. Topographical surveys identified those in the area between Lecce and its coast [2, 3]: disappearance of productions activities on the coast, was a sign of the commercial traffic decreasing.

From the 12th to the 14th century, the area of San Cataldo became a small landing place, part of a desolate coast, with a partially impassable seabed caused by a shoal, called “Planca de Licze” in 13th-century sources. Furthermore, a large marshy area was extended close to the coast, surrounded by Mediterranean maquis and a vast wooded area called “foresta di Lecce (Lecce forest)”, extended from Otranto to Brindisi [22, 23].



Figure 5 - Detail of the “Carta Rilievi delle Coste dell’Adriatico dal fiume Tronto a Gagliano del Capo di S.ta Maria di Leuca” (1830-1835), indicating the tower/castle of San Cataldo and the coastal natural landscape (IGM Archive).

In the 14th century, Lecce became one of the major trading centres in Terra d'Otranto thanks to its important role, played within the Apulian trade fair circuit, the contextual reborn of a flourishing long-range maritime commercial traffic [27, 14]. San Cataldo returned to be one of the main port for the Adriatic Sea routes. It was fortified with the construction of a coastal tower in defence of the pier [34, 33], also used as a storage for merchants goods [23].

During the 16th century, the threat of invasions and looting by the Ottoman and more generally piracy in the Mediterranean sea, forced king Charles V to build a series of defensive structures along the coast of ViceKingdom of Naples: the old tower of San Cataldo became part of this great project and was restored in the middle of the century [10], with the pier as well [32]. The insecurity period induced the population to abandon many scattered farmhouses and to move towards the cities. At the same time there was a coastal natural landscape change, with a progressive stagnation of rainwater, caused by sandy dunes which stopped their path towards the sea: these large wetlands are outlined in the historical cartographies; they were extended for a width of about 5 km from the coast to the hinterland [11]. The tower of San Cataldo - also called castle - was later part of the 26 Kingdom of Naples marine strongholds, also shown in historical maps [5, 9] (fig. 5). From those maps it's possible to identify its location close right to the Roman pier [30]: currently the tower it doesn't exists anymore, probably destroyed by an English mine in the 19th century [4].

In the following centuries, San Cataldo's trade continued to flourish and numerous shops of Genoese, Florentine, Neapolitan, Greek and Venetian merchants settled in the city of Lecce. There were many goods in the centre of import-export business: timber, glass, iron, wine, cereals, sugar, coffee, fabrics but above all, Terra d'Otranto's lamp oil. Despite these aspects, port was considered less and less safe over time for various reasons, such as the old pier declining structural conditions, the tower scarce armaments and dangers due to the shallows. The commercial traffic of the port stopped in the first half of the 18th century: the pier was abandoned and the erosion of the sea contributed to the destruction of the most exposed structures, while those on the ground were buried by sand dunes [18].

San Cataldo renaissance occurred at the end of the 19th century, when the construction of a series of infrastructures aimed to get rid of the decline of trade in the territory, supporting the economical and touristic seaport development (fig. 6).



Figure 6 - Panoramic view of San Cataldo from the lighthouse, 19th century beginning (Cartelli 1981).

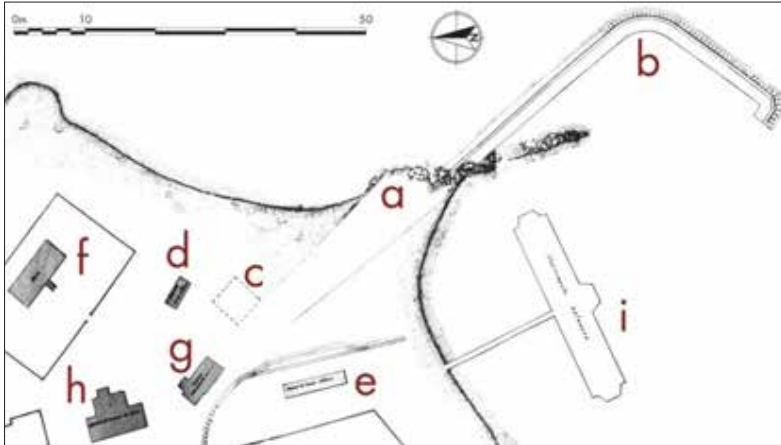

Figure 7 - Detail elaboration from “Planimetria del Progetto di massima per la sistemazione del Porto di San Cataldo presso Lecce” (1898 - Municipality of Lecce Archive) indicating: a) Roman pier ruins; b) Planimetric project of the new pier; c) Lost tower/castle site; d) Church of St. Cataldo; e) Tramway station; f) Lighthouse; g) Customs office; h) Hotel; i) Bathhouse on stilts.

It was built a tramway for a fast connection between Lecce and San Cataldo [11], a lighthouse [8] and a new pier - close to the ancient Roman one [29], that was partially demolished for construction material recycling -. As clear from the historical photos of that time, a tramway station, a small church dedicated to St. Cataldo, a customs office and a marine hospice completed the skyline of the coast, together with accommodation facilities such as an hotel [12], a restaurant and a bathhouse on stilts [6] (fig. 7). Coastal landscape of the period was very conditioned by a deforestation perpetrated over the centuries in favour of cultivated areas. However, in 1904 began the first reforestation of San Cataldo’s area, followed by an integral reclamation of the marshy areas, which ended during the first half of the 20th century [21].

In the early decades of the same century, the tramway and the church were removed, while the new pier was immediately affected by marine erosion, making it unusable. However, new bathing establishments were built and San Cataldo became a real tourist place, with new commercial activities and private homes linked to summer tourism. This caused deep changes in the naturalistic sector, due to excessive urbanization and coastal cementing events, which heavily modified the coastal landscape. In fact, San Cataldo’s coastline is the most affected one by coastal works done for recreational-tourist purposes. In addition with the creation of a series of coast modifications, useful for an artificial beach nourishment [13] (fig. 8).

Currently, the coast runs with a curvilinear trend for about 2 km up to Punta delle Cesine. The width of the beach is linked to the tides and can vary from a few tens of metres in the central portion - where the bathing establishments are, south-west of the lighthouse - to less than 5 m near the extremities. The ruins of the Roman and 20th-century piers retain

significant quantities of sand and algae on the sea currents exposed side, which leave amounts of variable materials on the shore. The strong soil consolidation cancelled all the rest of coastal dunes, which until a few decades ago were along the entire coast: an exception is represented by a modest dune belt, yet preserved in the north part of San Cataldo. The lithographic analysis of San Cataldo coast attested a sand deposit over a Plio-Pleistocene chalky rock, having a typical Salento's light sands alternation, with dark sands (coming from the volcanic deposits of Vulture Mount, transported by Ofanto River to Barletta on the Adriatic Sea and then south by the currents). The coast has shallow waters, with regular bathymetries that rapidly deepen below 100 m; it is affected by mostly perpendicular to the coast line winds and with the prevalence of a Sirocco current [1, 25].



Figure 8 - San Cataldo (Lecce, Italy): satellite view (SIT Puglia - 2008).

In conclusion, the geographical framework of San Cataldo coastal strip was significantly different from the current one at the beginning of the historical age. Studies have shown that in Greek-Roman Age the sea level was probably lower of about 3 m

compared to nowadays: its rise has therefore strongly set back the coast line [26, 31]. On the contrary, Roman pier area went through covering events, facilitated by the same ruins which at that point emphasized the coast line advancement. In the Middle Ages environment has changed with the formation of swampy areas and a progressive deforestation, solved only in the last century with drainage and reforestation works. Gave this fact, San Cataldo changed from a commercial port to a tourist destination (fig. 9).



Figure 9 - San Cataldo (Lecce, Italy): north aerial view (LabTAF, 2013).

Acknowledgments

Authors are grateful to Prof. Giuseppe Ceraudo and Prof. Carla Maria Amici (Department of Cultural Heritage, University of Salento - Lecce, Italy, coordinators of “*Portus Lupiae*” project) for their technical-scientific support and to Dr. Francesco Coppola for his assistance in translating this document.

References

- [1] Alvino L. (1974) - *Rilevamento costiero ed interpretazione idrodinamica dei sedimenti recenti lungo un tratto del litorale di S. Cataldo di Lecce*, Terra d’Otranto 18, 1-44.
- [2] Arthur P. (2010) - *Verso un modellamento del paesaggio rurale dopo il Mille nella Puglia meridionale*, Archeologia Medievale 37, 215-228. DOI:10.1400/183133
- [3] Arthur P., Leo Imperiale M., Muci G. (2018) - *Il Salento rurale nell’altomedioevo: territorio, insediamenti e cultura materiale*, Castrorao Barba A., *Dinamiche insediative nelle campagne dell’Italia tra Tarda Antichità e Alto Medioevo*, pp. 139-158, Archaeopress Publishing Ltd, Oxford.

- [4] Auriemma R. (2004) - *Salentum a salo. Porti, approdi, merci e scambi lungo la costa adriatica del Salento*, I-II, Congedo, Galatina.
- [5] Bruno F., Faglia V., Losso G., Manuele A. (1978) - *Censimento delle torri costiere nella Provincia di Terra d'Otranto*, Ist. Italiano dei Castelli, Roma.
- [6] Cartelli F. (1981) - *San Cataldo di Lecce 1833-1981. Storia e immagini di una stazione balneare*, Ed. Il villaggio, Novoli.
- [7] Ciardo M., Monte A., Montillo I., Stagira A.M. (2008) - *I porti e i fari di Terra d'Otranto*, Covino R., Monte A. (a cura di), *Il patrimonio industriale marittimo in Terra d'Otranto*, Viella, Roma, pp. 47-136.
- [8] Ceraudo G., Esposito F. (1997) - *Strutture sommerse a San Cataldo (Le)*, Atti del Convegno nazionale di archeologia subacquea, Anzio, Italy, 30 maggio - 1 giugno 1996, pp. 241-244.
- [9] Congedo R. (1960) - *Le vicende storiche nel mare di Lecce attraverso l'archeologia sottomarina*, La Zagaglia 2(5), 42-53.
- [10] Così G. (1989) - *Torri marittime di Terra d'Otranto*, Congedo, Galatina.
- [11] D'Armento, Mainardi (1992) - *Lecce – S. Cataldo. Una vecchia strada per il mare*, Del Grifo, Lecce.
- [12] De Giorgi C. (1913) - *La voce del mare: poche parole dette agli alunni della II classe dell'Istituto Tecnico di Lecce sulla spiaggia di S. Cataldo sull'Adriatico il 17 maggio 1913*, Augusto Pedone, Lecce.
- [13] Delle Rose M., Elia T. (2008) - *Aspetti geologici della conservazione delle spiagge del Salento*, Geologi e Territorio 1/2, 3-19.
- [14] Ferrari I. (2019) - *Vendendo in platea. Le fiere storiche di Gallipoli nel sistema economico-produttivo di Terra d'Otranto*, Esperidi, Soletto.
- [15] Ferrari I., Quarta A., Sammarco M., Carpentieri A., Di Tondo A. (2016) - *Portus Lupiae. 3D modeling and visual narrative for reconstructing a long maritime history*, Proceedings of the 8th International Congress on Archaeology, Computer Graphics, Cultural Heritage and Innovation 'ARQUEOLOGICA 2.0', Valencia, Spain, Sept. 5 – 7, 2016, pp. 452-455. DOI:10.4995/arqueologica8.2015.4156
- [16] Ferrari I., Quarta A. (2017) - *Portus Lupiae: new data for a reconstructive proposal*, Proceedings of 3rd IMEKO International Conference on Metrology for Archaeology and Cultural Heritage, Lecce, Italy, 23-25 October, 2017, pp. 583-588.
- [17] Ferrari I., Quarta A. (2019) - *The Roman pier of San Cataldo: from archaeological data to 3D reconstruction*, VAR - Virtual Archaeology Review, 10(20), 28-39. DOI:10.4995/var.2019.7957.
- [18] Foscarini A.E. (1984) - *San Cataldo «Porto et maritima» di Lecce*, ScorranoOffset, Lecce.
- [19] Gabellone F., Ferrari I., Giuri F., Chiffi M. (2017) - *3D technologies for a critical reading and philological presentation of ancient contexts*, Archeologia e Calcolatori 28(2), 591-595. DOI:10.19282/AC.28.2.2017.50
- [20] Gianfrotta P.A. (2005) - *Note di topografia marina e marittima*, Rivista di Topografia Antica XV, 7-36.
- [21] Mainardi M. (1988) - *L'acqua marcia. Le paludi del Salento tra Ottocento e Novecento*, Ghetonia, Calimera.
- [22] Mainardi M. (1989) - *I boschi del Salento. Spazi e storia*, Garofano Verde, Lecce.

- [23] Massaro C. (1993) - *Territorio, società e potere nei secoli XII-XV*, Vetere B., *Storia di Lecce. Dai Bizantini agli Aragonesi*, pp. 251-344, Laterza, Bari.
- [24] Merico A., Sammarco M. (2014) - *Archaeological Landscapes of Southern Apulia: Integration and Interpretation of Gis-Based Data in a Multi-Methodological Research*, LAC2014 Proceedings, 1-8. DOI:10.5463/lac.2014.45
- [25] Petracca L. (2011) - *L'espansione del circuito fieristico regionale nel Quattrocento. Fiere e mercati in Terra di Bari e Terra d'Otranto*, Massaro C., L. Petracca, *Territorio, culture e poteri nel Medioevo e oltre. Scritti in onore di Benedetto Vetere*, II, Congedo, Galatina, pp. 449-469.
- [26] Mastronuzzi G., Palmentola G., Sansò P. (1989) - *Osservazioni sulle caratteristiche fisiografiche dei litorali del Salento meridionale*, Atti del Convegno sulle conoscenze geologiche del territorio salentino. Lecce, Italy, 12 dicembre 1987, Quaderni Centro Studi di Geotecnologie d'Ingegneria 11, pp. 223-241.
- [27] Mastronuzzi G., Sansò P. (2002) - *L'evoluzione costiera dell'area di Torre Canne – T. S. Leonardo*, Atti del Workshop Variazioni tardo-quadernarie del livello del mare ed evoluzione della fascia costiera, Ostuni, Italy, 30-31 maggio 2002, pp. 53-59.
- [28] Sammarco M., Marchi S. (2008) - *“Il porto antico” di San Cataldo (Lecce): indagini tradizionali e nuove metodologie per uno studio topografico*, Archeologia Aerea III, 147-176.
- [29] Sammarco M., Marchi S. (2012) - *Tra terra e mare: ricerche lungo la costa di San Cataldo (Lecce)*, Journal of Ancient Topography XXII, 107-132.
- [30] Sammarco M., Parise M., Martimucci V., Pepe P. (2010) - *The contribution of GPR analysis to knowledge of the Cultural Heritage in Apulia (southern Italy)*, Proceedings of XIII International Conference on Ground Penetrating Radar, Lecce, Italy, 21-25 June 2010, pp. 70-76.
- [31] Valchera A. Zampolini Faustini S. (1997) - *Documenti per una carta archeologica della Puglia meridionale*, Metodologie di Catalogazione per i Beni Archeologici, BACT 1(2), 103-158.
- [32] Vantaggiato L. (2009) - *I mercanti nel Principato*, Somaini F., Vetere B., *I domini del Principe di Taranto in età orsiniana (1399- 1463)*, Congedo, Galatina, pp. 199-212.
- [33] Vantaggiato L., Vassallo M.R. (2019) - *Produzione, qualità, circolazione dell'olio salentino al tempo degli Orsini del Balzo (1399-1463)*, Itinerari di Ricerca Storica XXXIII(2), 45-76.
- [34] Vetere B. (2011) - *Otranto, San Cataldo e Brindisi. Gallipoli e Taranto. Centri costieri e porti del Salento*, Mediterranean Chronicle 1, 153-204.

ANOTHER SICILY, TUNA-FISHING STRUCTURES AND LANDSCAPE: A DIACHRONIC AND CONTEMPORARY PHOTOGRAPHIC JOURNEY ALONG THE SICILIAN WESTERN COAST

Mauro Fontana¹

¹Politecnico di Torino, phone +39 389 696 1530, e-mail: mauro.fontana@polito.it

Abstract – The conducted research includes a photographic and not photographic analysis about the Sicilian western coast landscapes starting with an historical study about *tonnare*, architectural heritage and physical expression of the tradition of the tuna fishing.

The first part of the research study the origins of tuna fishing in Sicily, also focusing on the architecture of *tonnare*. The second part, instead, includes a diachronic photographic reading through the photographic comparison between a reportage taken between 1986 and 1987 by Ernesto Scevoli and the photos taken by the writer in March 2018.

The results of the photographic research, which coincides with the last part of the paper, demonstrate that the Sicilian coastal landscape has undergone changes whose meaning is to be investigated in order to recover the coast qualities for the purposes of targeted actions of preservation and enhancement of architectural and landscape heritage.

Origins of tuna fishing

Thanks to its 1637 km of coastline and its strategic geographical position in the Mediterranean Sea, Sicily has a natural inclination towards activities related to the sea and fishing, so much so that it is the leading Italian region in terms of number of ports, fishing fleet and fished product. In particular, tuna fishing brings with itself stories that have their origins in a very distant time and that, over the centuries, have been greatly influencing the development of traditions and identity traits of people and societies. The tuna-fishing structures, called "*tonnare*", are the physical expression of that tradition: through these architectures along the coast, true instances of industrial archaeology findings, an identarian architectural and landscape heritage is conveyed.

Some graffiti painted on the walls of the Genovese Cave on the Island of Levanzo evidence that tuna-fishing was already practiced in prehistoric age. Several poets, philosophers, and historiographers of the classical world, such as Aristotle, Horace, Pliny, have written on tuna fishing. Its representation is very common in iconography, pottery, and coinage too. In some way, the Mediterranean civilisation is closely linked to the trade of tuna: already the Phoenicians fished and traded the tuna throughout the Mediterranean Sea starting from the 12th century b.C., along with purple, grains, oils, cheese and all other trade.

The *thunnus*, in fact, migrates from the ocean to the warmest waters of the Mediterranean Sea at the beginning of spring, making their fishing inside the labyrinths of nets that were built near the coasts favourable. In Sicily, thanks to its geographical position, there were numerous passages of tuna herds.

It is believed that the Muslims (Arabs, Berbers, Persians, Spanish) brought the almost industrial culture of tuna fishing, implemented its trade, and improved its technologies. Referring to the ideals of freedom, justice and tolerance of the teachings of Mohammed, the tuna trap was managed in a collective way, as if it were a co-ownership, with the absence of a single capital holder and with an equal distribution of income.

With the Normans and the introduction of the feudal system, economic and social history changed radically: the *tonnare*, in fact, were given in concession to barons, bishops, abbey, churches and convents and were subject to heavy taxes and services. With the organization that was established during the Middle Ages, the tuna-fishermen lost their autonomy and became simple "workers" who were paid a monetary compensation.

During the nineteenth century there will be an important growth in the trade and consumption of tuna, thanks to the effects of some technological innovations, such as the storage in oil and industrial processing.

During the first half of the 20th century, however, a slow process of divestment of *tonnare* began, and the reasons for which are to be found both in the difficulties of the archaic production process and in the competition from modern fishing systems practised by fishing vessels with the so-called "flying traps", which catch tuna on the high seas before they approach the coast.

The practice of tuna fishing, however, has left both material and immaterial legacies: on the one hand, architectures, equipment, industrial archaeology relics, on the other the important social reality that this practice represented, with its almost sacred nature that have left in the collective imagination stories of people who built their identity around the traditional tuna fishing.

Tonnare: nets and architectures

The term "*tonnara*" originally referred to the system of equipment and nets that were necessary for fishing, which were mounted at strategic points on the coast. In fact, the so-called "*tonnare of sea*" are nothing more than an underwater architectural system of nets anchored to the seabed, which form a series of interconnecting rooms. The last room was called the "death chamber" and allowed, through the lifting of the bottom net, the capture of the tuna that surfaced on the surface.

Today, the term "*tonnara*" is used to refer indiscriminately to both the nets and all the constructions on land that were used to store the equipment and process the tuna. Although the functions of the buildings were the same throughout the island, in order to deal with the architecture of the *tonnare* it is necessary to read the different complexes, which are developed in different ways and at different times. The development of the "*tonnare of land*" depended from several factors: the availability of construction materials, technical innovations, the morphology of the coast.

The system of the architectures of the *tonnare* is also intertwined with the system of territory control's towers. Buildings in fact, was equipped with a tower that had the dual function of sighting tunas and pirate attacks. For this reason, *tonnare*'s plants have a fortified conformation, like the traditional Sicilian countryside architectures: a planimetric scheme with a closed courtyard, equipped with walls to defend against possible incursions.

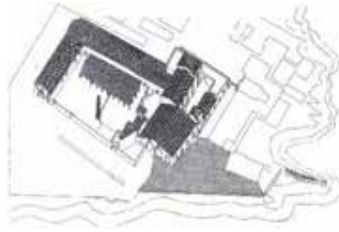

Figure 1 - Axonometry of a *tonnara*. From Ginex G. (1997) – *Luoghi della Memoria*, Jason, Reggio Calabria

The coastal building is called "*marfaraggio*", a term of Arabic origin which indicates the complex of buildings used as warehouses, storage, dormitories, etc. [25], and it is the pivotal place of the fishermen community: in fact, the *tonnare* often became the places where fishermen lived during the months when the nets were down (fig. 1).

During the months of fishing, the workers were a real community that lived inside the *tonnare*: for this reason, in fact, in addition to the places predisposed to the processing and preservation of tuna, there were spaces used as accommodation, a church or a chapel, kitchens and canteens, laundries.

The complexes, both in terms of typology and construction techniques, depended on local cultures and architectural style of the period: thus, there are *tonnare* with buildings with barrel vaults or flat roofs, with pointed or round arches, in neo-gothic or rationalist style. The materials used also are different in relation to the local materials and the economic factors. For all these reasons, each *marfaraggio* represents, as a settlement difficult to trace back to predetermined types, a historical and architectural heritage, but also cultural and anthropological, of considerable value and interest, whose reading is often complex [26]. The *tonnare*, moreover, are always located in places of extreme landscape value, characterized by precise physical conditions, in situations where the relationship between the sea and the anthropization of the coast has taken on particular characteristics and strong values [19].

From the *Royal Acts* to the diachronic photographic analysis

The starting point of the photographic research was the comparison of two temporally distant "sources": the "*Royal Commission Acts for the tuna fishing structures*", established by the Chamber of Deputies of the "*Kingdom of Italy*" from 1883 to 1887, and a photographic reportage by the Sicilian photographer Ernesto Scevoli, dating back to 1986/87 and published on the magazine *Domus* in 1992.

During the 19th century, tuna fishing was the topic of an important debate in the Chamber of Deputies of the "*Kingdom of Italy*". In fact several *tonnare*'s owners have requested a political debate to various ministries of the Italian Government since 1879, complaining that the price of Italian tuna in oil on the market was too low compared to products from others countries, such as Portugal, Spain and Tunisia.

A special Parliamentary Committee was thus set up in 1883 with the task of

“ascertaining the conditions of the Italian *tonnare* industry and indicating whether and what customs or other measures are needed to protect the industry and promote its development”. The Commission works began with an analysis about the activities of the five previous years (1879-1883) and a requesting to the maritime authorities of the ports all documents in their possession relating to both active and abandoned *tonnare*. The Commission's work was concluded with the drafting of the final report in 1887 and the acts' publication in 1889.

The Royal Commission Acts are an exact description of the activity of tuna fishing at the end of the 19th century. The maps are a precise mapping of active and abandoned *tonnare* throughout the Mediterranean Coasts (fig. 2). The maps show that the highest concentration of *tonnare* is distributed along the Sicilian coasts and that the active ones at the end of the 19th century were located in in the current provinces of Trapani and Palermo.



Figure 2 - General map from *Royal Commission Acts for the tuna fishing structures*.

The latter point should be taken into consideration since the photographic reportage of Scevoli has focused mainly on *tonnare* along the West coast of the island. For this reason, this conducted analysis concerned the buildings of Torretta Granitola, Favignana, Nubia, San Giuliano, San Cusumano, Bonagia, San Vito Lo Capo, Scopello, Cinesi, Vergine Maria, Arenella e San Nicola l’Arena.



Figure 3 - Ernesto Scevoli's reportage published on Domus in 1992. General map from *Royal Commission Acts for the tuna fishing structures*.

The conducted research includes a diachronic photographic reading, using the photographic method of before-and-after for the comparison between the photographs taken between 1986 and 1987 by Ernesto Scevoli and the photos taken by the writer in March 2018, investigating around photography's relationship with time and imagination too (fig. 4-5).

If Ernesto Scevoli's reportage was born with the aim of being published on the magazine *Domus*, giving the subject national and international visibility, the diachronic analysis clearly demonstrates how little has been produced over the last 30 years in terms of preservation and enhancement. In 2018's images, in fact, are no longer evident signs of fishing (anchors, nets, etc.); instead, what emerges are different spaces, which have not always found a proper function within the landscape in which they fit.

In fact, photography always chooses what to show, sometimes forcing some views and preferring them over other ones. If in 1987 it was right to focus only on the divestiture in progress in a "romantic" way, today we must give photography a different role: it must become a language to discover, know, represent and understand the complexity of reality without constraints and aesthetic-formal obsessions, without hiding or removing parts.



Figure 4 - Tonnara of Bonagia, diachronic comparison. On the left: 1987, © Ernesto Scevoli/Studio Camera. On the right: 2018, © Mauro Fontana.



Figure 5 - Tonnara of San Vito Lo Capo, diachronic comparison. On the left: 1987, © Ernesto Scevoli/Studio Camera. On the right: 2018, © Mauro Fontana.

Another Sicily: the contemporary journey along the coast

As expression of cultural and historical identities, the landscape is an inalienable right of people and communities. However, “other landscapes”, almost invisible, often appear right in front of our eyes, rendering us unable to narrate them. Those are territories that need to be redesigned, landscapes that need to be repossessed, reinvented, or rebuilt.

The Sicilian coastal landscape is made up of changing fragments, it changes and damage by physical and social phenomena, due to both individual behaviour and inefficient planning and maintenance. The last century building development, in fact, has gone through a phase of development mainly quantitative, occupying sensitive areas and territories with low-quality architectures and spaces. And these architectures are the one that affects the appearance of the most remote territories and landscapes.

Italo Calvino said that “[...] to see a city is not enough to keep eyes open. First of all, we must discard everything that prevents us from seeing it, all the received ideas, the pre-constituted images that continue to fill our visual field and our ability to understand; then it is necessary to know how to simplify, reduce to the essential of the viewer, and connect the scattered fragments in an analytical and unitary drawing [...]”¹.

For this reason, it was necessary to interpret a broader context in order to identify those landscapes that tell a familiar and invisible world along the coast, close to everyone and removed from the common eye. Talking about landscape, however, does not mean enlarging the field of observation to embrace wider portions of territory², but it just must be a different way of looking at the same things. It is also necessary to assume the awareness that contemporary landscape is a “hybrid landscape”, heterogeneous, generated by contrast and juxtaposition of different elements.



Figure 6 - Bonagia, Trapani. 2018, © Mauro Fontana.

¹ Calvino I. (1995) - *Una pietra sopra*, Mondadori, Milano.

² Zardini M. (1996) - *Per il ritorno del pittoresco*, “Paesaggi Ibridi. Un viaggio nella città contemporanea”, p. 22, Skira Editore, Milano.

"Another Sicily" was born from the need for a new interpretative and critical reading of the landscapes around the *tonnare* along the Sicilian western coast. The photos of *Another Sicily* don't tell the story of tonnare and their traditions, but the present status of the coast today, its accesses to the sea, its infrastructure, the casual use of many fringes, the low-quality architecture that invades the territories, the distance from essential services, and the social-spatial fragility, trying to establish a relationship between heritage and landscape.



Figure 7 - Vergine Maria, Palermo. 2018, © Mauro Fontana.



Figure 8 - Trapani. 2018, © Mauro Fontana.

Photography then becomes an instrument to discover, know, represent and understand reality, in a continuous dialogue between landscape and traces of man, between natural and built environment, an instrument to stimulate people to look at places in a

different way, making visible the imbalance that is sometimes generated between the cultural heritage and the context landscape. The aim is to offer the possibility to analyse aspects and values that allow to know the places that can be or will be object of transformation and design processes.

In this "contemporary grand tour", the *tonnare* only were a small part of the journey, scattered points throughout the territory and the landscape. And the new photographic and topographic project tells about the territories close to them, territories of passage, the areas in the middle between heritage and nature, between the landscape and the built environment.



Figure 9 - Torretta Granitola, Trapani. 2018, © Mauro Fontana.



Figure 10 - Favignana, Trapani. 2018, © Mauro Fontana.

Acknowledgments

This work is the result of a long period of research for the Master of science in Architecture for Heritage preservation and enhancement's dissertation, discussed at the Politecnico di Torino in July 2018, for which I thank the supervisors Carla Bartolozzi and Daniele Regis for believing in it and in me.

A special thanks goes to Ernesto Scevoli, a wonderful photographer, and a special friend: his photos are an important testimony of a part of history in danger of being forgotten.

References

- [1] AA.VV (1880) - *L'industria delle tonnare in Italia*, 1^a ed., Stabilimento Pellas, Genova
- [2] AA.VV. (1889) - *Atti della Commissione reale per le Tonnare*, Ministero di Agricoltura, industria e commercio, Divisione industrie, commerci e credito, 1^a ed., Tipografia Eredi Botta, Roma
- [3] AA.VV. (1980) - *La cultura materiali in Sicilia*, 1^a ed., Università di Palermo, Facoltà di Lettere e Filosofia, Palermo
- [4] AA.VV (1989) - *Matrici e permanenze di culture egemoni nell'architettura del bacino del Mediterraneo*, 1^a ed., Flaccovio, Palermo
- [5] Basile G. (2012) - *Tonnare indietro nel tempo*, 1^a ed., Flaccovio, Palermo
- [6] Carcasio M. (1996) - *Archeologia industriale e storia del lavoro in Sicilia*, Ministero dei Beni Culturali e Ambientali, Regione Siciliana, Assessorato ai Beni Culturali e Ambientali, Palermo
- [7] Consolo V. (1987) - *La pesca del tonno in Sicilia*, 1^a ed., Sellerio, Palermo
- [8] Danzuso G.L., Zinna E. (1987) - *La mattanza: il ritorno di Ulisse*, 1^a ed., Maimone, Catania
- [9] De Cristofaro S. (1970) - *Le tonnare italiane: la evoluzione tecnologica ed ubicazionale, le prospettive*, 1^a ed., Industria grafica nazionale Consentino, Palermo
- [10] Di Paola Avolio F. (1805) - *Delle leggi siciliane intorno alla pesca. Opera dell'avvocato Di Paola Avolio*, 1^a ed., Reale Stamperia, Palermo
- [11] Drago D. (1999) - *Tonnare*, 1^a ed., Società editrice L'Epos, Palermo
- [12] Epifanio L. (1939) - *L'architettura rustica in Sicilia*, 1^a ed., Palumbo, Palermo
- [13] Fresina A., Maurici F., Militello F. (2008) - *Le torri nei paesaggi costieri siciliani: secoli XIII-XIX*, Regione Siciliana, Assessorato dei beni culturali, ambientali e della pubblica istruzione, Dipartimento dei beni culturali, ambientali e dell'educazione permanente, 1^a ed., Palermo
- [14] Ginex G. (1992) - *Domus itinerario n. 76: le tonnare in Sicilia*, Domus 735
- [15] Ginex G. (1997) - *Luoghi della Memoria*, 1^a ed., Jason, Reggio Calabria
- [16] Giovanni M. (a cura di) (1986) - *Villabianca, Le tonnare della Sicilia*, ristampa, Edizioni Giada, Palermo
- [17] La Mantia V. (1901) - *Le tonnare in Sicilia*, 1^a ed., Stabilimento Tipografico Giannitrapani, Palermo
- [18] Lacagnina D. (2010) - *Attraverso il paesaggio: l'immagine della Sicilia fra pittura, fotografia e letteratura (1861-1921)*, 1^a ed., Kalos, Palermo

- [19] Lo Curzio M. (1991) - *L'architettura delle tonnare*, 1^a ed., EDAS, Messina
- [20] Manzi S., Farina D. (1986) - *Tonnare in Sicilia: indagine storico-geografica*, 1^a ed., Università di Palermo, Facoltà di Magistero, Istituto di Scienze Geografiche, Palermo
- [21] Mazzarella S., Zanca R. (1985) - *Il libro delle torri. Le torri costiere di Sicilia nei secoli XVI-XX*, 1^a ed., Sellerio, Palermo
- [22] Pitre G. (1980) - *La famiglia, la casa, la vita del popolo siciliano*, 1^a ed., Arnaldo Forni, Bologna
- [23] Salerno F. (2009) - *Uomini, tonni e tonnare di Sicilia*, 1^a ed., Marrone, Siracusa
- [24] Sarà R. (1983) - *Tonni e tonnare. Una civiltà, una cultura*, 1^a ed., Libera Università di Trapani, Trapani
- [25] Sarà R. (1998) - *Dal mito all'aliscafo. Storia di tonni e di tonnare. Migrazioni e biologia, leggende, tradizioni e socialità*, 1^a ed., Arti grafiche siciliane, Palermo
- [26] Sposito C. (2007) - *Le tonnare: storia e architettura*, 1^a ed., Flaccovio, Palermo
- [27] Sposito C. (2009) - *Architettura del paesaggio tra mare e terra*, Territori Contesi: campi del sapere, identità locali, istituzioni progettualità paesaggistica, Istituto di Geografia, Università di Urbino "Carlo Bo", Pollenza
- [28] Vittorio U. (1989) - *Dimensioni teoriche dell'architettura del paesaggio. L'architettura rurale nelle trasformazioni del territorio in Italia*, 1^a ed., Laterza, Bari

IL DESIGN SISTEMICO PER LA VALORIZZAZIONE DEL PATRIMONIO FARISTICO ITALIANO

Gianluca Grigatti¹, Pier Paolo Peruccio²

¹ Politecnico di Torino – Dipartimento di Architettura e Design (DAD),
via Pier Andrea Mattioli 39, 10135 Turin (Italy), e-mail: gianluca.grigatti@polito.it

² Politecnico di Torino – Dipartimento di Architettura e Design (DAD),
via Pier Andrea Mattioli 39, 10135 Turin (Italy), e-mail: pierpaolo.peruccio@polito.it

Abstract – This paper focuses on the Mediterranean coastal monitoring actors (i.e. maritime signaling instruments) such as lighthouses, lights, traffic lights. A twofold motivation behind this choice: on the one hand the 110th anniversary - that will be celebrated in 2021 - of the transfer of the management of the lighting service of the coasts from the Italian Ministry of Public Works to the Navy. On the other hand, the willing to illustrate and experiment how the Systemic Design methodology can represent a strategic element for the enhancement of a coastal heritage such as the one represented by lighthouses.

These monuments represent a unique system whose history led them to dialogue, to establish a relationship with the territory in which they are located. It seemed natural to think about the metaphor of the rhetorical figures proper to the story, or the plot and the warp which design a network in the territory: the Warp, the Weft and the Web.

The enhancement of this heritage, therefore, corresponds to the evolution and maturation of a history of ideas with reference to those that are part of the design policy strategies for the Italian Cultural Heritage.

In particular, by focusing attention on the concepts of conservation, protection, use and enhancement, we want to underline that they are not only intended as mere regulatory factors to be applied. They must be assumed by the designer, the conservator and the legislator himself as components of a wider systemic design issue.

Introduzione

“Ogni evento umano ha riflessi che toccano la lingua, perché attraverso la lingua gli uomini prendono coscienza dei fatti, li soppesano, li giudicano, ne traggono le conseguenze. Le tracce dei fatti restano appiccate alle parole”. Con queste parole il 9 marzo 2020 Claudio Marazzini, Storico della Lingua Italiana e Presidente dell'Accademia della Crusca, attraverso il sito della prestigiosa Istituzione, cercava di declinare in termini linguistici il sentimento che pervadeva la maggior parte della popolazione italiana, e non solo, di fronte alla difficoltà ed, al contempo, alla necessità di affrontare e descrivere con le parole più adatte il sentimento di sconcerto che la diffusione del Sars-CoV-2 continuava (e, purtroppo, continua ancora) a suscitare¹.

¹Marazzini C. (2020) - *In margine a un'epidemia: risvolti linguistici di un virus*, <https://accademiadellacrusca.it/it/contenuti/in-margine-a-unepidemia-risvolti-linguistici-di-un-virus/7895>

Assumendo quanto indicato da Marazzini come metafora, e mutandola al contesto in esame, ovvero il tema proposto dall'VIII Simposio Internazionale incentrato su “Il Monitoraggio costiero Mediterraneo: problematiche e tecniche di misura”, gli autori hanno deciso di focalizzare la propria attenzione sul significato del sostantivo “monitoraggio”.

Identificata quale “attività di osservazione a scopo di controllo di una grandezza variabile eseguita mediante l'impiego di appositi strumenti”, tale significato ha condotto gli scriventi ad mettere in relazione la tematica lanciata dal Simposio con l'attività di ricerca da essi iniziata e coordinata fin dal 2019 - ed attualmente ancora in corso - avente come soggetto la valorizzazione in termini sistemici di un patrimonio inedito e, fino ad ora, visto esclusivamente in maniera particolare, quali si configurano gli strumenti del segnalamento marittimo: fari, fanali, mede e boe².

Nello specifico lo spostamento dell'interesse di ricerca dall'azione di monitoraggio agli attori del monitoraggio, risulta determinata da una triplice motivazione: innanzitutto la celebrazione di un anniversario, il 2021, infatti, coinciderà con la ricorrenza del 110° anniversario del passaggio della gestione del Servizio d'illuminazione e del segnalamento delle coste dal Ministero dei Lavori Pubblici alla Marina Militare (per effetto del Regio Decreto n° 294 del 9 Marzo 1911); secondariamente dall'accezione stessa insita nel concetto stesso di contesto il quale, con riferimento alla disciplina sistemica, esplicita un significato più specifico rispetto a quello comune, sottendendo: «Una relazione complessa, aggrovigliata e in continuo divenire tra il tutto e le parti, tra soggetti e gruppi/istituzioni/sistemi di interazioni. [...] L'interconnessione, quindi, è insita nel contesto, analogamente a ciò che avviene in un tessuto dove trama e ordito nascono insieme, intrecciati, connessi»³; infine, ma naturale conseguenza a quanto illustrato precedentemente ed insito nella definizione di contesto, la volontà d'illustrare e sperimentare come la metodologia del Design Sistemico rappresenti un vero e proprio elemento strategico per la valorizzazione di un patrimonio costiero quale si configura quello faristico.

Pur rappresentando un'attività di ricerca ancora in corso, e quindi con risultati estremamente parziali, ciò non esime gli autori dal provare a trarre prime considerazioni riguardanti la metodologia di ricerca impiegata in virtù della quale indentificare l'insieme dei fari come un sistema unico la cui storia che alla loro luce si è determinata li porta implicitamente a dialogare e ad intessere un intreccio di avventure con il territorio in cui si trovano. In tal senso cui è sembrato più che naturale usare e pensare alla metafora delle figure retoriche proprie del racconto, ovvero la fabula/trama (*Weft*) e l'intreccio/ordito (*Warp*), come sistema/rete (*Web*) per raccontare in modo inedito la storia di un territorio.

La metodologia: il Design Sistemico

Per comprendere i principi che governano il Design Sistemico e quindi le azioni compiute dai progettisti è opportuno analizzare l'etimologia della parola greca *sinastae*. Questo termine significa “mettere insieme le cose in un ampio insieme”, questo insieme è caratterizzato dal contesto, il territorio.

² Cacciavellani B., Mazzi R. (2011) - *Sentieri di luce. Cent'anni di fari con la Marina Militare*, Marina Militare, Servizio Fari.

³ Formenti L. (2018) - *L'arte di contestualizzare nella consulenza ai sistemi umani*, in *Riflessioni Sistemiche* - N. 18, Giugno, p. 32. http://www.aiems.eu/files/rs18_formenti.pdf

Una macchina è un sistema di componenti, ognuno con le sue specificità e le sue peculiarità, che lavorano insieme per garantire il movimento. Lo stesso vale per un territorio, ma con un'unica differenza: nel territorio il progettista non sceglie le peculiarità in base alle funzionalità che vuole ottenere ma esalta quelle che ha a disposizione.

Un sistema è costituito da elementi, coerentemente connessi a uno scopo, per far funzionare qualcosa. Un sistema deve essere costituito da tre tipologie di voci principali: elementi, interconnessioni e scopo.

Su tali basi metodologiche l'approccio sistemico mira ad avere un peso reale, conformando progetti caratterizzanti il territorio in cui interviene. Al contrario dell'approccio lineare, l'attenzione è focalizzata sull'economia locale. L'errore dell'industrialismo è infatti quello di pretendere che gli stessi principi lineari e seriali siano applicabili ovunque. Un approccio di questo tipo mira a un'efficienza effettiva esclusivamente per gli imprenditori a capo delle grandi industrie multinazionali⁴.

Il limite di questo *modus operandi* che ha caratterizzato l'ultimo secolo è individuabile anche nelle previsioni sviluppate da J. Randers nel rapporto stilato per il Club di Roma "2052". Nel saggio Randers evidenzia come i quarant'anni successivi alla scrittura dello stesso (2012-2052) saranno influenzati dal modo in cui verranno affrontati cinque problemi di importanza basilare: il capitalismo, la crescita economica, la democrazia, l'equità intergenerazionale e il nostro impatto sul clima globale. Questi problemi sono, in maniera diversa, tutti collegati a un approccio al progetto per il territorio di questo tipo. Per questo è necessario adottare il punto di vista del territorio nella definizione di efficienza.

Il concetto di efficienza adottato dalla metodologia sistemica mira invece a distribuire questa ricchezza tra tutti i soggetti appartenenti al sistema locale, generando così ricchezza all'interno della comunità. La parola ricchezza non si riferisce solo al profitto economico ma amplia il concetto agli aspetti ambientali e sociali, contribuendo così al raggiungimento di una condizione di benessere. Le economie locali possono sfruttare al massimo le potenzialità di un approccio sistemico facendo della propria diversità una risorsa, al contrario dell'industria che la considera come un ostacolo da superare tramite processi di omologazione che favoriscono indirettamente un impoverimento culturale, ecologico e produttivo⁵.

Prodotti, relazioni, risorse, stakeholder, interazioni, interdipendenze, flussi, input/output, società, ambiente, economia locale, benessere, resilienza, valore: sono questi gli elementi con cui il Designer Sistemico guarda al progetto e al contesto di applicazione dello stesso, il territorio. Questo approccio permette di ri-configurare le dinamiche che caratterizzano un territorio secondo le sue reali specificità, giungendo a nuove ipotesi di senso. Esso, pertanto, si caratterizza come uno strumento di riprogettazione e di connessione del singolo elemento al sistema di cui fa parte, del micro al macro, dell'economia all'ambiente e alla società. L'analisi del sistema su cui si interviene non mira allo sviluppo di soluzioni specifiche cui eliminare la perdita di risorse in determinati punti del sistema. L'obiettivo è attuare un intervento diffuso.

In particolare, il designer sistemico mira a valorizzare al massimo ogni output che

⁴ Bistagnino L. (2009) - *Design sistemico. Progettare la sostenibilità produttiva e ambientale*, Slow Food Editore. Bra.

⁵ Bistagnino L. (2009) - *Design sistemico. Progettare la sostenibilità produttiva e ambientale*, Slow Food Editore. Bra.

viene disperso fuori dal sistema affinché possa divenire un input per altre attività nuove o esistenti all'interno del sistema stesso. Nel caso dei rifiuti, ad esempio, il focus non riguarda la limitazione dello spreco a fine corsa, quando si ha a che fare principalmente con esso, ma si cerca di prevenirne la generazione, connettendo tra loro i diversi attori non solo per quello che fanno ma per la funzione che rivestono all'interno del sistema⁶.

Le definizioni e le descrizioni raccolte fin qui a proposito dell'approccio al progetto del designer sistemico aiutano a comprendere la grande flessibilità di questi progettisti. Dall'analisi dei paper dei progetti sviluppati da queste figure professionali è inoltre evidente la collaborazione con svariate tipologie di aree disciplinari. Altro aspetto peculiare di questi progetti è il ruolo di coordinamento assunto da questi progettisti tra attori diversi. Infatti, come sottolineato da Celaschi: «*designer born as a sole and independent author, close to the material creation, has gradually abandoned his despotic and absolute aura to assume the identity of who proceeds and looks for collaborations, as interacting part with other figures*»⁷.

Nel grande contenitore del Design, il Design sistemico si insedia in quel campo di analisi che comprende gli aspetti umanistici (*Humanities*) a quelli di gestione (*Economy e Management*) puntando alla creazione di valore dall'integrazione e la consapevolezza dell'ampio bagaglio professionale a disposizione.

Si tratta di una metodologia progettuale che guarda all'intero sistema-prodotto collocato in un preciso contesto sociale, politico, economico e culturale, della progettazione strategica di uno scenario in grado di andare oltre l'innovazione di prodotto fine a se stessa sviluppando temi ad ampio raggio su cui devono necessariamente convergere altri saperi⁸.

Uno di questi temi riguarda la valorizzazione degli attori del monitoraggio costiero con particolare riferimento a quei monumenti/storici ma ancora operativi, quali si presentano i Fari.

Per un Paese come l'Italia a vocazione marittima e che basa la propria economia sui traffici commerciali, la possibilità di disporre di una rete di segnalamenti efficace e moderna rappresenta un'importante valenza strategica.

Nonostante gli attuali sistemi di navigazione e di monitoraggio delle coste abbiano relegato i fari in un campo che ha a che fare più con il loro valore storico sul territorio rispetto alla loro utilità operativa, il costante sviluppo ed espansione delle aree portuali li rende un indispensabile ausilio e garanzia di sicurezza per la navigazione.

In conseguenza della progressiva riduzione del personale farista e delle esigenze alloggiative, di concerto con l'Agenzia del Demanio e Difesa Servizi S.p.A., si è cominciato a perseguire un programma finalizzato al recupero e alla riqualificazione degli immobili non più utili al Servizio Fari, valorizzarli si evitarne il deterioramento.

In tal senso si è sviluppato il progetto "Valore Paese - fari" in base al quale una serie di strutture costiere sono state rese disponibili per una possibile valorizzazione secondo il modello di *lighthouse accomodation*.

⁶ Fassio F., & Tecco N. (2019) - *Circular Economy for Food: A Systemic Interpretation of 40 Case Histories in the Food System in Their Relationships with SDGs. Systems.* <https://doi.org/10.3390/systems7030043>

⁷ Celaschi, F. (2017) - *Non industrial design*, Luca Sossella, Milano

⁸ Peruccio P. P., Vrenna M., Menzardi P., & Savina A. (2018) - *From "The limits to growth" to systemic design: Envisioning a sustainable future.* Cumulus Conference Proceedings Wuxi 2018 - Diffused Transition and Design Opportunities.

Naturalmente rimangono escluse dalla concessione le torri faro (e relative lanterne), inalienabili poiché strumentali alla funzione istituzionale di ausilio alla sicurezza della navigazione marittima svolta dal Servizio fari.

Ed è per la valorizzazione di un tale patrimonio culturale operativo che si sta sperimentando la metodologia del design sistemico configurando azioni progettuali innovative ed in grado di generare nuove ipotesi di senso.

In particolare, esse si pongono l'obiettivo di perseguire la ricerca di un equilibrio tra azioni di conservazione ed azione di fruizione nel contesto delle quali viene a costituirsi la cifra etica dell'azione di valorizzazione stessa.

Nel solco dell'indirizzo di ricerca tracciato viene quindi a sostanzarsi un campo ancora fortemente inesplorato da parte del design ma in cui esso può, e sempre più potrà in futuro, esplicitare la propria azione di elemento catalizzatore⁹.

Conclusioni

«Piuttosto che interrogarsi su cosa sia, il design dovrebbe avviare un lavoro di ricostruzione dei modi e delle norme con cui, nelle varie fasi storiche, il concetto di design si è rappresentato, tenendo conto di come esso implichi anche il definirsi della figura del designer e del suo ruolo»¹⁰.

Con queste parole nel 1991, terminava l'*open lecture* presentata da Vanni Pasca al 1° Convegno Internazionale di studi storici sul design incentrato sul tema "Storia e Storiografia".

Sebbene siano trascorsi quasi 25 anni da quella data, e nonostante la riflessione degli storici, dei designer e degli architetti invitati in quel convegno fosse indirizzata alla natura ed alla situazione degli studi storici in Italia, quanto affermato da Pasca può contestualizzarsi anche ad un campo come quello in oggetto nel quale il design, parafrasando quanto affermato da Salvatore Settis nel corso del suo intervento al convegno nazionale del FAI - Fondo Ambiente Italiano - del 2006, si pone sulla stessa lunghezza d'onda di tutela, gestione e valorizzazione in quanto «momenti intimamente connessi di un processo unico, [e] che hanno senso solo se ispirati da un'istanza unificante: la ricerca conoscitiva sui beni da tutelare e gestire»¹¹.

Da ciò ne consegue che la valorizzazione di un tale patrimonio corrisponde all'evoluzione di una storia delle idee che, se pur ascrivendosi a quelle facenti capo alle strategie di design policies per il Patrimonio Culturale Italiano, focalizzando l'attenzione sui concetti di conservazione, tutela, fruizione, essi devono essere intesi non tanto quali fattispecie normative da applicare, bensì debbano venir assunte dal progettista, dal conservatore e dallo stesso legislatore (in virtù della loro presenza nel Decreto Legislativo del 22 gennaio 2004, n.42 e sue successive modificazioni) quali componenti di una più ampia questione progettuale di natura sistemica.

⁹ Grigatti G. (2014) - *Valorizzazione, fundraising, design: un'innovazione sostenibile per il patrimonio culturale italiano*, in *A Matter of Design: Making Society through Science and Technology*, Coletta C., Colombo S., Magaudo P., Mattozzi A., Parolin L.L., Rampino L., (a cura di), pp. 99 – 109

¹⁰ Pasca V. (1991) - *Design: storia e storiografia*, in *Design: storia e storiografia. Atti del I Convegno Internazionale di Studi Storici sul Design*, Pasca V. e Trabucco F., (a cura di) Milano, p. 20.

¹¹ Settis S. (2005) - *Battaglie senza eroi. I beni culturali tra istituzioni e profitto*, Electa, Milano.

References

- [1] Bistagnino L. (2009) - *Design sistemico. Progettare la sostenibilità produttiva e ambientale*, Slow Food Editore. Bra.
- [2] Cacciavellani B., Mazzi R. (2011) - *Sentieri di luce. Cent'anni di fari con la Marina Militare*, Marina Militare, Servizio Fari.
- [3] Celaschi, F. (2017) - *Non industrial design*, Luca Sossella, Milano
- [4] Fassio F., & Tecco N. (2019) - *Circular Economy for Food: A Systemic Interpretation of 40 Case Histories in the Food System in Their Relationships with SDGs. Systems*. <https://doi.org/10.3390/systems7030043>
- [5] Formenti L. (2018) - *L'arte di contestualizzare nella consulenza ai sistemi umani*, in *Riflessioni Sistemiche* - N. 18, Giugno, p. 32. http://www.aiems.eu/files/rs18_-_formenti.pdf
- [6] Grigatti G. (2014) - *Valorizzazione, fundraising, design: un'innovazione sostenibile per il patrimonio culturale italiano*, in *A Matter of Design: Making Society through Science and Technology*, Coletta C., Colombo S., Magaudda P., Mattozzi A., Parolin L.L., Rampino L., (a cura di), pp. 99 – 109
- [7] Marazzini C. (2020) - *In margine a un'epidemia: risvolti linguistici di un virus*, <https://accademiadellacrusca.it/it/contenuti/in-margine-a-unepidemia-risvolti-linguistici-di-un-virus/7895>
- [8] Pasca V. (1991) - *Design: storia e storiografia*, in *Design: storia e storiografia. Atti del I Convegno Internazionale di Studi Storici sul Design*, Pasca V. e Trabucco F., (a cura di) Milano, p. 20.
- [9] Peruccio P. P., Vrenna M., Menzardi P., & Savina A. (2018) - *From “The limits to growth” to systemic design: Envisioning a sustainable future*. Cumulus Conference Proceedings Wuxi 2018 - Diffused Transition and Design Opportunities.
- [10] Settis S. (2005) - *Battaglie senza eroi. I beni culturali tra istituzioni e profitto*, Electa, Milano.

COASTAL HERITAGE AND TERRITORIAL SIGNS

Antonietta Ivona

Università degli Studi di Bari Aldo Moro, Largo Abbazia S. Scolastica n. 53 - 70124 Bari

Phone +39 080 5049062, e-mail: antonietta.ivona@uniba.it

Abstract – Geographical space must be understood as a progressive and conscious construction - both from an individual and a collective point of view - in which the geographical elements and the relationships between the elements themselves are placed. From the post-World War II period and for the following twenty years, the coastal area has maintained an albeit minimal break with the man-made spaces; since the seventies of the last century, rapid industrial development has increasingly occupied the coasts.

Over time, the overlapping of the various activities, more attentive to economic benefits than ecological values, has designed a complex system of occupation of this delicate space according to whether the purpose was the occupation of the coast or the coastal sea. The ties, interests, and conflicts that arise in the maritime-coastal region (and which project themselves into wider spaces than those actually covered by its constituent elements) make it impossible to define a pre-established amplitude.

Historically, then, coastal regions have played the role of cultural transmission areas, where people, goods and goods and ideas from abroad are mixed with local and traditional ones. Today, cultural heritage plays a central role in the narratives of coastal regions and in their reorganization as places and / or containers of historical, cultural, social and economic principals.

Among the most evident coastal territorial signs are the lighthouses. The analysis intends to reflect on the path of transformation of lighthouses in Italy and of the other coastal structures being divested by the State, with the awareness that similarly to other processes, even that of the conservation and reuse of cultural resources, such as lighthouses, cannot take place anywhere alike.

Each territory is the result of the historical-cultural values that have shaped it over time and, therefore, they will have to be taken into account in the processes of re-inclusion of those structures in the economic and social life of the host community.

Coastal space as heritage

Coastal areas are currently areas of significant interest in the contemporary urban condition both for the variety of environmental, historical and cultural landscapes they include and also for their transitional character and interface between the hinterland, the coast and the sea. "These territories are often associated with dynamics related to leisure and tourism activities; they show out-of-the-ordinary spaces, themed environments in which landscapes are produced, marketed and consumed but at the same time they show a propensity to assume a plurality of meanings and become attractive areas of social interaction and collective interest, as they are characterized by relevant environmental and cultural qualities. Often, they are external to the dynamics and critical issues of the compact city." [1] (p. 150). Under the gaze

of the tourist, the coasts are considered places where human life was simple and picturesque, transforming them into heritage and generating new forms of income. [2]

Heritage can be defined as the set of tangible and intangible assets in which a group, company or nation takes on the heritage of its past, to be preserved in the present also for the benefit of future generations. "Heritage is not given and definable a priori, nor unique in terms of value hierarchies: what is considered heritage by one generation may not be considered as heritage by another generation, and then be re-evaluated by the next one. In fact, the legacy we are talking about only makes sense if those who inherit reinterpret, inscribe that legacy in their present." [3] (p. XX). It is also important to question the sense of collective heritage or that set of values, symbols and territorial signs in which a community recognizes itself and through which it transmits its identity.

Geographical space must be interpreted, from both an individual and a collective point of view, as a progressive and conscious construction in which the geographical elements and the relationships between the elements themselves are placed. If since the second post-war period and for the following twenty years, the coastal area has maintained an albeit minimal break with the man-made spaces, since the seventies of the last century, rapid industrial development has increasingly occupied the coasts.

To understand that new geoeconomic organization, it is necessary to refer to the conceptual contrast between growth and development that in those years appeared in the scientific debate "The organization after the Second World War was dominated by the idea of growth: to the expansion of economies it corresponded along the coasts of the western world, an expansion of structures; the phenomenon of gigantism ensued." [4], (p. 369). For a long time what was simple growth was considered development with a completely positive meaning. "Occupying the coast progressively and enslaving the coastal sea for a long time has been considered an inevitable effect of development while it was simply a matter of growth and events generating considerable environmental effects. The negative feedback chains, which were triggered in an increasing number of coastal fronts, first went unnoticed then were considered an inevitable cost to pay for economic progress [...] which from the coastal strip spread both inland and in the sea mirrors." [4] (p. 369).

The 'maritime-coastal region', developed by Vallega, is useful for understanding the changes in the coastal area; he defines it as a special region arranged on two environments, land and sea, profoundly different but which establish integrated forms of occupation and integration of resources. In the following years, the growing awareness of the economic importance of the sea and its immediate hinterland has generated further changes in the evaluation of the role of maritime spaces in territorial organization processes. [5].

The thickness of the coastal strips is a multipurpose concept, which assumes proportions commensurate with the phenomena, parameters and functions under study. More than two simple "joint plans", the coastal areas and the coastal sea, elements that have always exerted a powerful attraction on men, are linked by a network of relationships that thickens and becomes more complex, as human organization becomes more relational. [6].

Historically, coastal regions have played the role of cultural transmission areas, where people, goods and goods and ideas from abroad are mixed with local and traditional ones. Today, cultural heritage plays a central role in the narratives of coastal regions and in their reorganization as places and / or containers of historical, cultural, social and economic principals.

Cultural heritage is, therefore, that part of the past that we select in the present for current purposes whether they are economic, cultural, political, or social. Human interaction with the sea in coastal areas has shaped the natural landscape; it played a crucial role in the formation of the maritime and coastal cultural heritage. Over time, it has promoted the promotion of the sense of identity and attachment to places. [7], [8], [9].

The recovery of territorial signs: lighthouses and other structures

The Italian legislation on cultural heritage has introduced the concept of enhancement and use of cultural heritage for some years by entrusting cultural assistance and hospitality services to the public to third parties. In this direction, since 2015 and in the other three subsequent editions, the national project "Valore Paese" of the State Property Agency has started, which intends to promote the enhancement of the Italian public real estate assets through the synergy between the tourism, art and culture, economic development and territorial cohesion. In this sense, the recovery of public property owned by the state and local authorities has the possibility of being considered no longer only in terms of cost for the community, but also as a significant lever for territorial and social development, in a partnership logic public-private.

In the almost five years since the start of the project, new synergies have been created for the effective implementation of the project; from the cooperation of the central administration with the regions and local authorities and individuals who will request and obtain the concession of use to the agreements for the promotion and use of lighthouses and other coastal structures. New ways of entrusting cultural, hospitality and organizational assistance services were also prepared, also linked to the establishment of mixed companies.

The enhancement of the lighthouses, in particular, concerns the economic relevance of the cultural heritage for the impacts that it transversely determines in relation to its activities and services. The conversion of lighthouses and coastal structures in Italy is comparable to some initiatives similar to the European scale; specifically a similar path started in Spain and Portugal. Even lighthouses like other cultural resources are finally considered as an expression of that system of signs that binds the territory with the economic and social structure of a nation. [10] [11] [12].

In accordance with article 9 of the Italian Constitution ("The Republic promotes the development of culture and scientific and technical research. It protects the landscape and the historical and artistic heritage of the nation"), the Code of Cultural Heritage and Landscape (introduced in 2004 and modified in 2015) set the guiding concepts, such as protection, conservation and enhancement, relating to the thinking and activities on the Italian cultural heritage. The term 'protection' (Art. 3) means any activity aimed at recognizing and conserving an asset of our cultural heritage so that it can be offered to collective knowledge and enjoyment. Conservation is any activity carried out with the aim of maintaining the integrity, identity and functional efficiency of a cultural asset, in a coherent, planned and coordinated manner (Art. 29), and is expressed in the in-depth knowledge of the cultural asset and in limiting the risk situations connected to the cultural asset in its context. Enhancement is any activity aimed at improving the conditions of knowledge and conservation of the cultural heritage and increasing its public use, so as to transmit the values that this heritage bears. Protection is the exclusive competence of the State, which dictates the rules and issues

the administrative measures necessary to guarantee it; the enhancement is carried out concurrently between the state and the region, and also involves the participation of private entities (Art. 6). The enhancement consists in the exercise of the functions and in the discipline of the activities aimed at promoting knowledge of the cultural heritage and ensuring the best conditions of use and public use of the heritage itself. It also includes the promotion and support of cultural heritage conservation interventions. With reference to the landscape, the enhancement also includes the redevelopment of buildings and areas subject to compromised or degraded protection, or the creation of new coherent and integrated landscape values.

With particular reference to the enhancement and redevelopment of properties of landscape value on the Italian territory, the "Valore Paese" Initiative of the Agenzia del Demanio, since 2015, promotes the economic and social value of some state real estate assets (such as villas, historic buildings, castles, prisons, barracks, lighthouses, and more).

The first edition was divided into two macro-projects: Valore Paese for historic houses and Valore Paese for lighthouses; the first was aimed at strengthening the cultural offer and competitiveness of Italy through a strategy of integration between the sectors of tourism, art and culture, economic development and territorial cohesion on the model of the hotel chain of Paradores in Spain and Pousadas in Portugal. By integrating the "Strategic Plan for the Development of Tourism in Italy 2020" and the community programming 2014-2020, the project had the aim of creating a new hotel accommodation system with precise quality standards and dedicated to those tourists more likely to enjoy of local cultural heritage.

The second 'Valore Paese Lighthouse' project was aimed at recovering a part of the public heritage, owned by the state and local authorities, now economically unproductive but with great potential for territorial and social development. [13] [14].

Some of the lighthouses, inhabited by their caretakers until a few years ago, are now in a state of progressive degradation and can be converted and reused in tourist-cultural structures, information points and restaurants. The main purpose of the enhancement process (in its four editions) is to subtract the lighthouses that are in a state of degradation, to start them to regeneration, helping to activate local economies for the benefit of the community. Since 2015, four editions of "Valore Paese Fari" have followed, with the results indicated in table 1.

The enhancement will be operational through the concession of use (after a specific Public announcement) for up to 50 years to operators who present a tourism project with high economic potential useful to the whole territory; however, the concession provides for the maintenance of the public-private partnership.

Until 2015, a similar operation had been tested only for Capo Spartivento, in Sardinia, for which the state property collects a concession fee of 100 000 € per year. In addition, it is estimated that savings for the State can be quantified at 210 000 € per year for ordinary operations, to which must be added the extraordinary safety and protection measures estimated at 400 000 € on average per beacon.

At the same time, the State will collect over 330 thousand euros in annual fees which, in consideration of the different duration of the concessions, will amount to around 6.8 million euros for the entire loan period. The successful bidders will invest around 6 million euros to redevelop the structures and adapt them to their new vocation, with an overall economic impact of around 20 million euros and an estimated occupation of around 100 working units. These data, then, are even more significant if contextualized in the territories where the lighthouses are located.

Table 1 - Results of the past editions of the "Valore Paese" Initiative

Strutture costiere già date in concessione	
Lighthouses	Other structures
1. Punta Cavazzi – Ustica (PA)	1. Castelluccia Tower - Bosco Caggioni, Pulsano (Taranto)
2. Capo Grosso – Isola di Levanzo, Favignana (Trapani).	2. Convent San Domenico Maggiore - Taranto
3. Brucoli - Augusta (Siracusa).	3. Pavilion Punta del Pero - Siracusa
4. Murro di Porco - (Siracusa).	4. Stand Florio - Palermo
5. Punta Imperatore - Forio d'Ischia (Napoli)	5. Isle San Secondo - Laguna di Venezia
6. Capo D'Orso - Maiori (Salerno)	6. Cupo Tower - Corigliano Calabro (Cosenza)
7. San Domino - Isole Tremiti (Foggia)	7. Monte Pucci Tower - Peschici (FG)
8. Spignon (Venezia)	8. Fort Castagneto Carducci - Marina Di Castagneto Carducci (Livorno)
9. Capo Zafferano - Santa Flavia (Palermo)	9. Manor Celestina - Rosignano Marittimo (Livorno)
10. Po di Goro (Ferrara)	10. former Powder Keg Building - Bacoli (Napoli)
11. Semaforo Nuovo - Camogli (Genova)	11. former Onfa Building - Punta Marina (Ravenna)
12. Colle dei Cappuccini (Ancona)	12. Octagon Ca' Roman -Venezia
13. Capo Santa Croce - Augusta (Siracusa)	

Generally, the lighthouse regeneration projects envisaged by the Initiative and other similar ones in other countries, foresee the transformation of the same into tourist reception places. This is true of the thirteen headlights already definitively awarded.

In the Lighthouse of Punta Cavazzi in Ustica, the winning company plans to create, in addition to the lighthouse accommodation model, also a cultural container on the guesthouse model with the function of scientific training, seminars, sporting events, but also a residence for artists, a center visits to the lighthouse and a cultural café to create synergies between research and the island's marine park. Similar are also the projects for the lighthouses of Capo Grosso on the Island of Levanzo (TR), of Brucoli in Augusta (SR), of Murro di Porco in Siracusa, with particular attention, the latter three, also to the dissemination of knowledge local food and wine. The lighthouses that will be managed by the German company Floatel GmbH, specialized in the recovery of lighthouses in Scotland, Spain and Germany, or Punta Imperatore in Forio D'Ischia, Faro di Spignon in Venice and San Domino in the Tremiti Islands will follow a model of "refuge in the lighthouse ", intended as an exclusive and reserved space. An exception is the Lighthouse of Capo D'Orso in Maiori (Salerno), for which the successful company, WWF Oasi Soc. Unipersonale arl, has also planned to organize education, observation and monitoring of biodiversity activities for the dissemination the culture of the environment alongside the spaces for hospitality. The

Lighthouse of Capo Zafferano in Santa Flavia (Palermo) and the Lighthouse of Po di Goro in Ferrara will be transformed into hotels. [16].

Compared to the twelve lighthouses whose award procedures are definitively concluded (the procedures for the concession of the lighthouse of the Tremiti Islands are almost finished), sums can therefore be drawn; overall, the state will collect approximately six billion euros discounted for the fees for the duration of the concessions. This amount will increase as the award procedures are concluded. The concessions, then, have been formalized starting from 2017, therefore the data necessary to understand the effective profitability of the lighthouses transformed into tourist structures will actually be quantifiable in the coming years.

The last lighthouse assigned in concession, in chronological order, is that of Camogli, in the Park of Portofino (Genova). The winning company is New Fari S.r.L which will invest 593 thousand euros for the redevelopment and will manage it for 29 years. The recovery project provides for the enhancement of the structure with a significant contribution of new technologies combined with the extraordinary reception potential that this building complex located on the southern slope can offer, in an exceptionally panoramic point of the Portofino Park (The park has an average turnout annual of about 130 000 admissions). Located at 610 masl on the Portofino Promontory, the Semaforo Nuovo was inaugurated in the late 1800s and remained in operation until the mid-1900s and was then definitively abandoned. The walls towards the sea were black and white checkered to make it easily identifiable from the sea. The location was chosen as a traffic light station for reporting on the sea and on land. Later, in consideration of the frequent mists affecting the summit of Monte di Portofino, for the same purpose, the Semaforo Nuovo was built in the lower area.

Another local initiative for the recovery and enhancement of Italian lighthouses is the Sardinia Region "Orizzonte Fari" Program. This involves the publication of five concession notices for as many coastal lighthouses, in implementation of the cooperation agreement with the program, signed in 2017 between the State Property Agency and the Autonomous Region, aimed at the requalification of the island's maritime-coastal heritage. The disused lighthouses included in this first phase are: Capo Orso in Palau, the signal station of Capo Sperone in Sant'Antioco, the traffic light station of Capo Ferro in Arzachena, the Capo Figari lookout station in Golfo Aranci and Punta Falcone signal station in Santa Teresa di Gallura. The agreement includes a total of 10 lighthouses, towers and coastal buildings, 9 of which are owned by the Region and 1 owned by the State, the Lighthouse of Capo Comino in Siniscola. [15].

Like other processes, even that of the conservation and reuse of cultural resources for tourism purposes, such as lighthouses, cannot take place anywhere in the same way. "Even if there is a logical set of steps to be taken, it may be necessary to make changes to adapt to the conditions, needs, purposes and objectives of the place. These steps, or phases, are not mutually exclusive, as there is the possibility of some degree of overlap. [...] The precise nature of these phases cannot be generalized, since they are subject to variations of different degrees, depending on the circumstances and specific contexts." [3] (p. 79).

The overall success of the reuse of Italian lighthouses will depend on the contextualization of each of the initiatives and on the overall vision that the implementing bodies will have.

Sometimes, even small territorial realities, can benefit, in terms of environmental redevelopment and re-enhancement of the coast, from the restoration of ancient coastal buildings. This is the case of the small seaside resort of Torre Canne di Fasano (Brindisi),

where there is an ancient lighthouse (from 1927). Finally, after more than forty years of progressive abandonment, since 2015 the Municipality of Fasano manages this structure under concession (it is a property owned by the Italian State Property); after several works to make the spaces in front and some interiors usable, it is now a tourist attraction and, together, a meeting place for the local population. (Figures 1 and 2).



Figure 1 - The Lighthouse of Torre Canne before the restoration works. (Source: Ivona, 2010).



Figure 2 - The Lighthouse of Torre Canne after the restoration works. (Source: Ivona, 2016).



Figure 3 - The Lighthouse of Torre Canne today. (Source: Ivona, 2020).

Conclusions

The recovery and reuse of identity artefacts has already been taking place in Italy for several years; this renewed route also includes lighthouses and other coastal buildings, gradually recognized as cultural resources not to be dispersed but rather valorised appropriately. They, like other cultural resources, are finally considered as an expression of that system of signs that binds the territory with the socio-economic structure in which they are present. "Within this conception, the object" cultural good "is not analyzed as such but in its meaning, in the value that is given to it, its value as a sign within social relations. The cultural asset therefore assumes different meanings and roles in different territorial contexts." [17] (p. 356).

These goods, therefore, have a relational value and each good is at the center of a socio-cultural multiplicity of evaluations. The complex of localized cultural heritage constitutes the typical heritage of each place, the elements of which enter or can enter into relationship with each other and with the external, within the framework of a local territorial system. In this way, cultural heritage allows each community to achieve its own identity and this heritage can represent a powerful engine for local development, understood as development based on a self-organized process. All the components of the local heritage therefore favor the continuous reinvention of the territory.

The "Agenzia Paese Fari" Initiative of the State Property Agency was developed with this aim in mind. For some years now, in other countries such as the United States, Canada and others, the lighthouses and other typically abandoned coastal structures have been recovered and reused as prestigious tourist residences, as valuable evidence of history. Many examples are also present in Europe; the Corsewall lighthouse in southern Scotland, built in 1815, is now a luxury hotel; Croatia has undertaken the path of regeneration of the lighthouses for tourism for several years and currently there are numerous historical lighthouses transformed into hotels; the same happened in Brittany and England.

This objective guided the development of the "Valore Paese" Lighthouses Initiative of the Italian State Property Agency. For some years now, in other countries such as the United States, Canada and others, the lighthouses and other typically abandoned coastal structures have been recovered and reused as prestigious tourist residences, as valuable evidence of history. Many examples are also present in Europe; the Corsewall lighthouse in southern Scotland, built in 1815, is now a luxury hotel; Croatia has undertaken the path of regeneration of the lighthouses for tourism for several years and currently there are numerous historical lighthouses transformed into hotels; the same happened in Brittany and England.

The common challenge for all initiatives to reuse cultural resources for purposes other than the original ones is, therefore, how to preserve their cultural and economic value without incurring the risk of making them less attractive. An excess of emphasis in emphasizing their cultural value could result in a museification of the resource. The risk, however, of placing an excess of attention in the production of economic value at the expense of the cultural one could result in a trivialization of the resource itself. The "Valore Paese" Initiative does not seem to generate such a risk, given the generally similar characteristics of all the buildings included in the four calls; that is, reduced spaces for accommodation, geographic location often far from inhabited centers and therefore far from traditional entertainment venues.

Concluding, in the specific case of lighthouses, how to summarize the principle of the conservation of the resource-headlights with that of usability according to the principles of sustainability over time? Some international examples (the aforementioned flagship hotels in Croatia, Scotland, Maine, New England) provide reassurance; where the management of the lighthouses, which have become hotels/accommodation facilities, has continued to be attentive to the conservation of the structure and its surroundings, they have not suffered any loss of cultural or economic value. The careful management of the Italian lighthouses that will be managed will not be limited to the maintenance of the structure alone but also of all the other structures and infrastructures that will be necessary to transform an ancient garrison for the safety of mariners into a reception facility for tourists.

The options were two: the permanent abandonment of those structures no longer useful for the original purpose or a new destination and, therefore, conservation. Moreover, the debate on the role of cultural heritage in coastal areas, in the implementation of appropriate sustainable development strategies, is still very heated not only in Italy. It must consider the coastal heritage as a whole; effective conservation and re-enhancement strategies will be those that will consider each resource an integral part of the overall heritage of the territory examined.

References

- [1] Pittaluga P. (eds) (2018) - *Insedimenti turistici costieri e sostenibilità: Progetti di rigenerazione*, Milano, FrancoAngeli.
- [2] Gillis, J. R. (2012) - *The Human Shore: Seacoasts in History*, University of Chicago Press, Chicago.
- [3] Timothy D.J., Boyd, S. W. (2007) - *Heritage e Turismo*, Milano, Hoepli Editore.
- [4] Vallega A. (1980) - La regione marittimo-litoranea: una nuova categoria di ricerca regionale, *Rivista Geografica Italiana*, LXXXVII, 4, 367 - 385.
- [5] Vallega A. (2003) - The coastal cultural heritage facing coastal management, *Journal of Cultural Heritage*, 4, 5 - 24.
- [6] Zunica M. (1987) - *Lo spazio costiero italiano – Dinamiche fisiche ed umane*, Roma, Levi Editore.
- [7] Sorna K., Pieters M., Van Balen K. (2015) - *Coastal Cultural Heritage: A Resource to Be Included in Integrated Coastal Zone Management*, Ocean & Coastal Management, 118, 110 - 128.
- [8] De Matteis G. (1998) - La geografia dei beni culturali come sapere progettuale, *Rivista Geografica Italiana*, 105, 25 - 35.
- [9] Caldo C., Guarrasi V. (eds) (1994) - *Beni culturali e geografia*, Pàtron, Bologna.
- [10] Carnis L. (2013), The provision of lighthouses services: a political economy perspective, *Public Choice*, 157 (1-2), 51 - 56.
- [11] Coase R. H. (1974) - The Lighthouse in Economics, *The Journal of Law & Economics*, 17 (2), 357 - 376.
- [12] Foldvary F. E. (2003) - *The Lighthouse as a Private-Sector Collective Good*, www.independent.org/publications.
- [13] Ivona A. (2016) - Fari dismessi. Dall'abbandono alla rigenerazione, *Annali del Turismo*, 1, 93 - 110.

- [14] Ivona A. (2018) - *I Fari, nuove risorse per i territori*, Cammino dei Fari Italiani. Atti del Primo Convegno Nazionale. Bari – 28 settembre 2018, Adda Editore, Bari, pp. 38 - 41.
- [15] Ivona A. (2019) - *Scelte geoeconomiche per la valorizzazione del territorio. Opportunità e vincoli dall'entroterra al mare*, Bari, WIP Edizioni.
- [16] Agenzia del Demanio (2020) - *Valore Paese Fari*, 2020, www.agenziademanio.it.
- [17] Pioletti A. M. (2002) - *Valorizzazione territoriale e identità locale*. in Persi P. (eds) Beni Culturali Territoriali Regionali. Siti, ville e sedi rurali di residenza, culto, lavoro tra ricerca e didattica, Grapho 5, Fano, pp. 355 - 364.

DISCOVERING THE MARINA'S CULTURAL HERITAGE AND CULTURAL LANDSCAPE

Ricardo Martín¹, Víctor Yepes², Alejandro Grindlay³

¹School of Civil Engineering, Universitat Politècnica de València, 46022 Valencia (Spain)

phone +34 369 879563, e-mail: rimarpo@doctor.upv.es

² ICITECH, Universitat Politècnica de València (Spain)

³Department of Urban and Spatial Planning, University of Granada (Spain)

Abstract – This paper explores the marinas' cultural heritage and it attempts to deep into the relationship between their cultural heritage and cultural landscape. Landscape and heritage are relevant elements in these areas and could be competitive advantages in the management of these maritime facilities.

As facilities for maritime pleasant activities there are many possibilities of identifying their culture heritage and cultural landscape. It is through the analysis of these concepts which is developed the study of the proposed relationship between cultural heritage, cultural landscape, and marinas.

Therefore, they are identified some elements to consider within marinas' cultural heritage and their cultural landscape, not only related to the conservation and re-utilization of elements from the past. And it is also proposed three relationship models, ranging from integration, to strengthen and evolution.

Introduction

Marina is a word coined by the National Association of Engines and Boats Manufacturers in 1928 [10], and it comprises a variety of designs and services, both for vessels and their crew, and also for visitors [1]. In a general meaning, a marina can be defined as a recreational boat facility serving pleasure craft [15], [35], [40], not only as a parking place for boats—berthing facilities—but also for amenity purposes, including entertainment and leisure facilities [1], [19], [36].

The contemplation of a pleasant environment acquires great importance in achieving a leisure character. Environmental quality and scenic views became main topics for economic benefits of marinas [27], [39]. Thus, high aesthetic, historic and cultural resources, and a unique environment represents issues to consider for marina manager. Cultural and heritage resources have been studied in commercial ports, specially dealing with derelict industrial port areas and urban waterfront revitalizations [4], [14], [29], [38], [41]. Focusing on marinas, scholarship have analyse then from diverse viewpoint, such as its relationship with nautical tourism [22], [26], its environment [18], [30], or its layout and shape [8], [32]. But landscape has seldom taken into account [27].

This paper explores the marinas' cultural and heritage landscape, and it attempts to deep into the relationship between their cultural heritage and cultural landscape. Landscape and heritage are relevant elements in these areas and could be competitive advantages in management of these maritime facilities. Firstly, we introduce what landscape means within

a marina, which drives to consider the cultural and heritage landscape in this context. This constitutes the basis to introduce the relationship models with dealing with these topics.

Landscape and marina

Landscape is a relationship between people and their environment [28], [47]. Its significance has its roots in art and it has acquired greater significance along its evolution [43], [48]. During this development, all the different meanings have been integrated in the same concept. It may cause confusion in interpreting the expression, making difficult to manage [6]. Landscape is an ambiguous concept, associated to both to the perception of place by people, and to refer to a particular reality differentiable from the rest [42]; [5]. Firstly, it is perceived as an abstract concept, as a kind of background or set of a picture — nature, surround, environment— which produces sensations who observed [47]. Second, it is related to the particular characteristics that difference from others [5]. Landscape encompasses natural and cultural, past and present, and tangible and intangible features [7], [13], which may range from a mood, a feeling, to analysis through a scientific and analytical approach, establishing common features applicable to a territory. All these components must be considered simultaneously in their interrelations, forming a whole [11], [33] and therefore, it is a holistic, relativistic and dynamic concept [5], [31]. Landscape is an element which appears, either directly or indirectly, in various international legal texts. Nevertheless, it was not until 2000 when an international convention addresses this issue specifically. The European Landscape Convention (ELC), signed on 20 October 2000, defines landscape as «an area, as perceived by people, whose character is the result of the action and interaction of natural and/or human factors» [12]. Until then, landscape had tried intuitively, recognizing the need to preserve the environment as a guarantor of maintaining the quality of life of people, but in a biased and sectorial manner, focussing firstly safeguarding outstanding areas of natural beauty, with a traditional protectionist stance of nature conservation [34].

Martín and Yepes [27] suggest a landscape approach to marinas dealing with their attributes in a transdisciplinary way. They use the hierarchical approach theory as a way of breaking down complexity and to identify patterns and processes by layering the multiple topics that are embodied within landscape. Landscape can be perceived as a nested hierarchy in which different levels correspond to functional units at distinct spatial scales.

The authors consider three hierarchical stages, including territorial, local and inner level. First one is grounded on integrated coastal management, highlighting those aspects related with their location: causes of their location, coastal affection and future incidences. Second level encompasses the relationship with their environment, both physical and emotional. In this stage, the balance between external flows and port operability is one of the main subjects, and it is conditioned by the degree of overlapping. Finally, the inner level is critical from the point of view of the observer, which is located within the infrastructure itself. This is not a closed framework, but a starting point for managers to consider the landscape within the management of marinas.

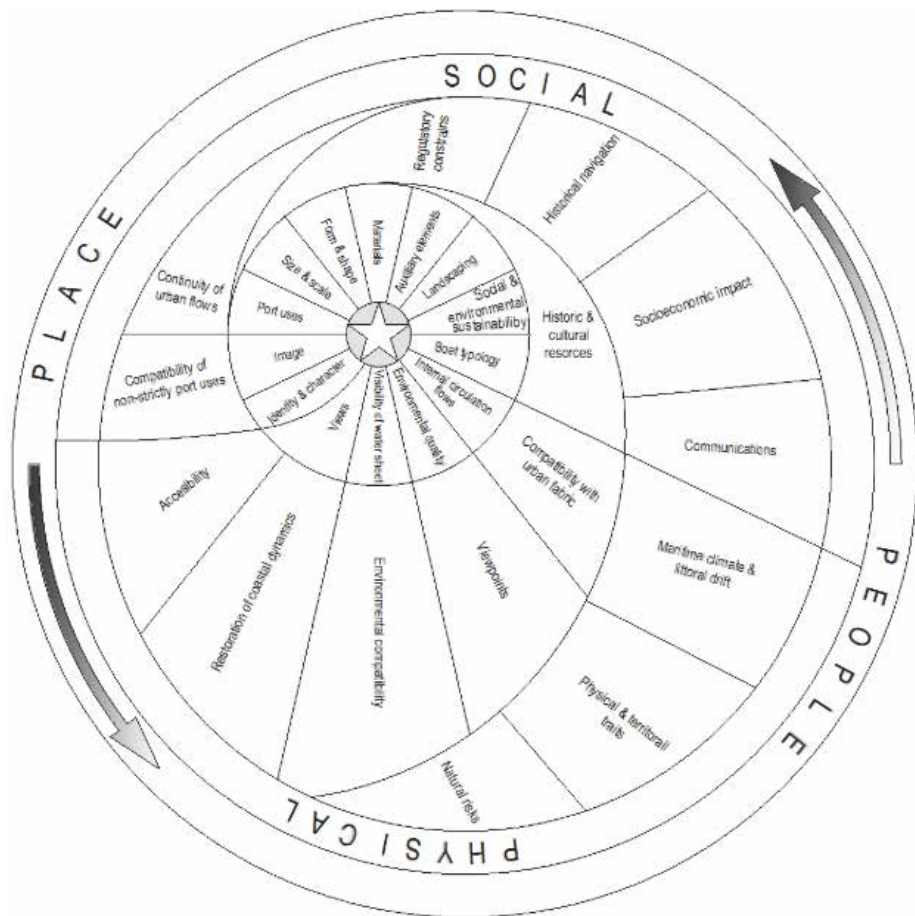

Figure 1 - Components of landscape within marinas [27].

Port cultural landscape and marinas

Cultural landscapes represent the «combined works of nature and man». This definition given by UNESCO [49] collects the term coined by Sauer [46] in the earlier 20th century: «cultural landscape is fashioned from a natural landscape by a culture group. Culture is the agent, the natural area the medium, the cultural landscape the result». Early reports addressed on historical studies and since the late 1980s were introduced understanding of the complexity of these terms, involving an expanded scope intending to provide a multidisciplinary effort. But it was until the 1990s when «cultural landscape» was adopted as a conservation category when World Heritage Committee of UNESCO agreed in 1992 on revised operational guidelines specifying that cultural landscapes could be protected in accordance with the World Heritage Convention of 1972 [3], [20]. Cultural landscape

reflects the social changes and attitude towards its surroundings, relating both natural processes and social processes [5], [21]. The cultural landscape reflects changes in the interconnections between society and the environment [21], [44] and it is a reflection of fear the threat of decreasing of aesthetics and cultural-historical values facing the progress of economic development [49], [21].

Cultural landscape concept has several connotations at the same time and different disciplines have used it in different ways [20]. Within this ambiguity, infrastructure can be considered as a cultural landscape. All infrastructure is imbued with a cultural quality not only because interacts natural and social environment but it is also a reflection of technical expertise and, at times, of a sensibility, which makes these actions not only expose the solution to a difficulty, but how that this problem is addressed [2], [29], which takes on not only social but also cultural dimension.

Focusing on ports, shelter is suited for maritime activity necessity. People transform the coastal environment to adapt shore line with lack of shelter to these requirements, reflecting existing knowledge and according to needs and construction techniques. However, if we analyse the construction methods for ports pointed out in various old treaty and studies [24], [51] it follows that techniques have been progressing, and not that proper procedure. The conceptual basis is the same, varying the applied technologies in each period seeking of a maximum throughput. As summarized by Diedrich [16], *«harbours can be addressed as very specific sites at precise moments in time. The landscape perspective allows us to perceive harbours as result of a particular culture, as cultural goods»*. However, the port is an element that can hold and bring together various activities, so it is the container, varying their contents. The specific requirements of these activities have accumulated distinctive feature that clearly distinguish from the rest of its urban surrounding [41]. It results in a dual port cultural landscape treatment: the container (infrastructure) and the content (activity).

From the viewpoint of the container, the port reflects landscape the degree of knowledge of coastal phenomena, the construction techniques available in each moment and construction procedures used to overcome adversity.

Focusing on the content, the nature of this activity is developed which gives the space a particular culture and therefore conforms corresponding landscape. We also must consider the constraints given by the conditions of the security, operability and functionality of inner activities.

Related to marinas, the tourist or recreational adjective to this kind of ports has a connotation to pleasure, containing all the services required for comfortable stay [50]. But this should not harm its technical qualities that marina has to maintain, and the nature of the relationship with its environment. The playful nature of this activity and the lack of a mark acquired by a minor temporal course involve several obstacles in creating a particular identity. The main obstacles for a marina to overcome when achieving a cultural character are: (1) to avoid mere craft-berthing, (2) the adoption of monotonous and anodyne solutions in relation to the immensity of the coast in which they are inserted, and (3) the lack of links to their environment [27]. Marinas should aspire to be attractive sources of their surroundings where to interact and to share experiences [23], [52].

Port cultural heritage landscape and marinas

In 1992, the scope of the Convention for the Protection of the World Cultural and Natural Heritage was broadened to allow the cultural landscapes to be included in the World Heritage List. Therefore, cultural landscapes with an outstanding and universal quality can cross the cultural character achieving a heritage one.

Historically, ports provide attractiveness to their surroundings from ancient times [24], [27]. This drives to a set of relationships that have been woven and that take place in their urban and territorial environments with the particularity of a singular space (interface between land and water). The persistence of port activity in one place over time provides archaeological bases that are grounds for granting a patrimonial character to that port. In this sense, several authors have explored the archaeological value of existing ports [37], [38]. Ports are able to store singular elements and structures, such as old buildings, lighthouses or cranes, as well as, signs of different materials and periods. The preservation of these elements represents an opportunity to take advantage for the valuation of port spaces [17].

There is a huge diversity for the treatment of heritage elements in port areas. The recuperation and maintenance of old port infrastructures for its integration in the redevelopment process, and the conservation and maintenance but displaced from their original sites are examples of these processes.

Nevertheless, we can find some constraints when dealing with port heritage. Firstly, the operations of recovery this heritage are limited by their financial return [45]. Secondly, it is necessary to identify and recognize the real value of these elements [38]. Finally, the difficulty to find solutions that match the compatibility between the element to be retained and the alternatives of use and development.

Several actual marinas have their origin in old fishing ports and also occupy the space that has been leaving port activity that has been declining (fishing or industrial), or share the port space with such activities. Throughout the development of the ports, the change in their uses and functions has been determining links with socio-cultural and economic factors, remaining cultural elements that determine the importance of this heritage.

Relationship models

When considering landscape of marinas, the image of the marina and the water acquire great importance. Nevertheless, the most valued criteria are the compatibility with the environment, the historic and cultural resources, and those which provide identity and character to the space [27]. Above exposed points out two main ideas related to culture and heritage: (a) both are main element when analysing marina's landscape; and (b) they are related with the character of the marina.

The character must be taken into account when dealing with marina's landscape. It can be described as «*a distinct recognisable and consistent pattern of elements in the landscape that makes one landscape different from another*» [47]. It is necessary to note that the character of a port refers to uniqueness, so it can be seen as unique entity with own identity [25]. In this sense, the concept of searching for an identity there is always the risk of replicating an existing concept, repeating a solution that transforms the space into a thematic space whose unique purpose is its image [9]. And there is also an absence of representing the

environment of cultural values, being independent of the place of its location, without obligation of meaning or representation, not consumer oriented meeting place but its image.

Cultural landscape reflects the social changes and attitude towards its surroundings. It relates the interconnections between society and the environment, and it is a reflection of fear the threat of decreasing of aesthetics and cultural-historical values facing the progress of economic development. Although all landscapes include cultural values, not all of them can be considered as cultural landscapes. It needs a singular association between nature and man that clearly identifies a culture: the landscape as a reflection of the action of a particular community on the territory.

Cultural heritage landscape is a superior stage from cultural landscape. It represents a cultural validity sustained over an ample period of time, and a recognised value. This designation derives from different institutions or organisms, at international or state level. And the nature of the framework that supports such designation may be support by a mandatory regulation or voluntary follow-up guidelines. This nature will provide the importance of the considered distinction. Cultural heritage always gives and adds value to the landscape. Cultural heritage cannot be conceived without its surroundings, and adjacent landscape help to delimitate and protect this heritage. The improvement of the cultural heritage has a favourable benefit over the landscape where it is inserted.

Therefore, despite their recent existence in general, some elements to consider within marinas' cultural heritage and their cultural landscape are identified, not only related to the conservation and re-utilization of elements from the past. And it is proposed three relationship models: integration, ranging from integration, to strengthen and evolution. These relationships depend on the relative weight between the marina's landscape and the component of the culture/heritage landscape.

Integration occurs when there is previous culture, and the weighted value of the last one is higher than the first one. The existences of a heritage site (old port) or an important previous culture (e.g. fishing culture) are examples of this relationship. In this case, the marina must integrate within the environment, becoming part of it without creating alterations or distortions. In any case, the marina should contribute to the promotion and support of this cultural heritage.

Strengthen is similar to previous one. There is a previous culture of heritage, but the relative weight of the marina's landscape is higher. The existences of a single historic building or feature (e.g. ancient fish market or lighthouse) are integrated in this case. The element considered is modified so that it can perform different functions, for which it was initially built, but retaining its aesthetics and historical value. The reuse of historic buildings is an important way to create new relationships between the city and the waterfront, and a strategy of adaptation.

Evolution is considered when some of the conditions that define the cultural/heritage character are not met. So, the marina managers must strengthen these aspects so that, over time, the marina can lead to this status.

Focusing on cultural heritage landscape, it is possible to identify a set of landscapes from across the experience:

World Heritage List. It is a designation for places with outstanding universal values to humanity that must be protected for future generations. This international distinction given by UNESCO implies a protection and management requirements. The Maritime Mercantile City of Liverpool (UK), the Port of Cartagena de India (VE), the Old

Port harbour of Dubrovnik (HR), and the harbour of Valparaíso (CL) are examples of these singular elements. Marinas can be embodied into these singular places and they are platforms to appreciate and enjoy their uniqueness.

Archaeological sites. It is a place where there are physical remains of past human activities. Ports are reflection of construction technology, transport systems and port management in different periods. These elements must be preserved as footprints of the port activity and its identity.

Protected elements based on heritage register. This set can identify different categories of protection depending on the kind of relevance, uniqueness or cultural value. So, bellowed items may be considered as ones of the most important categories to be considered.

These models are relevant in the consideration of the cultural heritage and cultural landscape of marinas.

Conclusions

The landscape represents a competitive advantage within the management of marinas. Among the elements that make up this landscape, cultural and historical resources are main topics, which also enhance the identity and character of the marina.

It is necessary to carry out an identification and evaluation of the cultural and patrimonial elements that embrace the port space. The subsequent analysis of the relationships of these elements within their environment provides a powerful tool for the establishment of strategies that enhance the image of the marina and its environment, and also providing the relationship between both. Moreover, the consideration of cultural and cultural heritage landscape represents an opportunity to improve the management of the marina and its surroundings.

References

- [1] Adie, D.W. (1984) - *Marinas. A Working Guide to their Development and Design*, The Architectural Press Ltd, London.
- [2] Aguiló, M. (1999) - *El paisaje construido. Una aproximación a la idea de lugar (The landscape built. An approximation to the idea of place)*, Colegio de Ingenieros de Caminos, Canales y Puertos, Madrid.
- [3] Aitchison, J. (1995) - *Cultural landscapes in Europe: a geographical perspective*, in Von Droste, B., Plachter, H., Rossley, M. (Eds.) - *Cultural landscapes of universal value*. Gustav Fisher, Verlag, Stuttgart & New York, pp. 272-288.
- [4] Alemany, J., Bruttomesso, R. (2011) (Eds.) - *The port city. New Challenges in the Relationship between Port and City*, Rete, Venice.
- [5] Antrop, M. (2000) - *Background concepts for integrated landscape analysis*, Agriculture, Ecosystems and Environment, 77(1-2), 17-28.
- [6] Antrop, M. (1997) - *The concept of traditional landscapes as a base for landscape evolution and planning. The example of Flanders Regions*, Landscape and Urban Planning, 38(1-2), 105-117.
- [7] Antonson, H., Åkerskog, A. (2015) - *"This is what we did last lime". Uncertainty*

- over landscape analysis and its procurement in the Swedish road planning process, *Land Use Policy*, 42, 48-57.
- [8] Apicella, M., Benassai, E., Di Natale, M., Panelli, E. (1991) - *An example of possible innovations in Mediterranean marina design*, *Marine Pollution Bulletin*, 23(C), 403-410.
- [9] Ashworth, G., Page, S.J. (2011) – *Urban tourism research: Recent progress and current paradoxes*, *Tourism Management*, 32(1), 1-5.
- [10] Chaney, C.A. (1961) - *Marinas. Recommendations for Design, Construction and Maintenance*, National Association of Engine and Boat Manufacturers, Inc., New York.
- [11] Council of Europe (2008) - *Recommendation CM/Rec(2008)3 of the Committee of Ministers to member states on the guidelines of the implementation of the European Landscape Convention*. Retrieved from <https://rm.coe.int/16802f80c9> (accessed 15 May 2016).
- [12] Council of Europe (2000a) - *European Landscape Convention*. Florence, CETS N° 176. Retrieved from <https://rm.coe.int/CoERMPublicCommonSearchServices/DisplayDCTMContent?documentId=0900001680080621> (accessed 15 May 2016).
- [13] Council of Europe (2000b) - *European Landscape Convention. Explanatory Report. COETSER 2*. Retrieved from <https://rm.coe.int/CoERMPublicCommonSearchServices/DisplayDCTMContent?documentId=09000016800cce47> (accessed 15 May 2016).
- [14] De Rosa, F., Di Palma, M. (2013) - *Historic urban landscape approach and port cities regeneration: Naples between identity and outlook*, *Sustainability*, 5, 4268-4287.
- [15] Diakomihalis, M.N. (2007). Chapter 13 Greek Maritime Tourism: Evolution, Structures and Prospects. *Research in Transportation Economics*, 21, 419-455.
- [16] Diedrich, L.B. (2012) - *Traslating Harbourscapes. Site-specific Design Approaches in Contemporary European Harbour Transformation* (PhD Thesis). Department of Geosciences and Natural Resource Management, University of Copenhagen.
- [17] Grindlay, A., Bestué-Cardiel, I., Rodríguez-Rojas, M. (2018) – *Port heritage in city-port transformations: opportunities or constraints?*, *Proceedings of the 6th International Conference on Heritage and Sustainable Development*, Granada, Spain, 12-15 June 2018, pp. 1339-1349.
- [18] Gómez, A.G., Ondiviela, B., Fernández, M., Juanes, J.A. (2016) - *Atlas of susceptibility to pollution in marinas. Application to the Spanish coast*, *Marine Pollution Bulletin*, 114(1), 239-246.
- [19] Heron, R., Juju, W. (2012) - *The Marina: Sustainable Solutions for a Profitable Business*. Create Space Independent Publishing.
- [20] Jones, M. (2003) - *The concept of cultural landscape: discourse and narratives*, in Palang, H., Fry, G. (Eds.) - *Landscape interfaces. Cultural Heritage in Changing Landscapes*, Kluwer Academic Publishers, Dordrecht, Boston, London, pp. 21-51.
- [21] Jones, M., Daugstad, K. (1997) - *Usages of the “cultural landscape” concept in Norwegian and Nordi*, *Landscape Administration. Landscape Research*, 22 (3), 267-281.
- [22] Jugović, A., Kovačić, M., Hadžić, A. (2011) - *Sustainable development model for nautical tourism ports*, *Tourism and Hospitality Management*, 17(2), 175-186.

- [23] Kato, H. (2018) – *Elements to foster friendly relationships between ports and towns. Photo analysis over boundaries and over time*, WIT Transaction on Ecology and the Environment, 227, 31-42.
- [24] Keller, A. (1996) - *The Twenty-One Books of Engineering and Machines of Juanelo Turriano (1501-1575). A traslation of the manuscript in the National Library*, Fundación Juanelo Turriano, Madrid.
- [25] Loupa, I., Bernardo, F., Carvalho, S., Van Eetvelde, V. (2016) - *Landscape identity: Implications for policy making*, Land Use Policy, 53, 36-43.
- [26] Luković, T. (Ed.) (2013) - *Nautical Tourism*, CAB International, Oxfordshire & Boston.
- [27] Martín, R., Yepes, V. (2019) - *The concept of landscape within marinas: Basis for consideration in the management*. Ocean & Coastal Management, 179, 104815. <https://doi.org/10.1016/j.ocecoaman.2019.104815>
- [28] Martín, R., Yepes, V. (2017) - *El paisaje en la planificación y gestión de los puertos deportivos en Andalucía (The landsape in the planning and management of marinas in Andalucía)*, Revista de Obras Públicas, 164 (3593), 38-55.
- [29] Meyer, H. (1999) - *City and Port: Urban Planning as a Cultural Venture in London, Barcelona, New York, and Rotterdam*, International Books, Rotterdam.
- [30] Misic, C., Covazzi Harriague, A. (2009) - *Organic matter characterisation and turnover in the sediment and seawater of a touristic harbor*, Marina Environment Research, 68, 227-235.
- [31] Naveh, Z. (2001) - *Ten major premises for a holistic conception of multifunctional landscapes*, Landscape and Urban Planning, 57(3-4), 269-284.
- [32] Negro, V (2008) - *Las formas en la ingeniería del mar (The shapes in the engineering of the sea)*, Ingeniería y Territorio, II, 87, 4-9.
- [33] Olwig, K.R. (2007) - *The practice of landscape 'Conventions' and the just landscape: The case of the European Landscape Convention*, Landscape Research, 32(5), 579-594.
- [34] Olwig, K.F., Olwig, K. (1972) - *Underdevelopment and the development of "natural" park ideology*, Antipode, 11(2), 16-25.
- [35] Orams, M. (1999) - *Marine Tourism: Development, Impacts and Management*, Routledge, London & New York
- [36] Paker, N., Vural, C.A. (2016) - *Customer segmentation for marinas: Evaluating marinas as destinations*, Tourism Management, 56, 156-171.
- [37] Parker, A.J. (1999) - *A maritime cultural landscape: the port of Bristol in the Middle Ages*, The International Journal of Nautical Archaeology, 28(4), 323-342.
- [38] Peñalver, M.J., Maciá, J.F. Galiana, M., Segado, F. (2013) – *Port city waterfronts, a forgotten underwater cultural heritage. The materials used to build the port of Cartagena (18th century)*, Journal of Cultural Heritage, 14(3), e15-e20.
- [39] Petrosillo, I., Valente, D., Zaccarelli, N., Zurlini, G. (2009) - *Managing tourist harbors: Are managers aware of the real environmental risks?*, Marine Pollution Bulletin, 58(10), 1454-1461.
- [40] PIANC (1976) - *Final report of the International Commission for Sport and Pleasure Navigation*. Annex to bulletin 25 (III), Brussels.
- [41] Pinder, D. (2003) - *Seaport decline and cultural heritage sustainability issues in the UK coastal zone*, Journal of Cultural Heritage, 4(1), 35-47.

- [42] Ramos, A., Aguló, M. (1988) - *The landscape of water: Introduction*, Landscape and Urban Planning, 16(1-2), 1-11.
- [43] Roger, A. (1997) - *Court traité du paysage (Brief treatise on the landscape)*, Gallimard, Paris.
- [44] Russell, E.W.B. (1997) - *People and the land through time: linking ecology and history*, Yale University Press, New Haven & London.
- [45] Shaw, B. (2001) – History at the water’s edge. In Marshall, R. (Ed.) – *Waterfront in Post-industrial Cities*. Spon Press, London, pp. 160-172.
- [46] Sauer, C.O. (1925) - *The Morphology of Landscape*. University of California Publications in Geography, 2, 19-54.
- [47] Swanwick, C. (2002) - *Landscape Character Assessment. Guidance for England and Scotland*. The countryside Agency-Scottish Natural Heritage. Retrieved from <https://www.nature.scot/landscape-character-assessment-guidance-england-and-scotland> (accessed 14 October 2005)
- [48] Tress, B., Tress, G. (2001) - *Capitalising on multiplicity: a transdisciplinary systems approach to landscape research*, Landscape and Urban Planning, 57(3-4), 143-157.
- [49] UNESCO (1972) - *Convention Concerning the Protection of the World Cultural and Natural Heritage*. United Nations Educational, Scientific and Cultural Organization. Paris, 16 November 1972. Retrieved from <http://whc.unesco.org/en/conventiontext/> (accessed 16 May 2016).
- [50] Vieville, B. (1972) - *La clientele des ports de plaisance de la Côte d'Azur, Méditerranée*, 11 (3-4), 19-38.
- [51] Viguera, M., Peña, J. (2000) - *Evolución de las tecnologías de las infraestructuras marítimas en los puertos españoles (Evolution of the the maritime infrastructure technologies in Spanish ports)*. Fundación Portuaria, Madrid.
- [52] Viola, P. (2005) - *Porti turistici: una disciplina e una sfida (Marinas: a discipline and a challenge)*, Portus, 9 (5), 14-21.

EVALUATION AND MONITORING OF THE LIVORNO'S FOSSI SYSTEM

Laura Montioni¹, Andrea Del Corona², Isabella Palano³,
Francesca Pichi⁴, Matteo Scamporrino⁵

¹Università degli Studi di Firenze, Via della Mattonaia 14, 50121 Florence (Italy)
phone +39 331 4344610, e-mail: laura.montioni@stud.unifi.it

²Autorità di Sistema Portuale Mar Tirreno Settentrionale Direzione Pianificazione, Scali Rosciano
6/7, 57123 Livorno (Italy), phone 0586 249411, e-mail: a.delcorona@portaltotirreno.it

³Università degli Studi di Firenze, Via della Mattonaia 14, 50121 Florence (Italy)
phone +39 348 8306371, e-mail: isabella.palano@stud.unifi.it

⁴Autorità di Sistema Portuale Mar Tirreno Settentrionale Direzione Pianificazione, Scali Rosciano 6/7
57123 Livorno (Italy), phone 0586 249411, e-mail: f.pichi@portaltotirreno.it

⁵Università degli Studi di Firenze, Via della Mattonaia 14, 50121 Florence (Italy)
phone +39 339 2218196, e-mail: matteo.scamporrino@unifi.it

Abstract – The ditches and canals of Livorno, also called Fossi, are the most characterized elements the city, not only from a historical point of view, but also and above all from an urban landscape characterization point of view. Currently the canals are used as moorings for boats and along the circuit there are many nautical circles; but the use as a waterway, or as a functional element of the city, is made difficult by some solutions not fully in line with optimal safety standards. The importance of the Livorno's Fossi system is fundamental because they are a place of aggregation before circulation. Despite this relevance for the city and its inhabitants, the state of conservation and maintenance is not adequate for use.

Central theme and hypothesis - Due to the overlapping of skills not yet resolved, fragmented information and data exist regarding the real extent of the pleasure craft, the status of the canals, the provision of services and general safety. On the stimulus of the Tuscany Region, the Northern Tyrrhenian Sea AdSP has started the first monitoring of the pleasure craft in the Livorno's Fossi system with an assessment of possible future scenarios. The hypothesis is to succeed, through a multi-criteria assessment of scenarios, to support and quantify the displacement of vessels that negatively affect safety, accessibility and the landscape of Livorno's Fossi system elsewhere.

Methodology - This work started with the analysis of the Livorno's Fossi system. The aim is to explore tools and scenarios useful for the re-functioning and safety of the ditches. In the first phase, an aerophoto monitoring of the Fossi system will allow to pull out the counting and characterization of the boats, as well as the mapping of the concessions. The results are then collected maps, trying to objectify and explain the qualitative and quantitative setting system, called Scenario 0. This scenario highlights the weaknesses of the current system. Starting from scenario 0, the navigation safety parameters contained in the PIANC guidelines, scenario 1, will be applied first; a further scenario will instead follow the landscape and cultural criteria, freeing the most significant historical-identity areas from the boats, scenario 2; finally a hybrid scenario between the last two, scenario 3. All the scenarios will be assessed according to environmental, landscape, socio-economic and navigation safety indicators.

Expected outcomes - Thanks to the quantification and punctual evaluation of the monitoring, being able to have a plan of displacements useful for the planning of a new landing place for pleasure boats that negatively affect the Livorno's Fossi system.

A brief historical introduction

The system of ditches and canals of Livorno is closely linked to the history and growth of the city. Livorno was geographically located at the southern part of a large lagoon, now entirely filled, which stretched from Massaciuccoli to the reliefs of Montenero. Thanks to its strategic position, the area was home to the Porto Pisano, one of the main ports in the Mediterranean. Over the centuries, the Port was fortified with the construction of numerous towers that determined its typical appearance. In the central centuries of the Middle Ages, the progressive burial of the Porto Pisano determined the rise of the reality of Livorno. In 1300 a real fortress was built by Pisa connecting the pre-existing towers through a quadrilateral structure. The new fortress then took the name of “Quadratura dei Pisani” and formed the nucleus of the current Fortezza Vecchia.

The rise of the Medici family, who obtained stable and legitimate control of the complete region in 1530, greatly influenced the development of the city of Livorno as a new strategic landing place for Florence. In 1519 Antonio da Sangallo designed the fortress incorporating the Quadratura dei Pisani. In 1522 work was started on the moat that would isolate the new construction, demolishing part of the medieval residential fabric. The construction of the new fortress was functional both to the new military requirements and to the protection of the seaport and it represented the first step of an urban planning strongly desired by the political leadership. The act of foundation of the new city dates to the year 1537. Cosimo I proposed to strengthen the Livorno port as a centre of storage and exchange between Mediterranean and the ports of Northern Europe.

Bernardo Buontalenti was commissioned to design the new city. The design envisaged a pentagonal city wall extending for five kilometres, connected to a large system of ditches for its protection and communicating with the sea. Buontalenti's project underwent profound rethinking and transformations in its implementation because it had not declined in detail all the aspects related to the needs of the emerging merchant class. The design of the city border determined by the bastions was influenced by the economic crisis, which overwhelmed the Grand Duchy of Tuscany at the end of the 16th century and in the first decades of the 17th, and by the Grand Duke's decision to build a second fortification on the mainland side, the Fortezza Nuova, designed at the same time as the reorganization of the arrival area of the Navicelli Canal. The Navicelli Canal connected the port of Livorno with the cities of Pisa and Florence. The completion of the Canal, together with the approval in 1566 of the new customs regulations, are some of the actions taken to relaunch the landing as an international seaport. The new customs rules and the strengthening of the warehouse port changed the relationship between the city and the sea. The flourishing economy of maritime trade and the changing defensive needs of the city led to the creation of two urban increases at the expense of the original Fortezza Nuova that led to a new configuration of the urban quadrant of the northeast, with a very strong port commercial connotation. In the first decades of the 17th century the urbanization of the filling land between the sea and the Navicelli canal took place. The district built here took the name Venezia Nuova because of

its construction, on piling foundations, were probably called Venetian workers. At the end of the same century, the new urban district experienced a further important growth, through the demilitarisation and transformation of part of the imposing Fortezza Nuova. In this way, valuable spaces were made available to merchants because of their location closely connected to the port by canals. With the urbanization of Venezia Nuova, Livorno took on the appearance of a city on the water, with canals, bridges, ports of call and cellars on the level of the ditches, projecting the port area into the city: in short, the fully merchant city was born, in which the sea penetrated deeply into the hinterland through the network of canals.

In the 1830s the expansion of the city beyond the fortified walls accelerated rapidly, with an increase in the number of residents in the eastern part of the settlement. To reunite the old city with the new one, the bastions were demolished and the Fosso Reale was rectified. A large bridge was built on the Fosso Reale, called 'Voltone', which served as a link between the Medici city and the Lorena expansion. The commercial role of the ditches became more and more marginalized throughout the 20th century, as the role of waterway disappeared due to the effects of the modernization of the logistics linked to the port activities. It was only in the second half of the 20th century, with the development of the pleasure boating sector and popular sports activities, that ditches found a new role, such as venues and facilities for nautical sports, sports fishing clubs or art workshops.

Central theme and hypothesis

Fossi and canals of Livorno are the element that most characterizes the city. Not only from the historical point of view, but especially for the urban landscape characterization. Currently Fossi are used as mooring for boats; along the circuit there are numerous nautical clubs. The use of the ditches as a waterway, or as a functional element of the city, is made difficult by some solutions and *de facto* uses not fully in line with optimal safety standards. The aim of this work is to explore tools and scenarios useful for the re-functionalisation and safety of the ditches. The reconnaissance has been stimulated by the Region of Tuscany and by the requests for the updating of the Conscious Framework of the Masterplan of Ports.

In a first phase a simple reconnaissance of the Fossi system was carried out, through the counting and characterization of the boats, as well as the mapping of the concessions. The analysis was based on the mapping of the vessels moored along the perimeter of the ditches, canals and docks of the marina, also taking into account the concession areas. The map of concessions was provided by AdSP for the year 2019 in .shp format. Further cartographic bases used were the three orthophotos relating to the years 2010, 2013 and 2016, available on the Geoscopio portal of the Region of Tuscany. The vessels were then counted and categorised within the various concessions. The analysis stimulated the search for an analytical method for the reorganization of the system. To collect data in a consistent and functional way, it was decided to divide the circuit into 17 stretches and to draw up a datasheet for each one. To divide the Fossi's path, bridges were used as boundaries instead of concessions limits, so the division was clearer and more intuitive. In the paper, for the sake of brevity, only the images and analyses of stretch 16 are reported. Stretch 16 is circumscribed between Via Augusto Novelli and Piazza Cavour.



Figure 1 - Ortophoto stretch 16, between Via Augusto Novelli and Piazza Cavour.

Methodology

The first step for the realization of a scientific method to study the distribution of boats along the Fossi circuit was to analyze the size of the canals. Evaluating the size of the Fossi sections seemed to be an impossible mission without an *ad hoc* survey campaign. By studying the functions of QGIS instead, it was possible to evaluate the size of the section.



Figure 2 - Sections along stretch 16.

First, the ctr (regional certified map) was used in shapefile (.shp) format and ditches' axis was drawn to create the sections. On the axis, a step of 5 meters was established in order to identify the remarkable points where to draw the sections. Then, thanks to a function that allows to calculate the minimum distance (perpendicular) between two lines, the distances between the axis and the edge of the ditch were calculated, thus obtaining the measurement for each remarkable point identified. The scanning of the 5 meters was then simplified and rationalized. The width of the ditch is therefore considered to be estimated: since it does not derive from a measured survey, but being based on certified cartographic data, it can be considered true and with a tolerance of less than decimeters.

Table 1 - Estimated width of each section along stretch 16.

Section	Estimated width (m)
1	24,4
2	24,4
3	24,3
4	24,3
5	24,3
6	24,2
7	25,2
8	26,2
9	27,1
10	28,1
11	29,0
12	28,9
13	28,9
14	28,9
15	28,8
16	28,8
17	28,9
18	31,1
19	31,1
20	31,0
21	31,0
22	31,0
23	30,9
24	30,9
25	21,9
26	21,9
27	21,9
28	22,0
29	22,0
30	19,1
31	16,0
32	14,1
33	12,5
34	12,5
35	12,4



Figure 3 - Graphic analysis stretch 16 - the colour bands identify the distance from the hypothetical centre of the ditch.

In addition to a numerical analysis, a graphic analysis of the size has also been carried out. The axis of the ditch was used as a basis for creating coloured buffers that identify the increasing distance from the centre of the ditch. The central strip is 5 m wide and the adjacent strips each add 5 m to the central strip. A graphical analysis of this kind makes it possible to understand, at a glance, the size of the stretch and, in front of the complete map, to have an immediate picture of the homogeneous sections and the navigability of the circuit.

The data on the counting of the vessels through the orthophotos were compared with those declared by the nautical circles present along the ditch circuit. The circles were analysed based on data provided by the State Property Office in the form of shapefiles and data relating to the 2018 concessions. This comparison between state property data and the census was necessary because, even to an occasional observer, it is evident that the situation along the ditches is in some points regulated more by practice than by the concessions: there are numerous boats moored outside the water surface under concession, which are therefore not present in the state property data. However, it is precisely these situations of irregularities that must be documented to reorganize the circuit.

The Fossi system for Livorno is of fundamental importance: not only for the historical memory, but because, as can be seen from the analysis of the clubs, they are a place of aggregation and circulation. Despite this importance for the city and its inhabitants, state of conservation and maintenance is not adequate for use.



Figure 4 - Graphic analysis of the entire circuit and identification of stretches.

The analysis described in this paper can be a first instrument of knowledge and deepening of the situation and the basis for a redesign and upgrading of the whole system. The section analysis in the different stretches of the Fossi system shows that the width is homogeneous in some areas, but uneven when considering the whole circuit. In particular, the Venezia Nuova has a very narrow section with numerous curves, especially in stretches 7 and 8, while the Fosso Reale in the southern part has more linear and wider sections. The stretch of Fosso surrounding the Fortezza Nuova has two different halves: one sized like the ones in Venezia Nuova, being its extension, while the other one is wide more than 50 m. Despite these differences, the whole route is uniformly occupied by the circles and their concessions. The concessions concern the state property water: each club has an assigned area and declares how many boats are moored there. As regards the census of the boats present along the circuit, as already described in the introduction to the method, the data provided by the circles have been cross-referenced with the data from the 2016 ortho-photo-based census. Since the concession was based on the size of the water surface and not on the number of berths, it was decided to verify the consistency between the two sources. The comparison shows that there is a greater number of boats present along the circuit than the authorized one.















ABACUS	CHARACTERISTICS	IDEOGRAMMATIC SCHEME
berth 1	berth dimension 2,5x7 m	
berth 2	berth dimension 3,0x8,5 m	
berth 3	berth dimension 3,5x10 m	
berth 4	berth dimension 4,0x11,5 m	
berth 5	berth dimension 4,5x13,0 m	
red	non-compliant situation	
yellow	to be evaluated	
green	compliant situation	
o	no berth	
1a	berth only by one side, lateral	
1b	berth only by one side, longitudinal	
2a	berth by both sides, only lateral	
2b	berth by both sides, only longitudinal	
c	berth by both sides, mixed	

Figure 5 - Abacus of navigability.

With a view to upgrading and redesigning the system, this analysis focused on defining how many vessels to be relocated. AdSP MTS has produced a technical-economic feasibility study on a new landing place for social boating in the Bellana area of the Port of Livorno. The new dock will cover the stretch of coast between the Morosini dock, the Scoglio della Regina and the Nazario Sauro marina. The new dock will respond to specific needs of the territory, including the need to create a new infrastructure for "minor" boating, which currently crowds the Fossi. The relocation of the boats is not only possible, therefore, but a special space is already provided.

Expected outcomes

In order to arrive at a scientific definition of the number of boats to be relocated, also compatible with the urban plans, the requirements of Annex A "Discipline" of the Masterplan "The network of Tuscan ports" have been taken into consideration. Regarding canals, it is specified that they should normally be sized according to the following criteria:

- at least 1.3 times the length of the largest berth accessed from the channel with lateral mooring devices (briccole, finger or cat-way, mini-finger)
- at least 1.7 times the length of the largest berth accessed from the channel with longitudinal mooring devices (mooring post with drapes or slopes or similar).

Segment 16		Average segment width: 44.8 m					
Berth (typology)	Berth dimension	No	St (1.3L)	St (1.7L)	St (1.3L)	St (1.7L)	

Figure 6 - Result analysis stretch 16.

To guide the correct design, the Discipline defines the size of the berths with reference to the maximum size of the moored boat. The dimensions considered relevant for the analysis are reported in Figure 6, as they include the boats present along the circuit. For each stretch the average section has been taken into consideration, the types of berths present, and the size of the boats moored have been identified, thus defining the Scenario 0 of the current state.

To determine Scenarios 1 and 2, the data related to the mean section has been crossed with the data related to the minimum project section prescribed by the masterplan. To do this, the minimum channel widths were calculated based on the moored vessel. When entering these data in a matrix, when the minimum design size is smaller than the average channel width, the box is green (situation compliant with the masterplan); when the minimum design size is larger than the average channel width, the box is red (situation non-compliant with the masterplan). When the two numbers are too similar, the box is yellow: this is because, being the average and not absolute section of the stretch, the compliance with the masterplan must be verified. The project sections have been calculated both by type of moored boat and by type of berth: this is because it is the type of berth that determines the coefficient to size the channel, to be multiplied by the length of the berth. As regards the calculation of the section for one-sided approaches, the Annex is clear and specifies the coefficients. From the width of the ditch has been subtracted the size of the gangway, since gangways are always internal along the ditches, floating or suspended, reducing the useful section. For double berths, the useful width of the section was the total width from which were subtracted the widths of the gangways and of the berth on the other side. In the case of mixed berths, the minimum project canal width was calculated considering the longitudinal berth coefficient (1.7) with a lateral berth on the other side.

Within the matrix are also identified with an "X" the boats present along the stretch of ditch and how they are moored. In this way it is immediately possible to verify the suitability of the state of affairs with the requirements: when the X is in a green box, the situation conforms to the Masterplan; when it is in a red box, the situation does not conform to the Masterplan and those boats must be relocated.

Scenario 1 provides for a 1.20 m wide quay or walkway that meets PIANC accessibility standards; Scenario 2 provides for a 0.80 m wide quay or walkway, considering a possible derogation from the 1.20 m standard given the historicity of the site. Scenario 3 differs in that it only considers boats located near the scalandrone. Scalandrone is a typical access to the Fossi, identified by a large masonry chute that allows you to pass from road level to water level. With a view to upgrading the system, these accesses should be restored and made safe. Therefore, boats now moored in front of scalandrone, preventing access to the water, were counted in order to arrange for their relocation. Figure 6 shows an extract from the comparative table, where section status and boats to be relocated are highlighted.

Conclusion

It is possible to sum up the method in a flux diagram, showed in figure 7. This method is replicable and usable in all similar situations. The use of QGIS tools has saved a lot of time and resources. Comparing the analyses with Annex A prescriptions also makes them suitable compared to planning tools. Developing different scenarios has shown that, despite several assumptions, the number of boats to be moved is still of note.

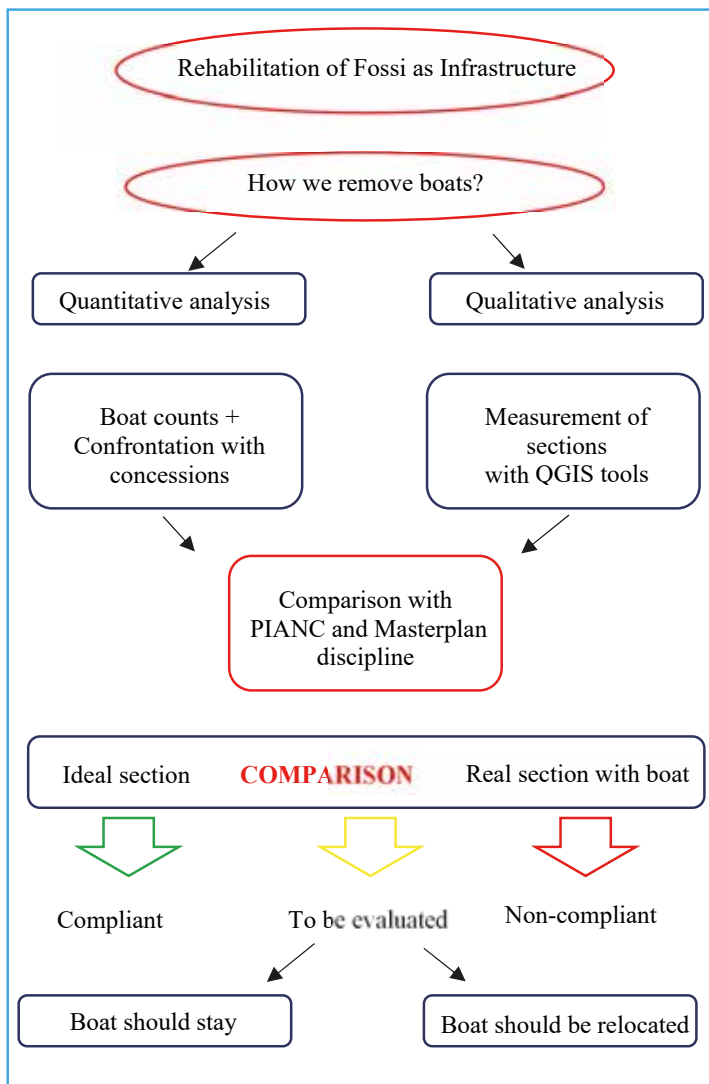

Figure 7 - Flux diagram.

In fact, the scenarios developed involve the overall displacement of a fair number of boats, about 45 % of the total. This means that now the situation is completely inconsistent with the regulations and the Fossi circuit is inadequate, in terms of size, to accommodate so many moored boats. Safety is not assessed since navigation safety plans are drawn up by other competent bodies (Harbour Master's Office).

However, possible solutions to such a situation have already been identified. As explained above, the new dock in the Bellana area would quickly solve the main problem of too large number of vessels. As far as nautical standards are concerned, however, the specific nature of the Fossi must be considered. Although it can be considered a port area for pleasure boating, the historicity of the site must necessarily be accounted for. As a cultural heritage site, it could be subject to derogations allowing it to be used without necessarily following the standards of the Masterplan. A redevelopment of the system, lightened by the cumbersome presence of many boats and transformed perhaps into a waterway and not just a parking lot, could return to Livorno and its citizens an important part of the city today undervalued.

References

- [1] AdSP MTS, Comune of Livorno (2017) – *Il sistema dei Fossi e delle Fortificazioni del porto franco di Livorno – Dossier Preliminare*, Historic Port Cities Network (HIPOC) for inscription on the World Heritage List UNESCO
- [2] AIPCN-PIANC World Association for Waterborne Transport Infrastructure – Italian Section (2002) -*Raccomandazioni tecniche per la progettazione dei porti turistici*
- [3] Port Authority of Livorno (2012) - *Piano regolatore portuale del porto di Livorno 2012. Relazione generale*
- [4] A. Mati (2018) - *Un approccio scenografico per la tutela del patrimonio storico-testimoniale del porto di Livorno*, Master’s degree thesis in “Architecture”, Firenze
- [5] Tuscany Region (2012) *Disciplina di piano*, Annex A – Elaborate 5, in *Masterplan “La rete dei porti toscani”*
- [6] M. Scamporrino, A. Mati, L.Montioni (2017) – *Photogrammetric survey at the urban scale of Livorno’s ditches*, Proceedings of the workshop AACCP “Reformation, regeneration and revitalization”

EVOLUTION OF THE COASTAL LANDSCAPE IN EASTERN VENETO: NEW DATA FROM PREVENTIVE ARCHAEOLOGY

Alessandro Pellegrini¹, Alessandro Asta²

¹Andrea Studio Associato, via Roma 121 - 31056 Roncade – TV (Italy), e-mail: studio@andrea.it

²MiBACT - Soprintendenza ABAP per l'area metropolitana di Venezia e le province di Belluno, Padova e Treviso, via Aquileia 7 – 35139 Padova (Italy), e-mail: alessandro.asta@beniculturali.it

Abstract – A preventive archeology study was recently conducted in the Caorle area (Province of Venice), in order to determine the possible archaeological risk connected to the realization of new defensive works from the erosion processes.

According to historical sources, Caorle could be identified as the ancient Portus Reatinum of Roman times, reached by land and water routes, located among trade networks, as also attested by archaeological evidences (terrestrial and underwater sites) identified in the area. However, some important Bronze age archeological sites and Byzantine evidences in the area confirm the strategic importance of the coastal strip.

Several new datasets have been now managed by computerized analysis. Some evidences, identified analyzing aerial photos and satellite images, are confirmed in ancient cartography found in the Venetian archives. The examination of stratigraphy preserved in many archaeological sites (belonging to prehistoric, roman, medieval and post-medieval times) could allow, in the next future, to estimate the growth of human population and land use, comparing the sea level dynamics in the northern Adriatic.

General dataset has been increased with the aim of protect archaeological heritage and, possibly, to realize new predictive models for archaeological research and for landscape management; underwater archaeology and remote sensing analysis finally gave back a clearer image of the historical evolution of the eastern Veneto coast.

Introduction

Il litorale di Caorle si estende complessivamente per circa 5 km, ed è costituito da spiagge a scarsa pendenza, interrotte da foci fluviali e bocche portuali. Pesantemente urbanizzato, il litorale è soggetto a considerevoli fenomeni di erosione, a fronte dei quali si è cercato di porre rimedio attraverso molteplici interventi di difesa.

Il presente studio è stato realizzato dallo Studio Associato Andrea nell'ambito del progetto di un nuovo sistema di difesa attiva della spiaggia di Caorle, in fase di realizzazione. Il progetto prevede il prelievo di sedimenti dalla spiaggia di Levante, destinati al ripascimento del tratto di Ponente, dove verranno realizzati nuovi apprestamenti destinati a contrastare l'erosione costiera, costituiti da quattro nuovi pennelli e da un geotubo sommerso, disposto parallelamente alla linea di spiaggia, fra le teste dei pennelli.

Lo studio ha preso in esame l'area dei litorali di Levante e di Ponente (fig. 1), il primo compreso fra la foce del fiume Livenza (ad ovest) e la chiesetta di Madonna dell'Angelo, e il secondo fra questa e il porto di Falconera (limite est dell'area di indagine).



Figura 1 - Inquadramento dell'area di studio (elaborato da Google Maps).

Figure 1 - Details of the study area (Google Maps).

Materials and methods

La definizione preliminare dei rischi connessi al progetto deriva da una duplice valutazione: da un lato è stato necessario inquadrare l'interesse archeologico del territorio e dall'altro misurare l'entità dell'impatto previsto dalle opere. La documentazione relativa è stata redatta seguendo prevalentemente le linee guida del Ministero per i Beni e le Attività Culturali e per il Turismo nonché alcuni esempi di buone pratiche proposte nella letteratura scientifica [10].

L'interesse archeologico dell'area di indagine è stato dettagliato attraverso diversi filoni di ricerca: censimento e mappatura dei siti archeologici presenti nell'area di indagine, analisi delle fonti storiche, studio dell'evoluzione geomorfologica del territorio. Il primo filone ha comportato la disamina dei dati editi e inediti disponibili; questi ultimi sono stati reperiti mediante ricerca condotta negli archivi della Soprintendenza e sono costituiti sia dai report scientifici degli scavi archeologici eseguiti sia dalle segnalazioni di ritrovamenti.

La ricerca storica si è concentrata soprattutto sulle rappresentazioni cartografiche del territorio fra il XVI e il XIX secolo¹ ed ha permesso di delineare l'evoluzione del litorale nei secoli. La ricostruzione geomorfologica si è potuta basare anche su queste fonti, oltre che su specifici studi condotti sul territorio. Molto utili sono risultati anche i dati derivanti dall'interpretazione di foto aeree (voli *Reven* 1978, 1983, 1983, 1990, disponibili presso il Geoportale della Regione Veneto) nonché di alcune immagini satellitari catturate da

¹ Parte della documentazione consultata, è disponibile nel sito web del Consorzio di Bonifica del Veneto Orientale (www.bonificavenetorientale.it/percorsi/atlante). Il Comune di Caorle dispone inoltre di una serie di riproduzioni di antiche carte provenienti dall'Archivio Storico di Venezia, fornite dall'arch. Paolo Francesco Gusso, che ha gentilmente voluto condividere tali documenti con gli scriventi.

Sentinel 2, della costellazione Copernicus². L'analisi territoriale tramite telerilevamento è stata potenziata attraverso l'utilizzo di un drone. Durante questa prima fase dei lavori si è scelto di sorvolare le aree di indagine durante i picchi sigiziali di bassa marea dei mesi invernali. Tutti i dati acquisiti sono stati raccolti all'interno di una piattaforma GIS mediante utilizzo del software open source QGIS.

Le aree interessate dalle opere di maggiore impatto, ovvero quelle destinate ai nuovi pennelli, sono state infine investigate tramite ricognizioni subacquee, in modo da verificare l'eventuale presenza di siti o reperti di interesse in affioramento dai fondali. Le ricognizioni preliminari sono state eseguite fra dicembre del 2018 e gennaio del 2019. Si è deciso di circoscrivere le aree di indagine entro una *buffer zone* di 15 m per lato dall'asse di posa di ciascuno dei nuovi pennelli.

Results

I dati archeologici raccolti provengono prevalentemente da fonti edite: dal volume "Caorle Archeologica" del 2007 [16], nonché da diversi contributi editi. I dati inediti sono stati raccolti mediante consultazione del sistema informativo RAPTOR (www.raptor.beniculturali.it) [18] e dall'archivio della Soprintendenza. Tutte le informazioni sono state registrate nel database di QGIS e successivamente filtrate attraverso interrogazioni mirate, che hanno permesso di restituire mappe tematiche utili all'interpretazione del contesto. Complessivamente sono stati registrati 26 siti archeologici, distribuiti nel territorio di interesse e nei settori periferici circostanti.

Le mappe tematiche, in cui i siti sono stati classificati per tipologia e cronologia (fig. 2) mostrano come nessun sito di età protostorica sia stato ad oggi individuato nel centro storico di Caorle o nella porzione dei litorali interessati dalle opere di progetto. In questo periodo furono privilegiati insediamenti collocati lontano dalla costa, in punti sopraelevati prossimi alle sponde dei corsi d'acqua, come il presunto approdo individuato in località S. Gaetano (sito n. 1) [1] [3]. Per l'epoca romana le sole testimonianze provenienti dalla città di Caorle e dalle spiagge antistanti consistono in ritrovamenti occasionali di reperti decontestualizzati e in giacitura secondaria. Resti di strutture ed insediamenti sono stati individuati solo in settori più periferici: ad ovest dell'area di intervento sono concentrati nella zona di Eraclea (siti 2, 3, 4, 5) e di Valle Altanea (siti 6 e 7). Verso est, resti di ville marittime e fattorie sono stati rinvenuti in località Brussa - siti 23 e 25 - [2], [6], [11], e Bibione - sito 10, Mutteron dei Frati [19]. Tracce di frequentazione di età romana, ma anche resti di strutture murarie sono emerse presso la foce del Nicosolo, in località Falconera, sito 26 [7]. Questi ultimi siti sembrano disporsi lungo l'antico corso del *Tiliaventum Maius*, asse fluviale di aggregazione degli insediamenti di età romana.

Le indagini condotte nel centro storico di Caorle hanno invece restituito evidenza di insediamenti di età prevalentemente medievale o moderna.

Nel mare antistante il tratto di costa che va da Eraclea a Bibione sono stati infine individuati molteplici giacimenti sommersi. La più parte di questi è riconducibile a relitti di imbarcazioni da guerra di età contemporanea, che non interferiscono direttamente con l'area di progetto. Il relitto della nave romana di "Caorle_1" [8], ubicato a circa 13 miglia dalla costa, può essere relazionato ad una direttrice di navigazione che contemplava scali commerciali nei

² <https://www.sentinel-hub.com/>.

principali porti e approdi della costa veneta e dell'alto Adriatico. Da rimarcare invece il rinvenimento presso la "tegnua di Falconera", a circa 4-5 km dal promontorio di madonna dell'Angelo (sito 19), di un'ancora a T rovesciata, classica morfologia riconducibile ad età bizantina [9].

Fra i giacimenti semi-sommersi si deve segnalare in particolare il sito n. 18, collocato fra il limite ovest della scogliera prospiciente l'abitato di Caorle ed il tratto più orientale della battigia di Ponente. Sono stati qui individuati resti di strutture costituiti da blocchi lapidei, palificazioni lignee, anfore e altinelle, già in passato interpretati come resti di un abitato ora sommerso per effetto dell'innalzamento del livello del mare.



Figura 2 - Mappa dei siti archeologici nel territorio compreso fra la foce del Piave e il Tagliamento, classificati per cronologia.

Figure 2 - Archaeological sites and their chronology, between Piave and Tagliamento rivers.

Lo studio della cartografia antica consente di ripercorrere l'evoluzione geomorfologica del settore costiero, così come è stata ben inquadrata nella letteratura scientifica dedicata [14] [15]. Nelle mappe di XVI e XVIII secolo la laguna di Caorle appare molto diversa rispetto all'attuale, estesa fino al settore retrostante l'abitato. Questo aveva carattere insulare, come testimoniano la carta di Angelo dal Cortivo del 1527 (Archivio di Stato di Venezia, sez. Savi ed Esecutori alle Acque, Disegni Livenza, dis. 1), ovvero la più antica rappresentazione della bassa pianura fra Livenza e Tagliamento. La laguna andò incontro nel tempo ad un progressivo interrimento e le aree poste ad oriente della stessa ad una inesorabile sommersione, evidente dalla carta del 1644 dei periti Alberti, Fabris e Scola (medesimo Archivio e sezione, Laguna, dis. 44), che peraltro testimonia l'avvenuta diversione del fiume Tagliamento (1642), mentre il Livenza fu deviato nel 1655.

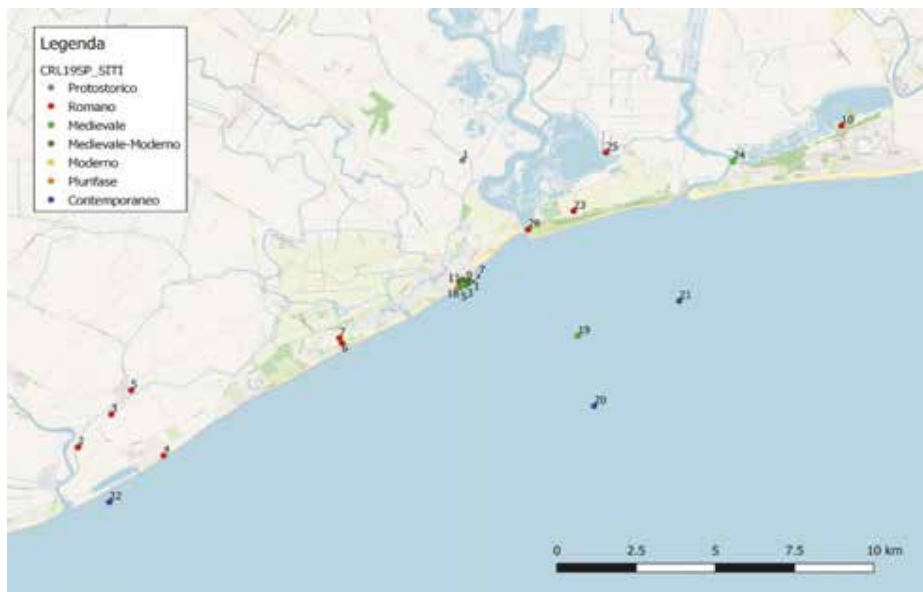

Figura 3 - Anomalie individuate sull'immagine Reven del 1990.

Figure 3 - "Archaeological" coastwise landmarks (Flight Reven 1990).

Per l'epoca più recente sono disponibili alcuni documenti che offrono la possibilità di ricostruire l'evoluzione del settore orientale, ovvero la spiaggia di Levante. La carta del 1801 di Anton Von Zach (Vienna Kriegsarchiv, tavola XV.14) mostra un'insenatura molto più profonda dell'attuale, a est del promontorio di Madonna dell'Angelo. La carta del 1808 del Catasto Napoleonico riporta inoltre la posizione del Porto di Palangon, ad ovest del Canale Nicesolo e lo sbocco a mare di un canale denominato "Canal Salso". Nella carta del 1811 di Trino Bottani [5] lo specchio acqueo compreso nell'insenatura è denominato "Porto di Caorle" ed è rappresentato il Canale di Palangone, visibile anche nella Carta di Cabotaggio del Mare Adriatico dell'I.R. IGM Milano, 1822-24 [22].

Risultati molto interessanti provengono dallo studio aerofotointerpretativo che ha permesso di individuare una serie di anomalie sommerse nel tratto di mare prospiciente il litorale di Ponente. Queste appaiono come tracce scure di forma poligonale, diverse fra loro per dimensioni e geometria, e risultano visibili in modo molto evidente nei voli Reven 1978 e 1990 (fig. 3), ma anche nelle immagini Google Earth attuali.

Una di queste, la n. 14, coincide proprio con il sito 18. Le immagini catturate con il drone, in condizioni di bassa marea, hanno permesso una migliore lettura dei contorni di queste strutture, nonostante la sospensione causata dal moto ondoso. Le verifiche subacquee si sono concentrate soprattutto in quest'area, perché è la zona più esposta al rischio di impatto con la costruzione di uno dei nuovi pennelli. Le ricognizioni hanno permesso di appurare che

questo tratto di spiaggia si trova ora in una situazione di ripascimento localizzato, e che le strutture descritte negli archivi sono probabilmente sepolte dalla sabbia.

Degna di nota risulta anche l'anomalia n. 1, che presenta una forma che si discosta dalle altre, con una traccia centrale sub-rettangolare, lunga circa 50 m e larga 30 m. Verso il vertice NO sembra presente un altro elemento quadrangolare connesso a quello centrale. Questa è posizionata circa 200 m ad ovest della Madonna dell'Angelo, che secondo alcune interpretazioni potrebbe coincidere con lo sbocco dell'antico *Reatinum* citato da Plinio il Vecchio. Altre due tracce sembrano degne di nota: visibili nel solo dato telerilevato del 1990, sono costituite da due linee arcuate (n. 16 e 17), con debole convessità rivolta verso nord-ovest, estese per 300 m ciascuna, con orientamento SO-NE, di fronte alla spiaggia di Levante, in prossimità di un'antica bocca portuale. Una di queste, in via del tutto ipotetica, potrebbe essere riconducibile ad un accumulo di detriti lungo il fianco di una barra rilevata dal fondale. Un'altra presenta una geometria interessante, con il limite ovest che termina con una forma angolare evidente.

Discussion

L'evoluzione della fascia costiera di Caorle, per le fasi storiche più antiche, può essere ricostruita sulla base di poche informazioni. Gli studi climatici e in particolare la sequenza storica delle oscillazioni del livello del mare proposta da Fairbridge [13] suggeriscono la possibile evoluzione del quadro ambientale dell'Alto Adriatico, ma per quanto riguarda il settore costiero di Caorle, non sono molti i dati archeologici che possono validare le ipotesi proposte. Nel centro storico e lungo i litorali di Ponente e di Levante non vi è traccia di insediamenti di età preistorica e l'importanza del sito in età romana sembra poggiare prevalentemente sulla testimonianza offerta da Plinio che ricorda il *Portus Reatinum*, la cui collocazione è ancora oggi questione dibattuta fra gli studiosi [20] [21].

Ma per l'epoca tardo-antica e medievale i dati archeologici si fanno più cospicui e consentono di discernere gli adattamenti delle scelte insediative all'evoluzione della situazione ambientale. Ciò che emerge, in particolare, è il progressivo deterioramento ambientale che si verifica dopo la caduta dell'Impero e che trova eco nelle descrizioni delle fonti storiografiche, in modo del tutto coerente con l'ipotesi di una imponente trasgressione marina nella curva eustatica proposta da Fairbridge. Proprio in conseguenza della trasgressione marina, ma anche delle necessità difensive che comportano la militarizzazione degli insediamenti in età bizantina, l'antico porto di Caorle e il suo abitato sarebbe stato spostato dalla linea di costa e rifondato come *castrum* [12].

Alcune informazioni interessanti provengono dagli scavi condotti all'interno dell'attuale abitato di Caorle [17]. Questi hanno restituito tracce di diversi successivi eventi alluvionali e di opere di sistemazione idraulica che testimoniano il delicato equilibrio idrogeologico dell'area in un arco di tempo compreso fra l'VIII e il XIV secolo. I dati di scavo mostrano che problemi di tipo idraulico continuarono a caratterizzare Caorle anche nelle epoche successive. Opere di sistemazione spondale e continui innalzamenti dei suoli risultano inquadrabili fra la fine dell'epoca medievale e l'inizio dell'età rinascimentale e sembrano testimoniare una nuova fase di instabilità, prevalentemente riconducibile alle acque interne (fiumi e laguna).

A partire dall'età moderna (XVI secolo) compaiono le prime rappresentazioni cartografiche, le quali, oltre a testimoniare le trasformazioni dell'assetto territoriale,

permettono di identificare elementi cospicui del paesaggio edificato, in parte riconoscibili anche oggi. Le foto aeree e le immagini acquisite con il drone hanno consentito di individuare alcune anomalie localizzate lungo il litorale di Ponente, interpretate per confronto con le mappe antiche. Nel 1691 (mappa di Iseppo Cuman, Paolo Rossi, Angelo Minorelli, Giò Antonio Cornello – medesimo Archivio e sezione citati sopra, Livenza, D11) l'abitato viene ritratto con una sorta di palizzata continua a protezione del lato rivolto verso il mare dall'azione erosiva delle acque, che probabilmente si è fatta più aggressiva come diretta conseguenza dell'azione di diversione delle foci del Tagliamento e del Livenza. Nella mappa di Caorle di anonimo del XVII secolo (fig. 4) compaiono una serie di strutture aggettanti verso mare, contraddistinte da una serie di numeri e lettere, che sembrano disegnate con la medesima caratterizzazione della palizzata di conterminazione della sponda. Se ne può forse dedurre che si tratti di opere realizzate tramite palificazioni lignee. Verso Ponente una serie di palificazioni probabilmente delimitava il Porto di S. Margherita con lo sbocco a mare del Livenza. Dubbia rimane la funzione degli altri manufatti, forse interpretabili come moli per l'ormeggio di imbarcazioni, se non come presidi di difesa dal mare. Un'altra mappa, del 1728 (fig. 5), fotografa una situazione simile. In quest'ultima, tuttavia, le strutture aggettanti verso mare appaiono differenti come rappresentazione grafica e sono etichettate solamente con indicazioni numeriche. La comparazione fra le due carte suggerisce che qualcosa, nell'arco di tempo che le separa, debba essere cambiato. Per quanto non suffragata allo stato attuale da dati storico-archivistici, si può azzardare l'ipotesi che le preesistenti strutture in materiale deperibile siano state sostituite verso la fine del XVII secolo, o gli inizi di quello successivo, con opere più durature, forse in materiale lapideo. Non è chiaro se tali presidi abbiano mantenuto o meno la funzione originaria. Rimane del tutto da verificare se almeno una parte delle anomalie individuate dal telerilevamento possa essere riferita agli elementi ritratti nella cartografia storica. Se così fosse, l'ipotesi sopra esposta potrebbe suggerire un termine *post quem* per l'inquadramento cronologico dei manufatti ed aiutare a comprendere la portata dei fenomeni erosivi innescati lungo la costa a fronte delle azioni intraprese per tentare di porvi rimedio.



Figura 4 - Dettaglio di una mappa del XVII secolo, (ASV, Miscellanea Mappe d. 100) con le strutture di difesa realizzate lungo l'abitato e ad est dello stesso.

Figure 4 - Defense structures built along the coast, nearby Caorle, as represented in a 17th cent. map (State Archive of Venice, Misc. Mappe d. 100).



Figura 5 - Dettaglio della mappa di Lorenzo Boschetti del 1728³, con i pennelli e opere di difesa realizzate lungo il tratto costiero dell'abitato.

Figure 5 - Defense structures built along the coast, nearby Caorle, as represented in the 1728 map realized by Lorenzo Boschetti (detail).

La lettura della cartografia storica e la sovrapposizione della Carta Geomorfologica della Provincia di Venezia [4] forniscono alcuni elementi utili anche per inquadrare il settore in cui sono state rilevate le anomalie 16 e 17. La posizione di queste lineazioni risulta prossima a quella di un'antica bocca portuale, forse da identificarsi con l'uscita a mare del canale Palangon, riportato nella cartografia d'età moderna (Fig. 6).

Conclusion

La ricerca condotta fino ad oggi, nell'occasione di uno studio finalizzato alla tutela archeologica preventiva del territorio, ha inaspettatamente portato all'acquisizione di alcuni dati potenzialmente utili per meglio comprenderne l'evoluzione.

La prospettiva offerta dal telerilevamento offre oggi la possibilità di leggere le residue tracce sepolte, o sommerse, del paesaggio antico, che non sempre sono direttamente riconoscibili dall'osservatore "terrestre". Questi dati, sovrapposti alle antiche

³ Immagine gentilmente fornita dall'arch. Pier Paolo Gusso, riproduzione di una mappa conservata presso l'Archivio di Stato di Venezia.

rappresentazioni cartografiche, hanno permesso di avanzare altre ipotesi sulle trasformazioni subite nei secoli dall'abitato di Caorle e dalla fascia costiera. Tali risultati, per quanto parziali e preliminari, spingono a ritenere che il metodo di studio intrapreso, basato su una ricerca multidisciplinare, possa risultare proficuo. Purtroppo, nel momento in cui questo contributo viene scritto, l'emergenza sanitaria legata alla diffusione del virus Covid-19 ha costretto a sospendere le ricerche. È auspicabile tuttavia che nuove campagne di rilevamento da drone, seguite da ricognizioni subacquee di verifica, possano essere a breve condotte, in modo da raffinare ed allargare la base dei dati disponibili.



Figura 6 - Particolare della mappa del Lombardo Veneto del 1833 (Istituto Geografico Militare dell'I.R. Stato Maggiore Generale Austriaco, Fg. 4G).

Figure 6 - The Caorle coast, as represented in the 1833 map of the Lombard-Venetian Reign (Military Geographical Institute - I.R. Austrian General Defense Staff, Fg. 4G).

References

- [1] Balista C., Bianchin Citton E. (1994) - *L'indagine archeologica e geosedimentologica in località Case Zucca di San Gaetano di Caorle*, Quaderni di Archeologia del Veneto, X, pp. 161-178.
- [2] Battiston A., Gobbo V. (1992) - *Da Bibione a Baseleghe. Contributi per un'indagine storica del territorio*, Latisana-San Michele al Tagliamento.
- [3] Bianchin Citton E. (2007) - *Il sito di San Gaetano di Caorle: un approdo adriatico della tarda età del bronzo*, in L. Fozzati, *Caorle archeologica, tra mare, fiume e terra*, Venezia, pp. 33-56.
- [4] Bondesan A, Meneghel M. (2004) - *Geomorfologia della Provincia di Venezia*, Padova.

- [5] Bottani T. (1811) – *Saggio di storia della città di Caorle*, Venezia.
- [6] Busana M.S. (2002) - *Architetture rurali nella Venetia romana*, Roma.
- [7] Capuis L., Leonardi G., Pesavento Mattioli S., Rosada G. (1994) - *Carta Archeologica del Veneto*, vol. IV, Modena.
- [8] Capulli M. (2007) - *Il relitto di Caorle I*, in L. Fozzati, *Caorle archeologica: tra mare, fiume e terra*, Venezia, pp. 125-129.
- [9] Capulli M. (2014) - *Ancore “bizantine” dal mare di Caorle*, NAVIS 5.
- [10] Capulli M., Traviglia A., Pellegrini P., Rizzotto R. (2014) - *Archaeological Impact Assessments (AIA) in underwater environments*, Skyllis 14– Supplement, pp. 86-99.
- [11] Croce Da Villa P. (2002) - *Ricerche di topografia archeologica nel Veneto orientale: mappa archeologica aggiornata e informatizzata del Veneto orientale*, Gruaro.
- [12] David Flores A. (2007) - *Caorle medievale e moderna: ricostruzione critica dell'impianto urbano*, in L. Fozzati, *Caorle archeologica, tra mare, fiume e terra*, Venezia, pp. 33-56.
- [13] Fairbridge, R.W. (1961) - *Eustatic Changes in Sea Level. Phisic and Chemistry of the Earth IV*, pp. 99-185.
- [14] Fontana A. (2004) - *Le lagune di Caorle e Bibione*, in A. Bondesan, M. Meneghel, *Note illustrative della carta geomorfologica della provincia di Venezia*, Padova, pp. 367-378.
- [15] Fontolan G. (2004) - *La fascia costiera*, in A. Bondesan, M. Meneghel, *Note illustrative della carta geomorfologica della provincia di Venezia*, Padova, pp. 378-416.
- [16] Fozzati L. (2007) - *Caorle archeologica, tra mare, fiume e terra*, Venezia.
- [17] Fozzati L., Gobbo V. (2007) - *Le indagini archeologiche nell'area urbana e nel territorio di Caorle*, in L. Fozzati, *Caorle archeologica, tra mare, fiume e terra*, Venezia, pp. 65-124.
- [18] Frassine M., Naponiello G. (2013) - *RAPTOR 1.0. Archeologia e Pubblica Amministrazione: un nuovo geodatabase per la tutela*, Archeologia e Calcolatori, Supplemento 4, pp. 88-95.
- [19] Gobbo V. (1992) - *Scavo della villa marittima (pars urbana) del Mutteron dei Frati*, in A. Battiston, V. Gobbo, *Da Bibione a Baseleghe. Contributi per un'indagine storica del territorio*, Latisana-San Michele al Tagliamento, pp. 67-97.
- [20] Passariello V. (2007) - *Lineamenti storici dell'area costiera altoadriatica. Dalla nascita di un habitat lagunare alla X Regio e Venetia Marittima*, In L. Fozzati, *Caorle archeologica tra mare, fiume e terra*, Venezia, pp. 27-32.
- [21] Rosada G. (1979) - *I fiumi e i porti nella Venetia Orientale: osservazioni intorno ad un famoso passo pliniano. Il Portus Lipientiae: I dati e i problemi*, Aquileia Nostra L, coll. 193.
- [22] Varani L., Zunica (1974) - *Documenti cartografici per l'interpretazione del regime litoraneo tra l'Isonzo e il Foglia*. Consiglio Nazionale delle Ricerche, Programma speciale per la conservazione del suolo, Rapp. Tecnico 1.

ALONG THE CAERETAN COAST AND FORWARD ON

Patrizia Tartara

CNR-IASI P.le Aldo Moro 7, 00185 Roma, tel. 06-4993.7505, e-mail: patrizia.tartara@cnr.it

Abstract – The territory along the coast north-west of Rome, still well preserved; in the Etruscan period was for the most under Caere control; it had the three important ports. The territory of Caere has been analyzed for a long time now, through an historical-topographic analytical study of the traces of archaeological remains. The research has been carried out by use of historical and recent aerial photographs and glass slides, last but not least the contribution of the monitoring aerial flights operated with the Carabinieri Helicopter Group of Pratica di Mare.

Introduction

The territory along the coast north-west of Rome is still well preserved; in the Etruscan period it was for the most under Caere control, which had three important ports: Punicum (Santa Marinella), Pyrgi (Santa Severa) and Graviscae (Porto Clementino). Later it had gone under Roman control and its rural district as well. The territory of Caere has been analyzed for a long time now, through an historical-topographic analytical study of the traces of archaeological remains, specially related to the wide necropolis that are a characteristic of this site, howsoever able to have a rather satisfactory view of the historical landscape, where possible. The research has been carried out by use of historical and recent aerial photographs and historical glass slides, last but not least the contribution of the monitoring aerial flights operated with the Carabinieri Helicopter Group of Pratica di Mare in collaboration with the General Headquarter of the Nucleo Tutela Patrimonio Culturale of the Carabinieri. During such flights has been possible to take a large amount of oblique images with Cultural Heritage remains, both on land and into the sea.

Material and methods

Primary need is to take a census of the cultural heritage evidences known but particularly unknown, of the area taken into interest. In relation with the history of the coastal territory, a detailed study of the territory of ancient *Caere* has been dedicated to the topographical definition and the correct geographical positioning of every archaeological traces relating to its extensive necropolis and ancient road-network. This study initially involved the two plateaux of Banditaccia and Monte Abbadone. Subsequently, it was extended in the direction of the coast, SSE and NNW as far as Pyrgi (today the Castle of Santa Severa); it is still in progress. The maps used were those best suited for geographical positioning (in particular, those for the Regione Lazio, 1:10 000 scale). Analysis of historical and recent aerial photographs from different archives, with additional monitoring flights over areas of risk help to obtain an historical perspective of the territory and the coast to help the

protection of cultural heritage remains and of the few spots (fragments) of historical landscape. The first aim of this case study is the reconstruction of this territory in the past, as it has been occupied and used by ancient inhabitants: from the city to the two ports of Pyrgi and Alsium, along the coast and of course the vast necropolis. At the beginning of the research have been collected all the photographs since 1929 till today and consequently have been given an interpretation to all the traces of archaeological evidences that later have been geographically positioned on the cartography.

The IGM 1930 aerial photographs (glass slides 13x18 preserved at the Istituto Geografico Militare of Florence, IGM) are the most interesting for this kind of research. They can allow us to have a picture of the territory very close to the ancient time. It has been well preserved till the introduction of mechanical ploughs (during 60ties) to cultivate fields. A mosaic had been created from more than 40 photograms (fig. 1). The restitution of the vast number of traces evident in those aerial images of 1930, which were positioned upon the map (fig. 2), allows a good global vision of the archaeological patrimony area and a (currently partial) reconstruction of the ancient landscape.

The necropolis, on the two sides of the large plain of the inhabited area of the ancient city, make evident the global aspect of the complex, which consisted of the urban area and very extensive monumental necropolis flanking (or rather surrounding) it. These burial areas extend along the major axes of communication as far as the coastline and ports, with nuclei of various sorts of tombs or large isolated tombs. The excellent definition of the images 1930 also allows the reading and restitution of even the accesses (dromoi) and sometimes the burial chambers of the individual tumulus, as well as the primary and secondary road-system, both related to the necropolis and to the network of the territory and the coast. The global result of the graphic reconstruction based upon objective data deriving from photographic interpretation and systematic positioning, presents a situation quite different from the image of the archaeological area that is today available to the visitor as representative of the ancient city. This last is substantially constituted by that portion of the monumental necropolis of Banditaccia, systematised and able to be visited, in front on the medieval village and the castle on the acropolis (which are possible to be visited as much as the interesting Museum) and the modern inhabited area, which is partially overlaps the urban area of the ancient Caere. The monumental archaeological area that people visit is in fact but a minute fraction (roughly 10 %) of the ancient burial zone, most of which is preserved and able to be measured. The necropolis are mainly those of Banditaccia, Monte Abbadone, Polledrara and those less known of Macchia della Signora, Monte Abbadoncino and il Sorbo, the vast burial area at the base of the acropolis, where systematic excavations and fortuitous discoveries have documented even the most ancient phases of the necropolis. Consequently, the visitor does perceive them as obvious parts of a single, enormous monumental complex that is exceptional for its extent and in terms of its structural evidence for ancient Italy, which only in a little part, it should be remembered, is for some years now been listed amongst UNESCO sites.

On an aerial photogrammetric photograph of 2001 (fig. 3) it is possible to observe the modern and often unplanned urbanization: in comparison with the mosaic of the territory in 1930, we can appreciate as a big portion of the historical patrimony and the landscape have been cancelled. Thus much of the evidence have been obliterated by urban development, and the density of constructions has destroyed any possibility of the "appreciation" of the surviving monuments. Even in this instance, a good knowledge and a detailed census of the archaeological patrimony would have permitted a more rational urban development.



Figure 1 - Mosaic: photographs IGM 1930. The ancient city, the necropolis and part of the territory as far as the sea.



Figure 2 - Restitution of the traces (in red color), by P. Tartara.

Along the coast, beginning from the area of Fiumicino and its surroundings towards north, we find the Roman city of Ostia antica, still very well preserved and built with very good materials; it is less valorized than what would be possible. In fact, it would be useful, for instance, to organize small buses for little groups of tourists to be brought from the



Figure 3 - Cerveteri and the layout of the territory, with the new centres of urbanization (Cerveteri, Cerenova / Campo di Mare, Ladispoli, Valcanneto), in 2001.

Fiumicino airport to visit it. There are many people in transit at the airport, waiting even several hours to continue their flight to the final destination.

At the end of the runways of Fiumicino airport (after the Macchine Idrovore di Maccarese), there is the WWF Oasis of Macchiagrande. Past the little town of Fregene, in the area of Maccarese, the ancient coastal dune it is no longer very appreciable: intensive cultivation of carrots like other types of vegetables have caused the leveling of the terrain, cancelling the historical sites of many roman farms and villas that where built on it. A roman coastal dune road was even present, known by ancient sources. The watch tower of Maccarese, close to the beach, and the old village of Maccarese with the ancient castle of San Giorgio are very characteristic to be valorized, even for the biological products of the several farms in that area.

Corresponding to the coast, just a bit in the inside of the land, there is the beautiful castle of Torrimpietra (Albertini-Carandini property). The name derives from the nearby tower located on a large boulder (Torre in Pietra), which later became Torre Pagliacetto, from the name of the farmer who worked a magic. The first mention of the property is in a bull of Pope Leo IX of 24 March 1053. It had several owners, then in 1620 it became the property of the Falconieri, to whom the current appearance is due. The building has a central body and two towers with Ghibelline battlements. It was restored in the 18th century. Of great value are the church and the great staircase on the main floor of the castle made by Ferdinando Fuga and the internal frescoes by Ghezzi.

North of the modern village of Passoscuro it is visible the watch tower of Palidoro. Just beyond, during a monitoring flight with the Carabinieri Helicopter Group of Pratica di Mare, it has been possible to take some oblique photograph of an ancient canalization perpendicular to the coast. Coming from the inside, it ends with a semicircular basin. A little artificial pool is connected to it; on the north side of this last one it is visible the trace of a particular building, probably seventeenth century. Just ahead, after the mouth of the river Statua, it is visible part of the large roman villa of Marina di San Nicola, close to the beach, still not completely excavated.

Here again, just a bit in the inside of the land, a fortified farmhouse is visible in its current XIV century structure, with subsequent additions; probably built on Roman remains. The central body is fortified by 4 corner towers with battlements. Located along the Via Aurelia, it was a stopping point for travelers.

Carrying on along the coast the well known castle of Palo faces the sea with the close houses of the ex Villaggio dei Pescatori, both surrounded by the green area of the Natural Oasis Bosco di Palo.



Figure 4 - A) The roman maritime villa of Grottacce; B) Torre Flavia.

After the town of Ladispoli, the ancient Torre Flavia was almost into the sea (fig. 4, B), bombed during the last Second World War and now protected by breakwater. Built on the second half of the XVI century (as one of the 61 watch towers system, due to the reorganization plan for the defense of the coast desired by the Papal States) on the remains of a roman maritime villa, its name is due to the cardinal Flavio Orsini, owner of the entire property until the town of Cerveteri. In 1674 the whole property was sold to the Marquise Ruspoli.

Close to it to the north, there is an interesting green area: the Monumento Naturale Palude di Torre Flavia, visible, as it was, also in some historical aerial photographs IGM 1930. It represents the last fragment of the marshes and swamps that were to extend also to the area now occupied by the town of Ladispoli.

Passed the historical military airport of Furbara, still in use, there in another green area: the Riserva Naturale di Macchiatonda.

Along the modern via Aurelia, on the south side, during a monitoring flight it had been possible to identify some traces of a villa (fig. 5); the traces seem to belong to residential structures (and baths?), probably Roman in date, that lie to the East of the colony of Pyrgi. Close to them, other traces of structures linked to the previous group, probably storehouses and a cistern.

Further on is visible the beautiful castle of Santa Severa facing the sea (fig. 6).

The castle and the small fortified village maintain the form of the roman colony of Pyrgi (since 264 a. C.). Into the sea are visible the remains of the structure in tufa blocks (fig. 6), related to the ancient channel-port. Some other structures are perceptible under the surface of the water (fig. 7).

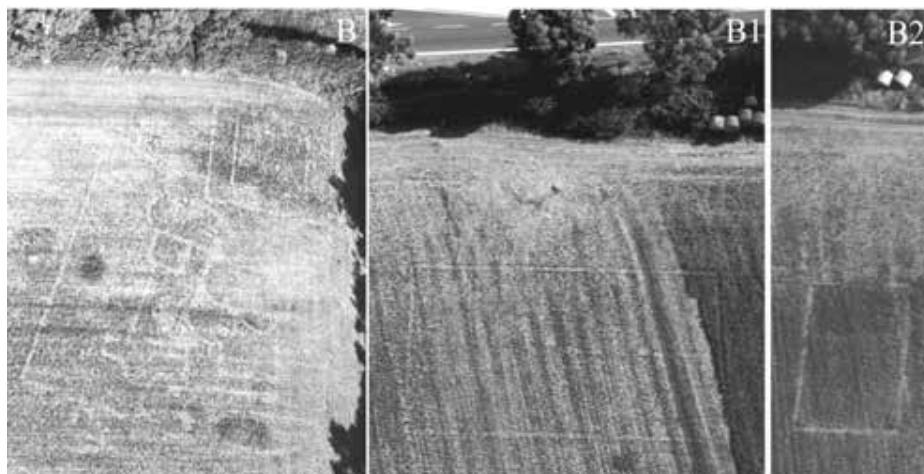

Figure 5 - B) Traces of residential structures (and baths?), probably Roman in date, that lie to the E of the colony of Pyrgi.

B1) Trace of a structure linked to the previous group.

B2) Trace of a structure (cistern?).



Figure 6 - The castle of Santa Severa and the structure in tufa block.



Figure 7 - Some other structures just under the surface of the sea, on the east corner of the castle.

Just a few dozens of metres to the south, lie the etruscan temples of Pyrgi in a wonderful preserved bay. An old Etruscan road joined the port to the ancient city of Caere; it was almost 9 metres wide.

Further on towards north, the remains of the roman villa of Grottafce are visible between the via Aurelia¹ and the sea, strictly surrounded by modern urbanization (fig.4 A) and in part covered by the sea, as shown by the semicircular structure and the other close structures of the maritime villa.

Along the coast, almost passed the town of Santa Marinella, shortly after the Yacht Club Castrum Novum, the remains of another roman maritime villa are visible into the sea, sometime just surfacing (fig. 8).

Even further ahead, at Punta della Vipera, other remains of a huge roman maritime villa with “peschiera” are visible underneath the surface of the sea; they are still well preserved, (fig. 9).

Last but not least, the remains of a roman maritime villa are visible in the north sector of the Civitavecchia port; close to them, some remains of tombs excavated into the rock. They have been almost cancelled by the urbanization related to the port and to the sea activities, (fig. 10), but actually preserved.

¹ To be added to the information about the territory is the presence of several “stations” or place where to change horses and rest for a while, like a sort of medieval “osteria” situated along the ancient route of the via Aurelia. Some remains of them are still visible in Casal Bruciato (Aranova) and at Statua.



Figure 8 - Remains of a roman maritime villa shortly after the Yacht Club Castrum Novum.



Figure 9 - Punta della Vipera, remains of a huge roman maritime villa with “peschiera”.



Figure 10 - Civitavecchia, northern area of the port (from Google Maps, 2020).

Conclusions

I want to clarify that I made the choice not to write the Discussion but to insert more images. I will say that it would be useful, for instance, to organize small buses for little groups of tourists to be brought from the Fiumicino airport to visit all those. As already said, there are many people in transit at the airport, waiting even several hours to continue their flight to the final destination. A strong work should be done to create a network to preserve and valorize them all, allowing people to appreciate the cultural heritage along this sector of the coast. But the primary need is knowledge.

References

- [1] AA.VV. (1968) - *La via Aurelia – da Roma a Forum Aureli*, QuadTopAnt, IV, De Luca, Roma.
- [2] Enei F. (2001) - *Progetto Ager Caeretanus – Il litorale di Alsium, Santa Marinella (RM)*, Regione Lazio-Comune di Ladispoli, Roma.
- [3] Tartara P. (1999) - *Torrimpietra (Forma Italiae)*, Olschki, Firenze.
- [4] Tartara P. (2003) - *Ortofotopiano storico IGM 1930 del territorio tra Cerveteri e la costa*, in Guaitoli M. 2003, *Lo Sguardo di Icaro. Le collezioni dell'Aerofototeca Nazionale per la conoscenza del territorio*, Campisano Editore, Roma, pp. 157-166.
- [5] Tartara P. (2008) - *Historical aerial photographs: the case of Caere*, in Proceedings of SPIE, Remote Sensing for Environmental Monitoring, GIS Applications, and Geology VIII, Cardiff (Wales-United Kingdom).
- [6] Tartara P. (2018) - *Territorio di Caere: viabilità e distribuzione delle necropoli attraverso la fotografia aerea*, in *Studia Caeretana* 1, pp. 123- 153

ARCHEOLOGIA SUBACQUEA IN LIGURIA: UN PROGETTO INTEGRATO PER LA TUTELA E LA VALORIZZAZIONE

Simon Luca Trigona

Soprintendenza Archeologia belle arti e paesaggio della Liguria, Via Balbi 10 - 16126 Genova
tel. 010/2718229; e-mail: simonluca.trigona@beniculturali.it

Abstract – The Ligurian area has always been identified as an important district for technical and scientific experimentation in the scuba diving activities, which today still represent a strategic sector for the regional economy and touristic development. Underwater archaeology also needs the convergence of many scientific, technological and management aspects. In this field many competences and technologies are called to cooperate: archaeologists, historians and botanists, geologists, architects and engineers, technical divers and contractors, public institutions and research foundations, all these different skills are required in order to create a connection between land and sea.

The Soprintendenza of Liguria has always given a particular attention to underwater archaeology and still today it pursues clear and specific aims: design, build, manage and increase competences and technologies that can be able to contribute to the regional and cultural development. The experience reached in Liguria by many years, led our activities of protection, research and valorization in order to develop a network of integrated archaeological sites and naval museums. On land this project provides two new museums in the cities of Albenga and Imperia that will be connected with a series of exhibitions and conferences.

The activities carried out by the museums are closely linked with the valorization and the research of the archaeological sites at sea. Several programs have been developed, implemented and tested with the achievement of making possible underwater tourism on archaeological sites (roman wreck of Albenga, Imperia, Lerici and Portofino). The idea of opening to the public these important wrecks, in addition to create new opportunity of territorial promotion, has ensured the effectiveness of the monitoring over archaeological sites, always vulnerable to external damages.

At the same time by improving protection and valorization on our underwater cultural heritage, the Soprintendenza of Liguria carried out new researches, such as the resumption of digging activities on the roman wreck of Albenga (2019), an important excavation campaign with saturation diving technique thanks to the cooperation of the Italian Marina Militare on the napoleonic armed tender of Capo Noli (2018) and the survey of two new sites in the area of Portofino, consisting of a wreck charged with gallic amphoras and a Genoese commercial ship of the XVIth century.

Introduzione

Nel panorama nazionale ed internazionale la Liguria costituisce da sempre un distretto di sperimentazione tecnica e scientifica nel campo della subacquea, attività che ancora oggi rappresenta un settore strategico di crescita imprenditoriale e turistica.

L'archeologia subacquea è un momento di sintesi di molteplici aspetti scientifici, tecnici e gestionali. Nel campo dei beni culturali sommersi sono chiamate infatti ad operare professionalità e tecnologie altamente specializzate: archeologi subacquei, restauratori e storici, sommozzatori e tecnici, ingegneri e architetti, informatici e imprenditori, enti locali e istituti di cultura, tutte figure funzionali alla creazione di percorsi culturali che permettano la connessione tra l'ambiente subacqueo e la terraferma.

Per questo la Soprintendenza della Liguria dedica particolare attenzione all'archeologia subacquea, perseguendo chiare e concrete finalità: progettare, costruire, gestire ed implementare luoghi, professionalità, tecnologie che possano contribuire allo sviluppo culturale e turistico del territorio. L'esperienza maturata in Liguria, una terra tradizionalmente legata al mondo della subacquea e dell'archeologia da campo, ha guidato le attività di tutela, ricerca e valorizzazione nello sviluppo del progetto di una rete integrata di siti e musei legati all'archeologia subacquea e alla storia navale.

Sulla terraferma le tappe di questo percorso sono la progettazione e l'allestimento dei nuovi musei di Albenga (SV), Imperia e S. Stefano al Mare (IM), Santa Margherita (GE) e Isola del Tino (SP), mentre a mare la valorizzazione dei contesti archeologici; per questo sono stati progettati, sviluppati e testati programmi di gestione per l'apertura alle visite delle navi romane di Albenga, dei relitti di Imperia, Lerici, Bogliasco e Portofino. Questo impegno, oltre alle finalità di promozione culturale e turistica, ha garantito alla Soprintendenza una più attenta e costante attività di tutela su siti ad alto rischio, oggetto negli anni di ripetute attività clandestine.

Contestualmente alle attività legate alla tutela e alla valorizzazione del patrimonio sommerso, la Soprintendenza ha necessariamente sviluppato un'intensa attività di monitoraggio e ricerca, che ha portato in questi ultimi anni alla ripresa delle attività di indagine archeologica sulla Nave Romana di Albenga (2015-2019), alla collaborazione con la Marina Militare per la realizzazione della campagna di scavo in saturazione sul sito della Lancia armata di Capo Noli (2018), al rilevamento e alla campionatura di una serie di nuovi relitti ai piedi della falesia di Portofino (2018-2019) e nell'altofondale della costa ligure di Levante (Relitti Isola del Tino 1-2 e S. Margherita 1).

Siti archeosub e musei della Liguria. L'attività di gestione, ricerca e promozione.

Ad oggi in Liguria sono oggetto di specifiche disposizioni di tutela tramite ordinanze dell'Autorità Marittima venti relitti di interesse archeologico; tra questi ben quindici sono oggetto di progetti di ricerca e valorizzazione.

Partendo dal Ponente Ligure i primi due siti che incontriamo sono il *S. Stefano 1* e l'*Imperia 1*, due relitti con anfore vinarie della tarda età repubblicana; il primo è stato scoperto nel 2006, mentre il secondo è frutto di una complessa indagine dei Carabinieri (Operazione Nemo) del 2013. Sebbene i due relitti giacciono a profondità significative (-58 m e -50 m), sono entrambi aperti alle immersioni tecniche ricreative gestite dai diving locali, tra cui il *Nautilus* di Davide Mottola, autore della scoperta del S. Stefano 1. Questa stretta collaborazione con i nuclei subacquei delle Forze dell'Ordine e con gli operatori locali ha consentito il monitoraggio costante dei siti, il loro rilevamento e l'acquisizione di significativi reperti poi confluiti, accanto alla nave a *dolia* del Golfo Dianese (fig. 1) e al

Leudo del Mercante di Varazze, nel nuovo Museo Navale di Imperia [1, 5 e 8]. Una sezione importante della nuova sala dedicata all'archeologia subacquea di questo museo (Sala Nino Lamboglia) prevede, inoltre, l'esposizione dei reperti frutto delle indagini dell'Operazione Nemo; si tratta di oggetti che provengono dai fondali dell'Imperiese che, grazie alle ricerche successive, è stato possibile ricondurre ai siti di provenienza, permettendoci non solo di arricchire le conoscenze scientifiche sui contesti archeologici, ma anche di comunicare alla cittadinanza il giusto significato e valore degli oggetti illecitamente trafugati.



Figura 1 - Museo Navale di Imperia. Sala Nino Lamboglia. Il relitto a *dolia* del Golfo Dianese.

Figure 1 - Naval Museum of Imperia. Nino Lamboglia's hall. The dolia's wreck of Diano Marina.

Passando alla provincia di Savona, troviamo il Museo Navale di Albenga e il costituendo Parco archeologico subacqueo di Albenga e dell'Isola Gallinaria, culla e sede tra gli anni '50 e '70 del secolo scorso dell'archeologia subacquea italiana, e oggi una delle mete liguri più frequentate dalla subacquea ricreativa nazionale e internazionale. In considerazione di questa forte valenza storico territoriale ad Albenga è stato sviluppato e testato un modello di fruizione, riprodotto poi anche in altri contesti, che, partendo dalla gestione e dalla tutela dei siti archeosub, si è progressivamente ampliato agli aspetti legati alla valorizzazione e alla ricerca.

Il progetto ha preso spunto dal successo riscosso dalle prime aperture straordinarie del relitto della Nave Romana di Albenga, una grande nave oneraria affondata all'inizio del I sec. a.C. con un carico stimabile intorno alle 10 000 anfore. All'inizio degli anni '50 del secolo scorso su questo relitto nasce e si sviluppa l'archeologia subacquea italiana con il Lamboglia; ciò che rende unico ed affascinante questo contesto, infatti, non sono solo le sue dimensioni eccezionali (si tratta ad oggi di uno dei più grandi relitti romani del Mediterraneo), ma anche e soprattutto il suo ruolo nella storia della disciplina; sulla sua superficie infatti possiamo leggere tutte le lacune e le tracce di decenni di immersioni e ricerche che, comunque, non hanno ancora svelato molti aspetti di questo importante sito archeologico [4].



Figura 2 - Il relitto della Nave Romana di Albenga. Mostra fotosub organizzata dalla Soprintendenza per promuovere l'apertura delle visite sui relitti nel 2014.

Figure 2 - The Roman wreck of Albenga. Underwater photographic exhibition organized by Soprintendenza to promote the openings of the wrecks.

A partire dal 2014 la Soprintendenza, in collaborazione con le autorità e le imprese locali del settore, ha intrapreso un articolato programma di valorizzazione e promozione, con l'apertura alle visite subacquee di tre relitti, la Nave Romana di Albenga, l'Albenga B e il relitto delle Ardesie. Inizialmente lo sviluppo di questo progetto non si è avvalso di alcun finanziamento pubblico, basandosi esclusivamente sul supporto degli operatori commerciali (diving) impegnati nelle attività di visita sui siti archeologici (fig. 2).

La gestione del parco archeo-sub si è svolta grazie ad un percorso autorizzativo concertato tra Soprintendenza e Capitaneria di Porto, che ha portato alla revisione della vecchia normativa, all'ampliamento significativo delle aree autorizzate alle immersioni e alla codifica di un protocollo informatico di gestione delle visite, banca dati indispensabile sia alle esigenze di tutela e controllo, che di gestione e coordinamento delle visite subacquee. Questo sistema di gestione, ormai collaudato, dall'estate del 2015 ad oggi (giugno 2020) ha permesso la registrazione di 28 230 immersioni, di cui 1514 sui relitti (relitti Albenga A, B e Ardesie). Tra gli aspetti più innovativi di questo sistema di regolamentazione è la creazione di un sito web dedicato: al sito accedono i diving autorizzati tramite iscrizione e password con scadenza annuale coincidente con la data di rinnovo delle autorizzazioni, prenotando punto di immersione, orario delle visite e indicando il nominativo delle guide e dei visitatori. La Soprintendenza e la Capitaneria vengono così informate giornalmente

delle attività svolte e hanno esclusivo accesso alla banca dati (*sezione authority*), sistema che consente l'archiviazione e la gestione delle informazioni relative alle presenze e alle statistiche complete dei siti di immersione e dei singoli operatori (fig. 2).

Grazie a questo programma di valorizzazione la Soprintendenza ha avuto la possibilità di intraprendere, grazie al supporto dei diving locali e dei Carabinieri, indagini conoscitive sui contesti archeologici, realizzando nel biennio 2016-2018 una campagna di ripulitura superficiale e il nuovo rilevamento della Nave Romana di Albenga, operazioni finalizzate a una più approfondita conoscenza del sito e a una puntuale azione di tutela. Nell'estate 2019 infine, grazie ad un finanziamento del nostro Ministero, sono finalmente riprese le indagini archeologiche, interrotte nel lontano 1985; lo scavo si è concentrato nella zona del pozzo della pompa di sentina e i risultati ottenuti hanno permesso di raccogliere nuove informazioni sulla nave e importanti reperti per il nuovo allestimento del Museo Navale di Albenga. Il cantiere archeologico, realizzato dai tecnici subacquei della Soprintendenza, in collaborazione con le Forze dell'Ordine, gli operatori dei diving autorizzati e archeologi O.T.S., è stato anch'esso aperto alle visite, riscuotendo un buon successo di pubblico soprattutto tra gli stranieri [8 e 10].



Figura 3 - Prospetto statistico delle immersioni svolte suddiviso per i diversi soggetti autorizzati.

Figure 3 - Dives diagram.

All'attività in mare si affianca sulla terraferma il nuovo progetto del Museo Navale di Albenga, rimasto finora sostanzialmente immutato rispetto all'originario e pionieristico allestimento del Lamboglia degli anni '60. Il nuovo percorso, seppur rispettoso dell'originaria impostazione che ne sostanzia l'intrinseco valore aggiunto, prevede che la visita prenda inizio dall'androne di ingresso, con una piccola sala introduttiva ad accesso libero ed uno spazio per le mostre temporanee, la prima delle quali sarà dedicata ai grandi lavori di dragaggio connessi alla costruzione della piattaforma *multipurpose* di Vado Ligure (SV) [11]. Al primo piano, oltre alla sala di ingresso-

reception, si colloca all'interno degli attuali spazi museali il blocco tematico dedicato al Parco archeo-sub di Albenga e dell'Isola Gallinaria; ad esso si aggiungono due nuovi ambienti dedicati alla storia dell'archeologia subacquea e alla tradizione ligure del Centro Sperimentale di Albenga, nucleo operativo afferente all'Istituto Internazionale di Studi Liguri che, a partire dagli anni '60 del secolo scorso, ha rappresentato la prima struttura operativa italiana dedicata alla ricerca archeologica subacquea [3].

La realizzazione del nuovo Museo Navale di Albenga e l'attività svolta sui siti del Parco Archeosub costituiscono un progetto di valorizzazione integrato e unitario, in quanto in futuro la gestione delle visite subacquee verrà trasferita al Museo Navale con specifica bigliettazione. Il progetto museale, anch'esso finanziato con fondi del Ministero, prevede infatti, oltre ai necessari allestimenti (teche, pannellistica, apparati multimediali, restauri e adeguamenti architettonico-impiantistici), specifici capitoli per la prosecuzione delle ricerche e la realizzazione di percorsi di visita subacquei (reali e virtuali) sul relitto della Nave Romana. L'attività di indagine scientifica in altre parole si integra e fonde con la progettazione, fornendo a quest'ultima i materiali necessari per la realizzazione del nuovo allestimento e mutuando dalla stessa i fondi per le attività di ricerca, restauro e documentazione.

Le esperienze acquisite in sede istituzionale e l'aumentata sensibilità maturata dagli operatori subacquei, anche grazie alla progressiva definizione e strutturazione del progetto di Albenga, ha consentito di sviluppare nuovi programmi di valorizzazione anche nel Levante ligure. La segnalazione del sito di Bogliasco (GE) operata della Polizia di Stato, ha aperto la strada anche in provincia di Genova all'apertura dei siti archeosub, mentre la recente scoperta ad opera di due sommozzatori locali, Gabriele Succi e Edoardo Sbaraini della società Rasta Divers, di un nuovo relitto ai piedi della falesia del Promontorio di Portofino (Portofino 3) ha creato l'opportunità per l'ampliamento del sistema integrato di tutela e valorizzazione all'Area Marina Protetta di Portofino, zona anch'essa ad altissima vocazione subacquea.

In questo specifico contesto a partire dal 2016 la Soprintendenza ha svolto una serie di interventi propedeutici volti alla verifica e al monitoraggio di due siti archeologici (Portofino 2 e 3), anche in questo caso realizzati grazie al supporto degli autori della scoperta. Si tratta di due relitti posti a breve distanza su un fondale di poco superiore ai 50 m di profondità, estremamente interessanti da un punto di vista archeologico: il primo è un relitto di età rinascimentale, curiosamente il primo scoperto nei dintorni del grande porto di Genova, caratterizzato dalla presenza delle ancore e delle bombarde in ferro forgiato (fig. 4), mentre il secondo presenta un raro esempio di imbarcazione commerciale romana di piccolo cabotaggio con un carico di anfore a fondo piatto della prima età imperiale.

La vicinanza reciproca e la posizione ai piedi della franata, nonostante la significativa profondità, rendono i due siti particolarmente adatti alla creazione di un percorso archeo-naturalistico per subacquei tecnici, il cui progetto, grazie al supporto dell'Area Marina Protetta, ha recentemente ottenuto uno specifico finanziamento all'interno del programma transfrontaliero Interreg Marittimo IT-FR (*Progetto Neptune*); anche in questo caso, parallelamente ai percorsi subacquei, si sta sviluppando in collaborazione con il Comune di S. Margherita Ligure il progetto di un nuovo Museo del Mare che raccolga i reperti provenienti dai relitti e promuova i percorsi e le potenzialità archeosub della zona.



Figura 4 - Il relitto rinascimentale Portofino 2. Rilievo fotogrammetrico.
Figure 4 - Plan of the Renaissance wreck Portofino 2.

Spostandosi ancora più a Levante troviamo il sito della nave lapidaria di Cala della Caletta di Lerici (SP) noto da tempo e oggetto negli anni di numerose campagne di indagine archeologica da parte della Soprintendenza [6]; su questo relitto nel settembre 2017 è stato firmato tra Ministero e Comune un accordo quadro per la fruizione e la promozione del sito sul modello sviluppato ad Albenga ma, per le caratteristiche del contesto, si è optato per un procedimento di gestione differente rispetto ai casi ingauni e imperiesi. In questo caso il Comune, tramite una procedura ad evidenza pubblica, ha individuato il soggetto a cui affidare la gestione delle attività di valorizzazione. Il procedimento concluso nel 2018 ha previsto un bando comunale rivolto agli operatori turistici-subacquei, invitati a presentare un progetto per la realizzazione di ormeggi, pannelli informativi e percorsi didattici anche per subacquei diversamente abili.

Uno degli aspetti più innovativi nel capo dell'archeologia sottomarina riguarda infine la ricerca e la tutela dei relitti in alto fondale: si tratta di un campo d'azione che prevede l'impegno di complesse tecnologie e competenze, in dotazione esclusiva alla Marina Militare e ad imprese specializzate nel settore. È stato pertanto necessario procedere ad accordi di collaborazione al fine di estendere le conoscenze archeologiche anche ai fondali più profondi. Questa attività si è sviluppata sui siti della *Lancia armata di Capo Noli* (Finale Ligure – SV) e su alcuni relitti di età romana del Levante ligure (*Relitto di S. Margherita, Relitto del Tino 1 e 2*).

Nell'estate 2018, grazie all'appoggio della nave Anteo della Marina Militare, è stata svolta una impegnativa campagna di scavo in saturazione sul sito della lancia armata di Capo Noli (-64 m), relitto di grande importanza storica riconducibile all'omonima battaglia navale tra la flotta anglo-napoletana e quella francese del 1795, mentre grazie al consolidato rapporto di collaborazione tra la Soprintendenza della Liguria e Azione Mare dell'ing. Gay, fondazione con grande esperienza nel campo della ricerca in alto fondale, è stato possibile procedere all'individuazione e alla documentazione di una serie di relitti di età romana. Tra le innumerevoli scoperte effettuate dalla Fondazione di Guido Gay infatti, due ricadono all'interno delle acque controllate dalla Capitaneria di Porto di La Spezia, il Tino 1 (*Daedalus* 12) a 400 m di profondità (carico di anfore Greco-Italiche del III sec. a.C.) e il Tino 2 (*Daedalus* 21) a -506 m (giacimento con anfore e ceramica di varie tipologie affondato tra II e I sec. a.C.), mentre un terzo è stato individuato al largo di Santa Margherita a circa 700 m di profondità (Relitto Santa Margherita 1 – *Daedalus* 26) [9].

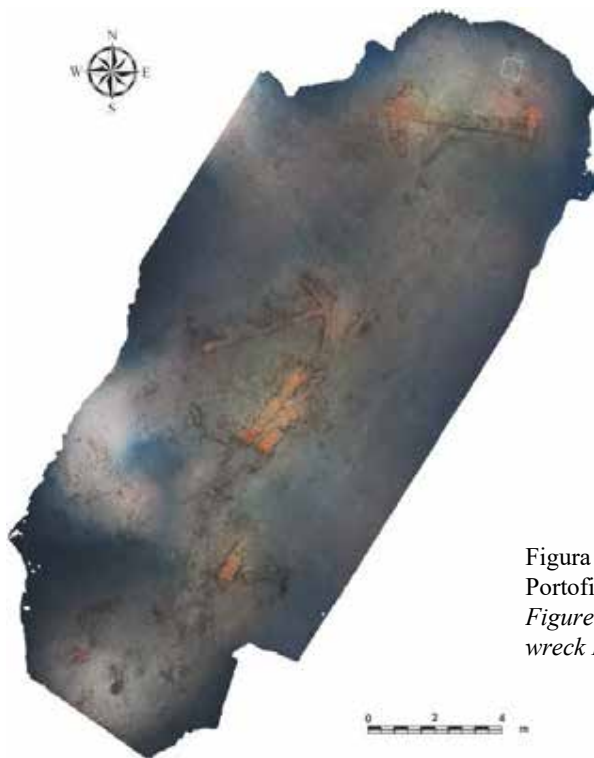
La storia della scoperta del relitto di Santa Margherita merita di essere ricordata in questa sede come esempio virtuoso che bene illustra le potenzialità di una corretta collaborazione tra operatori locali e istituzioni. Il 26 maggio del 2016, durante una battuta di pesca ai gamberoni su un fondale di circa 700 metri di profondità, il peschereccio *Impavido* di Santa Margherita salpava nelle reti 4 anfore romane. Con grande senso civico il comandante Gianni Paccagnella denunciava immediatamente il rinvenimento archeologico al locale Ufficio Circondariale Marittimo. Veniva quindi informata la competente Soprintendenza che, a seguito di una prima analisi dei reperti, disponeva la custodia delle anfore presso i laboratori dell'Area Marina Protetta di Portofino, al fine di provvedere alle necessarie e preliminari operazioni conservative. Considerando inoltre le difficoltà di affrontare la ricerca del relitto sulla scorta delle informazioni desunte dal percorso di pesca dell'*Impavido*, un tracciato GPS lungo una decina di miglia, la Soprintendenza contattava l'ing. Guido Gay, che nel settembre dello stesso anno riusciva a localizzare e a documentare il relitto (fig. 5).



Figure 5 - Particolare del carico del relitto S. Margherita 1.
Figure 5 - Picture of the S. Margherita 1 wreck.

Questi relitti in alto fondale sono quindi importanti contesti archeologici che rischiano seriamente di essere distrutti dall'attività di pesca a strascico, ma che oggi riusciamo a studiare e proteggere. Grazie alle puntuali ordinanze e ad uno specifico sistema di allarme satellitare messo a punto dalla Capitaneria di Porto di La Spezia è possibile identificare le unità navali che transitano in assetto da pesca sopra i fondali protetti e procedere con sanzioni amministrative in caso di violazione delle prescrizioni e penali in caso di danneggiamento. Contemporaneamente alle procedure di tutela, sono stati realizzati rilievi dettagliati che ci hanno permesso di stimare le dimensioni dei relitti, numerare, posizionare puntualmente all'interno del carico e procedere al recupero di una serie di reperti, necessari per comprendere le caratteristiche archeologiche e la storia della nave: una campionatura dettagliata delle differenti tipologie di anfore e delle varie forme della ceramica di bordo entrerà infine a far parte dei progetti di valorizzazione e dei nuovi allestimenti museali che la Soprintendenza sta sviluppando a Santa Margherita e sull'Isola del Tino (SP).

Conclusioni

Uno degli ambiti in cui opera l'archeologo subacqueo, strettamente legato come abbiamo visto a quello della ricerca, è la valorizzazione dei siti subacquei: in Liguria Albenga, città simbolo dell'archeologia subacquea a livello internazionale, è stato individuato come il luogo adatto per promuovere e sviluppare nuovi progetti in questo campo che, una volta testati, sono stati replicati in altri contesti della regione. Valorizzare significa soprattutto proteggere i siti archeologici, costantemente a rischio di depauperamento e distruzione non solo per le azioni di prelievo clandestino, ma anche per le attività di pesca non controllate e le opere a mare: la presenza costante del turismo subacqueo, così come le campagne di ricerca e sensibilizzazione pubblica, sono tra i pochi strumenti a nostra disposizione che, se gestiti correttamente, consentano una tutela concreta in ambito sottomarino.

Recentemente, infatti, ampio spazio all'interno dei programmi di finanziamento culturale della Comunità Europea è stato rivolto alla valorizzazione dei contesti archeologici sottomarini, nella consapevolezza che la fruizione dei siti subacquei attraverso sistemi di gestione integrati permetta da un lato una più incisiva azione di tutela da parte delle Soprintendenze, e dall'altro un significativo arricchimento dell'offerta turistico-culturale dei territori rivieraschi.

L'archeologia subacquea ligure, pertanto, non ha fatto altro che cercare di recepire e sviluppare sul territorio regionale quelle che la Convenzione Unesco di Parigi del 2001 sulla protezione del patrimonio culturale subacqueo, ratificata dall'Italia con la Legge n. 157 del 23/10/2009, i successivi dibattiti e le raccomandazioni espresse nel 2014 dall'Organo Consultivo tecnico-scientifico della stessa Convenzione, definiscono come *best practices*:

- ogni iniziativa che, in conformità con le regole dettate dalla Convenzione, permetta un accesso più ampio e responsabile del pubblico al patrimonio archeologico subacqueo;
- la fruizione non intrusiva dei beni culturali sottomarini da parte delle imprese locali e del turismo subacquei, nell'ottica anche di un miglioramento delle potenzialità di tutela e salvaguardia dei siti;
- lo sviluppo di progetti museali, pubblicazioni e prodotti multimediali.

Le istanze richiamate dalla Convenzione di Parigi, ribadite anche dalla Convenzione di Faro del Consiglio d'Europa del 2005, impongono alle Istituzioni un sempre maggior

sforzo, non sempre agevole in verità, verso la più ampia collaborazione di tutti i livelli sociali nell'ambito della definizione e della gestione del nostro patrimonio culturale. Questo approccio per essere sostenibile prevede da un lato la ricerca di forme di gestione inclusive, anche di natura manageriale, del patrimonio culturale subacqueo, dall'altro una tensione costante verso la diffusione delle conoscenze, delle pratiche e della cultura specifiche della tutela dei beni culturali. Nel settore dell'archeologia sottomarina la Liguria rappresenta sicuramente un territorio privilegiato per vocazione, tradizioni e collocazione geografica, e proprio per questo la Regione sta sviluppando il progetto di un Distretto Ligure della Subacquea, ma è ormai evidente come l'evoluzione della società e con essa delle nuove generazioni di subacquei guardino al mondo sommerso con una maggiore consapevolezza e rispetto, stimolando e favorendo la progettazione di nuovi sistemi di gestione sostenibile delle sue risorse.

Bibliografia

- [1] Benente F. *et alii* (2006) - Archaeological and instrumental analyses of pottery and wood from the 'Leudo' wreck of Varazze, Italy, *Medieval Ceramics*, 30, 61-72.
- [2] Camarda G., Scovazzi T. (2002) - *The Protection of the Underwater Cultural Heritage*, Milano.
- [3] Gandolfi D. (2017) - *Nino Lamboglia e il Centro Sperimentale di Archeologia Sottomarina: vecchie sintesi e nuove riflessioni*, in *Archeologia Subacquea. Storia, organizzazione, tecnica e ricerche* (Quaderni del SIMA, 3), Bordighera, pp. 11-37.
- [4] Gandolfi D., Trigona S.L. (2020) - *La nave romana di Albenga e il relitto a dolia del Golfo Dianese, capisaldi dell'archeologia subacquea mediterranea*, Thalassa. Meraviglie sommerse del Mediterraneo. Saggi, Milano, 42-49
- [5] Gandolfi D., Trigona S.L. c.s. (2016) - *Relitti e rotte commerciali nel Mar Ligure. Note per un aggiornamento*, in *Relitti e commercio nel Mediterraneo occidentale in epoca romana*, RAC Workshop – Roma, 17 marzo 2016
- [6] Martino G.P., Ocelli F. (2009) - *Rocchi di colonna ed altri materiali dal relitto di Lerici: considerazioni sulla circolazione del marmo in età romana*, in "Archeologia Marittima Mediterranea", 6, pp. 111-141.
- [7] Rey da Silva A. (2014) - *Designating a Unesco List of Best Practices of Access to underwater cultural heritage*, in *Actas del V Congreso Internacional de Arqueología Subacuática (IKUWA 5)*, Cartagena 2014, 71-85.
- [8] Trigona S.L. (2017) - *L'archeologia subacquea in Liguria. Recenti esperienze di ricerca e valorizzazione (2014-2016)*, in *Archeologia subacquea. Storia, organizzazione, tecnica e ricerche*, a cura di D. Gandolfi (Quaderni del SIMA, 3), Bordighera, pp. 271-280.
- [9] Trigona S.L. (2018) - *Archeologia subacquea in Liguria. L'attività dello STAS nel 2014-2015*, in *Archeologia in Liguria, Nuova Serie, Volume VI, 2014-2015*, Genova, pp. 182-202.
- [10] Trigona S.L., Gandolfi D., Capelli C., Arobba D., Caramiello R. c.s. (2019) - *La Nave Romana di Albenga (SV): il progetto di musealizzazione e le nuove indagini*, in *Atti del VI Convegno Nazionale di Archeologia Subacquea, Taormina 10-12 ottobre 2019*.
- [11] Trigona S., Ocelli F. (2016) - *Vado Bay Dredging through a long life harbour*, in *IKUWA 2016*, c.s.

SESSION

**COASTLINE GEOGRAPHY AND
COASTAL LANDSCAPES:
TERRITORIAL DYNAMICS AND
INTEGRATED PROTECTION**

Chairman: Gloria Pungetti
Department of Humanities and Social Sciences
University of Sassari

COASTLINE GEOGRAPHY AND COASTAL LANDSCAPES: TERRITORIAL DYNAMICS AND INTEGRATED PROTECTION

1. Introducing coastlines and landscapes

Coastal areas are strategically important in the Mediterranean as they perform natural, residential, recreational and commercial functions of particular relevance. Their protection and development must therefore take into account the physical, environmental and cultural characteristics of their territory and of the society that uses and manages them.

From a geographical point of view, coastlines are an evident border while approaching the land from the sea, whether by a conqueror in the past, or by a tourist at present. They mark a transitional zone between inland and outland, revealing the delicate equilibrium between environmental and human needs (Pungetti, 2012). However, often resource consumption along the coast prevails over the need to conserve biodiversity and marine ecosystems. In addition, natural dynamics on coasts, alongside human dynamics, are visible with bradyseism, coastal erosion, soil contamination and desertification.

From a landscape point of view, coastal landscape types vary from natural to seminatural, from recreational to urban. Coastal landscapes have been transformed during times to accommodate human needs, and only a few areas of the world present intact natural features, generally conserved by natural reserves, parks and marine protected areas. Merely coastal landscapes are nowadays seminatural, but a great deal of them have been urbanised and used for tourist, trading and residential purposes, causing several problems to their fragile ecosystems, which require more protection and recognition. Hence the complexity of these issues calls for the involvement of a variety of disciplines before tackling the problem properly (Pungetti, 2017).

This is the reason why it has been chosen to expand the Session of the VIII *International Symposium on Mediterranean Coastal Monitoring* to a diversity of topics that go from natural, socio-cultural, economic and legislative aspects of coasts, to their various forms of anthropisation and environmental restoration. Accordingly, a link between geography and landscape has been proposed, allowing the comparison between two disciplines so relevant for both land and sea.

This Session on *Coastline Geography and Coastal Landscapes* includes, therefore, works dedicated to a) the geography of coastal strips, and b) the dynamics of landscapes in the Mediterranean Basin. From the history and description of coastal landscapes, the session expands to its planning and integrated management of coastal areas, aiming to provide an interdisciplinary discussion on the above topics, and to suggest ideas for the conservation and development of coastlines and their landscapes.

2. Between nature and culture

Marine ecosystems are very fragile in the Mediterranean for the continuous human pressure they undergo. As shown in a research by Salaün, Pioch and Dauvin, artificial reefs are important tools to protect and manage these ecosystems. In fact, although they have been originally used for fishery purpose, they have recently been used also in ecological engineering to restore specific habitat functions in the Mediterranean France. For example,

they have been employed in eco-mooring, and as a substitute for natural reefs for diving activities. In addition, they have been used to sustain artisanal fisheries and to increase fish supply. As a result, the research has proved that artificial reef are also social tools for an integrated approach of an ecosystem-based management of coastal areas.

A sound integrated approach calls, in turn, to Integrated Coastal Zone Management (ICZM). This topic is also tackled by Tagarelli, Cantasano, Caloiero and Pellicone in a study linking Natura 2000 and cultural heritage sites on the Calabrian coast, where natural and cultural heritage are threatened by coastal erosion and human impact. This is evident in the seaboard landscape, meant as the long, thin area of a region that is next to the sea (Cambridge Dictionary, 1995). To overcome this risk, ICZM is urgently needed along these coasts to bridge nature and culture without compromising their heritage.

It is indeed crucial not only to protect, but also to restore natural and cultural heritage of coasts, especially in historic areas like the Mediterranean. To achieve this, strategic vision and design scenery are necessary in planning for sustainability, as accomplished by Pidalà research on the Nebrodi coasts of Sicily. In the division of the coast in three “macro dimensions”, i.e. beach, dunes and waterfront, comes forward the complexity of the coastline, where natural and human activities intertwine and develop, shaping land, shores and seas. Because of this complexity, mosaic landscapes are created, and when the impact on the marine environment is strong, criticality and negative effects occur. The answer is a new vision and a new scenario, which have foundations in the sustainability paradigm.

The complexity of mosaic landscapes emerges clearly in areas where territorial dynamic is high. One of these is the harbour environment. As Russo points out, past planning influence deeply the present and future coastal landscape and can alter its original feature creating a type of mosaic landscape difficult to manage. The port of Salerno on the Tyrrhenian coast is an example. Created in the Middle Ages, it deteriorated over time due to problems of cover-up, first, and wrong orientation later, with massive landfill phenomena leading to beach erosion. Therefore, a special regulatory plan has been developed, to carry out multiple defence interventions by sheltered cliffs that filled the coast, resulting in a total metamorphosis of the coastal strip. A coastal road has been also built for the new coastal settlements, together with the railway line that has connected the port to the city railway, halting ecological connectivity and dynamics.

Historical landscape developments are recorded in literature, mapping and images (Rackham, 1986; Pungetti, 1996), as well as through oral traditions and stories. A story telling experiment has been attempted by Ghersi in Capo Mele, on the beach of Laigueglia near Savona in Liguria. With a series of research actions from the study of biodiversity to the transformation of the beach, the research has explored material and immaterial resources regarding the place, and has moved to a series of micro-interventions for the public. These have outlined a new way to enjoy the beach, proposing different recreational and cultural activities, which make to reflect on the dynamics of coasts, with their sensitive and eco-sustainable management. Consequently, the initiative has conveyed to the beach the function of an active museum, a unique place for testing and monitoring new mechanisms for the use, protection and narration of landscape values, thus promoting socio-cultural development and biodiversity awareness.

The monitoring of cultural values is a topic which requires further development. An effort has been made by De Marchi, Lalli and Mancini with the online monitoring of environmental perception on the coast of Sicily. The Data Appeal Artificial Intelligence has been employed analysing reviews of texts and scores on Tripadvisor and Google from less than a

hundred public beaches in Sicily, in order to verify the level of cleanliness perceived by the users, and the main factors that determine a positive or negative judgment in the general perception. The findings have resulted in the monitoring of environmental conditions using available data posted online, which has then been processed and analysed by artificial intelligence.

The natural and cultural values of coasts and their landscapes should be not only studied, but also disseminated to young and adults through education and training. A large group of researchers (Altavilla et al.), has been involved in this task, carried forward environmental training for the Italian Coast Guard, an operational organisation for marine environmental protection. On top of standard teaching methods, i.e. face to face teaching, remote classes, use of case studies, simulations and exercises, the group has experimented hands-on training. This learning by doing has guaranteed the effectiveness of teaching, with students' involvement and experiential memory.

3. The other coast

Beyond the sea there is “the other coast”, not to be confused by the famous cartoon, but to be spotted in the fresh water of rivers and lakes. In the new link between town and water brought about by climate change, the rivershore shows new features. See level rise, thermal waves and torrential rains will be more common in the Mediterranean, affecting systems of coastal urban areas, for example the drainage system. To overcome this problem, Casu and Zaccagna have suggested to rethink at the role of urban spaces, considering a Sustainable Urban Drainage System for a more efficient management of the water cycle. This has led to a study on the estuary of the Tagus river in Lisbon, redesigning the relationship between water and city, with the purpose to make this urban area more resilient. Three scenarios have been proposed: one related to land use planning, two related to design and infrastructural choices.

Lakes present also interesting coastal environments. The microclimate of Lake Garda, for example, allows the growing of lemon houses along its coast, although located in north Italy. The so called “*limonaie*” are ancient terraced citrus gardens that not only shape the landscape of the lakeshores, but are repository of traditional culture and contemporary society. No longer crucial for the economic sector, they have moved toward natural and recreational functions. In this context, Cazzani and Barontini have offered an interpretation of Lake Garda *limonaie* as anthropogenic, labour intensive, multifunctional landscapes. With their steep calcareous slopes, local flora and fauna, bioclimatic adaptation and distinctive irrigation, this citrus cultivation play a central role in the symbiotic relationships between man and nature. Therefore, to preserve the fragility and peculiarity of the lake landscape, a holistic agro-eco-systemic perspective should be developed, taking into account the cultural heritage of *limonaie*.

Biodiversity and anthropisation are also the characteristics of three coastal lakes of Campi Flegrei near Naples. The deep link between nature and culture in this environment has been illustrated in a recent research by Giudici, Jannuzzi, Patrizio and Pisani Massamormile. Examining ancient literature, archaeological remains and previous studies, deep changes of this territory have emerged during the times. Geography, ecology geology, volcanology and hydrology are the basis for studies of this type, which anyway need to move forward to provide sound tools for integrated protection; this being a goal of this Symposium Session too. In this spirit, after analysing problems of careless, lack of planning and engagement tools, the need of restoring natural ecosystems and cultural landscapes has been highlighted by the research, integrating territorial needs such as nature and culture conservation, quality of life,

tourism and economy. Moreover, to succeed, stakeholders must be involved in actions for waterflow recovery, nature conservation and landscape restoration.

4. Scenario for development and planning

Scenarios are the foundations for coastal development and planning. Hydrological scenarios, for example, have been elaborated by Venudo, Rodani and Devescovi to explore potential design strategies for the Low Friulian Plain. Aiming at investigating the complex territorial transformation, the morphological history of a landscape unit has been described as a blend of biological deserts and wrecks of endangered landscapes. On the basis that hydrological risk represents an intrinsic and retroactive vulnerability of the area which could be adapted and mitigated, there is a need to recover, restore and monitor the water margin continuity through flooding strategies able to prevent future fluctuations. The foreseen scenario can therefore form the base for an overall masterplan for the Friulian “deserts”, aiming at its renaturalisation by means of preserving biodiversity and reducing fragmentation. A new landscape, finally, can take shape, reconstructing the environmental continuity and configuring the watershape within an ecological network for the Friulian deserts.

Development between infrastructures and innovation has always been a challenge in coastal areas. An attempt to create scenarios of the port area of Trieste, seen as an incubator of innovations, has been made by Bisiani and Savron with the objective to define a new landscape able to enhance activities that can provide quality of life and employment opportunities. In particular, a new landscape can be designed with modern technology, where infrastructure and storage space, both physical and digital, minimize the presence of man, configuring the logics of a new artificial living.

Scenarios for planning, moreover, are crucial in regional and local governance. The theoretical scenario implemented by the municipal plans of the Romagna coast has been recently analysed and discussed by Zullo, Fiorini, Marucci and Romano with the aim to highlight how their forecasts can change the future settlement structure, especially in highly urbanized coastal strip next to extremely fragile environments. New tools necessary for future developments are indicated in a technological platform linked with the environmental assessment procedures of plans for the optimised location of new settlements. Such optimisation would provide afterwards a balance between tourist economy and ecosystem preservation along the shores, with a strategically driven vision capable of directing territorial policies, environmental regeneration and sustainable transformation in the long run.

Extreme littoralisation, furthermore, is a common trend of contemporary seashores. The RE.CO.RD. project - Recycling strategies for the coastal sustainable waste management towards E&D innovation - of the EC Interreg Programme, aims to develop new strategies to arrest the environmental impact of economic activities linked to tourism in coastal areas. As outlined by Epifania and Pollice, networking and governance play key roles in the sustainability of coastline, and accordingly coastal developers have an active role for environmental qualification, and at the same time for the sustainable development of coastal tourism. Hence a multifunctional approach must be applied to coastal management of touristic areas.

It is not unusual to note indiscriminate soil and resources exploitation in favour of land use, threatening very fertile coastlines. The paradox, as Mazzeo points out, consists not of the lack of legislative or planning instruments for the regeneration of natural and agricultural sites, but of the poor results they produce, the uncontrolled urban expansion, and a management

completely indifferent to territorial risks. Despite this, possible intervention policies have been proposed in the Domitian coast in north Campania to redevelop this territory.

A different planning experience is described for the Tuscan coast by Saragosa and Chiti. With the objective of outlining the flows of energy in relation to the territorial structure, a cross scale survey methodology has been applied to analyse which settlement configurations can support quality of life. Future research development is however required to explore how the designed solutions support resilience. Hence it would be useful to evaluate the degree of adaptation and survival of species, and to find ways to manage through spatial configurations the ecological flows within the morphogenetic processes of settlements.

Territorial planning is often implemented at two levels: strategic with guidelines, and operational with plans. In harbour regions, the Strategic System Planning Document belongs to the first, and the Port Regulatory Plan to the second. A methodology to identify the port areas which influence the city has been proposed by Palano, Del Corona, Montioni, Pichi and Scamporrino, measuring the degree of such interaction through indicators. The study has formed the basis for the perimeter of the new port-city interaction areas within a Strategic System Planning Document for the North Tyrrhenian Sea.

5. Tools for monitoring and management

Before embracing any territorial management process, monitoring is essential to gather the necessary information on the state of the art of the territory involved. In turn, monitoring and management require tools to carry out the process. Among these are data bases, the foundation of any investigation. On this line, Esposito and Bosi have proposed a database to support sustainable coastal zone management, namely the LaCoast Atlas. This lays in the context of the LaCoast Project on land cover changes in coastal zones, i.e. a geo-referenced database that constitutes a tool for integrated spatial analysis of policies. The LaCoast Atlas database, built from Corine Land Cover database, Landsat images and desk teamwork, has investigated coastline changes, meant to provide indicators for European coastal zones management in order to support land use decision-making.

Mediterranean coasts, as well known, are under increasing human pressure, which has degraded ecosystems and landscapes. A particular challenge is the control of marine litter, which is causing increasing plastic pollution in our seas. Accordingly, a study aimed to analyse and to quantify the abundance, weight and compositions of marine litter has been carried out by a large research group (Corbau et al.) along two beaches of the Asinara Island in Sardinia. Analysing the marine litter, it has emerged that plastic fragments, lolly sticks and string are the most frequent type of debris.

The management of degraded material is doubtless a priority in the Mediterranean Basin. Lolli, for example, has clearly highlighted how our seabed is full of debris. Their removal from the seabed is imperative to maintain downflow conditions and land reclamation, to guarantee coastal protection, and to ensure navigability and port accessibility. Nevertheless, the fragile marine ecosystems are under threat by unsustainable dredging and management operations. Dredged material, in fact, should not be considered just waste, but in some cases it could be considered a resource. Further research and work, however, should be put forward to develop this resilient concept.

The above validates the importance of a vision for the future management of Mediterranean coastal settlements and landscapes. A synthesis among database, analysis,

tools and outlook has been attempted by Scamporrino in a study aimed to overcome a rigid zone planning, which has proved inadequate to manage Italian harbour transformation, in favour of a quali-quantitative approach supported by the View Management method consolidated in North Europe. Visual impact measuring instruments, accordingly, have been used to measure the visual and scenic impact known as “View Management”. This method can provide useful tools for the analysis, design and planning of urban and landscape transformations at visual and scenic level, especially in the mosaic landscapes of coasts with historical permanence. Their protection and valorisation are in fact significant to raise awareness on local identity, cultural heritage and image of coastal settlements and landscapes.

6. Conclusions

The Session Coastline Geography and Coastal Landscapes of the VIII International Symposium on Mediterranean Coastal Monitoring has demonstrated the key role that coastal areas play in the Mediterranean Basin, not only for their natural and recreational role, but also for their residential and economic purpose.

Mediterranean coastal landscapes, whether facing sea, river or lake, retain both natural and cultural values which are often threatened by human activities. It is hence necessary to protect these values, and to provide sound tools for ICZM, like up-to-date databases, monitoring processes, participatory design and planning.

Research, however, has outlined that, despite several legislative and planning measures are in place, there is still the need to implement a broad vision, interdisciplinary research, strategic planning and integrated management in order to protect, as well as to develop, Mediterranean coasts and their landscapes.

7. Acknowledgements

“Fondo di Ateneo per la ricerca 2019” is gratefully acknowledged.

8. References

- [1] Cambridge Dictionary, 1995. *Cambridge International Dictionary of English*. Cambridge University Press, Cambridge (print).
- [2] Pungetti, G., 1996. *Landscape in Sardinia: history, features, policies*. CUEC, Cagliari.
- [3] Pungetti, G., 2012. *Islands, culture and landscape*. Journal of Marine and Island Cultures, 1 (2): 51-54.
- [4] Pungetti, G. (ed.), 2017. *Island landscapes: an expression of European culture*. Routledge, London & New York.
- [5] Rackham, O., 1986. *The history of the countryside*. Dent, London.

Gloria Pungetti
DUMAS, University of Sassari
Darwin College, University of Cambridge
Email gpungetti@uniss.it

ENVIRONMENTAL TRAINING OF THE ITALIAN COAST GUARD BETWEEN TRADITION AND INNOVATION

S. Altavilla¹, A. Caligiore¹, J. Ceccarelli³, G. Corrente¹, F. Galeano², G. Pappacena²,
M. Pisconti², A. Petrillo⁴, F. Rottino⁵, P. Puri¹, G. Scatigna⁴, F. Simione⁴, T. Sinesi³,
G. Spaccavento⁵, C. Ubaldi¹

¹. Marine Environmental Department – Italian Coast Guard – Rome
(repartoambientalemarino@minambiente.it – 06 5722 5639);

². Headquarters of the Italian Coast Guard – Rome;

³. Training Centre on Environmental - Italian Coast Guard functions “B. Gregoretti” – Livorno;

⁴. Harbour Master – Portoferraio (LI);

⁵. Italian Naval Academy – Livorno.

Abstract – The geographical structure of our country requires constant and punctual environmental protection, which must be supported by operational components capable of expressing specific skills and a widespread and qualified territorial presence. In this sector, the laws that have followed over time have identified in the Coast Guard, an operational organization committed to safeguarding the marine environment, up to the constitution, with Law n. 179 of 31.7.2002, of the Marine Environmental Department, which represents an added value to the surveillance and protection system. Environmental police duties require qualified and specialized personnel. Therefore, it is necessary to integrate the "basic" preparation, with "specialist" training in compliance with the high standards of a Q.M.S. of training (UNI EN ISO 9001: 2015), which uses teaching methods advanced, classroom and scheduled lessons (face to face and remote), case studies, simulations and exercises, but also hands-on training. The latter methodology plays an important role since learning by doing (Learning by Doing), even more than theory, guarantees the effectiveness of learning, emotional involvement and the formation of experiential memory of learners.

Introduction

The Military Order Code includes the Coast Guard among the Corps¹ of Navy, giving it a strong specialist connotation and entrusting it with public functions that take place along the coasts and in the maritime spaces of national interest, for which it exercises competences relating to the matters of the Ministry of Infrastructure and Transport for which the law and other regulatory provisions provide for their direct attribution.

The Corps is also the recipient, even exclusively, of specific functions conferred by other Departments, including the Ministry of the Environment and the Protection of the Territory and the Sea and the Ministry of Agricultural, Food and Forestry Policies.

¹ Legislative Decree no. 15 March 2010, 66, "Code of Military Order" in art. 118, sanctions the division into Corps of the officers of the Navy. The Corps of origin identifies the functions and competences as indicated in the articles: 119 for the General Staff, 120 for the Marine Engineer, 122 for the Maritime Military Healthcare, 123 for the Maritime Military Commissariat and 132 for the Harbor Master's Offices.

The tasks assigned to the Corps are mainly attributable to five macro-sectors: the "*search and rescue of human life at sea and on the major Italian lakes*"; the "*command, the governance of the ports and the performance of the functions of the Maritime Authority*"; the "*protection of the safety of navigation, traffic and maritime transport*"; the "*protection of fish stocks and supervision of fishing activities and supply chain*"; the "*safeguarding and protection of the marine and marine-coastal environment*".

The latter is a priority objective to be pursued, both for the wealth of the national natural heritage, and for the significant social and economic interests involved in the use of the related resources.

In fact, the geographical structure of our Country and the huge extension of the coastline require constant and timely protection, which must be supported by operational components capable of expressing specific skills and a widespread and qualified territorial presence. In this sector, the law provisions issued over the years have identified the Coast Guard as an operational organization committed to the protection of the marine and coastal environment, up to the constitution, formalized with Law no. 179 of 31.7.2002, of the Marine Environmental Department, which represents an added value to the surveillance and protection system.

In relation to the aforementioned functions, the Corp performs the following tasks:

1. direction, pursuant to art. 23 of Law 979/1982, of the surveillance and control activities for the prevention of pollution of marine waters by hydrocarbons and other harmful substances, as well as for the detection of infringements of the relative standards;
2. surveillance, ascertainment and prosecution, pursuant to articles 135, 2nd paragraph, and 195, 5th paragraph, of legislative decree 152/2006, of the violations regarding illegal discharges, wherever they occur, when they are liable to damage or to pose risks to damage the marine and coastal environment, as well as infringements of legislation on wastes, including the repression of illicit trafficking and illegal waste disposal;
3. surveillance, pursuant to article 19 of law 394/1991, of marine protected areas (MPAs) and marine areas already recognized eligible for protection (future MPAs);
4. exercise of environmental police activities in accordance with current legislation [4].

Training, staff training and qualification

The multiple and articulated functions carried out by the Coast Guard in the environmental field presuppose that the staff is conversant with legal and high technical-professional issues and is capable to constantly cater for the necessary cultural and professional updating, in order to be able to better address the current tasks and future challenges of this complex sector.

The aim of this work is to illustrate, through the description of a *case study*, the teaching methods followed, as well as the specialized components used in the "*environmental training*" field, which arise from the guidelines of the Ministry of the environment and protection the territory and the sea, as well as the programming and coordination of the General Command of the Coast Guard.

Having regard to this it is wise to start from basic training, which is carried out for Officers in the Naval Academy and for non-commissioned officers and graduates in the schools

of the Navy of Taranto and La Maddalena. In these Institutes Officers are provided with the knowledge and skills on the plane of education and instruction, intended, respectively, as internalization of the cardinal principles of military status and as learning of the contents of general culture and of the skills necessary to carry out effectively and efficiently the tasks that the military will be called to perform, in each role of belonging, once sent to the future service venue.

In these early stages, the search for a balance between education and instruction constitutes an important challenge for military training, although the two poles of instruction and education, concerning respectively "*knowledge-that*" and "*knowledge-how to be*", must be enriched with "*knowledge-how*". The latter is considered a student's need to "*exercise and refine the ability to think and imagine, to learn, to use knowledge and to act ...*"².

Furthermore, in parallel with the aforementioned skills, it is essential to stimulate and increase the so-called N.T.S. (*Non-Technical Skills*³) required to assume and maintain military status.

Using these precepts, the Personnel Department ("*Schools and Training*" Office) of the General Command, during the basic training activities, organizes annually, in favour of the Corps Officers (Aspiring Ensigns) attending the Naval Academy, a training campaign, with the didactic objective of introducing the basic principles of marine ecology, environmental policing and remote sensing.

These campaigns entails the carrying out of practical exercises on the monitoring and control of marine ecosystems, also envisage the collaboration of the General Command Plans and Operations Department, with the use of specialist components and scientific instrumentation in the availability of the Corps (air-naval, underwater and Mobile Environmental Laboratories⁴) [5].

² Cfr Ingrassia D. "Knowledge, Skills and Abilities" A reflection from knowledge to well-being in "Leadership & Management" online magazine of 14.02.2017.

³ N.T.S. This term refers to "cognitive, behavioral and interpersonal skills that are not specific to the technical expertise of a profession but are equally important for the success of operating practices in maximum safety". The literature identifies seven that can be summarized as follows: situational awareness, decision-making, communication, teamwork, leadership, stress management and ability to cope with fatigue.

⁴ The Ministry of the Environment and of the Protection of the Territory and the Sea, as part of the program to strengthen the operational activities for environmental surveillance, has provided the Coast Guard with two "vehicles" set up as Mobile Environmental Laboratories (LAM) and equipped with equipment for performing "chemical, chemical-physical and microbiological analyzes" on fresh, marine and "waste" water samples.

The instrumentation supplied to the L.A.M., used by highly qualified and specialized military personnel of the Corps, allows sampling, both from land and sea, in the vicinity of discharges of urban and industrial waste water streams or of water from purification plants. With regard to analytical determinations, personnel capable of detecting the chemical-physical parameters *in situ* using the multi-parameter probe supplied and the loading of nutrients by using specific kits and ultraviolet/visible spectrophotometric techniques. As far as microbiological analyzes are concerned, it is possible to evaluate the presence of the *Escherichia coli* microorganism using the filter membrane method. The scientific component of the Corps is also equipped with the fixed Environmental Analysis Laboratory named after the "CF (CP) Natale DE GRAZIA", set up with cutting-edge instrumental equipment that will also allow the qualitative and quantitative determination of metals and hydrocarbons in aqueous matrices.

Considering the peculiarity of the sector as well as the variety/complexity of the activities carried out by the scientific staff of the Corps, it was decided to implement a quality management system compliant with the requirements of the UNI EN ISO 9001 standard. The Laboratory gained the related certification in 2013 (then renewed in 2016 and 2019, in compliance with the requirements of the new edition of the standard - 9001: 2015) for the following field of application: "planning and execution of sampling

The Official students, who are supported by highly qualified and specialized teachers and tutors, coming from the Naval Academy (Remote Sensing Laboratory) and from the Environmental Training Center "*M.A.V.M. B. Gregoretti*" of Livorno⁵, are involved in carrying out "*environmental monitoring*"⁶ activities [3] aimed at detecting potential environmental offences.

This activity, carried out on the territory in "*on job training*" mode, is also liable to be enhanced up to the real operational level, as it allows the Maritime Authority responsible for the territory to participate and to gain the subsequent results. Therefore, this training methodology may turn to a relevant benefit for the Public Administration in terms of efficiency and effectiveness of its action.

Confirming the importance that the Coast Guard attaches to the education, training and qualification of personnel, the aforementioned "*Schools and Training*" Office and Specialized Training Center have been certified according to the UNI ISO 9001: 2015 standard of the quality management.

The Corps has also decided to adopt a "*Training quality policy*", identifying processes and procedures that comply with sector regulations and are suitable for ensuring training based on standards goal-oriented towards continuous improvement.

The choice of using a quality management system responds, more generally, to an increased awareness of the role that training plays in the exercise of the peculiar and multiple skills of the Corp and to the desire to make this service as efficient as possible.

For logistical, operational and environmental availability, the aforementioned monitoring activity, implemented during a training period, is carried out on Elba island, an area that falls in the jurisdiction of the Coast Guard Office of Portoferraio (the venue of the Harbour Master Head of Maritime Compartment), hierarchically dependent by the main Regional Coast Guard Office, that is the Maritime Direction of Livorno (Leghorn).

The purpose of the training period is also to know and investigate, through activities carried out directly on the territory, any environmental criticalities detected, qualitatively and/or quantitatively, by the remote sensing systems supplied to the Coast Guard air vehicles.

At the same time, a Mobile Environmental Laboratory intervenes in the territory, for the swift execution of the analyzes of the main pollutants in the aqueous matrices, together with a nucleus of underwater operators of the Corps, provided with equipment for coring and collection of sediments and/or sea water, as well as portable video-recording tools and systems, such as the ROV (*Remotely Operated Vehicle*).

The results of the investigations carried out as part of the monitoring activity are also examined by the Environmental Police Operational Unit (N.O.P.A.) of the aforementioned Harbor Master's Office which, in the event of ascertaining criminal or

activities and water analysis for the surveillance and assessment of phenomena that may cause damage or deterioration in the marine and coastal environment".

⁵ Established since 15.9.2014, it was born from the need to harmonize and implement the interdisciplinary training of staff, relating to subjects such as the environment and fishing, together with the Institute's Corps services. Logistics and teaching aids have been designed to ensure efficient lessons and effective support for theoretical and practical training programs. Since 2019, the Center has achieved ISO 9001: 2015 certification in the "planning, execution and control of specialist training activities for staff inside and outside the Coast Guard".

⁶ For the definition of "environmental monitoring", please refer to the following link of the European Environment Agency (EEA): <https://www.eea.europa.eu/help/glossary/eea-glossary/monitoring>.

administrative offenses, draws up, with the Official students, the consequent judicial police acts. These activities, carried out on a yearly basis, allow to monitor the environmental situation of the territory, in order to verify whether the surveillance action (preventive and repressive) put in place by the Coast Guard is achieving the expected result, or to measure the improvement of the environmental conditions of the controlled areas.

The "*environmental monitoring*" activity, based on the continuous improvement of the environmental quality through the exercise of the supervisory action, concretely expresses what is represented in the "*Deming cycle*" or PDCA [2]⁷ "*Plan-Do-Check-Act*". In the case in question, in fact, we consider a "*Multi loop*" process in which the output of a cycle represents the input for the next cycle in a chain of repetitions over time capable of guaranteeing, after *n* cycles, the achievement of the set goal: "*Solved!*".



Figure 1 - *Deming Multi Cycles*.

Materials and methods

The applied methodology draws inspiration from Dewey's philosophical and pedagogical thought, who considers experience a "*continuous interaction between man and the environment in which man is not a passive spectator but interacts with his surroundings both in environmental and social terms*" [1].

In relation to the "*environmental monitoring*" activity for the training of Official students, the training campaigns carried out in the years 2018 and 2019 will be taken into consideration, in order to certify the use of the "*Learning By doing*" training methodology and application of Deming's "*Multi Loop*" Process Approach.

The aforementioned campaigns were launched as part of a report submitted in June 2018 by the operators of Goletta Verde, by means of which the presence of a high bacterial load was reported, in correspondence with the Mola Wetland, located in the Municipality of Capoliveri even if very close to Porto Azzurro harbour.

The didactic/operational intervention plan provided for a remote sensing activity aimed at mapping active coastal inputs.

The group of Official students of the 3rd class of the Naval Academy, to which the training activity of the year 2018 was addressed, was composed of 14 learners, divided into

⁷Cfr Any process can be seen as a cycle that has four moments: *plan* (design, plan), *do* (act, implement), *check* (check) and *act* (stabilize or correct and restart the intervention cycle), according to the hypothesis scheme- implementation-verification-new hypothesis inherent in natural laws. The novelty of Deming's operational reflection consists in having applied the idea of the cycle (and research) to organizations, which are thus considered to be individual bodies, subjects of study and intervention.

two groups of 7 people. This division was intended to stimulate and urge the exchange of views between the members of the group, as well as between them and the *tutors*, applying the "*Learning by doing*" method with those of "*Learning by thinking*" (learning through reflection) and *cooperative learning*⁸, in order to achieve optimal and lasting training results.

The first campaign took place from 30 July to 10 August 2018 and was planned with the contribution of the learners (**PLAN**), who actively participated in the organization of the remote sensing activity, carried out on 2 August 2018 (**DO**) with the use of a Coast Guard AW 139 helicopter, equipped with a FLIR tiltable system called "Star SAFIRE III", routinely used for the census of coastal immissions⁹.

Specifically, the wide field was used in reconnaissance activity while, in the areas subject to reporting, detailed surveys were carried out with more selective fields of view.

The second training campaign took place from 1st to 19th July 2019 and involved 18 Official students, split into 3 groups of 6 people. In this case, part of the monitoring activity resulted from the results of the remote sensing carried out the previous year, which had allowed to find, in the waters in front of the port of Porto Azzurro, a widespread thermal anomaly on which it initially investigated (**ACT** phase) the staff of the local Maritime Authority.

The operational activities were carried out with the same planning (**PLAN**) and execution (**DO**) methods of the previous year, while, as regards the (**CHECK**) phase, the staff of the local maritime office of Porto Azzurro, engaged in the preliminary environmental police control activities, he was joined by the Official students employed in the training campaign.

Results and their Discussion

The results of the FLIR remote sensing activity carried out in Mola in the Municipality of Capoliveri in response to the anomaly flagged-up by Goletta Verde are reported below¹⁰.



Figure 2 - Mola *Visible and Thermal Infra Red*.

⁸ Cooperative learning is based on the interaction within a group of students, with strong positive interdependence of purpose and work, who collaborate, precisely in order to achieve a common goal, through a deepening and learning work that will lead to the construction of new knowledge.

⁹ The FLIR system supplied to the Corps aircraft can only perform qualitative surveys (\pm hot and / or \pm emissive), i.e. it does not allow the "measurement" of the surface temperature of the framed areas but allows to obtain a representation of the scene framed based on the amount of energy "emitted" by the surfaces and/or objects present therein due to the temperature and/or the material of which they are made.

¹⁰ See previous paragraph.

From the analysis of the aforementioned images, namely from the Thermal Infrared band, it is apparent that there is an introduction of colder waters (darker shades) but it is not possible to identify the pipes that introduce the waste into the Mola ditch, since the same is covered by a copious vegetation (reeds) that hinders the aerial vision. Furthermore, as can be seen from the color *frame*, extracted from the aircraft's HDTV (High Definition TV Camera) subsystem, there are no anomalous colors of the waters near the mouth.

During the **CHECK** phase, the intervention of the L.A.M. for the execution of analyzes aimed at determining the presence of *"abnormal bacterial load in the water samples taken in the water body under examination"*. The results of the analyzes returned values of *Escherichia coli*, expressed as UFC/100 ml (Colony Forming Units in 100 ml of filtered sample), within the limits set by the reference standard (Table 3, Annex 5, Part Three of the Legislative Decree 152/2006). Therefore, it was considered that the excessive bacterial load, reported by the staff of Goletta Verde, was occasional as shown in the ARPAT Report *"The control of bathing water - Season 2018"*¹¹.

A widespread thermal anomaly was also detected within the port of Porto Azzurro. That has triggered the ensuing investigation activity by the personnel of the Coast Guard local maritime office (**ACT** phase).



Figure 3 - Porto Azzurro Thermal anomaly.

On 05 July 2019, the Petty Officer in charge of the aforementioned Office, perceiving a bad smell coming from the water mirror in front of the port quay, near the drainage pipes of rainwater and run-off of the same quay, verified the presence of some whitish and foul-smelling streaks of probable organic nature which attracted numerous fishes.

Therefore, a timely inspection of the grids and manholes located in the public road adjacent to the quay was carried out, without however detecting any anomaly.

Subsequently, given the impossibility of reconstructing the path of the whitish substance, the intervention of the Municipality's Technical Office was requested in order to inspect the pipeline backwards and try to find out the entry point of this substance.

¹¹ See Melley A. - Arpat Report - Bathing water control - Season 2018 *"During the whole season 2018 there have been various cases of pollution omission ... For the southern and insular coast of Livorno, the main critical factor is represented by more or less intense and often localized rainfall in a small portion of the territory which causes the spillage of untreated waste into the sea, due to the incomplete separation of the white (rainwater) and black (wastewater) sewage networks "*.

On July 9, in the presence of a team of the L.A.M., it was decided to carry out further checks in the area through a sampling carried out within the aforementioned pipeline, which was also actively attended by the Official students in training.



Figure 4 - *Sampling operations.*

On 11 July 2019, the intervention of a local self-purge company was requested, to carry out a video inspection of the white water pipes. This further check allowed to discover that "black" water was delivered to one of these pipes.

By using a tracer, it was possible to verify the spillage of black water into the white water due to the breakdown of the adjacent collection drain.

At the same time, the General Command's Plans and Operations Department produced the results of the analyzes carried out by the Environmental Analysis Laboratory on the sampling on 09 July. The so-called test report revealed what was found on 11 July, or "*... omitted ... it is reasonable to believe that there is infiltration of untreated waste inside the white water collection pipe*".

At the end of all the administrative and technical checks carried out, the watertight integrity of the wells was reinstated.



Figure 5 - *Infiltration point.*

Conclusions

Thanks to the various human and instrumental resources deployed by the Coast Guard, used following an "*integrated approach*" system, with these "*environmental monitoring*" activities, repeated cyclically, it was possible, first of all, to give a positive response to the criticality reported by Goletta Verde, and also to verify the possible commission of environmental offenses and to represent an effective deterrent tool for potential illegal conduct, in order to contribute to the improvement of the environmental conditions of the areas subject to verification.

In conclusion, through the description of a segment of the training activity of the staff of the Corps, it was intended to illustrate the methods of approach to the environmental inspection activity, based on the "*Deming Cycle*" or "*Plan-Do-Check-Act*" model, as well as the setting up of a learning mode based on learning by doing "*Learning by Doing*".

Bibliography

- [1] Crisafulli F. (2016) - *E.P. Educatore Professionale – Competenze, formazione e ricerca, strumenti e metodologie*, Maggioli, Santarcangelo di Romagna, 33.
- [2] Ishikawa K. (1988) - *Guida al controllo della qualità*, Franco Angeli, Milano.
- [3] Mangun W.R., Henning D.H. (1999) - *Managing the Environmental Crisis: Incorporating Competing Values in Natural Resource Administration Crisis*, 2^a ed., Duke University Press - Durham and London, 374.
- [4] Rovito C. (2016) - *La campagna di tutela ambientale della Guardia Costiera a tutela e difesa dell'ambiente marino e costiero* in magazine on line "Diritto all'Ambiente" www.dirittoambiente.net.
- [5] Rovito C., Pisconti M. (2016) - *Le Capitanerie di porto Guardia Costiera ed i L.A.M. – Laboratori Ambientali Mobili al servizio della tutela dell'ambiente marino*, in magazine on line "Diritto all'Ambiente" www.dirittoambiente.net.

NEW SCENARIOS FOR A DEVELOPMENT BETWEEN INFRASTRUCTURES AND INNOVATION

Thomas Bisiani¹, Matteo Savron²

¹Università degli Studi di Trieste, piazzale Europa 1 - 34127 Trieste (Italy),
e-mail: tbisiani@units.it, ²matteo.savron@studenti.units.it

Abstract – Both infrastructure and research, development and innovation, make communications and exchanges between distant places possible. As a consequence, geographic positions and administrative borders of countries are less and less significant compared to the polarity of the individual cities [23].

Europe tries to keep up with this global vision, European cities with the biggest growth rates are already “designing the revolution”. Stockholm, Copenhagen and Hamburg have developed strategic holistic plans where man and its needs are put at the forefront.

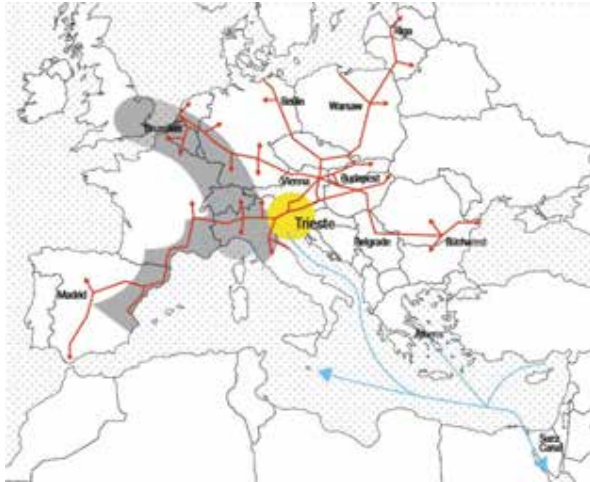

Figure 1 - Framing at the continental scale, pointing out the European macro systems Blue Banana and Arco Latino (Latin Arch) and the intermodal node of Trieste (in yellow), meeting point of the sea routes and the European corridors¹.

The growth trend also involves mid-sized cities. Some researches indicate that 77 % of the European cities with a population of more than 300 million have

¹ Source: Fraziano G., et al. (2015) – *Le regole del gioco. Scenari architettonici e infrastrutturali per l'aeroporto FVG*, EUT Edizioni Università di Trieste, Trieste, pp. 168-169.

Savron M. (2020) – *Trieste: nuovi scenari per uno sviluppo tra infrastruttura e innovazione*, dissertation Università degli Studi di Trieste, 2018-2019, rapporteur Bisiani T., co-rapporteur Meninno C., p. 65

1. SAIPEM – leader in the energy and infrastructure sector, has based in Trieste its center for submarine robotics, where OIE’s (Offset Installation Equipment) operative base had been established. It deals with the most recent and highest technology in the world to avoid environmental disasters from underwater oil spills.
2. Java Biocolloid – Indonesian company among the main manufacturers of red algae extracts for the food and pharmaceutical industries that has established in Trieste its European headquarter. This location favors distribution to Europe, the Middle East and the USA and offers development and innovation opportunities through the scientific organizations of the territory.
3. The Coltan – The so called “blue gold” is a superconductor with great ability to store electric charges. In March 2019 a 5 tons container has been confiscated in the port of Trieste for having violated the norms regarding radioactive materials. The Coltan needed to be processed and transformed in Trieste for the production and export of microchips [16].

This last example also confirms the existence of a model that rewards the infrastructural allocation and the commitment of innovation. It also brings out criticalities linked to dubious operations and the exploitation of rare lands and resources of the planet [3].

On these terms this research wants to underline regenerating scenarios of the port areas within Trieste seen as an incubator of innovations. The objective is to define a landscape of activities of great added value, able to affect the quality of life and employment opportunities, exploiting the new central port position [5] [6].



Figure 3 - Goods and passengers interchange nodes of the FVG, particularly the ports of Trieste and Monfalcone, the Fernetto Freight Village and the Trieste Airport (in yellow)³.

³ Source: Fraziano G., et al. (2015) – *Le regole del gioco. Scenari architettonici e infrastrutturali per l'aeroporto FVG*, EUT Edizioni Università d Trieste, Trieste, p. 213.

Designing with scenarios

From a methodological point of view this research presents itself as a natural continuation of the previous analysis [20] carried out within the supervision of the University of Trieste in order to define the guidelines for the realization of the intermodal hub of the Trieste Airport.

In both cases three development scenarios have been identified, one alternative to the other in order to evaluate advantages and disadvantages and define their suitability by comparing them to the contextual conditions. This approach enables to modulate for at least three degrees – one per scenario – some of the strategic aspects which, in the case of Trieste Airport, the level of infrastructure service and in the circumstance of this specific case study, the intended use of the identified development area.

This research, requires a further preliminary action, carried out through a series of interviews aimed at stakeholders and public figures that have allowed to identify a collection of four strategic development areas. The cross referencing of the data collected during the consultations has allowed the recognition of the area of the Industrial canal among others. Previously the lot was occupied by the former tobacco manufacturer, the former Giuliane Steelworks along with the currently disused logistic area located at the head of the canal and of the existing docs, where the main interests of the participants involved converged.

The consideration that such area possesses all the characteristics to reach high infrastructural development potentials within a fairly reduced time period, being already the interest of private industrial investments of innovative character, supports the choice made.



Figure 4 - Individuation of the four development areas (in yellow) and of the two macro systems of the infrastructural services (in cyan) and of innovation (in magenta), comprised of highly innovative activities⁴.

⁴ Source: Savron M. (2020) – *Trieste: nuovi scenari per uno sviluppo tra infrastruttura e innovazione*, dissertation Università degli Studi di Trieste, 2018-2019, rapporteur Bisiani T., co-rapporteur Meninno C., pp. 19, 23

The area occupies a strategic position since it is located at the center of the so called “logistics’ triangle”, defined by the centers of the new port, the new logistic platform of the dock eight (VIII), Trieste’s new Freight Village and of the former Aquila area, in the future a new multipurpose terminal recently acquired by a Hungarian developer.

In this regard, it is significant to underline that the position Trieste grants, on the one hand, reduced travel time of ships coming from the Suez Canal and a point of confluence for the eastern routes, and on the other, quick railway connections to the main European destinations.

The presence of a railway terminal within the currently discussed lot is of particular interest, it would offer added value to the development potentials, allowing a direct relation to the continental railway network.

Finally, a plan to insert the docks first and subsequently the surrounding industrial area within the margins of the FTZ (Foreign-trade zone) is already in place.

In response to the individualization of the area, three alternative scenarios have consequentially been recognized and are able to meet the expectations of the actors interested in the development of the area: the cold chain logistics center, the industrial hub and the data center.

The cold chain logistics center

The conversion of the intended use of the lot as a logistic area [18] includes the construction of two large warehouses designed for the storage of goods [14]. The parallel and perimetral position of the two buildings is dictated by the necessity to have wide maneuver areas for the loading and unloading activities of the goods. Moreover, an important multi-modal exchange is established. At the head of the area are located the docks equipped with the ship owner’s spaces, at the center with the trucks connecting it to the main arteries of the city and at the other end with the railway terminal.

As a whole, they guarantee a perfect reliability and operativity of the system, as well as a minimal impact on the maintenance of the ideal environmental conditions along the cold chain for the optimal conservation of the goods [23].

The industrial Hub

With its objective being aiming at the valorization of the development activities linked to the projects Sistema Argo and Freeway Trieste along with the exploitation of the presence on the territory of the Area Science Park, the third park in Italy for the birth and development of startups, the scenario promotes an Innovation Factory intended for the development of innovative products [10] [11] [12]. In order to allow the designer with original ideas to shift from concept to production, the Hub would provide in one location the technology, the competence in the field and the infrastructure; a working space, a research center, that offers expertise in the field of technology transfers, knowledge and strategic management of the R&D (research and development).

Data center

In the current geopolitical context [4], ports have established increasing importance as strategic factors of a state that is projected from the sea to the rest of the world. This scenario proposes the realization of a data center [15] in service to the logistics of transportation in support to the continuously growing infrastructural and technological development. In order to increasingly digitalize the ports activities and to maintain the terminal at a high level of international competitiveness the data center would include areas that are both inside and outside the administrative area of *the Autorità del Sistema Portuale del Mare Adriatico Orientale*. The data center represents the core of this strategy since it guarantees the 24/7 operations of all processes, communications and services in support of the logistic activities [9].

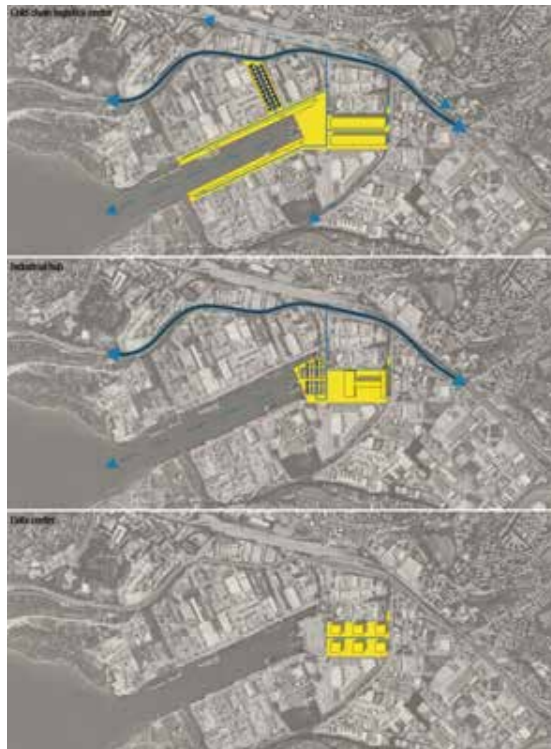

Figure 5 - The three alternative development scenarios individuated for the area of the industrial canal with the identification of the heavy infrastructures connected to the case study⁵.

⁵ Source: Savron M. (2020) – *Trieste: nuovi scenari per uno sviluppo tra infrastruttura e innovazione*, dissertation Università degli Studi di Trieste, 2018-2019, rapporteur Bisiani T., co-rapporteur Meninno C., pp. 67, 71, 75

The identification of an additional privileged scenario to this process has followed. It was obtained by developing an intermediate vision between two of the three scenarios previously mentioned, the industrial hub and the cold chain logistics center [1].

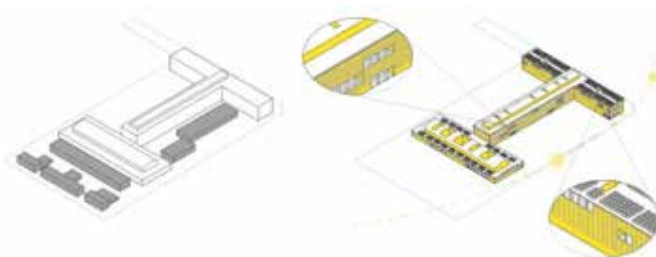

Figure 6 - Conceptual diagrams of the project development scenarios that verify the mixed scenario of the industrial hub and the cold chain logistics center. On the left, the planned demolitions (in grey) and on the right, the study of the facade enclosing and of the shading⁶.

The BIM project as a verification tool

The definition of the ideal scenario was followed by a verifying action through the development of an architectural project using BIM methodology [17]. This practice strengthens the choice to operate through scenarios as it allows to have, at the end of the process, a dynamic simulation. It can be reused in order to verify alternative hypothesis maximizing the modeling effort, that can efficiently be reused, allowing for easy comparisons and analysis.

Therefore, all the opportunities of simulations that offer BIM methodology need to be underlined. This technology offers different functions from those relating to physical performance (comfort levels, structural behavior, energy consumption, etc...), to those relating to expenses and execution costs, allowing in this respect for increasingly more objective and in depth analysis [13].



Figure 7 - Extracts of the section and floor plan of the project development with BIM simulation technology⁷.

⁶ Source: Savron M. (2020) – *Trieste: nuovi scenari per uno sviluppo tra infrastruttura e innovazione*, dissertation Università degli Studi di Trieste, 2018-2019, rapporteur Bisiani T., co-rapporteur Meninno C., p. 85

⁷ Source: Savron M. (2020) – *Trieste: nuovi scenari per uno sviluppo tra infrastruttura e innovazione*, dissertation Università degli Studi di Trieste, 2018-2019, rapporteur Bisiani T., co-rapporteur Meninno C., p. 114

A flexible methodology

The composite use of design by scenarios and BIM modeling [2] allows the management of the project, extended to the different scales. As a consequence, it is able to answer to different initial hypothesis and eventual contextual maintenance instead of having to deal with revisions that are normally necessary in order to modify and optimize the project as a subsequent validation of the preliminary proposals.



Figure 8 - General vision of the architectural intervention and of the arrangement of the external spaces and connections with the surrounding infrastructural systems⁸.

Conclusions

Simulation methods for both scenarios and project design, combined, demonstrate the ability to develop living solutions on various scales. This approach seems enriched by the possibility to apply interpolations of different solutions in both the scale of the scenario and of the design verification by exploiting the dynamism of the parametric modeling.

In this case however, it is not limited to these generic methodological conclusions.

It starts to outline specific emerging typological and architectural issues linked to the evolution of new landscapes of infrastructure and innovation. The analysis of the scenarios and of the activities compatible with the interests of the promoters of the development interventions, as a result, recognizes a series of activities and locations where mankind seems to progressively be emarginated or absent.

A new landscape made up of our machines, where infrastructure and storage spaces both physical and digital, minimize the presence of the human user, becoming occasional and an accessory.

⁸ Source: Savron M. (2020) – *Trieste: nuovi scenari per uno sviluppo tra infrastruttura e innovazione*, dissertation Università degli Studi di Trieste, 2018-2019, rapporteur Bisiani T., co-rapporteur Meninno C., p. 124

In any case it is about spaces that, even if uninhabited, are strategic, essential, in order to guarantee the functioning of the cities we live in.

These are spaces that define the very identity of the contemporary western culture, but we'll never be able to access them.

A system, in many cases that hasn't been thought out for us, but whose shape, maternity and function has been configured in order to answer to the logics of a new artificial living, where we are nothing but intrusions in an architecture that is completely indifferent to our presence and as of this moment seems to have left us behind.

Conclusions

- [1] A+t research group (2011) – *This is Hybrid. An analysis of mixed-use buildings by a+t*, a+t architecture publishers, Victoria-Gasteiz
- [2] Alesi U., et al. (edited by) (2014) – *Il BIM per i cost manager: requisiti del modello BIM. Linee guida RICS a livello globale*, RICS, London
- [3] Antonelli P., Tannir A. (edited by) (2019) – *Broken Nature. XXII Triennale di Milano*, La Triennale di Milano, Electa, Milano
- [4] Belanger P., Arroyo A. (2016) – *Ecologies of power*, The MIT Press, Cambridge
- [5] Burdett R., Sudjic D. (2011) – *Living in the endless city*, Phaidon Press, London
- [6] Burdett R., Rode P. (2018) – *Shaping city*, Phaidon Press, London
- [7] Cappochin G., et al. (edited by) (2014) – *Eco Districts. Strategies and techniques for urban regeneration in Europe*, 6th Barbara Cappochin International Architecture Biennial, Marsilio Editori, Venezia
- [8] Cappochin G., et al. (edited by) (2017) – *European Green Capitals. Esperienze di rigenerazione urbana sostenibile*, 7th Barbara Cappochin International Architecture Biennial, LetteraVentidue Edizioni, Siracusa
- [9] Carpo M. (2017) – *The second digital turn: design beyond intelligence*, MIT Press, Cambridge
- [10] Carta M. (2007) – *Creative city. Dynamics, innovation, actions*, Listlab, Trento
- [11] Carta M. (2016) – *Re_cyclical urbanism. Visioni, paradigmi e progetti per la metamorfosi cellulare*, Listlab, Trento
- [12] Carta M. (2017) – *Augmented city. A paradigm shift*, Listlab, Trento
- [13] Ciribini A., (2017) – *BIM e digitalizzazione dell'ambiente costruito*, Grafill, Palermo
- [14] Corbellini G. (2000) – *Grande e veloce. Strumenti compositivi nei contesti contemporanei*, Officina Edizioni, Roma
- [15] Cotton B., Oliver R. (1994) – *The Cyberspace Lexicon. An illustrated dictionary of terms from multimedia to virtual reality*, Phaidon Press, London
- [16] Crawford K., Joler V. (2018) – *Anatomy of an AI System: the Amazon Echo as an anatomical map of human labor, data and planetary resources*, AI Now Institute and Share Lab, New York
- [17] Eastman C., et al. (2011) – *BIM handbook. A guide for Building Information Modelling*, John Wiley & Sons Inc., Hoboken
- [18] Ferlenga A., Biraghi M., Albrecht B. (edited by) (2012) – *L'architettura del mondo. Infrastrutture, mobilità, nuovi paesaggi*, Editrice compositori, Bologna
- [19] Fraziano G., et al. (2014) – *Trieste, la misura del possibile*, Fresco Editore, Trieste

- [20] Fraziano G., et al. (2015) – *Le regole del gioco. Scenari architettonici e infrastrutturali per l'aeroporto FVG*, EUT Edizioni Università d Trieste, Trieste
- [21] Gandelsonas M. (1999) – *X-Urbanism: architecture and the American city*, Princeton Architectural Press, New York
- [22] Gramazio F., Kohler M., Willmann J. (edited by) (2014) – *The Robotic Touch. How robots change architecture*, Park Books, Zurich
- [23] Khanna P. (2016) – *Connectography. Mapping the future of global civilization*, Random House, New York
- [24] Khanna P. (2017) – *La rinascita delle città-Stato: come governare il mondo al tempo della devolution*, Fazi Editore, Roma (*Technocracy in America: Rise of the Info-State*)

NEW FEATURES OF THE RIVERSHORE: CLIMATE CHANGE AND NEW RELATIONS BETWEEN TOWN AND WATER

Alessandra Casu¹, Jlenia Zaccagna²

Università degli Studi di Sassari (Italy) - Dipartimento di Architettura, Design e Urbanistica
Pal. Pou Salit, p. Duomo 6, 07041 Alghero (SS)

¹phone: +39 0799720407, fax: +39 0799720420, e-mail: casual@uniss.it

²e-mail: jleniazacchi@gmail.com

Abstract – The study of Climate Change, applied to the Mediterranean urban scale, stresses several questions about how to adapt ‘old towns’ to the ‘new climate’. On another hand, Climate Change is also forecasted to affect the sea-level, which rise is menacing important urban areas (such as New York or the Flamish Delta region) and, even though at a lower level of risk, Mediterranean important urban heritages like the cities of Venice or Istanbul.

Although the difficulties of downscaling, climate scenarios show that Mediterranean areas will be affected on the one hand by thermal waves and, on another, by torrential patterns of rain, concentrating the total amount in a short time, that can cause difficulties in urban life, especially in coastal areas, mainly due to the draining systems. This asks for Sustainable Urban Drainage Systems and for a more efficient management of the water cycle, also rethinking the role of urban spaces. Portugal is considered Mediterranean, at least under the climate point of view, despite its coasts are almost Atlantic and, consequently, more exposed to the sea-level rise.

Lisbon is not exactly along a sea shoreline, but on the estuary of Tagus river, which would be probably affected by Climate Change effects because of run-off and, mainly, due to the forecasted rising sea-level. Rethinking and redesigning its relationship with water, trying to make this urban area more resilient, becomes crucial: it asks to study run-off and sea-level rise forecasted for 2100 and for intermediate steps, and to adapt the urban life and its spaces to the occurring scenarios. This work deals with the *Frente Ribeirinha* in South-West Lisbon, setting the objectives for its adaptation to flooding risks: ‘from above’ (rainfalls and consequent run-off) and ‘from below’ (sea-level rise), proposing a set of actions which can be combined according to different strategies.

The developed strategy proposals illustrate three different scenarios of how the whole area could be adapted, depending on the choices related to heritage protection, traffic management, run-off calming. These scenarios propose to transform the South-Western Lisbon waterfront working differently: one more with nature-based solutions, and the other two changing more radically the coast line, designing islands or bays (one could be consequent to the other) that establish priorities, ‘securing’ some urban nodal areas and ‘sacrificing’ some others. The first scenario is more related to planning choices regarding land-use, while the others are more related to design and infrastructural choices.

Introduction

Climate change is not only a global phenomenon, but it also has local effects, cause of catastrophic and extreme events, resulting in numerous negative consequences within urban areas. Extreme events, becoming more and more frequent nowadays, are a significant issue for the protection, security, adaptation and defense of towns and of human kind: thus, we are required more information given by scientific research, about future forecasts, regarding temperatures and precipitations, possible worst-case scenarios, should these changes accelerate due to climate mutations.

Scientific research establishes a framework of alteration in ecosystems and the increase of extreme weather phenomena, with effects especially in urban areas [2], and with economic, social and environmental contexts suffering dramatic consequences, generated by the increase of global warming [3].

The areas that undergo multiple transformations —such as the urban ones— risk to be the most critical of all, as the different natural matrices can no longer withstand this kind of stress. In order to avoid serious consequences, in addition to face the consequences of global warming [6], new adaptation strategies are becoming increasingly urgent [10]. A response to climate change can also be the conclusion of environmental, economic and social sustainability policies, able to set mitigation and adaptation targets for towns.

Urban areas then need to cope with a different approach, specifically regarding adaptation, strategies and interventions, which purpose is to provide safety and environmental comfort, making cities as protective and resilient as possible to weather events. One important problems is waterproofing the soil, which leads to some of the major and determining impacts, such as the change related to the outflow of water, the urban heat islands, the instability of the ground and the absence of environmental comfort [8].

In the Mediterranean climatic area, an extreme study case is represented by the territory in which the city of Lisbon is located, interposed between two large water bodies: the Atlantic Ocean to the west and the Tejo river estuary to the south and east. Because of these two large water bodies and the whole impact of the effects of climate change [5], Lisbon *Frente Ribeirinha* is classified in many studies as a vulnerable area, and it becomes necessary to develop a model of adaptation to the changing relationship between the city and the surrounding waters.

Environmental problems caused by climate change are anticipated, such as flooding caused by tidal changes, the increase in urban runoff, the mass of storms and heat waves, which will negatively affect the *Frente Ribeirinha*, by exposing the whole area at high risk. The whole area at risk interacts with the watercourse of the Tejo River: within the city there are several tributaries that can increase vulnerability in well-defined areas and are subject to floods, in case of water bombs. It is expected that the groundwater will increase, exposing plenty of buildings and roads at risk of destabilization, and soils to erosion.

The goal is to succeed in making this area more resilient to the effects of climate change, on the one hand to the rise of the average sea level and, on the other hand, to extreme weather events.

Flood management practices have to overcome sectoral paradigms to respond to climate change, through multidisciplinary and interdisciplinary approaches.

Materials and Methods

Regarding future scenarios the traditional, sectorial approach is quite misleading, because “estimated projections are indicative rather than definite, yet they are reliable” [4]. Urban planning should consider estimated projections as a deterrent to change, and the design of urban spaces should be crucial to adapt whole settlements to the expected changes. Some spaces are actually among the most vulnerable, especially to floods and, for these reasons, we propose three design scenarios, working with the uncertainty of future forecasts related to climate change, and paying attention to the transformation of coastal areas.

The model proposed within this article takes into consideration the research-by-design approach, as described by Nijhuis et al., [9]. Research by design allows to interpret the urban landscape as an interdisciplinary and multiscale research object, to acquire theoretical knowledge, flexibly useful for working in situations of unpredictability. Working with the uncertainty of future forecasts related to the effects of climate change and coastal city transformations, having an ecological approach that takes into consideration the different environmental dynamics with a holistic vision, constructing and evaluating future adaptation scenarios make research-by-design an appropriate working tool to cope with the issues that climate change requires to tackle in urban planning.

Resilience has become a key objective in urban and non-urban transformation operations, subjected to extreme catastrophic events [11]. The system’s resilience, in this process of risk management, is interpreted as the ability to anticipate, prepare and respond to threats imposed by alteration with the minimum damage that involves the social, economic and environmental profile; this concept within the process implies the objectives, strategies, hypotheses and the drafting of adaptation plans.

Through the study of the impacts, and future forecasts of the effects induced by climate change, two main starting adaptation strategies are here designed, aiming to face the problem of water during events of urban flooding “from below”¹ and “from above”². These two aspects should contribute to increasing the strength of the entire urban area.

The first step consists in the basic knowledge given by the scientific literature, that shows the observations of future forecasts at a global scale [7], as opposed to the local scale of the city of Lisbon [5], in which the downscaling of forecasts is defined: the worst effects of climate change will result into an increase of the average sea level affecting not only coastal areas but also transition environments such as estuaries and, in this case, the Tejo River, also influenced by rainfall dynamics.

The Town Council, together with a research center at the University of Lisbon, developed scenarios over a time frame which looks into 2100, the date on which the worst effects are expected to occur. Temporal analysis, 2025-2070 and 2100 [5], has allowed to analyze scrupulously the data relative to the amount of volume of water expected for the superficial outflows in the inside part and the data in order to characterize the amount of volume of flood water caused from the raising of the average sea level.

The action of adaptation to these phenomena coming "from below" faces a reality that can see no other device than the redesign of the whole river bank in the southwestern area, in order to reduce vulnerability.

¹ Expected sea level rising for 2100, referring to areas that develop from the bank of the river up to 5=10 m of altitude (*efeito do mar*).

² Runoff through the whole catchment sub-basins.

The area behind the river bank is characterized by urban valleys and by an excessive waterproofing of soils, that will make it be affected by further aggravating phenomena. Because of the valleys and of the runoff it becomes necessary to identify surface outflows through the Curve Number [8] method per each sub-basin, which confirms the danger and instability of the soil at the onset of extreme weather events, such as heavy rainfall and flooding. Starting from the catchment area scale is crucial to obtain a detailed framework on how to deal with the problem without neglecting some critical situation being exposed to change.

Results and Discussion

Through the identification of the criticalities of the river bank and the area behind, due to the possible raising of the level of Tejo river and to the increase in heavy rainfalls, through the definition of objectives and the priority areas of intervention it has been possible to design three scenarios for 2100, in which the focus is on coping with the two problems related to water, "from above" and "from below".

For what refers to water "from below", Lisbon's sea level expected by 2100 increase by + 5.69 m a.s.l. [1], exposing the entire river bank to high risk of flooding (Figure 1).



Figure 1 - Map of the elements exposed to risk for the expected sea-level rise (1 buildings at risk of instability: location on slopes starting from water channels up to 100 m away; 2 buildings at risk of submergence: placement within river channels - depressed areas; 3 flood risk buildings: location in the first 5 m of the *frente* starting from the river).

While the sea level of reference is fixed, for water "from above" the runoff depends on land use in proposed scenarios. Through the above-mentioned Curve Number method [9], simulations of different runoff and the consequent flooding risks are provided.

The different scenarios, each one through the implementation of measures to secure elements at risk (population, historical monuments, museums, hospital) in coherence with the current urban context, give a new design to the shore.

The first one (Figure 2), the safest among the three, proposes a re-naturalization of the river banks and the valleys, in order to "absorb" different qualities and quantities of water, "from below" and "from above", in a more resilient and flexible configuration that allows different tidal intervals, either in relation with runoff or not. The first one, the safest among the three, proposes a re-naturalization of the river banks and the valleys, in order to "absorb" different qualities and quantities of water, "from below" and "from above", in a

more resilient and flexible configuration that allows different tidal intervals, either in relation with runoff or not. The behaviour of the whole urban ecosystem, in this case, is similar to the one of the Venetian "barena" (lagunar saltmarsh) in which —depending on tidal oscillations— some lands emerge or are submerged.



Figure 2 - Scenarios of re-naturalization of river banks and valleys.

The other two scenarios don't work so much with nature-based solutions, but select some public buildings that should be taken out of risk (hospital, museums, monuments, etc.), "sacrificing" other areas along the river banks to provide "room for water", especially for volume rising "from below".

In the second scenario (Figure 3), some "bays" are obtained by excavating the river banks, also in order to close the life-cycle "from-cradle-to-grave" by re-using—at least partially—the demolition wastes to build "dikes" that would protect the public buildings from flooding risk, obtaining a sort of "promontory" per each public building that keeps its accessibility but could be also reached by boat, re-activating existing stations.

In the last proposed scenario (Figure 4), "bays" become so huger that the "promontories" per each public building become islands. Accessibility changes, losing almost all shoreline roads by excavating the river banks until the limit represented by the railway (that, instead of as a "dike", works as a gravel draining filter). This scenario has a peculiarity: it can be alternative to the others and, at the same time, it can represent an "incremental" evolution of the second one, in case the reality of climate effects on the estuary along the time would be worse than expected scenarios.



Figure 3 - Scenario of “bays” excavated in the river banks and “promontories” to host public buildings made safer from flooding risks.



Figure 4 - Scenario of “islands” instead of “promontories” to host public buildings.

Scenario 1: new classification of land use and buildings at risk



Scenario 2: new classification of land use and buildings at risk



Scenario 3: new classification of land use and buildings at risk



Figure 5 - Comparison between the consequences of each proposed scenario.

Conclusion

The results obtained offer a technical support in the decision for urban adaptation to the effects of climate change.

The three scenarios proposed in this work outline a series of long-term measures to support the river bank, becoming an effective tool to adapt the urban area of the south-west part of the catchment area, classified after multiple studies as a vulnerable area, through proposals to redesign the river bank. To furthermore support the decision, per each scenario some data are provided: land use measures, buildings to demolish or re-locate, interventions on accessibility, mobility and transport infrastructures.

As can easily be seen in Figure 5, the most preferable and flexible scenario, the first, requiring nature-based interventions implies harder policies of re-localisation and demolition that compromises the feasibility and the political and financial sustainability of the proposal. The other two scenario, as above mentioned, can even be one consequent to the other, implying an equally flexible and evolutive response to the flooding risk. Nevertheless, the last one is more extreme and requires stronger interventions on the mobility system, that suggest to choose the other alternative and change orientation only depending on real level of sea rise and environmental change, that could justify this choice as a sort of second chance.

The interventions chosen for the scenarios can not only define different responses to the trend of climate effects, but also verify the adequateness of forecasts and any changes in the long term.

References

- [1] Antunes C., (2016) - *Monitoring sea level change at Cascais tide gauge*, Journal of Coastal Research, vol. 64, pp. 870-874.
- [2] Bussadori V. (2013) - *La Pianificazione come strumento di adattamento ai cambiamenti climatici*, in Musco F., Zanchini E. (eds.), *Il Clima cambia le Città*. Atti della conferenza, Corila, Venezia, pp. 20-22.
- [3] Camara Municipal de Lisboa, (2017) - *EMAAC- Estratégia municipal de adaptação às alterações climáticas de Lisboa*, Lisbon.
- [4] Costa J., Figueira de Sousa J., Matos Silva M., Santos Nouri A., (2013) - *Climate change adaptation and urbanism: A developing agenda for Lisbon within the twenty-first century*, Urban Design International, vol. 19, pp 77-91.
- [5] Da Cunha L.V., Proença De Oliveira R., Nascimento J., Ribeiro L., (2007) - *Impacts of climate change on water resources: a case-study for Portugal*, Water in Celtic Countries: Quantity, Quality and Climate Variability. Proceedings of the Fourth InterCeltic Colloquium on Hydrology and Management of Water Resources, Guimarães, Portugal, IAHS Publ., vol. 310, pp. 37-48.
- [6] Holling C. (1973) - *Resilience and stability of ecological system*, Annual Review of Ecology and Systematics, n. 4, pp. 1-23.
- [7] IPCC (2014) - *Summary for policymakers*, in Id., *Climate Change 2014: Impacts, Adaptation, and Vulnerability. Part A: Global and Sectoral Aspects. Contribution of Working Group II to the Fifth Assessment Report of the Intergovernmental Panel on Climate*, Cambridge University Press, pp. 1-32.

- [8] Mishra S.K., Singh V., (2003) - *Soil Conservation Service Curve Numer (SCS-CN) Methodology*, Springer, Dordrecht.
- [9] Nijhuis S., Stolk E., Hoekestra M. (2017) - *Teaching Urbanism: the Delft approach*, Urban Design and Planning, n. 170, issue DP3, pp. 96–106.
- [10] Stern N. (2007) - *The Economics of Climate Change: The Stern Review*, Cambridge U.P., Cambridge MA.
- [11] Walker B.H., Salt D. (2006) - *Resilience thinking: Sustaining ecosystems and people in a changing world*, Island Press, Washington DC.

LAKE GARDA LEMON HOUSES: A MEDITERRANEAN LANDSCAPE IN AN INTERNAL LAKE

Alberta Cazzani¹, Stefano Barontini²

¹Politecnico di Milano, DASTU

phone +39 02 2399 5026, e-mail alberta.cazzani@polimi.it

²Università degli Studi di Brescia, DICATAM, via Branze, 43, I-25123 Brescia (IT)

phone +39 030 371 1280, e-mail stefano.barontini@unibs.it

Abstract – Lemon houses (locally, *limonaie*) are ancient terraced citrus gardens that still shape the landscape of a wide area along the NW shore of Lake Garda (Northern Italy). Here, thanks to lake's microclimate, to SE exposure of the gardens and to the development of an original agricultural technique, lemon houses allowed a fruitful and international citrus trade that, already settled during the 16th Century and despite the sensitivity of lemon trees to cold temperatures, flourished during the Little Ice Age and reached its maximum development between the 18th and 19th Century. Now, that the citrus trade is no more central for the economy of the area and the citrus cultivation has become ancillary to other functions of the landscape, in view of designing future scenarios for that area, we propose an interpretation of Lake Garda *limonaie* as a deeply anthropogenic, labour intensive, multifunctional landscape that, not only in the local flora and in the steep calcareous slopes, but also in its bioclimatic adaptation and in the central role of the irrigation as an axle of the citrus cultivation, shares many characteristics with the symbiotic relationships established between humans and nature, typical of the oases of the wider Mediterranean basin. We therefore conclude that any intervention which aims at preserving the fragility and peculiarity of the area, as well as the intangible cultural heritage of the citrus cultivation, should be framed in a holistic agroecosystemic perspective, deeply rooted in the knowledge of lemon houses' past.

Lemon houses and Lake Garda

When Renaissance agronomist Agostino Gallo, from Brescia, dealt with citrus fruit growing in the Seventh day of *The twenty days of agriculture and the pleasures of the villa...* [14], he introduced the theme by comparing the peculiar climatic and vegetative conditions of Lake Garda NW shore, in Northern Italy, to those of Ligurian and Southern—Italian coasts, and he stated that he would not have treated of citrus fruit growing in these areas, in favour of those cultivated along Lake Garda shore. The recognition of typical Mediterranean features in Lake Garda landscape and climate is in fact ancient, and particularly the coast running for some tens of kilometres from Salò to Limone is exceptionally rich in Mediterranean flora and agriculture, as holm—oaks, cypresses, capers, laurels, myrtles, agaves, olive groves, vineyards and, particularly, citrus groves.

This peculiarity is due both to the presence of a great lake and to the local geomorphology. The lake (with a surface of 370 km², a volume of about 49 km³ and a contributing basin of 2260 km², measured at the lake outlet) locally mitigates the climate.

The presence of a calcareous—rock barrier, uphill the cultivated area and facing SE, protects from winds and allows to store the Sun heat, thus reducing daily temperature excursions. The territory, naturally prone to Mediterranean cultivations, was continuously and intensively modified by anthropogenic action since the 15th Century. The slopes were terraced with dry—stone walls and landfill, in order to cultivate citrus, olives and grapes, which sustained a flourishing economy for about five centuries.



Figure 1 - *Limonaie* characterise the landscape, with their system of terraces and pillars, Limone (Lake Garda, Italy. Postcard, first 1900s).

The most typical cultivation of Lake Garda Western shore has undoubtedly been the citrus fruit growing, already documented since the 15th Century [4, 5, 9, 11, 12, 13]. This cultivation shaped the shore, particularly in Gargnano, Limone and Toscolano Maderno, with many lemon houses (locally: *limonaie*, Fig. 1) linked with a dense network of features (irrigation channels, storage houses, roads, cypress trees planted as windbreaks or rockfall barriers and chestnut groves to provide the required wood). *Limonaie* are traditional local structures, unique of their kind, to cultivate citrus trees in terraced gardens, exposed to the Sun and protected from the winds by great walls. They were transformed into greenhouses during cold months (from November to March), because citrus trees, planted in whole soil, cannot bear cold temperatures. Since their first appearance, lemon houses rapidly gained a remarkable degree of standardization, both in the structures and in the agricultural technique. In order to face the great amount of water required by citrus trees in wet climates, and the structural water scarcity of the soil along steep slopes, the lemon houses adopted a very precise irrigation system, based on the use of flumes to distribute the water tree by tree, typical of many Mediterranean water—scarce cultivations (Fig.2). These protective structures – together with the lake’s warmer microclimate – made Garda Lake the Northernmost point in the world where lemons grown commercially. At 600 meters above sea—level, Garda lemons are also the highest. In the gardens, particularly lemons

and citrons were cultivated, mainly to be exported in Northern Europe. In the middle of the 19th Century, at the time of their maximum development, almost 50 hectares of land were devoted to citrus fruit growing, with about 35 000 productive trees and an average amount of harvested lemons ranging between 15 and 20 millions of units.

The deep social and economical changes of the 20th Century, viz the development of transportations, the discoveries in the pharmaceutical fields which reduced the preciousness of citrus fruits and laurel, the intense tourist development of the area, together with some diseases which affected the trees, dramatically conflicted with the great cost of skilled manpower which was required to produce citrus fruits in this area. Citrus fruit growing lost its economical return and has been slightly abandoned. Now Lake Garda lemon houses, even if rarely cultivated and only partially conserved in all their structural components, still represent an emblem of NW Lake Garda landscape and a unique heritage which still requires to be investigated, protected and set off [1, 5, 8, 13].



Figure 2 - Inside a recently restored *limonaia* in Gargnano in Winter months: the *limonaia* is closed and covered. The irrigation system and many features of traditional citrus fruit growing may be recognized.

History and architecture of lemon houses

The history of the lemon groves of upper Garda covers a period of over seven Centuries, from the date of the introduction of the first lemon trees at the end of the 13th Century until today. The development of the *citrus gardens* was gradual and progressive, until reaching maximum expansion and productivity in the mid—19th Century. Local tradition, as reported by Giuseppe Solitro in 1897 [18], attributes the first introduction of

lemon in the upper Garda in the 13th Century by a monk who planted in the Gargnano Franciscan convent – founded before 1266 by San Francesco himself – a citrus tree probably coming from Liguria or Sicily. In support of this tradition, lemons, oranges, citrons and Adam's apples are carved on the 14th Century capitals of the convent cloister.

The creator of the monumental terraced buildings, nor the start of their construction is unknown. However, the presence of citrus groves had made the NW Garda shore special and extraordinary since the 15th Century: for Felice Feliciano in 1464, Toscolano was “embalmed with the scent of citrons” and “shaded by the leafy branches of lemons and citrons” [11, 12]. Even Marin Sanuto who in 1483 describes *Zardini de zedri, naranzari and pomi damo* (“Gardens of citrons, oranges and Adam’s apples”) [11, 12] and Jacopo Bonfadio in 1548 reports orange, lemon and citron gardens and highlights the strong connection between natural and cultural landscape: “The gardens here are the gardens of the Hesperides and Alcinous and Adonis. The countrymen industry has done so much that Nature incorporated with art [of agriculture] has itself become an art and together they have produced a third Nature to which I cannot give a name” [7, 12]. It is therefore demonstrated that if the cultivation of citrus fruits could already be widespread from the 14th and 15th Century, in the 16th Century the architectural layout of the *limonaie* was designed and set in all the components that we can still notice today. In this regard the aforementioned Agostino Gallo in 1569 [14] describes the *limonaie* completely defined in the architectural components, constructive techniques, materials and maintenance practices. The cultivation of citrus fruits initially spread to Maderno, Toscolano and Gargnano. Even if in Limone the presence of lemon groves has been documented since the beginning of the 17th Century, it was the noble Bettoni family who, starting from the end of the 17th Century, built monumental *limonaie* in Limone for an intense lemon production aimed at high profitable marketing [11, 12, 13, 19].

Even today the *limonaie* are a distinctive landscape feature, particularly the tall, stone perimeter walls, some of them eight to ten meters high, built on the terraced land to protect lemon trees from the winds that blow down from the mountains behind. Thin stone pillars stand sentry—like along the terraces, built to secure a grid of wooden beams. During the Winter months, the *limonaie* were closed by wood plank roofs and large window panels facing the Sun, turning the structures into seasonal greenhouses. The wood parts that were used to cover and close the *limonaie*, were put away during Spring and Summer in tall store storehouses called *caselli* that stood next to the lemon houses themselves. They were necessary for storing materials, but also for the covering and opening works.

The Garda lemon growing was extremely labour—intensive. Building the structures was only the first step. They must be maintained, closing and opening them with the seasons, lighting fires inside when the temperature drops below freezing, cultivating and watering the trees, harvesting and distributing the fruits. All the effort was worth it though because lemon growing was highly lucrative. Most of the money made from Garda lemons was from exports to Central and Northern European countries. There was no real competition, as lemon from the South of Italy would not last long enough to reach all the markets where Like Garda lemons were distributed. Their durability remained a key competitive advantage well into the 20th Century. Giovanni Barbaro in 1614 wrote: “This area abounds with oranges, citrons and wonderful sort of lemons... The owners make great profits by selling them in German lands and especially lemons, though they spend a lot of money in the upkeep of their gardens” [7].

The lemon industry was highly organized. In 1840, *limonaie* owners founded the Società Lago di Garda, a pioneering agricultural cooperative, whose historic headquarters can still be seen abandoned at the edge of Gargnano [6,10,17]. There were the golden years, when Gargnano – center of citrus fruit growing – produced 4 to 5 million lemons a year, out of a total for the area of 6 to 7 million. The years of maximum production of the Società Lago di Garda were those between 1840 and 1860, with about 125 million total lemons delivered, with a peak of 9.7 million in 1852 (of which 7 million from the Gargnano lemon houses). The Società Lago di Garda organized the collection and separation of the lemons into categories, from superior to poor. Then they were shipped to Desenzano, the largest town on the lake, where they were mostly sold to German agents and prepared for shipping to Austria—Hungary, Prussia, Russia, the Ottoman Empire, Britain, Sweden and Denmark. Only the poorest quality lemons were consumed locally [5]. However, at the end of the 19th Century production started to decline and the entire lemon growing culture was abandoned. Since then, the landscape has changed. Many *limonaie* have been left to decay and collapse, others have been converted into other agriculture purposes or into houses.

Traditional irrigation system

The link between the lemon houses and the irrigation is deep and the importance of the irrigation for the gardens has been already recognized in ancient times. Agostino Gallo, even if referring that some gardeners used to irrigate the trees, and other ones still not, reports in the cited Seventh day [14] that irrigated trees give much more numerous, beautiful and early fruits than the not—irrigated ones. He therefore states that gardeners, who don't have commodity of sources, wells or cisterns nearby the garden, devote a great labour to bring the water to the trees, as any one of them requires more than two *brenta* of water each irrigation. *Brenta* is a vernacular word standing for the Italian *gerla* and for the Venetian *zerla*, which means wicker pannier. Traditional wicker panniers' volume is some tens of litres but the word *zerla* was used also as a volume measurement unit for liquids and corresponded to 49.7427 litres [15]. This note reported by Agostino Gallo is therefore in agreement with (and a lower limit of) the more recent traditional practice according to which each tree would require between 100 and 300 litres for each irrigation during the warm season. The difference between the two data might account for the fact that Gallo's knowledge of the local agriculture reflected the climatic conditions of his era, at the beginning of the Little Ice Age. Accounting for the presence of one productive lemon tree in every space between two pillars, for the citron trees between them and for the nursery, each terrace of a garden had many tens of trees. These little data gives a rough idea of the great amount of water required for each irrigation, so that an irrigation system was not only needed, but it fastly developed and soon gained a remarkable degree of standardization as the other features of *limonaie*. Moreover, the necessity of water availability nearby the gardens contributed to shape the landscape as well as the necessity of solar radiation, so that many terraces clung to the rocks of the slopes in order to being near to the sources.

The traditional hydraulic system of the *limonaie* is divided into three fundamental parts: (1) the water collection and storage works, (2) the water distribution network inside the lemon houses and (3) the drainage network to remove the excess water. The collection and storage works are always upstream of the garden or, more commonly, of the system of

gardens which were irrigated with the same water supply. These works are in turn of three types: direct water intake from a stream, storage tanks and natural or artificial sources. The direct intake from a stream was separated from the irrigation channels by a stilling basin, from which the water was usually taken by means of a submerged intake, as it is common in many traditional irrigation systems. Tanks' volume ranged from about 1 m^3 to some hundreds of cubic meters (as for the big reservoir upstream of the lemon houses of Bettoni family in Bogliaco, nearby Gargnano), depending if they were used only as stilling basins or partitioning basins, or they were used as a reservoir for big *limonaie* systems. The pumping of water directly from the lake was introduced in recent times and it is practiced only for those gardens that are located on the lake shore.

The water, conveyed by means of the external works toward the upstream terrace of the garden, was distributed to the plants by means of flumes that run along the retaining walls upstream of the terraces and are equipped with at least one little rectangular spillway at each field, i.e. every 4 m or 5 m (Fig. 2 and Fig. 3). The traditional flumes were mostly made of pink marble or grey sandstone, both being common in the area. Particularly the pink marble, from Verona caves, was used in the lemon houses for all the most relevant stone details. Some flumes may be found also built in sided—up roof tiles but they should be attributed to more recent interventions. The flumes were sustained by brackets or, sometimes, by pillars, at a height ranging between one and two meters from the base of the wall. The measured slopes of the flumes range from 0.01 m/m (e.g. in the *limonaia Pra' de la Fam*, Tignale) and 0.1 m/m (e.g. in the *limonaia La Malora*, Gargnano). In the same *limonaie*, measured flume sections are (reversed) trapezoidal and range 11 cm to 12.5 cm for the larger base, 5 cm to 5.5 cm for the smaller base, and the depth is about 6.5 cm. It is worth noting that almost all the observed sections, also in other lemon houses, show the same shape and dimensions, which are close to the section of least hydraulic resistance.

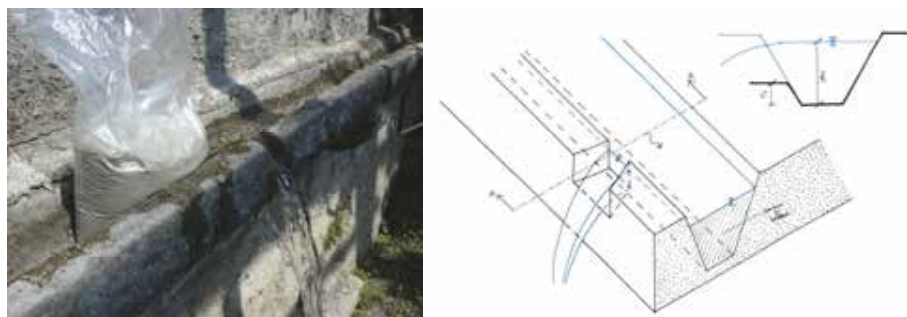

Figure 3 - Spillway, activated by the backwater of a sand bag, at *limonaia La Malora* (Gargnano, left) and sketch of a typical section of a flume with the activated spillway, as measured at the *limonaia Pra' de la fam* (Tignale, right), [3].

An underground pipe covered with stone slabs, the *caladria*, allowed the water to flow down to the terrace downstream. At the *La Malora* lemon house a *fistula* brick segment was observed that was probably part of a *caladria*. Such frustum—of—cone shape

is locally very common for small pipes since the Roman Era. Even if during the inspections carried out some small variations were observed in the slope, in the section dimensions of the channels and in the shape of the section of the spillways, it was verified that the internal water distribution system was characterized by a meaningful degree of standardization, as the other functional elements of *limonaie*.



Figure 4 - *Fistula* of a *caladria* discovered by the owner at the lemon house *La Malora* (Gargnano).

In order to irrigate the plants, each spillway was activated with the tailwater induced by means of a sandbag put across the flume, downstream of the spillway. The slope of the flume was such that only one spillway is activated at a time, and the irrigation was performed plant by plant, from upstream to downstream. The spilling water was conveyed into a pond at the foot of the plant by means of a wooden (orthogonal) dihedral. During previous flow measurements [3], it was verified that most of the spillways were capable of delivering flow rates between 7 litres and 15 litres per minute, with quite a small discharge coefficient (with respect to theoretical values) which deserves to be further investigated. Such discharge made it possible to supply the irrigation needs of 100 litres to 300 litres per plant, every eight days in the warm season, in a time interval from 10 minutes and just over half an hour. Since it was possible to activate only one spillway at a time, considering the large number of adult and young trees for each terrace, we may conjecture that in the warm season the water distribution was almost continuous.

A Mediterranean landscape and its present days

The complexity of the irrigation system, the detail with which special parts were carved into the rock and the central role played by the irrigation in the lemon groves, also at shaping the systems of lemon houses, evidences the typical patterns of the water—scarcity irrigation. This observation might be paradoxical in a wet climate as that of Lake Garda is,

but it is justified by the great amount of water required by citrus growth (especially at mid—latitudes) and by the difficulty of managing the water on the steep slopes of the NW Lake Garda shore. A typological comparison, between the traditional irrigation of lemon houses and other traditional irrigation systems in the Mediterranean basin, makes it much more similar to the irrigation system of Spanish—Arabic gardens than to those of the inner Alps (see e.g. the Swiss *bisse* and *suonen*). This is remarkable because nearby the lemon houses district, in the river Chiese valley on the NW slopes of the same hills, an important productive district of hydraulic factories was supplied, in the same era, by channels that are typical of the inner Alps [2]. Not only the irrigation, but also the selection of local and valuable varieties destined for trade (the Salò citron, and the Maderno lemon, called *madernina*) and of ancillary varieties (laurels, capers), the contribution of skilled workers that developed a standardized production system deeply adapted to the territory, the ability of the gardens to face the climatic changes – it is worth noting that the gardens, despite the sensitivity of lemon trees to the cold, had their maximum development during the Modern Age, that is in the midst of the Little Ice Age –, the relationships with the networks of supranational trade, all these characteristics make it possible to speak of Lake Garda *limonaie* as of an oasis, where the echoes of the wider Mediterranean basin are perceived, where the deeply anthropogenic landscape is characterized by a structurally symbiotic relationship between humans, nature and climate, and where the agricultural practice naturally aimed at preserving the functions of the ecosystem (Fig. 5).



Figure 5 - The NW Lake Garda landscape, still notably characterized by several *limonaie* at different levels of conservation, connected to other traditional Mediterranean crops as olive groves, vineyards, laurel groves, meadows and woods.

Today it is particularly important to set conservation and recovery treatments not only considering the maintenance of the historical landscape and documentary value of the lemon houses, but also including the agronomic and productive one. In this sense, there is a risk that historical cultivation techniques will be lost and that construction elements, materials and plant species that are not compatible with the local and traditional landscape will be introduced. Although awareness of the unique and exceptional value of the *limonaie* landscape is growing, there is still the risk of losing the peculiarities of the tangible heritage and above all of the intangible heritage related to them. The *limonaie* landscape is the result of a complex process of territorial transformation and of a continuous maintenance work carried out by farmers and gardeners for centuries [5]. The future management of this unique traditional rural landscape will be possible only if policies and strategies, aimed at the knowledge, dissemination and promotion of this exclusive heritage, are defined.

The future of *limonaie* is yet to be written

The lemon groves have long been part of Lake Garda landscape. Goethe noted in 1786, discovering Limone, that “the terraced gardens planted with lemons, give a feeling of order and wealth. The entire garden is adorned by white, square pillars, all in row, each a certain distance from the others, in such a manner as to resemble a staircase, gradually climbing up the side of the mountain” [7,11]. This complex landscape system was set and built without an architect plan. In this regard, *limonaie* are considered by Bernard Rudofsky “architectures without architects”. He defined the Lake Garda *limonaie* like “skeletal architecture”, underlining “the charms of this exotic architecture” that he picked for the cover of the first edition of his book [16]. Rudofsky rightly claims that: “Vernacular architecture does not go through fashion cycles. It is nearly immutable, indeed, unimprovable, since it serves its purpose to perfection. As a rule, the origin of indigenous building forms and construction methods is lost in the distant past.” The fact that *limonaie* have lost their economic importance has led to the loss of management skills and has caused the current decay and fragmentation of a complex system. However, the *limonaie* – in different states of conservation – are still typical components of NW Lake Garda landscape and provide an architectural—cultural heritage that is unique in the world [1, 5, 8].

If seen under the light of the paradigm of the oasis, it is possible to recognize in the lemon houses not only the historical and aesthetic function, linked to the conservation of their memory and of the value of the landscape, but also the whole wide range of functions and ecosystem services recognized in the Millenium Ecosystem Assessment and that are specific to oases, such as the cultural role played in the networks of the international trade, the function of agri—food supply, and the regulatory function of biodiversity on the climatic changes and that of the terraces on the hydrogeological hazard. The agri—food supply function is not related only on the citrus production – traditionally devoted to the trade –, but also on the ancillary horticultural productions, which are traditionally oriented to local consumption. As well as the oases, the lemon houses are fragile, because they are anthropogenic ecosystems, and they require to be faced as a whole agroecosystem, thus going beyond the bifurcation between musealization and touristic vocation, from one hand, and abandoning and change of destination, from the other hand. Moreover, to convey them back, to their pristine agricultural vocation via an agroecological

perspective, might partially readdress the nowadays mainly touristic vocation of Lake Garda. The knowledge of the mass, energy and labour fluxes which shaped the landscape are crucial to reconnect the architectural and cultural fragments of its nets, and any intervention, which aims at preserving the fragility and the peculiarity of the area, should be framed in a holistic agroecological perspective, deeply rooted in the knowledge of lemon houses' past. In this way the peculiarity of Lake Garda lemon houses will be preserved and they will provide all the services they can, thus opening a range of possible scenarios which, alongside the conservation and musealization of the structures and of the cultivation technique as an immaterial cultural heritage, will combine the integration with supranational cultural paths with the return to a renewed agroecological productive vocation. The unique architecture of the *limonaie* must be considered as the result of a particular and complex historic landscape project that needs to be analysed and surveyed, to prepare re—use and management plans and define conservation treatments and standards for the preservation and valorisation of this exceptional tangible and intangible heritage.¹

References

- [1] Badiani B., Barontini S., Bettoni B., Bonati S., Peli M., Pietta A., Scala B., Tononi M. & Vitale N. (2017) *Lake Garda lemon houses (Italy): Opportunities of a sensitive, marginal area in urban planning*, Change and Adaptation in Socio—Ecological Systems, doi: 10.1515/cass-2017-0010, 3 (1):111–118.
- [2] Badiani B., Scala B., Barontini S., Aliverti L. & Ghirardi A. (2020) *Gli opifici idraulici della Valle Sabbia. Conoscenza e conservazione*, Nardini Editore, Firenze.
- [3] Barontini S., Vitale N., Fausti F., Badiani B., Bettoni B., Bonati S., Cerutti A., Peli M., Pietta A., Ranzi R., Scala B., Tononi M. & Zenucchini V. (2016) *L'irrigazione tradizionale delle limonaie del Garda tra scarsità idrica e antropizzazione del territorio*, in Proceedings of the XXXV Convegno Nazionale di Idraulica e Costruzioni Idrauliche, Bologna, 14–17 September 2016, doi: 10.6092/unibo/amsacta/5400, pp.1235–1238.
- [4] Bettoni L. (1879) *L'Agricoltura nei contorni del Lago di Garda*, Tip. Bernardoni di C. Rebeschini, Brescia.
- [5] Cazzani A., Sarti L. (1992, 1997) *Le limonaie di Gargnano. Una vicenda, un paesaggio*, Grafo, Brescia.
- [6] Cazzani A. (1997) *La Società Lago di Garda: uno storico fulcro dell'economia gardesana*, in: AA.VV., “La chiesa di San Francesco e la Società Lago di Garda a Gargnano”, Grafo, Brescia, pp.67-91.
- [7] Cazzani A. (edited by) (1999) *Giardini d'agrumi. Cedri, aranci e limoni nel paesaggio agrario italiano*, Grafo, Brescia.
- [8] Cazzani A. (2007), *The limonaie of Garda Lake: a Cultural Landscape to preserve*, in: AA.VV., “Orangerien in Europa von Fürstlichem Vermögen und Gärtnerischer

¹The present paper was conceived and written jointly by the two authors. In particular, Alberta Cazzani developed Sections: *Lemon houses and Lake Garda, History and architecture of lemon houses*; Stefano Barontini developed Sections *Traditional irrigation system, A Mediterranean landscape and its present days*. The authors collaborated in the writing of the *Abstract*, of *The future of limonaie is yet to be written and for the final revision of the manuscript*.

- Kunst”, ICOMOS, Hefte des Deutschen Nationalkomitees – Journals of the German National Committee, n.XLIII, ICOMOS, Nationalkomitee der Bundesrepublik Deutschland, pp. 71–77.
- [9] Cigognetti G. (1988) *Architettura bioclimatica e territorio: le limonaie del Lago di Garda*, Abacus (13):16–25.
- [10] Erculiani G. (1940) *La Società Lago di Garda*, R. Codignola, Brescia.
- [11] Fava D. (1985) *I limoni a Limone sul Garda*, Cassa Rurale e Artigiana di Vesio Tremosine, Tip. Squassina, Brescia.
- [12] Fava D. (2005) *Limonaie e limoni a Limone sul Garda*, Grafo, Brescia.
- [13] Fava D. (2006) *Tra le limonaie di Limone sul Garda. Un percorso tra storia e cultura*, Comune di Limone sul Garda, Grafica 5, Arco.
- [14] Gallo A. (1569) *Le vinti giornate dell'agricoltura et de' piaceri della villa delle quali sette non sono più state date in luce, & tredici di nuovo son ristampate con molti miglioramenti*, Appresso Gratoso Percaccino, Venezia.
- [15] Martini A. (1883), *Manuale di metrologia, ossia misure, pesi e monete in uso attualmente e anticamente presso tutti i popoli*, Loescher, Torino.
- [16] Rudofsky B. (1964, 1987), *Architecture Without Architects*, University of New Mexico, Albuquerque.
- [17] Samuelli T. (1883), *Origine della Società Lago di Garda*, Tip. Conter, Salò.
- [18] Solitro G. (1897), *Benaco*, Giò Devoti, Salò.
- [19] Tedeschi P. (2019), *The noble entrepreneurs coming from the bourgeoisie: Counts Bettoni Cazzago during the nineteenth Century*, Business History, doi: 10.1080/00076791.2019.1653283.

DISTRIBUZIONE DEL MARINE LITTER NELLE SPIAGGE DELLA SARDEGNA: IL CASO DI CALA DEI PONZESI E DI CALA SPALMATORE NELL'ISOLA DELL'ASINARA

Corinne Corbau¹, Massimo Contini², Vittorio Gazale³, Alexandre Lazarou²,
Umberto Simeoni¹, Donatella Carboni² *

¹Università degli Studi di Ferrara, Via Saragat, Ferrara, cbc@unife.it, g23@unife.it

²Università degli Studi di Sassari, Via Roma, Sassari, carbonid@uniss.it; * Autore di riferimento
contini.mas@gmail.com; alexandros.lazarou@gmail.com

³Parco Nazionale dell'Asinara- gazale@asinara.org

Abstract – Marine litter is human-created waste that has been discharged into the coastal or marine environment. Specifically, marine litter (or debris) is defined as “any anthropogenic, manufactured, or processed solid material (regardless of size) discarded, disposed of, or abandoned in the environment, including all materials discarded into the sea, on the shore, or brought indirectly to the sea by rivers, sewage, storm water, waves, or winds” [1; 2].

Furthermore, plastic pollution in aquatic systems is an emerging problem that is gaining worldwide attention in particular because their extensive use and applications favour their presence as a result of improper waste management as outlined by Jambeck et al. [3], but the reuse and recycling of end-of-life plastics is very low. One way to reduce plastic pollution is to increase the knowledge and understanding of plastic pollution among people.

The present study aims to analyze and to quantify the abundance, weight and compositions of marine litter along two beaches of Asinara Island (Cala dei Ponzesi and Cala Spalmatore, Sardegna, Italy) during three surveys (winter 2017, spring 2019 and summer 2019). The method used for the marine litter characterization was based on the guidelines of UNEP [4; 5], of the Joint Research Centre [6] and on the IPA ADRIATIC project DEFISHGEAR. The preliminary results indicate that 1917 items have been collected at Cala dei Ponzesi (about 1,9 items/m²), while 816 items have been identified during the two surveys of 2019 (about 2 kg, with a density of 0,81 items/m²). At Cala Spalmatore, 289 marine debris have been collected during the two surveys of 2019 (about 3 kg with a density of 0,21 items/m²).

Furthermore, from the analysis of the marine debris, it appears that plastic is the most important category of litter and, plastic fragments, lolly sticks, plastic caps/lids unidentified and string and cord (diameter less than 1 cm) are the most frequent debris.

1. Introduzione

Secondo lo *United Nations Environment Program* (UNEP) il *Marine Litter* è qualsiasi materiale solido scartato, fabbricato o trasformato, smaltito o abbandonato in ambiente marino o costiero¹ [7]. Si tratta di materiali durevoli e persistenti che, originati da attività umane, arrivano in mare per diverse ragioni e finiscono con il galleggiare, arenarsi

¹ “*Marine litter is any persistent, manufactured or processed solid material discarded, disposed of or abandoned in the marine and coastal environment*”, [7]. <https://www.unenvironment.org/explore-topics/oceans-seas/what-we-do/working-regional-seas/marine-litter>, consultato il 23/06/2019.

sulle spiagge (il *Beach Litter*) o, ancor peggio, con l'annidarsi nei fondali.

In generale si può dire che i rifiuti marini hanno due origini: fonti di origine terrestre e fonti di origine marina.

Per Jambeck et al. [3] circa l'80 % dei rifiuti marini globali proviene da fonti di origine terrestre. Per quanto riguarda le spiagge e i mari più frequentati, una delle fonti principali di inquinamento da rifiuti solidi è il turismo. Ma le fonti di origine terrestre possono essere molte altre, per esempio:

- discariche comunali situate sulla costa o nell'entroterra;
- il trasporto fluviale dei rifiuti provenienti dalle discariche;
- lo scarico di acque reflue non trattate, compresa l'acqua piovana;
- la presenza di impianti industriali con il rilascio di rifiuti solidi [3];
- la perdita accidentale;
- l'evenienza di eventi climatici estremi [8] come tsunami o tempeste tropicali.

Solo il 20 % dei rifiuti in generale arriva da fonti di origine marina. Questi provengono per la maggior parte dal traffico marittimo di traghetti, navi da crociera e commerciali, pescherecci, flotte militari e di ricerca, imbarcazioni da diporto e installazioni offshore come le piattaforme e gli impianti di acquacoltura [9].

Sono diversi anche i fattori che intervengono perché una spiaggia possa trattenere i rifiuti o perderli in mare. A parte il regime onde-vento, che sembra influire molto sulla quantità di rifiuti raccolti sulle spiagge, l'orientamento e la geomorfologia di ciascuna spiaggia sono considerati ugualmente importanti. Oltre ai fattori naturali che influenzano la dinamica dei rifiuti da spiaggia, i fattori antropici come la vicinanza ai centri urbani, la densità di popolazione, i visitatori della spiaggia e il traffico marittimo svolgono un ruolo fondamentale per determinare la composizione e l'abbondanza del *Beach Litter* [10; 11].

In alcuni casi, le spiagge con attività balneari legate alla presenza dei turisti, hanno una densità di rifiuti locali ben al di sopra della media mondiale [12]. Infatti, la concentrazione di detriti e rifiuti sulle spiagge possono aumentare in estate fino al 40 %, a causa dell'alto numero di turisti. Infatti, in alcune zone turistiche, oltre il 75 % dei rifiuti annui sono generati in estate, poiché i turisti producono in media il 10÷15 % di rifiuti in più rispetto agli abitanti [8].

La presenza visibile di rifiuti marini ha un impatto sul valore estetico e sull'attrattiva delle spiagge e delle coste. Se la quantità e la visibilità del *Marine Litter* oltrepassa una certa soglia, può essere motivo per i fruitori di non visitare determinate aree costiere [13; 14], con importanti conseguenze sulle attività legate al tempo libero e al turismo balneare

Figura 1 - Gli oggetti più frequentemente trovati sulle nostre spiagge. Fonte: [20].
Figure 1 - The top waste items littering our beaches. Source: [20].



[15; 16; 17]. La presenza del *Marine Litter* può avere, inoltre, effetti a breve termine (ad es. quando un evento naturale specifico come un'alluvione o uno tsunami porta i rifiuti marini) e/o impatti a lungo termine (ad es. dove livelli costanti di rifiuti marini danneggiano la reputazione e l'immagine della zona come destinazione turistica scoraggiando così gli investimenti del settore privato) [18]. Questi impatti possono essere molto significativi in particolare laddove le economie locali dipendono fortemente dal settore turistico [19].

Oltre ad essere sgradevoli e antiestetici, i rifiuti marini possono comportare rischi per la salute e per la sicurezza di nuotatori, pescatori e di tutti coloro che utilizzano in qualsiasi modo la costa. Per esempio, i rifiuti industriali (ad es. fusti chimici, batterie ed elettrodomestici scartati) rilasciano composti tossici, mentre i rifiuti per l'igiene personale/medica (ad es. pannolini usa e getta e prodotti sanitari) contaminano l'acqua. Oggetti taglienti come lattine di metallo, siringhe e vetri rotti possono potenzialmente ferire i visitatori, mentre i bambini possono inghiottire oggetti più piccoli come mozziconi di sigarette, ecc. [20].

Tra tutti i rifiuti presenti nelle acque e nelle spiagge, i più numerosi e pericolosi sono le materie plastiche. Si stima, infatti, che la maggior parte dei rifiuti solidi rinvenuti nei mari del mondo (secondo gli studi variano dal 60 % al 90 %) siano materiali plastici [21], di cui circa il 62 % proviene dall'imbballaggio di cibo e bevande [8] [22] (Fig. 1 e Fig.2).

Si stima che vi siano in mare più di 5 miliardi di pezzi di plastica, con un peso di oltre 150 milioni di tonnellate [21], di cui tra 1,4 e 3,7 milioni di tonnellate solamente nei mari dell'UE [23]. Calcolare quanta plastica finisce in mare ogni anno è difficile; diversi studi hanno fornito diverse risposte con dati annuali. Tra gli studi i dati variano, alcuni di essi riportano:

- da 4,8 Mt all'anno a 12,7 Mt all'anno [3];
- 12,2 Mt all'anno [24];
- 10 Mt all'anno [25];
- 8,28 Mt all'anno [26].

Boucher e Friot [27], dopo aver analizzato i dati presenti in letteratura e i dati statistici sulla produzione di plastica, hanno calcolato che oggi la quantità di rifiuti plastici che finiscono in mare ammonta a 12 milioni di tonnellate all'anno, il 3 % della produzione di plastica globale. Si stima che, entro il 2025, gli oceani conterranno 1 tonnellata di plastica ogni 3 tonnellate di pesce ed entro il 2050 ci sarà nel mare, in peso, più plastica che pesce [21].



Figura 2 - Plastica negli oceani: un'emergenza globale. Fonte: [21, p. 6].

Figure 2 - Plastic in the ocean: a global emergency. Source [21, p. 6].

Un altro problema legato alla presenza di *Marine Litter* è la tossicità delle sostanze chimiche che accompagnano i rifiuti marini. Anche se le plastiche sono considerate materiali biochimicamente inerti (cioè, grazie alla loro struttura macromolecolare, non reagiscono con la membrana cellulare di un organismo, né la penetrano), tuttavia la maggior parte delle materie plastiche non sono pure. Infatti, esse, oltre alla loro struttura polimerica, sono costituiti da una varietà di sostanze chimiche che contribuiscono ad una determinata qualità delle materie plastiche [32; 33]. Infine, il *Marine Litter* e il *Beach Litter* possono provocare anche problemi economici e sociali. I milioni di tonnellate di plastica che ogni anno finiscono negli oceani del pianeta provocano oltre 13 miliardi di dollari l'anno di danni agli ecosistemi marini. In essi sono incluse anche le perdite economiche dei settori della pesca e del turismo, così come i costi di pulizia delle spiagge [37; 38].

2. Il *Marine Litter* in Italia e in Sardegna

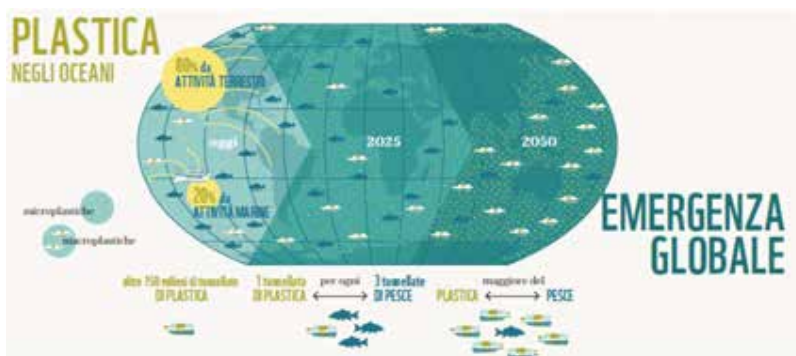
I mari italiani presentano quantità di plastica piuttosto importanti, come si vede nella Figura 4. I dati pubblicati all'interno del rapporto di Greenpeace (2017) [40] indicano che tra il 25÷30 % dei pesci e invertebrati analizzati nel Mar Tirreno, contengono micro-particelle di plastica. Una ricerca condotta su 7 località e 31 siti nel mare Ionio e Adriatico riporta come valore medio di rifiuti rinvenuti sulla spiaggia 0,67 elementi/m² [41].

Un ulteriore report del WWF [42], che si concentra sulla dispersione delle plastiche nelle coste e nei mari d'Italia, certifica che il 78 % di esse (41400 tonnellate) proviene dalle attività che insistono sulle aree costiere a causa di una gestione inefficiente dei rifiuti, l'intenso flusso turistico e le attività ricreative. Il 18 % (9500 tonnellate) proviene da pesca, acquacoltura e navigazione che disperdono nasse per crostacei, retine per molluschi, cassette per il trasporto del pesce. Il 4 % è trasportato dai fiumi italiani; il Po è, per esempio, responsabile del 3 % (1350 tonnellate) della plastica che ogni anno finisce nel mare e rappresenta la decima maggiore fonte d'inquinamento da plastica del Mediterraneo. In termini di Beach Litter, 12600 tonnellate della plastica dispersa dall'Italia nel Mediterraneo ritornano sulle nostre coste entro 1 anno, mentre un ulteriore 2 % arriva da attività costiere di altri paesi.

Al momento l'indagine più ampia disponibile svolta nelle spiagge italiane è quella di Legambiente [43]; questa fornisce dati relativi soprattutto alla macroplastica, certificando che il problema del Beach Litter è diffuso ed importante. Nelle 93 spiagge monitorate sono stati trovati in totale di 968 rifiuti ogni 100 metri lineari di spiaggia, di cui l'81 % rappresentato da materiali plastici (Fig. 5).

Per quanto riguarda la Sardegna negli ultimi anni si è iniziato a svolgere alcuni monitoraggi che hanno interessato solo poche spiagge. Per esempio, la letteratura disponibile ci permette di disporre di dati su alcune spiagge che insistono nel Golfo di Oristano (Sardegna centro occidentale); in esse sono state trovate concentrazioni di rifiuti con una media di 0,15 elementi/m² [44; 45].

filamenti di reti da pesca, con i lacci ad anello o gli imballaggi [34]. L'aumento numerico di microplastiche può intensificare la possibilità di mescolamento con fonti di cibo in superficie e può influire sulla capacità dei pesci che si nutrono di plancton e piccoli pesci di distinguere la plastica dal cibo naturale. I rifiuti di plastica vengono spesso scambiati per cibo dalla fauna marina, portando a complicazioni di salute e alla morte. L'ingestione di plastica è stata osservata in numerosi animali [35; 36].



Figura 4 - Mappa del Mediterraneo centro-occidentale che mostra l'ubicazione e la distribuzione di densità plastiche espresse in grammi di plastica per km². La dimensione dei cerchi è proporzionale ai valori di concentrazione misurati su una scala logaritmica. Particelle <700 µm e fibre sintetiche non sono state incluse nei calcoli di densità. Fonte: [39, p.4].

Figure 4 - Map of the central-western Mediterranean showing the location and distribution of plastic items expressed in grams of plastic per km². The size of the circles is proportional to the concentration values measured on a logarithmic scale. Particles <700 µm and synthetic fibers were not included in the density calculations. Source: [39, p.4].

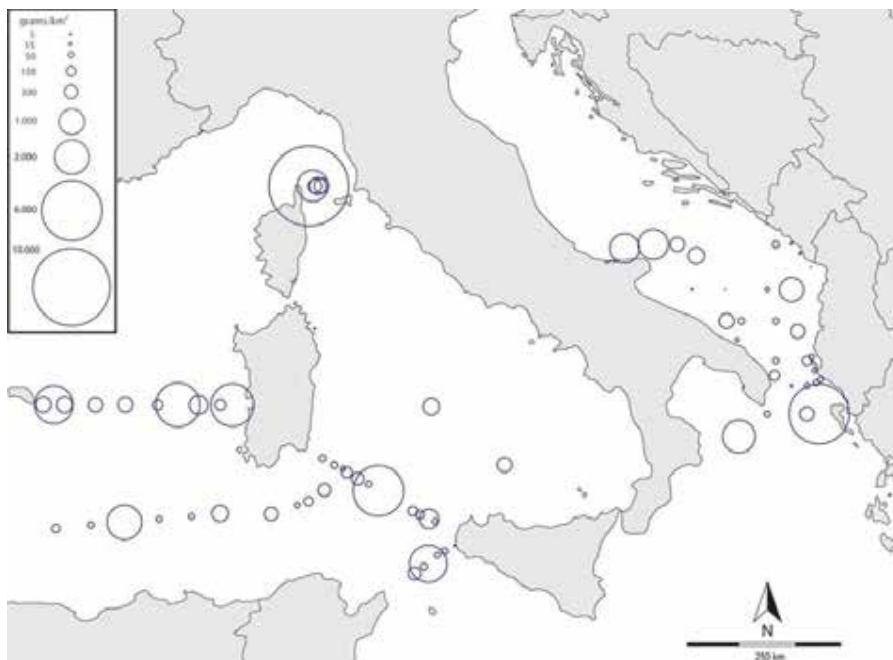

Figura 5 - Percentuale dei materiali più diffusi trovati nelle spiagge italiane. Fonte: [43, p. 18].

Figure 5 - Percentage of the top items observed along the Italian beaches. Source: [43, p. 18].

Anche lo studio di Camedda et al. [46] ha monitorato il Beach Litter di 7 spiagge (Alghero, Is Arenas, San Giovanni, Porto Pino, Poetto, Costa Rei e La Cinta) per un periodo di 4 anni (dal 2013 al 2016). L'analisi della variabilità è stata eseguita per rilevare qualsiasi

differenza di abbondanza e tipologia di rifiuti marini secondo il tempo, l'esposizione e il luogo. Delle 165 categorie riportate sul protocollo MSFD [47; 48], qui ne sono state registrate 146. Le classi di dimensioni più rappresentative del litter sono "macro" (17792 articoli; 44,51 %), seguite da "meso" (12414 articoli; 31,06 %) e "mega" (9766 articoli; 24,43 %). Dalle indagini condotte sulle spiagge sarde è emerso, inoltre, che i rifiuti erano presenti in tutti i siti, ma essi erano maggiormente concentrati sulle spiagge turistiche. È da sottolineare, inoltre, che la presenza di rifiuti provenienti da attività dell'industria della pesca è stata segnalata in tutti i siti campionati (anche se localizzati lontano dai porti turistici). Per la Sardegna è utile sottolineare, inoltre, che in letteratura pochissimi sono i lavori che riguardano le microplastiche.

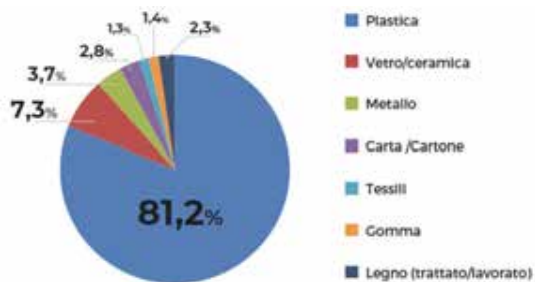
3. Area di Studio e obiettivi del lavoro

L'analisi della composizione dei rifiuti marini è importante in quanto fornisce informazioni sui rifiuti individuali e sulle relative fonti di ingresso e per capire i legami dinamici tra le fonti dei rifiuti e gli elementi naturali che ne influenzano la distribuzione e l'accumulo.

Lo studio presenta i risultati di un'indagine condotta su alcune spiagge dell'Asinara, Cala dei Ponzesi (o Cala Sabina) e nell'area di Punta Salippi nella spiaggia di Cala Spalmatore (Fig. 6), con la finalità di determinare una stima della presenza di rifiuti marini in un'area protetta e controllata. L'Isola è sede del Parco Nazionale dell'Asinara e dell'omonima Area Marina Protetta.



Figura 6 - Zonizzazione del Parco Nazionale dell'Asinara e dell'Area Marina Protetta con l'ubicazione delle aree indagate. Fonte: Ente Parco Nazionale dell'Asinara.

Figure 6 - Zones of the Asinara National Park and Marine Protected Area with the location of the survey areas. Source: Asinara National Park

4. Metodologia

Il monitoraggio nell'area oggetto di studio è iniziato nel 2017 con un campionamento su macro (>5 mm), meso (1÷5 mm) e micro (<1 mm) litter, ed è proseguito nel 2019 con uno stagionale condotto in primavera (marzo) e durante l'estate (luglio). I campionamenti sono stati eseguiti in differenti momenti dell'anno per monitorare le eventuali variazioni sulla quantità e composizione del Marine Litter dovute ai cambiamenti climatici e ai cambiamenti ambientali stagionali, o dovute al cambiamento nel flusso dei turisti tra bassa e alta stagione. Sebbene si raccomandino almeno altri due campionamenti in autunno e in inverno (come suggerito da UNEP/MAP, [48]), il presente lavoro si basa sull'analisi eseguita nel 2017 (dicembre) e

sui due campionamenti (marzo e a luglio) del 2019, numero minimo suggerito dalle linee guida DeFishGear. Il campionamento è stato eseguito secondo le linee guida operative per la valutazione rapida dei rifiuti da spiaggia descritte dall'UNEP [4; 49] e dal *Joint Research Centre* nell'ambito del *Marine Strategy Framework Directive* [48]; inoltre è stato usato anche il Protocollo del progetto internazionale di cooperazione DeFishGear, finanziato nell'ambito del programma europeo IPA Adriatico.

In ogni spiaggia è stata delimitata un'area con un transetto lungo 100 m in direzione parallela alla spiaggia, il quale è stato diviso a sua volta in aree di lunghezza pari a 10 m in modo da formare 10 "strisce" che sono state numerate da 1 a 10. L'altezza del transetto va da quella che viene definita la *strand line*, cioè la linea-limite di sabbia bagnata lasciata dall'alta marea, al retro della spiaggia, delimitata dall'inizio delle dune o dalla vegetazione. Di ogni transetto sono state rilevate le posizioni delle aree con un GPS per poter rilevare la stessa area, se possibile, nel successivo campionamento.

Per minimizzare il rischio di contaminazione è stato eseguito per primo il campionamento della microplastica più piccola (*Small Microplastic* o SMP, $20 \mu\text{m} \div 1 \text{ mm}$). Sono stati raccolti dei sedimenti (sempre entro i confini del transetto) in 5 aree vicino alla *strand line* e in 5 aree nella parte più alta del transetto. Ogni area era distante l'una dall'altra almeno 5 metri. Il materiale raccolto è stato messo all'interno di barattoli di vetro, uno per ogni area raccolta, che sono stati etichettati con il nome della spiaggia e la posizione all'interno del transetto, e successivamente spediti in laboratorio per le analisi.

Il campionamento delle microplastiche più grandi (*Large Microplastics* o LMP, $1 \div 5 \text{ mm}$) è stato eseguito in 5 aree accanto a quelle dove si sono campionate le *Small Microplastics* della parte bassa della spiaggia, o comunque nelle immediate vicinanze, e delle quali è stata rilevata la posizione tramite GPS. In queste aree è stato collocato un quadrato ($100 \text{ cm} \times 100 \text{ cm}$) metallico o in legno sulla superficie sabbiosa, e all'interno di esso sono stati prelevati i primi 3 cm di sedimento; la sabbia raccolta è stata quindi depositata in un *becker* di 2 litri in modo tale da calcolare il volume di sedimento campionato e passare il contenuto raccolto attraverso un setaccio con maglia di 1 mm. Questo *step* è stato ripetuto più volte fino a quando non si è campionata l'intera superficie del quadrato. Il materiale trattenuto dal setaccio è stato depositato, infine, in contenitori di vetro (etichettati con nome della spiaggia e tipo di plastica campionata) che sono stati trasferiti, infine, in laboratorio per la separazione delle microplastiche.

Questo protocollo di campionamento è stato usato anche per la raccolta della mesoplastica e del *Meso Litter* ($5 \div 25 \text{ mm}$), utilizzando un setaccio con maglia di 5 mm, per separare i detriti con dimensioni maggiori ai 5 mm dal sedimento di spiaggia.

Per quanto riguarda la macroplastica e i *Macro Litter* (macrorifiuti $< 25 \text{ mm}$), si è prima di tutto compilato il modulo di identificazione della spiaggia. Il campionamento è stato eseguito camminando metodicamente attraverso la spiaggia, ortogonalmente dalla linea di costa, all'interno delle 10 aree di 10 m di lunghezza in cui è stato diviso il transetto di 100 m (Fig. 7) e raccogliendo tutti i rifiuti solidi sulla superficie della spiaggia, anche parzialmente coperti dalla sabbia. Questi rifiuti sono stati collocati in sacchetti etichettati con il nome della spiaggia e numerati da 1 a 10 a seconda della striscia in cui sono stati campionati. Sono stati esclusi quelli non immediatamente rinvenibili e anche gli oggetti di dimensioni inferiori ai 25 mm. I rifiuti naturali e antropogenici di dimensioni superiori ai 50 cm sono stati fotografati, ne è stata rilevata la posizione con il GPS, e annotata la striscia di riferimento. Infine, i rifiuti raccolti sono stati identificati in laboratorio con la *List of*

Marine Litter per la catalogazione di *Macro Litter* e di *Meso Litter*.

Di seguito si è proceduto con la separazione e con l'analisi delle *Small Microplastic* e con la separazione in laboratorio delle *Large MicroPlastic* ($1 \div 5$ mm) e del *Mesolitter* ($5 \div 25$ mm). Dai sedimenti così separati e distribuiti su vassoi metallici, i frammenti plastici sono identificati mediante ispezione visiva (attuata con l'ausilio di una lente d'ingrandimento 4x) e separati per mezzo di pinzette metalliche. Successivamente ogni oggetto plastico appartenente alla classe del *Meso Litter* è stato categorizzato in accordo con la classificazione "*List of Marine Litters*" (Fig. 8).



Figura 7 - Schema della metodologia utilizzata per il campionamento.
Figure 7 - Sketch of the method used during the monitoring activities.

Code	Item name	Item counts	Total
ARTIFICIAL POLYMER MATERIALS			
G1	45-pack jokers, or pack rings		
G2	Shopping bags		
G4	Small plastic bags, e.g. freezer bags, including pieces		
G5	Plastic bag collection rule, what remains from rip-off plastic bags		
G7	Drink bottles <math>< 50 <td></td> <td></td>		
G8	Drink bottles >math> 50 <td></td> <td></td>		
G9	Cupper bottles & containers		
G10	Food containers and food food containers		
G11	Beach air inflated cosmetic bottles and containers, eg. Sunbaths		
G12	Other cosmetic bottles & containers		
G13	Other bottles & containers (drinks)		
G14	Engine of bottles & containers <math>< 50 <td></td> <td></td>		
G15	Engine of bottles & containers >math> 50 <td></td> <td></td>		
G16	Very rare square plastic containers, with handles		
G17	Injection gun containers		
G18	Cases and containers (buckets)		

Figura 8 - Schema estratto della *List of Marine Litter* con la quale sono stati categorizzati gli oggetti aventi dimensioni maggiori ai 25 mm e il *Meso Litter* ($1 \div 5$ mm).

Figure 8 - Extract from the *List of Marine Litter* used to categorize objects with dimension greater than 25 mm and *Meso Litter* ($1 \div 5$ mm).

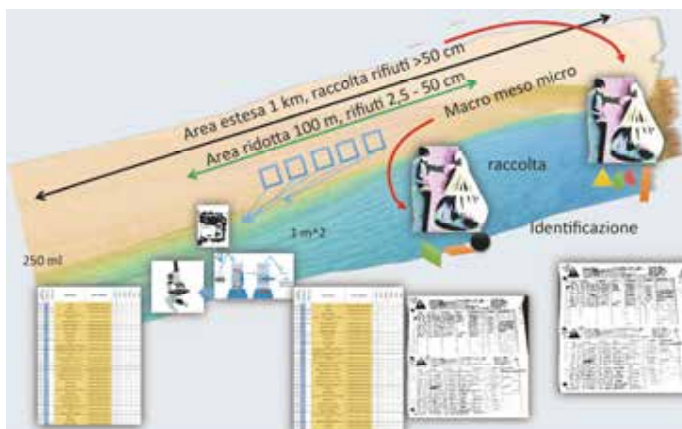
Gli oggetti plastici appartenenti alla classe delle *Large Microplastics*, una volta separati, sono stati classificati in termini di tipologia e colore (Tab. 1 e Tab. 2,) e ne sono state

determinate le dimensioni massime utilizzando un calibro di precisione (per oggetti di forma irregolare si è assunta come dimensione caratteristica quella identificata dalla diagonale maggiore). Di seguito vengono riportati alcuni esempi di *Large Microplastics* rilevati come *Filaments* < 5 mm (G113) (vedi Fig. 9) e *Foams* < 5 mm (G115, G117) (vedi Fig. 10).

Tabella 1 - Categorie di *micro litter*.

Table 1 - Categories of *micro litter* Items.

<i>Fragments (Frammenti)</i> G103, G104, G105, G106
<i>Pellets</i> G107, G108, G109, G110, G111
<i>Granules (Granuli)</i> G116
<i>Filaments (Filamenti)</i> G113
<i>Films</i> G114
<i>Foam</i> G115, G117
<i>Other (materiale non plastico)</i> G217
<i>Uncategorized plastic pieces*</i>

Tabella 2 - Colore degli oggetti in plastica.

Table 2 - Colour of plastic items.

<i>White</i> (bianco)
<i>Clear-white-cream</i> (crema)
<i>Red</i> (rosso)
<i>Orange</i> (arancione)
<i>Blue</i> (blu)
<i>Black</i> (nero)
<i>Grey</i> (grigio)
<i>Brown</i> (marrone)
<i>Green</i> (verde)
<i>Pink</i> (rosa)
<i>Tan</i> (marrone chiaro)
<i>Yellow</i> (giallo)



Figura 9 - Esempio di Filamenti ritrovati.

Figure 9 - Examples of fibers.



Figura 10 - Esempio di Foam ritrovati.

Figure 10 - Examples of foam.

Per la registrazione dei macrorifiuti, si è utilizzato per ogni sacco raccolto il modulo di catalogazione del *Beach Litter* (“*BEACH LITTER SAMPLING FORM*” (100 m)

nel quale è stato indicato il nome della spiaggia, il numero della “striscia” dalla quale provengono i rifiuti, la data del campionamento e, infine, descritti i rifiuti indicandone il codice della tipologia, la quantità trovata, la categoria e eventuali osservazioni.

5. Risultati e Discussione del monitoraggio nelle spiagge campionate nell’isola dell’Asinara

Macroplastica

Nel 2017 sono stati raccolti 1971 elementi sulle due insenature di Cala dei Ponzesi (o Cala Sabina); la densità media dei rifiuti individuata in questo campionamento è di 1,9 elementi/m². Nel campionamento del 2019, nell’intero periodo di monitoraggio, sono stati raccolti nel sito di Cala dei Ponzesi un totale di 816 rifiuti, per un peso complessivo di 1942 g con una media pari a 0,81 elementi/m². Nel sito di Cala Spalmatore, invece, sono stati rinvenuti 289 rifiuti, per un peso complessivo di 2906 g e un valore medio di 0,21 elementi/m².

Le abbondanze di macroplastica tra i periodi di campionamento investigati sono risultate altamente variabili: il numero di elementi raccolti sulle spiagge di Cala dei Ponzesi nell’inverno del 2017 risulta 4 volte superiore all’ultimo campionamento del 2019. Inoltre, l’analisi diversificata dei monitoraggi svolti a marzo e a luglio registra una crescita di rifiuti dalla stagione primaverile a quella estiva. L’incremento nel 2019 dalla primavera all’estate è stato per Cala Sabina e Cala Spalmatore rispettivamente del 27 % e del 39 % (Fig. 11).

I risultati della percentuale di rifiuti totali rinvenuti in ogni campagna e per ogni categoria (vetro/ceramica, metallo, legno, carta, tessuto, gomma, polimeri artificiali) sono



Figura 11 - I rifiuti rinvenuti nelle spiagge di Cala Sabina e Cala Spalmatore nelle diverse campagne di rilevamento per categoria (vetro/ceramica, metallo, legno, carta, tessuto, gomma, polimeri artificiali). M indica il monitoraggio eseguito a marzo '19, L quello eseguito a luglio '19.
 Figure 11 - Litter collected on the beaches of Cala Sabina and Cala Spalmatore during the three surveys represented by category (glass/ceramic, metal, wood, paper, fabric, rubber, artificial polymers). M indicates the monitoring performed in March '19 and L in July '19.

rappresentati in Tabella 3. La categoria dei polimeri artificiali, quindi degli oggetti e dei frammenti di plastica, è quella maggiormente presente. Tra le diverse categorie di rifiuto nelle aree di campionamento si mantengono proporzioni più o meno simili, con l'eccezione di una preponderante prevalenza di materiale polimerico che varia dal 75 % a 96 % a seconda del sito campionato e della stagione in cui è stato effettuato il campionamento.

Nella Tabella 3 sono state selezionate le 20 tipologie di materiale polimerico più abbondanti con la relativa percentuale di elementi, mentre nella Figura 12 viene illustrata la suddivisione delle 20 principali categorie di rifiuti in plastica trovata nelle spiagge durante i tre diversi momenti di campionamento. I frammenti di plastica con dimensione compresa tra 2,5 e 50 cm rappresentano quasi il 25 % del totale dei rifiuti di plastica rinvenuti, seguiti dal 18 % costituito da frammenti di plastica di dimensione inferiore ai 2,5 cm.

Osservando nel dettaglio la suddivisione della categoria di materiale polimerico per sito di campionamento in Figura 12, si nota la presenza preponderante di frammenti di plastica di dimensioni comprese tra 2,5 e 50 cm e tra 0 e 2,5 cm (G78 e G79).

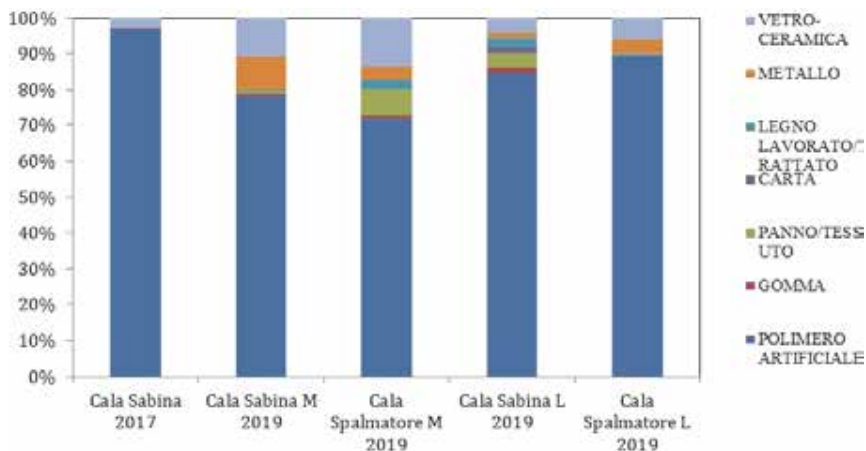
Nel caso dell'ultimo rilievo (luglio 2019) in Cala Spalmatore, i frammenti di plastica rappresentano l'80 % di rifiuti collezionati. Le altre classi di rifiuti sono presenti in percentuali molto ridotte, inferiore al 6 %. Due classi la cui presenza è abbastanza consistente sono la G4, che comprende sacchetti di plastica e la G31, che rappresenta bastoncini. L'abbondanza di frammenti potrebbe far pensare ad una loro possibile origine dovuta a frammentazione di oggetti in plastica di più grandi dimensioni come ipotizzato anche da Isobe et al. [50]. Così come i frammenti di buste di plastica potrebbero indicare una disgregazione di oggetti più grandi.

Tabella 3 - Percentuale delle 20 principali classi della categoria dei polimeri artificiali (protocollo DeFishGear) calcolata sul numero totale di rifiuti di plastica rinvenuti in tutte le spiagge oggetto di indagine.

Table 3 - Percentage of the 20 main classes of the artificial polymers category (DeFishGear protocol) calculated on the total number of plastic waste found in all the beaches surveyed.

Codice delle categorie	Categoria di rifiuto	Percentuale nei campioni osservati
G3	Buste della spesa	0,9
G4	Piccoli sacchetti di plastica, ad es. sacchetti per congelatore	2,8
G9	Bottiglie e contenitori più puliti	1,2
G19	Ricambi auto	1,3
G21	Bevande in plastica per coperchi / coperchi	0,8
G22	Tappi / coperchi in plastica prodotti chimici, detergenti	1,1
G23	Cappucci / coperchi in plastica non identificati	4,7
G24	Anelli di plastica da tappi di bottiglia / coperchi	1,7
G31	Bastoncini di lecca-lecca	5,8
G32	Giocattoli e petardi	3,3
G49	Corda (diametro superiore a 1 cm)	2,1
G50	Corda e cavo (diametro inferiore a 1 cm)	3,4
G54	Reti e pezzi di rete > 50 cm	0,4
G75	Pezzi di plastica / polistirolo 0 ÷ 2,5 cm	1,5
G76	Pezzi di plastica / polistirolo 2,5 ÷ 50 cm	4,1
G77	Pezzi di plastica / polistirolo > 50 cm	5,9
G78	Pezzi di plastica 0 ÷ 2,5 cm	18,0
G79	Pezzi di plastica 2,5 ÷ 50 cm	24,7
G80	Pezzi di plastica > 50 cm	5,2
G81	Pezzi di polistirolo 0 ÷ 2,5 cm	0,2

In Figura 13 vengono mostrati alcuni dei campioni di rifiuti rinvenuti durante la fase di conteggio e di classificazione in laboratorio.



Figura 12 - Suddivisione delle 20 principali categorie di rifiuti in plastica trovata nelle spiagge durante i due diversi momenti di campionamento. La tipologia di rifiuto è indicata utilizzando il codice delle categorie presente nel protocollo DeFishGear. La lista dei rifiuti corrispondenti ad ogni codice è presente nella Tabella 3.

Figure 12 - Subdivision of the 20 main categories of plastic waste collected in the beaches during the two surveys. The type of waste is indicated using the category code presented in the DeFishGear protocol. The list of waste corresponding to each code is reported in Table 3.

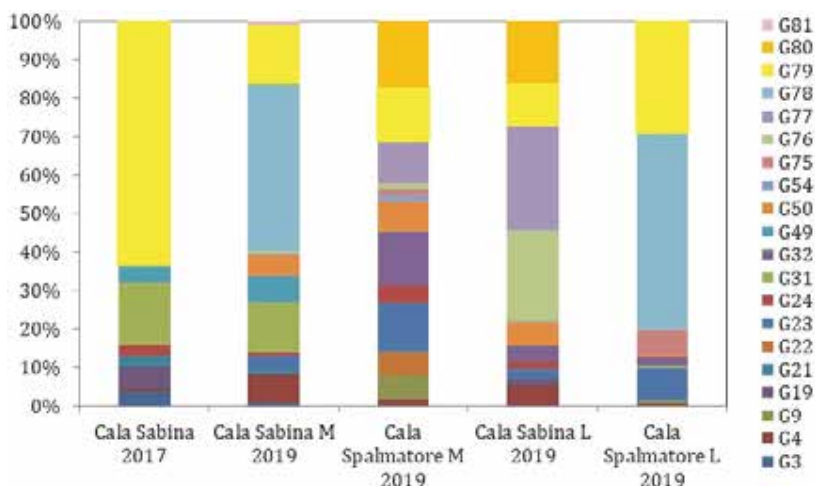

Figura 13 - Caratterizzazione dei rifiuti marini effettuata utilizzando la lista delle categorie del protocollo proposto da Defishgear.

Figure 13 - Characterization of marine litter using the list reported in the protocol proposed by Defishgear.

Mesoplastica e microplastica

Un totale di 165 elementi (di cui 12 pellet e 153 frammenti di plastica e vetro) appartenenti alla categoria delle mesoplastiche sono stati isolati nelle cinque campagne condotte sulle spiagge dell'Asinara, con un peso complessivo di 14,7 g. I risultati mostrano un *trend* simile per entrambi i siti analizzati con un incremento del numero di elementi durante la primavera del 2019. I frammenti sono la forma più comune, e la classe più abbondante compresa ha una dimensione tra 0,5 e 1 mm. Per le mesoplastiche riscontriamo una variazione stagionale confrontabile con altri studi condotti nel Mediterraneo [51]. Infatti, variazioni stagionali nell'abbondanza delle plastiche sono già state studiate nel Mar Mediterraneo anche da Collignon et al. [44], in questo studio sono state mostrate concentrazioni molto basse nei mesi invernali e un incremento nei mesi primaverili presi in considerazione anche in questo studio.

Per quanto concerne le microplastiche, le elaborazioni dei dati disponibili sono riferite, al momento, soltanto al campionamento di dicembre 2017; i dati relativi ai campionamenti del 2019 sono ancora in fase di analisi ed elaborazione.

I primi dati indicano che sono state trovate 269 microplastiche (SMP) nel solo sito di Cala dei Ponzesi relative al 2017 con una stima di 0,26 elementi/m². La tipologia dominante sono le fibre (più del 98 %). Come si può osservare dal grafico (Fig. 14) il 90,7 % è dato da fibre di colore blu e azzurro. Alcune immagini delle fibre trovate sono riportate nelle Figura 15a, 15b e 15c.



Figura 14 - Proporzione dell'abbondanza totale di particelle di plastica osservate allo stereomicroscopio presenti nelle sabbie nel sito di Cala dei Ponzesi o Cala Sabina.

Figure 14 - Proportion of the total abundance of microplastic observed with the stereomicroscope present in the sands collected at Cala dei Ponzesi (or Cala Sabina).

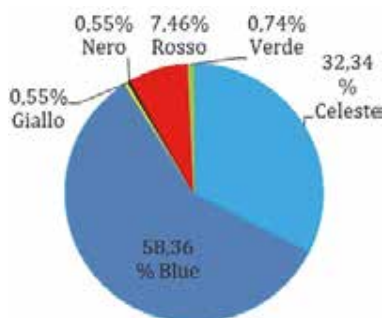

Figura 15 - Immagini di fibre microplastiche osservate allo stereomicroscopio con ingrandimento 80x.

Figure 15 - Images of microplastic fibers observed with a stereo microscope (80x).

6. Conclusioni

Dai primi risultati dei campionamenti effettuati nell'isola dell'Asinara, per valutare la presenza della macro e microplastica, risulta evidente come l'adozione di un piano di monitoraggio durante l'anno abbia permesso di considerare alcune variazioni relative alla stagionalità. I risultati, infatti, hanno mostrato una distribuzione eterogenea tra le diverse campagne. Le diverse tipologie di *Marine Litter* descritte in questo lavoro evidenziano un *trend* inverso nella presenza di macro e mesoplastiche: le macroplastiche subiscono un aumento nei mesi estivi mentre le mesoplastiche durante i mesi primaverili.

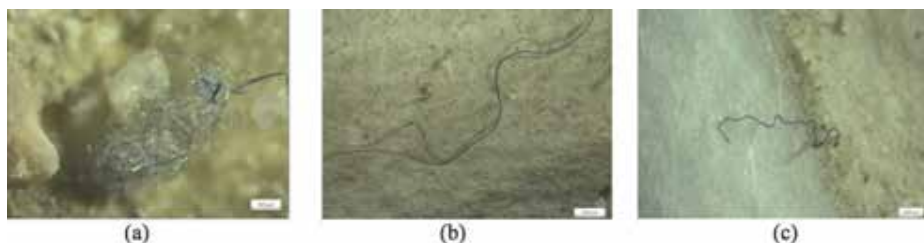
Per quanto riguarda le macroplastiche, dal 2017 (1,9 elementi/m²) al 2019 (0,8 elementi/m²), esse subiscono un'importante diminuzione, probabile segnale degli interventi di sensibilizzazione condotti negli ultimi anni da media ed enti nazionali. La densità di rifiuti resta in ogni caso abbastanza alta se si considera che studi sulle coste del Mare Adriatico e del Mar Ionio hanno riportato una densità di 0,67 elementi/m² [41].

Ciò è interessante perché l'accumulo diretto di rifiuti nelle coste è spesso correlato alla densità abitativa di una regione geografica [8; 52], o all'intenso sfruttamento turistico delle spiagge. Le spiagge analizzate in questo lavoro fanno parte del Parco Nazionale dell'Asinara che non è abitato stabilmente e ha un flusso di turisti medio, inoltre fa parte di una regione, la Sardegna, con una densità abitativa poco elevata. Perciò la densità media di rifiuti rilevata in questo studio (soprattutto macroplastiche e mesoplastiche), in linea con precedenti studi in altre zone della Sardegna [45; 46], porta a supporre che il *Beach Litter* possa essere arrivato soprattutto da fonti lontane, trasportato dal vento e dalle correnti marine.

La presenza dei rifiuti su una spiaggia è, infatti, la conseguenza di una serie di fattori e condizionamenti che possono essere interpretati dall'attenta analisi del singolo oggetto e dal suo stesso indice di conservazione. Tuttavia, una serie di elementi subentra a determinare il suo accumulo e la differenza di distribuzione la quale è legata ad una serie di fattori fisici condizionati a loro volta da processi esogeni in atto in quella particolare condizione geografica e, non secondariamente, da fattori geomorfologici che ne condizionano profondamente il suo trasporto e la sua sedimentazione. Appare evidente dalla situazione che si può osservare nel promontorio di Punta Sabina, dove le spiagge sono situate in posizioni opposte e la granulometria delle insenature si rivela profondamente diversa; in questo breve tratto di costa si condensano i possibili risultati della dinamica del mare associata alle condizioni geomorfologiche dei luoghi. Mentre la spiaggia campionata di Cala dei Ponzesi, nota anche come Cala Sabina, è soggetta all'influenza del moto ondoso proveniente da sud, la seconda, Cala del Turco (al momento non rilevata), invece, risente del moto ondoso proveniente dai quadranti nord, quelli decisamente più efficaci; se la prima mostra una fascia sabbiosa con residui di un limitato campo dunare, la seconda è caratterizzata da una sabbia ghiaiosa e ciottolosa mentre la parte sabbiosa è oramai prevalentemente nella spiaggia sommersa.

La varietà di materiale antropico proveniente dal mare è soprattutto condizionata dal moto ondoso per gli oggetti che hanno elevata capacità di galleggiamento, mentre quelli in sospensione o al limite della superficie sono spesso trascinati dalle correnti di deriva.

Il ruolo del vento diventa sempre più determinante nel trasporto del materiale anche di dimensioni considerevoli verso l'interno, dove talora si accumula in trappole morfologiche dalle quali necessita di una energia eolica sempre maggiore per poter superare lo sbarramento morfologico. In alcuni casi, soprattutto con il materiale plastico di dimensioni importanti (bidoni, recipienti, forme a stampo, ecc.) si formano accumuli a distanza notevole

dalla linea di costa; ciò non deve stupire poiché i venti del IV Quadrante possono superare frequentemente i 100/km orari anche in situazioni apparentemente riparate come la costa orientale dell'Asinara, dove, risiedono queste due spiagge.

La condizione della seconda spiaggia analizzata, quella di Cala Spalmatore nell'area di Punta Salippi, invece, appare differente e il materiale rilevato ed analizzato lo dimostra chiaramente; anche questa situazione deve essere considerata nel profondo cambiamento delle condizioni morfoclimatiche che possiedono un minore effetto rispetto ai flussi di deriva che interessano questa parte dell'isola, essa è ubicata, infatti, lungo i canali di ingresso ed uscita delle acque provenienti da occidente, dal quel mare che i locali conoscono come "il mare di fuori" riferendosi alle acque del Mar di Sardegna i cui fondali si immergono rapidamente verso le zone di piattaforma profonda, contrariamente al Golfo dell'Asinara dove l'indice di pendenza della spiaggia sommersa è molto basso, pari a solo pochi gradi.

Il passaggio continuo di queste correnti determina lo spostamento del materiale lungo costa favorendo l'eventuale trasporto di oggetti per erosione diretta della costa sarda. Questa situazione è ancora più evidente nei giorni successivi ad un grande evento alluvionale, quando, nelle spiagge del canale dell'Asinara vengono depositati e sedimentati molti materiali organici, in cui sovrabbondano i resti dei canneti erosi dalle piene fluviali. Per avere un quadro più completo della situazione occorre, tuttavia effettuare campionamenti almeno nelle diverse stagioni dell'anno e a seguire di eventi singolari come subito dopo una mareggiata.

L'analisi dei dati evidenzia che l'abbondanza di rifiuti marini appartenenti alla categoria dei materiali polimerici è in ogni sito maggiore del 75 %. Osservando nel dettaglio le 20 tipologie di rifiuto polimerico maggiormente rinvenuto, si nota che oltre ai frammenti di varie dimensioni (inferiori o maggiori di 2,5 cm), le macroplastiche più frequentemente raccolte sono state

- tappi di bottiglie;
- tappi non identificati;
- cerchietti delle bottiglie;
- pezzi di buste;
- bastoncini.

Questo dimostra, come confermano molti altri studi, che la plastica è il più diffuso e abbondante rifiuto presente in ambiente marino. E ciò evidenzia la necessità di riconoscere il fatto che i rifiuti marini non sono semplicemente un problema di gestione dei rifiuti. Una delle cause principali dell'accumulo di rifiuti a terra è l'uso di prodotti a breve durata, monouso. A questo proposito, la strategia dell'UE sulla plastica recentemente adottata dovrebbe portare ad una drastica riduzione dell'uso e dell'impatto degli articoli in plastica monouso sulle spiagge.

Nel complesso, l'eterogeneità spaziale trovata in questo studio potrebbe essere dovuta a molteplici fattori che hanno influenzato la distribuzione di particelle di plastica sulle spiagge indagate. Questo lavoro sottolinea l'importanza del monitoraggio del *Marine Litter* sulle spiagge e l'esigenza di utilizzare un piano di campionamento standardizzato per comprendere meglio il trasporto e l'identificazione delle possibili fonti di microplastiche.

Bibliografia

- [1] UNEP, 2009, *Marine litter: a global challenge. Prepared by Jęftic, Ljubomir, Sheavly, Seba, and Adler, Ellik*, edited by Meith-Nikki, Nairobi.

- [2] UNEP & NOAA, 2011, *The Honolulu strategy: a global framework for prevention and management of marine debris*. The United Nations Environment Program (UNEP), Nairobi, Kenya, and National Oceanic and Atmospheric Administration (NOAA) Marine Debris Program, Silver Spring, Maryland, USA.
- [3] Jambeck J.R., Geyer R., Wilcox C., Siegler T.R., Perryman M., Andrady A., Narayan R. & Law K.L., 2015, *Plastic waste inputs from land into the ocean*, in *Science*, 347(6223), 768-771.
- [4] Cheshire A.C., Adler E., Barbière J., Cohen Y., Evans S., Jarayabhand S., Jeftic L., Jung R.T., Kinsey S., Kusui E.T., Lavine I., Manyara P., Oosterbaan L., Pereira M.A., Sheavly S., Tkalin A., Varadarajan S., Wenneker B. & Westphalen G., 2009, *UNEP/IOC Guidelines on survey and monitoring of marine litter*, UNEP Regional Seas Reports and Studies, 186. IOC, Technical Series n. 83.
- [5] UNEP/MAP, 2016a, *Marine plastic debris and microplastics – Global lessons and research to inspire action and guide policy change*, United Nations Environment Programme, Nairobi.
- [6] Galgani F., Hanke G., Werner S. & De Vrees L., 2013a, *Marine litter within the European marine strategy framework directive*, *ICES J. Mar. Sci.*, 70, 1055-1064.
- [7] UNEP, 2019, *Legal Limits on Single-Use Plastics and Microplastics: A Global Review of National Laws and Regulations* (a cura di Excell C., Salcedo-La Viña C., Worker J., Moses E.), United Nations Environment Programme, Nairobi, Kenya.
- [8] Galgani F., Hanke G. & Maes T., 2015, *Global Distribution, Composition and Abundance of Marine Litter, Marine Anthropogenic Litter* (a cura di Bergmann M., Gutow L., Klages M.), Springer, Londra, UK, 29-56.
- [9] Vlachogianni T., Anastasopoulou A., Fortibuoni T., Ronchi F. & Zeri C., 2017, *Marine Litter Assessment in the Adriatic and Ionian Seas*, IPA-Adriatic DeFishGear Project, MIO-ECSDE, HCMR e ISPRA.
- [10] Critchell K., Grech, A. Schlaefel J., Andutta F.P., Lambrechts J., Wolanski E., Hamann M., 2015, *Modelling the fate of marine debris along a complex shoreline: lessons from the great barrier reef*, *Estuarine Coastal and Shelf Science*, 167, 414-426.
- [11] Prevenios M., Zeri C., Tsangaris C., Liubartseva S., Fakiris E. & Papatheodorou G., 2018, *Beach litter dynamics on Mediterranean coasts: Distinguishing sources and pathways*, *Marine Pollution Bulletin*, 129, 448-457.
- [12] Pham C.K., Ramirez-Llodra E., Alt C.H., Amaro T., Bergmann, M., Canals M., Davies J., Duineveld G., Galgani F., Howell K.L., Veerle A. I. Huvenne, Isidro E., Jones D.O.B., Lastras G., Morato T., Nuno Gomes-Pereira J., Purser A., Stewart H., Tojeira I., Tubau X., Van Rooij D. & Tyler P.A., 2014, *Marine litter distribution and density in european seas, from the shelves to deep basins*, in *PloS ONE*, 9 (4), e95839.
- [13] Leggett C., Scherer N., Curry M. & Bailey R., 2014, *Assessing the Economic Benefits of Reductions in Marine Debris: A Pilot Study of Beach Recreation in Orange County, California. Final Report: June 15 2014*, National Oceanic and Atmospheric Administration, Cambridge, USA.
- [14] Williams A.T., Rangel-Buitrago N.G., Anfuso G., Cervantes O. & Botero C.M., 2016, *Litter impacts on scenery and tourism on the Colombian north Caribbean coast*, *Tourism Management*, 55, 209-224.
- [15] Brouwer R., Hadzhiyska D., Ioakeimidis C. & Ouderdorp H., 2017, *The social costs of marine litter along European coasts*, *Ocean & Coastal Management*, 138, 38-49.

- [16] Krelling A.P., Williams A.T. & Turra A., 2017, *Differences in perception and reaction of tourist groups to beach marine debris that can influence a loss of tourism revenue in coastal areas*, in *Marine Policy*, 85, 87-99.
- [17] Asensio-Montesinos F., Anfuso G. & Corbí H., 2019, *Coastal scenery and litter impacts at Alicante (SE Spain): management issues*, in *Journal of Coastal Conservation*, 23 (1), 185-201.
- [18] UN Environment, 2017, *Marine Litter Socio Economic Study*, United Nations Environment Programme, Nairobi, Kenya.
- [19] Thevenon F., Carroll C. & Sousa J. (a cura di), 2014, *Plastic Debris in the Ocean: The Characterization of Marine Plastics and their Environmental Impacts*, Situation Analysis Report, IUCN, Gland, Svizzera.
- [20] www.europarl.europa.eu/news/it/headlines/society/20181005STO15110/plastica-negli-oceani-i-fatti-le-conseguenze-e-le-nuove-norme-infografica
- [21] Alessi E. & Di Carlo G., 2018, *Out of the plastic trap: saving the Mediterranean from plastic pollution*, Report del WWF Mediterranean Marine Initiative, Roma
- [22] Andrady A.L., 2011, *Microplastics in the marine environment*, *Marine Pollution Bulletin*, 62 (8), 1596-1605.
- [23] European Commission, 2018, *A European Strategy for Plastic in a Circular Economy*. eur-lex.europa.eu/legal-content/IT/TXT/HTML/?uri=CELEX:52018DC0028&from=EN
- [24] Eunomia: <https://www.eunomia.co.uk/reports-tools/plastics-in-the-marine-environment/>
- [25] Boucher J. & Friot D., 2017, *Primary Microplastics in the Oceans: Global Evaluation of Sources*, Gland, Svizzera, IUCN.
- [26] UN Environment, 2018, *Mapping of Global Plastics Value Chain and Plastics Losses to the Environment (With a Particular Focus on Marine Environment)* (Wyberg M., Laurent A., Hauschild M. Eds.), United Nations Environment Programme, Nairobi, Kenya.
- [27] Boucher J. & Friot D., 2019, *The challenges of measuring plastic pollution*, in *Field Actions Science Reports*, Special Issue 19, 68-75.
- [28] Marilisco, 2013, *Rifiuti solidi in mare (Marine Litter): problemi e possibili soluzioni* (a cura di Alcaro L.). [www.marlisco.eu/tl_files/marlisco/Video-Contest/Downloads/Rifiuti Solidi In Mare.pdf](http://www.marlisco.eu/tl_files/marlisco/Video-Contest/Downloads/Rifiuti_Solidi_In_Mare.pdf)
- [29] Geyer R., Jambeck J. R. & Lavender Law K.L., 2017, *Production, use, and fate of all plastics ever made*, in *Science Advances*, 3 (7), e1700782.
- [30] Law K.L., 2017, *Plastics in the Marine Environment*, *Annual Reviews Marine Science*, 9, 205-229.
- [31] Gall S.C. & Thompson R.C., 2015, *The impact of debris on marine life*, in *Marine Pollution Bulletin*, 92 (1-2), 170-179.
- [32] Al-Malaika S., Axtell F., Rothern R. & Gilbert M., 2017, *Additives for Plastics*, in *Brydson's Plastics Materials* (a cura di Gilbert M.), Elsevier, Butterworth-Heinemann, Oxford, UK, pp. 127-168.
- [33] Verma V., Vinoda K.S., Papireddy M. & Gowda A.N.S., 2016, *Toxic Pollutants from Plastic Waste- A Review*, *Procedia Environmental Sciences*, 35, 701-708.
- [34] Consoli P., Romeo T., Angiolillo M., Canese S., Esposito V., Salvati E., Scotti G., Andaloro F. & Tunesi L., 2019, *Marine litter from fishery activities in the Western Mediterranean sea: The impact of entanglement on marine animal forests*, *Environmental Pollution*, 249, 472-481.

- [35] Sharma S. & Chatterjee S., 2017, *Microplastic pollution, a threat to marine ecosystem and human health: a short review*, Environmental Science and Pollution Research., 24, 21530-21547.
- [36] Wilcox C., van Sebille E. & Hardesty B.D., 2015, *Threat of plastic pollution to seabirds is global, pervasive, and increasing*, Proceedings of the National Academy of Sciences of the United States of America, 112 (38), 11899-11904.
- [37] Arcadis, 2014, *Marine Litter study to support the establishment of an initial quantitative headline reduction target - SFRA0025*, European Commission DG Environment, Project number BE0113.000668, Final Report.
- [38] Millet H., Vangheluwe P., Block C., Sevenster A., Garcia L. & Antonopoulos R., 2019, *The Nature of Plastics and Their Societal Usage*, Plastic and Environment (a cura di Harrison R.M., Hester R.E.), Royal Society of Chemistry, Londra, UK, 1-20.
- [39] Suaria G., Avio C.G., Mineo A., Lattin G.L., Magaldi M.G., Belmonte G., Moore C.J., Regoli F. & Aliani S., 2016, *The Mediterranean Plastic Soup: synthetic polymers in Mediterranean surface waters*, in Scientific Reports, 6 (37551).
- [40] Greenpeace, 2017, *Un Mediterraneo pieno di plastica. Ricerca sull'inquinamento marino derivante dalla plastica, impatti e soluzioni*. storage.googleapis.com/planet4-italy-stateless/2018/11/b3feaa17-b3feaa17-un_mediterraneo_pieno_di_plastica.pdf
- [41] Vlachogianni T., Fortibuoni T., Ronchi F., Zeri C., Mazziotti C., Tutman P., Bojanić Varezić D., Palatinus A., Trdan Š., Peterlin M., Mandić M., Markovic O., Prvan M. Kaberi H., Prevenios M., Kolitari J., Kroqi G., Fusco M., Scoullou M., 2018, *Marine litter on the beaches of the Adriatic and Ionian Seas: An assessment of their abundance, composition and sources*, Marine Pollution Bulletin, 131, Part A, 745-756.
- [42] Alessi E., 2019, *Fermiamo L'inquinamento da Plastica. Italia: una Guida Pratica per Uscire dalla Crisi della Plastica*, Report del WWF Mediterranean Marine Initiative, Roma.
- [43] Legambiente, 2019, *Beach litter: Indagine sui rifiuti nelle spiagge italiane* (a cura di Carpentieri S., Colombo L., Di Vito S., Grasso P., Merlo V., Scocchera E.). www.legambiente.it/wp-content/uploads/dossier_beachlitter2019.pdf
- [44] Collignon A., Hecq J.H., Jousseau M. & Goffart A., 2014, *Annual variation in neustonic micro- and meso-plastic particles and zooplankton in the Bay of Calvi (Mediterranean-Corsica)*, Marine Pollution Bulletin, 79 (1-2), 293-298.
- [45] de Lucia G.A., Caliani I., Marra S., Camedda A., Coppa S., Alcaro L., Campani T., Giannetti M., Coppola D., Cicero A.M., Panti C., Baini M., Guerranti C, Marsili L., Massaro G., Fossi M.C. & Matiddi M., 2014, *Amount and distribution of neustonic micro-plastic off the western Sardinian coast (Central-Western Mediterranean Sea)*, Marine Environmental Research, 100, 10-16.
- [46] Camedda A., Coppa S., Palazzo L., Marra S., Massaro G., Brundu R. & De Lucia G.A., 2017, *First characterization and impact assessment of beach litter in Sardinia (Western Mediterranean)*, 15th International Conference on Environmental Science and Technology, Rodi, Grecia.
- [47] OSPAR, 2010, *Guideline for Monitoring Marine Litter on the Beaches in the OSPAR Maritime Area*, Report www.ospar.org/ospar-data/10-02e_beachlitter%20guideline_english%20only.pdf
- [48] Galgani F., Hanke G., Werner S., Oosterbaan L., Nilsson P., Fleet D., Kinsey S., Thompson R.C., van Franeker J., Vlachogianni T., Scoullou M., Mira Veiga J.,

- Palatinus A., Matiddi M., Maes T., Korpinen S., Budziak A., Leslie H., Gago J. & Liebezeit G., 2013, *Monitoring Guidance for Marine Litter in European Seas*, MSFD GES Technical Subgroup on Marine Litter (TSG-ML). DRAFT REPORT, European Commission.
- [49] UNEP/MAP, 2016, *Integrated Monitoring and Assessment Programme of the Mediterranean Sea and Coast and Related Assessment Criteria*, UNEP/MAP, Athens, Greece.
- [50] Isobe A., Kubo K., Tamura Y., Kako S., Nakashima E. & Fujii N., 2014, *Selective transport of microplastics and mesoplastics by drifting in coastal waters*, in *Marine Pollution Bulletin*, 89, 324-330.
- [51] Bains M., Fossi M., Galli M., Caliani I., Campani T., Finoia M. & Panti C., 2018, *Abundance and characterization of microplastics in the coastal waters of Tuscany (Italy): The application of the MSFD monitoring protocol in the Mediterranean Sea*, *Marine Pollution Bulletin*, 133, 543-552.
- [52] Liubartseva S., Coppini G., Lecci R. & Creti S., 2016, *Regional approach to modeling the transport of floating plastic debris in the Adriatic Sea*, *Marine Pollution Bulletin*, 103 (1-2), 115-127.

Benché il lavoro sia frutto di una riflessione comune, si ritiene di dover attribuire a M. Contini e A. Lazarou il punto 1, a V. Gazale e U. Simeoni il punto 2, a D. Carboni, C. Corbau e V. Gazale il punto 3, a D. Carboni, C. Corbau e U. Simeoni il punto 4; a D. Carboni e C. Corbau il punto 5, il punto 6 è comune a tutti gli autori.

MONITORING ONLINE PERCEPTION OF ENVIRONMENTAL ISSUES ON COASTS OF SICILY

Damiano De Marchi¹, Mirko Lalli¹, Alessandro Mancini¹

¹ The Data Appeal Company - Travel Appeal, via Ippolito Pindemonte 63 - 50124, Florence (Italy), phone +39 345 156 3011, e-mail: damiano.demarchi@datappeal.io

Abstract – The analysis of big data on human experience (reviews, comments, ratings, etc.) can provide valuable insights to companies and institutions about market intelligence, since they have significant impact on consumers' purchase decisions. But there are other fields of applications. This pioneer study applied the artificial intelligence proprietary tools of The Data Appeal Company for a different aim: monitoring the online perception of environmental issues on 88 beaches of Sicily. Results proved that it is possible to monitor environmental situation even to sites where there are no other kind of monitoring, using as bases the free and available contents posted by humans online, processed and analyzed by artificial intelligence.

Introduction

The development of Social Media Companies and Web 2.0 in early 2000s has encouraged people to express their opinions about products/services. As e-commerce continued evolving, many online enterprises (Amazon, TripAdvisor, Booking.com) included means for registered users to be able to share opinions about their buying experiences, offering more sophisticated methods to enrich the review experience, e.g. including the rating or the profile and popularity of the reviewer. This process generates volumes of information, that are commonly referred to as Big Data: projections estimates in 2020 there will be around 40 zettabytes (40 trillion gigabytes of data), including social media and minor companies not solely dedicated to digital services [1].

Opinions are central to most human activities and hence, are one of the key drivers of human behaviors [2] and many studies suggest that online product reviews and related features have a significant impact on consumers' purchase decision and sales [3-5]. Reasons are multiple: on the one hand, consumers can obtain information before making their actual purchase decisions [6], on the other hand, companies attract consumers by providing an online platform that enables customers to exchange their consumption experiences [7].

Businesses and institutions gain valuable insights into the massive amounts of the information they have by applying tools and techniques of Big Data Analytics, i.e. the techniques utilized to examine and process Big Data so that hidden underlying patterns are revealed, relationships are identified, and other insights concerning the application context under investigation are exposed [8]. Opinions, sentiments, and emotions can be captured using the individual's writings, facial expressions, speech, and many other media [9] via Sentiment Analysis which is generally defined as the computerized process of recognizing, detecting, and determining the orientation of human opinion or emotion and its polarity [10]. In our daily life, there are many applications of Sentiment Analysis, mostly concentrated on market intelligence: measuring the degree of user satisfaction on products or services to

improve their weaknesses or developing new products and services, forecasting of price changes according to news sentiments, etc. [11].

Background

The Data Appeal Company, formerly known as Travel Appeal, is an Italian scale-up founded in 2014 specialized in Data Science and Artificial Intelligence. With an initial main focus on the travel industry, it has built the world's largest and most efficient Travel & Location Intelligence Data Lake, mapping in deep detail all travel properties and Points of Interest (POI) and connect them with all data about human experience (text and visual contents, social conversations, reviews, prices, events, bookings) on over 80 online channels. Through its semantic engine, proprietary algorithms and Artificial Intelligence system it can read and process millions of data from different sources to find relevant information, collecting and analyzing online travel data in real time, transforming that data into updated and immediately applicable strategies.

Enlarging its data lake to any POI on a map, made the company evolve and also its solutions ecosystem (Dashboard, API and App) to be applied to any sector (banking, finance, real estate, retail, etc.) having a specific interest on location intelligence and reputation. This led to the idea to use its Artificial Intelligence towards developing sustainability to provide important information regarding all the dimensions involved - economics, environment, social dimensions - at any spatial level as perceived and experienced by humans (local community, visitors, tourists), with an application to the coasts of Sicily.

The Data Appeal Artificial Intelligence has been applied to the coasts of Sicily (largest island of Mediterranean Sea), analyzing over 15000 reviews (texts and scores) on Tripadvisor and Google from a sample of 88 public beaches in order to verify the level of cleanliness perceived by the users and the main factors that determine a positive or negative judgment in the general perception.

Proposed Methodology

The proposed methodology is a complicate process [12-13] that need several steps of analysis, that we briefly summarized in this paragraph.

The starting point of the analysis is to extract information from reviews: the aim is not only to provide a polarity score (sentiment) for each content, but to identify the main topics and the subjects (aspects) and judgments (opinions) connected with these topics. The topic to be analysed can also be very abstract: the strength of the algorithm used is a technique called Word2Vec allowing to represent words through a multidimensional numeric vector. This vector has an important characteristic: words used in similar contexts (e.g. coasts, beaches, ...) have similar vectors, that is "neighbours" in a reference vector space. This closeness allows to enrich the analysis on a given topic with all those terms and / or sentences that cannot be predefined, but that emerge directly from the texts or better from the contexts. As an example, I might be interested in an analysis on the beaches and the algorithm suggests including in the analysis terms such as "beach", "coast", "bay", which widen the perimeter of

analysis. The ultimate goal is to identify all the reviews or phrases related to the topic of analysis.

The second step is to evaluate the polarity of these sentences in order to assert what people think about the topic extracted. In order to do this it has been used a Sentiment analysis model: it is a classic machine learning model in the NLP (Natural Language Processing) field that seeks non-linear dependencies between the various words to "understand" computationally the logics that represent satisfaction and, more generally, the polarity, of a generic text. It is a supervised model, more generally of a neural network that uses an embedding layer to numerically represent the words of a given dictionary, also in this case specific to language. One of the strengths of this algorithm is that it does not require opinions in the text, but manages to provide a multiclass score (positive, negative and neutral) of any text.

Details have to be analysed to:

- Identify key phrases and relevant topics (calculated on sentences that concern our topic of analysis and are therefore contextualized)
- Identify the sentiment of the sentences and consequently the sentiment of the theme analysed
- Identify the opinions connected with these sentences and relate them to the relevant themes of the first point
- Geolocate the POIs where the topic is "discussed" most, as well as the sentiment associated with these POIs
- Identify the temporal point of view the subject being analysed

Results need to be further analysed in order to understand the magnitude of the topics that talk about cleanliness in the review compared with other topics that people obviously discussed inside texts. This led to the creation of 2 classes: one that contains sentences talking about cleanliness (identified by the previous algorithm) and one containing all the other sentences: what emerged overall is that the arguments and opinions people discuss about are repeated.

The final steps include computing a n-gram model (n-gram is a contiguous sequence of n items): an n-gram model is a type of probabilistic language model for predicting the next item in such a sequence in the form of a $(n - 1)$ -order Markov model. In this way it is possible to know which are the most used terms by people inside reviews. Then the calculation of the magnitude of a specific n-gram, i.e. the percentage of document that contain that specific sequence of words.

Results

The top keywords on beaches have a strong relation to element of cleanliness as shown in Table 1.

It covers over 87 % of the reviews mentioning beach, sea, water, sand. This has a direct marketing effect for local businesses and tourism operators, but this led also that cleanliness is a distinctive element for the destination overall, with governance and management implications. In general, the sampled beaches were considered clean, but with a different level of cleanliness and a relative satisfaction. The research further analysed, when possible, the elements who generated the negative impact on cleanliness perception.

Table 1 - Keywords with more than 1000 mentions.

Keyword	Mentions	% related to element cleanliness
<i>Spiaggia</i> (beach)	6175	87 %
<i>Mare</i> (sea)	4235	87 %
<i>Acqua</i> (water)	1737	91 %
<i>Sabbia</i> (sand)	1134	88 %

In figure 1 it is possible to see results of this analysis: it appears that terms more associated with a class are a further distance from the diagonal line between the lower-left and upper-right corners: the presence of waste generated by humans is noticed by travelers. The judgments regarding the presence of garbage are linked to attitudes of carelessness on the part of beach guests that show "incivility" in the management of waste such as "plastic", "bottles", the main elements characterizing the negative impact on the cleanliness perception.

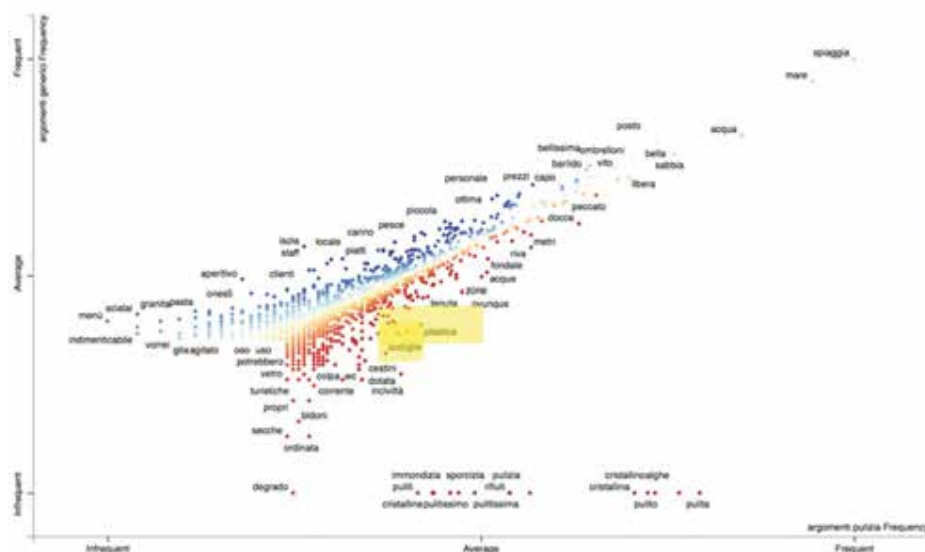

Figure 1 - Frequency of general keywords and cleanliness elements.

Conclusions

This study started with the idea of using reviews, ratings, posts, not for market intelligence proposes, but to foster sustainability. Results showed that this can lead to monitor environmental situation to sites where there wasn't any kind of monitoring, using as bases the free and available contents posted by humans online, processed and analyzed by Artificial

Intelligence. The Regional Government took the results as one of the preliminary studies to enact the new regional plastic-free law for beaches and coastal areas. This first application opens a brand-new world for Artificial Intelligence analysis of human experience big data: all information and tools provided by companies as The Data Appeal Company can become a fundamental source, combined to official statistics, to develop a really integrated and innovative information base towards monitoring sustainability and extending the current statistical frameworks beyond their economic focus, to incorporate environmental, and social dimensions and at relevant spatial levels: global, national and sub-national.

Acknowledgments

This study was supported by the Data Appeal Company.

References

- [1] EMC and IDC (2014) - *The digital universe of opportunities*, Infobrief, April.
- [2] Hu M., Liu B. (2004) - *Mining and summarizing customer reviews*. In Proceedings of the tenth ACM SIGKDD international conference on Knowledge discovery and data mining (KDD '04). Association for Computing Machinery, New York, NY, USA, pp. 168–177.
- [3] Duan, W, Gu, B & Whinston, AB (2008) - *The dynamics of online word-of-mouth and product sales-An empirical investigation of the movie industry*, Journal of Retailing, vol. 84, no. 2, pp. 233-242.
- [4] Forman C., Ghose A., Wiesenfeld, B. (2008) - *Examining the Relationship Between Reviews and Sales: The Role of Reviewer Identity Disclosure in Electronic Markets*, Information Systems Research 19, pp 291-313.
- [5] Elwalda A., Lü K. Ali M. (2016) - *Perceived derived attributes of online customer reviews*, in Computers in Human Behavior 56 pp. 306-319.
- [6] Zhu F., Zhang X. (2010) – *Impact of online consumer reviews on sales: the moderating role of product and consumer characteristics*, J. Mark. 74 pp. 133–148.
- [7] Mudambi S.M., Schuff D. (2010) *What makes a helpful online review? A study of customer reviews on amazon.com*, MIS Q. 34 (2010) pp. 185–200.
- [8] Iqbal R., Doctor F., More B., Mahmud S., Yousuf, U. (2016) - *Big Data analytics: Computational intelligence techniques and application areas*. International Journal of Information Management.
- [9] Yadollahi A., Shahraki A., Zaiane O. (2017) - *Current State of Text Sentiment Analysis from Opinion to Emotion Mining*. ACM Computing Surveys. pp. 1-33.
- [10] Kang D., Park, Y. (2014) - *Review based measurement of customer satisfaction in mobile service: Sentiment analysis and VIKOR approach*. Expert Systems with Applications, 41(4), pp. 1041–1050.
- [11] Soleymani M.et al. (2017) - *A survey of multimodal sentiment analysis*, in: Image and Vision Computing, vol. 65, pp. 3-14.
- [12] Neurocomputing vol. 403 (2020), Elsevier.
- [13] Information Sciences vol. 532 (2020), Elsevier.

STABILIMENTI BALNEARI COME PRESIDI AMBIENTALI. VERSO LA MULTIFUNZIONALITÀ DEI SERVIZI DI BALNEAZIONE. ALCUNE RIFLESSIONI A PARTIRE DAL PROGETTO INTERREG RE.CO.RD.

Federica Epifani, Fabio Pollice¹

Dipartimento di Storia, Società e Studi sull'Uomo, Università del Salento, ex Monastero degli
Olivetani, viale San Nicola, Lecce

e-mail: federica.epifani@unisalento.it; fabio.pollice@unisalento.it

Abstract - The progressive degradation of the landscape, the loss of biodiversity, the difficulty of containing pollution and marine waste are just some of the consequences of a process of extreme littoralisation. As a result, coastal land management is also increasingly complex and requires the involvement of different actors. On the base of the latest experiences of cooperation, such as the INTERREG Re.Co.RD. project, we reflect on how the multifunctional approach can be applied to coastal management and, more specifically, on the role of private actors, such as bathing facilities managers.

1. Introduzione

Il livello di complessità nella gestione delle aree costiere è andato costantemente crescendo nel corso degli ultimi decenni sia per effetto dell'aumento della pressione antropica e delle problematiche ad essa connesse, sia per effetto di una sempre più diffusa sensibilità ambientale che ha portato ad attribuire a queste policy un'importanza centrale nell'agenda politica.

Se nel recente passato, dopo un periodo di completa disattenzione per la dequalificazione delle aree costiere, gli interventi normativi e pianificatori si erano diretti ad azioni di mera tutela degli ecosistemi costieri, più di recente la progressiva adozione dei principi dello sviluppo sostenibile ha portato all'adozione di un approccio pianificatorio sistemico. Gli obiettivi di policy si sono progressivamente spostati dalla preservazione alla riqualificazione e valorizzazione, ampliando il proprio raggio di azione alle relazioni con l'intorno geografico (relazioni orizzontali) e tra l'area costiera e le attività antropiche (relazioni verticali), e sulla rilevanza di queste nell'accrescere i livelli di vulnerabilità.

Il contesto mediterraneo è, in questo senso, paradigmatico. Le coste mediterranee sono aree popolate, con una densità di popolazione significativa (pur rappresentando appena il 12 % della superficie degli Stati che si affacciano sul Mediterraneo, la popolazione costiera supera il 30 %) e presentano tassi di urbanizzazione crescenti [1]. Il progressivo aumento della popolazione che tende peraltro a concentrarsi proprio lungo la linea di costa, creando in molti casi un continuum urbanistico, si accompagna ad un elevato consumo di suolo e ad una generalizzata compromissione degli ecosistemi costieri.

¹ Pur se frutto di una riflessione comune, sono da attribuirsi a Federica Epifani i parr. 1,2 e 3, a Fabio Pollice i parr. 4 e 5

Si stima che, entro il 2030, il bacino del Mediterraneo sarà l'area maggiormente popolata a dispetto della fragilità degli ecosistemi costieri che sono peraltro caratterizzati da più alti livelli di biodiversità [12]. Sulla costa, flora e fauna sono concentrate in aree limitate e ad alta vulnerabilità, ed è proprio nelle aree sublitorali che si registra una maggiore presenza di biodiversità marina. A determinare la dequalificazione dei litorali è anche l'aumento dei traffici marittimi che, oltre a determinare un ampliamento delle strutture portuali e retroportuali ha effetti fortemente compromissori sulle acque marine che tendono a riflettersi maggiormente proprio sulle aree costiere. È in particolare il trasporto degli idrocarburi a rendere palese il conflitto tra gli interessi economici e di approvvigionamento energetico, da un lato, e le istanze di tutela ambientale e paesaggistica, dall'altro, conflitto che sempre più spesso anima iniziative di riappropriazione da parte della comunità locale.

L'impatto maggiore sulle aree costiere del Mediterraneo lo ha tuttavia il turismo, sia perché si tratta di un fenomeno generalizzato che tende a concentrarsi proprio lungo la fascia costiera, sia perché si manifesta con maggiore intensità nelle aree di maggiore valore paesaggistico e naturalistico, giacché questi costituiscono potenti attrattori turistici.

Anche le relazioni delle aree costiere con l'entroterra pongono una serie di criticità dovute al processo di litoralizzazione ossia alla concentrazione di attività economiche nelle aree costiere per effetto sia della crescita urbana e infrastrutturale delle aree costiere (effetto indotto), sia allo sviluppo di attività economiche *site specific* come il turismo (effetto diretto) [5], [7], [10]. Tale processo è stato, invero, stimolato anche da interventi pubblici di sviluppo preferenziale, soprattutto nel settore infrastrutturale, manifatturiero e turistico; questi interventi hanno spesso favorito, quando non determinato, la sovrappopolazione delle aree costiere. L'altra faccia della medaglia è stato un progressivo spopolamento delle aree interne, ad economia prevalentemente rurale, ed il conseguente abbandono delle attività agricole, la perdita delle cultivar tradizionali e più in generale, di terreni agricoli funzionali a soddisfare la crescente domanda di risorse proveniente dalla costa. Due processi opposti, che tuttavia pervengono allo stesso risultato: la perdita di biodiversità e il deterioramento, spesso irreversibile, dei paesaggi.

I processi fin qui descritti sono il risultato dell'adozione di politiche e orientamenti di stampo produttivista che, oltre a caratterizzare la programmazione economica, si sono riflessi anche nella pianificazione territoriale, almeno fino agli anni Novanta, quando si è incominciata a manifestare una progressiva inversione di tendenza. È in questi anni, infatti, che si assiste all'affermazione del paradigma post-produttivista. Un paradigma che trova immediata applicazione con riferimento all'agricoltura, ispirando la nuova politica agricola comunitaria e determinando una profonda revisione del modello di sviluppo delle aree rurali. Il paradigma post-produttivista individua il proprio *driver* nel concetto della multifunzionalità [9], e cioè l'attivazione, accanto alla funzione produttiva principale, della produzione di beni e servizi non legati al mercato ma orientati al benessere ambientale e sociale [6]; [13]. Nello specifico, tali funzioni hanno come obiettivo la tutela dell'ambiente e della biodiversità, il recupero e la valorizzazione del patrimonio culturale materiale e immateriale dei paesaggi, la gestione delle risorse idriche e il monitoraggio del rischio idrogeologico, la sicurezza alimentare, il benessere degli animali [14]; [13]. Negli ultimi anni il concetto di multifunzionalità è stato coniugato secondo un approccio più spiccatamente territoriale [3] e declinato secondo i principi dello sviluppo sostenibile [2]; quest'ulteriore evoluzione mette in luce la rilevanza cruciale ricoperta dal sistema di relazioni, su come queste si dipanano sullo spazio e lo rifunzionalizzano, sul rapporto tra multifunzionalità e prospettive di sviluppo territoriale.

Il paradigma post-produttivista, inscindibilmente legato alle politiche agricole degli ultimi vent'anni, presenta in realtà una multidimensionalità di fondo che lo rende applicabile anche ad altri contesti territoriali come quello costiero [11]. In queste aree, la multifunzionalità ha riguardato principalmente le attività di pesca su piccola scala e le strategie di adattamento messe in atto dai pescatori; in questo senso, la svolta post-produttivista è da intendersi non come un cambio, in termini assoluti, degli orientamenti produttivi, quanto piuttosto come un “bilanciamento” dovuto alla necessità di una diversificazione delle attività, orientate, oltre che alla produzione alimentare, alla creazione e valorizzazione di capitale ambientale, territoriale e sociale [4]; [8]. Invero, l'applicazione dell'approccio multifunzionale in seno al settore della pesca offre degli esempi paradigmatici: su tutti, si fa riferimento all'impiego di pescatori nella raccolta di rifiuti marini. È evidente, quindi, che ripensare la gestione delle aree costiere attraverso la lente della multifunzionalità implica una ridefinizione degli obiettivi di governance e, conseguentemente, anche degli attori, che in contesti altamente vulnerabili come quelli in esame sono chiamati a cooperare per mettere in atto strategie di resilienza. In questa sorta di “mappatura” degli attori territoriali, emerge la rilevanza del settore dei servizi, finora toccati solo marginalmente dalla riflessione teorica sulla multifunzionalità, ma il cui ruolo nei processi di sviluppo territoriale appare di primaria importanza, soprattutto in contesti ad alta intensità turistica.

In questo *paper* ci si focalizza soprattutto sul ruolo degli stabilimenti balneari e sulle potenzialità di questi di porsi come presidi di salvaguardia ambientale e di sensibilizzazione della comunità locale e dei turisti. La riflessione muove dai primi risultati emersi nel corso del progetto Re.Co.RD. - *REcycling strategies for the Coastal sustainable waste management towards R&D Innovation*, finanziato nell'ambito del Programma INTERREG V-A-GREECE- ITALIA 2014-2020.

2. Materiali e metodologia

La ricerca è condotta nell'ambito del progetto RE.CO.RD. - *REcycling strategies for the Coastal sustainable waste management towards R&D Innovation*, finanziato nell'ambito del Programma INTERREG V-A-GREECE- ITALIA 2014-2020 e che coinvolge il Comune di Otranto (capofila), l'Università del Salento e il Comune di Santa Cesarea Terme per la parte italiana, e il Comune di Lefkada e l'Università di Ioannina per la parte greca. Per quanto riguarda in particolare l'Università del Salento, è importante sottolineare il profilo multidisciplinare del team di ricerca, composto da ingegneri, biologi, geografi ed economisti.

Il progetto intende sviluppare nuove strategie volte a limitare l'impatto ambientale delle attività economiche legate al turismo nelle aree costiere. Tale insieme di strategie si basa su due caratteristiche principali: l'applicazione di nuove tecnologie di riciclo e il coinvolgimento sia delle comunità locali che dei turisti.

L'implementazione del progetto aumenterà del 10 % la capacità delle autorità regionali, locali e degli operatori dei servizi pubblici di integrare tecnologie ecocompatibili nelle loro operazioni, con particolare attenzione alle zone costiere e marittime. I siti balneari diventeranno siti protetti al fine di salvaguardare e valorizzare gli ecosistemi costieri.

Questo contributo presenta i risultati dell'analisi di contesto preliminare effettuata sui comuni di Otranto e Santa Cesarea Terme per verificare gli impatti del turismo sul tessuto

sociale ed economico del territorio, nonché sulla capacità di carico del sistema territoriale in relazione alla produzione e alla gestione dei rifiuti, con particolare riferimento alla plastica.

Nello specifico, l'analisi si è basata sull'elaborazione di dati secondari ufficiali relativi:

- alla turisticità dell'area (arrivi e presenze, attività imprenditoriali afferenti al settore);
- alla produzione di rifiuti solidi urbani e all'incidenza della raccolta differenziata nell'arco temporale 2011-2018, al dettaglio mensile.

Sulla base di tali elaborazioni, si sostiene la tesi per cui esiste una correlazione viziosa tra flussi turistici, che nell'area in esame appaiono fortemente stagionalizzati, e gestione dello smaltimento dei rifiuti, la cui produzione aumenta nei mesi estivi secondo un andamento esponenziale. Da queste osservazioni deriva la riflessione teorica in merito al ruolo degli operatori balneari. Si segnala, peraltro, che proprio gli operatori balneari sono direttamente interessati da alcune attività di progetto, parte delle quali, previste per aprile 2020, non hanno potuto avere luogo a causa dell'emergenza sanitaria determinata dal COVID-19.

3. L'impatto del turismo sul territorio costiero

Otranto e Santa Cesarea Terme sono due comuni limitrofi sulla costa orientale della provincia di Lecce. Insieme ad altre località contermini, come Melendugno e Giurdignano, i due comuni rientrano in quella che possiamo considerare una regione naturalmente vocata al turismo, per l'ampia e diversificata concentrazione di attrattori. In particolare, l'area può contare sulla presenza di prestigiosi luoghi di interesse storico e culturale (Otranto con la sua splendida cattedrale; le ville di Santa Cesarea; il più importante parco megalitico d'Italia a Giurdignano, il sito archeologico di Roca) e naturalistico (Laghi Alimini, Punta della Palascia, l'insenatura di Porto Badisco), ma deve di certo la sua attrattività alla qualità delle acque costiere e alla bellezza e varietà del paesaggio costiero che alterna litorali bassi e sabbiosi a bellissime falesie contornate da una ricca macchia mediterranea. Non può dunque stupire che il turismo balneare costituisca uno dei principali motori dell'economia locale. Sia Otranto che Santa Cesarea Terme sono infatti economie prevalentemente turistiche: ad Otranto il 28 % della popolazione è impiegata in attività ricettive, mentre questa percentuale raggiunge il 24,4 % nel caso di Santa Cesarea.

Si tratta di numeri superiori a quelli registrati sia a livello regionale (18,37 %) che provinciale (19 %). A livello imprenditoriale, le imprese del settore dei servizi di ospitalità e della ristorazione rappresentano il 28,5 % del totale delle imprese attive ad Otranto, e il 22,16 % di quelle attive a Santa Cesarea Terme.

La caratterizzazione balneare del turismo provoca un'accentuata stagionalità, con impatti diretti sulla capacità di carico del territorio dovuti principalmente all'aumento della popolazione nei mesi estivi. Negli ultimi anni si è peraltro assistito, a fronte di un tendenziale aumento degli arrivi turistici, ad una riduzione della permanenza media. Si tratta di un fenomeno che, pur essendosi manifestato in larga parte delle destinazioni turistiche costiere dell'area Mediterranea, ha riflessi non solo economici, ma anche ambientali in quanto determina un maggiore stress sulle risorse territoriali.

Tabella 1 - Attività imprenditoriali attive nel settore alberghiero, extralberghiero e ricettivo, nei comuni di Otranto e di Santa Cesarea Terme. Fonte: ns elaborazione su dati Pugliapromozione.
 Table 1 - Business activities active in the accommodation sector in the municipalities of Otranto and Santa Cesarea Terme. Source: www.agenziapugliapromozione.it

Attività imprenditoriale	Otranto	Santa Cesarea T.
Ristoranti	4	2
Stabilimenti balneari	12	6
Centri benessere e termali	0	1
Locali notturni	0	1
Affittacamere	21	3
Agriturismo	47	2
Albergo	26	7
B&b familiare	28	8
B&b imprenditoriale	9	1
Campeggio	6	1
Case e appartamenti per vacanze	25	8
Case per ferie	0	1
Residence	2	1
Residenza Turistico-alberghiera	3	3
Villaggio turistico	2	0
Villaggio albergo	3	0
TOTALE	188	45

Tabella 2 - Arrivi e presenze e permanenza media nei comuni di Otranto e Santa Cesarea Terme, periodo di riferimento 2008-2018. Fonte: ns elaborazione su dati Pugliapromozione.
 Table 2 - Arrivals, room nights and average stay in the municipalities of Otranto and Santa Cesarea Terme, reference period 2008-2018. Source: www.agenziapugliapromozione.it

	Arrivi	Presenze	Permanenza media (giorni)
2008	115054	812188	7,1
2009	122313	818071	6,7
2010	138595	874950	6,3
2011	147031	882046	6,0
2012	147612	865911	5,9
2013	146462	860304	5,9
2014	139367	749969	5,4
2015	150094	778587	5,2
2016	159269	816939	5,1
2017	173520	903620	5,2
2018	171884	802233	4,7

I dati relativi ai flussi sono certamente rappresentativi delle dimensioni del fenomeno, ma non sono esaustivi: a questo computo sfuggono, infatti quelli che vengono normalmente annoverati nella categoria degli “escursionisti” – turisti non pernottanti – , i turisti di rientro – persone originarie di questi luoghi che vi ritornano durante il periodo estivo sfruttando le proprie abitazioni – e tutti quei turisti che sfuggono alle rilevazioni in quanto

trovano ospitalità presso parenti o amici residenti. Di conseguenza, quantificare con certezza l'aumento della popolazione non è impresa semplice.

Tuttavia, un dato utile ad una migliore interpretazione del fenomeno è quello relativo alla raccolta dei rifiuti solidi urbani. Osservando i dati storici relativi alla raccolta dei rifiuti nei due comuni nel periodo 2011-2018, è possibile osservare che durante il periodo estivo la quantità di rifiuti raccolti è sensibilmente superiore ai livelli registrati nei mesi invernali. Per un'osservazione più significativa, potrebbe essere utile osservare la differenza tra la quantità più bassa e quella più alta registrata. Nel caso del Comune di Santa Cesarea, la quantità minima di rifiuti raccolti si riferisce al mese di febbraio per tutto il periodo considerato, mentre le quantità più alte vengono sempre registrate nel mese di agosto; il picco si registra nel 2015, quando i rifiuti raccolti in agosto sono 3,5 volte superiori a quelli raccolti in febbraio; nel 2018 il valore scende a 2,5, raggiungendo il minimo.

Nel caso di Otranto, le quantità più basse di rifiuti raccolti si registrano anche a febbraio, con le sole eccezioni del 2014 e del 2017, quando gennaio è stato il mese con la minore produzione di rifiuti, mentre la quantità più alta si riferisce sempre ad agosto. Nel 2013 i rifiuti raccolti in agosto sono 6 volte superiori a quelli di febbraio. Nel 2018 il divario è di 5 volte. Lo scarto minimo si registra nel 2016, quando i rifiuti raccolti in agosto sono 4 volte superiori a quelli di febbraio.

Un'altra questione da considerare è la diffusione della raccolta differenziata, rilevabile attraverso il rapporto tra rifiuti differenziati ed il totale dei rifiuti solidi urbani. Sia ad Otranto che a Santa Cesarea Terme, la percentuale di raccolta differenziata mostra una drastica diminuzione nella stagione estiva.

È evidente quindi che, all'aumentare della pressione antropica derivante dal turismo, si assiste all'aumento non solo del volume dei rifiuti prodotti (fig. 1) ma anche delle difficoltà legate ad un corretto smaltimento (fig. 2). Queste possono derivare tanto da un'effettiva inadeguatezza dei sistemi di smaltimento nel far fronte a volumi maggiori di rifiuti (superamento della capacità di carico) ma anche da una minore attitudine del turista, del villeggiante o della stessa comunità locale a mettere in atto comportamenti virtuosi.

Nel complesso il turismo se da un lato costituisce un settore strategico per lo sviluppo del territorio, dall'altro presenta un impatto ambientale e paesaggistico che minaccia non solo di compromettere gli equilibri ecosistemici della fascia costiera, ma anche di condurre ad una progressiva dequalificazione di quegli stessi valori attrattivi che ne hanno sin qui determinato lo sviluppo.



Figura 1 - Volume dei Rifiuti Solidi Urbani per mese e anno, dal 2011 al 2018, nei comuni di Santa Cesarea Terme (a) e Otranto (b). Elaborazione su dati www.sitpuglia.it
 Figure 1 - Volume of Urban Solid Waste by month and year, from 2011 to 2018, in the municipalities of Santa Cesarea Terme (a) and Otranto (b). Source: www.sitpuglia.it



Figura 2 - Volume della raccolta differenziata, per mese e anno, dal 2011 al 2018, nei comuni di Santa Cesarea Terme (a) e Otranto (b). Elaborazione su dati www.sitpuglia.it
 Figure 2 - Volume of separate waste collection, by month and year, from 2011 to 2018, in the municipalities of Santa Cesarea Terme (a) and Otranto (b). Souce: www.sitpuglia.it

Occorre dunque porre in essere una strategia di contenimento degli impatti ambientali delle attività turistiche e questa deve indirizzarsi tanto alla domanda, educando i turisti ad una fruizione sostenibile delle risorse ambientali della fascia costiera, quanto all'offerta, portando gli operatori turistici ad adottare azioni volte a ridurre la propria impronta ecologica e contribuire allo sviluppo di un modello di sviluppo sostenibile.

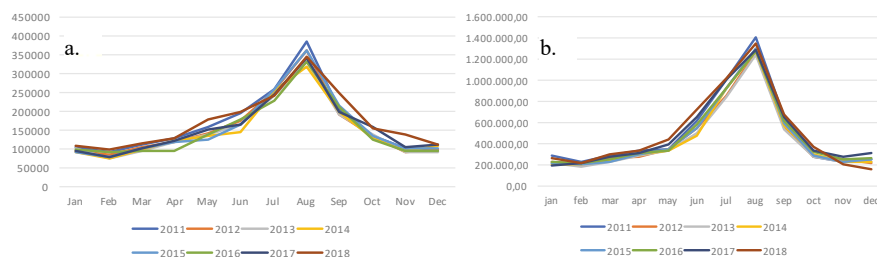
4. Il ruolo degli stabilimenti balneari

In questo quadro, il ruolo degli stabilimenti balneari diventa assolutamente cruciale: attività tra le più attrattive e, nel contempo, tra le più impattanti tanto sul piano paesaggistico, quanto sul piano ambientale e sociale, sono spesso additati come elementi compromissori degli ecosistemi costieri e intorno ad essi si generano conflitti derivanti dalla loro controversa funzione sociale.

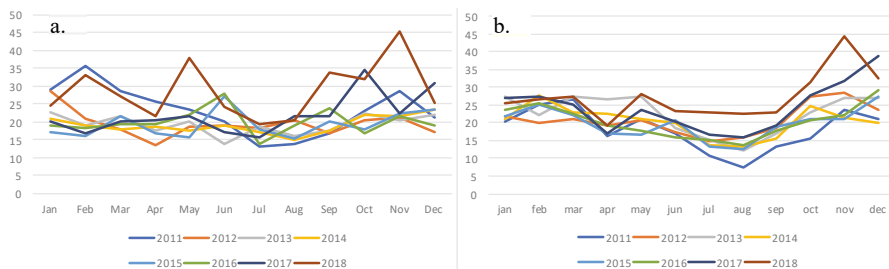
Inserire gli stabilimenti balneari all'interno di un progetto di sviluppo sostenibile del turismo costiero appare di conseguenza un obiettivo difficile, ma di alto valore funzionale e simbolico. Se infatti si riesce a trasformare i lidi da detrattori a presidi ambientali, in grado sia di mettere in atto buone pratiche di contenimento dell'inquinamento costiero, sia di coinvolgere i turisti nel progetto di sostenibilità attuato dagli attori locali, allora si ottiene un effetto dimostrativo sull'intero sistema turistico territoriale, dimostrando che la sostenibilità del turismo è un obiettivo perseguibile e concreto. Di qui la focalizzazione del progetto Re.Co.RD sugli stabilimenti balneari e sul ruolo nella gestione dei rifiuti costieri.

L'idea di fondo è che gli stabilimenti balneari possano operare come dei veri e propri presidi ambientali con funzioni di contenimento dell'inquinamento della fascia costiera di propria competenza e di riqualificazione della stessa, attuata attraverso interventi di manutenzione e monitoraggio della costa.

Con riferimento alla gestione dei rifiuti – focus del progetto – gli stabilimenti possono:

- occuparsi della raccolta differenziata dei rifiuti spiaggiati e in particolare delle plastiche;
- ridurre la produzione di rifiuti con l'adozione di una politica degli acquisti *plastic free*;
- educare i turisti al rispetto dell'ambiente e del paesaggio costiero, informandoli e incentivandoli ad adottare comportamenti ecocompatibili.

Con questa finalità nel corso dell'estate 2019 hanno avuto luogo delle azioni dimostrative in alcuni stabilimenti della costa otrantina, allo scopo di sensibilizzare l'opinione pubblica sui temi della raccolta differenziata e delle opportunità derivanti dal riuso dei rifiuti plastici. In questi stabilimenti si è testato il prototipo di una stampante 3D in grado di produrre semplici gadget in plastica ottenuti dal riutilizzo dei rifiuti raccolti sulle spiagge e tra gli scogli dagli stessi ospiti delle strutture balneari. Nel contempo i turisti sono stati informati sui danni ambientali prodotti dai rifiuti plastici e sensibilizzati rispetto all'obiettivo del contenimento questi rifiuti e sull'esigenza di contribuire alla loro raccolta.

Gli stabilimenti hanno così potuto dimostrare di poter divenire parte attiva del progetto di sviluppo sostenibile del turismo e proporsi effettivamente come dei presidi ambientali con funzioni diversificate che vanno dal monitoraggio dell'inquinamento costiero alla formazione/informazione dei fruitori della fascia costiera.

Il progetto avrebbe dovuto prevedere dei momenti di formazione degli operatori balneari, al fine di favorire il processo di empowerment e, quindi, la proattività degli stessi nel farsi promotori di attività di sensibilizzazione (a livello micro) e di iniziative di rete capaci di incidere a livello strategico (livello di governance), ma l'emergenza sanitaria ha impedito la realizzazione di queste attività.

L'intento tuttavia è quello di riprenderle a breve, portando gli stabilimenti balneari alla certificazione ambientale ai fini del Regolamento EMAS, così da realizzare pienamente l'obiettivo di un loro accreditamento come presidi ambientali della costa otrantina.

5. Discussione e conclusioni

L'esperienza maturata nell'ambito di questo progetto offre le basi per una serie di considerazioni a partire dalle quali poter determinare un set di indicazioni strategiche genericamente replicabili in merito alla governance dei sistemi costieri, agli attori da coinvolgere e, conseguentemente, al ruolo che questi sono chiamati a ricoprire in funzione di una vision condivisa [5]. In questo senso, il coinvolgimento degli stabilimenti balneari all'interno del progetto Re.Co.RD. si pone come esperienza paradigmatica, seppur in una dimensione sperimentale, nello sviluppo di strategie efficaci per la gestione dei rifiuti plastici ed il contenimento dell'inquinamento delle aree costiere. Come evidenziato, l'obiettivo è quello di agire su un duplice livello. A livello micro, rappresentato dalla dimensione aziendale, gli operatori balneari sono chiamati ad adottare delle scelte imprenditoriali specifiche le quali, se da un lato si connotano per un forte valore aggiunto, dall'altro possono comportare, quantomeno nel breve termine un innalzamento dei costi di gestione o una perdita di guadagno. Anche per questo motivo, ripensare lo stabilimento balneare in un'ottica multifunzionale può spingere ad una diversificazione delle attività, le quali possono coincidere con le istanze di preservazione del paesaggio costiero e di promozione di una certa attitudine ecologica tra gli individui: il riferimento è all'organizzazione di eventi ad hoc di pulizia degli arenili, alla previsione di premi e sconti in cambio di un certo quantitativo di rifiuti raccolti e conferiti, all'utilizzo e vendita di prodotti di materiale riciclato o riciclabile.

A livello territoriale, l'adesione da parte degli stabilimenti balneari a dei principi condivisi di sostenibilità può promuovere dei processi virtuosi di *networking*; questi, a loro volta, potrebbero rafforzare il ruolo degli stabilimenti balneari nella governance della destinazione turistica. In altri termini, quella che a livello micro si configura perlopiù come

una scelta imprenditoriale, a livello territoriale trova le precondizioni per proporsi come un indirizzo strategico territoriale; non si tratta, cioè, solo di mettere in atto delle indicazioni sancite a livello normativo². Per l'imprenditore balneare si tratta di acquisire un ruolo di *key actor* nella strategia di riposizionamento competitivo della destinazione turistica, rafforzando il proprio ruolo sociale e, addirittura, ribaltando il proprio ruolo ambientale e assumendo una funzione attiva nello sviluppo di un modello di sviluppo sostenibile del turismo balneare.

In quest'ottica, gli operatori balneari sono a pieno titolo assimilabili ai contadini custodi di Van der Ploeg e questo nel turismo corrisponde a un ribaltamento del rapporto tra turismo e ambiente: il turismo, se ispirato ai principi dello sviluppo sostenibile, può davvero contribuire alla riqualificazione ambientale e paesaggistica delle nostre coste.

Riferimenti

- [1] Beriatos E., Papageorgiou M. (2010) - *Towards Sustainable Urbanization and Spatial Planning of the Coastal Zone in Greece and the Mediterranean Basin*. In 46th ISOCARP Congress, September 2010, pp. 19-23.
- [2] Fanfani D., Mataran Ruiz A. (2009) - *Governance del territorio agro forestale, sviluppo rurale e paesaggio. Possibilità e strumenti per una integrazione*, Il progetto dell'urbanistica per il paesaggio - Atti della XII Conferenza Nazionale SIU, Bari, 19-20 febbraio 2009, Bari, Mario Adda Editore, pp. 1-7
- [3] Fuschi M. (2012) - *La valorizzazione turistica dei paesaggi agro-culturali: una interpretazione geografica*. *Annali del turismo*, 1, pp. 23-38.
- [4] Mather A. S., Hill G., Nijnik M. (2006) - *Post-productivism and rural land use: cul de sac or challenge for theorization?* *Journal of Rural Studies*, 22(4), 441-455.
- [5] Pollice F. (2018) - *Valorizzazione dei centri storici e turismo sostenibile nel bacino del Mediterraneo*, *Bollettino della Società Geografica Italiana*, 1(1) pp. 41-56.
- [6] Pollice F. e Al., (2012) - *Gli spazi guadagnati. La multifunzionalità dello spazio rurale*, in Pollice F. (a cura di), *Rapporto Annuale 2012. I nuovi spazi dell'agricoltura*, Coll. Scenari Italiani, Società Geografica Italiana, Roma, pp.81-107.
- [7] Pollice F. (2010) - *Tourism Competitiveness in the Mediterranean Region*, in Trapani F., Ruggieri G. (eds), III IRT International Scientific Conference "Integrated Relational Tourism Territories and Development in the Mediterranean Area, pp.375-386.
- [8] Prospero P., Kirwan J., Maye D., Bartolini F., Vergamini D., Brunori G. (2019) - *Adaptation strategies of small-scale fisheries within changing market and regulatory conditions in the EU*. *Marine Policy*, 100, 316-323.
- [9] OECD (2008) - *Multifunctionality in Agriculture: Evaluating the degree of jointness, policy implications*, OECD Publishing, Paris, <https://doi.org/10.1787/9789264033627-en>

² A solo titolo esemplificativo si fa presente che, nel 2019, con apposita Ordinanza Balneare, la Regione Puglia ha vietato alle spiagge di vendere materiali usa e getta (stoviglie, cannucce, bottiglie d'acqua di plastica), anticipando di due anni la normativa europea e divenendo la prima regione italiana a bandire la plastica dai propri stabilimenti balneari. Certamente è ancora presto per poter verificare gli effetti di questa norma che, considerando alcune deroghe e persino una sospensione, risulterà realmente effettiva solo a partire dall'estate 2020.

- [10] Salizzoni E. (2010) - *Paesaggi protetti, laboratori di sperimentazione per il paesaggio costiero mediterraneo*. In III Simposio, Il Monitoraggio Costiero Mediterraneo: Problematiche Tecniche di Misura, Livorno giugno 2010, pp. 186-193.
- [11] Salmi P. (2015) - *Constraints and Opportunities for Small-Scale Fishing Livelihoods in a Post-Productivist Coastal Setting*, Sociologia Ruralis, 55(3)
- [12] Scoullou M. J. (2003) - *Impact of anthropogenic activities in the coastal region of the Mediterranean Sea*. In International Conference on the Sustainable Development of the Mediterranean and Black Sea Environment, May, Thessaloniki, Greece.
- [13] Spagnoli L., Mundula L. (2019) - *Nuovi modelli di agricoltura per nuovi paesaggi rurali. Dal paradigma produttivista alla multifunzionalità* in Franco Salvatori (a cura di) L'apporto della Geografia tra rivoluzioni e riforme. Atti del XXXII Congresso Geografico Italiano (Roma, 7-10 giugno 2017), A.Ge.I., Roma, 2019, pp. 2425-2433.
- [14] Van Huylbroeck G., Vandermeulen V., Mettepenningen E., Verspecht A. (2007) - *Multifunctionality of Agriculture: a Review of Definitions, Evidence and Instruments* in Living Reviews in Landscape Research, 1, pp.1-38

LACOAST ATLAS: A CONSISTENT DATABASE TO SUPPORT SUSTAINABLE COASTAL ZONE MANAGEMENT

Maria Antonietta Esposito¹, Filippo Bosi²

¹ Università degli Studi di Firenze, TxP Research UNIFI,
via della Mattonaia 14 - 50121 Florence (Italy)
phone +39 055 2755410, e-mail: mariaantonietta.esposito@unifi.it

² Università degli Studi di Firenze, TxP Research UNIFI,
via della Mattonaia 14 - 50121 Florence (Italy)
phone +39 055 2755410, e-mail: filippo.bosi@unifi.it

Abstract – The European Union Demonstration Programme on Integrated Management in Coastal Zone (1999) addresses most problems of the coastal areas to the criticalities of policies, planning and procedural tools, deriving from an overall lack of awareness about the economic, social and strategic importance of coastal zones sustainable management. Moreover, in Europe it is difficult to assess unique coastline definitions. In some countries the coastline coincides with administrative limits of the country, in others is a physical limit dictated by sea level fluctuations. The paper illustrates the LaCoast Project (LAnd cover changes in COASTal zones), a harmonised and consistent geo-referenced database that constitute a base tool for integrated spatial analysis of policies. It is meant to support sustainable management of the coastal areas through the collection of information about their state and the impact of anthropic activities on them. The aim of the project and its tools is assisting the development of tailored European policies for coastal zone management to be used both at regional and national level. LaCoast objectives were quantifying the changes of land cover for the European coastal zones, providing information to develop environmentally related indicators for the European Environment Agency and foster the use of earth observation data for operational use of vast area management.

The LaCoast Atlas data was gathered thanks to the efforts of an international team that in addition to performing the selection of similar Spectral Bands composition images from Corine Land Cover databases, followed by a geometric correction of Landsat images also performed a quality control process checking the completeness, geometry and topology of data. The investigation also dealt with the changes happening to the coastline and coastal zone, building a matrix of changes to evaluate land cover class changes for the investigated areas. Quantitative and qualitative information about land cover changes and their nature is meant to provide useful indicators to assist European coastal zones management and to support decision-making. LaCoast Atlas offers an overview of both spatial distribution and extension of coastline changes, sided by statistical analysis that quantify coast changes and their nature.

Important indicators for coastal zone sustainable management can be extracted from the data collected in the atlas, to assess land use thanks to the integration of protection of nature information, socio-economic information and administrative data. Land cover changes analysis is fundamental and instrumental to forecast trends and tendencies of future land use.

Introduction

The most important requirement for sustainable management of coasts and coastal areas is having information about the state of such areas, in addition to an archive of the consequences and effects of anthropic impact on them. Use of land and its cover change over time and space, influencing and being reciprocally influenced by human-environment interactions, climate change, socio-economic changes and even changes in biodiversity. Many types of land uses are pressing on coastal zone nowadays, therefore investigating land change processes and identifying root causes and motives leading to landscape transformation is particularly relevant. As shown by history, anthropic use and human processes have transformed and affected coastal areas during the development of humanity, up to the point that coasts have been instrumental for development of society. This is due to their importance in food production, biodiversity preservation and nature protection, in addition to their relationship with the job market throughout history, economic growth, groceries production and all sea-related activities such as fishmongering, mobility, commerce.

The dynamics of coastal areas were influenced by human presence and activities, mostly by the introduction of elements of disturbance such as infrastructure and urban development, excessive exploitation of resources. These dynamics compromised the evolution of coastal zones, resulting in many cases in the disruption of coastal habitats and their capacity to perform basic functions.

On the one hand, to understand the changes that coastal areas have undergone it is fundamental to assess land use and changes in land cover. On the other, understanding these processes are fundamental to predict scenario changes in the future and transformations of coastal zones. To achieve this is fundamental to have a standardized, harmonized and mostly geo-referenced database for land cover and use, providing an accurate representation of the happening phenomena and usable statistics to design such scenarios.

Aim of the LaCoast Project and Project Organization

The LaCoast Project (LAnd cover changes in COASTal zones) is a harmonised and consistent geo-referenced database that constitute a base tool for integrated spatial analysis of coastal areas development policies. It is meant to be used at local, national and European level to provide assistance in the development of European shared policies. The main aims of the project are:

- Quantify land cover changes that have affected the European coastal zones;
- Contributing to the European Commission demonstration Programme on Integrated Management of Coastal Zones (IMCZ), covering the coastal changes of the last decades;
- Support and integrate the reporting activities of the European Environment Agency (EEA), laying the base for deriving environmental indicators and trend indicators for land use change;
- Promote the use of observation and georeferenced data during scenario predictions for large areas.

The Agriculture and Regional Information System Unit (ARIS) and the Space Applications Institute of the European Joint Research Centre (SAI JRC) coordinated the

project, involving National Teams for local surveys and data collection. Belgium, Denmark, France, Germany, Greece, Italy, Ireland, Netherlands, Portugal and Spain have taken part to the project with national and regional teams, in addition to national institutions and Universities supporting the project itself.

The presence of multiple teams from different backgrounds required for a standardized methodology and harmonized processes, information standards and definitions, in addition to accurate quality control at every step and sub-step of the database generation process. To overcome this challenge, the Joint Research Centre provided an initial training to all local teams with the purpose of integrating national results with the European database and its quality control.

Coastal Zones

Coastal zone definition varies according to the reference framework, be it a different nation or administration. From time to time, coastline and coastal zones are ruled by administrative and physical limits or in some cases are affected by fluctuations of sea level. Therefore, aiming to a shared and standard definition, the workgroup agreed on the definition provided in the GISCO database for coastal erosion. Since the LaCoast project focuses on the land portion of the coastal areas, its boundaries needed to be defined, hence determining the width of the landstrip to take into account for the database building. To achieve this, 1 km wide buffers were determined following the Corine Land Cover (CLC) Level 1 items, ranging from 0 to 20 km from the coastline. These study buffers have been confronted with the CLC database, calculating its coverage percentage. The evolution of surface percentage occupied by coastal areas in the study framework is depicted in the following Figure 1.

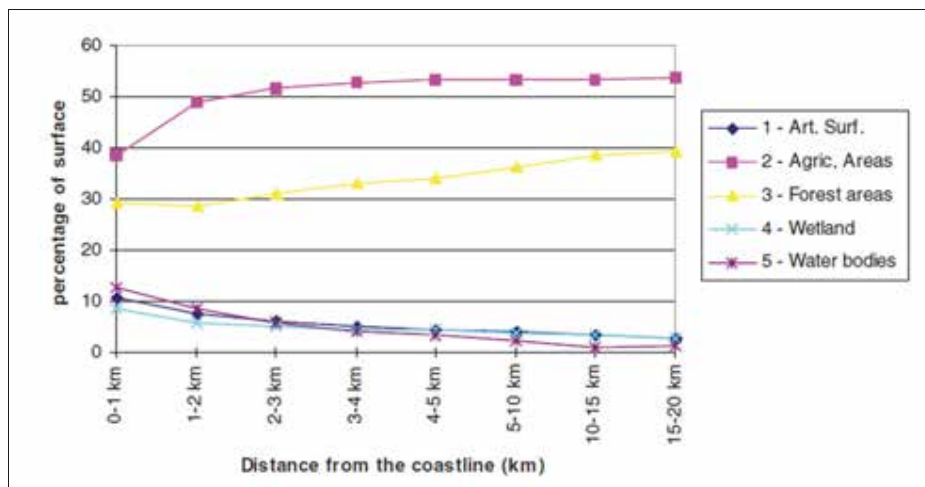

Figure 1 - Changes in land cover in relation to distance from the coastline [13].

Taking into account the outcome of this initial investigation, for the sake of building the LaCoast Atlas it was agreed to consider as coastal area a 10 km wide strip starting from the coastline. The choice is motivated by the relative consistency of land use classes percentages over this distance from the coastline. In addition to this, given the parametric costs calculated at the onset of the project, setting the sharp 10 km limit contributed in keeping the costs and information need under control, going in the direction of keeping in check the overall cost of the project.

Drawing useful elements from the above paragraph, the final definition of LaCoast Coastal Zone is “the land surface included in a 10 km wide strip from the coastline”.

Data Collection

Multiple data sources have been combined to constitute the LaCoast Atlas database. The three main sources were the Corine Land Cover (CLC) Database, Earth Observation Data acquired through satellite images and available MSS Landsat data. Additional details regarding how each data type has been selected and used is provided in the following paragraphs.

Corine Land Cover Database

The Co-ordinate of Information on the Environment (CORINE, CLC in short) programme started in 1985 thanks to the joint efforts of the European Council and the European commission. Its scope was the gathering and coordination of information regarding the state of the environment and natural resources to ensure its consistency and usability.

Building this data with a homogenous methodology resulted in comparable and consistent data about land cover. All data collected in the CLC Database is geo-referenced and collected in a three-level hierarchy. Land Cover and land use is categorized under forty-four different types, and represented with the minimum scale of 1:100.000 in 25 ha unit plots. The CLC Database was built deducting the land use from satellite images and compiled between 1985 and 1995.

On top of providing the Land Cover data as a reference, LaCoast Atlas uses a similar data output and representation methodology, consistent with the CLC data, to map the changes. In addition to the CLC Database, Earth Observation Data and Landsat spectral images have had an instrumental role in building the LaCoast Atlas. Images captured by satellites cover large areas, defining the spectrum and cover consistency of land zones and are particularly useful when dealing with wide areas such the ones object of study [3; 6; 8; 9]. Taking into account that the first pictures obtained throughout the Landsat Multi-Spectrum Scanner are from 1975, it was possible to investigate images for a 20 year span, analysing the progressive changes in land cover. Nevertheless, investigating a large time window not only allowed to cover the entirety of the study areas, but also to have multiple progressive images of certain zones. If on the one hand the Landsat MSS images provided important information for Coastal Zones Land Cover Changes determination, on the other hand difficulties have been encountered by the research team due to discrepancies and asymmetries in the image quality. It was estimated that about 20 % of the images provided by the Landsat MSS were compromised (e.g. by the presence of clouds of obstacles) and/or lacking in quality to properly assess land use.

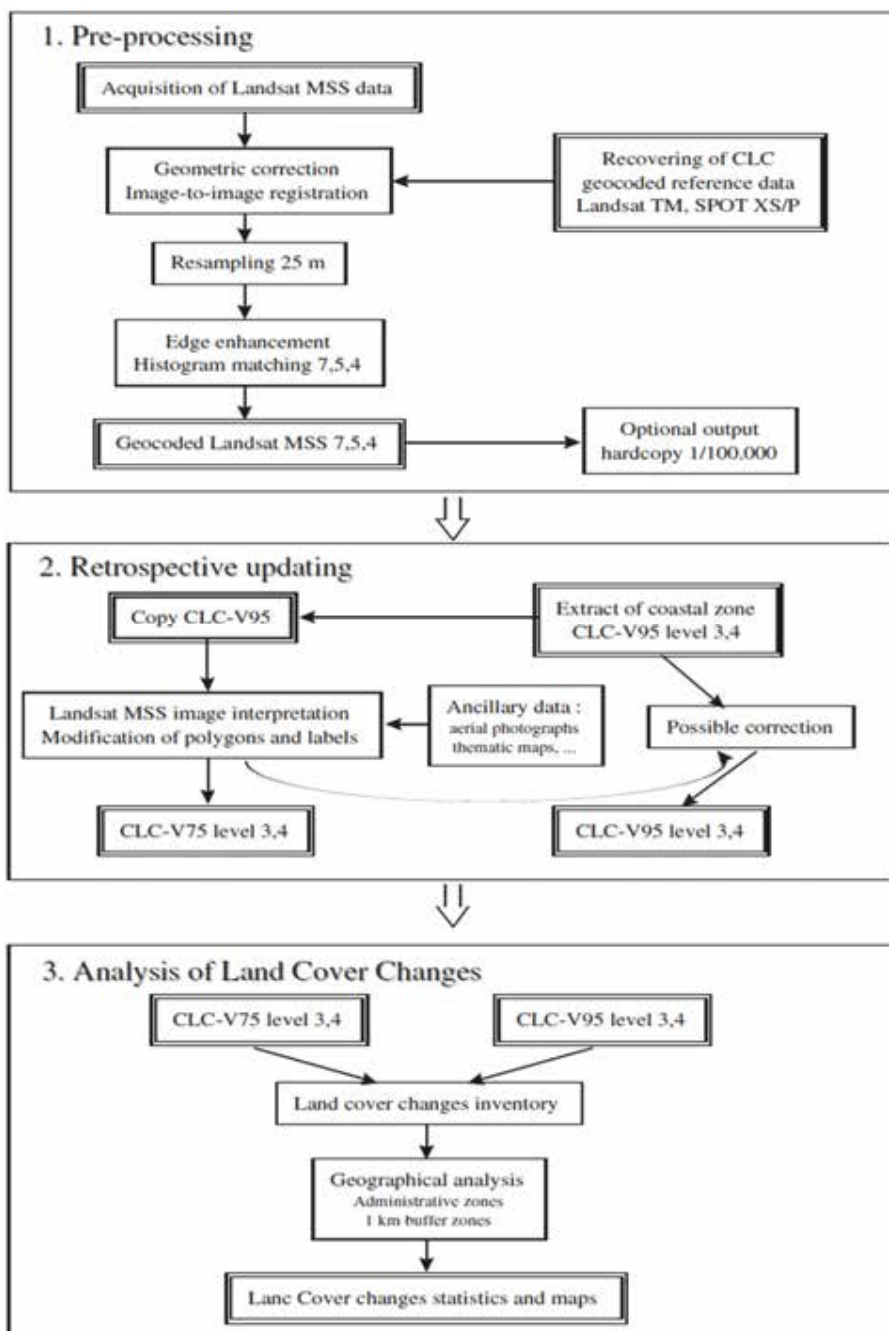

Figure 2 - Land Cover Changes analysis method [13].

Data Interpretation and Database building methodology

Given the large amount of images involved in the investigation and the difficulty in assessing whether changes appearing in the images were due to researchers' interpretation or actual change, the research group needed a shared and agreed definition for the subject of study: changes in land cover for coastal areas. This definition was particularly important considering the multiple sources of information. To use a shared definition of Coastal Zones changes, interpretations and transformation of the source data was needed to use them and compare:

- Selection of comparable composition of spectral bands: throughout the different origin databases, selected spectral bands were selected. Channel 7, 5, 4 for the Landsat MSS images and channels 1, 2, 3, 4, 5 for CLC Landsat and SPOT XS Images;
- Geometric correction of Landsat MSS Images: all images have been resampled to the same standard to obtain comparable images, using convolution transformations to make all images comparable with reference satellite data;
- Histogram Matching: the color composition histograms of all images were compared and aligned, using the MSS images as reference.

The identification of changes was performed with a direct comparison of the same grid unit images from different years, normalized in the previous steps. Every pixel of the images – equivalent to a twenty-five by twenty-five meters plot – was compared to assess land use, drawing useful elements to analyze its changes in time. As reported above, the outcomes of this interpretation and evaluation steps are categorized according to the CLC Database standards and validated in an iterative process by the various local research team, integrating were needed or data was misinterpreted. The final assembly of data and comparison of the outcome of every team was performed by the JRC, which also performed a quality and consistency control on the whole database. The pre-processing, updating and analysis of data is summarized in Figure 2.

Development of Database nomenclature standard

As mentioned above, the nomenclature standard of the LaCoast Atlas derives from the CLC Database, aiming to maximize the consistency of land cover category identification over time. The nomenclature standard is based on the following criteria:

- Scale of the map;
- Base map unit;
- Source data origin (i.e. satellite data)

In addition to all of the above, additional requirements have been integrated in the nomenclature, such as forbidding the use of the “unclassified” category and/or nomenclature terminology that may result ambiguous (also due to possible translation and language bias). Moreover, the nomenclature system has the additional requirement of being simple to read but exhaustive. The result of this nomenclature definition work is a three levels system, each composed of multiple items.

Level 1

This level of nomenclature defines the larger area at a global study level. It is composed of five items.

- | | |
|----------------------------------|-----------------|
| 1. Artificial surfaces | 4. Wetlands |
| 2. Agricultural areas | 5. Water bodies |
| 3. Forest and semi-natural areas | |

Level 2

The second level, hierarchically subject to Level 1, is composed of 15 items and is used at the working scales of 1:1.000.000 and 1:500.000.

- | | |
|--|---|
| 1. Urban fabric | 9. Forests |
| 2. Industrial, commercial and transport units | 10. Shrub and/or herbaceous vegetation clusters |
| 3. Mine, dump and construction sites | 11. Open spaces with little or no vegetation |
| 4. Artificial non-agricultural vegetated areas | 12. Inland wetlands |
| 5. Arable land | 13. Coastal wetlands |
| 6. Permanent crops | 14. Inland waters |
| 7. Pastures | 15. Marine waters |
| 8. Heterogeneous agricultural areas | |

Level 3

The third hierarchical level of the nomenclature system includes 44 items and is used at the smaller working scale of 1:100.000.

- | | |
|--|------------------------------------|
| 1. Continuous urban fabric | 23. Broad-leaved forest |
| 2. Discontinuous urban fabric | 24. Coniferous forest |
| 3. Industrial or commercial units | 25. Mixed forest |
| 4. Road and rail networks and associated land | 26. Natural grassland |
| 5. Port areas | 27. Moors and heathland |
| 6. Airport areas | 28. Sclerophyllous vegetation |
| 7. Mineral extraction sites | 29. transitional woodland shrub |
| 8. Dump sites | 30. Beaches, dunes and sand plains |
| 9. Construction sites | 31. Bare rock |
| 10. Green urban areas | 32. Sparsely vegetated areas |
| 11. Sport and leisure facilities | 33. Burnt areas |
| 12. Non-irrigated arable land | 34. Glaciers and perpetual snow |
| 13. Permanently irrigated land | 35. Inland marshes |
| 14. Rice fields | 36. Peat bogs |
| 15. Vineyards | 37. Salt marshes |
| 16. Fruit trees and berry plantations | 38. Salines |
| 17. Olive groves | 39. Intertidal flats |
| 18. Pastures | 40. Water courses |
| 19. Annual crops associated with permanent | 41. Water bodies |
| 20. Crops | 42. Coastal lagoons |
| 21. Complex cultivation patterns | 43. Estuaries |
| 22. Land principally occupied by agriculture with significant areas of natural | 44. Sea and ocean |

For the sake of readability and simplicity of use – also by non-technical members of the project organization - it was decided to have a non-relational hierarchical nomenclature

system organization, with every level branching into the next one. Table 1 summarizes and explains the hierarchy of levels and items.

Table 1 - LaCoast Atlas Nomenclature structure [13; 14]

Level 1	Level 2	Level 3	
1. Artificial surfaces	1.1. Urban fabric	1.1.1. Continuous urban fabric	
	1.2. Industrial, commercial and transport units	1.1.2. Discontinuous urban fabric	
		1.2.1. Industrial or commercial units	
	1.3. Mine, dump and construction sites	1.2.2. Road and rail networks and associated land	
	1.4. Artificial non-agricultural vegetated areas	1.2.3. Port areas	
		1.2.4. Airport areas	
		1.3.1. Mineral extraction sites	
		1.3.2. Dump sites	
		1.3.3. Construction sites	
		1.4.1. Green urban areas	
		1.4.2. Sport and leisure facilities	
	2. Agricultural areas	2.1. Arable land	2.1.1. Non-irrigated arable land
		2.2. Permanent crops	2.1.2. Permanently irrigated land
2.3. Pastures		2.1.3. Rice fields	
2.4. Heterogeneous agricultural areas		2.2.1. Vineyards	
		2.2.2. Fruit trees and berry plantations	
		2.2.3. Olive groves	
		2.3.1. Pastures	
		2.4.1. Annual crops associated with permanent crops	
		2.4.2. Complex cultivation patterns	
		2.4.3. Land principally occupied by agriculture with significant areas of natural	
3. Forests and semi-natural areas	3.1. Forests	3.1.1. Broad-leaved forest	
	3.2. Shrub and/or herbaceous vegetation associations	3.1.2. Coniferous forest	
		3.1.3. Mixed forest	
	3.3. Open spaces with little or no vegetation	3.2.1. Natural grassland	
		3.2.2. Moors and heathland	
		3.2.3. Sclerophyllous vegetation	
		3.2.4. transitional woodland shrub	
		3.3.1. Beaches, dunes and sand plains	
	3.3.2. Bare rock		
	3.3.3. Sparsely vegetated areas		
	3.3.4. Burnt areas		
	3.3.5. Glaciers and perpetual snow		
	4. Wetlands	4.1. Inland wetlands	4.1.1. Inland marshes
4.2. Coastal wetlands		4.1.2. Peat bogs	
		4.2.1. Salt marshes	
		4.2.2. Salines	
		4.2.3. Intertidal flats	
5. Water bodies	5.1. Inland waters	5.1.1. Water courses	
	5.2. Marine waters	5.1.2. Water bodies	
		5.2.1. Coastal lagoons	
		5.2.2. Estuaries	
		5.2.3. Sea and ocean	

To deal with the complexity of land use during data survey – while at the global scale the aforementioned nomenclature was considered a standard – local teams working a smaller scale could use additional levels and items for their own data processing purposes.

The additional levels 4, 5 and 6 also had requirements:

- Every new sub-level and item had to be a sub of an already existing item;
- Every new item must be related to only one upper level item;
- Every new item has to identify an unambiguously discernible land use item and be understandable based on satellite images.

For example, many local teams decided to create additional items to distinguish between sport-aimed and leisure-aimed within “Green Urban Areas”.

Quality Assessment Process

Quality assessment of the source and output data was performed on two levels. First at local level by the single teams, then at a global, consistency level by the JRC. The scope of the quality assessment is checking the geometry, topology, completeness and consistency of provided data. The quality assessment process also included the definition of a matrix of land cover changes. This matrix was investigated thoroughly to verify the statements on land cover changes over time, excluding the less probable items.

Project challenges

During the development of the LaCoast Atlas, the research team encountered some challenges. These are mostly related to output data consistency and geometric accuracy at the base of image interpretation.

Harmony and consistency of product output

Difficulties were encountered in the definition and formulation of the atlas, given its pan-European and international coverage. Most of this difficulties and criticalities were caused by misinterpretation of source data and metadata of the satellite images. Minor issues were also caused by differences in the reference systems adopted for certain image analysis by the teams and by local data policies.

These generated a series of issues of image interpretation impacting some steps of the workflow, leading to sub-par outcome of certain analysis. After the iterative process of analysis, review and improvement of the output data, in some cases sub-optimal products have been accepted due to logistic, financial or time constraints. Additional rework of data would have impacted time and monetary resources more than including un-optimized data.

Accuracy of geometry data

The LaCoast Atlas is based on satellite images and projections that vary immensely in scale, ranging from entire continent projections to smaller scale detail images. At the larger

scales, equal area projections are traditionally used: it is assumed that planet Earth is spherical, with non-appreciable discrepancies from the actual situation at the working scales of 1:1.000.000 and 1:500.00. Given the fact that LaCoast also operates with 1:100.000 cartography and images, the methodology used to determine large area maps becomes an issue. Due to this discrepancies, the team encountered difficulties in comparing statistical analysis done at different scales, as not all investigated areas had detailed material and images available.

Results

The LaCoast Atlas provides quantitative information regarding land cover changes over time and the nature of land cover on coastal zones. This information is at the base of management and decisional processes for territorial administration [1; 2; 4; 5; 11].

The information is presented in a database whose data is available through the means of queries. The query results provide at first glance an outline of the land cover changes in time. An example of query result is presented in Figure 3.

Area	Perimeter	Polygon-ID	CLC4-V75	CLC4-V95	country code	province code	Commune code	Distance
			2110	1330	4	41	412	2000

Figure 3 - Example of the LaCoast Atlas database structure [13].

In addition to database building, the team performed statistical analyses on the available data to understand in numerical terms the changes happened in coastal zones in the recent decades [6; 7]. These analyses were performed on the whole European coastal area including small islands. LaCoast Atlas offers an overview of both spatial distribution and extension of coastline changes, sided by statistical analysis that quantify coast changes and their nature.

Important indicators for coastal zone sustainable management can be extracted from the data collected in the atlas [12], to assess land use thanks to the integration of protection of nature information, socio-economic information and administrative data. Land cover changes analysis is fundamental and instrumental to forecast trends and tendencies of future land use. Statistical data represents the changes at levels 1, 2 and 3 of the LaCoast/CLC nomenclature database.

Changes in land cover are observed at all three levels of the standard LaCoast nomenclature structure, assessing both the changes happening in major (item) categories and in their sub-items. The changes are expressed both in absolute and relative units, with the latter represented by the ratio between the total land cover surface and the surface impacted by change. Observing the LaCoast Atlas data, most of the land cover change is observed at level 2. Change percentages at this level are generally three times higher in comparison to level 1.

Taking into account the outcomes of the study, Agricultural areas are by far the prevalent land use of the analyzed area. In addition to this, their changes are the biggest

happening in the investigated period, with many of these territories changing between cultivation and arable land multiple times. In certain cases – such as the Netherlands territories – not only the land use changes, but due to the construction of new ridges and canals, new water bodies and greenfield land are determined by anthropic actions.

Artificial surfaces are the largest growing item in land use, observable mostly at regional and national scale rather than local. The average annual rate of land cover tends to be low, but when observed at the national level, coastal zones cover by urban fabric increases drastically.

Land change over time for coastal zones is summarized in Figure 4, that groups land cover classes and provides indicators to determine trends in land cover changes. The table matches the geometric units of the database, indicating their extension and the specific extension of every item in said units.

LaCoast Atlas data has also been associated with socio-economic data to further analyze the trends of changes in coastal zones, identifying how land use change and socio-economic conditions have effected land cover. The results of the study have been used also both at international and local level. For example, the European Environment Agency used the LaCoast database to build reports on the state of the European environment, while local authorities have used the database for coastal management purposes.

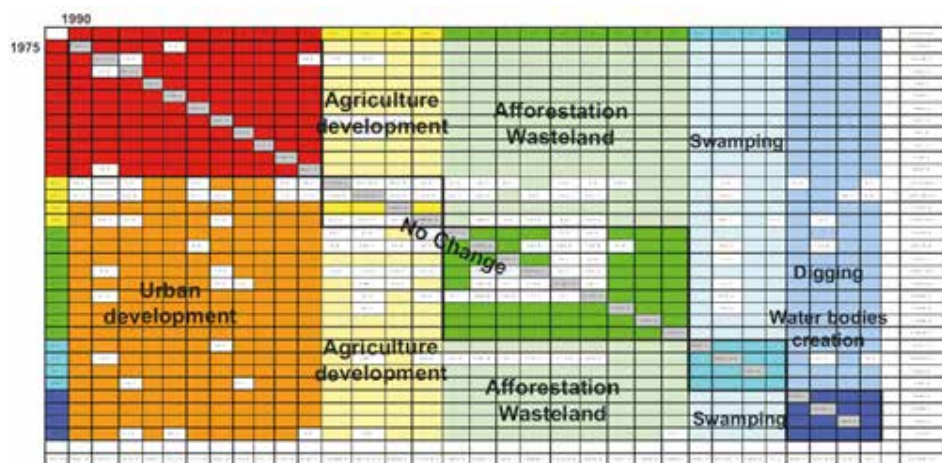

Figure 4 - Matrix of land cover and land use change for units 111-523 [12].

Conclusions

LaCoast Atlas represented an early step (1999) in assessing land use and land cover for coastal areas of Europe. It used for the first time remote sensing data for land cover/use information. Combining land cover change data with socio-economic information, administrative data and other relevant indicators, applying such kind of methodology is useful to forecast future trends and potential local changes of land use and land cover at low cost. Achieving this, LaCoast Atlas was an excellent example of consistent information source built

on historical land use and harmonized with already existing databases. To detect time dynamics is an essential dimension for land cover and land use study: integrating time, LaCoast Atlas constituted a reference for reliable data bases not only for future trends forecasts, but also for the analysis of management policies and their impact on coastal land cover.

Future Perspectives

Looking at the technology evolution from 1999 to nowadays we can observe how digitalization in earth remote sensing observation is now much more advanced. The International Space Station (ISS) and a great number of satellites devoted to many uses are gathering immense quantities of different data by many type of sensors in each pass. Computers and software are more and more powerful and able to manage multilayered analysis for any kind of purpose. Still, the methodology put in place by the LaCoast Atlas can be a reference to design new projects [10] aimed at earth observation and time framed analysis. Reporting on this experience fosters the need to push interdisciplinary research and involve more the user communities to mine the potential use of the data from space observation. In the future, we should continue to look at the space technology to achieve innovation results on mankind activities.

References

- [1] Cetica P., Esposito M.A. (1995) - *La tecnologia dei sistemi informativi ambientali per il controllo della sostenibilità*. Sta in: Florence International Conference for Teachers of Architecture, 28-30 Sept.
- [2] Esposito M.A. (1995) - *GIS as the Urban Environmental Design Assistant*. Sta in: Advances in cooperative computer-assisted environmental design, Advances in computer base design environment, Baden Baden, vol.8
- [3] Esposito M.A. (1996) - *Optical and Radar merge: Application on Firenze's Urban Environment*, V Congreso de la Asociacion Espanola de Sistemas de Informacion Geografica; Barcelona.
- [4] Esposito M.A. (1997) - *La gestione delle informazioni sull'ambiente urbano*, in PAESAGGIO URBANO, n.2/97, pagg.122-126
- [5] Esposito M.A. (1999) - *Développement soutenable du milieu urbain* - Session 1 report, Parlement Europeen, Bruxelles, 27 maggio.
- [6] Esposito M.A. (2000A) - *GIS-Analysis to show LaCoast data base on European Union coastal zones*, GeoInformatics 2000, ISBN 5751112539. Pagg.320-326
- [7] Esposito M.A. (curated) (2000B) Histocity Book - *The best of 1998-2000 Network Research on: The historical Cities Sustainable Development using GIS*, A-linea Editrice, ISBN 8881251787
- [8] Esposito M.A., Boehner C. (1995) - *Urban green areas coverage in Florence*.
- [9] Esposito M.A., Haastrup P., Boehner C. (1996) - *A Case Study of Florence on the Use of Geographic Information Systems and Remote Sensing for Urban Environmental Management*, Report 16441 CE, ECSC-EC-EAEC Brussels, Luxembourg

- [10] Esposito M.A., Veninata V., Bohner C. (1995A) - *Dati geografici per lo studio d'impatto ambientale del nodo dell'alta velocità di Firenze.*
- [11] Esposito M.A.; Bohner C. (1995B) - *Data integration for Urban Design: a Case Study.* Sta in: From Research to Application through Cooperation, Joint European Conference and Exhibition on Geographical Information, Netherlands Congress Centre The Hague, 26-31 March.
- [12] Esposito M.A.; Bohner C. (1997) - *Gestire l'ambiente urbano*, sta in: Sistema Terra, vol.6, pagg.44-46.
- [13] Loudjani P. (1998) - *LaCoast Project – mapping and statistical analysis report*, JRC, SAI
- [14] Perdigão V., Annoni A. (1997) - *Technical and methodological guide for updating CORINE Land Cover database*, joint JRC, EEA publication, EUR17288EN

CAPO MELE: A STORY-TELLING EXPERIMENTAL BEACH IN LAIGUEGLIA (SV)

Adriana Ghersi

University of Genoa, Architecture and Design Department (DAD), Stradone S. Agostino, 37,
16123 Genoa, Italy, phone: +39 349 0544438, e-mail: adriana.ghersi@unige.it

Abstract – The transformation of the coastal landscape assumes today a significant importance, as far as global changes and erosion risks are concerned. The experience at Capo Mele to stage a new approach to the beach, managed by a smart private agent, allows more readings and new possible strategic actions.

The initiative promotes the beach area as a real active museum¹, a particular place for testing and monitoring new mechanisms for the use, protection and narration of landscape values, in the various aspects of adaptability, socio-cultural development and enhancement of the potential of the beach as a treasure chest of biodiversity.

The project aims at finding replicable solutions to give an operational response, through the landscape, to the themes of redevelopment, resilience and sustainability, by narrative and experiential forms that respond to the continuous evolution of this particular place of interface between the sea and the earth.

The reference for the project is related to the idea of the "*jardin en mouvement*", by Gilles Clément² [5], finding a dialogue between the action of the sea and the rearrangement of the beach, on which each season brings new elements. In the rhythm of erosion, transport, reconstruction and redesign of possible spaces for different activities, the beach always suggests new models of use, shared by tourists, visitors and inhabitants.

Thanks to Livio Lovisoni's impulse, the project involves several Universities³, the CNR, the private Capo Mele beach (Laigueglia-SV), the Association "Flowers of the beach" (Alassio-SV) and the Cooperative "Beaches 4.0" (Ceriale-SV). It identifies a series of research-actions ranging from the sowing of "sand flowers" (especially halophyte psammophilous dunals) to the reading and re-use of corroded and consumed woods brought by the sea, from the study of the transformation of the beach. It also concerns the photos by wave watchers, the testimonies of travels, memories, artifacts, symbols and myths, legends and literature, to find new ways of enhancing material and immaterial resources, between private companies and applied interdisciplinary research.

It deals with a series of micro-interventions, real activators of attention, for a wide audience, which can be attracted in a new way to enjoy the beach, proposing different

¹ Mu"SEO" (Museum as Search Engine Optimization).

² Gilles Clément's work refers to the experience of the gardener who tries to accommodate the transformations that nature brings from one season to another. It is about a continuous dialogue between the natural form, the natural spreading of plants and the shape of the garden led by man, through the observation and knowledge of the species, building a relationship with the natural environment by making well-defined choices, staging the encounter/clash between the informal garden and natural expansion and competition between plants. The resulting style is characterized by a representation of spontaneity that arises from a deep knowledge of natural phenomena.

³ Universities of Genoa (DAD and DISTAV), Florence (DAGRI), Padoa (TESAF) and CNR (IVALSA).

recreational activities and cultural hints, for a reflection on the dynamics of coasts and their sensitive and eco-sustainable management.

The research also addresses new management models of state-owned spaces, proposing activities in different seasons and cultural events open to a wider public, promoting the role of the private manager as a qualifying actor, within a larger enhancement project to be shared with the inhabitants and the public administrators.

Enhancement and innovation strategies for beach tourism

The beach is a particular changing interface, between land and sea, in a continuous evolution. Man has often built artificial margins and rigid structures to stabilize the contact with water, producing a progressive artificialisation of the coasts and completely reducing or eliminating the natural elements [9] of the micro ecosystems that manage to survive in this transforming space.

The Ligurian hinterland has already begun to respond to environmental emergencies, proposing forms of tourism [3] and development related to the short chain, sustainability, outdoor tourism and environmental values. The "Un fiore di Spiaggia" project intends to promote this process also in beaches and seaside tourism, where this evolution seems to be slower and more fragmented, changing the perception of the beach-space as a new landscape [6].

The studied beach is located on the Ligurian Western Riviera, within the Gulf of Alassio and at the foot of the rocky promontory of Capo Mele. On the edge of the town of Laigueglia (one of the most beautiful villages in Italy), in the province of Savona, the beach occupies a particularly happy position, overlooking one of the most pristine stretches of sea on the Ligurian coast and surrounded by a secular pine forest. The western side of the promontory is extremely anthropized, the historical village of Colla Micheri is above.

The work on Capo Mele beach, which Livio Lovisone has been carrying out since 2004, involving associations and researchers, expresses the desire to find a new balance, introducing beach usage models that distance themselves from quantitative maximization, to propose new quality systems. The peculiarities of the sites are highlighted, in order to enhance a landscape, by identifying the beach area as a "perceived" place, a special landscape⁴.

The research that is experimented year by year on Capo Mele beach is a reference and a model for a new approach and an innovative new use of the beach, which turns into an open-air museum [4], an oasis of biodiversity, a welcoming meeting place [18] to discuss about the continuous transformation of the coastal landscape. Through the insertion of vegetation, a relationship with the naturalness of the coastal environment is re-built, filtered by an approach that aims at a renewed socio-cultural resilience [13].

At the time of the crisis due to the pandemic of COVID-19, Capo Mele beach is already suitable⁵ for offering situations of social distancing in a context that is rich in artistic and cultural contents.

⁴ See the European Landscape Convention (ETS 176, 2000) and the definition of Landscape as an area, "as perceived by people", whose character is the result of the action and interaction of natural and/or human factors (www.coe.int).

⁵ The beach is organized with adequate surfaces for each parasol umbrella, at least 10.5 m², as required by the Ministry's provisions for summer 2020. The most requested space is called "dune", which reaches 28 m².

New generation beaches

The research project works on a natural area in close contact with the urban one, which over time has seen a strong negative presence of man. The main intent is to bring nature back to the center, promoting a collaboration between man and nature that aims at the protection and conservation of the natural environment, proposing the reconstruction and care of nature niches [11] within a bathing establishment.

In the existent microenvironments, a naturalization work is carried out, by the “Fiori di Spiaggia” Association, using psammophilous protected species (the "sand plants") and other typical Mediterranean plants, located on the slope above the public promenade. The Legambiente award-winning Capo Mele Beach is the protagonist of good practices, active for years on the front of the protection and regeneration of the original ecosystem of the beach and the innovation of its offer. The proposed model guarantees sustainable, innovative and involving management [17] - and fruition - of the natural patrimony of the beach.

It is a process of building a first museum of the beach area and its landscape value, which is proposed as an opportunity for environmental education and understanding of the climate changes that redefine its boundaries.

The peculiarities of a precarious place between sea and earth are told with generative strategies with replicable solutions, which find an operational response in the landscape in terms of requalification, resilience and sustainability management [14], experimenting new narrative and experiential forms, searching the true spirit of the place.

An interdisciplinary meeting between culture and business integrated with university research on different topics with a series of particular focuses for sustainable development: multidisciplinary cross-over experiments that try to provide answers to expectations and needs related to ongoing changes in this important sector of the seaside tourism supply chain. Revitalization and diversification actions of a mature product through facilitated experiences, to help people to understand, without getting bored, through free approaches and paths, designed to be absorbed by the environment and arouse interest and immediate reactions.

Not a traditional museum, with a mere display of pieces, but flowers of the beach [1], sand, sun and salt and a Mu"SEO" or a project-process that implements various actions and activities carried out to improve the visibility of a site and the perception of the beach space, through a multi-disciplinary narrative, which is divided between information, sensations and symbols. It is the proposal of an experience, which, through perceptions and intuition, manages to communicate the identity of the site [7]. The environmental diversity of these places and the uniqueness of this strip of territory are studied, narrating their material and immaterial magic, through the protection of the landscape and the microenvironments that are created, following their natural movement.

More than 20 protected species of Psammophile (sand plants) have been planted and preserved in the concession area of Capo Mele Beach, as well as a manifold variety of other valuable Mediterranean species [15], such as the *asphodel* (*Asphodelus fistulosus*), the rocket sea (*Cakile maritima*), the hare's tail (*Lagurus ovatus*), the lobularia (*Lobularia maritima*), the Cali herb (*Salsola kali*), the sea fennel (*Crithmum maritimum*), the beach poppy (*Glaucium flavum*) [16]. Among these, the Sea Lily⁶ is an endemic species [8], now practically extinct due

⁶ The *Pancratium maritimum* L., is a bulbous plant of the Amaryllidaceae family, which grows spontaneously on the sandy shores of the Mediterranean and Black Seas, which blooms between mid-July

to the transformations of the coastal environment and the progressive disappearance of the sand dunes management [10, 12], a situation that has prompted the European Union to issue a specific directive (43/92/EEC 2110 and 2210) aimed at safeguarding this species.



Figure 1 - A panel about the sand flowers, in Capo Mele beach, photo by A. Ghersi.

Some woods that land on the beach during the storm surges (called "stracqui", in local dialect) underline the natural image of the beach together with the presence of plants. Others become objects of artistic or reuse activities [2], as protection of the plants themselves, or they become study and research material, as for the analysis by the CNR Ivalsa on the species and the age of the different types of wood that have come to Capo Mele from distant places.

The resilience of these environments was severely tested during the perfect storm of 2018, which damaged many structures, but thanks to the ability to resist of some plants and the energy of the involved associations, the beach mu"SEO" was rebuilt, finding also new forms. A series of stories can be told, with the images of the historical storms, with the reinterpretation of myths and symbols⁷.

and late August. Its beautiful flower, white and fragrant, through entomophilic pollination, produces a corky and very light capsule, containing many black seeds, which allows the seed to float, for hydrocora dissemination (adopted by few other species). The waves of the sea collect the seeds scattered around the plant and disseminate them, thanks to the currents, in other points of the coast, favoring the dissemination in new territories.

⁷ A totem recalls the adventure on the Kon-Tiki raft, towards Polynesia, by the explorer Thor Heyerdal, who in the last years of his life lived in Colla Micheri, the delightful historic village that is located in the promontory just above Capo Mele beach.

In a real open-air laboratory, it is possible to take advantage of a series of intelligent services, which offer different activities, from scientific observation to cultural event. Much attention is paid to people's needs, and to the accessibility for all, as dogs are welcomed, in an appropriate area. The time spent on the beach is amplified and welcomes activities also in the evening hours, and even proposals for not bathing seasons, in a new perspective of beach tourism which aims at the seasonal adjustment and the involvement of local actors.



Figure 2 - Capo Mele beach in Autumn, photo by L. Lovisone.

Moving towards a landscape network

The project that concerns Capo Mele beach reveals a series of positive interactions that develop starting from the insertion of plants in the particular amphibious space between sea and land, which the beach represents.

It is indeed important to underline how giving space to plants allows more interesting and stimulating social relationships.

The continuous dynamic invention of new forms of the beach use gives opportunities to a differentiate kind of visitors. It focus on the healthiness of the time on the beach, as a relaxing mental and physical purification.

A sensible attention is skilled to differentiate the services with respect to the main clusters of users. From very colorful panels, with short texts for children and school groups, to the implementation of a path for the disabled. For a continuous updating and improvement of the offer, there will be new multimedia and interactive environments provided to immerse visitors in a "journey in feelings and emotions" to involve them in an experience that will intercept all five senses and the sphere of imagination.

Following the rules of the experiential marketing, it seeks to provide its visitors a unique, exciting and unforgettable experience, in order to encourage the reception of the conveyed messages and the formation of a lasting memory, thus increasing the behavioral and mental "brand loyalty" in a life time value perspective.

The experimentation of enrichment of the experiential offer that is proposed to the visitor, through the story, the contextualization of the mu"SEO" becomes an operating model that can be replicated, spreading, like the sea lily seeds, in other beaches.

The winning element is the "multidisciplinary" nature of this place, which manages to narrate the intercultural and inter-sectoral stratifications creating a strong identity, which enhances the environmental diversity and uniqueness of this strip of territory.

The Mu"SEO" makes visible the values of the beach; promotes knowledge and use; transmits messages and information; creates relationship among existing resources; diversifies the offer of initiatives; develops the collective memory of a community that takes care of a landscape. The visit path has one free and naturalistic scheme and is organized to prepare the visitor for proposals and various didactic activities.

The project is a very important tool also to strengthen the relationships between companies, institutions and other local or broader actors, starting with cultural and tourist operators. The company's activity in the area and its commitment also in the cultural sphere, contributes to increase visibility and obtain increasing support by all stakeholders and, in particular, by the political-institutional actors, which greatly affects the company's activities especially by virtue of authorizations of various kinds.

The main ambition of the project is to become a model, that can be diffused and change the approach to the coastal environments. The team of researchers and stakeholders can work on its expansion, as, for example, in the public under-utilized beach that is in connection with the beach under concession of Capo Mele, enlarging the cultural botanic insertion of the sand flowers also in other green areas along the Laigueglia promenade, working together with the Municipality of Laigueglia. The network of associations, private investors, public administrators can empower the project, under the monitoring by the Universities and the researchers, reaching a wider territory, enhancing the idea of the sand flowers as iconic reference of the entire Gulf of Laigueglia, in a more articulated system of different actions, to enhance the values of the whole landscape contest.

The extension of the model to a wider territorial area of reference, together with other private and public subjects, could highlight the value of the entire environmental landscape system as an economic and cultural resource, aimed at a wider number of users, from adults to children, from local inhabitants to tourists.



Figure 3 - The beach and the pine forest on the steep slope at the back, photo by L. Lovisone.

References

- [1] Alberti M. (2008) - *Fiori del mare in Liguria*, Amadeo, Chiusanico.
- [2] Baratta A. M., Catalano A. (2015) – *Il riciclaggio come pratica virtuosa per il progetto sostenibile*, Ets, Pisa.
- [3] Calcagno Maniglio A. (ed.) (2009) - *Paesaggio costiero, sviluppo sostenibile*, Gangemi, Roma.

- [4] Cherubini P. (2001) - *Un archivio naturale*, in *Le Scienze dossier: il clima che cambia*, n.5, ago, pp.86-87.
- [5] Clément G. (1991) - *Le jardin en mouvement*, Pandora, Paris.
- [6] De Poli M., Incerti G. (2014) – *Atlante dei paesaggi riciclati*, Skira, Milano.
- [7] Gaggero G., Ghersi A. (eds.) (2002) - *Il paesaggio di Ventimiglia e Bordighera. Percezione, identità, progetto*, Alinea, Firenze.
- [8] Grassi F., Cazzaniga E., Minuto L., Peccenini S., Barberis G., Basso B., (2005) - *Evaluation of biodiversity and conservation strategies in *Pancratium maritimum* L. for the Northern Tyrrhenian Sea*, in *Biodiversity & Conservation*, vol. 14, n. 9, pp. 2159–2169.
- [9] Hajek I., Hammam P., Lévy J.P. (2015) - *De la ville durable à la nature en ville. Entre homogénéité urbaine et contrôle social. Regards croisés nord-sud*, Presse universitaire du septentrion, Lille.
- [10] ISPRA (2015) - *Gli habitat delle coste sabbiose italiane: ecologia e problematiche di conservazione*, Rapporto 215/15.
- [11] Jones C.G., Lawton J.H., Shachak M. (1994) - *Organisms as ecosystem engineers*, *Oikos* 69, pp. 373-386.
- [12] Pignatti S. (1993) - *Dry coastal ecosystems of Italy*, in: Van der Maarel E. (Ed.), *Dry coastal ecosystems. Ecosystems of the world*, Elsevier: pp. 379-390.
- [13] Robert S., Melin H. (eds) (2016) - *Habiter le littoral. Enjeux contemporains*. Aix-en-Provence : Presses universitaires de Provence et Presses Universitaires d'Aix-Marseille.
- [14] Romano B., Zullo F. (2014) - *The urban transformation of Italy's Adriatic coastal strip. Fifty years of unsustainability*, *Land Use Policy*, (38), pp. 26-36.
- [15] Vagge I., Biondi E. (1999) - *La vegetazione delle coste sabbiose del Tirreno settentrionale italiano*, *Fitosociologia* 36: 61-95.
- [16] Vaglio M. (2013) – *Erbe da mangiare e da bere in Liguria*, Atene, Arma di Taggia.
- [17] Vallega A. (1999) - *Fundamentals of Integrated Coastal Management*, Kluwer, Dordrecht.
- [18] Viard J. (2000) - *Court traité sur les vacances, les voyages et l'hospitalité des lieux*, L'Aube, Paris.

THE COASTAL LAKES OF CAMPI FLEGREI: BETWEEN BIODIVERSITY AND ANTHROPIZATION

Gabriella Nora Maria Giudici¹, Ferdinando Jannuzzi²,
Salvatore Patrizio³, Fabrizio Pisani Massamormile⁴

¹Agronoma, Pozzuoli (NA)

²Architetto-Componente del Consiglio Regionale ADSI Campania

³C.N.R. – Istituto di Ricerca sugli Ecosistemi Terrestri – UOS di Napoli

Tel. 0816132321, e-mail: salvatore.patrizio@cnr.it

⁴Geologo-Presidente dell'Associazione Culturale Napolifuocoemare

Abstract – Campi Flegrei (from Greek *phlegraios* = burning) is a volcanic area north west of Naples, extended from Agnano crater until Cuma. Pozzuoli, Bacoli, Monte di Procida e Quarto, some northern neighborhoods of Naples. In this area there are three coastal lakes: Fusaro, Miseno, Lucrino. Our study analyses geomorphological, botanical, historical and anthropic features of their ecosystems.

Fusaro lake, between Cuma and Monte di Procida, in the Bacoli administration, is the largest in surface area (1 km²). A coastal dune with maquis is between the lake and the sea, exchanging water through three channels. It has a volcanic origin and a smaller basin size than the original crater because of the sea level rise. There are still fumaroles and gas emissions, while thermal water was discovered in the '60s.

Nearby, between Monte di Procida and Capo Miseno, there is lake Miseno (also called dead sea), it was formed by the sea over-washing inside an inactive volcanic crater, separated from the sea by the later emersion of a submerged dune. Its current size is 0,4 km², its average depth is 2,25 m and it is connected to the sea by two estuaries.

Lucrino lake measures less than 0,7 km², is connected to the sea through a 1,5 m wide channel. It is under the city of Pozzuoli administration between Averno lake, Monte Nuovo and the Stufe di Nerone spa.

Depending in formation and shaping by the Campi Flegrei caldera, it shows secondary volcanic phenomena dating back to roman time when Virgilio described sulfur boiling in it.

All together they form a lake-net very important for migrating and resident birds and the conservation of the flora of wet areas. Their uncommon conditions create numerous microenvironments, some harsh, determining plants communities. Some lake biosystems prolong into the coastal systems.

Introduction

The lakes in this study are included in the crater field of the Campi Flegrei, a large quiescent volcano that has produced numerous different eruptive centers for 39 000 years to date.

The term Campi Flegrei (from the Greek *phlegraios* = burning) indicates an area of the province of Naples from the Posillipo hill to Cuma.

The ecological importance of the three lakes is evident by their being listed among the European Sites of Community Importance (Lago Fusaro IT8030015, Lago Lucrino IT8030016, Lago Miseno IT8030017). In addition, they are close or connected with other areas of high natural value (Lago d'Averno IT8030014, Cuma forest and Montenuovo protected area). All together they include 16 species and 8 habitats listed in the Habitat Directive [1].

They all differ by their hydrologic conditions and the status of their banks: lakes Fusaro and Lucrino had part of their shores cemented from a long time; lake Fusaro because of an old embankment, right in front of the Casina Vanvitelliana and lake Lucrino because of a terrace joined to a restaurant from the beginning of last century. Lake Miseno has not proper embankment or terraces but does not show the proper riparian zone anymore for a relevant portion of its shore. None of the lakes still retains the richness of species they experienced in the past. However even though many studies have been carried out on these lakes, still little is known about the current loss from the flora and fauna they were hosting in their pristine natural conditions.

Materials and methods

Lake Lucrino was a large bay that in the 1st century BC was transformed by an isthmus in a lake, in order to provide a safe harbour to the Roman fleet. It is fed today by a small thermal spring, currently exploited for tourism, in south-west, at the foot of Monte delle Ginestre.

The depth is rather low and strongly influenced by the oscillations of Phlegraean bradyseism, so that, since Roman times, the isthmus has had to be raised more than once. The documented period of maximum submergence was between the ninth and fourteenth centuries, when the effects of the sea storms reached the lake Averno more inland. The lake was named after *lucrum* because of the flourishing fisheries in Roman times. His fame grew in 37 BC. when Marco Vipsanio Agrippa, during the war between Ottaviano and Sesto Pompeo, created an imposing military port: Portus Julius, in honor of Gaius Julius Caesar Octavian. The construction works were entrusted to the architect Lucio Cocceio Aucto. In ancient times, the port was defended by a long dam thrown onto the beach, which starting from the Punta dell'Epitaffio joined Punta Caruso, on which the Via Herculeana passed. A canal opened in the dam allowing ships to enter the Lucrino basin from which, with another rock-dugged canal, they moved to the lake of Averno, which served as a dry dock.

The port was short-lived as the basin, being shallow and subject to silt up, became unsuitable for heavy Roman warships. For this reason, about a quarter of a century later, it was abandoned as a military port but continued to live for a long time as a port for civil and commercial purposes. Due to bradyseism and the retreat of the coast line, Portus Julius was abandoned at the end of the fourth century.

The volcanic origin of Lake Miseno does not appear immediately evident because of its irregular shape, included in a complex crater system between the eruptive mouths of Capo Miseno, Bacoli and Punta Pennata, active between 35 thousand and 10 thousand years ago.

The lake is named after Miseno, trumpeter of Aeneas's Trojan army (Aeneid - Virgil - book VI). He dared to challenge in a trumpet contest Triton (son of the sea god Poseidon); the latter, took offence and drowned him [2].

Legend has it that Enea, having found the body, buried it under a huge mound, Capo Miseno, whose square shape reminds that of a gigantic tomb.

At the end of the 1st century B.C. the Roman general Agrippa preferred it to the *Portus Julius* and transferred the Roman fleet to Miseno. Soon lake Miseno became the most important military harbour of the Roman imperial fleet (*Classis Misenensis*). The *Portus Misenum* was formed by two natural basins: the lake part was used for the construction and repair of ships while the bay was the actual port. To supply the numerous ships with water, one of the largest cisterns was dugged in the tuff of the hill, later called *Piscina mirabilis*, collecting water from Augustan aqueduct [3].

Lake Fusaro is erroneously classified as a lagoon lake, but, geologically, it has a sulphureous volcanic origin, with about half of the crater now occupied by the coastal bar and marine waters.

The term Fusaro derives from the hemp maceration carried out in the Angevin era, because the basins for this activity were called *fusari*, from the Latin *fundere*, *fusum*, to dissolve [4].

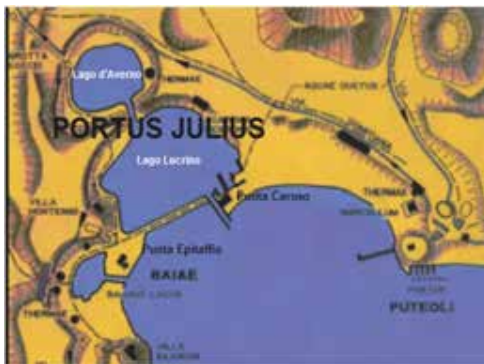

Figure 1 - *Portus Julius*.



Figure 2 - *Portus Misenum*.



Figure 3 - *Piscina Mirabilis*.



Figure 4 - *Casina Vanvitelliana*.

The area was marshy and sparsely populated, in the myth the lake was identified with the *Acherusia palus*, the infernal marsh formed by the Acheron river. On the other hand, the area was very rich in game so that, it become from 1752, a hunting and fishing reserve of the Bourbons who entrusted Luigi Vanvitelli with the first works for the transformation of the place. King Ferdinand IV of Bourbon (later Ferdinand I of the Two Sicilies) entrusted the completion of the work to Carlo Vanvitelli, son of the late Luigi, who in 1782 built, on an existing island, an elegant hunting and fishing casino known today as *Casina Vanvitelliana* [5].

The area around the Fusaro Lucrino and Miseno lakes, once a mainly agricultural territory inhabited by peasants and, along the coast by fishermen, had an extremely low building-density consisting mainly of rural houses inside small farms; small well-camouflaged houses in an extremely fertile area, rich in agricultural and spontaneous vegetation, that gave the environment a connotation almost unchanged for centuries; few larger than three-room buildings belonged to the wealthiest class and were located in dominant positions on the territory. For all of them local materials were used, mainly tuff, of which the area is rich, and the classic mortar with binder. Sometimes different techniques were used, well-cut tuff wall faces containing tuff debris and mortar when stronger structures were needed, usually in multi-story buildings. This practice, after several centuries, was disastrously altered after the middle of the 900, when even in those areas, the use of reinforced concrete became widespread for any building. Then new buildings were created to satisfy industrial use which should not have been meant for this area. Constructions have piled up without any order, any aesthetic and functional sense, consuming without any logic a territory once in perfect balance.



Figure 5 - Miseno Lake 1959.



Figure 6 - Miseno Lake 2020.

Few and not easily recognizable traces of a once unique and unrepeatably territory, only a few noticeable buildings could still be found inside a too dense mass of modern buildings, few exceptions like the Casina Vanvitelliana on the lake Fusaro or some ancient building on the edge of the hills or in the villages historical centers.

The three lakes, apart from their origins can be considered coastal lagoons; they have shallow water with salinity and volume different among them; more important they are separated from the coast by banks of sand or shingle or rocks (in their original condition). The natural continuity with the sea-shore environment is currently impaired in various degrees: the most dramatic one is apparent in lake Lucrino, secluded by the sea by one road, a railway and the sea cabins built for tourism at the beginning of the last century.

The lake Fusaro has got a differently wide expanse of vegetation, corresponding to old consolidated dunes, now small orchards, a road and a trenched railway separating it from the sea-shore (where, apart from the beach installations, dunes could still be seen in places). The lake Miseno has the less compromised condition, but still a road, parking lots and beach cabins are barriers to the ecological continuity between the lake and the sea-shore. The most obvious loss of all three lakes is the loss/big reduction of the riparian zone and the altered status of the natural water ways. Riparian zones have high ecological values in all water bodies: they provide filters for materials in and out, chemicals processing (both pollutants and nutrients), food and shelter for widely different species of aquatic and terrestrial environment, they regulate the water flows (from water bodies, rain and run off), provide a barrier to the erosion and facilitate the transition among ecosystems typical of wet zones; they are driving factors of biodiversity. The hydrological system provides the main character of a water body, setting it as a pond, a lake, a running water system, furthermore it determines the turnover of nutrients by the water circulation and the temperature. The alteration of water fluxes determines adjustments to new balances whose results are not often valuable from the ecological point of view.

Results and discussion

Current morphology of Lake Lucrino was built in 1538, after the eruption of Monte Nuovo which delimited the boundaries of the lake towards the north-east, definitively isolating it from Lake Averno [6]. Until then the area was home to numerous thermal springs, called *Balneum*, such as Ciceronis, Tripergula, Arcus and others, the most important of which was the Sudatorium Triuli, located in the hill of Tritoli, south-east of the current lake.

The connection with the sea is ensured by a narrow passage located in the north-east area, currently confined, both laterally and above, by a reinforced concrete structure. Right in this area there is the lowest depth, in the order of tens of centimeters, with occasionally formation of sandy islands, generated by the scarce movement water.

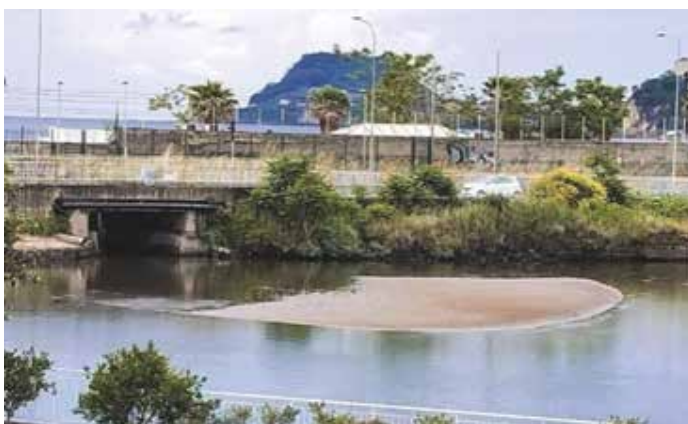

Figure 7 - Mouth of Lucrino Lake - Sandy island emergence in May 2020.

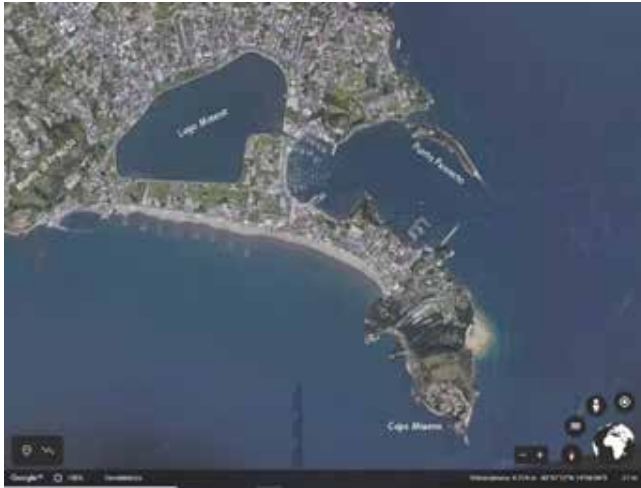

Figure 8 - Miseno Lake.

Initially the area of Lake Miseno was swampy but marine sedimentation subsequently isolated the lake from the sea, with the formation of the large beach, today the site of mainly touristic and agricultural activities, between Monte di Procida, Capo Miseno and Bacoli.

The lake depth could reach 4 meters and two mouths ensure a good exchange with the sea, but the great anthropogenic pressure and unauthorized use produce intense pollution making mussel farming impossible.

Currently in the area of Lake Fusaro there are fumarolic exhalations on the hills to the north-east, in the locality Mofeta, as well as from groundwater flowing about 40÷50 meters below the lake, to south-west. In the past, however, the volcanic manifestations had to be much more evident, as reported by writings of the third century B.C. [7].

The lake bottom has always been quite low, since Greek times when the lake was looking as a large bay that broke the linearity of the sandy coast. Geologically it is not possible to identify the period in which the coastal dune was formed, but analyzing the writings of Strabo and Seneca, it can be deduced that the isolation of the lake from the sea began, probably between 20 and 60 A.D. The whole area has always been influenced by Phlegraean bradyseism, certainly starting from the second century A.D., as evidenced by the archaeological remains currently submerged, dating back to that time.

Current conditions of the lakes are showing loss in biodiversity although a detailed up-to-date scientific assessment has not been carried out. In Natura 2000 dataforms most recent assessments dates back to 2013 and lack of site management is reported [8].

However, public administrations are often lazy and careless in paperwork and do not update informative sheets; this is the case of the Averno lake for which a nature path has been provided with informative panels but nothing of it is showed in Natura 2000 dataforms [9]. For lake Miseno the shore pathway has been hindered for the last two decades and now a complete circuit pathway is under construction. But still no plan is mentioned for any of them. A survey on the coastal dunes should be carried out because they should be the natural prosecution of these lake environments [10]. Unfortunately, the

dunal ecosystem innot properly protected nor integrated in the overdeveloped beach tourism [11]. Perspective transect have been sampled on lake shores: on Lucrino lake the bestpreservedriparian zone is the western area near the spa Stufe di Nerone. On the narrow strip of vegetation a few typical species were found along with secondary colonization of *Rubus* spp. signal of anthropic degradation. Nearby small patches of *phragmites australis* are still offering shelter to grebes and coots whose major site is the near Averno lake. The same transect in some of thebetter-preservedriparian zones of Averno lake showed more than 6 species native of the lake-shore. Sampling on the Fusaro shore was not done because of the restricted area all in private property, nor along the Miseno lake because of the parking lot use. Springtime sampling was impossible because of the Pandemia restrictions.



Figure 9 - Fusaro Lake. In red the hypothetical original form of the crater.

Conclusions

Restauration of natural ecosystems and cultural landscape are imperative for the survival of this area. The approach to restauration, to be effective, must be an integrated one, all features of territory promotion should be considered to further high-quality tourism and better environment and life quality of residents, environmental conservation in both nature and culture features, economics improvement. Stakeholders should be involved in the process, without whom any restauration policy would be ineffective. Actions to be taken are:

Hydrogeological actions for natural water flow recovery:

In the lake Lucrino the dredging of the lake bottom, in particular in the mouth area is of utmost importance to ensure the quality of the water.

The three canals that connect Lake Fusaro to the sea have an average depth of 1 meter today and do not always ensure the right flow to the sea, also due to the presence of debris; therefore, an intervention is necessary to restore the full functionality of the mouths.

In the lake Miseno appears to be significant in the recovery of the ancient hyper chlorinated-sodium thermal springs used until the years preceding the Second World War.

Nature conservation measures:

Current status assessment: riparian ecosystem and ecotones, anthropogenic disturbances (soil use, water use/waste, water chemicals and ecological quality).

Restoration actions: restoration of riparian zone, riparian range, water quality development to a healthy state (wastewater control and treatment), agriculture environment-friendly techniques and waste control. It is noticeable that, apart from other kinds of protection, restoration of riparian zone is compulsory by the art. 15 d.lgs. n. 152, 2006 (T.U. ambiente).



Figure 10, 11 - Fusaro Lake: to the left waste water pipe, to the right tyres store on the lakeshore.

Landscape protection and restauration

It is late to stop the architectural degradation which has occurred in the last decades, but it is still possible to impose regulation on the keeping of the building and on the conservation of land uses in unoccupied areas; and it is particularly important to preserve.



Figure 12, 13 - Averno lake: traditional agriculture landscape.

Acknowledgments

Work carried out with the contribution of the Rotary Club Naples Castel Sant'Elmo and with the patronage of the Italian Historic Houses Association - Section Campania.

References

- [1] Council Directive 92/43/EEC 1992
- [2] Virgilio (2001) - *Eneide* (translation by Ramous M.), 1st ed., Marsilio Editori, Venice.
- [3] <http://www.cnrweb.tv/viaggio-nel-sottosuolo-di-napoli/> (Varriale R. – CNR/ISMed)
- [4] Patrizio S. (2011) - *I laghi dei Campi Flegrei: dalla Casina Vanvitelliana all'Antro degli Inferi*, Special Magazine, Arpa Campania Ambiente n. 2, 48 – 49
- [5] <https://parcodeicampiflegrei.it/27-conoscere-il-parco/siti-naturalistici-e-paesaggistici/aree-del-parco/46-laghi-fusaro-lucrino-miseno.html>
- [6] <http://www.ingv.it/it/>
- [7] <http://www.distar.unina.it/it/vulcani-napoletani/campi-flegrei>
- [8] Nature 2000 dataform IT8030015, Nature 2000 dataform IT8030016, Nature 2000 dataform IT8030017
- [9] Nature 2000 dataform IT8030014
- [10] Nature 2000 dataform IT8030015
- [11] Balestieri R., Giudici G.N.M. (2017) - *Modello di promozione gestionale del paesaggio costiero per la valorizzazione della qualità ambientale ai fini di un turismo di fascia alta e sostenibile*; Sixth International Symposium. Monitoring of Mediterranean Coastal Areas: problems and Measurement Techniques: Livorno (Italy) September 28-29, 2016 / edited by Claudio Conese. – Firenze: Firenze University Press

THE MANAGEMENT OF DREDGED MATERIALS: THE «LONG AND WINDING ROAD» FROM WASTE TO RESOURCE

Ilaria Lolli

Università di Pisa – Dipartimento di Giurisprudenza,
Via Curtatone e Montanara, 16 – 56126 Pisa (Italy)
Tel. 050 2218800, e-mail ilaria.lolli@unipi.it

Abstract – The removal of material from the seabed and from the bottom of brackish bodies of water is necessary to maintain downflow conditions, to ensure navigability and port accessibility, to collect sands for coastal nourishment, to guarantee coastal protection, to help habitat development or enhancement, to pick contaminated sediments up, to promote land reclamation. And examples could go on.

However, both the dredging operations and the management of the resulting materials have the potential to cause relevant damages to the environment, especially in coastal and marine contexts, where ecosystems are fragile and vulnerable.

Dredged materials, in particular, have been considered for a very long time nothing more than a waste meant for disposal. Now the time has come to move from the ‘disposal approach’ to the ‘waste recovery’ or, even better, to the ‘waste can be a non-waste’ ones.

Unfortunately, the management of dredged materials reveals itself as committed to a congeries of rules, which build up a framework of law that appears plainly fragmentary and incoherent. The road is still long (and winding).

1. The management of dredged materials as waste

In principle, unless they can be considered by-products, dredged materials should be treated as special wastes, classified, according to the European List of Waste (LoW)¹, under mirror entries 17 05 05* (dredging spoil containing hazardous substances) and 17 05 06 (dredging spoil other than those mentioned in 17 05 05).

With those being mirror voice, according to the Directive 2008/98/EC (Waste Framework Directive), it will be necessary to classify the waste (i.e. to assign the appropriate codes for the waste class and the hazard category and those for the hazard listing) according to the Regulation (EC) 1272/2008 (CLP) on classification, labelling and packaging of substances and mixtures.

The existence of hazardous features or the presence of hazardous substances – and the consequent assignment of a hazard property code ranging between HP1 to HP15 – will therefore have to be evaluated according to the Annex III to Directive 2008/98/EC, as amended by Regulation (EU) 1357/2014 and by Regulation (EU) 2017/997 (as regards the hazardous property HP 14 Ecotoxic). The procedure is different for persistent organic pollutant (POPs), whose presence, according to the 2014/955/CE decision, should be verified

¹ Commission Decision 2000/532/EC, as amended by Commission Decision 2014/955/EU, and Annex III to Directive 2008/98/EC

and quantified according to the Regulation (EU) 2019/1021, which recast Regulation (EC) 850/2004².

One of the most relevant issues regarding mirror voices is the one regarding the range of compounds to be identified and quantified to ascertain the potential hazardousness of the waste. The selection of the range is especially complex for dredged materials, whose composition is not known *a priori*, by virtue of the origin and the nature of the material not being traceable to a specific activity or production process.

In fact, it is apparent that the only solution is to perform a physical and chemical analysis of the excavated material. Nevertheless, the analysis might not be conclusive since, for certain substances, the current analytical techniques only allow to detect and quantify the elements (e.g. metals) and certain chemical species (e.g. cations and anions) which are present in the material rather than providing direct information on the compounds which they form³.

Under the premise that, as the Commission notice (2018) (point 4.2.1 of Annex 4) states, the substances for each identified element should be determined according to the «least favourable realistic scenario», it becomes necessary to clarify whether, for the purposes of waste classification, it is necessary to verify the absence of any hazardous substance (the so-called *safety* or *presumed hazardousness* theory, based on the precautionary principle) or if the analytical characterisation could be limited to the substances which, with a high degree of probability, might be present in the waste (the so-called *probability* theory, based on the sustainable development principle).

The Commission notice (2018) already pointed out that «*those classifying the waste are expected to take all reasonable steps to determine the composition and hazardous properties of the waste*» (cf. point 3.2.1).

More recently, the Judgement of the Court of Justice (Tenth Chamber) of 28 March 2019 in Joined Cases C-487/17 to C-489/17 appears to have finally offered a decisive contribution, although the Italian doctrine still exhibits some uncertainties⁴.

Much in brief, in the opinion of the judges «*the chemical analysis of waste must enable the holder to gain sufficient knowledge of the composition of that waste in order to determine whether the waste has one or more of the hazardous properties [...]. However, no provision of the EU legislation [...] may be interpreted to the effect that the purpose of that analysis is to determine the absence of any hazardous substance in the waste at issue [...]*» (par.45).

² It must be noted that, as recently underlined in the Commission notice on technical guidance on the classification of waste (2018/C 124/01, point 2.1.8), as established in the List of Waste, point 2, third hyphen, the POPs to be considered are the so-called «old POPs» (such as dibenzo-p-dioxins, polychlorinated dibenzofurans, DDT, chlordane, dieldrin, heptachlor, aldrin, etc.); it follows that the hazardousness of the other POPs should be evaluated by applying the concentration limits described in the Annex III to Directive 2008/98/EC.

³ Refer to point 4.2.2 of Annex 4 to Commission notice (2018), which – in certain conditions – excludes further speculation for some elements.

⁴ The Italian *Corte di Cassazione* (Court of Cassation), after referring to the Court of Justice of the EU for a preliminary ruling, has delivered three judgments (Cass. Pen., *sez.III*, 9 ottobre 2019, nn.47288, 47289, 47290). On different positions of commentators – *safety* theory, *probability* theory, ‘intermediate’ theories (*scientific safety* or *mitigated certainty*) – see most recently Losengo R. (2020), *Rifiuti con codici “a specchio”: dopo il vademecum della Cassazione sulla pronuncia pregiudiziale della Corte di Giustizia continua la “guerra d’opinione” sulla classificazione (e si rischia di dimenticare il diritto penale, in RGAonline, (11), 1-8.*

In substance, reading further into the sentence, «*the EU legislature, in the specific area of waste management, intended to strike a balance between, on the one hand, the precautionary principle and, on the other, technical feasibility and economic viability, such that waste holders are not required to ensure that the waste in question is devoid of any hazardous substance, but may confine themselves to ascertaining the substances which may reasonably be found in that waste and assessing its hazardous properties on the basis of calculations or through tests relating to those substances*» (par.59) (emphasis added).

Furthermore, while it's true that waste holders can't be imposed «*unreasonable obligations, both from a technical and from an economic point of view*» – as establishing that there are no hazardous substances in the waste would certainly be – they are nevertheless «*required to look for hazardous substances which may reasonably be found in that waste, and thus, in that respect, [they have] no discretion*» (par.46)⁵.

In application, this time, of the precautionary principle, it follows that, should an assessment of the risks «*as complete as possible having regard to the particular circumstances of the case*» demonstrate that «*it is impossible, in practical terms, for a holder of waste which may be classified under mirror codes to determine the presence of hazardous substances or to assess the hazardous property of that waste*», it should have to «*be classified as hazardous waste*» (par.62).

2. Disposal at sea and in contiguous environments of materials resulting from the excavation of the bottoms of marine or brackish bodies of water (article 109 of Lg.D. n.152/2006 and article 21 of Law n.179/2002)

Article 109 of Lg.D. n.152/2006, with a far from ideal formulation, allows the «*intentional immersion into the sea [...] or in contiguous areas, such as beaches, lagoons and brackish basin beds and coastal embankments*» of, inter alia, «*materials excavated from the bottoms of marine and brackish bodies of water*» (par.1, lett.a).

Article 21 of L. n.179/2002, allows, in turn, beach nourishment operations, as well as the immersion of dredged materials from seabeds or from the bottoms of bodies of brackish water into confined coastal disposal facilities.

First of all, it seems useful to spend some words trying to deepen the definitional framework, particularly with respect to *seabeds* and *brackish basin beds*.

Regarding *seabeds*, it can be useful to recall article 2 of Lg. D. n.190/2010, which, implementing Directive 2008/56/EC (*Marine Strategy Framework Directive*), offers a definition of *marine waters* as «*waters, the seabed and subsoil on the seaward side of the baseline from which the extent of territorial waters is measured extending to the outmost reach of the area where the State has and/or exercises jurisdictional rights, in accordance with the International law of the sea such as the territorial sea, the exclusive economic zone, protected fisheries areas, the continental shelf and, where established, ecological protection zones*».

⁵ As the Commission notice (2018) points out at point 4.2.1 of Annex IV (with the comment appearing well suited to the characterisation of dredged materials), the «*reasonably*» may for example lead to rule out the presence of certain substances because of their physical and chemical properties.

As for *brackish basin beds* («fondali salmastri»), their identification is undoubtedly more complex.

Without a specific definition in terms of regulations, it must be assumed that they are the bottoms of the so-called *transitional waters*, namely, according to Directive 2000/60/EC, «bodies of surface water in the vicinity of river mouths which are partly saline in character as a result of their proximity to coastal waters but which are substantially influenced by freshwater flows» (see also article 54, par.1, and article 74, par.2, of Lg.D. n.152/2006).

This very generic definition has been better specified at point A.4 of Annex 3 to Part III of the Lg. D. n.152/2006, which, after distinguishing between *river mouths* («foci fluviali») and *coastal lagoons* («lagune costiere»), based on the geomorphological characteristics of the waters, designates, according to the different descriptors that may be used (tidal excursion, surface area, salinity), a host of types and subtypes⁶. While the issue would require much deeper consideration, it may still be useful to remind that *brackish coastal lakes* («laghi costieri salmastri»), which fall into the type of the so-called *not-tidal lagoons* («lagune costiere non tidali»), fully belong to the category; on the other hand, *coastal salt ponds* («stagni costieri»), which «owing to intense and prevailing evaporation exhibit greater values of salinity than the neighbouring sea» have been included by virtue of an «operational» – that is, based on conventional and with application in mind – definition of body of transitional water (see point A.4.1).

That said, in implementation of the above mentioned article 109 of the Lg.D. n.152/2006 and article 21 of the Law n.179/2002, the M.D. (Ministerial Decree) n.173/2016 has:

- a) regulated the authorization procedures for the intentional immersion of dredged materials at sea, which fall within the competence of the Regions, with the exception of the immersion inside marine protected areas, reserved to the competence of the Ministry of the Environment, Land and Sea, id est MATTM);
- b) introduced standard criteria with which every Region, with its own rules, should comply in regulating the other authorization procedures; however, no criteria have been established for, inter alia, beach restoration operations («ripristino degli arenili»)⁷ and the movements of dredged materials within a port («spostamenti in ambito portuale»)⁸, which are, in any case, reserved to the competence of Regions.

Dredging activities can be carried out for several purposes. The M.D. expressly mentions the following, although with respect to *seabed* sediments only: maintaining, improving or restoring navigability and port accessibility; reopening of totally or partially obstructed river mouths; realization of infrastructures within port or coastal areas; collecting sand for coastal nourishment (article 2, par.1, lett.e).

⁶ This without prejudice to the possibility, for Regions, to add additional subtypes.

⁷ The activities in question are those which are carried out within a given site following a seasonal pattern or in any case, following sea swells that caused the accumulation of materials and which consist of the levelling of surfaces via the spreading and redistribution of the accumulated sediments across the site itself (article 2, par.1, lett.g).

⁸ That is, the movement of sediments within port areas for the activities of seabed remodelling, so as to ensure the viability of the mooring points, the safety of berthing operations and the restoration of the navigability, in such a way that no sediments are dispersed outside the site of the operations (article 2, par.1, lett.f).

Especially in regard to port areas, it should be recalled that M.D. n.173/2016 expressly encompasses into its application field the management of dredging materials excavated in port areas which are not included in remediation Sites of National Interest (SIN) and of materials which come from a SIN as result of dredging operations within port and marine-coastal areas and are intended to be managed outside the SIN itself (art.1; cf. also article 1 of M.D. n.172/2016, on which see *infra*).

According to M.D. n.173/2016, the disposal routes of the dredged materials are defined after the materials have been characterized by the assignment of a Quality Class (ranging between A and E), resulting from the weighted integration of the ecotoxicological and physico-chemical classifications (cf. point 2.7 of Technical Annex to M.D.). The Quality Class will serve as a basis to define the management operations, which may consist of (cf. point 2.8 and figure 7 of the Technical Annex):

- a) *intentional immersion at sea*, that is (article 2, par.1, lett.b, of the M.D.) at a distance from the coast greater than 3 nautical miles or beyond the bathymetry of 200 meters; it is important to notice that, according to article 4, par.3, of the M.D., this option should be permitted only if beach nourishment or immersion into confined disposal facilities are not viable;
- b) *beach nourishment operations*, that is addition of excavation materials on emerged and/or submerged beach, with priority given to areas subjected to coastal erosion phenomena (article.2, par.1, lett.d);
- c) *immersion into confined disposal facilities* with varying degrees of permeability, both in marine-coastal and port areas, including disposal through capping.

Should none of the aforementioned options be viable because of the quality of dredged materials (Class E), it may be necessary to safely remove the sediments from the marine environment, after a risk assessment has been carried out.

3. Management of materials dredged within remediation Sites of National Interest (article 5-bis of Law n.84/1994)

Unlike dredged materials which originate from within a SIN and are intended to be managed outside the site itself, which as seen above are regulated by M.D. n.173/2016, the management of any other dredged materials within a SIN is specifically regulated by Article 5-*bis* of Law n.84/1994⁹ and its implementing decree, M.D. n.172/2016.

Article 5-*bis* and M.D. n.172/2016 (esp. point 5 of Annex A) regulate the management of the aforementioned materials by providing a set of potential destinations, possibly after recovery operation. These materials may, once characterized (article 2, par.1, of the M.D.):

- a) be dumped or poured into water bodies which they come from; be used for submerged or emerged beach nourishment; be used to shape coastal landscapes; be used to improve the condition of the bottoms via capping, provided that their physical, chemical and microbiological characteristics are analogous to those of the natural background for the site; these conditions may also be met following treatments for the removal (but not for the sole immobilisations) of the pollutants;

⁹ Introduced by Decree Law (D.L.) n.1/2012, converted into Law n.27/2012.

- b) be used on land, provided that their levels of contamination do not exceed those reported in Columns A and B of Table 1 of Annex 5 to Part IV of Lg.D. n.152/2006 (so-called Threshold Concentrations of Contaminants, *Concentrazioni Soglia di Contaminazione*, CSC), with regard to the land-use destination of the site of usage and after a leaching test to assess the conformity of the eluate to the parameters set by M.D. February 5th 1998 (cf. Annex 3)¹⁰; as for the CSC, it is worth noting that in addition to the aforementioned thresholds of Table 1 (public and private green plots and residential for Column A, commercial and industrial for Column B) M.D. n.46/2019 introduced CSC for agriculture areas, filling an obvious gap; it is therefore reasonable to consider that the reference contained in M.D. n.172/2016 should include them as well; conclusively, the environmental performance of the materials may be assessed directly or after treatments having the sole purpose of reducing the salinity of the material or removing (but, again, not immobilising) any pollutants;
- c) be poured into *confined disposal facilities*, provided that they are non-hazardous as they are or as a consequence of treatments for the removal (again, not the sole immobilisation) of pollutants; in this case, the disposal facilities will still have to meet certain requirements in terms of permeability.

4. The movement of sediments into bodies of transitional water according to article 185, par.3, of the Lg.D. n.152/2006

The M.D. n.173/2016 explicitly regulates the excavation activities from *seabeds* with the purpose of reopening partially or fully obstructed river mouths.

Nothing is said with regard to analogous activities concerning the bottoms of bodies of *brackish waters* (mouths of rivers and lagoons, intended as types of transitional waters), which should therefore be regulated, in accordance to article 2 of Directive 2008/98/EC, by article 185, par.3, of Lg.D. n.152/2006 (introduced by article 13 of Lg.D. n.205/2010).

According to the aforementioned article 185, par.3, sediments relocated inside surface waters or within the area of hydraulic appurtenances «for the purpose of managing waters and waterways or of preventing floods or mitigating the effects of floods and droughts or land reclamation» are excluded from the application field of waste regulations, as long as it has been proven that they are «non-hazardous» according to the norms concerning the classification of waste and, in any case, «without prejudice to obligations under other relevant Community legislation»,

Some remarks and a few perplexities on the aforementioned point.

The norm introduces a teleological element which clearly restricts its scope of application, since it is only applied for the following purposes:

- a) management of waters and waterways;
- b) prevention of floods;
- c) mitigation of the effects of floods and droughts;
- d) land reclamation.

¹⁰ Should dredged materials be used in areas with naturally saline groundwater, sulphate and chloride concentration levels in the eluate could be allowed to exceed the parameters set by M.D. of 1998.

As for what concerns the destination of the sediments, it is not clear whether with «surface waters» the lawmaker intended to refer generically to the same «water body» or to the same «significant water body». In any case, the zoning scope that is determined by the norm has an imperative nature for land-based activities as well (e.g. land reclamation), which are necessarily contained inside the hydraulic appurtenances, that is, according to article 115 of Lg. D. n.152/2006, the «zone which is immediately adjacent to water bodies» («rivers, lakes, ponds, lagoons») which is «at least 10 meters [in width] from the bank» and subject to specific regional regulations¹¹.

Again: the movement of sediments is subjected to the assessment of their non-hazardousness according to the appropriate norms regarding waste characterization; should the waste result hazardous, it should be managed as special, obviously hazardous waste.

Finally, once the non-hazardousness of the sediments has been ascertained, their release downstream will be subjected – according to what the article 185, par.3, explicitly states – to the respect of any «*obligations under other relevant Community legislation*». However, article 185, par.3, does not specify what the specific Community legislation is. Nevertheless, it can be reasonably assumed that it refers to regulations intended to protect the environment, with special attention to aquatic ecosystems.

5. The management of dredged materials as *end of waste* according to art.184-*quater* of Lg. D. n.152/2006

Article 184-*quater* of Lg.D. 152/2006, introduced by D.L. n.91/2014, converted to Law n.116/2014, building on the general provisions of art.184-*ter*, regulates the end of the classification as waste of the dredged materials that have been subjected to a recovery (so-called *end of waste*).

The norm applies to any dredged materials that have been classified as waste, regardless of their origin, therefore including those within our purview, coming from the dredging of the bottoms of marine and brackish bodies of water. However, in my opinion, it does not apply to the recovery of materials dredged within remediation Sites of National Interest, which fall into the field of application of special regulation of article 5-*bis* of Law n.84/1994 and M.D. n.172/2016.

Art. 184-*quater* dictates that the dredged material cease to be waste if, once the recovery operation (which may also consist of selection and sorting operations) is concluded, certain requirements are met and they are used according to certain conditions.

In particular, in addition to the fact that the producer and the holder of the materials will have to report the type and the amount of the materials that have been used, any recovery operations that have been performed, the destination site and the mode of use for the recovered materials, they may be used provided that:

¹¹ Law n.164/2014, which converted D.L. n.133/2014, introduced in article 185, par.3, the referral to hydraulic appurtenances, that is not included in article 2 of Directive 2008/98/EC. With respect to the former text of article 185, par.3, Peres et al correctly pointed out that, as for the reuse of sediments for the purpose of «land reclamation», this could imply uncertainty on the extent of the same context, which should have anyway included «at least the portion of shoreline near the body of water». Cf. Peres F., Kiniger A., Lops C. (2013), *Dredged sediments management in Italy: legal aspects*, at www.buttiandpartners.com.

- a) in the case of *direct usage* (e.g. for landscape remodelling) the destination site must be known with certainty and the materials must not exceed the aforementioned Threshold Concentration of Contamination (CSC), referred to the site of destination in terms of urban planning (refer to what was said earlier regarding the CSC for the usage of the recovered materials on agricultural sites); the usage must not entail risks for the environmental matrix, with special regard for groundwater and surface waters (with exceptions for the limits of chlorides and sulphates should the dredged materials be placed in areas adjacent to the shoreline and should they be compatible with the levels of salinity of the local soil and aquifer);
- b) in the case of *usage in a productive process*, the materials must comply with the technical requirements for the specific purposes and with the regulations and standards applicable to the products and the raw materials; in particular, the usage of the materials must not entail greater or altogether qualitatively different levels of pollution from those deriving from the usage of the products and raw materials for which the production plant has been licenced.

A final remark on the point, although constrained by brevity. According to what article 184-*ter* dictates that, for the purpose of the authorisation of the recovery operation, any activity of waste recovery – including those involving dredged materials – should satisfy the criteria – adopted for each category of waste by the European Community or by Decree of the MATTM – concerning the admissible waste, the allowed treatment processes and techniques and the criteria regulating the quality of the resulting material, including the limit values for pollutants.

Considering the lasting absence of *ad hoc* regulations coming from the Ministry or from the European Community, the authorisation procedures for the recovery of dredged materials have risked being ‘frozen’ as a consequence of the well-known sentence of the Council of State, *sez.IV, 28 febbraio 2018 n.1229*, which subjected the release of regional authorisations to the entrance in force of the aforementioned ministerial decrees; the matter was addressed by the D.L. n.32/2019 (conv. into Law n.55/2019) in a blatantly inadequate fashion and eventually solved with Law n.128/2019 (article14-*bis*), which allowed Regions to grant the authorisations themselves, by fixing the criteria for the recovery operations in the very authorisations¹².

6. The applicability of the norms regarding excavation soil and rocks to dredged materials as by-products (d.P.R. n.120/2017)

The d.P.R. n.120/2017 is the regulation (of delegification) which disciplines the management of soil and rocks resulting as by-products of excavations, that is (art.4):

- a) for the realization of backfills and embankments, for the improvement of roads and foundations, for land remodelling, environmental recovery or other forms of environmental restoration or improvement;
- b) as a replacement for quarry materials in productive processes.

¹² Refer to Muratori A. (2020), *L'irrituale riscrittura dell'art. 184-ter del TUA e le linee guida SNPA riaprono all'EoW accertata dalle Regioni*, Ambiente & Sviluppo, (3), 189 -197.

Some clarifications are required regarding the applicability of the discipline to the material resulting from the excavation of the floor of the sea and of bodies of transitional water.

The d.P.R. n.120/2017 introduced a definition of «excavation soil and rocks» which does not fully overlap the one offered by its predecessor norm, the M.D. n.161/2012, which had been expressly abrogated (article 31).

In fact, the 2012 decree included in the definition of «excavation materials» (article 1, par.1, lett.b) also «lithoid materials in general and anyway all the other possible granulometric fractions coming from excavations made in beds of both surface water bodies and the drainage hydraulic network, in flood plains, beaches, lake-bottoms and sea-bed»¹³.

In the new definition of «excavation soil and rocks» assumed by the d.P.R. n.120/2017 the aforementioned category is no longer featured. Hence the doubt regarding the applicability of the new discipline to marine and brackish sediments.

The considerations featured in the Nota 20/2/2018 prot.2697¹⁴ by the MATTM – which were recently embraced in the textbook *Linee guida sull'applicazione della disciplina per l'utilizzo delle terre e rocce da scavo* (delib. n.59/2019 approved by the SNPA on the day 9/5/2019¹⁵) – come to the rescue by affirming the applicability.

Both the Nota by the MATTM and the *Linee guida* (cf. in part. § 2.2) state that the fact that the aforementioned materials are not explicitly mentioned in the definition of excavation soil and rocks does not actually prevent them from being included in the scope of application the d.P.R. 120/2017. The deciding factor is that article 3 in the decree, titled *Esclusioni dal campo di applicazione (Exclusions from the field of application)*, would explicitly refer, for what concerns us, to the sole hypotheses regulated by the art.109 of the d.lgs.152/2006 – that is, to the dumping at sea or in contiguous environments of material resulting from the excavation marine or brackish beds; therefore, for all hypotheses that are not explicitly excluded from the aforesaid article 3 and are not otherwise regulated (such as the extraction of lithoid materials regulated by paid mining concessions, as both the Nota by the MATTM and the *Linee Guida* remark) the application of the (general) norm described in the d.P.R. n.120/2017 should be unimpeded.

The remarks in question are certainly acceptable, in that they allow to fill interpretatively what would otherwise strike as a veritable legislative gap – with it being a circumstance not regulated in any other way – and, moreover, one which appears to stem from nothing more than an 'oversight' of the 2017 lawmaker.

As previously mentioned, the second issue pertains to the possibility of applying the regulations on excavation soil and rocks as by-products to the cases in which the removal of the material is justified by needs related to *hydraulic safety*. In this case, given the purpose of the activity, it would likely be impossible to prove that the action is in accordance with what is stated by art.4, 2° comma, lett.a, (which builds on art.184-*bis*, comma 1, lett.a), by virtue of which, to be classified as a by-product, a material must derive from a production process of which it constitutes an essential part but (here is the key issue) whose primary purpose is not the production of the material itself.

¹³ On the applicability of M.D. n.161/2012 to sediments, wherever dredged. cf. Cf. F. Peres, A. Kiniger, C. Lops, *Dredged sediments management in Italy*, cit.

¹⁴ http://www.arpa.marche.it/images/pdf/rifiuti/terre%20rocce%20da%20scavo/2018-02-20_2697_MATTM-alvei.pdf

¹⁵ <https://www.snambiente.it/wp-content/uploads/2019/05/Delibera-54-LLGG-Terre-Rocce-da-scavo.pdf>

The answer must be affirmative in this case as well, but only for excavation materials coming from transitional bodies of water and not for those coming from the seabed.

According to article 39, par. 13, of Lg.D. n.205/2010, in fact, article 184-*bis* must also be applied to «the material removed, solely for hydraulic security reasons, from the bed of rivers, lakes and creeks» This is an *ope legis* extension of the application field of art.184-*bis* regarding the situations in which the excavation is required by reasons of hydraulic safety, regardless of any evidence of the condition described in art.184-*bis*, comma 1, lett.a, by being satisfied; conversely, the aforementioned condition will have to be met should the material be removed for reasons other than hydraulic safety.

With the regulations on the treatment of excavation soil and rocks being applicable in the case of sediments removed from marine or brackish environments (again for reasons of hydraulic safety in the latter case), it will therefore be necessary to ascertain that the excavated material meets the requirements of environmental quality described in article 4 and Annex 4 to d.P.R. n.120/2017.

The conditions to be met are the respect of the forecited Threshold Concentrations of Contaminants (CSC) referred to the appropriate intended use according to urban planning (again, refer to what previously said regarding the CSC for agricultural areas), all while considering the extant values for the natural background (article 11) and the limits of acceptability for excavation material (article 4, par.3).

It may be beneficial to remember that the Annex 4 to d.P.R. n.120/2017 states that the set of analytical parameters to be measured – save for the minimum analytical set – must be defined «according to the possible substances which may be linked to human activities that are or have been carried out on the site or in its vicinities, to the characteristic parameters of possible predating contaminations, to possible anomalies in the natural background and to the potential spread pollution, as well as to any possible contribution coming from the excavation itself ».

7. References

- [1] Beltrame S. (2007) - *Come «disfarsi» lecitamente dei fanghi (e materiali vari) provenienti dai dragaggi: un problema che intuitivamente riguarda tutta la penisola*, Riv. giur. amb., 332 - 349.
- [2] Fimiani P. (2020) - *Classificazione dei rifiuti: dopo la Corte di Giustizia la Cassazione apre una nuova fase*, ReteAmbiente
- [3] Garzia G. (2004) - *Il regime giuridico delle attività e dei materiali di dragaggio dei fondali in aree portuali*, Riv. giur. amb., 849 - 859.
- [4] Lolli I. (2010) - *Il regime autorizzatorio delle attività di movimentazione di materiali in ambiente marino e costiero nel riparto di competenze fra Stato e Regioni*, Atti del 3° Simposio "Il monitoraggio costiero mediterraneo: problematiche e tecniche di misura", CNR Ibimet, Firenze, 701 - 714.
- [5] Losengo R. (2020) - *Rifiuti con codici "a specchio": dopo il vademecum della Cassazione sulla pronuncia pregiudiziale della Corte di Giustizia continua la "guerra d'opinione" sulla classificazione (e si rischia di dimenticare il diritto penale)*, RGAonline, (11), 1 - 8.

- [6] Muratori A. (2020) - *L'irrituale riscrittura dell'art. 184-ter del TUA e le linee guida SNPA riaprono all'EoW accertata dalle Regioni*, *Ambiente & Sviluppo*, (3), 189 – 197.
- [7] Peres F., Kiniger A., Lops C. (2013) - *Dredged sediments management in Italy: legal aspects*, at www.buttianpartners.com, 1 – 8.
- [8] Piccolo F. D., Squillante D. (2007) - *Le problematiche del dragaggio dei fondali portuali tra esigenze di sviluppo e vincoli giuridici di compatibilità ambientale*, www.innovazioneDiritto.unina.it

DOMITIAN COAST. REHABILITATION' OUTLOOKS OF THE NORTHERN COAST OF CAMPANIA

Giuseppe Mazzeo

CNR – Istituto di Studi sul Mediterraneo, Via Guglielmo Sanfelice, 8, 80134, Naples (Italy),
phone +39 081 7682315, e-mail: giuseppe.mazzeo@ismed.cnr.it

Abstract – Object of the paper is the Domitian Coast, an area belonging to the North-West of Campania Region, characterized by a series of contrasting factors. The fertility of the soil and the considerable length of an easily accessible and available coastline are threatened by an indiscriminate exploitation of the ground for anthropogenic uses.

The uncontrolled expansion of urbanized areas and the reckless use of soil have transformed a potentially rich land into an example of a kind of management that is completely indifferent to the territorial risks. This state of affairs puts the brakes on any kind of developmental action.

Policies tending to the redevelopment of urban centres and to the regeneration of natural and agricultural sites are focusing on this area. In fact, there is no lack of territorial planning and programming tools, despite the poor results. Therefore, it is not possible at the moment to forecast or, in any case, to hypothesise a future improvement of the situation.

The first part of the paper analyses the Domitian territory and the issues characterizing this particular area on the basis of three categories of elements. Starting from the problems encountered, the second part indicates the possible intervention policies set up to redevelop this territory.

Introduction

The Domitian coastal strip in the Campania Region extends for about 52 kilometres from the estuary of the Garigliano, at the border of the Lazio Region, to the Municipality of Bacoli, in the Phlegrean Fields.

The territory is part of the Province of Caserta and of the Metropolitan City of Naples and it is divided, from North to South, between the Municipalities of Sessa Aurunca, Cellole, Mondragone, Castel Volturno, Giugliano in Campania, Pozzuoli, and Bacoli, with a resident population of over 300 000 inhabitants.

The area has a flat surface, with extended sandy shores that, until a few decades ago, had a rich Mediterranean-type greenery behind them. Some segments of this greenery are still in existence and, together with other environmental uniqueness, are preserved under different types of environmental protection.

Large part of the coastal strip shows a severe urbanization process, often caused by illegal settlements; this disordered development caused considerable damages to pre-existing habitats and the same protected areas are subject to strong anthropic pressure being surrounded by urbanized areas pressing along their borders.

In the 1960s this urbanization process was favoured by the tourist discovery of the Domitian Coast and by the localisation of a series of centres characterized by a strong

landscape impact (an example for all, Villaggio Coppola Pinetamare), and by a very low attention to the territorial specificities and to their preservation. Starting the 1980s, the dream of the Domitian tourism reached a crisis, due to the impossibility of defending an image of the territory that was no longer winning, due to its association with the deterioration of the land and the pollution of the sea, to say nothing of the criminal phenomena.

The Domitian coastal strip requires a comprehensive and systematic rehabilitation process; it would concern the entire coastal strip and would modulate the actions in a differentiated way between the areas in relation to their level of deterioration. This type of process of territorial and environmental rehabilitation, however, seems to be remarkably difficult to carry out due to some negative factors, such as the strong anthropic pressure, the uncontrolled use of the territorial resources, the apathy towards the continuous and uncontrolled harmful spills, and the connivance of large sectors of civil society and local administrations with the organized crime, aiming to keep their control of the territory.

A system of territorial plans is present on the area. Starting from the Regional Territorial Plan [1], up to the territorial plans of the Province of Caserta [2, 3] and of the Metropolitan City of Naples [4], the characteristics of the present problems have been analysed in depth. These plans also contain many indications for changing the evolutionary trends of the area.

To deal with the lack of decisiveness of these planning tools, perhaps, the Campania Region is setting an overall masterplan for the area (Masterplan Litorale Domitio-Flegreo [5]) based on a set of specific interventions placed in a systematic plan aimed at establishing a common thread or an assessable impact on the whole area.

The attention of the Campania Region, dating back to the beginning of the Nineties with the mentioned Regional Territorial Plan, and the need to start a process of physical and functional reorganization of the area, make it necessary to develop a stronger and innovative system of intervention and monitoring of results based on new uses of the territorial resources and on the creation of a renewed territorial quality.

Materials and methods

The length of the Domitian Coast is about 52 km. It is a totally sandy coast. Behind it there is a flat territory, the north side of the Campanian lowland, called *Campania Felix* by Plinius the Old.

The territory belongs to the Campania Region, to the Provinces of Caserta and Naples and to seven Municipalities. Between the 2011 Census and the last survey in 2019, the resident population of the seven Municipalities grew from 295 650 to 314 728 inhabitants.

Anthropogenic pressure on the coast is very strong due to a series of factors that have accumulated over time and have almost never found a solution. Among these causes we can mention the fast and indiscriminate expansion of the urbanized land, the abandonment or improper use of agricultural land - sometimes used for the illicit trafficking of waste -, the lack of treatment of urban, agricultural and industrial discharges, the proximity to the Neapolitan metropolitan system with the strong pressures caused by a population of over three million [6].

The analysis of the data on the use of land highlights an interesting element. Going from North to South, therefore getting closer to the metropolitan area of Naples, land consumption increases significantly. Table 2 shows that the percentage of consumed soil varies from the 7.50 % of Sessa Aurunca to the 38.77 % of Bacoli [7].

Table 1 - Population change of the Municipalities (2011-2019).

Municipalities	Population 1-1-2019	Population 2011 Census
Sessa Aurunca	21 154	22 216
Cellole	7 994	7 684
Mondragone	29 071	27 070
Castel Volturno	25 923	22 882
Giugliano in Campania	123 490	108 793
Pozzuoli	123 851	80 357
Bacoli	26 245	26 648
Total	314 728	295 650



Figure 1 - Position of the Domitian coast in the territory of the Campania Region.

Table 2 - Soil consumption, 2018.

Municipalities	Municipal territory (ha)	Soil consumed (ha)	Soil consumed (%)
Sessa Aurunca	16 218	1 211.57	7.50
Cellole	3 679	466.12	12.71
Mondragone	5 572	672.90	12.12
Castel Volturno	7 395	1 304.40	17.70
Giugliano in Campania	9 462	2 397.21	25.43
Pozzuoli	4 344	1 446.82	33.44
Bacoli	1 347	520.16	38.77

These data show that the critical areas of the Domitian Coast become increasingly dense going from North to South, demonstrating the high direct relation between human concentration of activities and territorial problems.



Figure 2 – Methodological analysis flow chart.



Figure 3 - Critical areas along the Domitian Coast.

To analyse the state of the coastal strip, the paper followed a qualitative method which can be systematized in the following phases (see Figure 2): 1) identification of the critical areas on the coastal strip, 15 in number; 2) association of the critical areas to one of three different categories (urban centres; rivers, wetlands and protected or natural areas; archaeological sites); 3) identification of the critical factors of the categories; 4) identification of actions and tools for solving critical issues (development and rehabilitation).

The 15 areas (see Figure 3) belong to a territory that is very limited in extension but very complex because of its morphological conditions, environmental situations and impacts of human activities. Areas must then be classified in three categories. The first are the natural areas, including protected sites, areas covered by Mediterranean maquis, and wetlands characterized by the presence of rivers and lakes. A second category is represented by the settlement systems which extend both along the coast and inland and are characterized, for the most part, by the lack of an organic urban development plan. The third category is that of archaeological sites, representing one of the main points of potential touristic interest of the area. These three categories of critical areas present distinct positive and negative characteristics.

The natural areas that are still present are what remains of a much wider environmental system that has endured an intense process of fragmentation over the past 50 years. Both natural areas and water systems suffer from this fragmentation, which is caused by the anthropic pressure present along the borders of what can be considered real islands of nature [8]. None of them, in fact, can count on a territorial belt, which would act as a buffer zone able to reduce the anthropogenic pressure. Furthermore, fragmentation has a negative impact on the establishment of ecological corridors.

Among the critical issues related to this category are the widespread practice of illegal discharging into water bodies and the high anthropic pressure, especially in the summer, on a very wide and very fragile coastal dune belt [9].



Figure 3 - State reserve of Foce Volturno. Oasi dei Variconi, Castel Volturno. Source: Google Maps. Geographical coordinates: 41.0210081,13 9343687,30. (Retrieved: 8/6/2020).

With regard to settlements, the lack of urban plans has already been mentioned. In addition, we should highlight the lack of control over individual transformations which has fostered a speedy expansion of urbanised areas and a structure based on low-density and high-soil-covered spaces [10]. It can be said that urban development has been directly outsourced to the entrepreneurial or criminal entities that have carried it out, often with the complicity of administrations and citizens. The proximity to the metropolitan area of Naples and the settlement pressure resulting from the formation of the axis from Naples to Caserta [6] has emphasized and systematised the phenomenon.

It is also clear that this type of urban development has affected not only the quality of the building system (see below) but also that of the system of public services and equipment, the deficit of which is still very relevant. Finally, we cannot fail to point out that this type of development has also accelerated the ageing process of buildings; most of these were built with poor quality products and unskilled labour, and have undergone a rapid process of degradation that has fostered the wider social and economic degradation present in the area.

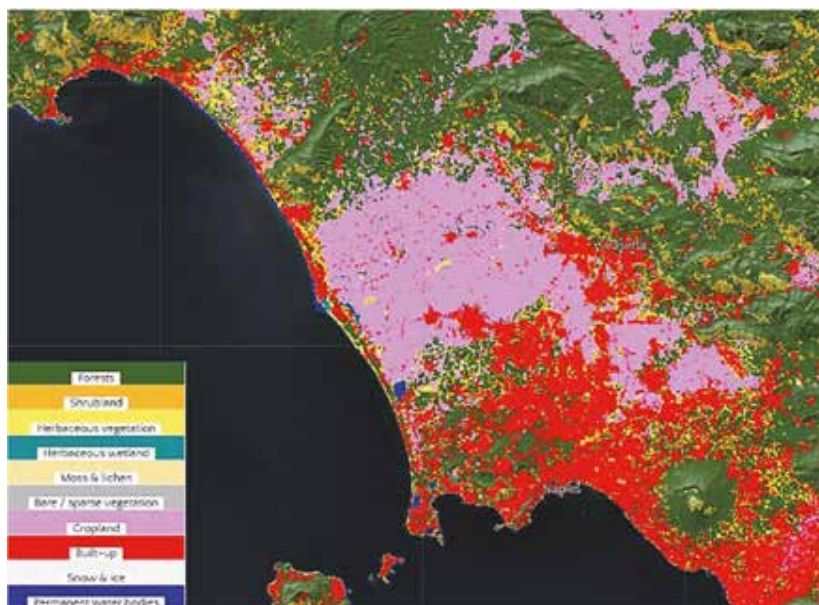

Figure 4 - Global Land Cover. Single Class Forest. 2015. Source: <https://lcviewer.vito.be/> (Retrieved: 8/6/2020).

The third category represents a potential development factor of the area, as well as one of the main weaknesses of the policies pursued so far. The archaeological area of Cuma, in particular, falls within a larger area of archaeological sites - that of the Phlegraean Fields - which, if it were organized as a cohesive system, would represent an amazing territorial attraction. The lack of this coordinated system has decreased their attractiveness, since each single site is isolated from the territory and from the mobility systems [11].



Figure 5 - *Ecoparco del Mediterraneo*, Castel Volturno. One of the access road [A] and a glossy image of the tourist facility [B]. Source: [A] Google Maps. Geographical coordinates: 40.998873, 13.9774333. (Retrieved: 8/6/2020). [B] <https://eventinapoli.com/cosa-fare/fuoriporta/100-l-ecoparco-del-mediterraneo-un-oasi-di-benessere-e-turismo-sostenibile>. (Retrieved: 8/6/2020).

The importance of this category also lies in the fact that the Domitian territory is an intermediate sector between two areas, to the North and to the South, both strongly characterized by Greek-Roman archaeological remains, evidencing a long-standing settlement history.

The enhancement of archaeological areas is directly tied to the tourist vocation of the Domitian belt. In the 1960s, this vocation led to the construction of tourist settlements which became an example of the territorial transformations during the Italian economic boom. The two most important touristic settlements, Baia Domitia and Villaggio Coppola Pinetamare, were built during this time.

These settlements were born when the area had not yet been subject to subsequent upheavals and still showed intact potential. The dream was to develop the area as an high quality national and international tourist attraction, but the constant attack on the coastal strip, due to the wild urbanization and the construction of other settlements, which were mostly illegal, led to the area becoming almost exclusively attractive to local daily tourism.

Some recent high-quality initiatives tend to detach themselves from this situation, but they inevitably suffer from the localization within such a difficult territorial matrix. Some examples are the Volturno Golf Club, a sports complex with golf courses and accommodation facilities, or the *Ecoparco del Mediterraneo* (Mediterranean Ecopark), described as a tourist structure with high environmental sustainability built on some of the artificial lakes present in the lowland areas, which were formed over time due to the excavation of limestone material intended to support the Domitian building boom.

Some points of reflection

On the Tyrrhenian coast between Garigliano River and Monte di Procida, new settlements have seen rapid development in the last fifty years, previously impeded by the need to complete land reclamation and to build modern communications. With the construction of the Domitian State Road, which was further widened in recent years, the coast has been gradually urbanized, mostly featuring tourist facilities and services. Castel Volturno and Mondragone have experienced a turbulent and unorganized development along the coast line.

The quality of these settlements is very limited. Perhaps, the centre which best fits in the landscape is Baia Domizia, a tourist settlement that has been constructed according to advanced criteria of landscaping and architecture (as boasted by designers and investors), in order to attract Italian and foreign tourists seeking medium to high-class level holiday facilities [10].

Outside the residential centres, there also many holiday homes, isolated hotels and camping grounds along the coast. Today about 30 % of bathers from Campania choose this stretch of coast for their summer stay. Foreign tourism is also steadily rising.

It is urgent, however, that measures should be taken towards the planning of further development, to prevent the disorderly expansion of urban centres from spoiling the attractiveness of this stretch of coastline. At the same time, it is essential to put in place a radical action for the rehabilitation of the existing settlements, with the aim of increasing their structural and architectonic quality and strengthening the social and economic structure of the population.

It is also necessary to deal with some of the environmental problems. An aspect that is positioned halfway between environmental and social problems is the unsolved garbage issue. A series of studies [12] investigated the indiscriminate abandonment of all kinds of waste in an area of Campania which is infamously called "Terra dei Fuochi". The delimitation of this territory is uncertain and indefinite, but it does include the Domitian Coast. The scientific studies show that surveys, including remote sensing and photointerpretation, together with ground analyses, are effective and efficient tools for monitoring the area. The use of unloading sites for the storage of highly dangerous waste, illegally used as landfills by subjects allegedly attributable to the criminal organizations that have invested in the waste business, have a serious impact on the image of the territory, as well as more serious repercussions on the health of the inhabitants [13].

This issue is directly related to the situation with illegal discharges in the sea which, in past years, have often made the Domitian Coast not suitable for swimming.

Another important environmental problem is the coastal erosion. The coastal system is a complex natural structure, based on delicate a physical, chemical and biological equilibrium, strongly affected by anthropic interventions. The Domitian Coast is characterized by a low and sandy coast and it is mainly influenced by the dynamics of the rivers Garigliano and Volturno. At present, this system is severely compromised, due to the intense exploitation of the territory that has profoundly changed the morphological structure of the natural landscape.

The main aspect underlining the instability of the coastal system is the retreat of the shoreline following the increase of erosive phenomena due to the anthropic pressure exerted in the last fifty years. The coast was, in fact, subject to a strong destabilization with the disruption of the dune system caused by the construction of seaside resorts, residential villages and marinas, as well as due to the anthropization of the coast for other purposes. Another significant cause for this deterioration is the continuous removal of sand and gravel from riverbeds and the development of activities in the upper part of river basins, all of which impoverish the natural flow of solid material from rivers into the sea [3].

The characteristics of the Domitian Coast define a case of territory to be fully redeveloped. From the physical aspects to the environmental components, from the economic situation to the social elements of the area, the Domitian territory represents a paradigmatic case of study, where a singular unregulated development process has been experienced, resulting in the commitment of some of the most nationwide discussed settlements operations of the last decades.

The concentration of negative factors, compared to the amount of unfulfilled potential, is perhaps the most interesting starting point from which to deepen credible hypotheses of intervention. Without a careful analysis of past circumstances, it is extremely hard to define credible territorial redevelopment policies. Moreover, without careful reconnaissance of existing and potential resources, we could risk finding ourselves basing intervention policies, even onerous ones, on nothing.

References

- [1] Regione Campania (2008) - *Piano Territoriale Regionale. Relazione. Legge regionale n. 13/2008*, Napoli.
- [2] Provincia di Caserta (2012a) - *Piano Territoriale di Coordinamento. Al Relazione. Delibera di approvazione DCP n. 26, 26/04/2012*, Caserta.
- [3] Provincia di Caserta (2012b) - *Piano Territoriale di Coordinamento. El Schede programmatiche: interventi infrastrutturali e progetti territoriali prioritari. Delibera di approvazione: DCP n. 26, 26/04/2012*, Caserta.
- [4] Città Metropolitana di Napoli (2016) - *Piano Territoriale di Coordinamento. N.01.0 Relazione. Delibera di adozione DSM n. 25, 29/1/2016 e n. 75, 29/4/2016*, Napoli.
- [5] Regione Campania (2019) - *Masterplan "Programma integrato di valorizzazione litorale Domitio- Flegreo"*. DGR n. 403, 03/09/2019.
<https://www.territorio.regione.campania.it/urbanistica-blog/litorale-domitio-flegreo>. Retrieved 5/6/2020.
- [6] Papa R. Mazzeo G. (2014) - *Characteristics of sprawl in the Naples Metropolitan Area. Indications for Controlling and Monitoring Urban Transformations*, Computational Science and Its Applications - ICCSA 2014. 14th International Conference, Guimarães, Portugal, June 30 - July 3, 2014, Proceedings, Part II. Murgante, B., Misra, S., Rocha, A.M.A.C., Torre, C., Rocha, J.G., Falcão, M.I., Taniar, D., Apduhan, B.O., Gervasi, O. (Eds.). Lecture Notes in Computer Science, Vol. 8580, pp. 520–531. Springer International Publishing Switzerland. DOI: 10.1007/978-3-319-09129-7_38.
- [7] Munafò M. (ed.) (2019) - *Consumo di suolo, dinamiche territoriali e servizi ecosistemici*, Edizione 2019. Report SNPA n. 8/2019. ISPRA, Roma.
<http://www.isprambiente.gov.it/it/temi/suolo-e-territorio/il-consumo-di-suolo/i-dati-sul-consumo-di-suolo>. http://groupware.sinanet.isprambiente.it/uso-copertura-e-consumo-di-suolo/library/consumo-di-suolo/indicatori/consumo_suolo_2019_com_prov_reg_it_1_1 (Access, 28/3/2020).
- [8] Iovino G. (2018) - *Trasformazioni del paesaggio costiero e aree protette in una regione del Mediterraneo*. Bollettino della Associazione Italiana di Cartografia. 164, pp. 83–99. DOI: 10.13137/2282-572X/27108.
- [9] Zerlenga O., Girafici A. (2005) - *La costa campana*. In R. De Rubertis (ed.), *La riva perduta. Piano di monitoraggio e di riqualificazione delle fasce costiere italiane*, Officina Edizioni, Roma, pp. 231–236.
- [10] Manzi E. (1970) - *Lo sviluppo recente dell'insediamento sul litorale della Pianura Campana*. Rivista geografica italiana. 77 (1), pp. 47–75.

- [11] Losco S., De Biase C. (2015) - *Pianificazione del territorio, politiche e programmi per lo sviluppo turistico nella provincia di Caserta*. *Agribusiness Paesaggio & Ambiente*. XVIII (1), pp. 62–73.
- [12] Bettini V., Morigi M. (2007) - *Telerilevamento e fotointerpretazione per la scoperta di discariche illegali*, *GEOMedia*, 5, pp. 16–20.
- [13] Mitis F., Bianchi F., Comba P., Fazzo L., Martuzzi M., Minichilli F. (2007) - *Valutazione degli impatti sanitari legati al ciclo dei rifiuti in Campania*, *Salute pubblica*, I (III), pp. 7–9.

STRATEGIC PLANNING DOCUMENT OF PORT AUTHORITY SYSTEM, A NEW CITY-PORTS AGREEMENT: THE CASE OF NORTHERN TYRRHENIAN SEA ADSP

Isabella Palano¹, Andrea Del Corona², Laura Montioni³,
Francesca Pichi⁴, Matteo Scamporrino⁵

¹Università degli Studi di Firenze, Dipartimento di Architettura, Via della Mattonaia, 14 -
50121 Firenze, phone: 348 8306371, e-mail: isabella.palano@stud.unifi.it

²Autorità di Sistema Portuale del Mar Tirreno Settentrionale, Scali Rosciano, 6/7 - 57123 Livorno,
phone: 0586 249411, e-mail: a.delcorona@portaltotirreno.it

³Università degli Studi di Firenze, Dipartimento di Architettura, Via della Mattonaia, 14 -
50121 Firenze, phone: 331 4344610, e-mail: laura.montioni@stud.unifi.it

⁴Autorità di Sistema Portuale del Mar Tirreno Settentrionale, Scali Rosciano, 6/7 - 57123 Livorno,
phone: 0586 249411, e-mail: f.pichi@portaltotirreno.it

⁵ Università degli Studi di Firenze, Dipartimento di Architettura, Via della Mattonaia, 14 -
50121 Firenze, phone: 339 2218196, e-mail: matteo.scamporrino@unifi.it

Abstract – Legislative Decrees 169/16 and 232/17 have modified Law 84/94, bringing port planning closer to that of European and global port areas, with which the new AdSPs are called to interact and compete. In particular, the changes concern art. 5 of the Law, which introduces the Port System Regulatory Plan, composed of the PRPs of the individual ports of the system and the Strategic System Planning Document (DPSS). The distinction in two levels is similar to that already consolidated in territorial planning: a strategic and guiding level, the DPSS, and an operational level represented by the PRPs. Among the contents of the DPSS, for which institutional agreements between AdSP and territorial bodies are envisaged, there is the identification of the so-called "Areas of port-city interaction". Identifying these areas means redesigning urban and port areas and regaining space, making planning easier by eliminating institutional conflicts through new agreements. The objective of this research, the result and synthesis of the "City-port agreements" degree thesis, is to propose a methodology for identifying the areas of influence of the port on the city, measuring the "degree" of interaction through a system with indicators. The study formed the basis for the perimeter of the new port-city interaction areas within the DPSS of the AdSP of the North Tyrrhenian Sea.

Introduction

The reference law of Italian portuality, Law 84/94, has been radically re-discussed. The latest reform provides for the reorganization, rationalization and simplification of the port discipline according to a new “*system vision*”, which inserts the port infrastructures in a matrix on a territorial scale, linking them to other nearby maritime contexts according to economic, commercial, logistic and transport vocations.

To the newly-established Port Network Authorities is entrusted the control, the government and the planning of very vast territories, potential logistic ambits constituted

not only from the single harbour nodes, but also from the back ports, from the interports, from the airports and from the great road and railway networks, to organize in relation to the more and more complex commercial exchanges and to the infrastructural and industrial development needs of our Country and Europe [D'Amora et alii, 2019].

The strategic approach is necessarily flanked by the introduction of a new instrument of government of the port territory, the Port System Regulatory Plan, a complex plan, which organizes and develops a plurality of functions related not only to the transport of goods and passengers, but also to industry, shipbuilding, the support of production activities, the connection with the cities and territories, departing significantly from the old port program of maritime infrastructure works planned until a few years ago [Pavia, 2018].

The PRdSP is a composite tool that intercepts a considerable number of themes, even heterogeneous, structured on two levels: the Strategic System Planning Document (DPSS) and the Port Regulatory Plans at the scale of a single port node. The division into two stages and two instruments is an important step in port planning. The drafting of the DPSS becomes in fast the moment in which the possibility of preparing in a coordinated and shared way a medium and long term strategic reference framework for the development policies of vast areas, in which different administrations converge but whose aim is to prepare a system in which the port, the city, the territory and the connection networks constitute a perfectly integrated complex of choices and solutions [Pavia, 2018].

The strategic contents of the DPSS are distinguished between those related to the purely operational scope of the port and those related to the areas of interaction with the city. The aim of this distinction is to make it easier to govern the territory, eliminating administrative conflicts: a clear division of tasks seems to be emerging between the AdSPs, which are entrusted with the planning of the operational port area, and the Municipalities, which must plan the areas of port-city interaction. In reality, the DPSS requires a strong sharing of choices between the two administrations: AdSP and local authorities must necessarily agree on the planning of areas of interaction, the AdSP preparing a discipline of use, and the Municipality promoting projects and interventions consistent with the objectives of port system planning, hoping for redesign de urban areas.

The objective of this research is to propose a methodology to support the identification and perimeter of the areas of interaction between port and city. To this end, a system of indicators has been set up to measure the degree of interaction between the two systems, identifying urban areas where the port has less or more influence. The method has been applied and tested within the cases of interaction relating to the ports of the Northern Tyrrhenian Sea AdSP.

Legislative Decree 169/2016 assigns to AdSP MTS the task of governing the territory of the ports of Livorno, Piombino, Portoferrario, Rio Marina, Cavo and Capraia Island.

Areas of port-city interaction

The relationship between the city and the port still appears to be marked by strong doubts and conflicts. Conflicts between insitutional figures, decisions, use of space, co-presence of heterogeneous functions: the conflicts take place on a "*field*" that follows the linear development of the port and logistic areas, defining itself as a border strip between the urban fabric and the activities related to the port [Di Venosa, 2006].

In the dynamics of transformation of this “*field of conflict*”, widely analyzed by the literature on the subject, it is commonly observed a process of complex separation between two elements: on the one hand, the city tends more and more to reappropriate some portions of the port, especially those of historical and identity character; on the other hand the port is always in constant search of more functional and large spaces to chase the growing innovations of technology and logistics. These two dynamics contrast within the same hinge, causing urban, administrative and social chaos. Also called “*interstitial periphery*” or “*abandoned threshold*”, the hinge often highlights conditions of marginality, the result of its nature as a frontier place between different spatial systems and organizations [Di Venosa, 2006].

To increase the conflict and the connotation of these hinge spaces, together with the heterogeneous and fragmentary nature of the objects inside, the very strong and concentrated presence of different flows and mobility networks, referred to the multiple activities present in the areas. In this perspective, the space through the port city can be interpreted as a powerful, but imperfect, “*connection space*” within which flows, at distinct speeds and with highly differentiated needs, the material flows of carriage traffic to the port and urban crossing, but also the virtual networks of trade, financial transactions that enhance the port node and its planetary relations [Di Venosa, 2006].

The overlapping of these different flows increases the separation between the city and the port, but also the contrasts and critical issues: the conflict, which in many ways can be considered irreducible, can and must also be a central node of which to direct planning in order to mend the relationship between the two systems. The hinge area between the port and the city can therefore become the space for dialogue and cooperation.

The new rationalized port planning, closer and closer to the territorial one, shows particular concentration on the hinge space, the one that literally connects the sea ports, and allows them to function, with the cities and territories. The theme of the definition and perimeter of the areas destined to the operating port and of those of interaction between port and city is in fact one of the cardinal elements of the DPSS, in which a division of a tasks must be delineated: to the Port System Authority that of the management of the operating port, while to the Local Authorities that of the planning of the areas of port-city interface. Despite the separation, in reality the process remains and must remain strongly anchored to a principle of shared choice [Pavia, 2018].

As defined by law, the AdSP must identify and perimeter the port-city interface areas, but it needs an opinion from the municipalities affected by the System, which will then be entrusted with the planning. The identification of the port-city interactions areas is an important but the same time delicate step, as it must constitute a real pact of pact of urban quality and shared planning between the port and the city.

Measurement: methods and instruments

This experimental research work is contained in the degree master’s thesis in Architecture *City Port Agreements*, carried out in collaboration with the Northern Tyrrhenian Sea Port System Authority. The research aims to be a tool to support the DPSS to identify areas of influence and interaction between port and city.

The need to define an *ad hoc* methodology stems from the absence, in the new regulations on port planning, of specific guidelines on the new issues dealt with. The reform

imposes, in fact, within the Document, the perimeter of the areas of port-city interaction, in order to determine new boundaries of competence between port and territorial planning. But it doesn't define how. In addition, the Guidelines issued by the Ministry of Infrastructure and Transport (MIT) for the drafting of the DPSS do not refer to previous methodologies or experiments on the topic of port-city interaction, thus leaving freedom to the AdSPs in the discussion.

The tested method aims to provide an assessment of the degree of interaction through an indicator-based measurement: the choice and use of indicators as a tool to support development and planning policies is now widely recognized and the subject of initiative by the main international and European organizations, which have developed, over the years, pilot experiences and guidelines on characteristics and criteria for the construction of indicator systems.

The proposed methodology is based on a two-step comparative analysis.

- In the first phase a “state of affairs” measurement is made. This makes it possible to determine the most critical areas of interaction and, at the same time, those in which interaction is positive.
- In the second phase, instead, a “project scenario” will be evaluated, in which through the analysis of the general planning and implementation, territorial and port, the coherence of the instruments and projects is determined and therefore the possible need for dialogue between the parties for the best management of the area in question.

Evaluations are carried out on “hinge areas”, areas in which a parallel analysis of physical and functional relationships is carried out, from which emerge projects and emergency issues regarding the interaction between systems. In fact, through the study of territorial planning, including in particular the Territorial Planning Plan (PIT) of the Region of Tuscany and the municipal structural and strategic planning, we highlight those multi-scale elements considered a “statute” of the port-city. At the same time, an analysis of the functional relationship between urban and operational port areas makes it possible to determine the interweaving, or clear separation, between the two areas. The analysis will be based on the location of the urban functions related to port and port activity and the purely port functions in the urban fabric.

The overlapping of the functional and the physical-statutory relationship will allow to divide the study into homogeneous areas, on which to carry out the interaction evaluations. The hinge areas are in different number and size and, in the case of ports belonging to the Northern Tyrrhenian Sea System where the function or class is single (for example port of Rio Marina, where there is only the yacht-tourist function), the evaluation area will be one.

The indicators chosen for the evaluation are the result of comparison and intersection of sets of urban and port indicators, already used or studies by organizations of national and international relevance (OECD, ESPO, etc.) using urban and port indicators. In particular, the research was conducted not explicitly referring to the specific case, but trying to identify the most recurrent, relevant and above all measurable issues in any context.

The measurements, carried out as already specified in two stages, are carried out in GIS environment, through direct surveys and consultation of technical data sheets attached to plans and projects. The comparison between the current status and the forecast status will be made through matrices, graphs, analysis and cartographic elaborations.

The tested method can be summarised in the following points:

1. Analysis of the physical relations and definition of the statutory elements of the port-city
2. Analysis of functional relationships based on port vocations
3. Identification of hinge areas on which to perform interaction assessments
4. Indicators abacus preparation
5. Measuring in two phases:
 - Current status
 - Future planning scenario
6. Comparison of the two phases
7. Evaluations

Hinge areas: physical and functional relationships

The assessments are carried out on areas of the territory defined as “hinge areas”, recognised as homogeneous due to the co-presence of the following factors.

First of all, the presence of elements resulting from the analysis of physical interaction: territorial planning, in particular in the PIT and PS of the municipalities in which the ports of the AdSP MTS are inserted, it is highlighted the presence of elements that constitute a statute of the port-city, both of an historical-patrimonial nature and of an emergency and critical nature with regard to the protection of the landscape and the environment. Moreover, the presence of factors resulting from the functional relationship between the city and the port: the urban functions present in the port area and the port functions present in the city fabric form intersections between the two systems, creating a sort of extension of the urban perimeter within the port, and the port perimeter within the city. Such links between city, port and territory create cross-cutting harmony: these presuppose an assessment of compatibility. In fact, the localization of urban functions in the port environment, and vice versa, requires adaptation to the laws and rules of the territory in which it is located, where the criteria for the localization of functions, organization, security and management can be very different. Functional compatibility between port and city is an element underlying the measure of interaction, and thus the balance between the two systems.

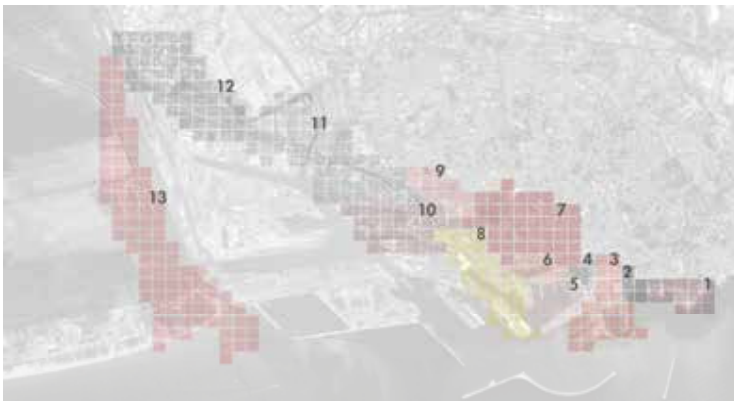

Figure 1 - The 13 hinge areas for the analysis of interactions in the port of Livorno.

Indicators

Monitoring and evaluation through indicators arise from the need to measure actions, interventions and transformations of complex systems. These systems, of an economic, ecological, social, urban planning type, are subject to continuous variations of the phenomena that take place within them; for these reasons it's necessary a constant, fast and effective monitoring of their transformation mechanisms. Due to the large number of elements and reports, monitoring requires operational methods that provide concise and understandable information. Complex systems also include port systems. The specificities that characterize them – activities, resources, interests, problems – are closely related and, in some cases, are “even” of the cities where the ports are located. For these reasons, it's considered necessary to define a methodology for monitoring such links and interactions, using indicators built *ad hoc*. In particular, the indicators will be useful to monitor city-port interaction realities even in very different situations.

The system of indicators is the result of research, comparison and intersection of sets of urban and port indicators already used or studied by organizations of national and international relevance.

The crossing and evaluation of the validity and applicability of the indicators to the case study present in the different sets, allowed to define the indicators and the evaluation themes.

Table 1 - Indicators and evaluation topics.

Indicators	Evaluation topics
Land use and functions	The incidence of functions in the hinge areas
Infrastructure connections and mobility	The accessibility and permeability of the areas with respect to the different flows
Administrative competences and soil law	The relationship between administrative and planning competences (PS-PRP)
Environmental and landscape impacts	The impact of the port area on the city and vice versa. Factors that most influence environmental, landscape and visual issues
Social usability and liveability	Compliance with the quality standards of urban settlements. The usability of hinge areas by citizens
Tourist and cultural attractiveness	The possibility of offering tourist and cultural services, also considering the relationship between the port fabric and urban morphology

The structural scheme of the indicators provides for a series of “operations” to be carried out in order to obtain the processed data that make up the indicator: these are the definitions, heterogeneous for each indicator in terms of units of measurement and quantity. Below is an example of the indicator “Environmental and landscape impacts”.

- Ratio between the protected areas area and the total area of the interface area
- Ratio between the green areas and the total area of the interface area
- Ratio between the surface area of high frequentation area and the total surface area of the interface area
- Ratio between the surface area of warehousing/goods handling areas and the total surface area of the interface area

- Ratio between the surface area of degraded or abandoned areas that alter the waterfront and the total surface area of the interface area
- Ratio between the surface area of reclaimed land covered by the last PRP and the total surface area of the interface area
- Average number of vehicles passing through the area at rush hour (7.45-9.00)

Reading the data and comparing the results

The final reading requires a homogenization of the data from the measurements. It is necessary in order to elaborate and represent the interaction assessments to identify a standard of interpretation. Thresholds are therefore defined for the values of the indicators,

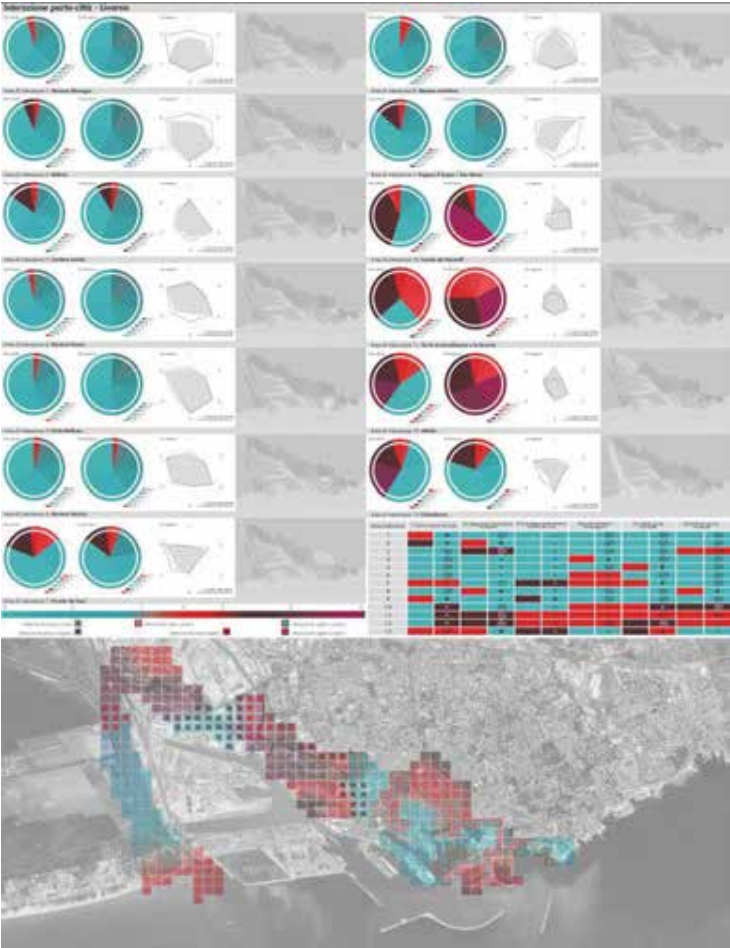

Figure 2 - Synthesis table related to the port-city interaction of the port of Livorno.

which allow the classification in positive, average and negative according to the type of indicators chosen. The thresholds are conventionally defined as follows:

- Negative assessment: from -3 to -1
- Average or irrelevant rating: 0
- Positive rating: from +1 to +3

In the case of indicators with a large number of heterogeneous measurements, e.g. where both qualitative and quantitative definitions are present, it has proved necessary to define coefficients of homogenisation of data.

The results of the analysis have been proposed in summary graphs. The structure provides for a division into hinge areas, for which the results of the analysis of the status of the project and their superimposition in the form of a kiviati diagram are graphically displayed.

The analysis relating to all the hinge areas are put together and summarized in a graphic matrix in which, in addition to the comparison between “before and after” (from negative to positive / from positive to negative), comparisons based on spin are highlighted: the results show, in some cases, how in some areas the evaluation always remains of the same degree but undergoes a slight decrease in positive or negative.

Conclusions

The port reform has introduced new moments and tools to support dialogue and consultation between ports and local administrations. In the Strategic System Planning Document, a connecting element between port planning and territorial planning of large areas, the dialogue between administrations is addressed to the strategic choices regarding the perimeter and the redesign of urban spaces, defining long-term agreements. Such agreements can be facilitated if the products on which the dialogue is based are the result of detailed and rigorous analysis.

In the absence of specific guidelines and consolidated experience in this field, this research aims to define a method for the perimeter of port-city interaction areas. The method has made it possible to identify on which urban areas the port has the greatest influence and generates relationships, recognizing potential and criticality, measuring how much the factors belonging to the two areas are present and connected within.

The evaluation showed how marginal areas of the urban fabric, not considered by urban and port planning – or, in some, not considered in any planning tool – as an area of interaction, can actually reveal a high degree of influence: for the strong presence of functions belonging to one of the two areas, for the presence of promiscuous traffic, for the incongruous use of land, for the visual and landscape impact of infrastructure. The research has therefore made it possible to identify the forgotten, critical areas, those in which interaction is not yet controlled, on which it’s necessary to open a joint planning dialogue.

Secondly, the study of projects currently being implemented or planned in a future planning scenario has, in some cases, made it possible to confirm the willingness – on both institutional sides – to continue to plan interventions jointly: in these cases the projects are homogeneous and consistent with each other. However, the evaluation also finds cases where the agreements have not worked or have now been successful: some of the planned measures, although improving in some respects, may be worse for other or have a high impact. This shows that, in some areas where planning is not joint, it is necessary to share choices instead.

The proposed solution forms the basis on which the subsequent perimeter of the port-city interaction areas will take place, including in the new elaboration many areas that had previously been completely neglected in the pre-form PRPs. In fact, the analysis shows the need to widen the “joint planning perimeter”.

Of course, the proposed method doesn't have the ambition to propose itself as a single solution to the problem under study; however, it tries to demonstrate what a rigorous and coherent methodology could be, if amplified and applied to similar cases, to better management and shared planning.

Bibliography

- [1] Autorità di Sistema Portuale Mar Tirreno Settentrionale (2012) - *Piano Regolatore Portuale di Livorno*
- [2] Autorità di Sistema Portuale Mar Tirreno Settentrionale (2008) - *Piano Regolatore Portuale di Piombino*
- [3] Barbera, M. Morucci, F. (2017) - *L'apertura del porto alla città*, in Bicocchi, J. *Tra terra e mare. Dialoghi sul porto, oggi*, Milano: Franco Angeli.
- [4] Bigazzi, S. (2017) - *La strategicità della governance portuale: dalla frammentazione al nuovo assetto delle Autorità di Sistema Portuale. Criticità e prospettive alla luce della riforma*, in Rivista di Economia Politica e dei Trasporti
- [5] Carbone, S.M., Munari, F. (2019) - *I porti italiani e l'Europa*, Milano: Franco Angeli
- [6] Carbone, S. M., Munari, F. (2006) - *La disciplina dei porti tra diritto comunitario e diritto interno*, Milano: Giuffrè Editore.
- [7] Carlucci, F., Siviero L. (2016) - *La governance dei sistemi infrastrutturali tra centralizzazione e decentramento: il caso della riforma portuale in Italia*, in Rivista di Economia e Politica dei trasporti
- [8] Comune di Livorno (2018) - *Piano Strutturale 2*
- [9] Comune di Piombino (2005) - *Piano Strutturale d'Area della Val di Cornia*
- [10] D'Amora, S., Saponieri, A., Di Leverano, F., Curcutto, A.M. (2019) - *La riforma portuale e le innovazioni nella pianificazione: il caso di Bari*, Urbanpromo
- [11] Di Santo, P. (2003) - *Gli indicatori urbani per il monitoraggio della relazione città – area portuale*, Napoli: Giannini Editore
- [12] Di Venosa, M. (2006) - *L'interfaccia porto-città*, in Barbieri, P. (2006): *Infraspaazi*, Roma: Meltemi
- [13] Ministero delle Infrastrutture e dei Trasporti-MIT (2017) - *Piano Strategico Nazionale della Portualità e della Logistica*
- [14] Ministero delle Infrastrutture e dei Trasporti-MIT (2017) - *Connettere l'Italia. Strategia per le infrastrutture di trasporto e logistica*, Allegato DEF
- [15] Regione Toscana, MiBACT (2014) - *Piano di Indirizzo Territoriale con valenza di Piano Paesaggistico*
- [16] Rubecchini, P. (2017) - *Critica della ragion portuale: una prima analisi del D.Lgs. n. 169/2016*, in Giornale di diritto amministrativo
- [17] Pavia, R. (2018) - *Ripianificare i porti in La riforma dei porti. Opportunità per una rinnovata visione integrata tra logistica e pianificazione territoriale* a cura di Lombardini, G., in *Urbanistica Informazioni* 278-279, INU Edizioni

LE COSTE DEI NEBRODI TRA MOSAICO PAESAGGISTICO, BENI CULTURALI E CRITICITÀ COMPLESSE. VISIONI E SCENARI STRATEGICI PROGETTUALI NEL PARADIGMA DELLA SOSTENIBILITÀ

Andrea Marçel Pidalà

Università di Firenze

phone: (+39)392.8675374, e-mail andreamarcel.pidala@unifi.it

Abstract – The coastline that delimits and separates (or joins) the geographical area of the Nebrodi (Eastern Sicily) from (or with) the Mediterranean Sea, includes beaches, coastlines and areas now more or less urbanized along a border section of about 104 km. Along this coastline there are (mainly in a linear way) 15 urban centers going towards Messina-Palermo, and precisely they are: Oliveri, Patti, Gioiosa Marea, Piraino, Brolo, Naso, Capo d'Orlando, Torrenova, Sant'Agata di Militello, Acquedolci, Caronia, Santo Stefano di Camastra, Reitano, Motta d'Affermo, Tusa, all falling (due to administrative competence) in the Metropolitan City of Messina. The composition of the coastline is divided into three macro dimensions: 1) the beaches (understood as the space that includes the movement of the sea); the dunes (intended as the most natural space and not directly touched by the movement of the waves but where there are valuable environmental assets); the "waterfront" (which instead reflects the composition and organization of human activity eg infrastructure, building, landscape, ...). Thus it is possible to clearly understand that the coastline defines a "wider" territory that has its own complexity where natural activities (eg the water cycle) and human activities (eg building constructions) intertwine and develop giving different shape to the places. However, in this mosaic the peculiar relationship between man and nature emerges, a relationship that has not always guaranteed, in recent years, the right balance of the two dimensions and has increasingly raised environmental criticalities (with negative effects also on human activities) that they require strategic and structural interventions according to a holistic and / or integrated vision. In this sense the progressive urbanization of the coastal areas (often pushed up to the shoreline and even to the river beds) with coastal roads, second homes, tourist villages, purifiers, ... (now a common situation in Italy) has produced the real stiffening of the coastline and questioning of ecological cycles. In this framework it is necessary to start again with new visions and scenarios (for the Nebrodi coasts) that have their own foundation in the sustainability paradigm.

Context

Molte delle regioni costiere del nostro Paese seppur oramai inglobate nell'urbanizzazione strisciante lungo i fronti a mare contengono alcuni tratti tra i più interessanti dal punto di vista paesaggistico e di valore storico naturalistico di tutto il Mar Mediterraneo. Muovendo dalla considerazione di cui sopra viene inquadrato il tema della proposta di questo *paper* che ha come *focus* le aree costiere dei Nebrodi.

Il territorio dei Nebrodi in tutta la propria complessità ed estensione si prospetta oggi come una ‘bioregione’ contenitore di biodiversità presente in modo articolato all’interno di un territorio molto più vasto che ricade, in Sicilia, tra i territori di Messina, Catania ed Enna ed in posizione panoramica significativa, con alle spalle l’Etna e di fronte le Isole Eolie patrimonio dell’umanità¹. Il *sistema costiero dei Nebrodi* si affaccia sul Mar Tirreno per una lunghezza complessiva del tratto costiero di circa 105,28 km, da est ad ovest comprende i Comuni di: Oliveri, Patti, Gioiosa Marea, Piraino, Brolo, Naso, Capo d’Orlando, Caprileone, Torrenova, Sant’Agata di Militello, Acquedolci, Caronia, Santo Stefano di Camastra, Reitano, Motta d’Affermo e Tusa. Il paesaggio delle coste è contraddistinto da golfi, foci fluviali, promontori, scogli, punte e insenature – è costituito in generale da costa bassa e ciottolosa intercalata da brevi e stretti litorali sabbiosi e da alti promontori rocciosi contraddistinti da singolarità geologiche e su cui allignano specie rupicole endemiche di levante interesse scientifico. Il *versante tirrenico* (ovest) che si articola lungo la statale 113 (che arriva sino alle porte di Palermo) dalla città di Messina toccando i centri maggiori come Villafranca Tirrena, Milazzo, Patti, Capo d’Orlando, Sant’Agata di Militello sino ai centri urbani medio-grandi quali Caronia, Santo Stefano di Camastra, Tusa ed è connotato da una dimensione territoriale di grande valenza macro-geografica ed eco-paesaggistica essenzialmente



Figura 1 - Linee Guida per la formazione del Piano Territoriale Strategico del Biodistretto dei Nebrodi estratto dalla Tavola n.3 Il Sistema delle coste.

Figure 1 - Guidelines for the Formation of the Strategic Territorial Plan of the Nebrodi Biodistrict, extracted from Table 3 of the Coastal System.

¹ Lo spazio geografico risulta tuttavia composito sotto diversi profili per la sua struttura ecologica, paesaggistica e urbanistica, un unicum distinto dalla presenza del *Parco Regionale Naturale dei Nebrodi*; un mosaico culturale di rilevante bellezza composto dalle fasce dell’agrumeto, dell’uliveto, del nocciolo e del castagneto; dall’articolata presenza di centri costieri, collinari e montani, con rilevanti presenze di beni etno-antropologici e beni culturali isolati e aggregati ricchi di bellezza e suggestione; la presenza di centri urbani polarizzanti, per beni e servizi materiali, d’interesse per l’area anche più vasta.

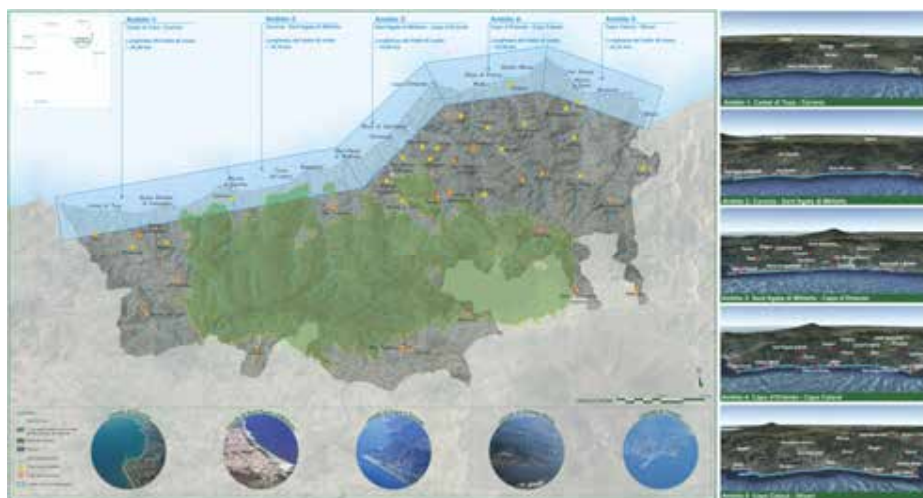

Figura 2 - Tratto costiero all'interno del Comune di Capo d'Orlando (Baia di San Gregorio).
 Figure 2 - Coastal stretch in Capo d'Orlando Municipality (bay of San Gregorio).

riconducibile ad alcune reti urbane policentriche e tre macro-sistemi territoriali ambientali. Particolare suggestione ancora oggi è offerta dall'arcipelago delle *Isole Eolie* che si trova posizionato a nord della costa tirrenica - proprio di fronte all'area dei Nebrodi- meta e riferimento di tanti leggendari viaggiatori² che offrono il loro teatro naturale derivante dal parossismo tardo pliocenico e pleistocenico. Le Isole Eolie sono raggiungibili mediamente tra i 25 e i 45 minuti di barca dai centri portuali di Milazzo, Capo d'Orlando e Sant'Agata di Militello³.

Il tratto costiero è compreso nella Bioregione dei Nebrodi a cui si fa qui riferimento è qui distinto in tre unità fisiografiche individuate dal PAI⁴ e più segnatamente:

- ***l'unità fisiografica n.19***, che si sviluppa da ovest verso est dal porto di Cefalù fino a Capo d'Orlando, per una lunghezza totale di 75,638 km circa e ricade lungo il litorale settentrionale tirrenico della Sicilia, comprendendo sia territori appartenenti alla provincia di Palermo che alla Città Metropolitana di Messina. Che raggruppa amministrativamente i Comuni di Tusa, Motta d'Affermo, Reitano, S. Stefano di Camastra, Caronia, Acquedolci, S. Agata di Militello, Torrenova, Capo d'Orlando.
- ***l'unità fisiografica n.20*** che si sviluppa da ovest verso est da Capo d'Orlando a Capo Calavà, per una lunghezza totale di 17,820 km circa e ricade lungo il litorale settentrionale tirrenico della Sicilia, comprendendo territori appartenenti alla Città Metropolitana di Messina. Comprende amministrativamente i comuni di Capo d'Orlando, Naso, Brolo, Piraino e Gioiosa Marea, appartenenti alla provincia di Messina, di questi due sono rivieraschi: Brolo e Gioiosa Marea, gli altri si trovano nell'immediato entroterra ma presentano frazioni costiere.
- ***l'unità fisiografica n.21*** ricade interamente nel perimetro amministrativo della Città Metropolitana di Messina ed è localizzata nella porzione nord-orientale della Sicilia tra Capo Calavà a ovest e capo Milazzo a est. Il litorale, che si sviluppa per una lunghezza totale di circa 51 km, presenta per il 41 % coste basse (di cui circa il 28 % è costituito da

² Ne sono esempio alcuni autori come *A. Dumas (padre), J.W. Goethe, J.P. Houel, L. Spallanzani, Guy de Maupassant*; esclusivamente a titolo di esempio si veda: Maupassant G., 1998, *La Sicilia 1885, Diario di Viaggio*, Pietro Vittorietti e Dumas A., 1854, *“Impressions de voyage”*. Le capitaine Arena, Paris.

³ Le isole sono raggiungibili con traghetto o aliscafo anche da centri più grossi come da Cefalù, Vibo Valentia, Messina, Palermo, Reggio Calabria, Tropea, Napoli.

⁴ Cfr. Il Piano di Assetto Idrogeologico della Regione Siciliana in <http://www.sitr.regione.sicilia.it/pai/>

sabbia mista a ciottoli e il 72 % da ciottoli) e per il 59 % coste alte rocciose. Da un punto di vista amministrativo, l'unità fisiografica 21 comprende un totale di 8 comuni ricadenti tutti nella provincia di Messina, ma quelli interessati nella Bioregione dei Nebrodi sono Gioiosa Marea, Patti e Oliveri.

Valori

I valori di questo territorio sono identificabili scomponendolo almeno in tre macro aree così definite:

- *Il versante costiero tindarita* che si estende dal promontorio su cui si erge il Santuario del Tindari di Patti sino al promontorio (capo) Santuario di Capo d'Orlando. L'ambito è connotato da una struttura insediativa e morfo-paesaggistica più forte dove emergono le grandi vette solcate dai sistemi delle fiumare con caratteri fluvo-alluvionali, su cui si innestano i sistemi urbani di rango e centri storici minori distribuendo servizi (commercio e terziario) e patrimonio storico culturale (trascurato) che caratterizzano il sistema biologico delle comunità locali con i centri di Patti, Tindari, Gioiosa Marea, Sant'Angelo di Brolo, Montagnareale, Piraino, Brolo, Sant'Angelo di Brolo, Ficarra, Sinagra, etc;
- *Quella che si estende da Capo d'Orlando sino Sant'Agata di Militello*. Dal Monte di Capo d'Orlando i sistemi urbani e territoriali si diversificano molto e in particolare per la presenza di una quantità raccolta di centri storici minori (Naso, San Salvatore di Fitalia, Castell'Umberto, Tortorici, Galati Mamertino, Frazzanò, Longi, San Marco d'Alunzio, Alcara Li Fusi, Militello Rosmarino) e centri urbani di vasta influenza (Capo d'Orlando e Sant'Agata di Militello) i quali hanno sviluppato nel tempo robusti tessuti imprenditoriali producendo e diffondendo un sistema socio-economico di largo interesse creando un vero e proprio *milieu*;
- *L'area che si estende da Sant'Agata di Militello sino a Santo Stefano di Camastra, Tusa*. La struttura del paesaggio in questo ambito si avvicina ai versanti del palermitano caratterizzato da piane larghe e monti prospicienti, alternando nell'entroterra aree rigogliose di boschi (faggio e sughera) con terreni brulli e aridi nelle propaggini delle Madonie (le ultime propaggini di Caronia, Tusa, Castel di Tusa, la Valle dell'*Halesa*,...).

Criticità 1. L'erosione costiera

L'erosione della costa costituisce un serio problema per l'80% delle coste mondiali, non di meno per la maggioranza dei litorali italiani⁵ e da più di trent'anni anche dei centri dei Nebrodi interessati gravemente dal fenomeno. L'attività di attenzione da parte delle comunità dei Nebrodi su questo fenomeno è stata sempre molto alta e fornendo notevoli contributi di

⁵ Cfr. Dusi E., 2013, "*L'Italia delle coste perdute*", in R2, L'inchiesta, in Repubblica del 20.09.2013, La Repubblica; Bongiovanni M., 2019, "*L'erosione minaccia un terzo delle coste italiane*", in "LIFEGATE", website link: <https://www.lifegate.it/persone/news/erosione-coste-italiane>; <https://www.lanuovaecologia.it/clima-quasi-la-meta-delle-spiagge-si-sara-ritirata-entro-la-fine-del-secolo/?fbclid=IwAR3XQYPVaxmxRUJ7OCmDKFovxtlwomnfb54kf4TRCM-s4CDFBTMgsVRPkE>

studio e attenzione⁶ che hanno consentito di divulgare le giuste informazioni scientifiche unite a casi studio alimentando così ricerca e sperimentazione metodologica. In tanti anni di monitoraggio continui da parte dei comuni o delle associazioni ambientaliste locali si è giunti anche a diverse soluzioni che talora erano di tipo tecnologico⁷ o anche semplicemente tecniche più “*naturalistiche*”⁸, che ovviamente negli anni non hanno comunque prodotto grandi ricadute, per meglio dire senza grandi effetti di minorizzazione e contenimento del fenomeno nonostante una maggiore applicazione in questo territorio. In tal senso, spesso, estesi tratti di costa delle regioni costiere sono protetti con opere rigide e le regioni adriatiche centrali sono quasi completamente protette da opere di difesa radenti la riva o distanti fino ad alcune centinaia di metri⁹. In questa bioregione molti sono stati i Comuni costieri, che dalla fine degli anni settanta, sono stati gravemente colpiti e nella fattispecie: Patti, Gioiosa Marea, Brolo, Capo d’Orlando e Sant’Agata di Militello hanno avuto negli anni forti. Nonostante numerose soluzioni tampone adottate nel corso del tempo essendo il fenomeno dell’erosione di tipo ciclico, spontaneo e molto complesso¹⁰ ha trovato nel corso degli anni ostacoli¹¹ lungo il litorale sottoposto alla sua azione ha acuitizzato i suoi effetti successivamente interessando a catena per molti chilometri di costa. Recentemente, anche su sollecitazione di alcuni attori sociali¹², la Regione Siciliana ha formulato, proposto e fatto aderire i Comuni dei Nebrodi alla condivisione del “*Contratto di Costa*”¹³ che in due anni pare abbia elaborato¹⁴ - muovendosi in riferimento con le “*Linee guida nazionali per la difesa della costa dai fenomeni di erosione e dagli effetti climatici*”¹⁵ - un proprio piano operativo¹⁶

⁶ Cfr. <http://www.erosionespiagge.eu/elencocontenuti.aspx?id=333&tipo=icomuni>

⁷ Per esempio i famosi *pennelli* (consistenti in mucchi di pietre o moli artificiali perpendicolari alla costa); le *scogliere aderenti* (consistenti in barriere di massi scaricate spesso ai piedi di strade, passeggiate, ferrovie e/o edifici); le *scogliere parallele* (consistenti in ammassamento di scogli paralleli alla spiaggia e spesso realizzati ad alcune decine di metri dalla costa); le *scogliere sommerse* (consistenti anche esse in ammassamento di scoglie paralleli alla spiaggia ma che non raggiungono la superficie dell’acqua).

⁸ In tal senso a metà degli anni novanta con supporto delle associazioni ambientaliste locali veniva promosso lo studio per il *ripascimento con sabbia* sui litorali che avevano perso ampi brani di dune. Veniva in tal senso elaborato uno studio di ripascimento costiero da uno studio ligure e che aveva sperimentato qualche iniziativa nelle coste liguri con risultati positivi.

⁹ Cfr. http://www.isprambiente.gov.it/files/pubblicazioni/statoambiente/tematiche2011/05_%20Mare_e_ambiente_costiero_2011.pdf

¹⁰ Tra le cause vanno annoverati i fenomeni di subsidenza dei fiumi (abbassandosi il livello del suolo di alcuni centimetri l’anno) in questo caso è acuitizzato anche dal fatto che i fiumi dei Nebrodi sono stati cementificati nel corso degli ultimi trent’anni; la presenza di alcune opere come i porti (spesso non completi) hanno contribuito a sbarrare il nastro trasportatore litoraneo; le mareggiate (l’onda lunga) che non trova il regolare deflusso per l’assenza delle dune costiere ridottesi notevolmente.

¹¹ L’urbanizzazione selvaggia (con la mancata pianificazione delle aree demaniali – con la corretta applicazione e attuazione dei PUDM- da parte della Regione Siciliana) ne è stata un forte componente.

¹² Cfr. <http://www.erosionespiagge.eu/>; <https://www.youtube.com/watch?v=zhCw3SGdAXg>

¹³ Sottoscritto – a maggio 2018- tra il Presidente della Regione, il Commissario Straordinario di governo contro il dissesto Idrogeologico ed i Comuni compresi tra Tusa e Patti. Cfr. <http://www.regioni.it/dalleregioni/2018/05/03/sicilia-regione-erosione-spiagge-firmato-primo-contratto-di-costa-559593/>

¹⁴ Per un approfondimento si veda: <https://www.lasicilia.it/news/cronaca/329615/erosione-delle-coste-un-piano-della-regione-in-quattro-mesi.html>;

¹⁵ Cfr. <http://www.erosionecostiera.isprambiente.it/linee-guida-nazionali>

¹⁶ Un ulteriore consultazione mediante il website link:

http://www.regione.sicilia.it/delibereguinta/file/giunta/allegati/N.074_%2027.2.2020.pdf

per le coste siciliane il piano oltre a muoversi sul monitoraggio a tappeto delle coste dell'Isola individuerà priorità e tipologia degli strumenti da adottare per i casi rilevati.

Criticità 2. I fenomeni di tendenziale “conurbazione” lungo la costa tirrenico-nebroidea

Il fenomeno della città diffusa è stato più volte analizzato da Francesco Indovina¹⁷ per le aree centro-nord del nostro Paese (nondimeno si evidenzia una notevole diffusione urbana anche in Sicilia) hanno offerto “terreno fertile” alla localizzazione. Gli effetti di questa massa urbana ibrida sono definiti da Stefano Boeri¹⁸ come “l’anti-città” e non ha risparmiato nessuna parte del territorio italiano e delle realtà regionali. L’antropizzazione delle coste è da molti anni in atto lungo la fascia Tirrenico-Nebroidea (ovvero prendendo in considerazione il tratto costiero -direzione Messina-Palermo- e più precisamente dal promontorio di Capo d’Orlando sino al Porto di Sant’Agata di Militello) ed è avvenuto spesso con la complicità pesante dell’urbanizzazione selvaggia della costa, ove segnatamente si sono sviluppati i centri urbani costieri certamente più consistenti per numero di abitanti¹⁹ e che durante le rapide crescite socio-demografiche hanno dato luogo in molti casi a delle conurbazioni che tendono a saldare i tessuti urbani in continuità disordinata di masse edilizie (non è un fenomeno raro è vero ma non è neanche un percorso corretto) lungo la piana costiera. Ciò ha avuto inizio a livello europeo - come ci ricorda Leonardo Benevolo²⁰ - tra la fine dell’ottocento e gli inizi del novecento poiché grazie alla realizzazione della ferrovia, alla forza lavoro (dovuta ai processi di spostamento della popolazione) e presente nelle città e nei centri urbani la crescita aumenta in modo esponenziale. Nel caso della bioregione dei Nebrodi la pianura si è offerta e ancora oggi si offre in modo favorevole per le attività commerciali e la crescita economica, su cui tendono ad espandersi le attività edilizie con una lenta ma intensa fagocitazione dei brani naturali costieri²¹. Considerando l’evoluzione urbanistica del centro di Capo d’Orlando²², oggi risulta il centro più attrattivo di tutto e anche quello che ha il più ampio territorio pianeggiante di affaccio litoraneo²³ dalla linea morfologica del “Capo” (da Messina a Palermo) non è difficile immaginare una possibile saldatura (in avvenire) con la frazione di Rocca di Caprileone e il centro urbano di Torrenova dando vita nei decenni in avvenire ad una potenziale “area metropolitana²⁴”.

¹⁷ Cfr. Indovina F., 2009, “Dalla città diffusa all’arcipelago metropolitano” ASUR, FrancoAngeli, Milano.

¹⁸ Cfr. Boeri S., 2011, “L’anticittà”, Laterza, Roma.

¹⁹ Capo d’Orlando contiene circa 14.000 abitanti (che durante il periodo estivo superano abbondantemente i 50.000) e Sant’Agata di Militello che contiene circa 16.000 abitanti ma è il centro di servizi di rango (es. Ospedale, Agenzia delle Entrate, Sede di Tribunale, Sede de Vigili del Fuoco).

²⁰ Cfr. Benevolo L., 1968, “Le origini dell’urbanistica moderna”, Laterza, Bari.

²¹ Cfr. Talia M., 1998, “L’urbanistica nelle città del Sud”, Cangemi, Roma.

²² Sidoti Migliore S., 1985, “Storia “Storia urbanistica di un territorio - Formazione di Naso e costituzione di Capo d’Orlando”, Ed. Pungitopo, Patti.

²³ Sardo Infirri V., 1981, “Realtà geografica della piana di Capo d’Orlando nel mondo antico”, Luglio-Agosto, Proloco, Capo d’Orlando.

Cfr.: <https://archeoclubcapodorlando.wordpress.com/2010/11/17/realta-geografica-della-piana-di-capo-dorlando-nel-mondoantico-di-v-sardo-infirri-lugli0-agosto-1981-pag-3-pro-loco-informazione/>

²⁴ Sui processi recenti di urbanizzazione delle aree costiere si rimanda al solido contributo di Giuseppe Trombino. Per un approfondimento si veda Trombino G., 2009, “Le coste siciliane tra sviluppo e sottosviluppo”, in Abbate G., 2009, “Territori Costieri”, FrancoAngeli, Milano.

In quest'ultimo caso se ciò potrebbe apparire troppo "visionario", avveniristico, troppo futuristico è invece una ipotesi molto probabile²⁵ se il modello di sviluppo non dovesse invertire chiaramente la sua rotta.

Visioni, Scenari e figure. Strategie e Azioni per le coste dei Nebrodi

Considerando la morfotipologia territoriale delle aree costiere dei Nebrodi occorre un intervento organico, complessivo di decongestionamento dall'antropizzazione, di alleggerimento da pressioni antropiche e regolamentazione di un uso diverso della costa che debba essere stabilito dalla *vision* e osservato dai singoli Comuni. Così oggi il sistema di governo del territorio e soprattutto delle coste (anche per via del sempre più evidente mutamento normativo ai vari livelli: Europeo, Nazionale e Regionale) assume il quadro degli eventi naturali e antropici come riferimento per la pianificazione delle interfacce demaniali tra il mare e la città in un paradigma di sostenibilità delle trasformazioni territoriali e ambientali. In tal senso l'erosione lungo i litorali dei Nebrodi si propone (al di là degli interventi rigidi già previsti o in corso di attuazione e diretti agli ambienti più fragili²⁶) che venga affrontata mediante una graduale rimozione dei detrattori costieri sia negli specchi d'acqua e sia sulle dune consolidate. Bisognerà agire mediante una più equilibrata pianificazione urbanistica che tuteli assolutamente l'ambiente della fascia litoranea con i suoi apparati dunali, anche rispetto a progetti di strade e di altre opere di urbanizzazione, responsabili dell'irrigidimento della linea di costa e concause dell'erosione costiera²⁷. La Vision per la bioregione agisce mediante gli Scenari Strategici che articolano a livello locale le strategie, gli interventi e le azioni che possono declinarsi nel modo seguente:

1. **Chiari e condivisi indirizzi politici.** L'urbanistica come dice Francesco Indovina²⁸ possiede un sostanziale approccio politico ed in alcuni casi si trova l'esigenza di dare indicazione di scelta politica e rivolte alla risoluzione politica come in questo caso. Se nonostante vincolo edificatorio vi fossero una molteplicità di costruzioni irregolari e non si potrebbe intervenire solo con le demolizioni come è possibile arrivare ad una soluzione in quell'ambito? Semplicemente attraverso innanzitutto un salto culturale collettivo e in seguito con indirizzi politici, cambio di destinazioni d'uso, riconversioni. Molte delle coste infatti sono oggetto di un'urbanizzazione (legittima o meno) negli anni. In questo

²⁵ "Nel censimento del 1881 il borgo di Capo d' Orlando registrava 657 abitanti. Un sensibile spostamento di parte della popolazione attiva di Naso verso la costa, era incominciato subito dopo la costruzione della linea Ferroviaria di Capo d' Orlando dalla quale Naso, che sorgeva a 498 m s. l. m. rimaneva distante circa 14 km di strada carrozzabile. Questo fenomeno contribuì a trasformare in un vivace centro abitato la borgata già, esistente abitata da pescatori, e ultimamente da alcuni operai ferroviari". Sidoti Migliore S., idem.

²⁶ Il Governo della Regione Siciliana come è stato sottolineato sta agendo mediante strumenti diretti sulle aree puntuali che hanno avuto effetti erosivi. Cfr. <http://www.glpres.it/contratto-di-costa-oltre-3-milioni-di-euro-decreto-finanziamento-e-lotti-interessati>; <https://www.comune.capodorlando.me.it/home-2/1177-ripresi-i-lavori-a-san-gregorio-per-il-ripristino-del-muro-sul-lungomare-nella-prima-settimana-di-maggio-la-gara-per-il-ripascimento>.

²⁷ Virtuani P., 2020, "Cemento e barriere, l'erosione minaccia metà delle spiagge", in *Corriere della Sera*, del 22.07.2020.

²⁸ Il quale sostiene che "la scelta urbanistica debba essere considerata scelta politica tecnicamente assistita". Cfr. Indovina F., 2018, "Non tutte le colpe sono dell'urbanistica", in <https://www.casadellacultura.it/782/non-tutte-le-colpe-sono-dell-urbanistica>.

caso non rimane altro che bloccare la tendenziale attività edificatoria per evitare oltre all'ulteriore aggressione agli equilibri fisico-ecologici anche l'aumento del degrado del paesaggio e il conseguente degrado sociale. In primo luogo occorre salvaguardare gli spazi vuoti lungo costa (contenendo il consumo di suolo²⁹); proteggere la diversità ecologica degli ambienti marini; decongestionare il litorale attraverso un blocco alla tendenziale edificazione da prevedere uniformemente negli strumenti urbanistici dei comuni della costa. In particolare gli interventi sulla costa dovrebbero concretizzarsi individuando le aree libere costiere e definirne gli usi (ad esempio cercando di mantenere le piane agricole e/o riconvertendo il loro uso produttivo) questo può solo avvenire mediante Piani³⁰ che siano coordinati tra loro sotto un'unica visione più coraggiosa e che ponga -quella che Vezio De Lucia chiama- la "*linea rossa*"³¹ entro cui fermare e riordinare usi del suolo diversi da quello *sprawl* legale ed illegale oramai realizzato. La fascia costiera è tutelata dalla L.R.: 78/76 art.15 della Regione Siciliana, occorre il coraggio di non opporsi alla legge anzi di osservarla in modo ortodosso soprattutto da parte degli enti comunali e dei privati.

2. **Osservazione delle normative e controllo sulle attività**³². Appare evidente che questo in tipo di situazione è più difficile intervenire in maniera strutturale. Come si può fare? Solo attraverso l'abbattimento continuo di fabbricati edilizi? È quasi totalmente impossibile e come si è visto le risposte di una pubblica amministrazione in termini di azioni realmente "praticabili" e con le relative conseguenze non sono state molto felici³³. Probabilmente occorre innanzitutto intervenire con una norma più attuale e coordinata con gli strumenti pianificazione a scala locale e sovra – comunale con il fine ultimo di evitare che il processo edificatorio si estenda all'infinito ed in maniera diseguale³⁴. Sicuramente occorre apporre una tutela più chiara e avviare un controllo diretto sulle attività edilizie private (che si intenderanno intraprendere) con la verifica e l'osservazione da parte degli abitanti delle azioni intraprese³⁵.
3. **Riprogettazione eco-strutturale ed estetico-paesaggistico di qualità dei luoghi**. In questo quadro complessivo occorre un intervento massiccio di riprogettazione (con

²⁹ Cfr. <https://www.snpambiente.it/2019/09/17/consumo-di-suolo-dinamiche-territoriali-e-servizi-ecosistemici-edizione-2019/>

³⁰ Il "governo" delle aree costiere demaniali, soprattutto in Sicilia, ha sempre destato attenzione per essere un nodo critico, nella disciplina della pianificazione del territorio. In questo caso le competenze della Regione Siciliana sono di almeno tre tipi gli strumenti di pianificazione certamente il più diretto è il Piano di Utilizzo del Demanio Marittimo (PUDM) ma che dovrebbe raccordarsi con il Contratto di Costa, con il Piano Territoriale Paesaggistico d'Ambito (PTP), con lo strumento urbanistico generale (PRG) e con il Piano di Assetto Idrogeologico (PAI).

³¹ Cfr. De Lucia V., 2015, "*La città dolente*", Castelvecchi, Roma.

³² In tal senso esistono due norme fondamentali nella Regione Siciliana orientate alla conservazione delle coste: l'art. 15 della L.R. 78/76 ed s.m.i. e il Codice dei Beni Culturali e del Paesaggio 4/2008 ed s.m.i.

³³ Le vicende tristemente note in Sicilia fanno ben capire che la soluzione non è facilmente praticabile dalle amministrazioni locali. https://www.ansa.it/sicilia/notizie/2016/05/30/abusivismo-ruspa-in-valle-dei-templi_97eaa538-f313-44a1-8bc5-17352a90a006.html

³⁴ Occorre verificare e porre in essere gli interventi strutturali a mare (ad esempio con rinascimenti a materiale idoneo) e con l'adozione di strumenti di monitoraggio e di manutenzione ambientale delle spiagge. In tal senso occorrono interventi mirati alla difesa del litorale che non dovranno essere posti ad libitum ma adeguatamente studiati e inseriti nel contesto paesaggistico.

³⁵ Negli anni ci sono state diverse proposte di Legge per le Coste Siciliane ma ancora oggi nessuna novità è stata posta in essere.

microprogettazione di dettaglio) e di riqualificazione complessiva – dei luoghi intervenendo su due principali fronti: il primo in ordine alle strutture ecologiche delle zone costiere in secondo luogo in termini estetici sulle presenze antropiche. Si ritiene fondamentale una solida e puntuale analisi (per contesti e ambiti studiati *ad hoc*) che sia propedeutica al ripristino di un certo equilibrio messo alla dura prova con l’aggressione anche delle dune, degli spazi filtro tra l’ambiente naturale e l’ambiente antropizzato. Si necessita oltre ai progetti di “consolidamento” di progetti di rinaturalizzazione in ambiti territoriali di pregio, interventi per la riscoperta della presenza idrica³⁶ nei contesti urbani – con il ripristino di canali e manufatti idraulici, il ridisegno complessivo dei *waterfront*³⁷ considerando anche gli apparati paesistici. Occorre anche un grande piano complessivo³⁸ di ri-progettazione del patrimonio edilizio³⁹ abusivo non sempre facilmente rimovibile e con la conseguente riconversione complessiva dei manufatti ad uso collettivo.

Riferimenti bibliografici

- [1] Carta M., 2007, *“La sottile linea blu. Inseediamento costiero e progetto di territorio. Il caso gallurese”*, CUEC, Cagliari.
- [2] De Lucia V., 2015, *“La città dolente”*, Castelvecchi, Roma.
- [3] Indovina F., 2018, *“Non tutte le colpe sono dell’urbanistica”*, in <https://www.casadellacultura.it/782/non-tutte-le-colpe-sono-dell-urbanistica>.
- [4] Magnaghi A., 2011, *“La via pugliese della pianificazione al paesaggio”*, in Urbanistica n.147, INU ed., Roma.
- [5] Mostafavi M., Doerthy G., 2016, *“Ecological Urbanism”*, Revised, Germany.
- [6] Salzano E., 2013, (a cura di), *“Lezioni di piano. L’esperienza pioniera del piano paesaggistico della Sardegna raccontata per voci”*, Corte del Fontego, Venezia
- [7] Teti V., 2003, (a cura di), *“Storia dell’Acqua. Mondi materiali e universi simbolici”*, Donzelli, Roma.
- [8] Virtuani P., 2020, *“Cemento e barriere, l’erosione minaccia metà delle spiagge”*, in *Corriere della Sera*, del 22.07.2020.
- [9] <http://www.glpres.it/contratto-di-costa-oltre-3-milioni-di-euro-decreto-finanziamento-e-lotti-interessati/>;

³⁶ Cfr. Teti V., 2003, (a cura di), *“Storia dell’Acqua. Mondi materiali e universi simbolici”*, Donzelli, Roma.

³⁷ Sono stati elaborati, in occasione della *Global Conferenze on the Urban Future* (URBAN 21) tenutasi a Berlino nel 2000, i principi per uno sviluppo delle aree di *“waterfront urbano”* che si ritengono utili al fine della riprogettazione degli ambienti costieri. Un ulteriore interessante approfondimento si rimanda alla ricerca condotta da Massimo Carta sulle coste della Sardegna, per un approfondimento si veda Carta M., 2007, *“La sottile linea blu. Inseediamento costiero e progetto di territorio. Il caso gallurese”*, CUEC, Cagliari.

³⁸ Molto interessanti risultano le esperienze condotte in contesto di pregio come la Sardegna e la Puglia. Per un approfondimento si veda Salzano E., 2013, (a cura di), *“Lezioni di piano. L’esperienza pioniera del piano paesaggistico della Sardegna raccontata per voci”*, Corte del Fontego, Venezia; Magnaghi A., 2011, *“La via pugliese della pianificazione al paesaggio”*, in Urbanistica n.147, INU ed., Roma.

³⁹ Per quanto riguarda i progetti di dettaglio appaiono molto interessanti le recenti esperienze di *“Ecological Urbanism”* portate avanti da alcuni progettisti in ambito internazionale. Per un approfondimento si veda la raccolta di progetti e sperimentazioni di Mostafavi M., Doerthy G., 2016, *“Ecological Urbanism”*, Revised, Germany.

- [10] <https://www.comune.capodorlando.me.it/home-2/1177-ripresi-i-lavori-a-san-gregorio-per-il-ripristino-del-muro-sul-lungomare-nella-prima-settimana-di-maggio-la-gara-per-il-ripascimento>
- [11] <https://www.snpambiente.it/2019/09/17/consumo-di-suolo-dinamiche-territoriali-e-servizi-ecosistemici-edizione-2019/>
- [12] https://www.ansa.it/sicilia/notizie/2016/05/30/abusivismo-ruspa-in-valle-dei-templi_97eaa538-f313-44°1-8bc5-17352°90a006.html

SALERNO: IL PORTO E LE METAMORFOSI DEL *WATERFRONT*

Maria Russo

Università della Campania “L. Vanvitelli”

Tel.: 339 7269463 e-mail: mariaarchetta.russo@alice.it

Abstract - The port of Salerno, one of the largest on the Tyrrhenian coast, was implanted in the Middle Ages west of the city. Deteriorated over time due to neglect and serious problems of cover-up afflicting the area, it was uselessly renovated in 1752 and replanted after the unification of Italy, creating a closed basin with the mouth turned to the east. The wrong orientation and the massive landfill phenomena supervening, led to the severe erosion of the eastern beach, on which it stood the city. In order to cope with the phenomena, in the last decades of the nineteenth and early twentieth centuries, multiple defense interventions were carried out by sheltered cliffs that filled the coast with the total metamorphosis of the coastal strip. The operations were managed through a special regulatory plan, which regulated the use of the resulting soils, on which the main public buildings and private were built. A coastal road was built at the service of the new settlements, on which, with particular commitment, the railway line that connected the port to the railway was laid, placed at the opposite end of the city.

Introduzione

Il presente scritto è l'anticipazione di un ampio studio sulle metamorfosi della fascia costiera urbana di Salerno tra tardo Ottocento e primo Novecento, tema che impegnò la classe professionale locale per decenni. Tralasciando la gran mole di progetti - quasi tutti rimasti sulla carta - in queste brevi note si propone una riflessione sugli elaborati maggiormente significativi, la cui realizzazione è all'origine dell'odierno assetto.

Salerno si estende nel sito più interno dell'omonimo golfo, nel punto in cui i rilievi della Penisola Amalfitana cedono il posto alle aree pianeggianti che convergono verso la valle del Sele, con un litorale rivolto a sud sud-ovest e particolarmente esposto a forti correnti, con venti dominanti del II e III quadrante. Il settore a valle del centro storico, titolato Lungomare Trieste, costituisce un'amena e panoramica passeggiata, affacciata direttamente sul mare e corredata di ampi spazi verdi, al di là dei quali corre la strada delimitata da palazzi ascrivibili prevalentemente alla prima metà del XX secolo. La condizione, chiaramente non naturale, come suggerisce la totale assenza della spiaggia, limitata ad un esiguo tratto sul margine occidentale di S. Teresa, è frutto delle massicce colmate, ideate sul finire del XIX secolo e realizzate nei decenni successivi, per ovviare a gravi problemi di erosione del lato orientale, dotando nel contempo la città di ulteriori suoli edificabili.

La vicenda è estremamente complessa ed articolata e viene ricomposta in questa sede, grazie al reperimento di inedite fonti documentarie esistenti presso l'Archivio storico del Comune - promotore delle opere - e la sede picentina dell'Archivio di Stato.

Nel XIII secolo, a ponente dell'abitato, fu impiantato il porto, costituito da un molo perpendicolare al lido e staccato da esso che, resosi nei secoli inutilizzabile per l'assenza di

cure e l'interramento a cui era soggetto, fu ripristinato nella seconda metà del Settecento, chiudendo il varco ed aggiungendovi un braccio ortogonale, con esiti disastrosi. Nel 1861 venne avviata la costruzione di un ancoraggio, ideato dall'ingegnere di Ponti e Strade E. Lauria e realizzato, in forme minori, dall'ingegnere G. Palmieri, dirigente dell'Ufficio del Genio Civile della Provincia. L'opera consistette in una banchina isolata curvilinea parallela alla spiaggia, che si spingeva per 300 metri verso ovest dalla testata della preesistente, che, in riferimento all'epoca di formazione, è a tutt'oggi nota come molo Manfredi [5, 6].

Fin dal primo momento, il manufatto incise profondamente sul regime delle correnti, peggiorando le condizioni di accumulo e sottrazione dei materiali, in quanto le ondate provenienti da diverse direzioni vi impattavano e rimbalzando si sommarono tra loro colpendo obliquamente il litorale a levante e producendovi una significativa erosione. La circostanza oltre che destare preoccupazione negli abitanti degli edifici limitrofi, impensieriva soprattutto poiché la strada per le Calabrie - tracciata ad inizio Ottocento da Napoli a Nocera e da qui a Salerno, da dove proseguiva verso sud (attuale SS. n. 18 Tirrena inferiore) - correva proprio sulla spiaggia, retta da una muraglia separata dalla battigia da appena 7 metri. Infatti, si paventava che con il crollo della parete si interrompesse il transito sull'arteria, unico collegamento rotabile con le regioni meridionali.

I timori si avverarono nel 1872, quando furiosi fortunali abbattono per 500 metri il muro di contenimento, da poco rifatto, e dissestano gravemente i tratti adiacenti¹. Il maggiore danno si registrò in corrispondenza del palazzo della Prefettura - non lontano dal molo - dove la strada provinciale si allargava formando una terrazza sporgente e proseguiva poi con l'intestazione di corso Garibaldi, fiancheggiata da un ampio marciapiedi, divenuto un frequentato passeggiatoio sul mare, e da edifici sull'altro lato.

Le numerose proposte avanzate da tecnici consultati dall'amministrazione o presentatisi spontaneamente, nonché dall'appena costituito Ufficio Tecnico Comunale, furono tutte approssimativamente analoghe, improntate al rifacimento del muraglione più



Figura 1 - Progetto di una nuova banchina laterale al corso Garibaldi, ing. L. Casalbone, 1872 (ASCS).

Figure 1 - Project of a new side platform to the course Garibaldi, eng. L. Casalbone, 1872.

¹ ARCHIVIO STORICO DEL COMUNE DI SALERNO (ASCS), *Fondo Capone, Fald. 3; Cat. X, clas. XII, fascic. 125, "Spiaggia"*; ARCHIVIO DI STATO DI SALERNO (ASSa), *Prefettura I serie, b. 1724, fasc. 1*. La vicenda è costantemente richiamata negli atti consultati.

solido e con una sagoma utile a respingere meglio le ondate, proteggendolo con una scogliera da porre, secondo alcuni, a ridosso, secondo altri, al largo².

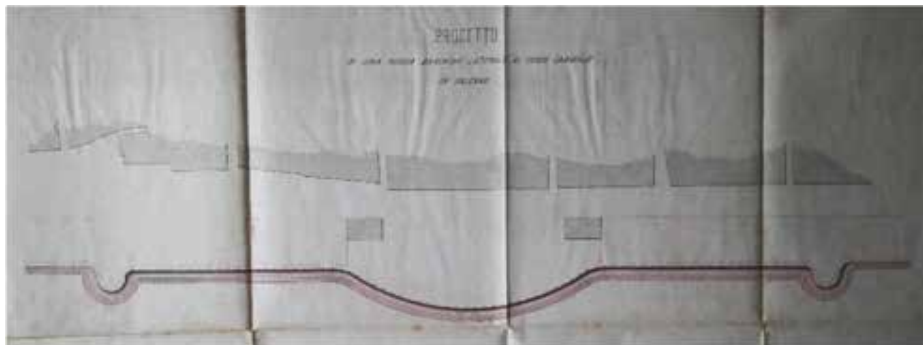
Interpellato il Genio Civile, l'ingegnere capo Michele Cervati, al momento impegnato nella realizzazione dell'attiguo porto, giudicò il sistema inutile e costoso e suggerì di ovviare all'inconveniente mediante la costruzione di pennelli, ovvero sbarramenti perpendicolari alla costa - già da lui attuati con successo in Liguria e in Sicilia - che, trattenendo il deflusso dei materiali, ne avrebbero favorito l'accumulo con conseguente ripascimento. Ulteriori problemi da affrontare consistevano nell'irregimentazione delle fognature che defluivano sull'arenile ristagnadovi e nel collegamento dello scalo alla linea ferroviaria, che comportava un binario di attraversamento dell'intera fascia costiera³.

Accantonati gli elaborati presentati, il Comune incaricò il tecnico di un apposito progetto, redatto nel 1875, basato sul sistema dei pennelli, la cui fattura poteva associarsi al prolungamento dei corsi luridi in mare aperto⁴. L'istanza era particolarmente sentita, in quanto gli sbocchi dei collettori continuamente danneggiati dalle onde, disperdevano i liquami sul lido dove si fermavano con grave pericolo per la salute pubblica. La sensibilizzazione, che assunse un ruolo prioritario nelle successive progettazioni, era chiaramente legata all'epidemia di colera che in quegli anni aveva colpito Napoli [2].

A margine della proposta, l'ingegnere avanzò il suggerimento personale di approfittare delle opere di bonifica della spiaggia per gettare le basi di un ampliamento della città che, nonostante l'incremento della popolazione verificatosi negli ultimi anni, restava circoscritta al tessuto medievale, in condizioni insalubri e con immobili poco decorosi alla luce dei moderni standard abitativi⁵.

Per la realizzazione ritenne utile impiantare l'argine a circa 70 m dalla sponda e riempire lo spazio con una colmata che avrebbe assicurato a valle del corso Garibaldi suoli edificatori serviti da una strada parallela alla riva che, dalla piazza antistante il Teatro comunale - che sorgeva alle spalle del porto - raggiungeva la stazione ferroviaria, dislocata nel 1866 all'estremo opposto. Il disegno, palesemente emulante quanto si preventivava per il quartiere partenopeo di S. Lucia [2], avrebbe assicurato nuovi e moderni fabbricati, corredati di spazi verdi ed ampie strade in proseguimento delle preesistenti.

L'amministrazione accolse queste indicazioni e bandì un apposito concorso pubblico, ponendo tre condizioni inderogabili: che quanto si andava a fare non interferisse con il porto, creando risacca a giro radente nell'avamposto, tale da compromettere il transito in caso di tempesta; che non si avanzasse in mare tanto da intercettare i natanti; che si risolvesse il problema delle fogne. Dei quattro elaborati presentati, valutati dall'ispettore del Genio Civile G.B. Fornari, nessuno soddisfece in pieno i presupposti, per cui furono chiamati gli ingegneri Enrico Amato e Filippo Giordano, che meglio avevano risposto alle istanze alla base della programmazione⁶, a collaborare nella redazione del piano di difesa della

² I vari progetti si devono agli ingegneri Fiocca, Zocca, Casalbone, Blanco (ASCS, *Fondo Capone*, Fald. 3; cat. X, cl. XII, fasc. 125).

³ Ivi, *Fondo Capone*, Fald. 3.

⁴ Ivi, *Relazione a corredo delle opere occorrenti per difendere dalle offese del mare la strada della marina (...) pel Cav. Michele Cervati Ingegnere Capo del Genio Civile*, Salerno 1875 (a stampa).

⁵ *Ibidem*.

⁶ Il tecnico fece un puntuale resoconto in un opuscolo a stampa (ivi, *Dell'ampliamento della città di Salerno e della difesa contro l'invasione del mare. Relazione*, Salerno 1888). Egli ritenne lodevole la soluzione ai problemi fognari proposta dall'Amato ed accurata e ben sviluppata la parte relativa all'espansione urbana fatta dal Giordano.

spiaggia e di ampliamento della città⁷. Questi prevedero una scogliera di protezione composta da tratti isolati, a circa 30 m dalla battigia, nonché la rinunione delle fogne in due ampi collettori da portare in mare aperto. Il piano era strettamente collegato ai lavori del porto che, nel frattempo, aveva visto l'aggiunta ad ovest del primitivo molo isolato di una banchina normale alla costa raccordata con un'ampia curva e, ad est, di un prolungamento rettilineo rivolto a S-E, che aveva definito una bocca d'ingresso rivolta a levante, in direzione delle maggiori correnti produttrici dell'insabbiamento del bacino interno e dello sgretolamento del lido. Inoltre, l'idea era subordinata agli impianti di supporto alle attività portuali (cantieri, magazzini, etc.) che si dovevano dislocare sulla contigua spiaggia di S. Teresa.

Il progetto, approntato nel 1889 e revisionato alla luce delle osservazioni mosse dal Consiglio Superiore dei Lavori Pubblici, fu varato, ma vide solo l'attuazione di qualche tratto di scogliera, nonostante avesse ottenuto anche dei sussidi statali.

Il progetto dell'ing. Alberto de Sanctis

Nel 1897, dopo diverse altre proposte cadute nel vuoto o rigettate dal Consiglio Superiore del Ministero LL. PP., si ebbe una definitiva idea di assetto da parte dell'ing. Alberto de Sanctis, direttore dell'Ufficio Tecnico Comunale, approvata e finanziata dall'organo centrale⁸. Nella relazione di accompagnamento il tecnico richiamò le passate vicende e le pressanti necessità di salvaguardia indotte dalla costruzione del porto riconosciute dagli stessi esperti del Genio Civile, impegnati nei lavori, e da avversi eventi naturali, che provocavano il continuo allagamento del corso Garibaldi, e come, in circa venti anni, si fosse realizzato solo uno sbarramento di scogli provvisorio annualmente rifiorito.



Figura 2 - Planimetria del porto di Salerno, ing. A. de Sanctis, 1897 (ASSa).

Figure 2 - Plan of the Salerno Harbour, eng. A. de Sanctis, 1897.

⁷ Ivi, cat. X, cl. XII, fasc. 128, "1887 Spiaggia Progetto e sussidi"; ASSa, *Prefettura I s.*, b. 1274.

⁸ Ivi, *Fald. 19 Urbanistica - Suoli demaniali*, "Progetto dell'ingegnere Alberto de Sanctis per la difesa e sistemazione della riviera della città di Salerno", 4-8-1897; cat. X, cl. XII, "Difesa e sistemazione della spiaggia 1897-1903"; "Spiaggia 2"; ASSa, *Prefettura I s.*, b. 1724, fasc. 1; *Genio Civile I*, b. 258.

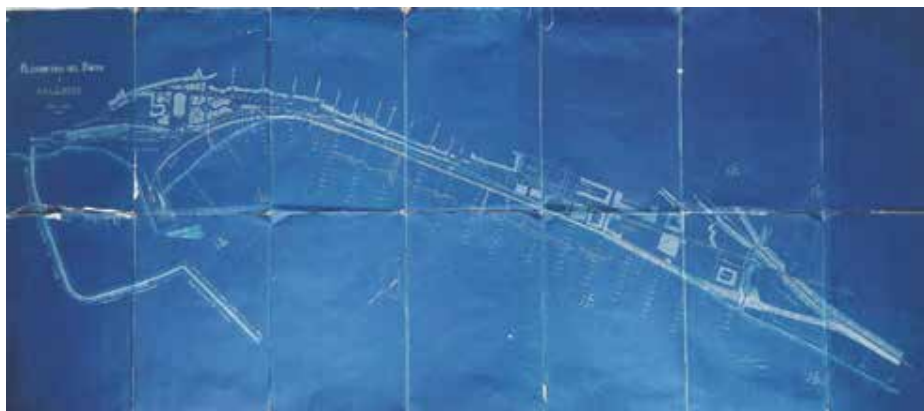
Il programma, ispirato a precise prescrizioni da parte del dicastero, prevedeva una scogliera frangionda di 700 m, frazionata in sette tratti distanti tra loro circa 40 m, paralleli al muro di riva, estesi tra la Prefettura e il gassometro, ed una gettata di massi naturali in aderenza per 100 metri a ovest e circa 550 ad est. Alla strada lungomare, tracciata tra la piazza del Teatro ed il mercato ortofrutticolo, si affiancava la piattaforma per il binario ferroviario a scartamento ordinario, oggetto di uno specifico accordo con la Società Italiana Ferrovia Mediterranea. Le rotaie si innestavano alla linea Salerno-Eboli prima della stazione, percorrevano diagonalmente la “Piazza d’armi”, giungendo al torrente Irno, che andava scavalcato con un ponte di 15 m a struttura metallica poggiante su piloni in muratura, e proseguiva sul litorale protetto da una gettata di scogli fino alla via litoranea, sul cui margine esterno correva su una piattaforma di 5 m. Il passaggio sul corso d’acqua imponeva la regolarizzazione della foce, composta da due rami che si espandevano sull’arenile⁹.

La strada si allargava in due piazze, una rettangolare davanti alla Prefettura; l’altra all’estremo orientale, era di forma semicircolare, circondata da giardini e innestata al corso Garibaldi con un’ampia traversa centrale e due laterali. Le fogne, riunite in due condotti, venivano prolungate, sboccando in mare aperto. Il progetto venne approvato dal Ministero dei LL. PP. per il tratto centrale, rimandando i rimanenti ad ulteriori piani particolareggiati.

Fin dal 1901 si tentò inutilmente di appaltare i lavori, avviati solo nel 1905. Si iniziò con la costruzione delle cinque dighe previste in massi artificiali con nucleo di pietre sciolte, distaccate tra loro, ma già in corso d’opera le strutture si rivelarono carenti, con conseguenti vortici ed escavazioni nelle testate in occasione delle mareggiate. Perciò si decise di usare esclusivamente blocchi artificiali e di riempire le intercapedini, formando un’unica chiusura, prima fino al livello del mare, poi al di sopra¹⁰.

Il piano regolatore dei suoli di risulta dell’ing. F. Colamomico

Nel 1907 venne approvato il piano regolatore del porto, inserito tra quelli stabiliti dalla commissione ministeriale istituita nel 1904¹¹. Si prevedeva il prolungamento del molo foraneo di levante di 100 m e la costruzione, all’estremo orientale, oltre la prima scogliera, di un lungo molo frangiflutti di 1300 m orientato da NO a SE, che andava ad incontrare l’opposto, definendo un’imboccatura di 250 m rivolta a sud e chiudendo l’intero litorale urbano nel bacino portuale¹².

L’ambizioso progetto, rimase inattuato e fu limitato al tracciamento di un breve pennello in corrispondenza dello spazio che anni dopo fu convertito nell’attuale piazza Concordia¹³. All’epoca, erano stati parzialmente costruiti il muro di riva e l’argine per la ferrovia e prolungati i collettori fognari con la direzione dell’ingegnere di 1° classe del Genio Civile Franklin Colamomico, nominato capo dell’Ufficio speciale per la difesa della spiaggia¹⁴.

⁹ La rettifica della foce fu concessa con decreto del 25-8-1905 (ASCS, cat. X, cl. XII, fasc. 128).

¹⁰ Nel marzo 1908 l’ing. Colamomico redasse i progetti suppletivi per la variazione del nucleo e la chiusura delle intercapedini (ivi, cat. X, cl. XII, fasc. 231(1) e 128, “1905 Spiaggia Moli frangiflutti”).

¹¹ D. R. 26-9-1904, n. 713, Approvazione del regolamento per la esecuzione della legge sui porti, spiagge e fari del 2-4-1885, n. 3095.

¹² ASCS, cat. X, cl. XII, fasc. 127, “Opera della spiaggia”; cat. X, cl. XII, “Spiaggia. Fornitura scogli”.

¹³ Ivi, cat. X, cl. XII, fasc. 128, “1914. Spiaggia Pennello orientale”.

¹⁴ Ivi, “1903. Spiaggia sussidi”.

Dal momento che si voleva includere le opere in atto nel disegno ministeriale¹⁵, nel 1908, si incaricò il tecnico della redazione di un piano regolatore che contemplasse l'ampliamento della città sulle superfici risultate dalle colmate che si contava di effettuare e della sistemazione degli arenili a ponente, prossimi al porto¹⁶.



Figura 3 - Planimetria del porto di Salerno, classificato in 2° categoria, ing. D. Lo Gatto, 1907 (ASCS).

Figure 3 - Plan of the Salerno Harbour, eng. D. Lo Gatto, 1907.

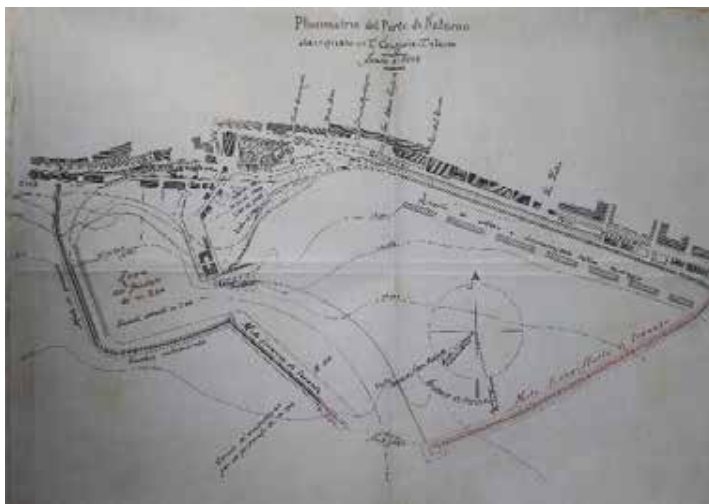

Figura 4 - Planimetria del litorale della città di Salerno. Piano regolatore dei suoli di risulta, ing. F. Colamomico (ASCS).

Figure 4 - Plan of the Salerno waterfront, eng. F. Colamomico.

¹⁵ Legge 14-7-1907, n. 542, “Provvedimenti per l’esecuzione di nuove opere marittime”, art. 14.

¹⁶ Cat. X, cl. XII, “Difesa della spiaggia Progetto del Corpo Reale del Genio Civile, ing. F. Colamomico 1910”; cat. X, cl. XII, fasc. 128, “1903 Spiaggia sussidi”.

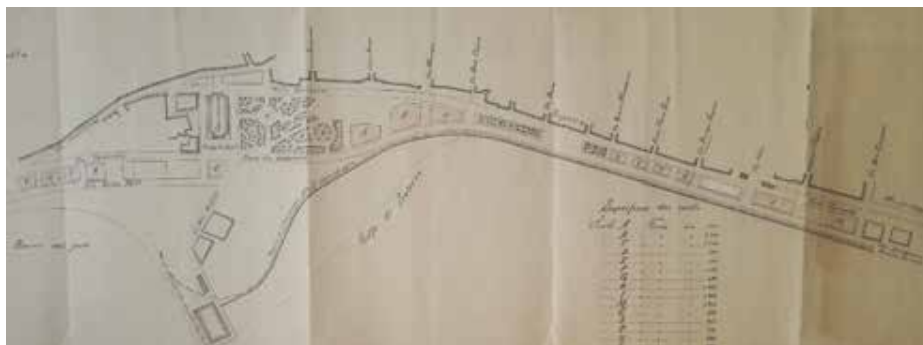
Il ruolo di centro direzionale del futuro sviluppo cittadino fu affidato al comparto occidentale, compreso tra il corso Garibaldi, il Teatro comunale, la via Lungomare e la Prefettura, al limite della spiaggia di S. Teresa, sulla quale dovevano sorgere le strutture di supporto alle attività portuali e mercantili, quali depositi, silos, cantieri, etc.

Le parti interessate furono frazionate in appezzamenti indicati con lettere dalla A alla V che avevano per fulcro, sul lato ovest, la vasta piazza (oggi G. Amendola) dal profilo mistilineo, ricavata allo sbocco del vico Breve (attuale vicolo Colonne), mentre, tra la Prefettura e la via dei Due Principati, si disponevano a valle del corso Garibaldi. Il piazzale, lastricato e dotato di ampi marciapiedi, aveva a ponente l'ingresso della villa comunale ed era delimitato a S-E dai lotti A e B, che con un terzo C definivano un settore triangolare esteso fino al vicolo Abate Conforti, chiuso a sud e a nord dal corso Garibaldi e dall'arteria litoranea. L'area verde, che presentava il profilo inferiore obliquo, veniva ampliata, in maniera da occupare completamente lo spazio tra i due tracciati, e riorganizzata nei giardini, nei percorsi e con l'inserimento di una cassa armonica.

Particolare rilievo assumeva la destinazione dei tre lotti prospicienti la piazza, dove si era pensato di adibire il centrale (B), più esteso, a sede del municipio o ad un uso promiscuo con istituti di credito o altro. Quanto ai rimanenti, si prevedeva di installare in (A) gli uffici delle poste - per cui esisteva un progetto - o qualche albergo, vista l'assenza in città di tali strutture e le richieste in merito legate al turismo verso la Costiera Amalfitana. L'ultimo avrebbe potuto accogliere una sala cinematografica in luogo delle arene da chiudere, presenti sulla spiaggia di S. Teresa, oppure il Comune con saloni per feste, concerti e conferenze nei piani superiori e circoli e clubs nell'inferiore.

Gli immobili dovevano essere disegnati da architetti di comprovata perizia ed approvati da un'apposita commissione per evitare disarmonie nelle forme, con rivestimenti in pietra o smalti simulanti superfici lapidee, atti a resistere all'aggressione marina. Al contorno dovevano avere ampi marciapiedi e porticati identici, larghi 5 m ed alti almeno 8 m, sul corso Garibaldi, mentre B e C si sarebbero collegati con un passaggio coperto vetrato a mo' di galleria. L'idea è chiaramente ispirata dalle recenti realizzazioni nelle principali città italiane e a Napoli, con le gallerie Principe di Napoli (1883) e Umberto I (1890) [2].

Inoltre, si prescriveva che gli ultimi piani fossero adorni di colonnine, loggiati, verde ed altri elementi decorativi¹⁷.



Figura 5 - Sezione, ing. F. Colamomico (ASCS).

Figure 5 - Section, eng. F. Colamomico.

¹⁷ L'altezza stabilita di 23 m fu contestata dal Ministero dell'Istruzione che, nel 1912, chiese che fosse ridotta a 18 m per non guastare la veduta dell'"insieme artistico e panoramico del luogo".

Al gruppo in questione seguiva una lunga aiuola rettangolare, estesa fino alla Prefettura, dove si interrompeva sullo slargo antistante, riprendendo dalla parte opposta con dimensioni minori. Successivamente si contavano otto unità edilizie (D-M) a sud del corso Garibaldi, fino al mercato ortofrutticolo, divise da strade intermedie e da altre in prosecuzione delle preesistenti. Le aree fabbricabili minori erano destinate ad accogliere piccoli immobili civili formati da pianterreno e due in elevazione, circondati da aiuole e passaggi alberati, mentre sulle maggiori si contava di innalzare cinque palazzine signorili.

Ad ovest del Teatro, la via Lungomare sfociava nella via Caracciolo, a sud della quale, prima del ricongiungimento con il corso Garibaldi si erano ritagliate altre cinque porzioni (Q, S, T, U, V), per le quali non furono date indicazioni, recependo quelle già comprese nel Piano regolatore compilato dall'Ufficio municipale dei lavori pubblici.

Ulteriori direttive sul da farsi emergono dal capitolato di vendita dei lotti, compilato dallo stesso Colamomico in vista delle aste pubbliche per le assegnazioni, i cui proventi avrebbero contribuito al finanziamento dell'iniziativa. Oltre ai detti vincoli architettonici, si imponeva agli acquirenti di avviare la costruzione entro sei mesi e concluderla entro tre anni, nonché a trasportare nelle colmate tutti i materiali di rifiuto, provenienti da scavi delle fondazioni e da demolizioni, secondo le norme stabilite dall'Ufficio Tecnico Comunale¹⁸.

Ispirato agli stessi criteri, ma con modalità diverse di attuazione è il piano presentato nel 1912 dall'ing. Luigi Centola, mai messo in pratica, il quale offrì una diversa soluzione per la medesima zona considerata dal Colamomico. Il tecnico, mentre riservò una distribuzione non molto difforme all'area ad oriente della Prefettura, allungando il verde e riducendo il numero delle zone edificabili, organizzò gli spazi ad ovest in maniera totalmente difforme. Innanzitutto spostò i giardini pubblici sulla parte triangolare, su cui si erano previsti la piazza ed i suoli A B C, e collocò al loro posto quattro stabili formanti una croce intorno ad un piazzale ad ottagono irregolare. In essi installò la sede comunale e l'ufficio delle poste,



Figura 6 - Progetto di sistemazione edilizia della zona litoranea della città di Salerno, ing. L. Centola, 1912.

Figure 6 - Town planning of Salerno waterfront, eng. L. Centola, 1912.

¹⁸ *Capitolato di vendita dei suoli di risulta (...)*, Salerno 1914 (opuscolo a stampa, ivi, *Fald. 19 Urbanistica*, "Suoli demaniali").

accessibili da est attraverso un ampio porticato voltato e collegati da una galleria vetrata, e negli altri due un “Grand hotel” e la “Cassa di Risparmio”, con marciapiedi alberati che correvano sull’intero perimetro. In corrispondenza del quadrilatero, tra via Lungomare e il molo Manfredi, di fronte al palazzo di città, delineò un *parterre* rettangolare seguito da una piazza poligonale su cui si innestava un settore trapezoidale compreso tra la spiaggia e la strada per il porto, articolato su un tracciato centrale e spartito in lotti da percorsi trasversali. In essi sistemò l’Istituto tecnico, le Scuole comunali, la Camera di commercio, la Stazione marittima, più avanti, la Dogana e la Pescheria e, sull’estremo della banchina, i magazzini generali, mentre destinò lo spazio ad ovest del Teatro al Banco di Napoli [4].

Le idee, testimoni del vivace dibattito in atto all’epoca nella locale classe professionale, non sortirono alcun esito; i terreni prospicienti alla spiaggia di S. Teresa, rientrati nel dopoguerra nel risanamento del distretto demaniale limitrofo al porto - dove negli anni cinquanta del Novecento fu costruito l’hotel Jolly - sono stati occupati ai nostri giorni dal contestatissimo complesso del “*Crescent*”.

Invece, il piano Colamomico fu adottato e messo in pratica, come denota l’aderenza della situazione odierna a quella da lui programmata. I lavori durarono alcuni decenni, più volte invalidati da nefasti eventi naturali e correzioni in corso di esecuzione¹⁹. A rilento procedettero pure le opere edilizie e solo in età fascista - dopo molteplici contrasti - fu elevato il municipio sul lotto inizialmente proposto e inaugurato nel 1935. Negli stessi anni vennero eretti gli altri immobili principali, quali il palazzo delle poste, il tribunale sull’area del mercato ortofrutticolo e le scuole [1, 3]. Come aveva predisposto il De Sanctis, l’urbanizzazione del litorale si spinse verso la stazione e vide la piena attuazione nel periodo successivo alla seconda guerra mondiale, con lo spostamento verso est degli opifici che sorgevano sull’arenile a valle del corso Garibaldi. Non solo, ma la zona verde del lungomare



Figura 7 - Vista da ovest del lungomare ad inizio Novecento.

Figure 7 - West view from of the waterfront at the beginning of the XX century.



Figura 8 - Vista da est dell’odierno Lungomare Trieste.

Figure 8 - East view of today’s Promenade Trieste.

¹⁹ Ivi, cat. X, cl XII, “Spiaggia 2”; X, cl. XII, fasc. 231 (1); ASSa, *Amministrazione Provinciale*, b. 496, fasc. 5.

fu allargata, aggiungendovi l'ampio viale sul mare, appoggiandosi alle colmate fatte con i materiali risultanti dagli abbattimenti e dai crolli dovuti ai bombardamenti²⁰.

A testimonianza dell'operazione resta oggi la posizione del binario ferroviario, ormai inutilizzato e smantellato nel tratto d'innesto, che rivela l'originario margine dello spazio su cui correva.

Bibliografia

- [1] Bignardi M. (1982) - *La "nuova città" progetti e realizzazioni urbanistiche nei primi decenni del XX secolo*, in A. Leone - G. Vitolo (a cura di), *Guida alla storia di Salerno*, Laveglia, Salerno, 349-361.
- [2] De Seta C. (1999) - *Napoli*, Laterza, Bari.
- [3] Dodaro V. (1997) - *Salerno durante il Ventennio: gli edifici pubblici, l'edilizia popolare, l'urbanistica*, De Luca, Salerno.
- [4] Giannattasio G. (1995) - *Salerno la città moderna. Piani e progetti dall'Ottocento ai primi decenni del Novecento*, Edizioni 10/17, Salerno.
- [5] Mignone A. (2019) - *Porto di Salerno. Una storia lunga dieci secoli*, D'Amico, Nocera.
- [6] Russo M. (2018) - *Il rilancio ottocentesco delle attività portuali nell'Italia meridionale: il porto di Salerno*, in F. Benincasa (edited by), *Seventh International Symposium: monitoring of Mediterranean Coastal Areas: Problems and Measurement Techniques*, Livorno (Italy) June 19-21, 2018, Firenze University Press, 201-212.

²⁰ ASCS, *Fald. 19 Urbanistica*, "Suoli demaniali", lavori in corso nel 1945.

ARTIFICIAL REEF ALONG THE FRENCH MEDITERRANEAN COASTLINE: TOWARD INNOVATIVE INTEGRATED BIODIVERSITY MANAGEMENT

Jessica Salaün^{1,2,3}, Sylvain Pioch², Jean-Claude Dauvin³

¹ Atlantique Landes Récifs, 1 rue du Pitey 40130 Capbreton, France, jess.salaun18@gmail.com

² University Paul Valéry, Montpellier 3, Laboratory Centre d'Ecologie Fonctionnelle et Evolutive, UMR 5172, 1919 route de Mende 34199 Montpellier Cedex 5, France, sylvain.pioch@univ-montp3.fr

³ Normandie Univ., UNICAEN, Laboratoire Morphodynamique Continentale et Côtière M2C, UMR 6143 M2C, 24 rue des Tilleuls, F-14000 Caen, France, jean-claude.dauvin@unicaen.fr

Abstract – Coastal zones are subjected to cumulative human pressure and it is necessary to protect and manage these productive and sensitive marine ecosystems. Artificial Reefs (AR) are relevant tools to overcome these challenges. AR were originally used for fisheries purposes, however for nearly a decade they have also been used in ecological engineering in order to restore specific habitat functionalities. In the meantime, they are also employed to manage human activities e.g.: eco-mooring, as a substitute for natural reefs for diving activities. The review of the latest projects on the French Mediterranean coast shows that apart from the ecological and management objectives, AR are also social tools that could help to enlarge an integrated approach of an ecosystem-based management. Their assessments will have to take into account the entire social-ecological system by using a systemic approach.

Introduction

Nowadays coastal ecosystems are strategically important in the Mediterranean Sea. As the numbers of marine activities increase, so does the pressure on biodiversity. Therefore, it is vital to protect and manage the coastal environment.

Ecological protections as well as the economic development of coastal areas are complex to balance. The recent French report on marine habitat [9], has shown that more than 80% of French coastal habitat is in bad or very bad ecological states. The huge decrease in biodiversity due to the high level of artificialization and pollution threaten main ecological functionalities, future ecosystem health and human activities.

For fifty years, Artificial Reefs (AR) have been deployed (Figure 1) to respond to the decrease in fish stocks [12]. The main objective of these structures was to sustain artisanal fisheries and to enhance fish stocks [5]. The materials used were mostly decommissioned products like old, concrete pipes [12]. The main stakeholders were angler organizations and local or regional authorities. Since the first submersion in 1968 in Palavas-Les-Flots, 26 areas of AR have been established along the French Mediterranean coast with a common objective to increase fish productions (Figure 1). The biggest AR's project named "operation Prado" was conducted in Marseille's Bay in 2007. It was designed to enhance fisheries production, but it was also the first project which incorporated the used of AR as a tool of ecological restoration of marine habitats. Since 2010, the main goal of AR projects was to experiment

with restoration or the creation of key ecological functions: spawning or nurseries. They are also designed to target commercial fish like sea bass or sea bream.

In this study, we present the latest AR projects for fisheries production, development of coastal activities (recreational, eco-mooring) and ecological restoration to offset the negative human impact along the French Mediterranean coast. They are not only innovative because of their ecological objectives and design, but also as a tool for human coastal activities [10]. This diversification in the use of AR is interesting because it makes it possible to manage human activities in coastal areas with one tool. At the end, the understanding of social-ecological systems could help to manage the coastline and also find solutions to protect the marine environment.

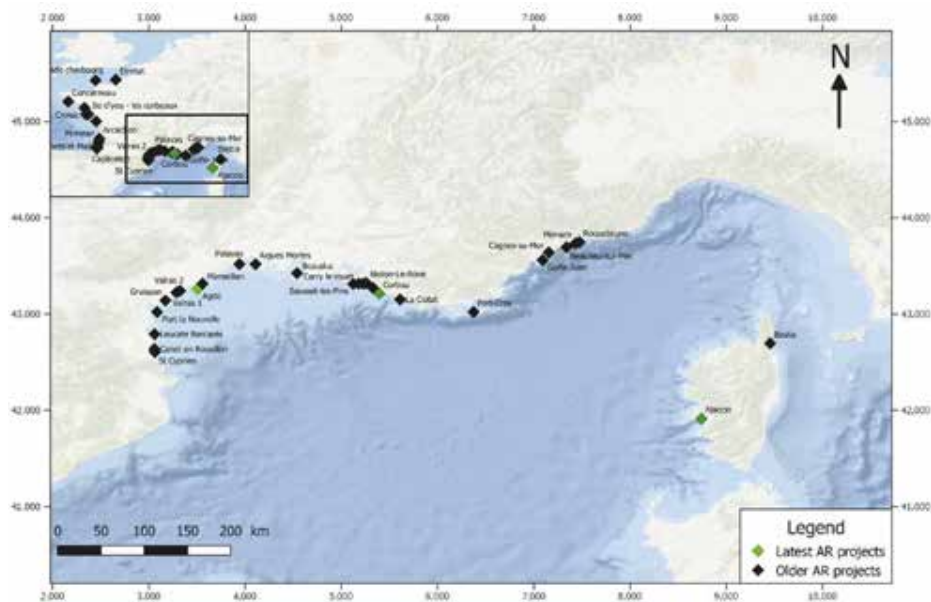

Figure 1 - Maps of the locations of Artificial Reefs along the Mediterranean French coast (Jessica Salaün).

Materials and Methods

Four AR projects have been reviewed according to these new objectives:

- Bio-mimetic AR in the Ajaccio bay in Corsica. Three types of AR were submerged by Corsica’s Environmental Office (CEO) in 2017. They use bio-mimetic technology to recreate the roughness of a natural reef and a chemical reaction to consolidate natural sedimentary particles. They had chosen material such as concrete, metal or broken shells to construct AR. Each AR had different fish targets. Multiple partners had been involved in this project: a scientific community with the Engineering school of Alès and the

University of Montpellier, Geocorail company with their innovative process and also angler organizations with their knowledge of the fisheries. At the end of the experiment and depending on the results, others AR could be submerged to increase the artificial area.

- Rexcor project. On the Cortiou's bay near Marseille in 2018 36 AR were submerged. This project has been conducted in the Marine Protected Area (MPA) of the "Parc National des Calanques" (PNC) and more specifically located at the end of an old sewerage pipe. This project was initiated in 2013, following a call for sustainable ideas and a tender process lead by the PNC, the water agency and the "Pôle mer Méditerranée". The bid was awarded to "Seaboost/Egis" in partnership with "CDC biodiversity" and "Architeuthis" [4]. A total of 36 AR with different designs were submerged. They used bio-mimetic technology to recreate the shape of the natural habitat. Each type of AR was deployed in four sites located at different distances from the end of the pipe. Monitoring is scheduled to evaluate the efficiency of the colonisation on the AR and the effect of this new habitat on the local biodiversity [11].
- Xreef project. In the MPA of the Agathoise coast, 32 artificial reefs were submerged in 2019, in order to delimit 300 m of the coastline (Figure 2). Seaboost Co. and XtreeE Co designed AR with 3D printing technology to provide cavities of different shapes and sizes adapted to the Mediterranean coastal fauna and flora.



Figure 2 - 3D printing AR in Agde (Renaud Dupuy de la Grandrive).

- RECIF LAB project in Agde's harbour submerged micro-reefs for mooring floating piers at the entrance of the port in 2020. This project has been conducted by the city of Agde with the cooperation of Seaboost Company. They had obtained a Future Investment Program (PIA) subvention from the Environment and Energy Management Agency (ADEME) that encourages the development of new tools and services with marine

ecological engineering [1]. Recif lab project in Agde also plans to submerge an artificial landscape structure around natural Brescou reef. It will be built by means of 3D concrete printing. The monitoring will be led by a professional team of marine biologist divers of the MPA.

Results

In the future Mediterranean coasts will have to face increased marine activities and more coastal facilities which will have an impact on marine ecosystems [10]. The environment and biodiversity suffer from the effect of human activities, such as outfall sewerage pipe, anchoring, scuba diving and fishing.

France has developed a framework to avoid, reduce and then compensate for the impact of facilities projects on the ecosystem. Regarding this policy, ARs appear to be effective tools to compensate for the degradation of natural functionalities. An innovative feature of the last French reef projects is the association of ecological objectives with social ones. They respond to the necessity of both protecting and managing coastal areas.

Create new habitat and promote ecological value:

In the bay of Ajaccio, AR was used to provide hard substrate on a sandy sea bottom. They aim to attract crustaceans and commercial fish like lobsters and red sea bream (*Dentex dentex* L., 1758). AR are designed with roughness to facilitate the colonization by benthic fauna, which is the first echelon of the trophic chain. This deployment of AR provides new habitat to specific species in a naturally deprived area.

This program was built in cooperation with local actors like fishermen and free divers. The publicity around the ecological purpose of AR, highlights the environmental actions of the CEO and upgrades the biodiversity of Bay of Ajaccio. The social benefits are twofold: firstly, enhancing scientific knowledge with the results of a three-years-survey and secondly, generating economic profits resulting from the ecological valorisation of the bay.

Helping restoration of natural functionalities and restricted access:

REXCOR was an ecological restoration project that consisted of facilitating the resilience of fish in the area of an old sewerage pipe. The AR had been designed to enhance surface orientations for colonization and create caves as well as natural substrate.

To ensure ecological results, the PNC have forbidden all activities in the area and only researchers have access to the AR for monitoring purposes. Protection of marine ecosystem in providing new substrate also entails limited access of natural substrate. A team of marine patrol officers informs visitors of the policy to ensure that everyone respect the rules. The PNC also raises awareness among divers of good ecological gestures by means of implementing a charter.

Protection through the creation of artificial support for human activities:

RECIF LAB in Agde had developed several AR projects coupling social and ecological objectives. The first one was the Xreef project with the replacement of the old

delimiting system of the swimming area with 3D printed AR. This new buoyage system optimised the cost of maintenance by reducing the number of interventions to only once a year [8]. This system also provides new habitat for the marine fauna.

The second project, submerged AR as a support for floating piers. The micro-reefs are eco-designed [10] to offer safe ballasting to the new mooring system in a dedicated area at the entrance of the harbour [2]. The floating piers system is also designed with *cystoseira* transplantation to create new habitat for small fish .

The last project had involved the creation of landscape AR to provide a new area for scuba diving and shift underwater diving activity from coralligenous marine habitat.

Discussion

With the on-going development of MPA, solutions for restoration or regulation of human activities are expected to increase. A financial program to restore ecological functionalities has been set up by European community and France with programs like “water quality” and Natura 2000 regulation [10]. ARs in France and Europe have recently been used more specifically to restore ecosystems and less to develop fisheries. As ARs seem to respond to this new objective of restoration, they are mostly deployed in already protected areas like MPA or Natura 2000 sites.

In light of the projects presented, ARs could be used in different ways; it can provide supplementary substrate and habitat for benthic and more generally marine fauna and it can sustain ecosystem’s functionalities to substitute natural substrates. This tool has been chosen to respond to both environmental and social economic issues. Environmental issues focus not only on ecological restoration, but also on overcoming the challenging effect of climate change. AR are developed for experimental research and used as a field for observing marine life. Social and economic issues consist of implementing effective coastal management. AR coupled with public investments permit to unify actors of a territory around an environmental project. When the main purpose is ecological, ARs are not used without social restrictions. For example, as they are employed for restoration, policy is implemented to regulate access to these areas. On the other hand, when the social ARs are deployed, they also respond to the ecological concerns by protecting the natural surrounding area.

As ARs are deployed in response to ecological and social objectives, social-ecological studies should be established as a relevant research axis. The most recent approach is to couple the modelling of trophic network with social-network modelling. For example, Ecological Network Analysis (ENA) is a well-known method to quantify how species interact and influence their environment [6]. Social-network modelling also reveals key actors of the network and highlights their connection within the ARs network (Figure 3). Multi-factor analysis takes into account both social and ecological results which helps to design effective management strategies and facilitates the comprehension of their functioning [7]. They could also evaluate ARs efficiency with a systemic approach which helps managers to choose the best tools to balance ecological and social expectations.

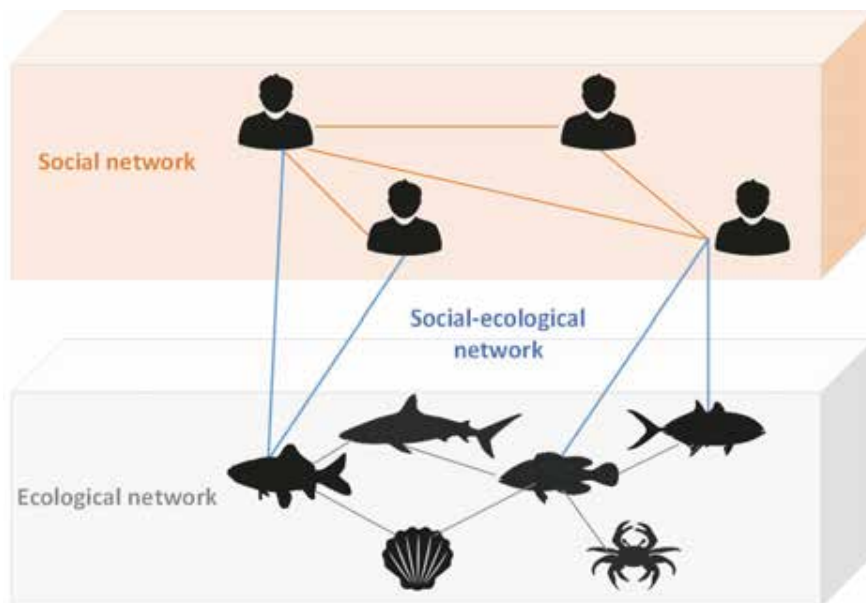

Figure 3 - Example of social-ecological network [3].

Conclusion

ARs do not work as an isolated system. To be useful, they need to be considered as multi-use tools. Primarily used as fishery management tools, their objectives have evolved to include ecological purposes like habitat restoration and social aims such as recreational or eco-mooring tools. The evaluation of the efficiency of new AR objectives also needs to evolve and some adjustments are required. Previously, if assessments had been done, they focused only on some ecological components like commercial fish [13]. Now they will have to take into account the entire social-ecological system, which has been created around AR tools by using a social ecological approach.

Acknowledgements

This research has been co-funded by National Association for Technical Research and Atlantique Landes Récifs Association.

References

- [1] ADEME (2017) – *Recif'lab, Restauration écologique des infrastructures fonctionnelles du littoral agathois et de sa biodiversité*, Fiche projet, projet accompagné par l'ADEME dans le cadre du programme d'investissements d'avenir, pp. 1-2.

- [2] AFB (2017) - *Capitalisation sur les mesures de gestion au sein des Aires Marines Protégées en Méditerranée*, Version finale, pp. 1-50.
- [3] Barnes M.L., Bodin Ö., McClanahan T.R., Kittinger J.N., Hoey A.S., Orou G G., Graham N.A.J. (2019) – *Social-ecological alignment and ecological conditions in coral reefs*, Nat Commun (10), 2039.
- [4] CDC Biodiversite (2018) – *RexCor, dernière immersion des récifs artificiels dans les fonds marins de Cortiou*, retried from <https://www.cdc-biodiversite.fr/news/rexcor-derniere-immersion-des-recifs-artificiels-dans-les-fonds-marins-de-cortiou>.
- [5] Fabi G., Spagnolo A., Bellan-Santini D., Charbonnel E., Çiçek B., Goutayer García J.J., Jensen A.C., Kallianiotis A., Neves dos Santos M. (2011) – *Overview on artificial reefs in Europe*. Brazilian Journal of oceanography, special issue CARAH (59), 155-166.
- [6] Haak D.M., Fath B.D., Forbes V.E., Martin D.R., Pope K.L. (2017) – *Coupling ecological and social network models to assess “transmission” and “contagion” of an aquatic invasive species*, J Environ Manag (190), 243-251.
- [7] Kluger L.C., Scotti M., Vivar I., Wolff M. (2019) – *Specialization of fishers leads to greater impact of external disturbance: Evidence from a social-ecological network modeling exercise for Sechura Bay, northern Peru*, Ocean & Coast Manag (179), 1-15.
- [8] Medpan (2019) – *3D to reclaim biodiversity and sustainably manage the coastline*, retried from <https://medpan.org/3d-to-reclaim-biodiversity-and-sustainably-manage-the-coastline>.
- [9] ONB (2019) – *La nature sous pression, pourquoi la biodiversité disparaît ?*, Bilan 2019 ONB, France.
- [10] Pioch S., De Monbrison D., Simard F. (2019) – *Artificial reefs in France: state of the art and last innovative projects*, Abstract of International Conference on Fisheries Engineering, Nagasaki, Japan, 21st - 24th September, 2019, pp. 1-5.
- [11] PNC (2017) – *Rexcor un projet de restauration écologique de la calanque de Cortiou*, retried from <http://www.calanques-parcnational.fr/actualite/rexcor-un-projet-de-restauration-ecologique-de-la-calanque-de-cortiou>.
- [12] Tessier A., Francour P., Charbonnel E., Dalias N., Bodilis P., Seaman W., Lenfant P. (2015) – *Assessment of French artificial reefs: due to limitations of research, trends may be misleading*, Hydrobiologia (753), 1-29.
- [13] Véron G., Denis J., Gérard A., Thouard E., Thébaud O. (2008) – *Les récifs artificiels, état des connaissances et recommandations*, Ifremer, France.

SPATIAL CONFIGURATIONS AND FLOWS IN THE MORPHOGENETIC PROCESSES OF SETTLEMENTS. A PLANNING EXPERIENCE ON THE TUSCAN COAST

Claudio Saragosa¹, Michela Chiti²

¹University of Florence - Department of Architecture - DiDA

²University of Florence - Department of Architecture - DiDA,

via Pier Antonio Micheli 2 - 50121 Florence (Italy),

phone +39 349 5592324, e-mail: michela.chiti@unifi.it

Abstract – The relationship between man and the environment that produces resources for life is the minimum dimension, around which the comparison with the dynamics of development that generate the settlement arises. This relationship is the conceptual presupposition to contemporary ecology applied to the territory, in which the settlement welcomes the dimension of territory and cities, developed towards the concepts of sustainable design. Their nature as living beings presupposes an intimate, synergistic relationship in which, historically, they co-evolve in symbiosis, changing from time to time, in order to reproduce themselves in balance with local resources. The disturbance of equilibrium would seem to be triggered by the global dynamics developed; the city, the product of cycles of relations between man and earth, based on the use of fossil energy, is transposed into the city, the product of the capitalist production cycle. The introduction of the new functions of living, working, having fun, moving, organizes spaces, denying the primary basic needs related to the well-being of living such as air, climate protection, water and food.

The effects of climate change are manifested before us and increasingly show the fragility of settlement systems no longer able to manage or better resist the phenomena that increasingly affect them.

The process of morphogenesis of cities and territories has sedimented spatial configurations that over time have lost on the one hand the ability to manage a dynamic balance with the metabolism of the reference environment and on the other hand the ability to activate emotions and feelings for the generation of a well-being of living in a place.

Hence the need to rethink the regeneration of settlements, of patterns that are no longer able to manage the modified flows of energy matter.

The contribution, presenting a research experience aimed at planning on the Tuscan coast, has the general objective of outlining and discussing the specificity of the dimensional categories analyzed of the flows of energy in relation to the structures of the territory.

Scientific discussion on the issue has allowed us to experiment with the application of a cross scale survey methodology in territorial context, in order to analyze and recognize what special configurations of the territory are capable of solving the quality of life in the settlement.

Introduction

The relationship between man and the environment, which produces resources for life, is the minimum dimension, around which the comparison with the dynamics of

development that generate settlement is born. This relationship is the conceptual presupposition of contemporary ecology applied to the territory, in which the settlement embraces the dimension of the territory and the cities. Their nature as living beings presupposes an intimate and synergic relationship in which, historically, they co-evolve in symbiosis, changing from time to time, to reproduce themselves in balance with local resources. Man's relationship with the reference environment (producer of resources for life) is therefore the dimension around which settlement is generated, a place where it is possible to rethink a correct management of matter-energy flows [3], and the local environment within which a dynamic balance of human activities can be assessed.

The methodological path of work assumes the territory as a living subject [6]. The reading of the city and the territory as living systems, presupposes the existence of a synergic relationship, with which settlement and reference environment co-evolve in a complex symbiosis, which, changing from time to time, in order to reproduce a dynamic equilibrium over time, produces a strong structural coupling [7]. Each living system is therefore unique and highly differentiated, it is not isolated and therefore develops in synergy with the reference environment, transforming itself structurally and reproducing itself in a co-adaptive way [7].

But the management of natural systems, to be considered as natural capital, is based on two basic principles: the speed at which resources are withdrawn must be equal to the speed at which they are regenerated. If a living organism adapts to environmental conditions with structural changes, which change its behaviour in the future, then human settlement in a cognitive way evolves over time, preserving its networked organisational scheme and identity [8]. Therefore, each territory, each urban bioregion, objectively unique, in its being a place of management of its own matter-energy flows, is the local environment of reference for the "unfolding" of human activities that configure spaces. These configurations are merely the codification of the spatial organisation of the inhabitants in relation to the physiological characteristics of the place, i.e. the rules of the composition of space. If biodiversity makes each territorial ecosystem singular and exceptional, then each spatial configuration is unique, since it is an expression of the organizational dynamics of the energies inside the ecosystem itself and a manifesto of the morpho-typological aspects generated, but also a space of relationship between the work of the inhabitants and their environment of reference. The dynamics of matter-energy-information flows regenerates in relation to the context of belonging, continuously transforming the intimate rules to the natural capital that adapts in space in a cognitive way. The evolution of the ecosystem maintains the recognizability of the invariant identity characteristics, i.e. the relations between the rule and the configuration in a place.

But the disturbance of equilibrium seems to be triggered by developed global dynamics, the city, the product of cycles of relations between man and earth, based on the use of fossil energy, is transposed into the city, the product of the capitalist productive cycle. The introduction of the new functions of living, working, having fun, moving, organizing spaces, deny the basic needs linked to the well-being of living such as air, climate protection, water and food. The disturbance of this balance is also increased by the global dynamics that are emerging both in the organisation of the urban environment and in the climate change that is being generated. The parallel manifestation of these two trends generates a fragility to which we are still responding with inadequate solutions, daughters of the emergency.

The contribution proposed in this essay addresses the above issues through the presentation of the research carried out within the collaboration for the definition of the new

Urban Plan (L.R.T. 65/2014) and aimed at the development of adaptive strategies capable of regenerating new homeostatic balances in a coastal territory over time. In particular, the delicate environment of the groundwater of the lowland, considerably corrupted by the presence of nitrates (due to certain uncontrolled anthropic actions) and chlorides (given by the advancement of the salt wedge caused by the huge withdrawals of water from drinking wells for the now unsustainable summer tourist loads) is the starting point on which we propose a first reflection on the themes of the circularity of the matter-energy flows of the territory and the need to govern the tendential closure of the vital cycles of human settlements [2] [5], overcoming those forms of settlement, manifested in the present, scarcely able to absorb the effects that are manifested synergistically between anthropic dynamics and climate change in progress [4].

Materials and Methods

The area investigated in the research study coincides with the administrative area of the Municipality of Rosignano Marittimo (LI) located in the central part of the Tuscan coast. The municipal territory has a population of 30 672 inhabitants and an extension of 120 square kilometres. The study area, hinged along the coast on the barycentre represented by the settlements of Rosignano Solvay and Castiglioncello, includes a flat part extending southwards by the river Fine for about 10 km with a coastal strip characterized by dune and back dune deposits, and a mainly hilly part extending northwards for about 10 km sloping westwards towards the sea with a mainly rocky coast.

In 2018 the Municipality started the drafting of the urban plan and, given the complexity of the commitment required and the strategic nature of the objective to be achieved, required the collaboration of the Department of Architecture of the University of Florence¹. The research aimed at analysing the settlement load incident on the territory as a topic of discussion in relation to the environmental criticalities highlighted by two studies carried out in parallel with reference to the criticality of underground water resources² and ground temperatures³ [1].

The initial phase of the work first investigated the demographic aspects of the area, aiming not only at the quantitative evaluation of the resident population, but also at the evaluation of the qualitative mutation of the age groups, in relationship to the geographical distribution. The demographic data⁴ provided by the Municipality recruited in the research were: overall population; characteristic of the population by age group; foreign population.

¹ Research Coordinator: Prof. Claudio Saragosa. Title: “Lo studio dello Statuto del Territorio del Comune di Rosignano come fondamento della redazione del nuovo Piano Strutturale L.R. 65/2014”. DiDALabs - Laboratory Plans and Projects for the City and the Territory - Research Group: Prof. Claudio Saragosa, Arch. Michela Chiti, Arch. Tiffany Geti, Urb. Maddalena Rossi, Urb. Lorenzo Bartali, Urb. Agata Miccio, Urb. Alessio Tanganelli.

² Title: “Studio idrogeologico preliminare al nuovo Piano strutturale”. Edited by Myricae srl, Geotecnio Studio Associato, Chiarini Associati. Referring to 2019.

³ Title: “Attività di ricerca volta alla definizione del Profilo Climatico Locale e di un Piano per l’adattamento ai cambiamenti climatici con particolare riferimento alla conseguenza dello stesso sugli scenari idraulici del Comune di Rosignano”. Dipartimento di Architettura dell’Università degli Studi di Firenze, coord. Prof. Iacopo Bernetti - Dipartimento di Ingegneria dell’Energia, dei Sistemi, del Territorio e delle Costruzioni dell’Università degli Studi di Pisa, coord. Prof. Stefano Pagliara.

⁴ Data granted by the registry office of the Municipality referring to 31/12/2018.

Each of the previous data was investigated bearing in mind: the aggregated data provided by ISTAT in order to guarantee the demographic dynamics over time, i.e. in order to elaborate an idea on the dynamism of the phenomena and therefore on possible trends; geolocalized anagraphic data through the distribution of georeferenced house numbers on the vectorial cartography of the Region of Tuscany⁵.

The municipality does not differ much from the emerging demographic phenomena in Italy, one of the oldest countries in the world. If in the second half of the '60s in our country there was the phenomenon of the baby boomer (a showy increase in the birth rate linked to the variations in the economic conditions of the nation closely linked to the phenomenon of industrialisation-urbanisation-economic and cultural growth), in the years closer to today the phenomenon has slowed down drastically until it is reversed.

In fact, today's situation sees a demographic crisis linked to the decrease in births even if, but with problematic implications, there is not a drastic decrease in the population given that we are witnessing a substantial lengthening of life expectancy and a consistent phenomenon of immigration from other nations. In short, with respect to a stability in the quantity of populations there is a substantial qualitative variation in the characteristics of the population as a whole.

Secondarily, the research has analysed the phenomenon of tourism in relation to the spatialization of the receptive structures in the territory. In relation to the last theme, the area of analysis presents itself as a coastal territory and in some periods of the year it becomes an important tourist destination. Analysing the data of the Regional Tourism Observatory⁶, with an average of hotel and non-hotel tourist presences, it has been possible to see how the load of tourists is concentrated in the months from May to September.

The analysis carried out distinguishes the high season period from the low season and considering the average monthly presences based on the 2011-2014 average presences both for hotel and non-hotel structures, we can compare two periods at the antipodes of the calendar: January (3282 average presences) and August (190 015 average presences).

But tourism in Rosignano is not simply assessable taking into account only professional structures, which are obliged to declare the presence of arrivals and presences in their accommodation facilities. In fact, it is necessary to be able to estimate also those tourists who, again for tourist reasons, will come to stay in the Municipality for some periods of time, that is, in short, it is necessary to be able to estimate also those tourists who, not staying in professional structures (hotels, campsites, tourist villages, etc.) wish to spend their holidays in houses or property or for rent.

In this case it is, at least so far, a "ghost" dynamic which does not emerge in official statistics but which must be estimated because, of course, it generates a considerable settlement load and requires a higher amount of services than those which must in any case be reserved to the stable resident population and determines a significant impact on environmental resources.

To this end, the analysis carried out was based on the current size of the building stock, with the identification of the volumes that could potentially be used as residences and

⁵ The topographical base of origin is the one provided by the Region of Tuscany and updated by the SIT office of the municipality as of 2013. The cartography shows the integration of the topographic database in scale 1:2000 (in the main centres) and in scale 1:10 000 for the rest of the territory.

⁶ Data referring to the year 2014.

therefore take on the role of an indicator of the potential settlement load useful to understand the latent capacity of the territory to accommodate additional inhabitants although non-residents.

From the basic data (database of vector files in shape format), the information extrapolated from: DB anagraphic (useful to know the current number of residents for each house number that has been frozen); CTR DB⁷ (useful to know the sizing of the properties); DB house numbers (useful to associate anagraphic information to buildings); DB ground floor urban land use (field surveys in order to identify buildings with a ground floor that is not used as a residence); the parameters of DM 1444/68 to estimate the minimum living volume required by law for an individual.

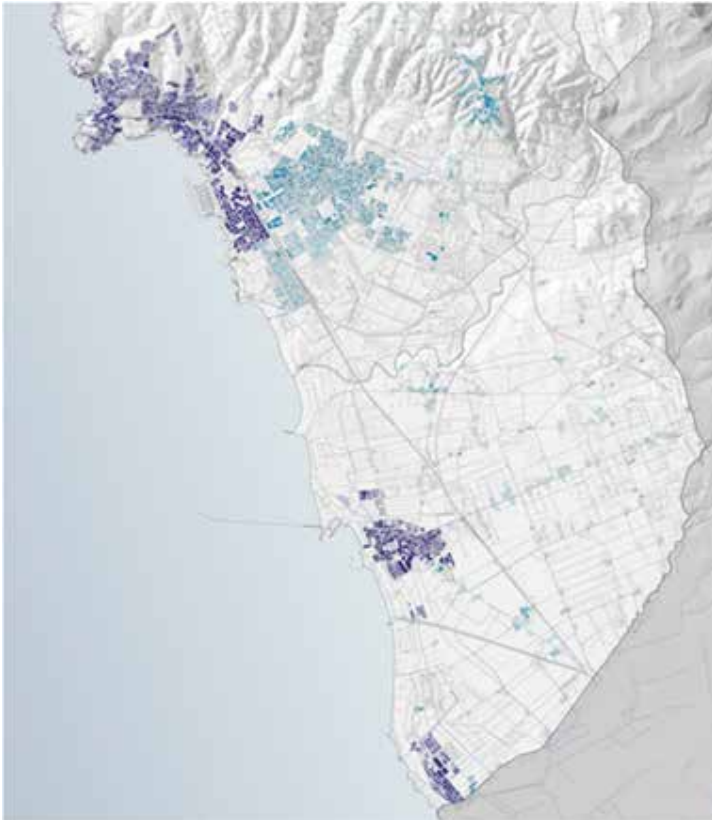

Figure 1 - Distribution of the density of the potential settlement load.

⁷<http://www502.regione.toscana.it/geoscopio/cartoteca.html?cmdUrlComp=N4YwXA2qYOQC4HsQGEAWBTEBrGAaAhmMALYIAm6YARAK4B2IG2A8nBgE4DOVu6dc7AJ6QADLirs4AfrD5JCQJnwA6EAICMirMs6oADj3XjJU%2FMQBGMvp1V8BASyl0aIADbpHAJhHr1PT8bSauzKmlg8AMyBUUpwAZgh0ZAjKqPaurtwAurh6CAiukFOASgAqyACCpcwIAKIVPMUI5OCyAEIAkiXtyDUAcgDKAKqV7Q2lyCVFYyX9AGLMvQAizFSZAL5r60AAA&x=664355.56&y=4802362.75&scale=1055832.2731144577>

The interpolation of the data made it possible to calculate for each building both the potential volumes useful for living and the equivalent potential inhabitants and this result was transferred to the geometries of the relative lots for a better representation of the phenomenon. The data returned is relative only to an empirical estimate of the potential load of inhabitants of each building, and it is released in a static status that does not make appreciate the oscillations that occur during the year.

To evaluate the phenomenon in a dynamic way, therefore, it is necessary to insert the time variable (evaluate the phenomenon of the population present with a monthly scan).

For a better spatialization of the result and to be able to better distinguish the estimates of the potential population, a distinction has been made between areas with a high or low tourist vocation. For this purpose it seems reasonable to identify: the coastal area, very rich in professional tourist facilities, bars and restaurants, such as the part of the territory where most of the volumes, in summer, will probably be rented to tourists.

These areas are identified in the dark blue cartography; the part of the hinterland that does not have a clear tourist definition, with professional tourist facilities as in the other parts of the territory. In this case it is possible to assume that existing residential buildings not occupied by residents can be used less intensively. These areas are identified in the light blue colour cartography.

The areas coloured in dark blue are those that could potentially be the most affected by tourist phenomena, while in light blue are represented those with less tourist influence.

As part of the process of revising the cognitive framework of the Urban Plan, the Municipality of Rosignano wanted to carry out a detailed hydrogeological study of the portion of the municipal territory occupied by the coastal and alluvial lowlands located south of the main town. This area is home to superficial aquifers, included in the first 20÷30 metres of depth, historically vulnerable in relation to the presence of nitrogen (mainly nitrates) and chlorinated pollutants (NaCl from saline intrusion). The study analysed the hydrogeological component with particular reference to the qualitative and quantitative aspects of the underground water resource constituted by the multilayer lowland aquifer present in the southern part of the municipal territory. This is a vast area of the coastal and alluvial plain, about 40 square kilometres, home to many tourist and agricultural settlements and activities and, above all, almost all of the public aqueduct water withdrawals. Through an extensive measurement and sampling campaign, piezometry, electrical conductivity and chloride and nitrate ion concentrations were determined in selected wells with significant statistical representativeness.

Results and discussion

In relation to the distribution of population density it is possible to note some interesting phenomena. In particular, it is clear that while some urban areas not facing the sea are more densely inhabited, others (such as the hamlet of La Mazzanta or Castiglioncello), which are closer, are sparsely inhabited. This phenomenon is certainly linked to tourism, especially seaside tourism. The coastal areas, even if strongly urbanized, are very little inhabited since the houses are mainly used in the summer period when it is possible to activate the activities related to bathing. A large part of the buildings present can therefore be identified as second homes and therefore used by non-residents only for a few days a year, especially during the summer. The low population density has, in other cases, other

explanations: the morphology of the settlement made up of a layout of a few building volumes in large green areas (model of the garden city); or (perhaps in the historical hillside centres) phenomena of abandonment or underuse of the existing building heritage. In other cases we find a high density due to processes of formation of the settlement that have favoured the residency and the construction of properties as first house on morphologies that provide building objects of considerable size, such as economic and social housing areas.

Using monthly data on the fluctuation of the population (residential and potential) and creating a series of 12 frames one for each month of the year, where the geometries of

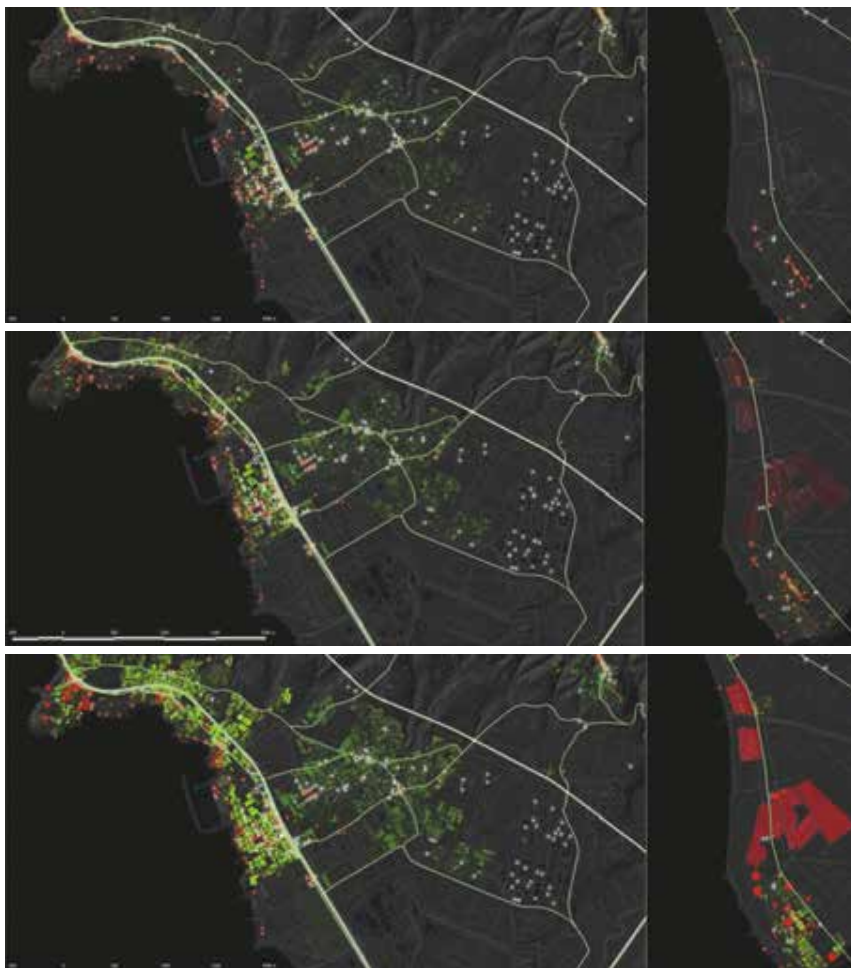

Figure 2 - "Breath of the city" Extract in relation to 3 specific months: January, April, August. It is possible to identify the areas most affected by the increased settlement load. The red dots show the hotel or extra-hotel activities, while the green color show the lots built according to the fluctuation in population density during the course of the months.

the built lots are switched on or off in proportion to a greater or lesser presence of potential inhabitants, it is possible to have a dynamic sequence of how presences, or rather the settlement load, change within the municipal territory during the year.

By defining in this way an equivalence between the potential of each building in relation to the order of magnitude of daily presences for each month, the potential monthly inhabitants that each building could host have been identified.

The graph below shows an estimate of the population that can potentially be hosted during the year. This estimate is obtained by interpolating the potential settlement load redistributed over the various months with the trend of tourist flows in professionalised structures (thus assuming that the tourist flows measured for professionalised structures are similar to those that can also occur for structures used for non-professionalised tourism, second homes). From the graph it emerges that the reception potential in non-professionalised structures (second homes) appears to be considerably higher than the reception, measured, that we have in professional structures (hotels, campsites, tourist villages, etc.) numbers which, although they are estimates, can bring out what the characteristics of the tourism phenomenon in the Municipality of Rosignano Marittimo are.

This estimate of the presence of tourists, which is added to the residents' estimate, allows us to reflect also on the phenomena related to the metabolic balance that must be sought for the urban systems under study.

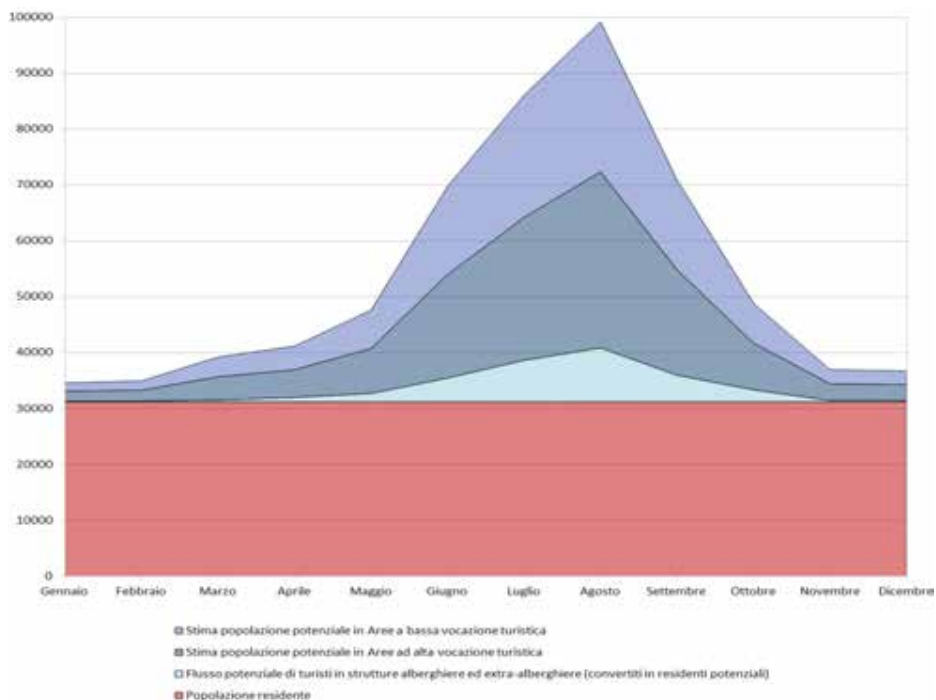

Figure 3 - Estimation of population fluctuation during the year.

From the cartographic comparisons it emerges that in different parts of the municipality we have urban pattern that have led to: low land index; low if not zero settlement of residents; high quantity of volumes normally used to accommodate presences in the summer season. This phenomenon must make us reflect on a system of services and urban planning standards differentiated for the individual parts of the urban fabric (characterized or not characterized by buildings used by residents) and above all on an urban metabolism (water, wastewater, waste, energy, etc.) differentiated over time: subjected to less stress in the autumn-winter-spring period compared to the summer period.

Due to the increase in the summer settlement load according to the methodology presented, it has been possible to understand that the human activities responsible for lowering the soft water table beyond pumping are the reduction of infiltration by soil sealing. Therefore, the lowering of the water table due to higher water withdrawal than the recharge and recall of salt water, could be further aggravated by natural factors such as the decrease in rainfall and sea level rise and at the same time the advance of sea water with intrusion of wedges and salt tongues. In addition, it was possible to observe that a large part of the coastal lowland aquifer was heavily polluted by nitrates with worsening characteristics and in any case with concentrations almost everywhere above the danger threshold. The methodology applied has made it possible to find that nitrates arrive in groundwater by leaching from the soil of excess nitrogen coming mainly from the treatment of agricultural land with chemical and organic fertilizers but also, in a concentrated way, from unpurified civil discharges and from livestock farms.

Conclusion

The proposed method made it possible to geolocalise the data on population distribution in relation to the settlement structure of the territory under examination. This approach has made it possible to highlight and understand the dynamics of real and "ghost" tourist flows, as well as to analyse these phenomena in relation to the effects of climate change and critical issues on water resources. As a matter of fact, the volumetric balance shows a deficit in the annual water balance of the aquifer such as to draw locally within the aquifer 0.68 million m³/year of sea water and almost all the outputs are equally divided between pumping and drainage of the aquifer carried out by hydraulic reclamation works, with a slightly higher incidence of the latter. At the same time, the distribution of nitrate concentration in the surface water table shows an important worsening of the hydrochemical quality in the central part of the plain (Vada hinterland), with values today higher than the legal threshold (50 mg/l) in a wide area that goes from the coastline to the municipal border, where there are few isolated areas with concentrations below the attention threshold.

The results have shown that the maps produced can provide useful information for spatial planning and therefore contribute to the definition of long-term political and structural strategies and thus to the fundamental decision-making process in an urban planning process.

But if the current settlement model has proved to be fallacious, how is it possible to proceed with the identification of design solutions capable of mitigating critical issues or adapting the model to change? The work represents a first contribution on which to develop a methodology for evaluating those forms of settlement, those spatial configurations capable not only of managing the dynamic homeostatic balance in a renewed structural coupling with

the reference environment, but also of stimulating emotions for those who will perceive such spaces. Future developments in research therefore aim at analysing spatial configurations in order to evaluate their degree of adaptation and therefore their survival, maintaining their identity according to that continuous process of selection (attempts, comparison, elimination of errors) in which the proposed configuration compared with a selective environment in which it unfolds is continuously improved both from the point of view of the capacity to manage the ecological flow and from the point of view of perceptive rightness.

References

- [1] Barbierato E., Bernetti I., Capecchi I., Saragosa C. (2020) – *Integrating remote sensing and street view images to quantify urban forest ecosystem services*. Remote sensing, vol. 12, 329-351.
- [2] Barton H., Grant M., Guise R., (2010) – *Shaping neighbourhoods for local health and global sustainability*, Routledge, London_ New York.
- [3] Capra F. (2005) - *La rete della vita*, BUR, Milano.
- [4] IPCC (2014) – *Climate change 2014: synthesis report*. In: Core Writing Team, Pachauri RK, Meyer LA (eds)
- [5] Lyle J.T. (1994) – *Regenerative Design for Sustainable Development*, John Wiley & Sons, Hoboken.
- [6] Magnaghi A. (2010) – *Il progetto locale. Verso la coscienza di luogo*, Bollati Boringhieri, Torino.
- [7] Maturana H.R., Varela F.J. (2004) - *Autopoiesi e cognizione. La realizzazione del vivente*, Marsilio, Venezia.
- [8] Saragosa C. (2005) – *L'insediamento umano. Ecologia e sostenibilità*, Donzelli, Roma.

VIEW MANAGEMENT IN CITY-PORT LANDSCAPES. LIVORNO APPLICATIVE EXPERIENCE

Matteo Scamporrino*

*Università degli Studi di Firenze, Via della Mattonaia 14, 50121 Florence (Italy)

phone +39 339 2218196, e-mail: matteo.scamporrino@unifi.it

Abstract – The paper is an extreme synthesis of a multi-year research path (2013-2017) carried out by Didalab in Regional Design on behalf of the Livorno Port Authority. This research, although born and developed within a specific context, the port one, is part of a more general debate concerning the planning, design and evaluation of urban transformations at a visual and scenic level in complex and stratified territories with historical permanence. The protection and enhancement of the latter is important both on a cultural/identitarian level and on a recognition of the local urban landscape and image of the city.

The ultimate aim of this contribution is represented by the results of the experiments on the tools for measuring the visual and scenic impact, known at disciplinary level as View Management. With this method, widely used in northern Europe, we want to overcome the current rigid "zoning of the heights" which proved inadequate to manage most of the transformations in the Italian port-cities.

The View Management method and tools have been "hybridized" with those consolidated by Italian landscape planning, reaching a quali-quantitative approach. In fact, the research ranges from the use of quantitative ICT tools, such as GIS-3D and Geodesign modeling, at the base of the Northern European View Management plans, to the qualitative tools of Italian regional and provincial landscape planning / design.

Of the visual impact measuring instruments used in the research, only those more markedly quantitative related to Viewsheed Analysis and Line of Sight Analysis are presented for synthesis. Their reproducibility is to be considered almost absolute, in fact also in other places and other contexts the analyses can also be carried out with the same method and the same technical specifications.

The landscape integration reduced to a problem of heights: The paradigmatic case of Livorno

The case of Livorno is paradigmatic and very useful for understanding how important it is to introduce the View Management tool also in Italy.

The works envisaged by the Livorno Port Master Plan approved in 2015 are very substantial both as regards the construction and as regards the docks and spaces for large ships. The new layout of the port is fundamental for socio-economic development and is necessary to allow a global competitiveness of the logistic and production node. At the same time the Port of Livorno, like many other Italian and Mediterranean ports, is "embedded" in the city. There is no clear separation between the port and the city, just as there is no possibility that one will renounce the other. The contact area of the port with the City is mostly in very fragile places and important from an environmental, historical, social and economic point of

view. The transformation of the Port must therefore in no way justify a break in the link between the port and the city and must take into account the landscape and the "genius loci". The main problem is therefore represented by the "close coexistence", and often conflictual, between the operating port and the historic city, between the need to transform and that of protecting.

How can Port and Urban Planning manage to control transformations, both visually and in terms of landscape, while safeguarding the operation of the Port and the historical and cultural heritage?

The most common answer, at least in Italy, to this question is given by limiting the heights of the artefacts by area, the so-called "Zoning of the heights". The case of the Port of Livorno is paradigmatic. In 2013 the Port authority, in a table with the Municipality and the province of Livorno, the Tuscany Region and the Superintendence for Cultural Heritage, limited the heights of the buildings (except for technical systems and structures strictly functional to port activities) inside of the port area according to four degrees: 0 meters, absolute prohibition to build within a buffer of 300 meters around the tower of the Marzocco of 1500; 20 meters, in the area of greatest port-city interaction where the new ferry / cruise terminal will be built and on the more external works; 35 meters, in the construction site area adjacent to the oldest port, the Medici port; 40 meters, in the most operational north area.

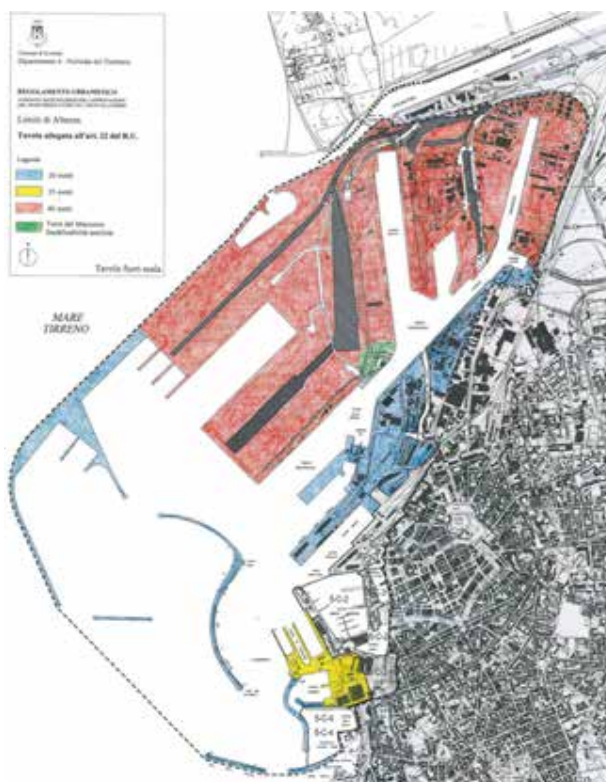

Figure 1 - Zoning map of the heights contained in the anticipatory variant of 2013 to the PRP.

These limitations, if viewed with the "eyes" of urban and territorial planning, may seem adequate if not superabundant. In fact, the Zoning of the heights, widely used in Italian urban plans, rarely exceeds 40 m and often remains below 20 m. But these limitations seen with the "eyes" of the Port prove to be much less adequate. As an example: 30 m is the average height of a ferry or oil tanker, 40 m of a ro-pax ship such as those of the "motorways of the sea" or container ships, over 50 m for cruise ships and container ships of last generation. Furthermore, the aforementioned ships are also slightly less wide and at least eight times longer respectively.

It is therefore easy to understand how the artefacts, facilities and spaces called to welcome them must have an adequate dimensional consistency. The structures and port spaces therefore, by their nature, will be of a higher scale than those of urban or territorial landscapes. The height of buildings and artefacts must have a direct relationship not only with the places frequented by boats but also with the latter which, although by their nature "non-fixed", represent the real architectural and compositional reference. Zoning does not allow you to modulate the heights, nor even to organically compose the full and empty spaces necessary to safeguard the overall landscape as well as the skyline.

In addition, buildings and port structures, by virtue of their considerable consistency, are powerful landmarks, in designing position and height they influence when even miles of distance, and again, the zoning of heights does not allow in any way to control visual and landscape impacts of large area.

The thesis supported by the research is therefore that of a paradigm shift passing from height control (zoning) to the management of the visual and scenic impact (View Management).

Disciplinary references: The landscape and its perceptive scenic components

The European Landscape Convention (CEP) defines the landscape as "an area, as it is perceived by populations, which character is the result of the action and interaction between natural and / or human factors and their interrelationships." (Council of Europe, 2000). Thus, the CEP clearly emphasizes the sensory relationship between the observer and the landscape. The main problem that arises is: how do we know and understand the landscape through perception?

Although "perceived by populations" refers to a holistic experience with all the senses, visual aspects and the sense of sight are often the main vehicle of perception. This clearly has to do with the "range" of our senses. Already Granö (1929) made the distinction between "Nachtsicht" and "Fernsicht". The Nachtsicht, or proximity, is the environment in which we can experiment with all our senses, the Fernsicht, or landscape, is the part of our environment we perceive mainly through experience related to vision.

"The landscape concerns a certain part of the territory, as perceived by people, whose character derives from the natural and / or human activity and their interrelationships" (E.L.C. art. 1, c. A).

The European Landscape Convention refers to the perception that we can define "social", that is shared by a community, something quite different than that of their own individual subjectivity. In fact, there are values that people, or mere observers, associate with the landscape (among them the aesthetic value is the most relevant), these be investigated mainly through direct inquiries on the population. There are landscapes and elements of this

that play an identity ascertained value, documented by iconographic representations, literature and social recognition.

The identification character of rural and urban environments is built on visual perception, which is a key factor in the behavior and preference, and therefore important for the protection of the landscape, monitoring, planning and management and design. We could say that the visual component is the infrastructure, the network, which travels up the landscape in all its complexity, even holistic, recognized by the European Landscape Convention. In other words what is not visible is not even perceptible, appreciable and recognizable by the community and therefore has a landscape value less almost to zero. Obviously, the visual component is not isolatable from the cultural, or environmental, that the supports and substantiates it. Certainly, the only visibility is no guarantee of landscape, in fact although not sufficient is still a necessary and indispensable.

Legislative references: strategic port planning aligns with the regional landscape plan

The introduction of these principles within the Italian port planners chain may seem to be a constraint, as Law 84/94 "Reorganization of port legislation" clearly defines the perimeter of competence of the Port Master Plan and the landscape, together with the visual management, is not mentioned. But in recent years, the management of port-city interaction and co-planning between territorial and port bodies is also gaining importance in the port area. This thanks first to the more innovative Port Regulatory Plans, including for example that of Livorno or Naples, and recently with two regulatory updates (Legislative Decree 169/2016; Legislative Decree 232/2017) which have officially introduced the theme of joint planning of port-city "interaction areas" in the framework of a new governance. The view management therefore becomes a theme fully in line with the Italian port planning chain.

But it is at a regional level where the need to manage in visual control assumes a key role. In detail, the PIT-PPR (Territorial Guidance Plan with the value of the Landscape Plan) of the Tuscany Region in the area files (Schede d'Ambito). In particular, two directives suggest the safeguarding of assets through visual management:

- 1.7 - requalify the large production and logistic platforms from a landscape point of view (Livorno interport; Navicelli canal; Pontedera industrial area), ensure the compatibility of the new interventions and promote projects for the recovery and reuse of industrial structures abandoned;
- 2.5 - safeguard the recognizability, the historical and visual integrity of Livorno, enhance the historically consolidated relationships between the city and the sea, through the redevelopment of the entrances, the urban waterfront and the interface areas between the city and the port area- industrial-commercial, as well as relations with the settlement system of the Livorno hills, including by redeveloping the fabrics of the recent settlement dispersion.

These directives are superordinated not only to the Port Master Plan, but above all to the DPSS (Port System Strategic Planning Document) under development. The latter has the function of providing addresses to future PRPs. The DPSS must contain the View Management Framework so as to ensure its introduction within future port and urban plans.

Disciplinary references: The London method and Piedmont instruments

London. Inside the London Plan is the plan for the economic, social and spatial development of the city in the time frame between 2011 and 2031. The London View Management Framework is one of the tools of this plan. It was conceived by mayor Boris Johnson in 2011 and it was approved in 2012. Its goal is to protect the most historically valuable parts of the city, but also to regulate future developments in the nearest area in a rational and rigorous way. Among these valuable buildings, two are central for this plan: Buckingham Palace and Saint Paul Cathedral. The document defines 27 assessment viewpoints that looks to valuable buildings. From these points four type of representation are determined: London Panoramas, Linear Views, River Prospects and Townscape Views. One of the pros of this document is to regulate the procedure to present a project inside one of these protected views. The project planner who wants to present a proposal for one of these areas would have to present an adequate number of Accurate Visual Representations. These are photomanipulations of the proposal inside the protected area, created in the most rigorous progress that can be always replicated. The required detail level will be adequate to the level of development of the project, and each elaboration will be judged by a commission of specialists. From this experience both the structure of the boards and the Linear Views for experimentation were borrowed.

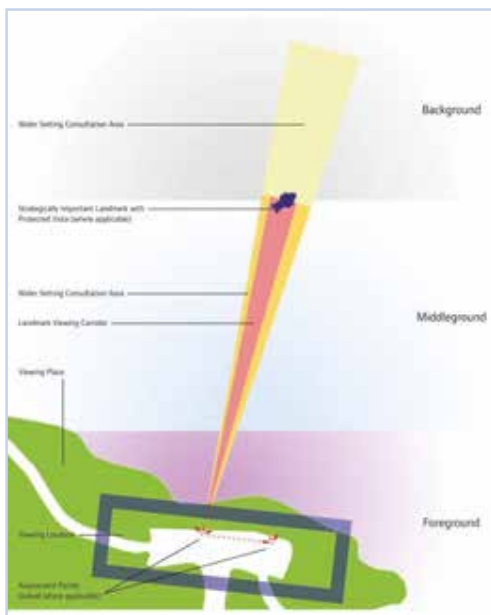

Figure 2 - Illustrative diagram of the linear views of the London View Management.

Piedmont. From the research activity of the DIST (*Dipartimento Interateneo di Scienze del Territorio*) of Turin University and Polytechnic for the regional direction for heritage of Piedmont, the *Linee guida per l'analisi, la tutela e la valorizzazione degli aspetti*

scenico-percettivi del paesaggio were born. Starting from the regional landscaping plan, these directives focus to the local scale and introduce a method to take account to scenic and perspectival aspects to landscape analysis, finding the best view channels, the definition of viewshed for the investigation upon spatial and visual relations. This analysis takes both in consideration areas that are universally acknowledged for their importance and “common” places with situations of particular landscape value (or issues), in the light of the European Landscape Convention of 2000. Moreover, these guidelines try to refine the ideas, tools and methods of scenic analysis, in order to make decisions being built on objective parameters and verifiable procedures. Scenic analysis has to be thought at human scale, because this is our only way to perceive landscape, and this may be difficult to relate with regional-scaled planning. For this reason, these guidelines aim to improve the take in charge of these themes at a local scale. In particular, the methodology of recognition and representation of visual fulcrums has been borrowed through overall panoramas. Another aspect taken up in the experimentation is that related to the GIS analysis IT tools: the Viewshed Analysis.

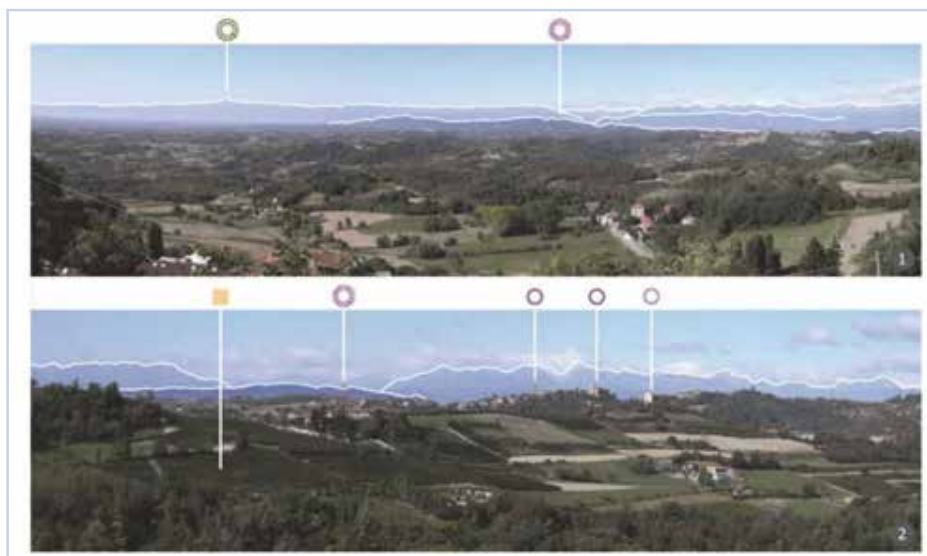

Figure 3 - Representative analysis of the panoramas on a photographic basis, contained in the Landscape Plan of the Piedmont Region.

Measure the visual influence of a landmark or landscape detractor

This type of analysis defines the portion of territory from which a given element or structure is visible. The analysis can concern:

- “positive” elements, landscape-relevant or of historical-identity importance: for example, historical towers, fortifications, monumental trees, etc.... In this case we will talk about positive visual influence that future transformations will have to consider and conserve;

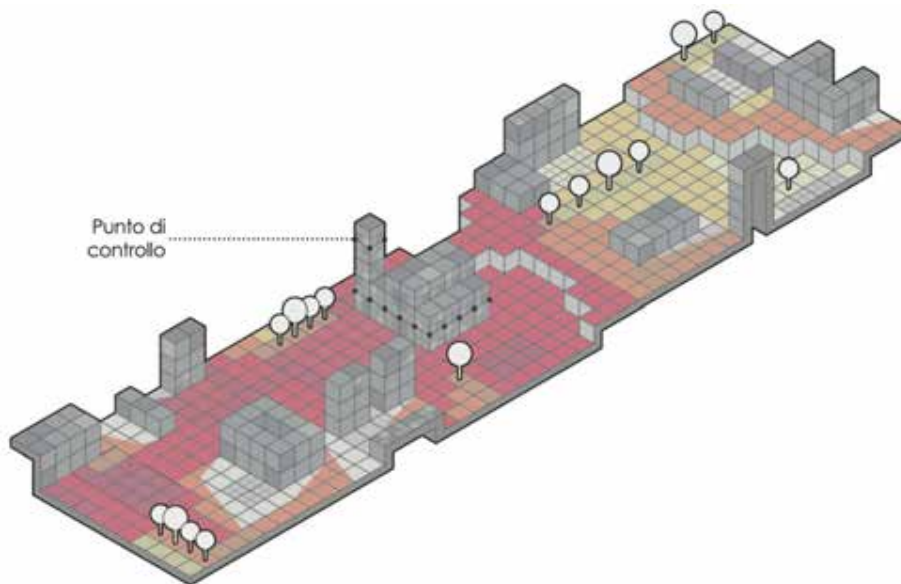

Figure 4 - Exemplary scheme of the basin of influence (Text: “Check point”).

- "negative" elements, impacting landscape and of no importance or identity relevance for the community: for example production structures, industrial buildings, infrastructures, etc ... In this case we will talk about negative visual influence or visual impact, which in the design must be reduced by modifying shape and / or positioning or, in particular for new forecasts, limited with the positioning of shields or structures that prevent intervisibility.

The analysis of visual influence and visual basins have already been used in the PIT-PPR within the regional level report on "visibility and perceptual characteristics" (*Visibilità e caratteri percettivi*). The research then started from this method and elaboration, taking it as a basis and reworking the analysis on an urban scale starting from the valuable historical-identity buildings in the port area.

Viewshed Analysis is used to obtain quantitative information on the actual visibility of an artefact from the surrounding area. The basis of the 3D GIS model is raster and consists of a DSM (Digital Surfaces Model) with cell size appropriately chosen according to the extent of the area under consideration and the quality of the available base data. Several points are identified, a grid, which follow the outline of the artefact from which the simulation is to start. In this the analysis differs from that of the visual basins in which the simulation starts from a single starting point, that of observation. A grid of points joined to the different facades and the roof is created. The program detects from each point the portion of territory from which it is visible. On the basic digital model, visibility at a zero altitude (i.e. coinciding with the surface of the model itself) is not considered but the 1.6 m elevation i.e. the conventional height of the eye of the hypothetical observer. In this way, a clear information is obtained on what is the actual visibility of the artefact directly on the cartography through a classification of the points visible from each single portion of the territory according to an appropriate chromatic scale.



Figure 5 - Example of visual influence of the old fortress of Livorno performed in the GIS environment with the View Sheed Analysis.

Identify the privileged observation places for the Analysis

Privileged Observation Places are public perimeter areas from which it is possible to enjoy the vision of the landscape and the landmarks or identity elements of the landscape.

These places are identified by superimposing the visual influence analysis of the elements of landscape importance (landmark, heritage buildings, etc.) with public areas or in any case for public use (squares, streets, open spaces, terraces, prestigious public buildings etc.). Through this interpolation, it is possible to identify Privileged Observation Places, that is areas with a substantial coincidence between the potential visibility of the landscape and public accessibility to its vision, being, according to the European Landscape Convention, the landscape "a certain part of territory, as perceived by the populations".

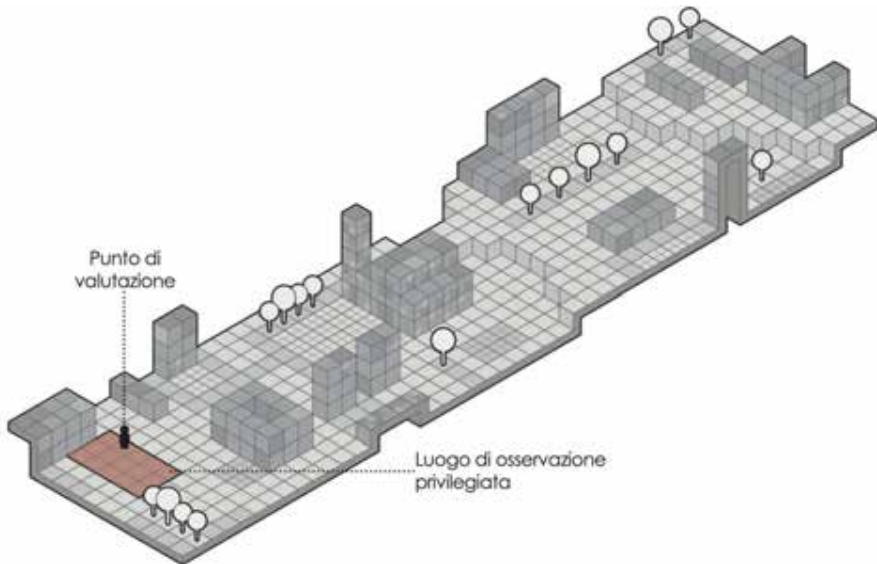

Figure 6 - Exemplary scheme of privileged observation places (Text: "Evaluation point"; "privileged observation places").

Within each of these places, one or more Assessment Points are defined. In each of these the observers are positioned for the analysis of the sets and the analysis of the visual line.

The positioning of these points is designated according to the type of analysis to be carried out following different and ad hoc ratios. In the case of analysis of the sets, the evaluation points will be positioned spaced apart from each other so that they can cover, with the visual cones, the entire landscape around the observation site, trying to position the key landmarks as close as possible to the bisectors of the cone. In the case of the analysis of the visual line, the evaluation points will be positioned in places, taken from the analysis of visual influence, where the landmarks are more visible or in such a way that along the lines the transformation areas are intercepted if known or inferred from urban plans.

The points of origin of the simulations and those of photographic shooting must be taken at the conventional height of the human eye, that is 1.60 m.

Measuring what is visible currently and in the project: viewshed and line of sight analysis

This type of analysis defines the portion of territory or the elements visible from an observation point. This can be achieved through two different analysis tools depending on the specific targets:

- viewshed analysis used to analyze the whole of the territorial or urban surface;
- line of sight analysis to analyze in particular elements and/or structures that develop mainly in one dimension.

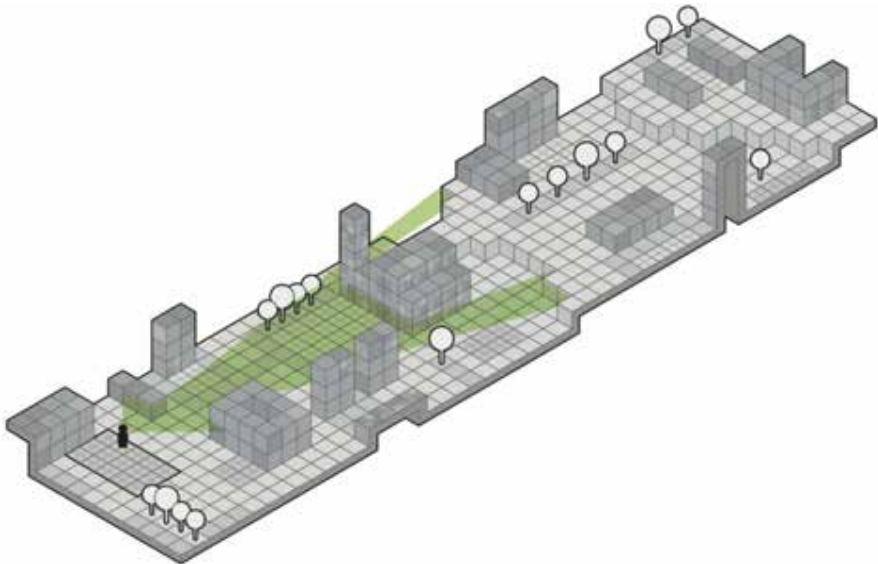

Figure 7 - Exemplary scheme of viewshed analysis tool.

In the first case the viewsheed analysis tool (which can be explained in other words as "visual basin") performs a raster analysis referring to a DSM (Digital Surface Model) where the height of the surfaces is absolute, topical, and does not allow to consider transparency or permeability intermediate lines (holes or openings). In the face of this limitation, however, the analysis allows to consider large portions of territory up to scales greater than 1: 25000 (based on the PIT-PPR intervisibility maps).

It is therefore very useful for data at a territorial level and in contexts of open territory. The accuracy of the analysis is linked to the discretization of the cartographic basis of the digital model in which the cells considered depend on the base source and calculation power of the machine used for processing.

Generally, the DTM (Digital Terrain Model) and DSM supplied by the Tuscany Region (LiDar) have cells ranging from 50 cm x 50 cm up to 2 m x 2 m so as to allow both urban and large area analysis. Among the parameters that can be controlled by the user are the observer's height and his field of view, allowing both targeted analyses, with an amplitude similar to the human visual field, and more general, with an amplitude of 180° or 360°.

In the second case, the line of sight analysis tool performs a terrain-based vector analysis (DTM) and 3D vector elements and structures. For this reason, it manages to be rigorous in the position and morphology of the soil and at the same time to evaluate the elements in their real shape (including openings, holes, cuts etc.). The limitation of this analysis is related to the fact that from the observation point it detects the visual pelvis according to defined points or lines (target). In this case, once the observation point has been chosen, a series of lines are projected starting from it, also in this case with an amplitude and density established by the user.

Having an absolute precision using vector files, it is very useful for detailed analyzes on urban and architectural scale. We therefore speak of elements visible from the observation point rather than portions of territory such as the previous one. This analysis is particularly suitable for identifying obstacles to the view and its impact, geolocating the points of interference along the lines, and distinguishing the visible areas in green and the hidden ones in red. In this way it is possible to locate obstructions in space as well as to know the amplitude in degrees of the obstructed visual field.



Figure 8 - View sheed analysis based on 3D GIS.

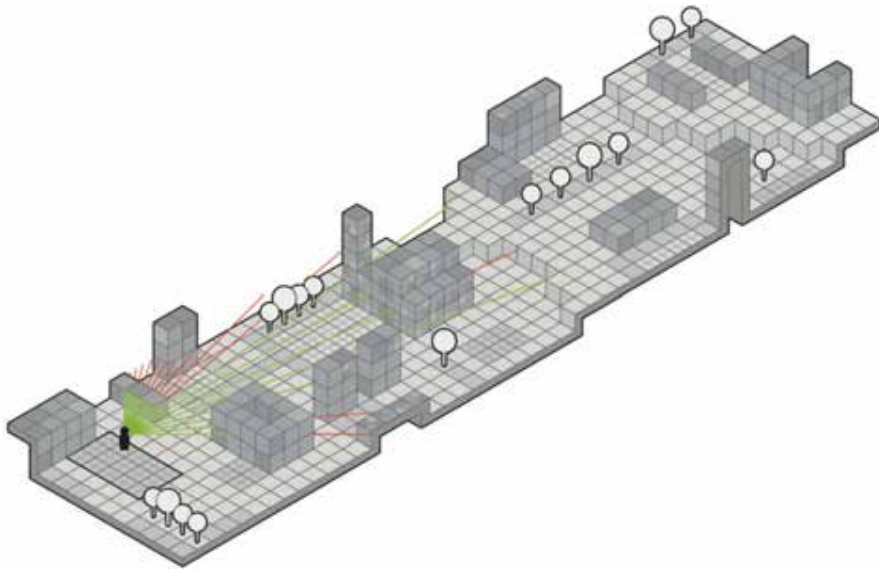

Figure 9 - Exemplary scheme of line of sight analysis tool.

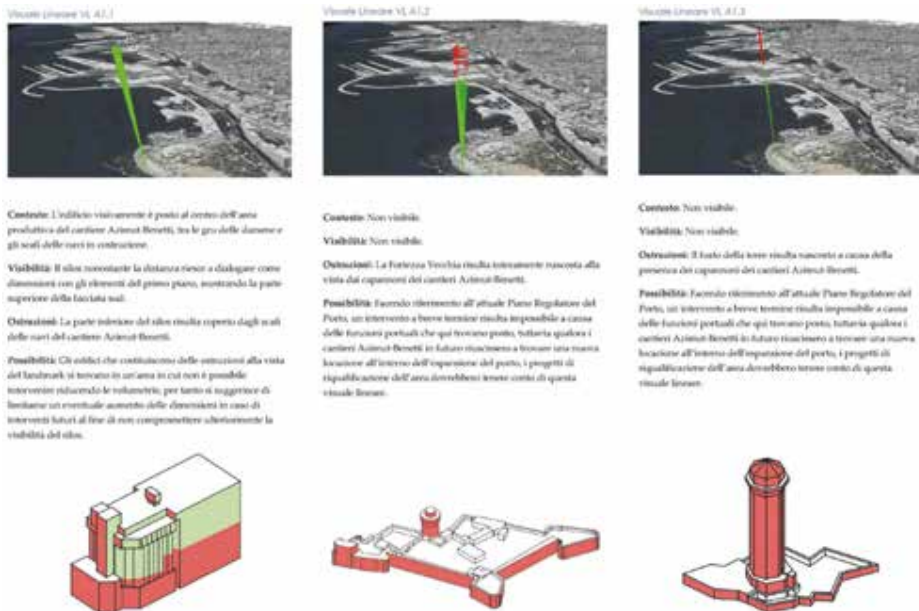

Figure 10 - Extract of the analysis sheets relating to the strategic views of Livorno's Port. At the top, the GIS elaboration related to linear views; a textual analysis of visual characters and visual interference; the real visibility of the protected historical buildings.

The two types of analysis are therefore not alternative but rather complementary based on the type and quantity of basic data, the territorial context in which we find ourselves and the area we intend to analyze.

References

- [1] Various Authors (2009) - *Liverpool Maritime Mercantile City World Heritage Site Supplementary Planning Document*. Liverpool City Council, Liverpool.
- [2] Various Authors (2012) - *London view management framework*. Greater London Authority, London.
- [3] Various Authors (2015) - *Plan the city with the port*. AiVP.
- [4] Various Authors (2015) - *Re-Fact, internation workshop on industrial heritage*.
- [5] AIPCN-PIANC World Association for Waterborne Transport Infrastructure – Italian Section (2002) - *Raccomandazioni tecniche per la progettazione dei porti turistici*
- [6] Bruni F. (2011) - *Elementi per una geografia del paesaggio e del territorio portuale*, in “Portus plus”.
- [7] Cassatella, C. (2014) - *Linee guida per l’analisi, la tutela e la valorizzazione degli aspetti scenico-percettivi del paesaggio*. Dipartimento Interateneo di Scienze, Progetto e Politiche del Territorio (DIST), Politecnico e Università di Torino e Direzione Regionale per i beni culturali e paesaggistici del Piemonte.
- [8] Port Authority of Livorno (2012) - *Piano regolatore portuale del porto di Livorno 2012. Relazione generale*
- [9] Mati (2018) A. - *Un approccio scenografico per la tutela del patrimonio storico-testimoniale del porto di Livorno*, Master’s degree thesis in “Architecture”, Firenze
- [10] Scamporrino M. (2014) - *La costruzione del paesaggio portuale di Livorno*.
- [11] Scamporrino M., Mati A., Montioni L. (2017) - *Photogrammetric survey at the urban scale of Livorno’s ditches*, Proceedings of the workshop AACCP “Reformation, regeneration and revitalization”

INTEGRATED COASTAL ZONE MANAGEMENT OF NATURA 2000 AND CULTURAL HERITAGE SITES IN CALABRIAN COASTAL LANDSCAPE (SOUTHERN ITALY)

Giuseppe Tagarelli¹, Nicola Cantasano¹, Tommaso Caloiero¹, Gaetano Pellicone¹

¹ National Research Council - Institute for Agricultural and Forest Systems in the Mediterranean (CNR-ISAFOM), via Cavour 4/6 - 87036 Rende (CS) (Italy)
phone +39 0984 841460, e-mail: giuseppe.tagarelli@cnr.it

Abstract – This study shows the link connecting natural and cultural goods in the coastal landscape of Calabria (Southern Italy), considering seaboard and human impact risk conditions. In fact, Calabria has 58 Natura 2000 sites located on seaboard areas within a length of 300 meters from coast and 63 cultural heritage sites of which 42.9 % coincides with the Natura 2000 network. As a results of this paper, the increasing coastal erosion and a heavy human impact have been highlighted as the main hazards to which the natural and cultural goods are exposed, thus it's necessary a broader approach for the integration of natural and cultural issues into an active Integrated Coastal Zone Management process.

Introduction

Since the beginning of mankind, coasts have always been engaging to people around the world. The reasons of this attractiveness were based on marine food resources, more favourable climate, coastal lowlands to develop agriculture/urbanisation and, also, best opportunities to facilitate the flow of trade [Pinder and Vallega, 2003]. Millennial presence of human coastal settlements left tangible and intangible memories that, nowadays, represents a fundamental part of cultural heritage of coastal populations. In order to restore, preserve and sustain landscape, natural resources and cultural heritage and to promote a social and economic sustainable development, European Union has promoted the Protocol on Integrated Coastal Zone Management in the Mediterranean (ICZM) signed by Mediterranean countries in 2008, which represented the first legal instrument on this issue [Barale and Özhan, 2010+]. The main objective of ICZM protocol is to improve the sustainable development of coastal zones, ensuring that environment and landscapes could be integrated within the economic, social and cultural development of local people for the benefit of current and future generations. By this way, all the contracting countries are invited to realize sound measures to protect, appreciate and promote the cultural heritage of coastal zones conforming to national and international policy. In Italy, the idea of an overall coastal management became a basic question just from 1982 when the issue was addressed by the Italian law n. 979 which established a general planning for sea and coastal defence and providing for purpose the first marine protected areas, defined as marine and coastal environments with a remarkable richness of fauna and flora species, considerable natural and geo-morphologic features, all showing important cultural, social and economic roles [Satta et al., 2016].

Focusing attention between Italian coastal regions, Calabria is a very interesting case study to understand how both natural and cultural heritage of a seaboard landscape could

be managed within an effective and holistic ICZM planning. Calabria extends for about 250 km from north to south in the middle of the Mediterranean Sea. It shows a coastline of 715.7 km, as the 9.7 % of the whole Italian coastal boundary, extending in the middle of the Mediterranean basin. Due to its geographical position surrounded by the Tyrrhenian and Ionian Sea in the western and eastern sides, respectively, and for its higher altitudinal gradient interesting the Apennine chain, Calabria is one of the richest areas in biodiversity across the EU, [Marziliano et al. 2016]. In fact, the Calabrian sites of Natura 2000 network cover a surface area of about 4.2 % of the whole regional territory and are characterized by the presence of 29 faunal species, 8 of vegetal species and 69 habitats of priority interest included in 92/43 Directive. These last sites supplement the Calabrian regional network of protected areas including 3 national parks, 1 marine protected area, 12 public biogenetic reserves, 3 public oriented reserves, 2 regional natural reserves, 4 protected oasis, 1 regional natural park and 5 marine regional parks. At the same time, from both anthropological and historical point of view, Calabria is an interesting region, for the historical presence of Greek colonization and Roman domination. Moreover, the region passed to the Byzantines, the Lombards and the Normans and, with the rest of southern Italy, to the Hohenstaufen, Angevin, Aragonese, and Bourbon [Placanica, 1999]. Finally, it is interesting to note that the Arbëreshe community, of Albanian origins, settled in this region since the 16th century and is currently located in 25 communes in the provinces of Cosenza, Catanzaro and Crotona [Altimari and Savoia, 1994].

The aim of this study is to pinpoint the risk factors that endanger both natural and cultural heritage located along the Calabrian coastline. At the same time, the authors wish to highlight the actions, within ICZM planning, able to guarantee, simultaneously, protection and use of natural and cultural heritage of Calabrian coastal landscape.

Materials and methods

Special Areas of Conservation (SACs), together with the Special Protection Areas (SPAs), establish a European network of protected natural sites, called Natura 2000. All the protected areas are defined in the European Commission Habitat Directive (92/43/EC) and in the Birds Directive (2009/147/EC) as sites which contribute significantly to the maintenance or to the restoration, at a favourable conservation status, of natural habitats or species, contributing significantly to the maintenance of biological diversity within the biogeographic region to which they belong. In this study, this characterization has been carried out to realize a new kind of landscape pattern able to integrate and improve the environmental, cultural, economic and social issues within the European regulations concerning ICZM process. With this aim, the SACs and the SPAs localized along the Calabrian coastal zone and, especially, the Natura 2000 sites, falling within 300 meters from the high water mark following the “Galasso” Law (1479/89), have been identified. Besides, the cultural sites present along the Calabrian coast, within an area of three hundred meters from coastline have been selected. Finally, the only two islands existing along the regional seaboard have been considered: the islands of Cirella and Dino. This kind of approach belongs to the guidelines of ICZM Protocol and, in particular, to the article 12 which recognizes “special protection to islands, including small islands”. The selected Natura 2000 and cultural heritage sites have been then grouped following these criteria: 1) cultural

heritage sites located within Natura 2000 areas; 2) cultural heritage sites located within a spatial neighbour of 200 meters from the borders of Natura 2000 sites.

In order to take into account the coastal vulnerability, the Coastal Erosion Hazard areas have been considered. This geographical information is drawn by the Extract Plan of Coastal Erosion (PSEC) realized by Calabrian Regional Basin Authority. In the PSEC, the littoral belt, affected by processes of coastline withdrawal, is marked by three different hazard levels from the lowest P1 to the highest P3. This classification results from a multi-temporal analysis of coastline which allowed to characterize the coastal evolution and, especially, the speed of shoreline retreat. A routine in R statistical computing environment [The R Core Team, 2018] has been developed to realize proximity and overlay analysis.

Results

Calabria has 179 SACs and 6 SPAs [MATTM, 2017]. Among these, 55 SACs (30.7 %) and 3 SPAs (50.0 %) have been chosen because they are located totally or partially on seaboard areas within a distance of 300 meters from coastline (Fig. 1).

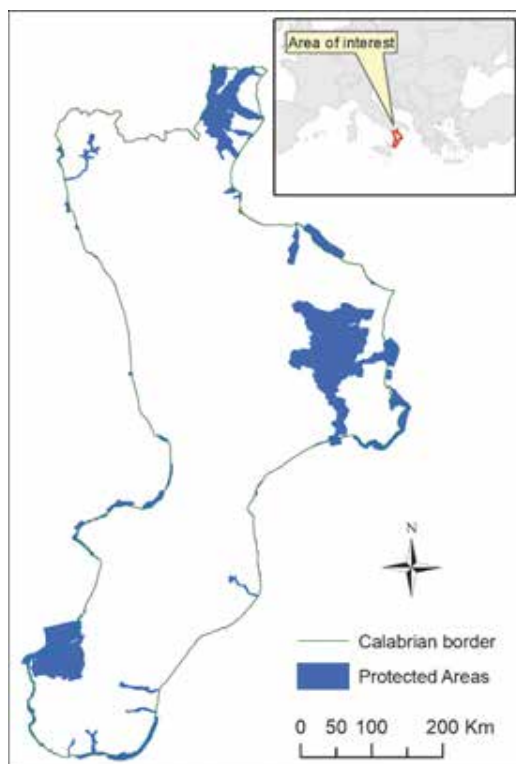

Figure 1 - Localization of the protected coastal areas.

Amongst the 58 Natura 2000 sites, 313 habitats have been considered, including marine (13 %) and terrestrial (87 %) ones. The overlay between Natura 2000 sites and the coastal erosion risk areas evidenced that 85 % of Natura 2000 sites exposes the 50 % of their surface areas to a high risk of coastal erosion (P3).

Sixty-three cultural heritage sites have been identified: eight castles (12.7 %), five churches (8.0 %), thirty-seven coastal towers (58.7 %), eleven archaeological sites (17.4 %), and two Roman fisheries (3.2 %). The overlay with the coastal erosion risk areas evidenced that 76 % of these cultural goods, scattered along the regional coastline, is characterized by a low erosion risk (P1), at a mean distance of 85 m from coastline. Moreover, 3.2 % of the sites, at a mean distance of 3 m from coastline, fall within a medium erosion risk (P2), while, a high erosion risk (P3) characterise 20.6 % of the sites, at a mean distance of 25 m from coastline. In particular, considering the geographical distribution of the sites, 42.9 % of the ones located in the Tyrrhenian side of the region fall within areas with a low erosion risk, 1.6 % within areas with a medium risk erosion and 11.1% within areas with a high risk erosion, with mean distances from coastlines of 90.5 m, 3.0 m and 12 m, respectively. Conversely, along the Ionian side, 33.3 % of the cultural sites are localized in areas characterized by a low risk erosion, 1.6 % fall in areas with a medium risk erosion and 9.5 % in areas with a high risk erosion. These coastal stretches are located at medium distances from coastline of 83 m, 4 m and 35.5 m, respectively (Fig. 2).

Besides, 49.2 % of the cultural sites existing on Calabrian coast are within the core of 58 Natura 2000 areas or within their buffer zones (200 meters). From the overlapping with the coastal erosion risk areas, 35% of the sites showed a risk P1, at a mean distance of 59 m from coastline, 2 % evidenced a risk P2, at a mean distance of 3 m from coastline and, 13 % presented a high risk (P3), at a mean distance of 12 m from coastline.

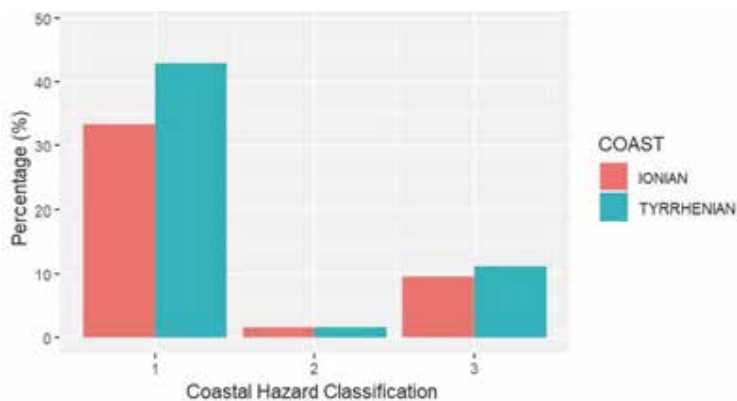

Figure 2 - Percentages of cultural heritage sites within the several classes of coastal hazard.

Discussion

To highlight how cultural heritage sites could be integrated into Natura 2000 ones within the process of an effective Integrated Coastal Zone Management in Calabria, in the

following some interesting case studies along the Calabrian coasts have been discussed. The purpose of such a choice is to highlight that both cultural and natural goods are exposed to the same risk of a partial or total loss.

In Calabria, 64 % of the coastline shows a high risk of retreat. As an example, the coastline between Gizzeria (38° 58' 48" N 16° 12' 24" E) and Belvedere Marittimo (39° 38' 11" N 15° 50' 40" E) in the Tyrrhenian side and between Punta Alice (39°24'04" N 17°09'21" E) and Capo Colonna (39° 01' 31" N, 17° 12' 08" E) in the Ionian seaside are mainly exposed to coastal withdrawal. In particular, the second area is an important coastal area with no artificial barrier. In fact, in this area falls the Marine Protected Area of Capo Rizzuto, one of the thirty-one Italian ones, representing a site of a great environmental marine value and Capo Colonna, whose name derives from the presence of a Doric column, the only remained in place of the ancient Greek temple of Hera (III century b. C.). Thus, this area is both an important cultural heritage site and a Special Area of Conservation that overlap in the same landscape pattern. The cultural heritage is characterized by an important archaeological area extending for about 60 ha which includes a set of Greek and Roman buildings remains going back to a period, extending from the eighth century b. C. to the third century a. C. [Mollo 2018] (Fig. 3).

Some of these remains and especially the buildings located in the eastern side of the archaeological site, are very closed to the sea with an average distance of about 7 m in a straight line from coastline, while part of a “domus” is already collapsed in the sea. From a naturalistic point of view, all the promontory is a Special Area of Conservation (IT 9320101) cause for

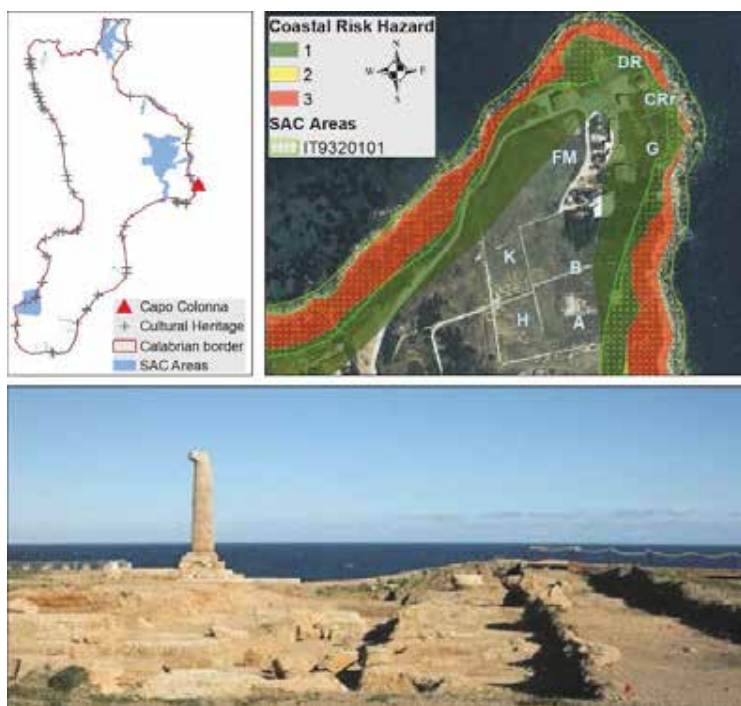

Figure 3 - Geographic position and photo representation of Capo Colonna site.

some coastal habitats: 1210, Annual vegetation of drift lines; 1240, Vegetated sea cliffs of the Mediterranean coasts with endemic *Limonium* spp.; 1310, and Salicornia and other annuals colonizing mud and sand; 1430 Halo-nitrophilous scrubs (Pegano-Salsoletia). Obviously, the highest risk factor in this seaboard area is due to coastal erosion. Really, all the area is marked by three different risk levels from the lowest P1 to the highest P3. Similarly, to the case study of Capo Colonna, other sites are subjected to the same risk of coastal erosion. One of these is, just for instance, Capo Rizzuto (38°54'25" N 17°01'16" E) with a risk level P3. This sensitive area is another perfect case of landscape overlapping between Natura 2000 site and cultural heritage one.

The above areas have highlighted that the main hazard for both the natural and cultural heritage is related to coastal erosion. From an ICZM Protocol point of view, it is necessary a long-term planning to preserve and use both natural and cultural heritage in a global vision perspective. So, a new kind of integrated approach and “ad hoc” actions that should provide for a wider view in coastal management are needed. In particular, as regards coastal erosion, the need for an effective coastal defence system must become the main appointment for the regional authorities through a comprehensive coastal planning in order to avoid single emerging actions. With this aim, in some coastal stretches more damaged by erosional trends, it could be useful to realize operations of beach nourishment never realized along the Calabria coasts in the last decades [MATTM, 2017]. This recovering action must be realized through the selection of suitable sands drawn from seafloor beds close to continental shelf, using the same grain size of the native shore to be nourished. The beach nourishment, together with the demolition of the works of hard engineering, replaced by other operations of soft ones, are the recovering actions suggested by regional policy [Bertollini, 2010]. Particularly, the use of semi-submerged mattress in geo-textile materials filled with sands could guarantee a better protection of the underwater archaeological goods. Really, the use of these tools does not cause drastic measures for their placing on the seabed and are easily placeable and removable also upon archaeological remains without causing any damage [Aminti and Cappuccini, 2012]. Another kind of coastal restoration could be the transplantation of *Posidonia oceanica* (Linnaeus) Delile shoots [Piazzi and Cinelli, 1995; Medina et al., 2001], as well as the use of its seedlings [Pereda-Briones et al. 2018] through restoration projects feasible in some coastal areas more subjected to human pressure or close to dead “matte” of *Posidonia oceanica* meadows. Really, from data analysis and from a careful examination of the frequency distribution of marine habitats, the most widespread one, in Calabrian coastal waters, is *Posidonia* beds that represent a priority habitat of the Habitat Directive (code 1120*). In fact, *Posidonia* meadows is the typical marine ecosystem in the infra-littoral bottom of the Mediterranean Sea on mobile substrates, from the surface to a depth of approximately 35 ÷ 40 meters, being the “climax” stage of a successional process [Ghirardelli, 1981]. Finally, a further defence system against coastal erosion is represented by the protection and the restoration of coastal dunes. Really, from our results, coastal dunes appear residual and very fragmented along the Calabrian coasts, being present in the 39.6 % of Natura 2000 sites. The protection of these sensitive habitats must be realized through nature-based solutions (e.g. braidings, and geo-textile nets) and through the plantation of some autochthonous vegetal species, as for instance *Erucastrum virgatum* C. Presl and/or *Calicotome infesta* (C. Presl) Guss, that could provide important protective mechanisms along the regional coastline.

For many other coastal areas that represent an overlapping between Natura 2000 sites and cultural heritage ones, a great risk factor is the human impact connected to an

incorrect enjoyment of coastal goods. For example, the rock of St. Irene, named also Galea, is about one hundred meters from the Tyrrhenian coastline and it extends in South-West direction of 120 meters in length with a maximum width of 40 meters (38° 43' 31" N, 15° 59' 58" E). It is a typical example of ichthyic plant made by rock excavation (Fig. 4).

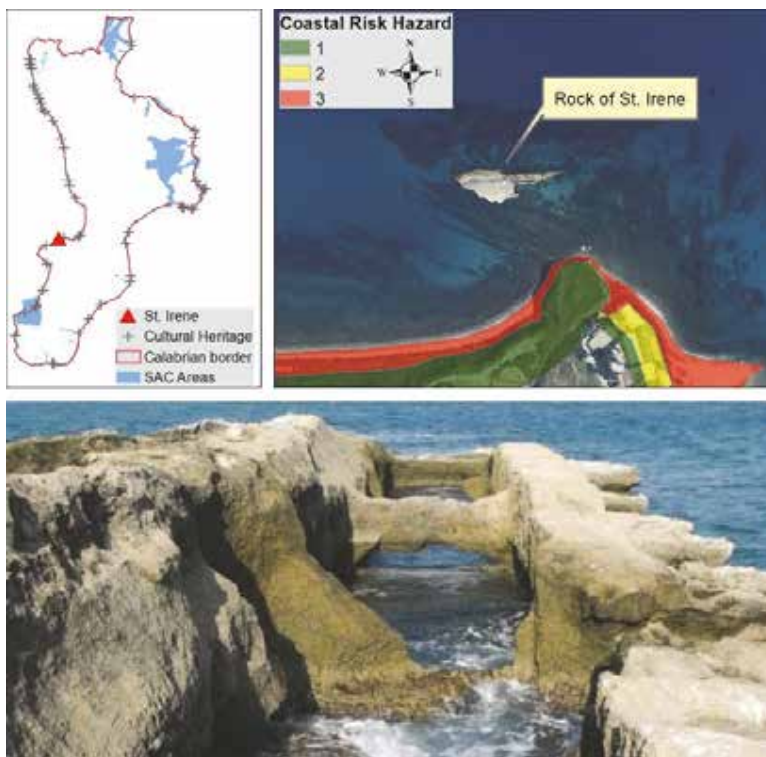

Figure 4 - Geographic position and photo representation of St. Irene site.

The fish pond, by middle dimensions, is made by a complex of four pools showing the remains of flowing grooves and of the moving sluice gates, named “cataractae”, used to close the channels and to prevent the escape of fishes. The pools are perpendicularly crossed by two channels connecting them with the open sea and with an inner harbour, so to assent the water exchange. The harbour was used for the trade of salt fish and the production of “garum”. In fact, on the beach, just in front of the plant, it was located another complex of pools, named “cetariae”, for the fish salting [Iannelli and Mariottini, 2009]. The area, surrounding the rock of St. Irene, including the coastal stretch in its outskirts, is a Special Area of Conservation (IT 9340094) for the presence of following Habitats: 1110 Sandbanks which are slightly covered by sea water all the time; 1170 Reefs; and 1120* Posidonia beds (priority habitat).

Last interesting case is represented by the isle of Cirella, located along the Calabrian Tyrrhenian coast at a distance from shoreline of about 600 meters (Fig. 5).

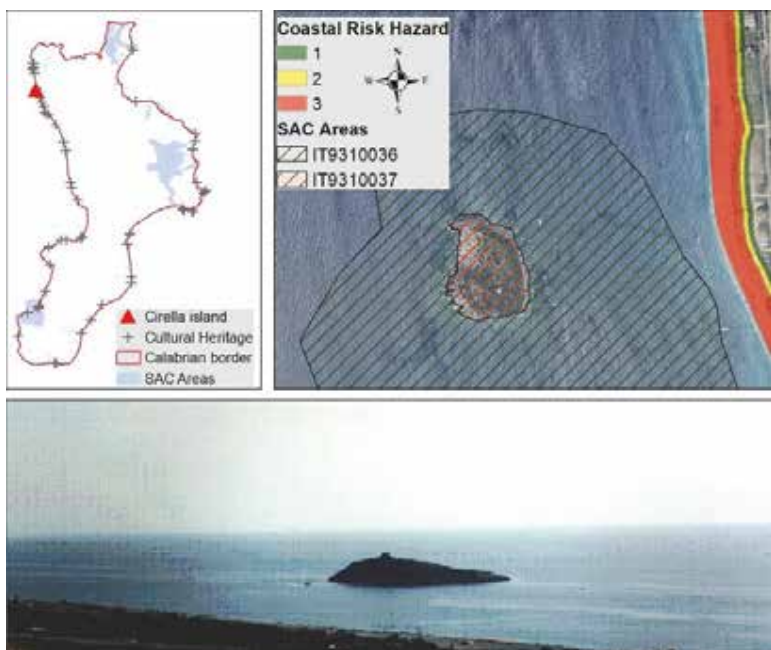

Figure 5 - Geographic position and photo representation of the Cirella island.

For its characteristic geographical position (39° 69' 88" N, 15° 80' 16" E), for the suggestive appearance of a coastal tower and, also, for the presence of a typical Mediterranean vegetation, the island represents one of the most beautiful landscape of the Calabrian coast. All the island is a Special Area of Conservation for the presence of many habitat types: 1240 Vegetated sea cliffs of the Mediterranean coasts with endemic *Limonium* spp.; 5330 Thermo-Mediterranean and pre-desert scrub; 8210 Calcareous rocky slopes with chasmophytic vegetation; 9320 *Olea* and *Ceratonia* forests and, at last, for the priority habitat 6220* Pseudo-steppe with grasses and annuals of the Thero-Brachypodieta. Finally, there is close to the island, in its inland coastal waters, a large meadow of *Posidonia oceanica*, whose broad size allowed to raise this marine site as a Special Area of Conservation (Habitat 1120* priority habitat) contiguous to the terrestrial one located at the top of the island. From a cultural point of view, there is on the top of the island a log-pyramidal tower on a square basis. This tower, nowadays partially in ruins, was built in sixteenth century and it was a part of the military system for coastal defence against the Saracen invasions [Carafa and Calderazzi, 1999]. Besides, in the marine areas between the islet and the coastline it has been discovered some clay materials dated back to third century a. C. [Mollo, 2018]. In this important coastal region, the highest risk is related to the heavy human impact on such sensitive area. The large tourist demand, during the summer months from June to September, represents a real hazard for *Posidonia oceanica* meadows due to mechanical damages for anchor grooving by boating moorings. At the same time, also the Saracen tower and the insular habitats, suffering in summer months by a constant tourist impact, are not protected

by specific measures. Indeed, there is not a correct tourist boarding to inform all the visitors about the natural and cultural heritages still living on the island, just to improve its protection through a more acquainted tourist enjoyment.

As like as Cirella islet, also the island of Dino shows a clear overlapping between natural and cultural goods. All the island, located along the Tyrrhenian coast (39° 50' 18" N, 15° 46' 22" E), is a Special Area of Conservation (IT 9310034). It holds the following habitats: 1240 Vegetated sea cliffs of the Mediterranean coasts with endemic *Limonium* spp.; 5330 Thermo-Mediterranean and pre-desert scrub; 6220 Pseudo-steppe with grasses and annuals of the Thero-Brachypodietea (Priority Habitat); 8210 Calcareous rocky slopes with chasmophytic vegetation; 9320 Olea and Ceratonia forests; 9340 *Quercus ilex* Linnaeus and *Quercus rotundifolia* Lamarck forests. Finally, on the sea bottoms close to the island there are three different areas colonized by *Posidonia oceanica* meadows, whose presence allowed to raise this marine site as Special Area of Conservation (IT 9310035). As well, on the island, at its southern end, it is located a tower by a log-pyramidal section, on a square basis. This tower was built in sixteenth century a. C. and it was characterized by five dropouts and by a typical drawbridge connecting the outside staircase with the feasible floor [Carafa and Calderazzi, 1999].

The above described cases showed that both cultural and natural goods are exposed to the risk of partial or total loss, evidencing that cultural heritage sites and Natura 2000 sites should be integrated into the process of an effective Integrated Coastal Zone Management. The risk of a deterioration of the natural and cultural heritage could be reduced through detailed actions of spreading and awakening of the public opinion, both public and private. In particular, three different levels of public involvement in ICZM policy must be considered. First of all, to actuate a suitable and complete information (passive role) for population and tourists. Then, to realize information systems, pathways and walking routs in the areas more exposed to human impacts, but also to stop the movement and the parking of land vehicles and marine vessels in fragile natural or cultural areas, including beaches and dunes. Finally, to realize a pro-active role in ICZM implementation by the main actors involved in ICZM process, as for instance national, regional and local authorities (active role).

Conclusions

In the coastal landscape, sea and land interact in the same territorial unit integrating coastal ecosystem and its cultural heritage in a whole system, according to the concept of a "landscape continuum". The loss in biodiversity level and the decay of cultural heritage, actually on going, could produce a different landscape feeling and a collective poor memory for the next generations. So, to reverse this negative trend, it could be envisaged a new kind of coastal tourism along the Calabrian coasts able to appreciate the natural and cultural heritages on the seaward and landward sides of the region for an effective Integrated Coastal Zone Management. So, the Calabrian coastal landscape become an ideal pattern where the natural and cultural features of coastal ecosystems could interact for the social and economic growth of local people. Finally, Calabria could provide an innovative landscape model introducing a broader approach for the integration of natural and cultural issues into an active ICZM process.

References

- [1] Altissimi F., Savoia L.M. (1994) - *I Dialetti Italo-Albanesi. Studi Linguistici e Storico-Culturali Sulle Comunità Arbëreshe*, Editore Bulzoni, Roma.
- [2] Aminti P.L., Cappuccini L. (2012) - *Utilizzo Di Contenitori in Materiali Geosintetici Riempiti Di Sabbia per La Protezione Di Strutture Archeologiche Sommerse*, *Geologia Dell'Ambiente* XX, 29 - 31.
- [3] Barale V., Özhan E. (2010) - *Advances in Integrated Coastal Management for the Mediterranean & Black Sea*. *Journal of Coastal Conservation* 14, 249 - 255.
- [4] Carafa R., Calderazzi A. (1999) - *La Calabria Fortificata. Ricognizione e Schedatura Del Territorio*, Mapograf, Vibo Valentia.
- [5] Ghirardelli E. (1981) - *La Vita Nelle Acque*. In: *Biocenosi Delle Praterie Di Posidonia*, Utet, Torino.
- [6] Iannelli M.T., Mariottini S. (2009) - *Rinvenimenti subacquei nel territorio di Hipponion – Vibo Valentia*. In: *Relitti, porti e rotte del Mediterraneo*, Università della Calabria, Rende (CS).
- [7] Bertolini M. (2010) - *La Gestione Integrata Dei Paesaggi Costieri in Italia. Stato Dell'arte Ed Applicazioni Nel Panorama Italiano*. ISPRA, Roma.
- [8] Marziliano P., Lombardi F., Menguzzato G., Scuderi A., Altieri V., Coletta V., Marcianò C. (2016) - *Biodiversity Conservation in Calabria Region (Southern Italy): Perspectives of Management in the Sites of the 'Natura 2000' Network*, *Proceedings of the International Conference on Research for Sustainable Development in Mountain Regions*, Bragança, Portugal, 5–7 October 2016, pp. 30.
- [9] MATTM. (2017) - *SIC, ZSC e ZPS in Italia*, <https://www.minambiente.it/pagina/sic-zsc-e-zps-italia>.
- [10] Medina J.R., Tintoré J., Duarte C.M. (2001) - *Las Praderas de Posidonia Oceanica y La Regeneración de Playas*, *Revista de Obras Publicas* 148, 31-43.
- [11] Mollo F. (2018) - *Guida Archeologica Della Calabria Antica*, Rubettino, Soveria Mannelli (CZ).
- [12] Pereda-Briones L., Infantes E., Orfila A., Tomas F., Terrados J. (2018) - *Dispersal of Seagrass Propagules: Interaction between Hydrodynamics and Substratum Type*, *Marine Ecology Progress Series*, 593, 47-59.
- [13] Piazzini L., Cinelli F. (1995) - *Restoration of the Littoral Sea Bottom by Means of Transplantation of Cuttings and Sprouts*. In: *Posidonia Oceanica, a Contribution to the Preservation of a Major Mediterranean Marine Ecosystem*, Rivista Rivista Marittima publ, Roma.
- [14] Pinder D., Vallega A. (2003) - *Coastal Cultural Heritage and Sustainable Development: Introduction*, *Journal of Cultural Heritage*, 4, 3-4.
- [15] Placanica A. (1999) - *Storia Della Calabria: Dall'antichità Ai Giorni Nostri*, Donzelli Editore, Roma.
- [16] Satta A., Giambastiani M.S., Addis D., Mannino I., Sanguineti I., Ulazzi E. (2016) - *Towards the Implementation of Integrated Coastal Zone Management in the Mediterranean: The CAMP Italy Project*. In: *Coastal Zones: Management, Assessment and Current Challenges*, NOVA science publishers, New York.
- [17] The R Core Team. (2018) - *R: A Language and Environment for Statistical Computing*. R Foundation for Statistical Computing, Vienna, Austria.

LAGOON SCENARIOS FOR THE BASSA FRIULANA PLAIN: A FLOODING ARCHIPELAGO

Adriano Venudo¹, Valentina Rodani², Valentina Devescovi³

¹DIA, Department of Engineering and Architecture University of Trieste (Italy)
phone: +39 3472921588, email: avenudo@units.it

²DIA, Department of Engineering and Architecture – University of Trieste (Italy)
e-mail: valentina.rodani@phd.units.it

³ DIA, Department of Engineering and Architecture – University of Trieste (Italy)
e-mail: valentina@devescovi.it

Abstract – The territory of the Bassa Friulana plain has been the arena of constant adaptation and alteration between lands and waters over the centuries. The matrix of geomorphological features characterized by the alluvial origin of the Tagliamento river artery and by the presence of *risorgive* expound an emblematic case of the landscape of flux. Moreover, the socio-economical conditions incessantly adapted through the assortment of landscapes: forestry (from the ancestral *silva lupanica* to the exploited pine forest), both extensive and intensive farming (from the *agro-centuriatio* to the *manso*, then the great land reclamation and urbanization), energy and tourism (as in the seaside town of Grado or in the fishing Marano Lagunare which pressurize the lagoon). Indeed, par excellence is a landscape of transition and a fragile subject to climate change, albeit an extreme laboratory to cope with its multidimensional impacts. The research aims to investigate the complexity and uncertainty related to the transformation of this territory, through the connection between retro-coastal morphological evidence and embedded resilience. The paper first focuses on the morphological history of a landscape unit, consisting of biological deserts and wrecks of the endangered landscape. Secondly, it analyzes and elaborates hydrological scenarios to explore and discuss potential design strategies. The research hypothesis advances that the hydrological risk represents an intrinsic and retroactive vulnerability of the area that, if recognized, could be adapted and mitigated. The water margin continuity could be recovered, restored and monitored through the development of flooding strategies to respond to possible future fluctuations. In conclusion, the form of the archipelago emerges as a specificity of the landscape unit. More than a metaphor but as a conceptual and programmatic dispositive, the archipelago can inform on the dynamic structure of the Bassa Friulana complex system within an ecological framework.

Introduction. Coast and lagoon territories: Friulian deserts

A drifting landscape of flux – The Bassa Friulana plain is a territory in the north-east of Italy that extends from the easternmost edge of the Po Valley to the karst plateau of the Monfalconese area, within a strip of land between the *risorgive* and the lagoon edge of Marano and Grado, where the distance between the Alpine belt and the Adriatic coast compresses almost to disappear. It is historically and culturally marked by the combination of lands and waters. On the one hand, the former's settlement and development were subordinated to the control of the latter. On the other, the different degrees of resistance between anthropic action

and environmental pre-existences gave shape to such heterogeneity, a compendium of the universe [1], or a mosaic of landscapes. The matrix of geomorphological features characterized by the alluvial origin of the artery of the Tagliamento river and by the presence of springs make this territory an emblematic case of transition landscape. The waters of normal flow sink into the more permeable and gravelly soils like the *magredi* in the high plain; once they resurface from the clayey and sandy soils of the lower plain, giving rise to the phenomenon of *risorgive*. Land depressions and elevations decline several water shapes, from natural springs such as the *olle* (catiniform) and *fontanai* (irregular in shape) to low bogs and wet meadows, swamps and waterways, nearly the lagoon. The *risorgive* belt embodies the watershed between the most refractory dry plain and the humid one. The latter was once a highly differentiated riparian and plain woods, a habitat of meadows, such as the ancient *magna silva* (or *silva lupanica*, localized between the river Isonzo and Livenza, *phaetontea*, from Livenza towards the west, and the *silva diomedea*, from the Isonzo towards the karst) [2], whose permanence has been questioned continuously by the action of man, resulting today in scarce wrecks.

The shape of water: from the agro-centuriatio to the manso – To inhabit this plain, the man had to deal with the absence at least as much as with the multifaceted presence, sometimes generating but sometimes destructive, of the waters. There are two settlement structures that, declined in a great variety of morphologies, have stratified over time: the first, in the plain close to the springs, confirms the matrix of the road and hydraulic infrastructure of the *agro-centuriatio*, forming a network of rural and close-knit villages, where the population was mainly peasant. Instead, the second, found in the lower plain, develops in a more dilated network of villages integrated with the *mansi*. Wetlands guarded vast, empty and cultivated fallows, alternated with grasslands and forests inhabited mostly by shepherds or cattle breeders and with roads branching out in all directions. Both configurations are supported by a vibrant hydrological network which, starting from the river arteries, crucial for commercial exchanges, has fed open-air aqueducts, such as the irrigation ditches, flanked to a greater extent by other forms for the collection of rainwater, such as wells, ponds, cisterns, and tanks. However, none of these solutions has ever been sufficient to solve the problem of conserving water for periods of drought in the most permeable plain just north of the springs, nor to regulate its vast presence to make all the lands in the plains humid and productive. The lowland forest played a vital role in the territory's fluctuating development; it represented the margin between these two forms of settlement, never precise but extremely manipulated by anthropic action. In fact, the forest undergoes the Roman settlement logic, as a precious resource of wood and game, with radical interventions of selective reclamation, deforestation and tillage of the lands. However, it also becomes a refuge from incursions and gradually recovers only with the abandonment of the countryside and the swamp during the Lombard occupation to then reach maximum expansion with the Hungarians' invasions. The subsequent repopulation of the plain through the Slavic colonization is partial to the disadvantage of the forest mantle. This collective heritage will be very slowly incorporated into the villages, partly protected with the regulations of the Serenissima Republic but, since the end of the 19th century, progressively annihilated.

The shape of the city: from the manso to the metropolis – At the beginning of the nineteenth century, the Bassa Friulana landscape was rich of hygrophilous scrub, woods of hard essences, shrubs combined with meadows and wet meadows that, according to historical cartography, extended for about 5000 ha. Nevertheless, thanks to the increase in agricultural activity and the land reorganization of the large agricultural villas, which partially eroded the forest heritage, but above all starting from the significant reclamation works on the plain, it

takes less than a century to halve them. Massive deforestation combined with necessary interventions on several stages of construction of the network of reclamation canals, which govern the *risorgive* waters, those of meteoric origin and the floating ones of the lagoon with the embankments, rationalize the waters by converting the lands into surfaces for production and consumption. After World War II, the surviving forest heritage corresponds to 700 ha [3] fragmented in islands surrounded by extensive agricultural fields and intensive fish farms, only half of which has survived. It is a profound and rapid transformation of the meaning attributed by the population to waters and lands. That persistent element, not traceable in the building constructions but the totality of the settlement structure of a rural metropolis, historically very differentiated, that is the shape of the city [4], almost automatically undergoes the tyranny of the right angle giving rise to a physical and social structure summed up in the word Los Angeles [5]. The result and assiduity of the recent urbanization process, of which man began to be globally aware in the early 1960s but locally only in recent decades, is apocalyptic and configures a permanent emergency condition. Suffice it to say that in the post-lagoon zone, the drainage of wetlands, the depletion of groundwater, and soil loss have reduced natural geomorphology to a minimum. It accelerated the phenomenon of subsidence structuring a substantial hydraulic instability. 12300 ha of land (equal to approximately 18.6 % of the area) are below sea level and the 566 km of the surface hydrographic network is joined by 698 km of canals that require continuous maintenance with defense and safeguard works. In three-quarters of the lands, the intensive and semi-intensive rural landscape dominates (50600 ha, equal to 76.5 % of the area). It consists of extensive crops, only in microscopic part, together with the anthropic areas, which fragment and isolate the 4996 ha of natural environments and wrecks (of which approximately 1900 ha of floodplain and riparian forests, 645 ha of lowland oak forest, 428 ha of stable meadows of anthropogenic origin, 82 ha of wet herbaceous environments, 50 ha of peat bogs low alkaline, 54 ha of small strips of dry grasslands and about 123 ha of fertilized grasslands) [6].

Friulian deserts: biological non-place and wrecks – This landscape of transition has been the stage of constant and mutual adaptation over the centuries. The socio-economical transformations gave shape to the waters through the agro-pastoral development of the territory. However, this relation reached a breaking point since man destroyed the shape of the city through extensive, invasive and rapid urbanization. The aqueduct solved the problem of drought where waters were once collected by the bronze fabric dotted with mills, wells and cisterns. While the network of canals and the land reclamation rationalized terrains, which became productive and attractive, ready for use as well as abuse, where the abundant waters nourished once dynamically humid grasslands and forests. That territory characterized by the presence of springs and the lagoon has been subject to more than a century of invasive anthropic transformations and the evident effects of climate change. These changing and adaptable margins are the most fragile landscape, today in crisis. The exploitation and reclamation of lands and the development of mass tourism, at least as much as the implementation of monocultural and intensive farming, have produced a systemic environmental upheaval, enabling the manufacture of a new landscape: the deserts of Friuli. Comparable to metropolitan non-places [7], these surfaces of biological desertification are landscapes of production, which, in addition to being the cause, amplify the effects of climate change in recent decades, such as the intensification of abundant rainfall, the rise of temperature and sea level, and subsidence. These phenomena represent agents of fragmentation of habitats and of the collective landscapes mosaic plain which risks, and it currently is to a certain degree, the irreversible and unavoidable conversion into an archipelago of wrecks. Indeed, it suggests a

landscape of transition extremely fragile to climate change, but also a radical laboratory to experiment with its multidimensional impacts. The recognition of morphological evidence indicates a history of adaptability and constant landscape combination, so it is possible to hypothesize that the margin between land and waters acted as a dynamic network, both self-regulatory distance and dispositive of differentiation as well. Furthermore, the hydrogeological risk can be investigated as a structural vulnerability of the landscape unit, exploring its resilience potential through the analysis of lagoon-based scenarios. This indicates that starting from the acknowledgment of past, present and projected water margins it is possible to explore strategies of recovery, restoration or transformation of the landscape. Whether as a result of anthropic pressure on the lagoon or its inherent structure, the Bassa Friulana plain is clearly sinking. That is to say, what if the Bassa Friulana plain would be transformed into a floodscape [8]?



Figure 1 - Friulian deserts: biological non-place and wrecks. Photograph of a portion of the "reclamation campaign" near the Marano Lagoon, between Latisana and Lignano Sabbiadoro (Udine).

Materials and Methods. The square and the hexagon

The landscape unit consists of a coastal strip ranging from 2 km to 8 km of the Bassa Friuliana plain, which surrounds Marano and Grado's natural lagoon reserves, extending from the Tagliamento river near Latisana [9] to the Monfalconese karst near Aquileia¹. The case

¹ The landscape unit has been recently investigated in the *Green Plan of the Municipality of Latisana* (Environmental Plan L.10/2013) by the *Integrated design laboratory of city, territory and landscape* (a.y. 2019-20 Master degree in Architecture of the Department of Engineering and Architecture, University of Trieste); Venudo A., Ceschin, E., Del Fabbro Machado, L. (2020) - *laboratorio PAESAGGIO LATISANA*, EUT, Trieste.

study is investigated through quantitative and qualitative data analysis, then processed through a landscape mapping and scenario analyses. Firstly, the data collection reviewed the cartographic materials retrieved from historical and land use sources, with a specific focus on landscape morphology, for instance, the evolution of plain woods, the transformation of historical wetlands due to the great reclamation and the changes related to waterscapes (as waterways and coastlines). Moreover, the consultation of specific literature (as archaeological studies, local history, ethnographic researches) informed the groundwork map, representing the landscape unit state of the art. Successively, the map has been superimposed with the scenario analyses developed by FVG Region in the study and evaluation of the impacts of climate change on coastal areas, then revised with the PAI scenarios which produced comprehensive zoning of the hydrogeological risk for the Marano and Grado lagoon basins [10, 11]. These scenarios consider the components of sea rise and lowering of the soil within a time interval at 2100, corresponding to +54 cm, +94 cm and +134 cm of potential flooding, which in the latter case would imply the doubling of the currently depressed surface. The superimposition of the landscape unit state of the art with the scenario simulations displays a preliminary map (Figure 2), representing the lagoon scenario for the Bassa Friulana plain. Secondly, the mapping process has been informed through morphological analysis. The investigation of landscape matrix and spatial structure (Figure 3), the hydrographic basin (Figure 4), the infrastructural network (Figure 5) highlighted the configuration of a surviving territorial archipelago.

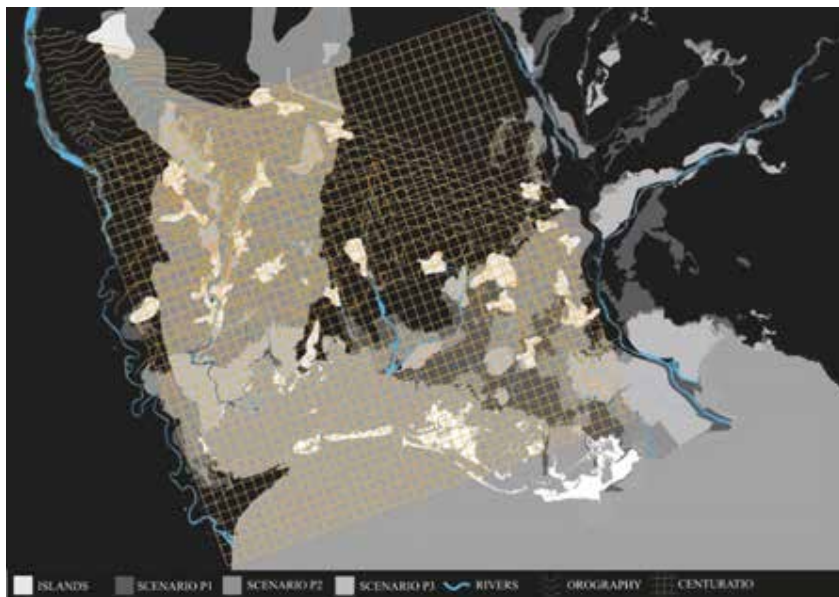

Figure 2 - The spatial matrix of the territory is generated by the grid, which abstracts the ancient Roman *centuriatio*, and by the orographic structure. Given the close relationship between the elements, it follows that the most populated areas are those with the most significant hydrogeological risk.

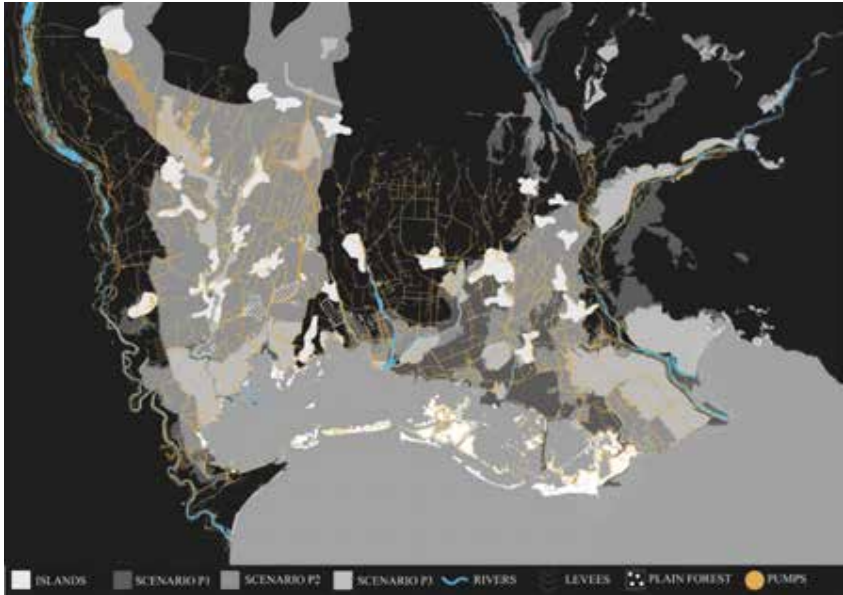

Figure 3 - The hydrographic basin evidences the anthropic pressure on waters control, as in the isotropic and vast network of embankments.

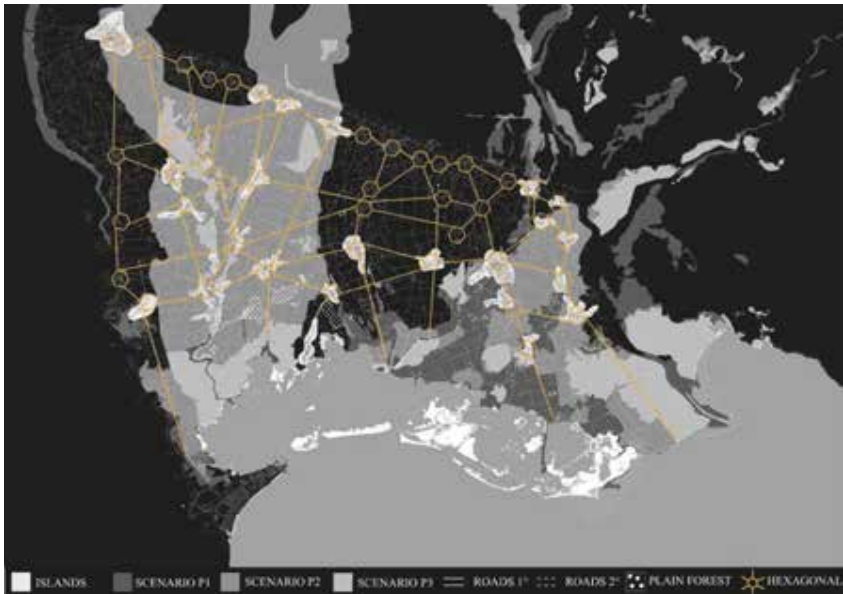

Figure 4 - The hexagonal mesh characterizes the settlements' spatial structure and its infrastructural network, which connects the territory in a capillary way.

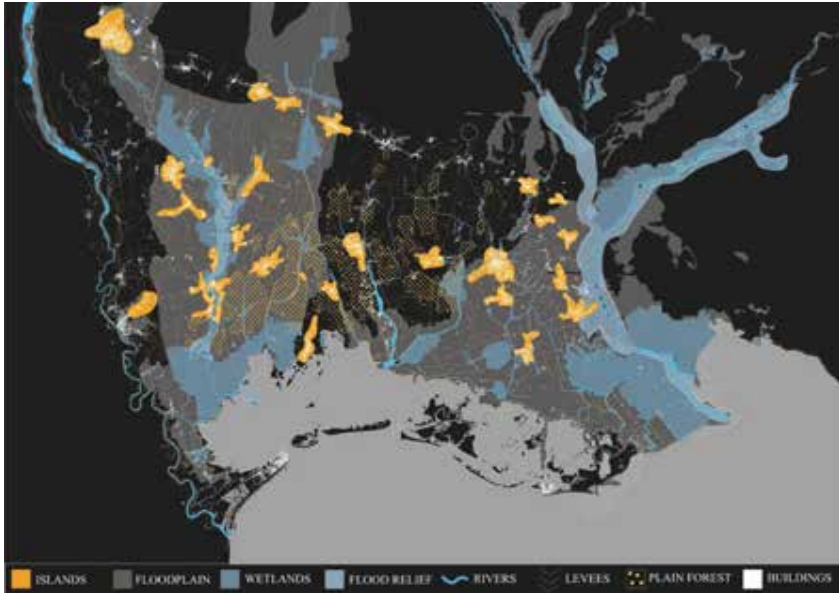

Figure 5 - In the future scenario, maintaining the territory's structural characteristics, the archipelago of the Bassa Friulana plain will be created, making the area habitable, safe and healthy, promoting self-regulation of ecological dynamics, supporting the needs for change.

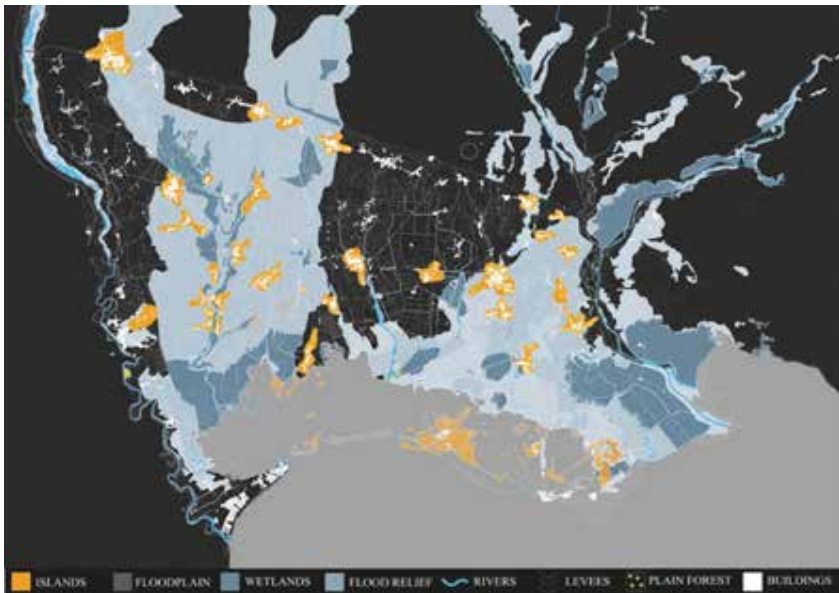

Figure 6 - Lagoons scenarios for the Bassa Friulana plain: a flooding archipelago.

Results. Archipelago e land reclamation: new costal landscapes

The mapping process of the geomorphological structure of the territory and the hydrographic and infrastructural networks on the PAIR scenarios have highlighted some critical issues, but also various potentials. Whether as a result of historical and morphological analyses or projective scenarios, the Bassa Friulana plain has clearly an embedded resilience.

The result of the analysis and interpretation work was summarized in the "map of the archipelago" of the Bassa Friulana (Figure 6) shown above. This is an extreme, but not improbable, vision and the case studies analyzed demonstrate it. The rebalancing of man-environment-settlements must inevitably go through a phase of recovery of the "original landscape", which was generated on environmental dynamics of self-regulation, in particular for the management of water cycles, regulation of outflows following of rainfall intense (water-bomb) and of self-containment of possible flooding, which should be remembered that generated, over two thousand years ago, the well-known "flooded forest", which still today is the landscape matrix of the unity of the landscape "Bassa Pianura Friulana e Isontina" (AP10) and the landscape unit "Laguna e Costa" (AP12) [12]. The trend scenarios outline three areas subject to the risk of "hydraulic danger" in a time gap of 100 years. In the archipelago map we recognized the structural areas with which to associate the strategies of self-regulation, controlled flooding, restoration land reclamation (oasification) and migration. These environmental strategies will act on the structural components and territorial dynamics in the short, medium and long term.

These three hydraulic scenarios have been set with a "return time" that is now more than acceptable (100 years), this choice is supported by the results of the rainfall, analyzing the trend of the rainfall curves of the last twenty years of the Osmer FVG [13]. The rainfall monitoring confirms the choices of the time indicators for the scenarios (100 years) and are consistent with the other environmental data collected: temperature trends, progress of desertification processes in agricultural lands, reduction of the level of biodiversity. All this is due to the phenomena of ecological fragmentation. The coincidence of all these environmental data and the overlap with the data on the settlement dynamics lead to a single result: in these perilagunar territories, the "Friulian deserts", the territorial planning must necessarily start from the environmental reorganization, to avoid natural disasters and catastrophes, but above all to be able to manage the territory over time at lower costs, and triggering more natural and spontaneous processes. For these reasons, ecological networks (RER) and landscape systems (Udp) can no longer be only indicators, but will have to become the new vector for territorial and large urban planning. According to this approach, the environmental frame becomes an urban and territorial frame.

Considering all this, we hypothesized environmental dynamics related to water management to achieve these territorial layouts, using some strategies in the project areas, which consider environmental structures and units as settlement figures for urban development and reorganization:

The islands:

- *The settlement islands* reproduce the original matrix, formed by the integration of anthropic dynamics with environmental characteristics, and recover the figures of the "squares and hexagons" as a form of the territorial structure, identified by Francesco Tentori in his essay (1983) "*Living in the Friuli plain: the settlement, the grounds, the house. The square and the hexagon*" [5]. The planning use of islands (squares and hexagons) allows to encapsulate the reclamation land, restoring the water margin, and

proposing a new balance between mechanical drainage and natural drainage. The hydraulic concept merges the settlement concept for all the inhabited territories of the Lower Friuli plain (friulian deserts) in favor of a structure and an overall functioning that regulates itself, and which also provides for flooding (semi-controlled) as a cyclic regeneration event of the environmental system, and not as a catastrophic event to be excluded. The settlement systems, which derive from the redesign in islands "with squares and hexagons" are resistant thanks to their position and their morpho-typological characteristics, because they belong to ancient systems of "territorial wrecks", born from an agriculture of resistance, in these flooded lands, particularly careful to maintain an environmental and landscape structure (necessary for its survival).

- *The islands of the forest* are wetlands, outcrops or semi-emerged lands that function both as a filter and as a containment device for the waters of the lagoon. These outcrop wetlands form rolling basins and contribute to the overall retention during floods. They are therefore "barrier and backward barrier islands". They refer to natural structures already present in lagoon landscapes and marine habitats, the "velme" and the "barene" (sandbanks), performing an important hydraulic function for the self-regulation dynamics (retention, filtration, speed reduction), but also biological (refluxes and oxygenation of the water, but also sedimentation or stagnation of the water) hypothesized by our scenarios, as well as constituting a first habitat for the numerous fish and bird species of the Lagoon of Marano and Grado. The islands of the forest will allow the direct reformation of the lowland forest, which although small at the beginning, will constitute a fundamental engine for the restoration of the wet forest and peat bogs (recovery of the original landscape and return to the flooded forest).

The waterways:

- *The waterways* within the lagoon play an important ecosystem function. The environmental balance of this area of coast and lagoon, but above all the hydraulic one, is guaranteed almost completely by the system of waterways of the Lagoon of Grado and Marano, and consists of both the internal canals and the rivers that flow here (Stella, Zelina, Muzzanella, Aussa, etc.). The most relevant datum of this system is its mutability due to floods and shoals. This phenomenon is one of the causes of the subsidence of the friulian deserts, because they are artificial soils that rest on sands and silt: they are the reclamation lands. The continuous movement of riverbeds and internal canal beds is the main driver of biodiversity for all species of the Lagoon of Grado and Marano, and for the ecotopes themselves. The lowest levels of naturalness have been recorded in the last 20 years, that is since the embankments have been "plastered". This has made the rivers hanging (they flow between the banks at a higher altitude than the countryside). Another cause has been the dredging of the internal canals of the lagoon, in particular since the dredging has become regular and cyclical: all this has limited the migrations of bacterial populations coming from the animals that live in the seabed (and that die there) and has eliminated the decomposition of plant matter that fell into water. All studies and environmental reports² on the Lagoon of Marano and Grado show that the continuous

² We report below two important geomorphological studies on the role of basins and salt marshes (barene) of the Grado and Marano Lagoon for naturalistic dynamics: Fontolon G. (2010) *Le trasformazioni ambientali della Laguna di Grado e Marano*, ArpaFVG rapporto tecnico UNITS, Trieste; Fontolon G. Covelli S. (2013), *Studio delle aree barenicole della Laguna di Grado e Marano*, ArpaFVG rapporto tecnico UNITS, Trieste.

hydromorphological transformation is the main source of naturalness of the entire lagoon habitat [14], but on the contrary it is also the main problem for the survival of the settlement systems developed on the perilagunar territories. The scenarios that we have elaborated are a proposal to rebalance the environment-human settlements, which starts from the role of water as an environmental frame and a continuity device for the reconstruction of the ecological lagoon network, but above all of the self-regulation processes, which they are based on controlled flooding and on the circulation of “descending and ascending” waters (tidal flows, and dynamics of sandbanks).

- *The water storage tanks: tanks, basins and floodable areas.* The first problem to solve during heavy rainfall is the surplus of the amount of water that the system cannot absorb: the "first rain" and the flood water. The topic solution is to provide natural systems and self-regulation for the management of the expansion of the *overflow volume*, which then reverberates over the whole environmental system (animal species, fauna, soil structure, crops), but even more and with seriousness on the settlement systems (rural villages, inhabited centers) and on all the network infrastructures, in particular on those for the collection and outflow of urban rainwater and on the relative purifiers (critical issues detected especially in the centers coastal beaches such as Grado, Lignano Sabbiadoro and Marano Lagunare). Thus was born the proposal to insert large swath areas in open countryside (with the function of water retention basin) and on “flywheel tanks” (storage tanks) that can be integrated with public spaces (water squares) in urban areas. This system, now widely indicated by the Regional Water Management Plan of the Friuli Venezia Giulia Region, would allow to collect the surplus of first rain or full water and then gradually release it (48-72 hours) into the aquifer, without causing a crisis the hydraulic system, using post-sub-infiltration basins, or simply unloading on open areas with a morphological conformation of the soil suitable to be flooded by water and then, after the event, to empty itself [15]. The proposal, which refers to important studies and experiments of northern Europe³, is therefore to include large flood basins and many small underground storage tanks in the area around the lagoon, which in emergency can contribute to satisfying the expansion of the overgrown volumes and which for the rest of the time are conformed as real environmental units, therefore integrated into the landscape system. These considerations show the importance of both landscape and environmental water for our study area, and above all as a continuous system and matrix of the ecological network for this fragile lagoon and coast system of the Lagoon of Grado and Marano: that's why the shapes of the water, and the forms generated by water are the paradigm of both the analytical and the design part. The scenarios therefore hypothesize a return to controlled "irregularity" in water management, or rather to forms of self-regulation which, however, start from the assumption of returning their spaces to the water of the Lagoon. This can only go through processes of restoration land reclamation (oasification), which lead to an arrangement of the flooded or semi-flooded landscape of the lowland forest, and to the settlement forms (*the square and the hexagon*) in balance with the forms of water.

³ Topos magazine was one of the first landscape architecture magazines to dedicate monographic issues to these water retention systems and hydraulic devices for collecting and infiltrating the aquifer integrated into the overall design of public spaces, parks or entire and vast countryside areas. Topos in the early 2000s published the following 2 issues to these topics: *Water. Design and Management*, Topos n.59/2007, and *Water. Resource and Threat*, Topos n.68/2009.

Discussion. Restoration land reclamation and oasification

Criticality and potential of the results

The "study process" through the mapping of the geomorphological structure of the territory, the hydrographic and infrastructural networks on the PAIR scenarios has highlighted some critical issues and potential. Among these, we highlight the management of water, which on the one hand is necessary for the survival of settlement systems and crops and on the other is a process that progressively reduces the overall level of biodiversity of the lagoon ecosystem. The changeability of the geomorphological structure is the origin of the natural processes that constantly regenerate by exchanging between lagoon and perilagunar habitats (land reclamation), but it is also the origin of the fragility of the settlement system, in contrast to the rigidity of the system fragility, while for settlements it is a safety factor. If we look at the system as a whole, the loss of biodiversity, however, is not positive for anyone, as it leads to greater expenses for ecosystem services, which then transfer to social cost. The scenarios that we proposed arise from an existing antithetical condition, and aim to build a new balance, which arises from the recovery of an original, pre-reclaimed territorial structure, therefore already inherent in the landscape matrices and in the environmental units of the Lagoon of Grado and Marano.

The restoration land reclamation (oasification) is a first solution capable of reconfiguring the environmental and landscape continuity of the peri-lagoon territories, the basic condition for the formation of environmental frames. Bringing water back to the reclaimed lands may seem a little pragmatic, but in reality the analysis of various case studies such as the case of Val Padusa, Cassa del Quadrone and wetlands in the lower Bolognese [16], but also the case experimental, already implemented in this area, in Fossalon, near the Grado Lagoon and the Cona Island, at the mouth of the Isonzo river [17], show how reversibility has worked, especially in terms of time, because it has been shown that marine habitats reform faster and easier than others. The consequent problem is constituted by the consolidation of the same, which should in this case, given the heavy anthropic action of man carried out so far, be accompanied by various types of actions (environmental restoration, renaturalization, monitoring of the seabed and cover-up phenomena, analysis of the processes of modification of the chemical compositions of the soil, reintroductions of birdlife, etc.), especially for the areas cultivated since the 1926 reclamation to date, and then the land reclamation of the 1920s as well as responding to a need for land to be cultivated, they were the solution to various diseases, including malaria, the most important. Today, however, technology and medicine, together with a series of hydraulic devices (water oxygenation) could reduce, if not completely eliminate the latter problem. The return to the pre-remediation condition (oasification) and the archipelago structure are the most relevant results of this research: both for the analysis documents and for the techniques with which we have reconstructed the knowledge framework. Another important fact that we have discovered are the dynamics that led to the current structure (criticality / potential). Understanding the dynamics allowed us to elaborate the overall visions and the detailed project proposals. Restoration land reclamation (oasification) and archipelago are two ideas-tools [18]. The instrument idea is a conceptual device and a programmatic approach⁴, which has allowed us to design a masterplan for the entire territory of the Lower Friuli and Isontina Plain (coast and lagoon territory), which integrates the environmental frame and

⁴ I The concept of "idea-tool" was developed by Franco Purini in 1997 and published in: Purini F. (2000), *Comporre l'architettura*, Laterza, Roma-Bari, pag.29.

settlement models to provide a solution to the problem of ecological fragmentation, and more generally, to the problem of Friulian deserts, without however completely erasing them: in summary we propose to “planning and design with nature” [19].

Criticality and potential of the method

This is a "qualitative" research, it is certainly partial and not exhaustive, and has several problems, which emerged during the mapping. The limit of this method is often linked to the precision of the georeferencing of historical cartography, and the relative level of approximation of the position of the individual territorial systems. We have completed the reconstruction of the territorial knowledge framework also with a screening of historical-literary treatments taken from excerpts from literature, historical and archaeological research and local history texts (especially on land reclamation, economics and agricultural society) and ethnographic research. There are many local authorities that govern this territory, and this implies a strong disaggregation of data, which in some cases are also conflicting and inconsistent between them. In these cases we have reworked the data by interpolation. This research is therefore a qualitative investigation with a transdisciplinary character to solve territorial problems. A substantial part of the study derives from the objective data of the soil: in the geometry of the countryside, in the morphology of rural settlements (farmhouses), in the plant wrecks along ditches and drainage channels and in the conformation of the banks along the lagoon eaves. The method of combining these indicators and the syncretic reading of these traces and landscape constitutes an important method for the reconstruction of the landscape matrices and the basic environmental units of the perilaguna territory of the land reclamation: the Friulian deserts.



Figure 7 - Friulian deserts: portion of land reclamation, area of the case study: Land reclamation of Fossalon between the island of Cona and Grado.

Conclusion. *City beyond the city, or city that floats on the city*

The specificity of the Low Friulian Plain consists in the totality of the territorial form generated by the water and of the settlement structure (Tentori 1983), which without considering the historical and morphological analyzes on the landscape, can still be read today as an archipelago, a territorial figure, an instrument of reading and project. This territorial figure as a planning tool was thus described by Rem Koolhaas and Oswald Mathias Ungers in 1977 in *The city in the city. Berlin: a green archipelago*:

[*"For ten years, the notion of urban archipelago or city-archipelago has been increasingly recurrent in the debate on urbanism, since they well describe both the way in which develop urban territories and because they explicitly explain how they should be designed. In our metropolitan condition, where the explosion of urban or suburban phenomena has individually blurred the distinction between city and countryside, this "terraqueuse" figure, borrowed from physical geography, suddenly seems to impose itself in the field of human geography as a capable meta form to translate and structure the shapeless, éclatée, diffuse, dispersed or multipolar city. Plural and identity at the same time, shaped by all the imaginary of navigation, it conveys the promise of a new convention or a new dialectic on the city and the territory, nature and culture, which overcome the classic opposition between cities and countryside. We can say that the archipelago is today one of the great possible figures of the hyper-city or the post-urban metropolis, able to overcome the obsolete dialectic between city and countryside "*by S. Marot, in F.Hertweck, S. Marot, *La Ville Dans La Ville: Berlin: Un Archipel Vert*, Lars Muller Publishers, Baden, 2013]

Our case study obviously has a different scale, urban layout and settlement origin, but, to paraphrase Koolhaas and Ungers, we could talk about *city beyond the city, or city that floats on the city*. The use of this figure together with the strategy of restoration land reclamation have allowed us to draw up territorial scenarios and to elaborate an overall masterplan for the Friulian deserts, which starts from the concept of renaturalization, from the need to increase biodiversity by reducing fragmentation. In summary we propose to reconstruct the environmental continuity (through the restoration land reclamation) at different scales, then to configure through the watershape (considered both as form and as matter: solid water) an ecological perilagunar network for the Friulian deserts, which, however, is also new at the same time settlement form: a new landscape. This approach and the first results allow us to continue the development of research in architectural themes, therefore studying new settlement typologies consistent with the coastal archipelago of the Low Friulian Plain and its genesis. We have already started to identify these new water living forms in “lagoon shelters”, “agro desert camps” and “stilt countryhouses”.



Figure 8 - Experimental settlement typologies for Friulian deserts, from left: “lagoon shelters”, “agro desert camps” and “stilt countryhouses”.

Acknowledgements

We would like to acknowledge the contribution and support of the *Municipality of Latisana Green Plan* research group (Eleonora Ceschin, Luca Del Fabbro Machado, Pier

Luigi Martorana, Marco Croatto) and the *Integrated design laboratory of city, territory and landscape* a.y. 2018-19 of the University of Trieste (Alfredo Altobelli, Alessandra Marin, Sonia Prestamburgo), for their engagement in the investigation on the landscape unit.

Our thanks go to prof. Giovanni Fraziano who provided valuable perspective and inspiring insight into the landscape unit as advisor of two master thesis [Gianluca Calligaris e Lorenzo Rigonat].

We are very grateful to prof. Giovanni Corbellini, who encouraged the critical discussion and review of Francesco Tentori's "Abitare nella pianura Friulana" since the exhibition and seminar *Fahrenheit Tentori* held in IUAV on November 11th, 2019. This research represents a first attempt to enlighten it.

References

- [1] Nievo I. (1964) - *Le confessioni di un italiano*, Einaudi, Torino.
- [2] Bini, G. (2008) - *I boschi della Bassa friulana*, La bassa, collana 72, Latisana.
- [3] AA. VV. (1996) - *Atlante di Passariano 1996: Indagini e proposte per la vita futura della villa e del suo paesaggio culturale*, Fondazione Benetton Studi Ricerche, Treviso.
- [4] Pasolini P.P., regia di Brunatto P. (1974) - *Pasolini e... la forma della città*, documentary.
- [5] Tentori F., (1983-87) - *Abitare la pianura friulana: l'insediamento, il sedime, la casa*, ed. Corbellini G. I.U.A.V. Dipartimento Progettazione Architettonica, Venezia.
- [6] AA.VV. (2018) - *PPR FVG Scheda Ambito di Paesaggio Bassa pianura friulana e isontina*, Regione Autonoma Friuli Venezia Giulia.
- [7] Augé M. (1992) - *Non-Lieux. Introduction à une anthropologie de la surmodernité*, Le Seuil, Parigi.
- [8] Rossano F. L.M. (2016) - *Floodscapes: Contemporary Landscape Strategies in Times of Climate Change*, Ph.D. dissertation, ETH, Zürich; Rossano F. L.M. (2020) - *Floodscapes: Contemporary Landscape Strategies in Times of Climate Change*, Nai010 publishers, Rotterdam.
- [9] Venudo A., Ceschin, E., Del Fabbro Machado, L. (2020) - *Laboratorio Paesaggio Latisana*, EUT, Trieste.
- [10] AA.VV. (2015) - *Impatti dei cambiamenti climatici sul territorio fisico regionale*, Regione Autonoma Friuli Venezia Giulia;
- [11] AA.VV. (2016) - *Piano di stralcio per l'Assetto Idrogeologico*, Regione Autonoma Friuli Venezia Giulia.
- [12] AA.VV (2018) - *AP10 Scheda Ambito di Paesaggio Bassa Pianura Friulana e Isontina, AP12 Scheda Ambito di Paesaggio Laguna e Costa*, Regione Autonoma Friuli Venezia Giulia; PPR-FVG - Piano Paesaggistico Regionale (2018), dal sito: 2020<https://www.regione.fvg.it/rafvfg/cms/RAFVG/ambiente-territorio/pianificazione-gestione-territorio>, consultato in data 17.06.2020
- [13] Osservatorio Meteorologico FVG – OSMER, Agenzia Regionale per l'Ambiente FVG: <https://www.osmer.fvg.it/home> , sito consultato in data 29.05.2020.
- [14] Fontolon G. (2010) - *Le trasformazioni ambientali della Laguna di Grado e Marano*, ArpaFVG, rapporto tecnico UNITS, Trieste.
- [15] *Water. Design and Management*, Topos n.59/2007.

- [16] Alberti S. (1993) - *La sbonifica: vicissitudini della Cassa del Quadrone e di altre zone umide della bassa bolognese*, regia di Pesce G.B., Documentary video, Istituto Nazionale per la fauna selvatica, Comune di Medicina (BO).
- [17] AA.VV (2003) - *Gorizia e provincia. Grado, la laguna, il Collio, Redipuglia, l'Isonzo*, Touring Club Editore, Milano.
- [18] Purini F. (2000) - *Comporre l'architettura*, Laterza, Roma-Bari.
- [19] MacHarg I.L. (1989) - *Progettare con la natura*, Franco Muzzio Editore, Padova, (*Design with nature*, New York, Doubleday & Company, 1969).

ANALYSIS OF THE THEORETICAL SETTLEMENT SCENARIO IMPLEMENTED BY THE MUNICIPAL PLANS. THE CASE STUDY OF THE ROMAGNA COAST MUNICIPALITIES

Francesco Zullo¹, Lorena Fiorini¹, Alessandro Marucci¹, Bernardino Romano¹

¹University of L'Aquila – DICEAA, Via Gronchi 18 – 67100 L'Aquila

Tel. 0862434104, Fax. 0862434143, e-mail: francesco.zullo@univaq.it

Abstract - In Italy, the transformative predictions of the municipal urban planning instruments are very often far away from the socio-economic dynamics related to characteristics of the territories in which they operate. In fact, the political component considers the oversizing of urban transformative projections as a solution to improve the situation of the territories in crisis for several aspects. This happens regardless of the geographical location of the municipality and even the recent regional laws on the stop/containment of land consumption are able to reverse this course, also because they often add the sentence "without prejudice to the provisions in force" or similar. In many cases it must be considered the date of approval of the urban planning instrument which over time leads to the implementation of different varying, which are necessary both to amend the urban projections and to update their contents according to the changed social, economic and environmental conditions. In particular, this work analyses the projections of the urban planning instruments in force in the coastal municipalities of Emilia-Romagna. Through this analysis, the work aims to highlight how the settlement forecasts contained in the municipal planning instruments can change the future settlement structure in the case study area. The coastal strip investigated is already highly urbanized but also home to an extremely fragile environment such as the coastal one, which is one of the most urbanized of the Mediterranean. It extends for about 150 km, equal to the 10 % of the entire Adriatic coastal sector, and it has been characterized, over time, by intense urbanization processes, particularly in the 500 m strip from the (coastline). Currently, the sections that remain free from constructions are little less than 50 km (about one third of the total extension) and they are more concentrated in areas where the environmental conditions (swampy areas, river mouths) are less suitable for urbanization. They have a population of about 525 000 units (11 % of the regional population), a value higher than the population of regions such as Molise or Valle d'Aosta, although it covers an area of about 1500 km². Moreover, they are characterized by a population density of 350 inhabitants/km², which is higher than both the regional value and the national value. Currently, the urbanized areas are around 290 km² but the theoretical scenario of the plans implemented would see the urban areas rise to 340 km² (50 % of these transformations involving the municipalities of Rimini and Ravenna). The situation is certainly more critical for the coastal strip where the current urbanization rate is about 50 % and the municipal planning instruments provide for an additional 7,5 km² of areas that can be transformed along this area which should not be neglected from an environmental point of view. Most of these areas of urban expansion affect the residual coastal spaces, but the construction of a new tourist settlement is also planned, which would eliminate another 2 km of coastline in the municipality of Ravenna, in an area affected by 2 Special Areas of Conservation (SAC).

Introduction

The presented research paper focuses on the urban planning tools used in the municipalities along the Romagna coast, an area highly representative of the Adriatic seaside tourism sector as a whole. By analysing the changing trends expressed through municipal urban planning tools, the paper aims to highlight ways in which urban planning projections can alter the future layout of an already densely urbanised area, but which is still home to an extremely fragile environment like that of the coast [6], [15], [25], [1]. Indeed, we are referring to a vibrant ecosystem where natural processes and anthropogenic transformations interact modifying the physical, geological and morphological features of the sandy coastlines. Also, the persistent pressure exerted upon these areas stems from the high population density recorded there: in 2012, more than 30 % of the population of the European Mediterranean countries lived near the coast [13] with estimates of over 170 million in 2025 [29]. Today in Italy, over 17 million people live in coastal municipalities with a population density equivalent to 400 inhabitants per square kilometre, which is double the national figure. From an economic point of view they are very important locations [22] and, at the same time, environmentally fragile. Historically, urban planning tools have often supported approaches which gave greater priority to socio-economic aspects whilst, in practice, proving to be less attentive to environmental issues. This is partly attributable to the fact that environmental legislation has only become more significant and established over the last thirty years. Furthermore, transformative projections of municipal urban planning tools are often detached from the socio-economic dynamics of the applicable territory [26], [8]. The excessive scale proposed by urban planning projections is seen by politicians as providing a solution to the challenges facing territories which are experiencing several crises. This happens irrespective of the geographical location of the municipality and not even the recent regional laws on the cessation/containment of land consumption succeed in reversing the trend to a certain extent not least because of the inclusion of the phrase "subject to the provisions in force". In many cases, it is necessary to add to that the age of the tool which over time leads to the implementation of different variants both to scale down the projections and to update their contents according to the changed social, economic and environmental conditions. This research shows the possible settlement scenarios of the Romagna riviera's municipalities and then analyses a 1 km coastal strip from the shoreline, which is where the transformative pressures are most concentrated. Primarily linked to tourist activities associated with the marine environment's economy. After analysing the trends in progress, the paper concludes by proposing a decision-making support tool to be used when evaluating the plans.

Study area

The work is focused on the municipalities of the Romagna Riviera, which is one of the most urbanised sectors of the Adriatic coast. It is a linear stretch of about 150 km, equivalent to approximately 10 % of the entire Adriatic coast. It is a low-lying coast comprising of sandy and pebble beaches covering a fairly large surface area with a vast lowland behind [5]. These morphological characteristics have strongly influenced the dynamics of local settlement [13], [8] which has recorded one of the highest rates of soil depletion in the last 50 years. Notably, in the 500 metres strip of shoreline, where urbanisation



Figure 1 - Study area.

has almost halved the kilometres of coastline free from construction at a rate of 1 km every year [24]. The Romagna coast covers 14 of the 328 regional municipalities, including two provincial capitals (Ravenna and Rimini), with a total area of 1500 km², representing about 7 % of the entire regional area (Figure 1). According to the Istat data updated until 2019, about 525 000 inhabitants (12 % of the regional population) live in this area, which is higher than the local populations of regions such as Molise or Valle d'Aosta. The population density is about 350 inhabitants/km², against 200 inhabitants/km² of the regional and national average. Between 2011 and 2019, the population increased by about 19 000 units (more than 2300 new inhabitants every year), representing 16 % of the increase recorded in the same period for the entire region. From an economic standpoint, the taxable income of the surveyed municipalities has increased by 15 % in the last 8 years (2011-2018) and the income per capita for 2018 is close to the national average (20 000 euros) for almost half of those municipalities. The lowest amount is recorded for Goro with just over 12 000 euros.

As for the state of municipal planning, urban plans refer to two distinct regional laws: the L.R. 47/1978 and the ex L.R. 20/2000 subsequently repealed and then replaced by L.R. 24/2017 (art.79). As for the state of municipal planning, urban plans refer to two distinct regional laws: the L.R. 47/1978 and the ex L.R. 20/2000 subsequently repealed and then replaced by L.R. 24/2017 (art.79). The first law, therefore, refers to all the Municipal Urban Plans (PUC) drawn up between 1972 and 2001. The plans in force in the municipalities of the study area were all approved after 2010 except for the municipalities Goro (1997), Misano Adriatico (1999), and Comacchio (2002). As for the state of municipal planning, urban plans refer to two distinct regional laws: the L.R. 47/1978 and the ex L.R. 20/2000 subsequently repealed and then replaced by L.R. 24/2017 (art.79). The first law, therefore, refers to all the Municipal Urban Plans (PUC) drawn up between 1972 and 2001. The plans in force in the municipalities of the study area were all approved after 2010 except for the municipalities Goro (1997), Misano Adriatico (1999), and Comacchio (2002) (Source: <http://wwwservizi.regione.emilia-romagna.it/territorio/pianiurbanisticicomunali/StatoVigenza.aspx>) even though some of these entities have already started the process of drawing up the General Urban Plan (PUG), thereby complying with the provisions of L.R.24/2017 to date only the Cervia Municipality has a PUG drawn up in accordance with the latter. The territorial footprint, albeit widely

anthropised, still holds significant environmental value [19][20][28] testified to by the presence of 21 sites (SAC's and SPA's) of the Natura 2000 network, mostly located in the northern coastal regions of the Ravenna and Comacchio municipalities. These are largely residual environments [13], [11] in which anthropic transformation processes are less intense due to physical conditions (marshy areas, salt pans, river mouths) not suitable for settlement. Some small nature reserves and a Regional Park (Parco Regionale del Delta del Po) are located in these areas, within the boundaries defined by the SPAs and SACs indicated above.

Materials and methods

The data used in this survey originates from several sources. In particular, data from the mokaGIS portal (http://www.mokagis.it/html/applicazioni_mappe.asp) was extracted from the CSPs (Municipal Structural Plans) from 5 of the 14 coastal municipalities. These tools divide the territory into urban, brownfield and rural, and planning is divided into areas. The most significant infrastructures and facilities are also reported as indicated by L.R. 20/2000. The urban planning projections for the remaining municipalities have been extracted from the minERva portal (<https://datacatalog.regione.emilia-romagna.it/catalogCTA>) except for the Cervia municipality where the vector data of the recent PUG (approved in 2018) is not available. From the PSCs, territories defined as suitable for urbanisation have been selected, while for the other municipalities' systems, all the transformative categories with an urban destination have been extrapolated. The following zoning uses have been taken into account for this last point: residential completion, residential expansion, productive-touristic areas, technological infrastructure and public service areas. As a result, a single source of information was obtained containing all the settlement expansion projections for each municipality on the Romagna coast. To gauge the extent to which the projected plans have been realised, the level of soil waterproofing and the latest transformative dynamics along the coastal system including several map databases have been used. The recent soil waterproofing trends (2012, 2016, 2018) have been analysed through the database of the Istituto Superiore per la Protezione e la Ricerca Ambientale (ISPRA) (<http://geoviewer.isprambiente.it/index.html?config=config.xml>) which provides an information layer showing the geographical distribution of the waterproofing areas in the country's soil at a resolution of 10m/pixel. Land use maps (minimum cartographic unit of 0,16 hectares, minimum size of 7 metres for linear development elements) updated until 2017, allowed the analysis of aspects related to the dimensions of existing urban planning tools in relation to the urban areas currently present in the territories of the municipalities surveyed. It is worth pointing out that urbanisation is not synonymous with waterproofing. Waterproofed surfaces are those covered by layers of water-resistant material that prevent the absorption of surface water. This includes either built-up soil or land intended for other purposes requiring paving such as streets, public squares and car parks and all those instances where the layers of natural soil are completely removed and replaced with other materials that improve the stability and non-deformability of the surfaces. Urbanised surfaces, on the other hand, are those intended for urban use, with replacement or maintenance of the natural soil. This type of surface includes parts of built-up soil and those intended for incidental functions of the settlement, such as public and private gardens, sports facilities, dirt roads and other service areas. Extra-urban roads are excluded from the calculation. These areas are

the same as those surveyed under heading 1 in the CORINE Land Cover classification, which was also adopted by the Emilia Romagna Region for the preparation of the various land use maps. The current settlement conditions and those resulting from the possible implementation of the projections of the plans have been analysed with the help of appropriate urban planning indicators used for some time in studies in this sector. The indicators used are the following:

Impermeabilization/urbanization density (a): $DI - DU = \frac{\sum A_i}{A_u}$ (%)

Planned Urban Surfaces Index (b): $IEUP = \frac{A_p}{A_{urb}}$ (%)

where:

A_i = Impermeable/urbanised areas

A_{urb} = Urbanised areas

A_p = Urbanised area foreseen in the urban planning tools currently in force: sum of areas destined for residential use (expansions, developments, land parceling), areas destined for services (social, cultural, technological) and areas destined for productive activities (craft and industrial)

A_u = Statistical unit considered (Municipality or municipal coastal belt)

Both indicators were drawn up on a municipal basis. Index (a) indicates the percentage of municipal territory affected by actual waterproofed/urbanised areas. Hence, providing indicators of the level of degradation of the natural matrix. Index (b), on the other hand, represents a typical settlement behaviour index as it shows the number of times that the transformation projections of the current urban planning tool multiply what has been achieved within the surveyed municipality. A detailed analysis has also been carried out in the 1 km coastal strip, which is substantially affected by the settlement transformations linked to the marine economies.

Results

The urban areas currently located in these territories amount to about 290 km², equivalent to 12 % of the regional total with an urbanisation density that reaches 18 %, a value that is higher than both the regional (11 %) and the national figure (10 %). These urbanised areas are not uniformly distributed across the various municipalities: more than 50 % of them are located in the capital cities of Rimini and Ravenna. The analysis of the values of the DU index, together with those found for the DI, in the surveyed municipalities are shown in Figure 2. It is interesting to note that only 3 of the 14 municipalities have a DU value below 10 %. These are the municipalities located north of the regional coastal system in which the territory is marked by the presence of vast wetlands and swampy areas that have been less affected by the transformative trends that have affected the entire Italian coastal system, especially from the Second World War until the early 2000s (Romano et alii, 2017). On the contrary, the municipalities with extremely high index values reaching peaks of over 70 % in the municipalities of Riccione and Cattolica, both famous tourist destinations in the area studied

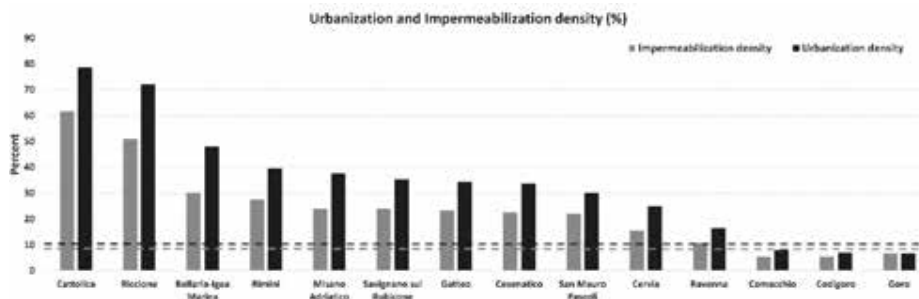

Figure 2 - DU indicator trend (in black) and DI (in grey) for the Romagna coast municipalities. The dotted lines represent the comparable values measured on a national scale.

since the beginning of the last century. An analysis of the density of waterproofing of the municipal soils shows a similar trend with values slightly lower than those previously reported, but which once again underline the high settlement pressure that distinguishes these territories. The values range from 5 % in the municipalities of Goro, Codigoro and Comacchio to 50 % in Riccione and 60 % in the municipality of Cattolica. The study of the relationship between the urbanised and the waterproofed surface is also noteworthy. This indicator provides information on the level of soil waterproofing in urban areas and hence is essential in the study of urban heat island phenomena or the influence of these surfaces on the level of water runoff (Arnone, 2018; McCarthy, 2010). In fact, in cities where the soil is highly waterproofed, the high water runoff strongly influences the capacity of the sewage system. The more soil is waterproofed, the greater the volume of water that flows superficially at the catchment level, reducing the time needed for flood formation and potentially causing more harmful flooding. Of the 290 km² of the surface area assigned for urban use, 193 km² are physically waterproofed (67 %) although the situation differs between municipalities.

The highest levels are found in the municipalities of Goro (83 %) and Codigoro (77 %), whose environmental conditions have led to a high level of soil waterproofing. Levels slightly lower than average for the area affect the municipalities on the southern coast of the region except for the municipality of Cattolica with approximately 80 % of urban areas covered by waterproofing materials. Shifting the focus along the coastal strip (1 km from the shoreline) it can be seen that 25 % of the total urbanised areas are concentrated along this area which is covered by urban surfaces for over half of its size (55 %). It is, however, important to point out that the value range is wide: Goro has a value equal to 1 % while 10 of the 14 municipalities surveyed reach values above 70 %, half of which have a value above 90 %. The above factors largely express the strong anthropic pressure along the coastal system. The ratio between the two different types of transformed surfaces considered in this paper is 65 % in this area with the highest in the municipality of Cattolica (75 %) which has almost entirely transformed the coastal sector administered. The analysis of the transformative projections of the municipal urban planning tools allows us to know the different settlement strategies in the various municipalities not only in quantitative terms but also by zonal typology as, for some municipalities in the area of interest, the information on the zonal subdivision of the plan is also reported. The plans provide for a further 48 km² (Cervia was excluded from the

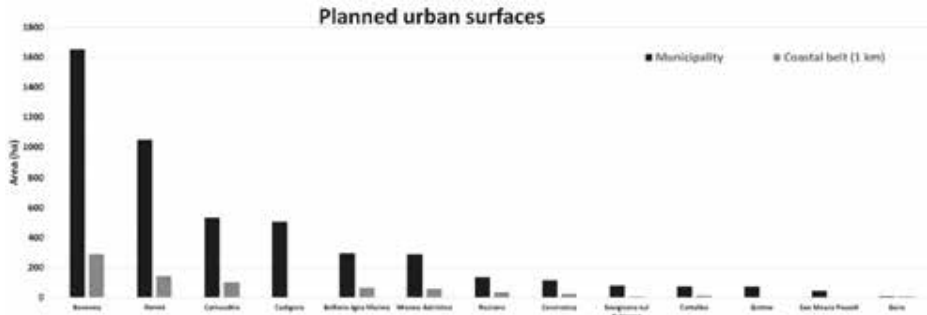

Figure 3 - New urban expansions foreseen by municipal plans. In black for the entire municipality, in grey only for the coast (1 km from the shoreline).

analysis) of surface area to be converted to urban use, one-sixth of which is located in the fragile coastal strip. The histogram in Figure 3 illustrates the situation for each municipality surveyed. Only 3 municipalities do not foresee further transformations along this area: Gatteo, San Mauro Pascoli and Codigoro. For the first two, the reasons are linked to the almost complete urbanisation of this territory while for the third the motives are morphological. Higher values can be found in the areas of the municipalities of Riccione, Cesenatico and Bellaria-Igea Marina where these settlement expansions are well over 20 % of what is foreseeable by the respective plans. The complete implementation of these forecasts would increase the rate of urbanisation to 63 %.

Also interesting is the analysis carried out using the information about the different types of transformation foreseen. It should be pointed out that these zonal categories have been traced back to those of Ministerial Decree 1444/68 through a careful reading of the synoptic description contained in the geographical file database. The results are shown in the diagram in Figure 4. The "Urbanisable Territory" category extracted from the PSC has not been included because it is not possible to attribute this typology to a single synoptic description sensu D.M. 1444/68. However, it should be pointed out that of the 113 ha of the territory referred to this category, 42 ha have yet to be implemented, representing approximately 37 % of the total. On the whole, as shown in Figure 4, more than 60 % of the projections in these territories are related to residential development areas and tourist production areas. The high concentration of the latter type category along the coastal strip can also be analysed by comparing the total number of tourist accommodation areas in the municipalities with those allocated in this area: 60 % is located along this system but for some municipalities (Cesenatico and Rimini) this value exceeds 90 %. Almost all of the B zones have been set up, while a fifth of the D zones is yet to be implemented. Some of these new projected areas (figure 4 on the left) are located right next to the Natura 2000 Network sites, where the residual beauty of the natural environment in a highly anthropised environment certainly attracts new possible accommodation facilities with direct and indirect effects on the very functionality of the network. As far as this last aspect is concerned, it should be noted that the anthropic pressure on this system is already very high: the urbanisation rate of the soils in an area around 1 km from the present sites in the municipalities of the area surveyed is currently equal to 26 % with the new projected areas that, if implemented, would bring this



Figure 4 - Planned but not yet implemented tourist area close to some Natura 2000 network sites (left). Radar diagram showing the percentage breakdown of the different zonal categories in relation to the total forecast (in blue), while the residual plan (in %) for each of them is shown in orange (right). The data has been processed for the whole coastal strip.

value to 30 %. Figure 4 shows that 6 % of the total projected areas are new residential expansion areas (12 % still to be implemented), while public services and technological infrastructure combined account for about 35 % of the total. With regards to the public services category, it is important to underline that a large part of the approximately 3 km² still to be implemented is related to categories of services that involve low soil waterproofing (areas for green spaces, parks, playgrounds and sports) thereby safeguarding part of the essential ecosystem services.

The IEUP value is instead equal to 20 % with a range of values varying between 4 % in the municipality of Goro and up to 43 % more than in the municipality of Codigoro. As mentioned above, the information content of this indicator is directly connected with the settlement behaviour of the municipality to which it relates and is even more relevant when compared with the demographic variation (DV) registered in the decade before the approval of the municipal urban planning tool (Figure 5). It is clear from the analysis how the dimensions of the new settlement areas take little or no account of past demographic dynamics, continuing to be linked to hypothetical development models that are often disregarded both on the economic side and on that of the actual feasibility of the planned urban layout. Municipalities with substantially stable demographic dynamics ($0 < DV \leq 5\%$) show IEUP values ranging between 10 % and 30 %. These are well-known seaside resorts that have further invested in new tourist accommodation and production areas. On the contrary, coastal resorts less frequented by mass tourism but with more dynamic demographic trends ($15\% < DV < 30\%$) show IEUP values below 15 %. This probably is also related to a smaller administered coastal sector of surface area. As far as the 1 km strip from the shoreline is concerned, it should be noted that for 8 of the 13 municipalities considering the IEUP value does not exceed 10 % while values higher than 20 % are reached in the areas administered by the municipalities of Ravenna and Misano Adriatico.

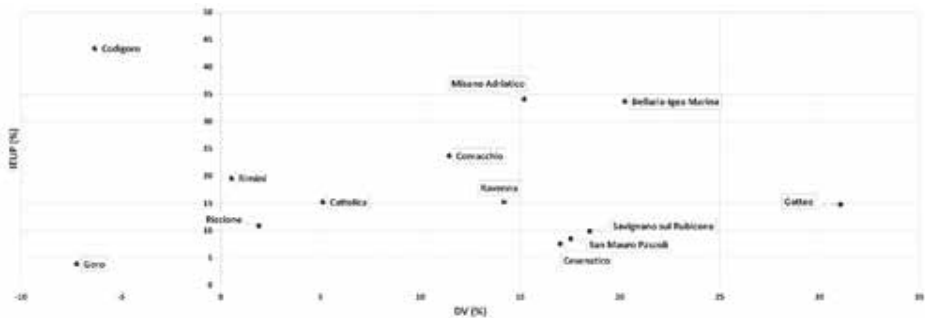

Figure 5 - Dispersion graph showing the IEUP values compared with the demographic trends of the respective municipality.

Conclusions

The coastal environment itself is an extremely diverse habitat consisting of a wide variety of ecosystems which are of primary importance for long-term conservation. Tourist exploitation and industrialisation have strongly accentuated the anthropic impact on these systems since the early years of the last century and, as demonstrated in this paper, do not seem to have stopped. The incidence of high urban development and mass seaside tourism on the coastal sedimentation trends is such that it now requires various and widespread conservation measures along the Italian peninsular coast [4], [11], [17]. To this must be added the increase in the frequency with which sea storms and floods occur [2], [16], [7] which have created and cause considerable environmental damage in addition to economic losses. The Romagna coast has suffered a number of these events which have intensified since 2000 [21]. The region has already financed several important beach rehabilitation projects (2002, 2007, 2016) which highlight how the issue of coastal conservation plays a major role in regional policies. Also, more than 30 million Euros have been allocated by the Regional Council for 10 regeneration and redevelopment projects along some stretches of the waterfront (<https://www.regione.emilia-romagna.it/notizie/2019/ottobre/turismo-riqualificazione-della-costa>) together with another 25 million Euros for the regeneration of hotels and accommodation facilities. As pointed out in this paper, the urban conversion of soils represents an important threat to the integrity and functioning of the coastal environment [26], with urban planning tools that continue to support old models of tourism by designing new areas to be transformed among the remaining natural environments, thus intensifying the anthropic pressure in the already highly urbanised coastal territorial mosaic. The recent urban dynamics (2012-2018) examined along the coastal strip show a decreased transformative impact (23 ha waterproofed) with more localised interventions in the sectors of the municipalities of Ravenna and Rimini. It should also be pointed out that in 2017 the region adopted a law (n.24) regulating the use and protection of the territory, which contains measures that favour urban regeneration and the containment of soil wear (art.5). This law provides for a phase of updating and adaptation to the new rules of existing territorial governance measures through the drafting of the WFP aimed at promoting these important measures in the regional context. Entered into force on 1 January 2018, the new law requires municipalities to start the approval procedure for the new WIP within three years,

which must then be completed within the next two years. Until then, it is possible to continue to transform the territory in accordance with the current legislation (Article 4), through a series of appropriate measures. As mentioned above, there are still 7,5 km² of land intended for urban use but not yet implemented along the coastal strip. It could, therefore, prove useful to build a geographically applied database for the whole coastal system to be built with urban/environmental information aimed not only at real-time monitoring of land-use transitions but also as a tool for public awareness of what is happening in these areas of fragile environmental balance. Such a technological platform would fully integrate into the environmental assessment procedures of the plans (SEA), thus optimising the possible location of the newly settled areas. This would result in an improvement in the efficiency of the geographical location of these sites from the perspective of a touristic economy that responds to logical reasons of regional significance and less easily influenced by simple localisations that consider little or nothing of the delicate equilibrium of the ecosystems along the shores. It would, therefore, be a tool with a strategically driven vision capable of directing territorial policies, favouring actions of environmental regeneration where conditions permit, but at the same time it would also be effective in promoting actions of relocation/removal of areas that could potentially have effects on diverse and essential ecosystem services, ensuring in fact more sustainable transformations in the long run.

References

- [1] Acosta A.T.R., Carranza M.L., Izzi C.F., (2009) - *Are there habitats that contribute best to plant species diversity in coastal dunes?* Biodiversity Conservation 18, 1087. DOI: <https://doi.org/10.1007/s10531-008-9454-9>.
- [2] Armaroli C., Duo E., (2018). *Validation of the coastal storm risk assessment framework along the Emilia-Romagna coast.* Coastal Engineering, Volume 134, April 2018, Pages 159-167. DOI: <https://doi.org/10.1016/j.coastaleng.2017.08.014>
- [3] Arnone E., Pumo D., Francipane A., La Loggia G., Noto L.V., (2018) - *The role of urban growth, climate change, and their interplay in altering runoff extremes.* Hydrological Processes. Volume 32, Issue 12. Pages 1755-1770. DOI: <https://doi.org/10.1002/hyp.13141>
- [4] Bonaldo, D., Antonioli, F., Archetti, R. et al. (2019) *Integrating multidisciplinary instruments for assessing coastal vulnerability to erosion and sea level rise: lessons and challenges from the Adriatic Sea, Italy.* Journal of Coastal Conservation 23, 19–37. <https://doi.org/10.1007/s11852-018-0633-x>
- [5] Brondi A., Cicero A.M., Magaletti E., Giovanardi F., Scarpato A., Silvestri C., Spada E., Casazza G., (2003) - *Italian Coastal Typology for the European Water Framework Directive.* In: Proceedings of the Sixth International Conference on the Mediterranean Coastal environment. MEDCOAST E 03, E. Özhan 7-11 October 2003, Ravenna. Vol II, 1179–1188.
- [6] Carranza M.L., Drius M., Malavasi M., Frate L., Stanisci A., Acosta A.T.R., (2018) - *Assessing land take and its effects on dune carbon pools. An insight into the Mediterranean coastline.* Ecological Indicators. Volume 85, February 2018, Pages 951-955. DOI: <https://doi.org/10.1016/j.ecolind.2017.10.052>.

- [7] Ciavola P., Armaroli C., Chiggiato J., Valentini A., Deserti M., Perini L., Luciani P., (2007) - *Impact of storms along the coastline of Emilia-Romagna: The morphological signature on the Ravenna coastline (Italy)*. Journal of Coastal Research, 540-544. Retrieved June 17, 2020, from www.jstor.org/stable/26481647.
- [8] Colavitti A.M., Usai N., Bonfiglioli S., (2012) - *Urban Planning in Italy: The Future of Urban General Plan and Governance*. European Planning Studies 21, 167–186. DOI: <https://doi.org/10.1080/09654313.2012.722913>.
- [9] Couch C., Leontidou L., Petschel-Held G., (2007) - *Urban Sprawl in Europe: Landscapes, Land-use Change and Policy*. Blackwell Oxford.
- [10] Corbau C., Simeoni U., Melchiorre M., Rodella I., Utizi K., (2015) - *Regional variability of coastal dunes observed along the Emilia-Romagna littoral, Italy*. Aeolian Research. Volume 18, September 2015, Pages 169-183. DOI: <https://doi.org/10.1016/j.aeolia.2015.07.001>.
- [11] Di Risio M., Bruschi A., Lisi I., Pesarino V., Pasquali D., (2017) - *Comparative Analysis of Coastal Flooding Vulnerability and Hazard Assessment at National Scale*. Journal of Marine Science and Engineering. 5(4):51. DOI: <https://doi.org/10.3390/jmse5040051>
- [12] Drius M., Carranza M.L., Stanisci A., Jones L., (2016) - *The role of Italian coastal dunes as carbon sinks and diversity sources. A multi-service perspective*. Applied Geography Volume 75, October 2016, Pages 127-136. DOI: <https://doi.org/10.1016/j.apgeog.2016.08.007>
- [13] European Union (2012) - *Sustainable tourism in the Mediterranean*, catalogue number: QG-31-13-573-EN-N ISBN: 978-92-895-0667-0 (2012), 10.2863/69472 Available at: <http://cor.europa.eu/en/documentation/studies/Documents/sustainable-tourism-mediterranean/sustainable-tourism-mediterranean.pdf>
- [14] Falcucci A., Maiorano L. & Boitani L., (2007) - *Changes in land-use/land-cover patterns in Italy and their implications for biodiversity conservation*. Landscape Ecology 22, 617–631. DOI: <https://doi.org/10.1007/s10980-006-9056-4>
- [15] Fiorini L., Zullo F., Romano B., (2017) - *Urban development of the coastal system of the Italian largest islands: Sicily and Sardinia*. Ocean & Coastal Management. Volume 143, 1 July 2017, Pages 184-194. <https://doi.org/10.1016/j.ocecoaman.2016.12.008>.
- [16] Martinelli L., Zanuttigh B., Corbau C., (2010) - *Assessment of coastal flooding hazard along the Emilia Romagna littoral, IT*. Coastal Engineering Volume 57, Issues 11–12, November–December 2010, Pages 1042-1058. DOI: <https://doi.org/10.1016/j.coastaleng.2010.06.007>
- [17] Martinelli L., Zanuttigh B., De Nigris N., Preti M., (2011) - *Sand bag barriers for coastal protection along the Emilia Romagna littoral, Northern Adriatic Sea, Italy*. Geotextiles and Geomembranes. Volume 29, Issue 4, August 2011, Pages 370-380. DOI: <https://doi.org/10.1016/j.geotexmem.2010.11.010>
- [18] McCarthy M.P., Best M.J., Betts R.A., (2010) - *Climate change in cities due to global warming and urban effects*. Geophysical Research Letters 37, L09705. DOI: <https://doi.org/10.1029/2010GL042845>
- [19] Morri E., Pruscini F., Scolozzi R., Santolini R., (2014) - *A forest ecosystem services evaluation at the river basin scale: Supply and demand between coastal areas and*

- upstream lands (Italy)*. Ecological Indicators Volume 37, Part A, February 2014, Pages 210-219. DOI: <https://doi.org/10.1016/j.ecolind.2013.08.016>.
- [20] Paganelli D., Marchini A., Occhipinti-Ambrogi A., (2012) - *Functional structure of marine benthic assemblages using Biological Traits Analysis (BTA): A study along the Emilia-Romagna coastline (Italy, North-West Adriatic Sea)*. Estuarine, Coastal and Shelf Science Volume 96, 1 January 2012, Pages 245-256. DOI: <https://doi.org/10.1016/j.ecss.2011.11.014>
- [21] Perini L., Calabrese L., Deserti M., Valentini A., Ciavola P., Armaroli C., (2011) - *Le mareggiate e gli impatti sulla costa in Emilia-Romagna 1946-2010*. Arpa Emilia-Romagna. ISBN: 88-87854-27-5
- [22] Quintiliani F., (2014) - *International Tourism in the Coastal Regions of Five Mediterranean Countries*. Tourism Analysis. Volume 14, Number 3, 2009, pp. 353-373(21). Publisher: Cognizant Communication Corporation. DOI: <https://doi.org/10.3727/108354209789705011>
- [23] Romano B., Zullo F., (2014) - *The urban transformation of Italy's Adriatic Coast Strip: fifty years of unsustainability*. Land Use Policy 38:26-36 - DOI:10.1016/j.landusepol.2013.10.001
- [24] Romano B., Marucci A., Zullo F., Fiorini L., Ciabò S., (2016) - *Urban pressure and planning management on Italian coastal areas*. In: Sixth International Symposium. Monitoring of Mediterranean Coastal Areas: problems and Measurement Techniques: Livorno (Italy) September 28-29, 2016 / edited by Claudio Conese. Firenze: Firenze University Press, 2017. (Proceedings e report; 112). <http://digital.casalini.it/9788864534282> ISBN: 978-88-6453-427-5 (print) ISBN 978-88-6453-428-2 (online).
- [25] Romano B., Zullo F., Fiorini L., Marucci A., Ciabò S., (2017) - *Land transformation of Italy due to half a century of urbanization*. Land Use Policy, 67-2017; pp.387-400 DOI:10.1016/j.landusepol.2017.06.006.
- [26] Romano B., Zullo F., Fiorini L., Romano B., (2019) - *Molecular no Smart-planning in Italy 8000 Municipalities in Action throughout the Country*. Sustainability 2019,11,6467 DOI: 10.3390/su11226467.
- [27] Sekovski I., Armaroli C., Calabrese L., Mancini F., Stecchi F., Perini L., (2015) - *Coupling scenarios of urban growth and flood hazard along the Emilia-Romagna coast (Italy)*. Natural hazards and earth system sciences, Volume 15, pp 231-2346. <http://dx.doi.org/10.5194/nhess-15-2331-2015>.
- [28] Simeoni U., Valpreda E., Corbau C., (2010) - *A National Database on Coastal Dunes: Emilia-Romagna and Southern Veneto Littorals (Italy)*. In: Green D. (eds) Coastal and Marine Geospatial Technologies. Coastal Systems and Continental Margins, vol 13. Springer, Dordrecht. DOI: https://doi.org/10.1007/978-1-4020-9720-1_9
- [29] UNEP/MAP/BP/RA (2005) - *A sustainable future for the Mediterranean*. United Nations environment programme, Mediterranean Action Plan Blue Plan Regional Activity Centre, Vallbone 2005.

SESSION

**MORPHOLOGY AND EVOLUTION
OF COASTLINES AND SEABEDS**

Chairman: Giovanni Sarti
Department of Earth Sciences
University of Pisa

MORPHOLOGY AND EVOLUTION OF COASTLINES AND SEABEDS

The session "*Morphology and evolution of coastlines and seabeds*" has faced a theme that is becoming increasingly important because coastal areas are characterized by high-anthropogenic pressure, relevant socioeconomic interests besides being very sensitive to the effect of climate changes.

The title of the session aims to underline how the coastal areas are a multifaceted system constituted by both emerged and submerged areas that are in continuous and mutual evolution.

Although the symposium starting date had unfortunately fallen during the Covid-19 emergence, several international and national researchers have brought their contributions to the session.

The issues addressed, mainly concern a series of case-histories (Italy, Spain, Turkey and Croatia) illustrating coastline changes along the time and, in some instances, their relationships with beach nourishment or coastal defenses. Studies about the influence of fluvial sedimentary supply on the offshore area and the effects of intensity water circulation in strongly anthropized areas are also presented. The acquisition of data of the scientific contributions derives from different approaches:

- i) analysis of aerial and satellite images,
- ii) laboratory analyses of samples collected in the study area,
- iii) experimental tests.

Gomes da Silva et al. show how the use of automatic co-registered Landsat and Sentinel-2 satellite images allows them to obtain accurate shoreline series in the Tordera Delta area (Spain).

A complementary approach is proposed by Pagán et al. that analyses aerial images spanning from 1956 to 2019 and reconstruct the coastal evolution along the Alicante coast (Spain) testing the impact of beach nourishment that occurred since the 1990s.

Similar is the methodological approach proposed by Kadri and Atroune to evaluate the diachronic evolution of the Bordj El Kiffane coastline (Algeria) with respect to the presence or absence of protection structures.

Piccioli-Resta et al. have utilized a remotely piloted aircraft systems (RPSA) along the Lecce coast (Italy), for the monitoring of the beach dunes and the nearby shorelines.

A similar technique was also utilized by Bedini et al., to monitoring the *Poseidonia oceanica* meadows evolution in the Follonica and Baratti gulfs (Italy). The drone-survey has evidenced the unsuitability of the coastal defenses used up now.

A direct sedimentological approach is proposed by López et al. to investigate, within three beaches located in Spain, the relationship between sediment wear and shoreline evolution through the use of the accelerated particle wear test (APW).

Pikelj and Furčić analyze several seabed samples collected in front of a coastal cliff subjected to erosional processes at the Vrgada Island, in Croatia. The data furnish new

information about the impact of cliff erosion on coastal sediments supply and on their longshore redistribution.

Di Leo et al. present a sedimentological and geochemical-based study to establish the influence of the Sarno river on the present-day sedimentation in the Naples (Italy) bay evaluating grain size, the presence of organic matter, and the pollution degree of the sediments samples collected in the offshore area of the bay.

Bulkan et al. use a stratigraphic perspective to infer the depositional coastal evolution of the Lake Bafa area (Aegean coast, Turkey), which occurred during the last 3,5 ka. Through the study of six cores, they document the succession of four phases, from the earlier marine-dominated stage to the present-day isolated lacustrine stage.

Finally, Di Natale et al. by means of the implementation of experimental tests of a three-dimensional physical model, carry out an evaluation of the intensity water circulation within marinas and defense structures located in relevant sites of Italy (Salerno and Ischitella stretch of coast along with the harbors of Fiumicino Manfredonia and Castelvoturno).

Giovanni Sarti
Department of Earth Sciences
University of Pisa
Email giovanni.sarti@unipi.it

COASTAL EROSION IN THE GULF OF FOLLONICA AND BARATTI AND COASTAL DEFENSE METHODS

Roberto Bedini¹, Paolo Colantoni², Christine Pergent-Martini³

¹Istituto di Biologia ed Ecologia Marina, Piazza G. Bovio ¾, 57025, Piombino (LI)
phone +39 0565 225196, fax +39 0565 227021, e-mail: bedini@biomare.it; museomare@biomare.it

²Istituto di Geodinamica e Sedimentologia – Università di Urbino

³Université de la Corse (FR)

Abstract – From 1988 to the present the Institute of Marine Biology and Ecology of Piombino has studied the marine environmental situation of the Gulf of Follonica (Italy), in collaboration with the Universities of Siena, Pisa, Urbino, Sassari, Corte (FR) and the CNR of Pisa. A particular attention has been given to the study of biocenoses and to the *Posidonia oceanica* (Linnaeus) Delile, 1813 meadows. In the year 2000 a cartography of the meadows of the whole Gulf was made with the changes of the profile of the coast in front of it (fig. 1).

In recent years erosion has drastically changed the sandy beaches mainly as a consequence of the constant retreat of the *P. oceanica* meadows whose possible causes have been studied. The increase of the beach was the method adopted to make the beaches usable but with temporary results.

Also in the Gulf of Baratti the methods adopted for the defense of the beach have been inadequate.



Figure 1 - Cartography of the *P. oceanica* meadows (green patch) of the Gulf of Follonica.

Introduction

To understand the origin of the erosive phenomena of the beaches of the Gulfs of Baratti and Follonica we used experienced researchers in the various areas of investigation necessary to understand the reasons of the backspace of the beaches. If you don't know what is causing the damage, you cannot repair it.

A survey of the coastal strip of the Gulf of Follonica was made by the Institute of Marine Ecology and Biology using the filming of a drone. The footage shows, if there was need for, that where the beach rocks exist the coast has endured the storms while where there are no rocks or there are breaks in the rocks erosion has changed the beach, causing it to decline (fig. 2). Flat beach-rocks perform a function similar to that of *P. oceanica* meadows: they dampen the impact force of the waves that arrive at the beach and they keep the sand removed from the beach when the waves come back.



Figure 2 - Flat beach-rocks dampen the impact force of the waves that arrive at the beach. Where there are breaks in the rocks erosion has changed the beach (yellow arrows).

Materials and Methods

The underwater shooting to map the *P. oceanica* meadows of the Gulf of Follonica was carried out by the G.A.I.T. oceanography and marine geophysics company and developed by the Geodynamic and Sedimentology Institute of the University of Urbino. Ecological data and the distance of the upper limit of the meadow from the coast line were carried out by marine biologists using transects 500 m long perpendicular to the coast line.

Attempts have been made for the dune reforestation to keep much more sand during sea storms using planting squares of fascines with plants inside to hold the sand with

the roots (fig. 3). On the beach, close to the dunes, sticks and piles of logs tied by a rope have been placed (fig. 4).

In the Gulf of Baratti sacks of geotextile cloth containing sand have been used to defend beaches from erosion (fig. 5).



Figure 3 - Protections used to improve the success of the dune reforestation.



Figure 4 - Sticks and piles of logs tied by a rope.



Figure 5 - Sacks of geotextile cloth containing sand.

Results

The results were negative for all the methodologies used in the Gulfs of Follonica (fig. 6 and 7) and Baratti (fig. 8).



Figure 6 - The planted vegetation inside the protections had completely died.



Figure 7 - The sticks and piles of logs tied by a rope were dispersed in the sea by the storms.



Figure 8 - Some sacks of geotextile cloth containing sand were completely destroyed (red arrows) by sea storms.

Discussion

The problems of the coastal erosion, and the methods used for its defense, are usually faced by engineers and geologists without the contribution of marine biologists. The extent of beach erosion problems also depends on what the waves encounter before reaching the shore such as *P. oceanica* meadows, flat beach-rocks or other types of seabed. This is the marine biologist's field of study who can make an important contribution to establish the methods of intervention. If I put in defense of a beach sacks of geotextile cloth containing sand I should know that during the storms stones or wooden logs thrown against them will destroy them.

Conclusions

Coastal erosion is a growing phenomenon in our seas often linked to anthropic activities. To fight it you need skills on what to do both on the coast and in the sea in front of it. The impact force of the waves must be dampened before it reaches the sandy beaches. The continuous retreat of *P. oceanica* meadows in front of the beaches of Baratti and the Gulf of Follonica has caused their consequent great erosion. So if we want to imitate the function of the *P. oceanica* meadows and beach rocks it is necessary to operate in the sea in front of the beach and not on it.

Acknowledgements

Thanks to Arianna Trafeli for the compilation of the research text.

References

- [1] Acunto S., Canali M.G., Bedini R., Cinelli F. (1997) - *Dinamica stagionale delle praterie di Posidonia oceanica (L.) Delile nei Golfi di Follonica e Baratti: struttura, fenologia e comunità epifita*, Ambiente Mare: Ecologia e Nuove Tecnologie Di Ricerca, Regione Toscana, collana Ricerca Scientifica e Tecnologica 12, 59-78.
- [2] Bedini R. (1995) - *L'ecosistema a Posidonia oceanica (L.) Delile come biondicatore della qualità delle acque*, Lo stato dell'Ambiente in Toscana, Edizioni Regione Toscana 4, 27-42.
- [3] Bedini R., Bedini M., Piazzini L., Bonechi L. (2016) - *Cartografia bionomica dell'area marina costiera attigua alle vasche di Colmata del Porto di Piombino*, Proceedings from Codice armonico, Sesto congresso di scienze naturali Ambiente Toscano, Castiglioncello, Italy, 13-15 October 2016, pp. 129-138.
- [4] Bedini R., Canali M.G., Baldi C. (2001) - *Prove di coltivazione in laboratorio di Posidonia oceanica (L.) Delile a partire dai semi*, Proceedings from Geoitalia 2001: 3° forum italiano di scienze della terra, Chieti, Italy, 5-8 September 2001.
- [5] Bedini R., Canali M.G., Bulleri F., Bedini A., Fantini R., Magnarini L., Franca A., Colantoni P. (2000) - *Mappatura del limite superiore di alcune praterie di Posidonia oceanica lungo la costa Toscana*, Biologia Marina Mediterranea 7 (1), 499-508.
- [6] Bedini R., Frassinetti S., Maschera M.C., Sbrilli G. (2006) - *Indagine preliminare sugli scarichi a mare del Golfo di Follonica (GR)*, Proceedings from V Convegno Nazionale CoNISMa: "Il Mare: centralità d'interessi nel XXI secolo. Capacità scientifiche italiane e risorse nel competere", Viareggio, Italy, 14 -18 November 2006.
- [7] Bedini R., Nannelli A., Battistini F. (2013) - *Restoration of Posidonia oceanica (L.) Delile meadows: is there an effective methodology?*, Journal of Life Sciences 7 (7), 722-726.
- [8] Bedini R., Nannelli A., Giachini F., Maestrini M., Boccia B. (2006) - *Indagine preliminare sulle praterie di Posidonia oceanica (L.) Delile antistanti Ansedonia e Talamone (Grosseto)*, Proceedings from Codice Armonico - Primo congresso di scienze naturali della Regione Toscana, Castiglioncello, Italy, 2006, pp. 141-144.
- [9] Bedini R., Piazzini L. (2012) - *Evaluation of the concurrent use of multiple descriptors to detect anthropogenic impacts in marine coastal systems*, Marine Biology Research 8 (2), 129-140.
- [10] Morelli D., Bedini R., Magnarini L., Fantini R., Colantoni P. (2001) - *Estensione della Posidonia oceanica (L.) Delile in alcuni tratti di litorale dell'Isola d'Elba e del Golfo di Follonica (Tirreno settentrionale)*, Proceedings from Geoitalia 2001: 3° forum italiano di scienze della terra, Chieti, Italy, 5-8 September 2001.

A SEDIMENTOLOGICAL PATTERN OF A COASTAL TRANSITIONAL ENVIRONMENT: FROM THE EASTERN MEDITERRANEAN SEA SHORELINE THROUGH THE LAKE BAFA

Özlem Bulkan^{1*}, Burak Yalamaz², M.Namık Çağatay²

¹Istanbul University-Cerrahpaşa, Geological Engineering Department, Istanbul (Turkey)

bulkan@istanbul.edu.tr

²Istanbul Technical University, Geological Engineering Department, Istanbul (Turkey)

Abstract – Lake Bafa is located in a marine to terrestrial transitional area on the coastal Aegean plain. It has been under the influence of different sedimentological systems over the last 3.5 ka, namely fluvial, delta frontal, swamp and lagoon. This study is based on the lithological study and correlation of six sediment cores (*BAF35*, - 37 - 39 - 41, - 42, - 46) distributed over the Lake Bafa basin.

Concerning the main depositional characteristics and radiocarbon chronology, we aim at reconstructing the fundamental characteristics of local abrupt and gradual environmental fluctuations in this coastal study site. The gradual changes reflect four main environmental phases: the present isolated lacustrine stage (last 0.8 ka), a lagoon stage (0.8÷1.75 ka BP), a coastal marine-fluvial interaction stage (1.75÷2.7 ka BP) and the earliest marine-dominated stage is (before 2.7 ka BP). Further sedimentological markers points to abrupt geo-events, mainly controlled by the local hydro-climate, geomorphology and geo-tectonic processes.

Introduction

Several lagoons and coastal lakes were formed on the Anatolian coastal plain of the Aegean Sea in the Eastern Mediterranean, following the Holocene transgression. Sedimentary successions of these coastal aqueous environments constitute important archives for the Holocene coastal evolution, including the sedimentological processes and geomorphological changes [1, 7].

Both an west to east directed transect from a marine to an inland and a core-depth profile in a recent lacustrine or lagoon system potentially allow us to understand the nature of the corresponding environmental and ecosystem changes in these rapidly evolving coastal aquatic systems, such as the coastal plains of the Eastern Mediterranean during the Holocene [5,7]. In this respect, we conducted a paleo-limnological study on the Lake Bafa basin, representing a current terrestrial lacustrine geo-setting (Figure 1). During the middle to late Holocene, the basin has gradually evolved geo-morphologically from an open marine gulf-estuarine environment (Aegean Sea), through a lagoon and to its current isolated lacustrine geo-setting [2-7]. Lake Bafa basin is currently classified as a completely isolated fresh lacustrine system near the present Aegean Sea coastal plain. These rapid environmental changes, which are taken place over a geologically short time scale, are mainly driven by the deltaic progradation of a dominant river system, following the early Holocene transgression (E-W trending Buyuk Menderes River) [1-3]. As such, Lake Bafa basin sedimentary

succession represents an important archive for both paleo-limnologists and paleoceanographers. Our main purpose is to reconstruct the general sedimentological pattern of lake Bafa basin, illustrating the geo-markers of the abrupt and gradual environmental changes and fluctuations occurred during the late Holocene.

Materials and Methods

Several sediment cores were retrieved along E-W and N-S transects in the lake's basin, using water-sediment interface piston and hammer-piston coring methods. The six sediment cores include *BAF35*, -37, -39, -41, -42, -46, which range in length from 1.5 m to 4.5 m long (Figure 2).

Litho-stratigraphical characterisation of the cores mainly were defined based on the macro-sedimentological properties (i.e. sediment colour, sediment size, structure and abundance and the types of the shell content).

Selected *Cerastoderma glaucum* shells were analysed in Beta Analytical Laboratories for AMS radiocarbon age determinations [6-7]. These data were calibrated to calendar ages using CALIB v.5 software [8-9], applying a reservoir age correction of 400 years.

Grain size analyses were carried out at the EMCOL Laboratories in Istanbul Technical University. Samples were treated with HCl and KOH, before the analysis. The grain size distribution of the sediment samples was determined at 5 cm resolution using sieve analysis for coarse-grained fraction ($>63\ \mu\text{m}$) and a Frisch Analysette22 laser grain size analyser for fine-grained ($<63\ \mu\text{m}$) fraction of lake sediments.

Results

This study represents the lithological characteristics of the lake Bafa sediments and overall spatial distributions, in accordance to the cross-correlation of several sediment cores *BAF35*, -37 -39 -41, -42, -46 (Figure 2). Detailed stratigraphy of *BAF37* taken from the basin centre was previously documented in several publications [4-7]. Further sedimentological characterisation of *BAF35*, -42, -46 cores and detailed litho-stratigraphy of *BAF39*, -41 cores were represented in this study for the first time (Figure 3).

In a basic frame, sedimentary succession of the different cores reflects similar lithological characteristics (Figure 3). The topmost unit of the cores consists mainly of homogeneous clayey silt deposited in the last 1.0 ka BP. A laminated sediment unit was deposited during 1 to 1.5 ka BP time interval. The laminated unit is followed downwards by a mainly homogeneous to thickly banded sediment unit accumulated from 1.5 to 2.2 ka BP. The oldest sediments investigated in this study consist of laminated clay to sand layers, which accumulated approximately during 2.3 to 3.5 ka BP period. The depositional system characteristics of these individual sedimentological units were classified basically as the current lacustrine stage (S-I: last 0.8 ka), lagoon-dominated stage (S-II: 0.8–1.75 ka BP), marine-river interaction stage (S-III: 1.75–2.7 ka BP) and marine-dominated stage (S-IV: earlier than 2.7 ka BP), as discussed below [6-7].

Moreover, the variable sedimentation rates were observed in cores located in different parts of the basin. Higher sedimentation rates were observed in cores from the basin

depo-centre and in north-western parts of the lake's basin compared to those in the cores taken from the eastern parts of the basin, particularly for the lacustrine-lagoonal phase.

Detailed grain size distributions were illustrated through the *BAF46* core (Figure 3). Furthermore, the represented time interval extended along with the lowermost units of the core *BAF37*, exhibiting the additional older layers. *BAF46* sediments consist of clay in a ratio between 0 % to 40 %, sand in a ratio between 0 % to 20 % and an average of 60 % silt. General fluctuations of the grain size distribution of sediments collected from the various cores reflect similar tendencies through the depth profile. Hence, a similar shift through the enhanced clay-sized material was observed in the 55-110 cm depth of the *BAF35* core, 120÷140 cm depth of the core *BAF37* and 90÷120 cm depths of the core *BAF46*. Similarly, an increase of the relative contribution of the sand-size grains was either observed in 10÷60 cm and 110÷230 cm depths of the core *BAF35* and 20÷80 cm and 140÷220 cm depths of the core *BAF37*.

Discussions

The main sedimentology of various cores exhibits similar lithological properties. However, the correlated lithological succession of cores *BAF39*, -41, -42 recovered along the east-west transect indicates distinct changes in the sedimentary facies of the neighbouring geological sub-settings (i.e. marine, fluvial, etc) and in the proportion of the endogenic material during the marine, lagoon, lacustrine stages. The gradual transition from –coastal marine to lagoonal and lacustrine facies were observed in the eastern parts of the lake basin (in the depositional boundary of the S-I-II-III versus S-IV stages). Hence, the gradually reduced amounts of the lacustrine and lagoon originated sediment deposition was observed through the eastern parts of the lake basin, during the last 1.75 ka. The cores taken from the easternmost parts of the lake's basin include the most distinct evidence of marine sedimentation compared to the cores taken from the western-central parts (Figure 3). These spatial variations potentially either caused by the material supply amount from the neighbouring geological sub-settings (i.e. marine, fluvial) or variations of spatial boundaries of the primary depositional sub-basins (i.e. marine, lagoon, lacustrine stages).

Cross-correlation of the cores reflects a sum of the characteristic properties of paleo-environmental stages (I) or geological events (II).

(I) Lithological characteristics of the environmental stages from past to recent term are summarized as followingly: (1) the older marine sediments were observed either as grey coloured well-washed sands or massive sand deposits intensively rich in marine shell residues; (2) the transition from a lagoon to the lacustrine environment is characterized by a characteristic thin unit with laminated or varved layers; (3) flood events particularly occurred in the marine-river interaction stage, reflect beige coloured massive sand size depositional pattern; (4) Lacustrine stage reflects mostly massive clay-silt size in lithology.

(II) A sum of continuous signals of the coarse event deposits was also detected along with the north-south transect, considering the lithological indicators and grain size distribution data. The normal sedimentary succession in the cores (in particular core *BAF46*), with its different facies, is interrupted by two types of event deposits in the form of coarse (sandy) grained sedimentary units or sand-clay intercalations.

The first type of event deposits become especially frequent during the last 2.5 ka years. These units are half to few cm thick and are characterized by coarse detrital fraction intercalated

with clays. These event deposits reflect mass flow characteristics considering the lithological indicators, grain size distribution data and their continuous signals along with the north-south sedimentary profile (i.e. 3÷10 cm; 43÷50 cm; 150÷160 cm; 190÷205 cm; 227÷234 cm depths of for *BAF37* core and 10÷20 cm; 85÷92 cm; 243÷252 cm, 290÷300 cm and 357÷370 cm depths of *BAF35* core). The respective age determination of these event sediments reflects a positive correlation with the geological dates of the significant local ancient earthquake events, occurred during the last 2.5 ka years. The respective dates for these ancient earthquakes are 1955 Soke, 399 AD Izmir, 468 AD Aydın, 68 BC Millet, 350 BC Priene. Therefore, we suggest classifying these mass flow units as seismo-turbidite layers (Figure 3).

The second type of event deposits is massive sandy layers, which particularly observed in the *BAF46* core. The radiocarbon ages of these layers are not correlated with historical earthquake records. Only other possible origins for this rapid deposition of these coarse units are the storm surges and floods. Based on their highly variable grain-size distribution characteristics and cyclic pattern over time, we tentatively suggest that a high number of these layers represent paleo-flood deposits of the Buyuk Menderes River in the basin. These interpretations are also supported by the palaeontological and geochemical data of our previous studies on *BAF37* core [6-7].

Conclusion

We applied an integrated method, useful for investigation of the complete nature of various coastal environments, simply focusing the litho-facies analysis, together with radiocarbon chronology, in a transitional marine-terrestrial setting on the Anatolian coastal plain of the Aegean Sea. The results show that the coastal geomorphological evolution of the area is controlled mainly by the interactions of the Holocene marine transgression and progradation of riverine sediments. Following the Holocene marine transgression, the prograding deltaic sediments started filling a marine gulf and gradually isolating part of it to form first a lagoon, and then, with complete isolation, form the present Lake Bafa over the last 3.5 ka. In particular, during sedimentary unit the river-marine interaction stage, the lagoon was frequently flooded by the river depositing coarse event deposits, which interrupt the normal sedimentary succession.

The synthesis of the main characteristic environmental phases and geo-events would be summarized as followingly: (1) low energy conditions related homogenous fine-grained material deposition, (2) abrupt geological events related coarse-grained sediment accumulation in massive layers and (3) mass flow pattern of sediment accumulation.

Acknowledgments

The scientific and technological research council of Turkey (Tubitak-Ardeb, Project numbers: 113Y070; 115Y766) and scientific research projects coordination unit of Istanbul University (İ.Ü.BAP Project numbers: 28942; 17828) kindly provided financial research supports, which is gratefully acknowledged. We would kindly thank to Istanbul Technical University Eastern Mediterranean Centre for Oceanography and Limnology, its students and particularly Dursun Acar for their contribution for retrieving the sediment cores.

Figures



Figure 1 - Geographical location of the Lake Bafa Basin (*google earth image*).



Figure 2 - L1-L39 indicate core locations (sediment-water interface short cores and upto 4.5m depth long piston sediment cores) of the entire project (I.U.BAP Project numbers: 28942; 17828) and studied cores *BAF35*, -37, -39 -41, -42, -46.

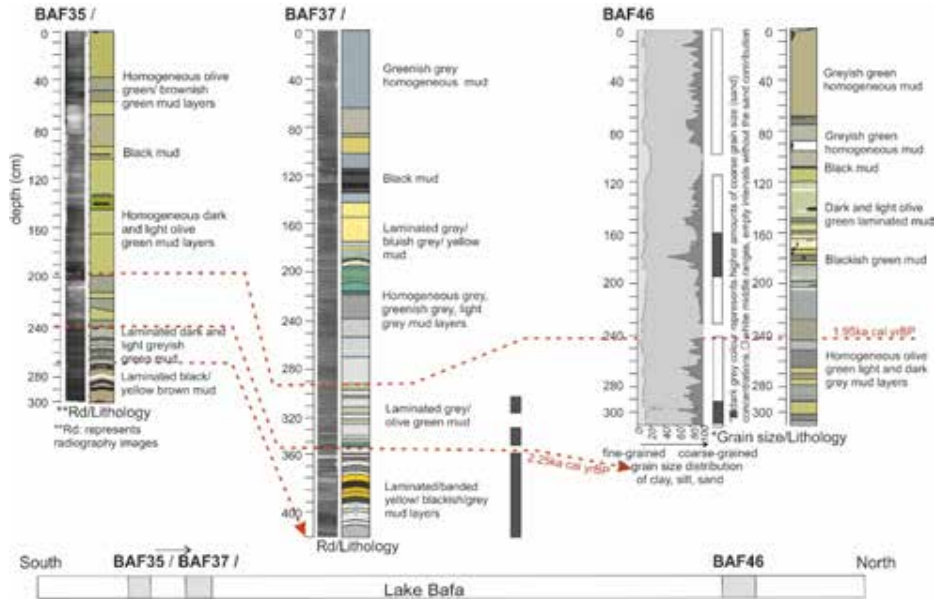

Figure 3 - Litho-stratigraphic correlation of studied cores *BAF35*, - *37*, -*46* and the detailed grain size distribution of core *BAF 46*. Detailed lithology and age determinations previously published for the core *BAF37* [6-7].

References

- [1] Hakyemez, H.Y., Tevfik, E., Göktaş, F. (1999) - *Late Quaternary evolution of the Gediz and Büyük Menderes grabens, Western Anatolia, Turkey*. Quaternary Science Reviews 18, 549 - 554.
- [2] Brückner H., Müllenhoff, M., Handl, M., van der Borg, K. (2002) - *Holocene landscape evolution of the Büyük Menderes alluvial plain in the environs of Myous and Priene (Western Anatolia, Turkey)*, Z. Geomorphol. 127, 47 - 65.
- [3] Knipping, M., Müllenhoff, M., Brückner, H. (2008) - *Human induced landscape changes around Lake Bafa (Western Turkey)*. Veget. Hist. Archaeobot. 17, 365 - 380.
- [4] Bulkan Ö., Yalamaz B., Çağatay, M.N., (2014) - *The effect of surrounding physical processes on depositional environment of the Lake Bafa (Western Anatolia), during the last 2500 years*, Proceedings of the 19th International Sedimentology Congress, Geneva, Switzerland, 18-22 August 2014 volume 1, pp. 104.
- [5] Bulkan Ö., Zhu X., Wei W., Yalamaz B., Çağatay, M.N. (2017) - *Organic Geochemical Characterisation of the Lake Bafa Sediments, Accumulated during the last 4500 years, Western Turkey*, Proceedings of the 28th International Meeting on Organic Geochemistry, Florence, Italy 17-22 September 2017.
- [6] Bulkan, Ö., Sancar Ü., Çağatay M., Zhu X., Wei W. (2019) - *Water Column Chemistry of Late Holocene Lake Bafa, Eastern Coast of the Aegean Sea (Turkey)*, in Patterns

- and Mechanisms of Climate, Paleoclimate and Paleoenvironmental Changes from Low-latitude Regions, *Advances in Science, Technology & Innovation*, ed. Zhang, Z., Khélifi, N., Mezghani, A., Heggy, E., ed. Springer, 7, 65 - 67.
- [7] Bulkan Ö., Toksoy Ediş B., Çağatay M. (2019) - *Geo-archives of a Coastal Lacustrine Eco-system: Lake Bafa (Mediterranean Sea)*, In: *Sedimentary Processes Examples from Asia, Turkey and Nigeria*, ed. (by Gemma Aiello) Intech Open, London, 29-49.
- [8] Reimer, P.J., Baillie, M.G.L., Bard, E., Bayliss, A., Beck, J.W., Bertrand, C., Blackwell, P.G., Buck, C.E., Burr, G., Cutler, K.B., Damon, P.E., Edwards, R.L., Fairbanks, R.G., Friedrich, M., Guilderson, T.P., Hughen, K.A., Kromer, B., McCormac, F.G., Manning, S., Bronk Ramsey, C., Reimer, R. W., Remmele, S., Southon, J. R., Stuiver, M., Talamo, S., Taylor, F., Weyhenmeyer, C.E., (2004) - *INTCAL04 terrestrial radiocarbon age calibration, 0-26 cal kyr BP*. *Radiocarbon* 46, 1029 - 1058.
- [9] Stuiver, M., Reimer, P.J., and Reimer, R.W., (2005) *CALIB 5.0*. (program and documentation at <http://calib.qub.ac.uk/calib>).

THE OFFSHORE ENVIRONMENTAL IMPACT BY SARNO RIVER IN NAPLES BAY (SOUTH-WEST ITALY)

A. Di Leo¹, S. Giandomenico¹, L. Spada¹, N. Cardellicchio¹, F. P. Buonocunto²,
E. Esposito², L. Ferraro², L. Giordano², A. Milia², C. Violante²

¹Water Research Institute - Consiglio Nazionale delle Ricerche, Taranto, Italy
antonella.dileo@cnr.it, +39-099 4542 207 - fax: +39-099-4542215

²Institute of Marine Sciences - Consiglio Nazionale delle Ricerche, Naples, Italy
francescopaolo.buonocunto@cnr.it, +39-081 5423828 – fax: +39-081 5423888

Abstract – The Sarno River Basin (South-west Italy) is one of the most polluted river basins in Europe due to widespread industrialization and intensive agriculture. From the geological point of view, it lies between the Somma-Vesuvius volcanic complex and the limestone formations of the Campania-Apennine Chain. The goal of this work has been to establish the influence of the Sarno river on the present sedimentation in the Naples bay continental shelf by evaluating organic matter contribution and pollution. Sediments samples were collected, by van Veen grab, in 71 stations located offshore the Sarno river between Vesuvian and Sorrento Peninsula coasts. The characteristics of the surface sediments were analysed to highlight spatial trends in the (i) granulometry (grain-size); (ii) total nitrogen, organic carbon and total phosphorus; (iii) metal content (Hg, Cd, Pb, As, Cr, Cu, Ni, Zn, Fe and Mn).

The sediment distribution suggested that sediments from the Sarno River prevailed in the central part of the bay between the sand grained deposits from Vesuvius and coarser grained sediments from Sorrento Peninsula. The Sarno River deposition is characterized by silt/clays rich in organic elements with a high water content. A comparison with a previous study carried out onshore in the Sarno river basin has allowed to interpret the elevated Pb, Zn, Cd, and Hg concentrations most likely related to geological and anthropogenic sources, to underlying volcanic rocks, and contamination from fossil fuel combustion associated with nearby urban centres. In particular, as verified onshore, Ni and Cr contamination is most likely originating from anthropogenic sources as the Solofra tannery industry; the results suggest as these metals have been dispersed offshore. All these elements permit to identify the distribution of the present Sarno prodelta and to identify the influence of the onshore anthropogenic pollution in the adjacent submarine area.

First results from this study highlight the influence of the Sarno prodelta in Naples Bay and represent the first step in the characterization of a marine area strongly influenced by a very high populated and touristic coast. Therefore, the study represents a data base for the offshore environmental impact evaluation.

Introduction

Metal contamination in sediment and water is one of the largest threats to the environment. It is well documented that sediments play a key role in the sorption and transport of trace metals in aquatic environments. More than 97 % of the mass transport of

heavy metals to the oceans is associated with river sediments [Jain and Sharma, 2001]. Trace metals tend to be adsorbed onto the suspended particles after entering into the aquatic systems, whereas > 90 % of trace metals are bound to suspended solids and sediments, leading to their significant accumulation and enrichment in sediment in aquatic systems [Wei et al., 2016]. The metals adsorbed in this way are not stable and unchanging. They can go through a series of physical, chemical, and biological processes and be released as the metals adsorbed of aquatic environments [Gaur et al., 2005]. Under variable hydraulic conditions and through various remobilization processes some sediment bound metals might be released again into the water body [Jahan and Strezov, 2018]. Various studies have demonstrated that marine sediments from industrialized coastal areas are greatly contaminated by heavy metals; therefore, the evaluation of metal distribution in surface sediments is useful to assess pollution in the marine environment.

The Gulf of Naples is an area where sediments have different geochemical composition: metal concentrations vary according to the different geologic substrate and different inputs from the coastal environment. The main geologic features of the Campania Margin are represented by an elongated mountain ridges bounded by normal faults that affected the older Apennine thrust belt [Milia et al., 2017]. The ridges are made up of Meso-Cenozoic calcareous rocks and locally by Miocene clastic deposits. One of this is the Sorrento Peninsula-Capri Island ridge, oriented ENE-WSW, that bound the Bay of Naples southward. Recently, over the last 400 ky, several volcanic eruptions affect the area which deposits as the Pyroclastic deposits of Campania Ignimbrites and the pyroclastic deposits, lavas and fall deposits of the Vesuvius and Campi Flegrei cover largely the Campania Plain and the Naples Bay [Torrente et al. 2010; Milia and Torrente, 2012]. An alluvial plain is present between the Vesuvius and the carbonatic ridge corresponding to the Sarno Plain where a river catchment draining toward the Naples Bay. The Sarno river hydrographic basin cover an area of approximately 500 km².

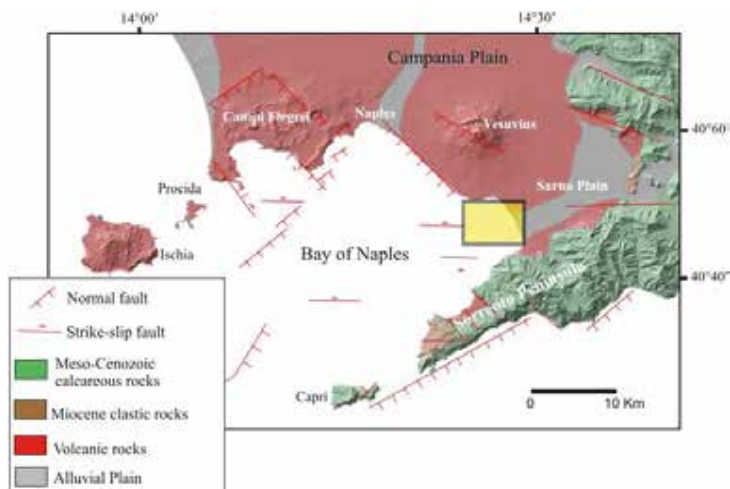

Figure 1 - Geological sketch of the Campania margin. The yellow rectangle corresponds to the study area.

The adjacent Campania Plain is characterized by high density population and in particular the Sarno Plain is one of the most polluted area in Europe due to widespread industrialization and intensive agriculture. The goal of this work has been to establish the influence of the Sarno river on the present sedimentation in the Naples bay continental shelf by evaluating organic matter contribution and pollution. Sediments samples were collected in 71 stations located offshore the Sarno river between Vesuvian and Sorrento Peninsula coasts. The characteristics of the surface sediments were analysed to highlight spatial trends in the (i) granulometry (grain-size); (ii) total nitrogen, total organic carbon and total phosphorus; (iii) metal content (Hg, Cd, Pb, As, Cr, Cu, Ni, Zn, Fe and Mn).

Materials and Methods

Surface sediments samples were collected by Van Veen grab (25 L) in 71 sites located offshore the Sarno river between Vesuvian and Sorrento Peninsula coasts (Figure 1). After sampling, sediments were stored in clean polyethylene bags and frozen at -20 °C until analysis. The sediment stations were distributed from 5 meter to about 100 meter of water depth on the continental shelf. Samples for grain size analysis were treated with H₂O₂ solution, then washed and dried at 40 °C. Grain size analyses were performed following the ICRAM “*Metodologie analitiche di riferimento*” (2003). The coarse fraction (> 63 µm) was sieved using ASTM series sieves, while the fine fraction (< 63 µm) was analysed by means of laser diffraction granulometer (Laser Particle-Size Analyzer). The Wentworth grain size classification was used as reported in Table 1.

Table 1 - Wentworth grain-size scale.

Gravel > 2 mm
Sand 2 mm > x > 0.063 mm
Silt 0.063 mm > x > 0.004 mm
Clay < 0.004 mm

Total organic carbon (TOC) and total nitrogen in samples sediment were determined using the technical reported in “*Metodologie Analitiche di Riferimento*” [ICRAM, 2001]. Total phosphorus content was determined following APAT IRSA-CNR 4110 (2003) method. For metal analysis the sediment samples were digested using a microwave assisted acid digestion procedure. Briefly, three replicates of 0.25 g dried sediment sample were digested with 9 mL of nitric acid, 2 mL of hydrochloric acid and 3 mL of hydrofluoric acid [SW-846 EPA Method 3052, 1996] using a MARSX microwave oven (CEM Corporation, Matthews, NC). For each digestion program, a blank sample was prepared with the same amount of acids. After digestion, 20 mL of saturated solution of boric acid was added to samples in order to delete excess of hydrofluoric acid. Each sample was diluted to 50 mL

with ultra pure water (conductivity $<0.1 \mu\text{S}$, obtained from a MILLI-QR system, Millipore, Bedford, MA, USA) and analyzed. All reagents were of analytical grade and contained very low concentrations of trace metals. Normal precautions for trace metal analysis were observed throughout. Nitric acid (70 % w/w), hydrochloric acid (37 % w/w), hydrofluoric acid (48 % w/w) and boric acid were ULTREXR II Ultra-pure Reagent (J.T. Baker, Phillipsburg, USA). Metal concentrations (Hg, Cd, Pb, As, Cr, Cu, Ni, Zn, Fe and Mn) were determined by ICP-MS, using a Perkin Elmer-model Elan 6100 DRC Plus (PerkinElmer, Norwalk, CT, USA). Each sample was analyzed for three replicates (RSD $<5\%$). Accuracy was verified using the certified reference marine sediment IAEA-356. The recovery percentage for IAEA-356 was in the range between 95 % (Pb^{208}) and 105 % (Zn^{66}).

Results

The spatial distribution of total organic carbon (TOC) in sediment samples (Fig. 2) was very different and depending on the sampling area. In particular, a high TOC value is present in correspondence of the Sarno prodelta (between stations 15 and 45). As regards total nitrogen and total phosphorus values are in most cases below the detection limit. The grain size of the sediments (Fig. 3) remains almost constant and they are constituted from: medium/fine to very fine sand, to silty up to the isobaths of 17 meters; weakly clayey silt to silty with clayey sand between the isobaths of 17 and 25 meters. Moreover, the sediment is mainly represented by sandy coarse silt to clayey with delimited areas where the sandy component prevails on the silty part. The sands consist mostly of volcano-clasts, litoclasts and bioclasts. The metal concentrations of the surface sediments exhibited clear spatial variations (Fig. 4). The Cd, As, Ni, Fe and Mn concentrations decreased gradually with distance from the shore, while Pb, Cr, Cu and Zn increased in correspondence with the Sarno prodelta (between stations 15 and 45).

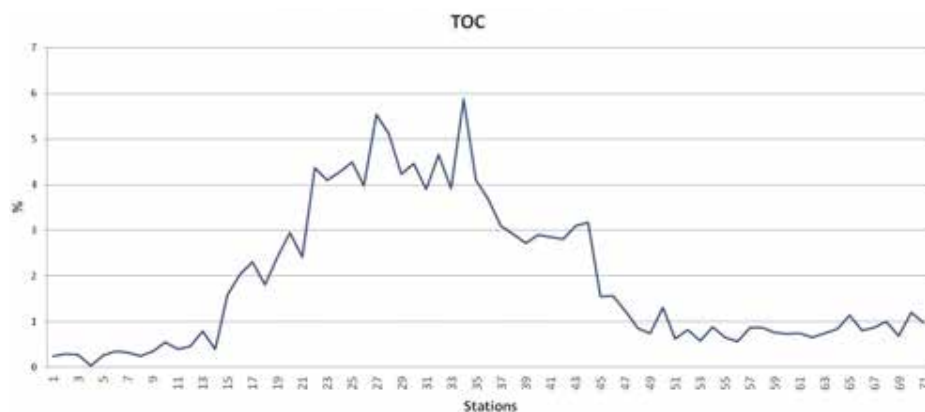

Figure 2 - Distribution of TOC in sediments.



Figure 3 - Distribution of grain size in sediments.

Discussion

Metals through human activities such as industrial wastewater processing and discharge fossil fuel use, pesticide and fertilizer application, and household waste disposal enter water bodies and accumulate in sediment [Han et al., 2016]. Besides, also the erosion and weathering of rock minerals contribute to metal levels in water bodies [Sun et al., 2018]. In particular, the Sarno Plain is one of the most polluted area in Europe due to widespread industrialization and intensive agriculture. Water from the Sarno River is heavily contaminated by the discharge of human and industrial wastes [Albanese et al., 2010; Arienzo et al., 2017]. The Gulf of Naples are the receiving environment for persistent toxic substances from the Campania Plain. The variations of metal concentrations in sediments can result from differences in the grain size, the mineralogy, organic matter and the redox of the sediment [Nabavi et al., 2013]. Metal concentrations obtained in this study were further comparable to or higher than that reported from other polluted harbours of the Mediterranean area. In particular, Cd, Cu, Mn, Pb and Zn levels were higher to those reported in the Taranto Gulf, Italy [Cardellicchio et al., 2009]. In relation to the spatial distribution the Cd, As, Ni, Fe and Mn concentrations decreased gradually with distance from the shore, while Pb, Cr, Cu and Zn increased in correspondence with the Sarno prodelta (between stations 15 and 45). A similar spatial distribution was observed for the TOC, silt and clay.

There were two areas of higher concentration: the area proximal to the coast (area between stations 1 and 14) and the area of the Sarno prodelta. This could be probably due to high concentration of industrial and urban wastes in the onshore counterpart of the study area.

However, the major factors controlling heavy metal distribution are their source, hydrodynamic conditions, sediment properties, adsorption and flocculation by fine particulate matter, and adsorption and desorption characteristics [Hosono et al., 2011].

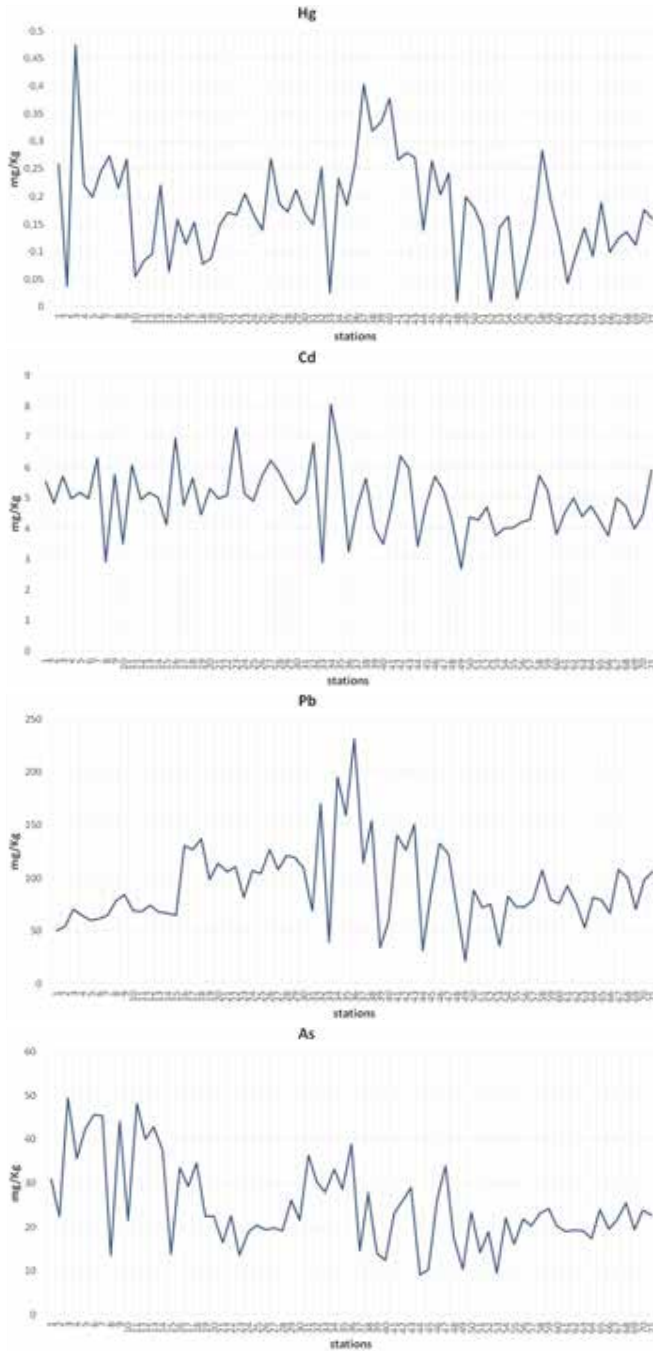

Figure 4 - *continued*

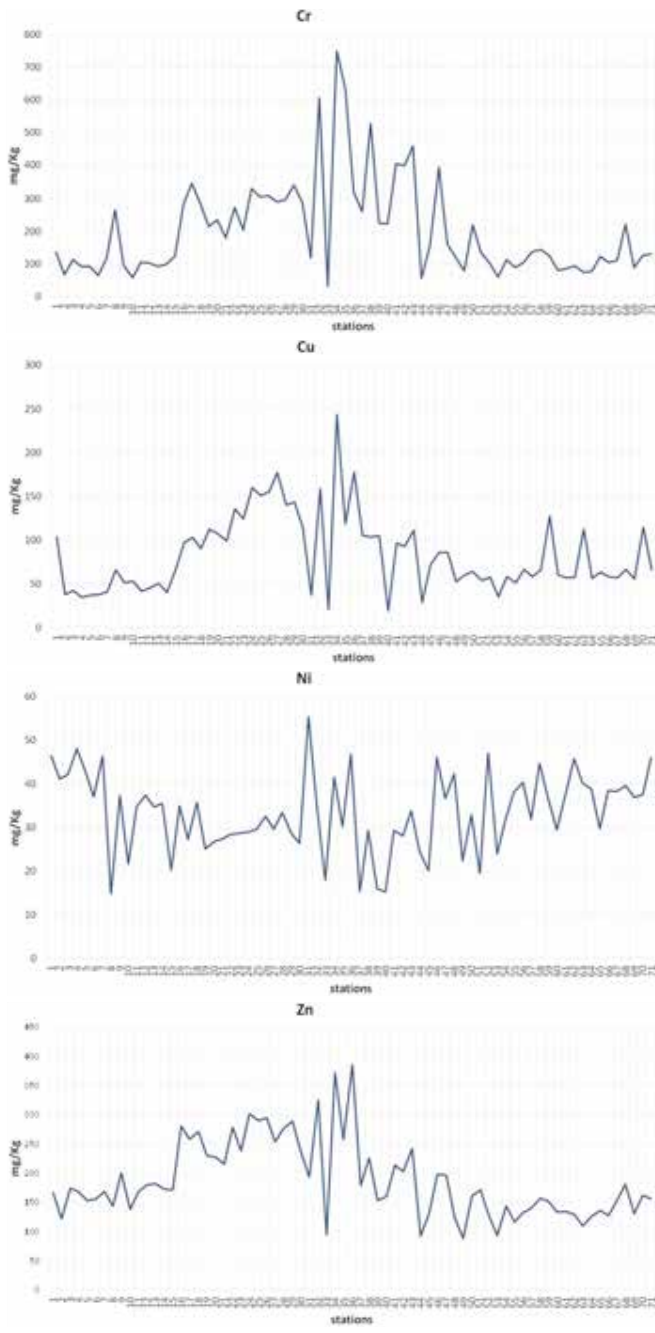

Figure 4 - *continued*

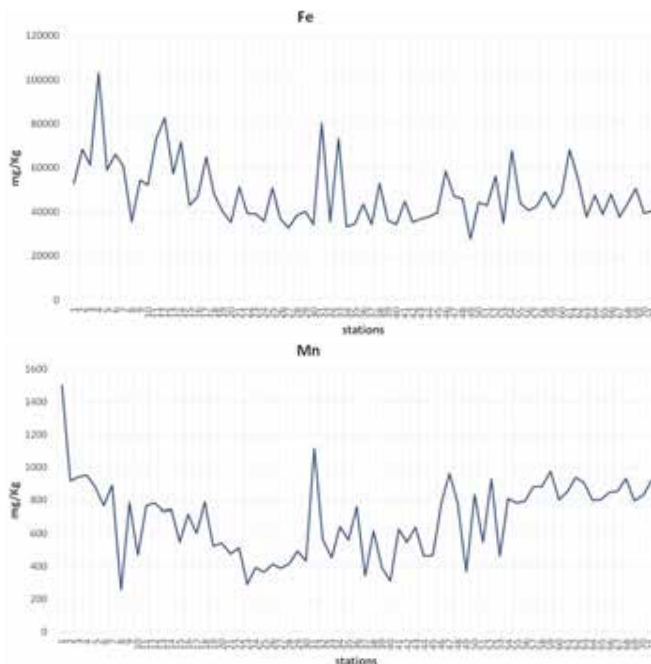

Figure 4 - Distribution of Hg, Cd, Pb, As, Cr, Cu, Ni, Zn, Fe and Mn in sediments.

Inshore, where pH and salinity were appropriate, organic flocculants and iron (Fe) and manganese (Mn) oxides coagulated the fastest, which expedited the deposition of metals in sediments. Similarly, under oxidized conditions, metals in oxidizable fraction can also be re-released during the oxygenation of organic substances and/or sulphides, and retained by Fe/Mn oxides.

Principal component analysis allowed us to clearly discriminate three areas mainly affected by heavy metals contamination and influenced by different sources related to industrial, commercial and/or urban activities. Especially the stations 1-14 near coast, characterized by sandy sediment with a pollution pattern dominated by Fe, Mn, As and Ni, while the stations 15-45 are characterized by silty sediment with a high severe pollution pattern dominated by Cu, Pb, Cr and Zn. These sites last are controlled by high level of TOC. Lastly the stations 46-71 are characterized by coarse sediment with a pollution patterns mainly dominated by Cd and Hg.

Conclusion

This study allowed us to determine the spatial distribution of metals and TOC in sediments located offshore the Sarno river between Vesuvian and Sorrento Peninsula coasts. In addition, it was possible to assess how organic matter and grain size could

influence the distribution of metals in sediments. In general, distribution show accumulation areas especially close to the coasts and in correspondence with the Sarno prodelta.

References

- [1] Albanese, S., De Vivo, B., Lima, A., Cicchella, D., Civitillo, D., Cosenza, A. (2010). *Geochemical baselines and risk assessment of the Bagnoli brownfield site coastal sea sediments (Naples, Italy)*. J. Geochem. Explor. 105, 19-33.
- [2] APAT IRSA-CNR (2003). *Metodi analitici per le acque. Metodo spettrofotometrico al blu di molibdeno (metodo 4110)*. Manuali e Linee Guida 29, volume secondo edito dal Poligrafico dello Stato.
- [3] Arienzo, M., Donadio, C., Mangoni, O., Bolinesi, F., Stanislaio, C., Trifuoggi, M., Toscanesi, M., Di Natale, G., Ferrara, L. (2017). *Characterization and source apportionment of polycyclic aromatic hydrocarbons (pahs) in the sediments of gulf of Pozzuoli (Campania, Italy)*. Mar. Pollut. Bull. 124 (2017) 480-487.
- [4] Cardellicchio, N., Buccolieri, A., Di Leo, A., Librando, V., Minniti, Z., Spada, L. (2009). *Methodological approach for metal pollution evaluation in sediments collected from the Taranto Gulf*. Toxicol. Environ. Chem. 91:1273-1290.
- [5] EPA. 1996b. "Method 3052. Microwave Assisted Digestion of Siliceous and Organically Based Matrices." Revision 0 (December 1996)." In *Test Methods for Evaluating Solid Wastes: Physical/Chemical Methods*, EPA SW-846, Third Ed., Vol. I, Section A, Chapter 3 (Inorganic Analytes), pp. 3052-1–3052-20, U.S. Environmental Protection Agency, Office of Solid Waste and Emergency Response, Washington, D.C.
- [6] Gaur, V.K., Gupta S.K., Pandey S.D., Gopal K., Misra V. (2005). *Distribution of heavy metals in sediment and water of river Gomti*. Environ. Monit. Assess. 102, 419-433.
- [7] Han, D., Currell, M.J., Cao, G. (2016). *Deep challenges for China's war on water pollution*. Environ. Pollut. 218, 1222–1233.
- [8] Hosono, T., Su, C.C., Delinom, R., Umezawa, Y., Toyota, T., Kaneko, S., Taniguchi, M. (2011). *Decline in heavy metal contamination in marine sediments in Jakarta Bay, Indonesia due to increasing environmental regulations*. Estuar Coast Shelf S. 92, 297–306.
- [9] ICRAM (2003). *Metodologie Analitiche di Riferimento del Programma di Riferimento per il controllo dell'ambiente marino costiero (triennio 2001-2003)*.
- [10] Jain, C.K., Sharma, C.K. (2001) - *Distribution of trace metals in the Hindon river system, India*. J. Hydrol. 253, 81-90.
- [11] Jahan, S., Strezov, V. 2018. *Comparison of pollution indices for the assessment of heavy metals in the sediments of seaports of NSW, Australia*. Mar. Pollut. Bull. 128, 295-306.
- [12] Milia, A., Torrente, M.M., Bellucci, F. (2012). *A possible link between faulting, cryptodomes and lateral collapses at Vesuvius Volcano (Italy)*. Glob. Planet. Change. 90-91, 121-134.
- [13] Milia, A., Iannace, P., Tesauro, M., Torrente, M.M. (2017). *Upper plate deformation as marker for the Northern STEP fault of the Ionian slab (Tyrrhenian Sea, central Mediterranean)*. Tectonophysics 710–711, 127–148

- [14] Nabavi, S.M.B., Parsa, Y., Hosseini, M., Nabavi, S.N. (2013). *Assessment of heavy metal concentration (Fe, Ni, Cu and Hg) in sediment from north of Persian Gulf. Mahshahr Coast.* World Appl Sci J. 28, 718–721.
- [15] Sun, Z.H., Xie, X.D., Wang, P., Hu, Y.N., Cheng, H.F. (2018). *Heavy metal pollution caused by small-scale metal ore mining activities: a case study from a polymetallic mine in South China.* Sci. Total Environ. 639, 217–227.
- [16] Torrente, M.M., Milia, A., Bellucci, F., Rolandi, G. (2010). *Extensional tectonics in the Campania Volcanic Zone (eastern Tyrrhenian Sea, Italy): new insights into relationship between faulting and ignimbrite eruptions.* Boll. Soc. geol. ital., 129, 297–315, doi:10.3301/IJG.2010.07.
- [17] Wei X., Han L., Gao B., Zhou H., Lu J., Wan X. (2016). *Distribution, bioavailability, and potential risk assessment of the metals in tributary sediments of Three Gorges Reservoir: the impact of water impoundment.* Ecol. Indic. 61, 667-675.

WATER CIRCULATION IN COASTAL MARINE AREAS - CASE STUDIES

Michele Di Natale¹, Stefania Di Ronza¹, Caterina Eramo¹

¹ Università degli Studi della Campania "Luigi Vanvitelli", Dipartimento di Ingegneria,
via Roma 9 – 81031 Aversa (Italy),

phone +39 081 5010386, fax +39 081 5010290, e-mail: caterina.erao@unicampania.it

Abstract – Taking into account the difficulty of water circulation within the marinas and over the defence works, an integration to the enquiries to support the technical solutions found is required, by means of the implementation of experimental tests of a three-dimensional physical model. The aim of the experimental survey carried out in the wave system basin of the University of Campania "Luigi Vanvitelli" was that of assessing the water circulation intensity behind the works of Salerno and Ischitella coast and inside Fiumicino port, Manfredonia port and Castelvoturno port. Due to the remarkable linear development of the works, their behavior was studied through the realization of a Froude scale model. The water circulation over the defense works was evaluated with reference to the storms, while inside marina with reference to the action of the jet mixers. The results of tests show that water circulation is ensured by jet mixer inside marina and by storms behind defence works.

Introduction

The presence of pollutants (hydrocarbons, oils, floating solids, organic substances, etc.) in coastal marine areas is an environmental problem that must be properly studied, both in the design phase and in the management program of the sea defence works [8]. Therefore, it is necessary to verify that there are exchange water volumes through the presence of a motion field with appropriate characteristics. In most cases, the water exchange is ensured by natural actions and, in particular, by the tidal currents.

The most frequent cases to analyse are represented by the port basins and by the basins over the coastal defence works. In the case of port basins, due to the complex geometry of the port and to small amplitude of the tidal wave, the natural circulation is ensured only for the most external areas of the port. So it is required the use of a forced circulation system using electromechanical equipment (submerged pumps and mixers) with suitable characteristics positioned inside the basin.

Emerged coastal defence works although guarantee a greater dissipation of the incident wave energy in the presence of storms, it can determine, in all the other weather conditions, a mitigation of natural water circulation with stagnation phenomena. To mitigate this condition are often realized submerged structures that guarantee adequate circulation within the protected basin and therefore adequate water quality even if it is necessary to verify its effectiveness in terms of coastal defence.

Therefore, for the above cases an integration to the enquiries to support the technical solutions found is required, by means of the experimental tests on a three-dimensional physical model.

In this paper, we report the results of some experimental studies performed using the wave tank of the Maritime Hydraulics Laboratory of the University of Campania "Luigi Vanvitelli" [2]. The wave basin is 15.70 m wide and 12.45 m long and has an operating water depth, h equal to 0.56 m, kept constant for all the tests. The concrete bed slope is fixed at 1:20 for 10 m length. The bed in the basin is formed by sorted well sand with $D_{50}=0.20$ mm and $\gamma_s=2.60$ t/m³. Waves are generated by 30 piston type wave paddles that are capable of generating regular and irregular waves with several wave attack angles.

In particular, the studies carried out for the evaluation of water circulation will be described under the action of forced circulation system positioned in the basins of the new tourist ports of Manfredonia, Castel Volturno and Fiumicino; similarly the solutions analysed for the water circulation evaluation over of the Salerno and Ischitella defence works will be examined.

Experimental tests were conducted on Froude models [1;7]. The water circulation was evaluated over the defence works with reference to the storms, while inside marinas with reference to the action of the jet mixers. For each test performed, the water circulation analysis was done using velocimeter and colourful floating particle, which allowed verifying the technical solution efficacy with a qualitative-quantitative approach. Figures 1 and 2 show the scheme of the two cases studied.

Experimental Setup

The wave basin is 15.70 m wide and 12.45 m long. The operating water depth, h , ranges from 0.40 m to 0.60 m. The fixed concrete bed slope is 1:20 for a 10 m length. The bottom material in the basin is formed by well-sorted sand with $D_{50}=0.20$ mm and $\gamma_s=2600$ kg/m³ (Figure 1).

A wave-generator with a non-reflective generation system is used to produce right angle and oblique incident waves using a snake-front piston-type paddle system that has 30 wave-paddles and actuators. Wave absorbers are used to reduce the waves reflected from the side and rear walls of the wave basin. A wave-absorbing beach is used to reduce the wave energy on the shore side. The wave generation software used for controlling the paddle system is AWASYS, developed by Coastal Engineering Laboratory of University of Aalborg. The absorbing wave system is operated by non-recursive linear digital filters working in real time [6]. In particular, the values of wave height are between 0.015 m and 0.25 m, the wave periods between 0.6 s and 2.0 s for water level varying 0.40 m and 0.60 m. The wave propagation angles vary between 0° and 30° with directional spreading, s , between 0–40. Wave heights are measured by 30 resistance probes with a sampling rate of 20 Hz. Measurements of beach profiles and bathymetric profiles are made with a Conventional Profiler M5L Laser setting on the carriage (Figure 1 [6]). Flow field measurements are carried out by an ultrasonic Doppler Velocimeter with a sampling frequency equal to 20 Hz.

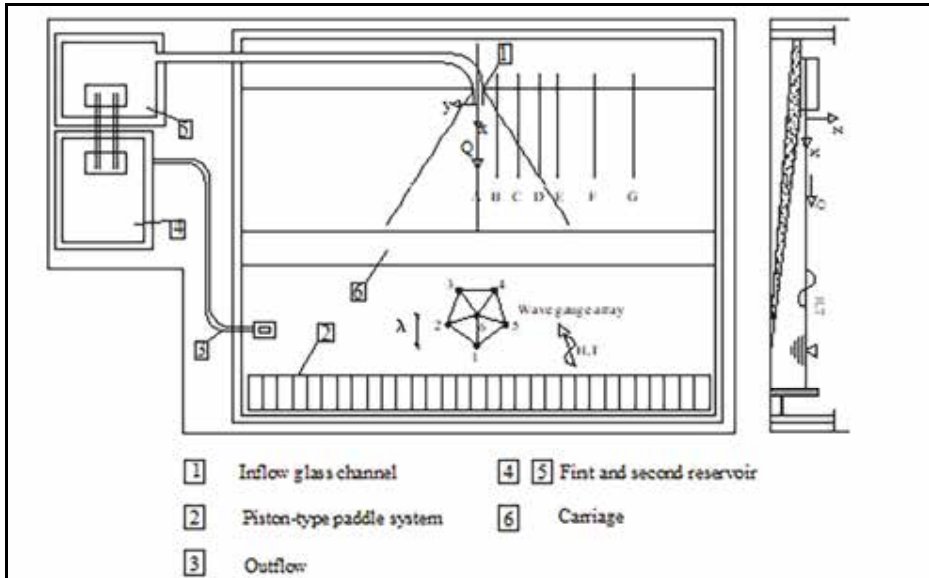

Figure 1 - Maritime Hydraulics Laboratory of the University of Campania.

Water circulation within the marinas

Port of Manfredonia

The new marina at the south-east of the Italian peninsula Ionian coast, is located in a strategic position for south Italy both marine and land traffic (41° N, 15° E). The marina will be realised along the coastline included between Barletta city and headland of Gargano. The highest and most frequent waves interesting the coastline come from the sector 50° N and 140° N. The marina is protected by two emerged breakwaters converging to a central straight entrance with head section depths to -6.50 m sl. The east breakwater is located near to old commercial harbour while the seaward breakwater is positioned at variable depths between $-6.00/-7.00$ m sl. The trunk section breakwaters are constituted from rock rubble mound [3]. The basin has an almost square shape with a triangular shape entrance. Inside of the basin, two rows of five piers are planned, with regular spacing. The seabed, inside the port basin, slopes gently from the water depth of about -2.50 m sl up to $-6.00/-6.50$ m sl near the entrance. The slope of the seabed is constant and equal to 0.015 inside the basin, to then decrease to 0.005 in the entrance where it is almost flat.

The physical model is equal to 1: 120 (Figure 2) to reproduce the entire port basin. The trunk section breakwaters are constituted from rock rubble mound with the weight calculated in according to the Froude's scale; the harbour quays are done by the steel sheet while the floating piers with cork sheet. Particular care it has been taken reproducing the bottom bathymetry, as it strongly influences the motion field within the basin.

To ensure an adequate exchange water volumes within the basin, a system of submerged agitators, arranged in the manhole covers inside the piers, are designed. The

agitators are capable to do the jets characterized by an axial speed of approximately 0.40 m/s. This system was reproduced in the physical model by means of 2.4 cm diameter jet mixers. Each mixer is located at the end of a 30 cm long tube with a diameter of one inch, immersed in a water depth equal 6 cm. It was suitably calibrated so as to determine at the opposite end a current with an axial component of the average time speed of approximately 3.65 cm/s at a distance of 10 cm from the mixer. This value is equal to about 0.40 m/s in the prototype, in agreement with the project velocity. Six mixers have been installed, three of which are located along the quay next to the seaward breakwater and three along the east breakwater. From the preliminary tests, the mixers system was more effective in the withdrawal of water from inside of port basin; instead the inlet of the water from outside basin to inside itself was less strong. The test has been verified with reference to only one of the mixers, located inside the central pier (Figure 2). Coloured floating particles made of cork have been introduced to visualize the motion field induced by the mixer. In Figure 2 it is shown how already after about 1500 s (corresponding to about 5 hours in the prototype), all the tracer particles have been suctioned near the mixer.



Figure 2 - Marina of Manfredonia; Mixer inside the central pier.

Port of Castel Volturno

The Pinetamare Marina near Castel Volturno city (13°58'39" E, 40°58'29" N) is a structure placed respectively to 7 km and to 1 km south of the mouths of the Volturno River and the RRLL canal, along the Domitia coast in the southern Gulf of Gaeta. The port is characterized by two breakwaters done by natural stone. The water volume of the basin is approximately 1 800 000 m³.

The model of the port basin was reproduced in scale 1: 135. The trunk section breakwaters are made with limestone stone of suitable size; the piers has been reproduced with steel sheet while the quays with floating cork sheets (Figure 3). To determine a water exchange within the basin, five submerged jet mixers have been installed along the quay and near the breakwaters (Figure 3). Each mixer, equipped with a 2.4 cm diameter

propeller, was appropriately positioned inside a manhole cover located on the back of the piers. An inch PVC pipe connects the manhole cover itself to the basin through a copper pipe, also one inch in diameter. Before the experimental tests, each mixer was suitably calibrated to determine at the end of the tube a current characterized by an axial component of average time speed of about 9.7 cm/s measured at a 5 cm water depth and at a distance of 10 cm from mixer. This value corresponds in the prototype to about 1.00 m/s, in agreement with project speed. Floating cork particles, suitably coloured, have been positioned in predetermined positions for the photographic visualization of the motion field induced by the agitators inside the basin. In particular, two experimental tests were conducted. The first, in which the devices with a PVC tube take water from inside of the basin and inlet it through the copper tube out of the basin itself and so the floating particles are carried by the mixers near the piers. The second in which the mixers through the copper tube inlet water from outside the basin inside it and so the floating particles are carried by the mixers outside of the basin. With regard to case 1) the tracers placed near the mixers already after 5 minutes from the start of the test are taken by the mixers towards the quays and after 115 minutes still closer. The tracers positioned far from the mixers, although initially taken (at $t=5'$) by the mixers, are trapped in the channel between the piers of basin. With regard to case 2), in Figure are plotted the trajectory of each group. It is evident that in this case, the particles already after 20 minutes from the start of the test are pushed by the mixers through the entrance, remaining here until the end of the test ($t = 115'$). From the comparison of the experimental tests the mixer system is effective in both cases investigated. It should also be noted that the system in the case water inlet inside the port (case 2), all the tracers positioned inside the port basin are pushed towards the entrance, a condition that does not occur in the case of water taken off towards the piers. For the particles remaining trapped in the basin, so it is necessary to install others mixers to allow to exit from the port basin.

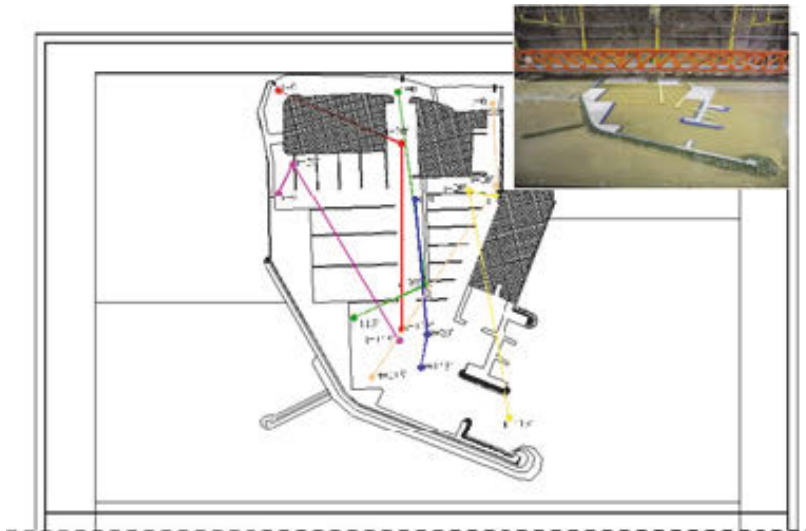

Figure 3 - Marina of Castel Volturno; Trajectory of particles – case 2).

Port of Fiumicino

The new tourist port of Fiumicino will be located in Isola Sacra between Capo Linario in the north and Capo Anzio in the south [5]. The trunk section breakwaters are planned in artificial rocks (162° N - 342° N – Molo Traiano) and natural armour (180° N - 0° N – Molo Claudio). The port basin has a total area of approximately $580\,000\text{ m}^2$, with an entrance of approximately $50\,000\text{ m}^2$. Inside it is planned the construction of four docks; the quays are for both fixed and floating type.

The model of the port basin has been reproduced in scale 1: 135 (Figure 4). The trunk section in model was made with limestone stone elements of suitable size; the docks have been made with steel sheet while the floating piers with cork. In the project, a forced circulation system (jet mixers) was planned with a number of mixer equal to 12 and with a flow rate of 1400 l/s for each of them. In the experimental tests, to simulate the effect of the mixers, a nozzle system was created connected to a hydraulic circuit, each with flow rate of approximately 0.008 l/s, corresponding in prototype to $1400\div 1600$ l/s (project value). The photographic visualization with camera of the motion field induced by the mixers was obtained by introducing floating cork coloured particles.



Figure 4 - Initial position of particles.

In particular, four of the five groups of particles have been positioned, in the initial condition, inside the docks, while the fifth near the port entrance. At the first, the arrangement and the number of the mixer were that in the project (12 mixers). It has been highlighted that this solution is not satisfactory because it determines the large areas of stagnation above all in the inner areas of the port basin. Therefore, other tests have been carried out in which the number of equipment and their position has been changed. In particular, among the experimental tests conducted, those relating to the following two

conditions are reported. A first case in which 18 mixers have been used with a flow rate value of 0.008 l/s and an outlet speed of 0.40 m/s and a second case in which 24 mixers have been installed with a flow rate value and an outlet speed equal to that of the first case. Regarding case 1) all the tracers, although initially affected by the effect of the current generated by the mixers, remain trapped inside the docks and in the channel parallel to Molo Traiano. With reference to case 2), all the particles already a few minutes after the start of the test are pushed by the mixers towards the entrance, leaving definitely the basin at the end of the test (Figure 5). As for the tracers placed in the initial condition inside the central dock, these, although affected by the effect of the current generated by the mixers, remain trapped inside the dock. From the comparison of the experimental investigations carried out, it is clear that the most effective regulator system is that relating to case 2), also with the limitations of effectiveness reference to the central dock.

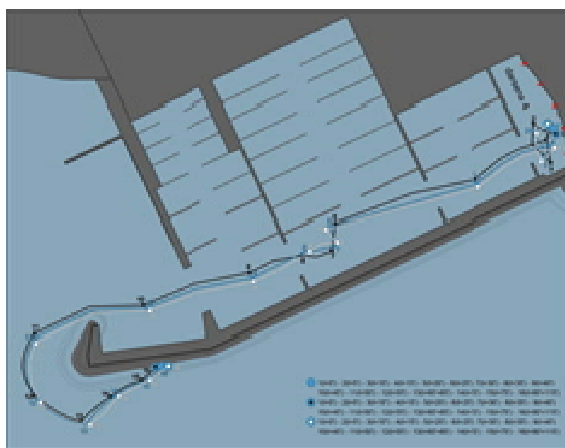

Figure 5 - Trajectory of the particles - case 2).

Water circulation over the defence works

Coast of Salerno

The coast of the Municipality of Salerno, about 12 km wide, is between the Municipality of Vietri sul Mare and the Picentino Torrent. To mitigate intense erosion phenomena an artificial nourishment protected by submerged breakwater spaced out with the gaps has been projected. The submerged level of the breakwater is equal to 0.50 m while the gaps have a submerged level equal to 3.00 m. The defence works are made in natural stones. The scale in a physical model is equal to 1:70 (Figure 6). The trunk section breakwater is made by limestone stone elements of appropriate size. The wave height reproduced in the model is equal to $H_s=0.007$ m, with period $T_s=0.5$ s corresponding to a wave height in the prototype equal to $H_s=0.50$ m, period $T_s=3.20$ s with angle propagation equal to 220° N, 230° N and 240° N. To maintain adequate water quality behind the defence

works, the greatest time for water exchange, as required by the AIPCN standards, is equal to 48 h. The photographic visualization of the motion field induced by the most frequent storms within the protected basin was obtained by introducing cork-floating particles, suitably coloured, in fixed positions. Two experimental tests were made. The first in which the groups of particles have been positioned in the initial condition behind the gaps and the central breakwater in presence of $H_s=0.007$ m $\alpha=0^\circ$ (220° N), $\alpha=10^\circ$ (230° N) and $\alpha=20^\circ$ (240° N). The second in which the groups of particles have been positioned in the initial condition only behind the breakwaters in presence of the same wave conditions (Figure 7). In the case 2), for $\alpha=0^\circ$, the tracers positioned respectively behind second and third breakwaters exit from the protected basin after $D=7$ min from the start of the test and return after about 15 min and definitively move away from the protected area at the end of the test. The remaining tracers, although affected by the effect of the wave storm, stop on the shoreline after $D=2$ min from the start of the test. In the case of wave oblique attack, $\alpha=10^\circ$, the tracers placed behind second and fourth breakwaters move away respectively from the protected basin after $D=14$ min and $D=18$ min from the start of the test while those placed behind the central breakwater respectively after $D=22$ min and $D=49$ min. The remaining tracers initially are influenced for a long enough time by the circulation induced by the storm and then stop on shoreline. For $\alpha=20^\circ$, the tracers placed behind second and fourth breakwaters leave definitively the basin after $D=17$ min from the start of the test; the particles placed behind the central breakwater, although affected at the beginning of the test by the effect of the circulation induced by the storm, stop on shoreline after $D=6$ min. Also in case 1) an adequate water exchange of the protected basin is ensured in the presence of the most “frequent” storms. This action appears more effective as the wave angle attack increases.



Figure 6 - Model of Salerno.

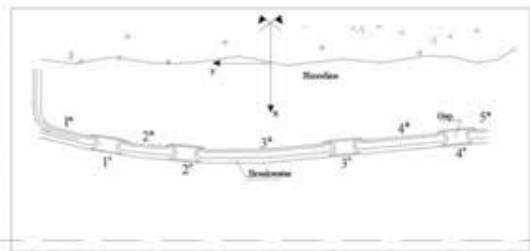

Figure 7 - Scheme of Salerno model.

Coast of Ischitella

The construction of a breakwater with a submerged level of 0.50 m sl has been planned protecting coastline of Ischitella. The breakwater was positioned at the depth ranging between 3.50 m sl and 4.00 m sl. The longitudinal development of the work is 890 m. There are 2 gaps wide 40 m and such as to divide the entire structure into 3 trunks, each of 270 m development; the gaps have a submerged level of -2.50 m sl and a top width equal to 24 m. As a connection the defence work to the coast, other gaps, wide 70 m, have been made at the two ends of the emerged transversal groins [4]. The behaviour of the work

was studied through a 1:50 scale model (Figure 8). Only two breakwaters and two gaps and one of the two emerged transversal groin connected to the coast have been reproduced. The breakwaters have been built with limestone. The wave height reproduced in the model is equal to $H_{sm}=0.01$ m, with period $T_{pm}=0.5$ s corresponding in the prototype to a wave height equal to $H_s=0.50$ m, period $T_p=3.11$ s with angle propagation equal to 240° N and 270° N. The photographic visualization of the motion field induced by the most frequent storm within the protected basin was obtained by introducing cork-floating particles, suitably coloured, in fixed positions. Two test conditions were made in which six groups of particles, positioned in the initial condition behind the gaps (group 3 and 6) and behind the breakwaters (group 1, 2, 4 and 5), were subjected to $H_s=0.01$ m $a=0^\circ$ and $a=30^\circ$. For $a=0^\circ$, groups 1 and 2 stop on the shoreline, although affected at the test beginning by the circulation induced by the storm. The particles of group 3 and 4 go beyond the trunk section 1 and definitively leave from the protected basin after about 50 minutes; groups 5 and 6 immediately leave the basin after the start of the test (about 15 minutes). For $a=30^\circ$, the tracers of group 1 and 2 partly come out from the protected basin through the groin and partly from the gap 2 (Figure 9). Group 3 over pass the trunk section 2 after about 40 minutes from the start of the test; the tracers of group 4, 5 and 6 move away from the protected basin through respectively the trunk section 2 and the gap 2, after a few minutes from the start of the test. It is evident from the comparison of the experimental investigations carried out that the circulation induced by the most frequent storms influences the protected basin. In particular, the time taken by the tracers to move away from the basin, in both cases examined, is significantly reduced if it is compared to that in the project phase. It should also be noted that the effect of the circulation induced by storms on the water exchange in the protected basin increases as the wave angle increases.



Figure 8 - Model of Ischitella.

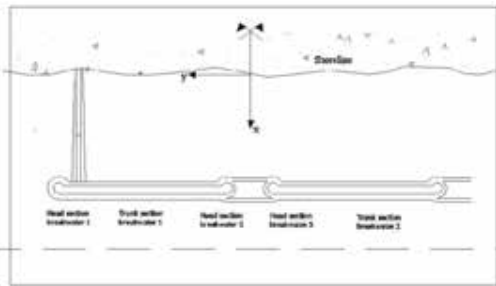

Figure 9 - Scheme of Ischitella model.

Conclusion

The estimation of water circulation on physical model within the port basin of Manfredonia, Fiumicino and Castelvolturno and behind the defense works of Salerno and Ischitella coasts has been reported. The tests were carried out at the Maritime Hydraulics Laboratory of the University of Campania “Luigi Vanvitelli”. For the Port of Manfredonia,

a forced circulation system activated by electromechanical equipment arranged inside the docks can ensure adequate water exchange within the port basin itself. This device appears more effective with jet mixers conveying the water sucked from inside towards outside of the basin. The mixers located inside of Castelvolturno port that inlet water inside the port taking it from outside, are instead more effective. The most suitable forced circulation system for Fiumicino port is that with a greater number of mixers than those provided in the project. This system allows pushing out all the tracers towards outside of basin, except for those positioned inside the central dock. As far as coastal defence works concerned, an adequate water exchange of the protected basin is ensured for both Salerno and Ischitella coasts in the presence of the most “frequent” storms. This action appears more effective as the wave angle attack increases.

Bibliography

- [1] Di Natale M., Eramo C., Vicinanza D. (2008) - *Experimental investigation on beach morphodynamics in presence of subsidence*, Journal of Coastal Research.
- [2] Di Natale M., Di Ronza S., Eramo C., Vicinanza D. (2008)- *Il laboratorio di idraulica marittima della SUN: caratteristiche e potenzialità*, Atti del 31° Convegno di Idraulica e Costruzioni Idrauliche, Perugia.
- [3] Di Natale M., Di Ronza S., Eramo C., Vicinanza D. (2010) - *Experimental study at port of Manfredonia (Italy)*, Atti del 32° Convegno di Idraulica e Costruzioni Idrauliche.
- [4] Di Natale M., Di Ronza S., Eramo C. (2012) - *Indagine sperimentale in vasca per la verifica delle opere di difesa ambientale del Litorale Domitio*, Simposio Monitoraggio Costiero, Livorno.
- [5] Di Natale M., Di Ronza S., Eramo C. (2014) - *Indagine sperimentale per la verifica del funzionamento idraulico e strutturale del porto turistico di Fiumicino (RM)*, Simposio Monitoraggio Costiero, Livorno.
- [6] Frigaard P., Brorsen M. (1995) - *A time domain method for separating incident and reflected irregular waves*, Coast. Eng. 24.
- [7] Kamphuis J. W. (1972) - *Scale selection for wave models*, Report no 71 of Queen's University C.E, Ontario, Canada.
- [8] Kamphuis J. W. (2000) - *Introduction to Coastal Engineering and Management*, Advanced Series on Ocean Engineering, 16, World Scientific.

ADVANCES ON COASTAL EROSION ASSESSMENT FROM SATELLITE EARTH OBSERVATIONS: EXPLORING THE USE OF SENTINEL PRODUCTS ALONG WITH VERY HIGH RESOLUTION SENSORS

Paula Gomes da Silva¹, Anne-Laure Beck², Jara Martinez Sanchez¹,
Raul Medina Santamaria¹, Martin Jones³, Amine Taji², and all the members
of the “Coastal Change” group within BGS, GIS, IHC, Arctus, UCAR, and IGNFI

¹ Environmental Hydraulics Institute “IH Cantabria”, Universidad de Cantabria,
C/Isabel Torres 15, 39011, Santander, Spain

² Argans France, 260 Route du Pin Montard, 06410 Biot

³ Argans UK, 1 Davy Road, Plymouth Science Park, Derriford, Plymouth, PL6 8BX UK

Abstract – This work proposes the use of automatic co-registered satellite images to obtain large, high frequency and highly accurate shoreline time series. Very high-resolution images are used to co-register Landsat and Sentinel-2 images to reach a vertical and horizontal spatial accuracy within 3 m. Satellite derived shorelines presented positioning errors lower than mission pixel’s resolution. A discussion is presented on the applicability of those shorelines through an application to Tordera Delta (Spain).

Introduction

Climate Change and human activity are likely to have an increasingly dramatic effect on coastal zones. The analysis of the effects on the coast requires better knowledge and more regular and efficient monitoring in order to manage and mitigate impacts of the changing coastal environment. Although in-situ measurements are highly efficient on capturing coastal parameters and features at a given time, the cost of continuous acquisition campaigns is dissuasive. Earth Observations provide wide spatial coverage over a large temporal scale. However, the lack of geolocation accuracy (i.e. the position of details and features usually visible on HR satellite imagery) challenges the conclusions of most academic studies. Spatial accuracy is defined for this study as the conformity in location between the different earth observations and a reference, in a way that an object in a set of images is located at the same location, while the precision is the spatial shift of the objects from what is actually observed in situ. The specific dynamics linked with the coastal environment imply additional constraints due to the different scales of the studied phenomena. Coastal processes, which impact the coastal morphology, are characterized by high temporal variability, ranging from a few hours or days (e.g. storms or artificial beach nourishments) to years or even decades (e.g. Metonic cycles and sea level rise).

The reduced spatial and time scale of coastal changes makes high spatial accuracy necessary and this is under constant improvement (e.g. [7]). The application of the geo-location method, for example, greatly improves the spatial accuracy and allows features inter-location around a few meters accuracy, although such procedure can be time consuming. While the use of automatic methods to obtain geo-located images can be very effective, so far it has not

been tested with the focus on detecting coastal changes (e.g. [11]). On the other hand, it is the temporal variability that challenges the most coastal analysis. While there is an evident interest on obtaining long, high frequency and high accurate time series from EO products, building a stable statistical data set from them is a challenge. [14], for example, demonstrated that current available satellite data from optical sensors are suitable to represent shoreline changes in inter-annual to decadal time scales, but could not explain sub-annual variations.

This study proposes the use of automatic co-registered satellite images to obtain long, high frequency and high accurate shoreline time-series. These Satellite Derived Shorelines (SDSL) are used to compose long and high frequency time series. The applicability of those products is demonstrated with a study case at Malgrat beach (Tordera Delta - Spain) in which shoreline variation is assessed in different time-scales.

Materials and Methods

Malgrat beach is located southward of Tordera river mouth (forming the Tordera Delta) in the northern coast of Cataluña (Spain – Figure 1a). The longshore sediment transport occurs predominantly from NE to SW in Cataluña coast. Over years, the water capture along the river basin and the construction of port structures on the coast northwards of Tordera River (e.g. Port of Blanes), have led to a considerable reduction of the sediment input and have resulted in intense erosion of Malgrat beach ([9], [2]). In the 90's, a considerable amount of sand was recovered from the shallows in front of the mouth of the Tordera river in order to re-nourish beaches in Cataluña. The resultant trough in the sea floor is now a sink to the sediment and makes redistribution of the sand along the coast difficult.

In the past decades, this coast suffered a maximum shoreline retreat of about 120 m (Figure 1b and Figure 1c), with erosion rates reaching -3.8 m/year ([5]). Rapid retreat of about 25 m can also result from single storm events ([6]), a value that can be enhanced due to changes in wave conditions derived from Climate Change ([10]). These issues led to the need for numerous interventions, including soft stabilization and nourishment projects (Figure 2). Nonetheless, these initiatives did not prevent the erosion occurring, and a large urban area has been lost due to shoreline retreat.

The historical shoreline variation at Malgrat beach is characterized by a sequence of retreats due to storm induced erosion events alternated with punctual human-induced progradation (Figure 2). In 2008, for example, the San Esteve Storm, desolated Cataluña coast and resulted in significant shoreline retreat at Tordera Delta [4]. In May 2015, the continuous erosion required the authorities to carry out a project to restore and protect the beach, with the construction of geotextile groins and the dumping of 112 000 m³ of sand (Figure 2b). In the following November, a storm event hit the Cataluña coast and a significant amount of the sand dumped on the beach in the previous months was lost. In January 2017, a sequence of storm events again made the shoreline retreat (Figure 2c), reaching a maximum on 19th-23rd of that month. The most recent event with significant magnitude occurred on January 2020, a weather event named the Gloria Storm, which damaged urban areas near the coast due to severe wave and storm surge conditions. As part of the plan to monitor the area, in situ measurements were taken, for example, on November 11th 2015, and May 2017. All the occurrences outlined above make this area an interesting site for EO application in different time scales, since change due to long-, mid- and short-term processes take place in it.



Figure 1 - Location of the study case site (a), Malgrat beach (Spain) and situation of the coast in 2004 (b) and 2018 (c). The yellow polygon indicates the coastal area lost due to erosion problems along the 14 years.

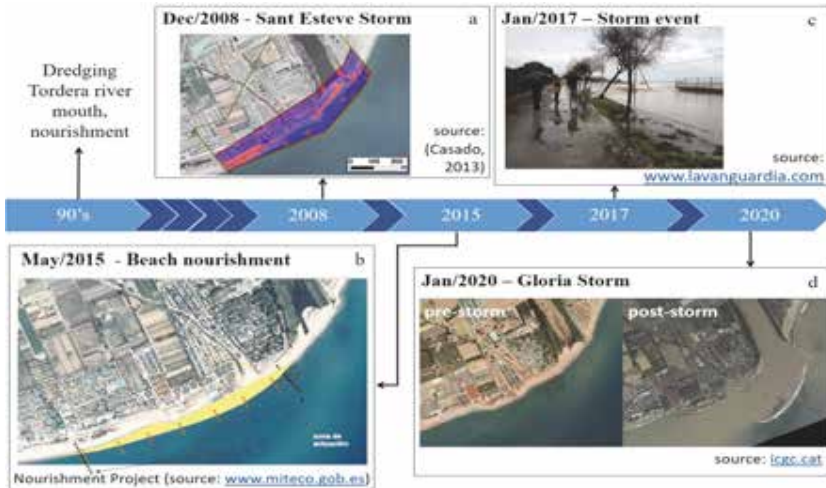

Figure 2 - Timeline of punctual actions/events that took to expressive shoreline variability of Malgrat beach. a) 2008: results from LiDAR analysis from [8] where red colors indicate sediment lost areas due to Sant Esteve Storm. b) 2015: nourishment project carried out to restore the beach. c) 2017: effects of the storm registered by local news. d) 2020: aerial photos taken of previous and posterior to the Gloria Storm.

For this study, we use a combination of several optical sensors to increase the number of observations over our area of interest and to obtain longer time series. Landsat 5 & 8 and Sentinel-2 data were combined to cover a wider time range (1994-2018) and to increase the number of observations over a same site. Very High Resolution (VHR) imagery is used to co-register the Sentinel-2 and Landsat data. Those VHR are obtained from commercial missions. Maxar's WorldView 2 data were used for the co-registration of HR images over Tordera area. Table 1 details the specification of the different missions used.

Table 1 - EO missions and their specifications with optical sensors.

Satellite constellation	sensor & bands (optical)	pixel resolution of L1 products	Revisit time	Years active
Landsat 5	0.45÷0.52 μm , 0.52 ÷ 0.60 μm , 0.63 ÷ 0.69 μm , 0.77 ÷ 0.90 μm	30 m		
Landsat 8 (OLI)	0.503 ÷ 0.676 μm	15 m	16 days	2013 –
	0.435 ÷ 0.451 μm , 0.452 ÷ 0.512 μm , 0.533 ÷ 0.590 μm , 0.636 ÷ 0.673 μm , 0.851 ÷ 0.879 μm	30 m		
Sentinel-2 A & B /MSI	448÷546 nm, 537÷583 nm, 645÷683 nm, 762÷908 nm	10 m	5 days	2015 –
	604÷723 nm, 731÷749 nm, 768÷796 nm	20 m		
	430÷467 nm, 932÷958 nm	60 m		
WV-2	450÷800 nm	0.46 m	1 day	2009 –
	400÷450nm, 450÷510 nm, 510÷580 nm, 585÷625 nm, 630÷690nm, 705÷745 nm, 770÷895 nm, 860÷1040 nm	2 m		

Optical observations were used to compose large and high frequency time series of shorelines. For that purpose, the waterlines (the observed instance in time of the boundary between land and sea) need to be extracted with a very high location accuracy. However, from one sensor to another and from one acquisition to another, we observe a spatial shift (i.e. EO observations have errors and uncertainties that lead to different positioning). For Landsat-8 the geo-location accuracy is around 30 m, while for Sentinel-2 L1C (without ground control points) the accuracy is around 10 m at 2σ confidence level [3]. To correct the displacement between images, VHR imagery with high location accuracy, are used as a master to co-registered observations of the different sensors. VHR were pre-processed to correct and remove the effect of haze vapor, then, the ASORICS (Automated and Robust Open-Source Image Co-Registration Software) [11] was used to apply the Fourier shift theorem in order to determine precise X/Y offset at a given geographical position through phase correlation. This process can only be applied for single band images with same spatial resolution and, ideally, similar pixel intensity. This criterion is not fulfilled when dealing with multi-temporal and multi-spectral data from different sensors, therefore, we combined a pure phase correlation approach with additional processing and evaluation modules.

Once the satellite images were geo-located, waterlines were obtained and transformed to datum (Mean Seal Level REDMAR – *Red de Mareógrafos de Puertos del*

Estado) based shorelines using the beach slope and sea water level (observed sea level at the coast including tide, surge and wave data). SDSLs were validated for the study site using data from in-situ measurements. SDSLs closest to measurement days (maximum ± 7 days) were compared with in-situ shorelines at transects displaced every 15 m along the coast. The cross-shore distance between in-situ measured data and the SDSL was used as an error measure to calculate the Mean Absolute Error (MAE) and the Brier Skill Score (BSS, [12]). Perfect agreement gives a BSS of 1, whereas observing the baseline condition (first SDSL from 1994) gives a score of 0. Additionally, shoreline variations were compared to results presented in previous studies.

A detailed analysis of shoreline variation on Malgrat beach was carried out to show the potential of co-registered SDSL time series to assess coastal changes in different timescales. A total of 184 shorelines from 1994 to 2018 were used to assess short-, medium- and long-term shoreline variation. Long-term trends in shoreline changes were estimated using the Digital Shoreline Analysis System, DSAS [13]. Shoreline evolution was assessed to verify the changes in trends of Tordera Delta coast. Short term application was assessed through the analysis of the shoreline movement in two events: i) a nourishment event carried out in May 2015 and the subsequent storm erosion in November 2015, and ii) a sequence of storms on January 2017 (see list of events in Figure 2).

Results

The co-registration process, performed on all public images, allows the relocation and the perfect overlap from one EO image within the same tile to another. In 90 % of cases, the co-registered images showed horizontal and vertical shifts below 3 m in comparison to VHR. In other words, all images are repeated within 3m of their true location.

In-situ measurements and SDSL from November 2015 are used for validation. The shorelines are presented in Figure 3, as well as the baseline used to calculate the BSS. Here, the baseline was taken as the earliest SDSL available (from 1994). The MAE between both shorelines was equal to 21 m, falling within the range of the horizontal accuracy of Landsat 8, which is typically 30 m. BSS was equal to 0.96 which indicates good agreement between measured and satellite data and the ability to represent long-term variations. Shoreline variation rate, calculated using SDSLs, also agrees with values presented before. [1], used high-resolution aerial photographs and obtained an average erosion tendency of -4.68 m/year between 1995 and 2009 in the coast southward of Tordera river mouth, a value similar to the one obtained here using the SDSL (-4.79 m/year) for the same period.

Discussion

The co-registration process results in images with high spatial accuracy, however the global quality depends on the number of ground points that the processor is able to use to adjust the images. Points selection, which is linked with weather conditions such as cloud cover and type of land use (points extraction is more reliable over man-made structures, over build-up areas than over natural environment such as forest or over large crops field) is a vital step in establishing the process.

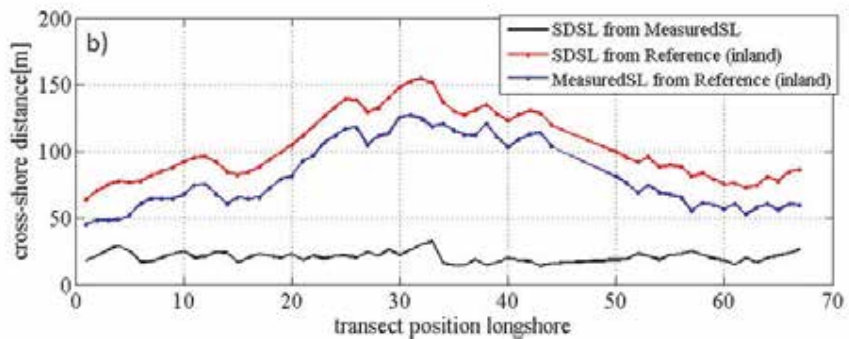
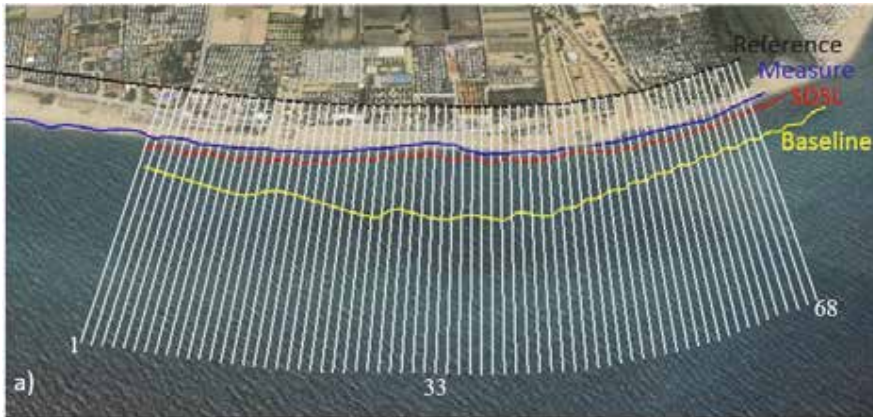

Figure 3 - a) Position of the cross-shore transects, shorelines (measured and satellite) and reference line; b) cross-shore distances between shorelines and between shorelines and the reference.

The increment in accuracy obtained through co-registration allows more reliable analysis of coastal changes in different time-scales. Here we show the applicability of this kind of product to both a long-term, (annual) and event scale. The net shoreline movement and the variation rate (calculated with a linear regression method) obtained from the long-term analysis are presented in Figure 4. Negative values indicate erosive processes. A retreat tendency is observed along the whole beach, with maximum of -6.19 m/year in the central area and minimum of -2.28 m/year in the northern zone. The most critical area shows a retreat of almost 150 m during the period of 25 years analysed (e.g. transect 33). The evolution of shoreline displacement and the yearly average of the variation rate are also represented in the Figure 4c, in terms of distance from the reference line, which is located inland (see reference line location in Figure 4a). Although some increment can be observed along the time series (e.g. years 1997, 2005 and 2015 in Figure 4c), a general retreat is clear over the 25 years, and is especially critical on transect 33. This critical zone corresponds to the area typically used by camping services (example of urban services occupying the dry beach) and which was completely removed due to long-term processes and due to extreme storm events.

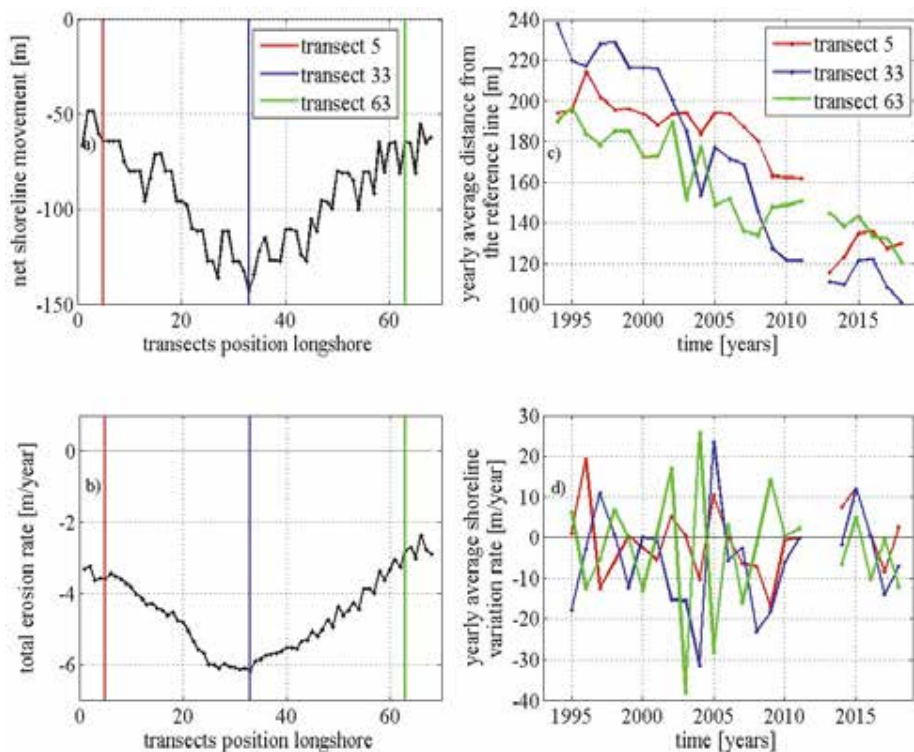

Figure 4 - Long-term analysis (SDSL 1994-2018). Spatial assessment: a) net shoreline movement along the beach, b) variation rate along the beach (negative values indicate erosive process). Temporal assessment: c) average distance from the reference line located inland, d) average shoreline variation (negative values indicate erosive process).

The most recent reported extreme events that affected Malgrat occurred over three distinct episodes, on November 2015, January 2017 and January 2020, and they contributed to the significant reduction of the beach width. The analysis of short-term shoreline variation (e.g. storms and nourishment) using satellite images is quite challenging due to the usual lack of short-term registers. In addition, clouds are frequently an issue obscuring optical detection during storms. While the problem related to clouds cannot be solved for shorelines derived from optical sensors, the increment on the frequency of acquisition and accuracy in recent satellite missions is a step forward and allows for the punctual analysis of events capable of moving considerable amounts of sand from the coast. Here, we analyze the shoreline evolution during 2015 and 2017 events individually by assessing the shorelines registered immediately before and immediately after those events.

Shoreline advance due to the nourishment carried on May 2015 is represented in Figure 5a (SL movement 1: movement from March 2015 to June 2015). A maximum advance of about 60 m was observed and agrees with the nourishment project presented by that date (see Figure 4b). The following storm event (November 2015) that hit the shoreline causing

retreat was also detected (SL movement 2: movement from June 2015 to November 2015) leading to the displacement of the coast up to 40 m landward. In the following months, the retreat continued along almost the entire shoreline, moving up to 30 m landward in some areas (e.g. transects 2 to 17 and transect 57).

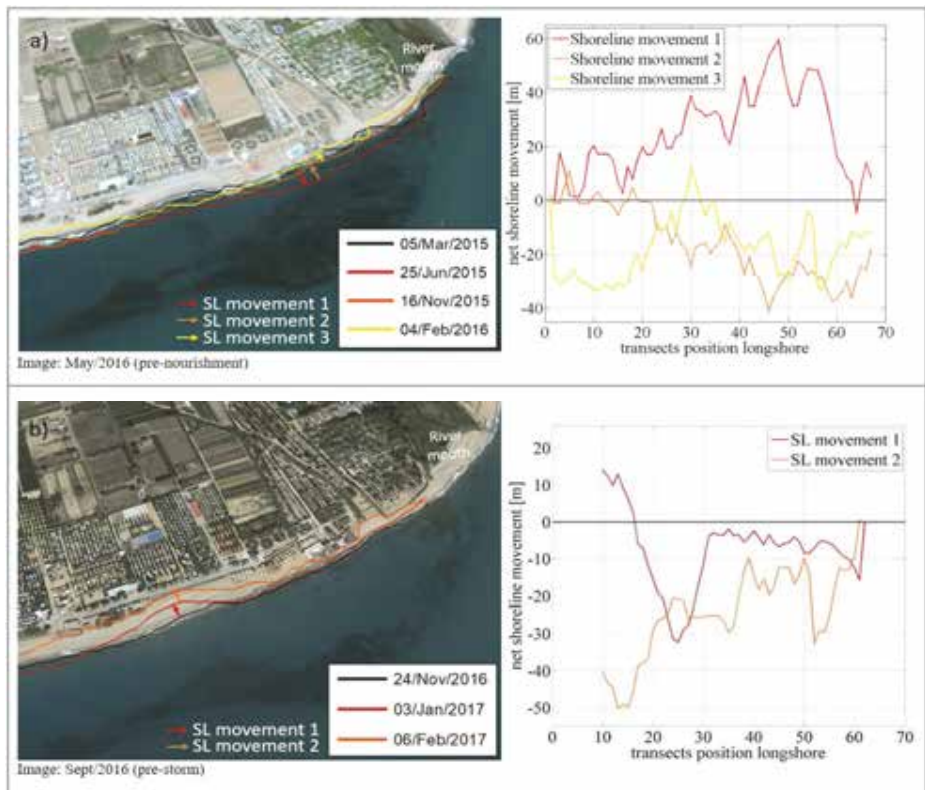

Figure 5 - Shorelines pre and post events from 2015 (nourishment and storm erosion - a) and 2017 (sequence of storm erosions - b). Left panels show the net shoreline movement between the shorelines register.

The sequence of storm events that occurred on January 2017, is represented in Figure 5b. The initial shoreline retreat observed from November 2016 to January 2017 (SL movement 1) reaches values of about 30 m in the critical area around transect 25. The erosion problem is enhanced in the following month (SL movement 2: movement from Jan/2017 to February 2017), in which the retreat occurs over the previously retreated shoreline. The shoreline advances over the camping area and reaches the sea front as observed in-situ (see Figure 2c).

Conclusions

The analysis presented here showed the potential use of large and dense SDSL time-series, populated with products from multiple satellite missions to enable the analysis of long-term variations. The importance of applying the co-registration method, which improves the spatial accuracy, on the assessment of coastal variability was also discussed. This well-known methodology has been extensively explored in the past for many purposes, but the automatic application and its use to assess coastal changes is an important innovation.

The increased frequency of acquisition in recent satellite missions allowed the analysis of short-term events to demonstrate significant shoreline variations (variations higher than the shoreline accuracy). Such advances are a step forward and improve the analysis of the effect of storm events and nourishment on shoreline variations. The possibility of using products from radar sensors (not explored here), which allow shoreline acquisition under cloudy conditions, may also grant important additional analysis of this kind of events, and will be further explored in a future work.

Acknowledgments

We acknowledge the *Ministerio para la Transición Ecológica y el Reto Demográfico* (MITERD), *Puertos del Estado* and IHCantabria for providing auxiliary data. We also thank to the *Instituto Geográfico Nacional* (IGN – Spain) and the ESA Third Party Mission agreement for making the VHR images available for this study. This work was financially supported by the Coastal Erosion Project – ESA. The Coastal Erosion project is funded via the Science for Society slice of the 5th Earth Observation Envelope Programme (EOEP-5) of the European Space Agency. Special thanks are also given to the Coastal Change Consortium, a partnership bringing together the delivery of products team, comprising ARGANS Ltd, IsardSAT & AdwaisEO, and the User Group comprising IH Cantabria, the British Geological Survey, Geological Survey of Ireland and Arctus in collaboration with the University of Quebec at Rimouski. This partnership is unique in that it brings those professional users who advise their governments together with Earth Observation technical expertise.

References

- [1] Blasco, D. (2011) - *Evolución costera del Maresme Norte (Blanes-Arenys)*. Case. Master's Thesis, Faculty of Civil Engineering, Universitat Politècnica de Catalunya, Barcelona, Spain. Available online: <https://upcommons.upc.edu/handle/2099.1/12961> (accessed on 21 June 2020).
- [2] CEDEX – Centro de Estudios y Experimentación de Obras Públicas (2014) - *Estudios de dinámica litoral, defensa y propuestas de mejora en las playas con problemas erosivos, considerando los efectos del cambio climático: Estrategia de actuación en el Maresme*. Madrid. Available online: [https://www.miteco.gob.es/es/costas/temas/proteccion-costa/Estrategia%20de%20actuacion%20en%20el%20Maresme%20\(Final\)%20AVANCE%20\(1\)-optimizado_tcm30-163212.pdf](https://www.miteco.gob.es/es/costas/temas/proteccion-costa/Estrategia%20de%20actuacion%20en%20el%20Maresme%20(Final)%20AVANCE%20(1)-optimizado_tcm30-163212.pdf) (accessed on 27 June 2020)

- [3] Clerc, S (2020) - *Sentinel-2 L1C Data Quality Report*. Available online: https://sentinel.esa.int/documents/247904/685211/Sentinel-2_L1C_Data_Quality_Report (accessed on 26 June 2020)
- [4] Jiménez, J.A. (2012) - *Characterising Sant Esteve's storm (2008) along the Catalan coast (NW Mediterranean)*. In Mateo, M.A., Garcia Rubies, T., (Eds) *Assessment of the Ecological Impact of the Extreme Storm of Sant Esteve's Day (26 December 2008) on the Littoral Ecosystems of the North Mediterranean Spanish Coasts*; Final Report (PIEC 200430E599); Centro de Estudios Avanzados de Blanes, Consejo Superior de Investigaciones Científicas: Blanes, Spain, 2012; pp. 31–44. Available online: http://www2.ceab.csic.es/GAME/Sant_Esteve_Storm/Contributions.html (accessed on 25 June 2020)
- [5] Jiménez, J.A., Gracia, V., Valdemoro, H.I., Mendoza, E.T., Sánchez-Arcilla, A. (2011) - *Managing erosion-induced problems in NW Mediterranean urban beaches*. *Ocean Coast. Man.*, 54, 907-918.
- [6] Jiménez, J.A., Sanuy, M., Ballesteros, C., Valdemoro, H.I. (2017) - *The Tordera Delta, a hotspot to storm impacts in the coast northwards of Barcelona (NW Mediterranean)*. *Coast. Eng.*, 134, 148-158.
- [7] Liu, Q., Trinder, J., Turner, I.L. (2017) - *Automatic super-resolution shoreline change monitoring using Landsat archival data: a case study at Narrabeen-Collaroy Beach, Australia*. *J. Appl. Remote Sens.*, 11, 016036.
- [8] Plana-Casado, A. (2013) - *Storm-Induced Changes in the Catalan Coast Using Lidar: The St. Esteve Storm (26/12/2008) Case*. Master's Thesis, Faculty of Civil Engineering, Universitat Politècnica de Catalunya, Barcelona, Spain. Available online: <http://hdl.handle.net/2099.1/23343> (accessed on 21 June 2020).
- [9] Rovira, A., Batalla, R.J., Sala, M. (2005) - *Response of a river budget after historical gravel mining (the lower Tordera, NE Spain)*. *River Res. Appl.*, 21, 829-847.
- [10] Sanuy, M., Jiménez, J.A. (2019) - *Sensitivity of storm-induced hazards in a highly curvilinear coastline to changing storm directions. The Tordera Delta Case (NW Mediterranean)*. *Water*, 11, 747.
- [11] Scheffler, D., Hollstein, A., Diedrich, H., Segl, K., et Hostert, P. (2017) - *AROSICS: An Automated and Robust Open-Source Image Co-Registration Software for Multi-Sensor Satellite Data*, *Remote Sens.*, 9 (7), 676.
- [12] Sutherland, J., Peet, A.H., Soulsby, R.L. (2004) - *Evaluating the performance of morphological models*. *Coast. Eng.*, 51, 917-939.
- [13] Thieler, E. R., Himmelstoss, E. A., Zichichi, J. L., & Ergul, A. (2009) - *The Digital Shoreline Analysis System (DSAS) version 4.0-an ArcGIS extension for calculating shoreline change* (No. 2008-1278). US Geological Survey. doi: 10.3133/ofr20081278
- [14] Vos, K., Harley, M.D., Splinter, K.D., Simmons, J.A., Turner, I.L. (2019) - *Sub-annual to multi-decadal shoreline variability from publicly available satellite imagery*. *Coast. Eng.*, 150, 160-174.

DIACHRONIC EVOLUTION OF THE COASTLINE OF BORDJ EL KIFFANE (ALGIERS, ALGERIA) IN ABSENCE AND PRESENCE OF COASTAL PROTECTION STRUCTURES

Ismahane KADRI ¹, Farid ATROUNE ¹

¹Laboratory Geo-environment – University of Science and Technology Houari Boumediene, Algiers, (Algeria),

phone +213 668997044, e-mail: minakadri.ik@gmail.com, faridatroune@gmail.fr

Abstract – The coastline is one of the country’s most important environmental and economic resources. However, it is a delicate and highly coveted environment on which many factors of evolution interact, both anthropogenic and natural [1]. The anthropization of the shoreline accelerates the trends of evolution which lead to other human interventions by implanting hard protective structures that can cause other impacts and even accelerate erosion rates. [2]

The coastal area of Bordj El Kiffane, located in the central part of Algiers Bay in Algeria, has experienced an artificialisation of its shoreline translated by the strong urbanization since 1980 and development of several anthropogenic activities on its coast. This caused a remarkable decline of the shoreline. To remedy this, the solution recommended by the Maritime Studies Laboratory is the combination of several protection methods: shore-connected break-waters, groins, seawalls and nourishment of the sandy beach on the west of the study area. [2]

In order to determine the consequences of the implementation of these protective structures, a study of the historical evolution of the coastline was performed with ArcGIS and its extension Digital shoreline Analysis System (DSAS) as a means of monitoring. The methodology followed consists of the application of automatic analytical techniques, based on a geomatics approach using multi-temporal photo-interpretation on a period of 38 years. The change rates using the End Point Rate EPR and Net Shoreline Movement NSM were calculated by the DSAS tool and mapped to facilitate their interpretation. The surface evolution has been also estimated to quantify the sediment budget in case of erosion or accretion of the shoreline.

The Diachronic evolution of the coastline of Bordj El Kiffane area allowed determining its evolutionary rates and comparing the evolutions on different periods in absence and presence of the protection structures.

Introduction

The coastline in general is characterized by its extreme diversity and by the speed of its evolution. It is an environment that depends at the same time on the nature of the substratum, on the quantity of sedimentary contributions and on marine dynamics, continental and / or anthropic factors. [3]

In general, the coastline of Algiers Bay is in decline. Erosion is due to natural factors governing coastal dynamics and anthropogenic action, in particular, the extraction

of sand and urbanization close to the coast. The sum of all these factors results in the alteration of the natural balance of the coast. [4]

The Bordj El Kiffane area was the subject of a detailed study of its sedimentary dynamics as a part of my engineer degree project entitled: ‘Consequences of the establishment of protective structures on the coastal fringe of Bordj El Kiffane (Algeria)’ in 2017, followed by an article publication in the Revue Paralia in 2018. In addition, Bordj El Kiffane is one of the areas studied in my doctoral work entitled: ‘Mapping of surface sediments of the Algerian continental platform of the central region of Algeria’ since 2018.

Study area

The region is marked by a predominance of winds from the East-North-East and West-South-West directions, with maximum speeds reaching 20 m/s for the directions between 240° and 270° north. Also for directions between 45° and 90° north, wind speeds are reach 16 m/s. [4]

The Northeast swells are the most frequently observed. Storms mainly come from the western sector. The North sector has a fairly regular distribution during the year [4]. The most energetic swells are those of the Northeast, which generate currents with speeds of the order of 1.65 m/s. They induce coastal drift currents with dominance from east to west, eddy currents inside the breakwater basins as well as a weak rip current. [2]

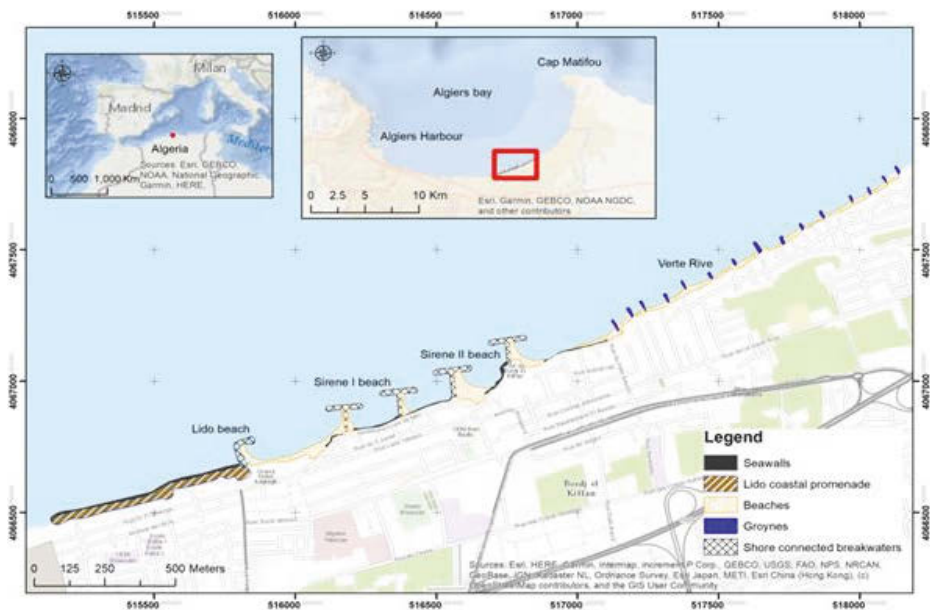

Figure 1 - Map of the location of the study area.

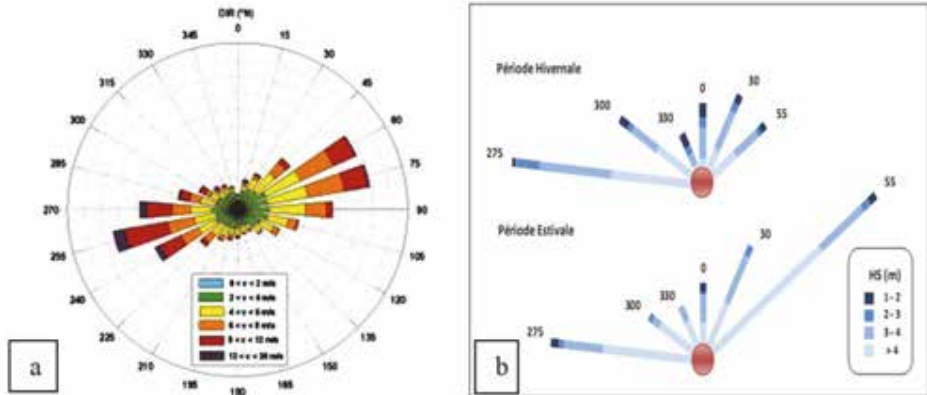

Figure 2 - a: Wind direction rose of Algiers Bay [4] and b: Swell direction roses on the offshore of Algiers Bay [5].

Erosion factors

Among the factors aggravating erosion on the study area, the natural factors (activity of winds and swells) combined with human factors such as the excessive extraction of aggregates, the construction of dams upstream rivers and urbanization. The region of Bordj El Kiffan was a commune with agricultural and tourist vocation but its urbanization reduced it to a very urbanized commune. Agricultural land has been sacrificed in favor of urbanization.



Figure 3 - Illustration of urbanization in the Bordj El Kiffane area between 1960 [6] and 2018 (Credits Anonymous).

The first touristic potential in this city is the beaches, which once made the glory of the town, are in a deplorable state now, the situation of the beaches in the sixties and after the artificialization of the coastline is illustrated by the photos below. These photos show the great loss of in width of the beaches and the change in their profiles and slopes with the disappearance of some of them and their replacement with seawalls.

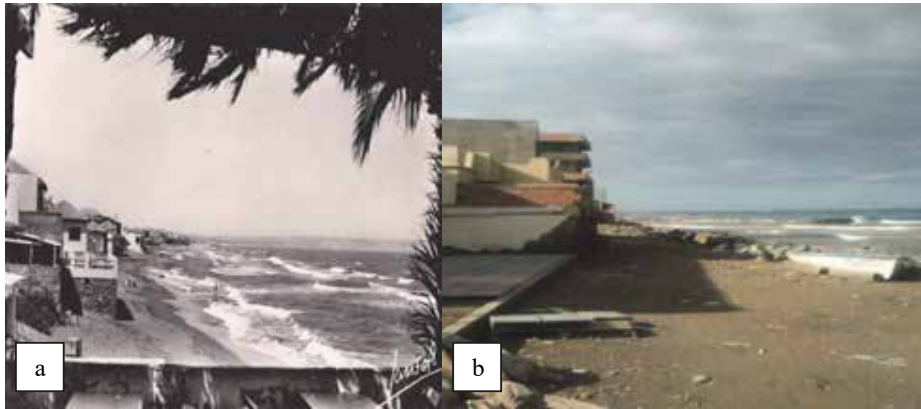

Figure 4 - Verte Rive a : in 1960 [6], b : in 2019 (Credits :KADRI I.).

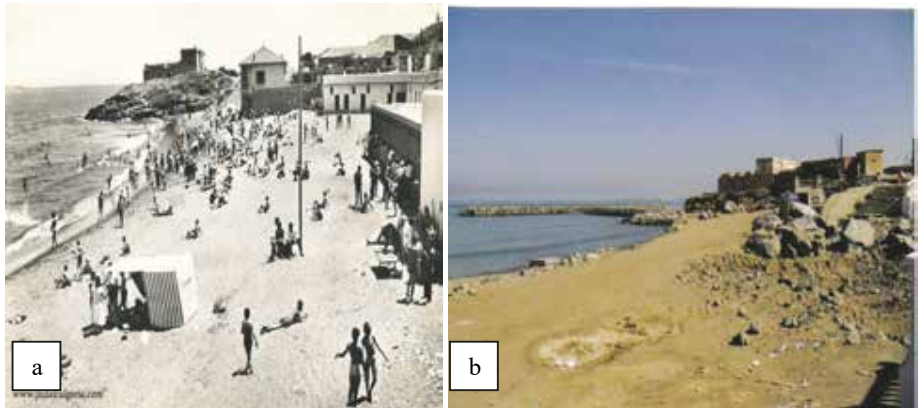

Figure 5 - Sirene II a: in 1960 [6], b: in 2018 (Credits: KADRI I.).

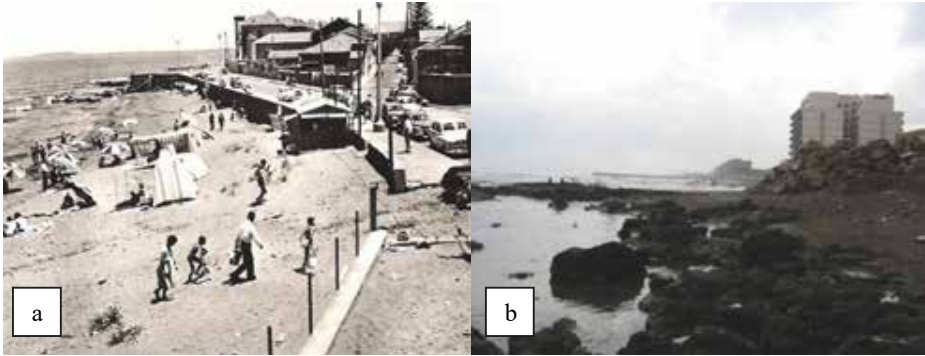

Figure 6 - Lido a: in 1960 [6], b in 2009 (Credits: LEM).



Figure 7 - Sirene I a: in 1960 [6], b: in 2017 (Credits: KADRI I.).



Figure 8 - Sirene I and Sirene II and the coastal promenade a: in 1960 [6], b: in 2017 (Credits KADRI I.).

History of management of Bordj El Kiffane

The vulnerability of the study area to the erosion hazard necessitated its protection by the installation of different types of hard and soft protective structures: a battery of 15 groynes on the Verte Rive site in 2002, seawalls and rock fill to protect the beaches and the houses from wave action, T-shaped mixed protection structures, on a length of 1560 m on the Sirene I and Sirene II sites in 2007 and the creation of an L-shaped breakwater to keep the reloading carried out at the Sirene I beach as well as the realization of a promenade on the site of Lido in 2012. This was in order to protect the bordering houses by reducing the hydrodynamic energy as well as by widening the beach.



Figure 9 - Illustration of protective structures at the study site (Photo taken by a drone in 2019, Credits: Anonymous).

Material and methods

The analysis of the coastline evolution was carried out by the combination of different types of data and it consists of the application of automatic analysis techniques based on a geomatic approach. The documents used are summarized in the following table:

Table1 - Summary of the data used.

Date	1980	2003	2007	2012	2018
Type	2 aerial photographs	2 aerial photographs	2 aerial photographs	Ortho-photographie	Field survey

These documents were treated in several steps with:

- The treatment of aerial photographs and satellite images under ArcMap
- After correcting the aerial photographs, the step of digitizing the coastlines is applied, this was done using the ArcMap module of the ArcGis 10.4 software, where a new personalized database containing the shoreline features and the baseline was created.
- The estimation of global correction errors using the following formula:

$$E_g = \pm \sqrt{E_p^2 + E_r^2 + E_d^2 + E_s^2} \quad 1$$

Using: the resolution of the photos, the error due to the rectification E_r , the error of digitization E_d and the error due to the seasonal variations [7].

Table 2 - Estimated errors induced when treating shorelines data.

Period	1980	2003	2007	2012	2018
Error (m)	3.12	3.12	1.62	0.62	2.12

- Another feature class for transects has been created and evolution rates have been calculated on nearly 250 transects 10 meters apart along the coast.



Figure 10 - Digitizing of the shoreline and the baseline as well as the realization of the transects using the DSASv5 tool.

- Analysis of the diachronic evolution of the coastline using the DSAS v5 extension and the estimation of eroded surfaces and those accreted as well as the calculation of the statistics of evolution of the coastlines using the Net Shoreline Movement NSM and the End Point Rate EPR as follows:

$$R = D/T_e \quad 2$$

Where: R: is the speed in meters per year (m/year), D: is the distance in meters (m) and Te: is the time between the most recent and the oldest coastline (years) [8].

Results and discussion

Evolution between 1980 and 2003 (23 years)

This period is marked by an average accretion of 0.24 m/year in the eastern part. On the other hand, in the western part, erosion has taken advantage over accumulation with an average decline estimated at -0.12 m/year. These evolutions on the coast are, on the one hand, the result of manifestation of hydrodynamic factors and on the other hand, the intervention of the human factor by the strong urbanization of the shore and its anthropization. [9]

Evolution between 2003 and 2007 (4 years)

During a period of 4 years, our study area was marked by an alternation of erosion and accretion zone. Erosion has been triggered in the eastern sector and has been accentuated in the West sector with an average rate of -1.17m/year. We note that the accumulation zones are located in the same direction of the coastal with an average change of 2.73 m/year. These short-term changes are due to the combination natural and artificial factors, by the hydrodynamics and by the implantation of four T-shaped breakwaters which promote erosion downstream and progradation upstream of the coastal drift. [9]

Evolution between 2007 and 2012 (5 years)

From 2007 to 2012, erosion rates were significantly reduced to an average of -0.26 m/year. We notice the continuation of the fattening especially in the West sector with an average of 5.98m/year. The spectacular fattening in the West sector is caused by the beginning of the emplacement of a promenade and an artificial beach at Lido. [9]

Evolution between 2012 and 2018 (6 years)

During a period of 6 years, erosion started again in the eastern sector in upstream of the last breakwater and at the Lido with an average speed of -0.72 m/year. Progradation in the West sector continues with an average of 3.45 m/year. The phenomenal accretion in Lido Beach is artificial and is due to the artificial sand nourishment as well as the installation of an L-shaped breakwater to maintain it. [9].

Global evolution between 1980 and 2018 (38 years)

Analysis of the evolution of the study area over the medium term (38-year period) shows that our study area has gone through many changes. On the one hand, we note the formation of small beaches in pockets sheltered by the breakwaters which are fattening at an average speed of 0.8 m/year; this caused blocking of the sedimentary transit from the East to west as well as preventing the sediments from going offshore. On the other hand, there are small areas which are eroding at low rates of -0.51 m/year in the eastern sector downstream of the last right groyne of the Verte Rive as well as downstream from the promenade of Lido.

The analysis of surface changes is illustrated in the table 3. The general balance sheet of the evolution of surfaces in a period of 38 years is positive and estimated at 1490.133 m² with a gain of 61561.48 m² and a loss of -4936.439 m².

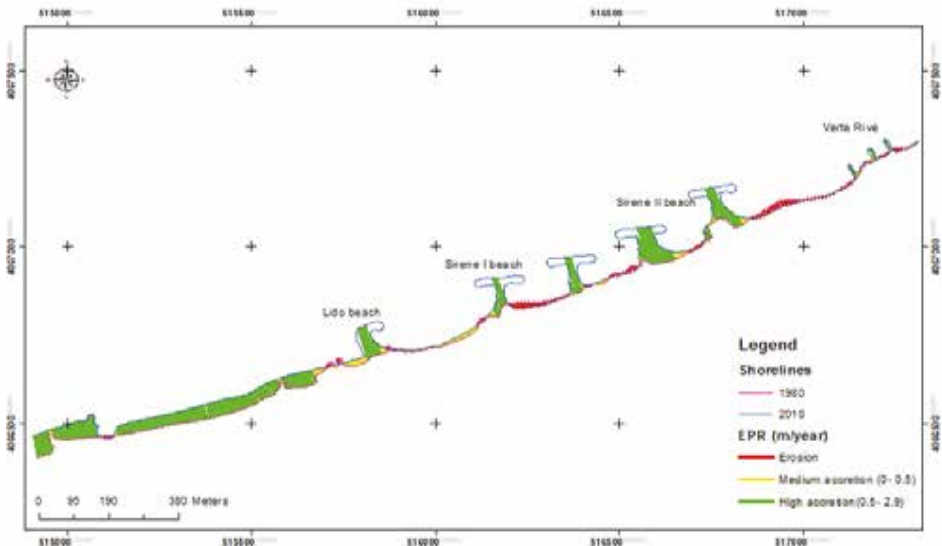

Figure 11 - Coastline evolution rates between 1980 and 2017.

Table 3 - Assessment of eroded and accumulated surfaces in the Bordj EL Kiffane area from 1980 to 2018.

Period	Accretion (m ²)	Erosion (m ²)	Balance (m ²)	Annual evolution (m ²)
1980-2003	8269.17	-9633.44	-1364.27	-59.32
2003-2007	26197.96	-6488.92	19709.03	4927.26
2007-2012	32924.74	-289.13	32635.62	6527.12
2012-2018	16153.77	-2766.31	13387.47	2677.49
1980-2018	61561.48	-4936.439	56625.04	1490.133

Conclusion

The Diachronic evolution of the coastline of Bordj El Kiffane area allowed determining its evolutionary rates and comparing the evolutions on different periods in absence and presence of the protection structures. The action of hydrodynamic factors with the strong anthropization of the shoreline and the construction of houses along the coastline of the area combined with human activities since 1980, have motivated the beginning of erosion and the retreat of the coastline. Besides, the implementation of various protection structures on the coastal area of Bordj El Kiffan has led to significant changes in the shoreline where there were high rates of accretion and low rates of erosion locally where accretion took the advantage over the retreat.

Finally, we can judge the impact of the protection structures on the city of Bordj El Kiffane as positive.

References

- [1] Salim, F.Z., El Habti, M.Y., Hamman, L.-H.K.B., Raissouni, A. and El Arrim, A. (2018) - *Application of a Geomatics Approach for the Diachronic Study of the Mediterranean Coastline Case of Tangier Bay*, International Journal of Geosciences, pp. 320-336.
- [2] Kadri I. (2017) - Impacts de l'implantation des ouvrages de protection sur la frange cotiere de Bordj El Kiffane. ENSSMAL 108 .
- [3] Benali H. And El Moutchou B. (2016) - *Evolution diachronique de la ligne de rivage et de l'occupation des espaces de la zone côtière de Ksar Esghir entre 1966 et 2005 (Tanger - Maroc)*, Innovative Space of Scientific Research Journals, International Journal of Innovation and Applied Studies, Vol. 16 No. 1. ISSN 2028-9324.
- [4] LEM (2009) - *Etude de protection du site de "Lido" commune de Mohammadia, Collecte et analyses des données de base*, Laboratory of Marine Studies, p. 79.
- [5] Zemenzer (2004) - Ensablement du port par transport sédimentaire simulation et application du modèle de Gao et Collins (1994) au port de Sidi Fredj. *Mémoire d'ingénieur* : ISMAL, pp. 6-7, 31-41.
- [6] Garcia C., *fortdeleau*. [Online] <http://www.fortdeleau.net>.
- [7] Samat O. (2007) - *Efficacité et impacts des ouvrages en enrochement sur les plages microtidales. Le cas du Languedoc et du Delta du Rhone*, Université d'Aix-Marseille I, Thèse de doctorat en Géographie physique et humaine, aménagement, urbanisme, 376.
- [8] Himmelstoss, E.A., Henderson, R.E., Kratzmann, M.G., and Farris, A.S. (2018) - *Digital Shoreline Analysis System (DSAS) version 5.0 user guide: U.S. Geological Survey Open-File Report 2018-1179*, 110. ISSN 2331-1258. <https://doi.org/10.3133/ofr20181179>.
- [9] Ismahane, KADRI, Cherif, Aoudj (2018) - *Conséquences de l'implantation des ouvrages de protection sur la frange côtière de Bordj El Kiffan (Algérie)*, La Rochelle : Editions Paralia CFL, DOI:10.5150/jngcgc.2018.017.

RELATIONSHIP BETWEEN SHORELINE EVOLUTION AND SEDIMENT WEAR

Isabel López¹, José I. Pagán¹, Antonio J. Tenza-Abril¹, Luis Aragonés¹, Luis Bañón¹

¹University of Alicante, Department of Civil Engineering, Carretera San Vicente del Raspeig s/n - 03690 San Vicente del Raspeig, Alicante (Spain),
phone +34 96 590 34 00, e-mail: lopez.ubeda@ua.es

Abstract – Many factors can influence the shoreline retreat, such as: the maritime climate, anthropogenic actions like the construction of ports, dams, etc. To overcome this problem, it is necessary to understand the influence of each of the factors involved in beach erosion. This work tackles the problem of shoreline erosion from the study of the beach material, specifically sediment wear. The main objective is to establish a relationship between shoreline evolution and sediment wear. The study of diverse beaches (with different median sediment size, mineralogical composition, etc.) shows that the shoreline evolution trend is similar to of the results obtained by the accelerated particle wear test (APW). However, the relationship between the number of APW test cycles and the years of shoreline evolution is not clear. In Guardamar beach (Guardamar, Spain) the ratio (years/cycles) is 9.7, in Marineta Casiana beach (Denia, Spain) it is 5.6, and in Arenal beach (Calpe, Spain) it is 3. Differences may be due to the different mineralogical composition and morphology of the sand particles. Therefore, there is a relationship between sediment wear and shoreline evolution. However, more sediment tests (composition, morphology, fractures, etc.) are needed to determine the exact relationship between the number of APW cycles and the years of shoreline evolution.

Introduction

Coastal erosion is one of the most important problems worldwide [7]. Many actions have been undertaken to try to solve this problem, all of them based on two main aspects: the construction of protection structures and the supply or dumping of sediment [9, 38]. Periodic beach nourishment is considered to be the most acceptable method of protecting and stabilising beaches and restoring dunes [3, 14, 23]. However, to stop coastal erosion it is necessary to know the factors involved in the retreat of the shoreline, such as the waves, currents, the properties of the sediments, and the conditioning factors of the environment [6].

According to various authors, the intrinsic factors that control the stability of beaches are the profile of the beach and the characteristics (size, density and porosity) of the sediments [1, 29, 35]. Therefore, sediments are an important part of understanding coastal processes [12]. Many authors relate shoreline changes to sediment movements, specifically between the shoreline and the depth of closure [10, 13, 37], while others indicate that sediment wear is an important factor in shoreline evolution [8, 32, 33].

Sediment wear begins when the particles that constitute the sediment are set in motion, that is, when the instantaneous force of the fluid is greater than the resistance force of the grain [36]. Once the particles are in motion, wear can be caused by three phenomena [20]: i) particle shock. ii) Dissolution of carbonates. iii) Breakage and separation of mineral

fractions. Therefore, it is clear that the mineralogical composition of the sediment is an important factor to consider in wear [34]. However, according to several authors, the most influential factors in sediment wear are the morphology and fatigue of the material [21, 32]. Fatigue is understood as the breakage of the material when it is submitted to long-duration dynamic efforts, or the tendency to fail due to cyclic loads [4, 5]. Cyclic loads often cause failure in brittle materials, such as rocks, with stress levels below their strength under monotonous conditions [4, 11]. The existence of fractures and other microstructural aspects (microcracks, pores, etc.) in rocks significantly affect their fatigue strength [16, 18, 19].

Therefore, it is known that the sediment is worn by breakage when the particles collide with each other, by the dissolution of the mineral elements that compose it and by the fractures and micro-fissures of the particles [20, 21, 32]. However, the degree of influence that sediment wear has on beach erosion is not known. For this reason, this study will analyse the evolution of the shoreline, the maritime climate and the wear of sediment on 3 beaches to establish a relationship between beach erosion and sediment wear.

Materials and Methods

Shoreline evolution

The evolution of the shoreline was carried out by studying aerial images from 1956 to 2019. The non-georeferenced images (years 1956, 1977, 1981, 1986, 1990, 1992, 1994, 1996, 1998) were georeferenced using ArcGIS 10.1® software. Both non-georeferenced and orthophotos (years 2000, 2005, 2007, 2009, 2012, 2014) were obtained from the CNIG (Spanish National Centre of Geographic Information, www.cnig.es) under CC-BY 4.0 license.

Once the orthophotos of each year were obtained, the vectorization of the shoreline was performed. The criterion for digitizing the shoreline was the choice of the line of the last wet tide mark on the beach profile [28, 30]. Given the high resolution of the aerial images, the digitisation was conducted at a scale of 1:1000, which allows the shoreline to be obtained visually in detail. To obtain the width of the beach in each period, transects were created perpendicular to the shoreline every 100 m. The intersection of these transects with the shoreline allows obtaining the different beach widths.

To compare the results of the evolution of the shoreline with the wear of the sediment, the anthropic actions and the nourishment performed on the different beaches were considered. The beginning of the evolution of the shoreline was chosen as the year after the beach nourishment since this coincides with the material that was tested for wear.

Maritime climate

To exclude the influence of waves on the evolution of the shoreline, the maritime climate on each of the beaches was studied using data from the SIMAR nodes nearest to each of them. The data of the SIMAR series provided by Puertos del Estado (<http://www.puertos.es>), have been collected over 61 years, during the period 1958-2019, which constitutes the most complete database of the Mediterranean.

These data were treated using the AMEVA v1.4.3 software [15], obtaining for each of the study periods, the significant wave height and its corresponding periods, directions and probabilities of occurrence.

Sediment wear

The accelerated particle wear test (APW) proposed by López [20]. In this test, 75 g of sand from the beach and 500 ml of seawater from the study area are poured into a magnetic stirrer at 1600 rpm in 24-hour cycles. After each test cycle, the granulometry of the sand sample (UNE 103 101:1995, UNE 7050-2 and UNE 103 100) and the calcimetry of the water were performed using the Bernard calcimeter method (UNE 103200-93). The test is terminated when more than 50 % of the sample presents sizes smaller than 0.063 mm.

Finally, the Scanning Electron Microscopy (SEM) was used to perform elemental and morphological analysis of the sediments. This technique allows obtaining images of the sample, as well as the elemental composition of the sample and its possible changes [24].

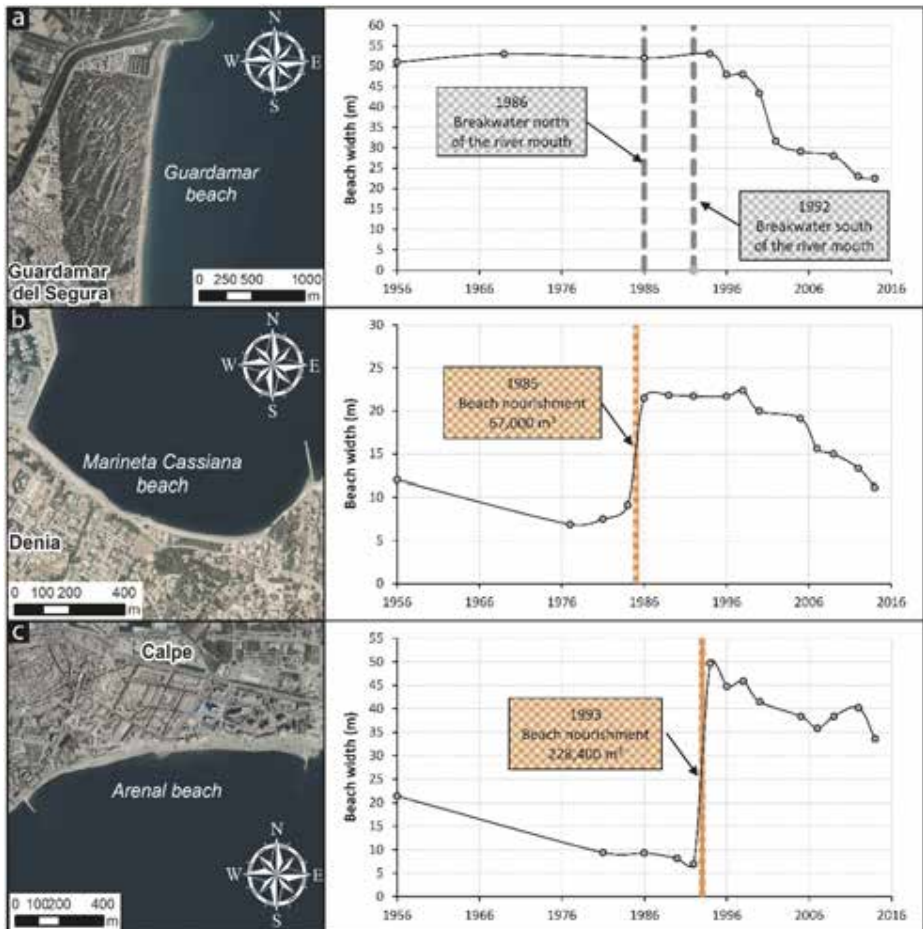

Figure 1 - Location of study beaches and evolution of the mean beach width. a) Guardamar. b) Marineta Casiana. c) Arenal.

Thus, it was possible to know the microstructure and morphology of the particles with their possible fracture faces and heterogeneity. For crystallographic analysis, X-ray diffraction (XRD) was used to determine their mineralogical composition.

Results

Figure 1 shows the evolution of the mean width of the beaches since 1956. All three beaches show clear erosion. Erosion on Guardamar beach began just after the construction of the groins at the mouth of the Segura river. Since then, more than 30 m were lost in 20 years (58 % of the beach). In Marineta Casiana and Arenal, beach nourishments were performed in 1985 and 1993, respectively. The nourishment at Marineta Casiana with 67 000 m³ of sand produced an increase in beach width of 12.4 m. And the nourishment in the Arenal with 228 400 m³ produced an increase of 42.8 m in width. Erosion on these two beaches continued after the nourishment, with a rate of -0.37 m/year at Marineta Casiana and -0.8 m/year at Arenal. Due to the nourishment conducted, for this study data on the evolution of the coast since 1956 in Guardamar, 1986 in Marineta Casiana, and 1994 in the Arenal are used. This is done so that the material tested in the APW test is related to the existing material on the beach.

To justify that the increase in erosion in recent years, especially on the beaches of Guardamar and Marineta Casiana, is not related to the waves, Figure 2 shows the evolution of the average wave height (Hm) and its associated period (Tm) on each of the beaches under study. Thus, in Guardamar, the mean wave height remains constant at an average of 0.6 m and a period of 5.3 s. At Marineta Casiana, due to its orientation (NNE), the mean wave height at the beach is higher than at the other beaches, but although the height is greater, the mean height is also constant, with an average of 0.76 m and a period of 6.2 s. The Arenal beach is where the lowest wave height occurs because it has a south orientation. The mean wave height is 0.55 m and a period of 5 s. On this beach, a small increase in the mean wave height is observed in the years 2013 and 2014, with wave height values of 0.7 m and 0.65 m, respectively.

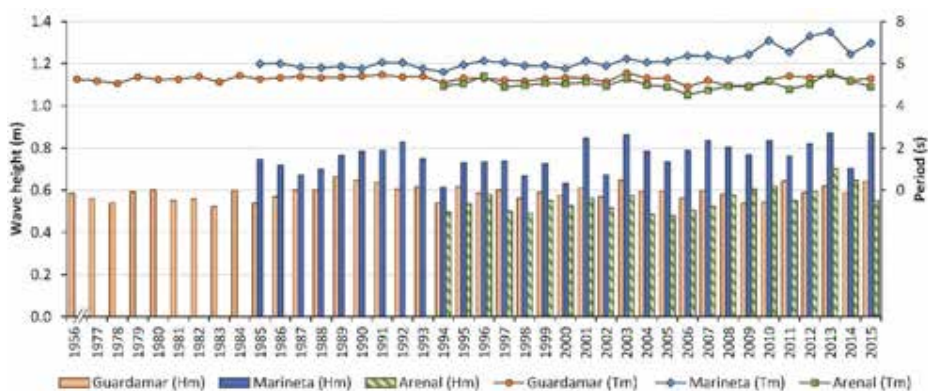

Figure 2 - Evolution of mean wave height and its associated period on each of the study beaches.

The next step is to compare in the APW test and the percentage of beach width lost from, as indicated above, the year of origin of the data (Guardamar) or from the nourishments conducted on the beach (Marineta Casiana and Arenal). As shown in Figure 3, the results of the APW test are completely different on the three beaches. Guardamar beach takes 6 cycles to lose 50 % of its mass, while Marineta Casiana beach takes 5 cycles and Arenal beach 7 cycles. Nor the mode of wear is the same, while the Arenal wears continuously and linearly, the beaches of Guardamar and Marineta Casiana have continuous wear until a cycle in which they lose material abruptly. This behaviour is similar to the behaviour of the evolution of the average beach width. However, the relationship between the number of years and the number of cycles in the APW test is completely different between the three beaches. For Guardamar beach the ratio (years/cycles) is 9.7, in Marineta Casiana it is 5.6, and in Arenal it is 3. This difference in sediment behaviour compared to the APW test and in the years/cycles ratio could be due to the different mineralogical composition and morphology of the particles (Figure 4).

The mineralogical composition of the sediment is similar on the beaches of Marineta Casiana and the Arenal, where the main component is quartz (> 60%) and the next mineral is Calcite. However, the composition at Guardamar beach is mainly distributed in Quartz, Calcite and Dolomite. The morphology of the particles on the three beaches is also different. Particles from Guardamar beach present angular shapes at the edges, foliation planes and a large number of fissures, while the particles from Marineta Casiana and Arenal show more rounded edges. Besides, the Marineta Casiana particles show Calcium and Silicon clusters.

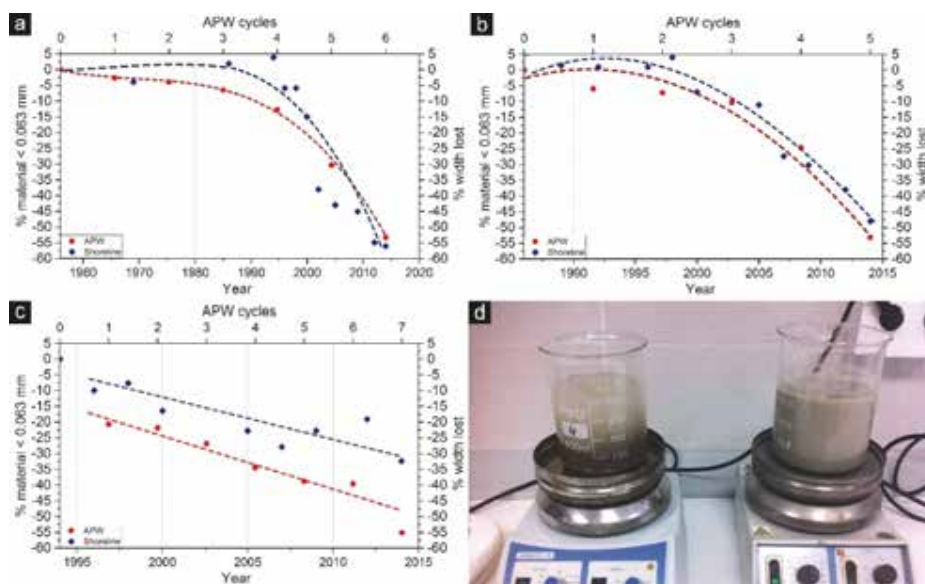

Figure 3 - Percentage of material less than 0.063 mm at the end of each cycle and percentage of mean width lost. a) Guardamar. b) Marineta Casiana. c) Arenal. d) APW test.

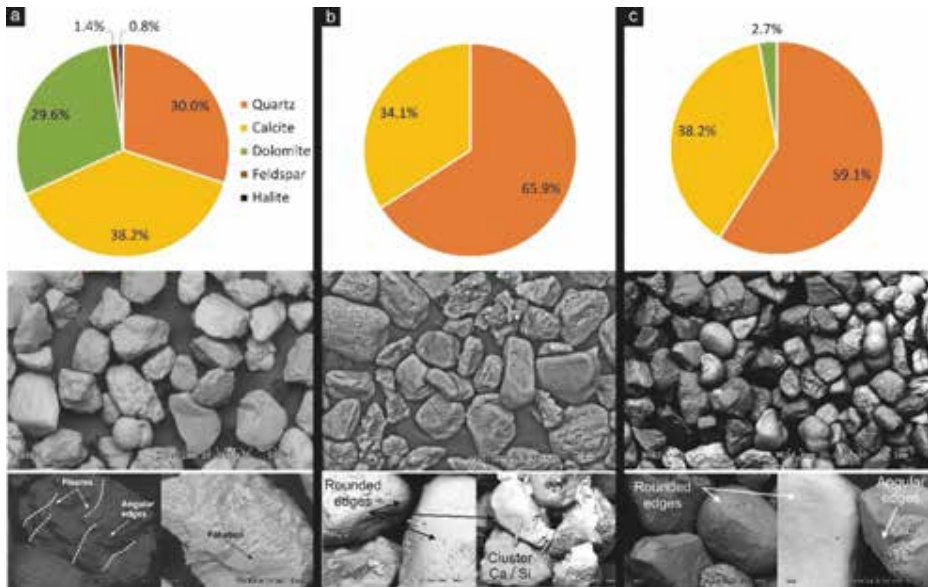

Figure 4 - Mineralogical composition and morphology. a) Guardamar. b) Marineta Casiana. c) Arenal.

Discussion

Coastal erosion is a major problem that has worsened in recent years. One element that could explain this increase in erosion is that wave energy and frequency have increased in recent years due to climate change [27]. However, as shown in Figure 2, wave conditions in the study areas have hardly changed, which coincides with those observed by other authors in the same or nearby areas [8, 31-33]. So why is erosion increasing? According to several authors, this increase could be due to the durability (ageing) of the beach material [22, 25].

In this sense, the durability of the material would be related to its mineralogical composition and the morphology of its particles. From the images obtained from microscopy, it can be seen that there is an important difference in the number of rounded and homogeneous particles. Thus, Marineta Casiana presents clusters of Silicon and Calcium, that is, weak unions between the minerals which could lead to the separation of the two mineral phases and the consequent loss of size [20]. Guardamar beach, however, with a large number of fissures and exfoliation planes, is the one which lasts the longest if the number of years it has been on the beach is considered (since 1956). This could be explained by the presence of dolomite which presents greater resistance to minerals such as quartz or calcite [17]. Thus, it is clear that the durability of materials is completely different depending on their composition and therefore they behave differently to the atmospheric conditions, which on a beach leads to different behaviours in the evolution of the shoreline [32]. And so, by accepting the hypothesis of the durability of beach sediment, the acceleration of beach erosion in recent decades can be explained since the amount of natural contributions to the

sea (and consequently to the beach) has been reduced due to the construction of dams and channels [2, 26].

The aforementioned implies that there is a relationship between sediment wear and the erosion of the shoreline. It is also shown that, as explained by other authors [8, 22, 32, 33] sediment wear is mainly influenced by the mineralogical composition and the morphology of the particles. These latter factors need to be studied in more detail to finally determine the relationship between the number of cycles in the APW test and the years of coastal erosion.

Conclusion

There is a relationship between sediment wear and the shoreline evolution. However, more sediment tests (composition, morphology, fractures, etc.) are needed to determine the exact relationship between the number of APW cycles and the years of shoreline evolution.

Acknowledgements

This research has been funded by the Generalitat Valenciana through the project GV/2019/017 (Estudio sobre el desgaste y composición de los sedimento y su influencia en la erosión de las playas de la Comunidad Valenciana).

References

- [1] Anfuso G., Martínez J.A., Gracia F.J. (2001) - *Longshore distribution of morphodynamic beach states in a homogeneous coast in SW Spain*, Proceedings of the 5th MEDCOAST: Mediterranean Coast Environment, Hammamet, Tunisia, 23-27 October 2001, Volume 3, pp. 1381-1392.
- [2] Aragonés L., Pagán J.I., López M.P., García-Barba J. (2016) - *The impacts of Segura River (Spain) channelization on the coastal seabed*, Science of The Total Environment. 543, Part A, 493 - 504.
- [3] Aragonés L., Serra J.C., Villacampa Y., Saval J.M., Tinoco H. (2016) - *New methodology for describing the equilibrium beach profile applied to the Valencia's beaches*, Geomorphology. 259, 1 - 11.
- [4] Attewell P.B., Farmer I.W. (1973) - *Fatigue behaviour of rock*, International Journal of Rock Mechanics and Mining Sciences & Geomechanics Abstracts. 10 (1), 1 - 9.
- [5] Bagde M.N., Petroš V. (2005) - *Fatigue properties of intact sandstone samples subjected to dynamic uniaxial cyclical loading*, International Journal of Rock Mechanics and Mining Sciences. 42 (2), 237 - 250.
- [6] Bardají T., Zazo C., Cabero A., Dabrio C.J., Goy J.L., Lario J., Silva P.G. (2009) - *Impacto del cambio climático en el litoral*, Enseñanza de las Ciencias de la Tierra. 17 (2), 141 - 154.
- [7] Bird E. (2011) - *Coastal geomorphology: an introduction*, 2nd ed., John Wiley & Sons, England.

- [8] Chiva L., Pagán J.I., López I., Tenza-Abril A.J., Aragonés L., Sánchez I. (2018) - *The effects of sediment used in beach nourishment: Study case El Portet de Moraira beach*, Science of The Total Environment. 628-629, 64 - 73.
- [9] Dean R.G. (2003) - *Introduction to Coastal Processes*, Cambridge University Press. 162 - 203.
- [10] Demarest J.M., Kraft J.C. (1987) - *Stratigraphic record of quaternary sea levels: implication for more ancient strata*, Sea-level Changes and Coastal Evolution, SEPM Society for Sedimentary Geology, Tulsa, United States. 41, 223 - 239.
- [11] Erarslan N., Williams D.J. (2012) - *Experimental, numerical and analytical studies on tensile strength of rocks*, International Journal of Rock Mechanics and Mining Sciences. 49, 21 - 30.
- [12] Guillén J., Jimenez J.A. (1995) - *Processes behind the longshore variation of the sediment grain size in the Ebro Delta coast*, J Coastal Res. 11 (1), 205 - 218.
- [13] Hallermeier R.J. (1980) - *A profile zonation for seasonal sand beaches from wave climate*, Coast Eng. 4, 253 - 277.
- [14] Hanson H., Brampton A., Capobianco M., Dette H., Hamm L., Laustrup C., Lechuga A., Spanhoff R. (2002) - *Beach nourishment projects, practices, and objectives—A European overview*, Coast Eng. 47 (2), 81 - 111.
- [15] IHCantabria. (2013) - *Análisis Matemático y Estadístico de Variables Medioambientales (AMEVA)*, Universidad de Cantabria: Cantabria, Spain. Available online: <http://ihameva.ihcantabria.com/>.
- [16] Justo-Reinoso I., Srubar W.V., Caicedo-Ramirez A., Hernandez M.T. (2018) - *Fine aggregate substitution by granular activated carbon can improve physical and mechanical properties of cement mortars*, Construction and Building Materials. 164, 750 - 759.
- [17] Kushnir A.R.L., Kennedy L.A., Misra S., Benson P., White J.C. (2015) - *The mechanical and microstructural behaviour of calcite-dolomite composites: An experimental investigation*, Journal of Structural Geology. 70, 200 - 216.
- [18] Li A., Draine B.T. (2001) - *On ultrasmall silicate grains in the diffuse interstellar medium*, Astrophysical Journal. 550 (2 PART 2), L213 - L217.
- [19] Liu Y., Dai F., Xu N., Zhao T., Feng P. (2018) - *Experimental and numerical investigation on the tensile fatigue properties of rocks using the cyclic flattened Brazilian disc method*, Soil Dynamics and Earthquake Engineering. 105, 68 - 82.
- [20] López I., López M., Aragonés L., García-Barba J., López M.P., Sánchez I. (2016) - *The erosion of the beaches on the coast of Alicante: Study of the mechanisms of weathering by accelerated laboratory tests*, Science of The Total Environment. 566–567, 191 - 204.
- [21] López M., Baeza-Brotons F., López I., Tenza-Abril A.J., Aragonés L. (2018) - *Mineralogy and morphology of sand: Key parameters in the durability for its use in artificial beach nourishment*, Science of The Total Environment. 639, 186 - 194.
- [22] López M., Baeza-Brotons F., López I., Tenza-Abril A.J., Aragonés L. (2019) - *Factors influencing the rate of beach sand wear: Activation layer thickness and sediment durability*, Science of The Total Environment. 658, 367 - 373.
- [23] Magoon O.T., Edge B.L., Ewing L. (2001) - *Sustainable beaches: where do we go from here? What should we be doing to reduce erosion threat to the nation's coastline?*, Proceedings of the 14th annual National Conference on Beach

- Preservation Technology, Orlando, Florida, United States, 7-9 February 2001, Volume 1, pp. 22-38.
- [24] Melgarejo J.C., Proenza J.A., Galí S., Llovet X. (2010) - *Técnicas de caracterización mineral y su aplicación en exploración y explotación minera*, Boletín de la Sociedad Geológica Mexicana. 62 (1), 1 - 23.
- [25] Michalowski R.L., Wang Z., Park D., Nadukuru S.S. (2018) - *Static fatigue or maturing of contacts in silica sand*, Proceedings of the 4th GeoShanghai International Conference, Shanghai, China, 27-30 May 2018, Volume, pp. 911-918.
- [26] Newton A., Carruthers T.J.B., Icely J. (2012) - *The coastal syndromes and hotspots on the coast*, Estuar Coast Shelf S. 96, 39 - 47.
- [27] Nováčková M., Tol R.S.J. (2018) - *Effects of sea level rise on economy of the United States*, Journal of Environmental Economics and Policy. 7 (1), 85 - 115.
- [28] Ojeda J., Fernández M., Prieto A., Pérez J.P., Vallejo I. (2010) - *Levantamiento de líneas de costa a escalas de detalle para el litoral de Andalucía: criterios, modelo de datos y explotación*, Proceedings of the XIV Congreso Nacional de Tecnologías de la Información Geográfica, Sevilla, Spain, 13-17 September 2010, Volume 77, pp. 324-336.
- [29] Oliveira S., Moura D., Horta J., Nascimento A., Gomes A., Veiga-Pires C. (2017) - *The morphosedimentary behaviour of a headland–beach system: Quantifying sediment transport using fluorescent tracers*, Mar Geol. 388, 62 - 73.
- [30] Pagán J.I., Aragonés L., Tenza-Abril A.J., Pallarés P. (2016) - *The influence of anthropic actions on the evolution of an urban beach: Case study of Marineta Cassiana beach, Spain*, Science of The Total Environment. 559, 242 - 255.
- [31] Pagán J.I., López I., Aragonés L., Garcia-Barba J. (2017) - *The effects of the anthropic actions on the sandy beaches of Guardamar del Segura, Spain*, Science of The Total Environment. 601, 1364 - 1377.
- [32] Pagán J.I., López M., López I., Tenza-Abril A.J., Aragonés L. (2018) - *Causes of the different behaviour of the shoreline on beaches with similar characteristics. Study case of the San Juan and Guardamar del Segura beaches, Spain*, Science of The Total Environment. 634, 739 - 748.
- [33] Pagán J.I., López M., López I., Tenza-Abril A.J., Aragonés L. (2018) - *Study of the evolution of gravel beaches nourished with sand*, Science of The Total Environment. 626, 87 - 95.
- [34] Roberts J., Jepsen R., Gotthard D., Lick W. (1998) - *Effects of particle size and bulk density on erosion of quartz particles*, Journal of Hydraulic Engineering. 124 (12), 1261 - 1267.
- [35] Román-Sierra J., Muñoz-Perez J.J., Navarro-Pons M. (2014) - *Beach nourishment effects on sand porosity variability*, Coast Eng. 83, 221 - 232.
- [36] Shields A. (1936) - *Application of similarity principles and turbulence research to bed-load movement*, California Institute of Technology, Pasadena, California, United States.
- [37] Stauble D., Cialone M. (1997) - *Sediment Dynamics and Profile Interactions: DUCK94*, Proceedings of the 25th International Conference on Coastal Engineering, Orlando, Florida, United States, 2-6 September 1996, Volume 1, pp. 3921-3934.
- [38] Trembanis A.C., Pilkey O.H. (1998) - *Summary of beach nourishment along the US Gulf of Mexico shoreline*, J Coastal Res. 14 (2), 407 - 417.

EXPERIENCES WITH BEACH NOURISHMENTS ON THE COAST OF ALICANTE, SPAIN

José Ignacio Pagán¹, Isabel López¹, Luis Aragonés¹, Antonio J. Tenza-Abril¹

¹University of Alicante, Department of Civil Engineering, Carretera San Vicente del Raspeig s/n -
03690 San Vicente del Raspeig, Alicante (Spain),
phone +34 96 590 34 00, e-mail: jipagan@ua.es

Abstract – The historical evolution of sandy beaches on the coast of Alicante (Spain) has been analysed from aerial images from 1956 to 2019. The beach nourishments carried out in the 1990s to avoid coastal damages and to improve the touristic offer were studied. Shoreline evolution and beach surface has been obtained using GIS. The change of the sediment composition, from gravel to sand, due to the fills has caused a relevant imbalance. Beach nourishments failed its main aim of avoiding the shoreline erosion, causing environmental damages to the nearby *Posidonia oceanica* meadows.

Introduction

Coastal erosion is a worldwide problem. This issue is the result of multiple factors, such as the lack of sediment supply, climate change or anthropic actions that change the littoral morphodynamic [16]. Over the last few decades, there has been a gradual shift in coastal defence techniques, tending in recent years to soft actions such as the nourishment of sandy beaches as an erosion mitigation mechanism [7]. The placement of sand on the beach is considered the most acceptable form of coastal stabilization [5, 8]. However, it is important to be aware of the effects of the anthropic actions carried out in the past to project future coastal works [1, 2, 4, 17, 22, 23].

The analysis of the historical shoreline evolution has a key role in coastal studies [9]. Historically, the drawing of the coastline has been an arduous task with important methodological and technical limitations, but at present the use of Geographical Information Systems (GIS) has meant a great advance in this field, as it integrates various data sources (cartography, aerial or satellite images) that make it possible to obtain and compare the evolution of the shoreline over time [18, 19].

Another important aspect in the study of the evolution of the shoreline is to know the sediment characteristics. Changes in the typology of the sediment that conforms the beach can lead to unsuccessful nourishment projects. Gravel beaches transformed into sandy ones caused permanent instability on the shoreline (originally stable) [4, 17, 23].

In this research, the historical evolution of 3 beaches on the coast of Alicante, (Spain) have been studied. The beaches of Guardamar del Segura, Calpe (Arenal beach) and Dénia (Marineta Cassiana beach) were selected due to its interest. These beaches were nourished in the 1990s, changing in the last two the sediment type from gravel to sand [23]. The aim of this research is to analyse the evolution of the nourishments, studying the shoreline movements and relating it with the sedimentary composition of the beaches.

Materials and Methods

Our research has studied sandy beaches located on the Spanish Mediterranean coast, in the province of Alicante (Spain), whose main characteristics are described in Table 1. The location of these beaches along the coast is representative of the diverse environments in which they are situated: from long natural beaches with dune ridges to beaches in totally regenerated urban environments. In addition, these beaches have different exposures to incident waves, although most are oriented to the east, as is usual on the eastern Spanish Mediterranean coast. Their location is presented in Figure 1.

Table 1 - Characteristics of the studied beaches.

Beach	Municipality	Length (km)	D50 (mm)	Coast	Promenade
Marineta	Dénia	1.20	0.370	Urban	Yes
Cassiana					
Arenal	Calpe	1.37	0.260	Urban	Yes
Viveros	Guardamar del Segura	1.40	0.244	Dunes	No

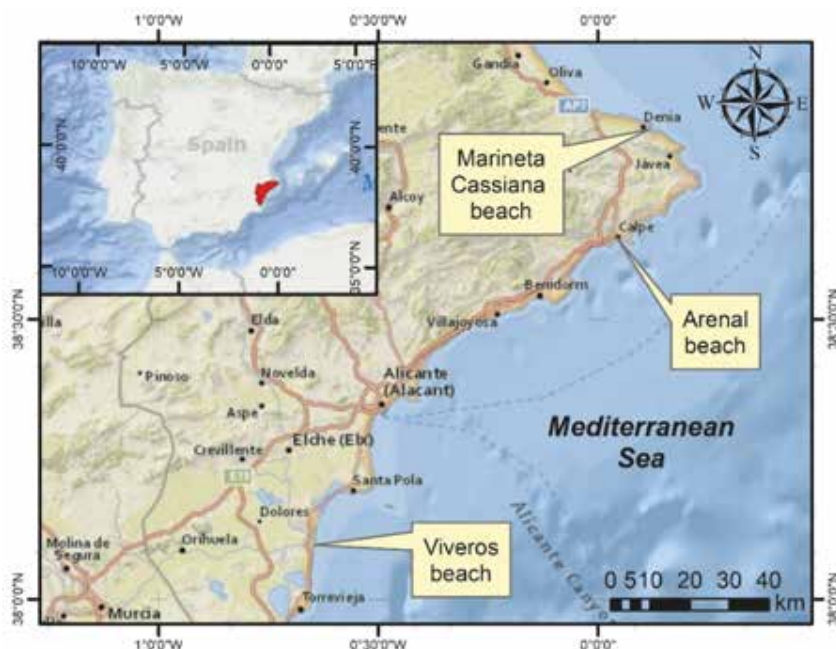

Figure 1 - Location of the beaches in the province of Alicante (Spain).

Aerial imagery covering a period from 1956 to 2019 were used to analyse the beach evolution. Data from 1956 and 2000 to 2019 were available in georeferenced orthomosaics

in ECW format, in GCS UTM ETRS89 H30N. However, images from 1977 to 1998 were only in digital format, non-georeferenced. Thus, the first step was to georeference these images and create a GeoTIFF orthomosaic for each period. This task was performed using a Geographic Information System (GIS), in particular ArcGIS 10.5® software. Both non-georeferenced images and orthophotos were obtained from the PNOA website (National Plan for Aerial Orthophotography, <https://pnoa.ign.es/>). The spatial resolution of the datasets ranges from 1 m/pixel for the mosaics from 1956 to 1998, 50 cm/pixel for 2000 and 2005 images and 0.25 cm/pixel for the rest, from 2007 to 2019. This spatial resolution is high enough in all datasets to identify the shoreline.

The shoreline was vectorized for each period from the orthomosaics available. The vectorization process consists of the visual identification of the last wet mark on the beach, marking this line as the shoreline. All available images were taken in summer and with a relatively calm sea state, so the vectorized line is suitable for comparative study in time. The backshore surface was delimited by the polygon formed by the shoreline and the promenade or dune toe. Overlapping these layers from different periods, erosion or accretion areas were calculated, and thus the sediment budget was inferred. Perpendicular transects spatially separated 100 m were created to measure beach width changes. In addition, the bathymetry, sediment grain size distribution and seabed morphology have been studied by means of spatial analysis techniques in a GIS environment.

Results

Marineta Cassiana beach was nourished with sand in the 90s, reaching an average width of 27 from its initial width of 9 m. Since then, it has suffered erosion at rates of 1 m/year almost disappearing in some points of the beach. The nourishment changed the beach sediment typology, from gravel to sand.

The beach evolved from having an average width of 12 m in 1956 to a minimum of 7 m in 1984 (Figure 2a), with some sections of the beach with less than 2 m width. The contribution of material nourished the beach widths of the 1950s, and was especially important in the eastern part of the beach, where under the shelter of the new jetty the width of the beach increased from 6 m in 1986 to 52 m in 1992. However, in this area the beach suffers a relevant erosion losing practically all the surface gained, becoming its width non-existent since 2014.

This continuous erosion in time, with a negative trend of its surface (a loss of 60 %) is only reverted by the anthropic actions of beach nourishments (Figure 2b). Noteworthy were the fills with 67 000 and 25 500 m³, which, when transformed into beach area, represents 25 830 and 12 750 m² respectively. However, from then until now the erosive trend of the beach has been maintained, having in 2018 a surface area of 11 500 m², similar to the minimum of 9 400 m² obtained in 1984, prior to the two consecutive nourishments. Moreover, *P. oceanica* meadow located close to the beach was flooded during the fills.

The beach of Arenal (Calpe) has suffered a series of anthropic actions that have modified its morphology, from being historically a gravel beach to become a beach of medium sands today. In 1993, it was nourished with 228 400 m³ of sand. In addition, to support and guarantee the beach stability, two breakwaters were built. Both breakwaters point slightly into the interior of the beach, and they are semi-submerged in their outermost half to

cause less visual impact and to facilitate the renewal of water. In 2007, the beach was nourished with 31 500 m³ of sand of the same median size as the existing one.

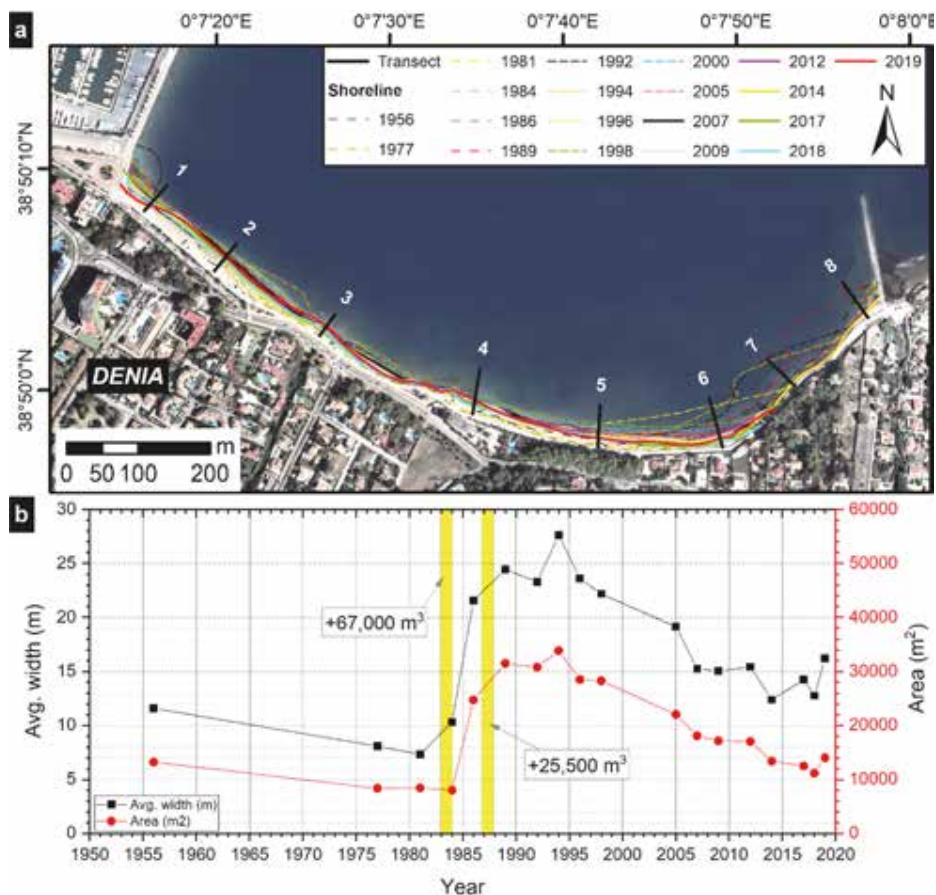

Figure 2 - (a) Shoreline evolution from 1956 to 2019 for Marineta Cassiana beach (Dénia), with location of transects. (b) Beach area and average width, with nourishments noted.

A surface increase immediately after the nourishments is detected, but the erosion trend continues afterwards. In 1992 the width of the beach was zero in a stretch of 500 meters long, in its central position. The 1993 nourishment meant an increase in the average width of 50 m. However, from that moment until 2005 the erosion rates of -1.3 m/year make the beach continue in regression. Since the second contribution in 2007, the beach has shown a stable trend, except in its western part where erosion is detected next to the breakwater. The beach area passed from a minimum of 20 000 m² to its maximum after the nourishment of 1993, when it reached 70 000 m². Since 2007 the beach surface is stabilized in 53 000 m².

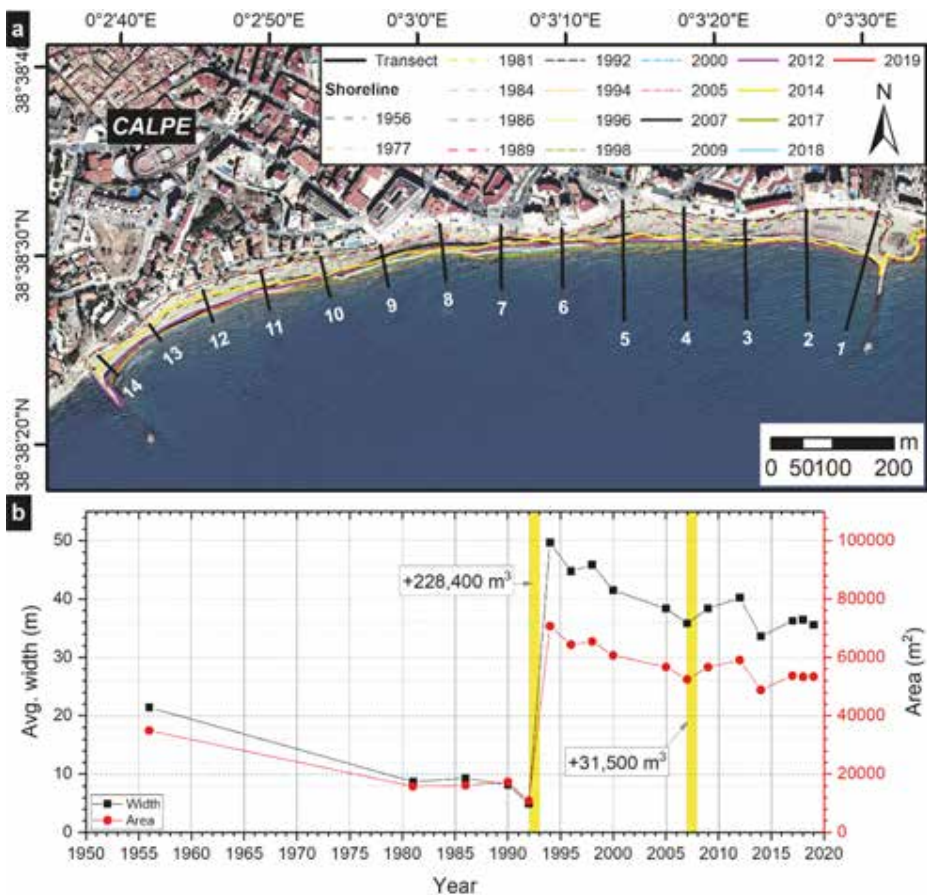

Figure 3 - (a) Shoreline evolution from 1956 to 2019 for Arenal beach (Calpe), with location of transects. (b) Beach area and average width, with nourishments noted.

Arenal beach maintains its profile once the equilibrium beach profile was reached after the nourishment of 1993. The depth of closure is located at 330 m from the coast and 7.75 m depth. The *P. oceanica* meadow was located at 6 meters depth, so is in the active onshore zone. This caused that the sediment filled the *P. oceanica*. The disappearance of this high-environmental asset and natural reef is an undesired effect of the nourishment.

Viveros beach (Guardamar del Segura) was historically stable due to longitudinal north-south transport, with a surface of ~240 000 m² and average width of 65 m. This trend continued until 1986, when groynes were built to prevent the river mouth from silting. In 1990 the shoreline retreated 20 m, recovering 50 m (+14 000 m²) in the following period (1990-1992) due to the fill using the sediment dredged from the river channel. The sand dumped at this point was a silty/clayey sand, so it was quickly displaced by the waves, losing in the period 1992-1994 about 30 m of beach width. In 1998 a marina was also built and the dredge material was

verted to form an artificial dune. From that moment, erosion has been increased, reaching values of 3 m/year and thus causing that during the storms the waves reach the dune ridge, eroding it. The relation between dune and beach erosion rates was 2.3. The slight increase in surface detected in 2017 is at the expense of the erosion of the artificial dune ridge, which has lost 20 m width since it was created in 1998. At present (2019) beach width is at minimum values in almost all transects.

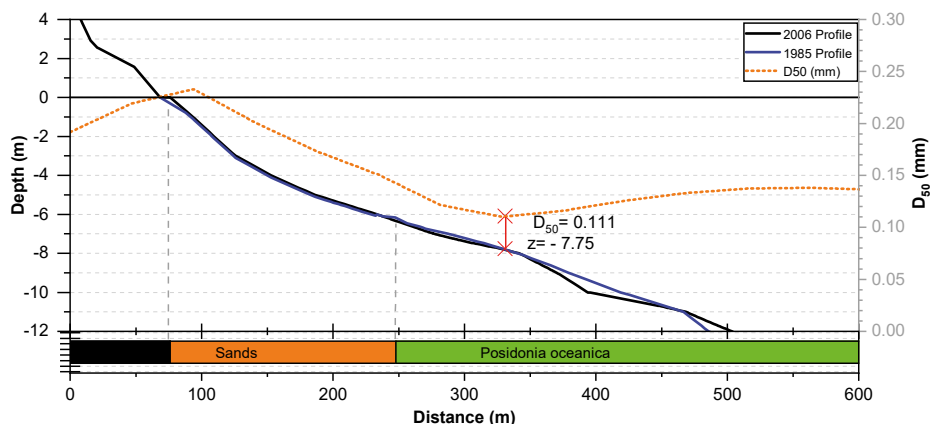

Figure 4 - Beach profile prior and after nourishment of Arenal beach (Calpe) and median sediment size distribution, with depth of closure marked.

Discussion

The urban growth due to the mass tourism [21], the continuous construction of marinas and commercial ports, promenades and groynes had an extraordinary impact on the Mediterranean coasts [2, 11, 20]. Therefore, governments should provide solutions, such as beach nourishment for protection against erosion [13].

This research has studied three nourished beaches in the south east of Spain in the 1990s. Its interest relies on the time passed since the fills were carried out (30 years) and the fact that two beaches (Marineta Cassiana and Arenal beaches) changed its natural sediment type from gravel to sands with the aim of increase its tourist attraction [17].

Establishing the sedimentary budget of a beach is fundamental. The availability of photogrammetric surveys allows the analysis of the shoreline evolution using GIS techniques [1]. For this research, aerial images from the last 63 years were used to monitor the shoreline evolution of the selected beaches, successfully obtaining the shoreline evolution (Figure 2, 3 and 5) and enabling the measurement of the evolution of the anthropic actions carried out.

The results have shown that: i) There is a continuous loss of sand on the beaches analysed, with erosion rates after anthropic actions even worse than previous ones. (ii) The coastal defence system based on fills do not contain the projected beach width in the long term, and (iii) The nourishment design must be improved to avoid affecting the nearby marine flora and fauna.

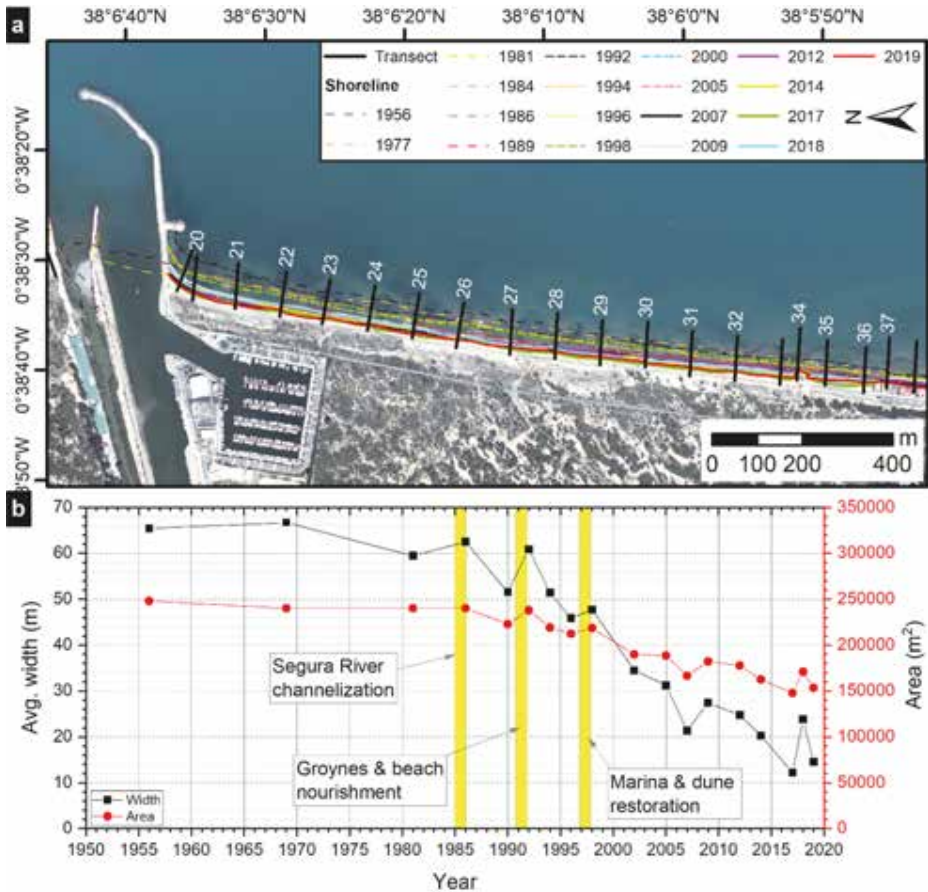

Figure 5 - (a) Shoreline evolution from 1956 to 2019 for Viveros beach (Guardamar del Segura), with location of transects. (b) Beach area and average width, with anthropic actions noted.

A nourishment might cause alarm on public opinion, among other things, because of the initial width in the first years, or the possible environmental damage that the turbidity of the water might cause due to the new material used for the beach nourishment [4]. In Marineta Cassiana beach, *P. oceanica* meadow located close to the beach was flooded during the fills, causing its loss and probably incrementing the erosion rates detected.

Many works can be found where the essential aspects for the design of beach nourishment are described [3, 6, 10, 12]. However, a very important factor, such as the used sediment to feed the beach has been less studied, although there are studies on nourishments that indicate that for example the density of sediment influences much more than size in the longevity of a beach nourishment [24]. The use of inappropriate sediment to execute the nourishments may be the reason of its poor results. It is essential for a coastal engineer to

have mineralogical and morphologic studies before taking any decision before any beach nourishment, since any change in its typology or its characteristics may produce an unsuccessful nourishment, such as the examples shown in this research. The study of the mechanisms of weathering by accelerated laboratory tests [14, 15] could be the solution to establish the relationship between sediment wear and erosion of the shoreline in future beach nourishments designs.

Conclusion

The change of the sediment composition, from gravel to sand, due to the nourishments has caused a relevant imbalance in two of the studied beaches. The fills implemented have not contained the projected beach width. The nourished area has almost disappeared, increasing the previous erosion rates. Thus, nourishment design must be improved to avoid affecting the marine flora and fauna. The cut-off of the longshore transport due to the construction of groynes for the channelization of Segura river has also caused that the erosion increases in Guardamar del Segura.

In order to make the appropriate decisions for the conservation and/or actuation within the coastal system, it is necessary a complete an historical knowledge of all those factors. This knowledge, as well as an adequate communication between the decision-makers and the coastal engineers, are key elements to achieve positive results in the medium and long term.

Acknowledgements

This research has been funded by the Generalitat Valenciana through the project GV/2019/017 (*Estudio sobre el desgaste y composición de los sedimento y su influencia en la erosión de las playas de la Comunidad Valenciana*).

References

- [1] Aragonés L., García-Barba J., García-Bleda E., López I., Serra J.C. (2015) - *Beach nourishment impact on Posidonia oceanica: Case study of Poniente Beach (Benidorm, Spain)*, Ocean Engineering. 107, 1-12.
- [2] Aragonés L., Pagán J.I., López M.P., García-Barba J. (2016) - *The impacts of Segura River (Spain) channelization on the coastal seabed*, Science of The Total Environment. 543, 493-504.
- [3] Bruun P. (1988) - *Profile nourishment: its background and economic advantages*, Journal of Coastal Research 4(2), 219-228.
- [4] Chiva L., Pagán J.I., López I., Tenza-Abril A.J., Aragonés L., Sánchez I. (2018) - *The effects of sediment used in beach nourishment: Study case El Portet de Moraira beach*, Science of The Total Environment. 628-629, 64-73.
- [5] Davison A.T., Nicholls R.J., Leatherman S.P. (1992) - *Beach nourishment as a coastal management tool: An annotated bibliography on developments associated*

- with the artificial nourishment of beaches*, Journal Coastal Research. 8, 984-1022.
- [6] Dean R.G. (1998) - *Beach nourishment: a limited review and some recent results*, Proceedings of the 26th International Conference on Coastal Engineering, Copenhagen, Denmark, 1998, Vollume, pp. 45-69.
- [7] Dean R.G., *Beach nourishment: Theory and practice*, in *Advanced Series on Ocean Engineering*. 2003. p. 21-70.
- [8] Dean R.G., Dalrymple R.A. (2002) - *Coastal processes with engineering applications*, Cambridge University Press. 475.
- [9] Dolan R., Fenster M.S., Holme S.J. (1991) - *Temporal analysis of shoreline recession and accretion*, Journal of coastal research. 723-744.
- [10] Houston J.R. (1995) - *Beach replenishment*, Shore and Beach. 63, 21-24.
- [11] [Jiménez J.A., Gracia V., Valdemoro H.I., Mendoza E.T., Sánchez-Arcilla A. (2011) - *Managing erosion-induced problems in NW Mediterranean urban beaches*, Ocean & Coastal Management. 54 (12), 907-918.
- [12] Kana T.W., *United States: South Carolina—soft engineering beach restoration*, P. Lewis, Editor. 1996: Boca Raton, FL. p. 622-626.
- [13] Kriebel D.L., *Storm erosion and sea level rise considerations for beach nourishment*, L.S. Tait, Editor. 1988. p. 139-150.
- [14] López I., López M., Aragonés L., García-Barba J., López M.P., Sánchez I. (2016) - *The erosion of the beaches on the coast of Alicante: Study of the mechanisms of weathering by accelerated laboratory tests*, Science of The Total Environment. 566-567, 191-204.
- [15] López M., López I., Aragonés L., Serra J.C., Esteban V. (2016) - *The erosion on the east coast of Spain: Wear of particles, mineral composition, carbonates and Posidonia oceanica*, Science of the Total Environment. 572, 487-497.
- [16] López M., Pagán J.I., López I., Aragonés L., Tenza-Abril A.J., García-Barba J. (2017) - *Factors Influencing The Retreat Of The Coastline*, International Journal of Computational Methods and Experimental Measurements. 5, 741-749.
- [17] Pagán J.I., Aragonés L., Tenza-Abril A.J., Pallarés P. (2016) - *The influence of anthropic actions on the evolution of an urban beach: Case study of Marineta Cassiana beach, Spain*, Science of The Total Environment. 559, 242-255.
- [18] Pagán J.I., Bañón L., López I., Bañón C., Aragonés L. (2019) - *Monitoring the dune-beach system of Guardamar del Segura (Spain) using UAV, SfM and GIS techniques*, Science of The Total Environment. 687, 1034-1045.
- [19] Pagán J.I., López I., Aragonés L., García-Barba J. (2017) - *The effects of the anthropic actions on the sandy beaches of Guardamar del Segura, Spain*, Science of The Total Environment. 601-602, 1364-1377.
- [20] Pagán J.I., López I., Bañón L., Aragonés L. (2020) - *Consequences of Anthropic Actions in Cullera Bay (Spain)*, Journal of Marine Science and Engineering. 8 (4), 240.
- [21] Pagán J.I., López I., Tenza-Abril A.J., Aragonés L., Villacampa Y. (2018) - *Urban growth and beach nourishment: Experiences on the coast of Alicante, Spain*, WIT Transactions on the Built Environment. 179, 93-102.
- [22] Pagán J.I., López M., López I., Tenza-Abril A.J., Aragonés L. (2018) - *Causes of the different behaviour of the shoreline on beaches with similar characteristics. Study*

- case of the San Juan and Guardamar del Segura beaches, Spain*, Science of The Total Environment. 634, 739-748.
- [23] Pagán J.I., López M., López I., Tenza-Abril A.J., Aragonés L. (2018) - *Study of the evolution of gravel beaches nourished with sand*, Science of The Total Environment. 626, 87-95.
- [24] Roberts J., Jepsen R., Gotthard D., Lick W. (1998) - *Effects of particle size and bulk density on erosion of quartz particles*, Journal of Hydraulic Engineering. 124 (12), 1261-1267.

DRONE REMOTE SENSING FOR COASTAL HABITATS PROTECTION

Giuseppe Piccioli-Resta¹, Sergio Fai¹, Andrea Picciolo²

¹Laboratory of photography and coastal monitoring, University of Salento - 73100 Lecce (Italy),

²Porto Cesareo Marine Protected Area - 73010 Porto Cesareo, Lecce (Italy)

phone +39 329 7343 926, e-mail: picciolo.a@gmail.com

Abstract – The growing beach touristic vocation of the Lecce Province has led to increasing human pressures along its coasts over the years, often on habitats of conservation interest. Furthermore, the ever-increasing erosion phenomena of the sandy shoreline constantly requires fast and effective monitoring activities assessing the conservation status of the dunes and shoreline. Remote sensing through the use of RPAS (Remotely Piloted Aircraft Systems or Drones) is proving to be very useful for identifying phenomena that act on a small scale and supporting and implementing protective measures according to an adaptive management approach and to favour the creation of a long term investigation model, through multi-year surveys on conservation interest habitats. The photographic data and their photogrammetric elaboration allow to find a specific point, thanks to georeferencing, on which evaluate the evolution of certain phenomena following the analysis by different types of experts able to extract a large amount of data from the same photogrammetric product, this thanks to the possibility of choosing analysis scales from the meter to the centimetre. In recent years this technique has proved to be extremely effective and interesting in the environmental analysis of a multitude of matrices. The present work consists of a protocol for monitoring the dune cordons and the nearby shorelines through the use of RPAS. This kind of survey allows to create a geodatabase with spatially-explicit detailed maps able to provide a useful tool for monitoring overtime the erosive phenomena and/or the anthropic abuses on nature to the detriment of the beach system.

Introduction

Along the Mediterranean sandy shores there are many habitats of conservation interest, such as the dune cordons present in the Porto Cesareo MPA area. The increase in anthropogenic pressure added to natural erosive phenomena requires a rapid and effective monitoring capability to determine the conservation status of these habitats. In recent years, numerous regulatory interventions have been implemented to plan the appropriate actions to protect these habitats. The Puglia Region in particular in the last decade has made operational various legislative instruments that put environmental protection first among the objectives. The Puglia Regional Coastal Plan (PRC) is the instrument that governs the use of the areas of the State Property, with the aim of ensuring the correct balance between protection of the environmental and landscapes aspects of the Apulian coast, the free use and development of recreational tourist activities. The PRC is also an instrument of knowledge of the coastal territory and in particular of the geomorphological and meteorological dynamics connected to the priority problem of coastal erosion, the evolution of which requires careful and constant

monitoring and interventions of recovery and rebalancing. The Puglia Region, therefore, entrusts new and laborious monitoring tasks of the phenomena that contribute to the dynamic morpho imbalance of the coastal strip to the coastal Municipalities. Coastal erosion can be defined by way of example, without renouncing in any way an effective expressive clarity, such as the invasion of the land by the sea. Coastal erosion is assessed by referring to a sufficiently long period of time, such as to allow to eliminate, by means of mediation, extreme events such as storms and sediment dynamics of a local character. Coastal erosion involves different types of impact or risks such as the loss of areas with economic value and the destruction of precious natural habitats, even following a single stormy event. Along the sandy coasts of Salento there are several habitats of community and priority importance subject to strong stress due to human action and extreme marine weather events. The Apulia Region issued in 2016 the "Regulation containing Conservation Measures pursuant to Community Directives 2009/147 and 92/43 and Presidential Decree 357/97 for Sites of Community Importance (SIC)". Conservation Measures provide for a series of actions and behaviors in order to improve the conservation status of different habitats of conservation interest. Conservation measures also include monitoring of species and habitats in order to evaluate the effectiveness of the measures. Local Authorities (coastal Municipalities, Park Authorities, etc.) therefore find themselves having to carry out routinely monitoring on coastal habitats, often covering large areas such as the beaches. Hence the need to develop effective and economic monitoring techniques that can be rapidly performed by local authorities. Remote sensing through the use of RPAS has proved extremely useful in identifying phenomena that act on a small scale, as support for protection measures with a view to an adaptive management approach and to encourage the creation long-term investigative models with multi-annual monitoring of habitats of conservation interest.

Materials and Methods

For this work the Phantom 4Pro drone produced by DJI was chosen. The site investigated in the tests falls in the area named "Riva degli angeli"(40°17'36.08" N - 17°47'14.07" E) in the Municipality of Porto Cesareo (LE), has an extension of about 54 hectares, and is affected by the presence of various environmental and territorial constraints due to the presence of the Porto Cesareo Marine Protected Area (Ministerial Decree 12/12/1997), the Palude del Conte and Duna Costiera Regional Natural Reserve (LR 5/2006) and Natura 2000 Network Site "Torre Colimena" (IT9130001). The area under study consists of a sandy coast with coastal dunes in *Juniperus* spp. habitat code 2250*. It is a priority habitat, characterized by forest communities dominated by junipers, in particular *Juniperus oxycedrus* subsp. *macrocarpa* and, less frequently, *Juniperus phoenicea* subsp. *turbinata*. It develops in the summit areas of the dune systems, in a more internal position than that occupied by habitat 2120 - Mobile dunes of the coastal cordon with the presence of *Ammophila arenaria* (white dunes). This type of habitat offers fundamental ecosystem services in terms of dune stabilization, soil formation and biodiversity. Non-native species are frequent mainly due to inadequate reforestation interventions conducted in the last century. The total length of the coast being monitored amounts to a total of 450 meters and the coordinates of the vertices, expressed in EPSG 32633 - WGS 1984 - UTM Zone 33N format, are respectively 17°47'10.18" E, 40°17'39.54" N for the NW vertex, 17°47'26.11" E,

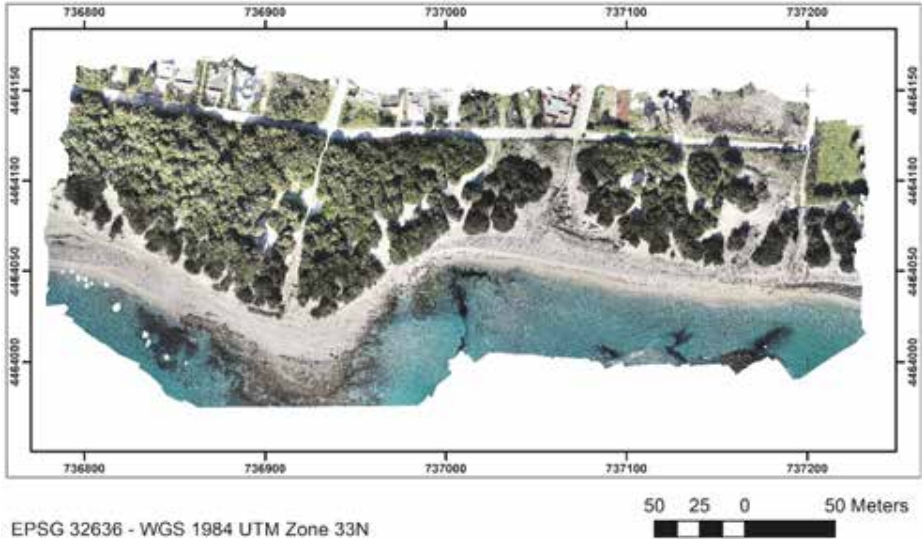

Figure 1 - January 2019 orthomosaic reconstruction.

40°17'38.20" N for the NE vertex, 17°47'25.63" E, 40°17'34.73" N for the SE vertex, 17°47'9.65" E, 40°17'36.17" N for the SW vertex. The total remote sensed area was 4.3 hectares with flights at an altitude of 50 meters (Figure 1).

During the 2019, a total of four RPAS flights sessions were performed, respectively in January, April, September and November. The survey area has been designed and the flight plans loaded for each flight session through the dedicated Pix4D Capture application. This made it possible to keep the study area vertexes unchanged during the different flight sessions, a fundamental parameter for a correct evaluation of the dynamics. The identification of ground control points (GCP) also facilitated the validation and quality control phase of the output models through the dedicated software (Pix4D Mapper).

Although the survey area has remained unchanged, the automatic acquisition parameters led to a negligible discrepancy in the resolution of orthomosaic and Digital Elevation Models (Figure 2) output from photogrammetric processing resulting from different measurements with a $\sigma = 0.003475$ for orthomosaic and $\sigma = 0.012$ for DEMs. Respectively for the month of January 349 images were acquired and the photogrammetric processing produced an orthomosaic with a resolution of 1.19 cm/pix and a DEM of 2.39 cm/pix. In April, 340 images were acquired and the photogrammetric processing produced an orthomosaic with a resolution of 1.26 cm/pix and a DEM with a resolution of 2.51 cm/pix. In September 326 images were acquired, the generated orthomosaic has a resolution of 1.26 cm/pix and the DEM of 2.53 cm/pix, finally, in November, 226 images were acquired, the resolution of the orthomosaic resulted of 1.22 cm/pix and of 2.45 cm/pix for the DEM. It was decided to set the automatic acquisition to an 80 % overlap between pictures (Table 1).

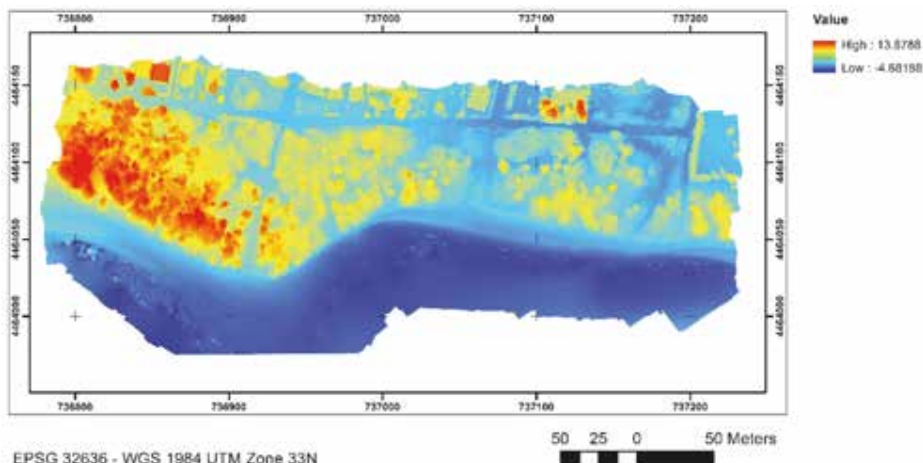

Figure 2 - Digital Elevation Model (DEM) output from drone images elaboration, January 2019.

Table 1 - Data acquisition resuming and quality detail of orthomosaic and DEM.

Month	Pictures	Orthomosaic resolution (cm/pix)	DEM resolution (cm/pix)
January 2019	349	1.19	2.39
April 2019	340	1.26	2.51
September 2019	326	1.26	2.53
November 2019	226	1.22	2.45

The orthomosaics and the georeferenced DEMs, thanks to the RPAS native GPS system, were firstly validated by importing them into Google Earth, resulting in a corrected geolocation for all of them, and then imported in GIS environment for subsequent processing phases. Once the DEMs were loaded in GIS, the height (Z) were corrected and validated using the ground quotas of the Thematic Cartography of the Puglia Region (CTR) (www.sit.puglia.it update of 2011). Using the Slope tool (3D Analyst ArcGIS) with DEM as input, it was possible to identify both the dune foot line and the shorelines in the new layers, the latter was then traced and saved as a new layer necessary for the running of the analysis (Figure 3). The same operation was carried out for each investigated month with a definitive product of 4 coastlines with the same starting and ending points. At the same time, thanks to the DEMs, it was possible to study the change in volume of the area under investigation using the month of January as a baseline to calculate the gain or net loss of sediment on an annual basis. This procedure was carried out by using the Cut Fill tool (3D Analyst ArcGIS) (Figure 5). To evaluate the dynamics linked to the shorelines, we used the Digital Shoreline Analysis System (DSAS) Version 5.0, distributed for GIS platform by the United States Geological Survey (USGS) Woods Hole Coastal and Marine Science Center. A "Baseline" feature was created on urban road infrastructure (via Lago di Cecita) for the application of the shoreline dynamic's calculation algorithm. Subsequently, the shorelines extrapolated from the DEMs

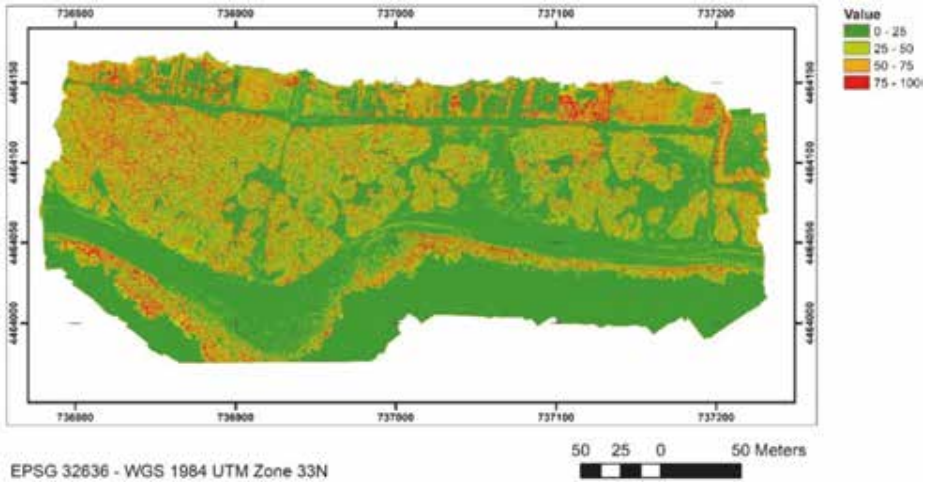

Figure 3 - Output of “Slope” tool for January 2019. Values expressed as percentage.

processed with the Slope tool were combined in a single feature. Once these two layers were created, the DSAS tool allowed, through the use of the "Attribute automator" key, the automatic population of the attribute tables with the fields necessary for the algorithm operation. The second step were the insertion, through the "Set Default Parameters" key, of the "Baseline" and "Shorelines" layers properties and the metadata population.

The "Cast Transect" key generated transects, perpendicular to the “Baseline”, which intercept the “Shorelines”. Finally, the key "Calculate Rates" and "Shoreline Forecasting" generated the output statistics, in the second case linked to long-term forecasts at 10 or 20 years. Clearly, the "Shoreline Forecasting" algorithm was not used for this analysis, focused exclusively on the assessment of seasonal variation over a single year. Each method used in calculating the variation of the coast line is based on different measurements between the positions of the coastlines over time (Table 2) [6].

Table 2 - List of DSAS outputs.

Distance Measurement	Shoreline Change Envelope	SCE
Distance Measurement	Net Shoreline Movement	NSM
Point Change	End Point Rate	EPR
Regression Statistics	Linear Regression Rate	LRR
Regression Statistics	Weighted Linear Regression	WLR

Shoreline Change Envelope

The shoreline change envelope reports a distance (in meters), not a rate. The SCE value represents the greatest distance among all the shorelines that intersect a given transect. As total distance between two shorelines has no sign, the value for SCE is always positive.

Net Shoreline Movement

The net shoreline movement is the distance between the oldest and the youngest shorelines for each transect; therefore, units are in meters. If this distance is divided by the time elapsed between the two shoreline position measurements, the result is the end point rate.

End Point Rate

The end point rate is calculated by dividing the distance of shoreline movement by the time elapsed between the oldest and the most recent shoreline. The major advantages of the EPR are the ease of computation and minimal requirement of only two shoreline dates. The disadvantage is that in cases where more data are available, the additional information is ignored. Changes in sign (in other words, accretion to erosion), magnitude, or cyclical trends may be missed [5, 15].

Linear Regression Rate

A linear regression rate-of-change statistic can be determined by fitting a least-squares regression line to all shoreline points for a transect. The regression line is placed so that the sum of the squared residuals (determined by squaring the offset distance of each data point from the regression line and adding the squared residuals together) is minimized. The linear regression rate is the slope of the line. The method of linear regression includes these features: 1- All the data are used, regardless of changes in trend or accuracy; 2- The method is purely computational; 3- The calculation is based on accepted statistical concepts; 4- The method is easy to employ [5, 15]. However, the linear regression method is susceptible to outlier effects and tends to underestimate the rate of change relative to other statistics, such as EPR [7, 15].

Weighted Linear Regression

In a weighted linear regression, the more reliable data are given greater emphasis or weight towards determining a best-fit line. In the computation of rate-of-change statistics for shorelines, greater emphasis is placed on data points for which the position uncertainty is smaller. The weight (w) is defined as a function of the variance in the uncertainty of the measurement (e) and e is shoreline uncertainty value [7]:

$$w = 1/e^2$$

1

Results

For the sake of brevity, only the Net Shoreline Movement are reported here (Figure 4). From the report (Table 3) could be assumed that the transect with ID 13 is the most dynamic, but in reality, by intercepting a stretch of low rocky coast, the variation could be the result of the wave motion dynamics on this substrate. Consequently, the areas intercepted by the transects 1 to 5, corresponding instead to sandy bottoms, are those most subjected to seasonal dynamic phenomena. The observations made so far have shown a strong dynamism

in the study area, so we wondered where this sediment goes to settle in the regression periods of the coast line. Aware of the limits of the means available, RPAS surveys data were used to give a qualitative value on the emerged dynamics. Using the Cut Fill tool (3D Analyst ArcGIS), the DEMs were used to evaluate the sediment net gain and net loss by area, between a baseline identified in January 2019 and the subsequent surveys (Figure 5). This method is particularly affected by the quality of the input data and influenced by the time of day, the presence of long shadows and the cloud cover, but still provides an idea of the areas subjected to accumulation and erosion.

Table 3 - Report summary for seasonal variability and annual changes relative to 2019 (rates are in meters/year, distances are in meters).

DISTANCE: NSM (Net Shoreline Movement, m)	
NSM OVERALL AVERAGES	
total number of transects	39
average distance	-5.16
number of transects with negative distance	22
percent of all transects that have a negative distance	56.41 %
maximum negative distance	-26.27
maximum negative distance transect ID	13
average of all negative distances	-13.71
number of transects with positive distance	17
percent of all transects that have a positive distance	43.59 %
maximum positive distance	11.92
maximum positive distance transect ID	22
average of all positive distances	5.9

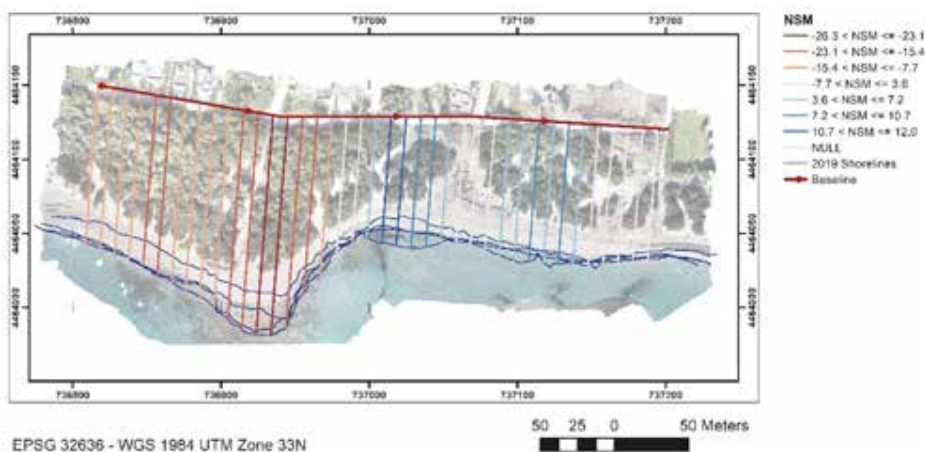

Figure 4 - Seasonal variability and annual changes relative to 2019 (NSM).

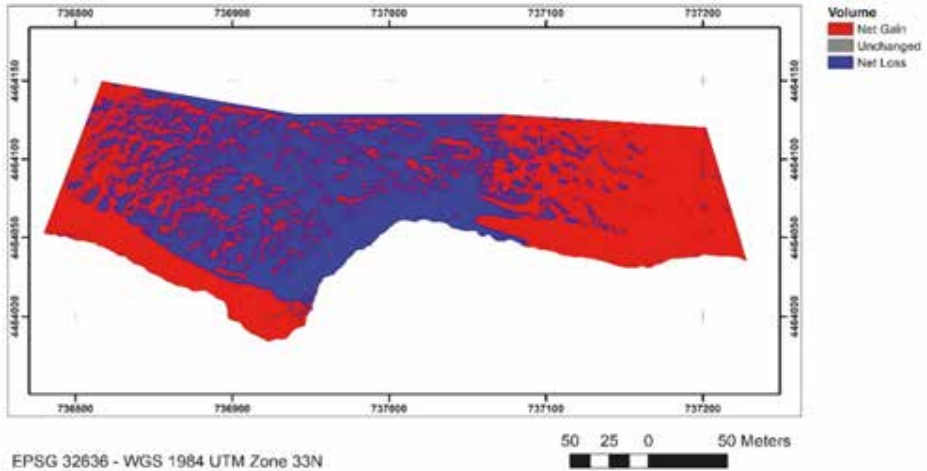

Figure 5 - Volume gain and loss for January-September confrontation.

Table 4 - Report summary relative to 1954-2019 (rates are in meters/year, distances are in meters).

DISTANCE: NSM (Net Shoreline Movement, m)	
NSM OVERALL AVERAGES	
total number of transects	39
average distance	-10.35
number of transects with negative distance	39
percent of all transects that have a negative distance	100 %
maximum negative distance	-29.95
maximum negative distance transect ID	10
average of all negative distances	-10.35
number of transects with positive distance	0
percent of all transects that have a positive distance	0 %
maximum positive distance	
maximum positive distance transect ID	
average of all positive distances	

The seasonal results were intended as a pilot analysis for the construction of a multi-year model of coastline dynamics with a view to long-term monitoring to evaluate the erosive effects in the Porto Cesareo MPA, especially in light of the evidence relating to the changes and the conservation and protection mission of the organization. To this end, it was decided to use the historical coastlines present in the project "Geotification and mosaicing of historical aerial photos of the coastal area of the AMP of Porto Cesareo and creation of maps of use in the GIS environment", relating to the years 1954, 1977, 1992, 2000, 2005, 2006 integrating to these January 2019 (Table 4, Figure 5). The same algorithm used for seasonal

dynamics was launched but in addition, thanks to the large time scale, a forecast was also implemented with a projection for the year 2030 (Figure 7).

Results reported in Table 4 clearly states that we are facing a perspective of almost total coastline regression over the whole study area, the percentage according to the Net Shoreline Movement method is equal to 100 %, with a maximum negative distance near to -30 meters, associated with the ID 10 transect. Furthermore, the mean negative distance was found to be -10.35 meters.

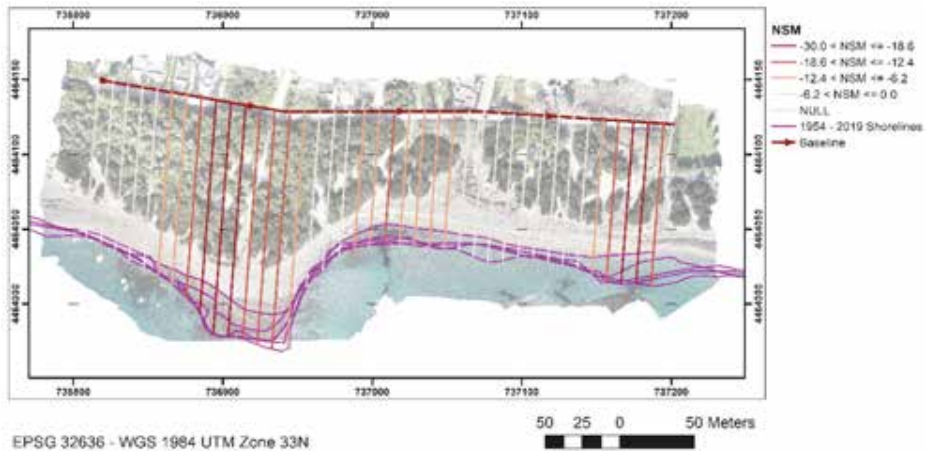

Figure 6 - Multiannual variability and shoreline changes relative to 1954-2019 elaboration (Net Shoreline Movement).



Figura 7 - 2030 shoreline forecast.

Conclusions

The objective of this work was to highlight the effectiveness of widely used, cost-effective and reliable tools, together with the necessary expert staff involved in monitoring activities of protected areas, not only in order to have a mere acquisition of data, but also to facilitate their rapid processing and integration in an adaptive management of protected areas. In the specific case of a marine protected area, where land-sea interactions are the very essence of threats to the environment, together with the stressors of global climate change, an increase in direct knowledge of the environment and the threats it faces is mandatory.

The methodology presented here, thanks to a simple approach based on tools validated and used globally, is in our opinion a small step in this direction, to face those challenges, once future but now current and no longer postponable.

References

- [1] AA.VV, 2010a- Regione Puglia – Settore Demanio Marittimo – *Circolare “Interventi urgenti per fronteggiare l'erosione costiera provocata dalle mareggiate dei primi mesi del 2010*
- [2] AA.VV. (2008) – *Consorzio di Gestione dell'Area Marina Protetta "Porto Cesareo" Analisi delle trattorie evolutive storiche della fascia costiera dell'AMP Porto Cesareo*. Relazione Tecnica
- [3] Arzeni S. (2005) – *Cartografia dello stato di conservazione e della vulnerabilità ambientale dei cordoni dunali del Comune di Porto Cesareo* (“Carta delle Dune”). P.O.R. PUGLIA 2000. 2006. Relazione Tecnica Finale
- [4] Bianco R., Caldara M., Capolongo D., Damiani L., Pennetta L., Petrillo A. F., Uricchio V., Vurro M., (2004) – *Il monitoraggio delle coste pugliesi con l'ausilio di tecniche innovative*. Convegno Nazionale della Società di metodologie per il rilevamento a grande scala e per il monitoraggio. Chia Laguna, Cagliari 22-24 settembre 2004
- [5] Crowell, M.; Douglas, B.C., Leatherman, S.P., (1997) – *On Forecasting Future U.S. Shoreline Positions: A Test of Algorithms*, Journal of Coastal Research, 13 (4), pp. 1245-1255
- [6] Himmelstoss E. A., Henderson R. E., Kratzmann M. G., Farris A. S. (2018) *The Digital Shoreline Analysis System (DSAS) Version 5.0 User Guide*. USGS Science for a changing world
- [7] Genz, A.S.; Fletcher, C.H.; Dunn, R.A.; Frazer, L.N., Rooney, J.J. (2007) – *The Predictive Accuracy of Shoreline Change Rate Methods and Alongshore Beach Variation on Maui, Hawaii*. Journal of Coastal Research 23, 1: 87–105.
- [8] Girasoli D., (2010) – *Caratteristiche sedimentologiche e morfologiche del tratto litorale compreso tra Porto Cesareo e Torre Colimena (Salento occidentale, Puglia)*. Università la Sapienza Tesi di Laurea
- [9] Mastronuzzi G., Sansò P. (2000) – *Boulder transport by catastrophic waves along the Ionian coast of Apulia (southern Italy)*. Marine Geology, 170, 93-103.
- [10] Mastronuzzi G., Sansò P. (2010) – *Indagine geoambientale delle spiagge di Porto Cesareo – Punta Prosciutto*. Relazione Tecnica

- [11] Regione Puglia (2007) – *L’erosione costiera in Europa, in Italia e in Puglia* “Attività finalizzate alla redazione del Piano Regionale delle Coste (P.R.C.) della regione Puglia”. Dipartimento di Architettura e Urbanistica e del Dipartimento di Ingegneria delle Acque e di Chimica (Laboratorio di Ricerca e Sperimentazione per la Difesa delle Coste (LIC))
- [12] Regione Puglia, (2011) – *Piano Regionale delle Coste*. Deliberazione di Giunta Regionale n. 2273 del 13-10-2011.
- [13] Regione Puglia. POR 2000 - 2006. – *Monitoraggio degli interventi di difesa costiera e dell’evoluzione dei litorali (- Misura 1.3, area di azione 2, sottoazione 2B, - Misura 1.3, ara di azione 4, sottoazione 4C)* Dipartimento di Geologia e Geofisica (DGG) dell’Università di Bari, del Dipartimento di Ingegneria delle Acque (DIA) del Politecnico di Bari e dell’Istituto di Ricerca sulle Acque (IRSA) del C.N.R.
- [14] Regolamento Regionale 10 maggio 2016, n. 6 Regolamento recante Misure di Conservazione ai sensi delle Direttive Comunitarie 2009/147 e 92/43 e del DPR 357/97 per i Siti di importanza comunitaria (SIC) - Bollettino Ufficiale della Regione Puglia - n. 54 del 12-5-2016
- [15] Dolan R., Fenster M. S., HolmeSource S. J. (1991) – *Temporal Analysis of Shoreline*. Journal of Coastal Research, Vol. 7, No. 3, pp. 723-744
- [16] Vitale, (2015) – *Rilievo GPS del piede del cordone dunale e della spiaggia emersa*. Relazione Tecnica
- [17] Himmelstoss, E.A., Henderson, R.E., Kratzmann, M.G., and Farris, A.S., (2018) – *Digital Shoreline Analysis System (DSAS) version 5.0 user guide*: U.S. Geological Survey Open-File Report 2018–1179, 110 p., <https://doi.org/10.3133/ofr20181179>

IMPACT OF CLIFF EROSION ON MARINE SEDIMENT COMPOSITION - INDICATION OF LOCAL COASTLINE EVOLUTION (VRGADA ISLAND, CROATIA)

Kristina Pikelj, Nina Furčić

University of Zagreb, Faculty of Science, Department of Geology, Horvatovac 102a,
10000 Zagreb (Croatia), phone: +38514606113, email: kpikelj@geol.pmf.hr

Abstract – Surface sediment along the carbonate-bordered eastern Adriatic is highly carbonaceous material, composed largely of biogenic skeletal material. Local outcrops of soft-rock material such as Eocene flysch and Pleistocene sandstones may locally change the composition of the surface sediment cover. Highly erosive coastal cliff developed in Pleistocene sediments on the Vrgada Island gave rise to the idea that local seabed surface sediment may reflect the composition of the cliff sediment.

Preliminary results of sedimentological analyses showed that sediment samples collected on both sides of the cliff contain material eroded mostly from the eastern side of the cliff. Subsequent longshore drift caused by dominant waves likely sort fallen material, transporting its finer fractions to the northern side and further into the sea.

Introduction

Eastern Adriatic coast is a primary karstic transgressive coast, mostly built of Mesozoic carbonates (over the 90 % of the coast length). Eocene flysch is represented by approx. 6 % in length, while other usual younger soft rocks are Quaternary clastics [1]. Surface seabed sediment along the eastern Adriatic coast is mainly composed of mixed carbonate-siliciclastic sandy sediment, where carbonates are generally of biogenic origin. Biogenic particles originate from a typical temperate assemblage of carbonate secreting marine invertebrate, with molluscs, foraminifera, bryozoans and red calcareous algae being the most common [3, 4]. The deposition of recent biogenic carbonates is enabled due to the scarce terrigenous supply resulting from the karstic relief on which poor network of karstic rivers has been developed. Their sediment input is low, and sediment material supplied to the sea usually remains at river mouths. The exception is the Neretva River, an allogenic karstic river which discharges a large quantity of particulate sediment into the Adriatic compared to other Croatian coastal rivers.

In general, the mineral composition of the non-carbonate component in the surface sediment points to the Eocene flysch as one of the main sources of the siliciclastic material. Flysch outcrops are being eroded in the coastal zone by the denudation processes and wave abrasion, while surface flysch lithology underlying karstic river beds contribute to its particle load. According to [3], much of the siliciclastic component has been found in very fine sand and mud fractions. Locally, other types of lithologies such as Pliocene and Pleistocene sands and sandstones may affect the composition of surface seabed sediment. One such example is deposit sequence on the Vrgada Island situated in the middle of the Croatian coast (Fig. 1).

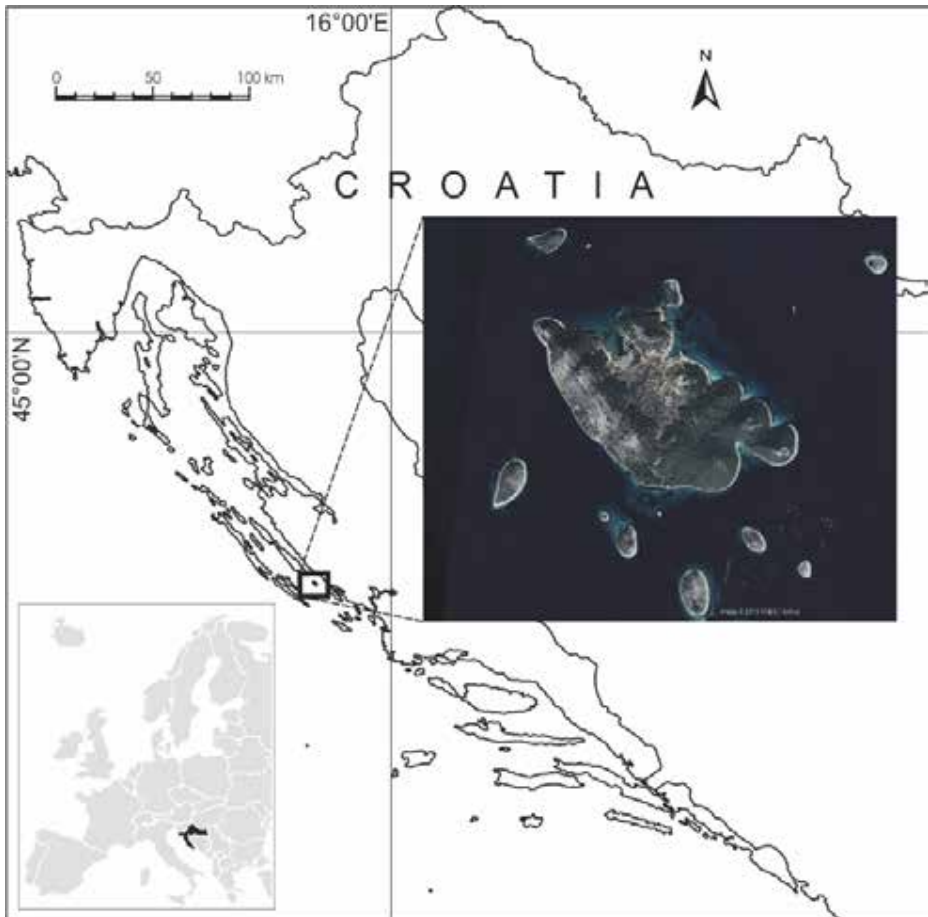

Figure 1 - Location map of the Vrgada Island along the Eastern Adriatic coast.

Vrgada Island is composed mostly of Cretaceous limestones, however, in its NW part Pleistocene sediments crop out in several places [4, 5, 6]. The most attractive appearance of this soft-rock depositional succession is the coastal cliff (Fig. 2). Together with beaches and other typical coastal processes, cliffs are rare forms along the Eastern Adriatic, due to the prevailing carbonate lithology along the coast. Thus, it is expected that local erosion of soft-rock cliffs may influence the composition of the surface marine sediment.

The aim of this work is to examine this claim through classical sedimentological analyses of marine sediment. Furthermore, it is expected that results of sediment characteristics may point to the direction of sediment transport along the coast, in front of each cliff side.

Study site

The ~15 m thick soft-rock depositional Pleistocene succession on the Vrgada Island is a triangle-shaped coastal cliff subjected to the coastal erosion (Fig. 2). The evidence of ongoing coastal erosion is especially visible on its eastern side in form of weathered material on the cliff toe, numerous vertical cracks (observed during the fieldwork), and trees with bare and exposed roots. Its eastern sub-vertical side is exposed to waves of two most dominating winds: *Bura (Bora)* and *Jugo (Sirocco)* and, as shown on Fig. 2.

The northern part is less steep and overgrown with pine trees, so the true cliff form is partially hidden (Fig. 2). This section of the coast experiences mild north-western wind (*Maestral*) operating mostly during the summer. Both sides of the cliff are fronted by the narrow sandy beach, a rare type of the beach along the Croatian coast.



Figure 2 - Eroding coastal cliff on the Vrgada Island; view from east (left photo) and from north (right photo).

Materials and methods

In total, ten surface marine sediment was collected along two profiles, almost perpendicular to both sides of cliff faces: six on the eastern and four on the northern side, following the depth gradient up to 25 m (Fig. 3).

Sediment samples were dried, weighed, and wet sieved using the 7 standard sieves of 1 mesh phi. Sedigraph was used to analyze fractions < 0.063 mm. Sediment classification was done after [7]. Carbonate content was calculated according to the volumetric measurement of CO₂ evolved after each sample being treated by 1:1 diluted HCl acid, using the Scheibler apparatus.

Coarse-grained fractions (gravel to very fine sand) of each sediment were examined using a stereomicroscope for quantitative identification of marine skeletal grains and grains supplied after cliff erosion.

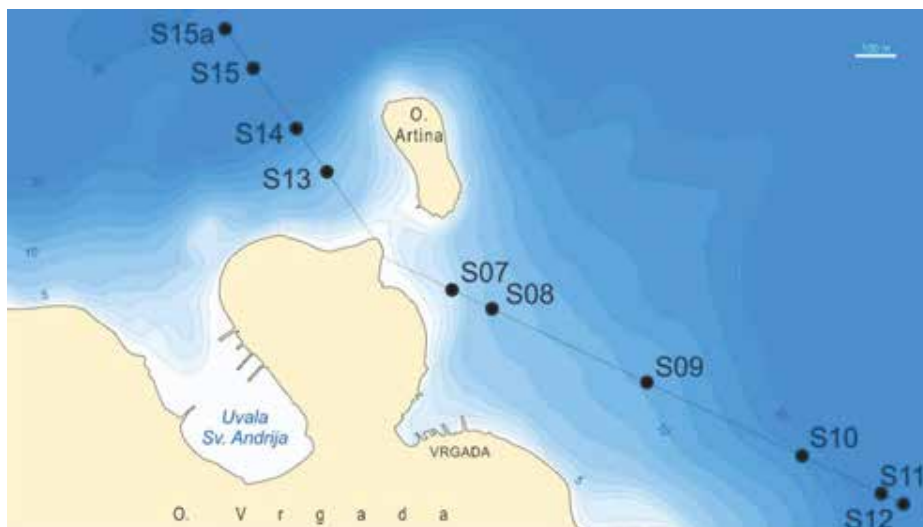

Figure 3 - Locations of sediment sampling along both profiles. Uvala = bay.

Results

All relevant results are shown in Table 1. Six samples on the eastern side were characterized as sands: the first two collected closest to the cliff (S07 and S08) are gravelly sands with the mean size of 608 and 705 μm , respectively, while the rest are gravelly muddy sands, with Mz varying between 157 and 240 μm . Their carbonate content ranged between 78 % and 88 % with no obvious trend observed. Microscopic examination showed that the shallowest three samples (S07-S09) contained a higher amount of coarse grains resulting from cliff erosion, while the other three (S10-S12) contained mostly marine carbonaceous sediment.

Table 1 - Surface sediment characteristics.

Sample:	Sediment type (after Folk, 1954):	Carbonate content (%):
S07	gravelly sand	78
S08	gravelly sand	84
S09	gravelly muddy sand	80
S10	gravelly muddy sand	82
S11	gravelly muddy sand	80
S12	gravelly muddy sand	79
S13	gravelly muddy sand	35
S14	gravelly muddy sand	51
S15	gravelly mud	47
S15a	gravelly mud	38

Samples collected on the northern side of the cliff are more fine-grained than the previous ones; they are characterized as gravelly-muddy sands (S13 and S14) with Mz of 60 μm and 97 μm respectively, and gravelly muds (S15 and S15a) with Mz of 43 and 28 μm respectively. Their carbonate share was consistently lower (35–52 %) compared to samples along the eastern profile. Microscopic examination showed the dominance of particles derived from the cliff, and in many cases, quartz recognized as dominant.

Discussion

Cliff on the Vrgada Island is a rare example of cliffs in soft rocks along the Eastern Adriatic Coast. According to [4], much of the siliciclastic material forming the cliff was supplied from the Eocene flysch basins in the hinterland. There is also an indication that some of the material probably deposited from volcanic eruptions during Pleistocene. Soft-rock cliffs are more prone to weathering and slope processes in general, compared to tectonic cliffs in carbonates, characteristic of southern coasts of many Croatian islands [1].

Both sides of the cliff are fronted by a sandy beach. This sandy character is less obvious along the eastern part due to the material constantly falling from the cliff; thus, the beach along the eastern side contains more gravel. The shallowest two samples S07 and S08 on the eastern part are at the same time and coarsest samples in the set. Much of these fractions contained coarse-grained material fallen from the cliff, as shown by microscopic examination. However, their carbonate content is rather high (Table 1), higher compared to the average of 61 % for the surface sediment of the Eastern Adriatic given by [1]. The amount of carbonate in these coarse fractions are the results of more resistant tube-like carbonate concretions [4]. Moreover, the shallowest samples are constantly reworked by waves, therefore, their coarseness is probably a result of the wave action. Sample S09 showed approx. the same quantity of cliff and marine material, while in samples S10-S12 marine component dominates.

Beach on the northern side shows its truly sandy character, without gravitationally lowered material, as can be seen in the Fig. 2. Marine sediment samples follow the same pattern: they contain less gravel and more fine sand and mud, mostly silt (not shown in Table 1!). Carbonate component in these samples are much lower (sometimes up to 50 % lower; Table 1) compared to samples from the eastern side, and is lower than 61 %, the average for the Eastern Adriatic [2]. As shown by [2] and [3], much of the fine sand and silt fractions along the Eastern Adriatic generally contain a higher amount of quartz grains. Therefore, it is likely that sediment samples along the northern profile off the northern side of the Vrgada cliff collect more quartz grains, as confirmed by the microscopic examination. In general, preliminary results of classical sedimentological analyses presented here showed that there are differences in sediment composition between two seabed sections in front of the two cliff sides on the Vrgada Island.

Considering a higher carbonate content and overall coarseness of the sediment, one could conclude that the sediment in front of the eastern part of the Vrgada cliff is a typical highly carbonaceous and coarse eastern Adriatic seabed cover, described by [2]. However, the fact is that the higher coarseness degree and higher carbonate amount, in this case, result from the material fallen from the cliff, where material kept in surface sediment is largely composed of cliff carbonate concretions. On the other hand, material deposited in front of

the northern cliff segment (more protected from strong winds and waves, and covered by vegetation) was much more affected by the material eroded from the cliff, containing less carbonates and more quartz grains derived from the cliff. The mechanism of such differences in sediment composition and sediment distribution has been ascribed to the joint action of intensive cliff erosion on the eastern side and north-westward longshore drift caused by dominant waves. Waves approaching from the east are induced by *Bura* and *Jugo*, both typical for the winter season. Besides wave action during which wave notches may develop (as observed during winter fieldwork), the occurrence of *Bura* gusts approaching the cliff face almost in shore-normal direction may mimic hammer beat along with a beat sound effect. This action weakens segment by segment of the cliff face, accelerating its erosion. The synergy of such events with before mentioned wave action, usual slope processes, and natural affinity of soft rocks to be mechanically eroded may lead to the massive cliff erosion observed in the case of Vrgada Island.

Once eroded, material from the cliff is being sorted along the eastern side, leaving generally coarse-grained fraction on the beach and on the shoreface. Fine-grained fraction on the other hand is being transported further and eventually distributed along the northern side of the cliff. Indeed, as shown in the Fig. 2, beach on the northern side of the cliff is mostly covered by sand. Since being fine-grained, this sand may easily be withdrawn into the sea and finally be deposited on the seabed. However, in order to corroborate this hypothesis, additional measurements focused on the beach morphology and beach dynamics are currently being conducted.

Acknowledgements

We thank Stipe Muslim for all the help during the fieldwork and Robert Koščal for technical support during drawing preparation.

References

- [1] Pikelj, K., Juračić, M. (2013) - *Eastern Adriatic Coast (EAC): geomorphology and coastal vulnerability of a Karstic Coast*. J. Coastal Res. 29 (4), 944–957.
- [2] Pikelj, K. (2010) - *Composition and origin of seabed sediments of the eastern part of the Adriatic Sea* (in Croatian). Unpublished Ph.D. Thesis, University of Zagreb, p. 239.
- [3] Pikelj, K., Jakšić, L., Aščić, Š., Juračić, M. (2016) - *Characterization of the fine-grained fraction in the surface sediment of the eastern Adriatic channel areas*. Acta Adriat. 57, 195–208.
- [4] Banak, A., Pikelj, K., Lužar-Oberiter B., Kordić, B. (2020) - *Sedimentary record of Pleistocene aeolian - alluvial deposits on Vrgada island (eastern Adriatic coast, Croatia)*. Submitted
- [5] Mamužić, P., Nedela-Devide, D. (1963) - *Basic Geological Map of SFRY: Sheet Biograd, scale 1:100 000 (K33-7)*. Institut za geološka istraživanja; Savezni geološki zavod, Beograd, 1 sheet.

- [6] Mamužić, P. (1962-1965) - *Basic Geological Map of SFRY: Sheet Šibenik, scale 1:100 000 (K33-8)*. Institut za geološka istraživanja; Savezni geološki zavod, Beograd, 1 sheet.
- [7] Folk, R. L. (1954) - *The distinction between grain size and mineral composition in sedimentary rock nomenclature*. J. Geol. 62, 344-356.

SESSION

**FLORA AND FAUNA OF THE LITTORAL SYSTEM:
DYNAMICS AND PROTECTION**

Chairman: Davide Travaglini
Department of Agriculture, Food,
Environment and Forestry
University of Florence

FLORA AND FAUNA OF THE LITTORAL SYSTEM: DYNAMICS AND PROTECTION

Coasts are ecotones between sea and land. These environments, characterized by being the transition point between water (with high salinity contents) and land are highly dynamic and subjected to disturbance factors due to both cyclic phenomena (tides) and unpredictable phenomena (sea and coastal storms), and to human pressure. All these features make up an extremely vulnerable system, so that its flora and fauna show particular morpho-physiological, ecological and behavioral adaptations.

A total of 17 papers coming from six different countries have been published in the Proceeding of the Session *Flora and Fauna of the littoral system: dynamics and protection* of the Eighth Symposium *Monitoring of Mediterranean coastal areas: problems and measurement techniques*.

The thematic areas covered by these papers refer basically to two main issues: the assessment of the quality status of waters in coastal ecosystems, including the use of new technologies for such purposes, and actions carried out to improve management, conservation, monitoring, and control of coastal habitats. Here follows a short introduction to the contents of the papers.

Macroalgal communities are proposed by the Water Framework Directive (WFD, 2000/60/EC) as one of the biological quality elements to be used for the assessment of the ecological quality status of coastal waters bodies. *Posidonia oceanica* (L.) Delile (Magnoliophyta) is sensitive to anthropogenic effects and it is considered an effective biological indicator for predicting the status of coastal marine ecosystems.

Bellissimo et al. used the *Posidonia oceanica* Rapid Easy Index (PREI) method to assess for the first time the ecological status of the Sicilian water bodies (Italy).

Stocco et al. used well known acquisition systems integrated with advanced methodologies for multiscale mapping of *Posidonia oceanica* and *Cymodocea nodosa* grasslands in pilot sites of the Calabria Region (Italy).

In the context of the Integrated Marine Pollution Monitoring Programme of Turkey, Akçalı et al. reports the baseline results and the status of *Posidonia oceanica* for two stations, which were monitored between 2018 and 2019.

The work of Bedini et al. reports an interesting transplanting method of *Posidonia oceanica*, which is proposed to overcome the problems of replanting *Posidonia oceanica* plant by plant. The transplanting method was applied in the Gulf of Follonica (Italy). The results show that a high percentage of transplanted plants survived, and that many new plants sprung up from most of the clods, indicating that *Posidonia oceanica* clods adapted well to the new settlement ground.

The macroalgae based index CARTography of LITtoral and upper-sublittoral rocky-shore communities (CARLIT), which is based on widely distributed communities whose response to anthropogenic pressure is well-known, allows to provide a rapid assessment of water quality. Such index was used to assess the ecological status along the Sicilian (Bellissimo et al.) and the Calabrian (Stocco et al.) coasts (Italy).

The Marine Floristic Ecological Index (MARFEI) was tested to assess the ecological status of the coastal and transitional waters in the Marmara Sea (Turkey) using

marine benthic macrophytes (macroalgae and angiosperms) (Taşkın et al.)

The work of Humeniuk et al. reports the results of a study carried out in Ukraine to analyze the qualitative and quantitative composition of toxicants (Cd, Pb) in the waters of the rivers Pripyat and Turiya.

Idmoussi et al. reports the results of a study aimed to assess the composition, abundance, and diversity of phytoplankton assemblage along the Moroccan Mediterranean coast.

New technologies provide useful data to study and monitor marine waters and coastal environments. For instance, remote sensing techniques have been widely used to measure the qualitative parameters of waterbodies (i.e., suspended sediments, chlorophyll-a, and pollutants). A large number of different sensors on board various platforms, such as satellite, airplanes and drones are currently used to measure the amount of radiation at different wavelengths reflected from the water's surface. In the Session Flora and Fauna three papers used new technologies for marine waters applications and for conservation of coastal landscapes.

Bellia et al. used a drone to obtain high-altitude photos in four bays in Malta to map shallow-water benthic assemblages using automatic and manual techniques. The results of this study show that the automated drone method was more efficient and more accurate than the manual approach.

Ippoliti et al. estimated the chlorophyll-a and dispersion of sediments in the sea using Sentinel-2 images. The estimates were compared with in situ data collected in monitoring stations in Abruzzo (Italy), providing encouraging results.

Romano et al. used precision agriculture techniques in the coastal area of Metapontino (Italy) in order to evaluate the performance of such techniques to obtain economic benefits and to reduce the pressure on the environment.

Regarding the papers describing actions carried out to improve management, conservation, monitoring, and control of coastal habitats the study of Beccarisi describes the monitoring activity carried out on habitats and plant species in a protected area in Puglia (Italy). The study identifies the pressure and threat factors that negatively affect the conservation of habitats and provides management indications.

The work of de Francesco et al. presents a study aimed at describing and mapping the marine-coastal habitats of conservation concern (according with Habitat Directive) in the Abruzzo coast (Italy). The results of the study provide supporting information for the proposal of new Natura 2000 sites.

The work of Rugge et al. describes the objectives and the activities of a project aimed to improve the ecological continuity between natural wetlands of the Adriatic coast in Puglia (Italy).

The work of Sgambati et al. describes a management model for marine protected area consisting of three interconnected actions: monitoring, conservation, and information. The management model aims to reduce illegal activities and to promote environmental awareness.

Littoral ecosystems are under a variety of threats including overexploitation of fishery resources. In this context, Simeone et al. reports the results of 5 years of monitoring and control of illegal fishing inside the Gaiola Underwater Park, a marine protected area located in Naples (Italy). The study of Morel et al. describes the characteristics of the Small-Scale Fisheries in the Gulf of Lion Marine Natural Park (France) based on data collected through questionnaires compiled by local fishers.

Concluding this short introduction, I'd like to thank all the Authors for their valuable work, and I wish all of you a pleasure read of the papers published in the Session "Flora and Fauna of the littoral system: dynamics and protection".

Davide Travaglini
Department of Agriculture, Food,
Environment and Forestry
University of Florence
Email davide.travaglini@unifi.it

***POSIDONIA OCEANICA* MONITORING SYSTEM ON THE COAST OF AEGEAN SEA OF TURKEY**

Barış Akçalı¹, Ergün Taşkın², Gökhan Kaman³, Alper Evcen³, Hayati Çalık³, Onur Akyol³

¹Dokuz Eylül University, Institute of Marine Sciences and Technology, Haydar Aliyev Bulvarı, İnciraltı-İzmir, 35430, Turkey

²Manisa Celal Bayar University, Faculty of Arts & Sciences, Department of Biology, Muradiye-Manisa, 45140, Turkey, ergun.taskin@cbu.edu.tr

³TÜBİTAK, Marmara Research Center, Environment and Cleaner Production Institute, Gebze-Kocaeli 41470, Turkey

Abstract – Seagrass monitoring is a basic tool for measuring the condition of meadows in parallel to the environmental conditions. *Posidonia oceanica* meadows are very sensitive to anthropogenic effects. In the present study, two monitoring stations of *Posidonia oceanica* meadows were established on the Aegean coasts of Turkey in the years 2018 and 2019, at 26 m depth in Ildır Bay (İzmir, Turkey), and at 33 m depth in Kara Ada (İzmir, Turkey). The *P. oceanica* meadows upper and lower limits were defined by balisage systems. In the laboratory, lepidochronological, morphometric, and phenological parameters were also studied.

Introduction

Posidonia oceanica (L.) Delile (Magnoliophyta) is the most widespread species which is endemic to the Mediterranean Sea [1, 2]. *P. oceanica* grows between 0 to 40 meters deep. These meadows constitute a key ecosystem and have an important ecological role. They also stabilize the sediment, protect the beaches from erosion and has a positive effect on the clarity of water [3,4,5]. *P. oceanica* is a perennial species growing vegetatively by means of long-lasting rhizomes [6,7]. Lateral growth of established *P. oceanica* beds is very slow, i.e. 1÷6 cm yr⁻¹ [8]. According to this growth rate, the expansion from a single seed to a circular bed of 27 m radius would take about 600 years [9].

P. oceanica meadows are very sensitive to anthropogenic effects. As a result, the decline in the distribution of *P. oceanica* meadows has started, especially since the 1960s. This regression is dramatic, especially around large urbanized areas and port facilities [10, 11, 12, 13, 14, 15]. *P. oceanica* is an effective biological indicator for predicting the status of coastal marine ecosystems [16,17,18].

Seagrass monitoring is a basic tool for measuring the condition of meadows and environmental conditions. It is also very important for early detection in case of deterioration of *P. oceanica*'s condition. Monitoring is also a necessary method for all kinds of preventive or improvement works. Since the 1980s, diminishing has been observed in seagrass meadows, monitoring programs have been established for 31 seagrass species in more than 40 countries. Monitoring activities are essential tool for determining the situation of the *P. oceanica* meadows.

In the present study, two monitoring stations of *Posidonia oceanica* meadows were established on the Aegean coasts of Turkey in the years 2018 and 2019, at 26 m depth

in Ildır Bay (İzmir, Turkey), and at 33 m depth in Kara Ada (İzmir, Turkey). The *P. oceanica* meadows upper and lower limits were defined by balisage systems. In the laboratory, lepidochronological, morphometric, and phenological parameters were also studied.

Materials and Methods

Two monitoring stations of *Posidonia oceanica* meadows were established on the Aegean coasts of Turkey as a part of the national Integrated Marine Pollution Monitoring Programme (MoEU, Turkey) (Figure 1). Scuba equipment, GPS, 11 concrete markers (about 15÷20 kg per marker), 33 iron stakes (about 1 m long), 11 iron stakes for photography (about 1.5 m long), and 11 PVC numbered plates were used to established the underwater monitoring station [19]. One underwater digital camera, one compass, diving computer, one PVC underwater slate, and one quadrat (60 cm x 60 cm) were also used for scientific measurements.

Three teams with two divers in each team have set up the *P. oceanica* lower limit monitoring system. The first step was finding the appropriate lower limit for the system. After that, the concrete blocks placed through the limit and stabilized with 1 m iron sticks. Subsequently, the photo stakes were nailed in front of blocks (1,5 m), numbers and small buoys were tied to blocks. Position of the markers and the photo-stakes in the two monitoring stations (Ildır Bay and Kara Ada) of *P. oceanica* meadows on the Aegean coasts of Turkey were given in Figures 2 and 3. Panoramic views of some markers of the two monitoring stations were also given in Figures 4 and 5.

The materials were collected by a quadrat (60 cm x 60 cm) divided into 9 quadrats (20 cm x 20 cm) per station for lepidochronological and phenological measurements [19], and samples were preserved in 2÷5 % formaldehyde in sea water, and later it was measured in the laboratory.



Figure 1 - Monitoring stations (Ildır Bay and Kara Ada) in the Aegean Sea (Izmir, Turkey).



Figure 2 - Position of the markers and the photo-stakes in the Ildır Bay (İzmir, Aegean coasts of Turkey) (B: marker, P: photo-stakes).



Figure 3 - Position of the markers and the photo-stakes in Kara Ada (İzmir, Aegean coasts of Turkey) (B: marker, P: photo-stakes).

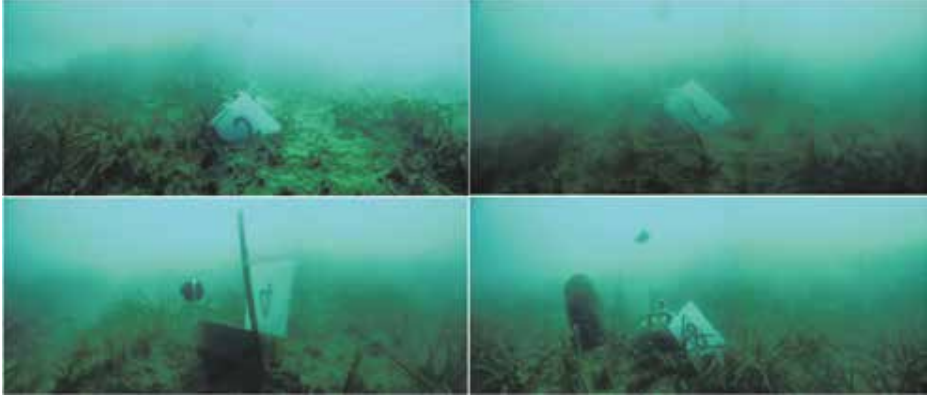

Figure 4 - Panoramic views of some markers (2,4,7,8) in the Ildır Bay monitoring station (İzmir, Aegean coasts of Turkey) in the year 2018.

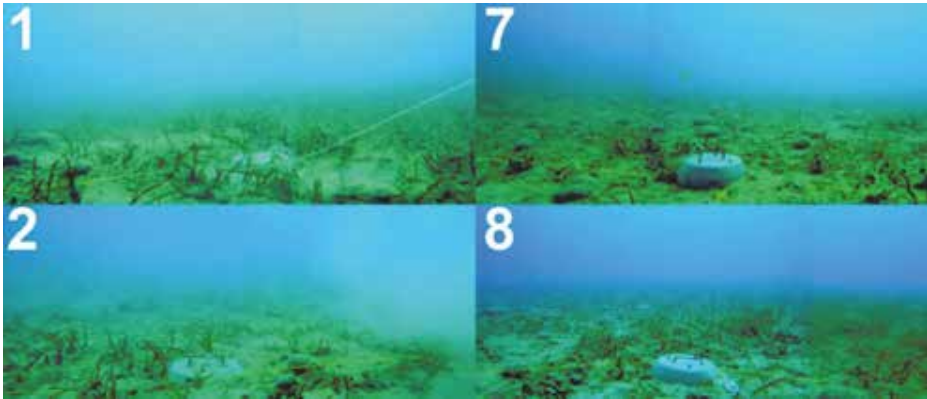

Figure 5 - Panoramic views of some markers (1, 2, 7, 8) in Kara Ada monitoring station (İzmir, Aegean coasts of Turkey) in the year 2019.

Results

In the context of the national Integrated Marine Pollution Monitoring Programme (MoEU, TR), two monitoring stations were recently established at Ildır and Kara Ada (İzmir, Aegean Sea, Turkey) during the years 2018 and 2019. These two pilot studies are among the first monitoring exercises on the meadows included in the national monitoring program of Turkey. The baseline results and the status of *P. oceanica* were given in the present study.

Ildır Bay Monitoring Station (İzmir, Aegean coasts of Turkey)

At the Ildır station, having the average depth of 25.1 ± 0.3 m and the density of the shoots 87.9 ± 23.9 shoot/m², coverage was 26.8 ± 0.1 %, horizontal rhizome percentage was

(plagiotropic rhizome) 96.1 ± 0.1 % (Table 1). According to these results, Ildir station status was regarded as poor. Lepidochronological analysis behind the lower limit in the Ildir Bay station was given in Table 2.

Table 1 - Main characteristics of the *Posidonia oceanica* monitoring station in the Ildir Bay (İzmir, Aegean coasts of Turkey) (P: Poor, M. Moderate, H: High).

Scientific measuring	2018 results	2018 Ecological Status	2019 results	2019 Ecological Status
Depth (m)	25.1 \pm 0.3	P	25.1 \pm 0.3	P
Density of shoots (m ²)	87.9 \pm 23.9	P	50.9 \pm 26.4	P
Coverage (%)	26.8 \pm 0.1	M	13.4 \pm 0.1	M
Horizontal rhizome (%)	96.1 \pm 0.1	H	29.1 \pm 0.2	M
Type of Limit	Sparse	M	Sparse	P

Table 2 - Lepidochronological analysis behind the lower limit at the *Posidonia oceanica* monitoring station in the Ildir Bay (İzmir, Aegean coasts of Turkey).

Lepidochronological year	Number	Number of scales	Growth of rhizomes (mm)
2018	10	8.8 \pm 1.9	3.4 \pm 0.7
2017	8	9.1 \pm 1.5	3.3 \pm 0.8
2016	4	9.0 \pm 0.0	3.6 \pm 0.4
2015	1	9.0	3.8

Kara Ada Monitoring Station (İzmir, Aegean coasts of Turkey)

At the Kara Ada station, the average depth was 32.9 ± 0.2 m and the density of the shoots was 75.8 ± 14.7 shoot/m² and the coverage was 25.5 ± 0.1 %, horizontal rhizome percentage was (plagiotropic rhizome) 50.0 ± 0.2 % (Table 3). According to these results, Kara Ada station status regarded between moderate and good. Lepidochronological analysis behind the lower limit in Kara Ada station was given in Table 4.

Table 3 - Main characteristics of the *Posidonia oceanica* monitoring station in Kara Ada (İzmir, Aegean coasts of Turkey) (P: Poor, M. Moderate, G: Good).

Scientific measuring	2019 results	2019 Ecological Status
Depth (m)	32.9 \pm 0.2	G
Density of shoots (m ²)	75.8 \pm 14.7	M
Coverage (%)	25.5 \pm 0.1	G
Horizontal rhizome (%)	50.0 \pm 0.2	G
Type of Limit	Sparse	P

Table 4 - Lepidochronological analysis behind the lower limit at the *Posidonia oceanica* monitoring station in Kara Ada (İzmir, Aegean coasts of Turkey).

Lepidochronological year	Number	Number of scales	Growth of rhizomes (mm)
2018	10	8.7±1.8	2.8±0.9
2017	8	8.0±1.6	3.2±0.6
2016	5	6.8±0.8	3.2±0.7
2015	1	11.0	3.7

Discussion

In the present study, two monitoring studies of *Posidonia oceanica* meadows were made from two different stations, and at different depths (Ildır Bay: 25.1 ± 0.3 m, and Kara Ada: 32.9 ± 0.2 m) on the Aegean coasts of Turkey. Ildır Bay monitoring station baseline measurements were done in 2018 and monitoring was continued in 2019, the highest value of the shoot density was found in 2018 (87.9±23.9 shoot/m²) than 2019 (50.9±26.4 shoot/m²), and the highest value of the horizontal rhizome (plagiotropic rhizome) was also found in 2018 (96.1±0.1 %) than 2019 (29.1±0.2 %). According to the measurements the ecological value decreases in Ildır Bay station. Kara Ada monitoring station baseline measurements were done in 2019, and the highest value of the shoot density and the horizontal rhizome (plagiotropic rhizome) were found as 75.8 ± 14.7 shoot/m² and 50.0 ± 0.2 %, respectively.

Several phenological studies of *Posidonia oceanica* meadows were made in Foça [20], Sığacık Bay [21], and Engeceli Bay [22] on the Aegean coasts of Turkey. The phenological studies of *P. oceanica* meadows from two shallow depths (1÷3 m and 4÷7 m) in the Sığacık Bay were made, and the highest values of the shoot density (max. 880 shoots/m²) and leaves (7420 leaves/ m²) was found at the 4÷7 m depth in December [21].

Three different depths (0÷5 m, 5÷10 m, and 10÷15 m) in Engeceli Bay were studied, and the highest value of the shoot density (max. 540±25 shoots/m²) was found at 0÷5 m depth [22].

Monitoring station of *P. oceanica* meadows was also established from two stations in Foça at two different depths (Toprak Su Camp station: 22.2 m, and Hamamlık station: 16.5 m) [20]. The lowest and highest values of the shoot density were found in Toprak Su Camp station (34 shoots/m² and 192 shoots/m²) than Hamamlık station (50 shoots/m² and 150 shoots/m²) in Foça [20]. According to this study, two monitoring station (Toprak Su Camp and Hamamlık) were found as the poor ecological status class.

Turbidity increase, limits the light penetration and restrains the photosynthesis of the meadows and causes a regression at lower limit [23]. The decline in shoot density of *P. oceanica* could indicate a withdrawal at lower limit in Ildır Bay station [24]. The reason for this is thought to be due to the aquaculture activities in the vicinity but it is not certain, more detailed research is needed for this purpose.

Conclusion

Posidonia oceanica is a sensitive species and, it is mainly affected by anthropogenic activities (domestic and industrial sewage outfalls, tourism, urbanization,

harbors, yachting, fish farm, etc.) in the last years. Monitoring studies of the *P. oceanica* meadows are very important, and the monitoring studies should be made to widespread in the Mediterranean coasts and Turkey.

These are preliminary results and it should be continued to monitor for future state of the *P. oceanica* meadows. As for effective monitoring, this should be done over a period of time depending on the objective. If it is for the quality of the environment the time should be at least 5÷8 years, for impact control of marine construction it is 1÷2 years [25].

Acknowledgements

The present study was carried out with the project called “Integrated Pollution Monitoring in Turkish Seas (ÇŞB/ÇEDİDGM-TÜBİTAK/MAM; 2017-2019)” supported by the Ministry of Environment and Urbanization of Turkey.

References

- [1] Buia M.C., Gambi M.C., Dappiano M. (2004) - *Seagrass systems*, In: Gambi M.C., Dappiano M. (eds), *Mediterranean marine benthos: a manual of methods for its sampling and study*, Biol. Mar. Medit. 11(suppl. 1), 133-183.
- [2] Relini G., Giaccone G. (2009) - *Priority habitats according to the SPA/BIO Protocol (Barcelona Convention) present in Italy*, Identification sheets. Biol. Mar. Medit. 16, 1-372.
- [3] Balestri E., Cinelli F., Lardicci C. (2003) - *Spatial variation in Posidonia oceanica structural, morphological and dynamic features in a northwestern Mediterranean coastal area: a multi-scale analysis*. Marine Ecology Progress Series 250, 51-60.
- [4] Mayot N., Boudouresque C.F., Leriche A. (2005) - *Unexpected response of the seagrass Posidonia oceanica to a warm-water episode in the North Western Mediterranean Sea*. Comptes Rendus Biologies 328(3), 291-296.
- [5] Boudouresque C.F., Jeudy de Grissac A., Meinesz A. (1984) - *Relations entre la sédimentation et l'allongement des rhizomes orthotropes de Posidonia oceanica dans la baie d'Elbu (Corse)*. In International Workshop on Posidonia oceanica Beds. Marseilles: GIS Posidonie publ (pp. 185-191).
- [6] Marbà N., Duarte C.M., Alexandra A., Cabaço S. (2004) - *How do seagrasses grow and spread*, European seagrasses: an introduction to monitoring and management, 11.
- [7] Gobert S., Cambridge M.T., Velimirov B., Pergent G., Lepoint G., Bouqueneau J.M., Dauby P., Pergent-Martini C., Walker D.I. (2007) - *Biology of Posidonia*, In Seagrasses: Biology, Ecology and Conservation, Springer, Dordrecht.
- [8] Marbà N., Duarte C.M. (1998) - *Rhizome elongation and seagrass clonal growth*, Marine Ecology Progress Series, 174, 269-280.
- [9] Kendrick G.A., Marbà N., Duarte C.M. (2005) - *Modelling formation of complex topography by the seagrass Posidonia oceanica*, Estuarine, Coastal and Shelf Science 65(4), 717-725.
- [10] Boudouresque C.F., Meinesz A. (1982) - *Découverte de l'herbier de Posidonie*, Cah. Parc nation. Port-Cros, Fr. 4, 1-79.
- [11] Astier J.M. (1984) - *Impact des aménagements littoraux de la rade de Toulon, liés*

- aux techniques d'endigage, sur les herbiers à Posidonia oceanica*, In: Boudouresque C.F., Jeudy de Grissac A., Olivier J. (eds), International Workshop on Posidonia oceanica beds, GIS Posidonie publ., Marseille, Fr. 1, 255-259.
- [12] Pérès J.M. (1984) - *La régression des herbiers à Posidonia oceanica*, In: Boudouresque C.F., Jeudy de Grissac A., Olivier J. (eds), International Workshop on Posidonia oceanica beds, GIS Posidonie publ., Marseille, Fr. 1, 445-454.
- [13] Gravez V., Nieri M., Boudouresque C.F. (1992) - *Surveillance de l'herbier de Posidonie de la baie du Prado (Marseille)*, Rapport de synthèse 1986-1992. Direction Générale des Services techniques de la Ville de Marseille and GIS Posidonie publ., Marseille, Fr.
- [14] Chessa L.A., Fresi E. (1994) - *Conservazione e gestione delle praterie di Posidonia*, In: Monbailliu X., Torre A. (eds), La gestione degli ambienti costieri e insulari del Mediterraneo, Edizione del Sole publ., Ital.
- [15] Bianchi C.N., Peirano A. (1995) - *Atlante delle Fanerogame marine della Liguria. Posidonia oceanica e Cymodocea nodosa*, Centro Ricerche Ambiente Marino, ENEA publ., La Spezia, Ital.
- [16] Pergent G., Pergent-Martini C., Boudouresque C.F. (1995) - *Utilisation de l'herbier à Posidonia oceanica comme indicateur biologique de la qualité du milieu littoral en Méditerranée: état des connaissances*, Mésogée 54, 3-27.
- [17] Pergent-Martini C., Pergent G. (2000) - *Are marine phanerogams a valuable tool in the evaluation of marine trace-metal contamination: example of the Mediterranean Sea?*, Int. J. Environ. Pollut. 13, 126-147.
- [18] Ruiz J.M., Romero J. (2003) - *Effects of disturbances caused by coastal constructions on spatial structure, growth dynamics and photosynthesis of the seagrass Posidonia oceanica*, Mar. Pollut. Bull. 46, 1523-1533.
- [19] Pergent G. (2007) - *Protocol for the setting up of Posidonia meadows monitoring systems*. MedPosidonie Programme/RAC/SPA-TOTAL Corporate Foundation for Biodiversity and the Sea; Memorandum of Understanding N°21/2007/RAC/SPA_MedPosidonie Nautilus-Okianos.
- [20] Akçali, B., Bizsel, K.C., Kabaoglu, G., Güçlüsoy, H. & Alaçam, Ö. (2008) - *Preliminary study of monitoring seagrasses (Posidonia oceanica) in Foça's Special Environmental Protected Area* 12 Underwater and Science Technologies Meeting, Ege University, 69-75.
- [21] Dural B. (2010) - *Phenological Observations on Posidonia oceanica (L.) Delile meadows along the coast of Akkum (Sigacik Bay, Aegean Sea, Turkey)*, J. Black Sea/Mediterranean Environment 16 (1), 133-144.
- [22] Koçak F., Uluturhan E., Gier G.Y., Önen S.A. (2011) - *Impact of environmental conditions on Posidonia oceanica meadows in the eastern Mediterranean Sea*, Indian Journal of Geo-Marine Sciences 40, 770-778.
- [23] Boudouresque C.F., Bernard G., Shili A., Verlaque M. (2009) - *Regression of Mediterranean seagrasses caused by natural processes and anthropogenic disturbances and stress: a critical review*. Bot. Mar., 52: 395-418.
- [24] Mayot N., Boudouresque C.F., Charbonnel E. (2006) - *Changes over time of shoot density of the Mediterranean seagrass Posidonia oceanica at its depth limit*. Biol. Mar. Medit., 13 (4): 250-254.
- [25] UNEP/MAP-RAC/SPA (2015) - *Guidelines for Standardization of Mapping and Monitoring Methods of Marine Magnoliophyta in the Mediterranean*. Christine Pergent-Martini, Edits., RAC/SPA publ., Tunis: 48 p. + Annexes.

HABITAT AND FLORA MONITORING IN THE REGIONAL NATURE RESERVE OF "PALUDE DEL CONTE E DUNA COSTIERA DI PORTO CESAREO" (PUGLIA, ITALY)

Leonardo Beccarisi¹, Cosimo Gaspare Giannuzzi¹, Giorgio D'Andria², Marco Greco²

¹Studio di Consulenza Ecologica, Via Verdi 13, 73048 Nardò (Italy)

phone +39 3209709895, e-mail: beccarisil@gmail.com

²Coordinamento Ambientalisti pro Porto Cesareo, Porto Cesareo (Italy)

Abstract – This study describes the results of the monitoring activity on habitats and plant species in the Regional Nature Reserve of "Palude del Conte e Duna Costiera di Porto Cesareo" (Puglia, Italy) and in the adjoining special areas of conservation (SACs). This activity was carried out in the period April-December 2018.

The methods followed the ISPRA guidelines concerning the monitoring of the Directive 92/43/EEC (Habitats) species and habitats. The activity combined field vegetation surveys and interpretation of orthophotos on a GIS system.

The resulting vegetation map represents 21 vegetation types. The habitat map was derived from the vegetation map and represents the spatial distribution of 18 Directive habitat types. The total cover of these habitat types is 444.0 ha, equal to 37.0 % of the study area. The priority types are in number of 5; they have a total cover of 91.8 ha, equal to 7.6 % of the study area.

In comparison with the previous available habitat maps of the study area, there is some substantial differences. Particularly, compared to the last map dating back to 2003, main results are the cover increase of rush saltmarshes (Natura 2000 code: 1410) and the cover decrease of steppes (Natura 2000 code: 6220*).

The study identifies the pressure and threat factors that negatively affect the conservation of habitats and provides management indications. All the sites used to access the beaches have been located and classified. 34 % of them were classified as highly critical for the conservation of dune habitats.

With reference to the flora, a number of 240 taxa was recorded, equal to 38 % of all taxa known for the study area. The new data allow to extend the list of well-known species of greater conservation interest for the study area. Exactly, there are 8 new noteworthy species, including the red-list species *Elatine macropoda* and *Lythrum thymifolia*.

Introduction

The Article 17 of the Habitats Directive regulates the need to conduct monitoring activities on habitats and species of Community interest. This monitoring is carried out by the EU's member states and, in the specific case of Italy, by the regions that have ministerial delegation in the environmental field. The monitoring results are used to report information relating to the conservation status of habitats and species, their trend, as well as the pressures and threats that affect the conservation of these ecological entities [17].

The conservation status of a habitat of Community interest is a concept defined by the Article 1 of the Habitats Directive, which also establishes the criteria for considering that status as satisfactory, based on structural (such as measurable areal properties) and functional properties. Similar criteria are also given for species.

In the Puglia Region (in the southern Italy), monitoring activities are encouraged in the context of specific administrative tools. In particular, the Prioritized Action Framework (PAF) of the period 2014-2020 prioritizes the measures to be implemented for the conservation of habitats and species of Habitats and Wild Birds directives. The Regional Regulation n. 6/2016 contains the conservation measures for the Special Area of Conservation (SACs) of Puglia. Both tools indicate that monitoring and updates are needed for all habitats and species of the EU directives.

The present study pursues the purposes of this regional regulation in a protected natural area in Puglia, and concerns a monitoring campaign carried out in 2018. The objectives of the study were to represent the spatial distribution of the habitats of the Directive, identify the main environmental factors that affect the conservation status of these habitats and acquire new information on the flora of greater conservation interest.

Materials and Methods

The Study Area

This study focused on a terrestrial area located in the municipality of Porto Cesareo. The study area is the result of the union of three partially overlapping protected areas, namely the Regional Nature Reserve of "Palude del Conte and Duna Costiera di Porto Cesareo" and the two SACs of "Palude del Conte, Dunes of Punta Prosciutto" (IT9150027) and "Porto Cesareo" (IT9150028), limited to the land and island surface falling within the municipal jurisdiction (Figure 1).

The study area has a coverage of 1200.7 ha, in the range of distance from the coast line of 0 ÷ 4.7 km and in the altitude range of 0 ÷ 46 m a.s.l. It covers 27 km of coast, which is partly rocky and low, and sandy for the rest, related to dune systems. There are three main wetlands. Having been subject to hydraulic reclamation in the last century, they are crossed by artificial canals connected to tidal basins. The main housing settlements, mainly agglomerations of summer houses and facilities for tourist accommodation, are located outside the study area. The inland potential vegetation is represented by holm oak woods; on the coast there are three series of vegetation, that is the hygrophilous, the psammophilous and the chasmophytic vegetation [8].

The study area is "well known" from a floristic point of view [1]. In fact, the botanical research that has been carried out in the past is numerous. Leaving aside the oldest studies, the progress on the floristic knowledge of the study area, as well as on vegetation and habitats, is divided into a series of stages which are the years 1978 [11], 1980 [19], 2003 [5] and 2007 [4]. Each of these researches proposes a habitat distribution map. The most recent synthesis [2] returns a landscape with a number of 16 habitat types of the Habitats Directive (including cave habitats) and with an overall vascular richness of 627 taxa.

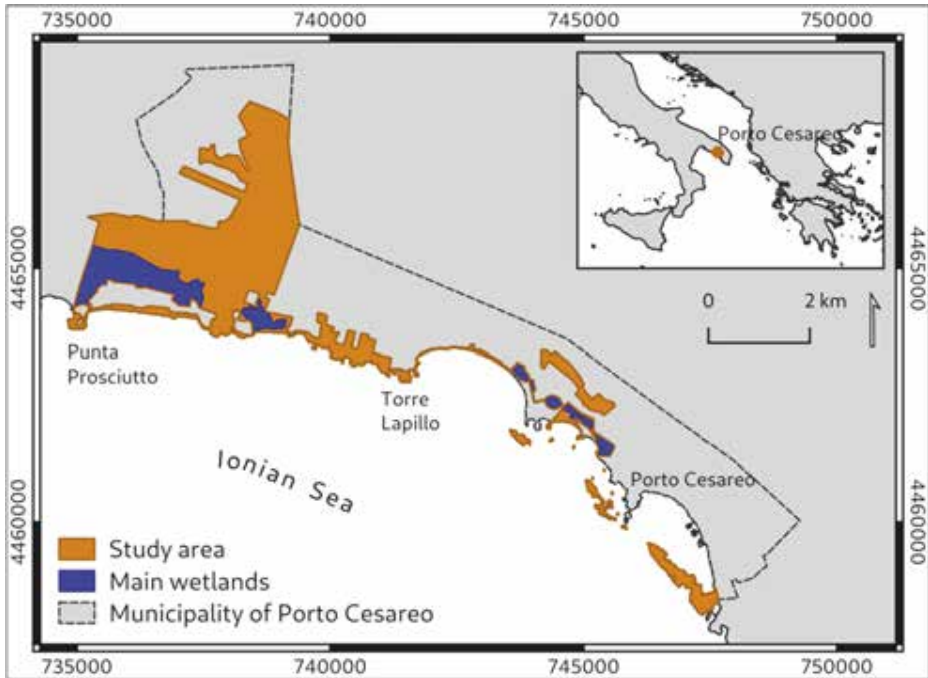

Figure 1 - The study area with the location of main wetlands (coordinate system UTM 33 WGS84).

Field data

Field surveys were carried out in the period April-December 2018, respecting the sampling guidelines of ISPRA [3, 13]. The vegetation surveys were conducted with the cover class method [10], which consists of positioning a rectangular plot on the ground, identifying all the vascular species present inside and assigning a cover value to each species according to the ordinal scale of abundance of Braun-Blanquet. The dimensions of the plots depend on the type of vegetation and are between 2 m² for small herbaceous vegetation and 16 m² for shrub vegetation [3, 10].

Plant specimens were determined in the laboratory with the use of [22, 25]. The nomenclature followed is that of An Archive for Botanical Data [20].

Protected species [23, 27], endangered species [6, 12, 24] and rare species have been treated as a particular category called *species of greater conservation interest*. Data on the origin and invasiveness of exotic species are taken from [16] for the Apulian flora.

During the surveys, evidence was also recorded on the presence of pressures and threats. While *pressures* are natural or anthropogenic factors that affect the conservation of habitats, *threats* are natural or anthropogenic potential factors. For this data, the European pressures / threats classification system used for the monitoring of species and habitats of EU directives has been adopted [17].

Data processing

Patches of different types of vegetation were identified and classified on the basis of field data and through visual photointerpretation of orthorectified aerial photographs from 2016. The resulting vegetation map illustrates the spatial distribution of the vegetation types. The definitions attributed to the vegetation types are based on the descriptions reported by [7], on an adequate compromise between semantic accuracy and cartographic precision, given the scale of the map.

The habitats map illustrates the spatial distribution of the habitat types of the Habitats Directive. It was elaborated through the reclassification of the vegetation map. The reclassification criteria are those defined by [7, 8, 14]. Marine and cave habitats, which have not been studied, are excluded.

With regard to the analysis of pressures and threats, a particular processing was conducted for the dune accesses. These accesses, which people use to reach the beaches, were located during the field surveys and through visual photointerpretation. The accesses have been classified according to the danger they represent for the local conservation of habitats (pressure). The pressure was expressed on an ordinal scale with two values: high and low. The classification is based on the following criteria, assessed empirically and jointly: the length of the passage (long passage → high pressure), the width of the passage (wide passage → high pressure), the depth of the passage with respect to the top of the dune (deep passage → high pressure), local density of accesses (very close accesses → high pressure), proximity to priority habitats (accesses adjacent to habitat 2250 * → high pressure), presence / absence of a footbridge (absence of footbridge → high pressure).

Field data were managed with the anArchive for Botanical Data system (www.anarchive.it) [20]. The cartographic processing and the areal analysis were carried out with the software QGIS ver. 3.4 and GRASS ver. 7.2.

Results

71 vegetation surveys were carried out. The vegetation map consists of 21 vegetation types. The types with the greatest coverage are communities with weeds of the cultivated fields (30.5 % of the study area), Mediterranean bush (19.8 %), holm oak wood (10.0 %), reed-bed (8.7 %) and anthropogenic nitrophilic communities (7.6 %).

The habitats map is made up of 15 classes, corresponding to a total of 18 habitat types of the Directive. Indeed, some habitat types are grouped into a single class, since they constitute mosaics that cannot be resolved spatially at the scale of the map. The total coverage of the habitats of the Directive amounts to 444.0 ha (equal to 37.0 % of the study area) (Table 1). The priority types are 5; they have a total coverage of 91.8 ha (equal to 7.6 % of the study area).

With reference to the flora, a total of 240 taxa were detected. Among the various species of greater conservation interest, 8 had never been observed previously for the area. These are the endangered species *Elatine macropoda* Guss. and *Lythrum thymifolia* L., and the rare species *Juncus capitatus* Weigel, *Lysimachia minima* (L.) U.Manns & Anderb., *Lythrum borysthenicum* (Schrank) Litv., *Ranunculus saniculifolius* Viv., *Silene niceensis* All. and *Solenopsis laurentia* (L.) C. Presl.

The pressures/threats detected for the different habitat types are described in Table 2.

Table 1 - The habitat types in the study area, with their respective coverage values. The asterisk next to the Natura 2000 code designates the priority types.

Habitat types of the Habitats Directive	Area (ha)	Area (%)
1150*: Coastal lagoons	23,6	2,0
1210: Annual vegetation of drift lines	16,7	1,4
1240: Vegetated sea cliffs of the Mediterranean coasts with endemic <i>Limonium</i> spp.	40,6	3,4
1410: Mediterranean salt meadows (<i>Juncetalia maritimi</i>)	104,9	8,7
1310: <i>Salicornia</i> and other annuals colonizing mud and sand; 1420: Mediterranean and thermo-Atlantic halophilous scrubs (<i>Sarcocornetia fruticosi</i>)	23,9	2,0
2110: Embryonic shifting dunes; 2120: Shifting dunes along the shoreline with <i>Ammophila arenaria</i> (white dunes)	1,7	0,1
2230: <i>Malcolmietalia</i> dune grasslands; 2240: <i>Brachypodietalia</i> dune grasslands with annuals	25,7	2,1
2250*: Coastal dunes with <i>Juniperus</i> spp.	16,8	1,4
2260: <i>Cisto-Lavanduletalia</i> dune sclerophyllous scrubs	0,4	0,0
3170*: Mediterranean temporary ponds	0,6	0,0
3260: Water courses of plain to montane levels with the <i>Ranunculion fluitantis</i> and <i>Callitriche-Batrachion</i> vegetation	1,5	0,1
6220*: Pseudo-steppe with grasses and annuals of the <i>Thero-Brachypodietea</i>	49,7	4,1
6420: Mediterranean tall humid herb grasslands of the <i>Molinio-Holoschoenion [pro parte]</i>	17,0	1,4
7210*: Calcareous fens with <i>Cladium mariscus</i> and species of the <i>Caricion davallianae</i>	1,1	0,1
9340: <i>Quercus ilex</i> and <i>Quercus rotundifolia</i> forests	119,8	10,0
Total	444,0	37,0

Table 2 - Pressures / threats detected and corresponding affected habitat types.

Pressures / threats	Habitat types
A02.03: Grassland removal for arable land	6220*
A04.03: Abandonment of pastoral systems, lack of grazing	6220*
D01.03: Car parks and parking areas	1310, 1410, 1420, 6420
E01.02: Discontinuous urbanisation	1210, 1310, 1410, 1420, 2110, 2120, 2230, 2240, 2250*, 6220*, 6420
G05.01: Trampling, overuse	1210, 1310, 1410, 1420, 2110, 2120, 2230, 2240, 2250*, 6420
H05.01: Garbage and solid waste	1150*, 2110, 2120, 2230, 2240, 2250*, 3260
I01: Invasive non-native species	1310, 1410, 1420, 2120, 2230, 2240, 2250*, 6420
I02: Problematic native species	1310, 1410, 1420, 6420
J02.01: Landfill, land reclamation and drying out, general	1150*, 3260

The detected problematic native and invasive non-native species (to which the pressures / threats I01 and I02 refer) are the invasive neophytes *Ailanthus altissima* (Mill.) Swingle, *Carpobrotus edulis* (L.) N.E. Br., *Erigeron bonariensis* L., *Euphorbia maculata* L., *Euphorbia prostrata* Aiton, *Oxalis pes-caprae* L., *Symphyotrichum squamatum* (Spreng.) G.L. Nesom, the casual archeophyte *Phoenix dactylifera* L., and the locally introduced problematic autochthonous *Chamaerops humilis* L.

106 accesses have been identified on the dunes (to which pressures / threats G05.01 refers), 34 % of these have been classified as determining a high pressure on habitats.

Discussion

According to the Article 1 of the Habitats Directive, cover change is one of the criteria for assessing the conservation status of a habitat. Comparing maps from different years is a suitable method for this analysis. Since a historical series of vegetation maps has been available for the study area since 1978, this seems a advantageous situation which occurs only in a few geographical areas. Nevertheless, the comparison between these maps turned out to be an operation not without difficulties.

Some of these difficulties are intrinsic to classification system and analysis scale of each study. Habitat overlaps, mosaics of several habitat types and "over-complication" in habitat definition are some of the known causes [15] which introduce uncertainty into the classification work of each researcher. Even more important is the difference between the sampling designs. The lack of a standardized sampling design, the same for all the studies, makes it difficult to establish whether the discrepancy between the data corresponds to a "transformation of the ecological system" or an "improvement of the knowledge system". Despite these difficulties, considerations are provided below on the differences found in the data extracted from the maps of the various periods, plausibly trying to discriminate "transformations of the ecological system" from "improvements of the knowledge system".



Figure 2 - Replacement of habitat 6220* (on the right) by the cultivation.

Compared to the map of 2003 [5], there's an increase in the coverage of 1410 type of 12.0 ha. This is an interesting result, due to the replacement of the reed-bed in rush saltmarsh, apparently a positive response to a more rigorous conservation regime.

Compared to the map of 2003 [5] there's a 20.8 ha reduction in coverage of the 6220* type. This is a value attributable to the tillage of ancient land managed with extensive grazing in favor of agriculture (Figure 2). This transformation concerns the innermost areas, in response to the loss of the economic driver of traditional grazing.

With regard to the 2230 / 2240 types, there's an increase of 23.4 ha compared to 2003. Indeed, previous studies underestimated these habitat types, as well as the 2260, 3170*, 3260, 6420 and 7210*.

With reference to the flora, the 240 recorded taxa correspond to 38 % of the floristic richness known for the study area [2]. The new data extend the list of species of greatest conservation interest. *Elatine macropoda* is a national red-list species with critically (CR) endangered status [24]. *Lythrum thymifolia* is a regional red-list species with endangered (EN) status [12]. With reference to the records of *Ranunculus saniculifolius* and *Silene niceensis*, these are the first data of the presence of these species in Salento (consult [21] for a comparison).

With reference to pressures and threats, the most represented type is discontinuous urbanization (E01.02). The expansion rate of the urbanized area has decreased in recent years, but the effects of past expansion weigh heavily on the conservation of natural patches, remained relatively small and fragmented in the matrix of buildings and infrastructures. How to conserve these residual natural patches is one of the main challenges for the administration body of the protected areas.

Car parks and parking areas (D01.03), Trampling, overuse (G05.01), the presence of Garbage and solid waste (H05.01), the introduction of Invasive non-native species (I01) inside the shores are all pressures / threats related to the tourist use of the coast. 34 % of the dune accesses are highly critical for the conservation of dune systems. The restoration of vegetation in these sites certainly represents an urgent measure to be put in place to protect dune habitats.

The Grassland removal for arable land (A02.03) and the Abandonment of pastoral systems, lack of grazing (A04.03) are pressures / threats related to the loss of the economic value of traditional grazing. The requalification of this activity is an urgent measure to be put in place to protect the habitat type 6220*.

Conclusion

The results achieved by the study increase the ecological knowledge of the protected areas of Porto Cesareo, allow to evaluate the conservation status of the habitats, highlight the environmental detrimental factors and direct towards the adoption of particular conservation measures.

On methodological issues, the difficulty of comparing the new habitat map with those developed in past years was found. The need to develop and adopt a standardized monitoring method over the long term is evident. Sample selection methods [18] and remote sensing [26] are relevant tools that must be taken into consideration for an effective monitoring plan. In this sense, the ISPRA manual [3] provides only a partial guide since, although full of fundamental information on how to study habitats, it does not propose a standardized sampling design.

Acknowledgments

The authors would like to thank the Coordinamento Ambientalisti pro Porto Cesareo's affiliates Fabiana Musardo, Sara Valentino, Antonietta Cesari and Francesca Lombardo for their support during the field surveys.

References

- [1] Albano A., Accogli R., Marchiori S., Medagli P., Mele C. (2005) - *Stato delle conoscenze floristiche in Puglia*, Stato delle Conoscenze sulla Flora Vascolare d'Italia, Palombi Editori, Roma, pp. 185–190.
- [2] Albano A., Arzeni S., Beccarisi L., Ernandes P., Marzano G., Minonne F., Turco A., Medagli P. (2010) - *Aspetti della biodiversità nella Riserva Naturale Orientata Regionale "Palude del Conte e Duna Costiera-Porto Cesareo"*, Edizioni Grifo, Lecce.
- [3] Angelini P., Casella L., Grignetti A., Genovesi P. (Eds) (2016) - *Manuali per il monitoraggio di specie e habitat di interesse comunitario (Direttiva 92/43/CEE) in Italia: habitat*, ISPRA, Serie Manuali e linee guida, 142/2016.
- [4] Beccarisi L., Ernandes P., Zuccarello V. (2007) - *Zona costiera del Salento: cambiamenti degli habitat prioritari, d'interesse comunitario e d'interesse regionale negli ultimi 50 anni. Il tratto di costa ionica di Porto Cesareo come caso di studio*, Fitosociologia 44 (1), 139–155.
- [5] Beccarisi L., Medagli P., Minonne F., Marchiori S. (2003) - *Studio floristico-vegetazionale finalizzato alla elaborazione di una proposta di ripermutazione dei siti di importanza comunitaria (SIC) del comune di Porto Cesareo (prov. di Lecce)*, Comune di Porto Cesareo.
- [6] Bilz M., Kell S.P., Maxted N., Lansdown R.V. (2011) - *European Red List of Vascular Plants*, Publications Office of the European Union, Luxembourg.
- [7] Biondi E., Blasi C. (2015) - *Prodromo alla vegetazione d'Italia*, [online] URL: <http://www.prodromo-vegetazione-italia.org>.
- [8] Biondi E., Blasi C., Burrascano S., Casavecchia S., Copiz R., Del Vico E., Galdenzi D., Gigante D., Lasen C., Spampinato G., Venanzoni R., Zivkovic L. (2009) - *Manuale Italiano di interpretazione degli habitat della Direttiva 92/43/CEE*, [online] URL: <http://vnr.unipg.it/habitat/>.
- [9] Biondi E., Casavecchia S., Beccarisi L., Marchiori S., Medagli P., Zuccarello V. (2010) - *Le serie di vegetazione della Regione Puglia*, La Vegetazione d'Italia, Palombi & Partner, Roma, pp. 391–409.
- [10] Bonham C.D. (2013) - *Measurements for Terrestrial Vegetation, Second Edition*, John Wiley & Sons.
- [11] Caniglia G., Chiesura Lorenzoni F., Lorenzoni G.G., Marchiori S., Razzara S., Tornadore Marchiori N. (1978) - *Carta della vegetazione di Torre Colimena, Salento, Puglia meridionale*, C.N.R. Collana P.F. Promozione della qualità dell'ambiente AQ/1/8, Roma.
- [12] Conti F., Manzi A., Pedrotti F. (1997) - *Liste rosse regionali delle piante d'Italia*, Società Botanica Italiana e WWF Italia, Roma.
- [13] Ercole S., Giacanelli V., Bacchetta G., Fenu G., Genovesi P. (Eds) (2016) - *Manuali*

- per il monitoraggio di specie e habitat di interesse comunitario (Direttiva 92/43/CEE) in Italia: specie vegetali*, ISPRA, Serie Manuali e linee guida, 140/2016.
- [14] European Commission DG Environment (2013) - *Interpretation Manual Of European Union Habitats, EUR 28*, European Commission DG Environment.
- [15] Evans D. (2006) - *The Habitats of the European Union Habitats Directive*, Biology and Environment: Preceedings of the Royal Irish Academy 106B (3), 167–173.
- [16] Galasso G., Conti F., Peruzzi L., Ardenghi N.M.G., Banfi E., Celesti-Grapow L., Albano A., Alessandrini A., Bacchetta G., Ballelli S., Bandini Mazzanti M., Barberis G., Bernardo L., Blasi C., Bouvet D., Bovio M., Cecchi L., Del Guacchio E., Domina G., Fascetti S., Gallo L., Gubellini L., Guiggi A., Iamónico D., Iberite M., Jiménez-Mejias P., Lattanzi E., Marchetti D., Martinetto E., Masin R.R., Medagli P., Passalacqua N.G., Peccenini S., Pennesi R., Pierini B., Podda L., Poldini L., Prosser F., Raimondo F.M., Roma-Marzio F., Rosati L., Santangelo A., Scoppola A., Scortegagna S., Selvaggi A., Selvi F., Soldano A., Stinca A., Wagensommer R.P., Wilhalm T., Bartolucci F. (2018) - *An updated checklist of the vascular flora alien to Italy*, Plant Biosystems 152, 179–303.
- [17] Genovesi P., Angelini P., Bianchi E., Dupré E., Ercole S., Giacanelli V., Ronchi F., Stoch F. (2014) -*Specie e habitat di interesse comunitario in Italia: distribuzione, stato di conservazione e trend*, ISPRA, Serie Rapporti, 194/2014.
- [18] Gitzen R.A., Millsbaugh J.J., Cooper A.B., Licht D.S. (Eds) (2012) -*Design and Analysis of Long-term Ecological Monitoring Studies*, Cambridge University Press.
- [19] Lorenzoni G.G., Caniglia G., Marchiori S., Razzara S. (1980) - *Carta della vegetazione di Maruggio, S. Pietro e S. Isidoro (Salento, Puglia meridionale)*, C.N.R.Collana P.F. Promozione della qualità dell'ambiente AQ/1/123, Roma.
- [20] Lucarini D., Gigante D., Landucci F., Panfili E., Venanzoni R. (2015) -*The anArchive taxonomic Checklist for Italian botanical data banking and vegetation analysis: Theoretical basis and advantages*, Plant Biosystems 149, 958–965.
- [21] Mele C., Medagli P., Accogli R., Beccarisi L., Albano A., Marchiori S. (2006) - *Flora of Salento (Apulia, Southeastern Italy): an annotated checklist*. Flora Mediterranea 16, 193–245.
- [22] Pignatti S. (2017-2019) - *Flora d'Italia, Seconda edizione*, Edagricole, Bologna.
- [23] Rossi G., Montagnani C., Gargano D., Peruzzi L., Abeli T., Ravera S., Cogoni A., Fenu G., Magrini S., Gennai M., Foggi B., Wagensommer R.P., Venturella G., Blasi C., Raimondo F.M., Orsenigo S. (Eds) (2013) - *Lista Rossa della Flora Italiana. I. Policy Species e altre specie minacciate*, Comitato Italiano IUCN e Ministero dell'Ambiente e della Tutela del Territorio e del Mare.
- [24] Scoppola A., Spampinato G. (Eds) (2005) - *Atlante delle specie a rischio di estinzione*, Stato delle conoscenze sulla flora vascolare d'Italia, Palombi Editori, Roma.
- [25] Tutin T.G., Heywood V.H., Burges N.A., Valentine D.H., Walters S.M., Webb D.A. (1968-1983) - *Flora Europaea*, Cambridge University Press, Cambridge.
- [26] Vanden Borre J., Paelinckx D., Múcher C.A., Kooistra L., Haest B., De Blust G., Schmidt A.M. (2011) - *Integrating remote sensing in Natura 2000 habitat monitoring: Prospects on the way forward*, Journal for Nature Conservation 19, 116–125.
- [27] Zito P., Sajeva M., Rocco M. (2008) - *Le specie vegetali italiane presenti nella normativa CITES dell'Unione Europea*, Informatore Botanico Italiano 40, 43–69.

A NEW TRANSPLANTING METHOD OF *POSIDONIA OCEANICA* (Linnaeus) Delile, 1813 PLANTS

Roberto Bedini¹, Marco Bedini¹, Elisa Salvadori¹

¹Istituto di Biologia ed Ecologia Marina, Piazza G. Bovio ¾, 57025, Piombino (LI),
phone +39 0565 225196, fax +39 0565 227021, e-mail: bedini@biomare.it; museomare@biomare.it

Abstract - The seabed of the port of Piombino was to be modified, increasing the depth, to allow the arrivals of cruise ships. The great problem to overcome was the presence, in the port area, of *Posidonia oceanica* (Linnaeus) Delile, 1813 meadows.

P. oceanica is a protected species by the Berne Convention (Annex 1), by the Barcelona Convention (SPA/BIO protocol) and by the Habitat Directive 1992/43/EEC. Initially, the project was to remove and grind the plants of the meadow causing a considerable environmental damage. The Port Authority of Piombino asked the Institute of Marine Biology and Ecology to study an alternative project.

Having studied the *P. oceanica* prairies and their ecology for over twenty years along the coast of all Tuscany and knowing the short results of the methods of replanting *P. oceanica* plant by plant we decided to transplant 340 clods of *P. oceanica* of 2 m² to a nearby meadow (fig. 1).

Our transplanting method has been used in the Gulf of Follonica (Italy).

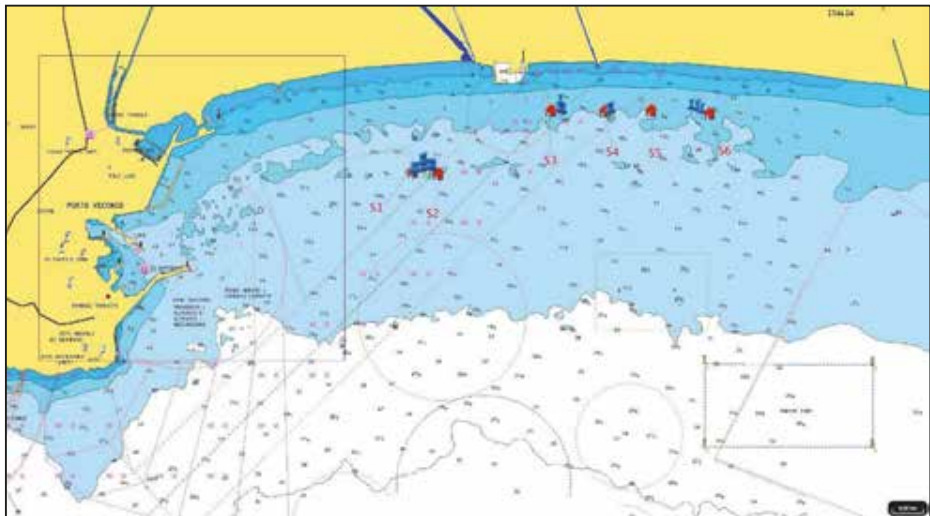

Figure 1 - Map of the replanting areas. The red symbols, from S1 to S6, represent the reference areas while the blue symbols represent where the dredger deposited the clods of *P. oceanica*.

Introduction

P. oceanica meadows are in regression across the Mediterranean sea because of anthropic activities which cause the consequent retreat of the beaches since the meadows dampen the impact force of the waves.

P. oceanica is a plant and not a seaweed so it is closely related to the substrate of the settlement [6]. If we transfer the plants from one bottom to another the plant, which has fed on the same type of sea bottom for many years, must necessarily try to activate a series of adaptations very difficult to find.

On the contrary, if we can carry hundreds of plants together with 2 m x1.50 m x1.20 m meters of substrate settlement, where they have lived for many years, it will be easier for them to adapt (fig. 2). Another very serious problem to be solved is tearing the plant from the bottom because it anyway suffers a damage.



Figure 2 - Clod of *P. oceanica*.

Material and Methods

Before the clods are moved from the seabed, an underwater biologist captured the species of the vagile fauna living on or among the leaves of the *P. oceanica* by a hand-operated plankton net (fig. 3).

The transfer of the *P. oceanica* clods was carried out using a spilt-barge motor ship (fig. 4). This ship opens and lets water enter where the clods will be positioned (fig. 5). The clods are removed from the seabed by the boat crane.



Figure 3 - Biologist during sampling with the hand-operated plankton net.



Figure 4 - Spilt-barge motor ship used for the removal of clods.

In this way all the marine organisms living on the rizoms, between the leaves or in the “matte”, remain alive until the positioning of the clods on the seabed. The clods were positioned both close to the upper limit of the meadow and in the intermatte channels to be more protected from the force of the waves (fig. 6).



Figure 5 - Opening which enable the water to fill the housing for the clods.



Figure 6 - Clod provided by a signaling buoy positioned in an intermatte channel.

To find the exact point where to drop the clod an underwater biologist identified the appropriate area of the bottom and signalled it with buoys sent to the surface (fig. 7).

The clods were anchored to the sandy bottom by four pegs 1.5 m long (fig. 8).



Figure 7 - The red arrows highlight the presence of the buoys which signalled the exact area where to deposit the clod.



Figure 8 - Anchoring of the clod to the sandy substrate.

Results

The results were that with our method 92 % of the plants survived. The most important result obtained has been that during the three years many new plants have sprung up from most of the clods, since vegetative reproduction by stolonization is the most common (fig. 9).



Figure 9 - The yellow arrows indicate the new plants which have expanded from the clod.

Each clod was placed in the upper limit in the patches of plants or in front of the prairie upper limit. The clods either were anchored to the bottom by four pegs 1.50 m long carrying a small numbered little float for its identification during the monitoring campaigns.

The fact that new plants were born meant that the *P. oceanica* clods have perfectly adapted to the new settlement ground having brought part of the old seabed with them.

Moreover, a great conservation of the species that live on the leaves, in the mat and the species in the juvenile stages was observed.

Discussion

For the first time, hundreds of *P. oceanica* plants in one block were transferred and above all together with the substrate where they had lived for many years.

P. oceanica forms an extremely important ecosystem throughout the Mediterranean sea that the Habitat Directive has designated as a priority habitat. For this reason, transplants must be carried out only in case of need without alternatives, because taking tens and sometimes hundreds of thousands of plants from one site to another causes a damage to the former.

Instead for absolutely necessary works such as the expansion of the breakwater of Piombino harbour to an area where there is a *P. oceanica* meadow, part of it will be destroyed so the transfer of plants is necessary as a damage mitigation.

Since one of the most important functions of the meadows is to act as nursery for many marine species, our method of catching hundreds of invertebrates (fig. 10) and vertebrates (fig. 11) to transfer them to the areas where the clods are placed is the first transplanting method to care about this very important meadow function.

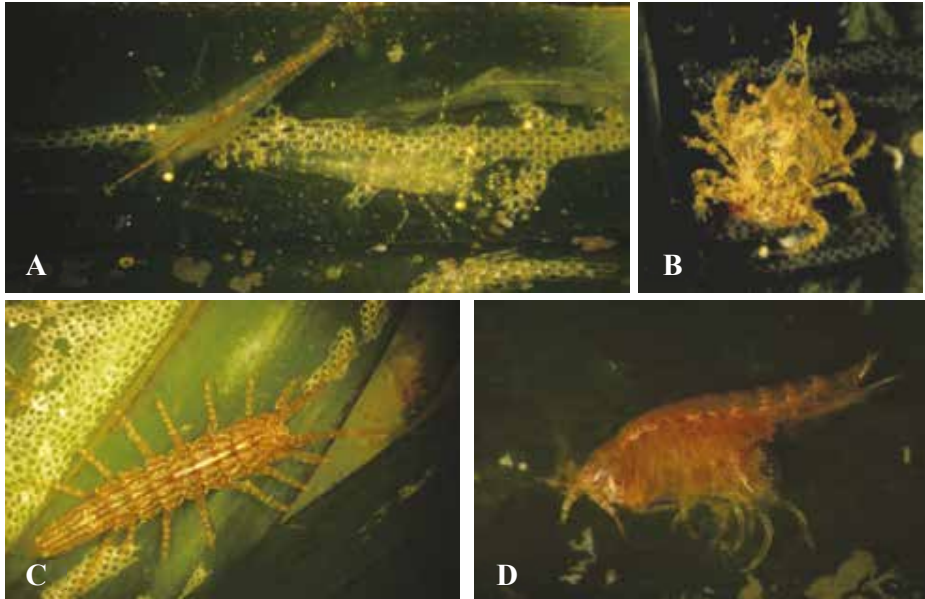

Figure 10 - Examples of invertebrate species sampled on 1 cm wide *P. oceanica* leaves: A) *Hippolyte inermis* Leach, 1816, B) *Sirpus zariquieyi* Gordon, 1953, C) *Idotea granulosa* Rathke, 1843, D) *Lysianassa costae* H. Milne Edwards, 1830.



Figure 11 - Example of vertebrate sampled on 1 cm wide *P. oceanica* leaves: *Diplecogaster bimaculata* (Bonnaterre, 1788)

Conclusions

The criticality of the use of single plants removed from the meadow to be transplanted is that they are easily damaged and above all they lose all the species that use it as a nursery, because they are individuals of a few millimeters. Another critical issue in reforestation plant by plant is that the plant is removed from a very particular and specific substrate where it used to feed for hundred, sometimes thousands of years and it must adapt to a sometimes extremely different substrate.

On the contrary, if we transplant clods of 2 m² with 2 m x 1.50 m x 1.20 m of substrate settlement the plants that continue to live in their original settlement are not damaged. Another advantage in transplanting clods with a large sediment mass is that they retain the species which live among the leaves but also those which live inside the “matte” (fig. 12).



Figure 12 - Examples of species sampled on 1 cm wide *P. oceanica* leaves: A) *Leptochelia savignyi* (Krøyer, 1842), B) *Upogebia tipica* (Nardo, 1869).

Acknowledgements

Thanks to the Port Authority of Piombino for supporting the research and to Arianna Trafeli for the compilation of the research text.

References

- [1] Bedini R., Bedini M., Bonechi L., Piazzini L. (2015) - *Patterns of spatial variability of mobile macro-invertebrate assemblages within a Posidonia oceanica meadow*, Journal of Natural History, Vol. 49, Nos. 41-42, 2559-2581.
- [2] Bedini R., Canali M. G., Bertuccelli M. (2002) - *Epiphytic communities on Posidonia oceanica (L.) Delile leaves along the North Tyrrhenian coasts (N.W. Mediterranean Sea, Italy)*, Mediterranean Science, 4(2), 99-114.
- [3] Bedini R., Nannelli A., Battistini F. (2013) - *Restoration of Posidonia oceanica (L.) Delile meadows: is there an effective methodology?*, Journal of Life Sciences, Vol 7(7), 722-726.

- [4] Bedini R., Nannelli A., Giachini F., Maestrini M., Boccia B. (2006) - *Indagine preliminare sulle praterie di Posidonia oceanica (L.) Delile antistanti Ansedonia e Talamone (Grosseto)*, Proceedings of Codice Armonico, Primo Congresso Regionale di Scienze Naturali fascia Toscana Mediterranea, Castiglioncello (LI), Italy, 17-19 February 2006, pp. 141-144.
- [5] Bedini R., Pertusati M., Batistini F., Piazzì L. (2011) - *Spatial and temporal variation of motile macro-invertebrate assemblages associated with Posidonia oceanica meadows*, Acta Adriatica, Vol. 52(2), 201-214.
- [6] Pergent-Martini C., Leoni V., Pasqualini V., Ardizzone G.D., Balestri E., Bedini R., Belluscio A., Belsher T., Borgf J., Boudouresque C.F., Boumaza S., Bouquegneau J.M., Buia M.C., Calvo S., Cebrian J., Charbonnel E., Cinelli F., Cossu A., Di Maida G., Dural B., Francour P., Gobert S., Lepoint G., Meinesz A., Molenaar H., Mansour H.M., Panayotidis P., Peirano A., Pergent G., Piazzì L., Pirrotta M., Relini G., Romero J., Sanchez-Lizaso J.L., Semroud R., Shembri P., Shili A., Tomasello A., Velimirov B. (2005) - *Descriptors of Posidonia oceanica meadows: Use and application*, Ecological Indicators, vol. 5, iss. 3, 213-230.

A DRONE'S EYE VIEW: A PRELIMINARY ASSESSMENT OF THE EFFICIENCY OF DRONES IN MAPPING SHALLOW-WATER BENTHIC ASSEMBLAGES

Andrea Francesca Bellia*, Julian Evans, Sandro Lanfranco
Department of Biology, University of Malta, Msida, MSD2080, Malta
*phone +356 9919 3606, e-mail: andrea-francesca.bellia.17@um.edu.mt

Abstract – This study represents a preliminary assessment of the efficiency of consumer-level drones to survey shallow-water benthic cover (0-5m depth). We hypothesised that the use of a drone to map benthic assemblages would reduce the duration, cost, and manpower requirements, while increasing accuracy, relative to manual survey techniques.

A DJI Mavic 2 Pro drone was used to survey four bays in Malta by obtaining a high-altitude photo for each bay. This was then processed via *k*-means clustering to generate a pseudocolour image (PCI). The value of *k* corresponded to the number of benthic cover classes (BCCs), which was determined upon inspection of the original aerial image. Since *k* was dependent on the respective benthic complexity of each bay, the *k* value varied from site to site.

Each site was also mapped using manual survey techniques to enable comparison of the relative representation of BCCs between manual and drone-based methods. Data from manual surveys were obtained from transects spaced *ca.* 10 m apart, where the number of transects taken was dependent on the size of the respective site.

The correspondence between the two survey methods was determined using Principal Component Analysis (PCA) on the BCC relative cover of each site. Results obtained indicated a statistically significant positive correlation between the relative cover of BCCs in maps produced through drone and manual surveys ($r=0.845$, $p<0.0001$).

The relative efficiency of the two survey methods was assessed by comparing the area surveyed per man hour (m^2h^{-1}), where the automated drone survey method was significantly more efficient in all four sites. The drone survey was also more accurate than the manual survey, in that it mapped the entire area without the need for any interpolation between transects. This suggests that while manual surveys are a good approximation of the field situation, PCIs are capable of analysing benthic cover to give results of superior accuracy and coverage, but in a much shorter time, and without bias.

The only real limitation with regards to using drones for mapping purposes is the weather, since the drone cannot be flown in rainy conditions, and waves caused by strong winds obscure the benthos. The time of day at which the drone is flown is also a factor due to the sun's glare on the water's surface, which also obscures the benthos beneath. In addition, aerial imagery can only be used for mapping of benthic assemblages in very shallow waters and requires high water transparency.

Introduction

Rapid and accurate surveys to map benthic assemblages in shallow water are a fundamental requirement of several coastal monitoring programmes [4]. The combination

of speed and accuracy would permit more frequent surveys, increasing the probability of early detection of any environmental change [2]. In most cases, such monitoring programmes have utilised ground-based field survey techniques, where observers map benthic assemblages by sampling along transect lines and interpolating data to characterise the intervening areas. This method is rather slow, labour-intensive, and relatively imprecise, as it makes assumptions about the intervening areas.

A possible solution to these constraints is the use of a small unmanned aerial vehicle (drone) to survey and image areas from an altitude of tens or hundreds of metres. This could make the process more rapid than a manual survey, with comparable or increased accuracy. The increased availability of low-cost consumer drones with imaging capability of sufficiently high quality has propelled the use of drones into the mainstream and brought with it a need for new survey protocols to take advantage of this technology. This study aims to assess consumer-level drone efficiency to survey shallow-water benthic cover (0÷5 m depth) in the coastal zone. We hypothesise that the use of a drone to map benthic assemblages would reduce the duration, cost, and manpower requirements, while increasing accuracy, relative to manual survey techniques.

The principal questions addressed were the following:

- (1) Are drone-based surveys faster and more accurate than manual field surveys over equivalent areas?
- (2) Does benthic heterogeneity affect the relative efficiency of drone-based and manual surveys?

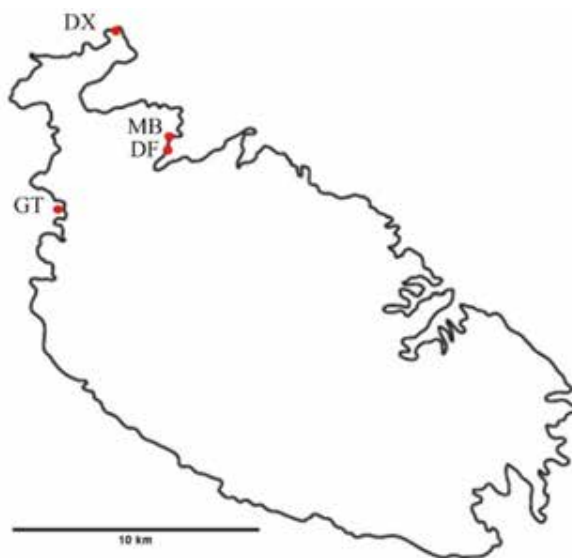

Figure 1 - Map of Malta, indicating locations of each Site of Study (SoS): Dahlet ix-Xmajjar (DX), Mistra Bay (MB), Dahlet il-Fekruna (DF) and Għajn Tuffieħa (GT). Scale bar bottom left, and North to the top of the image.

Materials and Methods

The study was based on photographic drone surveys of four sites of study (SoS) in Malta: Dahlet ix-Xmajjar (DX), Mistra Bay (MB), Dahlet il-Fekruna (DF) and Ghajn Tuffieħa (GT) (Figure 1). Aerial photographs of each SoS acquired from the drone were processed into pseudocolour images (PCIs) showing benthic assemblages. These were subsequently verified through ground-truthing in the field.

All aerial imagery was captured using a DJI Mavic 2 Pro drone (Da-Jiang Innovations Science and Technology Co. Ltd., Shenzhen, China) equipped with a Hasselblad L1D-20c camera. The camera had a Field of View of approximately 77°, and a 20MP 1” sensor yielding images with a resolution of 5472 pixels x 3648 pixels. The drone was generally flown at around 08:00 h, as the low angle of incidence of sunlight at this time reduced the glare on the sea surface. Flying the drone at other times of day was also possible on windless and overcast days, due to the absence of glare or rippling of the sea surface. The drone was flown to an altitude which encompassed the whole SoS for imaging in DNG and JPEG formats. The altitude varied according to the size of the SoS.

The processing workflow carried out during this study was adapted from one described for terrestrial vegetation mapping [1]. The aerial images were visually inspected to estimate the number of different Benthic Cover Classes (BCCs) in each SoS. This value was assigned to the variable k that was then used during the image processing phase. Images were subsequently segmented via k -means clustering in ImageJ [5] to produce the respective PCIs for each SoS. In this type of cluster analysis, the user supplies a predetermined number of clusters (k) to be produced. The algorithm converges towards clusters in which the within-group variance is much smaller than the between-group variance.

In the context of the images being processed, the algorithm identifies areas with similar chromatic properties, and groups them into ‘clusters’, each approximating a BCC. This reductive procedure was iterative and continued until the requisite number of clusters had been reached [3]. This gave a PCI with k colours, in which each colour corresponded to a different BCC. PCIs were then inspected and compared with the original aerial photo. The k value which best reflected the benthic complexity was then used for the rest of the analysis. It was assumed that each colour on the map corresponded to a different BCC. Following image analysis, validation of the PCIs was carried out. This was done by reconciling BCCs in the PCIs of each SoS with direct field survey results, at depths of 5 m or less.

Each SoS comprised one or more BCCs. The BCCs were initially loosely based on those described for the Tyrrhenian Sea around the Tuscan Archipelago [7] and modified accordingly. Each BCC was identified on the basis of its dominant cover but was not exclusive of other cover classes. The BCCs identified were: Bare exposed rock (BER), Bare sand (BS), Bare submerged rock (BSR), Dead matte (DM), Juvenile *Posidonia* (JP), *Posidonia* meadow (PM) and Rock with photophilic algae (RPA). The percentage cover of each BCC in the PCI was calculated directly from the image analysis program. The percentage cover of the benthic assemblages in the aerial images was estimated by superimposing a virtual grid on the photograph in ImageJ and calculating the percentage coverage of each BCC.

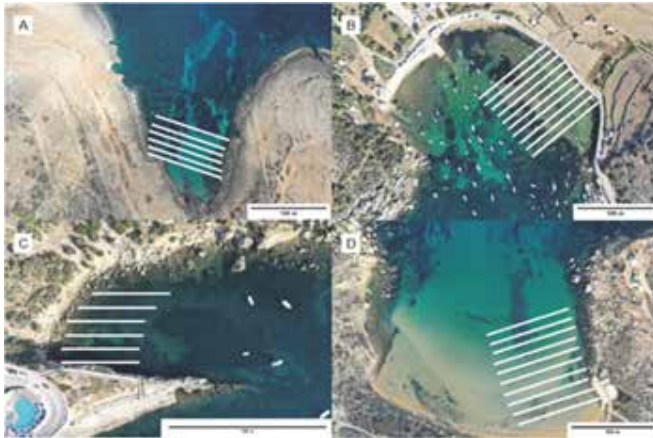

Figure 2 - Aerial images of the four sites of study (SoS), indicating the position of transects taken for the manual surveys. 100 m scale bars are at the bottom right corner of each image with North to the top of each image. A: Dahlet ix-Xmajjar (DX), B: Mistra Bay (MB), C: Dahlet il-Fekruna (DF) and D: Ghajn Tuffieha (GT).

Each SoS was also mapped using manual survey techniques (Figure 2) to enable comparison of the relative representation of BCCs between manual and drone-based methods. Data from manual surveys were obtained from transects spaced *ca.* 10 m apart, where the number of transects taken was dependent on the size of the respective SoS. Data obtained were subsequently used to show approximate benthic assemblage distributions for each SoS. The correspondence between relative representation of BCCs in PCIs and in maps from manual surveys was compared using Principal Component Analysis (PCA).

The effect of benthic heterogeneity on the relative efficiency of both methods was tested using the Shannon-Wiener diversity index (H) as a measure of benthic complexity. This first-order diversity index has found very wide application in ecological studies where it is generally used to express the alpha diversity of a community. It was considered suitable for the purpose of expressing benthic heterogeneity since the fundamental principles that govern the use of this index have not been violated by taking BCCs in place of species [6]. The ‘reference heterogeneity’ for each SoS was calculated from the PCIs and expressed as H_{SoS} . This was subsequently compared against the ‘discrepancy’ between the relative representation of BCCs in the ‘drone-based survey’ and ‘manual field survey’ for each SoS.

The discrepancies for each SoS were estimated by measuring the Euclidean distance between the two data points for each SoS (one drone-based and one manual) on the PCA plot. The discrepancies were then correlated with the heterogeneity of each SoS by calculating the Pearson product-moment correlation coefficient.

The duration and manpower required to carry out each survey was recorded for both the drone and manual surveys and quantified in man-hours. This was subsequently used to compare the relative efficiencies, in area surveyed per man-hour, of the two methods.

Results

The original aerial images and the PCIs obtained after image segmentation are shown in Figure 2 to Figure 5.

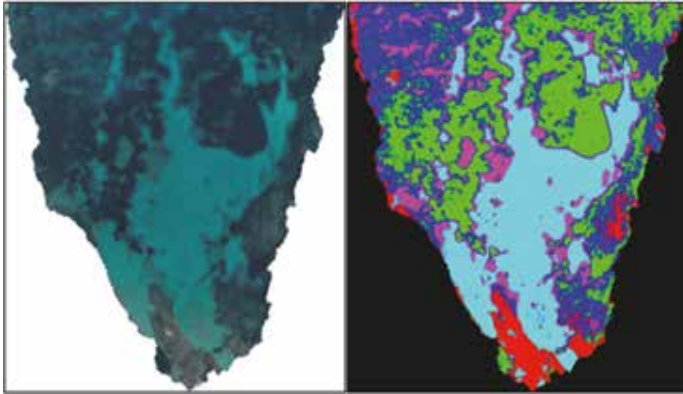

Figure 2 - Aerial image (left) and Pseudocolour image (PCI) (right) of benthic assemblages at Dahlet ix-Xmajjar (DX). PCI generated through k -means clustering ($k=7$). Two clusters corresponded to the same benthic cover class (BCC) and were merged into the Cyan BCC. BCCs: Blue=Rock with photophilic algae (RPA), Cyan=Bare sand (BS), Green=*Posidonia* meadow (PM), Magenta=Bare submerged rock (BSR) and Red=Bare exposed rock (BER).

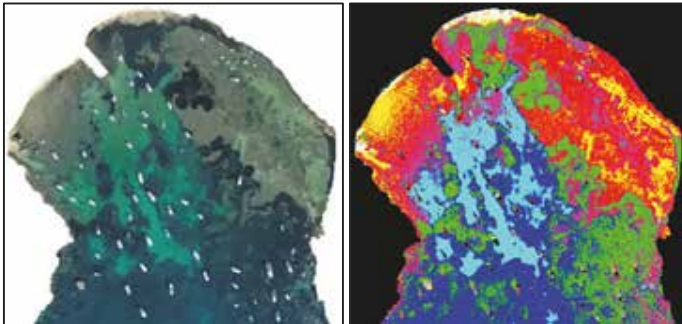

Figure 3 - Aerial image (left) and Pseudocolour image (PCI) (right) of benthic assemblages at Mistra Bay (MB). PCI generated through k -means clustering ($k=8$), where each colour corresponds to one benthic cover class (BCC). BCCs: Blue=*Posidonia* meadow (PM), Green=Juvenile *Posidonia* (JP), Magenta=Bare submerged rocks and pebbles (BSR), Red=Dead matte 'reef' (DM), Cyan=Bare sand (BS) (deep), Yellow=BS (shallow) and White=BS (exposed).

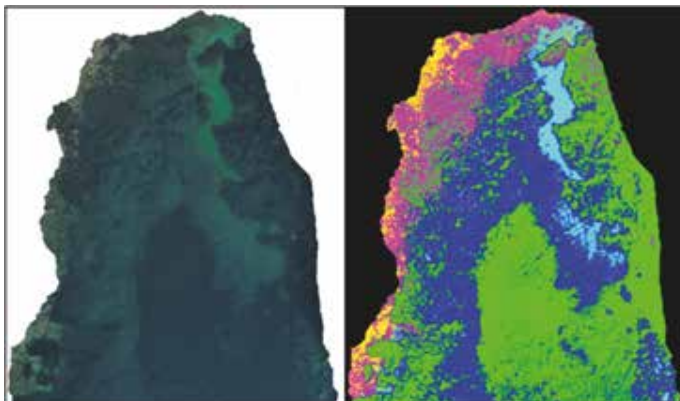

Figure 4 - Aerial image (left) and Pseudocolour image (PCI) (right) of benthic assemblages at Dahlet il-Fekruna (DF). PCI generated through k -means clustering ($k=6$), where each colour corresponds to one benthic cover class (BCC). BCCs: Blue=Juvenile *Posidonia* (JP), Cyan=Bare sand (BS), Green=*Posidonia* meadow (PM), Magenta=Rock with photophilic algae (RPA) and Yellow=Bare submerged rocks and pebbles (BSR).

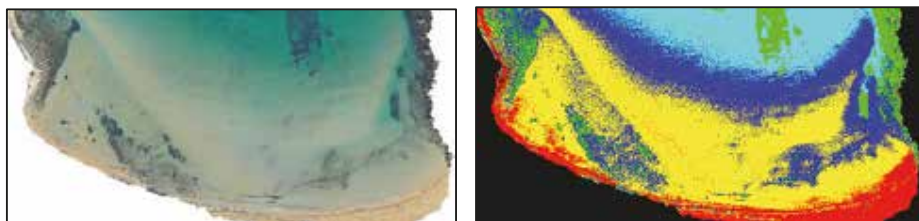

Figure 5 - Aerial image (left) and Pseudocolour image (PCI) (right) of benthic assemblages at Ghajn Tuffieha (GT). PCI generated through k -means clustering ($k=6$), where each colour corresponds to one benthic cover class (BCC). BCCs: Blue=Bare sand (BS) (with degraded *Posidonia* dust), Cyan=BS (deep), Yellow=BS (shallow), Red=BS (exposed) and Green=Rock with photophilic algae and *Posidonia* debris (RPA).

The correspondence between percentage cover of BCCs for each SoS derived from both survey methods is shown in the PCA ordination plot in Figure 6. Considerable overlap of the convex hulls in the PCA plot indicates high correspondence between the relative coverage of the BCCs for both survey methods. The relative contribution of BCCs from PCIs and Manual surveys was significantly correlated across all SoSs ($r=0.845$, $p<0.0001$).

The hypothesis that benthic heterogeneity contributed significantly to the discrepancy between the two survey methods was tested by correlating the discrepancy between the two methods for each SoS with the value of H for that SoS. There was no significant correlation between discrepancy and H_{SoS} ($r=-0.0379$, $p=0.962$), showing that

the differences between automated and manual methods were not attributable to differences in benthic heterogeneity.

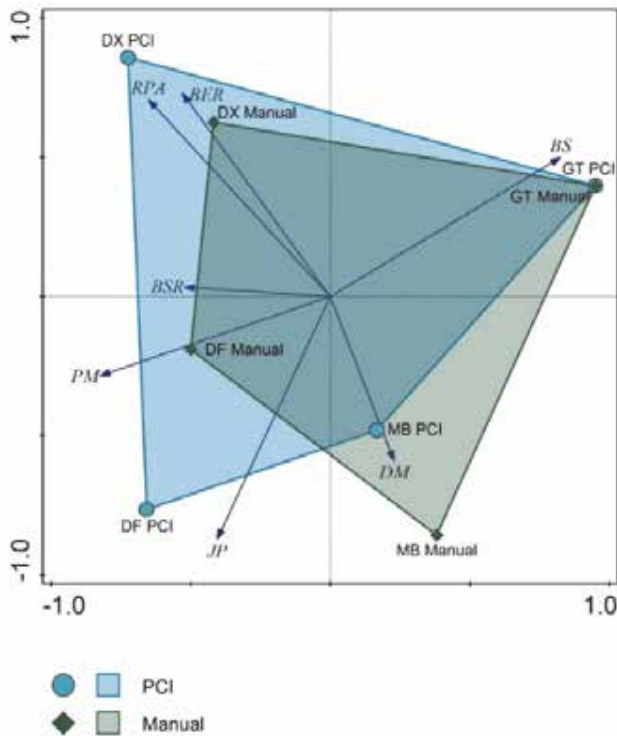

Figure 6 - Principal Component Analysis (PCA) ordination plot data of benthic cover class (BCC) percentage cover in maps produced via drone surveys (pseudocolour images; PCI) and through Manual surveys for the four sites of study (SoS): Dahlet ix-Xmajjar (DX), Mistra Bay (MB), Dahlet il-Fekruna (DF) and Ghajn Tuffieħa (GT). BCC vectors: Bare exposed rock (BER), Bare Sand (BS), Bare submerged rock (BSR), Dead matte (DM), Juvenile *Posidonia* (JP), *Posidonia* meadow (PM), and Rock with photophilic algae (RPA). The first two ordination axes explain 71.7 % of the variation within the data.

The relative efficiency of the two survey methods was assessed by comparing the area surveyed per man hour (m^2h^{-1}). Figure 7 indicates that the automated drone survey method was significantly more efficient than the direct manual survey method in all four sites. The drone survey was also more accurate than the manual survey, in that it mapped the entire area without the need for any interpolation between transects.

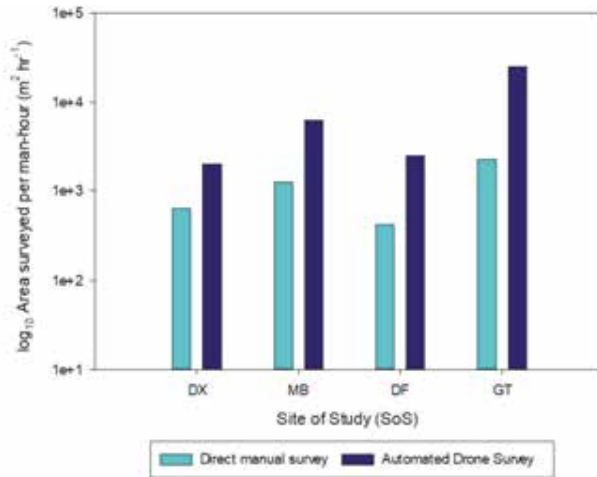

Figure 7 - Relative efficiency, expressed as Area surveyed per man-hour (m^2h^{-1}), for both survey methods at each site of study (SoS).

Discussion

The results obtained during this preliminary study clearly indicated that automated drone surveys were faster and more accurate than manual survey methods. This result has important implications for the scientific and economic aspects of the process and would have a cumulative multiplicative effect in monitoring programmes that require regular surveys.

PCIs were found to be a better approximation of the distribution of benthic assemblages when compared to maps produced via manual surveys, whereby both approaches are based on simplification of the real field situation. PCIs reduce aerial images into a small number of chromatic dimensions, while manual surveys subsample at intervals. The differences in the results returned by the two methods is attributable to the simplification process employed in manual surveys and is independent of habitat heterogeneity.

Although the duration of the automated drone survey varied depending on the size of each study site, it amounted to less than 48 hours per bay. This value is inclusive of the drone survey, image analysis to construct the PCI, BCC identification and verification via ground truthing. This greatly reduces the time taken and manpower required when compared to manual survey methods, which may take days to cover similarly-sized areas, and require significantly higher manpower. The PCIs produced through a drone-assisted survey are therefore particularly useful in the context of a regular monitoring programme, where quantification of change in benthic assemblages is required. The speed and accuracy of the drone survey would permit more frequent monitoring, increasing the probability of early detection of any environmental change.

The only real limitation with regards to using drones for mapping purposes is the weather, since the drone cannot be flown in rainy conditions, and waves caused by strong winds obscure the benthos. The time of day at which the drone is flown is also a factor due to the sun's glare on the water's surface, which also obscures the benthos beneath. In

addition, aerial imagery can only be used for mapping of benthic assemblages in very shallow waters and requires high water transparency.

Conclusion

We may therefore conclude that while manual and automated surveys give results of comparable accuracy in terms of the BCCs present, drones are able to survey larger areas and produce maps with greater precision. This is because unlike in manual surveys, automated surveys using a drone allow for the acquisition and processing of larger areas in a shorter timeframe. This saves time and allows individuals to map larger areas per unit time.

References

- [1] Bellia, A. F., & Lanfranco, S. (2019) - *A Preliminary Assessment of the Efficiency of Using Drones in Land Cover Mapping*. Xjenza, 7(1), 18-27.
- [2] Blondeau-Patissier, D., Gower, J. F., Dekker, A. G., Phinn, S. R., & Brando, V. E. (2014) - *A review of ocean color remote sensing methods and statistical techniques for the detection, mapping and analysis of phytoplankton blooms in coastal and open oceans*. Progress in oceanography, 123, 123-144.
- [3] Ng, H. P., Ong, S. H., Foong, K. W. C., Goh, P. S., & Nowinski, W. L. (2006) - *Medical image segmentation using k-means clustering and improved watershed algorithm*. In 2006 IEEE southwest symposium on image analysis and interpretation (pp. 61-65). IEEE.
- [4] Orlando-Bonaca, M., Lipej, L., & Orfanidis, S. (2008) - *Benthic macrophytes as a tool for delineating, monitoring and assessing ecological status: the case of Slovenian coastal waters*. Marine pollution bulletin, 56(4), 666-676.
- [5] Schneider, C. A., Rasband, W. S., & Eliceiri, K. W. (2012) - *NIH Image to ImageJ: 25 years of image analysis*. Nature methods, 9(7), 671-675.
- [6] Spellerberg, I. F., & Fedor, P. J. (2003) - *A tribute to Claude Shannon (1916–2001) and a plea for more rigorous use of species richness, species diversity and the ‘Shannon–Wiener’ Index*. Global ecology and biogeography, 12(3), 177-179.
- [7] Ventura, D., Bonifazi, A., Gravina, M. F., Belluscio, A., & Ardizzone, G. (2018) - *Mapping and classification of ecologically sensitive marine habitats using unmanned aerial vehicle (UAV) imagery and object-based image analysis (OBIA)*. Remote Sensing, 10 (9), 1331.

MONITORING OF POSIDONIA OCEANICA MEADOWS IN THE SICILIAN COASTS UNDER THE WATER FRAMEWORK DIRECTIVE (WFD)

Giancarlo Bellissimo, Benedetto Sirchia, Vincenzo Ruvolo
Regional Agency for the Environmental Protection (ARPA Sicilia),
Department State of the Environment and Ecosystems, Complesso monumentale Roosevelt,
Lungomare Cristoforo Colombo 4521, Loc. Addaura - 90149 Palermo (Italy)
phone +39 091 532197, e-mail: gbellissimo@arpa.sicilia.it

Abstract – The present paper aims to assess for the first time the ecological status of the Sicilian water bodies (WBs) using the PREI (*Posidonia oceanica* Rapid Easy Index) method according to the Water Framework Directive (WFD, 2000/60/EC) requirements. The PREI is based on five metrics: shoot density, shoot leaf surface area, E/L ratio (Epiphytic biomass/Leaf biomass), depth of lower limit, and type of this lower limit. Monitoring of the 29 *P. oceanica* meadows allowed to classify the 20 WBs of Sicilian coasts in the first two levels of status: 10 as “high” and 10 as “good” with the PREI values ranged between 0,551 and 1. This classification is in accordance with our field knowledge and with our knowledge of the literature.

Introduction

In the Mediterranean Sea, the endemic seagrass *Posidonia oceanica* (L.) Delile forms monospecific meadows widely distributed, from the surface up to more than 40 m deep depending upon water transparency [6], constituting an engineering ecosystem and playing a major ecological, geological and economic role in coastal water areas [7, 20].

Due to its high sensitivity to human-induced disturbances, *P. oceanica* is considered to be appropriate for biomonitoring because of its wide geographical distribution, reasonable size, sedentary habit, longevity, permanence over the seasons and easy collection [6, 13, 14, 19]. *P. oceanica* meadows are susceptible to regression in response to specific impacts, thus their presence and abundance is an indicator of the overall environmental quality of the coastal zone [11, 15]. Indeed, the monitoring of structural and functional descriptors of *P. oceanica* meadow health status [8] provides important information about the vitality and dynamic of meadows [18].

Over recent decades, *P. oceanica* is listed as a protected species under several international conventions ratified by most countries of the Mediterranean and as priority natural habitat type for conservation (1120 *Posidonia* beds) under the Habitat Directive (92/43/EEC). Also, *P. oceanica* is one of the four Biological Quality Elements (BQEs) that is regularly used in the evaluation of the Ecological Status (ES) of any given coastal Water Body (WB) in accordance with the Water Framework Directive (WFD, 2000/60/EC) requirements. Phytoplankton, macroalgae and benthic fauna are the other BQEs to be considered. Recently, *P. oceanica* has been selected as an indicator of the Good Environmental Status for marine areas within the Marine Strategy Framework Directive (MSFD, 2008/56/EC).

In Sicily, *P. oceanica* is the most common seagrass covering about 76 000 ha of coastal areas, with dense and extensive meadows mainly distributed along the western and south-eastern coasts [10].

As required by the Italian national law (Ministerial Decree n. 260/2010), the PREI index (*Posidonia oceanica* Rapid Easy Index) is being regularly applying in Italy as a monitoring tool for the Regional Agencies to assess the environmental quality of marine and coastal water bodies [11]. The first application of this index was carried out by ARPA Sicilia in 2013 exclusively in the south coast of Sicily within the framework of “Caulerpa Project” funded by the Mediterranean Fisheries Department of the Sicily Region [3]. Nevertheless, no PREI monitoring data are available in literature with the requirements of the WFD along the totality of the Sicilian coasts. Here we present a first assessment of the environmental quality of marine and coastal waters along the Sicilian coastline using the PREI method in the framework of the institutional monitoring program of the Sicily Region (Water and Waste Department - “DAR Project”) for the implementation of the Italian national law (Legislative Decree 152/06).

Materials and Methods

In the context of a regional agreement (Management Plan of the Hydrographic District of Sicily of 2010) between the Regional Agency for the Environmental Protection of Sicily (ARPA Sicilia) and the Water and Waste Department of the Sicily Region, the Sicilian coastline was divided into 65 WBs identified by ARPA and Sicily Region [2]. In 2016, an update of the Management Plan was performed with the aim of identifying 30 WBs homogeneously distributed along the entire Sicilian coast [4]. Monitoring was carried out in spring-summer 2018 in 20 out of the 30 WBs identified along the entire coastline of the Sicily Region. Indeed, 10 WBs were characterized by the lack of *P. oceanica* meadows and thus they were not considered in the monitoring program (Fig. 1).

However, on the basis of the above-mentioned agreement that planned the overall monitoring of 29 *P. oceanica* meadows, further 9 meadows were chosen and monitored within the 20 WBs (Fig. 1). In particular, two more meadows were selected within the WB 17 and one more within seven water bodies (WB 1-2-3-19-23-28-30). Four *P. oceanica* meadows settled exclusively on sandy bottom (WB 5-9-11-30) while the remaining twenty-five meadows on both sandy bottom and *matte*. Also, 20 out of the 29 *P. oceanica* meadows were located in the sites of the Natura 2000 Network.

The PREI was used with metrics selected according to the requirements of the WFD: shoot density, shoot leaf surface area, *E/L* ratio (ratio between epiphytic biomass and leave biomass) measured on shoots sampled at the same depth, depth of lower limit and type of this limit (progressive, clear-cut, erosive or regressive). These metrics were selected because they provide pertinent information on the vitality of the meadow (at the individual and population level) for a wide spectrum of disturbance (water transparency, nutrient concentrations and eutrophication, sedimentary dynamics, grazing pressure) regularly described in the Mediterranean Sea [17].

The classification of ecological status is based on the deviation of the status of the BQE from its potential status under pristine conditions (reference conditions: RC). The PREI values range from 0 (worst conditions where the BQE is badly affected or missing) to 1 (RC) corresponding to Ecological Quality Ratio (EQR) boundaries reported in the WFD.

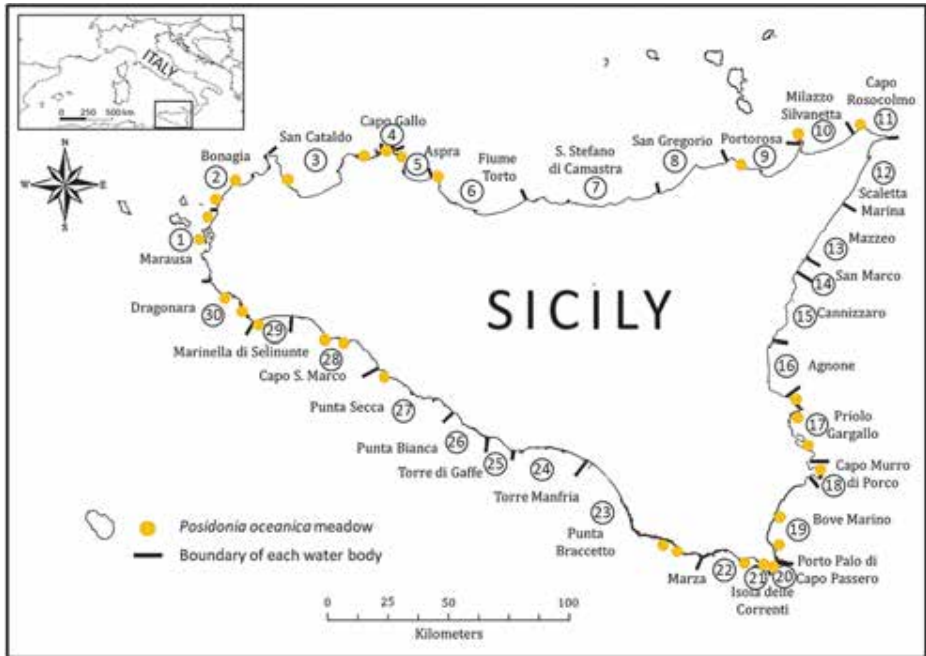

Figure 1 - Location of *Posidonia oceanica* meadows distributed along the Sicilian coastline within 20 water bodies (1-30).

A hierarchical sampling design was used to investigate structural and biological characteristics of the 29 meadows along Sicilian coasts. Sampling procedures as well as laboratory analyses (phenology, lepidochronology and biomass) were carried out following ISPRA (Italian National Institute for Environment Protection and Research) methodological report indications [5].

In each meadow, two sampling stations were investigated by scuba divers: one at the fixed depth of 15 m (A) and one in correspondence of the lower limit (B). At each station (A), three areas of 400 m² were selected at the distance of tens of meters each other within which 3 replicates measures of shoot density (40 cm x 40 cm) were carried out and 6 orthotropic (vertically oriented) shoots as well as a sediment sample were collected.

Likewise, at each station (B) along a horizontal transect, the same number of replicates measures of shoot density (3) and samples (6) was considered. In addition, in both stations estimates of some descriptors (flowering, bottom type, meadow continuity and cover, % dead *matte*, % invasive algae) were carried out, while measures of depth, lower limit type and rhizome baring were also recorded exclusively at each station B.

In both stations, *P. oceanica* shoots were sampled only in meadows settling on sandy bottom or *matte*, excluding rocky bottom as in accordance with [5].

In this study, only the results of the PREI metrics have been reported whereas all the other together with leaf biometry and primary production are available in the ARPA Sicilia monitoring report [4].

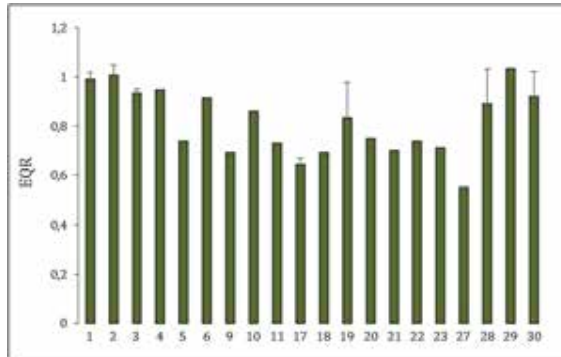

Figure 3 - EQR values for each of the 20 water bodies monitored along the Sicilian coastline (1-30). Error bars: standard deviation.

Discussion

The ES of the Sicilian coastline reflected a good environmental quality. In fact, all the 20 Sicilian water bodies considered in the present study reached the “good” ES that represents the WFD’s goal by 2021 in the second cycle of monitoring. Such results are in line with a positive trend of the ecological quality based on *P. oceanica* that has always been maintained along the Sicilian coasts for over a decade [1, 3, 10]. Low anthropogenic pressure, sedimentation rate and favourable temperature are some factors likely to explain the good health status of the Sicilian meadows [10].

Among the PREI metrics, *P. oceanica* density is considered an important structural descriptor for assessing the state of the vitality of a meadow and provides information on the changes to which the meadows are subject when measured on a pluriennial time scale [15,19]. According to the standardized scale for density classification [16], all the *P. oceanica* meadows appeared to be in “equilibrium” at the depths where sampling was done, except for two meadows in the WB 17, probably affected by industrial activities of the petrochemical complex of Augusta-Priolo. In this area, signs of evident regression up to complete disappearance have been already detected in the past [10].

Based on the literature data, the highest values of density were recorded along the western and south-eastern Sicilian coasts [10]. Our results showed a similar finding only in the western coast while, on the contrary, no significant values were recorded in the south-eastern one. In addition to the density, the western sector of the Sicilian coastline showed the highest values of shoot leaf surface area and leaf biomass as in accordance with previous studies [1,10], providing evidence of the good condition of Sicilian meadows.

The typology of the lower depth limit of *P. oceanica* meadows is considered an important descriptor to evaluate extension/regression balancing conditions of the meadows, allowing to detect the principal local factors controlling the bathymetric distribution of the plant along Sicilian coasts [19]. The high frequency of the progressive limit typology found along the Sicily coasts reflected the high water transparency with the exception of the southern coasts where morphology and composition of the bottom reduce water

transparency. In particular, in some areas the increased turbidity seemed to be the main factor limiting the meadow's progression. The epiphyte biomass of *P. oceanica* plays an important role in marine ecosystems contributing significantly to the primary production of the meadow [12] and is considered a useful biological indicator of environmental changes with evidences of positive relationships of epiphyte load to nutrients concentration [16]. The presence of untreated wastewater sewages close to the municipality of Palermo (WB 5) and the industrial area of Augusta (WB 17) are likely to justify the highest values of epiphyte biomass detected in some meadows.

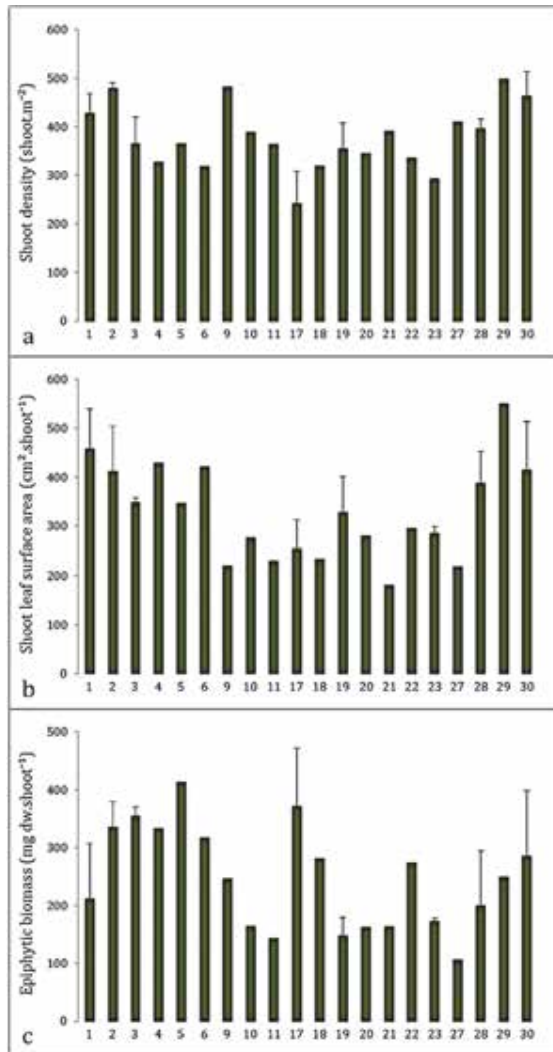

(Figure 4 continued on next page)

(Figure 4 continued from the previous page)

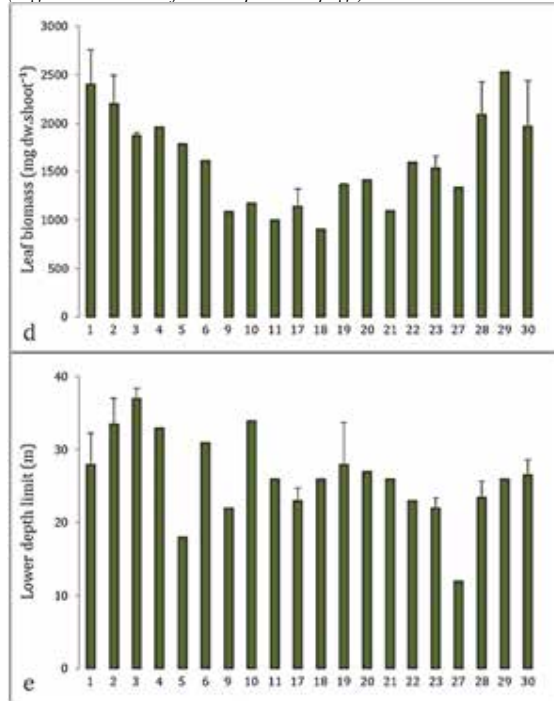

Figure 4 - a-e. PREI metrics values (a. shoot density, b. shoot leaf surface area, c. epiphytic biomass, d. leaf biomass, e. lower depth limit) for each of the 20 water bodies (1-30) monitored along the Sicilian coastline. Error bars: standard deviation.

Conclusion

The outcomes of the present study represent the first data available in the evaluation of the ecological quality of Sicilian coastal waters based on PREI index and are critical as a first baseline to ensure that habitat changes are monitored and managed appropriately. Further long-term observations are needed and more information on other possible sources of impact should be gathered to obtain more reliable conclusions.

Acknowledgments

We wish to acknowledge all colleagues of the Department State of the Environment and Ecosystems (“Area Mare”) for sampling support. The present work is a contribution to “Monitoring plan of the Sicilian marine and coastal waters” for the implementation of the Italian Legislative Decree (152/06)” in the framework of the “DAR” project funded by the Water and Waste Department of the Sicily Region.

References

- [1] AA.VV. (2007) - *Studi applicativi finalizzati all'attivazione del sistema di monitoraggio delle acque marino costiere della Regione Sicilia*, ARPA Sicilia & UNIPA, Technical Report, February 2007, pp. 1 - 245.
- [2] AA.VV. (2008) - *Rapporto sulle attività relative al monitoraggio delle comunità fitobentoniche ai sensi del D. Lgs. 152/2006*, ARPA Sicilia, Technical Report, November 2008, pp. 1 - 55.
- [3] AA.VV. (2014) - *Progetto Caulerpa (Indagini ambientali e rilievi sulla diffusione della Caulerpa nel Canale di Sicilia)*, ARPA Sicilia, Technical Report, November 2014, pp. 1 - 80.
- [4] AA.VV. (2018) - *Convenzione per l'aggiornamento del quadro conoscitivo sullo stato di qualità delle acque sotterranee, superficiali, interne, superficiali, marino-costiere ai fini della revisione del piano di gestione del distretto idrografico della Regione Sicilia*, ARPA Sicilia, Technical Report, December 2018, pp. 1 - 630.
- [5] Bacci T., Rende F., Montefalcone M. (2012) - *Quaderno metodologico sull'elemento biologico ANGIOSPERME e sul calcolo dello stato ecologico secondo la metodologia PREI*. In: ISPRA - Istituto Superiore per la Protezione e la Ricerca Ambientale, Roma, February 2012, p. 14.
- [6] Boudouresque C.F., Charbonnel E., Meinesz A., Pergent G., Pergent-Martini C., Cadiou G., Bertrand M.C., Foret P., Ragazzi M., Rico-Raimondino V. (2000) - *A monitoring network based on the seagrass Posidonia oceanica in the northwestern Mediterranean Sea*, Biol. Mar. Medit. 7 (2), 328 - 331.
- [7] Boudouresque C.F., Bernard G., Bonhomme P., Charbonnel E., Diviacco G., Meinesz A., Pergent G., Pergent-Martini C., Ruitton S., Tunesi L. (2012) - *Protection and conservation of Posidonia oceanica meadows*, RAMOGE, RAC/SPA and GIS Posidonie publications, Marseilles, 202 pp.
- [8] Buia M.C., Gambi M.C., Dappiano M. (2003) - *I sistemi a fanerogame marine*. In: Gambi M.C., Dappiano M. (Editors). *Manuale di Metodologie di campionamento e studio del benthos marino mediterraneo*, Biol. Mar. Medit. 19 (Suppl.), 145 - 198.
- [9] Calvo S., Fradà Orestano C., Tomasello A. (1995) - *Distribution, structure and phenology of Posidonia oceanica meadows along sicilian coasts*, G. Bot. Ital. 129 (1), 351 - 356.
- [10] Calvo S., Tomasello A., Di Maida G., Pirrotta M., Buia M.C., Cinelli F., Cormaci M., Furnari G., Giaccone G., Luzzu F., Mazzola A., Orestano C., Procaccini G., Sarà G., Scannavino A., Vizzini S. (2010) - *Seagrasses along the Sicilian coasts*, Chem. Ecol. 26 (1), 249 - 266.
- [11] Gobert S., Sartoretto S., Rico-Raimondin V., Andral B., Chery A., Lejeune P., Boissery P. (2009) - *Assessment of the ecological status of Mediterranean French coastal waters as required by the Water Framework Directive using the Posidonia oceanica Rapid Easy Index: PREI*, Mar. Pollut. Bull. 58, 1727 - 1733.
- [12] Lepoint G., Havelange S., Gobert S., Bouquegneau J.M. (1999) - *Fauna vs. flora contribution to the leaf epiphytes biomass in a Posidonia oceanica seagrass bed (Revellata Bay, Corsica)*, Hydrobiologia 394, 63 - 67.
- [13] Marbà N., Díaz-Almela E., Duarte C.M. (2014) - *Mediterranean seagrass (Posidonia oceanica) loss between 1842 and 2009*, Biol. Conserv. 176, 183 - 190.

- [14] Martínez-Crego B., Vergés A., Alcoverro T., Romero J. (2008) - *Selection of multiple seagrass indicators for environmental biomonitoring*, Mar. Ecol. Prog. Ser. 361, 93 -109.
- [15] Montefalcone M. (2009) - *Ecosystem health assessment using the seagrass Posidonia oceanica: a review*, Ecol. Indic. 9, 595 - 604.
- [16] Nelson W.G. (2017) - *Development of an epiphyte indicator of nutrient enrichment: a critical evaluation of observational and experimental studies*, Ecol. Indic. 79, 207 - 227.
- [17] Pergent G., Pergent-Marini C., Boudouresque C.F. (1995) - *Utilisation de l'herbier a Posidonia oceanica comme indicateur biologique de la qualité du milieu littoral en Méditerranée: état des connaissances*, Mésogée 54, 3 - 27.
- [18] Pergent G., Rico-Raimondino V., Pergent-Martini C. (1997) - *Fate of primary production in Posidonia oceanica meadows of the Mediterranean*, Aquat. Bot. 59, 307 - 321.
- [19] Pergent-Martini C., Leoni V., Pasqualini V., Ardizzone G.D., Balestri E., Bedini R., Belluscio A., Belsher T., Borg J., Boudouresque C.F., Boumaza S., Bouquegneau J.M., Buia M.C., Calvo S., Cebrian J., Charbonnel E., Cinelli F., Cossu A., Di Maida G., Dural B., Francour P., Gobert S., Lepoint G., Meinesz A., Molenaar H., Mansour H.M., Panayotidis P., Peirano A., Pergent G., Piazzzi L., Pirrotta M., Relini G., Romero J., Sanchez-Lizaso J.L., Semroud R., Shembri P., Shili A., Tomasello A., Velimirov B. (2005) - *Descriptors of Posidonia oceanica meadows: use and application*, Ecol. Indic. 5, 213 - 230.
- [20] Vassallo P., Paoli C., Rovere A., Montefalcone M., Morri C., Bianchi C.N. (2013) - *The value of the seagrass Posidonia oceanica: a natural capital assessment*, Mar. Pollut. Bull. 75, 157 - 167.

ASSESSMENT OF THE ECOLOGICAL STATUS OF SICILIAN COASTAL WATERS ACCORDING TO A MACROALGAE BASED INDEX (CARLIT)

Giancarlo Bellissimo, Benedetto Sirchia, Vincenzo Ruvolo
Regional Agency for the Environmental Protection (ARPA Sicilia),
Department State of the Environment and Ecosystems, Complesso monumentale Roosevelt,
Lungomare Cristoforo Colombo 4521, Loc. Addaura - 90149 Palermo (Italy),
phone +39 091 532197, e-mail: gbellissimo@arpa.sicilia.it

Abstract – Macroalgal communities is one of the four key Biological Quality Elements (BQEs) proposed in the Water Framework Directive (WFD, 2000/60/EC) to be used for the assessment of the Ecological Status (ES) of coastal waters bodies. Here we report the application of a macroalgae based index (CARtography of LITtoral and upper-sublittoral rocky-shore communities) along the Sicilian coastline in order to obtain a first assessment of its ecological status and collect accurate information on the distribution and abundance of shallow-water communities, especially of those most sensitive (e.g. *Cystoseira* belts).

Overall, the EQR-CARLIT values showed “high”/“good” levels in all water bodies with lushy forests of *Cystoseira amentacea* var. *stricta* except two with “moderate” level due to the presence of stress-tolerant species related to local factors. The present paper represents a baseline for monitoring long-term changes related to antropogenic disturbances and gives useful tools for the management of human impacts on the Sicilian coasts.

Introduction

In the context of the European Water Framework Directive (WFD, 2000/60/EC), the Ecological Status (ES) of coastal waters has to be quantified through indices based on appropriate Biological Quality Elements (BQEs) as bio-indicators. The assessment of water quality is based on the extent of deviation from Reference Condition (RC). A ratio between the values of the BQE observed in the sector of shore that is being assessed and the reference ones (Ecological Quality Ratio, EQR) of the indicator with no or low pressures from human activities allows to rank a given body of surface water from 0 (bad ecological quality) to 1 (high ecological quality) identifying five different ES classes: bad, poor, moderate, good and high. Intertidal macroalgal communities associated with rocky littoral habitats are known to respond significantly to different sensivity levels of environmental conditions [4, 5, 15], thus they have been proposed as a BQE for the assessment of the ES of coastal water bodies (WBs) in the Mediterranean Sea for the implementation of the WFD. Phytoplankton, angiosperms and benthic fauna are the other BQEs to be considered.

As required by the Italian national law (Ministerial Decree n. 260/2010), the CARLIT index (CARtography of LITtoral and upper-sublittoral rocky-shore communities) is the WFD-compliant monitoring method being regularly applying in Italy as a tool for the Regional Agencies to assess the environmental quality of marine and coastal waters [8]. According to this methodology, the communities are visually assessed and ranked

according to their sensitivity to perturbation: *Cystoseira amentacea* assemblages, as well as almost all other surface *Cystoseira* species, that are particularly sensitive to water quality and other disturbances [5, 8, 9], are associated to the highest values of ES. *Cystoseira compressa*, which is able to thrive in slight polluted waters [8], is associated to a lower value of ES. In contrast, stress-resistant species (e.g. articulated Corallinales and Dictyotales), that are ubiquitous and tolerant, are associated to medium values. The lowest ES values are associated to very low structured communities dominated by opportunistic species such as green algae (e.g. *Ulva* spp. and *Cladophora* spp.) and cyanobacteria [5, 19]. In addition, the distribution of the littoral and sub-littoral communities is affected not only by water quality but also by the natural geomorphological variability of the coastal environment [7].

At present, CARLIT index is widely used all around the Mediterranean Sea [6 and references therein] since: (i) it is a fast, non-destructive and simple method; (ii) it potentially takes into consideration the entire rocky coastline of an area; (iii) it does not require further analyses in the laboratory reducing the total cost of monitoring; (iv) it is based on widely distributed communities that are relatively easy to identify and whose response to anthropogenic pressures is well-known [8, 19].

In Sicily, the first attempt of the application of the CARLIT method was performed in 2008 by the Regional Agency for the Environmental Protection of Sicily (ARPA Sicilia) as part of the institutional monitoring programme (Monitoring plan of the Sicilian marine and coastal waters under the Italian Legislative Decree 152/06) [1]. However, since the network of reference sites for Italy was lacking at that time, only a first environmental quality assessment of any stretch of coastline was provided. Conversely, a monitoring through the CARLIT index was carried out by ARPA Sicilia in 2013 exclusively in the south coast of Sicily within the “Caulerpa project” funded by the Mediterranean Fisheries Department of the Sicily Region [2]. Nevertheless, no CARLIT monitoring data are available in literature with the requirements of the WFD along the totality of the Sicilian rocky coasts. For this purpose, the present work aims to apply the CARLIT index under the institutional monitoring program of the Sicily Region (Water and Waste Department - “DAR project”) for the implementation of the Italian national law (L.D. 152/06) in order to obtain for the first time an evaluation of the ES of the Sicilian coastal waters.

Materials and Methods

The island of Sicily is located in the south of Italy and encompasses more than 1150 km of coast (1600 km including the small islands).

In 2010, according to the Management Plan of the Hydrographic District of Sicily, the coast was divided into 65 WBs identified by ARPA and Sicily Region mainly taking into account the following factors: natural geomorphological features (morphology of the coast, including the adjacent mainland area and type of substrate) and hydrologic features (vertical stability of the water column), as proposes the Annex II of the WFD and Ministerial Decree n. 131/2008 [1]. In 2016, an update of the above-mentioned Management Plan was performed with the aim of identifying 30 WBs homogeneously distributed along the entire Sicilian coast [3]. In the context of the L.D. 152/2006, 19 WBs were subjected to the surveillance monitoring and the remaining 11 WBs to the operative one (Table 1). From a geomorphological point of view, the 30 WBs were divided taking into consideration five

coastal typologies [11]: 9 water bodies (WB 2-4-6-10-12-15-25-27-28) were classified as A3 (Mountain coast), 9 water bodies (WB 3-5-7-11-14-17-18-26-30) as B3 (Terrace coast), 1 water body (WB 13) as C3 (Littoral plain), 8 water bodies (WB 1-8-9-16-19-21-22-24) as E3 (River plain) and 3 water bodies (WB 20-23-29) as F3 (Dune plain) (Table 1). The CARLIT index was performed during April-June 2017, when macroalgae reach their growth peak, at 24 out of the 30 WBs. Six water bodies (WB 8-9-11-12-14-29) were completely devoid of rocky shores and thus they were not considered in the monitoring program (Fig. 1). Sandy beaches and highly modified areas such as harbors and marinas were excluded, according to [8]. CARLIT monitoring involved 244 km of rocky coast representing about 70 % of the potentially investigable rocky coastline of the Sicily (350 km at a scale 1:5000). The CARLIT method was implemented both along the totality of the rocky coast or in representative stretches of coasts long at least 3 km in 18 water bodies (WB 3-4-6-7-10-13-15-16-17-18-19-20-22-23-25-26-28-30) and in stretches of rocky coast long less than 3 km in the remaining 6 water bodies (WB 1-2-5-21-24-27). Each WB was divided into a variable number of areas (1 to 13) and sites (1 to 14) composed by 1 to 20 sectors (50 m each), depending on the length of the rocky shore and the presence of anthropized areas (ports and marinas) [1]. These WBs were selected in order to be representative of the entire Sicilian coastline (Fig. 1): 11 are located in the northern (WB 1 to 11), 9 in the eastern (WB 12 to 20) and 10 in the southern side (WB 21 to 30). Additionally, sites are differently affected by anthropogenic pressures, since they are located in harbor areas (WB 5-6-16) or within the NATURA 2000 network (WB 2-4-10-15-16-18-19-20-21-23-28). All the other sites are not subject to particular protection restrictions.



Figure 1 - Geographical distribution of the stretches of rocky coast monitored within the 24 water bodies (1-30) along the Sicilian coast.

Table 1 - Coastal typology and type of monitoring for each water body (WB).

WB	Typology	Monitoring	
1	E3	River plain	Surveillance
2	A3	Mountain coast	Surveillance
3	B3	Terrace coast	Operative
4	A3	Mountain coast	Surveillance
5	B3	Terrace coast	Surveillance
6	A3	Mountain coast	Surveillance
7	B3	Terrace coast	Surveillance
8	E3	River plain	Surveillance
9	E3	River plain	Surveillance
10	A3	Mountain coast	Operative
11	B3	Terrace coast	Surveillance
12	A3	Mountain coast	Surveillance
13	C3	Littoral plain	Surveillance
14	B3	Terrace coast	Surveillance
15	A3	Mountain coast	Surveillance
16	E3	River plain	Surveillance
17	B3	Terrace coast	Operative
18	B3	Terrace coast	Operative
19	E3	River plain	Surveillance
20	F3	Dune plain	Operative
21	E3	River plain	Surveillance
22	E3	River plain	Operative
23	F3	Dune plain	Operative
24	E3	River plain	Operative
25	A3	Mountain coast	Operative
26	B3	Terrace coast	Operative
27	A3	Mountain coast	Operative
28	A3	Mountain coast	Surveillance
29	F3	Dune plain	Surveillance
30	B3	Terrace coast	Surveillance

The sampling survey was performed with a different boat (kayak or inflatable boat) depending to the coast typology, moving at low speed and proceeding as close as possible to the shoreline, in order to record both the upper-infralittoral algal communities and the geomorphological features. When hardly accessible by boat, some sectors were sampled by snorkeling or walking.

In each sector, the main community categories (defined in Table 2) and geomorphological features were visually recorded and noted directly on a cartographic support using the Quantum Geographical Information System (QGIS).

During the sampling procedure no endangered or protected species has been collected or damaged. Each WB was sampled in one day; the same team of experts, applying the identical methodology, was involved along the considered time-frame (the whole spring season), in order to overcome the possible bias related to operator subjectivity that can potentially confound the attribution of the correct community category, affecting the CARLIT Index calculation.

The Ecological Quality value of any sector of coast was calculated as EQV = $\Sigma(l_i * SL_i) / \Sigma l_i$ where l_i represents the length of the coastline occupied by the community category i and SL_i the sensitivity level of the community category i (Table 2). The EQR

value was obtained, in each sector, comparing the EQV to the corresponding values calculated at reference sites, according to the six different geomorphological relevant conditions described by [8]. EQR values range from 0 to 1, but values higher than 1 may be found when the EQV of the considered sector is higher than the EQV of the reference sites. The rating scale of EQR values was defined by [8]: 0–0.25 (bad), >0.25–0.40 (poor), >0.40–0.60 (moderate), >0.60–0.75 (good) and >0.75–1 (high).

Table 2 - Summarized description and sensitivity levels (SL, from 20 to 1) of the main community categories as reported in the methodological contribution published by ISPRA (modified from [18]).

Community category	Description	SL	Comm. Acronym
Trottoir ^a	Large organogenic build-ups of <i>Lithophyllum hispidoides</i> , <i>Lithophyllum trochanter</i> , <i>Dendropoma^b</i>	20	TR
<i>Cystoseira brachycarpa / crinita / algaus</i>	Community dominated by <i>Cystoseira brachycarpa / crinita / elegans</i>	20	CB
<i>Cystoseira sheltered</i>	Community dominated by <i>Cystoseira feniculata / barbata / humilis / spinosa</i>	20	Cs
<i>Cystoseira amenataca / mediterranea</i>	Continuous belt of <i>Cystoseira amenataca / mediterranea</i>	20	CA5
<i>Cystoseira amenataca / mediterranea</i>	Almost continuous belt of <i>Cystoseira amenataca / mediterranea</i>	19	CA4
<i>Cystoseira amenataca / mediterranea</i>	Abundant patches of dense stands of <i>Cystoseira amenataca / mediterranea</i>	15	CA3
<i>Cystoseira amenataca / mediterranea</i>	Abundant scattered plants of <i>Cystoseira amenataca / mediterranea</i>	12	CA2
<i>Cystoseira compressa</i>	Community dominated by <i>Cystoseira compressa</i>	12	CC
<i>Cystoseira amenataca / mediterranea</i>	Rare scattered plants of <i>Cystoseira amenataca / mediterranea</i>	10	CA1
Diptycales / Sypocaulaceae	Community dominated by <i>Padina / Diptyxis / Diptyxis / Taonia / Sypocaulon</i>	10	DS
Corallina	Community dominated by <i>Corallina</i> spp. (including <i>Ellislandia elongata</i>)	8	Cor
Encrusting corallinales	Community dominated by <i>Lithophyllum incrustans</i> , <i>Neogoniolithon brassica-floida</i> and other encrusting corallines	6	EC
Mussels	Community dominated by <i>Mytilus galloprovincialis</i>	6	Mgal
<i>Pterocladella / Ulva / Schizymenia</i>	Community dominated by <i>Pterocladella / Ulva / Schizymenia</i>	6	Ulv
Green algae	Community dominated by <i>Ulva</i> and / or <i>Cladophora</i>	3	GA
Blue greens	Community dominated by <i>Cyanobacteria</i> and <i>Derbesia tenuissima</i>	1	BG
<i>Posidonia</i> reef	Barrier and fringing reefs of <i>Posidonia oceanica</i>	20	Pos
<i>Cymodocea nodosa</i>	Superficial <i>Cymodocea nodosa</i> meadows	20	Cym
<i>Zostera noltii</i>	Superficial <i>Zostera noltii</i> meadows	20	Zos

^aExcept for the category Trottoir, which is generally found in the mediotlitoral zone, all the other categories only have been taken into account when present in the infralittoral fringe zone.

^b*Dendropoma* forms organogenic build-ups typical of Sicily and other South Italian regions.

In the case of rare scattered plants of *Cystoseira amenataca / mediterranea*, the dominant community also has to be noted down. (Sensitivity level—SL: average value). In case of sectors equally dominated by two different community categories, the average value between the two is taken into account (e.g. Cor+Mgal:SL = 7)

Results

According to the results reported in Fig. 2, the ES of the Sicilian rocky shores showed overall quite positive evidences: 18 out of the 24 WBs were classified as “high” and 4 out of the 24 WBs as “good” with EQR-CARLIT values ranging from 0,72 to 1,35 (Fig. 3). On the contrary, the two remaining water bodies (WB 16 and 24) were classified as “moderate” with EQR-CARLIT values of 0,54 and 0,43, respectively (Fig. 2 and 3). In the present study, the two lowest ecological status classes, “poor” and “bad”, have never been recorded along the Sicilian coast.

Cystoseira amentacea was the dominant community of the shallow rocky coasts of Sicily, homogeneously distributed in the different categories, from scattered plants to continuous belts (CA1-CA5). In particular, dense stands of *C. amentacea* were observed often associated with large vermetid reefs of *Dendropoma* (TR) in the north-western coast (WBs 1 to 6) or with small reefs, shaped as ledges and encrustations of *Lithophyllum byssoides* (TR) in the eastern coast (WB 13 and 18). Barrier and fringing reef of *Posidonia oceanica* (Pos) were observed along stretches of coast of four water bodies (WB 1-23-26-28). In the eastern side of Sicily (WB 15 and 16), a community dominated by *Corallina* spp. (Cor) and green algae (GA) was observed along most of rocky coast.

In the south-east side (WBs 20 to 25), the community was generally dominated by *Cystoseira compressa* (CC) that formed a mixed community with *C. amentacea* in four water bodies (WB 20-21-25-26) or with GA in other two water bodies (WB 22 and 24). Other less sensitive photophilic algae, such as species belonging to the orders Dictyotales and Sphacelariales (DS) or to the *Laurencia complex group* represented the dominant community in some stretches of coast (WB 6-20-21).

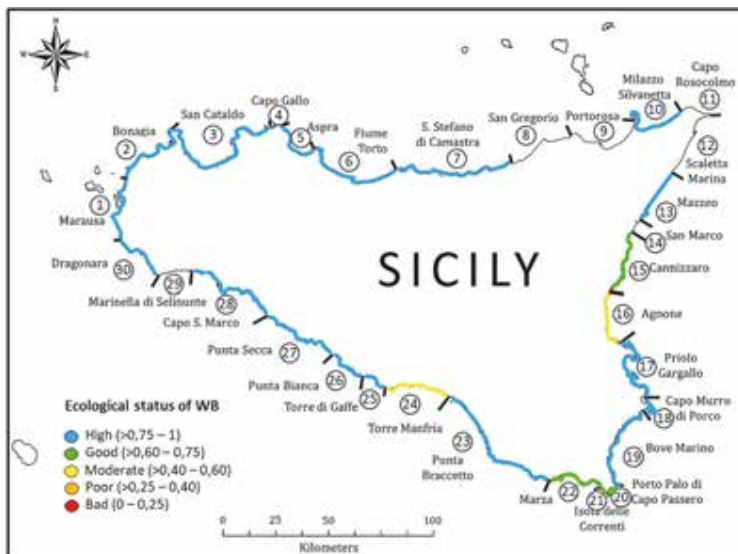

Figure 2 - Cartographical representation of the ES of the 24 WBs (1-30) monitored in the Sicilian coast through the CARLIT Index.

Discussion

The main goal of the WFD is to achieve and maintain a “good” ES of all the European waters by 2015 in its first management cycle. All the 24 Sicilian water bodies considered in the present study (with only two exceptions) reached the “good” ES that represents the WFD’s goal by 2021 in the second management cycle. Such a result is in agreement with a general improvement of the ecological quality, based on CARLIT index, observed recently at a larger scale in the North-Western Mediterranean basin [10, 14]. Moreover, this study highlights a remarkable positive trend that has always been maintained for over a decade since a first ecological quality assessment of the intertidal macroalgal assemblages has been carried out along the Sicilian coastline [1]. In addition, a recent application of the CARLIT protocol along the southern coast of Sicily revealed a “good” ES of coastal waters pointing out the lack of significant changes in ES related to anthropogenic impacts along a decade [2].

“High” class of the ES was related to the presence of *Cystoseira amentacea* and vermetid reefs, the latter commonly referred to by the French name of *trottoir*, that both act as biological engineers creating complex habitats on the narrow Mediterranean intertidal fringe and are essential for biodiversity and ecosystem functioning [12, 13].

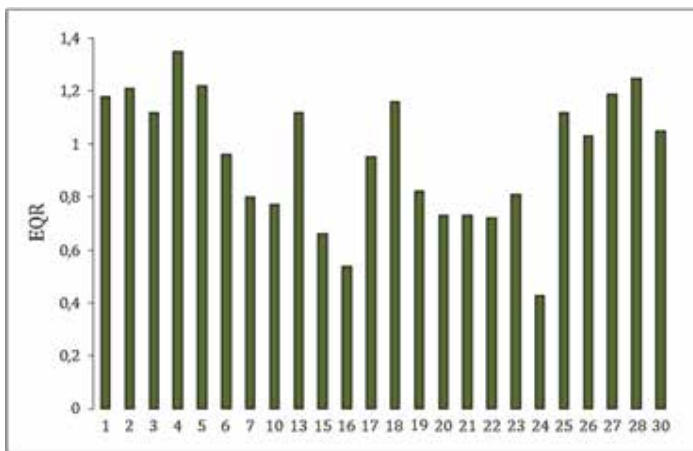

Figure 3 - CARLIT EQR values of the 24 water bodies (1 - 30) monitored along the Sicilian coastline.

C. amentacea is completely missing in some stretches of coast free of human-induced impacts in the south side of the Sicilian coastline in favour of photophilic intermediate sensitive communities (*i.e.* DS and Cor). Despite the absence of the species with the highest sensitivity level (*C. amentacea*), ES values belonging to the “good” class have been recorded also in this area within some water bodies. This outcome matched with the findings of a recent study according to which, in absence of anthropogenic pressures, the distribution of *C. amentacea* of the infralittoral fringe can be induced by the morphology of the coast,

mainly related to the coastline slope [16]. Urbanization, including artificialization of the coastline and sewage, are known to affect the very shallow communities, together with industrial impacts, as observed in many Mediterranean areas [5, 6, 19]. Agricultural discharges and illegal domestic/urban outfalls are most likely responsible of a moderate to poor ES in some sectors of the Sicilian coastline (WB 5, 15, 16, 17, 22, 23, 24). However, only two water bodies (WB 16 and 24) did not yet fulfill the WFD requirements being classified as “moderate”. In Agnone (WB 16), urbanization impact related to the Catania urban center and freshwater input from the Simeto river, are the major pressures typologies, mirrored by the presence of communities categories with low sensitivity levels (*i.e.* Ulva and Mgal). Similarly, Torre Manfreda (WB 24) was characterized by freshwater inputs from several waterways that favoured the development of a community dominated by tionitrophilous species (*i.e.* *Ulva* spp.).

Conclusion

The implementation of CARLIT in the areas surveyed so far has provided valuable data on the ES of the water bodies, but also on the present distribution and abundance of shallow water assemblages dominated by *Cystoseira* spp.

Cystoseira forests are common in almost all Sicilian rocky coasts and the understanding of mechanisms that affect their distribution is a relevant issue in the framework of coastal zone management. Moreover, the application of CARLIT along years will allow to build a long-term dataset useful to assess the temporal and spatial variability of *Cystoseira* species in the light of monitoring and conservation of such assemblages.

Acknowledgments

Authors thank all colleagues of the Department State of the Environment and Ecosystems (“Area Mare”) who helped in the field. The present work is a contribution to the “Monitoring plan of the Sicilian marine and coastal waters” for the implementation of the Italian Legislative Decree (152/06)” within the “DAR project” funded by the Water and Waste Department of the Sicily Region.

References

- [1] AA.VV. (2008) - *Rapporto sulle attività relative al monitoraggio delle comunità fitobentoniche ai sensi del D.Lgs. 152/2006*, ARPA Sicilia, Technical Report, November 2008, pp. 1 - 55.
- [2] AA.VV. (2014) - *Progetto Caulerpa (Indagini ambientali e rilievi sulla diffusione della Caulerpa nel Canale di Sicilia)*, ARPA Sicilia, Technical Report, November 2014, pp. 1 - 80.
- [3] AA.VV. (2018) - *Convenzione per l'aggiornamento del quadro conoscitivo sullo stato di qualità delle acque sotterranee, superficiali, interne, superficiali, marino-costiere ai fini della revisione del piano di gestione del distretto idrografico della Regione Sicilia*, ARPA Sicilia, Technical Report, December 2018, pp. 1 - 630.

- [4] Airoldi L., Bulleri F. (2011) - *Anthropogenic disturbance can determine the magnitude of opportunistic species responses on marine urban infrastructures*, PLoS ONE 6 (8), e22985.
- [5] Arévalo R., Pinedo S., Ballesteros E. (2007) - *Changes in the composition and structure of Mediterranean rocky-shore communities following a gradient of nutrient enrichment: descriptive study and test of proposed methods to assess water quality regarding macroalgae*, Mar. Pollut. Bull. 55 (1), 104 - 113.
- [6] Badreddine A., Saab M.A.A., Gianni F., Ballesteros E., Mangialajo L. (2018) - *First assessment of the ecological status in the Levant Basin: Application of the CARLIT index along the Lebanese coastline*, Ecol. Indic. 85, 37 - 47.
- [7] Ballesteros E. (1992) - *Els vegetals i la zonació litoral: espècies, comunitats i factors que influeixen en la seva distribució*, Arxius Secció Ciències I.E.C. 101, 1 - 616.
- [8] Ballesteros E., Torras X., Pinedo S., Garcia M., Mangalajo M., De Torres M. (2007) - *A new methodology based on littoral community cartography dominated by macroalgae for the implementation of European Water Framework Directive*, Mar. Pollut. Bull. 55 (1), 172 - 180.
- [9] Bellissimo G., Rull Lluch J., Tomasello A., Calvo S. (2014) - *The community of Cystoseira brachycarpa J. Agardh emend. Giaccone (Fucales, Phaeophyceae) in a shallow hydrothermal vent area of the Aeolian Islands (Tyrrhenian Sea, Italy)*, Plant Biosyst. 148, 21 - 26.
- [10] Blanfuné A., Thibaut T., Boudouresque C.F., Mačić V., Markovic L., Palomba L., Verlaque M., Boissery P. (2017) - *The CARLIT method for the assessment of the ecological quality of European Mediterranean waters: Relevance, robustness and possible improvements*, Ecol. Indic. 72, 249 - 259.
- [11] Brondi A., Cicero A.M., Magaletti E., Giovanardi F., Scarpato A., Silvestri C., Spada E., Casazza G. (2003) - *Italian Coastal Typology for the European Water Framework Directive*, Proceedings of the Sixth International Conference on the Mediterranean Coastal Environment, MEDCOAST 03, E. Özhan (Editor), Ravenna, Italy, 7–11 October 2003, 1179 - 1190.
- [12] Bulleri F., Benedetti-Cecchi L., Acunto S., Cinelli F., Hawkins S.J. (2002) - *The influence of canopy algae on vertical patterns of distribution of low-shore assemblages on rocky coasts in the northwest Mediterranean*, J. Exp. Mar. Bio. Ecol. 267 (1), 89 - 106.
- [13] Colombo F., Costa V., Dubois S.F., Gianguzza P., Mazzola A., Vizzini S. (2013) - *Trophic structure of vermetid reef community: High trophic diversity at small spatial scales*, J. Sea Res. 77, 93 - 99.
- [14] De La Fuente G., Chiantore M., Gaino F., Asnaghi V. (2018) - *Ecological status improvement over a decade along the Ligurian coast according to a macroalgae based index (CARLIT)*, PLoS ONE 13 (12), e0206826.
- [15] Juanes J.A., Guinda X., Puente A., Revilla J.A. (2008) - *Macroalgae, a suitable indicator of the ecological status of coastal rocky communities in the NE Atlantic*, Ecol. Indic. 8 (4), 351 - 359.
- [16] Lasinio G.J., Tullio M.A., Ventura D., Ardizzone G., Abdelahad N. (2017) - *Statistical analysis of the distribution of infralittoral Cystoseira populations on pristine coasts of four Tyrrhenian islands: Proposed adjustment to the CARLIT index*, Ecol. Indic. 73, 293 - 301.

- [17] Mangialajo L., Ruggieri N., Asnaghi V., Chiantore M., Povero P., Cattaneo-Vietti R. (2007) - *Ecological status in the Ligurian Sea: the effect of coastline urbanisation and the importance of proper reference sites*, Mar. Pollut. Bull. 55 (1), 30 - 41.
- [18] Mangialajo L., Sartoni G., Giovanardi F. (2008) - *Quaderno metodologico sull'elemento biologico MACROALGHE e sul calcolo dello stato ecologico secondo la metodologia CARLIT*. In: ISPRA - Istituto Superiore per la Protezione e la Ricerca Ambientale, Rome, August 2008, p. 105.
- [19] Pinedo S., Garcia M., Satta M.P., De Torres M., Ballesteros E. (2007) - *Rocky-shore communities as indicators of water quality: a case study in the northwestern Mediterranean*, Mar. Pollut. Bull. 55 (1), 126 - 135.

TOWARDS NEW MARINE-COASTAL NATURA 2000 SITES IN THE CENTRAL ADRIATIC SEA

Maria Carla de Francesco^{1,2}, Igino Chiuchiarelli¹, Ludovico Frate²,
Maria Laura Carranza², Tommaso Pagliani², Angela Stanisci²

¹Abruzzo Region – Dep. Tourism, Culture and Landscape, Salaria Antica Est street, L’Aquila (Italy)

²University of Molise – Dep. Biosciences and Territory, Duca degli Abruzzi street, Termoli (Italy),

Corresponding Author: Maria Carla de Francesco e-mail: maria.defrancesco@unimol.it

Abstract – The Abruzzo coast is a particularly heterogeneous environment that host high levels of biodiversity to be preserved, that need of innovative sustainable management strategies. In that context, the project CALLIOPE (LIFE17 NAT/IT/000565) aims to improve the marine-coastal Natura 2000 Network in Abruzzo region (Italy). The main objectives of CALLIOPE are: improving the biodiversity knowledge of marine environments (Habitats and species of European Conservation concern – Habitat Directive-HD), testing integrated management strategies to increase the conservation of coastal-marine biodiversity and supporting the preparation of a Coastal Action Plan for the Abruzzo Region.

In this context this work presents the results of a study aimed at describing and mapping the marine-coastal habitats of conservation concern (according with Habitat Directive) in the central Adriatic coast (Abruzzo region).

This new information will support the proposal of two new Natura 2000 sites (pSIC Punta dell’Acquabella and the pSIC Ripari di Giobbe) and the extension of the perimeter of a ZSC towards the respective marine-coastal area (ZSC IT7140108 Punta Aderci-Punta della Penna). We identified and mapped the habitat “Sandbanks slightly covered by sea water all the time (HD-1110)” here dominated by the phanerogama *Cymodocea nodosa*, the habitat “Large shallow inlets and bays (HD-1160)” with the presence of phanerogama *Zostera noltii* inside a largest prairie of *Cymodocetum* association and in correspondence of rocky environments the habitat “Reefs (HD-1170) with several associated species.

The implementation of Natura 2000 Network in marine habitats seems the better way to protect these important and fragile environments and to enhance a sustainable development of Abruzzo coast.

Introduction

The Adriatic Sea is an important basin hosting numerous endemic species including marine mammals, sea turtles, sea birds, fish and invertebrates and its natural ecosystems have a key role on human well-being [18]. Due to its shallow water it represents an important nursery, reproduction and foraging habitats even on areas distant to the seashore [15]. It also hosts several benthic ecosystems included in the Habitat Directive (92/43/EEC, Annex) and most of them are seriously impinged by human activities as illegal fishing and commercial exploitation [9, 13, 16].

The global decline of marine ecosystems may be partially ascribed to a poor governance and to the lack of a consistent marine conservation policy [18]. Despite their

great biodiversity and ecosystems value and the need of protecting them, just the 5% of the Adriatic Sea is included in Marine Protected Areas. MPAs are an effective instrument for preserving marine habitats and related fauna as well as for protecting cetaceans' populations [3]. In this context, new actions and instruments aimed at improving and conserving marine ecosystems to maintain and promote their sustainability in the Adriatic Sea are urgently needed [28]. To propose and implement a Marine Protected Areas (MPAs) or a marine SCI's several issues must be assembled. First a good scientific knowledge supporting management planners are needed. In particular, the delineation of critical habitats represents an important step [4, 17]. Besides ecological knowledge, to preserve marine environments and to develop sustainable activities it is also necessary to engage some focused communities and stakeholders in the process of safeguarding activities [29, 30].

In order to meet these needs, the project CALLIOPE (LIFE17 NAT/IT/000565) aims to improve the coast-sea regional natural connectivity by improving the Natura 2000 Network. In particular, the presented research focuses on improving knowledge about marine habitats in three target sites along the southern Abruzzo coast. Such new information is essential for proposing and implementing integrated coastal-marine Natura 2000 sites in the Abruzzo coast. Based on such new data we also offer the bases for improving public awareness on environmental protection all necessary for delineating a Regional Action Plan for the marine-coastal habitats.

The description and distribution of the Adriatic benthic communities have been studied at coarse scale [31, 32, 33, 34]; and large scale benthic surveys in the northern Adriatic soft bottoms were carried out in the '60s and '90s. The analysis of this data over time evidenced a reduction of benthic community's spatial heterogeneity (i.e. a reduction in diversity from local to medium scale) and such results were related with the increased trawling fishing pressure and with a variation in sedimentation patterns [27]. Shallow inshore sandy bottoms are often dominated by the suspension-feeding bivalve *Lentidium mediterraneum*, which seasonally can reach very high densities (300 000 ind. m² [1, 2]. The eastern coasts of Adriatic Sea, dominated by rocky shores are covered by benthic assemblages of photophilic algae, including *Cystoseira spp.* belts, and sea urchin barrens. Near the rocky shores, especially in shallow bays, there are seagrass meadows, as deeper subtidal rocky cliffs are covered by peculiar coralligenous habitats and by date mussel *Lithophaga lithophaga*. The principal reef-forming organisms in these coasts are algae as *Lithophyllum incrustans*, *Lithothamnion spp.* and *Peyssonnelia spp.* communities. Reefs are dominated by algal turfs and boring sponges close to the seashore, while offshore by benthic communities with high biodiversity values. The composition of the reef benthic communities is heterogeneous and varies over time and across sites in correspondence with different geo-morphological features and local environmental variables [12, 24, 25]. Instead, the Central Adriatic area is less investigated and a unified framework describing the benthic communities living on soft bottoms is still necessary.

In this context this work presents the results of a preliminary study aimed at describing and mapping the marine-coastal habitats of conservation concern (according with Habitat Directive 92/43/EEC) in the central Adriatic coast (Abruzzo region). This new information will support the proposal of two new Natura 2000 sites (pSIC Punta dell'Acquabella-Foce fiume Moro and the pSIC Ripari di Giobbe-Foce fiume Foro) and the extension of the perimeter of ZSC towards the respective marine-coastal area (ZSC IT7140108 Punta Aderci-Punta della Penna).

Materials and Methods

The Abruzzo coast (central Adriatic sub-basin) is a particularly heterogeneous environment characterized by sandy beaches and dune habitats in the northern and in the southern sectors, and shallow rocky cliffs and pebbly beaches in the central-southern part. The main promontories are Punta Ferruccio and Ripari di Giobbe (within the Ripari di Giobbe Regional Nature Reserve), Punta Acquabella (within the Punta dell'Acquabella Regional Nature Reserve) and Punta Aderci (within the ZSC IT7140108 Punta Aderci-Punta della Penna) [22]. Information on marine biocoenoses and local biodiversity along the Abruzzo coast, with the exception of the AMP Torre del Cerrano (ZSC IT7120215) seabed, are poor and not exhaustive for structuring management programs [10, 11, 16]. This work focused on the marine-coastal areas that are facing the Regional Natural Reserves Punta dell'Acquabella and Ripari di Giobbe in Ortona (CH) and the ZSC IT7140108 "Punta Aderci-Punta della Penna" in Vasto (CH) (Figure 1).

Before collecting new data and planning an updated biodiversity survey we gathered existing information and official documents describing naturalistic value of the analysed areas. We systematized biodiversity information reported on Management Plans; Scientific-Technical reports; Natura 2000 Standard Forms; maps included in the Management Plans and Scientific publications.

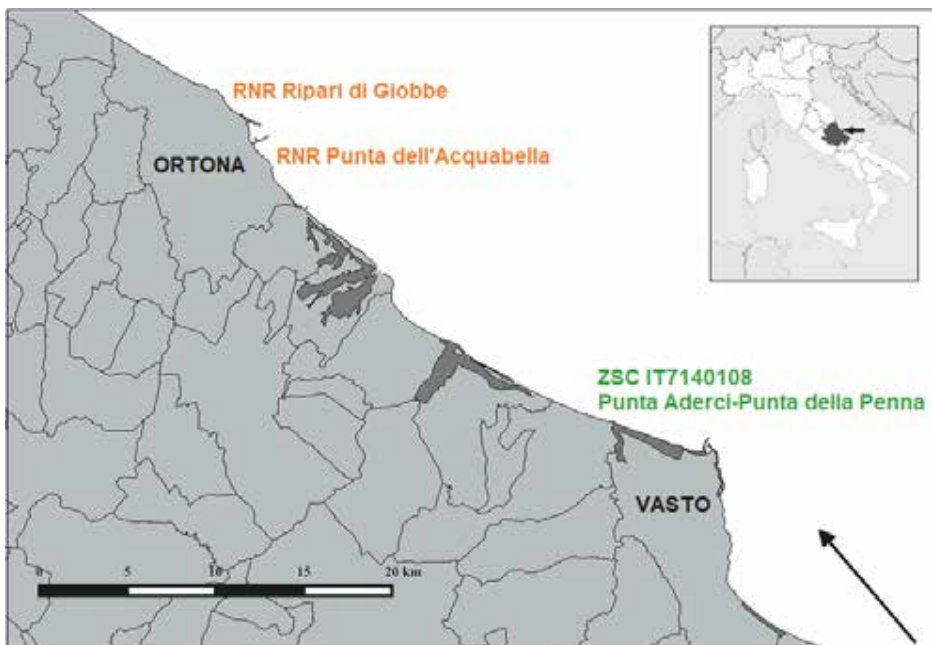

Figure 1 - Ripari di Giobbe Regional Natural Reserve, Punta dell'Acquabella Regional Natural Reserve in Ortona (CH) and Punta Aderci-Punta della Penna SAC (ZSC IT7140108) in Vasto (CH). In dark grey the current N2000 regional network.

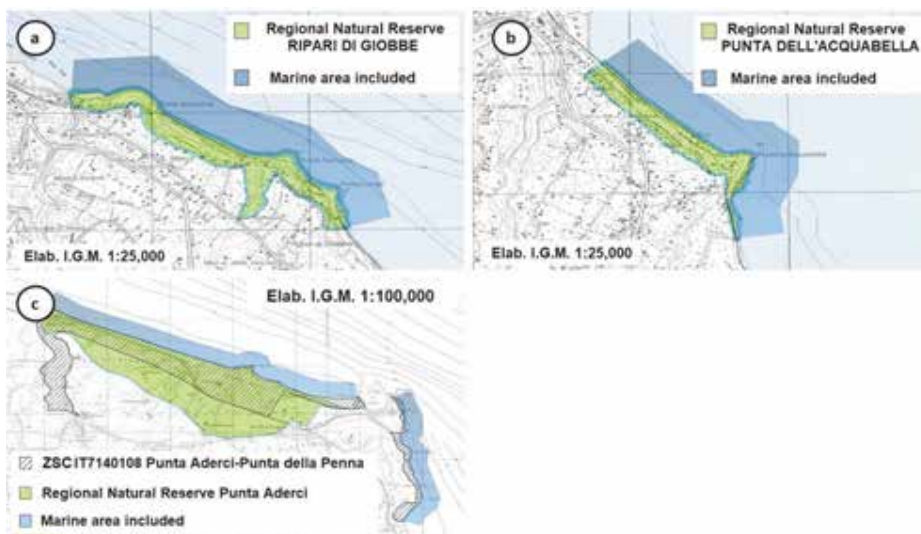

Figure 2 - Localization of marine-coastal pSCI's a) Ripari di Giobbe; b) Punta dell'Acquabella in Ortona (Ch) Protected Areas and c) the Punta Aderci-Punta della Penna site (ZSC IT7140108).

We defined the sampling area for each site as a 500 m buffer from the shore to the open sea (Figure 2). The sampling area was defined in a GIS environment (QGIS 3.8.3) based on the "AreeProtette" layer made available by the Abruzzo Region (Web Map Service in EPSG 4326 - WGS 84 – Geographic). To better analyze the stratification of marine associations [19], we also considered bathymetric information extracted from bathymetry map of the Adriatic Sea (contour 1m) – ISMAR CNR, 2016 (WMS).

A preliminary map of the of EU (92/43/EEC) marine habitats distribution in the analyzed coastal area was prepared using orthophotos and images available in the various specialized web services, including: Google Earth Pro; Google Maps; National Cartographic Portal; ADRIPLAN; SHAPE Adriatic Atlas; COPERNICUS Marine Environment Monitoring Service; E-Geos Realvista 1.0.

For the detailed identification and assignment of EU habitats, scuba diving was carried out following the guidelines of the Italian Habitats Manual [5]. Based on such information we also prepared a checklists of EU habitats and of associated fauna occurring in the target areas. Such information was georeferenced and established as monitoring sites (10 in Punta dell'Acquabella, 10 in Ripari di Giobbe, 19 in Punta Aderci).

Results

The survey on marine sea floor at -7÷-10 m depth, up to 300÷500 m from the seashore, evidenced a fine sand well calibrated bank with marine phanerogams. Specifically, we identified the EU habitat 1110 (Sandbanks which are slightly covered by sea water all

the time) with seabed without vegetation or with marine phanerogama *Cymodocea nodosa* (Figure 3a) for a total coverage of 347,6 ha. The most important species of fauna occurring in these sandbanks are *Hippocampus hippocampus*, the short snouted seahorse, and benthic species as bivalves *Chamelea gallina*, *Lentidium mediterraneum*, gasteropods *Nassarius mutabilis*, *N. reticulatus*, *Bolinus brandaris*, *Aporrhais pespelecani*, echinoderms *Atropecten irregularis*, *Holoturia tubulosa*, and crustaceans *Diogenes pugilator*, *Illia nucleus*, *Liocarcinus vernalis*.

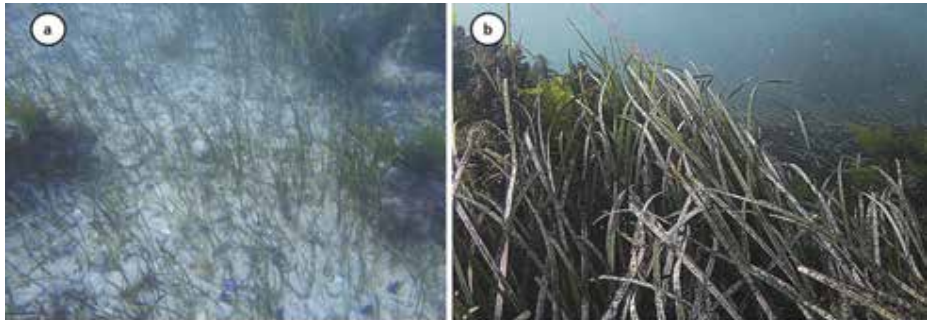

Figure 3 - (a) EU 1160 with *Zostera noltii*; (b) EU 1110 with *Cymodocea nodosa*.

We also registered the presence of the EU habitat 1160 (Large shallow inlets and bays) with the marine phanerogama *Zostera noltii* with a total coverage of 0,61 ha (Figure 3b) occurring within a larger prairie of *Cymodocetum nodosae*. This habitat was observed only on the Punta Aderci site. The association *Zosterion marinae* includes the phanerogamic vegetation that develops on banks of muddy sands in calm, shallow and low salinity waters. This habitat is very important, because it represents a coastal nursery area where the juveniles of numerous necto-benthic fish species converge during the early stages of growth before spreading along the coast and then reaching sexual maturity [20]. In fact, the shallow waters allow the concentration of *Sparidae* (*Diplodus vulgaris*, *Diplodus annularis*, *Lythognathus mormyrus*, *Dicentrarchus labrax*), *Serranids* (*Epinephelus* sp., *Serranus scriba* and *Serranus cabrilla*) and red mullets *Mullus barbatus*.

The EU habitat 1110 and 1160 represent important fish nursery areas. As fish and several marine species depend on those habitats to survive and to reproduce, they are essential for preserving both: biodiversity and fishery activities [26].

Concerning the sampled rocky environments that characterize the cliffs we have registered the presence of the Reefs EU habitat (code 1170) with that has an estimated cover of 36,63 ha.

This cliffs host colonies of *Sabellaria spinulosa* (Figure 4), that forms bio-constructions on the rocks, and of various associated species including *Leptogorgia sarmentosa*, *Cladocora coespitosa* (Figure 5a, b), *Balanophyllia europea*, the bryozoan *Schizoporella errata*, the sea urchins *Aracia lixula* and *Paracentrodon lividus*, the bivalve common piddock *Pholas dactylus* and the bivalve species in Annex IV of the Habitats Directive (92/43/EEC) date mussel *Lithophaga lithophaga* (Figure 5c) and *Pinna nobilis* (Figure 5d).



Figure 4 - Bio-construction with *Sabellaria spinulosa*.

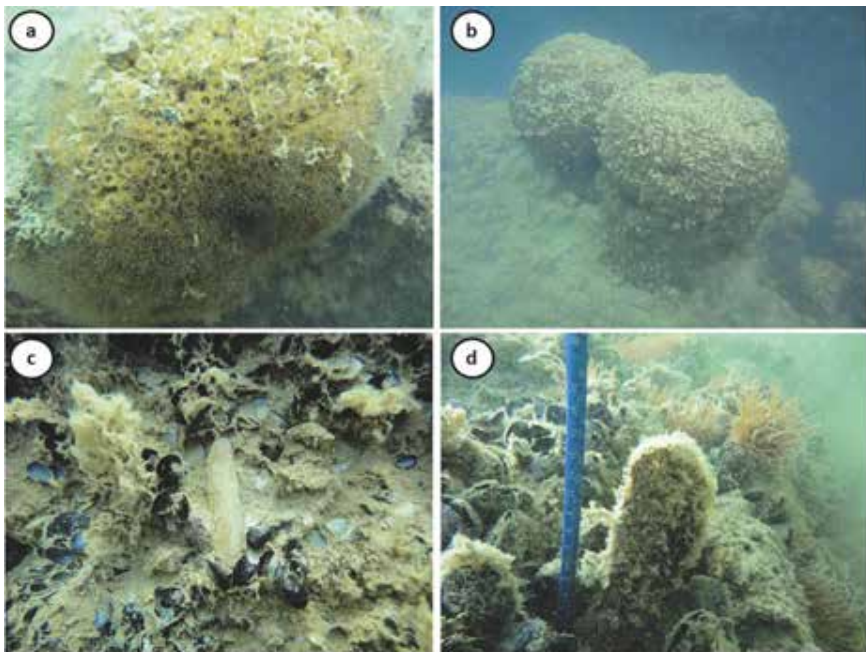

Figure 5 - a) and b) *Cladocora coespitosa* specimens; c) *Lithophaga lithophaga*; d) *Pinna nobilis*.

There are also numerous seaweeds including *Peyssonelia sp.* (Figure 6a), *Dictyopteris membracea*, *Dictyota dichotoma* and, only for the Punta Aderci site, of the rhodophytic *Halymenia floresia* (Figure 6b), which forms real grasslands on the seabed.

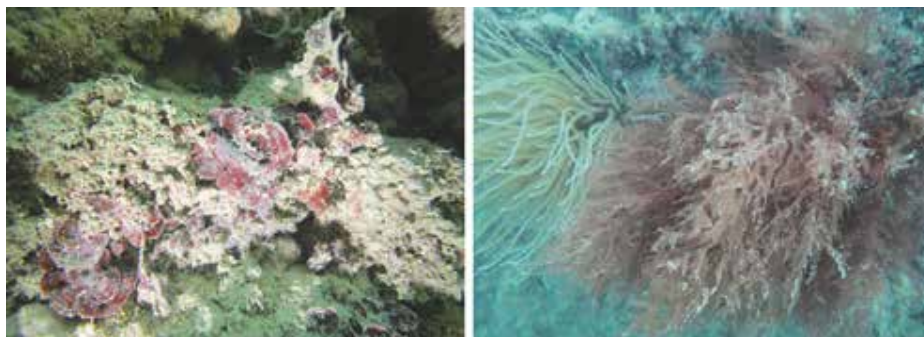

Figure 6 - (a) *Peyssonelia* sp., (b), *Halymenia floresia*.

All the produced georeferenced information was included in the Integrated Territorial Information System of LIFE17 CALLIOPE project¹ that, together with other cartographic information, will contribute to the comprehensive vision of the Abruzzo coast biodiversity and will support the definition of an Integrated Coastal Management Plan.

Discussion

As seen in other site of Adriatic coasts [8], the analyzed areas host a significant level of biodiversity with high number of benthic species living in shallow waters. We found and mapped several species protected by national or international Directives, and as observed in other areas such variability is most likely related with a high heterogeneity of bottom sediments [12, 24, 25]. The predominant seabed sediments are sandy-muddy [6, 7] with short sections where rocks form promontories in the southern tract of Abruzzo coast [21, 22]. As observed in the northern Adriatic coast also in the Abruzzo region we found sandbanks (EU habitat 1110) mainly with sandy sediments intermingled in some areas with large grain sediments as boulders and cobbles, and with small grained ones including mud in other. Such conditions allow the presence of EU habitat 1110 which hosts the typical “Biocoenosis of fine sands” (SFBC, well calibrated fine sands, code III.2.2) and EU habitat 1170, hosting the “Biocoenosis of infralittoral algae” (code III.6.1). Our results confirm the presence of a marine environments mosaic with sandbanks and reefs.

Our first results about LIFE17 NAT/IT/000565 CALLIOPE represent an important step for collecting data and information useful for implementing the marine-coastal Natura 2000 Network in central Adriatic basin.

Conclusion

The observed marine habitats in the analysed coast are of considerable importance for the maintenance of marine biodiversity supplying several ecological functions as

¹ <http://envixlab.unimol.it/life-calliope-il-sistema-informativo-integrato/>
https://drive.google.com/drive/folders/1wzlmHvEOamveKUIHo53e3c52UN_sxXIC

nursery for fish food, phytopurification capacity of marine waters, containment of storm surges, for increasing the landscape-perceptive value and tourism appeal, among others [29, 30]. Reducing the loss of natural habitats cover and quality represent, here and in general, a huge challenge in science, conservation and management [23], and this work support effective conservation measures.

The implementation of Natura 2000 Network in marine habitats seems the better way to protect these important and fragile environments, combining the conservation of biodiversity with sustainable tourism and sustainable utilization of resources. The here reported information may help to identify adequate measures for reducing the negative effects of several activities impinging coastal integrity over time as those derived from the destruction of the environment, the unauthorized removal of marine species and the construction of artificial artifacts for tourism.

The next step of LIFE17 NAT/IT/000565 CALLIOPE project will be a realization of a Regional Management Plan for implementing conservation actions and socio-economic strategies to preserve all Natura 2000 Network sites along Abruzzo coast. The Plan will be realized through a participative process, which will involve citizens and local stakeholders, according to the UN 2030 Agenda for Sustainable Development.

Acknowledgments

We thank the LIFE+ program (LIFE17 NAT/IT/000565 CALLIOPE “Coastal dune habitats, subLittoral sandbanks, marine reefs: conservation, Protection, and threats mitigation”) for European co-financing and Abruzzo region (Coordinator Beneficiary) for the support in the development of the foreseen actions. We thank Mrs. Alessia Felizzi of COGECSTRE cooperative (responsible of Punta Aderci Natural Reserve, Abruzzo) for the moral and financial support to the preliminary analysis. We thank both Municipalities of Vasto and Ortona where we are working for implementation of Natura 2000 marine network.

References

- [1] Ambrogi R., Bedulli D., Zuriñi G. (1990) – *Spatial and Temporal Patterns in Structure of Macrobenthic Assemblages. A Three-Year Study in the Northern Adriatic Sea in Front of the Po River Delta*. Mar. Ecol. 11(1), 25-41.
- [2] Ambrogi R., Curti L., Parisi V. (1985) – *Le ricerche ecologiche nel Delta del Po: stato delle conoscenze, problemi, obiettivi e coordinamento*. Atti Seminario di studi sull'Ecologia del Delta del Po, Parma 1985. Nova Thalassia 7 (2), 7-26.
- [3] Awbery T., Baş A.A., Clark H., Nikpaljevic N., Abbiss L., Clarkson J., Hardy J., Guimard E., Beqiri K., Konomi A. (2019) – *The Identification of Critical Habitats for Cetaceans in the Southern Adriatic Sea*, World Marine Mammal Conference 2019 DOI: 10.13140/RG.2.2.12955.21281
- [4] Balmford A., Bruner A., Cooper P., Costanza R., Farber S., Green R.E., Jenkins M., Jefferiss P., Jessamy V., Madden J., Munro K., Myers N., Naeem S., Paavola J., Rayment M., Rosendo S., Roughgarden J., Trumper K., Turner R.K. (2002) – *Economic reasons for conserving wild nature*, Science, 297(5583): 950-3.

- [5] Biondi E., Blasi C., Burrascano S., Casavecchia S., Copiz R., Del Vico E., Galdenzi D., Gigante D., Lasen C., Spampinato G., Venanzoni R., Zivkovic L. (2009) – *Manuale Italiano di Interpretazione degli Habitat della Direttiva 92/43/CEE*. Società Botanica Italiana-Ministero dell’Ambiente e della Tutela del Territorio e del Mare. Direzione Protezione della Natura.
- [6] Brambati A., Ciabatti M., Fanzutti G.P., Marabini F., Marocco R. (1983) – *A new sedimentological textural map of the northern and central Adriatic Sea*. *Boll. Oceanogr. Teor. Appl.* 1(4), 267-271.
- [7] Brambati A., Venzo G.A. (1967) – *Recent sedimentation in the northern Adriatic Sea between Venice and Trieste*. *Studi Trent. Sci. Nat.* 44(2), 202-274.
- [8] Cerrano C., Bakran-Petricioli T., Bastari A., Frascchetti S., Huete-Staufffer C., Ferretti F., Valisano L. (2016) – *Adriatic Sea: Description of the Ecology and Identification of the Areas that May Deserve to be Protected*. United Nations Environment Programme/ Mediterranean Action Plan (UNEP/MAP)-Regional Activity Centre for Specially Protected Areas (RAC/SPA), Tunis, Urednici: Cebrian D., Requena S.
- [9] Coll M., Piroddi C., Albouy C., Lasram F.B.R., Cheung W.W.L., Christensen V., Karpouzi V.S., Guilhaumon F., Mouillot D., Paleczny M., Palomares M.L., Steenbeek J., Trujillo P., Watson R., Pauly D. (2012) – *The Mediterranean Sea under siege: spatial overlap between marine biodiversity, cumulative threats and marine reserves*, *Glob Ecol Biogeogr* 21: 465-480. doi: 10.1111/j.1466-8238.2011.00697.x
- [10] Colantoni P., Gabbianelli G., Mancini F., Bertoni W. (1997) – *Coastal defence by breakwaters and sea-level rise: The case of the Italian Northern Adriatic Sea*. *Bull. Inst. Oceanogr. (Monaco)*, 133- 150.
- [11] Colantoni P., Mencucci D., Nesci O. (2004) – *Coastal processes and cliff recession between Gabicce and Pesaro (northern Adriatic Sea): a case history*. *Geomorphology* 62(3-4), 257-268.
- [12] Curiel D., Falace A., Bandelj V., Kaleb S., Solidoro C., Ballesteros E. (2012) – *Species composition and spatial variability of macroalgal assemblages on biogenic reefs in the northern Adriatic Sea*. *Bot. Mar.* 55(6).
- [13] Devescovi M., Ozretić B., Iveša L. (2005) – *Impact of date mussel harvesting on the rocky bottom structural complexity along the Istrian coast (northern Adriatic, Croatia)*. *J. E xp. Mar. Biol. Ecol.* 325(2), 134-145.
- [14] de Francesco M.C., Cerrano C., Pica D., D'Onofrio D., Stanisci A. (2017) – *Characterization of Teatina Coast Marine Habitats (Central Adriatic Sea) toward an Integrated Coastal Management*. *OFOAJ* 5. doi:10.19080/OFOAM.2017.05.555653.
- [15] de Juan S., Leonart J. (2010) – *A conceptual framework for the protection of vulnerable habitats impacted by fishing activities in the Mediterranean high seas*. *Ocean Coast Manag* 53(11), 717-723.
- [16] Fanelli G., Piraino S., Belmonte G., Geraci S., Boero F. (1994) – *Human predation along Apulian rocky coasts (SE Italy): Desertification caused by Lithophaga lithophaga (Mollusca) fisheries*. *Mar Ecol Prog Ser* 110(1), 1-8.
- [17] Farella G., Menegon S. Fadini A., Depellegrin D., Manea M., Perini L., Barbanti A. (2020) – *Incorporating ecosystem services conservation into a scenario-based MSP framework: An Adriatic case study*, *Ocean & Coastal Manag* 193, 105230.

- [18] Frascchetti S., Terlizzi A., Micheli F., Benedetti-Cecchi L., Boero F. (2002) – *Marine Protected Areas in the Mediterranean: objectives effectiveness and monitoring*. Mar Ecol 23 (1): 190-200
- [19] Giaccone G., Alongi G., Cossu A., Di Geronimo R., Serio D. (1993) – *La vegetazione marina bentonica del Mediterraneo: I. Sopralitorale e mesolitorale. Proposte di aggiornamento*, Boll. Accad. Gioenia Sci. Nat. Catania, 26 (341): 145-172.
- [20] Loriente E. (1974) – *Sobre la vegetación de las clases Zosteretea y Spartinetea maritimae de Santander*, Anal. Inst. Bot. Cavanilles 31(2): 179-189.
- [21] McKinney F.K. (2007) – *The Northern Adriatic ecosystem - Deep time in a shallow sea*. Columbia University Press, New York, 299 pp.
- [22] Miccadei E., Mascioli F., Piacentini T., Ricci F. (2011) – *Geomorphological features of coastal dunes along the central Adriatic coast (Abruzzo, Italy)*, J Coast Res 27 (6), 1122-1136. DOI: 10.2112/JCOASTRES-D-10-00161.1.
- [23] Perkol-Finkel S, Airoidi L (2010) – *Loss and Recovery Potential of Marine Habitats: An Experimental Study of Factors Maintaining Resilience in Subtidal Algal Forests at the Adriatic Sea*, PLoS One. 2010; 5(5): e10791. doi: 10.1371/journal.pone.0010791
- [24] Ponti M., Falace A., Rindi F., Fava F., Kaleb S., Abbiati M. (2014) – *Beta diversity patterns in northern Adriatic coralligenous outcrops.*, in: Proceedings of the 2nd Mediterranean symposium on the conservation of the coralligenous and other calcareous bio-concretions, Portorož, Slovenia, 29- 30 October 2014. Bouafif, C., Langar, H., Ouerghi, A. (Eds.). RAC/SPA, pp. 147-152.
- [25] Ponti M., Fava F., Abbiati M. (2011) – *Spatial-temporal variability of epibenthic assemblages on subtidal biogenic reefs in the northern Adriatic Sea*. Mar. Biol. 158(7), 1447-1459.
- [26] Ross S. W. (2002) – *Relative value of different estuarine nursery areas for juvenile marine fishes in North Carolina*, Fish. Bull. 101:384–404
- [27] Scardi M., Crema R., Di Dato P., Fresi E. e Orel G. (2000) – *Le comunità bentoniche dell'Alto Adriatico: un'analisi preliminare dei cambiamenti strutturali dagli anni '30 ad oggi*, In: O Giovanardi (ed.), Proceedings of the Workshop "Impact of trawl fishing on benthic communities", Rome, 19/11/1999, p. 95-108
- [28] Simeoni U., Bondesan M. (1997) – *The role and responsibility of man in the evolution of the Italian Adriatic coast*, in: Commission internationale pour l'exploration scientifique de la mer Méditerranéenne, Science Series n° 3: Transformations and evolutions of the Mediterranean coastline. Briand, F., Maldonado, F. (Eds.). Bulletin de l'Institut Océanographique 18, Monaco, pp 75-96.
- [29] Tonin S. (2018) – *Citizens' perspectives on marine protected areas as a governance strategy to effectively preserve marine ecosystem services and biodiversity*, Ecosyst Serv, 34, DOI: 10.1016/j.ecoser.2018.03.023
- [30] Tonin S., Lucaroni G. (2017) – *Understanding social knowledge, attitudes and perceptions towards marine biodiversity: The case of tegnùe in Italy*, Ocean & Coastal Manag, 140:68-78. DOI: 10.1016/j.ocecoaman.2017.02.019
- [31] Vatova A. (1946) – *Le zoocenosi bentoniche dell'Adriatico*. Boll. Pesca, Pisc., Idrobiol 1(2), 131-135.
- [32] Vatova A. (1949) – *La fauna bentonica dell'Alto e Medio Adriatico*. Nova Thalassia 1(3), 1-110.

- [33] Vatova A. (1958) – *Condizioni idrografiche dell'Alta Laguna Veneta*. Nova Thalassia 2(8), 1-114.
- [34] Vatova A. (1960) – *Condizioni idrografiche e fasi di marea nell'Alta Laguna Veneta*. Nova Thalassia 2(9), 1-59.

Sitography

<http://www.adriaticplusplatform.eu/it>

<http://www.eea.europa.eu/themes/water/europes-seas-and-coasts/ocean-governance/ocean-governance#eea-marine-roadmap>

<http://geoportale.regione.abruzzo.it/Cartanet>

<https://marine.copernicus.eu/services-portfolio/product-improvements/>

<http://www.pcn.minambiente.it/>

<http://www.realvista.it/>

<http://www.reportingdirettivahabitat.it/downloads>

<http://www.shape-ipaproject.eu/>

<http://www.torredelcerrano.it/lamp-torre-del-cerrano-in-natura-2000.html>

SEASONAL DYNAMICS OF CADMIUM AND PLUMBUM IN THE TURIYA AND PRIPYAT RIVERS

Halyna Humeniuk¹, Olena Voloshyn¹, Volodymyr Voloshyn²

¹Ternopil Volodymyr Hnatiuk National Pedagogical University (Ukraine)

Phone +380674033137, e-mail: gumenjuk@chem-bio.com.ua

²I. Horbachevsky Ternopil National Medical University (Ukraine)

Abstract – The anthropogenic pressure on aquatic ecosystems leads to a significant transformation of their quantitative and qualitative composition. Many rivers of Ukraine are polluted. The object of research was the surface waters of the rivers Pripyat and Turiya (Volyn region, Ukraine). Analysis of the qualitative and quantitative composition of toxicants (Cd, Pb) showed that the waters of the rivers have high level of pollution. A negative phenomenon in the studied reservoirs is a significant excess of concentrations of heavy metals: lead in 118 times and cadmium in 110 times in August.

Introduction

The constantly growing anthropogenic pressure on aquatic ecosystems Plumbum to disruption of the natural regimes of rivers development and a significant transformation of their quantitative and qualitative composition. Rivers play a very important role in the life of the city's communities, satisfying household, industrial and technical needs, and recreation. Today, most of the rivers in Ukraine in general and in Volyn region in particular, are polluted. The rivers Pripyat and Turiya are not exception. They belong to the Dnieper basin. In recent years, in particular in 2012, 2015, and in 2016, the media discussed issues of environmental degradation of the main waterway of the Kovel district – Turiya river and identifying sources of its pollution. Now, in the context of the economic crisis, the production activities of most enterprises in Kovel and in particular Platan-enterprise, have drastically reduced water demand and, accordingly, reduced wastewater volumes. At the same time, the acute problem of Turiya river - widespread violation and non-compliance with the water protection regime in the settlements of its basin, in particular in the Kovel city [1, 2, 3].

Heavy metals (HMs) are one of the most dangerous components of surface water pollution in Ukraine. They differ from organic substances, are not susceptible to degradation and are constantly in one form or another in aquatic ecosystems and therefore significantly affect the quality of water and the functioning of biotas. Accumulation of HMs in water bodies depends not only from the geological structure of the rocks, but also from the type of water body, its hydrological regime, and seasonal fluctuations of the physicochemical parameters of water. The most bioavailable and dangerous are metal compounds dissolved in water [9, 13].

Nonessential heavy metals, especially those with variable valences, such as Cadmium and Plumbum, exhibit a direct toxic effect on organisms.

Materials and methods of research

The objects of research were the surface waters of the Pripyat and Turiya rivers of the Volyn region.

Water samples were taken from the surface horizon of water bodies in the middle of the river at a depth of $0.5 \div 0.7$ m using plastic samplers with a volume of 1 dm^3 .

To study the content of heavy metals in water, samples were taken in 5 different places of the Turiya river (Fig. 1). Also, samples were taken for study in 5 different places of the Pripyat River (Fig. 2).



Figure 1 - The beginning of the Shchytyń village; 2 – near the buildings; 3 - near the beach; 4 - near the watering place; 5 - the mouth of Turiya river falls in the Pripyat river.

Water was filtered through a membrane filter with a pore diameter of $0.45 \mu\text{m}$. The concentrations of heavy metals were determined by the ion-selective potentiometric method using the EB-74 ion meter [14, 15].

Statistical processing of the data was carried out using the software package Statistica 5.5 and Microsoft Office Excel 2010.

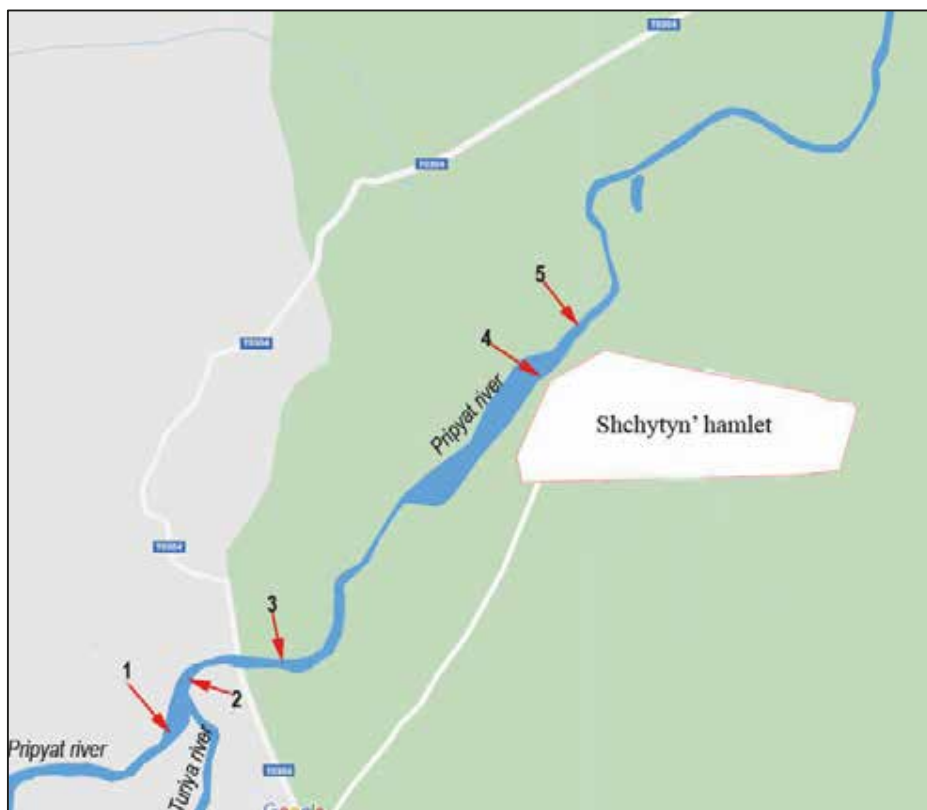

Figure 2 - 1- The Pripyat river before the mouth of Turiya river; 2 - near the beach; 3 - near the watering place; 4 - near the buildings; 5 - the end of the Shchytyyn' village.

Results of research and discussion

The natural waters are a dynamic chemical system that contains a complicated complex of gases, mineral and organic substances in the form of true solutions, suspensions and colloids. Its condition depends not only from environmental conditions, but also from various processes occurring both from outside and inside the hydrosystem [5].

Metal ions are integral components of the chemical composition of surface waters. Unlike organic pollutants, they do not decompose, but undergoing changes, are redistributed between the components of the ecosystem, constantly being in it [7].

Plumbum is one of the most toxic and most dangerous heavy metals. It enters river waters together with aerosol particles from industrial enterprises resulting from the combustion of coal and oil products, with waste water from the metallurgical and chemical industries. Plumbum mainly is absorbed in water systems. It is associated with suspended particles. Plumbum may also be in the form of soluble complexes with humic acids [13].

The features of the distribution and migration of Plumbum are due to the intensity of deposition and complexation. In addition, significant amounts of heavy metal enter in aquatic ecosystems as part of automobile emissions.

The most important role among various migratory forms of HMs, including Plumbum, belongs to water-soluble compounds. Exactly their number determines the intensity of the inclusion of Plumbum in a small biological cycle.

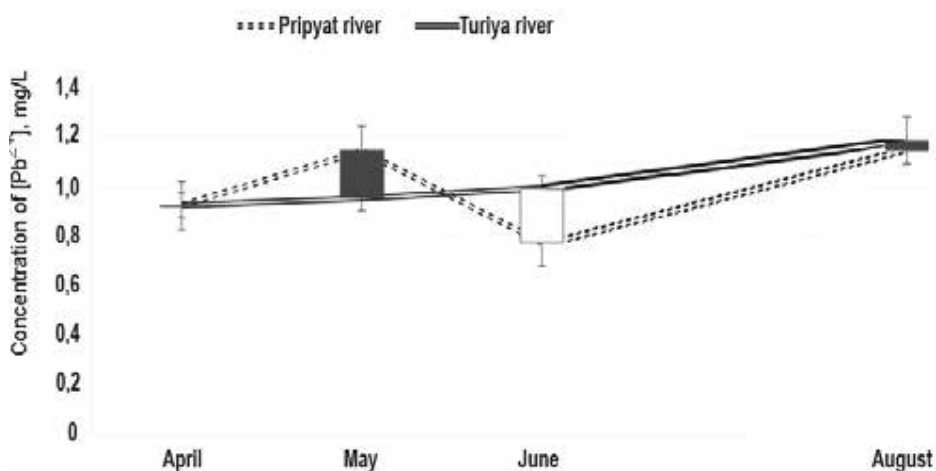

Figure 3 - The Plumbum content in the water of the rivers of the Volyn region, in April-August 2018, ($M \pm m$; $n = 5$)

In all water bodies of the studied territories, an excess of the *maximum permissible concentration* (MPC) of Plumbum was found ($MPC (Pb) = 0.01 \text{ mg/dm}^3$) [4].

In August, the concentration of Plumbum in the Pripjat River exceeded the maximum permissible concentration by 118 times. In both reservoirs, the concentration of Plumbum increased from April to August, which may be due to rains and flushing from the soil surface. In our opinion, a significant concentration of Plumbum in August is associated with the process of methylation of inorganic compounds of Plumbum in bottom sediments, contributes to the mobilization of this element from the sludge. As you know, plants absorb a certain amount of HMs and at the end of the growing season fall into the lower parts of the reservoir. They decompose there and cause secondary pollution of the water, giving it HMs, nutrients and organic matter [8].

Cadmium is one of the most harmful substances that pollute the aquatic environment (Fig. 4). For Cadmium (II), unlike Plumbum (II), weighted forms of migration are less characteristic, which on average account for about 65 % of the world's river flow [10]. Cadmium migrates in a dissolved state, because it binds to complexes weakly [11, 12].

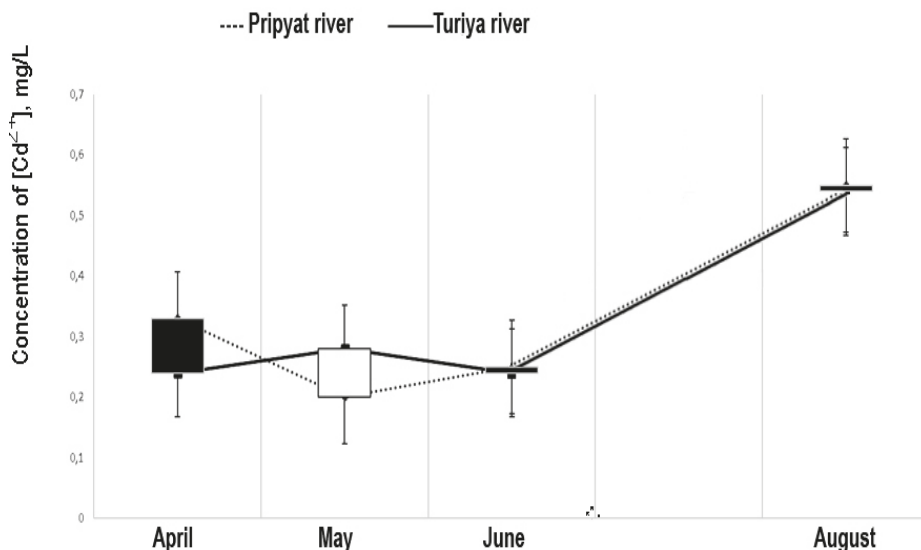

Figure 4 - Cadmium content in the water of the rivers of the Volyn region in April-August 2018, ($M \pm m$; $n = 5$).

In all water objects of the studied territories, an excess of the MPC for Cd was founded (MPC (Cd) = 0.005 mg/dm³ in norm [4, 6]).

In particular, in August in the Pripjat River we observed the concentration of Cadmium MPC exceeding 110 times the norm. The Cadmium concentration is quite high and biohazardous due to the extremely high toxicity of this metal, which is also a mutagen. The increase in Cadmium content can be caused by a relatively low oxygen content during this period, which causes the influx of metals from bottom sediments as a result of their recovery (under conditions of oxygen deficiency) and good solubility of its compounds in water.

Conclusions

So, taking into account the qualitative and quantitative composition of toxicants (Cd, Pb), it can be argued that the waters of the studied small Volyn rivers have a rather high level of pollution. A negative fact in the studied reservoirs is a significant excess of heavy metal concentrations: Plumbum by 118 times and Cadmium by 110 times in August.

According to the environmental classification of surface water quality in Ukraine according to the degree of anthropogenic pollution of the Turiya and Pripjat rivers belong to category V (very dirty).

Knowledge of the spatial and temporal distribution of heavy metals among the components of aquatic ecosystems is important for assessing the quality of natural waters, identifying pollution sources and assessing the level of their impact on aquatic ecosystems.

This allows rationally organize a system of environmental monitoring of the state of the water objects.

References

- [1] Anonymous - *Pro stan vody r. Turiya u mistyakh masovoho vidpochynku na vodi* [About the state of water of the Turia-river in the places of mass recreation on the water] (Electronic resource)/Access mode: <http://www.volindses.com.ua> [in Ukraine].
- [2] Anonymous - *Promyslova ekolohiya. Tekhnolohiyi zakhystu navkolysn'oho seredovyscha* [Industrial ecology. Environmental Protection Technologies] (Electronic resource) / Access mode: <http://eco.com.ua/content/osnovni-shlyakhi-zakhystu-vodnikh-resursiv> [in Ukraine].
- [3] Anonymous - *Rehional'ni dopovidi pro stan navkolysn'oho seredovyscha* [Regional Reports about the State of the Environment] (Electronic Resource) / Access Mode: <https://menr.gov.ua/news/31778.html> [in Ukraine].
- [4] Anonymous (1990) - *Hranychno dopustymi znachennya pokaznykiv yakosti vody dlya rybohospodars'kykh vodoym. Zahal'nyy perelik HDK i OBRV shkidlyvykh rehovyn dlya vody rybohospodars'kykh vodoym* [Maximal allowable values of water quality indicators for fishery reservoirs. The general list of MAC [Maximum Allowable Concentrations] and ELSE [Estimated Levels of Safe Exposure] of harmful substances for water of fishery reservoirs] (No. 12-04-11 09/08/1990), M.: Ministry of Fish Industry of USSR. [in Russia].
- [5] Byyak V.Y., Lyavrin B.Z., Khomenchuk V.O., Kurant V.Z. (2010) - *Analiz hidrokhimichnykh pokaznykiv malykh richok Zakhidnoho podillya* [Analysis of hydrochemical indicators of small rivers in the Western Podillia], Scientific notes of Ternop. nat. ped Un-sity Ser. Biol. 4 (45), 115-121. [in Ukraine].
- [6] Dudnikova I.I., Pushkin S.P. (2007) - *Monitorynh dovkillya* [Environmental Monitoring], K.: Publishing House of the European University, Part 2. [in Ukraine].
- [7] Fedonenko O.V., Esipova N.B. (2004) - *Suchasnyy promyslovyy ikhtiokompleks Zaporiz'koho vodoskhovyscha ta yoho kharakterystyka* [Modern industrial ichthyo complex of Zaporizhzhya reservoir and its characteristic], K.: Fish Industry No. 63, 242-245. [in Ukraine].
- [8] Humeniuk H.B. (2003) - *Rozpodil vazhkykh metaliv u hidroekosystemi prisnoi vodoimy (na prykladi Ternopil'skoho stavu)* [Heavy metals distribution in hydroecosystem of fresh water (on the example of Ternopil lake)] Ph.D. dissertation (ecology). Chernivtsi. [in Ukraine].
- [9] Kholopov Yu. A. (2003) - *Tyazhelye metally kak faktor ekologicheskoy opasnosti* [Heavy metals as a factor of environmental hazard], Samara: SamGAPS. [in Russia].
- [10] Linnik P.N. (1999) – *Tyazholyye metally v poverkhnostnykh vodakh Ukrainy: sodержaniye i formy migratsii* [Heavy metals in the surface waters of Ukraine: content and forms of migration], Hydrobiological journal, V.35, 1, 22–42. [in Ukraine].
- [11] Linnik P.N., Nabivanets B.I. (1986) - *Formy migratsii metallov v presnykh poverkhnostnykh vodakh* [Forms of metal migration in unleavened surface waters], L.: Gidrometeoizdat. [in Russia].
- [12] Linnik P.N., Zubko A.V., Zubenko I.B., Ignatenko I.I., Malinovskaya L.A. (2009) - *Vliyaniye pH na migratsiyu razlichnykh form metallov v sisteme «donnyye otlozheniya-voda» v eksperimental'nykh usloviyakh* [The effect of pH on the migration of various forms of metals in the system of "bottom sediment-water" in experimental conditions], Hydrochemistry, V.45, 1, 99–109. [in Russia].

- [13] Moor D., Ramamurti S. (1987) - *Tyazhelyye metally v prirodnykh vodakh. Kontrol' i otsenka vliyaniya* [Heavy metals in natural waters. Control and assessment of influence], M.: Mir. [in Russia].
- [14] Novikov Yu.V., Lastochkina K.O., Boldin Z.N. (1990) - *Metody issledovaniya kachestva vody vodoyemov* [Methods of research of water quality of reservoirs] / Yu.V. Novikov, - M.: Medicine. [in Russia].
- [15] Romanenko V.D., Zhukinsky V.M., Oksiyuk O.P. (1998) - *Metodyka ekolohichnoyi otsinky yakosti poverkhnevyykh vod za vidpovidnymi katehoriyamy* [Method of ecological assessment of surface water quality according the relevant categories], M.: [in Russia].

PHYTOPLANKTON ASSEMBLAGE CHARACTERIZATION ALONG THE MEDITERRANEAN COAST OF MOROCCO DURING AUTUMN

Hajar Idmoussi^{1,2}, Laila Somoue², Karim Hilmi², Omar Ettahiri²,
Tarik Baibai², Ahmed Makaoui², Ahmed Errhif¹

¹Faculté des Sciences Ain Chock, Université Hassan II, B.P. 5366, Maarif, Casablanca, 20100,
(Morocco), phone +212 6 53 82 42 05, e-mail: hajar.idmoussi@gmail.com

²Institut National de Recherche Halieutique, Bd Sidi Abderrahmane 2, Ain Diab
Casablanca, 20100, (Morocco)

Abstract – The present study aimed to assess the composition, abundance and diversity of phytoplankton assemblage along the Moroccan Mediterranean coast. Phytoplankton samples were collected in October 2018 at 48 stations from M'diq bay in the West to Saïdia in the East, using Niskin bottles in the surface. Its identification and enumeration were carried out using the Utermöhl method. 92 taxa have been inventoried along the study area belonging to five groups. Diatoms dominate qualitatively and quantitatively (85.5 %) the total microalgal population during this period. It is mainly represented by *Leptocylindrus danicus*, *Pseudonitzschia* spp. and *Chaetoceros* spp., followed by dinoflagellates (12 %) where *Gymnodinium* spp., *Katodinium* spp., *Diplopsalis* spp. and *Amphisolenia* spp. were the most abundant species. The other groups (euglenophyceae, raphidophyceae and coccolithophoridae) were poorly represented.

The phytoplankton abundance varied from 8×10^2 cells L⁻¹ to 598×10^2 cells L⁻¹. Shannon and evenness indices showed respectively (broadly $H > 3$ bits and $J > 0.8$). High values of phytoplankton abundance and diversity were located in the western part of Moroccan Mediterranean Sea, especially (from Jebha to M'diq) because of the influence of the Atlantic flow.

Introduction

In the Mediterranean coast of Morocco, fishing is considered as one of the main social and economical activities mainly small pelagic species in terms of biomass and commercial interest [1-2]. However, anthropogenic disturbances increased by human activities and warming waters caused by climate change are having a major impact on the biological components and has obviously an impact on fisheries resources occurring in a very complex and vulnerable ecosystem [3-4-5-6]. The latter is limited by the strait of Gibraltar where the Atlantic Jet enters and feeds two anticyclonic Alboran gyres (Est-West) [7], giving specific properties [8]. These properties make indeed changes on phytoplankton composition.

Because it is considered as a basic component, changes on its composition could be influenced by their surrounding environment [9] and affected directly the energy source and ecological stability for zooplankton, ichthyoplankton and the other links of the food web [10-11].

Until now, phytoplankton studies in this ecosystem still scarce [12-13]. The present investigation will allow to acquire a scientific knowledge (composition, abundance and

diversity) of this first link of the marine food web, which have a major impact on biodiversity and local fisheries resources as well as on the world climate through its contribution to ocean carbon sequestration [14].

Materials and methods

An oceanographic survey was conducted in October 2018 along the Mediterranean coast of Morocco and a total of 48 stations were sampled in surface (Figure 1). These were located from Saïdia to M'diq. Phytoplankton was made from 100 ml of sea water collected with Niskin bottles and fixed using lugol. The identification and enumeration of phytoplankton was performed according to Utermöhl method [15] under a Nikon inverted microscopy. The phytoplankton densities were expressed in cells L⁻¹.

The occurrence (F) was calculated [16], to classify the identified species into three groups: i-) constant species ($F \geq 50\%$); ii-) accessory species ($25\% \leq F < 50\%$) and iii-) incidental species ($F < 25\%$).

For ecological indices, the species richness (Rs) is the number of species present in each station, the species diversity was investigated according to Shannon (H) and Pielou (J) [17-18]. The Community dominance index (CDI) [19] was estimated to determine the percentage of abundance contributed to a community by two most abundant species. H ranges from 0 to infinity. J ranges from near 0 (which indicates low evenness or high single-species

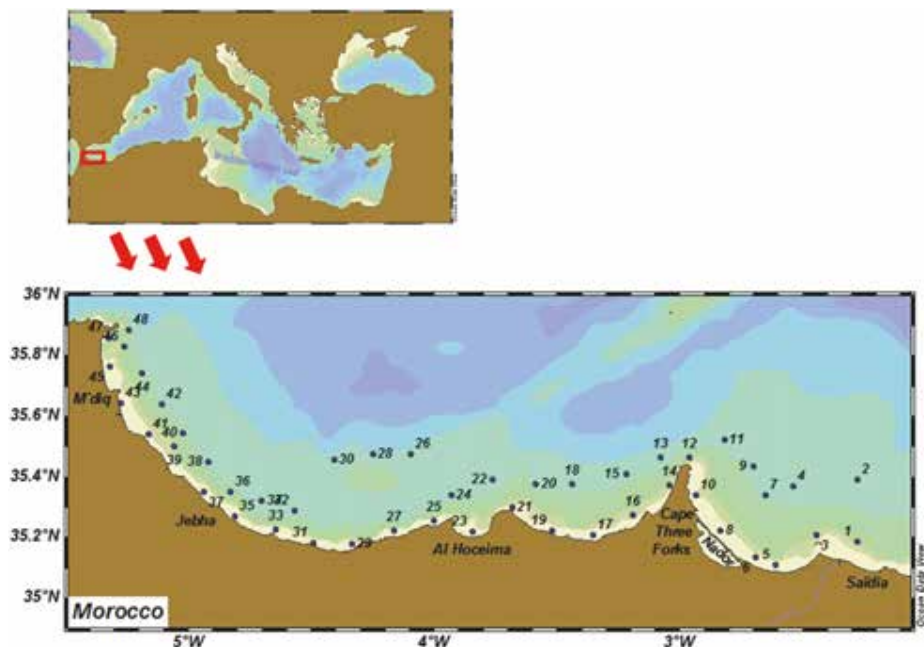

Figure 1 - The investigated areas with sampling sites located in the Moroccan Mediterranean coast.

dominance), to 1 (which indicates equal abundance of all species or maximum evenness). CDI values range between 0 and 100.

For statistical analyses, MDS (Multi Dimensional Scaling) analyses were performed to evaluate association between stations, based on the total phytoplankton abundance using PRIMER (version. V) Software, with a Bray-Curtis similarity index [20].

Results

In October 2018, the phytoplankton in the study area is composed of 92 taxa, belonging to five groups (Table I). Diatoms represented by 42 species, dinoflagellates (46 species) and 1 species for each other group (euglenophyceae, raphidophyceae, silicoflagellates and coccolithophoridae).

Table 1 - The list of phytoplankton species along the Moroccan Mediterranean coast during October 2018.

Group	Genera	Species
Diatoms	<i>Achnanthes</i>	<i>Achnanthes</i> spp.
	<i>Actinocyclus</i>	<i>Actinocyclus octonarius</i>
	<i>Amphora</i>	<i>Amphora</i> spp.
	<i>Asterolampra</i>	<i>Asterolampra</i> spp.
	<i>Asterionellopsis</i>	<i>Asterionellopsis glacialis</i>
	<i>Baccillaria</i>	<i>Baccillaria</i> spp.
	<i>Bacteriastrum</i>	<i>Bacteriastrum</i> spp.
	<i>Chaetoceros</i>	<i>Chaetoceros</i> spp.
	<i>Cocconeis</i>	<i>Cocconeis</i> spp.
	<i>Corethron</i>	<i>Corethron</i> spp.
	<i>Cylindrotheca</i>	<i>Cylindrotheca closterium</i>
	<i>Cymatopleura</i>	<i>Cymatopleura</i> spp.
	<i>Dactyliosolen</i>	<i>Dactyliosolen fragilissimus</i>
	<i>Diploneis</i>	<i>Diploneis</i> spp.
	<i>Eucampia</i>	<i>Eucampia</i> spp.
	<i>Fragilaria</i>	<i>Fragilaria</i> spp.
	<i>Hemiaulus</i>	<i>Hemiaulus</i> spp.
	<i>Guinardia</i>	<i>Guinardia delicatula</i>
		<i>Guinardia flaccida</i>
		<i>Guinardia phuketensis</i>
		<i>Guinardia striata</i>
	<i>Lauderia</i>	<i>Lauderia annulata</i>
	<i>Leptocylindrus</i>	<i>Leptocylindrus danicus</i>
		<i>Leptocylindrus minimus</i>
	<i>Licmophora</i>	<i>Licmophora</i> spp.
	<i>Melosira</i>	<i>Melosira</i> spp.
	<i>Meuniera</i>	<i>Meuniera</i> spp.
	<i>Navicula</i>	<i>Navicula</i> spp.
	<i>Nitzschia</i>	<i>Nitzschia</i> spp.
		<i>Nitzschia longissima</i>
	<i>Paralia</i>	<i>Paralia</i> spp.
	<i>Planktoniella</i>	<i>Planktoniella</i> spp.

(Continued in next page)

(Continued from previous page)

	Proboscia	<i>Proboscia alata</i>	
	Pseudo-nitzschia	<i>Pseudo-nitzschia</i> spp.	
	Rhizosolenia	<i>Rhizosolenia bergoni</i> <i>Rhizosolenia setigera</i>	
	Tabellaria	<i>Tabellaria</i> spp.	
	Thalassionema	<i>Thalassionema nitzschoides</i>	
	Thalassiosira	<i>Thalassiosira</i> spp.	
	Synedra	<i>Synedra</i> spp.	
Dinoflagellates	Actiniscus	<i>Actiniscus pentasterias</i>	
	Alexandrium	<i>Alexandrium</i> spp. <i>Alexandrium tamarense</i>	
	Amphidinium	<i>Amphidinium</i> spp.	
	Amphisolenia	<i>Amphisolenia</i> spp.	
	Cochlodinium	<i>Cochlodinium</i> spp.	
	Dinophysis	<i>Dinophysis caudata</i> <i>Dinophysis acuminata</i>	
	Phalacroma	<i>Phalacroma rotundatum</i>	
	Diplopsalis	<i>Diplopsalis</i> spp.	
	Fibrocapsa	<i>Fibrocapsa japonica</i>	
	Gonyaulax	<i>Gonyaulax</i> spp.	
	Gymnodinium	<i>Gymnodinium catenatum</i> <i>Gymnodinium sanguineum</i>	
	Gyrodinium	<i>Gyrodinium fusus</i> <i>Gyrodinium spirale</i>	
	Heterocapsa	<i>Heterocapsa</i> spp.	
	Karenia	<i>Karenia</i> spp.	
	karlodinium	<i>Karlodinium veneficum</i>	
	Katodinium	<i>Katodinium</i> spp.	
	Metaphalacroma	<i>Metaphalacroma</i> spp.	
	Noctulica	<i>Noctulica</i> spp. <i>Noctulica scintillans</i>	
	Ostreopsis	<i>Ostreopsis</i> spp.	
	Oxyphysis	<i>Oxyphysis</i> spp.	
	Oxytoxum	<i>Oxytoxum</i> spp.	
	Pronoctulica	<i>Pronoctulica</i> spp.	
	Prorocentrum	<i>Prorocentrum balticum</i> <i>Prorocentrum gracile</i> <i>Prorocentrum lima</i> <i>Prorocentrum micans</i> <i>Prorocentrum minimum</i> <i>Prorocentrum rostratum</i>	
	Protoperidinium	<i>Protoperidinium depressum</i> <i>Protoperidinium diabolus</i> <i>Protoperidinium quinquecorne</i> <i>Protoperidinium steinii</i>	
	Pyrophacus	<i>Pyrophacus</i> spp.	
	Scrippsiella	<i>Scrippsiella</i> spp.	
	Torodinium	<i>Torodinium</i> spp.	
	Tripes	<i>Tripes candelabrum</i> <i>Tripes furca</i> <i>Tripes fusus</i> <i>Tripes muelleri</i>	
	Euglenophyceae	Eutreptiella	<i>Eutreptiella</i> spp.
		Euglena	<i>Euglena</i> spp.
	Coccolithophoridae	Coccolithus	<i>Coccolithus</i> spp.
	Raphidophyceae	Chattonella	<i>Chattonella</i> spp.

The species Occurrence showed that 4 taxa among the 92 identified were constant in the area ($F \geq 50\%$). These include *Nitzschia* spp., *Tabellaria* spp., *Pseudo-nitzschia* spp. and *Cylindrotheca closterium*. 15 species were accessory ($25 \leq F < 50$) such as *Gymnodinium* spp., *Leptocylindrus minimus*, *Katodinium* spp., *Chaetoceros* spp., *Scrippsiella* spp., *Amphisolenia* spp., *Heterocapsa* spp., *Euglena* spp.. The rest of the taxa were accidental ($F < 25\%$).

Diatoms dominate qualitatively and quantitatively (85.5 %) the microalgal Mediterranean population during this period. It is mainly represented by *Leptocylindrus danicus*, *Pseudonitzschia* spp. and *Chaetoceros* spp., followed by dinoflagellates (12 %) where *Gymnodinium* spp., *Katodinium* spp., *Diplopsalis* spp. and *Amphisolenia* spp. were the most abundant species. The other groups (euglenophyceae, raphidophyceae and coccolithophoridae) were poorly represented.

Total densities of phytoplankton varied from 8×10^2 cells L^{-1} to 598×10^2 cells L^{-1} . The high values were founded in the Western Mediterranean coast of Morocco, especially (between Jebha and M'diq) (Figure 2).

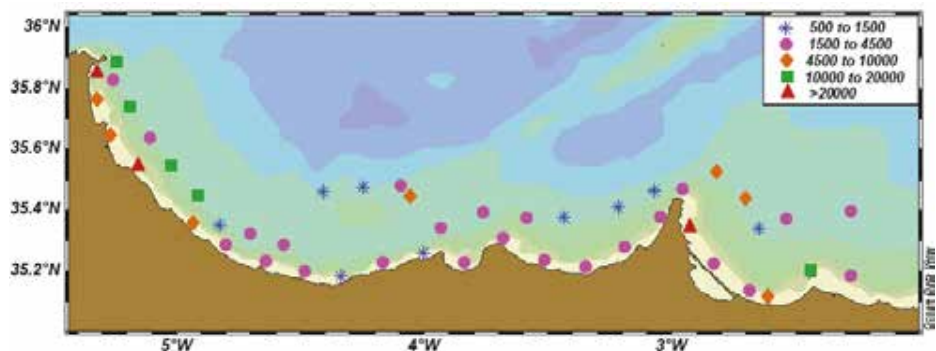

Figure 2 - Distribution of phytoplankton density in sampled stations (cells L^{-1}) collected during October 2018 along Moroccan Mediterranean coast.

Ecological indices (Figure 3) based on species richness and diversity were used to describe community structure and change. Species richness was generally (>15 taxa) with high values (27 species) recorded in the west region (particularly between Jebha and M'Diq) (Figure 3A). The diversity indices (Shannon index (H) and Evenness index (J)), showed a high diversity along the studied ecosystem (generally: $H > 3$ bits and $J > 0.8$) (Figure 3B and C). A maximum of H and J were respectively 4bits and 0.98 located from Hoceima to M'diq Bay. Stations where less diversity reveals high values of community dominance index (CDI), proving the dominance of some taxa to the detriment of others (Figure 3C).

Based on the distribution of total microalgal abundance, the MDS analysis plot (Figure 4) showed two groups of stations corresponded to two geographical areas. Group I included 33 stations located generally in the Western area (Three Forks cape – M'diq), characterized by high to medium densities. Group II included 15 stations, corresponding to the Eastern area (Saïdia-Three Forks cape), characterized by low population.

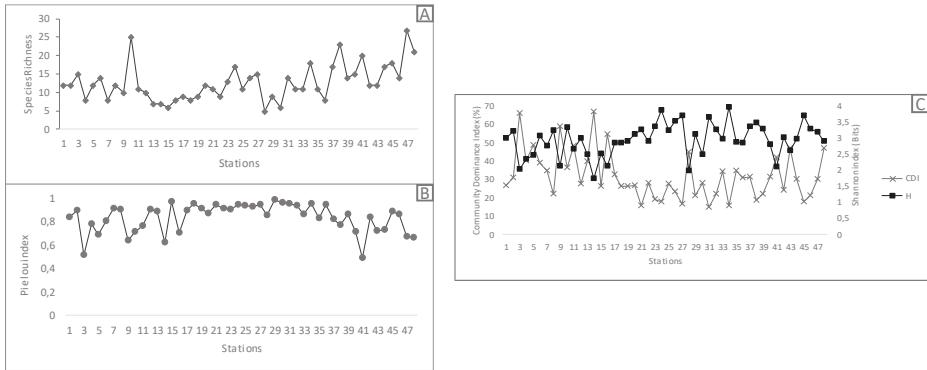

Figure 3 - Comparing ecological indices (A: Species richness, B: Pielou and C: Shannon - Community Dominance Index) in sampling stations (St1-48: Saïdia- M'diq).

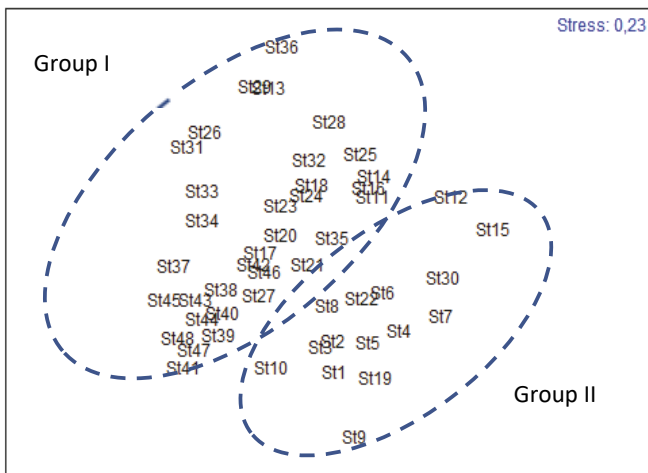

Figure 4 - Stations grouping obtained by performing a MDS analysis based on total phytoplankton abundance.

Discussion

The Mediterranean coast of Morocco is more productive because of water exchange between Atlantic and Mediterranean through strait of Gibraltar [21].

The inflow of Atlantic Jet (AJ) may explain this productivity [7] which is in accordance with the fact that the highest phytoplankton abundance was mostly recorded at coastal and neritic stations (Figure 2), especially in the West region (between Jebha and M'diq).

According to the autumn season, 92 species of microphytoplankton were identified along the Mediterranean coast of Morocco with the dominance of diatoms followed by

dinoflagellates. This finding is in agreement with previous studies in the Mediterranean [22-23-24] and Atlantic ecosystem [25-26-27-28]. Reference [29] reported that this statement of diatoms was maintained in turbulent water masses whereas dinoflagellates need relatively well stratified waters for their optimal growth. *Leptocylindrus danicus*, *Pseudo-nitzschia* spp., *Chaetoceros* spp., *Tabellaria* spp., *Leptocylindrus minimus*, *Nitzschia* spp., *Cylindrotheca closterium*, *Guinardia striata*, *Gymnodinium* spp., *Katodinium* spp., *Diplopsalis* spp. and *Amphisolenia* spp. were the most abundant phytoplankton species. It is considered that *Leptocylindrus danicus*, *Chaetoceros* spp., *Leptocylindrus minimus*, *Guinardia striata* and *Katodinium* spp. were endemic to the Atlantic Ocean [28] while the other species were widespread except *Amphisolenia* spp. found particularly in the western area. This latter proliferates mainly in tropical waters [30]. Its abundance could be explained by the increase in temperature during this season. Shannon index determines not only diversity but also pollution status of water body [31]. This index ranges 1.74-3.97 bits, it is clear that the studied area shows moderate pollution level and the higher values indicated greater species diversity that proves these smallest differences in abundance between communities.

The ecological indices highlighted that the spatial distribution of phytoplankton community is clearly visible, diversified and equitable mainly in the west region (from Cape Three Forks to M'diq). In the Moroccan Mediterranean Sea, phytoplankton diversity and abundance were very pronounced in the western part because of the influence of the Atlantic flow. A confrontation of the hydrological variables will be established in order to identify the impact of environmental factors determining the phytoplankton variability in the study area and subsequently the biological resource.

Acknowledgments

Authors are very thankful to the program coordinators of Marine Plankton Ecology Laboratory in the National Institute of Fisheries Research. The authors also thank the entire team that participated in the survey aboard the Moroccan Research Vessel "Al Amir Moulay Abdellah".

References

- [1] FAO. (2016) - *The State of Mediterranean and Black Sea Fisheries*, General Fisheries Commission for the Mediterranean, Rome 134 pp. ISBN: 978-92-5-109159-3 <http://www.fao.org/3/a-i5496e.pdf>.
- [2] Palomera, I., Olivar M.P., J. Salat, Sabatés A., M. Coll, García A., Morales-Nin B. (2007) - *Small Pelagic Fish in the NW Mediterranean Sea: An Ecological Review*, Progress in Oceanography 74 (2-3): 377-96. <https://doi.org/10.1016/j.pocean.2007.04.012>.
- [3] Coll M., Piroddi C., Steenbeek J., Kaschner K., Lasram F. B. R., Aguzzi J., Ballesteros E., et al. (2010) - *The Biodiversity of the Mediterranean Sea: Estimates, Patterns, and Threats*, édité par Steven J. Bograd. PLoS ONE 5 (8): e11842. <https://doi.org/10.1371/journal.pone.0011842>.

- [4] FAO (2008) - *Report of the FAO Expert Workshop on Climate Change Implications for Fisheries and Aquaculture*, Rome, Italy, 7–9 April 2008. FAO Fisheries Report. No. 870. Rome, FAO. 2008. 32p. ISBN: 978-92-5-106347-7
- [5] Perry A., Low P., Ellis J., Reynolds J. (2005) - *Climate Change and Distribution Shifts in Marine Fishes*, *Science* 308: 1912–15. <https://doi.org/10.1126/science.1111322>.
- [6] Garcia-Martinez M.C., Vargas-Yáñez M., Moya F., Zunino P., Bautista B. (2018) - *The Effects of Climate Change and Rivers Damming in the Mediterranean Sea during the Twentieth Century*, *Research Journal of Environmental Sciences* 8. <https://doi.org/10.19080/IJESNR.2018.08.555741>.
- [7] Renault, L., Oguz T., Pascual A., Vizoso G., Tintore J. (2012) - *Surface Circulation in the Alborán Sea (Western Mediterranean) Inferred from Remotely Sensed Data: surface circulation in the Alborán Sea*, *Journal of Geophysical Research: Oceans* 117 (C8): n/a-n/a. <https://doi.org/10.1029/2011JC007659>.
- [8] Vargas-Yáñez, M., Plaza F., Lafuente J., Sarhan T., Vargas J.M., Velez-Belchi P. (2002) - *About the seasonal variability of the Alboran Sea circulation*, *Journal of Marine Systems* 35: 229–48. [https://doi.org/10.1016/S0924-7963\(02\)00128-8](https://doi.org/10.1016/S0924-7963(02)00128-8).
- [9] Rahaman S., Golder J, Rahaman M., Hasanuzzaman A., Huq KA, Begum S., Islam S., Bir J. (2013) - *Spatial and Temporal Variations in Phytoplankton Abundance and Species Diversity in the Sundarbans Mangrove Forest of Bangladesh* *Marine Science Research and Development*. 3 (126). <https://doi.org/10.4172/2155-9910.1000126>.
- [10] Duarte P., Macedo M. F., Cancela da Fonseca L. (2006) - *The Relationship between Phytoplankton Diversity and Community Function in a Coastal Lagoon*, In *Marine Biodiversity: Patterns and Processes, Assessment, Threats, Management and Conservation*, édité par K. Martens, H. Queiroga, M. R. Cunha, A. Cunha, M. H. Moreira, V. Quintino, A. M. Rodrigues, J. Seroôdio, et R. M. Warwick, 3-18. *Developments in Hydrobiology*. Dordrecht: Springer Netherlands. https://doi.org/10.1007/1-4020-4697-9_1.
- [11] Tiwari A., Chauhan S. V. S. (2006) - *Seasonal Phytoplanktonic Diversity of Kitham Lake, Agra*, *Journal of Environmental Biology* 27 (1): 35–38. ISSN: 0254-8704. http://www.jeb.co.in/journal_issues/200601_jan06/paper_06.pdf.
- [12] CAR/ASP. (2012) - *Rapport synthétique de la liste «Prioritaire» des sites méritant une protection au niveau des côtes méditerranéennes au Maroc*, Par Bazairi H., Mellouli M., Aghnaj A., El Khalidi K. et Limam A. Ed. CAR/ASP- Projet MedMPAnet, Tunis : 60 pp. + ANNEXES.
- [13] Mercado J. M., Ramírez T., Cortés D., Sebastián M., Vargas-Yáñez M. (2005) - *Seasonal and Inter-Annual Variability of the Phytoplankton Communities in an Upwelling Area of the Alborán Sea (SW Mediterranean Sea)*, *Scientia Marina* 69 (4): 451–65. <https://doi.org/10.3989/scimar.2005.69n4451>.
- [14] Park J.-Y., Kug J.-S., Bader J., Rolph R., Kwon M. (2015) - *Amplified Arctic warming by phytoplankton under greenhouse warming*, *Proceedings of the National Academy of Sciences of the United States of America* 112 (19). <https://doi.org/10.1073/pnas.1416884112>.
- [15] Utermöhl H. (1958) - *Zur Vervollkommnung der quantitativen Phytoplankton-Methodik*. *Mitt int. Verein, theor, angew. Lim - nol*. 9: 1-38.
- [16] Dajoz R. (2000) - *Précis d'écologie*, Edition Dunod. Paris. 615 p.

- [17] Shannon, C. E., Wiener W. (1949) - *The Mathematical Theory of Communication*, Urbana: University of Illinois Press.
- [18] Pielou, E. C. (1966) - *Species-diversity and pattern-diversity in the study of ecological succession*, *Journal of Theoretical Biology*, 10, 370–383.
- [19] Krebs, C.J. (1994) - *Ecology: The Experimental Analysis of Distribution and Abundance*, 4th edn, Harper Collins, New York.
- [20] Teer Brak, C.J.F., Prentice, I.C. (1988) - *A theory of gradient analysis*, *Advances In Ecological Research*, 18, 272-313.
- [21] Varkitzi, I., Francé, J., Basset, A., Cozzoli, F., Stanca, E., Zervoudaki, S., Giannakourou, A., Assimakopoulou, G., Venetsanopoulou, A., Mozetič, P., Tinta, T., Skejic, S., Vidjak, O., Cadiou, J.F., Pagou, K. (2018) - *Pelagic habitats in the Mediterranean Sea: a review of Good Environmental Status (GES) determination for plankton components and identification of gaps and priority needs to improve coherence for the MSFD implementation*, *Ecol. Ind.* 95, 203–218. <https://doi.org/10.1016/j.ecolind.2018.07.036>
- [22] Draredja M. A., Frihi H., Boualleg C., Gofart A., Abadie E., Laabir M. (2019) - *Seasonal Variations of Phytoplankton Community in Relation to Environmental Factors in a Protected Meso-Oligotrophic Southern Mediterranean Marine Ecosystem (Mellah Lagoon, Algeria) with an Emphasis of HAB Species*, *Environmental Monitoring and Assessment* 191 (10): 603. <https://doi.org/10.1007/s10661-019-7708-5>.
- [23] Salhi, N., Zmerli Triki H., Molinero J.C., Laabir M., Sehli E., Bellaaj-Zouari A., Daly Yahia N., Kefi-Daly Yahia O. (2018) - *Seasonal Variability of Picophytoplankton under Contrasting Environments in Northern Tunisian Coasts, Southwestern Mediterranean Sea*, *Marine Pollution Bulletin* 129 (2): 866-74. <https://doi.org/10.1016/j.marpolbul.2017.10.029>.
- [24] Daoudi M., Serve L., Rharbi N., El Madani F., Vouvé F. (2012) - *Phytoplankton distribution in the Nador lagoon (Morocco) and possible risks for harmful algal blooms* *Transitional Waters Bulletin* 6 (1): 4-19. <https://doi.org/10.1285/i1825229Xv6n1p4>.
- [25] Elghrib H., Somoue L., t Elkhiati N., Berraho A., Makaoui A., Bourhim N., Salah S., Ettahiri O. (2012) - *Phytoplankton distribution in the upwelling areas of the Moroccan Atlantic coast localized between 32°30'N and 24°N*, *Comptes rendus biologies* 335: 541 - 54. <http://dx.doi.org/10.1016/j.crv.2012.07.002>.
- [26] Somoue L., Elkhiati N., Vaquer A., Ramdani M., Ettahiri O., Makaoui A., Berraho, A. (2003) - *Contribution à l'étude des diatomées dans l'écosystème pélagique côtier au sud de l'atlantique marocain (21°N- 26°30'N)*, *Journal de Recherche Océanographique*, Vol. 28, pp. 1–13.
- [27] Somoue, L. (2004) - *Structure des communautés planctoniques de l'écosystème pélagique de l'Atlantique sud marocain entre Cap Boujdor et Cap Blanc (26°30' – 1°N)*, PhD Thesis, Faculty of Science Ain Chock, University Hassan II Casablanca, Morocco: 211 pp.
- [28] Demarcq, H., Somoue, L. (2015) - *Phytoplankton and primary productivity off Northwest Africa*, In: *Oceanographic and biological features in the Canary Current Large Marine Ecosystem*. Valdés, L. and Déniz-González, I. (eds). IOC-UNESCO, Paris. IOC Technical Series, No. 115, pp. 161-174. <http://hdl.handle.net/1834/9186>.

- [29] Tilstone G. H., Martín Míguez B., Figueiras F. G., Fermin E. G. (2000) - *Diatom Dynamics in a Coastal Ecosystem Affected by Upwelling: Coupling between Species Succession, Circulation and Biogeochemical Processes*, Marine Ecology Progress Series 205: 23-41. <https://doi.org/10.3354/meps205023>.
- [30] Saifullah S., Hina Baig H., Mansoor S. (2002) - *The Dinoflagellate genus *Amphisolenia* Stein from north Arabian Sea shelf of Pakistan*, Pakistan Journal of Botany 34: 69-76.
- [31] Wilhm, J. L., Dorris T. C. (1968) - *Biological Parameters for Water Quality Criteria*, BioScience 18 (6): 477-81. <https://doi.org/10.2307/1294272>.

SENTINEL-2 E CAMPIONAMENTI *IN SITU* PER IL MONITORAGGIO DELLE ACQUE MARINE DELL'ABRUZZO: PRIMI RISULTATI

Carla Ippoliti¹, Susanna Tora¹, Carla Giansante^{1,2}, Romolo Salini¹, Federico Filipponi³, Emanuela Scamosci², Massimo Petrini², Nicola Di Deo², Annamaria Conte¹

¹Istituto Zooprofilattico Sperimentale dell'Abruzzo e del Molise "G. Caporale", Campo Boario, 64100 Teramo (Italy), phone: 0039.0861.3321, fax: 0039.0861.332251

e-mail: c.ippoliti@izs.it, s.tora@izs.it, r.salini@izs.it, a.conte@izs.it, c.giansante@izs.it

²ARTA Abruzzo, Viale G. Marconi 178, 65127 Pescara (Italy),

e-mail: c.giansante@artaabruzzo.it, e.scamosci@artaabruzzo.it, m.petrini@artaabruzzo.it, n.dideo@artaabruzzo.it

³Istituto Superiore per la Protezione e la Ricerca Ambientale, Via Vitaliano Brancati 48, 00144 Roma (Italy), e-mail: federico.filipponi@isprambiente.it

Abstract – The Sentinel-2 mission is a constellation of two satellites, developed by ESA on behalf of the joint ESA/European Commission initiative GMES (Global Monitoring for Environment and Security). In addition to monitoring land cover and disasters, it is useful in the assessment of the quality of terrestrial and marine waters with biophysical and chemical-physical parameters such as chlorophyll "a" and total suspended matter concentrations. The twin Sentinel-2A and Sentinel-2B satellites are equipped with a MSI (MultiSpectral Instrument) optical sensor that acquires in 13 spectral bands, with global coverage, a revisit time of 5 days and a spatial resolution of up to 10 meters on the ground.

In this study, the estimates of chlorophyll "a" and of dispersion of sediments in the sea, derived from Sentinel-2 images were compared with in situ data acquired by means of a multiparametric probe in the monitoring stations that ARTA Abruzzo monthly checks along the Adriatic coast. The ultimate goal is to optimize parameters and algorithms to be able to derive concentration maps of chlorophyll and suspended solids from satellite, taking advantage of the high frequency of revisit time and high spatial resolution of the satellite acquisitions. This information is particularly relevant for aquaculture activities, for the monitoring of water quality and for the analyses of sedimentary processes.

Sentinel-2 level 1C images were processed using the C2RCC (Case-2 Regional Coast Colour) processor in ESA SNAP software, setting the required parameters of the algorithm according to the in situ sampling measurements, in 4 acquisition dates during the year 2018.

The comparisons, both at the sampling point and in the 100 meters radius buffer, showed statistically significant results: for chlorophyll "a", linear regression models have $r^2 = 0.82$ in situ, $r^2 = 0.81$ in the 100 m buffer, respectively; $r^2 = 0.88$ in situ and $r^2 = 0.91$ for TSM.

This preliminary study has provided encouraging results with only four sampling dates. In future ongoing work, the increase in the number of sampling dates should further improve the accuracy of the estimates; we aim also to compare other satellite products (e.g. Sentinel-3 OLCI) and test other algorithms (ACOLITE, BOMBER, etc.). All these aspects should lead to obtain a most accurate regional algorithm and an efficient process, for the production of maps and indicators useful in the monitoring of water quality.

Introduzione

Il monitoraggio delle acque costiere è richiesto da direttive europee [7, 8, 9, 23] e da regolamenti nazionali sulle attività produttive nelle aree litoranee: impianti di trattamento delle acque, attività di estrazione (ad es. petrolio e gas), acquacoltura, etc. Il raggiungimento del “buono” stato di qualità dell'ambiente marino è quindi un obiettivo comunitario e nazionale, parte della strategia di salute globale “One Health”, condizionata dalle attività antropiche e da cambiamenti climatici.

La necessità di dati sulla qualità delle acque (in senso lato) è stata finora soddisfatta principalmente tramite campionamenti e misurazioni di parametri chimico-fisici effettuati in mare [22]. Questo rende le campagne di acquisizione dati onerose in termini di risorse impiegate e permette campionamenti limitati nel tempo e nello spazio, mentre normalmente le aree marine da monitorare sono ampie ed è necessario un monitoraggio costante e frequente. Campagne di campionamenti e sistemi di monitoraggio per la qualità dell'acqua e la salubrità dei prodotti ittici in aree costiere sono utilizzati in acquacoltura [11, 24, 25], nel trattamento delle acque reflue, nelle attività di dragaggio, nella protezione delle Aree Marine protette, in tutte le attività commerciali e turistiche che insistono e convivono sulle zone costiere [10, 21]. I parametri rilevati e misurati, comuni a queste finalità, sono, principalmente, clorofilla “a”, trasparenza delle acque, torbidità, eventuale presenza di bloom algali e solidi sospesi.

Inoltre, l'Osservazione della Terra è una delle principali conquiste scientifico-tecnologiche degli ultimi decenni, poiché fornisce dense serie temporali di dati (con passaggi frequenti dei satelliti) su vaste aree geografiche (*big swath*, ossia grande superficie acquisita a terra) rilevando la radiazione riflessa dalle superfici in ampi intervalli dello spettro elettromagnetico.

Molti sono i prodotti di remote sensing dedicati al monitoraggio delle acque marine (es. *Copernicus Marine Environment Monitoring Service* - CMEMS, MODIS, Sentinel-3 OLCI). La loro media risoluzione spaziale (dimensione a terra della porzione di territorio rappresentata da un pixel) varia generalmente da 300 metri a 1 km, o dimensioni maggiori. Sebbene i sensori multispettrali a media risoluzione spaziale montati sulle piattaforme satellitari abbiano una configurazione radiometrica più adatta alla stima di parametri descrittivi della colonna d'acqua (es. Chl-a e TSM), la loro risoluzione spaziale rende difficilmente utilizzabile i loro prodotti in applicazioni di monitoraggio in prossimità delle coste, per le quali si rende necessaria l'identificazione di pattern spaziali anche a piccola scala.

I satelliti Sentinel, realizzati nell'ambito del programma comunitario Copernicus [20], contribuiscono al sistema globale di monitoraggio per l'osservazione della Terra (*Global Earth Observation System of System* - GEOSS); il programma è coordinato dalla Commissione Europea con la partecipazione dell'Agenzia Spaziale Europea (ESA). L'operatività è assicurata da un insieme di sei missioni (da Sentinel-1 a Sentinel-6) ciascuna dedicata a specifiche applicazioni. I satelliti Sentinel-2, nello specifico, oltre al monitoraggio della copertura del suolo e dei disastri, acquisiscono in prossimità della costa e possono essere impiegate per il monitoraggio delle acque terrestri e marine e per la mappatura delle variabili chimico-fisiche [16, 26], come la clorofilla “a” [24] e le concentrazioni di solidi sospesi totali (TSM) [2, 4, 5].

In questo studio, i parametri caratterizzanti la colonna d'acqua, clorofilla “a” e solidi sospesi totali, sono stati stimati da immagini Sentinel-2 MSI ed è stata confrontata

con dati *in situ* acquisiti in mare da sonda multiparametrica, lungo la costa abruzzese nel Mare Adriatico. L'obiettivo finale è quello di ottimizzare parametri ed algoritmi per poter derivare mappe di concentrazione di clorofilla "a" e solidi sospesi da satellite, sfruttando la loro elevata frequenza temporale e l'alta risoluzione spaziale. La generazione di tali informazioni potrebbe essere di rilevante supporto all'attività di acquacoltura, per il monitoraggio della qualità delle acque e per l'analisi dei processi sedimentari.

Materiali e Metodi

Area di studio

L'area di studio è lo specchio di Mare Adriatico prospiciente le coste della Regione Abruzzo. In questo tratto, lungo circa 120 km, si versano numerosi corsi d'acqua nelle cui pianure alluvionali di fondovalle sono presenti molte delle principali zone industriali ed agricole della regione. Le dinamiche di dispersione nel Mar Adriatico sono influenzate dalle correnti, dalle acque provenienti dal Mar Ionio, dalla portata del fiume Po e soprattutto dalla piovosità che provoca il maggior apporto di inquinanti in mare [6].

Dati rilevati in mare

Il piano di monitoraggio istituzionale che l'ARTA Abruzzo conduce sul controllo delle acque marino-costiere, è espletato sulla rete regionale, come indicato dalla convenzione con il Settore Opere Marittime della Regione Abruzzo, su 14 stazioni di campionamento distribuite su 7 transetti perpendicolari alla costa, ai fini della determinazione dello stato di qualità ambientale dei corpi idrici superficiali come previsto dal Direttiva 2000/60/CE. In ciascuna stazione sono state effettuate rilevazioni chimico-fisiche sulla colonna d'acqua: temperatura, salinità, conduttività, clorofilla "a", torbidità, ossigeno disciolto e pH.

Questi dati sono stati rilevati tramite sonda multiparametrica IDRONAUT Ocean Seven 316 Plus equipaggiata con fluorimetro e torbidimetro Seapoint Sensors, inc.

Dati satellitari

Le concentrazioni di clorofilla (CHL) e di solidi sospesi totali (TSM) in superficie, misurati *in situ*, sono state appaiate a stime derivate dalle misure radiometriche degli strumenti a bordo dei satelliti.

Il dataset di immagini satellitari utilizzati è quello della missione Copernicus Sentinel-2, con i due satelliti gemelli, Sentinel-2A e Sentinel-2B, che assicurano dati con tempi di rivisitazione (sullo stesso punto) e copertura globale di 5 giorni (ciascun satellite ripassa sullo stesso punto ogni 10 giorni) [16]. Questi satelliti sono dotati di un sensore ottico MSI (*MultiSpectral Instrument*) che acquisisce in 13 bande spettrali, tra i 443 nm e i 2190 nm, con una risoluzione spaziale tra 10 e 60 metri al suolo.

Per ciascun prelievo in mare è stato acquisito il passaggio dei satelliti Sentinel-2A o Sentinel-2B avvenuti lo stesso giorno (con una tolleranza di qualche ora tra il passaggio del satellite e la misurazione in mare) e senza copertura nuvolosa.

Processamento dei dati satellitari

I dati Sentinel-2 MSI sono stati elaborati in tre fasi: acquisizione, elaborazione e analisi statistica.

L'acquisizione è avvenuta tramite un batch script Python che sfrutta, previa registrazione, il servizio Copernicus Open Access Hub [18], grazie al pacchetto ufficiale SentinelSat, che scarica il dato Sentinel-2 nel formato compresso SAFE (*Standard Archive Format for Europe*).

I dati presi in esame (livello 1C) ricadono nelle granule T33TVG e T33TVH della griglia di distribuzione, appartenenti alle orbite 79 e 122 dei satelliti.

Il livello 1C fornisce immagini ortorettificate di dimensione 100 km x 100 km, nella proiezione *Universal Transverse Mercator/World Geodetic System 1984* (UTM/WGS84) e contiene la riflettanza Top of Atmosphere, ossia non corretto dall'effetto dell'atmosfera.

La fase di elaborazione, effettuata con il software SNAP v 6.0, distribuito da ESA, ha previsto il ricampionamento (o *resampling*) di tutte le bande alla risoluzione spaziale di 10 m, e l'estrazione delle bande dedicate di clorofilla "a" e solidi sospesi, prodotte dal processore di colori oceanici multi-missione C2RCC S2-MSI (Case-2 *Regional CoastColor*) [3], specifico per le Sentinel-2 e risultato tra i migliori stimatori di questi parametri in studi simili [1, 17]. È stato utilizzato l'algoritmo C2RCC-Nets, parametrizzato con i valori di salinità e temperatura ottenuti dai campionamenti *in situ* (tabella 1), e dalla pressione atmosferica relativa all'Aeroporto di Pescara [19] ricalcolata all'altezza del livello del mare. Dalle bande ottenute di *Chlorophyll concentration* (conc_chl) e *total suspended matter dry weight concentration* (conc_tsm), sono stati estratti sia i valori nelle stazioni di campionamento, sia la media dei valori in un buffer di 100 metri di raggio intorno a ciascuna stazione, per ciascuna data di acquisizione. Per questa elaborazione è stato utilizzato il software ESRI® ArcMap 10.5.

Sui dati estratti sono state effettuate analisi di regressione lineare per verificare l'esistenza di una relazione tra il valore dei parametri CHL e TSM stimati da rilevazioni satellitari e i valori degli stessi parametri campionati in mare. L'analisi statistica è stata effettuata mediante l'utilizzo del software R Core Team (2019).

Risultati

La figura 1 mostra la localizzazione delle 14 stazioni di campionamento dislocate lungo la costa abruzzese del Mar Adriatico, e sovrapposte, le delimitazioni delle immagini Sentinel-2A e Sentinel-2B (granule T33TVG e T33TVH).

Considerate le date di campionamento ed i passaggi dei due satelliti, sono state processate 4 immagini satellitari in 4 diverse giornate di campionamento in mare, per un totale di 18 osservazioni in 12 punti (Tabella 1). Tre osservazioni sono state escluse dalle regressioni poiché outlier nel dataset. Inoltre, per tener conto dei potenziali minimi scostamenti delle coordinate dei punti di campionamento, della sovrapposizione delle granule e della variabilità locale dei parametri misurati, è stato considerato sia il valore nel punto sia la media dei pixel in un intorno di 100 metri di raggio attorno a ciascun punto.

Ai dati estratti dall'elaborazione delle immagini satellitari, sia nel punto di campionamento, sia nel suo intorno di 100 metri di raggio, è stato applicato un modello di regressione lineare, che ha evidenziato risultati statisticamente significativi sia per la CHL ($r^2 = 0,82$ nel punto, figura 2; $r^2 = 0,81$ nel buffer di 100 metri, figura 3) sia per i TSM ($r^2 = 0,88$ nel punto figura 4, $r^2 = 0,91$, figura 5).

Applicando tali regressioni (media nel buffer a 100 metri) alle quattro immagini considerate, sono state ottenute le mappe di CHL (Figura 6) e TSM (Figura 7).



Figura 1 - Localizzazione dell'area di studio e delle stazioni di campionamento. I riquadri mostrano l'extent delle immagini satellitari acquisite dai sensori a bordo dei satelliti Sentinel-2A e Sentinel-2B.

Figure 1 - Study area (coast facing Abruzzo region in the Adriatic Sea) and location of the sampling points. The squares are the extent of satellite imagery of Sentinel-2A e Sentinel-2B.

Tabella 1 - Campionamento *in situ*: date, stazioni di campionamento e misure rilevate, utilizzate come parametri del modello.

Table 1 - *In situ* sampling: dates, sampling points and *in situ* collected values used in the models.

Data di campionamento	Stazioni di campionamento	Salinità media (PSU)	Temperatura media (°C)	Pressione atmosferica (hPa)	Satellite corrispondente
03-01-2018	OR07, OR09, VA10, VA12, SS01, SS02	36,5	9,2	1016,5	Sentinel-2A
09-03-2018	PI16, PI18	32,3	9,3	1019,5	Sentinel-2B
20-06-2018	OR07, OR09, VA10, VA12, SS01, SS02	35,2	24,8	1020,5	Sentinel-2B
12-07-2018	AL13, AL15, GU01, GU03	34,8	27,1	1016,5	Sentinel-2A



Figura 2 - Modello di regressione lineare tra dati campionati in mare (*in situ*) e le concentrazioni di clorofilla stimate a partire dai dati satellitari (Satellite) sul punto di campionamento (mg/m^3).

Figure 2 - Linear regression model between sampling collected in the sea (in situ) and the estimated concentration in the same point of chlorophyll "a" derived from satellite imagery (Satellite) (mg/m^3).

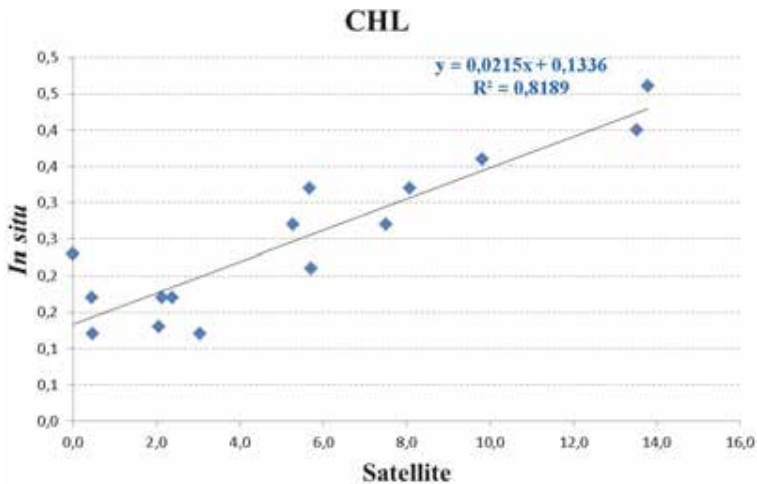

Figura 3 - Modello di regressione lineare tra dati campionati in mare (*in situ*) e le concentrazioni di clorofilla stimate a partire dai dati satellitari (Satellite 100 m) nell'intorno di 100 m dal punto di campionamento (mg/m^3).

Figure 3 - Linear regression model between sampling collected in the sea (in situ) and the average estimated concentration in a 100 m - buffer around the point of chlorophyll "a" derived from satellite imagery (Satellite) (mg/m^3).

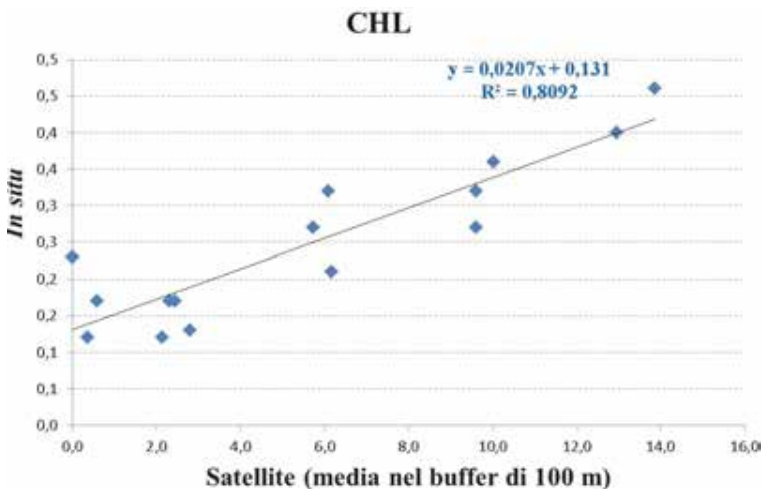

Figura 4 - Modello di regressione lineare tra dati campionati in mare (*in situ*) con fluorimetro (in FTU) e le concentrazioni di solidi sospesi stimate con l'algoritmo C2RCC dai dati satellitari (Satellite) sul punto di campionamento (in g/m³).

Figure 4 - Linear regression model between sampling collected in the sea (in situ) measured with a fluorimeter (in FTU) and the concentration in the same point of Total Suspended Matter (TSM) estimated with the C2RCC algorithm from satellite imagery (Satellite) (in g/m³).

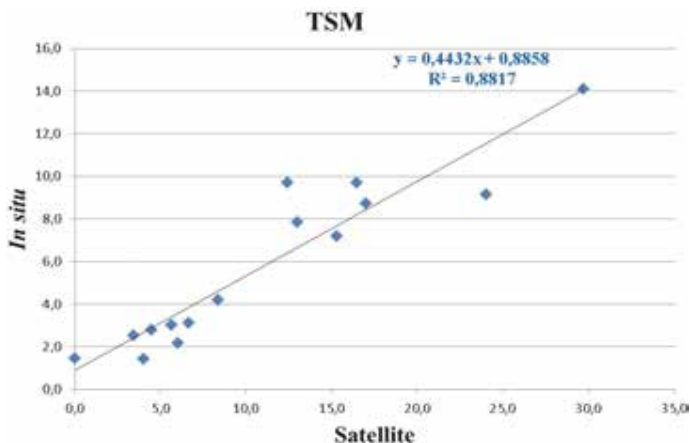

Figura 5 - Modello di regressione lineare tra dati campionati in mare (*in situ*) con fluorimetro (in FTU) e le concentrazioni di solidi sospesi stimate con l'algoritmo C2RCC dai dati satellitari (Satellite 100 m) nell'intorno di 100 m dal punto di campionamento (in g/m³).

Figure 5 - Linear regression model between sampling collected in the sea (in situ) measured with a fluorimeter (in FTU) and the average concentration in a 100 m-buffer around the point of Total Suspended Matter (TSM) estimated with the C2RCC algorithm from satellite imagery (Satellite 100 m) (in g/m³).

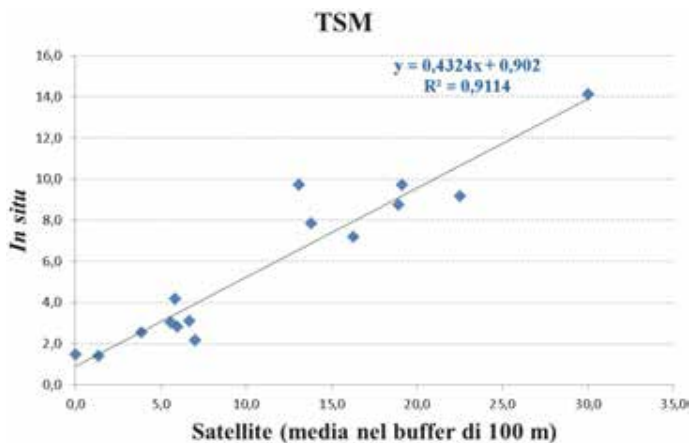

Figura 7 - Mappe di concentrazione dei sedimenti di solidi sospesi (TSM) della costa abruzzese elaborate dalle immagini Sentinel-2 con il processore C2RCC per le date 03/01, 09/03, 20/06 e 12/07 del 2018 con i punti di campionamento *in situ*, corrispondenti alle granule T33TVG e T33TVH.

Figure 7 - Concentration maps of Total Suspended Matter (TSM) along Abruzzo coast in the Adriatic sea, as elaborated with the C2RCC processor from Sentinel-2 imagery of the dates: 03/01/2018, 09/03/2018, 20/06/2018 and 12/07/2018. The values in the maps are obtained by applying the linear regression in the 100 m – buffer (figure 5). The images on the left side are the T33TVG granule, the images on the right are the T33TVH granule.

di calibrazione), in grado di correggere effetti relativi alle condizioni presenti al momento dell'acquisizione delle immagini (es. *sun-glint*) e capace di produrre mappe ed indicatori per il monitoraggio della qualità delle acque.

Le unità di misura non sono sempre corrispondenti, dato che generalmente le misure *in situ* per la caratterizzazione della qualità delle acque vengono fatte con strumenti che misurano fluorescenza e torbidità, mentre gli algoritmi da satellite stimano Chl e TSM. Campagne *ad hoc* saranno necessarie per misurare *in situ* il dato da torbidimetro, e contestualmente effettuare prelievi di acque superficiali da analizzare poi in laboratorio. Così facendo avremo la possibilità di confrontare il dato satellitare con quello reale utilizzando la stessa unità di misura prevista dai metodi analitici per le acque.

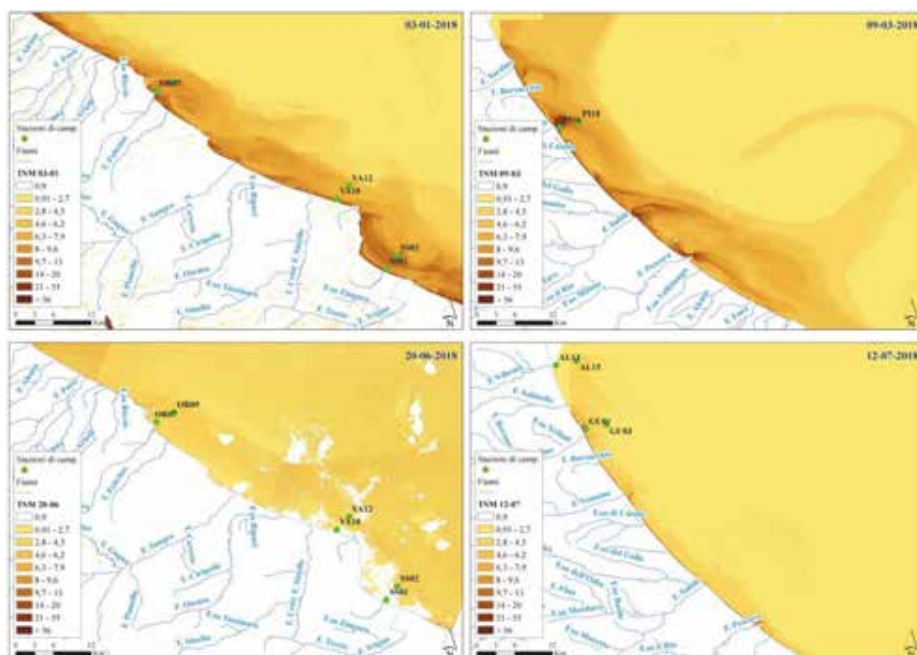
L'obiettivo è di regionalizzare gli algoritmi di stima per le acque della costa abruzzese, con risultati coerenti e affidabili, che potranno in futuro essere utilizzati per ottimizzare gli strumenti di monitoraggio riducendo anche l'impiego delle risorse in mare.

A regime si potranno avere mappe multitemporali di clorofilla “a” e solidi sospesi totali su vaste porzioni di superfici [22], finalizzati al monitoraggio dei loro pattern spaziali di distribuzione [14, 13]. La rilevanza nell’utilizzo dei dati Sentinel-2 è data dalla risoluzione spaziale (10 metri), compatibile con la scala di osservazione necessaria alla valutazione e al monitoraggio degli effetti nel mare delle attività antropiche.

Ringraziamenti

Il presente lavoro è stato finanziato dalla Regione Abruzzo, Dipartimento Politiche Dello Sviluppo Rurale E Della Pesca, nell’ambito della convenzione 2019/2020 denominata SATSEA con fondi misura 2.51 del PO FEAMP 2014/2020.

Bibliografia

- [1] Ansper A., Alikas K. (2019) - *Retrieval of Chlorophyll a from Sentinel-2 MSI Data for the European Union Water Framework Directive Reporting Purposes*. Remote Sens. 2019, 11, 64. <https://doi.org/10.3390/rs11010064>
- [2] Bowers D., Braithwaite K., Nimmo-Smith W., Graham G. (2009) - *Light scattering by particles suspended in the sea: The role of particle size and density*. Cont. Shelf Res. 2009 29 1748–1755.
- [3] Brockmann, C., Doerffer, R., Peters, M., Stelzer, K., Embacher, S., Ruescas, A. (2016) - *Evolution of the C2RCC neural network for Sentinel 2 and 3 for the retrieval of ocean colour products in normal and extreme optically complex waters*. In Proceedings of the Living Planet Symposium, Prague, Czech Republic, 9–13 May 2016.
- [4] Caballero I., Steinmetz F., Navarro G. (2018) - *Evaluation of the First Year of Operational Sentinel-2A Data for Retrieval of Suspended Solids in Medium- to High-Turbidity Waters*. Remote Sens. 2018, 10, 982. <https://doi.org/10.3390/rs10070982> .
- [5] Caballero I., Stumpf R.P. (2020) - *Towards Routine Mapping of Shallow Bathymetry in Environments with Variable Turbidity: Contribution of Sentinel-2A/B Satellites Mission*. Remote Sens. 2020, 12, 451.
- [6] Colaiuda V., Di Giacinto F., Lombardi A., Ippoliti C., Giansante C., Latini M., Mascilongo G., Ludovica Di Renzo L., Berti M., Conte A., Ferri N., Verdecchia M., Tomassetti B. *Evaluating the impact of hydrometeorological conditions on E. coli concentration in farmed mussels and clams: a case study in Central Italy*. In preparation.
- [7] DIRETTIVA 2000/60/CE DEL PARLAMENTO EUROPEO E DEL CONSIGLIO del 23 ottobre 2000 che istituisce un quadro per l'azione comunitaria in materia di acque (GU L 327 del 22.12.2000)
- [8] DIRETTIVA 2006/7/CE DEL PARLAMENTO EUROPEO E DEL CONSIGLIO del 15 febbraio 2006 relativa alla gestione della qualità delle acque di balneazione e che abroga la Direttiva 76/160/CEE) (GU L 64 del 04.03.2006)
- [9] DIRETTIVA 2008/56/CE DEL PARLAMENTO EUROPEO E DEL CONSIGLIO del 17 giugno 2008 che istituisce un quadro per l'azione comunitaria nel campo della politica per l'ambiente marino (Direttiva quadro sulla strategia per l'ambiente marino) (GU L 164 del 26.06.2008)

- [10] Douvère F. (2008) - *The importance of marine spatial planning in advancing ecosystem-based sea use management*. Mar Policy 32:762-71.
- [11] Ferrè N., Mulatti P., Mazzucato M., Lorenzetto M., Trolese M., Pandolfo D., Vio P., Sitta G., Marangon S. (2011) - *GeoCREV: veterinary geographical information system and the development of a practical sub-national spatial data infrastructure*. Geospat Health 5:275-83.
- [12] Filippini F., Bassani C., Taramelli A., (2015) - *Comparison of Sentinel-3 OLCI simulated data with MERIS for Ocean Color parameter estimation*. Proceedings of "Sentinel-3 for Science Workshop", Venice (Italy) 2-5 June 2015, ESA SP-734 (CD-ROM). ISBN: 978-92-9221-298-8.
- [13] Filippini F., Zucca F., Taramelli A., Valentini E., (2015) - *Total Suspended Matter (TSM) and maximum signal depth (Z90_max) for monitoring the evolution of sediment resuspension processes in shallow coastal environments*. Proceedings of "Sentinel-3 for Science Workshop", Venice (Italy) 2-5 June 2015, ESA SP-734 (CD-ROM). ISBN: 978-92-9221-298-8.
- [14] Filippini F., Taramelli A., Zucca F., Valentini E., El Serafy G.Y., (2015) - *Ten years sediment dynamics in northern Adriatic Sea investigated through optical Remote Sensing observations*. International Geoscience and Remote Sensing Symposium (IGARSS), 2015 IEEE International, pp. 2265-2268. ISBN: 978-1-4799-7929-5. <https://doi.org/10.1109/IGARSS.2015.7326258>
- [15] Filippini F., (2018) *River Color Monitoring Using Optical Satellite Data*. Proceedings, 2(10), 569. https://doi.org/10.3390/IECG_2018-05336
- [16] Gascon F., Bouzinac C., Thépaut O., Jung M., Francesconi B., Louis J., Lonjou V., Lafrance B., Massera S., Gaudel-Vacresse A., Languille F., Alhammoud B., Viallefont F., Pflug B., Bieniarz J., Clerc S., Pessiot L., Trémas T., Cadau E., De Bonis R., Isola C., Martimort P., Fernandez V. (2017) - *Copernicus Sentinel-2A Calibration and Products Validation Status*, Remote Sens.2017, 9, 584. <https://doi.org/10.3390/rs9060584> .
- [17] Hafeez S. and Wong M. S. (2019) - *Measurement of Coastal Water Quality Indicators Using Sentinel-2, An Evaluation Over Hong Kong and the Pearl River Estuary*. IGARSS 2019 - 2019 IEEE International Geoscience and Remote Sensing Symposium Yokohama Japan 2019 pp. 8249-8252 <https://doi.org/10.1109/IGARSS.2019.8899342> .
- [18] <https://scihub.copernicus.eu/>
- [19] <https://weatherspark.com/>
- [20] <https://www.copernicus.eu/en>
- [21] Ippoliti C., Di Lorenzo A., Caprioli R., Pelini S., Conte A., D'Anselmo F., Alessandrini B., Tora S., Giansante C. (2018) - *SeaGIS Abruzzo: A publicly available atlas of marine uses and natural resources in the Adriatic Sea Region*. Geospatial Health 13. <https://doi.org/10.4081/gh.2018.705>.
- [22] Ouellette W., Getinet W. (2016) - *Remote sensing for Marine Spatial Planning and Integrated Coastal Areas Management: Achievements challenges opportunities and future prospects* Remote Sensing Applications: Society and Environment Volume 4 2016 Pages 138-157 ISSN 2352-9385, <https://doi.org/10.1016/j.rsase.2016.07.003> .
- [23] RACCOMANDAZIONE DEL PARLAMENTO EUROPEO E DEL CONSIGLIO del 30 maggio 2002 relativa all'attuazione della gestione integrata delle zone costiere in Europa (2002/413/CE) (GU L 148 del 06.06.20028)

- [24] Soriano-González J., Angelats E., Fernández-Tejedor M., Diogene J., Alcaraz C. (2019) - *First Results of Phytoplankton Spatial Dynamics in Two NW-Mediterranean Bays from Chlorophyll-a Estimates Using Sentinel 2: Potential Implications for Aquaculture* Remote Sens. 2019, 11, 1756.
- [25] Tora S., Sacchini S., Listeš E., Bogdanović T., Di Lorenzo A., Smajlović M., Smajlović A., Filipović J. V., Tahirović V., Šuković D., Beljkas B., Xinxo A., Maçi R., Colangeli P., Di Giacinto F. & Conte A. (2017) - *A geographical information system for the management of the aquaculture data in the Adriatic Sea – the Strengthening of Centres for Aquaculture Production and Safety surveillance in the Adriatic countries experience: Present capabilities, tools and functions*. Geospatial Health 12(2). <https://doi.org/10.4081/gh.2017.593> .
- [26] Traganos D., Reinartz P. (2018) - *Mapping Mediterranean seagrasses with Sentinel-2 imagery*. Marine Pollution Bulletin Volume 134 2018 Pages 197-209 ISSN 0025-326X <https://doi.org/10.1016/j.marpolbul.2017.06.075> .

MÉTIERS, EFFORT AND CATCHES OF A MEDITERRANEAN SMALL-SCALE COASTAL FISHERY: THE CASE OF THE GULF OF LION MARINE NATURAL PARK

Maxence Morel¹, Blandine Lapierre¹, Alice Goossens¹, Eva Dieudonné¹, Philippe Lenfant¹, Lauriane Vasseur², Virginie Hartmann³, Marion Verdoit-Jarraya^{1*}

¹Université de Perpignan Via Domitia, CNRS, Centre de Formation et de Recherche sur les Environnements Méditerranéens, UMR 5110, 52 avenue Paul Alduy - F-66860 Perpignan (France),

*Corresponding author: e-mail: marion.jarraya@univ-perp.fr

²Office Français de la Biodiversité, Parc naturel marin du Golfe du Lion, 2 Impasse Charlemagne - 66700 Argelès-sur-Mer (France),

³Département des Pyrénées-Orientales, Réserve Naturelle Marine de Cerbère-Banyuls, 5 rue Roger David - 66650 Banyuls-sur-Mer (France)

Abstract – Littoral ecosystems are under a variety of threats including overexploitation of fishery resources which has led to a major fisheries crisis. In this context, Marine Protected Areas (MPA) have been established around the world to counter the overuse of these ecosystems and serve notably as management tools for the fisheries. Within MPAs, policymakers along with scientists need data to decide on the implementation of new measures, to estimate their effects and to adapt their management accordingly. The objectives of this study were to describe at a spatio-temporal scale, the characteristics of the Small-Scale Fisheries (SSF) in the Gulf of Lion Marine Natural Park (GLMNP), an MPA located in north-west Mediterranean. Common tools such as fishing effort, Catch Per Unit Effort (CPUE) and “métiers”, defined by the use of a fishing gear with a targeted species, were used. A field protocol was implemented to collect data through questionnaires to fishers at landing sites during a study period of one-year between April 2019 and March 2020 within the GLMNP. A total of 35 fishers (67 % of the active fishers) from the 7 fishing harbours responded to our questionnaire and 167 trips on fishing ports have been realized. During these trips, 5219 days of fishing activity or inactivity and 510 fishing operations were collected from the SSF fleet within the GLMNP. The most frequently used métiers were the hake gill net and the sparids trammel net and gill net, targeting two predominant species: hake (*Merluccius merluccius*) and gilthead seabream (*Sparus aurata*). The spatial distribution of the fishing operations seemed to depend on the proximity to the harbour, on the knowledge and habits of the fishermen and also on a spatial competition that may occur among fishers targeting the same species or group. The methodology used in this study is part of a long term monitoring requiring close collaboration with local fishers. It is expected to enable adaptive management to contribute to the sustainability of SSF notably through measures related to fishing pressure which may impact the environment and its resources.

Introduction

Fisheries across the world remain for millions of people, a vital activity, providing various ecosystems services (e.g. food and cultural services such as recreational and artisanal

fishing) [8, 24]. The industrialization of the 20th century has favored the increase in the number of boats as well as their power and the emergence of new technologies such as the Satellite Positioning System (GPS) or the echo-sounder. Especially in the Mediterranean, and mostly for the Large-Scale Fishing sector (LSF), these innovations have greatly contributed to the increase in fishing pressure exerted on the habitats and species [13, 22]. Regarding the Small-Scale Fishery (SSF) (or artisanal fishery), it includes boats not exceeding twelve meters and operating onshore for trips of less than 24 hours [5, 7, 11, 26].

This sector is undergoing a serious crisis in Europe because of compete for resources and space with many emergent activities such as tourism, exploitation of fossil and renewable energies and transport [11,18]. In the Mediterranean, 72 % of the EU fleet belongs to SSF with a total of 34 976 active vessels accounting to about 70 000 jobs. Regarding landings and effort, LSF contributes respectively to 89 % of the total weight (78 % by value) and 36 % of the effort. The SSF represents 11 % of the total landed-weight (22 % of the landed value) and deployed 64 % of the effort [23]. Despite this low amount of landings and the decrease of its importance for the EU's fleet in the northern Mediterranean, the SSF sector is of high cultural and socio-economic importance and is well anchored in Mediterranean countries [17]. The SSF maximizes the economic value of the diversity of resources it exploits by selling their products at higher prices compared to the LSF. Moreover, the products are mainly destined to tourist markets or local markets (either in fish stalls, or to the restaurants) [3, 11, 23]. The artisanal fishery is characterized by the use of numerous fishing gears (gill nets, trammel nets, longline, pots, basket traps) targeting a wide range of species. The term "métier", or fishing tactics, is used to define the combination of a fishing gear with a targeted species in a given season. The use of these "métiers" may also change according to the seasonal dynamics of the resources [4, 17, 26]. This approach of the fishing tactics is likely to be useful to understand the spatio-temporal patterns of the fishing effort allocation and related catches [14, 26]. Due to the diversity of tactics used and the high selectivity of the target species, thus allowing much less discards, the SSF appears to be a relatively sustainable modes of exploitation of coastal resources in comparison with the LSF such as trawling. Nevertheless, it is difficult to accurately evaluate these fisheries because of the large number of fishers located in multiple harbours [15, 16, 20]. Due to the development of maritime transport, tourism and urbanization, artisanal fisheries must face increasing constraints in order to maintain their activity. Thus, the Common Fisheries Policy in Europe raises the matter of taking greater account of the SSF [6, 11] and requires integrating ecological, technological and socio-economic approaches to the study of fisheries [1, 17]. The SSF remains poorly evaluated and compared in the Mediterranean, and particularly on the scale of an MPA. The latter are however recognized as tools for managing these fisheries via the spillover effect [7] notably resulting from the implementation of several measures such as fishing effort limitations, minimum catch size or seasonal closure. In view of the growing challenge of sharing space (renewable marine energies, extractions, submarine cables, leisure and professional fisheries, etc..), managers of the Gulf of Lion Marine Natural Park (GLMNP), located in northern Mediterranean, aim at supporting the implementation of a long term management plan for the sustainability of the SSF. For this purpose, many surveys of this activity were implemented particularly in collaboration with researchers from the CEFREM laboratory since 2007.

The objectives of this study, through the "PêchePro" project, were to determine spatio-temporal characteristics of the SSF using landing data on a year round survey. Firstly,

the main technical characteristics of the SSF were described in the various harbours. Secondly, catches and métiers were described and spatialized using fishing effort and Capture Per Unit of Effort (CPUE). The latter being a commonly used measure for comparing regional and temporal trends by providing an estimate of the abundance of a fish stock and also serve as an indicator for the impact of the SSF activity on resources [19,27]. Thirdly, comparison and evolution of CPUE and fishing effort between 2012 and 2020 by métier were realized.

Materials and Methods

The GLMNP located in the gulf of Lion continental shelf, north-western Mediterranean Sea (42°40' North, 3°5' East) was established in 2011 (Fig. 1). This MPA of 4010 km² stretches over 100 km from Cap Leucate to the border with Spain at Cap Cerbère. It comprises the Marine Natural Reserve of Cerbère-Banyuls (MNRCB) established since 1974. The heterogeneous coastal shelf consists of 70 km of sandy coast in the north and 30 km of rocky coast in the south. This coastal area is the spillway of numerous rivers and it also communicates with two ponds through several “graus”. The bigger is the Salses-Leucate pond on the north that was included in the survey because of the mixt activities of the fishers between sea and pond. The SSF survey took place in the 7 main fishing harbours (Port-Leucate, Port-Barcarès, Canet-en-Roussillon, Saint-Cyprien, Argelès-sur-Mer, Port-Vendres and Banyuls-sur-mer). The GLMNP includes three “prud’homies” (local fisher’s guild) which manage and coordinate their attributed area and insure the communication with the GLMNP through meetings and steering committees. From different scales: (i) European Union, (ii) National and (iii) Local (Prud’homies), regulations are already enforced respectively through several measures within the GLMNP: (i) e.g. maximum fishing net length, (ii) e.g. minimum catch size and (iii) access regulation (mainly within the MNRCB) or number of pots and traps.

After having determined an actualized list of the active and non-active vessels and their main features through registries of the European fleet and maritime offices (engine power, gross tonnage, overall length), the SSF characteristics were generally collected by 2 persons during harbour trips. It encompassed the fishing technique, targeted species, net length and height, mesh size, soak time, location, depth, catch estimation and species total length and weight. Interviews with skippers (most often the vessel owner) were conducted about every day including weekends (excepted sunday) during the opening hours of the fishing stalls (8 am to 12 pm). In total, 35 of the 52 active fishers answered at least once to the survey during a one year period. The last third whether refused to answer to the interview or were not seen on harbours dock. Fishers working exclusively in the ponds were not included in the study. Field survey to collect landing and effort data in 6 harbours, Canet-en-Roussillon excluded, were realized depending on the weight of the fishing activity i.e. number of active boats. Between April 2019 and March 2020, a total of 510 interviews were conducted during 167 mornings spent on harbours. The questionnaire was related to the daily fishing trips and the use of one métier corresponded to one fishing operation (e.g. hake gill nets). Fishers drawn their operation’s location on a standard NHOS map (Naval Hydrographic and Océanographic Service) and all 510 operations were plotted into a

Geographical Information System (QGIS 3.6® software). Discards were rarely observed because fishers usually rejected them overboard on their way back to the fishing port.

According to previous studies, the catches of SSF were assumed to be equal with the landings because of the few discards. Discards included damaged specimens, species under the minimum catch size and species which could not be sold e.g. *genus Torpedo* [17]. Then, informations about substratums (sand, mud, rock) were collected using open access websites [12].

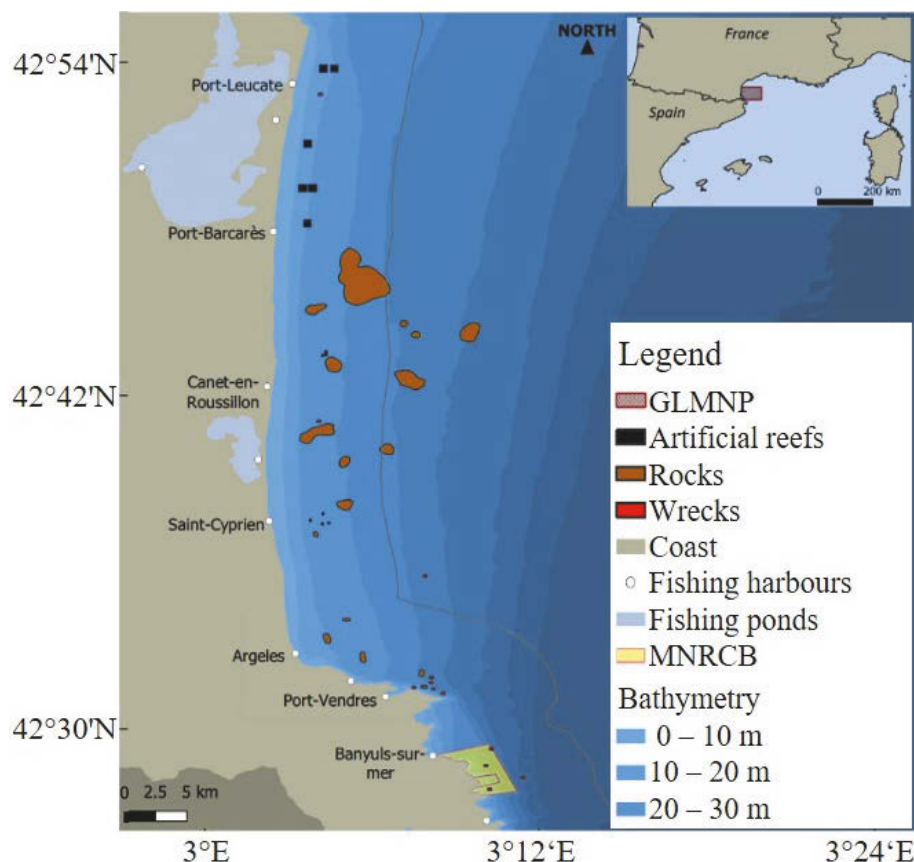

Figure 1 - Location and characteristics of the study area (Gulf of Lion Marine Natural Park) on the north-western Mediterranean and the main fishing harbours.

In this study, and in order to compare data with other study area throughout Mediterranean, different clusters (group of species) were defined according to the declared target species and comprised all the Fishing Operations (FO) related to that species or group targeted. The cluster “sparids” included métiers targeting *Sparus aurata* and *Pagellus*

erythrinus with gill net, trammel net and combined. The latter species was targeted with gill net with similar characteristics as the gilthead seabream' gill net in term of mesh size, net height and length. Flatfishes cluster corresponded to métiers targeting soles, turbot and brill as the turbot and brill were often targeted as secondary species or considered as associated catch [15]. Catch (or more precisely landings) per unit effort (CPUE) was expressed as the total volume of fish landed in kilogram per 100 meters of nets [15, 19, 27]. Statistical analyzes were performed on the data collected for the whole year using Excel® and Rstudio 3.5.1® software [21]. Fishing effort and CPUE between data collected in 2012 [2] and 2020 were analysed through non-parametric Wilcoxon Mann-Whitney test [28].

Results

During the study period, data pertaining to 45 boats, out of 67 active boats, were analysed. Average characteristics of the 78 active and inactive SSF vessels were $7,38 \pm 1,6$ meters' length, 31 ± 14 years, $2,51 \pm 1,99$ gross tonnage and $80,57 \pm 59,59$ kW. The most active fishing harbour was Port-Barcarès, followed by Port-Vendres and the less active that of Canet-en-Roussillon (Table 1).

Table 1 - Number of boats and technical characteristics of the Small Scale Fishery fleet in the 7 harbours within the Gulf of Lion Marine Natural Park in 2020. YOC: Year of Construction, LOA: Overall Length, HP: Horse Power, GRT: Gross Register Tonnage. sd: standard deviation.

Harbours	Active boats	Characteristics of all boats (mean \pm sd)			
		YOC	LOA	HP	GRT
Argelès/mer	3	1997 \pm 9,8	7,8 \pm 1,5	123, 3 \pm 75,7	3,8 \pm 1,5
Banyuls/mer	4	1982 \pm 19,6	7,6 \pm 2,3	74,8 \pm 67,7	3,1 \pm 3,5
Port-Barcarès	24	1988 \pm 15,3	6,7 \pm 1,3	70,4 \pm 64,8	1,5 \pm 1,1
Canet	2	1969 \pm 6,4	7,1 \pm 1,3	72 \pm 24	1,5 \pm 1,2
Leucate	12	1993 \pm 14,8	6,6 \pm 1	62,3 \pm 43,7	1,7 \pm 1,2
Port-Vendres	13	1982 \pm 10,2	8,4 \pm 1,9	90,8 \pm 44	3,2 \pm 2,7
Saint-Cyprien	9	1992 \pm 11,4	8,8 \pm 1,8	119,8 \pm 73,3	4 \pm 2,7

In total, 6 clusters were identified and corresponded to: sparids (138 fishing operations), hake (107), cuttlefish (46), red mullet (44), flatfishes (37) and monkfish (24). Except for the “sparids”, each métier used a single gear. Three métiers “hake”, “sparids” and “flatfishes” were used almost throughout the whole year (Table 2). The “red mullet” métier was mainly practiced during late spring-summer, while “cuttlefish” and “monkfish” were principally used during winter-spring. Relating to fishing ground, each métier was practiced in distinct habitats and depths. The “monkfish” and “hake” métiers were preferably performed above detritic muddy bottom (79 % and 86 % of the fishing net length). Flatfishes and red mullet were mainly targeted on detritic sand or detritic rock and coarse sediment (86 % and 80 % respectively), whereas cuttlefish were fished near-shore on sand or mud (76 %) and

the sparids were targeted on mixed substrates as well as in the ponds where it accounted for 37 % of the “sparids” métiers. Fishers using nets practiced an average of $1,4 \pm 0,61$ fishing operations, $1,3 \pm 0,57$ métiers and set an average of $1733,8 \pm 1209$ m per fishing trip. The “flatfishes” and “monkfish” métiers used the longest lengths of net per fishing operation although “red mullet” métier represented the shortest average length. The “hake” and “sparids” métiers had the largest CPUE in comparison with the “flatfishes”, “cuttlefish” and “red mullet” métiers which showed the lowest CPUE (Table 3).

Table 2 - The 6 main clusters are described through fishing period, number of boats practicing the métier and Fishing Operations (FO). Fishing period corresponds to the shading: no shading (< 5 % of fishing operations observed during the month); light shading ([5-10] %); dark shading (>10 %). Mean depth, net height, mesh size (non stretched) are also shown. sd: standard deviation.

Cluster/Métier	Fishing period		Boats	Characteristics (mean \pm sd)			
				FO (%)	Depth (m)	Net height (m) \pm sd	Mesh size (mm) \pm sd (range)
	2019	2020					
A M J J A S O N D J F M							
Cuttlefish			21	9	8 ± 5	$1,63 \pm 1,37$	$44,2 \pm 9,3$ (35÷100)
Flatfishes			15	7	23 ± 19	$1,43 \pm 0,27$	$59,5 \pm 24,8$ (35÷100)
Hake			18	21	46 ± 19	$6,7 \pm 5,45$	$32,6 \pm 1,8$ (31÷35)
Monkfish			11	5	67 ± 32	$1,59 \pm 0,81$	$83,3 \pm 16,4$ (45÷120)
Red mullet			13	9	19 ± 5	$1,33 \pm 0,31$	$22,1 \pm 3,8$ (16÷40)
Sparids			33	27	12 ± 12	$4,85 \pm 3,89$	$43,1 \pm 6,3$ (30÷75)

Fishing effort and CPUE were statistically compared among the 6 main clusters between 2012 and 2020 (Table 3). Results indicated that mean length of net per fishing operation were significantly higher in 2020 for 3 clusters only: “cuttlefish”, “sparids” and “all nets”. Concerning CPUE, the “hake” métier showed the most significant increase between 2012 and 2020 ($N = 184$, $W = 2232$, $p\text{-value} = 1,192e-7$: ***). The “all nets” cluster also displayed a significantly higher value in 2020 than in 2012 ($N = 937$, $W = 91494$, $p\text{-value} = 5,7e-3$: ***). For the 5 other métiers, no statistical differences were observed despite a slight decrease in yield for the “cuttlefish” and “sparids” métiers and a low increase for the “red mullet” métier.

Spatial distribution of the SSF using nets (465 fishing operations) generally occurred within the 3 nautical miles strip and were quite well distributed along the GLMNP coast and in the Salses-Leucate pond (Fig. 2). In the latter, CPUE were relatively low ($0,92 \pm 1,21$ kg 100 m $^{-1}$) compared with marine areas ($2,66 \pm 4,47$ kg 100 m $^{-1}$) and mean net lengths were generally higher 2251 ± 1363 m than those obtain at sea (1577 ± 1112 m). The CPUE seemed also higher on mixsubstrates at Cap Leucate in the north and between Argelès-

sur-mer and Banyuls-sur-mer in the south. Besides, a small proportion of the fishing activity occurred off-shore in the deep sea canyons but the CPUE did not seem to be higher than within the 3 nautical miles.

Table 3 - Statistical comparison (through Wilcoxon Mann-Whitney tests) and evolution of CPUE and fishing effort between 2012 and 2020 by métier in the Gulf of Lion Marine Natural Park. P-value and Mann-Whitney (W) value are also shown. Levels of significance were * $p \leq 0,05$; ** $p \leq 0,01$; *** $p \leq 0,001$.

Cluster	Fishing effort (m)		W, P-value	CPUE (kg·100 m ⁻¹)		W, P-value
	2020	2012		2020	2012	
Cuttle fish	1896	1461	786, 0,010 **	1,18	1,63	1286,0 0,24
	± 865	± 887		± 0,73	± 1,43	
Flatfishes	2757	2274	727, 0,88	0,97	0,82	823, 0,38
	± 1978	± 2292		± 0,8	± 0,63	
Hake	1739	1885	4461, 0,33	3,49	2,01	2232, 1,19e-07***
	± 807	± 898		± 2,51	± 1,61	
Monkfish	2563	2200	57, 0,88	1,72	1,88	71,0 0,56
	± 1349	± 570		± 1,07	± 0,76	
Red mullet	1102	1122	1429, 0,78	1,23	0,96	1220, 0,13
	± 335	± 541		± 0,97	± 0,8	
Sparids	1550	1115	6834, 2,9e-03 ***	2,33	2,52	8756, 0,89
	± 1230	± 1004		± 2,75	± 3,59	
All nets	1702	1393	81715, 1,3e-07 ***	2,14	2,09	91494, 5,7e-03 ***
	± 1162	± 1205		± 2,26	± 3,19	

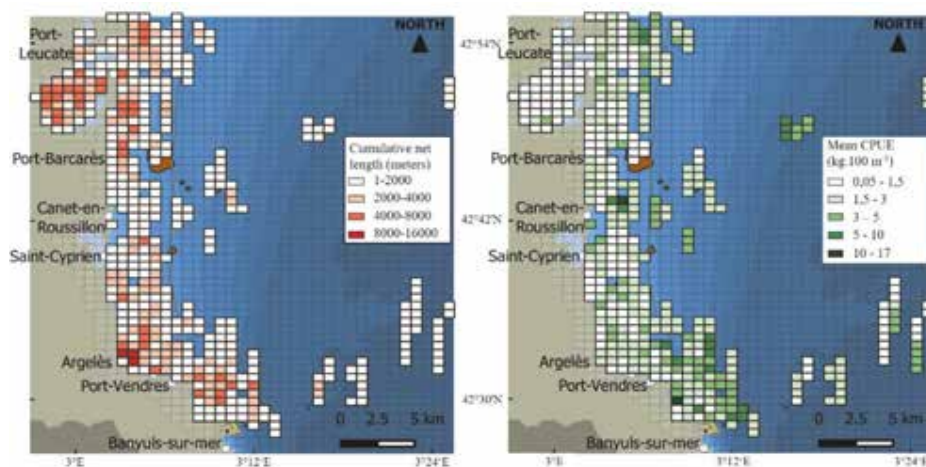

Figure 2 - Spatialisation of the fishing effort (cumulative net length in meters) and Catch Per Unit Effort (in kg·100 m⁻¹) for all fishing operations using net (gill net, trammel net and combined) within the Gulf of Lion Marine Natural Park. Brown spots correspond to the location of rocky plateaus.

Discussion

The Mediterranean artisanal fishing fleet within the GLMNP is typical because boats characteristics observed in this study are similar with those observed in other French Mediterranean areas [15], Spanish areas [7, 17] or in Italy [4]. The main fishing techniques were the trammel net and gill net even though pots and longline were used very frequently. The tuna longline and octopus pots and baskets were métiers well represented in our data (11 fishing operations, 2,2 %, and 24, 4,7 %, respectively). A total of 18 boats targeted octopus and 7 used tuna longline but both métier could not be analyzed in a consistent manner, despite the fact that they greatly contribute to the SSF economy within the GLMNP, because landings rarely occurred during the opening hours of stalls.

A particular emphasize should be done on the study of *Octopus vulgaris*, a species caught by several gears and considered as the second species of importance for the Spanish SSF [10]. Our results show that from the 38 métiers observed within our study zone, 6 targeted species (namely clusters) represented most of the fishing operations (78 %) and among these 6 clusters, 5 are well represented in other Mediterranean SSFs in terms of seasonality and occurrence (e.g. cuttlefish, flatfishes, hake, octopus, red mullet and sparids [4, 15, 17, 26]. Concerning catches, and except with clusters “hake” and “all net” for which mean CPUE increased significativly from 2012 to 2020 within the GLMNP, annual CPUE remained globally stable between the two study periods (Table 2) [2]. This would be in agreement with the study of García-Rodríguez and collaborators [10], which observed very fluctuating abundance from year-to-year. Even though fishing characteristics may vary greatly among Mediterranean area (mesh size, or net height and length), our data are consistent with other studies regarding yields [7, 15].

Indeed, the sustainability of the SSF is enabled with the great dynamism of the fleet, which is capable of changing fishing tactics/métiers by alternatively using different fishing gears depending on the abundance of the target species [10]. The observed distribution pattern of the SSF within the GLMNP is also in agreement with the SSF around Mediterranean as the main factors seeming at stake are for example fisher’s knowledge, species abundance, closeness with harbour. This can also be explained by the captains' desire to avoid trawler fishing areas located beyond 3 nautical miles. Indeed, the latter have severely damaged their materials in the past. In this study, all species caught by the SSF had mostly reached maturity. For instance, red mullets were caught near shore at sizes over 15 cm Total Length (TL), hakes were constituted by specimens over 30 cm TL and gilthead seabream were over 20 cm TL. Hence, besides avoiding spatial competition with trawlers, catches from the SSF greatly contrast with trawling activities which capture immature individuals for several species (i.e. octopus, hake, and red mullet [9,10,25]). From this point of view, SSF can be considered as relatively sustainable fisheries because it also has very low level of bycatch and discards such as suggested by García-Rodríguez and collaborators [10]. The results from this study should nevertheless be nuanced because discards were not precisely known.

To conclude, the main threat to SSF in Europe seemed to be LSF (trawlers mostly), followed by recreational fisheries [11]. Furthermore, as stated by most fishers, they catch smaller quantities of fish in order to sell at fishing stall rather than at the auction where prices are 2 to 5 times lower. Selling on short supply chains throughout the year would therefore be the most effective way to empower this fishery to remain economically sustainable. Selling,

even partially at auction could contribute greatly to increase fishing pressure, thus increasing competition for resource with those who have found economic alternatives. These aspects should be used by decision-makers for promoting SSF products for instance by creating “eco-labelling” sea products [17].

Acknowledgments

The authors would like to deeply thank the fishers who trusted us and accepted to share informations about their activity and more generally the fishers’ prud’homies of Leucate, Barcarès and Saint-Cyprien for their collaboration. They are grateful to the teams of the GLMNP, of the Marine Natural Reserve of Cerbère-Banyuls and of the CEFREM laboratory for their precious assistance during field survey. This study was part of a research project, namely PechePro funded by the French office for biodiversity.

References

- [1] Battaglia P., Romeo T., Consoli P., Scotti G., Andaloro F. (2010) - *Characterization of the artisanal fishery and its socio-economic aspects in the central Mediterranean Sea (Aeolian Islands, Italy)*, Fish. Res. 102 (1-2), 87 - 97.
- [2] Caro A., Neveu R., Gudefin A., Missa A., Lenfant P. (2012) - *Suivi et évaluation des débarquements de la pêche artisanale au sein du Parc naturel marin du golfe du Lion*, Final report, Agency for Marine Protected Area, CEFREM, France.
- [3] Charbonnier D. (1989) - *Pêche et aquaculture en Méditerranée : état actuel et perspectives*, UNEP. Mediterranean Action Plan. Fascicules du Plan Bleu 1.
- [4] Colloca F., Crespi V., Cerasi S., Coppola S. (2004) - *Structure and evolution of the artisanal fishery in a southern Italian coastal area*, Fish. Res. 69 (3), 359 - 369.
- [5] European Commission. (2006) - *Council Regulation (EC)*, No 1198/2006; 27 July 2006, on the European Fisheries Fund.
- [6] European Commission. (2009) - *Green Paper—Reform of the Common Fisheries Policy*. COM(2009). 163 final.
- [7] Goñi R., Adlerstein S., Alvarez-Berastegui D., Forcada A., Reñones O., Criquet G., Polti S., Cadiou G., Valle C., Lenfant P., Bonhomme P., Pérez-Ruzafa A., Sanchez-Lizaso J. L., Garcia-Charton J. A., Bernard G., Stelzenmüller V., Planes S. (2008) - *Evidence of spillover from six Western Mediterranean marine protected areas measured from artisanal fisheries*, Marine Ecology Progress Series. 366, 159-174.
- [8] Gabriel O., Lange K., Dahm E., Wendt T. (2008) - *Fish catching methods of the world*, 4^a ed., John Wiley & Sons, Blackwell Publishing Ltd, Von Brandt.
- [9] García-Rodríguez M., Acón E. (1995) - *Algunos aspectos sobre la biología y pesca de la merluza mediterránea *Merluccius meluuccius* (Linnaeus, 1758) en la Bahía de Santa Pola (sureste de la península Ibérica)*, Bol. Ins. Espa. Oceanogr. IX (1).
- [10] García-Rodríguez M., Fernández Á. M., Esteban A. (2006) - *Characterisation, analysis and catch rates of the small-scale fisheries of the Alicante Gulf (SE Spain) over a 10 years’ time series*, Fish. Res. 77 (2), 226 - 238.

- [11] Guyader O., Berthou P., Koutsikopoulos C., Alban F., Demaneche S., Gaspar M. B., Eschbaum R., Fahy E., Tully O., Reynal L., Curtil O., Frangoudes K., Maynou F. (2013) - *Small scale fisheries in Europe: A comparative analysis based on a selection of case studies*, Fish. Res. 140, 1 - 13.
- [12] Hamdi A., Vasquez M., Populus J. (2010) - *Cartographie des habitats physiques Eunis - Côtes de France*, Convention Ifremer/AAMP n° 09/12177764/FY.
- [13] Koslow J., Boehlert G. W., Gordon J. D. M., Haedrich R. L., Lorance P., Parin N. (2000) - *Continental slope and deep-sea fisheries: implications for a fragile ecosystem*, ICES Journal of Marine Science. 57 (3), 548 - 557.
- [14] Laloë F., Samba A. (1991) - *A simulation model of artisanal fisheries of Senegal*, ICES Marine Science Symposium. 193, 281 - 286.
- [15] Leleu K., Pelletier D., Charbonnel E., Letourneur Y., Alban F., Bachet F., Boudouresque C. F. (2014) - *Métiers, effort and catches of a Mediterranean small-scale coastal fishery: The case of the Côte Bleue Marine Park*, Fish. Res. 154, 93 - 101.
- [16] Matthew S. (2003) - *Small-scale fisheries perspectives on an ecosystem-based approach to fisheries management*, In: FAO (Ed.), Responsible Fisheries in the Marine Ecosystem. FAO, Rome, 47 - 64.
- [17] Maynou F., Recasens L., Lombarte A. (2011) - *Fishing tactics dynamics of a Mediterranean small-scale coastal fishery*, Aquatic Living Resources. 24 (2), 149 - 159.
- [18] Maynou F., Morales-Nin B., Cabanellas-Reboredo M., Palmer M., García E., Grau A. M. (2013) - *Small-scale fishery in the Balearic Islands (W Mediterranean): A socio-economic approach*, Fish. Res. 139, 11 - 17.
- [19] Morgan A.C., Burgess G.H. (2005) - *11. Fishery-dependent sampling: total catch, effort and catch composition*, In: Management techniques for elasmobranch fisheries, No. 474, Food & Agriculture Org. pp.182-200.
- [20] Pauly D. (2006) - *Towards consilience in small-scale fisheries research*, Maritime Studies. 4, 7 - 22.
- [21] R Core Team. (2017) - *R: A Language and Environment Computing*, R Foundation for Statistical Computing.
- [22] Sacchi J. (2011) - *Analyse des activités économiques en Méditerranée : Secteurs pêche-aquaculture*, Plan Bleu, Valbonne.
- [23] Scientific, Technical and Economic Committee for Fisheries. (2018) - *The 2018 Annual Economic Report on the EU Fishing Fleet (STECF-18-07)*, Publications Office of the European Union, Luxembourg, 2018, JRC112940.
- [24] Sternberg M., Faget D. (2014) - *Pêches méditerranéennes. Origines et mutations Protohistoire-XXIe siècle*, Karthala, Maison Méditerranéenne des Sciences de l'Homme, Aix en Provence, France.
- [25] Taieb A.H., Ghorbel M., Hamida N.B.H., Jarboui O. (2010) - *Période de ponte et taille de première maturité sexuelle de la daurade royale Sparus auratus dans les côtes sud de la Tunisie*, Proceeding of the 2nd International colloquium on biodiversity & coastal ecosystem, Oran-Alger, 28-30 November 2010, Cal, 2(1), pp. 283-289.
- [26] Tzanatos E., Somarakis S., Tserpes G., Koutsikopoulos C. (2006) - *Identifying and classifying small-scale fisheries métiers in the Mediterranean: A case study in the Patraikos Gulf, Greece*, Fish. Res. 81 (2-3), 158 - 168.

- [27] Van Hoof L., Salz P., Patijnlaan B. (2001) - *Applying CPUE as management tool*, Proceedings of the XIII Conference of the EAFE. Salerno, Italy, 18-20 April 2001, pp. 18-20.
- [28] Wilcoxon F. (1992) - *Individual comparisons by ranking methods*, In Breakthroughs in statistics Springer. New York, NY, pp. 196-202.

PRECISION AGRICULTURE AND CONSERVATION OF COASTAL LANDSCAPES

F.V. Romano², V. Scalcione¹, P. D'Antonio¹, C. D'Antonio¹, E. Lacetra¹

¹Università degli Studi della Basilicata Safe, via dell'Ateneo Lucano, 25 85100 Potenza

e-mail: paola.dantonio@unibas.it

²Università degli Studi di Roma "La Sapienza"

Abstract – The application of Precision Agriculture strategies represents an opportunity for farmers to obtain economic benefits given by the optimization of inputs and the reduction of the pressure exerted by agricultural systems on the environment, especially in coastal areas. In this context, the present experimentation was inserted, which aimed to evaluate a sprayer for the distribution of pesticide products on cereal crops in the coastal area of Metapontino, an irrigation area with a surface of 280 979 ha. In this area, as demonstrated by the experimentation conducted, the challenge of producing food and at the same time protecting nature and safeguarding biodiversity, it is possible to face it through the introduction of global positioning systems (GPS), a technology capable of integrating the information on soil type, climate, cultivar, crop and farm management, topography and economy.

Methodology

The application of Precision Agriculture strategies represents an opportunity for farmers to obtain economic benefits given by the optimization of inputs and the reduction of the pressure exerted by agricultural systems on the environment, especially in coastal areas.

The management of cultivation practices through the application of variable dosage of production inputs can guarantee numerous benefits, which can be divided into substantially two types of advantages:

- Economic advantages, due to the rationalization in the use of the different cultivation factors;
- Environmental benefits, related to the reduction of the negative impact of agricultural practices on natural resources.

In this context, the present experimentation was inserted which aimed to evaluate a spraying machine for the distribution of pesticide products on cereal crops in the coastal area of Metapontino, the agricultural production area of Matera, and once the cradle of Pythagorean knowledge.

The Bradano-Metaponto irrigation area has an area of 280 979 ha, comprising the territory of 25 municipalities in the Bradano, Basento, Cavone, Agri and Sinni basins in their lower course. 22.2 % of it is equipped for irrigation, while 9.1 % is actually irrigated.

From this point of view, the Bradano-Metaponto area is the most advanced of the Lucanian consortium areas.

There is no doubt that the Metapontino area is the area with the greatest susceptibility to development in the region, not only in the purely agricultural context but in a wider socio-economic context. It is the only territory that since the 1950s and 1960s has recorded a significant demographic increase, expressing growth potential not yet fully expressed.

By virtue of the growing weight that some centrifugal attraction-dependence factors have had towards some neighboring regions and Puglia in particular. The Mediterranean climate, the favorable soil conditions, the flat land, the presence of large works of collection, transport and distribution of the water resource and finally the existence of an adequate infrastructure network have transformed the landscape of the area (until a few decades ago a swamp in which malaria claimed victims) in a very orderly chessboard of vegetables and fruit trees, citrus fruits, olive trees and vines. All these conditions make the metapontine area a highly suitable area for the creation of supply chain processes in the field of fruit and vegetable crops, here characterized by high levels and marked earliness. In terms of transformation and marketing, the area in question is now commonly considered as an "agro-industrial center", due to the level of production specialization achieved, the high profitability of the sector and the levels of employment that are significantly higher than to the rest of the region.

The surface of the irrigation area is 280 979 hectares of which 22 %, that is 62 424 hectares, is equipped for irrigation while 41 %, that is 25 555 hectares, is actually irrigated. The climate of the area is Mediterranean, with average temperatures ranging from a minimum of about 7-8 °C to a maximum of over 30 °C in summer. Precipitation is around 550 mm per year, mainly distributed in the autumn-winter period. The predominant crops in the area are fruit and vegetables, whose diffusion has been encouraged in past years as well as by the favorable pedo-climatic characteristics, also by the good supply of production factors. The main crops are strawberries, cabbage and salads among vegetables, stone fruits (especially peach and apricot) and citrus fruits (oranges and clementines) among the fruit trees, even if the latter are currently experiencing a phase of stasis due the high production and commercial risks associated with their cultivation. The cultivation of the vine is intended for 60 % for the production of table grapes, while the remaining part for the production of wine grapes (for self-consumption or purchased and processed mainly in Puglia). The table grapes, on the other hand, are marketed in part by local operators and in part by extra-regional operators (from Puglia). Next to the fruit and vegetables, which characterizes the coastal strip and the valley floors of the rivers that surround it, in an almost unmistakable way, the landscape is also marked in its innermost and steep slopes by the ancient presence of the olive tree, whose cultivation was already known and practiced in the area by settlers belonging to the settlements of Hellenic origin, as evidenced by the numerous finds found in more than a few companies. While presenting different systems of plants conducted in a modern and rational way, the olive growing of the Metapontino mostly follows the structural characteristics of the province of Matera (small farm sizes and production mainly destined to self-consumption). The use of the cultivation of durum wheat as an income supplement is widespread (frequent part-time phenomena), even in the more flat areas, given the limited number of days per hectare and the relative concentration of cultivation operations in a few months of the year . Most of the cereal farms, due to the small size of the company, have a predominantly family-run business and a subcontracting system limited to harvesting.

The recent launch of the MOCs (Macro Market Organizations, promoted with EU co-financing) and the Organization of Producers activated by the fruit and vegetable CMO have made it possible to become part of established circuits of large organized distribution; suffice it to say that 97 % of Lucanian agricultural exports are concentrated in the fruit and vegetable production of the Metapontino area.

With reference to this last aspect, the problems relating to the management of water resources have assumed a decisive importance for several years already. The reduction, but above all the rationalization of irrigation volumes, in order to lower production costs and limit the impact deriving from excessive water consumption, represent the main objectives that modern agriculture must set itself.

Moreover, the most recent scientific research, in the field of irrigation management in citrus fruit cultivation, is aimed at promoting eco-sustainable agriculture.

To achieve these objectives, it is essential to have the possibility of constant monitoring of the relationships between soil, plant and atmosphere.

It is therefore necessary to provide for socially fair, ecologically sustainable and economically advantageous agricultural activity, through an inclusive process of the parties. Farmers face a twofold challenge: to produce food and at the same time protect nature and safeguard biodiversity. Using natural resources prudently is essential for our food production and for our quality of life.

The changes that are taking place in Italian agriculture can be attributed not so much to a recession, due to changes in the international panorama, but rather to a crisis of technological identity. To make such a profound change possible, it is necessary to carefully review the cultivation practices and technologies adopted in the light of modern achievements in the field of knowledge and technology. Precision agriculture owes its birth and evolution precisely to the potential deriving from the widespread application of new technical solutions to the primary sector. In its essence it consists in the application of principles and technologies for the management of spatio-temporal variability, associated with all aspects of agricultural production. Without variability, the concepts of precision agriculture would have little meaning and probably would never have developed.

- The first phase of its application consists in the measurement and interpretation of variability.
- The second phase uses this information to manage variability, adapting agronomic inputs to local conditions within the field.
- The third phase, perhaps the most important, consists in validating the proposed approach, using indicators capable of measuring the effectiveness of "site-specific" practices. In the event that the results are not satisfactory, the management proposals must be suitably modified before transferring them to the farmers.

Whatever the application sector, there is now a widespread need to develop a useful tool, capable of making the agricultural system productive, profitable and environmentally friendly, through the transition from "generalized" agriculture to the entire farm area (fertilization, irrigation, weeding, variety, uniform sowing density) to a "specific site" which, while retaining an extensive character, starts from a detailed knowledge of the environment and knows how to match the use of production factors to specific local characteristics. The challenge therefore of modern agriculture is to use modern technologies both to identify the processes underlying production and to manage spatio-temporal

variability, in order to maximize economic revenues, always respecting environmental constraints. (scheme of the integrated approach to precision agriculture) The introduction of global positioning systems (GPS) and yield displays, equipped with GPS and mounted on automatic harvesters, has already made it possible to quantify the variations in yield within the fields and to produce production maps, classifying the different areas according to the quantitative and qualitative properties of the product collected. This technology, together with the spread of geographic information systems on computers (GIS) and the ability to process and map attributes related to productivity, thanks to the use of advanced techniques of spatial analysis and dynamic simulation of crop systems, has facilitated the spread of precision agriculture. The georeferenced information on the crop response can therefore be inserted in a GIS and integrated with the information relating to the type of soil, the climate, the cultivar, the crop and farm management, the topography and the economy.

With the availability of acquiring high resolution satellite images, it is now possible to read the Earth's surface and what it covers in an ever more precise and detailed way. The evolution of the reflection and absorption capacity of sunlight at different wavelengths by vegetation is today related to the quantitative and functional development of the same; it is therefore possible, by calculating suitable radiometric vegetative indices, to obtain important indications about the vegetative growth rates of the crops and the possible onset of stress which, in turn, can influence the quantity and quality of the final product. The GPS system offers the possibility of being able to express the position of any point in the plot as a pair of geographical coordinates and to associate information and data relating to it. It also records the variability present within it, coding it and creating a geographical format within a reference system. The use of a satellite receiver in agriculture can find various applications, which can essentially be traced back to the detection of the boundaries of a plot and the determination of the position of a machine operating inside it, so as to be able to create a registration at a point (mapping) and / or the implementation of information (variable dosage distribution).

To this end, the tests carried out have made it possible to evaluate the performance of the distribution, quantity and quality, according to the different guides of the tractor: manual guide, assisted guide and automatic guide with satellite correction.

The results showed a sharp reduction in the failure rates in automatic driving just 0.2 %, as well as the overlaps obtained with automatic driving were 0.2 % compared to 1.5 % recorded with automatic driving.

Alongside these technical data linked to the functionality of the tractor, there is a higher advancement speed with automatic driving, which also reaches 12.6 km/h compared to 6.6 km/h that can be reached with the manual guided machine; this trend is repeated for the turning times, data which therefore express greater maneuverability of the machines driven by self-driving tractors.

Therefore, with a view to an economic and environmental sustainability of crops in coastal areas, the use of these guide systems appears indispensable for optimizing crop interventions in terms of the use of human and production resources according to crop needs, The other serves to ensure production systems that are respectful of particularly sensitive landscapes such as coastal ones.

The study is basic for the implementation of RTK systems for 5G data transmission.

GNSS systems (global satellite navigation system) are proving to be very useful in many aspects of our lives; their integration into mobile devices, then, makes asking where a place is has become a useless question. The satellites continuously transmit information to the terrestrial stations that identify the position of the satellite itself and the time at which it is transmitting the signal (derived from an internal atomic clock) while the user receiver uses its own clock to compare the data received: it can be performed several measurements with different satellites to obtain the position of the receiver according to a principle called trilateration.

Satellite observation allows to optimize the use of water for irrigation, to improve agricultural productivity, to minimize the use of pesticides. For example, the correct use of satellite observation data would improve crop estimates by 200 %, thus facilitating the forecast of food crises and consciously using water and pesticides. Ultimately, help from space makes these activities more sustainable.

If space technologies demonstrate their great ability to support the quality of life on our planet, they have practically exclusivity in supporting human exploration of the universe. Sustainable development is the challenge of these years and it is easy to imagine that it will not be a challenge that we will win simply.

Bibliography

- [1] Bellomo F., D'Antonio P. (2008) - *Come meccanizzare l'oliveto per avere più reddito*; L'informatore agrario, pp. 36-44.
- [2] Bellomo F., D'Antonio P. (2008) - *Using a grape harvester in super-intensive olive cultivation*, Journal of Agricultural engineering 39 (1), 2008, pp.33-39.
- [3] Brisco, B., Brown, R., Hirose, J., McNairn, H. and Staenz, K. (n.d.) - *Precision Agriculture and the Role of Remote Sensing: A Review*. Retrieved on 1st October 2012.
- [4] D'Antonio P., Bellomo F., Arrivo A. (2001) - *Limiti e convenienza per l'impiego delle macchine operatrici. Applicazione a macchine mono e polifunzionali per la viticoltura*, Rivista di ingegneria agraria, pp.147-158,
- [5] D'Antonio P., D'Antonio C., Evangelista C., Doddato V. (2013) -*Satellite guidance systems in agriculture: experimental comparison between EZ-Steer/RTK and AUTOPILOT/EGNOS*, Journal of Agricultural engineering,
- [6] D'Antonio P., Romano F., Scalcione V. N., D'Antonio C. - *Technologies and sustainable development: the case studies of cultural landscapes in the Mediterranean area* IJRDO - Journal of Agriculture and Research ISSN: 2455-7668
- [7] D'Antonio P., Scalcione V. N., D'Antonio C., (2020) - *Innovative systems in the production and organization of forest biomass and urban green areas*, IJRDO - Journal of Agriculture and Research, 6(5), 46-57
- [8] D'Antonio P., Scalcione V. N., D'Antonio C. (2020) - *Sustainable urban green management systems: battery powered machines and equipment*. International Journal for Research in Agricultural and Food Science Vol. 6, Issue-3, March, 2020
- [9] D'Antonio P., Scalcione V. N., (2020) - *Software and satellite technologies for precision agriculture: the potential with the 5 g network*, EPH, International Journal of Agriculture and Environmental Research Vol. 6, Issue-3, March, 2020

- [10] D'Antonio P., Scalcione V. N., Romano F., (2020) - *The use of satellite technology for digital citizenship: experimental tests and investigation methods*, International Journal of Food Science and Agriculture, Vol. 4, Issue 1.
- [11] Esri (2008) - *GIS for Sustainable Agriculture*. GIS Best Practices. New York: ESRI Publications.
- [12] Sohne, W., Heinze, O. and Groten, E. (1994) - *Integrated INS/GPS System for High Precision Navigation Applications*. Record-IEEE PLANS, Position Location and Navigation Symposium, 35(2): 310-313.
- [13] Xiangjian, M. and Gang, L. (2007) - *Integrating GIS and GPS to Realise Autonomous Navigation of Farm Machinery*. New Zealand Journal of Research, 50(1), 807-812.

INTERVENTI DI TUTELA E VALORIZZAZIONE DELLA BIODIVERSITÀ DEL SIC "TORRE DELL'ORSO"- IT 9150004

Cristina Rugge¹, Giulio Ciccarese¹, Antonio Longo¹,
Salvatore Petrachi², Marco Marcello Niceta Poti³

¹ External designers and technical consultants for the Municipality of Melendugno

² Melendugno Municipal Technical Office Manager

lavoripubblici@comune.melendugno.le.it

³ Mayor of Melendugno

comune.melendugno@legalmail.it Tel. 0832.832111 - Fax 0832.832545

Abstract – As part of the POR Puglia 2014/2020 Axis VI Environmental protection and promotion of natural and cultural resources Action 6.5, 6.5.1 Interventions for the protection and enhancement of terrestrial and marine biodiversity the Municipality of Melendugno presented a project for the enhancement of the SIC Torre dell'Orso IT9150004. Despite being 60 % of the territory consisting of unstable dunes to be redeveloped, the situation of the portion of territory is represented by the Mediterranean rivers "Habitat 3280" with permanent flow with the Paspalo-Agrostidion and with sheltered rows of *Salix* and *Populus alba*. The environmental system seemed to be quite critical for any type of surface water management, in fact these were collected and poured into the sea from the Brunese Channel. The project, funded by the EU, addresses, by identifying the appropriate solutions, the problems related to the fragmentation of ecological corridors and it increased the biodiversity with specific reference to the environments crossed by the Brunese canal. These waters are in the hydrographic connection grid named R.E.R. that include in addition to the SIC Torre dell'Orso a zone of the SIC Alimini IT915001. The project involves the enhancement of the Brunese Canal which makes it a fundamental infrastructure through the upgrading of the waterway, the coordination between environmental and rural development policies, the redevelopment and recovery of the landscape of its compromised areas together with the reduction of the pollution and the consequent improvement in the quality of the water poured into the sea. The general objective of the project is to improve the ecological continuity between the most precious natural wetlands of the Adriatic coast: SIC Laghi Alimini, Torre dell'Orso, Palude dei Tamari, ZPS Le Cesine, creating a large-scale ecological corridor. The improvement refers both to the course of the canal, in terms of practicability of the riverbed for aquatic species, and to the lateral environments, in terms of connection between the Brunese course and the wet habitats whose conservation depends on the water supply of the canal and the aquifer as well as the correct management of the hydrophilic vegetation. The ecological continuity also concerns the areas of the canal banks with interventions to remove the longitudinal interruptions of the riparian vegetation, an ecosystem and a fundamental habitat for the fauna that populates the watercourse and its coasts. The planned interventions are: Creation of wetlands outside the river bed; Proper management of the riverbed; Restoration of full viability for the free migration of the river fauna and increase in the diversification of the river bed and the heterogeneity of river habitats; Diffuse pollution control through the use of woody buffer strips to be created with sheltered rows of *Salix* and *Populus alba*, extending the priority habitat present in the area, for the fight against pollution in the Mediterranean Sea and the protection

of the *Caretta caretta* population; Creation of new pools for amphibians and birdlife, in order to create wet habitats, in what in the past represented the retrodunal habitat, capable of hosting a rich biodiversity and increase in shelter sites for amphibians, reptiles, micro-mammals and bats; Realization, naturalization and sustainability of the underpass of the SP297 with the installation of passages for terrestrial fauna and bollards for amphibians; Connection and improvement of habitats along the Brunese canal, restoration and completion of the existing forestal track and elimination of fixed barriers and start-up of a study for the process of securing suspended electric cables in order to reduce bird damage caused by electrocution or impact; Eradication and containment of invasive botanical species; Dissemination and awareness-raising: creation of a birdwatching station and creation of an app for environmental monitoring.

Introduzione

In corrispondenza di aree ad alto valore paesaggistico e naturalistico, risulta prioritario stabilire nuovi obiettivi di tutela ambientale che non consistano unicamente nell'istituzione di aree protette, ma che mirino anche alla realizzazione e/o al ripristino delle relative connessioni biologiche ed ecologiche al fine di garantire la salvaguardia e l'incremento della biodiversità, traducibili nella realizzazione concreta di una rete ecologica. Per dare risposta all'esigenza di creare una corretta connessione tra i siti si è pensato di dare attuazione nel presente progetto all'individuazione di Aree Prioritarie per la Biodiversità e permettere al Canale Brunese di rappresentare, con una corretta gestione un'infrastruttura prioritaria, grazie alla riqualificazione ambientale del corso d'acqua, al coordinamento tra le politiche ambientali e di sviluppo rurale, alla riqualificazione e al recupero paesaggistico delle sue aree degradate e/o compromesse e, attraverso obiettivi finalizzati alla riduzione dell'inquinamento, ottenere il miglioramento della qualità dell'acqua. Alla luce di tali premesse, il presente progetto nasce in particolare con la finalità di ridurre la frammentazione della continuità ecologica del canale e contrastare le principali minacce alla biodiversità che insistono lungo il corridoio ecologico rappresentato dal Brunese.

Materiali e Metodi

I progettisti hanno effettuato una serie di sopralluoghi, in corrispondenza dei vari ambienti naturali, atti all'individuazione delle priorità da considerare per la delimitazione degli interventi da proporre nella proposta progettuale. A seguito di questi, pur essendo il 60 % del territorio costituito da dune instabili, è apparsa abbastanza critica la situazione del territorio rappresentato dall'habitat 3280 "Fiumi mediterranei a flusso permanente con il *Paspalo-Agrostidion* e con filari ripari di *Salix* e *Populus alba*" ambienti totalmente abbandonati e senza alcun tipo di gestione. Il Progetto proposto intende affrontare, individuando le opportune soluzioni, le problematiche legate alla frammentazione dei corridoi ecologici e alla conservazione della biodiversità con riferimento specifico agli ambienti attraversati dal canale Brunese, territorio di rilevante interesse ambientale e naturalistico, attualmente fortemente compromesso per la mancanza di qualsiasi intervento di gestione. L'obiettivo generale del progetto è il miglioramento della continuità ecologica tra le aree umide di maggior pregio naturalistico della costa Adriatica (SIC Laghi Alimini – Torre dell'Orso –

Palude dei Tamari – ZPS Le Cesine) attuando la deframmentazione e la valorizzazione della funzionalità ecologica del territorio, realizzando conseguentemente un corridoio ecologico di vasta scala che collega aree importanti per la biodiversità. A conferma di quanto sopra detto analizzando il documento storico relativo alla bonifica del canale Brunese si comprende che il tratto di costa tra Sant'Andrea e Torre Specchia Ruggieri era formato esclusivamente da paludi e mentre nella zona delle Cesine e fino a Torre Specchia Ruggieri, le paludi erano essenzialmente retrodunali, il territorio del Comune di Melendugno era impaludato ad una distanza dal mare di circa 100 m [Mainardi, 1991]. La palude del Brunese si estendeva per 25 ha tra Torre dell'Orso e Sant'Andrea. Il miglioramento del corridoio ecologico, considerato nel presente progetto, è da intendersi riferito sia all'asta del canale, in termini di percorribilità dell'alveo per le specie acquatiche, sia agli ambienti laterali, in termini di connessione tra il corso del Brunese e gli habitat umidi la cui conservazione risulta dipendente dall'apporto idrico del canale e della falda, nonché dalla corretta gestione della vegetazione idrofila.

Dal momento che la continuità ecologica riguarda anche le fasce spondali, rientrano in quest'ottica anche gli interventi necessari per rimuovere le interruzioni longitudinali della vegetazione riparia che, oltre ad essere una componente ecosistemica e naturalistica con un proprio valore intrinseco, è anche fondamentale quale habitat per la fauna che popola il corso d'acqua e le sue rive. In termini generali questo progetto consentirà di definire il programma delle azioni da realizzare nei prossimi anni per la salvaguardia del corridoio ecologico rappresentato dal Brunese.

Risultati

Gli obiettivi specifici del progetto, mirato alla realizzazione del corridoio ecologico del Brunese, sono di seguito illustrati:

1. Creazione di zone umide fuori alveo.
2. Corretta gestione dell'alveo: ripristino della piena percorribilità alveale per la libera migrazione della fauna fluviale e incremento della diversificazione dell'alveo e dell'eterogeneità degli habitat fluviali.
3. Controllo dell'inquinamento diffuso mediante utilizzo di fasce tampone boscate da crearsi con filari ripari di *Salix* e *Populus alba*, andando ad ampliare l'habitat prioritario presente nell'area, per la lotta all'inquinamento nel mar Mediterraneo e la protezione della popolazione di *Caretta caretta*.
4. Creazione di nuove pozze per anfibi e avifauna, al fine di realizzare habitat umidi capaci di ospitare una ricca biodiversità e incremento di siti rifugio per anfibi, rettili, micromammiferi e chiroterofauna.
5. Realizzazione, naturalizzazione e sostenibilità del sottopasso della SP297 con installazione di passaggi per la fauna terricola e di dissuasori per anfibi.
6. Connessione e miglioramento di habitat lungo il canale Brunese, ripristino e completamento della esistente pista di servizio ed eliminazione di barriere fisse e avvio di uno studio per il processo di messa in sicurezza dei cavi elettrici sospesi al fine di ridurre i danni all'avifauna causati da elettrocuzione o impatto.
7. Eradicazione e contenimento delle specie invasive;
8. Divulgazione e sensibilizzazione: realizzazione di una postazione per il birdwatching e creazione di una *app* per il monitoraggio ambientale.

La necessità di mantenere un'adeguata funzionalità idraulica dei canali ha storicamente reso difficoltosa la valorizzazione delle potenzialità ambientali della rete idrica gestita dai consorzi. Infatti, per svolgere tali funzioni:

- la progettazione dei canali prevede la realizzazione di sezioni regolari, alvei ad andamento prevalentemente rettilineo e opere di regolazione delle portate;
- non sono consentite dinamiche evolutive morfologiche;
- solitamente si effettuano frequenti interventi per l'eliminazione della vegetazione erbacea e acquatica;
- non è generalmente permessa la presenza di vegetazione arboreo-arbustiva lungo le rive, così da favorire le pratiche di gestione dell'alveo;
- il regime idrico è regolato.

La bonifica della palude Brunese, come ci racconta lo storico Michele Mainardi iniziò nel 1922 per finire un triennio dopo nel 1925, mediante l'apertura di un canale nel quale si dovevano raccogliere le acque meteoriche e quelle freatiche affioranti nella bassura, che si sarebbe riversato a mare sfruttando lo scolo naturale, in considerazione delle forti pendenze verso la costa. Oltre alla realizzazione del canale, con dei colatori laterali per la raccolta delle acque di altre vallette laterali, nonché quelle di alcune sorgive, furono realizzate diverse briglie per moderare la velocità dei fluidi (considerata l'altimetria) ed evitare le erosioni delle sponde, nonché due ponti uno sulla strada che dalla masseria Brunese portava a sant'Andrea e uno per pedoni sul canale principale.

La bonifica venne poi completata con l'impianto di una fascia arbustivo – arborea frangivento, a protezione delle colture agrarie retrostanti: si eressero diverse graticciate per fermare il movimento della sabbia delle dune introducendo le seguenti specie: Pino d'Aleppo, Acacia, Mioporo, Gelso, Cipresso, Frassino, mentre lungo le strade di bonifica e i canali si piantarono i pioppi.

La bonifica della palude Brunese se da un lato ha portato benessere alla popolazione piagata dalla malaria e dalla necessità di rendere più colonizzabile il territorio, che richiedeva sempre più territori per l'agricoltura dall'altro ha determinato la modifica del regime naturale delle portate e dei livelli idraulici dell'impluvio naturale della valle che ancora oggi si ripercuotono sugli ambienti laterali connessi al corso principale quali rami secondari e specchi d'acqua che costituivano habitat di rilevante importanza per tutte quelle biocenosi legate agli ambienti umidi e non soltanto all'ecosistema fluviale.

Il regime modificato delle acque ha inciso negativamente su quei corpi idrici isolati e laterali nei quali ha luogo la riproduzione di Anfibi di interesse conservazionistico tra cui il Rospo smeraldino (*Bufo viridis*) e il Rospo comune (*Bufo bufo*), oltre a numerose specie dell'avifauna e dell'entomofauna.

Obiettivo principale degli interventi dietro elencati è quello di ripristinare tali condizioni in maniera sostenibile, senza andare a modificare la struttura del canale.

Tali interventi, infatti, coerentemente con le strategie europee finora descritte costituiscono un'opportunità per incrementare in modo significativo la valenza ecosistemica della valletta del Brunese, favorendo l'espansione degli habitat di Interesse comunitario e favorendo la biodiversità del territorio in oggetto.

Questo obiettivo può essere perseguito con semplici pratiche di manutenzione dei canali meno invasive e con veri e propri interventi di rinaturalizzazione.

Le acque dei canali, infatti, manifestano spesso problemi di qualità che possono

causare danni agli ecosistemi, in quanto vengono coinvolti sia gli ecosistemi delle zone umide che quello marino in cui vengono riversate le acque.

Causa di questa situazione è l'immissione di acque ricche di nutrienti provenienti dalle aree agricole circostanti prive di un qualsiasi sistema di depurazione, la presenza di scarichi puntiformi che riversano nei canali.

La scarsa capacità autodepurativa dei canali, così come attualmente concepiti, aggrava inoltre il problema: sezioni regolari prive di disomogeneità, scarsa presenza di vegetazione in alveo e lungo le sponde e tracciato tendenzialmente rettilineo, diminuiscono, infatti, i tempi di residenza delle acque e la presenza di comunità biologiche utili per la degradazione naturale degli inquinanti.

Una corretta strategia utile per il miglioramento della qualità delle acque richiede azioni volte al recupero della capacità autodepurativa dei canali e del territorio, che possono generare benefici anche nei confronti della biodiversità (coerentemente con quanto richiesto dalle linee guida del PAF, dai piani di Gestione dei siti Rete natura 2000 e dalle Misure di Conservazione approvate con reg. Reg. 6/16), del paesaggio (coerenza col PPTR), della stabilità delle sponde, della fruibilità (Piano di Gestione), e così via.

Una delle principali problematiche evidenziate nelle nuove strategie dell'UE per la biodiversità è quella della perdita della qualità dell'acqua le cui cause principali sono il cambiamento degli habitat, l'eccessivo sfruttamento delle risorse naturali, l'introduzione e diffusione di specie esotiche invasive (obiettivo 5: combattere le specie esotiche invasive delle nuove strategie dell'UE per la biodiversità) e i cambiamenti climatici. Tutto ciò grava pesantemente sulla perdita di biodiversità (Obiettivi 1 e 2 delle nuove strategie dell'UE per la biodiversità).

Inoltre, secondo quanto previsto dal PAF approvato dalla Regione Puglia le priorità (F1) relative alle zone umide riguardano, in coerenza con quanto previsto dal presente progetto:

- La deframmentazione degli habitat;
- Il contrasto ad azioni di alterazione e trasformazione antropica,
- Incremento in termini di superficie interessata e di miglioramento qualitativo e strutturale;
- Corretta gestione della risorsa acqua, in termini di qualità, utilizzo, mantenimento di livelli minimi, recupero della risorsa, ecc.

Inoltre, il PAF approvato a livello regionale, relativamente alle priorità legate alle specie (F2) di cui alle direttive Natura 2000 (Habitat e Uccelli), nonché alla strategia Europea 2020 per la biodiversità e per il buon funzionamento della Rete Natura 2000, riconoscendo le zone costiere e le zone umide, quali paludi e pascoli inondatai mediterranei meritevoli di attenzione per il loro mantenimento in buono stato di conservazione, prevede la corretta gestione di alcuni siti riproduttivi e per le specie di uccelli delle zone umide la gestione del livello delle acque, la gestione sostenibile e la creazione di nuovi habitat.

Tali azioni possono essere espletate con i seguenti interventi previsti in progetto: creazione di zone umide fuori alveo - corretta gestione dell'alveo: ripristino della piena percorribilità alveale per la libera migrazione della fauna fluviale e incremento della diversificazione dell'alveo e dell'eterogeneità degli habitat fluviali – controllo dell'inquinamento diffuso mediante utilizzo di fasce tampone boscate da crearsi con filari ripari di *Salix* e *Populus alba* (alberi frondosi e di notevole altezza sono l'habitat di nidificazione ideale per numerose specie dell'avifauna) – creazione di nuove pozze per anfibi e avifauna – naturalizzazione e sostenibilità del sottopasso della SP297 con realizzazione di passaggio per

la fauna terricola – creazione di dissuasori per anfibi in prossimità del ponte della SP297 e installazione cassette per chiroteri. Nel Piano di Gestione dei Siti di Importanza Comunitaria (SIC) della RETE NATURA 2000 della Provincia di Lecce è riportata un'attenta analisi delle minacce e delle criticità che possono interferire con la conservazione della biodiversità dei SIC, con particolare riferimento agli habitat e alle specie floristiche e faunistiche di interesse comunitario: il principale fattore di minaccia, essendo il Sic in oggetto, caratterizzato dalla presenza di aree umide, è rappresentato da: Cod. 701 – Inquinamento dell'acqua.

Al fine di scongiurare tale fattore negativo gli interventi previsti in progetto si ripropongono di migliorare la qualità dell'acqua, oltre che con la corretta gestione della vegetazione in alveo e con la realizzazione di zone umide fuori alveo, che con diversi sistemi effettueranno una discreta depurazione dell'acqua (come sarà ben precisato nel capitolo relativo agli interventi), con il controllo dell'inquinamento diffuso mediante l'utilizzo di fasce tampone boscate da crearsi con filari ripari di *Salix* e *Populus alba* (habitat prioritario presente nell'area) nell'area a N-E del canale. Gli interventi previsti in progetto prevedono anche la realizzazione di un'app per il monitoraggio degli ambienti e della fauna. Tale sistema di monitoraggio coinvolgerà gli utenti e i visitatori del SIC soddisfacendo le priorità strategiche di sensibilizzazione e cooperazione previste nel punto F3 del PAF. In termini generali questo progetto consentirà di definire il programma delle azioni da realizzare nei prossimi anni per la salvaguardia del corridoio ecologico rappresentato dal Brunese. Il presente progetto di riqualificazione ha prioritariamente definito i problemi, ambientali e antropici, che incidono sulla funzionalità ecosistemica del canale e degli ambienti ad esso connessi.

L'elenco seguente sintetizza le principali problematiche riscontrate lungo l'impluvio del Brunese:

- *Problematiche idrauliche*
 - Rischio idraulico a causa di:
 - aumento delle portate dovuto all'urbanizzazione e conseguente impermeabilizzazione del territorio; capacità di deflusso non sufficiente a causa della presenza di vegetazione in alveo; capacità di deflusso non sufficiente a causa di accumulo di sedimenti in alveo; scomparsa o mancanza di aree di laminazione.
- *Problematiche ambientali ed ecologiche*
 - Scarsa qualità ecologica in termini di:
 - vegetazione in alveo; vegetazione delle sponde e delle pertinenze dei canali; fauna ittica; fauna terrestre; avifauna; anfibi; macroinvertebrati.
 - Qualità dell'acqua non soddisfacente a causa di:
 - scarsa capacità autodepurativa del canale; inquinamento diffuso proveniente da aree agricole.
 - Scarsa connessione ecologica ad elementi di valore ambientale a causa di:
 - presenza di ostacoli insormontabili di natura antropica (manufatti idraulici, artificializzazioni varie, ecc.); fasce e corridoi caratterizzati da specie esotiche e da specie invasive (acacie, rovi, ecc.);
- *Problematiche geomorfologiche*
 - Dissesti spondali a causa di:
 - mancanza di vegetazione al piede di sponda; scarsa coerenza del materiale di sponda e ammaloramento delle difese esistenti; condizioni idrauliche che favoriscono la sedimentazione.



Figura 1 - Particolare: realizzazione di zone umide al di fuori dell'alveo in prossimità del canale Brunese.

Figure 1 - Detail: creation of wetlands outside the riverbed near the Brunese canal.

- *Problematiche legate alla qualità paesaggistica e fruitiva*
 - Scarsa qualità paesaggistica a causa di:
 - presenza di rifiuti in alveo; banalizzazione del paesaggio (perdita degli elementi naturali, storici e architettonici); impedimenti nella fruizione del canale a causa di: difficoltà ad accedere al canale (per birdwatching, sosta, passeggio, ecc.); mancanza di percorsi appositi (attrezzati o meno) per percorrere le sponde a piedi, in bicicletta, a cavallo, ecc.

Sulla base delle problematiche in atto, lungo l'asta del canale e delle opportunità offerte dal territorio, il progetto di riqualificazione ha chiaramente definito gli obiettivi di tipo ambientale e antropico che intende conseguire. Una volta delineate le aree e gli habitat a maggior rischio per la conservazione della biodiversità e le specie ad esse correlate con maggior valore conservazionistico con attento riferimento alle specie e agli habitat inclusi nelle Direttive Habitat e Uccelli si è passati a raffigurare le attività di conservazione da attuare. L'elenco seguente sintetizza i principali obiettivi che si vogliono perseguire con la riqualificazione del canale e dell'ambiente ad esso limitrofo:

- **Obiettivi idraulici e morfologici**
 - diminuzione del rischio idraulico;
- **Obiettivi ambientali ed ecologici**
 - miglioramento della qualità dell'acqua;
 - miglioramento della vegetazione;
 - miglioramento della vegetazione acquatica;
 - miglioramento degli habitat (per fauna ittica, anfibi, avifauna, fauna terrestre);
 - riconnessione ecologica.

- **Obiettivi paesaggistici e sociali**
 - riqualificazione paesaggistica del canale;
 - riqualificazione fruitiva del canale.



Figura 2 - Fiume a meandri: tecniche di gestione a basso impatto della vegetazione ("manutenzione delicata").

Figure 2 - Meandering river: low impact vegetation management techniques ("gentle maintenance").

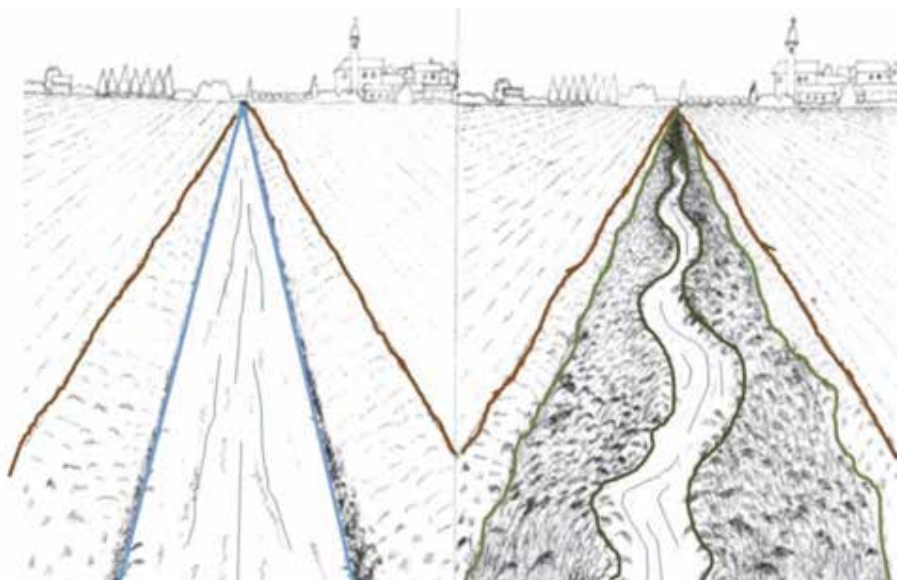

Figura 3 - Schema di progetto di una fascia tampone con canale di carico per il trattamento dei carichi di azoto (N) e fosforo (P) convogliati dal deflusso sotterraneo.

Figure 3 - Design scheme of a buffer strip with loading channel for the treatment of nitrogen (N) and phosphorus loads (P) conveyed by sub-surface runoff.

La strategia adottata dal presente progetto a lungo termine permetterà di ottenere i seguenti risultati controllare i processi di evoluzione naturale della copertura vegetale per favorire l'espansione degli habitat di Interesse comunitario e con la conservazione degli habitat e l'aumento della biodiversità ottenere il ritorno e/o la conservazione di specie faunistiche di interesse comunitario.



Figura 4 - Realizzazione, naturalizzazione e sostenibilità del sottopasso della SP297 con installazione di passaggi per fauna terricola e di dissuasori per anfibi.

Figure 4 - Construction, naturalization and sustainability of the SP297 underpass with installation of passages for terrestrial fauna and amphibian deterrents.

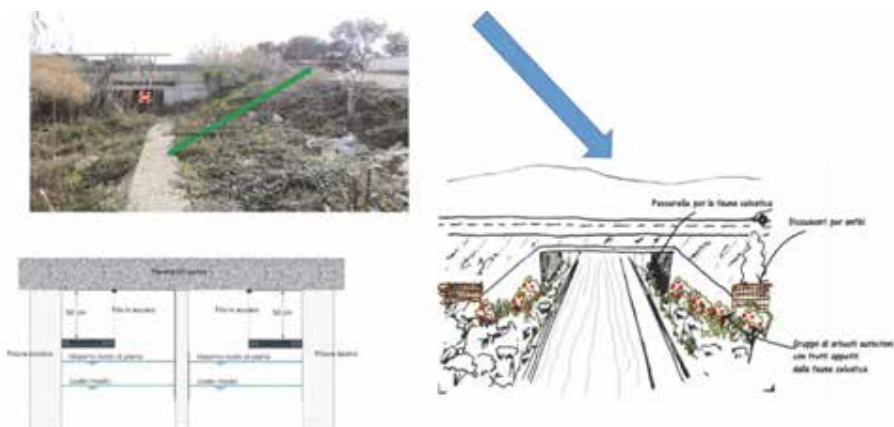

Figura 5 - Postazione per l'osservazione della natura.

Figure 5 - Nature watching post.

Discussione

Gli interventi previsti nel presente progetto risultano coerenti con la strategia delle politiche europee, nazionali e regionali, in particolare con le linee di indirizzo del PAF, dei Piani di gestione dei siti Natura 2000 e delle linee dettate dalle Misure di Conservazione approvate con Regolamento Regionale 6/6 e con quanto previsto dal PPTR. La biodiversità, ossia la straordinaria varietà di ecosistemi, specie e geni che ci circonda, non solo costituisce una risorsa in se stessa, ma fornisce alla società un'ampia gamma di servizi ecosistemici dai quali dipendiamo, dalla fornitura di cibo ed acqua dolce all'impollinazione, alla protezione dalle inondazioni e così via. Obiettivo principale dell'UE per il 2020: Porre fine alla perdita di biodiversità e al degrado dei servizi ecosistemici nell'UE entro il 2020 e ripristinarli nei limiti del possibile, intensificando al tempo stesso il contributo dell'UE per scongiurare la perdita di biodiversità a livello mondiale. In linea con quanto previsto dalla Direttiva 92/43/CEE "Habitat", la Commissione europea ha suggerito pertanto agli Stati Membri di redigere dei documenti pluriennali, denominati *PAF - Prioritized Action Framework, in cui individuare, con approccio integrato, le priorità d'intervento per la Rete Natura 2000 per il periodo 2014-2020, attraverso azioni per la tutela di habitat e specie, e programmare il tipo e l'entità dei finanziamenti necessari per realizzarle*. Per questi motivi la Regione Puglia ha approvato il PAF in cui sono indicate le priorità per la tutela e la gestione della rete Natura 2000 e le relative Misure necessarie per realizzarle tenendo conto delle Misure di Conservazione e dei Piani di Gestione dei siti Natura 2000, con il DGR 1296/14. "Rete Natura 2000" è uno dei più importanti progetti europei di tutela della biodiversità e di conservazione della natura.

È una rete ecologica diffusa su tutto il territorio dell'Unione Europea che garantisce il mantenimento a lungo termine degli habitat naturali e delle specie di flora e di fauna minacciate o rare a livello comunitario sulla base delle Direttive habitat e uccelli (Direttiva Habitat - Direttiva 92/43/CEE e Direttiva Uccelli 147/2009/CEE già Direttiva 79/409/CEE) In base agli orientamenti emanati a livello comunitario e statale la Regione Puglia dal 2007 ha finanziato numerosi Piani di Gestione di siti Rete Natura 2000 ai sensi del D.M. 3 settembre 2002 Linee Guida per la gestione dei Siti Rete Natura 2000. Il Piano di Gestione dei SIC della Provincia di Lecce è lo strumento gestionale che ha come finalità generale quella di identificare l'insieme delle misure amministrative, contrattuali e regolamentari e i soggetti preposti ad attuarle, necessari a garantire la presenza in condizioni soddisfacenti degli habitat e delle specie che hanno determinato l'individuazione dei SIC. Tutto quanto sopra premesso, ha portato i progettisti all'individuazione delle priorità da considerare nella delimitazione degli interventi riportati nella presente proposta progettuale.

Conclusioni

Il Progetto classificatosi in posizione utile per il finanziamento relativamente al POR Puglia 2014/2020 - Asse VI - "Tutela dell'Ambiente e promozione delle risorse naturali e culturali" - Azione 6.5 - 6.5.1 "Interventi per la tutela e valorizzazione della biodiversità terrestre e marina", affronta, individuando opportune soluzioni, le problematiche legate alla frammentazione dei corridoi ecologici e all'aumento della biodiversità con riferimento specifico agli ambienti attraversati dal canale Brunese. Tali ambienti sono inseriti nel

Reticolo idrografico di Connessione della R.E.R. e comprendono oltre al SIC Torre dell'Orso parte del SIC Alimini IT915001. Il progetto prevede la valorizzazione del Canale Brunese rendendolo un'infrastruttura fondamentale tramite la riqualificazione del corso d'acqua, il coordinamento tra le politiche ambientali e di sviluppo rurale, la riqualificazione e il recupero paesaggistico delle sue aree compromesse assieme alla riduzione dell'inquinamento e al conseguente miglioramento della qualità dell'acqua riversata in mare. L'obiettivo generale del progetto è il miglioramento della continuità ecologica tra le aree umide di maggior pregio naturalistico della Costa Adriatica: SIC Laghi Alimini, Torre dell'Orso, Palude dei Tamari, ZPS Le Cesine, realizzando un corridoio ecologico di vasta scala. Il miglioramento è riferito sia all'asta del canale, in termini di percorribilità dell'alveo per le specie acquatiche, sia agli ambienti laterali, in termini di connessione tra il corso del Brunese e gli habitat umidi la cui conservazione risulta dipendente dall'apporto idrico del canale e della falda nonché dalla corretta gestione della vegetazione idrofila.

References

- [1] Mainardi Michele (1991) - *Appunti sulle bonifiche melendugnesi* – Provincia di Lecce - Mediateca - Progetto EDIESSE (Emeroteca Digitale Salentina).

MONITORAGGIO, CONSERVAZIONE E INFORMAZIONE NELLA BAIJA DI IERANTO: UN MODELLO CIRCOLARE PER LA GESTIONE DELLE AREE MARINE PROTETTE

Domenico Sgambati^{1,2}, Érica Moura¹, Ala Eddine Said¹, Laura Rueda¹, Etienne Hoarau¹, Lidija Pribelja¹, Daniels Kļaviņš¹, Alba Fagnano², Antonella de Angelis³, Antonino Miccio¹

¹Area Marina Protetta Punta Campanella, 80061 Massa Lubrense, Napoli (Italia),
phone: +39 3382350941, fax: +39 8089877, email: evs.campanella@hotmail.com

²MAREA Outdoors Association, 80065 Sant'Agello, Napoli (Italia)

³FAI Baia di Ieranto, 80061 Massa Lubrense, Napoli (Italia)

Abstract – The species in the world have been decreasing with unprecedented rates and the main reasons for that are human actions. With the sense of protecting nature, many Protected Areas have been created to try to put a brake in this rate of extinction and to support the natural ecological processes. However, a Protected Area, to work well, has to have a management system. The Marine Protected Area of Punta Campanella (Naples, Italy) implemented a 3-way management model that is being implemented in an important area of the park, Ieranto Bay. This model consists of 3 interconnected actions: Monitoring, Conservation and Information and aims to reduce illegal activities and to promote environmental awareness. To work correctly, there are 4 entities involved in this management plan and most of the people involved are youngsters. The presence of these collaborators in the bay is important to control the illegal activities, such as the entrance of non-authorized boats, fishing, anchoring and pollution. The data collected during 7 years show us that the entrance of illegal boats, compared with the legal ones, has been decreasing and the same is happening with the illegal activity anchoring, an activity that causes the worst consequences for an important ecosystem in Ieranto Bay, the *Posidonia oceanica* ecosystem. This is one of the main reasons why is important to give information to people, they cannot be aware about things that they do not know. Besides the data collected from boat activity, a good knowledge as also been done within the organisms in the bay. Hereafter, this knowledge is the base to the guided tours. These activities are highly important to give information in contact with nature and they are increasing within these 7 years. Here, we show one of the best practices of the Park that can be applied in other Protected Areas in order to decrease/control the illegal actions and protect the environment.

Introduzione

Il numero di specie di animali e vegetali nel Mondo sta mostrando una diminuzione senza precedenti, le stime parlano di circa 1 milione di specie minacciati di estinzione e molti di queste sono entrate nella *red list* negli ultimi decenni, ovvero nel periodo di massimo impatto antropico sull'ambiente naturale. Questo fenomeno è causato da diversi fattori, tra i quali i principali sono: la trasformazione degli habitat terrestri e marini; lo sfruttamento diretto di organismi; il cambiamento climatico; l'inquinamento e l'introduzione di specie esotiche invasive. Per esempio, per quanto riguarda il mare, il 66 % degli ambienti marini

sono stati severamente trasformati dall'azione umana e circa il 50 % di copertura di coralli vivi nelle barriere coralline tropicali è stata persa dal 1870 ad oggi [1].

Le Aree Protette (AP) hanno un ruolo fondamentale nella protezione delle specie dall'estinzione e nel sostegno ai processi ecologici naturali [2], sono un buon mezzo per controllare gli impatti e provano a rallentare questo processo al fine di raggiungere il punto di non-ritorno. Di fatti un'AP è definita come un'area geograficamente circoscritta, che è designata o regolamentata e gestita per raggiungere obiettivi specifici di conservazione.

Per quanto riguarda la gestione delle AP, sono due le azioni chiave da mettere in campo:

1. Zonizzazione dell'uso del territorio e creazione di corridoi ecologici intorno alle AP (per bilanciare gli obiettivi di conservazione con gli obiettivi dello sviluppo economico);
2. Governance delle AP e importanza delle istituzioni di rafforzamento (nella gestione basata sulla comunità locale e delle risorse naturali, la maggior parte dell'onere economico e della responsabilità della gestione è ricaduta sulla comunità stessa ed altre istituzioni e gruppi di parti interessate sono scomparsi o hanno mantenuto ruoli minimi) [2].

Più recentemente, le AP hanno dovuto adattarsi rendendo necessari sforzi pratici per mantenere operativi la progettazione e la gestione attenti al clima nella rete globale per garantire l'efficacia a lungo termine per la salvaguardia della biodiversità e degli ecosistemi [3].

La Baia di Ieranto

Il Mar Mediterraneo è considerato un hotspot per il cambiamento climatico [4] e per la biodiversità marina mondiale, contribuendo con più del 7 % di specie [5]. Al centro di questo mare, l'Area Marina Protetta (AMP) Punta Campanella è parte delle 1215 AMP ed Altre aree con Misure Efficaci di Conservazione (OECMs) nel Mediterraneo [6], contribuendo con il suo ricco ecosistema e con le sfide che la conservazione pone in questo tratto di mare ad alta densità abitativa e presenza turistica.



Figura 1 - Mappa dell'Area Marina Protetta Punta Campanella (* localizzazione della Baia di Ieranto).

Figura 2 - La Baia di Ieranto vista da Google Maps.

Figure 1 - Map of the Punta Campanella Marine Protected Area (* location of Ieranto Bay).

Figure 2 - Ieranto Bay from Google Maps.

Il cuore dell'AMP Punta Campanella è la Baia di Ieranto. Sia per ragioni geografiche che per la ricchezza di habitat e di specie, la Baia è sottoposta ad un livello di tutela B – riserva generale – con 2 ulteriori misure di conservazione (fermo pesca per 4 mesi all'anno e divieto di transito a motore, con eccezione per le barche autorizzate – es. visite guidate autorizzate e mezzi di controllo).

Per quanto riguarda la vita sottomarina, le acque mostrano una mescolanza di organismi bentonici (che vivono lungo la costa frastagliate e sui fondali ricoperti di *Posidonia oceanica*) ed organismi pelagici che vengono trasportati all'interno della Baia.

Sin dall'epoca dei romani, la Baia è stata utilizzata come banca di risorse naturali da sfruttare: la roccia calcarea, la fauna ittica, la fauna terrestre, *etc.* Negli ultimi 50 anni, dopo la fine dei lavori di estrazione della roccia calcarea, la cicatrice più evidente nel paesaggio di Ieranto che probabilmente non sarà mai più sanata [7], le acque cristalline della Baia ed il fresco vento di maestrale hanno fatto da attrattore per centinaia di imbarcazioni che, ignare dell'impatto distruttivo, ancoravano sui fondali popolati dalla *Posidonia oceanica* con il risultato di produrre dei danni attualmente ancora visibili sulla distribuzione di questa fanerogama marina.

La Baia in Fondo al Sentiero

Con l'obiettivo di presidiare una delle aree di maggiore valore dell'AMP Punta Campanella, nel 2011, in collaborazione con il FAI – Fondo Ambiente Italiano, è stato creato un programma di tutela, monitoraggio ed ecoturismo nella Baia di Ieranto, dal nome “La Baia in Fondo al Sentiero”, che viene realizzato tutti gli anni sin dalla sua creazione.

Si tratta di un programma quotidiano di verifica del rispetto delle norme di fruizione delle risorse marine, ed un lavoro capillare di informazione e sensibilizzazione degli utenti, legali ed illegali, che arrivano alla Baia, oltre a tante iniziative di seguito elencate: Monitoraggio della fruizione; Riduzione degli impatti antropici (ancoraggio, diportismo, pesca illegale); Informazione e sensibilizzazione dei visitatori; Census degli organismi; Visite guidate in kayak e snorkeling; Scuola di biologia marina sul campo; Volontariato per giovani locali ed europei e Pulizia del mare e delle spiagge.



Figura 3 - Comparazione della Baia di Ieranto prima e dopo dell'istituzione dell'AMP (sinistra: 1995; destra: 2019).

Figure 3 - Comparison of Ieranto Bay before and after the institution of the Marine Protected Area (left: 1995; right: 2019).



Figura 4 - Il modello con le 3 azioni chiave per gestione delle AMP.

Figure 4 - Model with 3 key actions for the MPA's management.

Nel corso delle numerose edizioni del progetto La Baia in Fondo al Sentiero, con l'obiettivo di raccogliere informazioni sulla Baia e proteggerla da diportismo, ancoraggio e pesca illegale, l'AMP Punta Campanella ha sviluppato un modello pilota di gestione che è composto da 3 azioni chiave interconnesse dove il Monitoraggio è l'azione più importante, come riferisce Vierros [8]: la corretta applicazione della gestione adattiva dipende fortemente dal monitoraggio.

Le 3 azioni chiave che si sviluppano di modo interconnesso sono:

- A. **MONITORAGGIO:** comprendere e studiare i principali processi che influenzano l'ambiente naturale della Baia. Lo scopo è quello di registrare: a. la fruizione della Baia da parte dei visitatori (sia via terra sia via mare - numero di persone e barche - ancoraggio, pesca, visite, *etc.*); b. la biodiversità della Baia (censimento della flora e della fauna marina, l'effetto del fermo pesca sugli stock ittici);
- B. **CONSERVAZIONE:** ridurre le attività illegali nella Baia (pesca ricreativa e subacquea, ancoraggio, *etc.*), sensibilizzare i visitatori (un visitatore ben informato avrà un impatto minore di uno inconsapevole) e rimuovere quotidianamente i rifiuti marini, coinvolgendo visitatori e gruppi;
- C. **INFORMAZIONE:** sensibilizzare sulle risorse marine, sulle regole del parco, sulle principali minacce che le specie marine devono affrontare, attraverso un punto informativo e con escursioni eco-compatibili per godere della natura protetta con un basso impatto ambientale (kayak, snorkeling ed escursioni).

Questo modello permette all'AMP di raccogliere delle serie di dati in diversi campi d'azione, sulla base dei quali poter definire possibili scenari per piani futuri di conservazione.

La raccolta dati viene realizzata in collaborazione con diversi operatori di vari enti: l'AMP Punta Campanella in qualità di Ente capofila per quanto riguarda le attività in ambiente marino ed opera con il supporto dei volontari del Progetto M.A.R.E. (progetto del servizio volontario europeo, finanziato dalla Commissione Europea attraverso il programma ESC Corpo Europeo di Solidarietà), il FAI – Fondo Ambiente Italiano in qualità di partner di

progetto, l'Associazione MAREA Outdoors che collabora con il suo team di biologi e guide ambientali escursionistiche.

Il ruolo dei giovani nella pianificazione e gestione attuali e future delle aree protette è stato particolarmente sottolineato negli ultimi anni [9]. Nella Baia di Ieranto i giovani del Progetto M.A.R.E. sono coinvolti in tutte le attività che mirano ad una buona applicazione del modello di gestione, sia per la raccolta dati, che nelle attività di informazione e allontanamento di barche illegali, o nell'informazione con i visitatori.

Materiali e Metodi

Il programma di lavoro nella Baia di Ieranto è iniziato nel 2011, ma è dal 2013 che il lavoro di campo è stato arricchito dalla raccolta di dati su fruizione e biodiversità marina. Ogni anno il lavoro si svolge nel periodo 1 giugno – 30 ottobre con circa 100 giornate di lavoro (giorni del fine settimana per i mesi di giugno e ottobre, lavoro quotidiano per i mesi di luglio-agosto-settembre), dalle ore 10.00 alle ore 18.00.

A. **MONITORAGGIO:** Il monitoraggio viene effettuato via terra – registro giornaliero delle persone che visitano il posto – ma anche via mare – con mezzi ecocompatibili per valutare il numero di visitatori che giungono all'interno della Baia in modo regolare (con mezzi ecocompatibili e/o autorizzati) o in modo irregolare (con imbarcazioni a motore). Altro tipo di monitoraggio è quello biologico, effettuato con campagne *ad hoc* per censire le specie presenti.

1. Presenze via terra: gli operatori contano il numero di visitatori che stazionano nella Baia considerando 4 ambienti principali dove è possibile rinvenirli: spiaggia – piattaforma – mare – pineta – altro (es. sentiero). Tale lavoro viene effettuato quotidianamente in 5 differenti momenti della giornata: ore 10 – 12 – 14 – 16 – 18.
2. Presenze via mare: gli operatori registrano e avvicinano con i kayak dell'AMP Punta Campanella tutte le imbarcazioni che entrano via mare, compilando una tabella dati riportata in allegato che permette di conoscere anche il numero di persone che entra nella Baia "via mare". Per ogni imbarcazione viene registrata:
 - i. L'ora di entrata e uscita dalla Baia;
 - ii. La tipologia di imbarcazione (verificando se si tratta di un visitatore regolare o irregolare), il nome, se si tratta di barca a noleggino, privata, o per visite guidate;
 - iii. Informazioni sui passeggeri: numero, provenienza, conoscenza dell'AMP Punta Campanella;
 - iv. Informazioni sulle attività svolte dall'imbarcazione: transito, ancoraggio, sosta alla boa, sosta alla spiaggia, pesca;
 - v. Eventuale attività di contatto e informazione operata dagli operatori a favore dei visitatori;
 - vi. Note.
3. Biodiversità: sebbene sin dal 2013 vengono raccolti dati sugli stock ittici della Baia e nel 2015 è stata effettuata una campagna di studio sulle alghe superficiali, solamente nel 2017, attraverso l'iniziativa BLUE TEAM in ACTION, è stata compilata la prima lista di specie, animali e vegetali, della Baia di Ieranto. Negli anni seguenti, questo lavoro è continuato attraverso sessioni di snorkeling con raccolta di esemplari e foto identificazione, ad una profondità massima di 3 m.

BARCHE NON AUTORIZZATE															COMUNO	OPERATORE 1/1984	OPERATORE 2/1984	OPERATORE 3/1984	OPERATORE 4/1984				
note																							
		BARCA				PASSEGGERI			ATTIVITA'				MONITORAGGIO										
ORA IN	ORA OUT	TIPO/NOME	NU. PERS. NOI	LUNG. HEZZA	PORTO DI PARTENZA	NRL	ORIGINE	SAN. NO?	TR	SP	AN	PE	BOA	INFO	VIA	NOTE							
1																							
2																							
3																							
4																							
5																							
6																							
7																							
8																							
9																							
10																							
11																							
12																							
13																							
14																							
15																							

Figura 5 - Tabella per la raccolta dati della fruizione via mare per le barche non autorizzate.
 Figure 5 - Table for the data collection of unauthorized boats that cross the Bay.

- B. **CONSERVAZIONE**: gli operatori dell'AMP Punta Campanella informano tutte le imbarcazioni non autorizzate a sostare nella Baia, chiedendo loro di spostarsi nelle zone verdi del Parco. Altra iniziativa di conservazione che viene regolarmente svolta durante i circa 100 giorni di attività del progetto consiste nell'effettuare pulizia dell'arenile, della scogliera e degli specchi acquei della Baia.
- C. **INFORMAZIONE**: le attività di comunicazione ed informazione con il pubblico della Baia di Ieranto vengono effettuate in diversi modi:
1. In mare - durante le attività di monitoraggio delle barche, i visitatori, sia quelli regolari sia quelli irregolari, possono ottenere informazione dagli operatori dell'AMP Punta Campanella sul regolamento e sulle possibilità di fruizione della stessa;
 2. A terra - quando i visitatori raggiungono la parte più bassa della Baia, dove è presente un punto informativo aperto quotidianamente al pubblico per fornire informazioni e materiale divulgativo;
 3. Con visite guidate - quando i visitatori partecipano alle iniziative proposte dal progetto come riportato nell'immagine di seguito:
 - i. Escursione terrestre;
 - ii. Visita guidata in kayak;
 - iii. Visita guidata con maschera e pinne (snorkeling);
 - iv. Esplorazione marina – con kayak e snorkeling;
 - v. Laboratorio di biologia marina – con visitatori o gruppi organizzate (es. scuole);
 - vi. Open days – giornate speciali con visite guidate gratuite per permettere a tutti di conoscere la Baia;
 - vii. Terra-Mare – escursione via terra e via mare attraverso snorkeling e kayak.



Figura 6 - Mappa della Baia con il catalogo delle attività proposte.
 Figure 6 - The map of the bay with the Log of the eco-compatible tours.

Risultati

Questo modello di gestione applicato alla Baia di Ieranto mostra alcuni risultati favorevoli, che ora presentiamo di seguito:



Figura 7 - Grafico delle barche entrate nella Baia negli anni 2013-2019.
 Figure 7 - Diagram of the boats that entered the Bay in the period 2013-2019.

A. **MONITORAGGIO:** Nel corso dei 7 anni di progetto e raccolta dati, la tendenza di barche non autorizzate nella Baia di Ieranto ha mostrato un decremento, passando da 83,50 % nel 2013 a 54,06 % nel 2019. D'altro canto, le barche autorizzate ad entrare nella Baia sono aumentate, passando dal 16,50 % al 45,94 %.

Il monitoraggio degli organismi marini effettuato in questi 4 anni (2015, 2017-2019), ha portato all'identificazione di 207 specie nella Baia di Ieranto. Le due macrocategorie "Alghe" con 51 specie ed "Invertebrati" con 117 specie, raccolgono il maggior numero di organismi. Tra le 207 specie identificate, 5 sono specie invasive, 9 sono endemiche e 14 risultano essere inserite in una categoria con status di protezione.



Figura 8 - Specie confermate nella Baia di Ieranto fino al 2019.
Figure 8 - Confirmed species in Ieranto Bay until 2019.

B. **CONSERVAZIONE:** Sono 761 le barche illegali fermate dagli operatori dell'AMP Punta Campanella. Tale lavoro è ancora più importante se si pensa che ognuna di queste avrebbe potuto ancorare sulla delicata prateria di Posidonia. A tal proposito i dati sono molto rassicuranti: il numero di ancoraggi illegali nei 7 anni di attività ha registrato un decremento del 69,74 %, passando da un valore di 1,52 ancoraggi al giorno nel 2013 a 0,46 nel 2019.

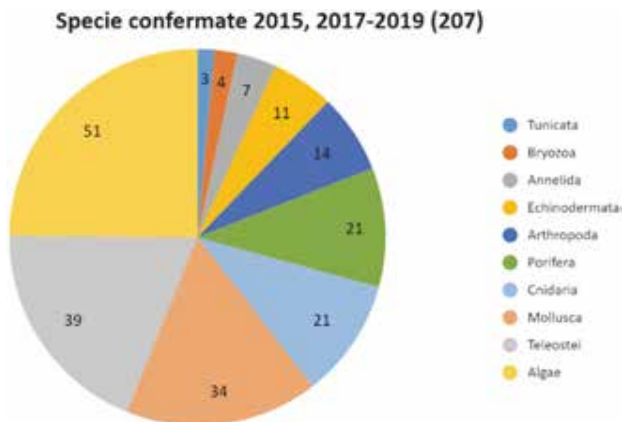

Figura 9 - Grafico sull'ancoraggio delle barche non autorizzate nel 2019.

Figure 9 - Diagram of anchoring activities made by unauthorized boats.

C. **INFORMAZIONE:** Sul totale di 2942 persone entrate illegalmente nella Baia, ovvero con l'uso di barche non autorizzate, 1347 (45,8 %) sono state informate dagli operatori dell'AMP Punta Campanella.

Persone informate (barche non autorizzate)



Figura 10 - Persone informate che sono entrate nella Baia di modo illegale nell'anno 2019.

Figure 10 - Diagram of number of people informed while crossing the bay with illegal boats.

Negli ultimi anni si nota un incremento di persone che partecipano alle visite guidate, se nel 2013 si registravano circa 3 persone al giorno, nel 2019 il valore è aumentato di oltre il 100 %, raggiungendo quasi 6,5 persone al giorno. Quasi tutte le attività proposte mostrano una tendenza in crescita, principalmente nell'ultimo anno.

Evoluzione delle Visite Guidate 2013-2019

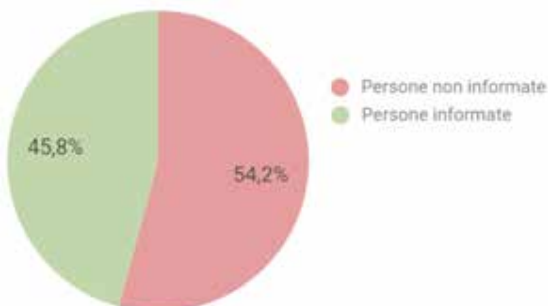

Figura 11 - Grafico della evoluzione del numero di visitatori che hanno partecipato alle visite guidate, media giornaliera, durante 7 anni.

Figure 11 - Diagram that shows the trend of number of visitors that took part to the guided tours during the 7 past 7 years (daily average).

Discussione

Il lavoro di monitoraggio della fruizione della Baia di Ieranto, iniziato nel 2013, mostra una serie di risultati positivi, come si può vedere nei risultati presentati.

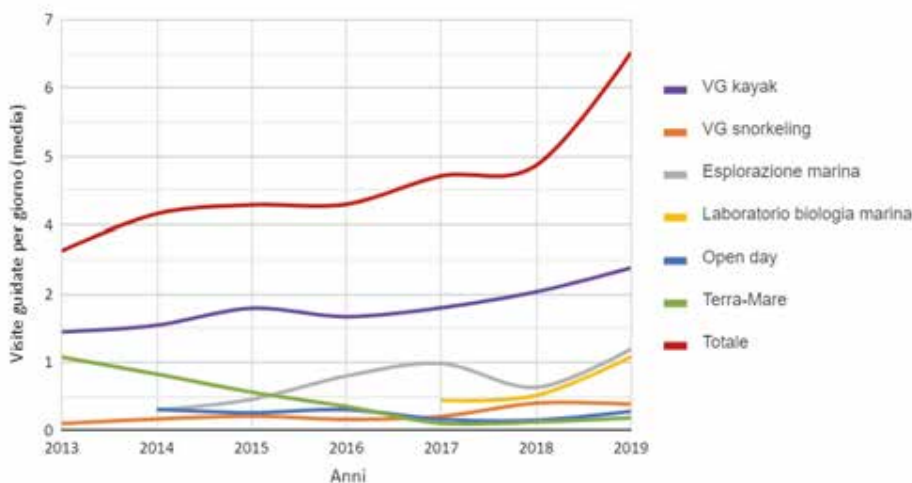
Vedendo gli sforzi chiave menzionati dal Naughton-Treves *et al.* [2], in questa area si prova di applicare lo sforzo di “Zonizzazione dell'uso del territorio e la creazione di corridoi ecologici intorno alle AP” che prevede che la buona qualità degli ecosistemi nelle aree circostanti non è solo dipendente delle aree con più protezione (aree a tutela integrale ovvero “zone A”), ma è anche frutto dello sforzo di tutela nelle zone di fruizione ecocompatibili (aree a tutela parziale ovvero “zone B”), consentendo in modo più diffuso il fenomeno di reclutamento di nuove generazioni di organismi che vanno a colonizzare ed arricchire le aree circostanti.

Con questo modello di gestione si vuol dimostrare l'importanza delle 3 azioni, Monitoraggio, Conservazione ed Informazione, e la necessità di realizzarle contestualmente in un'Area Marina Protetta o in parte di essa. Per applicare questo modello, il supporto di personale ed in particolare di operatori giovani [9], capaci di comunicare in modo diretto e chiaro con i visitatori, è di fondamentale importanza in ognuna delle fasi del processo.

Il MONITORAGGIO rappresenta l'azione centrale e più importante del modello: consente di valutare, attraverso campagne di raccolta e analisi dati, le diverse dimensioni attraverso cui l'uomo influisce sulla risorsa mare. Attraverso i dati è altresì possibile: esaminare i risultati della CONSERVAZIONE (azione chiave B) e dare corrette ed aggiornate INFORMAZIONI (azione chiave C) ai visitatori sullo stato dell'ambiente.

La CONSERVAZIONE racchiude le attività messe in campo per tutelare l'area in oggetto. La riduzione dell'uso di barche a motore non autorizzate, di ancoraggio e pesca illegale, a fronte della promozione di mezzi di trasporto eco-compatibili (kayak e passeggiate) attraverso un metodo di comunicazione costruttiva (insieme all'intervento della Guardia Costiera in casi estremi) è un risultato da annoverare nel campo della conservazione delle risorse naturali della Baia di Ieranto. Questa azione chiave è intrinsecamente collegata al MONITORAGGIO (l'azione centrale) ed offre un'occasione perfetta per informare i visitatori (INFORMAZIONE - azione chiave C).

L'INFORMAZIONE permette alle persone di conoscere (attraverso l'info point) e/o venire a contatto e scoprire la bellezza delle risorse naturali in modo eco-compatibile (con le visite guidate terrestri e marine). Questa azione supporta lo sviluppo dei piani di CONSERVAZIONE (azione chiave B) ed è collegata alla raccolta dati (MONITORAGGIO), utilizzando gli stessi al fine di offrire ai visitatori una migliore comprensione del posto.

L'analisi dei risultati è fatta di un modo trasversale e non individuale, poiché tutte le azioni sono interconnesse. Durante questi 7 anni di attività (2013-2019), e guardando i dati raccolti durante il Monitoraggio, si può percepire un decremento delle attività illegali (le barche non autorizzate nel 2013 passano da 83,50 % a 54,06 % nel 2019). Questi dati, insieme al decremento dell'ancoraggio (-69,74 % nel 2019) ed all'incremento delle barche autorizzate (passate da 16,50 % a 45,94 %), portano ad un aumento della corretta fruizione dell'area protetta. Tale risultato mostra quindi un cambio nel tipo di barche che frequentano la Baia: minor presenza di imbarcazioni illegali che lasciano più spazio ai mezzi ecocompatibili e alle imbarcazioni autorizzate. Le due curve, delle barche autorizzate e delle barche non autorizzate, si avvicinano con il passare degli anni, tendendo ad eguagliarsi a breve. Questo rivela il buon lavoro svolto, sia per la presenza degli operatori nell'area che nelle informazioni fornite.

Relativamente al contatto con le barche illegali, gli operatori dell'AMP Punta Campanella informano tutte le imbarcazioni non autorizzate a sostare nella Baia sulle regole dell'AMP Punta Campanella, chiedendo loro di spostarsi nelle zone verdi del Parco dove il diportismo e l'ancoraggio sono consentiti. Questa attività ha come risultato principale quello di evitare la sosta delle imbarcazioni e l'ancoraggio delle stesse. I dati del 2019 rivelano ancora un'elevata percentuale di persone che entrano via mare ed alle quali non risulta possibile rilasciare informazione (54,2 %) per via dei seguenti motivi: le barche entrano ed escono ad una velocità elevata e non è possibile avvicinarle con i kayak; le barche tendono ad allontanarsi per evitare discussioni; il numero di operatori insufficiente in ore di maggior frequenza durante le quali non è possibile avvicinare tutte le barche e le condizioni meteo avverse non consentono di operare in alcune giornate.

Per quanto riguarda le visite guidate, nel 2019 si registra più del doppio di persone (del 2013) che mediamente in una giornata partecipano alle visite guidate. Anche questo rappresenta un ottimo risultato dato che la conoscenza dell'ambiente naturale, in particolare per il settore marino, ha come conseguenza positiva quella di avere persone più informate e consapevoli, minimizzando di conseguenza gli impatti antropici dei frequentatori.

Quanto ai rifiuti recuperati sulla spiaggia o in mare, non ci sono dati ma si può riferire che non ci sono fonti di sversamento (fiumi o torrenti) all'interno della Baia, ma piuttosto i rifiuti entrano in occasione di venti e correnti favorevoli. Il problema dei rifiuti in mare, che causa la sofferenza o la morte di organismi di tutte le specie è purtroppo uno degli impatti antropici più comuni al giorno d'oggi. A tal proposito risulta più efficiente informare le persone a terra al fine di rallentare il processo di immissione di rifiuti nell'ambiente marino.

Comunque, per proteggere e per informare bisogna anche conoscere quello che il Parco tutela, per esempio la biodiversità marina (le 207 specie identificate fino al 2019) e come questa cambia con il tempo. Oltre alla riduzione dell'ancoraggio, la presenza degli operatori permette anche fermare la pesca illegale, che stravolge gli equilibri di un ecosistema naturale.

Riassumendo, questo modello si svolge sia via mare, monitorando le barche e la biodiversità o attraverso le visite guidate in kayak e/o snorkeling, sia via terrestre, informando i visitatori nel punto di informazione o con le visite guidate a terra. In entrambi i casi, la presenza degli operatori contribuisce ad avere una diminuzione delle azioni illegali.

Conclusioni

Essendo il Mare Mediterraneo un hotspot di biodiversità [5] e del cambiamento climatico [4], è importante avere un impegno straordinario da parte delle AMP per promuovere e far conoscere gli ambienti marini, informando le persone sulle principali azioni che pregiudicano gli equilibri naturali. Solo in questo modo si può conoscere, capire e proteggere quello che è l'ambiente naturale, e quale è l'effetto delle azioni antropiche su di esso [10; 11].

Il modello di gestione, applicato nella Baia di Ieranto dal 2013, rappresenta il risultato di una best practice dell'AMP Punta Campanella rispetto ad una fruizione responsabile di un'area B. All'interno del modello si conciliano l'educazione e la tutela dell'ambiente tramite le visite guidate e le attività di informazione dell'infopoint.

Questo lavoro è reso possibile dalla presenza costante di un gruppo di operatori che si occupano di gestire la zona protetta e di informare al fine di tutelare le specie chiave (es. *Posidonia oceanica*). Il lavoro di informazione ha portato ad accrescere la consapevolezza

sulle problematiche legate all'ambiente naturale e alla possibilità di fruire dei parchi in modo ecocompatibile.

La Baia di Ieranto è così un luogo di sperimentazione per le attività di tutela e promozione della natura dov'è stato applicato questo modello di gestione che mette insieme il monitoraggio, la conservazione e l'informazione. Visti i risultati positivi di questo lavoro, i prossimi passi saranno quelli di continuare il lavoro di monitoraggio della biodiversità; analizzare i dati delle persone che entrano/ancorano nonostante, cercando di capire dove dirottare nuove azioni di informazione e coinvolgimento degli stakeholders; applicare questo modello in altre aree del parco ed esportare tali attività in altre Aree Marine Protette Italiane.

Ringraziamenti

Questo lavoro è stato reso possibile solo grazie alla dedizione e all'impegno dei volontari del Progetto M.A.R.E., dei lavoratori FAI e dei collaboratori MAREA. Con il loro lavoro è stato possibile raccogliere i dati riportati e informare i visitatori, al fine di proteggere la Baia di Ieranto. Speriamo che questa grande iniziativa di cooperazione continui a portare buoni risultati.

Bibliografia

- [1] Nations U. (2019) - *UN Report: Nature's dangerous decline 'unprecedented'; species extinction rates 'accelerating'*, Sustainable Development Goals.
- [2] Naughton-Treves L., Holland M., Brandon K. (2005) - *The Role of Protected Areas in Conserving Biodiversity and Sustaining Local Livelihoods*. Oct Annu. Rev. Environ. Resour 17, 219-52.
- [3] Tittensor D.P., Beger M., Boerder K., Boyce D.G., Cavanagh R.D., Cosandey-Godin A., Crespo G.O., Dunn D.C., Ghiffary W., Grant S.M., Hannah L., Halpin P.N., Harfoot M., Heaslip S.G., Jeffery N.W., Kingston N., Lotze H.K., McGowan J., McLeod E., McOwen C.J., O'Leary B.C., Schiller L., Stanley R.R.E., Westhead M., Wilson K.L., Worm B. (2019) - *Integrating climate adaptation and biodiversity conservation in the global ocean*, Science Advances 5.
- [4] Cramer W., Guiot J., Fader M., Garrabou J., Gattuso J.-P., Iglesias A., Lange M.A., Lionello P., Llasat M.C., Paz S., Peñuelas J., Snoussi M., Toreti A., Tsimplis M.N., Xoplaki E. (2018) - *Climate change and interconnected risks to sustainable development in the Mediterranean*, Nature Climate Change 8, 972-980.
- [5] Coll M., Piroddi C., Steenbeek J., Kaschner K., Lasram F.B.R., Aguzzi J., Ballesteros E., Bianchi C.N., Corbera J., Dailianis T. (2010) - *The biodiversity of the Mediterranean Sea: estimates, patterns, and threats*, PloS one 5, e11842.
- [6] MedPAN, SPA/RAC (2017) - *The 2016 status of Marine Protected Areas in the Mediterranean*, By Meola B., Webster C. Ed, SPA/RAC, MedPAN, Tunis, 222.
- [7] Di Donato R., Russo G. (2004) - *Implementazione di un GIS per analisi a fini gestionali dell'ecologia del paesaggio bentonico nell'AMP di Punta Campanella*, Annali della Facoltà di Scienze e Tecnologie, Università degli Studi di Napoli Parthenope 68, 173-200.

- [8] Vierros M. (2004) - *Some considerations on marine and coastal protected areas network design*, Convention on Biological Diversity, Secretariat of the Convention on Biological Diversity, Montreal, 52-57.
- [9] Secretariat of the Convention on Biological Diversity (2004) - *Biodiversity issues for consideration in the planning, establishment and management of protected area sites and networks*, Convention on Biological Diversity, Montreal, 164.
- [10] Cole M., Lindeque P., Halsband C., Galloway T.S. (2011) - *Microplastics as contaminants in the marine environment: A review*, Marine Pollution Bulletin 62, 2588-2597.
- [11] NOAA (2020) - *State of the Climate: Global Climate Report for Annual 2019*, January 2020.

5 ANNI DI MONITORAGGIO, CONTROLLO E PREVENZIONE DELLA PESCA ILLEGALE NEL PARCO SOMMERSO DI GAIOLA (GOLFO DI NAPOLI)

Maurizio Simeone¹, Marco Solano, Paola Masucci, Silvia Mecca, Eliana Barra

¹Centro Studi Interdisciplinari Gaiola onlus c/o CeRD AMP Parco Sommerso di Gaiola,
Discesa Gaiola - 80123 Napoli (Italy)

Tel. +390812403235, e-mail: m.simeone@areamarinaprotettagaiola.it

Abstract – The Gaiola Underwater Park is a small Marine Protected Area located in Naples (Italy), funded in 2002 in order to preserve the biological and archaeological heritage. In fact, because of the metropolitan context in which it is integrated, the area is subject to constant anthropic pressure, which often results in illegal activities, especially in the fishing sector. In this work, the results of 5 years of monitoring and control of illegal fishing inside the MPA are presented. This research had an important impulse in 2015, thanks to the collected data and to the methodology developed within the Gaiola MedPAN Project. The experience acquired in these years resulted in the funding of the StAMM Project, a permanent station for the monitoring, control and prevention of environmental offences in the MPA.

Introduzione

L'Area Marina Protetta Parco Sommerso di Gaiola, istituita nel 2002, con una superficie di appena 42 ha e circa 2,3 km di costa, è inserita nel contesto metropolitano della Città di Napoli che la sottopone ad una continua pressione antropica. Tra le diverse problematiche che il Parco si è trovato ad affrontare sin dalla sua istituzione sicuramente una delle maggiori è stata la pesca di frodo. È nota la problematica relativa al conflitto tra la necessità di tutelare le aree marine protette quali strumenti di ripopolamento biologico per la salvaguardia sia dei sistemi ecologici costieri mediterranei che della piccola pesca costiera spesso in crisi proprio a causa della concorrenza della pesca intensiva e della pesca illegale [1, 2, 3]. In questo contesto la fascia costiera di Posillipo, e la zona della Gaiola in particolare, sono da sempre identificate, nella tradizione popolare, quali aree notevolmente pescose dove da sempre si è concentrata l'attività di pesca. Negli ultimi decenni, poi, il costante depauperamento delle risorse costiere e la perdita di habitat importanti quali la prateria di *Posidonia oceanica* [4, 5] ha man mano spinto sempre di più l'attività di pesca a concentrarsi sui banchi rocciosi presenti lungo la costa, tra cui il banco della Cavallara, inserito oggi per gran parte nell'AMP di Gaiola [6]. Accanto alla piccola pesca costiera praticata ancora con attrezzi tradizionali, negli ultimi decenni, prima dell'istituzione del Parco, si sono diffuse sempre di più nuove tipologie di pesca altamente distruttive ed illegali, come l'utilizzo di cariche esplosive, potassa caustica e pesca subacquea con le bombole.

Il presente lavoro illustra la strategia adottata dall'AMP Parco Sommerso di Gaiola nell'attività di monitoraggio e contrasto alla pesca di frodo. In particolare, vengono esposti i

dati degli ultimi 5 anni lavoro, in cui, a partire dal Progetto Medpan 2015¹ è stato predisposto uno specifico piano di monitoraggio sulla pesca costiera e la pesca di frodo che è stato portato avanti negli anni successivi ed inserito, a partire dal 2016 nelle attività del Progetto StAMM². L'attività è stata finalizzata sia allo studio che al contrasto attivo delle attività illegali rilevate in collaborazione con la Capitaneria di Porto di Napoli, il settore navale della Guardia di Finanza di Napoli, ed il nucleo Carabinieri subacquei.

Materiali e metodi

L'acquisizione dati è stata effettuata attraverso metodologie di campionamento diretto ed indiretto. L'acquisizione diretta è stata a sua volta differenziata in una prima fase (2015-2016) di raccolta dati sull'intera fascia costiera in cui è inserita l'AMP che va da capo Posillipo all'Isola di Nisida, suddividendola in 9 sub-aree che sono state monitorate da postazioni a terra e da barca (Fig. 1). Parallelamente è stato effettuato un censimento delle marinerie di pesca presenti nei porti nel settore costiero di levante e ponente rispetto al settore costiero in esame, interessando il Comune di Napoli e di Pozzuoli. Durante tale censimento sono stati raccolti i seguenti dati: lunghezza dell'unità da pesca, tipologia di pesca praticata, areali potenziali di pesca.

Nella fase successiva (2017-2019) l'acquisizione dati, mediante censimento visivo diretto, si è concentrata prettamente nell'AMP, che è stata a sua volta suddivisa in 17 quadranti, di cui 7 in Zona B, 4 in Zona A e 6 nelle aree esterne immediatamente confinanti con l'AMP (Fig. 2).



Figura 1 - Area di studio e suddivisione delle 9 sub-aree di indagine.

Figure 1 - Study area and subdivision of the 9 sub-areas of survey.

¹ Small Project MedPAN (Mediterranean Protected Areas Network).

² Il Progetto StAMM (Stazione Ambientale Monitoraggio Marino) è cofinanziato da Fondazione Con il Sud nell'ambito di Bando Ambiente 2015 e vede il partenariato della Soprintendenza Archeologica di Napoli, Capitaneria di Porto e Università degli Studi di Napoli Federico II.

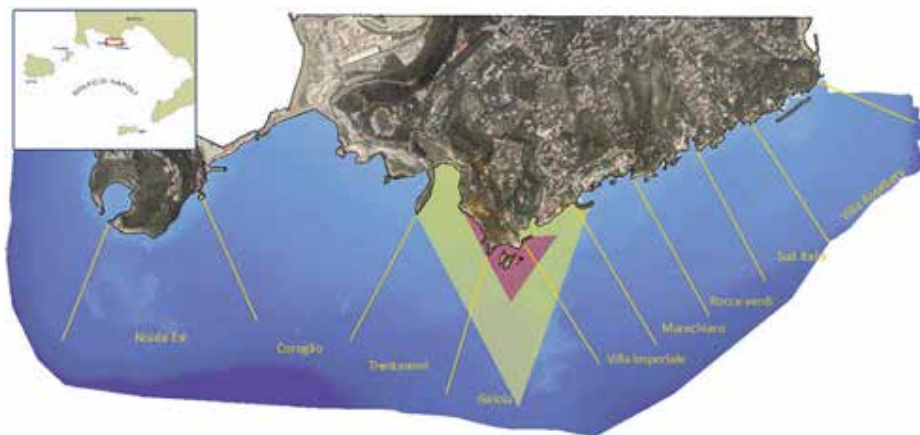

Figura 2 - AMP Parco Sommerso di Gaiola: suddivisione dei 17 quadranti di acquisizione dati.

Figure 2 - MPA Gaiola Underwater Park: subdivision of the 17 data acquisition quadrants.

Per ogni settore sono state censite le seguenti tipologie di pesca: pesca subacquea con le bombole o immissione d'aria da superficie, pesca subacquea in apnea, palangaro, pesca con lenza da posta o a traino, rete a circuizione, rete da posta, nasse (*spearfishing with scuba, spearfishing, longline, fishing line, purse seine nets, gill nets, creels*).

Oltre alla tipologia di pesca eseguite sono stati acquisiti dati sulla lunghezza dell'unità navale utilizzata e la presenza o meno di immatricolazione.

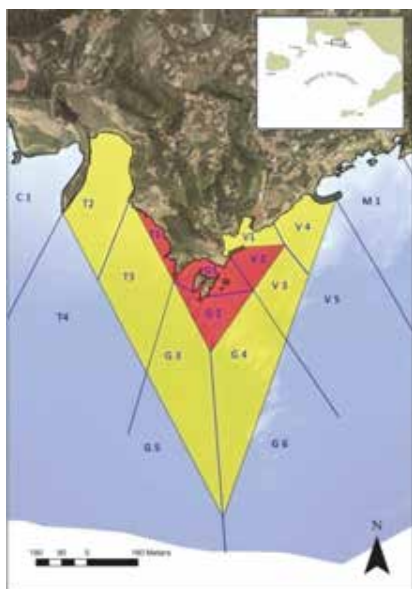
L'acquisizione dati ha seguito un piano di campionamento con specifici appostamenti di monitoraggio differenziati per mesi dell'anno, fasce orarie (Alba, Diurna, Tramonto, Notte), e giorni festivi e feriali. Accanto all'attività di campionamento diretto sono state acquisite altre informazioni tramite campionamento indiretto mediante le cooperative di pesca, la Capitaneria di Porto, e interviste ai pescatori nei porti di attracco. Data la finalità di contrastare la pesca di frodo all'interno dell'AMP, annualmente il piano di monitoraggio è stato adeguato sulla base dei dati riscontrati nell'anno precedente al fine di migliorare l'efficienza dei controlli all'interno del Parco.

Tutti i dati sono stati integrati all'interno di un GIS che ha permesso di correlare lo sforzo di pesca per ciascun settore costiero, diversificato per le varie tipologie di pesca censite.

Risultati

La prima fase di indagini eseguita nei porti di partenza delle marinerie della piccola pesca costiera (SSF) mostra che il settore costiero in esame viene utilizzato in maniera omogenea sia dai pescatori provenienti dal Comune di Napoli (*East Harbours* 53 %) che da quelli provenienti dal Comune di Pozzuoli (*West Harbours* 45 %), mentre la tipologia di pesca più praticata è la pesca con lenza (a traina o da posta), 55÷61 %, seguita

da reti da posta, 24÷26 % e nasse, 7÷11 %. Il dato tra nasse e reti da posta si inverte nei piccoli approdi locali interni al settore esaminato dove la pesca con nasse è superiore alle reti da posta, arrivando al 20 % (Fig. 3).



Figura 3 - Dislocazione delle principali marinerie che utilizzano l'area di Posillipo per l'attività di pesca. Tipologie di pesca praticate nei porti di provenienza (2015).

Figure 3 - Location of the main seafaring that use the Posillipo area for fishing. Types of fishing practiced in the ports of origin (2015).

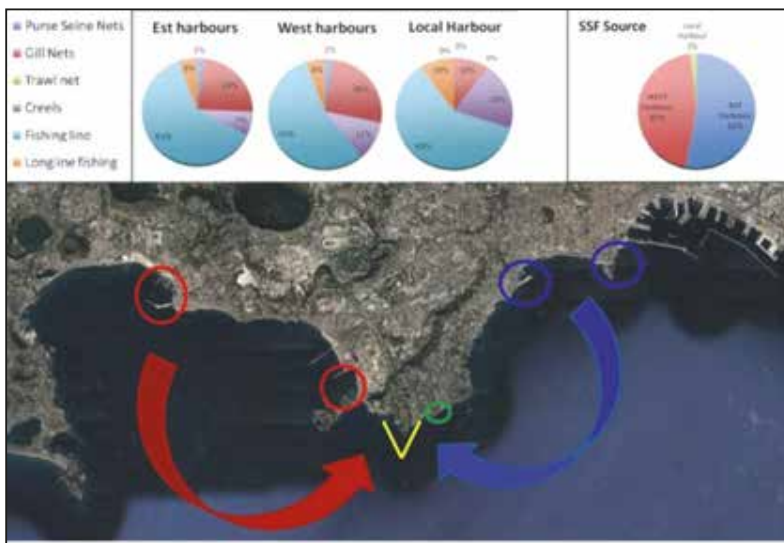

Figura 4 - Eventi pesca censiti nelle diverse sub-aree costiere esaminate (2016).

Figure 4 - Fishing events surveyed in the coastal sub-areas examined (2016).

In Fig. 4 viene mostrato il grafico relativo agli eventi di pesca censiti, per ciascuna tipologia di pesca, nei vari settori costieri individuati all'interno dell'area di studio, ricavati da censimento visivo. Si nota una grossa dominanza in tutti i settori di pesca con lenza (da posta o a traina), eseguita da piccoli natanti non immatricolati che arrivano a rappresentare circa il 72 % delle unità navali dedite all'attività di pesca lungo la costa (Fig. 5).

Per quanto riguarda i dati acquisiti nell'ambito della seconda fase dello studio (2017-2019) focalizzata specificamente sui settori interessati dalla presenza dell'Area Marina Protetta in Fig.6 si riporta il grafico relativo agli eventi di pesca monitorati nel 2018 nei 17 quadranti di rilevamento da cui emerge una netta differenza tra gli eventi di pesca censiti nei quadranti esterni ed interni al Parco. Da notare che i dati censiti all'interno dell'AMP vanno intesi quali eventi di pesca di frodo, non essendo attualmente autorizzata alcuna forma di pesca.

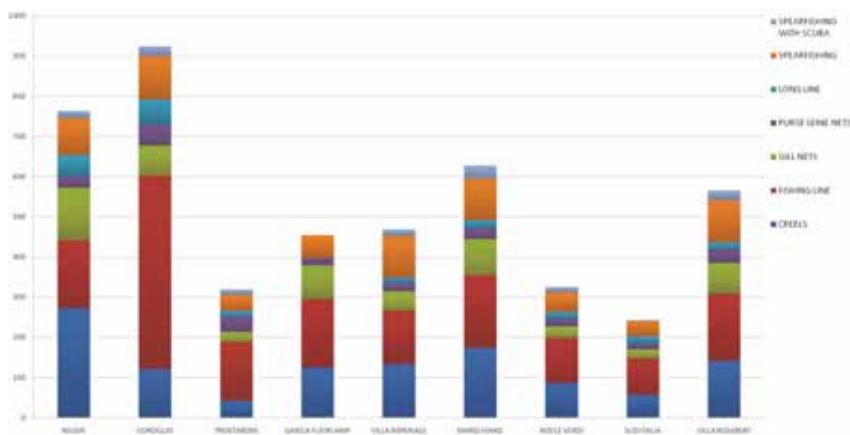

Figura 5 - Percentuali relative di unità da pesca censite differenziate per grandezza e immatricolazione (2016).

Figure 5 - Relative percentages of fishing units surveyed differentiated by size and registration (2016).



Figura 6 - Attività di pesca censite all'interno dei differenti quadranti di monitoraggio del Settore costiero dell'AMP, interni (Zona A + B) ed esterni (2018).

Figure 6 - Fishing activities surveyed within the different monitoring quadrants of the MPA coastal sector, internal (Zone A + B) and external (2018).

Discussione

Dall'analisi dei dati si nota come il settore costiero di Posillipo, all'interno del quale si trova l'AMP Parco Sommerso di Gaiola, per la sua posizione geografica viene interessato sostanzialmente dalle marinerie di piccola pesca costiera provenienti sia da Napoli che da Pozzuoli. La tipologia di pesca più praticata è la pesca con lenza (a traina o da posta), seguita da nasse, reti da posta e pesca subacquea. Da sottolineare il dato relativo alla lunghezza e immatricolazione da cui si evince che la maggior parte delle unità sono tecnicamente da considerarsi pescatori amatoriali, pur svolgendo l'attività in maniera ordinaria e continuativa e utilizzando spesso attrezzi da piccola pesca costiera quali nasse e reti da posta. Andando ad eliminare il dato relativo alla pesca con lenza, vediamo che emerge dominante la pesca con nasse seguita dalla pesca con reti da posta, con dei picchi nei settori di Nisida, Gaiola fuori AMP, Marechiaro e Villa Rosebery (Fig. 7). Trattasi delle aree dove sono presenti i sistemi di secche più consistenti della costa. In particolare, il Banco della Cavallara che occupa il settore di Gaiola e il Banco di Nisida, ospita estese biocenosi di coralligeno costiero (Habitat 1170 - All. I Direttiva 92/43/CEE)³, che sono particolarmente vulnerabili all'impatto diretto da parte di attrezzi da posta come reti e cordate di nasse. Mentre il Banco della Cavallara è per gran parte rientrate nei confini dell'AMP di Gaiola, dove l'azione di controllo negli anni ha abbattuto drasticamente tali attività di pesca ad alto impatto sul coralligeno, facendole spostare nelle zone immediatamente periferiche quali Villa Imperiale e Marechiaro, il Banco di Nisida è ancora oggi esposto all'azione meccanica di rottura ed estirpazione di organismi biostrutturatori tipici di tale biocenosi quali gorgonie, briozoi e alghe coralline incrostanti. Le indagini subacquee in tali zone hanno confermato la presenza di molte reti avviluppate sulle scogliere profonde e il denudamento di estese porzioni di pareti rocciose da organismi coloniali biostrutturatori eretti.

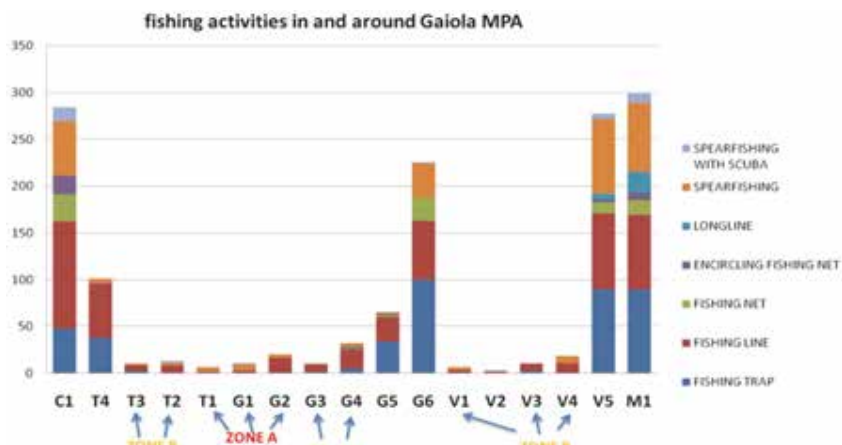

Figura 7 - Percentuale relativa della distribuzione delle diverse tecniche di pesca lungo la costa di Posillipo.

Figure 7 - Relative percentage of the distribution of the different fishing techniques along the Posillipo coast.

³ I banchi Rocciosi della Cavallara e Nisida rientrano nella ZSC IT8030041 "Fondali Marini di Gaiola e Nisida".

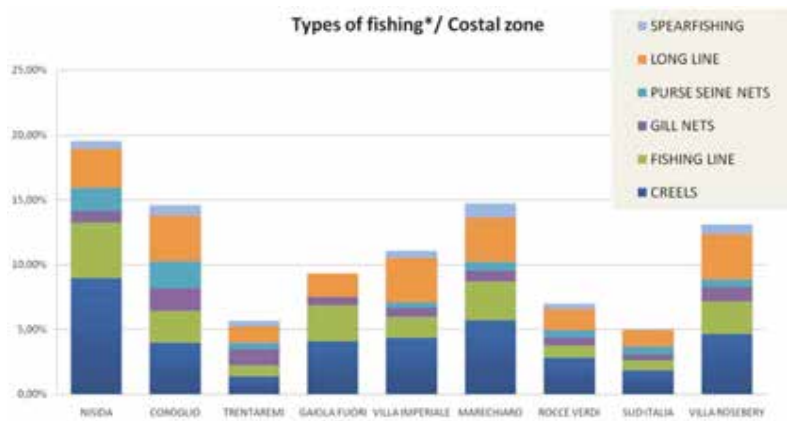

Figura 8 - Sistema Informatico Geografico di correlazione tra la mappa Bionomica dei fondali e l'uso della fascia costiera per attività economico/ricreative (pesca, balneazione, diportismo).

Figure 8 - Geographical Information System of correlation between the Bionomics map of the seabed and the use of the coastal strip for economic/recreational activities (fishing, swimming, pleasure boating).

L'analisi dei possibili impatti delle attività antropiche presenti lungo la costa sulle comunità biologiche marino-costiere risulta particolarmente agevolata dalla realizzazione del sistema informativo geografico dell'area di studio eseguito nell'ambito del Progetto MedPAN [7]. La restituzione cartografica dei dati attraverso il GIS (Fig. 8) permette, attraverso simboli grafici intuitivi, di sovrapporre alla mappa bionomica dei fondali dell'area i dati relativi all'uso della costa per attività antropiche tra cui appunto la pesca. La grandezza dell'icona relativa a la determinata attività di pesca censita dà un'idea immediata della tipologia di pesca dominante in quel settore da cui si possono trarre degli alert sui possibili impatti sulle comunità biologiche presenti.

In ultima analisi i dati raccolti sul monitoraggio della pesca di frodo relativi all'AMP Parco Sommerso di Gaiola ha mostrato un trend molto incoraggiante che mostra un drastico calo di tali attività illecite all'interno del Parco. Il confronto tra i dati censiti nei quadranti interni ed esterni del Parco mostrano con evidenza che, soprattutto i pescatori professionisti, dediti alla piccola pesca costiera si sono spostati ai confini esterni del Parco o in altri areali (Figg. 9 e 10). Permane una componente di pesca illegale praticata soprattutto all'alba e nelle ore serali, soprattutto mediante pesca a traina svolta con natanti di piccole dimensioni non immatricolati. Date le dimensioni ridotte dell'AMP risulta molto difficile

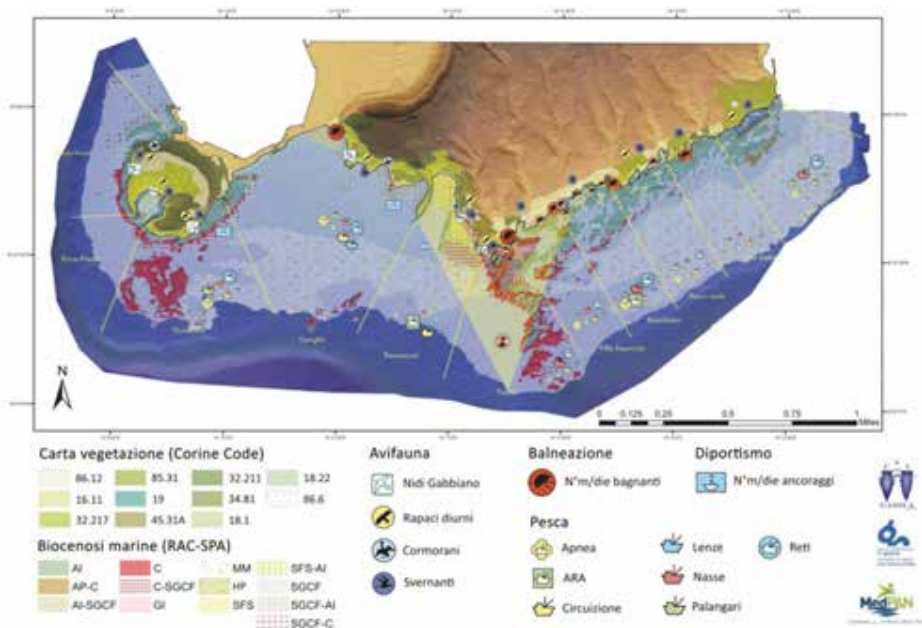
cogliere in flagranza di reato chi pratica la pesca a traina dato che il tempo di attraversamento del parco è di pochi minuti. Permangono episodi di pesca in apnea con una tendenza all'aumento nei mesi estivi dovuta ad un generale esponenziale aumento della frequentazione del parco a scopo di balneazione e nei mesi di novembre-dicembre dovuta a pescatori di frodo di *Dicentrarchus labrax*. A questi si associano episodi di pescatori di frodo di ricci di mare *Paracentrotus lividus* con bombole o con compressore continuo a bordo. Tale tipologia di pesca illegale poco praticata in passato lungo la costa napoletana sta aumentando notevolmente lungo tutto il settore costiero a causa della forte richiesta da parte del settore della ristorazione.



Figura 9 - Differenza tra i censimenti pesca all'interno e all'esterno del Parco (2018).
 Figure 9 - Difference between fishing censuses inside and outside the Park (2018).



Figura 10 - Percentuale relativa delle attività di pesca censite all'interno ed esterno del Parco.
 Figure 10 - Relative percentage of fishing activities surveyed inside and outside the Park.

Conclusioni

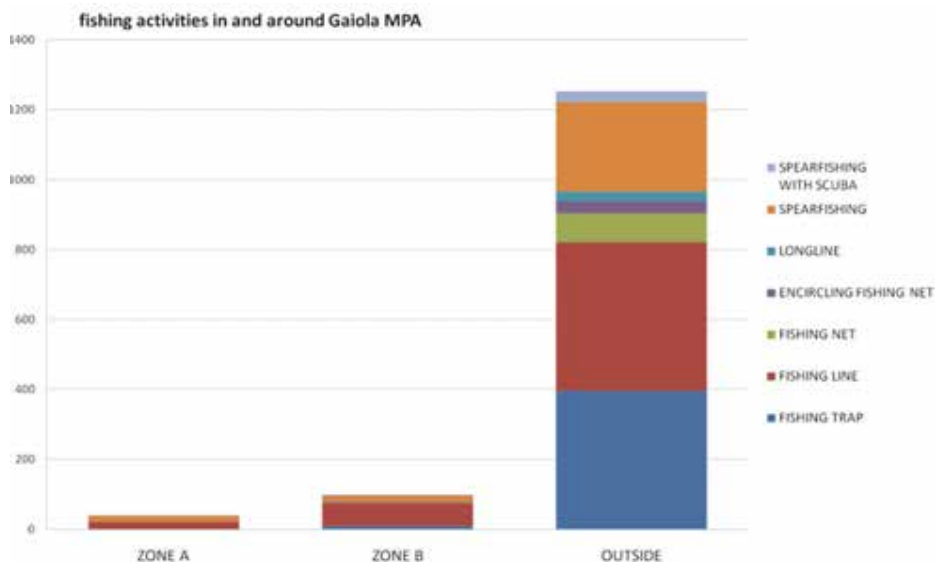
Il progetto si è posto come finalità principali quelle di avere un quadro completo relativo alle attività di pesca lungo il settore costiero di Posillipo in cui insiste l'AMP parco sommerso di Gaiola e parallelamente migliorare l'efficacia ed efficienza dei controlli contro la pesca di frodo all'interno del Parco.

L'attività ha quindi permesso di settare un piano di monitoraggio sempre più efficiente per abbattere gli illeciti da pesca di frodo nell'AMP avendo un quadro della situazione aggiornato nei vari periodi dell'anno, nelle diverse ore del giorno e della notte e nei diversi settori del Parco.

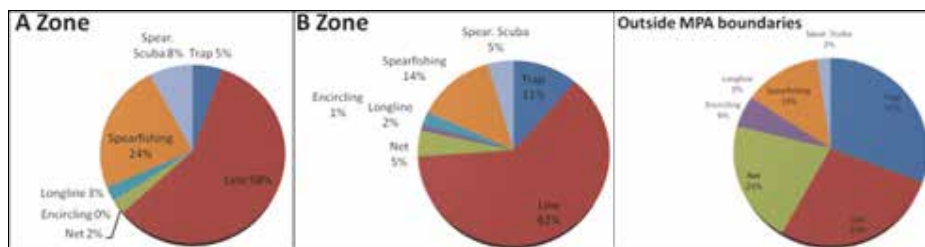
L'integrazione dei dati all'interno del sistema cartografico georeferenziato (GIS) ha permesso di incrociare i dati relativi alle diverse tipologie di pesca con le biocenosi costiere presenti nei diversi settori, fornendo informazioni utili sui rischi a cui tali biocenosi sono esposte a causa delle diverse attività di pesca con particolare attenzione alle biocenosi di pregio quale quella del Coralligeno.

Il Grafico seguente (Fig. 11) mostra come l'azione di monitoraggio all'interno del Parco Sommerso ha portato negli anni ad una sensibile riduzione dell'attività di pesca di frodo, che rappresentava una delle problematiche di conservazione più rilevanti, dato il sovrasfruttamento dell'area negli anni passati e l'estrema importanza che l'AMP rappresenta oggi, quale area di nursery, per il ripopolamento dell'intero settore costiero.



Figura 11 - Trend di decremento delle attività di pesca illegali all'interno del Parco dal 2015 al 2019.

Figure 11 - Trend of decrease of illegal fishing activities within the Park from 2015 to 2019.

Ringraziamenti

Si ringraziano tutti i volontari del Progetto StAMM per la preziosa collaborazione nell'attività di monitoraggio e controllo e tutte le forze dell'ordine a vario titolo impegnate nella tutela del Parco Sommerso di Gaiola.

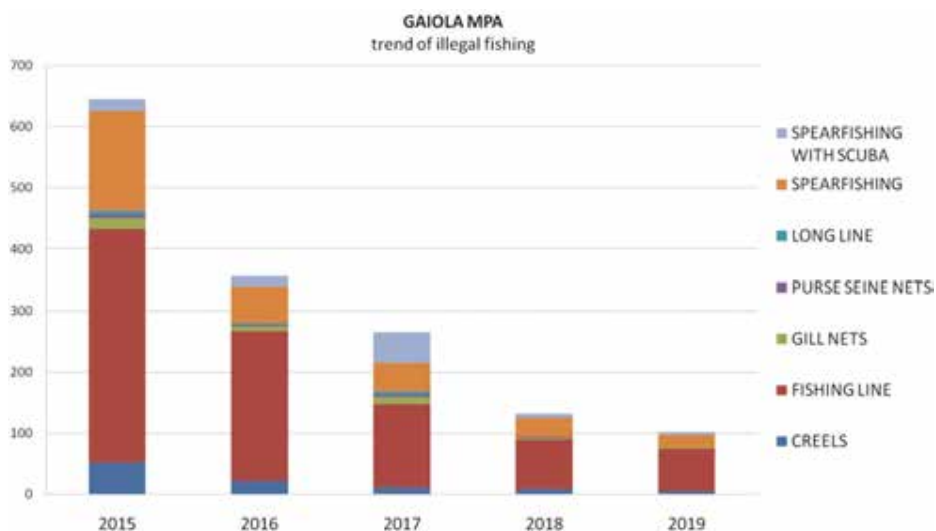
Bibliografia

- [1] Falautano M., Castriota L., Cillari T., Vivona P., Finoia M.G., Andaloro F. (2018) - *Characterization of artisanal fishery in a coastal area of the Strait of Sicily (Mediterranean Sea): Evaluation of legal and IUU fishing*, Ocean and Coastal Management 151, 77-91.
- [2] Guidetti P. (2007) - *Potential of marine reserves to cause community-wide changes beyond their boundaries*, Conservation Biology 21, 540-545.
- [3] Battaglia P., Andaloro F., Consoli P., Pedà C., Raicevich S., Spagnolo M., Romeo T. (2017) - *Baseline data to characterize and manage the small-scale fishery (SSF) of an oncoming Marine Protected Area (Cape Milazzo, Italy) in the western Mediterranean Sea*. Ocean and Coastal Management 148, 231-244.
- [4] Parenzan P. (1956) - *Biocenologia dei fondi marini a Zoosteraceae*, Boll. Zoologia 23, 621-637.
- [5] Simeone M., Russo G.F. (2005) - *Il Parco Sommerso della Gaiola*. In: Carrada G.C., Coiro P., Russo G.F. (eds), *Le aree marine protette*, I Quaderni di uomo e natura 2 Electa Napoli, 85-94.
- [6] Simeone M., Grech D., Masucci P., Pagliarani A., Moraca M., Appolloni L. (2016) - *Progetto MedPAN "Analisi Territoriale per la Gestione Integrata della costa di Posillipo" (Golfo di Napoli): rilievi delle biocenosi bentoniche*, Biol. Mar. Mediterr. 23 (1), 255-257.
- [7] Simeone M., Masucci P., Usai A., Giordano D., De Vivo C., Saccone O., Moraca M., Pagliarani A., De Luca G., Genovese M., Grech D., Tatino F. (2016) - *MedPAN Project "Territorial analysis for the integrated management of the Posillipo coastline" (Gulf of Naples)*, Atti Sesto Simposio Internazionale Il Monitoraggio Costiero Mediterraneo, Livorno 28-29 Settembre 2016; CNR - IBIMET: 299-308.

L'APPLICAZIONE DI TECNICHE INNOVATIVE NEL MONITORAGGIO COSTIERO DEGLI HABITAT PRIORITARI

Rossella Stocco, Laura Pirrera, Emilio Cellini

Regional Agency for Environmental Protection of Calabria, via E. Fermi – 88900 Crotona (Italy)
phone +39 0962 21526, e-mail: r.stocco@arpacal.it

Abstract – The aim of the present paper is to define the advantage to use innovative techniques based on experimental tool to supplement the traditional techniques in marine monitoring, through experience of CRSM-ARPACAL (*Centro Regionale Strategia Marina*) into two regional projects called "SIC CARLIT" and "Musmap". This projects born from the synergy of the following governments ARPACAL (CRSM), Calabria Environment Department, SNPA, ISPRA, CNR (IGAG), University of Calabria (DIBEST and DIMEG), Capo Rizzuto AMP, have been carried on with the purpose of improve the knowledge of the state of the calabrian coasts.

The target of Musmap project, called "multiscale mapping in pilot sites of the Calabria Region of *Posidonia oceanica* and *Cymodocea nodosa* grasslands", was the updating of the previous cartography in six pilot sites distributed on the calabrian coasts, through the interaction of acquisition systems already consolidated with advanced methodologies. The result was the drawing up of 3D cartographic maps of great importance for the protection management and enhancement of priority habitats such as *Posidonia oceanica*.

The SIC CARLIT project, "the sites of Community marine importance in Calabria", still in progress, had two targets: to evaluate the extension and quality of the *Posidonia oceanica* meadows present in the 14 calabrian SIC and to define the ecological status of the calabrian coasts through an update of the CARLIT index.

CARLIT (cartography of littoral and upper-sublittoral benthic communities) is a cartographic methodology permitting a rapid assessment of water quality using rocky-shore macroalgae as biological quality elements. It is based on widely distributed communities that are relatively easy to identify and whose response to anthropogenic pressure is well-known.

Both projects have been also important for the identification of priority habitats, such as Submerged or partially submerged sea caves (8330), Reefs (1170) and Sandbanks which are slightly covered by sea water all the time (1110).

MUSMAP and SIC-CARLIT have shown that in the monitoring of coastal marine ecosystems the experimental techniques to supplement traditional methods can provide more accurate and data with reduced costs and times of work.

Work carried out increased the Calabria region and Ministry of the Environment and Protection of the Territory and the Sea database.

Introduzione

La direttiva "Habitat" (Direttiva 92/43/CEE) costituisce il pilastro della politica di conservazione della natura in Europa. Scopo della Direttiva è "salvaguardare la biodiversità mediante la conservazione degli habitat naturali, nonché della flora e della fauna selvatiche

nel territorio europeo degli Stati membri al quale si applica il trattato" (articolo 2), mentre la Marine Strategy Framework Directive (MSFD, 2008/56/EC) punta al raggiungimento del GES (*Good Environmental Status*) includendo l'habitat 1120 - Praterie di *Posidonia oceanica*. In particolare la Direttiva Habitat impone un'attenta analisi dello stato di conservazione delle specie e degli habitat tutelati dalla norma, una costante valutazione dei trend delle diverse popolazioni, e una verifica dei fattori di minaccia che ne influenzano le prospettive future. Queste valutazioni prevedono una raccolta capillare e standardizzata di dati ambientali e complesse analisi. Tra gli habitat prioritari marini che la Direttiva 92/43/CEE inquadra, ricordiamo: 1110 Banchi di sabbia a debole copertura permanente di acqua marina, 1120 Praterie di Posidonia (*Posidonium oceanicae*), 1130 Estuari, 1140 Distese fangose o sabbiose emergenti durante a bassa marea, 1150 Lagune costiere, 1160 Grandi cale e baie poco profonde, 1170 Scogliere, 1180 Strutture sottomarine causate da emissioni di gas, 8330 Grotte marine sommerse o semisommerse. Tra questi in Mediterraneo e soprattutto per le acque italiane, i più rilevanti sono gli habitat costituiti da "Praterie di posidonia", da "lagune costiere" e da "grotte sommerse o semisommerse" [7].

Lungo le coste calabresi, che si estendono per 740 km, sono stati istituiti 14 Siti di Importanza Comunitaria (SIC) fondali marini e 7 Siti SIC Costieri (Tab. 1).

La distribuzione dei SIC è pressoché continua lungo l'intera fascia costiera regionale ionica e tirrenica. Nel recente periodo ha preso piede una nuova frontiera di studio degli ecosistemi marini e di elaborazione delle correlate cartografie attraverso l'impiego di sistemi innovativi, come l'integrazione dei dati Multibeam Echosounder (MBES) e Side Scan Sonar (SSS) con immagini satellitari e foto aeree acquisite con droni (optical data-drone), che hanno costituito il *core* dei due progetti ARPACAL oggetto del presente lavoro.

Tabella 1 - SIC calabresi.

Table 1 - Calabrian SCI.

	Numero	Codice SIC	Nome SIC
SIC COSTIERI	1	IT9340091	Zona costiera fra Bnatico e Nicotera
	2	IT9350158	Costa Viola e Monte S. Elia
	3	IT9350144	Calanchi di Palzzi Mazza
	4	IT9350141	Capo S. Giovanni
	5	IT9350142	Capo Spartivento
	6	IT9350143	Fiumara Amendolea
	7	IT9350160	Spiegga di Brancalone
SIC FONDALI	1	IT9310035	Fondali Isola di Dino-Capo Scalo
	2	IT9310036	Fondali Isola di Cirella-Diamante
	3	IT9310033	Fondali di Capo Tirone
	4	IT9310039	Fondali Scogli di Isca
	5	IT9340092	Fondali di Pizzo Calabro
	6	IT9340094	Fondali Capo Corzo - S. Irene
	7	IT9340093	Fondali di Capo Vaticano
	8	IT9350173	Fondali di Scilla
	9	IT9350172	Fondali da Punta Pezzo a Capo dell'Armi
	10	IT9320185	Fondali di Staleta
	11	IT9320097	Fondali da Crotone a Le Castella
	12	IT9320096	Fondali di Gabbia Grande
	13	IT9310048	Fondali Crosa-Pietrappaola-Carati
	14	IT9310053	Secca di Amendolara

Materiali e metodi

Per entrambi i progetti, Musmap e SIC – CARLIT, al fine di ottenere dati aggiornati ed immagini ad alta risoluzione, è stato scelto un approccio sinottico in grado di soddisfare le seguenti caratteristiche: Multiscala, Multi piattaforma, Multi sensore, Multilayer, Multitemporale.

Progetto MUSMAP

Quattro delle sei aree di studio ricadono nella fascia costiera tirrenica calabrese: Isola di Dino (CS), Cirella (CS), Briatico (VV), Scilla (RC) e le restanti due sul versante ionico: Isola Capo Rizzuto (KR), Calopezzati (CS). Al fine di mappare e modellizzare le principali biocenosi e rendere le evidenze geomorfologiche presenti nei siti pilota oggetto di studio, sono state incrociate immagini aeree e satellitari, effettuati rilievi mediante ecografici Single beam e MBES e SSS e rilievi video fotografici mediante strumenti ottici multi telecamera (“*underwater towed platforms*” definite anche slitte) [4]. La valutazione della distribuzione spaziale “aggiornata” delle praterie di *Posidonia oceanica* e *Cymodocea nodosa* è stata effettuata “preliminarmente” mediante processamento e fotointerpretazioni di immagini satellitari e/o di ortofoto a colori, solo in fase successiva il dato è stato valorizzato con le acquisizioni ecografiche SSS e MB, questi ultimi integrati e confrontati con quanto è già esistente in letteratura. Sono state adoperate immagini Iperspettrali MIVIS ottenute, con regolare atto di consegna, dal Centro Elaborazioni Dati (CED) del Corpo dei Carabinieri nonché immagini provenienti dal satellite World View 2 e dal satellite RapidEye (dati di provenienza archivio interno ISPRA). Si è fatto uso, inoltre, dei dati forniti dai satelliti del progetto Copernicus, un programma dell’unione Europea finalizzato a sviluppare servizi di informazione e osservazione della terra, mediante l’impiego degli stessi. Il programma è coordinato e gestito dalla Commissione europea ed è attuato in collaborazione con gli Stati membri, l’Agenzia Spaziale Europea (ESA), l’Organizzazione europea per l’esercizio dei satelliti meteorologici (EUMETSAT), il Centro europeo per le previsioni meteorologiche a medio termine (CEPMET), le agenzie dell’UE e Mercator Océan. Il telerilevamento consente di ottenere informazioni qualitative e quantitative di “oggetti” posti nell’atmosfera o sulla superficie terrestre senza che vi sia contatto alcuno con l’oggetto studiato, emula alcune azioni che compiamo quotidianamente, ampliando la nostra capacità di rilevare a distanza determinate proprietà degli oggetti che ci circondano e rendendo tali capacità efficaci, veloci ed al tempo stesso applicabili su larga scala. I dati utilizzati per il progetto Musmap sono stati forniti attraverso Satelliti Multi Spettrali: SPOT-5, Seo-Sat, Sentinel 2 – 3, al fine di ottenere: Immagini aeree “iperspettrali” - 102 bande (MIVIS - *Multispectral Infrared and Visible Imaging Spectrometer*); Immagini satellitari “multispettrali” - 8 bande (WorldView2); Immagini satellitari “multispettrali” - 5 bande (RapidEye). Nell’ottica di poter confrontare i dati già acquisiti negli anni precedenti e i nuovi rilievi, ai dati satellitari sono stati aggiunti sia la Mappatura da Immagini Sensore ADAR+Sonar del 2003 che i dati batimorfologici ottenuti mediante indagini con sistema LIDAR da aereo e prodotti nell’ambito del progetto MATTM - PON MAMPIRA, avviato il 24/10/2011, realizzato in collaborazione con il Comando dei Carabinieri per la Tutela dell’Ambiente, gli Enti Gestori delle Aree Marine Protette delle quattro Regioni Convergenza e le Capitanerie di Porto Competenti. Questi dati sono stati poi confrontati attraverso un sistema GIS con un processo di *Intersecting* che ha consentito di determinare le variazioni in termini di superficie per le classi presenti, e di estrarre le tabelle



Figura 1 - *Undewater towed system* dell' ISPRA.

Figure 1 - *Undewater towed system of ISPRA.*

di sintesi per ciascuno dei siti rilevati. Il progetto ha previsto inoltre l'utilizzo di altra strumentazione per la raccolta di dati da elaborare, come APR (aeromobili a pilotaggio remoto) e l'applicazione di una tecnica sperimentale di rilievo fotogrammetrico 3D per il monitoraggio delle praterie di *Posidonia oceanica*. Per le acquisizioni video fotografiche mediante veicolo al traino (Fig. 1), nelle sei aree pilota sono stati condotti rilievi video fotografici a mesoscala. Le acquisizioni fotografiche sono state effettuate con una telecamera GOPRO Hero 3+ (settata in modalità *time lapse*), con un tempo di ripresa dei fotogrammi pari a 0,5 secondi. Contemporaneamente all'acquisizione dei frames fotografici sono state acquisite le coordinate GPS del tracciato, adoperando un GPS data logger Blumax 4404. Mediante le coordinate GPS sono state georeferenziate le immagini, applicando la procedura di taggatura delle foto tramite l'ausilio di un software di *geotagging*. Le acquisizioni sono state effettuate mediante l'impiego di veicolo al traino munito di apparecchiature video-fotografiche "telecamere verticali" (HD) ad alta risoluzione, di proprietà dell'ISPRA [5]. Per quanto riguarda le elaborazioni aereo fotogrammetriche, è stato impiegato un software di modeling 3D. Il processing di modellazione 3D permette di generare, da una sequenza di immagini 2D, una nuvola di punti "Point Cloud" ottenuta dal riconoscimento dei nodi e delle geometrie caratterizzanti l'immagine. Dalla nuvola di punti (*Point Cloud*), mediante gli algoritmi del software, si possono generare le *Dense Cloud* "nuvole dense" dal quale generare le *Mesh* e le *Texture* [6]. I tecnici ISPRA hanno curato il processamento delle immagini aeree e/o satellitari, la validazione dei prodotti classificati, il trattamento dei dati in ambiente GIS ed infine la realizzazione dei prodotti cartografici di sintesi "layout di stampa". Le elaborazioni delle immagini satellitari (correzione atmosferica, correzione colonna d'acqua e classificazione) sono state eseguite dai tecnici dell'Università della Calabria - Dipartimento DIBEST.

Progetto SIC – CARLIT

Nel corso di svolgimento del progetto SIC-CARLIT si è fatto uso della nave oceanografica ASTREA dell'ISPRA con acquisizione di dati morfo-batimetrici in 11 siti SIC fondali marini della Calabria. Con il Multibeam 2040 Kongsberg sono state acquisite 535 miglia nautiche di linee, circa 990 km, in 13 giorni complessivi di rilievi. Parallelamente



Figura 2 - DEVSS, *autonomous surface vehicle*.
Figure 2 - DEVSS, *autonomous surface vehicle*.

sono state condotte elaborazioni e analisi di immagini satellitari ad alta risoluzione tipo Pleiades e World View 2. Negli stessi SIC sono state condotte immersioni subacquee e prelievi di fasci fogliari per la valutazione della condizione dell'habitat prioritario 1120* *Posidonia oceanica*. Al fine di testare una nuova metodologia cartografica per l'Indice CARLIT, nei SIC Fondali di Cirella e Crotona Le Castella, è stata svolta un'attività sperimentale mediante l'impiego di un *Autonomous Surface Vehicle* ASVs (Fig.2) e un APR (Aeromobile a Pilotaggio Remoto). Per le acquisizioni ecografiche è stato adoperato lo strumento di acquisizione Multibeam Kongsberg EM 2040, 300 kHz Range: 4÷280 m *Soundings*: 256 *Resolution*: 0.2 m *Coverage* 3x, quest'ultimo gestito in acquisizione dal software SIS (*Seafloor Information Systems*). Le attività di prospezione ecografica sono state condotte nei tratti di costa ricadenti nei siti SIC fondali marini: Isola di Dino (CS), Isola di Cirella – Diamante (CS), Capo Tirone (CS), Scogli di Isca (CS), Vibo Marina (VV), Capo Cozzo (VV), Capo Vaticano (VV), Scilla (RC) per il Mar Tirreno; e Amendolara (CS), Staletti (CZ), AMP Capo Rizzuto - Le Castella (KR) per il Mar Ionio. Le pre-elaborazioni e le elaborazioni sono state generate dai tecnici del CNR –IGAG e sono stati prodotti i DTM (Modelli Digitali del Terreno) con celle di risoluzione di 1 x 1 m e 0,5 mx 0,5 m; le mappe di riflettività acustica “*Backscatter*” sono state ottenute associando i dati del Multibeam ai dati LIDAR *bathymetry Green*: λ 532 nm *InfraRed*: λ 1064 nm. Al fine di indagare gli habitat superficiali dei siti non mappabili con la nave oceanografica ASTREA sono state utilizzate le immagini acquisite dal Satellite Sentinel II della rete Copernicus e le immagini satellitari WV2 e Pleiades, quest'ultime ottenute dal sistema Panda - ESA (*Planetary Data Access*). I dati Multibeam e quelli satellitari sono stati elaborati con il software di classificazione a oggetti denominato *eCognition Essential* ottenendo delle mappe tematiche accurate delle ecomorfosi caratterizzanti le aree di interesse del progetto. Parallelamente è stata condotta una attività di campo relativa all'acquisizione e all'identificazione visiva delle comunità bentoniche superficiali presenti nella zona litorale, mediante l'uso di un drone. ISPRA, in collaborazione con l'Università della Calabria-Dipartimento DIMEG, ha curato le acquisizioni ecografiche e ottiche con l'impiego del veicolo autonomo di superficie robotizzato ASVs “*Autonomous Surface Vehicles*”, DEVSS munito di Side Scan Sonar Lowrance HDS7 Carbon e Single Beam Biosonics MX Acquatics e con un Drone DJI Mavic PRO con l'ausilio di Sistemi a Pilotaggio Remoto Classe Very Light. I dati acquisiti con il Biosonics sono stati processati con il software Visual Mx Acquatics, mentre i dati acquisiti con Sonar Lowrance HDS 7 sono stati processati con il software ReefMaster. A tale approccio sperimentale è stata comunque associata la metodologia standard del *visual census* secondo quanto stabilito dalla metodologia CARLIT elaborata da [1]; quest'ultima è stata eseguita dai tecnici del Centro Regionale Strategia Marina dell'ARPACAL con ausilio di piccole imbarcazioni ed attrezzatura snorkeling.

Sono state eseguite le modellazioni fotografiche 3D geo-referenziate integrando sensori ottici e acustici di due siti marino costieri, Isola di Cirella e le Castella (Fig. 4 e Fig. 5) ed i cui dati sono ora disponibili per la loro gestione su una piattaforma GIS.

L'alta vocazione turistica della regione Calabria, le valenze ambientali delle sue acque marino costiere e la necessità di tutela e valorizzazione delle praterie di Posidonia oceanica hanno generato i presupposti per la stesura della prima bozza di Legge Regionale a tutela delle praterie stesse. In output di progetto il testo di Legge è stato consegnato nel giugno 2017 al Servizio giuridico-legislativo della Regione Calabria per il vaglio e la successiva pubblicazione.



Figura 4 - *Dense cloud*, dim. 40 m x 7 m, 700 immagini, 15 milioni di punti 3D.
Figure 4 - *Dense cloud*, dim. 40 m x 7 m, 700 images, 15 millions of points 3D.



Figura 5 - *Point cloud processing*.
Figure 5 - *Point cloud processing*.

Progetto SIC- CARLIT

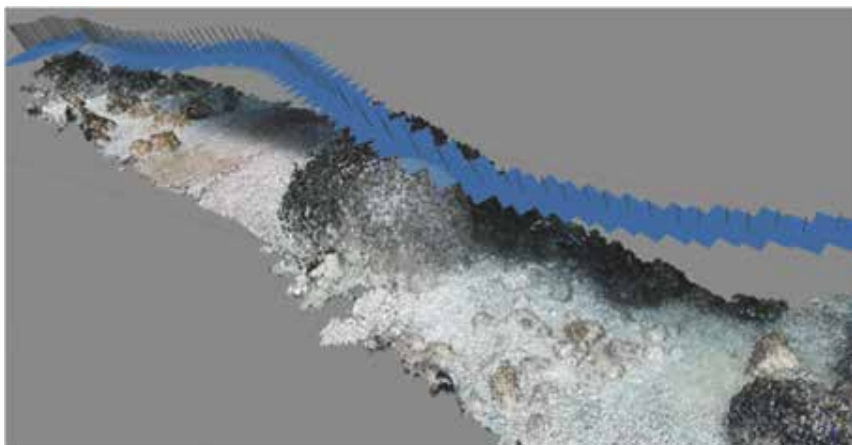
I dati acquisiti e le cartografie prodotte degli 11 Siti SIC oggetto di studio hanno permesso di incrementare le informazioni riguardo la distribuzione degli habitat 1120 Praterie di *Posidonia oceanica*, 1170 Scogliere e 1110 Banchi di sabbia a debole copertura permanente di acqua marina, con aggiornamento del formulario standard per la raccolta dei dati Natura 2000 presso il Dipartimento Ambiente della Regione Calabria. Per ognuno dei SIC oggetto di monitoraggio, al fine di valutarne i cambiamenti in termini di perdita di habitat, sono state confrontate le estensioni, calcolate nell'ambito del progetto SIC CARLIT, con le estensioni desunte dalla mappatura delle fanerogame marine, realizzata nel 2003 e finanziata dal Ministero dell'Ambiente e della Tutela del Territorio e del Mare. In linea generale, i dati acquisiti, non evidenziano particolari cambiamenti in termini di copertura degli habitat prioritari. Per quanto concerne l'applicazione della tecnica fotogrammetrica, a supporto per la mappatura CARLIT dei popolamenti algali della zona intertidale e della frangia infralitorale esposta, si evidenziano ottime possibilità di impiego della metodologia e dei Sistemi Aeromobili a Pilotaggio Remoto (APR) a fronte di una maggiore possibilità di estensione del rilievo nonché di precisione e accuratezza (Fig. 6). Sono stati individuati tutti i tratti di costa rocciosa attraverso la foto interpretazione di ortofoto georeferenziate 1:5000 in ambiente GIS. La valutazione dello Stato Ecologico è stata effettuata per corpi idrici, che rappresentano dei tratti di costa con caratteristiche omogenee. Su un totale di 67 corpi idrici presenti lungo l'intero litorale, solo 18 (27%) sono risultati idonei all'applicazione dell'indice, per un totale di costa analizzata di 25,7 km, distribuita maggiormente lungo il versante tirrenico. I risultati così ottenuti sono stati rappresentati tramite GIS e hanno permesso di valutare l'evoluzione spaziale dei valori di EQR. Dei diciotto corpi idrici analizzati solo 3 risultano con un EQR "buono" (17%), mentre i restanti 15 (83%) presentano un EQR "elevato" (Fig. 7). Non si riscontrano variazioni significative dello stato ecologico tra il versante Ionico (EQR=0,796) e quello Tirrenico (EQR=0,867).

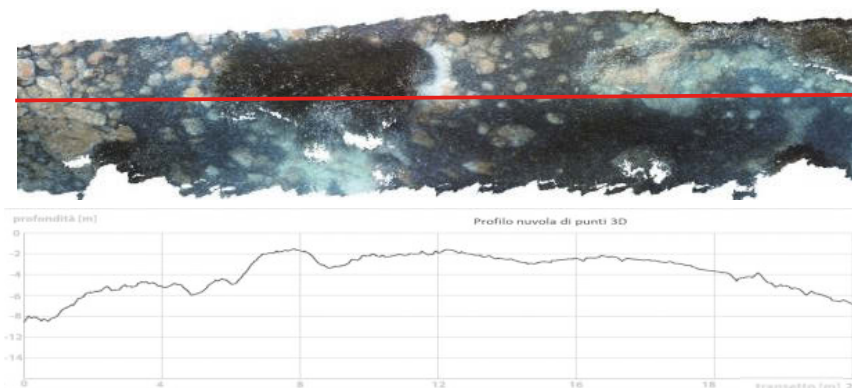

Figura 6 - Rendering immagini 3D.

Figure 6 - 3D images modeling.



Figura 7 - Corpi idrici e relativo RQE.
 Figure 7 - Drainage basins and their EQR.

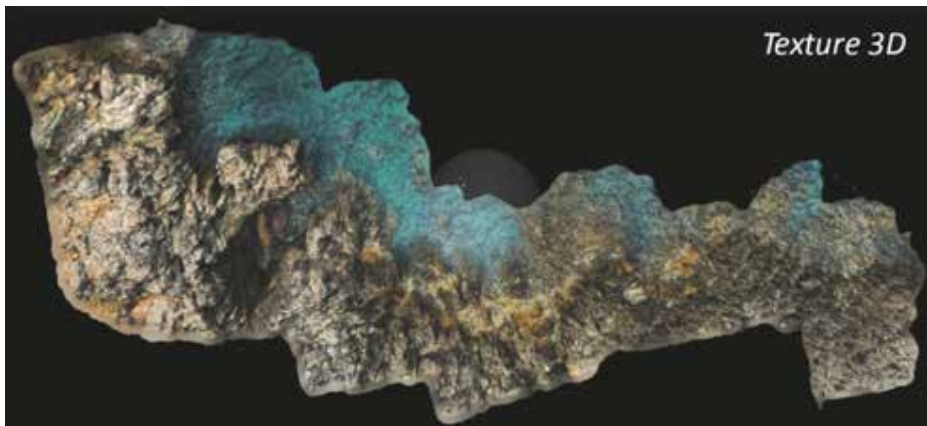

Figura 8 - % gruppi CARLIT.
 Figure 8 - % CARLIT groups.

In totale sono state individuate 14 comunità macroalgali caratteristiche (Fig. 8), appartenenti all'elenco contenuto nel manuale ISPRA relativo al calcolo del CARLIT, dominate dall'ordine Fucales con il genere *Cystoseira*, seguito dagli ordini Dictyotales/Sphacelariales (con i generi *Dictyota*, *Padina*, *Stypocaulon*), Corallinales (con i generi *Lithophyllum*, *Janiae* *Corallina*) e Ulvaes/Cladophorales (con i generi *Ulva* e *Cladophora*). Tra le comunità che più di altre hanno determinato lo Stato Ecologico Buono troviamo quelle con i generi *Corallina*, *Jania*, *Dictyota*, *Padina* e *Stypocaulon*, mentre la presenza abbondante di *Cystoseira* e *Lithophyllum* sono risultate importanti a generare lo Stato Ecologico Elevato.

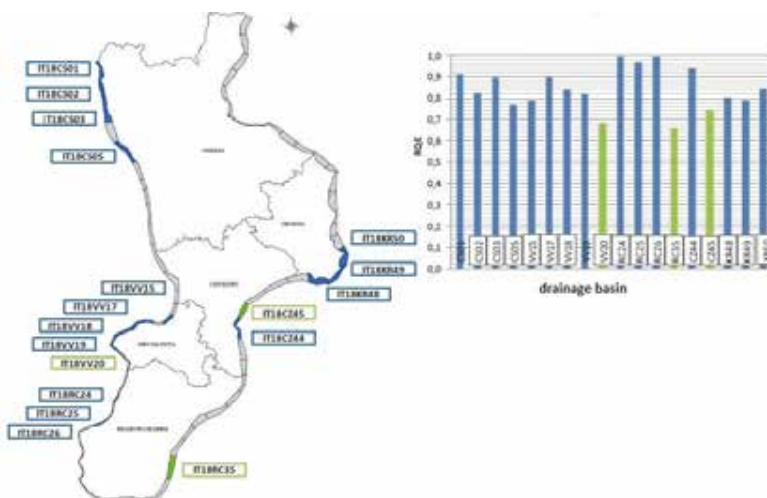
Tra le comunità riscontrate, è necessario sottolineare la presenza della formazione biocostruita a trottoir. Questa formazione, dominata dal genere *Lithophyllum*, è il risultato della lenta crescita e sovrapposizione dei talli e della successiva fossilizzazione di alcune parti morte [2]. Tale formazione, possedendo una distribuzione ristretta (Isola di Dino e Isola di Cirella) e rappresentando un habitat ad alto valore paesaggistico e di biodiversità, necessita protezione, poiché sempre più spesso minacciata da squilibri chimico-fisici della matrice acquosa e dalla distruzione diretta dell'habitat.

La valutazione qualitativa delle acque marino-costiere secondo il metodo CARLIT ha restituito un valore complessivo elevato dello stato ecologico in tutta la Regione, difatti, l'RQE medio a livello regionale è di 0,843. La presenza dei 3 corpi idrici a RQE minore (VV20, RC35, CZ45) potrebbe essere correlata alla presenza di un lieve disturbo antropico prodotto da fonti di tipo agricolo e/o urbano, così come indicato nella base dati regionale relativa alle pressioni antropiche sui corpi idrici.

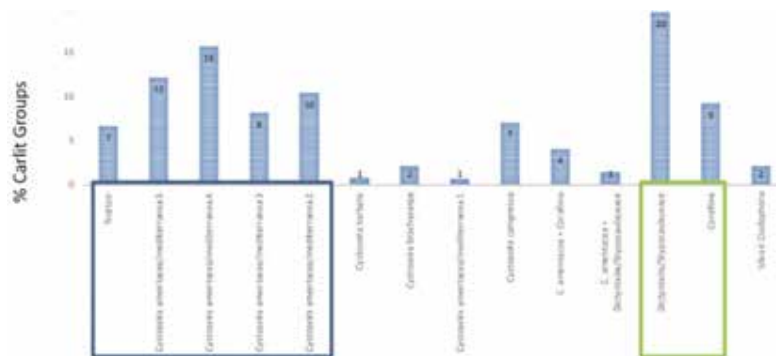
Discussioni

Il monitoraggio è uno strumento essenziale per lo studio dei sistemi ambientali, al quale è possibile ricondurre tre funzioni principali: fornire informazioni sulle variazioni rispetto allo stato desiderato; misurare il successo delle azioni di gestione e conservazione; rilevare gli effetti di perturbazioni e disturbi [3].

La Calabria ha un'alta vocazione ambientale dettata dalla presenza di numerosi habitat prioritari e tale presupposto la rende laboratorio elettivo di progettualità sperimentale finalizzata all'innovazione tecnologica. Un programma di monitoraggio presuppone valutazioni e bilanci tra sforzo di campionamento e tipo di informazione ottenuta, tenuto conto che la raccolta dati generalmente rappresenta la parte più onerosa sia in termini di tempo che di costi. I risultati dei progetti Musmap e SIC-CARLIT hanno incrementato il livello delle conoscenze sullo stato di qualità e conservazione delle fanerogame marine presenti lungo le coste della Regione Calabria, evidenziando aspetti sia positivi che negativi nelle metodologie di indagine applicate. L'impiego delle tecniche di telerilevamento marino delle praterie di *Posidonia oceanica* evidenziano una serie di vantaggi applicativi quali riduzione dei tempi di acquisizione su estese porzioni di territorio; esecuzione di riprese multi temporali della stessa scena con precoce individuazione delle modifiche spaziali delle praterie; elevato dettaglio geometrico e tematico di discriminazione dei morfotipi delle praterie di *Posidonia oceanica* e di altre fanerogame; potenziamento del monitoraggio e della sorveglianza degli habitat marini; impiego di un prodotto gratuito - sistema Copernicus; costi ridotti di esecuzione, a parità di superficie mappata in relazione al censimento tradizionale. Di contro si evidenziano alcune limitazioni come la penetrazione della luce in acqua limitata a 20÷30 m di profondità e la necessità di verifiche dirette finalizzate all'individuazione delle "verità a terra". Per quanto attiene l'ispezione subacquea mediante l'impiego di mezzi teleguidati è possibile affermare che questi ultimi permettono di avere una visione diretta dei fondali, rivelandosi quindi uno dei metodi più idonei nella ricerca e nella mappatura. I rilievi per punti sono particolarmente utili per verificare e tarare quanto evidenziato con i metodi elettroacustici o di telerilevamento ed hanno il grande vantaggio di permettere di distinguere le diverse tipologie di habitat e di effettuare osservazioni e misurazioni che aumentano il valore della

mappatura. La metodologia con *eCognition* ha un duplice vantaggio: consente una rapida classificazione realizzata mediante il riferimento di alcuni oggetti chiave pre-identificati e nello stesso tempo permette di estrapolare i contenuti essenziali di un'immagine. L'utilizzo dei droni consente di programmare l'acquisizione e di eseguirla in piena autonomia ottenendo risultati di maggior risoluzione volando ad una quota ottimale di 150 m; si precisa che, in caso di mancanza di punti di controllo a terra, l'errore riscontrato è dell'ordine dei 15÷20 cm. Tra le problematiche emerse durante l'elaborazione dei fotogrammi figura la torbidità dell'acqua e la cattiva illuminazione durante i mesi invernali oltreché l'errore di allineamento e correlabilità dei software di elaborazione fotogrammetrica rispetto alla linea di costa. Per cercare di risolvere le suddette problematiche è possibile utilizzare i filtri polarizzati di alta qualità e sovrapporre con un minimo 80 % i fotogrammi.

Conclusioni

I progetti Musmap e SIC-CARLIT hanno dimostrato che nel monitoraggio marino costiero le tecniche sperimentali associate alle metodologie tradizionali possono fornire un dato più accurato con riduzione dei costi e dei tempi di esecuzione. L'indice CARLIT, già ritenuto un utile strumento per un primo *screening* su vaste aree, grazie alla semplicità d'applicazione e ai costi limitati, associato alle suddette tecniche sperimentali, potrebbe portare ad un'implementazione/miglioramento delle metodiche nei protocolli di monitoraggio costiero svolto in maniera sistematica (annuale). Di sicuro interesse potrebbe risultare il potenziamento dell'osservazione da satellite e di tecniche LARS, come approccio avanzato per la sorveglianza delle coste e dell'ambiente marino costiero, magari supportando la creazione di un sistema avanzato di monitoraggio dell'ambiente marino con biosensori, veicoli robotizzati e il Remote Sensing. Il modello di "rete istituzionale" tra Enti adottato nei Progetti Musmap e SIC-CARLIT ha consentito di testare nuove metodologie d'indagine da utilizzare nell'ambito di piani di monitoraggio nazionali e internazionali degli habitat marino costieri, favorendo altresì scambi di conoscenza ed implementazione delle competenze specifiche di ciascun partner.

Bibliografia

- [1] Ballesteros E., Torras X., Pinedo S., Garcia M., Mangialajo L., & De Torres M. (2007) - *A new methodology based on littoral community cartography for the implementation of the European Water Framework Directive*. Marine Pollution Bulletin, 55, 172-180.
- [2] Bressan G., Babbini L., Ghirardelli L., & Basso D. (2001) - *Bio-costruzione e bio-distruzione di Corallinales nel Mar Mediterraneo*. Biologia Marina Mediterranea, 8 (1), 131-174.
- [3] Legg C. J., & Nagy L. (2005) - *Why most conservation monitoring is, but need not be, a waste of time*. Journal Environmental Management, 78(2), 194-199. DOI: 10.1016/j.jenvman.2005.04.016
- [4] Mallet D. & Pelletier D. (2014) - *Underwater video techniques for observing coastal marine biodiversity: A review of sixty years of publications (1952–2012)*. Fisheries Research 154, 44-6. DOI: 10.1016/j.fishres.2014.01.019

- [5] Rende F. S., Irving A. D., Bacci T., Parlagreco L., Bruno F., Defilippo F., Montefalcone M., Penna M., Trabucco B., Di Mento R., & Cicero A. M. (2015a) - *Advances in micro-cartography: two-dimensional video mosaicing technique for seagrass monitoring*. Estuarine, Coastal and Shelf Science, 167, 475-486. DOI: 10.1016/j.ecss.2015.10.029
- [6] Rende F. S., Irving A. D., Lagudi A., Bruno F., Scalise S., Cappa P., Montefalcone M., Bacci T., Penna M., Trabucco B., Di Mento R., & Cicero A. M. (2015b) - *Pilot application of 3d underwater imaging techniques for mapping Posidonia oceanica (L.) delile meadows*. Int. Arch. Photogramm. Remote Sens. Spatial Inf. Sci., XL-5/W5, 177-181. doi:10.5194/isprsarchives-XL-5-W5-177-2015.
- [7] Tunesi L., Agnesi S., Di Nora T., & Mo G. (2008) - *La conservazione della biodiversità marina alla luce delle iniziative europee*. Biologia Marina Mediterranea, 15 (1), 463-472.

THE PRESSURES AND THE ECOLOGICAL QUALITY STATUS OF THE MARMARA SEA (TURKEY) BY USING MARINE MACROALGAE AND ANGIOSPERMS

Ergün Taşkın¹, İbrahim Tan², Orkide Minareci¹, Ersin Minareci¹,
Hakan Atabay², Çolpan Polat-Beken²

¹Manisa Celal Bayar University, Faculty of Arts & Sciences, Department of Biology,
Muradiye-Manisa, 45140, Turkey, ergun.taskin@cbu.edu.tr

²TÜBİTAK, Marmara Research Center, Environment and Cleaner Production Institute,
Gebze-Kocaeli 41470, Turkey

Abstract – Marine benthic macroalgae and angiosperms are proposed as one of the biological quality elements to assess the ecological quality status of transitional and coastal waters by the European Water Framework Directive (WFD, 2000/60/EC).

In the present study, the *Marine Floristic Ecological Index* (MARFEI) was tested to assess the impacts by using marine benthic macrophytes (macroalgae and angiosperms) and pressures by using the Macroalgae-Land Uses Simplified Index (MA-LUSI) in the Marmara Sea (Turkey). Sampling of benthic macrophytes was made from 0÷5 m depth at 29 different sites during the summer periods of 2017, 2018 and 2019. The study revealed good ecological status class (ESC) for 6 sites, moderate for 11 sites, poor for 8 sites and bad for 4 sites. MARFEI_{eqr} showed a negative linear relationship with the pressure index MA-LUSI.

Introduction

Marine benthic macrophytes (macroalgae and angiosperms) are proposed as one of the biological quality elements to assess the ecological quality status of transitional and coastal waters by the European Water Framework Directive [1]. Several macrophyte indices, i.e. the Ecological Evaluation Index [2, 3], the CARtography of LITtoral (CARLIT) [4], the Macrophyte Quality Index (MaQI) [5, 6], have been proposed for the Mediterranean Sea.

The Sea of Marmara being bordered by Turkish territory; displays both coastal and marine water features, connected to the Black Sea by the Istanbul (Bosphorus) Strait and to the Aegean Sea by the Çanakkale (Dardanelles) Strait. Recently, the *Marine Floristic Ecological Index* (MARFEI) has been proposed especially for the Marmara Sea (Turkey) for the ecological quality classification of coastal waters [7].

In the present study, the *Marine Floristic Ecological Index* (MARFEI) was tested to assess the impacts by using marine benthic macrophytes (macroalgae and angiosperms) and pressures by using the Macroalgae-Land Uses Simplified Index (MA-LUSI) in the Marmara Sea (Turkey).

Materials and Methods

Sampling of benthic macrophytes was made from 0÷5 m depth at 29 different sites during the summer periods of 2017, 2018 and 2019 as part of the national Integrated Marine Pollution Monitoring Programme (MoEU, Turkey) (Figure 1).

The material was collected by snorkeling from a 100 m x 100 m area per station [7], and specimens were preserved in 2÷5 % formaldehyde in sea water. Samples were studied using a light microscope (Nikon SE).

Physico-chemical parameters (salinity, temperature, pH, conductivity, turbidity, and dissolved oxygen), ortho-phosphate [8], and ammonium nitrogen [9] were also measured.

Land Uses Simplified Index (LUSI) is a method to assess the continental pressures (i.e. mariculture, sewage outfall, harbours, irregular fresh water inputs, sediment nutrient release, urban, commercial and industrial, agriculture) on coastal waters [10, 11]. This index has been developed by the Macroalgae Technical Group of the Mediterranean Geographical Intercalibration Group (MEDGIG), as called MA-LUSI (LUSI for shallow water macroalgal communities) [12].

Macrophytes (macroalgae and angiosperms) were classified into five ecological status groups: ESGI (IA, IB, IC; late-successional taxa such as *Cystoseira* spp., *Padina* spp., angiosperms, calcareous red algae, *Halimeda tuna*, etc.) and ESGII (IIA, IIB; opportunistic taxa such as filamentous *Ectocarpus* spp., *Ceramium* spp., *Cladophora* spp., and sheet-like green algae *Ulva* spp., etc.) [3, 7].



Figure 1 - Sampling stations in the Marmara Sea (Turkey). (1: Susurluk Ağızı; 2: Bandırma; 3: Kapıdağ; 4:Edincik; 5:Şarköy; 6: Tekirdağ; 7: Marmara Ereğlisi; 8: Küçükçekmece; 9: Tuzla; 10: Kavaklıdere; 11: Kaytazdere; 12: Hereke; 13: Yalova; 14: Armutlu; 15: Gemlik; 16: Yenikapı; 17: Silivri; 18: Karabiga; 19: Edincik-Enerji Sa; 20: Lapseki; 21: M. Ereğlisi-Batı; 22: B.Çekmece; 23: Kadıköy; 24: Değirmendere; 25: Eskihisar-MAM; 26: Çınarcık; 27: Mudanya; 28: Susurluk-Doğu; 29: Adalar-İstanbul).

Ecological Quality Ratio (EQR) between 0 and 1 was obtained by the formulation of MARFEI (bad=0÷0.20; poor=0.20÷0.40; moderate=0.40÷0.60; good=0.60÷0.80; high=0.80÷1) [7]. The relationship between pressures and MARFEI_{egr} values has been calculated using the MA-LUSI index.

Formula: $MARFEI_{egr} = (4*\%IA + 3*\%IB + 2*\%IC) / (1*IIA + 0,5*IIB)$.

Results

Physicochemical properties were found as average for three years in the coasts of the Marmara Sea as pH 8.28, temperature 26.17 °C, salinity ‰ 22.29, oxygen 5.84 mg/L, turbidity 2.51, conductivity 34739 µS, orthophosphate 3.56 µg/L, and ammonium nitrogen 34 µg/L. Phosphate was especially found as high in the monitoring sites Hereke, Gemlik, Kavaklıdere, Küçükçekmece, and these sites are affected by anthropogenic impact, and poor or bad ecological quality. The green algae *Ulva* and *Cladophora*, the red algae *Ceramium* and *Polysiphonia* are found dominantly. The highest value of ammonium nitrogen was measured in Kavaklıdere (97 µg/L).

The results of the pressures data (MA-LUSI index), MARFEI_{egr}, and ecological status class (ESC) of the sampling stations are given in Table 1. The study revealed good ecological status class (ESC) for 6 sites (Kapıdağ, Edincik, Şarköy, Edincik-Enerji Sa, and Marmara Ereğlisi-Batı), moderate for 11 sites (Bandırma, Tekirdağ, Marmara Ereğlisi, Yalova, Armutlu, Karabiga, Eskişehir-MAM, Çınarcık, Mudanya, Susurluk-Doğu, and Adalar-İstanbul), poor for 8 sites (Susurluk-Ağzı, Tuzla, Kavaklıdere, Kaytazdere, Yenikapı, Silivri, Kadıköy, and Değirmendere) and bad for 4 sites (Küçükçekmece, Hereke, Gemlik, and Büyükçekmece) (Table 1 and Figure 2).

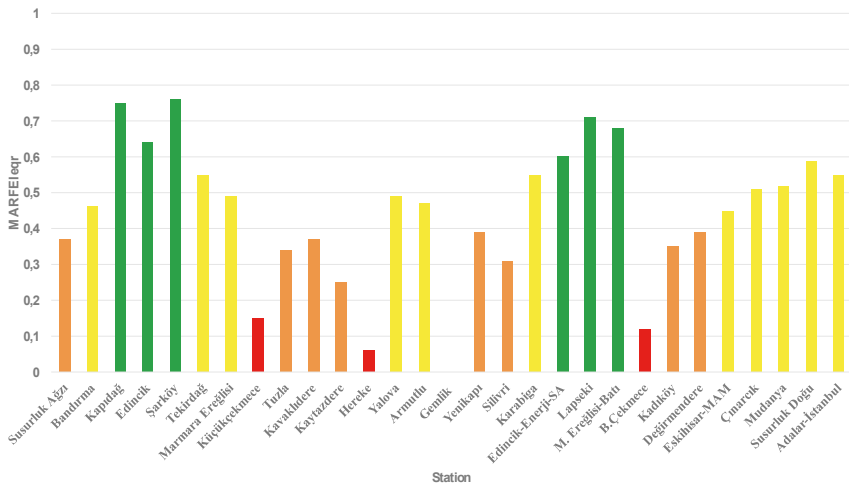

Figure 2 - The Ecological Quality Ratio (EQR) of the sampling sites in the Marmara Sea (Turkey) by the MARFEI index.

Table 1 - The Ecological Quality Ratio by MARFEI_{eqr}, ecological status class (ESC), and pressures data (MA-LUSI index) in the Marmara Sea (Turkey). (B: Bad, P: Poor, M: moderate, G: Good)

No	Station	MA-LUSI	MARFEI _{eqr}	Ecological status class (ESC)
1	Susurluk Ağzı	9	0,37	P
2	Bandırma	7,5	0,46	M
3	Kapıdağ	3	0,75	G
4	Edincik	3,75	0,64	G
5	Şarköy	4,21	0,76	G
6	Tekirdağ	5,25	0,55	M
7	Marmara Ereğlisi	3,37	0,49	M
8	Küçükçekmece	9,37	0,15	B
9	Tuzla	8,75	0,34	P
10	Kavaklıdere	6	0,37	P
11	Kaytazdere	6,25	0,25	P
12	Hereke	7	0,06	B
13	Yalova	7	0,49	M
14	Armutlu	3,75	0,47	M
15	Gemlik	10	0,00	B
16	Yenikapı	10	0,39	P
17	Silivri	10	0,31	P
18	Karabiga	3,75	0,55	M
19	Edincik-Enerji-SA	3,75	0,60	G
20	Lapseki	2,25	0,71	G
21	M. Ereğlisi-Batı	4,68	0,68	G
22	Büyükçekmece	10,93	0,12	B
23	Kadıköy	11,30	0,35	P
24	Değirmendere	8	0,39	P
25	Eskihisar-MAM	8	0,45	M
26	Çınarcık	4,5	0,51	M
27	Mudanya	8,75	0,52	M
28	Susurluk Doğu	9,37	0,59	M
29	Adalar-İstanbul	2,81	0,55	M

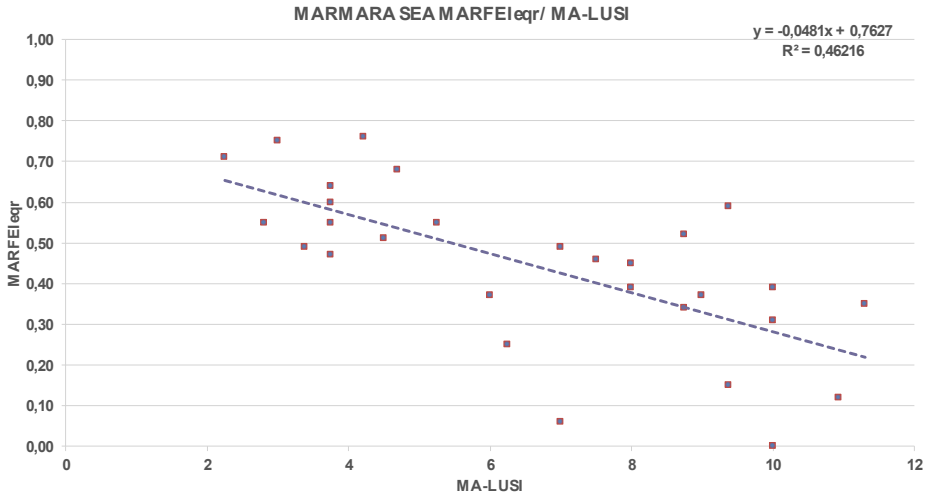

Figure 3 - Relation between the MARFEI_{eqr} index and pressure data (MA-LUSI index) in the Marmara Sea (Turkey).

The MARFEI_{eqr} index values and pressures data (with MA-LUSI index) was tested, and a negative correlation ($R^2=0.46$) was found between pressures and impacts in the sampling sites (Figure 3).

Discussion

The Marmara Sea is high marine traffic area moderately affected by anthropogenic disturbances (i.e. urban, industrial) [7]. The Marine Floristic Ecological Index (MARFEI) was proposed to assess the ecological status class of the coastal waters for the Marmara Sea in 2018, and 25 sites were studied, and the good ecological status class (ESC) for one site (İntepe), moderate for 11 sites (Eceabat, Şarköy, Marmara Ereğlisi, Üsküdar, Yalova, Armutlu, Mudanya, Erdek, Paşalimanı Island, Karabiga, and Lapseki), poor for 10 sites (Çanakkale, Gelibolu, Tekirdağ, Silivri, Küçükçekmece, Büyükçekmece, Gemlik, Susurluk River-Boğaz, Princes Islands, and Bandırma) and bad for 3 sites (Kocaeli, Hereke, and Haliç) were classified by MARFEI [7]. In the present study, six sites (Kapıdağ, Edincik, Şarköy, Edincik-Enerji Sa, and Marmara Ereğlisi-Batı) are found as the good ecological status class.

Recently, the Ecological Evaluation Index (EEI-c) was tested to assess the impact by using marine benthic macrophytes (macroalgae and angiosperms) in the Turkish marine waters, and the sampling was made from 56 stations which are 15 stations from the Marmara Sea [13]. In the study, revealed high ecological status class (ESC) for one site (Şarköy), good for 5 sites (Kapıdağ, Edincik, Tekirdağ, Armutlu, and Marmara Ereğlisi), moderate for 2 sites (Yalova, and Kaytazdere), poor for 6 sites (Susurluk-Ağzı, Bandırma, Küçükçekmece, Tuzla, Kavaklıdere, and Gemlik) and bad for one site (Hereke) [13]. Because of the sampling effort

of the two indice (MARFEI and EEI-c) in the same time, the results of the present study are similar to EEI-c results.

Conclusion

The Marine Floristic Ecological Index (MARFEI) can be used to assess of the ecological status class (ESC) of the coastal and transitional waters in the Marmara Sea (Turkey). However, MARFEI is a destructive method to assess of the ESC, and it is needs more time to describe the taxa, and need experts.

Acknowledgements

The present study, was carried out with the project called “Integrated Pollution Monitoring in Turkish Seas (ÇŞB/ÇEDİDGM-TÜBİTAK/MAM; 2017-2019)” supported by the Ministry of Environment and Urbanization of Turkey.

References

- [1] EU (2000) - *DIRECTIVE 2000/60/EC of the European parliament and of the council, of 23 October 2000, establishing a framework for Community action in the field of water policy*, Official Journal of the European Communities, G.U.C.E. 22/12/2000, L 327.
- [2] Orfanidis S., Panayotidis P., Stamatis N. (2001) - *Ecological evaluation of transitional and coastal waters: A marine benthic macrophytes-based mode*, Mediterranean Marine Science 2, 45-65.
- [3] Orfanidis S., Panayotidis P., Ugland K. (2011) - *Ecological Evaluation Index continuous formula (EEI-c) application: a step forward for functional groups, the formula and reference condition values*, Mediterranean Marine Science 12, 199-231.
- [4] Ballesteros E., Torras X., Pinedo S., García M., Mangialajo L., de Torres M. (2007) - *A new methodology based on littoral community cartography dominated by macroalgae for the implementation of the European Water Framework Directive*, Marine Pollution Bulletin 55, 172-180.
- [5] Sfriso A., Facca C., Ghetti P.F. (2007) - *Rapid Quality Index, based mainly on Macrophyte Associations (R-MaQI), to assess the ecological status of the transitional environments*, Chemistry and Ecology 23, 1-11.
- [6] Sfriso A., Facca C., Ghetti P.F. (2009) - *Validation of the Macrophyte Quality Index (MaQI) set up to assess the ecological status of Italian marine transitional environments*, Hydrobiologia 617, 117-141.
- [7] Taşkın E., Tsiamis K., Orfanidis S. (2018) - *Ecological quality of the Sea of Marmara (Turkey) assessed by the Marine Floristic Ecological Index (MARFEI)*, Journal of the Black Sea/Mediterranean Environment 24(2), 97-114. 
- [8] Parsons T.R., Maita Y., Lalli C.M. (1984) - *A Manual of Chemical and Biological Methods for Seawater Analysis*, Pergamon Press, Pons Point, N.S.W. Australia.

- [9] Strickland J.D.H., Parsons T.R. (1972) - *A Practical Handbook of Seawater Analysis*. Fisheries Research Board of Canada, The Alger Press, Ottawa, Canada.
- [10] Flo E., Camp J., Garcés E. (2011) - *Assessment Pressure methodology, Land Uses Simplified Index (LUSI)*, (Personal communication WFD-CIS- phase II, Technical paper).
- [11] Flo E., Garcés E., Camp J. (2019) - *Land Uses Simplified Index (LUSI): Determining Land Pressures and Their Link With Coastal Eutrophication*, *Frontiers in Marine Science* 6, 10.3389/fmars.2019.00018.
- [12] EC (2013) - *Commission Decision of 20 September 2013 Establishing, Pursuant to Directive 2000/60/EC of the European Parliament and of the Council, the Values of the Member State Monitoring System Classifications as a Result of the Intercalibration Exercise and Repealing Decision 2008/ 915/EC*, Official Journal of the European Union (L 266/1-47).
- [13] Taşkın E., Tan İ., Minareci E., Minareci O., Çakır M., Polat-Beken Ç. (2020) - *Ecological quality status of the Turkish coastal waters by using marine macrophytes (macroalgae and angiosperms)*, *Ecological Indicators* 112, 106107.

SESSION

**COASTAL ENVIRONMENTAL ENGINEERING:
POLLUTION, ENERGY PRODUCTION,
MONITORING AND ECONOMIC
ENVIRONMENTAL ASSESSMENT,
REGULATORY CONTEXT**

Chairman: Marcantonio Catelani
Department of Information Engineering
University of Florence

COASTAL ENVIRONMENTAL ENGINEERING: POLLUTION, ENERGY PRODUCTION, MONITORING AND ECONOMIC ENVIRONMENTAL ASSESSMENT, REGULATORY CONTEXT

The coastal environment represents a complex natural context characterized by the interaction of many different factors, often heterogeneous. In this particular context a wide variety of disciplines and research activities are involved in order to study different phenomena and give solutions. Engineering science contributes in a wide field such as pollution, energy production, monitoring and economic environmental assessment, regulatory context. For each mentioned field different approaches, design, monitoring activities, assessment criteria and economic evaluations can be then proposed and implemented. It is important to underline that, from the engineering point of view, particular attention must to be done to national and international reference regulatory framework. This session, with title *Coastal Environmental Engineering*, aims to study these aspects and includes topics as: plants and techniques for purification and desalination of water; systems and techniques for coastal and marine energy production; systems, sensors and instruments for measuring environmental parameters; techniques and procedures for coastal monitoring; evaluation of the reliability and performance of measurement systems; information acquisition systems and data for the coastal environment; economic assessments in the construction and management of plants; impact analysis of new production plants energy on local economic systems and climate change gas emission; analysis of the reference regulatory framework.

This is the main reason considered by the Organizing Committee to propose this technical Session that saw a large participation as a whole, with works presented by qualified Research Units variously distributed nationally and internationally, demonstrating a shared and widespread interest on the above mentioned topics.

In practice, many interesting contributions has been proposed by Authors. As below, some of them focus on measurement system and instrumentation, other take into account pollution. Important considerations are made considering the regulatory framework in particular context. The contributions received in this regard are manifold and of considerable scientific interest, also due to the transversal nature that the topics covered in some of them cover in the broad theme of the Symposium.

- The paper *Renewable power sources in coastal areas a viability assessment in the scope of needs and regulations* proposed by A. Bono, University of Genova, and M. Marini from University of Sassari deals with renewable energy projects in the context of the evolution of the deregulated energy market. A fundamental aspect taken into account by Authors in this paper concerns renewables and the actual situation in Italy from the standards and regulations point of view, in terms of promotion and incentives granted to renewable power plants for a wider development of them. Details concerning economic aspects are also proposed.

- M. De Vincenzi and G.Fasano from CNR Institute of BioEconomy in Florence present the paper *Monitoring coastal areas: a brief history of measuring instruments for solar radiation*. As said by Authors, the first references to the concept of solar radiation are due to Aristotle. Nowadays, the measurement of Solar radiation is a fundamental topic and sophisticated instruments and measurement process are implemented during the years. Among the last developments, a wide range of sophisticated electronic radiometers are designed and produced with interesting measurement performance in terms of resolution, accuracy and precision. At the same time, complex monitoring system need to realize in order to control climatic phenomena in real time. Authors conclude the presentation speaking about the recent developments of radiometric measurements for research in marine and coastal environments and for studies on the effects of the various components of solar radiation on human health.
- The continuous increase in maritime traffic of goods and people over the years, both by ferries and cruises, highlights the problem of environmental pollution in port areas, especially when the port is located in proximity of urban areas. D.Colarossi and P.Principi from the Università Politecnica delle Marche underline these aspects in *Feasibility study of a cold ironing system and district heating in port area*. Cold ironing strategy is considered in order to satisfy the electrical power demand of ships while they are at berth replacing on board diesel generators. In particular, a detailed analysis of the electrical loads required by the ships while they're at berth is presented, as well as a correlated economical evaluation that prove the feasibility of the proposed system.
- Yet referred to economical and environmental evaluation of pollution regarding an important coastal site in Molise is the paper *The economic-environmental impact analysis in the choice of the management of the dredging materials of a port basin in relation to their classification and quality: the experience of the port of Termoli (2018)*. A.Cioffi, F.Cuculo, L.Di Nucci and G.Orlando shows the comparison of the economic and environmental impact analysis in a study case: "Dredging work on the seabed of the port of Termoli 2018", taking into account the Ministerial Decree 173/2016 regarding *ecotoxicological characterization of the sediments of the dredging area and of the diving area led*. The study aims to evaluate the pollution level of dredging materials in Termoli port for the consequence location, of such materials, in open sea. From the result of this study, on the basis of the national regulation, Authors conclude that, according to the monitoring studies (led by Arpa Molise) and the into force regulations of November 2015, the totality of materials coming from the Termoli's harbor dredging could be immersed in a compatible area chosen in open sea.
- The paper "*Flex 2018*" *Cruise: an opportunity to assess phytoplankton chlorophyll fluorescence retrieval at different observative scales*, proposed by A. Di Cicco et AL., speak about the oceanographic cruise "FLEX 2018", organized by CNR with the aim to contribute to calibration/validation activities for existing and future space mission developments. The main topic concerns in situ measurements of Solar Induced Fluorescence (SIF) and the use of different instruments. In particular, as said by Authors, active and passive fluorescence were investigated at different scales in aquatic

ecosystems, to support preparatory activities of the FLuorescence EXplorer (FLEX) satellite mission to be launched in 2022.

- J.Droit from CEREMA, France, presents the paper *Careening areas in marinas, anchorages, and private shipyards. Status of implementation of the MSFD measure*. The paper considers the impact, from the pollution point of view, of the stripping process of ship careening and the use of antifouling paint. In particular, the presence of waste, in the form of dust or flakes, which can contaminate the marine environment by runoff or by air is taken into account. This process, necessary for the maintenance of the careen, can be polluting for the presence of chemical contaminants (biocides, hydrocarbons, microplastics, solvents ...) that can have an impact on the environment and human health. The goal was to carry out a national study identifying the level of equipment in fairing areas of marinas, anchorages and private shipyards to assess their respect for the environment. To this aim a survey was implemented in order to check the impact of the process.
- The presence of some elements such as nitrogen, phosphate and silicon have an impact in the planktonic primary production. Consequently, it is fundamental to check such elements in the sea, above all in particular morphological conditions. F.Figueroedo et Al. considers this topic in the paper *Electrochemical phosphate detection in oligotrophic seawater with a stand-alone plastic electrode*. The study was implemented in the northern Adriatic Sea, that is particular water system in which the levels of nutrients are commonly low or unbalanced with an abundance of nitrogen. As alternative to classical approaches that are present in literature for detecting nutrients, Authors propose a new method based on the application of a plastic conductive electrode containing a molybdenum reagent embedded. Authors demonstrate good performance in terms sensitivity for phosphate detection using the proposed measurement system.
- The study presented by N.Ghirardi et Al. is focused on the use of satellite remote sensing to map coastal erosion vulnerability in two Italian sites: Pianosa Island (Tuscany) and Piscinas (Sardinia). In the paper *Mapping of the risk of coastal erosion for two case studies: Pianosa island (Tuscany) and Piscinas (Sardinia)*, Authors focuses the attention on the land/water transitional ecosystem, with the aim of identifying potential coastal erosion phenomena. In this research the remote sensing data was used, as acquired by the Multispectral Imager (MSI) on-board of Sentinel-2A (S2). The research theme concerning the beach and dunes volume changes has been integrated by COSMO-SkyMed SAR data acquired over repeated orbits. As conclusion, Authors affirm that the use of multi-source remote sensing satellite data allowed to contribute to the assessment of the phenomenon of coastal erosion phenomenon, offering a new perspective and allowing to overcome some limitations associated with field surveys. In addition, as concluded by Authors, the dedicated processing and the use of physically based algorithms provided reliable results, although further activity seems necessary to validate the satellite-inferred maps.
- In the contribution proposed by P.Ventura and M.Palmarocchi the synergy between the coastal protection and energy production with vertical turbine is presented. The paper

New coastal protection and sea energy production takes in consideration the benefit of Turbine barrier location as a system able to transform the energy of the vertical pulsating waves (offshore) into horizontal sea currents (inshore). The advantages of such system can be reach in a soft defense of the coast in alternative to the traditional rigid defense obtained with rockfill, piers, etc. At the same time, in addition to a reduction of erosion, the electricity production by turbine is possible.

As conclusion, after this brief presentation of the papers, we can say that the wide and varied works proposed by the researchers for this Session is a valid demonstration on the high interest for the Coastal Environment. Many open points are present, many further developments are proposed by Authors, demonstrating the fact that the environmental engineering and physics need to research activities able to study complex phenomena.

Marcantonio Catelani
Department of Information Engineering
University of Florence
Email marcantonio.catelani@unifi.it

RENEWABLE POWER SOURCES IN COASTAL AREAS A VIABILITY ASSESSMENT IN THE SCOPE OF NEEDS AND REGULATIONS

Andrea Bono¹, Martino Marini²

¹ DIME, Università di Genova, andrea.bono@edu.unige.it

² DADU, Università di Sassari, marini@uniss.it, tel.079-9720409, fax 079-9720420

Abstract – The work deals with renewable energy projects, in the context of the evolution of the deregulated energy market. Special attention is focused on renewables and on the actual situation in Italy from the standards and regulations point of view, in terms of promotion and incentives granted to renewable power plants for a wider development of them. The goal is the targeted level of energy production to be extracted from renewable power, as it has been stated by European Countries' agreements. The installation of a wind farm in a coastal Sardinian area is investigated in view of both electricity and desalinated water production. The convenience of fuelling desalination plants through renewables is investigated by taking into account additional on-side trading instruments such as green certificates, mandatory quota of renewables to be satisfied by energy operators and convenience to fulfill the renewable obligation by the acquisition or by the trading of certificates. A model to simulate the operation of a renewable energy plant is applied to assess the performance of a desalination plant based on a reverse osmosis technology (RO) and driven by wind systems. The economic performance is assessed for a possible installation in Sardinian sites with critical water and energy needs, focusing the attention on the dispatching regulatory policy.

Introduction

Water and energy are essential entities for any thriving life and civilization. The water and energy shortages have arisen in various parts of the world due to a dramatic growth in the population, standards of living, and the rapid development of agricultural and industrial sectors. Desalination appears one of the most promising solutions to the water problem; however, it is an intensive energy process. The integration of renewable energy into water desalination systems is getting increasingly attractive due to an overall growing water and energy demand, and to a required reduction of contributions to the carbon footprint. The economic performance of the RED (Renewable Energy Desalination) systems is difficult to be assessed and its comparison to conventional systems is not conclusive due to the many varying factors involved, which are related to the level of technology, the availability of the energy source, and the government subsidizations.

Desalination is the process consisting in removing dissolved salts and minerals from saline water to produce drinking water, where saline water is classified on the basis of the Total Dissolved Solids (TDS) which are up to 10000 ppm for brackish water, and up to 45000 ppm for seawater. Desalination is characterized by a quite long historical development and some desalination technologies are still under development such as: solar chimney, greenhouse, natural vacuum, adsorption desalination, membrane distillation, membrane bioreactor,

forward osmosis, and ion exchange resin. The western and developed countries prefer RO (Reverse Osmosis) systems because of its low power consumption, while the Middle East and Gulf countries prefer MSF (Multistage Flashing) and MED (Multi-Effect Distillation) systems on account of a large availability of the oil source. The simplest desalination technology is the Solar Still Distillation (SSD) system, which is a key example of a renewable desalination system; it is viable to be set up in remote sites with a small water demand due to its intrinsic low productivity.

Energy requirements for desalination have severely decreased over the last 40 years and are expected to keep reducing, due to technological improvements. Many factors affect the energy required in desalination: enhanced system design, high efficiency pumping, energy recovery, advanced membrane materials and innovative technologies. The amount of conventional energy required by a successful conventional desalination process makes the need of redirecting to renewable and sustainable energy resources a truly self-evident step forward. Both electrical and thermal energy consumption have to be taken into account, the latter more correctly in terms of electrical equivalent for thermal energy. The energy requirements range from 3 to 25 kWh/m³ depending on many factors, anyway accounting for a decrease in sustainability of desalination plants in spite of their above discussed technological improvements as the produced fresh water increased by 30 % from 2011 to 2015.

The RED systems are experiencing an increasing interest worldwide; solar, wind, geothermal, wave and tidal energy are the main sources as well as hydropower and biomass energy. Solar energy is the most eligible source of renewable energy to be integrated with desalination systems because it can produce both the heat and the electricity needed by all of the desalination processes. Photovoltaic, linear Fresnel, parabolic trough, and central receiver are the main technologies effective to exploit the solar source. Currently, about 70 % of renewable desalination plants is fed by solar energy. However, collecting solar energy requires large land areas whose economical value may prove unsteady from the market point of view and may be used for other purposes. Wind energy, more suitable to the coastal areas where the wind and water are available and often plentiful, is mostly combined with RO desalination systems because they require just electricity. Geothermal energy exploits the high temperature of the earth's subsoil to produce steam or to store the heat energy. Wave and tidal energy are also suitable to the coastal areas and a commercial-scale wave energy system was recently installed in Australia [1].

The present installed desalination capacity by RE is negligible compared to the world's total capacity. Worldwide, several small-scale RE-driven desalination plants have been installed and most of them successfully operated and proved that they need simple maintenance. However, a major goal is to detect and assess RE sources as a precondition to satisfy the ever growing demand for freshwater in a sustainable way with a special attention to regions plagued with water scarcity. Solar, and possibly Geothermal Energy (GE) could be a good alternative source because they are steady, largely available and environmentally friendly. However, most of the installed desalination plants are connected to a grid from which they are sometimes fed, i.e. for compensation.

At present, resorting to renewable energy sources in desalination systems is inconvenient compared to making use of fossil fuel because of the high cost of collecting these renewable sources and the related requirements of considerable levels of technology and infrastructure. Although renewable desalination systems cannot currently compete with conventional technologies in terms of the cost of water produced, they prove a competitive

choice for remote and arid areas and could represent a feasible solution on a large scale in the near future.

There are no significant technical obstacles in combining RE and desalination technologies; the most frequently used combination is PV with RO. Since heat losses are more significant in small thermal distillation units, large sizes are more attractive for them. The main limitation in using PV technology for water desalination is the high cost of PV cells. According to a number of studies production costs for PV cells industry will continue to fall. The majority decrease in these costs will be a consequence of technology innovations such as diamond wire sawing for PV wafers, advanced metallization solutions, and increased automation as opposed to manual labor. As a consequence, in the near future PV technology can be expected to compete with conventional resources [2].

A Concentrating PhotoVoltaic (CPV) system operates in the same way that conventional PV technology does, apart from that it uses optics to concentrate the sun onto solar cells that do not cover the entire module area. Traditional PV systems utilize large amounts of silicon solar cells, on the contrary CPV systems utilize a small amount of high efficiency solar cell material. However, CPV modules must accurately face the sun, so that they are used in conjunction with high-performance trackers that intelligently and automatically follow the sun throughout the day with the goal of keeping the focal point on the cell as the sun moves across the sky.

The greenhouse is a versatile system that can be implemented to water desalination. The seawater greenhouse exploits sunlight, sea/brackish water, and the atmosphere to produce freshwater and cool air, creating more comfortable conditions for the cultivation of crops. The process recreates the natural hydrological cycle within a controlled environment. Two humidifiers that consist of a cardboard honeycomb lattice produce humidified air at saturation point which are useful to keep the greenhouse cool temperature while allowing the crops to grow in high light conditions. Air at saturated conditions leaving the evaporator passes over the condenser, and the freshwater condensing from the humid air is characterized by overall zero salinity. This water is pumped to the storage tank for irrigation. The system has several advantages in terms of flexibility in capacity, moderate installation and operating costs, simplicity and possibility of exploiting RE (solar, wind and geothermal energy).

Desalination is responsible for environmental impacts to be understood and mitigated. The greenhouse gas emissions associated with fossil fuel energy sources for desalination can be highly reduced by exploiting renewable energy sources such as solar PV, solar thermal, wind or geothermal energy sources and also by reducing the total energy requirement of the process. Moreover, the process drains off large amounts of water from the sea by means of an intake, whose action can be direct (open water) or indirect (subsurface). Desalination plants extracting water directly from the ocean through open water intakes have an immediate impact on marine life: marine life is killed on the intake screens and organisms small enough to pass through the screens, such as plankton, are killed during the process. Physical barriers (such as barrier nets, travelling screens, wedgewire screens) and behavioral deterrents (such as air bubble curtains, strobe lights, sound generators or velocity caps) are available to reduce the environmental impact of a seawater intake. Alternatively, a small number of desalination plants presently starts to use indirect intakes. Their advantage resides in eliminating the impact on marine life while also reducing pre-treatment requirements but on the other hand their weak point is a higher construction cost and complex survey methods [3].

Furthermore the desalination process produces high salinity water (concentrate or brine), which includes salts and chemicals utilized during the desalination process, mainly at the pre-treatment stage. The brine's concentration depends on the type of desalination process used, and the temperature of the brine is higher than the original feed water, in the case of thermal desalination. In membrane desalination this difference is usually lower than 1 °C. There are various options to dispose of the concentrate: surface/submerged discharge; sewer system blending at a waste treatment process; land application; deep well injection in non-drinking aquifers; evaporation ponds and finally zero liquid discharge which is a technique to solidify liquid concentrate and to put it in a landfill. To select the method, various factors must be considered: volume of concentrate; quality of concentrate constituents; geographical location of discharge point; availability of receiving site; permissibility of the option; public acceptance; capital and operating costs; and expandability capacity. However, over 90 % of large plants currently in operation get rid of brine through a sea discharge by means of several methods in order to disperse the concentrated brine, such as multi-port diffusers placed on the discharge pipe to promote mixing. In addition to this, desalination plants typically dilute the brine by increasing the intake of sea water or by mixing it with other sources such as cooling water from an adjacent power plant or a wastewater effluent. The salt and chemicals contained in the brine could potentially be utilized to manufacture products such as: paper, ink, plastics, fertilizers, soil conditioners, etc.; the technical and economic feasibility of such solutions remains to be demonstrated.

The technological feasibility of desalination coupled to renewable energy technologies depends on local availability of renewable energy sources, but also on connections to the transmission grid, characteristics of the power plant for regulations matching, actual law in force and incentivizing policy, scheduled lifetime of the system. Promotion and incentives granted to renewable power plants are illustrated as well as the legislative context granting facilitations for renewable plant investors and operators. The energetic and economic performance is assessed for a possible installation in Sardinian sites with particular and critical water needs focusing the attention on the dispatching regulatory policy.

Materials: incentives to renewable energy sources

Incentives to renewable energy sources date back to 1999, when the obligation was introduced, as from 2002, for non-renewable power producers to inject into the electrical grid a fixed electrical energy quota from renewables, to be increased on an annual basis. Incentivization was promoted by the Green Certificate mechanism (GC); renewable power producers obtained GCs for their renewable production and GCs could be used and traded to fulfill the obligation stated by the above-mentioned law of 1999, in addition to the common power selling. A legislative decree in 2011 has determined the gradual substitution of the GC mechanism by a *feed-in tariff*, followed by another L.D. in 2012 defining the new incentivization policy. In order to obtain GCs and incentives, a power plant must be qualified as a renewable power plant. In such a context the Energy Service Manager (ESM, it. GSE, *Gestore dei Servizi Energetici*) is the electrical system operator for proceedings regarding qualification requests and emissions of certificates, to get access to any form of renewable incentivization [4].

With the new incentivization, called *All-Inclusive Feed-in Tariffs* (AIFTs, it. *Tariffe Onnicomprensive*) renewable electrical energy is collected by the ESM and remunerated,

accounting for both a quota due to the incentivizing policy and another quota due to the selling to the market. The *Simplified Purchase and Resell Agreement* mechanism (SPRA, it. *Ritiro Dedicato*), regulated by the Electrical Energy and Gas Authority (EEGA, it. AEEG, now changed to ARERA), is a simplified form of energy selling by which the producer is saved from a direct operation on the Italian Power Exchange (IPE, it. *Borsa Elettrica*). Otherwise a *Power Purchase Agreement* contracting (PPA, it. *Contratto Bilaterale*) is viable, an indirect form of selling executed by the Energy Market Manager (EMM, it. GME, *Gestore dei Mercati Energetici*), at the market zonal price of the electrical region where the power plant is located. The *Net Metering* mechanism (NM, it. *Scambio sul posto*), regulated by the EEGA, operative from 2009, is an economical reward of the difference between the value of the electrical power at the moment of injection into the grid and its value when absorbed from the grid.

L.D. 28/11 stated a gradual substitution of GCs by a *feed-in tariff*. GCs have been maintained or substituted according to the date of commission to service of the power plant and the produced energy amount. As from 2016 the GC mechanism has been passed over and the new incentivization is operational. Economic incentive is granted by M.D. 23/06/16 to renewables, on specific request evaluated by the ESM. Renewables newly commissioned or subject to rebuilding or repowering are differently incentivized: small units may ask for incentives through a direct request within Dec. 31st 2017; medium units must be registered in a renewable power plant book to be assigned to a pre determined incentive-open power quota; large units must enter a renewable power plant Bearish Auction (it. *Procedura Competitiva di Asta al Ribasso*) for a pre-determined incentive-open power quota.

The present incentivizing benefit for renewable power plants is limited to: tax discharge (nearly 50 % deducibility on the investment costs); surplus power reselling to the grid; NM mechanism access; SPRA mechanism access.

NM is a particular form of self-consumption of electrical power: the electrical power producer injects into the electrical grid a surplus of electrical power not directly absorbed by itself, and collects it back during a subsequent time frame, with no electrical power production. It grants the electrical producer to gain the economical compensation between the value of the electrical power when it is injected into the grid and the value of the same power when it is absorbed from the grid.

Electrical power plants that benefit from incentives granted by M.D. 05/07/12 and M.D. 06/07/12 cannot enter the NM mechanism. The ESM pays to the customer the due amount for the NM contract, with by two components: 1) amount for *Net Metering Account*, 2) any energy surplus, if the grid-injected energy is greater than the grid-absorbed energy.

The SPRA is a particular form of selling electrical to the electrical grid: renewable producers can choose this option as an alternative to a direct selling into the electrical market through the IPE or the PPAs. The produced electrical energy collected by the ESM grants a defined price per generated kWh unit. The revenues earned through the SPRA may be cumulated with any other incentive to renewables, except the AIFIT. The ESM collects renewable energy and resells it on the IPE and acts as an user of the electrical system with regard to dispatching and transport. The SPRA is reserved to power generation plants fed by renewables or conventional non-renewables characterized with: 1) nominal apparent output lower than 10 MVA (production of hybrid power plants included); 2) nominal apparent output lower than 10 MVA (conventional non-renewables, non-imputable production of hybrid power plants included); 3) nominal apparent output equal or higher than 10 MVA (renewables – different from wind, solar, geothermal, wave, tidal, hydro

steady flow – owned by a power producer to satisfy its own electrical needs); 4) no limit (defined as renewables: wind, solar, geothermal, wave, tidal, hydro only steady flow) [4].

Energy Storage Systems (hereinafter referred to as ESS) may be coupled to renewable power plants in order to store energy, either absorbed from the grid or produced, and then continuously transfer it to the passive user or to inject it again into the grid. The implementation of such a storage system significantly alters the usual load profile of the absorption/injection point. ESS are allowed for renewables, with a tax amount due to the ESM for the configuration change (no tax below 3 kW) different according to the source and the power level. A formal authorization is required after the verification procedure, because of the critical modification of the usual load profile at the absorption/injection point. ESS are coupled to renewable power plants in accordance to Italian regulations with regard to the storage system charge type and electrical scheme. Configurations with reference to the charge flow to the ESS are: 1) one-way ESS can be charged only by the power plant; 2) two-way ESS can be charged both by the power plant and by the electrical grid. Configurations with reference to the positioning of the ESS are: 1) production-side ESS: placed at the DC output before the inverter, or at the AC output, between the power plant and the produced electrical energy metering device; 2) post-production-side ESS: placed between the produced electrical energy metering device and the net metering device. The admissible configurations are: one-way/production-side; two-way/production-side; two-way/post-production-side.

Methods: case study for desalination and wind energy

An eligible location for a hybrid desalination power plant is the Asinara Island close to north Sardinia, the entire surface and coastal area of which is a national park since 2002. The features of the water needs and management have been discussed and the site characteristics have been thoroughly investigated in previous works [5]. Particular attention was paid on environmental constraints and fluctuating water needs for the small island. The hybrid RO desalination process coupled with renewable sources as sun or wind has been analyzed in some details, along with the RO and wind/PV plants, reporting technical specifications and energy requirements [4, 5]. Here a new approach is proposed along the lines of that, focusing the analysis to wind energy.

Updated site wind data have been collected (EU Science Hub, IRENA International Renewable Energy Agency), consisting in data series covering multiple years (wind speed and wind direction over 8760 hours per year). Wind data have been smoothed for mean values and extrapolated at a 50 m hub height, taken as a standard level for commercial wind turbines. Fig. 1 shows wind speed on an hourly basis for a standard year (Jan-Dec). The size of wind turbines cannot exceed a medium value and the number of units in the wind farm is limited as well because of the site environmental constraints.

Water is needed to fill up storage reservoirs: rainfall values obtained from the meteorological database data.org and data obtained from the close-by municipality of Stintino, as well as the surfaces of the four catchment basins and their runoff coefficient, have been used in order to evaluate the global amount of storable water. Under the assumption of a system capable of ensuring a total balance of energy resources and water needs, and the assumption of a full water availability in the reservoirs (with an established maximum emptying limit equal to 70 % of their full level), a water shortage in summer

months is expected. This shortage can be balanced out by a sea water desalination plant sized accordingly to it. Its energy consumption, including pumping energy in the interconnection lines, has been evaluated with specific reference to the summer period when its operation is needed. Peak mean power for empowering the RO system has been evaluated on a monthly basis (Fig.2), showing a clear top. The performance of the RO plant was obtained through a Matlab code, based on the mathematical model by Avlonitis [5].

Several WT models and wind farm layouts have been tested in order to select an optimum configuration, able to grant desalination design load match in June-August months (Fig. 2), at a safety design point (electrical losses and auxiliaries included), equal to 100 kW_{el}, fed up by the poor wind speed characterizing critical summer months (nearly 4÷5 m/s). Optimal wind farm design has been set through a 4 unit in-line row configuration (WT model: Enercon E40; rated power: 550 kW at 12.0 m/s wind speed; 3 bladed rotor, diameter 40 m); total wind farm installed power: 2000 kW, in-line WT distancing: 8 WT diameters. Optimal rotor orienting is 110° in accordance to capacity factor¹ evaluation vs. different orientation angles (Fig. 3). The design choice is therefore a wind prime mover coupled to the desalination plant, which may be able to anyhow meet the RO load at its peak working condition during summer months, and so always granting a full power supply to the RO system. The wind farm's characteristic is a high electrical generation excess capability (exploitable when the wind potential is higher during the remaining months): any excess electrical energy may be sold on by injecting it into the interconnected electrical grid of the island. No ESS is introduced for cost reasons. The financial model assumed for this approach is a SPRA (*Simplified Purchase and Resell Agreement*), through which the produced electrical energy is collected by the ESM that grants a defined price per generated kWh unit. SPRA access conditions are met for the hybrid power plant under analysis [4].

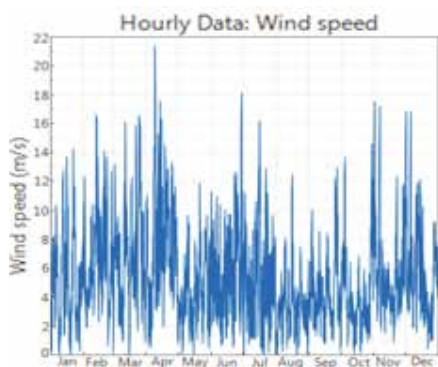

Figure 1 - Asinara site. Wind speed spectrum over 8760 hours. Values at 50 m (wind turbine hub height).

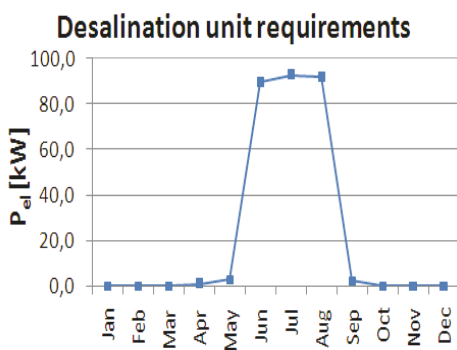

Figure 2 - Desalination unit electrical power absorption [4, 5]. Summer peak load.

¹ CF = Net Annual Energy [kWh_{AC}/yr] / System Capacity (kW_{AC}) / 8760 (h/yr). The capacity factor (CF) is the ratio of the system's electrical energy in the first year of operation to the nominal energy output (energy generated if the system would have been operated at its nominal power for every hour of the year).

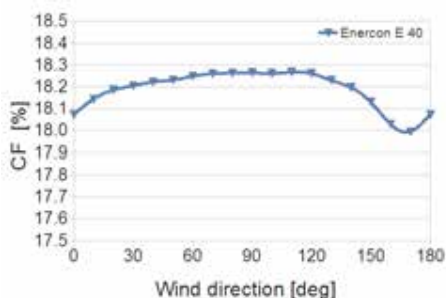

Figure 3 - Hybrid power plant: wind section. Capacity factor of Enercon E40 wind farm layout. 4 in-row WT units.

Table 1 - Hybrid system. Capital costs and O&M costs.

	Enercon E 40 [€/kW _{wind}] (*)
Wind power group	
Capital cost	1818 (2000 ²)
O&M cost	45(50 ³)
Desalination group	
CAPEX cost	7269 (7996 ⁴)
OPEX cost	27 (30 ⁵)
Hybrid power plant (wind + desalinat.)	
Capital cost	9087 (9996 ⁶)
O&M cost	73 (80 ⁶)

(*) \$/kW_{wind} value at current mean EUR/USD change equal to 1.1

Table 2 - Financial assumptions.

Financial analysis parameter	Value
Analysis period	20 yrs
Inflation rate	2.5 %
Project term debt	0 %
Nominal debt interest rate	0 %
Depreciation schedule	5-yr MACRS
Incentive	50 % capital cost
Incentive type	tax credit

Table 3 - Total costs.

	Wind section	Hybrid power plant (wind+desalin.)
Capital cost [€]	3636364	19992000
Capital cost [\$]	4000000	18174545
Fixed operat. cost [€/yr]	90909	145455
Fixed operat. cost [\$/yr]	100000	160000
Var. operat. cost [€/kWh]	-	-
Var. operat. cost [\$/kWh]	-	-

Wind power costs are evaluated and split under *capital costs* and *O&M costs* [6-8]. Desalination costs are split in *CAPEX costs* (*Components of Associated Capital Cost*, i.e. intake, pretreatment, desalination system, post-treatment, water storage & distribution, electrical & instrumentation, civil, misc. eng. & develop., etc.) and *OPEX costs* (*Operation and Maintenance Cost*, i.e. power; membrane & cartridge filter; solid waste; chemicals; maintenance, labor, etc.). Current CAPEX [9,10] and OPEX values [11-13] have been analyzed and evaluated for the designed power and desalination capacity (430 m³/d)² [4, 5]. Table 1 summarizes related results.

Financial assumptions are reported in Table 2 and total installation and operational costs are reported in Table 3. A standard 20 years period has been simulated and a depreciation 5-yr MACRS³ model has been assumed for the hybrid system. Absence/presence of incentive (investment tax credit) equal to 50 % of capital costs are assumed, variable operational costs are considered as negligible out of simplicity.

Simulations have been carried out through NREL SAM modelling environment, in order to evaluate LCOE (Levelized Cost of Energy) and SPRA (Simplified Purchase and Resell Agreement)⁴ pricing at different expected IRR (Internal Rate of Return) of the project. The IRR is a metric used in capital budgeting to evaluate the profitability of projects or investments. It estimates a project's rate of return, which indicates the project's

² Desalination costs have been evaluated at wind power installed power as opposed to at desalination installed power.

³ 5-yr MACRS (Modified Accelerated Cost Recovery System). Depreciation percentage by year: 1st 20 %; 2nd 32 %; 3rd 19.2 %; 4th 11.5 %; 5th 11.5 %; 6th 5.8 %.

⁴ LCOE represents the present value of project costs expressed in value of electricity generated over its life and is calculated through a simplified model. SPRA prices represent the money value of the project over its life and are calculated through a cash flow model.

potential for a profitable investment. In order to get maximized returns, the higher a project's IRR is, the more profitable is the choice of undertaking the project. Analyses have been carried out at different expected IRRs (from 1 % through 25 %), in order to investigate trends in dependent variables (LCOE and SPRA prices). The LCOE is an indicator of the revenue required to build and operate an electrical power generation plant over a specified cost recovery period (over its lifetime). It accounts for the average revenue per kWh of generated electrical energy that is required to recover building/operating costs of a power generation plant during an established lifetime, so it may be useful to compare different power generation resources as well. The project revenue is represented by the SPRA price monetary value of the project over its life. The project's SPRA revenue is the economical value from electricity sales at the SPRA price, with an optional annual escalation rate.

$SPRA\ price_{(NDR)}$ at Nominal Discount Rate (NDR) takes into account an Inflation Rate equal to 2.5 % (Tab. 2), as opposed to $SPRA\ price_{(RDR)}$ at Real Discount Rate (RDR). As a SPRA price should be greater than a levelized nominal cost for an economical viable project, the importance of incentivizing has to be highlighted (Fig. 4 - Fig. 7).

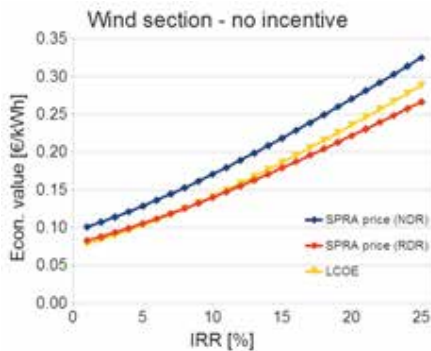

Figure 4 - Wind farm alone. No incentive case. LCOE and SPRA prices trends.

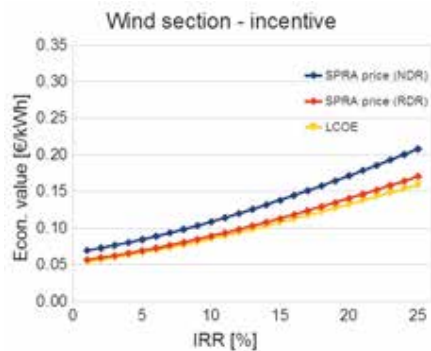

Figure 5 - Wind farm alone. Incentive case. LCOE and SPRA prices trends.

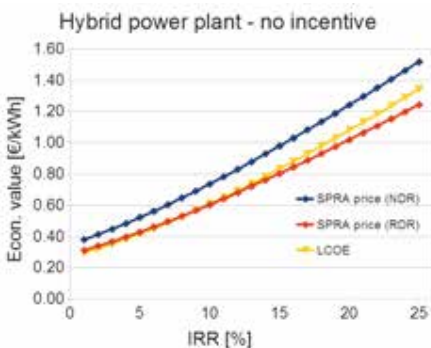

Figure 6 - Wind farm + RO desalination plant. No incentive case. LCOE and SPRA prices trends.

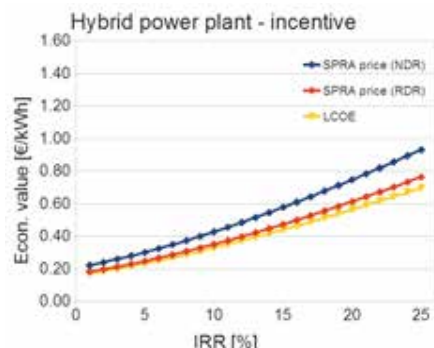

Figure 7 - Wind farm + RO desalination plant. Incentive case. LCOE and SPRA prices trends.

Fig. 4 and Fig. 5 show trends in LCOE and SPRA prices vs. IRRs for the wind farm alone (independent grid-connected power generation system): the incentivized case is compared to the unincentivized case. Economical values lower than 0.33 €/kWh drop to economical values lower than 0.21 €/kWh. Fig. 6 and Fig. 7 show trends in LCOE and SPRA prices vs. IRRs for the wind farm coupled to the RO desalination plant (hybrid system): the incentivized case is compared to the unincentivized case. Economical values lower than 1.52 €/kWh drop to economical values lower than 0.93 €/kWh.

It is to be noted – due specifically to desalination capital cost recovery reasons – the extremely higher costs for a hybrid system vs. a wind alone power generation plant (no incentive scenario: 4÷4.5 times as high; incentive scenario: 3÷4.3 times as high); on the other hand the higher costs for a no incentive scenario vs. an incentive scenario case (wind alone power generation plant: 1.5÷1.6 times as high; hybrid system: 1.3÷1.9 times as high).

This result is consistent with expectations, as it may be deduced from the framework and incentivization policy for renewable sources, whose trend is characterized by a progressive reduction in original incentivization over years, as it has been previously discussed [4]. Anyway, as the current analysis shows, in a hybrid system configuration, costs and prices may become higher way beyond competitive limits, due to reasons specifically dealing with the coupled industrial process, whose technology may prove to be the factor responsible for an increased cost. On account of such a context, a suitable supportive economical policy should be introduced for such kind of specific projects, at a regional/national level, in order grant them an eventual preferential condition and special treatment: it is to be mentioned their priority related to communal advantage, due to social reasons and an irremissible benefits (water disposal for a society), with a favourable advantaging policy for an entire population.

Conclusions

A research has been carried out in order to assess the economics about powering a hybrid RO process plant through renewables in the actual Italian deregulated Electrical Market scenario. A relatively in-depth analysis of the prospects of desalination plants powered by renewable sources has shown that RED is a growing technology supported by a constant research in the field of environmental sustainability, yet still it is disadvantageously penalized when compared to traditional technologies. Energy needs of a seawater RO desalination plant, to be located on a small island, powered by a wind farm (capable of matching its peak power requirements) and coupled to it in a hybrid system configuration, have been taken as a test case. Consequent results show that costs and prices may become higher way beyond competitive limits, but incentivization play an important role in mitigating the gap in such limits. By focusing the attention to the electrical market scenario and subsidizations reference, results have been achieved to be subsequently compared with environmental and social reasons, which can be evaluated as well.

References

- [1] A. Alkaisi, R. Mossad, A. Sharifian-Barforoush (2017) - *A review of the water desalination systems integrated with renewable energy*, *Energia Procedia*, 110, 268-274.
- [2] U. Caldera, D. Bogdanov, S. Afanasyeva, C. Breyer (2018) - *Role of Seawater Desalination in the Management of an Integrated Water and 100% Renewable Energy Based Power Sector in Saudi Arabia*, *Water*, 10, 3.
- [3] M. A. Abdelkareem, M. El Haj Assad, E. T. Sayed, B. Soudan (2018) - *Recent progress in the use of renewable energy sources to power water desalination plants*, *Desalination*, 435, 97-113.
- [4] M. Marini, A. Bono, E. Casti (2018) - *Renewable primary power source for desalination plants in coastal zones. Analysis and economical assessment in a dispatching regulatory policy*, *Proceedings of Seventh International Symposium Monitoring of Mediterranean coastal areas - Problems and measurements techniques*, Livorno, Italy, 19-21 June 2018, pp. 441-452.
- [5] M. Marini, C. Palomba, P. Rizzi, E. Casti, A. Marcia, M. Paderi (2017) - *A multicriteria analysis as decision-making tool for sustainable desalination: the Asinara island case study*, *Desalination and Water Treatment*, 61, 274-283.
- [6] E. Lantz (2013) - *Operations Expenditures: Historical Trends and Continuing Challenges*, NREL/PR-6A20-58606, AWEA Wind Power Conference, Chicago, Illinois, USA, 7 May 2013.
- [7] U.S. Department of Energy, Pacific Northwest National Laboratory (2014) - *2013 Distributed wind market report*, August 2014.
- [8] IRENA (2019) - *Renewable Power Generation Costs in 2018*, International Renewable Energy Agency, Abu Dhabi, UAE, May 2019.
- [9] Water Reuse Association (2012) - *Seawater Desalination Costs*, White paper, January 2012.
- [10] N. Ghaffour, T. M. Missimer, G. L. Amy (2013) - *Technical review and evaluation of the economics of water desalination: Current and future challenges for better water supply sustainability*, *Desalination*, 309, 197-207.
- [11] R. Huehmer, J. Gomez, J. Curl, K. Moore (2011) - *Cost modeling of desalination systems*, IDA World Congress – Perth Convention and Exhibition Centre (PCEC), Perth, Western Australia, 4-9 September 2011, IDAWC/PER11-302.
- [12] ALMAR Water solutions (2016) - *Desalination Technologies and Economics: CAPEX, OPEX & Technological Game Changers to Come*, *Proceedings of Mediterranean Regional Technical Meeting*, CMI, Marseille, France, 12-14 December 2016.
- [13] F. Esmailion (2020) - *Hybrid renewable energy systems for desalination*, *Applied Water Science*, 10, 84.

THE ECONOMIC-ENVIRONMENTAL IMPACT ANALYSIS IN THE CHOICE OF THE MANAGEMENT OF THE DREDGING MATERIALS OF A PORT BASIN IN RELATION TO THEIR CLASSIFICATION AND QUALITY: THE EXPERIENCE OF THE PORT OF TERMOLI (2018)

Antonietta Cioffi¹, Fedele Cuculo², Lucia Di Nucci³, Gianmarco Orlando⁴

¹ ARPA Molise, via dei Lecci 66, Termoli

phone 087/492695 e-mail antonella.cioffi@arpamolise.it

² Regione Molise, Viale Elena, 1, Campobasso

Phone 0874/429289, e-mail: cuculo.fedele@mail.regione.molise.it

³ ARPA Molise, C.da Selva Piana, Campobasso,

Phone 0874 492600, e-mail: luciadinucci@gmail.com

⁴ financial controller consultant rue des Coudes Cornettes 93230 Romainville France

phone 0033 0611297989, mail gianmarco_orlando@hotmail.com

Abstract - The work to be illustrated shows the comparison of the economic and environmental impact analysis in a study case: "Dredging work on the seabed of the port of Termoli 2018". The entry into force of Ministerial Decree 173/2016 (ecotoxicological characterization of the sediments of the dredging area and of the diving area led). The new assessment required the search for solutions that summarized the economic aspects, linked to the financing available, and the adoption of a new technology that would allow a system process aimed at a better environmental protection.

Introduction

The Termoli's harbor, nowadays, has the typical structure formed by a basin with two breakwaters: the one "over-billow" has the function of repairing the stretch of water (outer harbor and the interior dock) from the differences conditions of the sea caused by the principals winds (mistral, north-east wind, north wind), the "over-billow" is oriented to east and it develops, orthogonally, at the end of the bedrocks of Termoli's promontory, it contains the sea conditions from secondary winds like east wind and south-east wind (which is protected by the Gargano's promontory).

The outers breakwaters, in using today, of Termoli's Harbor are not able to weaken "in an effective way" the waves. Therefore, in particular conditions of swell and/or strong east and north-east winds, the residual water can rough in the canal between the outer harbor and the docks which might cause strong oscillation of the boats. To avoid this problem, it's required a stronger keel clearance and problems to the seabed high -6 m AMSL.

The last dredging intervention of Termoli's harbor has been made in 2002 (reaching -6 m AMSL, then 120 000 m³ of waste was spread on open sea).



Photo 1 - Aerial shot of the port of Termoli.

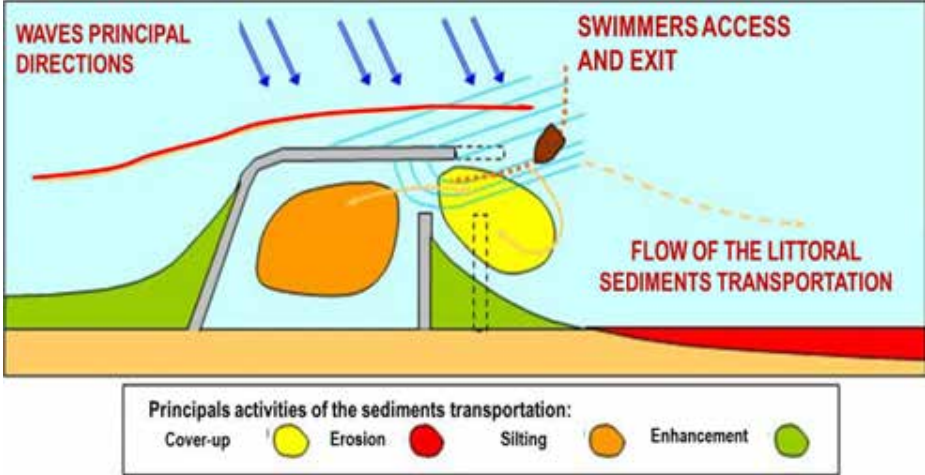

Picture 1 - Principals activities of the sediments transportation.

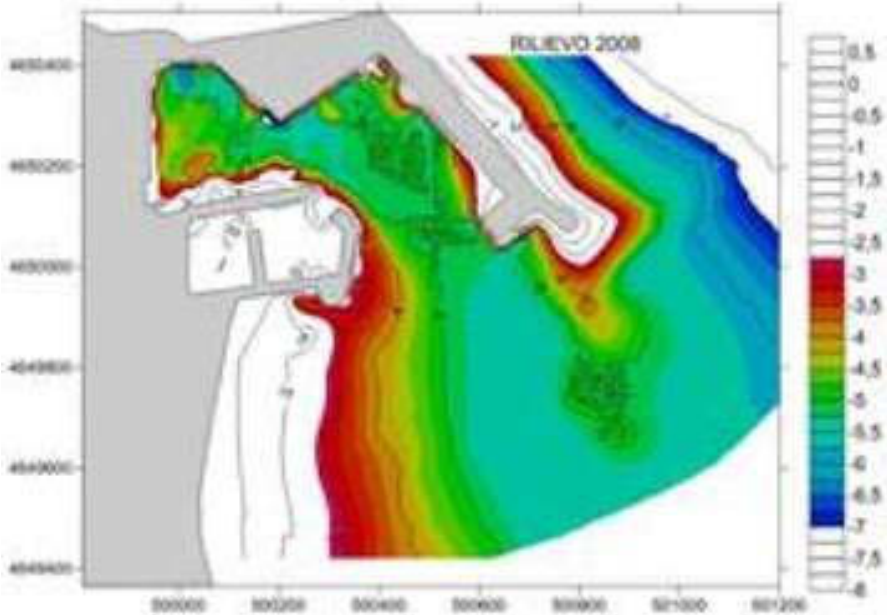

Picture 4 - Bathymetric topographic survey; Port of Termoli 2008.

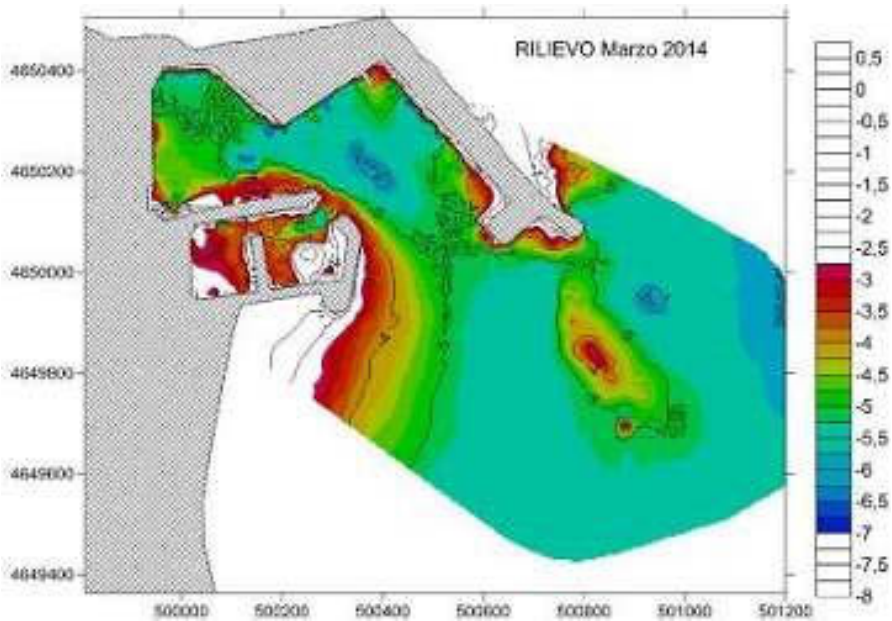

Picture 5 - Bathymetric topographic survey; Port of Termoli 03/2014.

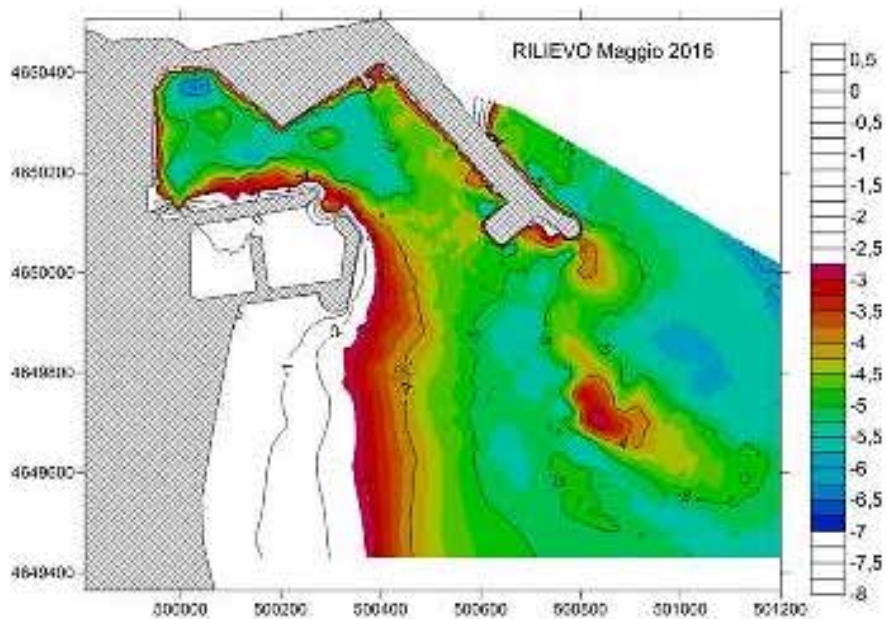

Picture 6 - Bathymetric topographic survey; Port of Termoli 05/2016.

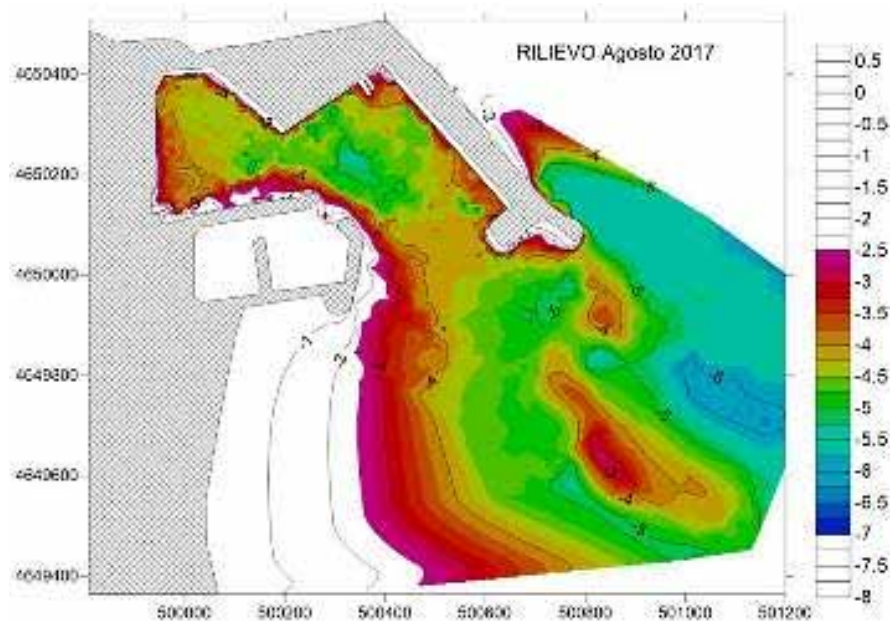

Picture 7 - Bathymetric topographic survey; Port of Termoli 08/2017.

Materials and Methods

In August 2015, on behalf of the Molise Region, the Arpa Molise closed the investigation campaign aimed at sampling and characterizing the port sediments, the access channel and the outpost, in line with the provisions:

- 1) by the Decree of the Ministry of the Environment of 24 January 1996, concerning the preliminary activities for the release of the authorizations referred to the article 11 of the law 10 May 1976, n. 319 and subsequent amendments and integrations related to the discharge into the waters of the sea or in adjacent environments of the materials coming from excavation of sea or brackish seabed or of emerged coastal soils, as well as from any high movement of sediments in marine environments;
- 2) About what reported in the tables 2.3A, 2.3B and 2.3C of book ICRAM-APAT 2007 "Manual for the handling of marine sediments";
- 3) About what provisioned by Legislative Decree 152/2006 in article 109;

34 samplings in the dredging area and 6 samplings in the spill area identified offshore have been made.

The following physical characteristics have been found: description of macroscopic appearance (color, smell, possible presence of coarse materials), the grain size according to the Wentworth scale, the specific weight and humidity.

The chemical characterization concerned the following elements: Total Organic Carbon (TOC), Total Nitrogen in N, Total Phosphorus in P, Aluminum, Arsenic, Cadmium, Total Chromium, Iron, Mercury, Nickel, Lead, Copper, Total Hydrocarbons, total PCBs and Organochlorine pesticides.

The microbiological characterization concerned the following elements: Total coliforms, Faecal coliforms, Salmonella, Mycetes, Sulphite clostridia – reducers.

Based on the results of the chemical - physical and microbiological analysis, it is concluded: *"(...) is compatible the unloading of the materials and the excavation of the seabed coming from the port and the outpost of Termoli, limited to the areas characterized by the marine area indicated by the Molise Region and corresponding to the quadrilateral identified offshore Termoli and by the vertices corresponding to .coordinates" [5].*

Table 1 - Limits of the offshore storage area.

Quadrilateral vertices	Coordinates N	Coordinates E
A	42° 06' 30''	15° 06' 30''
B	42° 06' 30''	15° 08' 00''
C	42° 07' 30''	15° 06' 30''
D	42° 07' 30''	15° 08' 00''

With the entry into force of Ministerial Decree 173/2016, according to what is reported in Chapter 2 of the Technical Annex for the quality assessment of the sediments to be dredged and immersed in a special spill site, before the start of the works it was necessary to follow a specific investigation path (Path I), since it is an internal area of a port even partially industrial, commercial, passenger service, fishing boats.

Results

For the Eco toxicological and chemical classification of sediments, the weighted integration criteria were applied, set out in Appendices 2B and 2C of the Decree of the Ministry of the Environment and Protection of the Territory and the Sea of 21 September 2016 n.173. After it was proceeded with their integration, in order to determine the quality class of the sediments, always using of the applicative tool named Sediqualesoft.

The Eco toxicological classification was based on an Eco toxicological hazard judgment (Absent ÷ Very High) elaborated by the weighted integration of the results of all the components of the whole battery of biological tests (3 for each sediment sample).

The chemical classification, instead, was based on the elaboration of a chemical Hazard Quotient index (HQc), that considers the type and the number of parameters not compliant, as well as the extent of these exceedances and on its subsequent attribution in a hazard class (absent ÷ very high).

Based on the integration of data, coming from the chemical and Eco toxicological classification of each sample, it was possible to determine the quality class of the material, as indicated in the table 2.7 of annex A.

Table 2 - Quality class of the material (cfr. Annex A Table 2.7).

Ecotoxicological hazard class developed for the whole battery (HQ batteria)	Chemical classification	Quality class of the material
Absent	$HQc(L2) \leq \text{Negligible}$	A
	$\text{Low} < HQc(L2) < \text{Medium}$	B
	$HQc(L2) = \text{High}$	C
	$HQc(L2) > \text{High}$	D
Low	$HQc(L1) \leq \text{Low}$	A
	$HQc(L1) < \text{Medium}$ and $HQc(L2) \leq \text{Low}$	B
	$\text{Medium} \leq HQc(L2) \leq \text{High}$	C
	$HQc(L2) > \text{High}$	D
Medium	$HQc(L2) \leq \text{Low}$	C
	$HQc(L2) \geq \text{Medium}$	D
$\geq \text{High}$	$HQc(L2) \leq \text{Low}$	D
	$HQc(L2) \geq \text{Medium}$	E

The area subject of the dredging works was divided into 6 sub-areas unit so distinct (Picture 3):

- n° 1 unitary sub-area D3 on the external mouth of 50 m x 50 m side adjacent to the quay (type 1);
- n° 2 unitary sub-areas D1 and D2 in the access step to the port, side 100 m x 100 m (type 2);
- n° 3 unitary sub-areas D4, D5 and D6 external to the mouth of the port with side 200 m x 200 m (type 3).

Table 3 - Quality class of the material port Termoli.

Sample code	Sample Code sub-area Sample depth from the fund	Eco toxicological hazard class	Chemical classification	% Pelite	Quality class of the material
17-AM19344	D1 F/50	HIGH	HQc (L2) ≤ Low	56.8	D
17-AM19345	D1 50/100	HIGH	HQc (L2) ≤ Low	59.3	D
17-AM19346	D1>100	HIGH	HQc (L2) ≤ Low	58.4	D
17-AM19347	D2 F/50	HIGH	HQc (L2) ≤ Low	60.1	D
17-AM19348	D2 50/100	HIGH	HQc (L2) ≤ Low	61.4	D
17-AM19349	D2>100	HIGH	HQc (L2) ≤ Low	61	D
17-AM19350	D3 F/50	HIGH	HQc (L2) ≤ Low	62.8	D
17-AM19351	D3 50/100	HIGH	HQc (L2) ≤ Low	63.1	D
17-AM19352	D3>100	HIGH	HQc (L2) ≤ Low	42.1	C
17-AM19353	D4 F/50	ABSENT	HQc (L2) ≤ Negl	7.2	A
17-AM19354	D4 50/100	MEDIUM	HQc (L2) ≤ Low	5.2	C
17-AM19355	D5/50	ABSENT	HQc (L2) < Negl	25.1	A
17-AM19356	D5 50/100	ABSENT	HQc (L2) < Negl	6.9	A
17-AM19357	D6 F/50	ABSENT	HQc (L2) < Negl	5.4	A
17-AM19358	D6 50/100	MEDIUM	HQc (L2) < Low	2.7	C

Discussion

According to the monitoring studies led by Arpa Molise and the into force regulations of November 2015, the totality of materials coming from the Termoli's harbor dredging could be immersed in a compatible area chosen in open sea.

With the drafting of the final project (August 2017), according to the new normative, the results of the environmental analyses, led from October 2017 and January 2018, have showed the impossibility to dissipate, in open sea, wastes "as such" as they were in the harbor's canal, but it is important to divide the dredging activity in two different areas:

- Zone A of the external canal of the harbor's entrance, where the waste materials coming from the dredging can be:
 1. dissipate in open sea, with the limit of 160 000 m³ of volume; 50 cm of superficial thickness from the maximum depth (i.e. between -5.4 m e 5.6 m ASLM). At this level deposits have to be of Class A, they have to plainly respect the environmental conditions in order to be deliberately dissolved in sea areas far from the cost (more than three miles).
 2. made of deposits of inferior thickness (so up to a depth of dredging of -6.0 m ASLM) which are included to the class C of the environmental quality, but they have to respect the standards values (physical, chemical end eco-toxicological) with a better environmental quality than deposits located on the seabed of the chosen area

(as indicated by Molise region in Det. Dir. n.5976/2015, the initial project which still in progress), but they aren't an arm for the environmental quality of the sea.

- Zone B of the internal canal of the harbor's entrance, materials coming from the dredging have to have a maximum volume of 51 000 m³, but it must be treated in order to select and divide:
 1. the sandy fraction (about 43 000 m³ dissipate far from the coast)
 2. the thinner fraction (maximum 8 000 m³) which should be spread on the internal seabed of the harbor, in areas which were previously selected and agreed by the city hall and the coast guard. Therefore the analyses conducted on samples selected in the zone B show that deposits are class D and so, according to the norms, the materials come from the dredging have to be treated to select the smallest fractions in order to reduce the amount of toxic substances of the sandy fraction before it can be dissipated in open sea in the same amount as the zone A.

Conclusion

The coming into force of the new "Regulation concerning the modality and criteria for the authorization to dissipate, in the sea, materials coming from the digging of the seabed" (DM 15 July 2016 n.173) states the priority of the management strategies to be adopted.

In the management strategy of the Termoli's harbor it's been fundamental to find solutions, in order to respect the budget of a prior contract.

Therefore, in order to limit operational costs and to complete the operations of dissipation in open sea of the dredging deposits (less management costs), which was included and counted in the preliminary draft, confirmed in final draft and presented to the contractor during the tender, it was necessary to execute the operations of dredging of the zone b, provide two extra interventions:

- The first consist in the "cleaning" of the granulometric fraction, the thinnest, of the material which was dredged at the interior of the harbor, with a maximum quantity of 51 000 m³, following the technique called "Sedimentological washing".
- The second, the sedimentological washing; is a process of granulometric separation of deposits, firstly remove the thinnest granulometric component (pelite) by using pumps and water jets which are presents in the hopper of the dredger.

By activating the pumps, the materials, present in the hopper waterproofed, has been diluted and transformed in a mix of water and sand at the interior of the hopper. Little by little that the water injected by the pumps fill, the hopper the thinner components are pulled through the top and the water jets, which are located on the side of the hopper, help the components to be ejected by the "overflow system". This technique consists of the two gates, located on the top of the hopper, which help to regulate the amount of water by sliding the excess of water and keeping inside the thicker granulometric component. During the overflow, in order to limit the dispersion of thin deposits in the harbor's basin; purlins PVC are been used to favorite the deposit of these "keels" in the area where the dredger is stopped. Once the operations of the Sedimentological washing are finished, the thinnest components remain in the harbor limited area thank to the purlins; on the other hand, bigger components are ready to be ejected in the sea. From this moment it's possible to start a

second dredge and spread the deposits all along the seabed of the port in area selected and agreed with the cost guards. Different analysis were led to find out the costs of all operations, taking in consideration the machinery needed and, in function of the length and the productivity of a work cycle, obtain the unitary cost which were used to the final draft of the budget.

To follow it will be reported the analyses of the costs of the two extra operations.

NP1: A higher price is applied for the dredging because the extra treatments of the materials dredged at the interior of the Termoli's harbor which are class D of the environmental quality scale. The analysis of the production cycle led to estimate a unitary cost for a meter cube of deposit equal to 3.36 €.

NP2: A higher price is applied for the dredging because the transportation of the materials (class D of the environmental quality scale) dredged in Termoli's harbor. The analysis of the production cycle led to estimate a unitary cost for a meter cube of deposit equal to 1.98 €.

At the end of new enquiries of the environmental characteristics of deposits (according to the DM 173/2016), it has been necessary to add to the executive project two extra operations in order to treat the sediments dredged in the port. For those operations, an analysis has been led in order to define the costs which have increased of 7 % the total cost.

Aknowledgement

For the drafting of this project we thank the Molise region, The Arpa Molise, La Dragaggi srl Marghera 30100 Venice and the Envitech srl Servizi e tecnologia per l'ambiente – 54100 Massa, for the classification and characterization of the Termoli's harbor deposits.

Bibliography

- [1] VV.AA. (2007) - *Il Manuale per la Movimentazione dei Sedimenti Marini*; ICRAM-APAT [https://www.isprambiente.gov.it/contentfiles/00006700/6770-manuale-apat-icram-2007.pdf/](https://www.isprambiente.gov.it/contentfiles/00006700/6770-manuale-apat-icram-2007.pdf)
- [2] Decree of the Ministry of the Environment and Protection of the Territory and the Sea of 21 September 2016 n.173 “*Regolamento recante modalità e criteri tecnici per l'autorizzazione all'immersione in mare dei materiali di escavo di fondali marini*” and related technical attachments;
- [3] VV.AA. (2015) - *Environmental feasibility study (November 2015) for the preliminary project of the dredging works of the port of Termoli*
- [4] La Dragaggi srl (2018) - *Executive design of the dredging works of the port bottoms of the port of Termoli*
- [5] Envitech srl company Environmental services and technologies (2018) - *Characterization and classification of the sediments of the port of Termoli*, January 2018

FEASIBILITY STUDY OF A COLD IRONING SYSTEM AND DISTRICT HEATING IN PORT AREA

Daniele Colarossi¹, Paolo Principi¹

¹Department of Industrial Engineering and Mathematical Sciences, Università Politecnica delle Marche, Via Breccie Bianche, Ancona, Italy

Phone +39 071 2204773, e-mail: d.colarossi@pm.univpm.it

Abstract – Among the possibilities for the reduction of pollution in port areas, cold ironing satisfies the electrical power demand of ships while they are at berth replacing on board diesel generators. Through cold ironing ships can shut down their auxiliary engines. In this paper, a feasibility study for the port of Ancona is proposed, considering only the ferry docks. A methodology of analysis of the electrical loads required by the ships while they're at berth is presented. The power is provided by a cogeneration plant powered by natural gas which allows to produce electrical energy at a lower price than what would be obtained from the grid. The energy demand is linked to the presence of ships in port which means it varies greatly over time, hence a Compressed Air Energy Storage system is installed. The heat waste recovered from the cogenerator is used in a ring district heating network. Finally, the economical aspect has been evaluated to prove the feasibility of the whole system. The results show that a 1.5 MW and 2 MW cogenerator covers 83.05 % and 92.5 % of the electrical need of ships respectively, and 61 % and 74 % of the thermal need of buildings over the analysed period. Both scenarios prove to be economically feasible.

Introduction

Over the years the continuous increase in maritime traffic of goods and people, both by ferries and cruises (which have the highest growth rate), highlights the problem of environmental pollution in port areas, especially when the port is in the proximity of urban areas. According to IMO (International Maritime Organization), maritime traffic contributes to CO₂ global emissions for approximately 2.2 % (2014) [1]. It is estimated that the naval transport sector generates about a billion tons of CO₂, expected to become, according to forecasts, 1.6 billion tons in 2050 [2]. In addition, ships contribute to NO_x, SO_x and PM emissions in varying degrees depending on the type of engines and fuel used by the ships.

This paper presents the cold ironing system [3] for the port of Ancona, as a solution for the reduction of environmental pollution in port area. Thanks to on-shore power, the energy demand of berthed ships is satisfied and they can shut down their on-board diesel generators. The energy is provided by a cogenerator, where the thermal energy produced is recovered to air-condition a series of buildings (reducing the usage of the traditional boilers) and to ensure an additional benefit on the environmental impact.

Materials and methods

The objective of the study is to illustrate the benefits of on-site energy production in terms of pollution reduction. It is worth noting that if the energy from the grid does not come from an efficient and renewable source, the result is simply a displacement of the polluting source from the ships to the centralized production site. Cogeneration provides highly efficient energy and it ensures energy saving. Although the power plant is in the port area, it is small and the pollutant emissions are easily controllable. Another advantage is that transmission losses are avoided along the network. The high cost of electrical energy from grid in Italy is also part of why on-site energy production is favourable over a grid-connected configuration.

The system consists of a cogeneration plant, where electricity and heat are produced. The electrical energy is used to power the ships at berth, while the thermal energy is exploited to air-condition a series of buildings through a heating district network. This allows the overall efficiency of the plant to be significantly increased and consequently lowers the cost of energy production. Selling energy distributed to those buildings comprises another source of economic gain for the return on the investment costs for the project. The cogenerator is flanked by the CAES (Compressed Air Energy Storage) since the electrical demand is highly variable, because it is linked to the presence of ships anchored in port. The plant scheme is depicted as in figure 1.

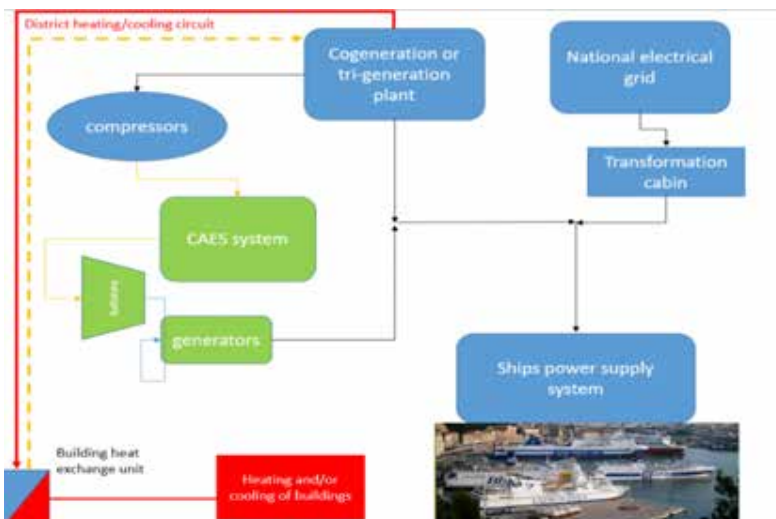

Figure 1 - Block diagram of the proposed system.

The energy analysis, upon the indication of the Central Adriatic Ports Authority, only concerns the ferry docks. Ferry ships have a fairly regular call frequency, and they do not require high power, as is the case of cruise ships. The ferry docks are number 8-9-11-13-15-16, as depicted in figure 2.

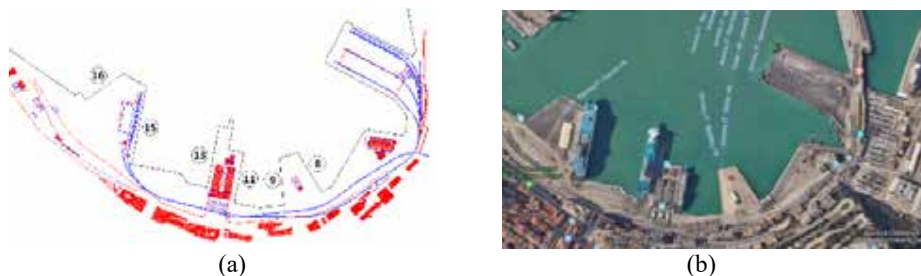

Figure 2 - Area under study of the port of Ancona: CAD (a) and satellite view (b).

Table 1 - List of ferry ships in the port of Ancona and associated power.

	N° generators	Power each [kW]	Average power [kW]	
			Summer	Winter
Ship 1	3	2100	1600	1600
Ship 2	3	1400	1550	1000
Ship 3	3	1400	1550	1000
Ship 4	3	1900	2200	2200
Ship 5	3	3800	2200	2200
Ship 6	4	850	1200	1200
Ship 7	3	1360	800	800
Ship 8	2	960	500	350
Ship 9	4	783	600	600
Ship 10	3	945	800	800

To evaluate the power and the other electrical characteristics requested by each ship at berth, a series of meetings and on-ship inspections were held with the shipping companies and the Port Authority. In table 1 the collected data have been summarized (the names of the ships or shipping companies present in port have not been reported, but the ships have been numbered).

The analysis was carried out over a one-year period, from 01-08-2018 to 31-07-2019. The simultaneous presence of ships in port was necessary to determine the trend of the required electric power. The data were collected from the PMIS portal (Port Management Information System), that contains all the times of stay of each ship on the quay, tabulated according to the day and time of arrival and departure and the number of the quay. The sum of the powers required by the ships present at any given time determines the electrical needs to be met. The analysis was made considering the typical week for each month on an hourly basis. Here only the extreme cases are reported, namely January and July (figure 3).

Since the ships that are part of the analysis are scheduled ferries that connect the port of Ancona with those of Croatia and Greece, the winter months are characterized by a low frequency of calls which determines a low average load of energy required, while the summer months are characterized by a higher frequency of calls with traffic-due shorter stays mainly concentrated during the day.

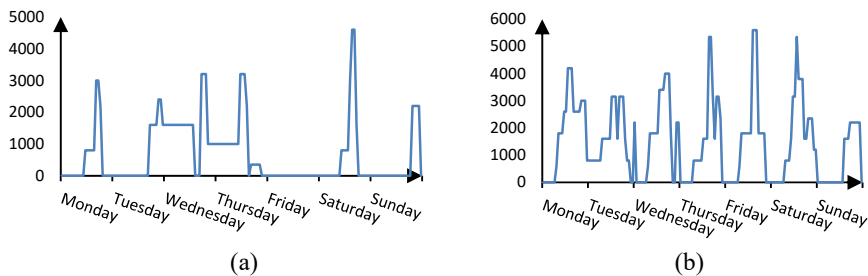

Figure 3 - Trend of electrical energy demand (kWh) of ships at berth during January (a), July (b).

Table 2 - Thermal energy demand [kW] of buildings in winter and summer.

Buildings		Winter	Summer
1	Non-commissioned officers club	338	-
2	Finance police HQ Tommaso Mariani	238	-
3	Former Fincantieri administrative offices	132	145
4	Port Authorities	469	480
5	Current maritime station	632	599
6	Port Authorities 2	168	-
7	Border police	247	350
8	Coast Guard	214	-
9	Administrative court	427	436
10	ITN Elia	612	-
11	INAIL	351	417
12	Fincantieri canteen	565	-
13	Finance police HQ Carlo Grassi	150	176
14	New Port Authority headquarters	877	945
		5474	3604

As regards the thermal analysis of buildings, the thermal loads in summer and the heat losses in winter through the building envelope were evaluated. For the calculation of the overall heat transfer coefficient of the walls, roofs, floors and glazed surfaces, typical stratifications, based on the year of construction, for each building have been assumed. The results of thermal analyses carried out on the buildings to be air conditioned are summarized in table 2.

These values are useful for sizing the equipment, such as central heating boilers, chillers and auxiliary devices. To carry out an analysis of real consumptions, it was necessary to define the “average monthly day” according to the climate data on an hourly basis, taken from the CNR (Italian National Research Council) databases [4] for winter months and also the relative humidity and solar radiation for the summer months. Furthermore, for a better completeness it was decided to differentiate between the working days and the holidays. In the latter, the buildings used as offices, remain closed and are therefore not involved in air conditioning.

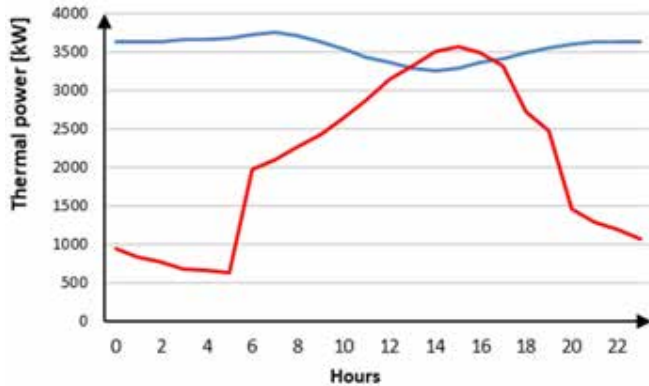

Figure 4 - Trend of thermal demand of buildings for a typical weekday in January (blue) and July (red).

Figure 4 depicts the trend of a winter month (January in blue) and of a summer month (July in red). For the winter months it is enough to consider the outside temperature. The minimum of the trend occurs during the hottest hours of the day. In a summer month, the temperature values for calculating the heat transmitted through the building envelope and the incident solar radiation on the surfaces (both opaque and transparent) are reported in the Italian standard. The trend shows a peak of thermal power in the hours with the maximum solar radiation.

A ring district heating network [5] connects the thermal power plant to the buildings located near the port area. In figure 5 each of them is identified with a number on the map. The list also includes the new headquarters of the Port Authority to be built.



Figure 5 - Heating district network and position of buildings on the map.

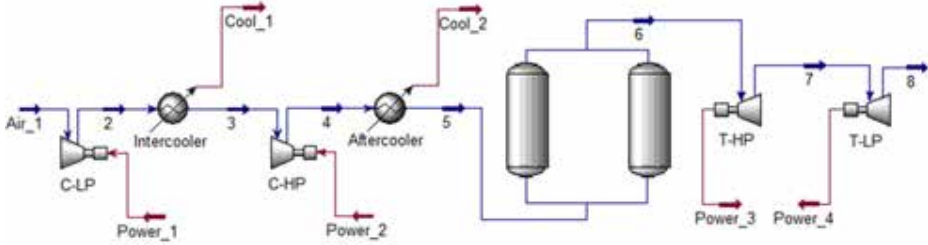

Figure 6 - Plant layout of a CAES system.

The CAES system [6-8] stores energy when the required amount is less than the produced one. Then it is expended when the potential of the cogenerator is insufficient to satisfy the energy demand, namely when more ships are present in port. The CAES system is composed of three parts, charging via compressors (single or multiple), storage in tanks and discharging into turbines, as depicted in figure 6.

The sizing of a CAES system is based on the choice of a set parameter, in the present case study the tank charging time. It has been evaluated considering the average of the times in which there is no demand for energy due to the absence of ships in port. This time can be used to charge the tanks.

Results and discussion

In the present work, the annual average of the electrical load that was calculated, as shown in figure 7, nears 1394 kW.

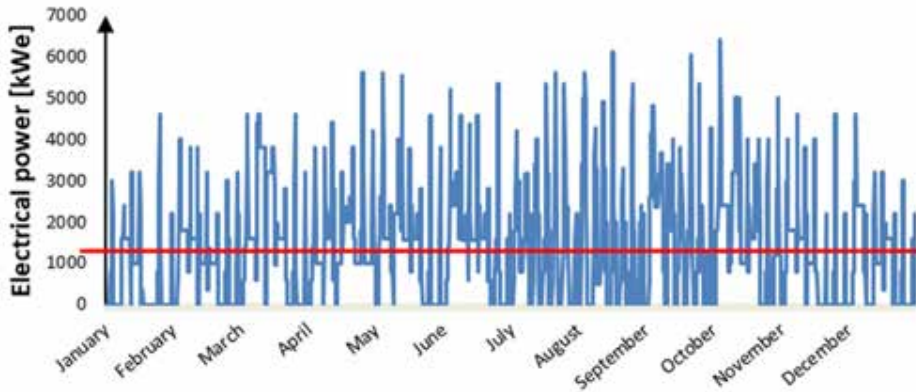

Figure 7 - Annual trend of electrical energy required by ships at berth. The red line indicates the average over the year analysed.

The idea is to create a constant production of energy and to balance the moments of non-demand of energy with the moments of maximum demand, leaving the task of "load tracking" to the storage system. Two different scenarios are hypothesized. The first simulation led to the evaluation of a 1560 kW cogenerator to stay as close as possible to the average annual load. For the second simulation instead, a 2 MW power plant was chosen, with the aim of increasing the autonomy of the system and supply a greater amount of thermal energy to the buildings (table 3). The results are shown in the two pie charts of figure 8.

Table 3 - Simulations carried out.

	Power [kW]	Thermal efficiency [%]	Electrical efficiency [%]	Overall efficiency [%]
Scenario A	1560	43.8	43.2	87
Scenario B	2000	43.2	43.7	86.9

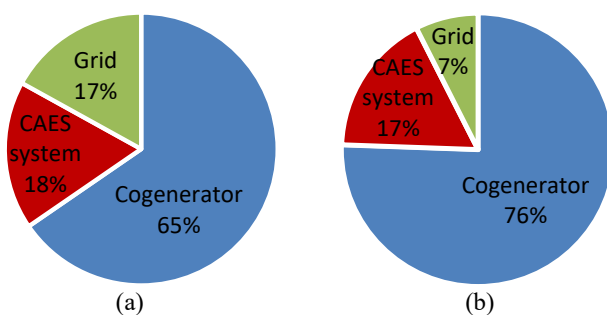

Figure 8 - Coverage of electricity needs for the 1560 kW scenario (a) and the 2000 kW scenario (b).

As shown in figure 8, the first scenario (1560 kW) provides less autonomy than the second one (2000 kW). With a larger power plant it is necessary to withdraw from the network only 7% of the energy required by the ships, and it rises to 17% with a smaller sized cogenerator. In both cases there are quotas of energy transferred and purchased from the grid, due to the dynamic nature of the request. It can be noted that the percentage satisfied by the CAES system is not influenced by the size of the cogenerator. Overall scenario (b) allows greater energy autonomy, in fact it is self-sufficient for electricity supply for three months a year, while scenario (a) is self-sufficient only for one month.

The results from a thermal point of view are analysed by looking at the percentage covered by the thermal energy requirement of the buildings. The trend is variable and reaches a minimum value in January, where the energy request is higher than the other months. Overall, the 2 MW plant covers almost 15% more, as it recovers a greater amount of thermal energy. The results in detail over the whole year are shown in figure 9.

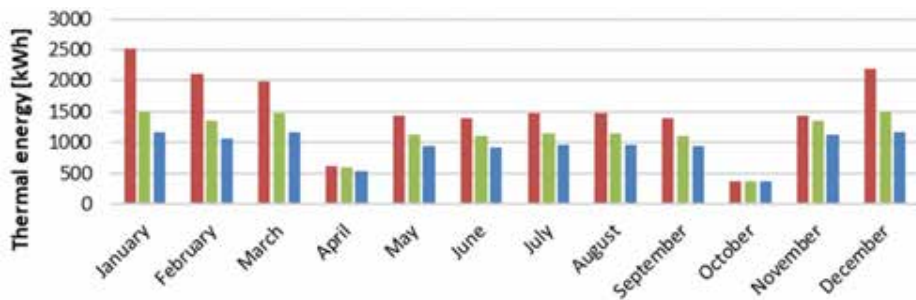

Figure 9 - Coverage of thermal demand. Red indicates the thermal energy demand, green the energy provided by scenario (b), while blue indicates scenario (a).

The index used to evaluate the energy saving is the PES (Primary Energy Saving). It is calculated as follows:

$$PES = 1 - \frac{1}{\frac{\eta_{th,CHP}}{\eta_{th,s}} + \frac{\eta_{el,CHP}}{\eta_{el,s}}} \quad 1$$

Where $\eta_{th,CHP}$ is the thermal efficiency of the cogenerator, defined as ratio between the useful heat and the fuel supply used to produce the sum of useful heat output and electricity from cogeneration, $\eta_{th,s}$ is the reference thermal efficiency of separate production, $\eta_{el,CHP}$ defined as "annual electricity from cogeneration" divided by the fuel input used to produce the sum of useful heat output and electricity from cogeneration and $\eta_{el,s}$ is the reference electrical efficiency of separate production. From the calculation it emerges that the scenario (a) returns a PES value of 17.89 while 17.5 for that (b). The first solution is better by a slight margin, since it is the configuration that determines a greater PES minimizing the waste of energy.

For the economic analysis the NPV (Net Present Value), the IRR (Internal Rate of Return) and the PB (Pay-back) were chosen as evaluation indices. The results of the considered indices are summarized in Table 4. The best investment is therefore the one associated with scenario (b) because it produces a lower PB with a higher associated NPV and IRR. It yields a higher revenue from the sale of thermal energy and the greater revenue from the incentives linked to the increased sale of electricity to the grid.

Finally, savings are analysed from the shipowners' point of view transitioning from diesel generators to on-shore supply. The costs of generating electricity from diesel engines were compared with consumption [9] and the cost of energy from the cold ironing system. The total savings over the year are around 850 thousand euros, or about 59 % of current costs. Figure 10 shows the trend of the two costs during the period analysed.

Table 4 - Economic results.

	PB	NPV	IRR
Scenario (a)	5 years, 7 months	5 640 003.24 €	13.4 %
Scenario (b)	4 years, 5 months	10 348 968.00 €	18.9 %

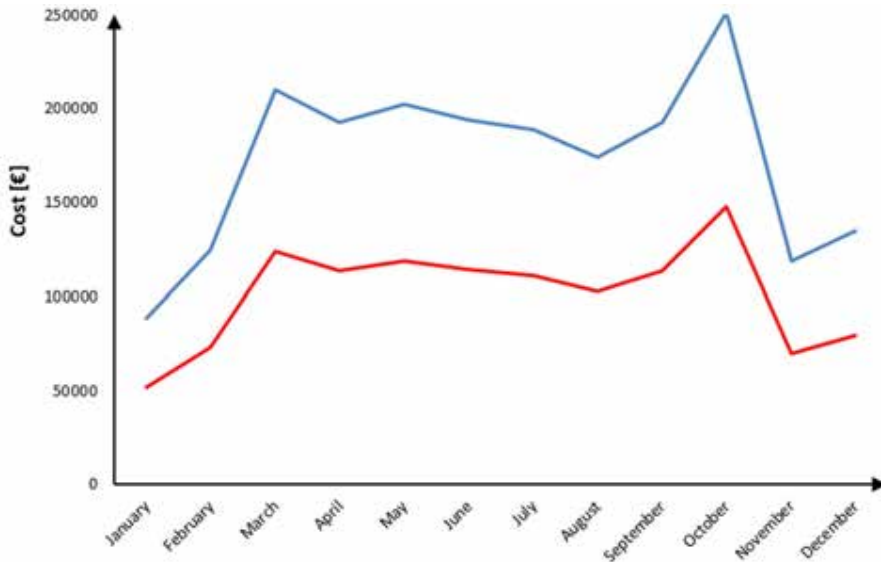

Figure 10 - Savings trend obtained from the production of electricity from cold ironing and diesel generators on board.

Conclusions

This work has proved the feasibility of a cold ironing plant in the port of Ancona and the results can be summarized as follow:

- About the energy aspect, scenario (a) (1560 kW) realises a greater PES compared to scenario (a) (2000 kW), because minimises the amount of fuel used (natural gas);
- Scenario (b) is self-sufficient for electricity supply for three months a year, while scenario (a) only for a month;
- Scenario (b) better satisfies the thermal needs of buildings (74.55 %) compared to the first scenario (61.18 %);
- Regarding the economic aspects, scenario (b) yields a greater NPV and IRR, with a lower PB.

Furthermore, the feasibility from the shipping companies' point of view has been proved.

References

- [1] Agenzia europea dell'ambiente (2016) - *I trasporti aerei e marittimi*.
- [2] IMO (2014) - *Third IMO GHG Study 2014*. International Maritime Organization (IMO), London. [Online] Available at: <http://www.iadc.org/wp-content/uploads/2014/02/MEPC-67-6-INF3-2014-Final-Report-complete.pdf>

- [3] Thalís P.V. Zís (2019) - *Prospects of cold ironing as an emissions reduction option*, Transportation Research Part A 119, 82-95.
- [4] CNR (1982) - *Dati climatici per la progettazione edile ed impiantistica*, Roma.
- [5] Versace M. (2016) - *Analisi dinamica e valutazione delle prestazioni di una rete di teleriscaldamento*, Università di Pisa.
- [6] Cárdenas B., Hoskin A., Rouse J., Garvey S. D. (2019) - *Wire-wound pressure vessels for small scale CAES*, Journal of Energy Storage 26, 100909.
- [7] Rogers A., Henderson A., Wang X., Negnevitsky M., Senior Member (2006) - *Compressed Air Energy Storage: Thermodynamic and Economic Review*, Proceedings of the IEEE Power and Energy Society General Meeting, USA, National Harbor, 27-31 July 2014, pp. 1-5.
- [8] Hartmann N., Vöhringer O., Kruck C., Eltrop L. (2012) - *Simulation and analysis of different adiabatic Compressed Air Energy Storage plant configurations*. Applied Energy 90, 541-548.
- [9] Sciutto D., Pinceti P. (2019) - *L'elettificazione delle banchine dei porti del Mar Ligure Occidentale*.

MONITORING COASTAL AREAS: A BRIEF HISTORY OF MEASURING INSTRUMENTS FOR SOLAR RADIATION

Matteo De Vincenzi, Gianni Fasano

CNR Institute of BioEconomy via Madonna del Piano 10 Sesto Fiorentino (Florence, Italy)

matteo.devincenzi@ibe.cnr.it; gianni.fasano@ibe.cnr.it

Abstract – The beginning of the development of instruments for the measurement of solar radiation is quite recent even though this quantity is the main engine of environmental physics and marine and terrestrial biology and their primary connection element as it was highlighted by environmental physics studies since second half of the 19th century. Although already in the classical era there were some mentions to the concept of solar radiation, in terms of heat and light, discussions on the role of the Sun remained on a philosophical level until the scientific revolution when the first studies were made, in the astronomical field, about solar radiation. Only in the first half of the 19th century the first specific instruments were made for measuring solar radiation for meteorological purposes such as the Pouillet pyrheliometer.

The birth of the *Organization Météorologique Internationale*, OMI, (1879) started the process that will lead to the standardization of instruments and observation methodologies for solarimetry. In 1896 OMI established the *Solar Radiation Commission*. In 1905, Third Conference of Directors of National Meteorological Services decided to take the Ångström pyrheliometer as a standard instrument. In the following decades, other types of radiometers were developed to measure the other components of solar radiation (such as the Robitzsch pyranograph in 1932) from which began the realization of instruments whose signal could be recorded analogically on the acquisition data system. Other pyranometers were realized to measure the intensity of the radiation using the Moll-Gorczynki thermopile; other versions were built using a photocell as a sensitive element.

In the last decades of the 20th century, digital recording instruments for radiometry were also realized. Furthermore, instruments have been developed that drastically reduce maintenance operations, an essential aspect for quantities measures, such as sunshine duration and diffuse radiation, performed in remote and difficult to reach sites. In the 2000s, for studies concerning physical and biological marine-oceanic quantities, apparatuses were developed for measuring solar radiation in the water column in the global blue, green and red ranges.

Introduction

Environmental physics studies of the last 150 years have shown that solar energy drives all the phenomena that occur in the atmosphere, in the oceans and on earth. In the marine and coastal environment, radiation provides the surface layers of the oceans and seas with the energy necessary for water to pass from the liquid to the vapor state, triggering the hydrological cycle. Solar radiation influences, among other phenomena, hydrodynamisms such as wave motion and sea currents and the qualitative and quantitative development of marine ecosystems. In reference to marine biology, while solar radiation is relatively little affected by the thickness of the atmosphere, it is strongly and selectively influenced by the thickness of the water. In

other words, the different frequencies that make up the visible radiation are attenuated differently from the water thickness.

In recent decades, the measure of solar radiation, especially in the UV range, has assumed importance in coastal marine areas also for the purpose of health safety of inhabitants of these areas. Various studies have showed that the greater exposure to radiation causes the onset of dermatological diseases to increase both for outdoor workers (fishermen, construction workers, lifeguards, sailors, etc.) and for beach tourists.

The Origins

The first references to a concept of solar radiation, even if in terms of heat and light, are due to Aristotle who in *Περὶ οὐρανοῦ* (On the Heavens) states that the heat and light of the stars, including the Sun, are the result of their movement that creating friction causes the ignition of the underlying air. According to Aristotle, the heat generated by the Sun gives rise on the earth's surface to a dry and a wet and cold hot exhalation that arise from the Earth and contribute to various meteorological phenomena. In classical era also Pliny the Elder wrote about the important the role of the Sun on terrestrial activities in his work *Naturalis Historia*, where he asserted that the effects of the Sun are very strong on Earth (*de cuius sideris effectas amplissimi in terra sentiuntur*).

Discussions on the role of the Sun remained purely philosophical until the scientific revolution (16th-17th century) when the first studies on solar radiation were carried out. However, for almost three centuries these studies were an astronomers' exclusive research field. Although solar radiation is the main engine of environmental physics of terrestrial and marine biology, their primary connecting element, the beginning of the study for its measurement and construction of instruments is quite recent.

It was probably H. B. de Saussure (1767 and following years) the first to contrive an instrument for measuring solar radiation. The instrument, *heliometer*, consisted of a mercury thermometer with blackened bulb protected by a transparent thin glass bubble to prevent air currents, or other disturbances, from influencing the measurement [11]. The thermometer, in the first version with a Réaumur scale, was placed in a wooden box covered with blackened cork and covered with three spaced glass plates [1] [5]. Around 1774 it seems that de Saussure used *heliometer* to directly compare the measurement of “solar heat” intensity at the top and bottom of a mountain [18]. Thanks to this instrument, de Saussure was the first to demonstrate the increase in solar radiation with altitude [5].

The development of the instruments

Only at the beginning of the 19th century, instruments for measuring solar radiation, for meteorological purposes, were made such as J. Herschel's actinometer (radiation gauge, from the Greek *aktis* radius) (1825) [4] and the *caloric collector* (later referred to as a *lucimeter*¹, or *totalizer actinometer* or *distillation actinometer*) by A. Bellani (1836) [9], [27].

¹ It was also called *lucimeter* since it was sensitive only to the visible range of solar radiation [28].

The original version², of Bellani instrument (figure 1) consisted of a graduated glass tube (T) with the lower end closed; the upper part, curved in the last section, ended in a glass sphere (A) containing easily evaporable liquid (ether or alcohol) inside which the vacuum was made. To measure the average intensity of solar radiation in a certain period, the sphere was wrapped with a black cloth. When the temperature of sphere was higher than that of the tube, the liquid evaporated and condensed collecting at the bottom of it. The level reached by the liquid in the tube allowed to find the quantity of light energy (in the visible field) received in a certain interval of time. [6], [27].

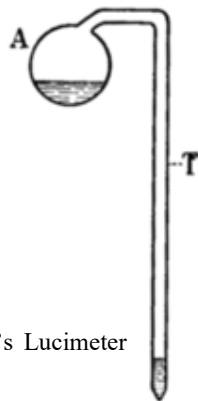

Figure 1 - Bellani's Lucimeter (1836). From [27].

These instruments were followed in 1837 by a specific for measuring the intensity of solar radiation, the Pouillet pyrhelimeter, based on a water calorimeter (figure 2) [19]. Pouillet managed to estimate the solar constant with the measurements made with this instrument, which detected only the direct component of the radiation. [8].

Figure 2 - Pouillet's pyrhelimeter (1837). A: container (calorimeter), with blackened receiver, made with a silver foil and filled with water. T: thermometer whose bulb enters the container to measure the water temperature. C-D alignment check system to orient the instrument towards the Sun. Disk in C to check the orthogonality of the sunrays with respect to the blackened surface of the calorimeter. From [9]



From the mid-nineteenth century, the first instruments for measuring sunshine duration were made that is *the time in which, during the day, the Sun manifests itself in a cloudless sky*³. In 1853 J. F. Campbell proposed a sunshine recorder which consisted of a

² In the modified (more common) version, the graduated tube (straight) had the lower end closed, while the upper open and sharpened one penetrated into a spherical glass ampoule (containing liquid evaporable in an air-free environment) colored blue. The ampoule was inside another transparent ampoule in which the vacuum had been practiced. [28]. Each lucimeter had its own sensitivity which decreased when the blue sphere was emptied, according to a law that varied from one specimen to another. To overcome this drawback, a correction table was used to bring the measurements back to those that would were carried out with an ideal instrument in standard conditions [9].

³ The WMO current definition states: sunshine duration during a given period is defined as the sum of the time for which the direct solar irradiance exceeds 120 W m^{-2} [32].

glass sphere placed in a wooden container from which it partially protruded (Figure 3a). The sphere acted as a converging lens of the sunrays which focused on the container cavity and burned the walls at different heights, day by day, and at different times of the year. The length of the burn trace indicated, roughly, the duration of presence of the Sun. The tracks produced daily tended to partially overlap, therefore their reading was not easy. The direct burning of the wood of the container made it usable only for six months and therefore it was necessary to replace it twice a year.

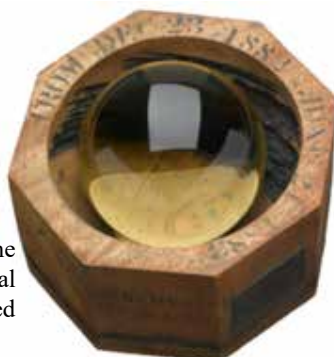

Figure 3.A - Campbell's sunshine recorder: the spherical lens is inside the container; on the internal wall of the latter are visible burning traces produced by solar radiation. From [30]

In 1879 G. Stokes introduced a notable improvement in the part for the recording that has brought the use of the instrument up to the present day. (Figure 3B) [8], [21]. The instrument, which had a great diffusion, consists of a glass sphere, which operates as a converging lens, mounted concentrically to a spherical metal section. The diameter of the section is set such that the sunrays are focused on it during all the apparent daily motion of the Sun. On the metal section there are three guides placed at different heights on which a strip of chart paper is inserted, different for each season. When there is sunshine, the path of the Sun is marked on the strip, through the burnings due to the sunrays concentrated by the lens. The sum of the burning lengths on the chart paper indicates the daily sunshine. The instrument requires daily the manual replacement of the paper strip. [8].

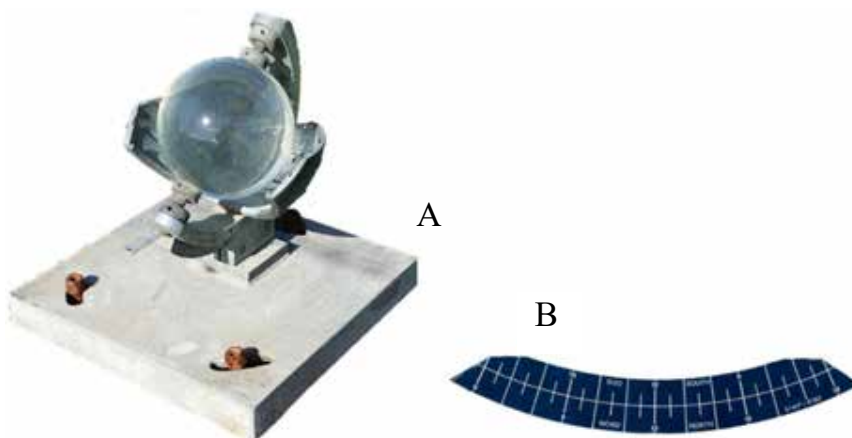

Figure 3.B - Campbell's sunshine recorder (A) with Stokes's support for chart paper (B), 1879. Photo by Gianni Fasano.

In 1888 J. B. Jordan, after design various prototypes, proposed a photochemical effect sunshine recorder. The instrument (figure 4) consisted of two semi-cylindrical chambers of blackened metal with an axis oriented parallel to the earth's surface and with a thin slit in the center of each one flat face. Strips of photosensitive paper were placed on the internal cylindrical surface of the boxes, so that the sunlight penetrated by the two slits left a mark. The boxes were arranged so that one was active in the morning hours and the other in the afternoon hours [21] [28].

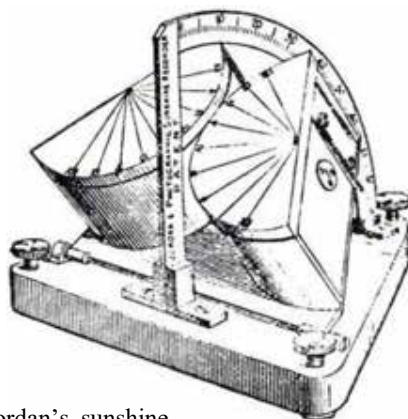

Figure 4 - Jordan's sunshine recorder (1888). From [21].

In the second half of the nineteenth century the *Arago actinometer* was developed. Although there is no reference to this instrument in the works of J. D. A. Arago, in his collection of scientific instruments H. Marié-Davy found a prototype. [10]. It is also known as the *Arago-Davy actinometer* since Marié-Davy used it for his measurements at the *Montsouris Observatoire* and described it in a work of 1875 [12]. The Arago actinometer, similar to the instrument described by Saussure, was not particularly precise as it was pointed out by several scholars as early as the beginning of the 20th century [3] [9]. In particular, the instrument suffered from a gradual decrease in sensitivity due to the loss of transparency of the glass casings where the thermometers were enclosed (about 20 % in 8 years) [9].

Towards standardization

In 1879 the Second International Meteorological Congress, held in Rome which led to the birth of the *Organization Météorologique Internationale* (OMI), established with regard to solarimetry that research on solar radiation was not yet sufficiently detailed to be able to propose adequate observation methodologies. In 1896 in Paris the OMI appointed a Commission for Solar Radiation with the task of establishing a standard for measuring instruments and procedures. In 1905 in Innsbruck, in the Third Conference of Directors of National Meteorological Services, it was decided to take as the reference standard the Ångström pyrheliometer (Figure 5), instrument still used today [2], [15].

Other instruments were designed and built in those years; in 1896 V. A. Michelson built a pyrheliometer more precise than Pouillet's, based on an ice calorimeter, but impractical to use. In 1908 Michelson made a bimetallic one with a thermocouple thermometer which, although calibrated with reference to a standard pyrheliometer, was much more easily transportable and usable [19].

In the following decades, different types of radiometers were designed to measure the other components of solar radiation (i.e. the pyranograph by M. Robitzsch in 1932) which started the built of instruments whose signal could be recorded analogically on a system of data acquisition (in general a chart recorder).

Figure 5 - Ångström's pyrheliometer (1893). In the current version, the instrument is a tube about 25 cm long, with an opening approximately equal to the solid angle within which the Sun with its halo can be seen from Earth. A: open end; B closed end. C and D gears to orient the instrument so that the end A is orthogonal to solar radiation. In figure, the orientation is manual, but the instrument can be equipped with a solar tracker to automate its continuous alignment with the Sun. Photo by Gianni Fasano.

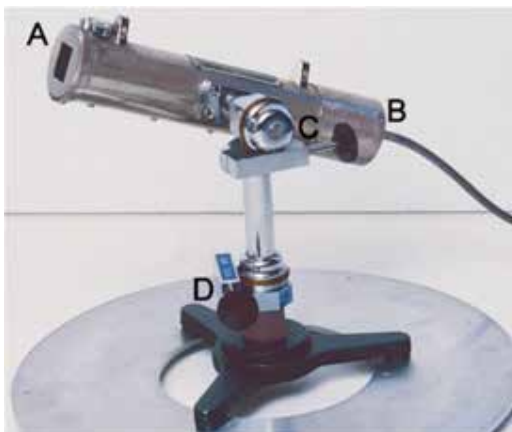

Figure 6 - Robitzsch's bimetallic pyranograph (1932): external view (A) and internal view (B). Photo by G. Fasano.

The Robitzsch pyranograph (figure 6), an instrument for measuring global radiation, had three bimetallic blades side by side as sensitive elements: the central one blackened and the side whitewashed. The blades were arranged so that the thermal deformations (due to solar heating) of the white ones acted on the movement of the pen, in the opposite direction to the action of the black blade. The recording took place on paper, mounted on a rotating drum and was traced by an ink pen. The instrument was equipped with a spring-loaded mechanical clockwork.

In the same period, pyranometers were made (figure 7) to measure the intensity of radiation through the electric potential difference generated by a Moll-Gorczynski thermopile, designed in the 1920s; other types were built using a photocell⁴ as a sensitive element. Versions of these instruments were made to measure the diffuse component of solar radiation where the only difference, with the apparatus for the global component, was that the sensor was shaded with a band that had to be adjusted every two to four days in relation to the season.

⁴ Photocell: electronic device, based on the photoelectric effect, which converts radiant energy (in solarimeters, solar energy) into electrical energy.



Figure 7 - Current version of pyranometer (Eppley model PSP, 1957): on left for global radiation; on the right the same instrument equipped with a shading band for the measure of diffuse radiation.

F. Albrecht, in the early 1930s, proposed a pyranometer (*pyrradiometer*), for the measurement of total solar irradiance (total solar radiation) [14] which had as its sensitive part a blackened thin metal disk surrounded by a coplanar ring; the two elements were connected by a thermoelectric battery composed by a series of elements of manganin-constantan thermocouples. The sensor was protected by a spherical cap inside which there is very rarefied dry air [26]. In the same period, for the measure of net solar radiation⁵, Albrecht designed a net pyranometer (*net pyrradiometer*) based on the same principles, but which used two blackened plates. In 1952 Hofmann proposed a modified version and later the measurement method, by means of two blackened and thermally insulated plates, was adopted for many of the modern net pyranometers [14].

OMI, WMO and networks of measurement stations

One of the first recommendations for radiometric measurements was given during the X meeting of the International Meteorological Committee (Rome, 1913) where it was established that *the measurement of the total radiation of the sun should be made regularly at least once a day at a suitable time, and on clear days as frequently as possible*. [25], [26].

In the Eighth Conference of Directors of the National Meteorological Services (Washington, 1947) it was recommended that each country should establish a network of stations for solar radiation measurements, in order to use for climatological purposes and in other applications [26]. At the same Conference it was recommended that the networks of agro-meteorological stations (their institution were discussed during the conference) should, as far as possible, continuously record data of global solar radiation, in particular within the photosynthetic bands of solar spectrum (Photosynthetically Active Radiation). These bands were specified as red-orange $0,60 \div 0,70 \mu\text{m}$, blue-violet $0,40 \div 0,50 \mu\text{m}$ and biological ultraviolet $0,29 \div 0,32 \mu\text{m}$. In addition, it was recommended to include sunshine duration measurement in any solar radiation observation scheme [26].

⁵ Net Radiation: radiative flux given by the difference between the radiation coming from the celestial vault and that arriving from the surface under consideration in the spectral range: $0,3 \div 60 \mu\text{m}$.

In general, the systematic measures of solar radiation began in the second half of the twentieth century. There are few considerable sets of radiometric data before 1950 [12]: only some series of radiometric data collected for short periods (maximum 7-10 years) in some parts of Europe and the Mediterranean basin were recovered. In the period between the two World Wars the most remarkable actinometric observations were conducted by Gorczynsky in Poland, France, and Tunisia.

The developments of the late Twentieth Century

The solarimeters in the second half of the twentieth century evolved from a technological point of view, but they used widely what had been previously designed as sensitive elements (thermopile, photocell, etc.). Technological development allowed to carry out measures in wider ranges of the solar spectrum, or in part of it (such as ultraviolet bands) which until then could not be investigated.

Starting from the last decades of the 1900s, digital recording instruments have also been developed for radiometry. Moreover, instruments have been built that drastically reduce maintenance operations, an essential aspect for measurements of quantities, such as sunshine and diffuse radiation, carried out in remote and difficult to reach sites.

For example, for the measure of sunshine duration, automated instruments have been designed that have photodiodes as a sensitive element. These instruments have a much more accurate time resolution, a much more precise threshold; they also eliminate the daily burden of replacing the chart paper strip as in Campbell Stokes' sunshine recorder.

About ten years ago, a multiparametric electronic radiometer was designed and built for routine measurements that do not require great precision. The instrument has several radiation sensors (photocells) and is equipped with a mask that, during the apparent movement of the Sun, shadows some sensors and others do not (Figure 8). In this way, the shaded sensors measure the diffuse radiation, the others the global one; with these two quantities the radiometer, through its own microprocessor with its own algorithm, calculates the sunshine duration. The instrument supplies three electrical signals outputs, corresponding to three measured quantities,



Figure 8 - Electronic radiometer for the measurement of global radiation, diffuse radiation, and sunshine duration. On left the instrument, on right the shadow mask.

thus allowing continuous recording. Another advantage is that the multiparameter radiometer does not need neither specific precautions for its installation nor periodic adjustments [8].

Solar Radiation and Human Health

In the last decades of the last century, the observation of the increase in ultraviolet (UV) radiation, which reaches the earth's surface, has led many authors to carry out studies on the biological effects that this phenomenon has on ecosystems and human health.

Until 2016, there was no reference standard for the calibration of radiometers for UV measure. Consequently, many existing instruments were not comparable to each other because they were calibrated with different reference systems. [22]. In 2016 the CIE (*Commission Internationale de l'Éclairage*) provided an international standard for the calibration of UV radiometers [20].

Biomedical research has concluded that exposure to solar ultraviolet (UV) radiation can have harmful effects on human health, in particular on the skin, eyes, and immune system [13]. Regarding safeguarding the health of outdoor workers, significant problem for activities in coastal and marine areas, it shows fundamental importance to have an estimate of UV radiation in order to establish the maximum exposure times.

Since in many standard weather stations UV-A (315 ÷ 400 nm) and UV-B (280 ÷ 315 nm) have not been measured, some researchers have carried out models based on artificial neural networks to estimate them starting from the values of the meteorological quantities, most commonly measure [7].

Radiometric measurements for marine and coastal environments

The possibility of life of animals and plants, which have as their habitat the coastal aquatic environment, is linked to the capacity of solar radiation to penetrate in the water column, in quantities and qualities that guarantee the metabolic activity of marine and lake organisms. Hence it is important to have instruments, spectroradiometers, for measuring the radiation that can penetrate sea water in its double quantitative and qualitative aspect depending on the thickness crossed.

Penetration, selective absorption of solar radiation and transparency of sea water are indicative of biological activity and suspended matter. *In situ* measurements of both transparency and water absorption can be carried out using instruments, such as the underwater radiometer and the Secchi disk, which measure the level of radiation reaching certain depths. The underwater radiometer records the intensity of radiation in the ultraviolet, visible and infrared ranges of the solar spectrum, down to the depth of a few hundred meters.

The Secchi disk is an instrument for measuring the transparency of the water column. This device was invented in 1865 by Father Angelo Secchi, who used it for the first time during a cruise of the *Immacolata Concezione* pirocorvette in the Mediterranean Sea. It is a circular disk, about 20÷30 cm in size, white or with alternating white and black dials. The disk, suitably weighted, is sunk by means of a cable on which marks corresponding to the depth are shown; the measure consists in detecting the depth at which the disk becomes barely visible. The greater is the depth value read, the greater is the transparency of the water.

Many underwater radiometers have been developed over the years, some with a unique spectral band [24], others with multiple bands, but very narrow [31], some finally providing a continuous spectrum [23]. These instruments, even the simplest ones, are characterized by a rather high cost; this is partly due to the fact that they provide the absolute value of the incident radiative power for the various wavelength ranges or for the different spectral lines.

Also in the 2000s, for studies concerning both physical and biological marine and oceanic quantities, devices were carried out for the qualitative and quantitative measurement of solar radiation that can penetrate, at different depths, into sea water [16]. For these kinds of studies, CNR-IBIMET designed and built a benthic chamber that allowed for metabolic measurements of the underwater flora. In particular, through SuMaRad (*Sub Marine Radiometer*, device designed by CNR-IBIMET, figure 9) the solar radiation in the water column was measured in the global, blue, green and red ranges, ranges indispensable to the life of underwater vegetation, [16] and by means of a multiparameter probe pH, temperature depth, conductivity and dissolved oxygen were detected [17].

The SuMaRad system measures underwater radiation, at different depths, in four spectral bands, not in absolute value but in ratio to the corresponding solar radiation (pure number between 0 and 1), in the same bands, at the sea surface. The considered spectral ranges are: global radiation (400 ÷ 1100 nm), red (590 ÷ 720 nm), and blue (400 ÷ 540 nm), that activate chlorophyll *a* and *b*, and green (480 ÷ 600 nm) that is absorbed by some active carotenoids [29]. The instrument indicates, in other words, the transmittance of the water by providing, in reference to the radiative energy that reaches the different depths, comparative data with respect to the energy external to the water.

A pressure sensor and a temperature sensor are installed inside the underwater radiometer, which give indications respectively on the depth and temperature of the measuring point. The operating depth of the instrument is 50 meters.



Figure 9 - SuMaRad and Benthic Chamber, during the installation phase on the seabottom of Cavo (Elba Island-Italy).
Photos by Gianni Fasano.

Conclusions

The history of the design and carried out of instruments for measuring solar radiation for meteorological purposes began only in the first half of the nineteenth century, although this quantity is the main engine of environmental physics and terrestrial biology. More recently, radiometric measurements have begun for research in marine and coastal environments and for studies on the effects of the various components of solar radiation on human health.

As with other instruments for environmental measures, with the standardization of the measurement procedures and with the unification of the new devices, the authorship of these instruments has been lost: the inventor is no longer there, the Campbell-Stokes sunshine recorder or the Robitzsch pyranograph are no longer there. Today there are companies that develop new, increasingly efficient and sophisticated, technological and design solutions whose authors remain anonymous.

Reference

- [1] AA.VV. (1908) - *L'Héliothermomètre de Saussure*, Bulletin de la Société Belge d'Astronomie, vol. 9, pp. XV-XVI
- [2] AA.VV. (1977) - *Scienza e tecnica dalle origini al Novecento*, volume II, edizioni EST, editore Mondadori, Milano
- [3] Alessandri C. (1908) - *La radiazione solare al Monte Rosa. Osservazioni eseguite alla Capanna-Osservatorio Regina Margherita 1905-1908*, Atti della Reale Accademia dei Lincei, Anno CCCV, Vol. XVII, 2° semestre, pp.58-60.
- [4] American Association for the Advancement of Science (1884) – *Notes and News*, in Science, pubbl. The Science Company Cambridge Massachusetts, vol. III, n. 64, p. 527
- [5] Barry R. G. (1978) - *H. B. De Saussure: the first Mountain Meteorologist*, Bulletin of the American Meteorological Society 59(6), pp. 702-705
- [6] Bellani A. (1836) - *Il Collettore del calorico ossia nuovo strumento meteorologico inventato e descritto da Angelo Bellani*, Annali delle Scienze del Regno Lombardo-Veneto, tomo VI, pp. 200-208
- [7] Benincasa F., De Vincenzi M., Materassi A. (2009) - *Stima della radiazione solare ultravioletta per mezzo di un modello neurale*, Italian Jour. Agrometeorology, 27-34 (3)
- [8] Benincasa F., De Vincenzi M., Fasano G. (2019) - *Storia della strumentazione meteorologica nella cultura occidentale*, CNR Edizioni, Firenze, DOI [10.26388/ibimet18](https://doi.org/10.26388/ibimet18)
- [9] Besson L. (1920) - *Sur les actinomètres d'Arago et de Bellani*, in Comptes Rendus des Séances de l'Académie des Sciences, ed. Gauthier-Villars, Paris, Tome 170, pp.851-854.
- [10] Besson L. (1928) - *Sur les actinomètres d'Arago*, Annales des Services Techniques de la Ville de Paris, Tome IX (1927), pp.149-166
- [11] Borchì E., Maciì R. (1997) - *Termometri e termoscopi*, Pubblicazioni dell'Osservatorio Ximeniano, Firenze
- [12] Bravo-Paredes N., Gallego M. C., Antón M., Núñez M., Vaquero J. M. (2019) - *Analysis of actinometric measurements under all-sky and cloud free conditions in Cáceres (Spain) for the period 1913–1920*, Tellus B: Chemical and Physical Meteorology, 71:1, 1-8, DOI: [10.1080/16000889.2019.1663597](https://doi.org/10.1080/16000889.2019.1663597)
- [13] Carboni D., Cervadoro E., Cervadoro G., De Vincenzi M., A. Faucci, Lolli I., Materassi A. (2010) - *Esposizione alla radiazione solare ultravioletta in ambiente costiero: valutazione*

- dei fattori di rischio*, Atti III Simposio Int. "Il Monitoraggio Costiero Mediterraneo: problematiche e tecniche di misura" Livorno 15-17 giugno 2010, CNR-IBIMET, pp. 690-703
- [14] Coulson K. (2012) - *Solar and Terrestrial Radiation: Methods and Measurements* Academic Press, New York, pp 334 DOI: [10.1016/B978-0-12-192950-3.X5001-3](https://doi.org/10.1016/B978-0-12-192950-3.X5001-3)
- [15] Fasano G., Materassi A., Zara P. (1999) - *Sensori e strumenti elettronici per la meteorologia*. Quaderno n. 8 Collana tecnico-scientifica INAPA, Firenze.
- [16] Fasano G., Materassi A. (2003) - *Progetto e realizzazione di uno strumento per la misura dell'assorbimento radiativo dell'acqua marina: SuMaRad*, Riv. di Ing. Agr. vol. 4: pp. 1-7, Ed. ETS
- [17] Fasano G., Materassi A., Benincasa F. (2010) - *Benthic chamber for metabolic measurements of underwater flora: a new realization*, Atti III Simposio Int. "Il Monitoraggio Costiero Mediterraneo: problematiche e tecniche di misura" Livorno 15-17 giugno 2010, CNR-IBIMET, pp. 559-566
- [18] Forbes J.D. (1841) - *Supplementary Report on Meteorology* in Report 10th Meeting of the British Association for the Advancement of Science held in Glasgow in august 1840, published by J. Murray, London, pp. 37-156
- [19] Fröhlich C. (1991) - *History of Solar Radiometry and the World Radiometric Reference*, Metrologia, 28, pp. 111-115, DOI: [10.1088/0026-1394/28/3/001](https://doi.org/10.1088/0026-1394/28/3/001)
- [20] Gugg-Helminger A. (2017) - *CIE 220:2016 – Characterization and Calibration Method of UV Radiometers*, IUVA News, vol.19 (2), pp. 18-23
- [21] Knowles Middleton W.E. (1969) - *Invention of Meteorological Instruments*, The Johns Hopkins Press, Baltimore, USA
- [22] Larason, T.C., Cromer, C. L. (2001) - *Sources of Error in UV Radiation Measurements*, Journal of Research of the National Institute of Standards and Technology, vol. 106, n.4, 649-656 DOI: [10.6028/jres.106.030](https://doi.org/10.6028/jres.106.030)
- [23] Licor (1984) - *LI-1800UW Underwater Spectroradiometer Instruction Manual*, technical report, <https://www.licor.com/env/support/MicroContent/Resources/MicroContent/li-1800uw-manual.html>
- [24] Licor (2006) - *LI-COR Underwater Radiation Sensors LI-192 Underwater Quantum Sensor LI-193 Spherical Quantum Sensor*, technical report <https://www.licor.com/documents/285ymmolackqjidu9wao>
- [25] OMI (1914) - *Report of the tenth Meeting of the International Meteorological Committee, Rome 1913*, Authority of the Meteorological Committee, London
- [26] OMI (1950) - *Provisional Guide to Meteorological Instrument and Observing Practice*, OMI n.78, Lausanne, Switzerland
- [27] Ranzi I. (1928) - *Una priorità italiana. L'attinometro a distillazione di Bellani*, Nuovo Cimento 5, pp.CXXIX–CXXXI (1928). DOI: [10.1007/BF03037266](https://doi.org/10.1007/BF03037266)
- [28] Rivosecchi I. (1975) - *Osservazioni e strumenti di meteorologia*, Vol. II, IFA DP n.5, ed. CNRIFA, Roma
- [29] Salisbury F.B., Ross C. W (1988) - *Fisiologia Vegetale*, Zanichelli Bologna
- [30] Science Museum Group. Campbell type sunshine recorder, used at Kew Obser. Science Museum Group Collection Online. <https://collection.sciencemuseumgroup.org.uk/objects/co55091> Accessed on 12th May 2020
- [31] Seabird (2018) - *OCR-500 Series Multispectral Radiometers*, technical report <https://www.seabird.com/multispectral-radiometers/multispectral-radiometers/family?productCategoryId=54627869938>
- [32] WMO (2018) - *Guide to Instruments and Methods of Observation, Volume I: Measurement of Meteorological Variables*, WMO n.8, Geneva, Switzerland

“FLEX 2018” CRUISE: AN OPPORTUNITY TO ASSESS PHYTOPLANKTON CHLOROPHYLL FLUORESCENCE RETRIEVAL AT DIFFERENT OBSERVATIVE SCALES

Annalisa Di Cicco¹, Remika Gupana^{2,3}, Alexander Damm^{2,3}, Simone Colella¹, Federico Angelini⁴, Luca Fiorani⁴, Florinda Artuso⁴, Vittorio Ernesto Brando¹, Antonia Lai⁴, Andrea Genangeli⁵, Franco Miglietta⁶, Rosalia Santoleri¹

¹CNR – Istituto di Scienze Marine (ISMAR), Via del Fosso del Cavaliere, 100 - 00133 Rome (Italy)
phone +39 06 49934508, e-mail: annalisa.dicicco@artov.ismar.cnr.it

²Eawag - Swiss Federal institute of Aquatic Science and Technology, Duebendorf (Switzerland)

³Department of Geography, University of Zurich, Zurich (Switzerland)

⁴Italian National Agency for New Technologies, Energy and Sustainable Economic Development (ENEA), Frascati - Rome (Italy)

⁵University of Florence (UniFi), Florence (Italy)

⁶CNR – Istituto per la BioEconomia (IBE), Florence (Italy)

Abstract – In frame of the European Space Agency’s (ESA) “FLEXSense Campaign 2018” and the Copernicus Marine Environment Monitoring Service (CMEMS) project, the Global Ocean Satellite monitoring and marine ecosystem study group (GOS) of the Italian National Research Council (CNR) organized the oceanographic cruise “FLEX 2018”. The CNR research vessel “Dallaporta” provided a ground station for several bio-optical instruments to investigate the coastal waters of the Tyrrhenian Sea (central Italy) in June 2018. The field measurements were performed in time synchrony with spaceborne (i.e. Sentinel 3A and Sentinel 3B satellites) and airborne (i.e. HyPlant airborne imaging spectrometer) observations, with the intent to contribute to calibration/validation activities for existing and future space mission developments. Particularly, active and passive fluorescence were investigated at different scales in aquatic ecosystems, to support preparatory activities of the FLuorescence EXplorer (FLEX) satellite mission to be launched in 2022. Results provide new insight on the sensitivity of Solar Induced Fluorescence (SIF) retrievals for atmospheric disturbances and other scale related aspects, and will eventually facilitate the implementation of robust retrieval schemes for the FLEX mission products. In addition, active fluorescence signals acquired from a LIDAR fluorosensor show a good agreement with SIF pattern retrieved by HyPlant and Sentinel-3 Ocean and Land Colour Instrument (OLCI). Our results demonstrate that the combination of active and passive fluorescence, together with the synergistic measurements from integrated platforms, is a promising approach to support the retrieval and interpretation of SIF in aquatic environments.

Introduction

Chlorophyll fluorescence is a fundamental proxy to provide physiological information and estimates of photosynthetic energy conversion efficiency. Long exploited in laboratory and field, the interest of the scientific community in remote sensing based fluorescence observations increased over the last years. Instruments adopting the Light Induced Fluorescence (LIF)

FUP Best Practice in Scholarly Publishing (DOI 10.36253/fup_best_practice)

Annalisa Di Cicco, Remika Gupana, Alexander Damm, Simone Colella, Federico Angelini, Luca Fiorani, Florinda Artuso, Vittorio Ernesto Brando, Antonia Lai, Andrea Genangeli, Franco Miglietta, Rosalia Santoleri., “Flex 2018” Cruise: an opportunity to assess phytoplankton chlorophyll fluorescence retrieval at different observational scales, pp. 688-697, © 2020 Author(s), CC BY 4.0 International, DOI 10.36253/978-88-5518-147-1.68

technique to remotely monitor actively stimulated fluorescence from dissolved and particulate sea water constituents have been widely employed for marine environment monitoring. [1]. In the recent years, large steps have been made also in the retrieval of passive Sun-Induced chlorophyll Fluorescence (SIF). In the framework of its Earth Observation Envelope Programme, the European Space Agency (ESA) is currently implementing the FLuorescence EXplorer (FLEX) satellite mission, the first mission specifically designed to monitor the photosynthetic activity of terrestrial vegetation. FLEX is scheduled to be launched in 2022 and comprises two spectrometers, the FLuorescence Imaging Spectrometer measuring in low (FLORIS-LR) and in high resolution (FLORIS-HR). Both sensors together cover the spectral range between 500 nm and 780 nm and provide a varying spectral sampling interval and resolution of up to 0.1 nm and 0.3 nm respectively, particularly in the Oxygen absorption bands (O₂B and O₂A) [2]. Considering the complexity of the targeted photosynthetic process, FLEX will be ESA's first mission designed as "tandem concept", flying in tandem with the Copernicus Sentinel - 3 satellite. This allows measuring all relevant data to facilitate subsequent estimates of photosynthesis [2].

Measurement campaigns providing detailed in situ observations from integrated platforms at different scales play a crucial role to develop, calibrate and validate data products of current and future satellite missions [3]. In this context, ESA organized the "FLEXsense campaign" in 2018 to facilitate preparatory activities for FLEX, particularly addressing the development of retrieval schemes and atmospheric correction approaches. The campaign specifically focused on the collection of hyperspectral data over monitoring sites in vegetation ecosystems such as agricultural and forest sites, and aimed to evaluate the potential applicability of FLEX data to assess coastal marine environments.

SIF retrieval in aquatic ecosystems has a great ecological value considering its potential in discriminating phytoplankton diversity and in improving productivity estimates. Particularly, in optically complex waters, characterized by active constituents with very different dynamics compared to open waters, the retrieval of SIF is a major challenge. McKee et al. [4] explored coastal waters with CDOM and TSM ranging from 0 m⁻¹ to 1 m⁻¹ and from 0 g m⁻³ to 10 g m⁻³ respectively, and found that increasing concentrations of CDOM and minerals can reduce the water-leaving SIF per unit chlorophyll by over 50 %. This suggests caution in the interpretation of SIF signals from coastal waters [4] and highlights the crucial role of the in-situ bio-optical characterizations for SIF retrievals and validation activities in aquatic ecosystems in general and coastal waters in particular. In this context, CNR-ISMAR organized in frame of the FLEXsense campaign the oceanographic cruise "FLEX 2018". The CNR research vessel "Dallaporta" provided a ground station for several bio-optical instruments that investigated the coastal waters of the Tyrrhenian Sea (central Italy) in June 2018. All the Apparent and Inherent Optical Properties (AOPs and IOPs) were estimated in addition to various physical ancillary data. These detailed in-situ measurements were complemented with concurrent radiometric observations acquired using the high-resolution airborne imaging spectrometer HyPlant [5] and both Sentinel - 3A and - 3B satellites.

The aim of this work is to assess whether SIF can be consistently retrieved using a simple retrieval scheme for in-situ, airborne and spaceborne measurements and if, in the framework of this integrated approach, TChla active fluorescence, less affected at 680 nm by other constituents, can be useful to improve the retrieval of passive fluorescence and the understanding of its behavior.

Materials and Methods

The “FLEX 2018” cruise took place between 5th and 7th of June 2018 in the Tyrrhenian Sea. Figure 1 shows the sampling plan of the cruise in the investigated area. The sampling strategy was optimized to facilitate the objectives of the “FLEXSense Campaign”.

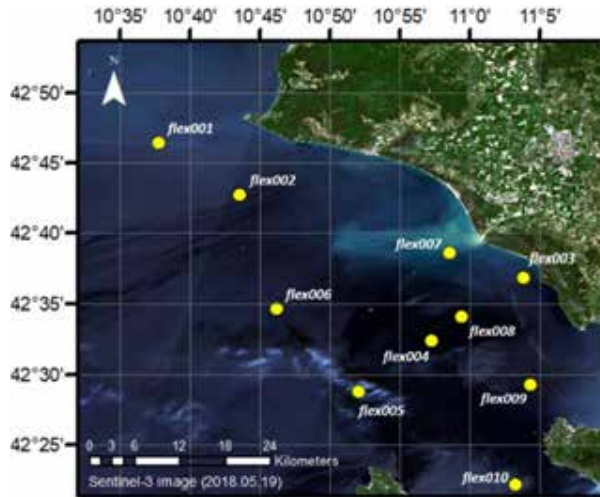

Figure 1 - FLEX 2018 in-situ sampling plan. Yellow circles indicate stations intensively characterized by in situ sensors. The background true color image was obtained by Sentinel-3.

For each measurement station, in-situ data for the determination of CDOM, algal and non-algal absorption coefficients (a_{CDOM} , a_{phy} and a_{NAP} respectively) and phytoplankton pigments and Total Suspended Matter (TSM) concentration were collected at the surface. Water was sampled by a horizontal hand Van Dorn bottle. For all parameters except CDOM, water was pre-filtered by a net with a mesh of 250 μm to eliminate the zooplankton component and different water volumes, dependent on the optical properties, were vacuum filtered through Whatmann GF/F glass microfiber filter (nominal porosity 0.7 μm). Samples for particle absorption and pigment concentration were stored in liquid nitrogen, while those for TSM were stored at -20 °C. CDOM filtrations were carried out by low pressure through 0.2 μm Nylon filters. Filtered water was stored in black Pyrex bottles at -4 °C until measurements have been performed in laboratory. With regard to the instruments and analysis methods, pigment concentrations were estimated by High Performance Liquid Chromatography (HPLC, Agilent 1260) implementing the method of [6]. The absorption measurements were carried out by a dual beam Lambda 19 Spectrophotometer (Perkin-Elmer), equipped with a 50 mm integrative sphere for the particulate only. Methods of [7] and [8] were adapted for estimates of dissolved and particulate material absorption respectively. The analysis of TSM concentration were carried out by a gravimetric method following the protocol of [9].

Continuous LIF measurements were carried out using a LIDAR fluorosensor system developed by the ENEA agency in collaboration with the INSIS company in frame of the Italian Regional Project “RIMA” and installed on the ship. The light source is a frequency-tripled Nd:YAG laser (355 nm) and the detection system combines a telescope, wavelength dependent beam splitters, interference filters and Avalanche PhotoDiodes (APDs) being more compact and robust than photomultiplier tubes. LIF data are corrected with respect to the solar background and normalized to the Raman signal collected at 405 nm (Raman Unit, R. U), making it insensitive to instrumental variations [1]. The fluorescence signal has also been calibrated as TChla and compared with TChla data obtained from VIIRS (Visible Infrared Imaging Radiometer Suite) on 8th June, the first satellite data available due to cloud cover on campaign days and retrieved by applying the regional MedOC4 algorithm [10].

Above water surface radiometric measurements were collected in 8 of the 10 stations sampled using the in-situ fluorescence spectrometer FLOX (jb-hyperspectral.com). Sampling activities took place in concurrence with HyPlant and Sentinel-3 scene acquisitions. The spectral characteristics of the three systems in terms of sampling interval and resolution are comparable (cf. jb-hyperspectral.com, [2], [5]). FLOX comprises two sensors to measure irradiance and radiance in high and low spectral resolution, comparable to HyPlant and FLEX sampling schemes, making this instrument a good candidate for the multi-scale assessment of SIF retrieval accuracy in coastal areas. However, the instrument needs to be reconfigured to facilitate the simultaneous acquisition of downwelling irradiance (E_d), upwelling radiance (L_u) and sky radiance (L_{sky}), the three quantities required by specific protocols for spectroradiometric observation in aquatic systems.

HyPlant data were acquired over a coastal area near the Ombrone River in a North-South oriented flight path up to roughly 20 km from the coastline on 6th of June. The original HyPlant spatial resolution (3 m) was resampled to 300 m to facilitate the comparison with Sentinel-3 data. Since Sentinel-3B data acquired during the cruise day was substantially cloud covered, we used Sentinel-3 L1A data from 10th of June 2018 instead.

SIF was retrieved from in-situ, airborne and spaceborne measurements in SNAP using the Fluorescence Line Height (FLH) algorithm, an established empirical algorithm that exploits radiances at and around the SIF emission in three spectral bands (for this work 665 nm, 681 nm and 709 nm). For more details on the algorithm approach, its general formula and the selected spectral bands see [11], [12], [13]. The FLH method is typically used in the open ocean since low signal from elastic scattering provides good resulting baseline curves [14], [15]. High TChla and TSM concentrations in optically complex waters could significantly affect FLH results due to a peak from the elastic reflectance overlapping with the fluorescence signal and therefore potentially contaminating fluorescence retrieval [11].

Results

The compositional variability of the IOPs in each station is shown in Figure 2 using ternary plots, which feature a_{CDOM} , a_{phy} and a_{NAP} at four characteristic wavelengths, 443 nm, 560 nm, 620 nm and 680 nm [16].

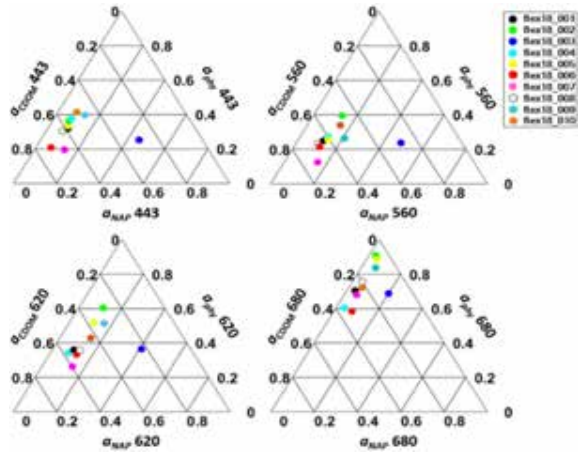

Figure 2 - Ternary plot showing the compositional variability of the IOPs in each station.

At 443 nm, where all three components absorb significantly, data show that in general the absorption budget is dominated by CDOM. Low values of a_{NAP} were found also at 560 nm (band usually governed by NAP absorption), except for station 3. The ternary plots at 620 nm and 680 nm indicate stations 2, 5 and 9 as the most characterized by phytoplankton absorption, also in terms of phycocyanin absorption (typical at 620 nm and proxy for cyanobacteria). All over the cruise, TChla and TSM concentrations range from 0.08 mg m^{-3} to 0.31 mg m^{-3} and from 0.13 g m^{-3} to 1.65 g m^{-3} , respectively. The relations between TChla and TSM and a_{CDOM} highlighted a more coastal feature for stations 3 and 7 (data not shown).

The relation between TChla concentration derived from HPLC measurements and FLH based – SIF values derived from FLOX (performed in 8 of the 10 stations) is shown in Figure 3 (left panel). On the right panel in Figure 3, the same relation but using LIF data detected from LIDAR in-situ acquisition is illustrated.

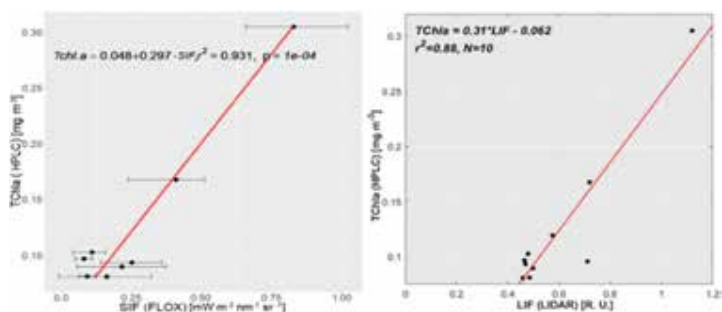

Figure 3 - In-situ estimates of TChl-a vs SIF (FLOX) and LIF (LIDAR).

For both in-situ instruments, derived fluorescence and TChla concentrations show a good agreement (i.e. $r^2 = 0.93$ and 0.88 , respectively). It must be noted that the correlation for the LIDAR is slightly lower due to the TChla value in station 10, while no FLOX measurements are available for this station.

FLH based SIF retrieved from HyPlant and Sentinel-3 data is shown in Figure 4.

When comparing the SIF data obtained from airborne and spaceborne in the corresponding swath, similar spatial patterns can be observed. Figure 5 (left panel) shows a comparison of SIF dynamics obtained from both sensors along a coast to offshore transect (black line in Figure 4). However, the range of SIF values calculated from HyPlant and Sentinel-3 differs significantly. In particular, SIF derived from Sentinel-3 FLH processing resulted in numerous negative values.

The spatial SIF pattern of from HyPlant and Sentinel-3 OLCI along the coast to offshore transect was also compared with the LIF signal (Figure 5, right panel), using the data overlapping with the airborne track (Figure 6, left). LIF signal shows a behavior comparable

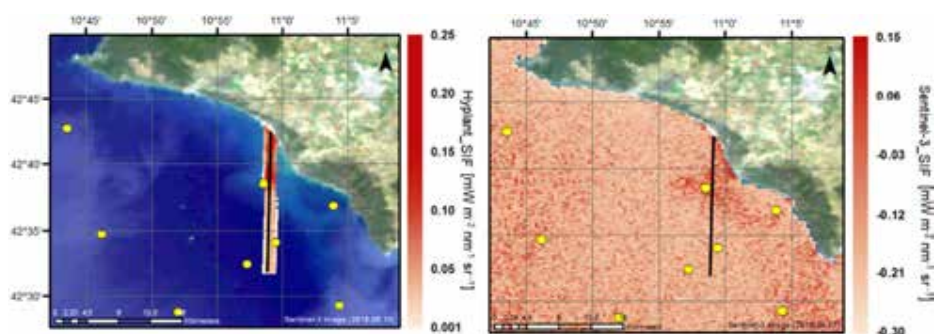

Figure 4 - SIF values calculated for the study area from HyPlant (left) and Sentinel-3A (right). The black N-S line indicates a transect used in Figure 5 (left panel).

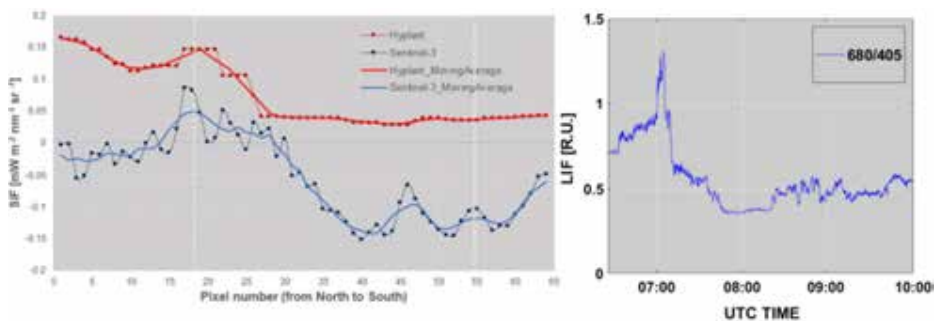

Figure 5 - SIF from HyPlant and Sentinel-3 OLCI from coast to offshore (dashed line with points) and smoothed profiles using a moving average approach. White dotted lines enclosed the pixels where HyPlant and LIDAR acquisition overlap (left). The corresponding LIF signal is shown to the right.

with the SIF obtained from the other two sensors, with increasing values in proximity of station 7 closer to the coast that gradually decrease and then stabilizes offshore. In the right panel of Figure 6, the LIDAR data collected during the whole cruise and calibrated in TChla is shown with respect to VIIRS TChla data.

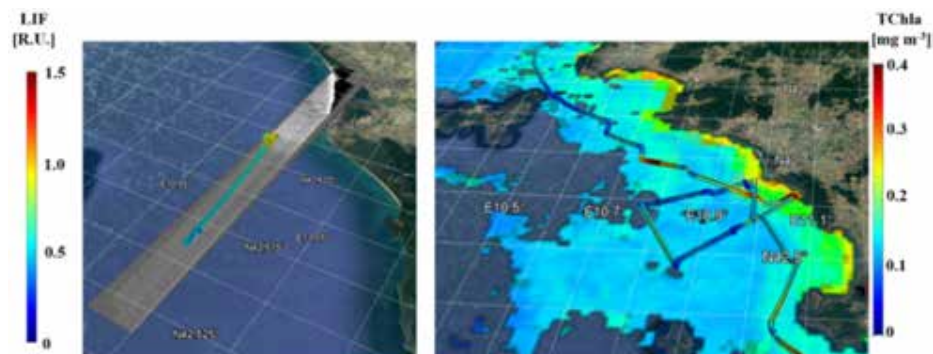

Figure 6 - On the left, LIDAR LIF data overlapping the HyPlant track and used in Figure 5. On the right, LIDAR data acquired over the all cruise (05 – 07 June) calibrated in TChla concentration and shown with respect to VIIRS TChla data related to the 8th of June.

Discussion

Based on the relative contribution of the three active constituents (i.e. phytoplankton, yellow substances, suspended material) to the total absorption, all investigated stations can be classified as complex waters dominated by yellow substances [17], except station 3 that is dominated by NAP. The ranges found for TChla and TSM concentrations and a_{CDOM} , suggest that the SIF retrieval based on the FLH approach could yield good results in this type of water. The evaluation of in situ SIF and LIF with TChla measurements (Figure 3) indicates a good positive correlation between both quantities. This finding corresponds with the known fact that higher phytoplankton biomass leads to higher fluorescence emissions. However, we only had a few sampling locations with most points dominated by low TChla concentrations and the linear regression is mainly driven by two points with higher fluorescence and TChla values. Future analysis would require more measurements and a sampling following gradients of chlorophyll concentrations, preferably closer to the shoreline, to properly account for the heterogeneity in this dynamic region. Further, only the upwelling radiance measurements from the FLOX were used for the FLH based SIF retrieval. It would be important to assess the impact of this configuration on the SIF-retrieval and advantageous to improve the FLOX design to facilitate standard aquatic measurement protocols.

SIF values derived from FLOX and HyPlant have similar magnitudes and trends but the SIF maximum from FLOX is four times that from HyPlant. This divergence can be possibly, among other effects, attributed to a missing atmospheric correction of HyPlant data. We also observe comparable spatial pattern between the airborne and spaceborne based SIF retrievals, with a coast to offshore gradient (Figure 4 and Figure 5, left). The same gradient

is also evident in the LIF data (Figure 5, right and Figure 6, left). This expected behavior is caused by the gradient in biomass that decreases with the distance from the coast. This is also confirmed by the TChla values found in the two sampling stations that fall into the HyPlant acquisition area, station 7 (more coastal) and 8. SIF and LIF values were also affected by the discharge coming from Ombrone River, which coincides with the higher FLOX based SIF values calculated especially near the river delta and the peak in SIF and LIF values between 15-25 pixels in Figure 5. The influx of additional constituents, particularly of algae and nutrients, contributes to an increased biomass concentration and thus a higher SIF and LIF signal in coastal waters surrounding the river outflow and in correspondence with station 3, the most coastal station, where the highest in-situ SIF and LIF values and TChla concentrations were obtained. Despite the common spatial pattern, however, the range of SIF values calculated from HyPlant and Sentinel-3 data substantially differ (Figure 5). The numerous negative values from Sentinel-3 FLH retrieval is likely due to the relatively low TChla concentrations in the study area. Perhaps the main reason for the difference in HyPlant and Sentinel-3 SIF results is the detection limit of Sentinel-3 OLCI due to its SNR combined with unfavourable atmospheric conditions. A similar study [18], using FLH in oligotrophic waters, showed good results for field data set but negative values from MERIS. The authors attributed this result to MERIS detection limited which appears to also be applicable for Sentinel-3 OLCI in this case. It must be noted that we did not account for effects of optically shallow waters, adjacency effects and stray light in our calculations, which could also affect the results obtained.

Conclusion

We conclude that the FLH approach is effective in measuring SIF in our study area, but further investigations to assess the general suitability of this method for different water types is important, e.g. by extending our approach to a wider range of optically complex waters that are typical of coastal regions. Particularly, at higher TChl-a concentrations (5 mg m^{-3} to 7 mg m^{-3} [4], [19]) and TSM concentrations, the apparent SIF peak observed at 685 nm appears to “shift” to a longer wavelength due to overlapping of SIF emission region and strong elastic scattering in the NIR [20]. Since such elevated concentrations are common in coastal and inland waters, especially during algal bloom events in spring and summer, refinements of the standard FLH approach are possibly needed to avoid a violation of method inherent assumptions. We suggest to consider more sophisticated retrieval schemes based on high spectral resolution data to possibly define more robust strategies to disentangle SIF from non-SIF signals.

Our results indicate that consistent SIF retrievals from in situ to airborne and satellite platforms are possible in relative terms and obtained spatial pattern are expected for coastal areas [21], [22]. Absolute differences in retrieved SIF across scales, however, require further investigations. Our approach allows to set priorities for the refinement of further pre-processing (e.g. implementation of more sophisticated atmospheric correction schemes) and to understand possible future limitations of retrieving SIF due to SNR.

The good agreement between active LIF signals from LIDAR fluorosensor and passive SIF values retrieved from FLOX, HyPlant and Sentinel-3, demonstrates how the connection between active and passive fluorescence, combined with measurements from integrated platforms, can be a promising approach supporting the development and evaluation of SIF retrieval approaches and contributing to phytoplankton fluorescence interpretation.

Acknowledgments

HyPlant data acquisition was funded by the European Space Agency in frame of the FlexSense project (No. ESA RFP/3-15477/18/NL/NA). We would like to thank the HyPlant team (PI Prof. Dr. Uwe Rascher, Research Centre Julich) for operating the instrument, acquiring and pre-process data. We thank the team of JB-Hyperspectral for providing a FLOX spectrometer system and Paul Nätke for assistance in installing the FLOX instrument on the research vessel. We also want to thank all the CNR researchers, technicians and students involved in the “FLEX 2018” cruise organization and in the field sampling activities.

References

- [1] Palucci, A., Nuvoli, M., Colao, F., Angelini, F., & Fiorani, L. (2018) - *Laser radars for marine monitoring*. In 22nd International Symposium on High Power Laser Systems and Applications, HPLS and A 2018 (Vol. 11042). SPIE.
- [2] Drusch, M., Moreno, J., Del Bello, U., Franco, R., Goulas, Y., Huth, A., ... & Nedbal, L. (2016) - *The fluorescence explorer mission concept—ESA's earth explorer 8*. IEEE Transactions on Geoscience and Remote Sensing, 55(3), 1273-1284.
- [3] Cendrero-Mateo, M. P., Wieneke, S., Damm, A., Alonso, L., Pinto, F., Moreno, J., ... & Cogliati, S. (2019) - *Sun-induced chlorophyll fluorescence III: Benchmarking retrieval methods and sensor characteristics for proximal sensing*. Remote Sensing, 11(8), 962.
- [4] McKee, D., Cunningham, A., Wright, D., & Hay, L. (2007) - *Potential impacts of nonalgal materials on water-leaving Sun induced chlorophyll fluorescence signals in coastal waters*. Applied optics, 46(31), 7720-7729.
- [5] Rascher, U., Alonso, L., Burkart, A., Cilia, C., Cogliati, S., Colombo, R., ... & Hyvärinen, T. (2015) - *Sun-induced fluorescence—a new probe of photosynthesis: First maps from the imaging spectrometer HyPlant*. Global change biology, 21(12), 4673-4684.
- [6] Wright, S. W., Jeffrey, S. W., Mantoura, R. F. C., Llewellyn, C. A., Björnland, T., Repeta, D., & Welschmeyer, N. (1991) - *Improved HPLC method for the analysis of chlorophylls and carotenoids from marine phytoplankton*. Marine ecology progress series, 183-196.
- [7] Tassan, S., & Ferrari, G. M. (2002) - *A sensitivity analysis of the 'Transmittance–Reflectance' method for measuring light absorption by aquatic particles*. Journal of Plankton Research, 24(8), 757-774.
- [8] Ferrari, G. M. (2000) - *The relationship between chromophoric dissolved organic matter and dissolved organic carbon in the European Atlantic coastal area and in the West Mediterranean Sea (Gulf of Lions)*. Marine Chemistry, 70(4), 339-357.
- [9] Van der Linde, D. W. (1998) - *Protocol for determination of total suspended matter in oceans and coastal zones*. JRC Technical Note I., 98, 182.
- [10] Volpe, G., Santoleri, R., Vellucci, V., d'Alcalà, M. R., Marullo, S., & d'Ortenzio, F. (2007) - *The colour of the Mediterranean Sea: Global versus regional bio-optical algorithms evaluation and implication for satellite chlorophyll estimates*. Remote Sensing of Environment, 107(4), 625-638.
- [11] Gilerson, A. A., & Huot, Y. (2017) - *Bio-optical Modeling of Sun-Induced Chlorophyll-a Fluorescence*. In Bio-Optical Modeling and Remote Sensing of Inland Waters (pp. 189-231). Elsevier.

- [12] Gower, J. F., Brown, L., & Borstad, G. A. (2004) - *Observation of chlorophyll fluorescence in west coast waters of Canada using the MODIS satellite sensor*. Canadian Journal of Remote Sensing, 30(1), 17-25.
- [13] Abbott, M. R., & Letelier, R. M. (1999) - *Algorithm theoretical basis document chlorophyll fluorescence (MODIS product number 20)*. NASA (<http://www.modis.gsfc.nasa.gov/data/atbd>).
- [14] Huot, Y. (2005) - *Sun-induced fluorescence of phytoplankton in the ocean: Linking physiology and remote sensing*.
- [15] IOCCG (2006) - *Remote Sensing of Inherent Optical Properties: Fundamentals, Tests of Algorithms, and Applications*. Lee, Z.-P. (ed.), Reports of the International Ocean-Colour Coordinating Group, No. 5, IOCCG, Dartmouth, Canada.
- [16] Ogashawara, I., Mishra, D. R., & Gitelson, A. A. (2017) - *Remote sensing of inland waters: background and current state-of-the-art*. In Bio-optical modeling and remote sensing of inland waters (pp. 1-24). Elsevier.
- [17] IOCCG (2000) - *Remote Sensing of Ocean Colour in Coastal, and Other Optically-Complex, Waters*. Sathyendranath, S. (ed.), Reports of the International Ocean-Colour Coordinating Group, No. 3, IOCCG, Dartmouth, Canada.
- [18] Gons, H. J., Auer, M. T., & Effler, S. W. (2008) - *MERIS satellite chlorophyll mapping of oligotrophic and eutrophic waters in the Laurentian Great Lakes*. Remote Sensing of Environment, 112(11), 4098-4106.
- [19] Moreno-Madrinán, M. J., & Fischer, A. M. (2013) - *Performance of the MODIS FLH algorithm in estuarine waters: a multi-year (2003–2010) analysis from Tampa Bay, Florida (USA)*. International journal of remote sensing, 34(19), 6467-6483.
- [20] Gilerson, A., Zhou, J., Hlaing, S., Ioannou, I., Schalles, J., Gross, B., ... & Ahmed, S. (2007) - *Fluorescence component in the reflectance spectra from coastal waters. Dependence on water composition*. Optics Express, 15(24), 15702-15721.
- [21] Gilerson, A., Zhou, J., Hlaing, S., Ioannou, I., Gross, B., Moshary, F., & Ahmed, S. (2008) - *Fluorescence component in the reflectance spectra from coastal waters. II. Performance of retrieval algorithms*. Optics express, 16(4), 2446-2460.
- [22] Gower, J., & King, S. (2007) - *Validation of chlorophyll fluorescence derived from MERIS on the west coast of Canada*. International Journal of Remote Sensing, 28(3-4), 625-635.

CAREENING AREAS IN MARINAS, ANCHORAGES, AND PRIVATE SHIPYARDS. STATUS OF IMPLEMENTATION OF THE MSFD MEASURE

Julie Droit¹

¹CEREMA eau, mer et fleuves. Institute for risks, environment, mobility and development. 155 rue Pierre Bouguer, BP 5, 29280 Plouzané, FRANCE.

Phone: +33-(0)2 98 05 67 32 E-mail: julie.droit@cerema.fr

Abstract – Ship careening, which consists of stripping an antifouling paint by various techniques, generates waste, in the form of dust or flakes, which can contaminate the marine environment by runoff or by air. These residues contain different chemical contaminants (biocides, hydrocarbons, microplastics, solvents ...) that can have an impact on the environment and human health.

The implementation of the Framework Directive Marine Environment Strategy has been declined through the adoption of the Marine Environment Action Plans at the level of each marine sub-region, and then associated measurement programs. These include all concrete and operational actions that meet one or more environmental objectives, with a view to achieving or maintaining the good ecological status of marine waters by 2020.

An action on the fairing areas is part of the measures implemented at the national level: The M013 – NAT2 measure: Conduct a census of fairing areas of marinas, incite demarcation and the sharing of fairing areas and promote the elimination of discharges of contaminants into the sea.

In this context, the Cerema was commissioned by the Department of Water and Biodiversity of the Ministry of Ecological and Solidarity Transition to carry out a national study identifying the level of equipment in fairing areas of marinas, anchorages and private shipyards to assess their respect for the environment.

Data collected through surveys of managers, state agencies and public institutions concerned, are the subject of a layer of geographic information posted on the site Geolittoral: <http://www.geolittoral.developpement-durable.gouv.fr>

Introduction

Ship careening, which consists of stripping an antifouling paint by various techniques, generates waste, in the form of dust or flakes, which can contaminate the marine environment by runoff or by air. These residues contain different chemical contaminants (biocides, hydrocarbons, microplastics, solvents ...) that can have an impact on the environment and human health [1].

The implementation of the Framework Directive Marine Environment Strategy has been declined through the adoption of the Marine Environment Action Plans at the level of each marine sub-region, and then associated measurement programs. These include all concrete and operational actions that meet one or more environmental objectives, with a view to achieving or maintaining the good ecological status of marine waters by 2020.

An action on the fairing areas is part of the measures implemented at the national level:

The M013 – NAT2 measure: Conduct a census of fairing areas of marinas, incite demarcation and the sharing of fairing areas and promote the elimination of discharges of contaminants into the sea.

In this context, the Cerema was commissioned by the Department of Water and Biodiversity of the Ministry of Ecological and Solidarity Transition to carry out a national study identifying the level of equipment in fairing areas of marinas, anchorages and private shipyards to assess their respect for the environment.

Materials and Methods

Synthesis of existing data

Before soliciting the port managers, an inventory of existing data was carried out. Data have been collected from various bodies and state departments: Water agencies, French biodiversity office, relevant state bodies. A synthesis of the data available in the studies published on the subject was also carried out [2].

Online surveys

The contact details of the managers of the public and private refit areas were identified from the data synthesis and via internet searches.

An online questionnaire was constructed targeting the essential parameters for the study:

- accommodation capacity,
- type of area,
- fairing capacity,
- commitment to a certification or other exemplary approach,
- existence of a system for treating fairing effluents,
- type of treatment.

The questionnaire and all of the data collected were submitted to the relevant government departments for validation.

Following the first online survey, a complementary online survey was sent to managers who agreed to be contacted and who have a system for treating fairing effluents.

This second survey made it possible to obtain additional information concerning:

- the modalities of access to the fairing device,
- the periods of attendance,
- the methods of maintenance and control of the efficiency of the effluent treatment devices,
- the management of waste related to fairing activity (including bio-waste).

Classification criteria for ports, anchorage areas and boatyards

In order to describe the level of equipment of each site a color code has been adopted:

Table 1 - Color code applied to the data relating to the fairings.

Color	Code	Fairing activity?	Fairing area ?	Fairing area project ?	Sharing solution ?	Type of treatment known ?
White	0	no	no	/	/	/
Red	1	yes	no	no	no	/
Orange	2	?	? or no	?	?	?
Yellow	3	/	no	yes	/	/
Purple	4	/	no	no	yes	/
Green	5	yes	yes	/	/	no
Blue	6	yes	yes	/	/	yes



A "fairing area" (or « careening area ») is defined as a site (hold or land) equipped with a fairing effluent treatment system.

When the type of treatment is known, it is described as follows:



- **level 1 treatment:** Pre-treatment of effluent sludge / settler / oil separator. This pretreatment reduce the contents of suspended solids, hydrocarbons and oils. Micro-pollutants, including biocides, are not treated.



- **level 2 treatment:** Complete process : Pretreatment + filtration treatment (zeolite, activated carbon). This complete treatment system treat micropollutants (including biocides).

Results

Results of the first online survey

The questionnaire was sent to 600 harbor and mooring area managers and 400 managers of private boatyards.

Managers for whom no email address could be identified could not be contacted.

A total of 321 complete responses were recorded:

- 33.6 % of the requested port or anchorage area managers replied;
- 13.6 % of the managers of nautical shipyards contacted replied.

It should be noted that several managers have sometimes been identified for the same structure. Several responses were therefore sometimes received for the same site.

The actual response rates to the survey are therefore as follows:

- Ports and anchorage areas: 26 %
- Nautical sites: 8 %

The types of managers who responded to the survey are illustrated in the figure 1.

Given the difficulties encountered in identifying managers of private boatyards and their low response rate, data concerning them is scarce.

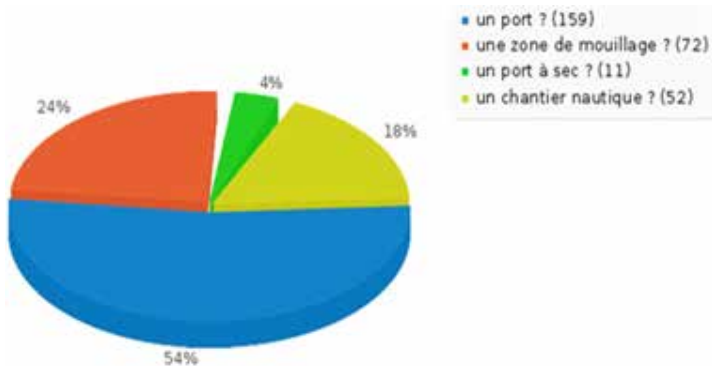

Figure 1 - Types of managers who responded to the online fairing survey.

Complementary online survey

Out of 99 managers contacted, including 81 ports, 29 complete responses were received. Or a response rate of 29 %.

According to these answers, the peaks of frequentation of the fairing areas are located between March and June:

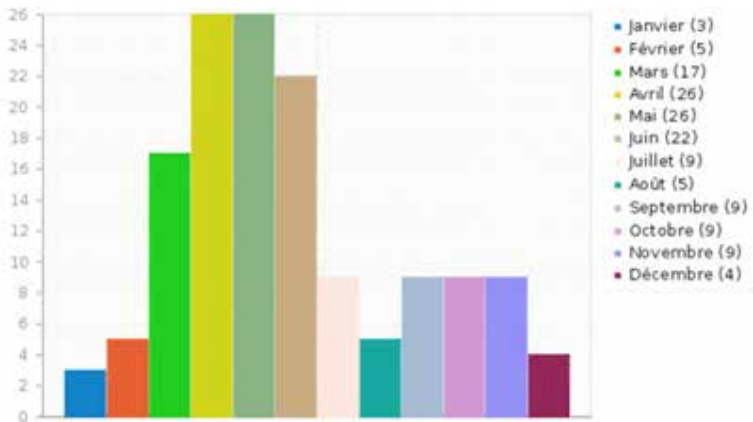

Figure 2 - Peaks in the use of fairing areas in mainland France.

41 % of the fairing area managers carry out self-checks of their treatment devices. These self-checks are always carried out at the point of discharge, and for only 25 % to 30 % of them, at the level of the sediments located at the level of the discharge or at the inlet of the treatment system.

For 30 % of the managers interviewed, the maintenance operations of the fairing installations consist of:

- clean and rinse the fairing surface,
- clean the grids upstream of the treatment systems,
- empty the tanks.

Only 20 % clean the filters, and 17 % replace them. Simple maintenance operations such as rinsing the surface, or cleaning the grids, are generally carried out by port operators, even by boaters. More complex maintenance operations such as emptying the tanks and cleaning the filters are delegated to specialized companies.

Finally, only 24 % of managers interviewed indicated that they were equipped with hazardous waste collection devices (oils, batteries, paint drums, solvents, etc.) at their refit area, and very few of them (13.8 %) have biowaste management channels from fairings.

Data on-line and updating methods

A Geographic Information System (GIS) has been produced as part of the data exploitation.

The purpose of this GIS is to make the data available to the public and to enable government departments to have a tool for diagnosing installations and analyzing needs, which they can then update.

This GIS will allow spatial analyzes on:

- the capacity of ports and anchorage areas,
- whether or not there is a fairing area,
- pooling of equipment,
- projects for the creation or upgrading of fairing areas,
- the level of activity of the fairing areas,
- the location of the discharge from the fairing areas,
- the type of treatment: level 1 (pretreatment) or level 2 (complete treatment).

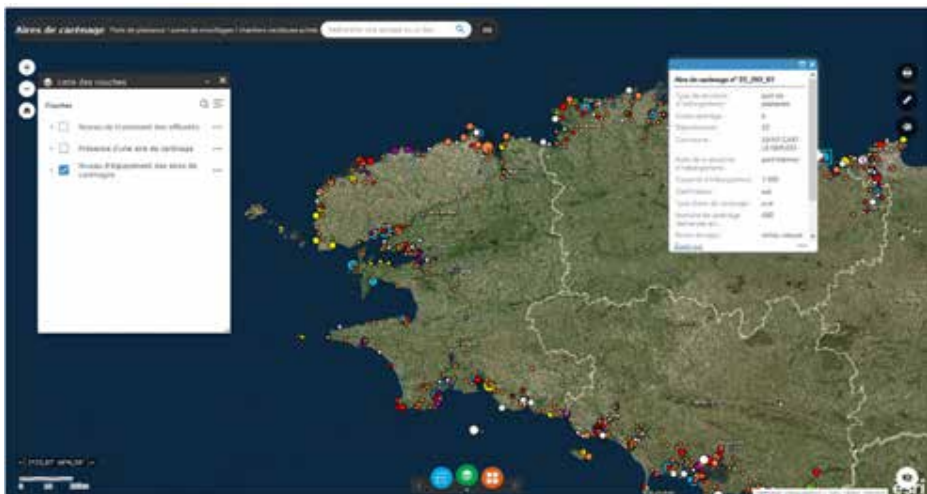

Figure 3 - Extract from the GIS fairings on Géolittoral.

Data will be made available via the national Géolittoral portal: <http://www.geolittoral.developpement-durable.gouv.fr>

Géolittoral is the data portal on the sea and the coastline of the Ministry in charge of the environment and the sea. It disseminates the geographic data produced within the framework of the fulfillment of public policies carried by the Ministry and is intended to cover all of France's maritime and coastal areas.

The data will be updated once a year by the Water Police Services while keeping a check step by Cerema.

Discussion

In addition to the updates that will be carried out annually by the Water Police services, the database could be supplemented by the following actions:

- Additional information could be collected via telephone surveys supplemented if necessary by field visits, in particular for large capacity ports;
- The GIS could be improved by the geolocation of all the mooring areas;
- The location of nautical sites could also be improved.

Data from the Port Sediment Quality Monitoring Network, the REPOM, could be analyzed in order to identify possible contamination of the receiving environment by contaminants that may be present in the fairing discharges (TBT, Cu, Zn, etc.).

Conclusion

The GIS fairing will allow the State services to define priority sites for:

- upgrading of installations,
- the creation of a fairing area,
- the implementation of innovative alternative solutions,
- the search for equipment pooling solutions.

However, upgrading treatment facilities is only part of the solution. Actions must also be taken:

- to develop practices by raising the awareness of port managers and boaters;
- to promote regular maintenance of treatment systems [3], [4].
- and finally, to act at the source of the problem by finding alternatives to antifouling paints with biocides.

Acknowledgments

Thank you to Cerema teams (Eau, Mer et Fleuves, Normandie-Centre, Ouest, Nord-Picardie, Sud-Atlantique and Méditerranée) for their participation in the survey and their help in carrying out the GIS and putting it online.

References

- [1] Loire Bretagne Water Agency (2015) - *Specifications for carrying out pollution measurements on refit sites.*
- [2] Loire Bretagne Water Agency (2015) - *The fairing areas of private nautical sites. Presentation of the Blue Wave collective operation.*
- [3] Marine Protected Areas Agency, Iroise Marine Natural Park, IDHESA (2011) - *Summary report on the monitoring of anti-fouling paints in port and anchorage areas.*
- [4] French Federation of Marinas (FFPP) (2003) - *Guide to recommendations for the design, construction and management of a technical and fairing area.*

ELECTROCHEMICAL PHOSPHATE DETECTION IN OLIGOTROPHIC SEAWATER WITH A STAND-ALONE PLASTIC ELECTRODE

Federico Figueredo¹, Federico Girolametti², Silvia Illuminati², Cristina Truzzi²,
Anna Annibaldi², Sabina Susmel^{1*}

¹Department of Agricultural, Food, Environmental and Animal Sciences-Di4A, University of Udine,
Via del Cotonificio 108, 33100 Udine (Italy), phone +39 0432558823,
e-mail: sabina.susmel@uniud.it

²Department of Life and Environmental Sciences, Università Politecnica delle Marche, Ancona (Italy)

Abstract – Nitrogen, phosphate and silicon are the main nutrient limiting and stimulating the planktonic primary production. Phosphate can vary from nanomolar to micromolar levels in ocean waters. However, oligotrophic systems are characterized for having nanomolar concentrations of phosphate, nitrogen and silicon. The northern Adriatic Sea is a particular water system, in which the levels of nutrients are commonly low or unbalanced with an abundance of nitrogen inflow both from rivers and water runoff being probably behind several eutrophication events previously reported. Laboratory methods and classical analytical equipment can be used to detect nutrient levels (in particular phosphate) with high precision and sensitivity, however, they are expensive, time cost and lack in portability. So there is a great need to develop analytical systems or new methods to detect nitrate, phosphate and silicon in oligotrophic seawaters as early diagnosis and in-field of the quality of the sea water. In general, phosphate detection can be done with the classical molybdenum-blue method. However, the method cannot be used in oligotrophic seawater samples due to its low sensitivity and high interference problems. Electrochemical methods are often proposed for in field detection to overcome some of the drawbacks as turbidity of the sample and optical interferences. In this study, we present a new method, characterized by the advantage of both simplicity and low cost, based on the application of a plastic conductive electrode containing a molybdenum reagent embedded. The original non-conventional electrode was characterized by surface electron microscopy, energy dispersive X-ray analysis and electrochemical methods. The sensitivity obtained for phosphate detection was high enough to detect this nutrient in oligotrophic seawater systems.

Introduction

The northern Adriatic is the slope region from the Venice-Trieste shoreline to the line connecting Ancona, on the Italian side, of Zadar, on the Croatian coast [1]. It is a semi-enclosed basin with limited water circulation and smoothly flow current being strongly influenced by fresh-water discharge from rivers (as Po in Veneto and Isonzo in Gulf of Trieste). Particularly, phosphate, the available form of phosphorous (P) is essential to all life forms, however, in high concentration induces eutrophication (10 ppb of phosphate is a concentration high enough) [2]. Excessive nutrients inflow of phosphorous as well as nitrogen, is typically consequence of industrial, agricultural or domestic waste runoff [3]. With the aim of environmental protection, water policies set limits for nutrients including phosphate

(i.e. 2 ppm in treated urban wastewater) [2]. However, oligotrophic conditions are now noticed in the northern Adriatic. In fact, if in central and southern Adriatic a low nutrient concentration on shallow waters has been detected, in the northern area the nutrient profiles are characterized by high surface concentrations of nitrates, vertically decreasing down to a depth of about 5–10 m, while an opposite trend of the salinity distribution indicates the influence of the Po river inputs. Despite this large river input, the northern Adriatic basin has been proved to be phosphorus limited. The cyclonic circulation effect driving nitrate rich waters southward determines a horizontal gradient of this nutrient, with high levels decreasing from west to east. This pattern is not present for phosphate, which show increasing levels in the centre of the basin, with high coastal depletion due to an intense phytoplankton activity [4].

For these reasons within the framework of the European project “AdSWiM, Managed use of treated urban wastewater for the quality of the Adriatic Sea”, a study on nutrients level and ratio is in progress.

In the analytical field, electrochemical sensors [5, 6] and biosensors are proposed since they are less affected by interferences, can be miniaturized and adapted for on-site detection. The standardized method for DIP detection is based on the colour change of a phosphomolybdate complex, commonly known as molybdenum-blue method. This method is not practical for in field detection since the reaction between the molybdate anions (from a molybdate ion stock solution) and the DIP is accomplished in solution and involve an incubation step for at least 30 min. In particular, for surface seawater samples, molybdenum-blue method is not sensitive enough. In this study, as a first approach for the electrochemical DIP sensor development, a plastic electrode based on graphite, PVC [7] and molybdate anions was prepared. Before the electrode preparation, Northern Adriatic surface waters were characterized and the nutrient levels were quantified during an entire season by classical instrumental approaches. Once the nutrient level baseline was determined, the electrode was prepared and optimized to be used as a phosphate sensor.

Material and methods

Spectrophotometric determinations were done to determine the level nitrate, nitrite, ammonium, phosphate, silicate and dissolved organic phosphate (DOP) in different sites of northern Adriatic (Fig. 1). Nutrients were analysed with a UV-VIS spectrophotometer (Systea EASYCHEM Plus) using standardized method to detect nitrite (EPA Method # 354.1), nitrate (EPA Method # 354.1), ammonia (APHA Standard Methods for the Examination of Water and Wastewater 4500 NH₃ G Automated Phenate Method), silicon (APHA Standard Methods for the Examination of Water and Wastewater 4500 SiO₂) and orthophosphate (ISO 15923).

Tetrabutylammonium octamolybdate (TBA₄Mo₈O₂₆) is a molybdate polyoxometal derivative soluble in non-aqueous solvents that can be synthesized starting from a commercial salt of molybdate. The synthesis procedure was based on the protocol published by Klemperer (1990) [8]. Briefly, 1 g of Na₂MoO₄·2H₂O was dissolved in 2 mL of distilled water. Then, 1 mL of HCl 6M was added when it was stirring in a 10 mL baker. After 10 min, 2 mL of a solution containing 0.78 g of tetrabutylammonium bromide was added and a white precipitate was obtained. The solution was collected in a porosity filter with suction and washed with 20 mL of distilled water, 20 mL of ethanol, 20 mL of acetone and 20 mL of

diethyl ether. The air-dried product was then dissolved in 40 mL of acetonitrile and cooled at -20°C . After 24 h a colorless crystalline powder was obtained.

The plastic electrode containing octamolybdate anions (Mo-PE), was prepared following our previously reported procedure [7] with minor modifications. Briefly, 200 μL of acetonitrile is used to dissolve 10 mg of $\text{TBA}_4\text{Mo}_8\text{O}_{26}$. The $\text{TBA}_4\text{Mo}_8\text{O}_{26}$ solution is mixed with 10 mL THF and then is drop into a 25 mL baker containing 380 mg of synthetic graphite, 50 mg of PVC and 50 μL of BEA. After stirring for 30 min at room temperature, the homogeneous slurry is transferred into a glass tray (6 x 6 cm) and allowed to dry overnight under the wood at room temperature. A double sided tape was used to stick the upper side of the obtained conductive material with a PET film (150 μm) and a paper punch was used to cut the material and obtain the Mo-PE. Electrodes prepared with 10 mg of $\text{TBA}_4\text{Mo}_8\text{O}_{26}$ was named as Mo-PE.

All electrochemical measurements were carried out with Gamry Reference 3000 potentiostat/galvanostat (USA). A graphite bar and $\text{Ag}/\text{AgCl}/\text{KCl}$ (3M) electrodes were used as counter and reference electrodes, respectively.

Results

Preliminary spectrophotometric data collected on samples from April to October of 2019 show nutrients levels (min-max) as follow: N-NO_3 $3.8 \div 107$ ppb; N-NO_2 $5.6 \div 10$ ppb; N-NH_4 $+ 0.7 \div 12$ ppb; DIP $0.2 \div 1.9$ ppb; DOP $12 \div 47$ ppb and Si-SiO_2 $3.2 \div 27.5$ ppb. On the sea side nutrients levels are very low, with no statistically differences between the two sampling points close to Natura 2000 site of Marano's Lagoon and outfall in seawater (Fig. 1).

The conductive plastic material was prepared as a thin film of about 300 μm and the presence of octamolybdate was appreciated with SEM techniques. In Figure 2 is possible



Figure 1 - Map of the sampling area in Marano's Lagoon (Adriatic Sea, Italy).

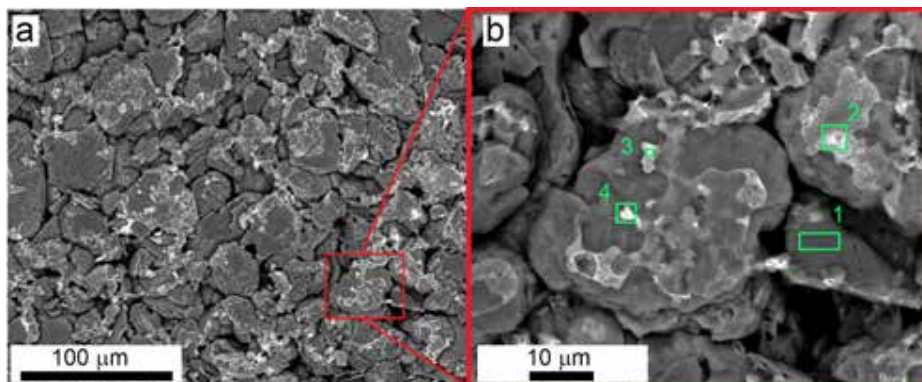

Figure 2 - (a) SEM picture showing the surface of the Mo-PE electrode. (b) High magnification SEM picture taken from the red square area marked in picture “a”, green squares show places where EDS analysis was done.

Table 1 - Results of EDS analysis performed at the Mo-PE electrode surface. The analysis was conducted in the sites marked with green squares in Figure 2b.

Spectrum label	Site 1	Site 2	Site 3	Site 4
C	100 %	79.77 %	90.97 %	93.44 %
O	0 %	13.4 %	5.12 %	2.64 %
Mo	0 %	5.33 %	3.01 %	2.43 %
Cl	0 %	1.51 %	0.90 %	1.49 %

to observe that the molybdate is dispersed over the electrode surface as a discontinuous film and after exploring several preparations, it was confirmed that no crystal was evident but just an amorphous dispersion. The energy dispersive X-ray analysis (EDS) confirmed that the film detected over the plastic surface contains molybdenum and oxygen, also by comparison with places without coverage where only carbon was detected. (Figure 2b and Table 1).

The Mo-PE film (Figure 3a) was cut to obtain the electrode to use as working electrode in a three electrode electrochemical cell. Cyclic voltammetry was conducted in solutions containing different concentrations of sulphuric acid (0.1, 1 and 5 M), NaCl 0.6 M and 100 ppb of phosphate. As can be seen in Figure 3b, the concentration of sulphuric acid is important since the reactivity of octamolybdate towards phosphate increase with the concentration of acid. When sulphuric acid concentration of 5 M was employed, three oxidation peaks and two reduction peaks were observed. However, just one oxidation peak appeared for concentrations of sulphuric acid of 1 M and no peaks were appreciated for concentrations of 0.1 M [8, 9]. Later, the effect of other acids as HCl was evaluated but in contrast with sulphuric acid, at higher concentrations (5 M) no defined peaks were detected (Figure 3c) [9]. Cyclic voltammetry experiments at different scan rates were performed (Figure 3d) to study the mechanism behind the electrochemical reaction taking place at the surface of the electrode. The curves obtained in solutions containing sulphuric acid 5 M, NaCl 0.6 M and phosphate 100 ppb show that there is not a direct relationship between peak signal and the

scan rate which suggest that the electrochemical reaction is independent of the diffusion of any component of the solution employed such as protons or phosphate, among others.

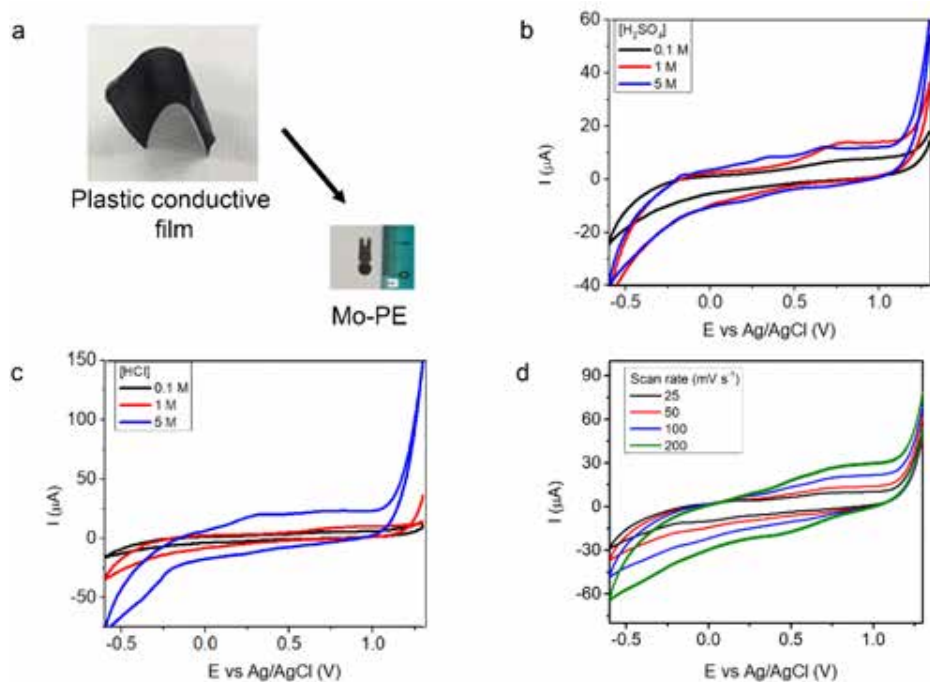

Figure 3 - Electrochemical characterization of Mo-PE electrodes. (a) Digital picture of the plastic conductive film used to prepare the Mo-PE electrode. (b) Cyclic voltammograms (50 mV/s) conducted in solutions containing H_2SO_4 0.1 M (black lines), 1 M (red lines) or 5 M (blue lines). (c) Cyclic voltammograms (50 mV/s) conducted in solutions containing HCl 0.1 M (black lines), 1 M (red lines) or 5 M (blue lines). (d) Cyclic voltammograms conducted in solutions containing H_2SO_4 5M at (black lines) 25 mV s^{-1} , (red lines) 50 mV s^{-1} , (blue lines) 100 mV s^{-1} and (green lines) 200 mV s^{-1} . All solutions employed contain NaCl 0.6 M (35 g/L) and 100 ppb of H_2PO_4^- .

To explore the sensitivity of the electrode towards phosphate, we decided to employ sulphuric acid 5 M and prepare solutions with different amounts of phosphate. As can be seen in the Figure 4a, when the orthophosphate concentration increase, reduction and oxidation peaks increase too. In particular, we obtained a good response for the reduction peaks obtained at around 0 V. In the Figure 4b the results of the analysis of this peak for three electrodes in the range of phosphate concentration studied, are reported. The lineal range obtained for the reduction peak at 0V is 0.1-1 ppb (Peak current = $4.82 [\text{H}_2\text{PO}_4^-] + 9.59$, $R^2= 0.980$) and the limit of detection (LOD) calculated (3σ) is 0.16 ppb.

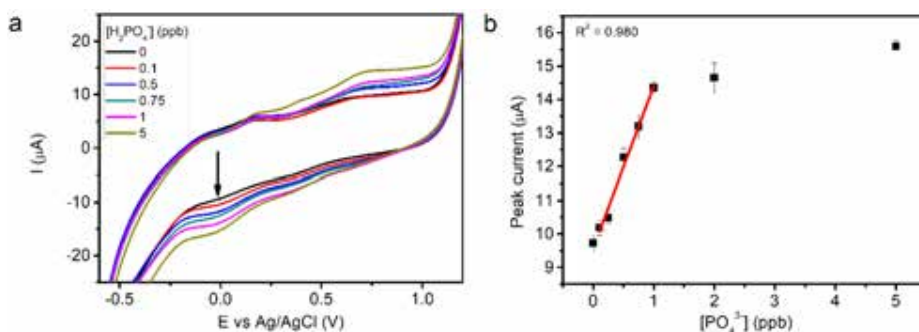

Figure 4 - (a) Cyclic voltammetry performed with different concentrations of phosphate (b) Analytical curve showing the detection range and the lineal range of detection.

Discussion

The nutrient analysis performed between April and October of 2019 show that the Northern Adriatic behave as an oligotrophic system. Lazzari et al. (2016) detected orthophosphate concentrations in northern Adriatic below 2 ppb which is close to those values obtained at the Mediterranean Sea [10]. The interesting fact is that the amount of nitrate is very high in comparison with Mediterranean Sea, which means that a possible eutrophication process can happen if the orthophosphate concentration increase since this last one is the most important limiting nutrient for this oligotrophic system. Among all the nutrients, inorganic phosphate levels are very low (0.2-1.9 ppb). The molybdenum-blue method is the gold standard method for in field detection but for oligotrophic systems some problems arises such as low sensitivity, low kinetic of complex formation and interference from sample turbidity. In this sense, there is an important need to develop new methods for in field detection comprising high sensitivity, fast response and low cost.

The proposed technology developed in this study is based on an electrochemical detection system employing the molybdenum chemistry. For these, a plastic electrode containing a non-aqueous soluble molybdenum salt (octamolybdate) [11] was constructed and tested with simulated oligotrophic seawater samples. After the electrode was prepared, the presence of octamolybdate was identified as a discontinuous film covering the surface of the electrode (Figure 2). Since the main hypothesis behind this study is that the octamolybdate at the surface of the electrode can react with soluble phosphate in the presence of protons to form phosphomolybdate at the interface electrode-water, we performed electrochemical analysis to analyze the effect of the acid. The results obtained suggest that the sulphuric acid is better than chlorhydric. Apparently, the reaction is favorable with sulphuric acid concentrations of 5 M, evidenced in the cyclic voltammogram by the presence of oxidation and reduction peaks (Figure 3b). The voltammogram shape suggest that the reaction produce the phosphomolybdate complex and the formation is accomplished in less than 5 min. In addition, the reaction happens at the surface of the electrode and is not enhanced by the diffusion of any solution component as can be seen in the Figure 3d.

The electrochemical reduction peak signal obtained at 0 V increases when phosphate is added to the sample at ppb levels. These results were confirmed through cyclic

voltammetry showing the possibility to use this technology to detect and quantify DIP in seawater at short incubation times (less than 5 min) with high sensitivity. The LOD obtained is low enough to detect directly the phosphate present in Northern Adriatic surface samples, or similar oligotrophic systems.

Conclusion

A new electrochemical method for phosphate detection was developed. The measurements were done in seawater simulated samples taking into account the phosphate levels detected in the Northern Adriatic surface samples. The method developed is fast and sensitive. The low cost fabrication of the electrodes as well the portability of the technology opens the possibility to use this method to monitor the phosphate levels in oligotrophic seawater samples. However, interferences studies and real seawater sample analysis need to be studied in detail to ensure a practical use of the electrode.

Acknowledgments

This research is supported by INTERREG V A 2014-2020 Italy–Croatia CBC Programme- AdSWiM Project (ID 10046144).

References

- [1] Cushman-Roisin B., Gacic M., Poulain P. M., Artegiani, A. (2013) – *Physical oceanography of the Adriatic Sea: past, present and future*, Springer Science & Business Media.
- [2] Water Frameworks Directive 2000/60/CE – *Marine Strategy Framework Directive 2008/56/EC*, Urban waste Water Directive 91/271/EEC. 2018, European Environment Agency: Nutrients in freshwater in Europe.
- [3] Strategic Environmental Assessment Adriatic, Ionian Operational Programme 2014–2020.
- [4] Zavatarelli M., Raicich F., Bregant D., Russo, A., Artegiani A. (1998) – *Climatological biogeochemical characteristics of the Adriatic Sea*. *Journal of Marine Systems*, 18(1-3), 227-263.
- [5] Bobacka J., Ivaska A., Lewenstam A. (2008) – *Potentiometric ion sensors*, *Chem. Rev.* 108, 329–351.
- [6] Talarico D., Arduini F., Amine A., Moscone D., Palleschi G. (2015) – *Screen-printed electrode modified with carbon black nanoparticles for phosphate detection by measuring the electroactive phosphomolybdate complex*, *Talanta* 141, 267–272.
- [7] Marsilia M., Susmel S. (2018) – *Free-standing Plastic electrodes: Formulation, electrochemical characterization and application to dopamine detection*, *Sens. Actuator B Chem.* 255, 1087–1096.

- [8] Nagul E.A., McKelvie I.D., Worsfold P., Kolev S.D. (2015) - *The molybdenum blue reaction for the determination of orthophosphate revisited: Opening the black box*, Anal. Chim. Acta, 890, 60-82.
- [9] Pennisi P., (1995) *A Study of Molybdenum Redox Couples*, Thesis dissertation, University of New South Wales
- [10] Lazzari, P., Solidoro, C., Salon, S., Bolzon, G. (2016) – *Spatial variability of phosphate and nitrate in the Mediterranean Sea: A modeling approach*. Deep Sea Research Part I: Oceanographic Research Papers 108, 39 – 52.
- [11] Klemperer W. G. (1990) In *Inorganic Syntheses*; Ginsberg, A. P., Ed.: John Wiley & Sons, Inc.: New York (27), 74 – 85.

MAPPING OF THE RISK OF COASTAL EROSION FOR TWO CASE STUDIES: PIANOSA ISLAND (TUSCANY) AND PISCINAS (SARDINIA)

Nicola Ghirardi¹, Mariano Bresciani¹, Giulia Luciani^{1,2}, Gianfranco Fornaro¹, Virginia Zamparelli¹, Francesca De Santi¹, Giacomo De Carolis¹, Claudia Giardino¹

¹CNR – Institute for Electromagnetic Sensing of the Environment, (Italy),

e-mail: ghirardi.n@irea.cnr.it; bresciani.m@irea.cnr.it; luciani.g@irea.cnr.it; fornaro.g@irea.cnr.it; zamparelli.v@irea.cnr.it; desanti.f@irea.cnr.it; decarolis.g@irea.cnr.it; giardino.c@irea.cnr.it.

² Department of Civil and Environmental Engineering, Politecnico di Milano, Milan (Italy),

e-mail: giulia.luciani@polimi.it.

Abstract – This study focuses on the use of satellite remote sensing to map coastal erosion vulnerability in two Italian sites: Pianosa Island (Tuscany) and Piscinas (Sardinia). For both areas we focused on the land/water transitional ecosystem, with the aim of identifying potential coastal erosion phenomena and to demonstrate the role of benthic habitats in preserving the value of coastal environments. The method made use of ancillary and multi-spectral satellite data from 2016 to 2018. For this study, the first 7 bands of the VIS–NIR region of Sentinel-2 were used, all reprocessed at the spatial resolution of 10 m. The TOA (Top of Atmosphere) radiance products were atmospherically corrected and processed using the Sen2Coral add-on-tool and the BOMBER code (Bio-Optical Model-Based tool for Estimating water quality and bottom properties from Remote sensing images). Maps of marine substrates and bathymetry were obtained and revealed their influence on the coastal dynamics. Then, in case of Piscinas, SAR images (COSMO SkyMed and Sentinel-1B) were added to the analyses. COSMO-SkyMed allowed us to identify the coastline and to obtain qualitative indicators about the absence/presence of changes in coastal dune system, the most relevant terrestrial element of the site. Sentinel-1B supported, by adopting an inversion process scheme, the analysis of the wave state impacting the coast. By merging the satellite products, the coastal erosion vulnerability maps have been generated based on substrate type in shallow waters and sand volume variation on land: rocky bottoms and stable meadows of phanerogams seemed preserving the coast, while the substrate characterized by a loss of phanerogams and a decrease in sand volumes might be considered more vulnerable. The results confirm that the coast of Pianosa is not suffering from coastal erosion, while the vulnerability maps of Piscinas seem to be closely linked to episodic events so that the Piscinas dune system might be considered safe from coastal erosion processes.

Introduction

Coastal processes are the result of forces acting on coastal areas and leading to the modification of these environments. Both natural and anthropogenic activities can lead to the degradation of these environments and consequently to other hazards such as: shoreline changes, sea-level rise, sea water intrusion, coastal erosion and floods [8]. Italy comprises ~8000 km of coastline of which approximately 25 % consists of low-lying plains, some of

which are subsiding with a potential for flooding. Coastline mapping and change detection are essential for safe navigation, resource management, environmental protection, and sustainable coastal development and planning [2]. In this context, satellite remote sensing has been used for about 50 years to obtain environmental information to support effective management for such landscape. The use of remote sensing techniques has many advantages including the ability to perform repeated captures on the same site and to instantly display large areas, overcoming many limitations imposed by in-situ sampling techniques. Recently, the Italian Space Agency funded the CosteLAB project (Contract Number 2017-I-8.0). The primary goal of the project is the creation of a virtual laboratory to analyse, develop and test applications and products for monitoring and managing coastal risk. The most common methods to estimate vulnerability and coastal erosion risk can be based on different indicators and model dynamics [10]. The added value related to the proposed research activity is represented by the mapping of different substrates (e.g. sand, rock, phanerogams) in correlation with bathymetry that influenced the dynamics of coastal erosion. As well as the use of radar images characterized by high frequency and spatial resolution, which can represent a turning point in mapping and monitoring of coastal areas [9]. Two case studies are developed to demonstrate the role of benthic habitats in preserving the value of coastal environments and in particular to mitigate the coastal erosion. The first is focused on Pianosa island starting from optical satellite data, while the second case study is focused on Piscinas and involves the use of both optical and radar imagery.

Materials and Methods

In this work two Italian study areas were analysed: Pianosa Island (Tuscany) and the coastal dune system of Piscinas (Sardinia) (Fig 1). Pianosa Island is the fifth, by extension, of the seven islands of the Tuscan Archipelago National Park with a total area of 10.2 km² and a coastal perimeter of approximately 20 km. The island is almost completely flat, with some small undulations. The highest elevation is 29 m above sea level (a.s.l.), while the average is about 18 m a.s.l. while, the coastal dune system of Piscinas is an area of about 1.5 km² located in the South of the Oristano Gulf in the Sardinia Island, near Arbus. It has one of the highest dune systems in Europe (for this reason it is part of the UNESCO World Heritage) and therefore has been selected for conducting the experiments about the use of satellite remote sensing for beach and dunes variation. The coastline extends for about 7 km and the maximum height is about 100 m. The surface is continuously remodelled by strong winds blowing from the West regularly over the whole year. A peculiarity of this area, clearly visible in each optical satellite image analysed in this study, is the presence of semi-circular depressed areas along the entire sandy coast at a variable distance (200÷500 m) from the coastline.

The remote sensing data used to develop this research theme were basically acquired by the Multispectral Imager (MSI) on-board of Sentinel-2A (S2). For the case of Pianosa, the selected images were acquired on 18/07/2016, 04/05/2017, 11/05/2017, 03/06/2017, 13/02/2018, 19/04/2018, 18/07/2018. While for Piscinas on 29/10/2016, 15/11/2016, 28/12/2016, 18/03/2017, 04/05/2017, 28/12/2018. For this second site, SAR images (COSMO SkyMed and Sentinel-1B) were added to the analyses. All these images were chosen because cloud-free, without sun-glint and other radiometric noise. Before processing the optical images, a comparison between Level 1 (L1) and Level 2 (L2) products was performed

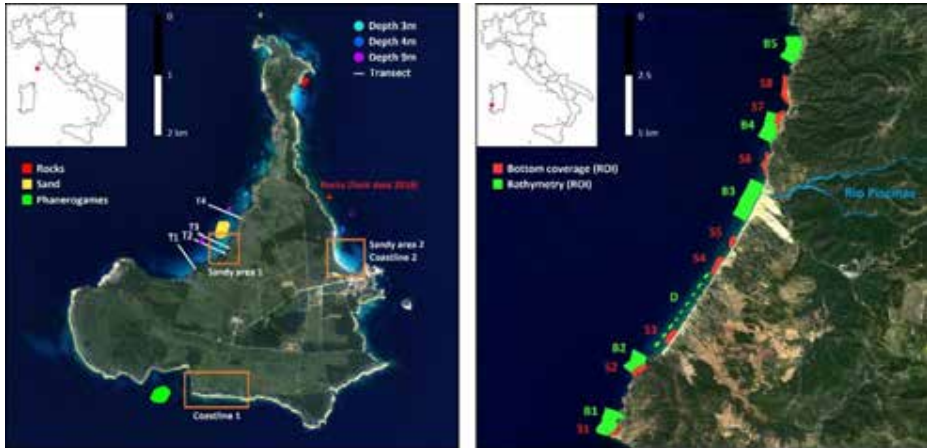

Figure 1 - Case study areas from Sentinel-2 images of 03/06/2017 (Pianosa) and 18/03/2017 (Piscinas). On the left the island of Pianosa: the two sandy areas and the coast segments analysed are squared in orange; bathymetric transects are represented as white lines (T1-T4) and the other coloured areas represent the regions selected as ground truths for validation of bathymetry and substrates. On the right the Piscinas coastal dune system: in red the regions of interest (S1-S8) used for the analysis of the bottom coverage classes; in green the regions of interest (B1-B5 + D) used for the bathymetric analysis; in light blue the Rio Piscinas torrent.

(Copernicus Open Access: <https://scihub.copernicus.eu/dhus>). L2 images containing bottom-of-atmosphere (BOA) reflectance as computed by Sen2Cor. Since this tool is not optimised for retrieving water reflectance above water, a comparison with the L1 images corrected atmospherically using the 6SV code (Second Simulation of the Satellite Signal in the Solar Spectrum code-vector version) [12] was performed. The spectra obtained with the procedures were in agreement and showed an aware deviation of 0.01 %. The 6SV output was chosen as reference due to its good performances in retrieving water leaving reflectance in inland and coastal waters [5,1]. To run 6SV, all bands of L1 images were reprocessed at the spatial resolution of 10 m through SNAP S2-toolbox, with nearest neighbour method. TOA radiance products, obtained using the SNAP tool ReflectanceToRadianceOp, were then atmospherically corrected with 6SV code. Finally, the 6SV output were converted into Remote Sensing Reflectances (Rrs) above water dividing the bands by π . The Rrs products were then processed using the Sen2Coral add-on-tool (Pianosa) and the non-linear optimization algorithm called BOMBER (Piscinas) in order to obtain maps of three different substrates (sand, rocks and phanerogams) and bathymetry. The described tools were applied to S2 images acquired between 2016 and 2018, a temporal range in which we do expect to observe recent possible erosion processes. The Sen2Coral tool is developed according to the state-of-the-art of spectra inversion of semi-analytical (SA) bio-optical modelling. This method relies on some form of spectrum matching of modelled reflectance spectrum using a set of bathymetry, bottom classification, and water column IOPs values, optimized to match the image Rrs (λ) spectra. Materials used for this site also include ancillary data such as: a bathymetric map and a georeferenced coastline of 2014 (ISPRA's website); a nautical chart

published by *Istituto Idrografico della Marina*; a RapidEye image of summer 2017 and Google Earth imagery. BOMBER [4] is instead a non-linear optimization algorithm used, like Sen2Coral, for the classification of the bathymetry and of the substrate coverage. The Rrs images were used as input and the bio-optical modelling system was applied in shallow water mode and, for each image, was applied to a mask that includes water up to 1000 m from the coastline (maximum depth between 10 m and 12 m). The bathymetric outputs obtained with the BOMBER were compared with a bathymetric map available at "<https://webapp.navionics.com>" website.

In addition, for the site of Piscinas, three SAR images from COSMO SkyMed mission (synchronous or as much as possible close to the optical images acquisition; 27/12/2016, 17/03/2017 and 04/05/2017) were also analysed to better identify the coastline (Fig 2). The coastline was identified using two approaches: one based only on optical images (Rrs images) and one merging bands of Rrs images (band2-490 nm and band6-740 nm) with SAR COSMO SkyMed. To obtain the Rrs+SAR outputs, the available SAR images were first georeferenced. Then a "write function memory" was performed to obtain a product characterized by both Rrs and SAR bands. This method consists of inserting individual bands of remotely sensed data into specific bands of image processing (red, green and blue) to highlight change [11]. This process is mainly used to highlight temporal changes between images of the same sensor [7], while in this work it has been used to highlight changes between different sensors (Sentinel-2 and COSMO SkyMed). As a result, an RGB output was displayed to identify the coastline: Red=band2 (Sentinel-2 Rrs), Green=band6 (Sentinel-2 Rrs) and Blue=SAR (COSMO SkyMed). No synchronous SAR images were available for the Pianosa site, so the coastline was identified through the Sentinel-2 NIR bands and by comparison with the ISPRA map. In particular, the temporal evolution of the Pianosa coastline in 2016-2018 was analysed in two segments: the sandy beach of Cala della Giovanna and a rocky segment in the south of the island (Fig 2).

The research theme concerning the beach and dunes volume changes has been integrated by COSMO-SkyMed SAR data acquired over repeated orbits. To this aim, the research activity has been performed in the site of Piscinas. The analysis is concentrated on the use of the multitemporal amplitude and phase response, which allows characterizing the coherence properties as well as the presence or absence of deformation. A stack of 62 COSMO-SkyMed images acquired in 3 years from 16/06/2015 to 24/06/2018 has been analysed. Data have been processed with a two-step interferometric processing method implemented at small (low) and large (high) scale (resolution) [3]. The deformation analysis provides information about the areas that shows constant characteristics over the time and that are therefore less affected by the erosion factors, particularly the action of the wind.

For the Piscinas site, the wave state impacting on the coast was also analysed. Sentinel-1B SAR image gathered on 06/05/2019 at 05:28 UTC and showing a sharp wave-modulated backscatter was analysed. The backscatter analysis performed with CMOD algorithm returned a wind speed of 16 m/s impinging with direction toward the coast (330° N), a result comparable with ERA5 reanalysis data provided by ECMWF. The retrieved wind field was then used to estimate the sea surface wave spectrum from a SAR image's subregion of 512x512 pixels centred at 39.5° N, 8.25° E. The Hasselmann's procedure to extract the sea surface wave spectrum from the measured SAR spectrum [6] was finally applied. A complex wave spectrum composed by a wind sea component with dominant wave with 140 m wavelength coming from 311° N and a swell of 135 m wavelength coming from 341° N with

total wave height of 4.82 m was obtained. This SAR retrieved wave state was comparable with the respective prediction by the wave model WAM provided by ECMWF.

The bottom depths of Pianosa obtained as output by Sen2Coral were tide corrected and compared for validation with bathymetric data obtained from the nautical chart. Data were extracted from the output maps through linear transects (T1-T4) (Fig 1). Depth values were extracted and analysed from the output also in small areas around points of known bathymetry (Fig 1). Maps of reflectance at 550 nm produced by Sen2Coral were classified on the basis of substrate type expected in each reflectance range. The substrate maps obtained were analysed with confusion matrices built on the ground truth areas (based on visual interpretation), to evaluate the accuracy of the substrate classification. Based on Sen2Coral output maps of bathymetry and substrates, two sandy areas (Fig 1) were selected to evaluate the variation of water volumes contained in the bays. This methodology could be used to define the erosion process, as the increase of water volumes indicates the progression of the coastline toward the land. For the classification of the Piscinas bottom coverage and bathymetry, a series of ROI's were analysed (Fig 1). In detail, 8 ROI's (S1-S8) were evaluated for the bottom coverage maps and 5 ROI's (B1-B5, in addition to the semi-circular depressed zones "D.") for the bathymetric maps (Fig 1). For the first 8 ROI's, the percentage of coverage of each class (sand, rocks and phanerogams) was assessed. The 5 ROI's of the bathymetric maps were divided into 4 subclasses based on the distance from the coast (10÷200 m, 201÷400 m, 401÷600 m and 601÷800 m). Moreover, the variation of the average depth and the water volume were assessed, also considering the tidal phenomena. Besides, the first two images of 2016 (29/10 and 15/11) were used to evaluate the effects of a strong wind event that occurred in the time interval of acquisition of the satellite.

Results

With respect to the downloaded images, three of them were considered optimal for the analysis of the benthic habitats of Pianosa Island (18/07/2016, 03/06/2017 and 19/04/2018). The analysis of the temporal evolution of the coastline obtained from NIR bands, shows that the position of rocky segments doesn't change in time; also, shows that no significant modifications to the shoreline occurred for the two sandy area analysed in the period 2016-2018 (Fig 2). For the Piscinas site it was possible to make a comparison between the coastline produced by optical images and that produced by SAR+Rrs (Fig 2). This comparison shows differences in the range from a few meters up to 20 m between the two coastlines. In fact, the interpretation of optical images was complex, especially in the so-called "mixed" pixels, located at the water/sand interface, while SAR+Rrs images allow to better distinguish between these two surfaces. As a result, the coastline derived from SAR+Rrs images was more accurate. For this reason, the coastline obtained in three different date (27/12/2016, 17/03/2017, 04/05/2017) from SAR+Rrs images was compared (Fig 2) showing that along the sandy coast the coastline had a greater variability (up to 20 m) than near the rocky shores (up to 5 m).

The reflectance maps of Pianosa at 550 nm produced by Sen2Coral were classified based on reflectance range expected for each substrate type, so that values lower than 0.08 were assigned to phanerogams, values higher than 0.2 to sand and those in between to rocky substrates. Most of rocks are detected in shallow water along the coastline, sandy substrates can reach bottom depths at around 5 m and macrophytes are detected in deeper regions. The

output of Sen2Coral was analysed with confusion matrix. The results show good overall accuracy when considering regions corresponding to the three ‘pure’ end-members, sand, macrophytes and rocks. The accuracy decreased when regions of mixed substrates were included in the analysis. This could be due to the procedure used to select ground truth areas, which is not based on field data but on visual interpretation. Comparison of bottom depths obtained with Sen2Coral with data derived from the georeferenced nautical chart shows good agreement between the data and the available ground truths (based on a punctual information from field data acquired by Reparto Ambientale Marino, Livorno). Analysis of the transects showed that no significant modifications of bathymetry occurred in the period 2016-2018. Moreover, comparing the water volumes of the two sandy areas, it emerged that only small volumetric variations occurred during the period considered (about 6÷7 % from 2016 to 2018).

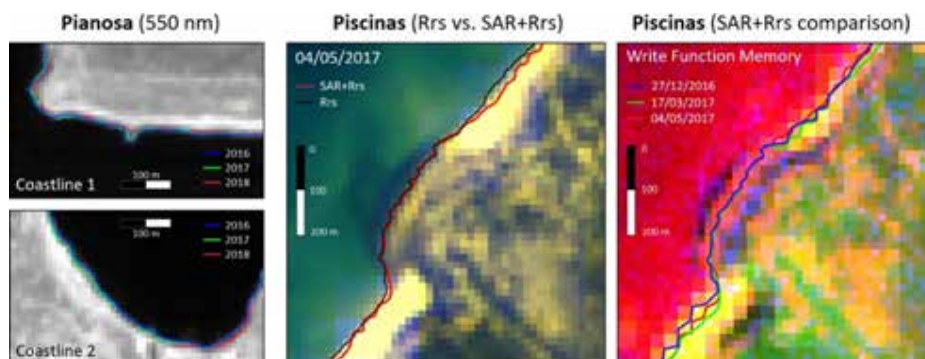

Figure 2 - On the left, the temporal evolution of the coastline (18/07/2016, 03/06/2017, 19/04/2018) obtained from NIR bands in the two segments analysed for Pianosa. In the middle, the comparison between the coastline obtained by Rrs image (black line) and the coastline obtained by SAR+Rrs images (red line), along a fraction of the Piscinas coast on 04/05/2017. On the right, the temporal evolution of the coastline derived from SAR+Rrs images acquired on 27/12/2016 (blue line), 17/03/2017 (green line) and 04/05/2017 (red line).

In each bottom cover maps of Piscinas, the main class is the sand one, followed by the remaining two classes (phanerogams and rocks) which were concentrated near the coast (up to 150÷200 m from the coastline). The phanerogams class was concentrated along the rocky portions of the study area, while along the sandy shores it is easier to find mixed pixels (sand/rock). The analysis of the 8 ROI's related to the bottom cover classes allowed to suggest that Piscinas was a changing system over time. The two images interspersed with the windy event (29/10/2016 and 15/11/2016) showed in all ROI's, with the exception of sandy areas S3 and S4, a decrease in phanerogams class (from 2.1 % to 15.7 %). Moreover, the image of 28/12/2018 was characterized by the lowest percentage of phanerogams' coverage for all ROI's considered. This peculiar picture needs in situ data, to better understand the vegetation dynamics. From the bio-optical model, bathymetric maps were also obtained. Within the analysed area (0÷1000 m from the coastline), the maximum water depth never exceeds 12 m and the slopes are never steep, especially along the dune system. The semi-circular depressed

areas (D) are clearly visible in each image, in particular in the south-western part of the dune system. The bathymetry varies considerably along the whole area after the windy event analysed, especially in the sandy area in front of the Rio Piscinas estuary. In particular, the deepest bathymetric class (>8 m) decreased along the coast (from 1170.26 ha to 505.97 ha; -57 %), while the two intermediate classes (from 4 to 8 m deep) widen considerably (from 522.44 ha to 1252.12 ha, +59 %). The bathymetric level variation observed in the areas close to the coast (the first two classes, up to 4 m deep) was not significant. The bathymetric map of 28/12/2018 showed a clear increase in the depth of the semi-circular depressed areas. The results of the analysis of the 6 bathymetry ROI's (B1-B5 + D) showed that the total volume of water (considering the tidal events), vary over time. Focusing on depressed areas, during the observation period, their total area varies from a minimum of 62.5 ha (29/10/2016) to a maximum of 137.7 ha (28/12/2018). Instead, after the windy event, a small variation in the depressed area extension was recorded (62.5 ha on 29/10/2016, and 65.8 ha on 15/11/2016).

The results obtained from the analysis of the wave state impacting on the coast of Piscinas, show that SAR peak has been well captured from the SAR inversion both in terms of wavenumber location and amplitude. The SAR inverted sea surface parameters reported a wave height of 4.82 m, that is compatible with the 4.77 m predicted by WAM. Even the SAR retrieved wave direction (341° N) agrees to WAM predicted one (321° N). Discrepancies with WAM prediction are within the expected sampling variability of the SAR estimate.

Based on bottom type and sand volume variation we have created maps of vulnerability for the two sites under review (Fig 3). For Piscinas it was possible to create a short-term (windy event) and a long-term (comparison between 2016 and 2018) vulnerability map. We have assumed that the rocky bottoms and stable meadows preserve the coast, while substrates characterized by a loss of phanerogams and a decrease in sand volumes might be considered vulnerable. The results confirm that the Pianosa coastal zone doesn't have a problem

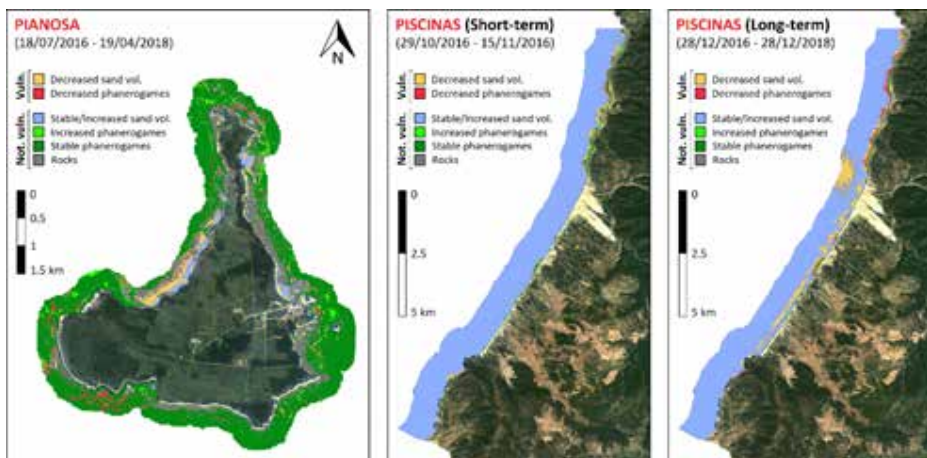

Figure 3 - Vulnerability maps of coastal zones obtained from the classification of substrates and bathymetric analysis. On the left, the vulnerability map of Pianosa (2016-2018); in the middle, the short-term vulnerability map of Piscinas (windy event: 29/10/2016 - 15/11/2016); on the right, the long-term vulnerability map of Piscinas (2016-2018).

with the coastal erosion. For Piscinas the least vulnerable map is the short-term, while the most vulnerable map is the long-term, which is characterized by a marked decrease in sand volume (especially in front of the estuary) and a decrease in phanerogams.

Finally, the coherence map obtained through the analysis of COSMO-SkyMed images shows the presence of an area, developing along the torrent bed of Rio Piscinas, characterized by low level of coherence. More generally, the measurements seem to indicate about an overall stability of the coastal area, with higher coherence in the southern part respect to the northern part, and higher coherence in coastal areas than in the inner regions.

Discussion

The analysis of the coastline obtained from NIR bands, shows how the position of rocky segments doesn't change in time, thus confirming the hypothesis that this bands can be used to define the land contour. The satellite images of Pianosa showed that no significant modifications to the shoreline occurred in the period 2016-2018. This confirms the hypothesis that phanerogams meadows along the coast help containing the erosion process. However, the interpretation of optical images remains complex, especially in the so-called "mixed" pixels, located at the water/sand interface. The use of SAR+Rrs images for Piscinas, instead, allow to better distinguish between these two surfaces. The results obtained from this analysis on a short temporal window (from winter 2016 to spring 2017), highlight a certain degree of variation in the sandy portions of the coastline. These changes may be due to the tide level variation, the wave motion and the sensors spatial resolution. Consequently, the use of SAR+Rrs images may be useful to study the temporal evolution of the coastline. The analysis of sand volumes variations in the two sandy areas examined for the island of Pianosa, shows overall only minor variations in the period considered, resulting in slight increments of sandy volumes, which confirms a stable situation that is not conditioned by erosion processes. Bathymetry, on the other hand, varies considerably along the entire Piscinas dune system. Consequently, Piscinas can be identified as a not stable at bathymetric level, probably due to the synergistic effect of wind and sea currents on an area characterized principally by sand substrate. In particular, between 29/10/2016 and 15/11/2016 (windy event), the deepest bathymetric class (>8 m) decreased along the coast (reduction of 57 %), while the two intermediate classes (from 4 m to 8 m deep) widen considerably (increase of 59 %). This variation was probably due to the sand mobilization wind induced that once deposited decreased the overall volume of water. This absence of large bathymetric variations close to the coast, during wind events support the speculation that these changes seem to be relevant only far from the coastline. Considering also the distance from the coast, near the shoreline the average depth and total water volume were similar in the two images spaced out by the windy event, while moving away from the coast (from 400 m onwards), these two values were always lower in the post-wind image compared to the pre-wind one. Again, these results reinforce the evidence that the wind event affects mainly areas far from the coast. Finally, based on the bottom type and sand volume variation it was possible to create maps of vulnerability of coastal zone of the two study areas. For Piscinas, a short-term (wind event) and a long-term map has been created. The results show that the least vulnerable map is the short-term, i.e. the one relating to the windy event. The wind has led to the deposition of a large amount of sand, especially away from the coastline, and has not led to a marked

decrease in the phanerogams. On the other hand, the most vulnerable map is the long-term, which is characterized by a marked decrease in sand volume and a decrease in phanerogams, especially in the rocky areas to the northeast. However, these results are influenced by the significant extension of the semicircular depressed zones in 2018.

Conclusion

In conclusion, the use of multi-source remote sensing satellite data allowed us to contribute to the assessment of the phenomenon of coastal erosion phenomenon, offering a new perspective and allowing us to overcome some limitations associated with field surveys. In particular, the spatial resolutions of both optical and SAR images, resulted appropriate for the target areas, while the dedicated processing and the use of physically based algorithms provided reliable results, although further activity seems necessary to validate the satellite-inferred maps. The results confirm that the coast of Pianosa has no problems of coastal erosion, while the vulnerability maps of Piscinas seem to be closely linked to episodic events (e.g. strong wind or extension of depressed areas), with minor-to-none impacts on the Piscinas dune system.

Acknowledgements

This study was supported by the Italian Space Agency with the project CosteLab (grant nr. 201721199). We are grateful to Deodato Tapete and Ettore Lopinto from the Italian Space Agency for encouraging the synergic use of optical and radar images and to Monica Palandri from e-geos, for project management and valuable discussions on this study.

SAR results generated by processing CSK® Products, © of the Italian Space Agency (ASI), delivered under a license to use by ASI.

References

- [1] Bresciani M., Cazzaniga I., Austoni M., Sforzi T., Buzzi F., Morabito G., & Giardino C. (2018) - *Mapping phytoplankton blooms in deep subalpine lakes from Sentinel-2A and Landsat-8*, Hydrobiologia. 824 (1), 197 - 214.
- [2] Di K., Ma R., Wang J., Li R. (2004) - *Coastal mapping and change diction using high-resolution IKONOS satellite imagery*.
- [3] Fornaro, G., & Pauciuillo A. (2018) – “*Interferometric and Tomographic SAR.*” *Novel Radar Techniques and Applications*. 361 - 402.
- [4] Giardino C., Candiani G., Bresciani M., Lee Z., Gagliano S., & Pepe M. (2012) - *BOMBER: A tool for estimating water quality and bottom properties from remote sensing images*, Computers & Geosciences. 45, 313 - 318.
- [5] Giardino C., Bresciani M., Fava F., Matta E., Brando V.E., & Colombo R. (2015) - *Mapping submerged habitats and mangroves of Lampi Island Marine National Park (Myanmar) from in situ and satellite observations*, Remote Sensing. 8 (1), 2.

- [6] Hasselmann K., Hasselmann S. (1991) - *On the nonlinear mapping of an ocean wave spectrum into a synthetic aperture radar image spectrum and its inversion*, Journal of Geophysical Research: Oceans. 96 (C6), 10713 - 10729.
- [7] Jensen J.R., Cowen D.J., Althausen J.D., Narumalani S., & Weatherbee O. (1993) - *The detection and prediction of sea level changes on coastal wetlands using satellite imagery and a geographic information system*, Geocarto International. 8 (4), 87 - 98.
- [8] Mujabar P.S., & Chandrasekar N. (2013) - *Coastal erosion hazard and vulnerability assessment for southern coastal Tamil Nadu of India by using remote sensing and GIS*, Natural Hazards. 69 (3), 1295 - 1314.
- [9] Palazzo F., Latini D., Baiocchi V., Del Frate F., Giannone F., Dominici D., & Remondiere S. (2012) - *An application of COSMO-Sky Med to coastal erosion studies*, European Journal of Remote Sensing. 45 (1), 361 - 370.
- [10] Ramieri E., Hartley A., Barbanti A., Santos F.D., Gomes A., Hilden M., Laihonon P., Marinova N., & Santini M. (2011) - *Methods for assessing coastal vulnerability to climate change*, ETC CCA Technical Paper. 1 (2011), 1 - 93.
- [11] Sader S.A., & Winne J.C. (1992) - *RGB-NDVI colour composites for visualizing forest change dynamics*, International journal of remote sensing. 13 (16), 3055 - 3067.
- [12] Vermote E.F., Tanré D., Deuzé J.L., Herman M., Morcrette J.J., Kotchenova S.Y. (2006) - *Second Simulation of the Satellite Signal in the Solar Spectrum, 6s: An Overview*. 6S User Guide Version 3.

NEW COASTAL PROTECTION AND SEA ENERGY PRODUCTION

Pierfranco Ventura¹ Manlio Palmarocchi²

¹ Eng. Via Emilio Repossi 19 – 00158 Roma

phone +39 3356434580, e-mail: pierfranco.ventura@steseoetica.it

² Eng. former Responsible for Renewable Energy – ENI-Roma

Abstract - A new location for coastal protection is in the seabed transition zone, where offshore pulsing vertical wave energy is converted into inshore horizontal current energy. Artificial reefs, which consist of staggered barriers made up of turbines, create a soft defense of the coasts that mimic coral reefs, close to the calm belt, far from the storms. These barriers reduce the sea current speed below sea level with the consequent deposition of suspended sand for natural nourishment. The second advantage is that the vertical turbines are made up of a helix fixed to a floating spinning top so that it is in an indifferent equilibrium in the water, turned, therefore, by minimum currents. The supports on which the propellers are pivoted, are implanted in recycled material powder trusses for 3D printers. They are laid on the sea bed and are movable, in the same way as a naval wreck. Electric energy is produced even with a low number of revs, but this production is long lasting, and therefore with a higher number of hours of production per year than eolic and photovoltaic MW. The production, $5 \div 10$ GWh/km per year, is dependent on the exploitable marine energy (minimum 3 kW/m to max 10 kW/m) and the extension of the propellers and artificial reef distribution. The costs of these barriers are very advantageous compared to current coastal defenses, based on the costs of beach artificial nourishment and on the maintenance of breakwaters. This is because the production of electricity covers the cost of amortization, and in particular the high annual cost of maintenance. Moreover, as well as the favorable MW/€ comparison with eolic offshore energy production, there is also the question of beach recovery, which does not occur in the case of eolic production. Furthermore, the cost of the floating foundations and the submarine cable inshore is significantly lower than the offshore costs. The total submersion of the artificial inshore reef minimizes the environmental and landscape impact compared with the current systems. A further advantage of this new defense is that it prevents sea-level rise due to climate change by embanking the coast by means of natural nourishment and re-growth of the marine grasslands, thereby recovering hectares of beach, with subsequent economic benefits especially for tourism. In Italy, erosion affects over 1200 km of coastline, equal to 1/3 of the sandy beaches, which have been reduced by up to 25 m, or more than 2 ha/km, with great economic loss. The rise in the beach level and limitation of coastal erosion represents the principal economic benefit. The proposal is to substitute traditional nourishment and breakwaters with energized reef turbines so as to favor the marine ecosystem and the landscape, and to promote sea depollution, with systematic control of plastics. It highlights the importance of monitored experimental research, in real scale, to develop the economic and environmental benefits.

1 Introduction

The first proposed breakwater to protect the coasts (Ventura 1992) was based on finned cylinders anchored to ballast on the seabed, like Bristol cylinders, without the production of electric current.

The 1:4 scale models were tested at the INSEAN naval tank in Rome with encouraging results regarding the damping of the height of the waves as the test frequencies increased.

The new type of artificial barrier for the protection of the coasts was designed by Palmarocchi-Ventura (2018) and made known through STES: Scientists and Technologists for Development Ethics (www.steseoetica.it).

The main activity of this *cultural volunteering organization* is to document projects for the protection of the environment integrated on an ethical basis.

With regard to this objective, the new barriers make a valid contribution towards marine energy production and coastline-seabed protection.

In fact, the traditional protection based on rockfill breakwaters and nourishment is anti-ecological and anti-economic.

The new barrier was approved by the Munich Patent Office and is registered in the CNR SOLAR (Scientific Open-access Literature Archive and Repository) database as a technological innovation. The barriers are usable by Start Ups within the framework of the Green Economy and the 20/30 European Green Deal.

2 Description of the new defense

The idea starts from the observation that the energy of the wind produces enormous pulsing vertical waves on the sea, stationary regime (Boussinesq 1897), when the bathymetry is deep.

Approaching the coast, where the seabed is around 6÷7 m, the same waves (Fig. 1a) are converted into direct horizontal currents towards the shore (G. Ferro, 1970).

This occurs, according to the marine geomorphology (Mas-Pla, Zuppi, 2009), about 300 ÷ 500 meters on average from the shore, when the currents then proceed at lower depths, 3 ÷ 4 meters, they are converted into storm surges, which cause erosion.

After the offshore/inshore calm area there is the *inshore mature*, “*festina lente*”, *formation of horizontal currents*. In this particular zone a new artificial reef can be placed as a soft defense (fig. 1a), which *mimics the coral reef* (Fig. 5a), *whit location far from the sea storms* (fig. 1b).

In this regard it is very important the coastal monitoring and research to the storm impact along coastlines (Ciavola P. et al. 2011) in particular by inshore/offshore *currentmeters*, from compound float or “differentiated consumption wind-rose” chalks to triaxial acoustic (Fig. 2), and *telewattmeters*.

The traditional defenses of the coasts are based on rockfill breakwaters near the beaches (Fig. 3), which also induce upheavals on the seabed and erosion of the unprotected coast. The artificial nourishment of beaches with traditional rocky barriers is supplied via powerful pumps which extract fine sediment from the seabed offshore. However, this sediment, which is granulometrically unsuitable, is systematically removed by storms.

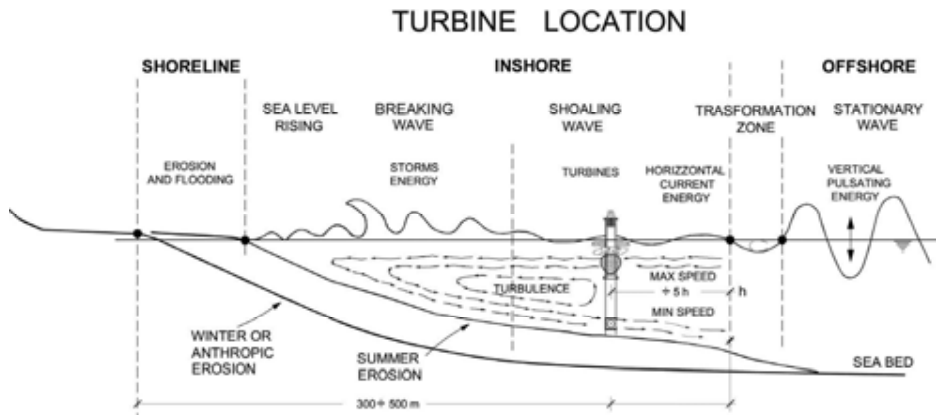

Figure 1a - Turbine barrier location, similar to that of coral reefs (fig. 7), is where the energy of the vertical pulsating waves (offshore) is converted into horizontal sea currents (inshore). This constitutes a *soft defense*, with electricity production. Excessive erosion resulting from anthropic causes is reduced by the particular positioning of the turbines, which simultaneously dampen the currents on the seabed. Conversely *rigid defenses* (rockfill, piers, etc.) during the sea storms increase breaking of the waves, especially at low depths.



Figure 1b - Offshore/inshore calm area during a strong storm surges in Tuscany.

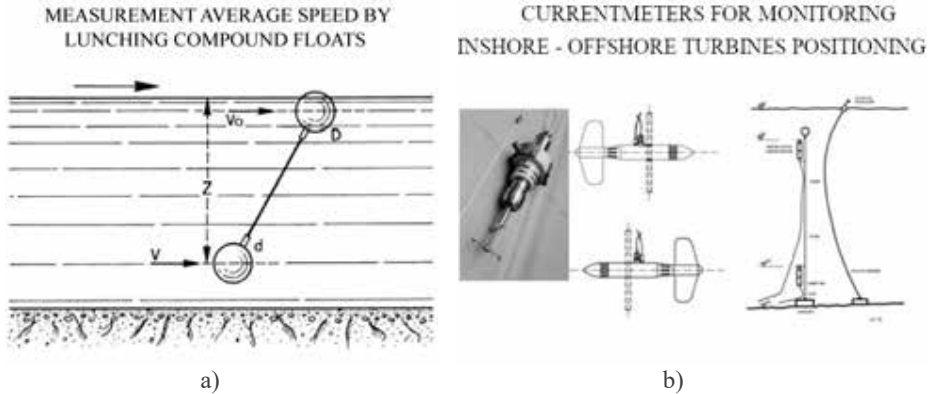

Figure 2 - Old (a) and modern (b) currentmeters for monitoring inshore/offshore marine currents, for turbine positioning and research of antierosion efficiency.

Both these types of defenses are inefficient and expensive. To help modify these traditional types of defenses, a new energized reef is proposed, which substitutes the natural damping of the *winter mobile sand shoal*.

The patented vertical axis turbines (Fig. 6a, b) consist of propellers fixed immediately below the sea level between two floats: the superior disc is for lamination of the currents and the inferior disc is a whirligig for spin stabilization.

Kinetic sea energy is more competitive than eolic. The turbine, with specific gravity equivalent to water, is in indifferent equilibrium in the water and turns at minimum levels of marine currents. The electric energy is produced even with a low number of laps and it is long lasting, with *higher hours of production* than eolic and photovoltaic.

The tubes on which the propellers are pivoted, are implanted in the sand like “sea razor clam” shells, and are produced by 3D printers using metal powder recycled scrap.

They are thus similar to (Fig. 5b) coral reefs with sand (Dini 2020), or fiber-reinforced ones which are already on the market for offshore structures.

The floating propeller block is also made of the same material by 3D printers, and it drives a low-frequency multipolar dynamo.

The turbine, nearly 20 kW, converts marine energy starting from $2 \div 3$ kW/m of the wave energy. Furthermore, the hours of electricity production are much higher than for wind, as the water pushes on the propellers much more than the air, and they are more efficient than photovoltaics, since the marine turbines can also work at night.

The tubes are vibro-infixed at a suitable depth in the seabed, similar to mooring dolphins (Ventura 2019), so as to constitute a *strong foundation* with a prefabricated tripod module, which is bonded at the base by means of a triangular mesh.

To keep the propeller disposition stable, these fixed pipes can also be replaced by foundations consisting of a continuous truss anchored on the seabed and with stresses adaptable to marine displacement.

This submerged foundation will have the same impact as that of a naval wreck, and increase diving tourism.

The truss on the seabed can also be transported for the defense of other coastal areas, after stabilization of the ecosystem. The life of the barriers also allows for regrowth of the posidonia, preventing the uprooting of the nurseries (Marsella 1986).

The arrangement of the turbines, which are staggered in the barriers, results in significant damping of the marine currents thereby reducing the speed and creating a “soft” defense of the coasts without negative side effects.

It should be noted that the marine energy to be damped by the turbines is caused by excessive, urbanization-induced erosion, which has destroyed the dunes and the Mediterranean maquis that protected the beaches from wind.

On the other hand, summer-winter erosion, especially that which replaces the movable sandbank on the seabed, is a powerful natural damper of marine energy which defends the coasts.

This natural defense by sand nourishment is enabled by the turbine reef, comb filtering effect, which serves above all to avoid excessive anthropic erosion (Fig. 1, 3 e 4).

The planimetric distribution of the turbines, which replaces the mobile sandbank, must be adapted to each shoreline (Ricci Lucchi 1992) based on the geomorphology of the seabed and maritime weather data of the fetch.

Both characterize the energy of the waves, which go from over 10 kW/m in Sardinia to less than 5 kW/m on the coasts of the Tirreno.

The new reef defense makes it possible to raise the level of the beach through natural nourishment, in order to guard against the rising sea level (3 mm/year) caused by climate change and significant melting of glaciers.

Areas of beach flooding, nearly 1 m/10 years (slope 3 cm/m), are embanked thanks to the proposed defense, especially where the sediment transport of rivers is low.

In Italy, erosion affects over 1200 km of coastline, equal to 1/3 of the sandy beaches, with reductions of up to 25 m, or more than 2 ha/km.



a)

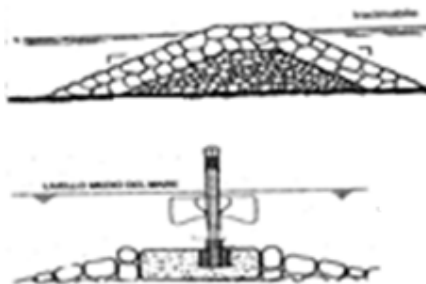

b)

Figure 3 - a) Increasing erosion and seabed desertification near rockfill breakwaters during storm surges; b) Increasing extension and cost of the rockfill breakwater with the increase in the depth of the sea. With the new turbine defence this cost is negligible as the only added requirement is a longer shaft. The turbines can also be used on existing submerged breakwaters, thus providing synergetic protection.

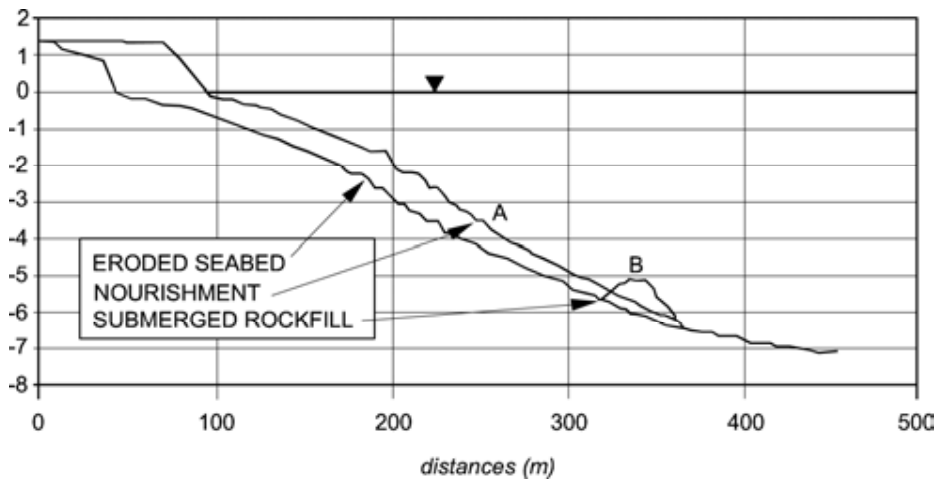

Figure 4 - Traditional beach artificial nourishment (A) and submerged rockfill barriers (B) only slow, but do not stop, excess erosion caused by the removal of the dunes and the Mediterranean maquis. The submerged top (B) must not reach sea level; otherwise the speed of the currents will increase. Similarly, during sea storms the emerging rockfill breakwaters, which are specifically situated in the breaking waves zone (Fig. 1a, b), exacerbate erosion of the seabed in unprotected beaches, both frontally and laterally (Fig. 3a).



a)



b)

Figure 5 - a) Coral reef in the offshore/inshore transition zone (Fig.1), imitated by using an energized barrier for the reconversion of traditional coastal protection (Fig. 3 e 4); b) Similarity to artificial coral reef produced by 3D printer (Dini).

The barriers provide further advantages regarding the rooting of sea grasslands, in particular of *posidonia*, which prevents erosion and promotes fish repopulation and sea depollution. It also prevents eutrophication, which is amplified by rockfills close to beaches.

In particular, the boulders of the rockfills could be transformed into gravel of a suitable artificial nourishment granulometry for integrating the turbine barrier defenses, with the restoration of the original littoral landscape.

FLOATING TURBINES

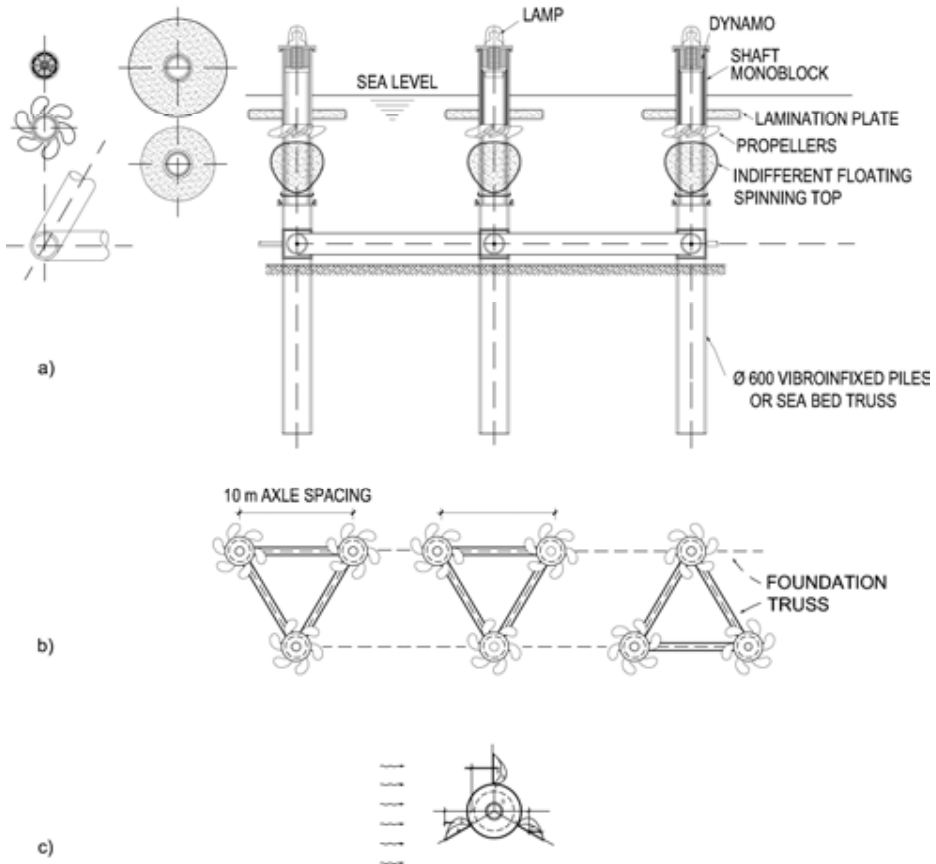

Figure 6 - a) Turbines with indifferent floating monoblocks (patent n° 0001411057; database CNR SOLAR code 9861TR2019) are pivoted on tubes. The pile-tubes are vibroinfixed in the sea bed, or founded on a reticular truss placed on the seabed, similar to a naval wreck; the whirligig is filled with sponge to prevent infiltrations from impacts; the propeller, whirligig and piles are printed in 3D using metal powder made from recycling machine scrap, or internal piles in fiber-reinforced.

b) Prefabricated tripod piles, similar to dolphins, adapted to marine geomorphology and meteo-maritime prevalent fetch; incremental current damping is achieved by reducing the axis of the comb and alternating the spin of the propellers;

c) Research of propeller efficiency: number, extension, external convex curvature, *cup type anemometer or pinwheel*, eccentric to internal concave curvature of the blades, to differentiate the thrust arms, also convex water-repellent curvature (similar to sharks).

The extraction of sand at sea or land is eliminated, thereby decreasing significant environmental damage.

The descaling of the turbines is facilitated by the simple extraction of the propeller block from the foundation tube. The cost of maintenance is covered by kWh production.

The turbine reef, with gaps for the passage of boats, places a limit on fishing and recreational navigation, and is positioned at the regulatory safety distances. It is possible to moor boats along the turbine reefs, thus freeing up the ports.

This new energy production could recharge accumulators, and boat owners in particular could buy turbines.

It is possible to insert a series of marine vacuum cleaners (*seabins*), whose function is to free the sea of finely shredded *plastic and other garbage*. Sensors for *chemical control* could also be incorporated, with safe water quality documented by “blue flags” displayed on beaches.

The turbines, which have the same equivalent mass as water, have a period of null oscillation that are not affected by resonance ($T \div 0 < T_{Tirr} \div 3$ s) and are therefore seismic resistant, so they would continue to work in the event of an earthquake. Moreover, submarine cables are significantly less susceptible to damage by bad weather than terrestrial ones.

The proximity of the coasts to the Apennines also allows for hydraulic *storage* of renewable energy by pumping water to a high altitude with “reverse” pump-turbines.

This would balance the uncertainty of renewable current production and help to mitigate the release of CO₂, and fuel particulates (HC, NOX, CO, PM).

3 Economic competitiveness of coastal protection by turbine barriers

Wind power production in Italy is set to reach 10 GW, with a further contribution made by the above-described marine energy production. This will help both the global-local green economy of the renewable energy and above all environment protection.

The investment for 1 km of coastline varies for a barrier of 100 compared to a barrier of 200 turbines (Fig. 7), with a significant increment of energy, depending on the exploitable marine energy, *extension and number of the propellers*.

The production of electricity, from 5 ÷ 10 GWh/km per year, supports the maintenance, amortization, public lighting and domestic utilities of coastal municipalities, also through renewable dispatching.

As their lifespan is at least 20 years, there would be a very favorable economic recovery of the beach with probable maximum sizes of 1ha/km for beach activities.

This lifespan of the turbine barriers allows for the re-growth of vegetation (*matte*) and the restoration of the marine ecosystem, which is currently unfeasible through traditional defenses. The turbines do not produce waste (circular economy) as the floats can be recycled for the production of new turbines or, while still in service, can be transferred with a tug to defend other shorelines.

In any case the defense function of the barrier remains, even if it is not energized. The barrier, moreover, can be more economical when sandwiched with static breakwater silhouettes, of the Ferran type (1980) on the beach of S. Maria di Potenza (MC).

TURBINE PLANIMETRY

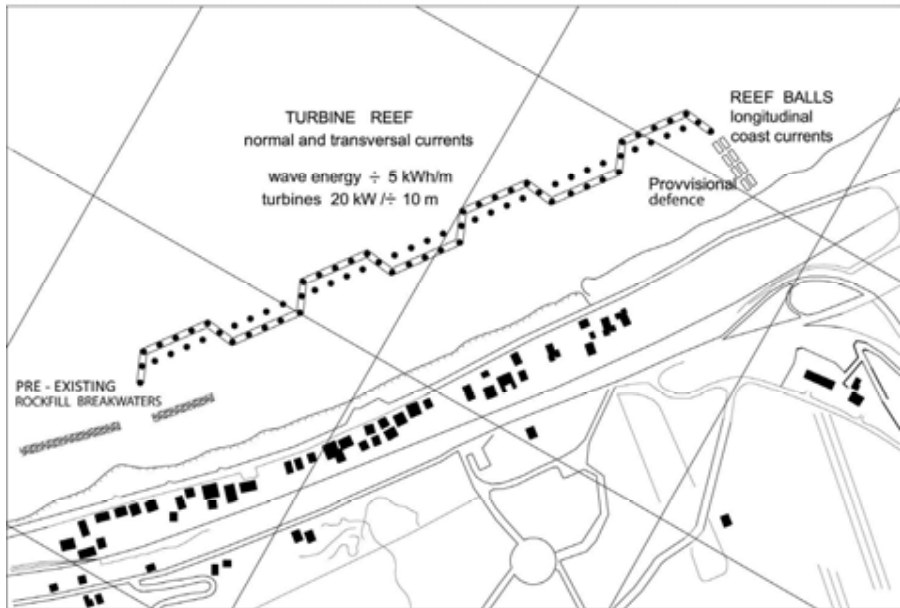

Figure 7 - Turbine planimetry and distribution, to be adapted to marine geomorphology and fetch in replacement of artificial nourishment and breakwaters. Both the comb shape and the reduction of the distances between turbines increases “Blue energy”; the distribution of the turbines also allow for depolluting filters. Littoral currents are damped by provisional reef balls or by static shapes similar to Ferran barriers, which are movable from terminal defence of each yard lot.

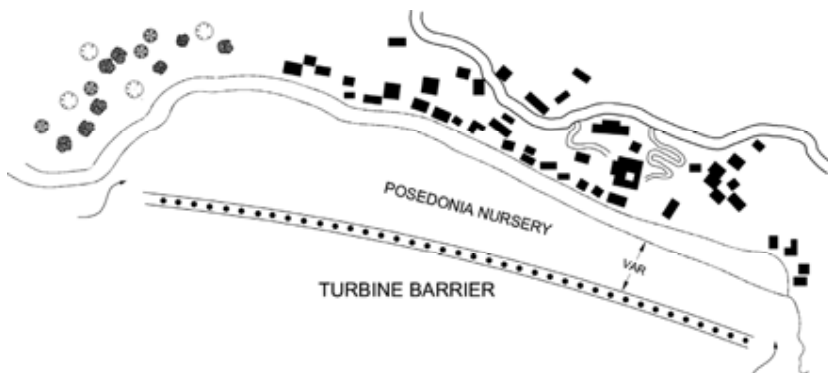

Figure 8 - A simplified protection, to shield from littoral currents, could consist of a barrier made only with a row of turbines in a bay between two promontories. It makes it possible to simplify experimental research of anti-erosion efficiency and electricity production efficiency.

The cost and correct executive control of construction of rockfill and nourishment is higher, especially considering that seasonal maintenance is considerably more than one million €/km/year, without any of the added advantages. This is especially the case if the beach is restored with forcibly extracted fine seabed sediments, which are quickly removed by winter storms, with exponential costs.

The turbine reef therefore becomes particularly competitive from an economic viewpoint in the *reconversion of current traditional defense* (Fig. 3 e 4).

This is especially true as regards annual maintenance, with a *public spending review* and the significant gains of beach establishments, which is proportionate to the hectares of beaches recovered and redeveloped.

Progressive fossil/renewable transition is favored by these energy barriers, especially if they are proposed in place of nourishment and rockfill breakwaters.

Currently in Italy (STES 2012) other turbines are utilized, such as propeller below raft (Kobold, Stretto di Messina), or articulated pulsator (40South Energy-Enel Green Power, Castiglione), or wave-air resonant columns in piers (Boccotti, Civitavecchia), or gyroscopic raft (Isvec-Eni, Ravenna), or multi-propeller in fluvial currents (Watercity Rovereto). There are also many other prototypes of marine energy international production (from Emec, Scotland to Eco Wave Power, Gibraltar).

The advantages highlighted support the financing of a gradual experimental research project. This would comprise the marine geomorphology, effective fetch, collection of data on marine currents, fluid dynamics simulation (CFD) and experimentation on a group of turbine prototypes in real size.

The research should be focused (Fig. 6 b, c) on the extension and shape and number of the propeller blades to be calibrated in function of the damping necessary to reduce the erosion in excess, according to the marine currents and selected seabed on a case-by-case basis. It is very important to study the historical dynamic evolution of the coast by means of comparative cartography and present-day satellite surveys (ISMAR-CNR webcam).

Furthermore, initial monitoring of the currents and geotechnical tests need to calibrate the foundations of the turbines instrumented with telewattmeters.

The experimental study of *erosion control and energy efficiency* is based on observational methods (NTC2018), similar to landslide stabilization.

Above all the center distance of the comb planimetry and shape of the barrier must be calibrated (Fig. 7). This is simplified for bays, where littoral currents do not affect erosion (Fig. 8). It should be noted that financing in Europe and in China regarding the production of marine energy (WEC Wave Energy Converter) is in full development.

It is important to promote Italian Research (CNR Fig. 6), whether for Start Ups, or Benefit Corporations which are active above all in Europe-Africa.

4 Conclusion: Benefits of the Research

The rise in beach levels and the limitation of coastal erosion represent the principal economic benefits. Also worth mentioning are the long lifespan and very low maintenance costs of barriers and the reduction in sea current speed, with the consequent natural deposition of suspended sand. Not only is there parallel power production, but the

turbines dampen only speed current in excess, induced by anthropizations, thereby allowing for natural summer/winter mobile erosion.

Sand extraction is eliminated and there are no detrimental effects with regard to the new soft defense against erosion, as opposed to nourishment and rockfill breakwaters.

Turbine location after the calm zone, due to offshore/inshore energy conversion and away from sea storms, make it possible to reduce maintenance costs.

Other benefits are the fact that the kinetic energy of the sea on the new floating turbines, which turn with minimum currents, is competitive with eolic turbines.

The type and superior number of the propellers makes it possible to increase the power in each turbine. The monoblock of the turbines are produced by 3D printers, with metal powder recycled scrap.

As well as marine ecosystem recovery and consequent decontamination and landscape retraining, engraftment of a marine grassland nursery prevents sea bed erosion, and the coastal limits to fishing and recreational boating increase swimmers safety. The levels of beaches and river delta banks are increased to prevent flooding caused by rising sea levels.

Marine energy production for new barriers covers the cost of maintenance and amortization and there are significant economic benefits and landscape retraining through the recovery of hectares of beaches, which has a high economic value.

It is also important to underline that economical reconversion of the existing artificial nourishment and rockfill breakwater protection to new turbine reefs results in a significant reduction in public spending on coastal defense maintenance. The operative life of the energized reef, which is approximately 20 years, is regenerable in new defense.

Given their long lifespan, the barriers allow for the engraftment of marine grasslands, which prevents erosion. The reef can then be transferred to another seabed after regrowth of the posidonia and beach stabilization.

Electricity production in particular for lighting of the coastal municipalities, increases safety at night. Energy storage can be hydraulic, by reverse turbines pumping water to a higher altitude, if close to the coast, or hydrogen production by nanotube electrolysis.

The elimination of emerged rockfill breakwaters prevents eutrophication and promotes seabed decontamination. The new barrier should mitigate the effects of climate change in the coming decades.

The barrier is equipped with seabins to remove garbage, as well as sensors for chemical control, depolluting filters and oxygenation. Good water quality will mean that the beach can boast “blue flags”.

The barrier can be reinforced with two nets to form a ribbon-like aquarium nursery, so that the fish are not over-concentrated.

The crushing of the rockfill boulders into sand and fine gravel allows for appropriate particle size nourishment and landscape retraining.

The barriers limit recreational navigation to a safe distance from the shore.

The turbines could be purchased by boat owners, or charging column prosumers.

As they have an indifferent relative mass to water, which avoids resonance, they are also operational during and following earthquakes.

When protected with rakes, turbines can also be used in rivers, especially in deltas and during the mascaret.

The barriers would also make a contribution to the transition from fossil to renewable energy, and to new coastal defenses.

There would be new training and jobs in coastal defense, auditing, and marine propeller design: in fact, a 10 % re-conversion of scrapped cars to turbines could defend 100 km of Italian beaches.

The risk of sea storm damage to the turbine foundations is prevented by their particular inshore location and in any case by the strong tripod truss.

Corrosion and descaling risk are prevented by standard marine protections, and by the fact that the dynamo-propeller-floating monoblocks can be easily removed from the shafts for cleaning and maintenance.

5 References

- [1] Atzeni A. (2011) - *Regime e Protezione dei Litorali*, Aracne Editrice, Roma.
- [2] Boussinesq J. (1987) - *Théorie de l'écoulement tourbillonnant et tumultueux des liquides dans les lits rectilignes à grande section*, Ed. Gauthier -Villars e fils, Paris.
- [3] Chiocci F. L. (2016) - *Geologia Marina*, Società Geografica Italiana, Roma
- [4] Ciavola P., Armaroli C., Harley M, (2011) - *Soglie critiche delle mareggiate: un modello da esportare a scala nazionale?* Coastal Processes Research Unit (COPRU), Univ. Ferrara.
- [5] Dini E. (2020) - *Costruzione di barriere coralline tramite stampante D-shape*, Camicasca S. 19 marzo articolo Avvenire.
- [6] Falconi I. (2018) - *Analisi dei fattori predisponenti l'erosione delle spiagge e le inondazioni fluviali in alcune aree del Lazio*, Tesi di Laurea in Geologia, Ed.3a.
- [7] Ferro G. (1970) - *Costruzioni Marittime*, pp.328, 2^a Ed. Cedam, Padova.
- [8] ISMAR-CNR Istituto di Scienze Marine: *banche dati*, www.ismar.cnr.it.
- [9] Marsella L., et al. (1986) - *Le praterie sommerse del Mediterraneo*, Laboratorio di Ecologia del Benthos, Ischia, Stazione Zoologica Anton Dohrn, Napoli.
- [10] Mas-Pla J., Zuppi G. M. (2009) - *Gestione ambientale integrata de áreas costeras*, European and Latin American Network on Coastal Area Management, Rubes Editorial.
- [11] Mattm-Regioni (2016) - *Linee Guida Nazionali per la difesa della costa dai fenomeni di erosione e dagli effetti dei cambiamenti climatici*, Tavolo Nazionale sull'Erosione Costiera, con il coordinamento tecnico di ISPRA per il Ministero dell'Ambiente della Tutela del Territorio e del Mare.
- [12] Morison, J. R.; O'Brien, M. P.; Johnson, J. W.; Schaaf, S. A. (1950) - *The force exerted by surface waves on piles*, Petroleum Transactions, American Institute of Mining Engineers, 189: 149–154, [doi:10.2118/950149-G](https://doi.org/10.2118/950149-G).
- [13] Palmarocchi M, Ventura P. (2018) - *Energia marina e Difesa delle Coste*, Uomo, ambiente, lavoro: per un'ecologia integrale, Fondazione Ut Vitam Habeant, a cura di Cardinal Elio Sgreccia, Ed. Cantagalli Siena, pp.113 - 153.ISBN 88-6879-543-6
- [14] Palmarocchi M., Ventura P. (2020) - *New defense of the coasts to prevent the sea level rising also*, Atti dei Convegni Lincei 334, XXXVI Giornata dell'Ambiente: Variazioni del livello del mare dovute ai cambiamenti climatici, Bardi Edizioni, Roma 7 nov. 2018, pp.43-47 ISSN0391-805X, ISBN 978-88-218-1198-2. Poster - *New defense of the natural nourishment and seabed grassland*, XIX Giornata Gestione difesa delle coste, Roma 21 mar 2019, www.steseoetica.it.
- [15] Ricci Lucchi F. (1992) - *I Ritmi del Mare*, pp. 251, La Nuova Italia scientifica, Roma.

- [16] Ranjan Vepa, (2013) - *Dynamic Modeling, Simulation and Control of Energy Generation*, pp.337, Springer Science & Business Media.
- [17] STES, Aghape (2012) - *Energia dal mare*, Stato dell'Arte Auditorium CISL, 7 giugno Roma.
- [18] Ventura P. (1992) - *Prove su modello di frangiflutti galleggiante per la difesa dall'erosione delle coste*, 3 AIOM Congress on marine and offshore engineering, 7-8-9 giugno, Genova, 59-66.
- [19] Ventura P., Palmarocchi M. (2019) - *New defense of the coasts to prevent the sea level rising also*, video (www.steseoetica.it) screened in Catholic University of America, Eleventh International Conference on Climate Change, Impacts & Responses, Coastal Resilience, 16 -17 april Washington.
- [20] Ventura P., Palmarocchi M. (2019) - *Nuova difesa del ripascimento naturale e delle praterie Marine*, database CNRSOLAR 9861TR2019.
- [21] Ventura P. (2019) - *Fondazioni: Modellazioni statiche e sismiche*, vol. I, pp. 777 Ulrico Hoepli Editore, Milano, ISBN 978-88-203-8644-3.
- [22] Ventura P. (2019) - *Fondazioni: Applicazioni statiche e sismiche*, vol. II, pp. 782; 20 Ulrico Hoepli Editore, Milano, ISBN 978-88-203-8645-0

INDEX OF AUTHORS

Akçali B.	475	Çalık H.	475
Akyol O.	475	Caloiero T.	338
Allasia P.	17	Cantasano N.	338
Altavilla S.	155	Carboni D.	194
Angelini F.	688	Cardellicchio N.	392
Annibaldi A.	705	Carleo D.	28
Aragonés L.	432, 441	Carranza M.L.	529
Artuso F.	688	Casu A.	174
Asta A.	117	Cazzani A.	183
Atabay H.	632	Ceccarelli J.	155
Atroune F.	422	Cellini E.	620
Baibai T.	547	Cera G.	7
Bañón L.	432	Chiti M.	316
Barontini S.	183	Chiuchiarelli I.	529
Barra E.	610	Ciarravano A.	17
Beccarisi L.	483	Ciccarese G.	586
Beck A.L.	412	Cioffi A.	656
Bedini M.	492	Colantoni P.	379
Bedini R.	379, 492	Colarossi D.	666
Bellia A.F.	501	Colella S.	688
Bellissimo G.	510, 519	Coletta V.	17
Benincasa F.	XVII	Conte A.	557
Bisiani T.	164	Contini M.	194
Bonazza A.	17	Corbau C.	194
Bono A.	645	Corniello L.	28
Bosi F.	229	Corrente G.	155
Brando V.E.	688	Crespi M.	17
Bresciani M.	713	Cuculo F.	656
Bulkan O.	385	D'Andria G.	483
Buonocunto F.P.	392	D'Antonio C.	580
Burda A.	28	D'Antonio P.	580
Caligiore A.	155	Damm A.	688

Dauvin J.C.	309	Filipponi F.	557
De Angelis A.	597	Fiorani L.	688
De Carolis G.	713	Fiorini L.	363
De Cicco A.	28	Fontana M.	69
de Francesco D.	38	Fornaro G.	713
de Francesco M.C.	38, 529	Frate L.	529
De Marchi D.	214	Furčić N.	462
De Santi F.	713	Galeano F.	155
De Vincenzi M.	XVII, 676	Gargiulo M.	28
Del Corona A.	105, 280	Gazale V.	194
Devescovi V.	348	Genangeli A.	688
Di Cicco A.	688	Gherzi A.	242
Di Deo N.	557	Ghirardi N.	713
Di Leo A.	392	Giandomenico S.	392
Di Natale M.	402	Giannuzzi C.G.	483
Di Nucci L.	656	Giansante C.	557
Di Ronza S.	402	Giardino C.	713
Dietrich S.	17	Giordano L.	392
Dieudonné E.	569	Girolametti G.	705
Droit J.	698	Giudici G.N.M.	250
Epifani F.	219	Gomes da Silva P.	412
Eramo C.	402	Goossens A.	569
Errhif A.	547	Greco M.	483
Esposito E.	392	Grigatti G.	79
Esposito M.A.	229	Grindlay A.	95
Ettahiri O.	547	Guerrero F.	28
Evans J.	501	Gupana R.	688
Evcen A.	475	Hartmann V.	569
Fabrizio F.	47	Hilmi K.	547
Fagnano A.	597	Hoarau E.	597
Fai S.	451	Humeniuk H.	540
Faraone A.	38	Idmoussi H.	547
Fasano G.	XVII, 676	Illuminati S.	705
Federico S.	17	Ippoliti C.	557
Ferrari I.	58	Ivona A.	85
Ferraro L.	392	Jannuzzi F.	250
Figueredo F.	705	Jones M.	412

Kadri I.	422	Niceta Poti M.M.	586
Kaman G.	475	Notti D.	17
Kļaviņš D.	597	Orlando G.	656
Lacetra E.	580	Pagán J.I.	432, 441
Lai A.	688	Pagliani T.	529
Lalli M.	214	Palano I.	105, 280
Lanfranco S.	501	Palmarocchi M.	723
Lapierre B.	569	Paluzzi M.	38
Lazarou A.L.	194	Pappacena G.	155
Lenfant P.	569	Patrizio S.	250
Lento G.P.	28	Pellegrini A.	117
Lolli I.	259	Pellicone G.	338
Longo A.	586	Pergent-Martini C.	379
López I.	432, 441	Peruccio P.P.	79
Luciani G.	713	Petrachi S.	586
Makaoui A.	547	Petrillo A.	155
Mancini A.	214	Petrini M.	557
Mangifesta M.	38	Piccioli-Resta G.	451
Marini M.	645	Picciolo A.	451
Martín R.	95	Pichi F.	105, 280
Martinez Sanchez J.	412	Pidalà A.M.	289
Marucci A.	363	Pikelj K.	462
Masucci P.	610	Pioch S.	309
Mazzeo G.	270	Pirrerà L.	620
Mecca S.	610	Pisani Massamormile F.	250
Medina Santamaria R.	412	Pisconti M.	155
Miccio A.	597	Polat Beken Ç.	632
Miglietta F.	688	Pollice F.	219
Milia A.	392	Prestileo F.	17
Minareci E.	632	Pribelja L.	597
Minareci O.	632	Principi P.	666
Minciarelli C.	38	Puri P.	155
Montioni L.	105, 280	Quarta A.	58
Morel M.	569	Rodani V.	348
Moura É	597	Romano B.	363
Namık Çağatay M.	385	Romano F.V.	580
Natale A.R.	38	Rottino F.	155

Rueda L.	597	Susmel S.	705
Rugge C.	586	Tagarelli G.	338
Russo M.	299	Taji A.	412
Ruvolo V.	510, 519	Tan I.	632
Said A.E.	597	Tartara P.	127
Salaün J.	309	Taşkın E.	475, 632
Salini R.	557	Tatasciore G.	38
Salvadori E.	492	Tenza-Abril A.J.	432, 441
Santoleri R.	688	Tora S.	557
Saragosa C.	316	Torcasio R.C.	17
Savron M.	164	Trematerra A.	28
Scalcione V.	580	Trigona S.L.	137
Scamosci E.	557	Truzzi C.	705
Scamporrino M.	105, 280, 326	Ubaldi C.	155
Scatigna G.	155	Vasseur L.	569
Sgambati D.	597	Ventura P.	723
Simeone M.	610	Venudo A.	348
Simeoni U.	194	Verdoit-Jarraya M.	569
Simione F.	155	Violante C.	392
Sinesi T.	155	Voloshyn O.	540
Sirchia B.	510, 519	Voloshyn V.	540
Solano M.	610	Yalamaz N.	385
Somoue L.	547	Yepes V.	95
Spaccavento G.	155	Zaccagna J.	174
Spada L.	392	Zamparelli V.	713
Stanisci A.	529	Zappalorto M.	38
Stocco R.	620	Zullo F.	363

The 8th International Symposium *Monitoring of Mediterranean Coastal Areas. Problems and Measurements Techniques* was organized by CNR-IBE in collaboration with FCS Foundation, and Natural History Museum of the Mediterranean and under the patronage of *University of Florence, Accademia dei Geografi, Tuscany Region and Livorno Province*. It is the occasion in which scholars can illustrate and exchange their activities and innovative proposals, with common aims to promote actions to preserve coastal marine environment. Considering Symposium interdisciplinary nature, the Scientific Committee, underlining this holistic view of Nature, decided to celebrate Alexander von Humboldt; a nature scholar that proposed the organic and inorganic nature's aspects as a single system. It represents a sign of continuity considering that in-presence Symposium could not be carried out due to the COVID-19 pandemic restrictions. Subjects are related to coastal topics: morphology; flora and fauna; energy production; management and integrated protection; geography and landscape, cultural heritage and environmental assets, legal and economic aspects



PATRONAGE BY



ISSN 2704-601X (print)
ISSN 2704-5846 (online)
ISBN 978-88-5518-147-1 (PDF)
ISBN 978-88-5518-148-8 (XML)
DOI 10.36253/978-88-5518-147-1