

GEMATON: LIVING AND DYING IN A KUSHITE TOWN ON THE NILE

Volume III

The Pottery



Isabella
Welsby Sjöström

SUDAN ARCHAEOLOGICAL RESEARCH SOCIETY
PUBLICATION NUMBER 29

**GEMATON: LIVING AND DYING IN A KUSHITE
TOWN ON THE NILE**

Volume III

The Pottery

Isabella Welsby Sjöström

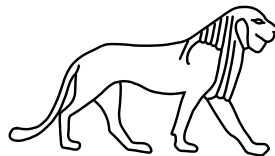

SARS
LONDON
2023



ARCHAEOPRESS PUBLISHING LTD

Summertown Pavilion
18-24 Middle Way
Oxford OX2 7LG

www.archaeopress.com

Sudan Archaeological Research Society

Publication Number 29

Editor of this volume: D. A. Welsby

ISBN 978-1-80327-678-6

ISBN 978-1-80327-679-3 (e-Pdf)

© The Sudan Archaeological Research Society and Archaeopress 2023

Front cover: A selection of pottery forms from Kawa

Back cover: Sorting the pottery at Kawa



This work is licensed under the Creative Commons Attribution-NonCommercial-NoDerivatives 4.0 International License. To view a copy of this license, visit <http://creativecommons.org/licenses/by-nc-nd/4.0/> or send a letter to Creative Commons, PO Box 1866, Mountain View, CA 94042, USA.

This book is obtainable from The Sudan Archaeological Research Society
c/o Department of Egypt and Sudan, The British Museum, London WC1B 3DG
or from the Society's website <http://www.sudarchrs.org.uk>

Also available direct from Archaeopress or from our website www.archaeopress.com

**GEMATON: LIVING AND DYING IN A
KUSHITE TOWN ON THE NILE**

Volume III

The Pottery

Contents

List of Tables	VIII
List of Figures	IX-XII
List of Plates	XIII-XIV
Acknowledgements	XV
1. Introduction	1
2. Discussion of the fabrics found in the town and cemetery	2-20
Manufacturing techniques	2
The quantity and proportional presence of the fabrics	2
Explanations to the Fabric Descriptions and Table 2.1	3
3. The Forms	21-305
Categories of vessels	21
Abbreviations	21
Pot codes	21
Manufacture	22
Colours	22
A note on the arrangement of the pottery	22
3.1. Amphorae, Napatan	22
3.2. Imported Amphorae, Napatan jars, Meroitic beer jars and miscellaneous flasks, jugs and bottles	42
3.3. Jars, both handmade and wheel-made, pigeon pots	67
3.4. Open-mouthed jars	85
3.5. Miscellaneous open-mouthed jars	102
3.6. Decorated wares, cups, open bowls and basins, handmade and wheel-made	113
3.7. RBRIE; Coarseware dishes, bowls and cooking pots; miscellaneous basins with everted rims	143
3.8. Ware 910 and similar coarsewares	194
3.9. <i>Doka</i> , bread platters, ovens, and flat-based basins	228
3.10. Beakers and offering dishes	250
3.11. Incense burners and miscellaneous forms	270
3.12. Bases and handles	293
4. Decoration on the ceramic vessels at Kawa	306-330
Discussion	306
4.0. Not illustrated here, but present on the forms	307
4.1. Thickened bases, basket impression, bosses/lugs	307
4.2. Bosses, rim-top and below rim decoration	307
4.3. Incised, impressed and rocker stamped decoration	307
4.4. Incised and moulded coarseware decoration and faunal appliqués	308
4.5. Impressed, roulette and rocker-stamped decoration	308
4.6. 1204y and variations with slip decoration	308
4.7. Slip decoration, stamped and painted Meroitic fineware decoration, as well as symbols on beer jars	308
4.8. Painted decoration on Meroitic jars.	308
4.9. Painted decoration on Meroitic jars.	308
5. The Graffiti and Pot Marks	331-350
A Carian connection?	331
<i>Tituli picti</i>	332

Discussion of the graffiti and other marks	332
5.1. Symbols and/or ‘Greek’, or Carian, letters	332
5.2. Letters and/or symbols (cont.)	332
5.3. Letters and/or symbols (cont.)	332
5.4. Napatan and Meroitic graffiti and symbols	332
5.5. Linear symbols, <i>tituli picti</i> , and potter’s marks	333
5.6. Graffiti of the ‘grid’ type on Napatan amphorae in particular	333
5.7. Further variations of the grid motif on Napatan amphorae	333
5.8. Variations of the grid motif and more freestyle designs	333
5.9. Random (?) scratches and rectangular motifs	334
5.10. Particularly fragmentary marks	334
5.11. Animals in the graffiti and composite scenes	334
6. The Napatan amphorae from Building F1	351-361
Dating	353
Notes to Table 6.1, Figures 6.2 and 6.3 and Plates 6.5 and 6.6	353
7. The pottery finds from Site R18	362-380
Conclusion	363
Presentation of the pottery belonging to the graves	363
Grid square (GD3)	363
Area (HA1)	365
Grid square (HA2)	365
Area J	367
8. Miscellaneous Features	381-385
Distinct wares or groups with similar characteristics	381
820 & 822	381
RBR	381
Ware 910	381
CRR	382
Wasters and unfired vessels – a clue to pottery production at Kawa?	382
Repairs – mending holes	382
Other holes, pre- and post-firing	383
Vessels found <i>in situ</i>	383
Reused vessels	383
Volume	384
9. Discussion of the chronology and character of the assemblages by area	386-389
Area A	387
Buildings A1-A6	387
Area B	388
Area C	388
Area F	388
The two kilns and surroundings	388
Building F1	388
(FZ1) – Building F4	389
(FZ2) – Street	389
Area T	389
(TG5) – Gateway into the <i>temenos</i>	389
Area Z	389
(ZH5) and (ZI6), Building Z1	389
Site R18	389
Note on other dating	389

10. Concluding remarks	390-392
The functions of the Kawa ceramics	390
The issue of imported Nile clay wares from Egypt vs. locally produced wheel-made forms	391
Other imported pottery types	391
Future direction of research	391
11. Bibliography for Volume III	393-396

List of Tables

2. Discussion of the fabrics found in the town and cemetery	
2.1. The fabrics in numerical order.	16-20
3. The Forms	
3.1. Napatan amphorae and other narrow-necked jars.	36-41
3.2. Imported amphorae, Napatan jars, Meroitic beer jars and miscellaneous flasks, jugs and bottles.	62-66
3.3. Jars, both handmade and wheel-made, pigeon pots.	79-84
3.4. Open-mouthed jars.	98-101
3.5. Miscellaneous open-mouthed jars.	109-112
3.6. Decorated wares, cups, open bowls and basins, handmade and wheel-made.	130-142
3.7. RBRIE; Coarseware dishes, bowls and cooking pots; miscellaneous basins with everted rims.	173-193
3.8. Ware 910.	215-227
3.9. <i>Doka</i> , bread platters, ovens and flat-based basins.	244-249
3.10. Beakers and offering dishes.	260-269
3.11. Incense burners and miscellaneous forms.	287-292
3.12. Bases and handles.	300-305
4. Decoration on the ceramic vessels at Kawa	
4.1. Types of Decoration.	321-330
5. The Graffiti and Pot Marks	
5. Graffiti and pot marks.	347-350
6. The Napatan amphorae from Building F1	
6.1. The amphorae and graffiti unique to Building F1.	359-360
6.2. Napatan amphorae forms not unique to Building F1.	361
7. The pottery finds from Site R18	
7.1. Individual graves.	363
7.2. Graves in grid square (GD3).	364
7.3. Graves in Area (HA1).	365
7.4. The graves in grid square (HA2).	366
7.5. Graves in Area J, with and without monuments.	368-369
8. Miscellaneous Features	
8.1. Slipped vessels found across Sites Q3 and R18.	381
8.2. Presence of RBRIE and variants across the site, arranged in ascending order according to RVE percentage.	381
8.3. Presence of 910 found across Sites Q3 and R18.	381
8.4. Presence of CRR (crackled rims) found across Site Q3. None were found in Site R18.	382
8.5. Average weights of a selection of forms.	384
9. Discussion of the chronology and character of the assemblages by area	
9.1. The proportion of wheel-made and handmade pottery found across Sites Q3 and R18.	387
9.2. Breakdown of the handmade and wheel-made pottery from Site R18, showing also RVE percentages.	387

List of Figures

3. The Forms

3.1.1. Miscellaneous amphora (?) rims (scale 1:4).	25
3.1.2. Typical Napatan amphora rims and variants (scale 1:4).	26
3.1.3. Variants of Napatan amphora rims (scale 1:4).	27
3.1.4. Napatan amphorae with squat rims (scale 1:4).	28
3.1.5. Napatan amphorae with thin and delicate rilling (scale 1:4).	29
3.1.6. Napatan amphorae, with varying inclination of the rim, forming a short neck (scale 1:4).	30
3.1.7. Examples of the larger size of Napatan amphorae (scale 1:4).	31
3.1.8. Variations on the squat rim of the larger size Napatan amphorae and variants thereof (scale 1:4).	32
3.1.9. Bases of Napatan amphorae (scale 1:4).	33
3.1.10. Jars, apparently without handles, with beaded rims and short necks (scale 1:4).	34
3.2.1. Imported Amphorae, from Egypt and beyond: Levantine/Canaanite amphorae, rim of Aegean amphora and Dressel 2-4, table variant (scale 1:4).	45
3.2.2. Jars with beaded rims and narrow necks, narrow diameter at shoulder (scale 1:4).	46
3.2.3. Beaded, narrow necked jars, continued; miscellaneous flagons and jars with flanged, complex and plain rims (scale 1:4).	47
3.2.4. Beer jars with beaded rims, some with painted bands (scale 1:4).	48
3.2.5. Beer jars with beaded rims, slipped and with painted decoration (scale 1:4).	49
3.2.6. Beer jars with beaded and plain rims, shoulder increasingly less pronounced (scale 1:4).	50
3.2.7. Beer jars with rim sloping into shoulder (scale 1:4).	51
3.2.8. Ovoid storage jars with sloping shoulders and narrow, straight necks (scale 1:4).	52
3.2.9. Meroitic large storage jar with vertical neck. <i>Krater</i> and similar rims and a possibly associated handle (scale 1:4).	53
3.2.10. Globular jars with vertical narrow necks, globular painted jars and 2-handled flagon (scale 1:4).	54
3.2.11. Flagons, bottles and pilgrim bottles, <i>clepsydra</i> rims; miscellaneous beaded and/or everted rims (scale 1:4).	55
3.2.12. Everted amphora rims, beaded jug rims and small to medium restricted vessels with beaded rims (scale 1:4).	56
3.3.1. Restricted and open-mouthed jars (scale 1:4).	69
3.3.2. Wheel-made closed jars with triangular /bevelled rim (scale 1:4).	70
3.3.3. Handmade closed jars with short necks and beading variations (scale 1:4).	71
3.3.4. Plain beaded open-mouthed and restricted jars of varying size (scale 1:4).	72
3.3.5. Handmade jars with plain rims and no or short neck (scale 1:4).	73
3.3.6. Handmade jars with short neck (scale 1:4).	74
3.3.7. Crude handmade storage jars, some with externally roughly thickened body (scale 1:4).	75
3.3.8. 'S'-shaped jar rims, handmade and wheel-made (scale 1:4).	76
3.3.9. Open-mouthed jars with beaded rims; open-mouthed jars with angular, square rims (scale 1:4).	77
3.3.10. Open mouthed jars, mainly wheel-made. Open and closed jars with lid seating (scale 1:4).	78
3.4.1. Open-mouthed jars with variants of beading, with handles or lugs (scale 1:4).	86
3.4.2. Open-mouthed jars (scale 1:4).	87
3.4.3. Double-beaded jar rims (scale 1:4).	88
3.4.4. Double-beaded rims, vertical sides (scale 1:4).	89
3.4.5. So-called pigeon pots, possible rims and bases (scale 1:4).	90
3.4.6. Deep bead-rimmed bowls, many with suspension holes (scale 1:4).	91
3.4.7. Open-mouthed wheel-made jars with beaded rims (scale 1:4).	92
3.4.8. Basins with beaded rims, vertical sides and horizontal or vertical handles (scale 1:4).	93
3.4.9. Deep basins with ledge rims, some with handles (scale 1:4).	94
3.4.10. Basins with vertical or inverted rims (scale 1:4).	95
3.4.11. Handmade and wheel-made storage jars. 2719b, 2792, 2821, 4649 and 4650 are at scale 1:8, others at 1:4.	96
3.5.1. Deep jars with beaded rims, occasionally(?) with handles (scale 1:4).	103
3.5.2. Buttressed, ledge rim basins; some similar rim forms without the buttress (scale 1:4).	104
3.5.3. Jars with 'S'-shaped profile (scale 1:4).	105
3.5.4. Bell jars (scale 1:4).	106
3.5.5. Bell jars (scale 1:4).	107
3.5.6. Deep bowls with everted, beaded rims (scale 1:4).	108
3.6.1. Decorated wares, especially Meroitic; also miscellaneous Neolithic and Kerma period forms (scale 1:4).	116

3.6.2. Bowls and cups of Napatan and Meroitic date (scale 1:4).	117
3.6.3. Wide-mouthed bowls and dishes (scale 1:4).	118
3.6.4. Beakers and deep plain bowls (scale 1:4).	119
3.6.5. Carinated bowls (scale 1:4).	120
3.6.6. Cups and miscellaneous bowls with groove by rim (scale 1:4).	121
3.6.7. Bowls with ribbing by rim (scale 1:4).	122
3.6.8. Bowls with ribbing by rim, continued from Figure 3.6.7 (scale 1:4).	123
3.6.9. Ribbed ware and bowls with flanges and bosses (scale 1:4).	124
3.6.10. Bowls with everted decorated rims (scale 1:4).	125
3.6.11. Bowls with ledge or beaded rims (scale 1:4).	126
3.6.12. Bowls and basins with ledge rims (scale 1:4).	127
3.7.1. RBRIE jars (scale 1:4).	145
3.7.2. RBRIE deep bowl with 'S'-shaped profile (scale 1:4).	146
3.7.3. RBRIE miscellaneous bowls (scale 1:4).	147
3.7.4. RBRIE bowls and beakers with inverted rims (scale 1:4).	148
3.7.5. RBRIE bowls and beakers with vertical sides (scale 1:4).	149
3.7.6. RBRIE bowls and beakers with 'S'-shaped profile (scale 1:4).	150
3.7.7. RBRIE bowls with everted sides and dishes (scale 1:4).	151
3.7.8. Rims of coarseware bowls/cooking pots (scale 1:4).	152
3.7.9. Cooking pots, complete profiles (scale 1:4).	153
3.7.10. Cooking pots with thickened bases, including wheel-made variants (scale 1:4).	154
3.7.11. Cooking pots continued and decorated deep bowls (scale 1:4).	155
3.7.12. Cooking pots with decorated rims (scale 1:4).	156
3.7.13. Cooking and storage vessels with finger-impressed decoration 1012y (scale 1:4).	157
3.7.14. Thick-walled cooking pots with inverted rims (scale 1:4).	158
3.7.15. Coarseware bowls with straight sides (scale 1:4).	159
3.7.16. Vertical sided large bowls (scale 1:4).	160
3.7.17. Various vessels with angular rims and open-mouthed coarsewares (scale 1:4).	161
3.7.18. Variations on beaded rims, vertical sides (scale 1:4).	162
3.7.19. Beaded or flanged rims, everted deep bowls or basin forms (scale 1:4).	163
3.7.20. Miscellaneous dishes and bowls, various rim forms, including lid-seating (scale 1:4).	164
3.7.21. Dishes with beaded and plain rims (scale 1:4).	165
3.7.22. Coarseware bowls with rolled-over and plain rims; basket impression 200y (scale 1:4).	166
3.7.23. Large open bowls and basins (scale 1:4).	167
3.7.24. Miscellaneous basins (scale 1:4).	168
3.7.25. Everted basin forms with squared-off rims (scale 1:4).	169
3.8.1. Deep coarseware bowls with 'S'-shaped profile (scale 1:4).	195
3.8.2. 'S'-shaped profiles, continued (scale 1:4).	196
3.8.3. Coarseware bowls, some with holes pierced in the base; miscellaneous forms with inverted sides (scale 1:4).	197
3.8.4. Coarseware bowls with inverted rims (scale 1:4).	198
3.8.5. Coarseware bowls or cooking pots with vertical sides and plain rims (scale 1:4).	199
3.8.6. Deep everted coarseware medium sized bowls and small cups or bowls (scale 1:4).	200
3.8.7. Open coarseware bowl forms (scale 1:4).	201
3.8.8. Coarseware bowls with beaded rims, everted plain rims and everted flanged rims, and a very deep, rimless body (scale 1:4).	202
3.8.9. Deep coarseware cooking pots, with lid seating variations (scale 1:4).	203
3.8.10. Coarseware bowls with various forms of lid seating (scale 1:4).	204
3.8.11. Deep coarseware bowls with flanged rims (scale 1:4).	205
3.8.12. Coarseware closed jars with some form of beading or flattening of the rim top (scale 1:4).	206
3.8.13. Deep coarseware bowls with vertical sides and internal or external beading (scale 1:4).	207
3.8.14. Basins with appliqué on rim, and similar forms, possibly without. (scale 1:4).	208
3.8.15. Deep coarseware bowls and basins (scale 1:4).	209
3.8.16. Shallow coarseware bowls and dishes (scale 1:4).	210
3.8.17. Deep dishes with flanged rims; deep bowls with beaded or flanged rims (scale 1:4).	211
3.8.18. Deep, open coarseware basins (scale 1:4).	212
3.8.19. Deep coarseware basins, continued (scale 1:4).	213
3.9.1. 'Doka'-like dishes (scale 1:4).	230
3.9.2. 'Doka'-like dishes (scale 1:4).	231
3.9.3. 'Doka'-like dishes (scale 1:4).	232
3.9.4. 'Doka' and miscellaneous basin or bin rims (scale 1:4).	233

3.9.5. Large platters and/or bin lids (scale 1:4).	234
3.9.6. Bread platters and small basins with flat bases (scale 1:4).	235
3.9.7. Basins, some possibly deep bread moulds (scale 1:4).	236
3.9.8. Oval basin with two crocodile appliqués. Basin 4639x and spouted 'vessel' 3367x are at scale 1:8, others at 1:4.	237
3.9.9. Bin and coarse bowl rims (scale 1:4).	238
3.9.10. Bin and basin rims, coil-built (scale 1:4).	239
3.9.11. Bread oven rims (scale 1:4).	240
3.9.12. Bread ovens. 4637x and 2890x are at scale 1:8, others at 1:4.	241
3.9.13. Large lid handles (scale 1:4).	242
3.10.1. Beakers with rounded bases (scale 1:4).	252
3.10.2. Various beakers, including ones with flat bases (scale 1:4).	253
3.10.3. Small beakers, tall beakers and various beaker bases (scale 1:4).	254
3.10.4. Rounded beaker bases and flat-based beakers (scale 1:4).	255
3.10.5. Flat-based cups (scale 1:4).	256
3.10.6. Flat-based dishes and carinated bowls (scale 1:4).	257
3.10.7. Round-based dishes (scale 1:4).	258
3.11.1. The largest of the braziers/incense burners (scale 1:4).	273
3.11.2. Incense burners and/or braziers (scale 1:4).	274
3.11.3. Wheel-made incense burners, medium and large size (scale 1:4).	275
3.11.4. Handmade incense burners and or braziers (scale 1:4).	276
3.11.5. Handmade incense burners (scale 1:4).	277
3.11.6. Incense burners and or braziers, similar forms with open or closed profile (scale 1:4).	278
3.11.7. Pot stands and bread cones (scale 1:4).	279
3.11.8. Feeder cups, spouts, possible lamp and goblet forms (scale 1:4).	280
3.11.9. Crucibles, possible lamps, miniature pots, unusual bases (scale 1:4).	281
3.11.10. Lids, animal appliqués and special forms with 'legs' (scale 1:4).	282
3.11.11. Miscellaneous form with unclear function (scale 1:4).	283
3.12.1. Miscellaneous rounded bases (scale 1:4).	295
3.12.2. Amphora bases, rounded bases, omphalos and flat bases (scale 1:4).	296
3.12.3. Ring-footed bases (scale 1:4).	297
3.12.4. Miscellaneous handles, especially of amphorae or jugs/flagons (scale 1:4).	298
3.12.5. Miscellaneous handles, especially. but not exclusively, from handmade vessels; lugs/bosses (scale 1:4).	299

4. Decoration on the ceramic vessels at Kawa

4.1. Random surface finishes and basket impressions; practical features, such as a colander and lug handles; variations of piecrust decoration. 1004y is at scale 1:4, others are at 1:2	310
4.2. Bosses, rim decoration and decoration just below the rim (scale 1:2).	311
4.3. Impressed, incised and rocker-stamped motifs (scale 1:2).	312
4.4. Incised and moulded coarseware decoration and appliqués (scale 1:2).	313
4.5. Impressed and rocker-stamped decoration across the vessel body, mostly Meroitic period (scale 1:2).	314
4.6. Incised and punctated decoration on Napatan jars and bowls. White infill survives in some of the holes (1204y and similar). Slip-painted decoration (1081y) (scale 1:2).	315
4.7. Coarser variations (1054y and 1167y) of slip decoration; stamped (1178y, 1179y, 1263y, 1277y and 1285y) and painted decoration on Meroitic cups (1270-1273y), bowls or flagons (1162y and 1279y) and jars (1289-1292y) (scale 1:2).	316
4.8. Painted decoration on Meroitic period jars (scale 1:2).	317
4.9. Painted decoration on Meroitic period jars, continued. 1276y and 1286y are at scale 1:4, others at 1:2.	318

5. The Graffiti and Pot Marks

5.1. Symbols and/or 'Greek' (?) letters (scale 1:2).	335
5.2. Symbols and/or Greek letters, continued (scale 1:2).	336
5.3. Symbols and/or Greek letters, continued (scale 1:2).	337
5.4. Napatan and Meroitic graffiti, symbols/letters (scale 1:2).	338
5.5. More incised symbols; <i>tituli picti</i> (230g and 234g); potter's marks, made pre- and post-firing (scale 1:2).	339
5.6. Graffiti chiefly on Napatan amphorae, in particular the grid motif (scale 1:2).	340
5.7. Further variations of the grid motif on Napatan amphorae (scale 1:2).	341
5.8. Grid motifs and developments thereof (scale 1:2).	342
5.9. Random scribbles (?) and rectangular motifs (scale 1:2).	343

5.10. Particularly fragmentary marks (scale 1:2).	344
5.11. Various birds and a horse (?); composite graffiti scenes (scale 1:2).	345
6. The Napatan amphorae from Building F1	
6.1. Building F1 – location of the rooms.	353
6.2. Amphorae forms from Building F1 (scale 1:8).	355
6.3. Amphorae forms from Building F1, continued (scale 1:8).	356
7. The pottery finds from Site R18	
7.1. Ceramic grave goods from graves (GD3)11, 20, 38 and 45 (scale 1:6).	371
7.2. Ceramic grave goods from graves (GD3)63 and 98; (HA1)1075 and a complete feeding cup from the descendency of grave (HA1)1084 (scale 1:6).	372
7.3. Ceramic grave goods from graves (HA2)67/229, 116, 119; (JE3)115, (JF2)2 and 79 (scale 1:6).	373
7.4. Ceramic grave goods from graves (JG1)12; (JG2)2, 150 and 244; (JH3)21 and 39 (scale 1:6).	374
7.5. Ceramic grave goods from graves (JH3)43, 116; (JI4)1 (scale 1:6).	375
7.6. Dishes, bowls, incense burners, beakers and a spouted bowl, found in the vicinity of a grave, but that do not definitely belong to is grave goods (scale 1:6).	376
7.7. Jar and basin forms, found in the vicinity of a grave, but that do not definitely belong to it as grave goods (scale 1:6).	377
8. Miscellaneous Features	
8.1. Volumes. All vessels to scale 1:4.	385

List of Plates

3. The Forms

3.1.1. Napatan amphorae.	35
3.2.1. Imported amphorae and a red-slipped Napatan jar with a beaded rim.	57
3.2.2. Meroitic beer jars.	58
3.2.3. Meroitic jars	59
3.2.4. The painted body of the <i>krater</i> , and various narrow-necked Meroitic jars.	60
3.2.5. A jug, a pilgrim bottle, a bottle and an (imported) <i>unguentarium</i> .	61
3.3.1. Jar 4552x.	67
3.4.1. Examples of large storage jars. Note especially the presence of two holes near the base of 2792x and the lid-seating on 4650x.	97
3.5.1. Examples of wheel-made jars.	102
3.6.1. Black-burnished jars and a selection of cups.	128
3.6.2. A selection of Meroitic bowls and a deep Napatan bowl and beaker, both red-slipped.	129
3.7.1. A selection of RBRIE jars, bowls and cups.	170
3.7.2. Miscellaneous cooking pots, note thickening of the base in some	171
3.7.3. A wheel-made cooking pot, a basin and a medium-sized storage jar.	172
3.8.1. Examples of ware 910 (3225x), CRR (3244x & 4656x); vessels with oval rims and appliqué scars; a coarseware dish.	214
3.9.1. <i>Quseiba</i> at el-Khandaq.	229
3.9.2. Interior of a <i>doka</i> (3828x), bread-platters (2019x & 3074x), a crocodile-rimmed basin, a spouted vessel and varieties of lid knobs/handles (2717x & 4734x).	243
3.10.1. Dishes found in Building A2, used to mix (or apply) pigments. From left to right: (AD5)126, 2109x, (AD5)69, body sherd, (AD5)28, and 2107x (3.10.6).	251
3.10.2. Beakers and offering dishes.	259
3.11.1. Modern 'braziers', similar in design to the ancient ones.	270
3.11.2. 2952x (3.11.10) next to a modern lid of an aluminium cooking pot.	272
3.11.3. A selection of the best preserved incense burners/braziers.	284
3.11.4. Handmade incense burners and braziers used for heating food (?).	285
3.11.5. Pot-stands, spouted cups, a miniature pot, an unfired bowl and a lid with a tall handle.	286
3.12.1. Miscellaneous handles of wheel-made jugs or amphorae	294

4. Decoration on the ceramic vessels at Kawa

4.1. 3831x, 1167y (FO6)37 Finger marks on interior, the result of the manufacturing process.	307
4.2. A selection of decoration types, including 1057y (not drawn).	319
4.3. Miscellaneous painted motifs, including 1146y, 1148y, 1261y and the Aegean import 1296y (not drawn).	320

5. The Graffiti and Pot Marks

5.1. Detail of 1287g on bowl 4834x. Note faint outline of a bird's head to the right of the 'H', and the less fluid lines of the butterfly/snail.	334
5.2. Selected photos of the graffiti, including 216g (not drawn).	346

6. The Napatan amphorae from Building F1

6.1. Red circular areas on the bases of amphorae 4662x (l) and 3284x (r).	351
6.2. Notches cut in the rim for string placed under the mud stopper.	352
6.3. Reconstructed oil stained amphora 4676x from Building F1.	353
6.4. RBRIE cups reused as lamps, principally found in Building F1.	353
6.5. Some of the amphorae from Building F1 (cf. Figure 6.2). Note also (12) 4657x, (13) 4658x, (21) 4667x and (37) 4685x, for which there are no drawings.	357
6.6. Some of the amphorae from Building F1 (cf. Figure 6.3).	358

7. The pottery finds from Site R18

7.1. Jar and cup set, R18 grave (KE5)8.	362
7.2. Ceramic grave goods from graves (GD3)11, 20, 38 and 98.	378

7.3. Ceramic grave goods from graves (GD3)45 and (HA1)1075.	379
7.4. Ceramic grave goods from graves JH3)39 and 116.	380
8. Miscellaneous Features	
8.1. 2770x (AB5)41, a partly fired bowl.	382
8.2. Hanging pot with pre-firing holes and rope wear marks (3.4.6).	383
10. Concluding remarks	
10.1. Hanging pots in a modern <i>qahwa</i> .	390

Acknowledgements

Many thanks are due to SARS, the British Museum and the Qatar-Sudan Archaeological Project (QSAP) for funding the work on recording the pottery in the field and writing the present report.

Help with drawing in the field, particularly of the larger vessels, was provided by Sandra Rowntree, †Ross Thomas (who also digitised some field drawings and recorded pottery in the field during and following the 2008-09 and 2009-10 seasons), Elisa Vecchi, Alain Sanz Pascal and Derek Welsby. All other drawings are by the author, as are the subsequent inking, digitisation and layout. Many

thanks also to Eliza Dougherty for restoring some of the fragmentary forms, in particular the challenging brazier 2645x. Finally, a collective thanks to all those team members who painstakingly marked the pots in the days before Sharpie pens.

In the course of writing up additional thanks are due to Loretta Kilroe, Saskia Büchner-Matthews, Vincent Francigny, †Roberta Tomber and Derek Welsby.

Finally, many thanks to Patricia Spencer for painstakingly copy-editing the manuscript. Responsibility for any remaining errors rests with the author.

1. Introduction

The pottery published in this volume was excavated and recorded between 1997 and 2018. During the first seasons only diagnostic sherds (rims, bases, handles, decorated pottery and unusual fabrics) were recorded, ignoring the non-diagnostic body sherds for the sake of keeping up with the quantity of pottery excavated. This concerns only the pottery from Area B and part of Area A. From 2001 onwards all pottery, including plain body sherds, was included in the recording. Area Z was excavated just before work at Kawa was suspended while the SARS Amri to Kirbekan survey in the region of the Fourth Cataract was undertaken (2002-2007), and somehow part of the pottery from (ZH5) was drawn but not fully recorded. This unfortunately skews the data we have for Areas A, B and Z, but nonetheless the rim vessel equivalents (RVEs) can still be compared.

The types of vessel found at Kawa range from locally made cooking pots and other coarsewares, to imported amphorae from Egypt, the Levant, Italy and possibly also Greece and Asia Minor (but only making up a very small percentage of the total pottery found). The full gamut of forms is present, from cups, bowls, beakers to cylindrical bread ovens, storage bins and lids, *doka*, bread platters, cooking pots with thickened bases, basins and closed and open-mouthed jars, incense burners and bread cones.

While a large proportion of the published pottery that has been consulted for datable parallels comes from cemeteries, we have at Kawa a wide range of locations, from domestic (Areas B, C and Z), a shrine and ancillary buildings (Area A), two kilns (Areas FR, FS and FT), a magazine probably with high status accommodation on its upper floor (Building F1), a street (FZ2) and a gateway (T), to funerary (Site R18, *passim*). This will assist in understanding the choice of grave goods, making it possible to rule out, for example, that the offerings in the graves were special forms or wares for funerary use only. It will hopefully also help to expand our knowledge of Napatan domestic archaeology, food preparation and diet, as well as giving an increased understanding of the volume of trade (or lack thereof).

The pottery finds from the site are presented here not by area but according to type of vessel. The basic information relating to each form (see Figures in Sections 3.1-3.12 and the related Plates), decoration type (Figures 4.1-10, Plates 4.1-2) and graffiti (Figures 5.1-5.10, Plate 5.1) is presented in tabular form (Tables 3.1-12, 4.1 & 5.1). All forms are illustrated with a drawing, except in section 1, where several of the Napatan amphorae from Building F1 are essentially identical and have thus been amalgamated (see Table 3.1.1); the complete forms are, however, shown in Figures 6.2 and 6.3, where the majority of the amphorae found in Building F1 are illustrated.

The tables (3.1-3.12) contain information on what contexts a particular form occurs in, what fabrics it is made from, what graffiti, decoration and /or surface treatments were applied to it, its diameter range and the rim percentage, and finally whether it is handmade or wheel-made. Where one characteristic dominates significantly over the other(s) it has been marked in **bold**. A similar range of information

is given in Tables 4.1 and 5.1 for decoration and graffiti. The fabrics are discussed below in Chapter 2.

In total 211,088 sherds or complete pots were found and processed, weighing 5,037 kg. Out of this total *c.* 2,600 forms, 200 types of decoration and 210 graffiti or pot marks were recorded and drawn. The total number of vessels consists of a minimum of 3,686 rims (based on the total Rim Vessel Equivalent [RVE] percentage), 1,637 bases (base percentage¹) and 185 handles not attached to a rim or complete pot. The RVE only tells us about the minimum number of vessels – there are in reality far more, as only looking at the total percentage would assume that they all join, which is not the case. Soil samples were collected from many of the complete pots, and the results of the analysis will be published in the future.

Discussions follow of the characteristics of the assemblages in each area, and of the dating where this is known. In some instances it is possible to match the chronology between areas. In general, only broad chronological changes can be noted, rather than small changes within shorter time periods – dealing with centuries rather than decades. A large number of very similar forms have been drawn, partly in the expectation that, as with the wheel-made wares in the Roman world, it might be possible to pinpoint changes to within a few decades. This now seems improbable for the Napatan and the early Meroitic centuries, as the bulk of the pottery is handmade and utilitarian in nature. Certain wheel-made forms are very distinctive, but were rarely noted in earlier or later contexts in a slightly modified form; it is more the case that certain types come into favour and then disappear altogether without any morphological change over their period of production. Another factor is that the areas excavated at Q3 have different functions, as noted above – domestic, religious, industrial or public areas. While each trench explored at Kawa attempted to reach the natural, this was not always possible, given the depth of thick deposits of wind-blown sand, a characteristic of the site; the complexity of the occupation also often combined to make this impossible. The absence of New Kingdom ceramics in the present corpus is no doubt due to this, especially in area (TG5), where, despite its central location, the lowest levels still only yielded forms that appear to be Napatan.

Attentive readers of the report will note that a number of forms occur that were manufactured either by hand or on the wheel. This is *per se* not problematic (these are relatively basic forms, of course) and is a phenomenon that has been noted far afield in different periods and locations, where a potter would make the same form either by hand or on the wheel (Amorós Ruiz and Gutiérrez Lloret 2020, 103, with further references).

¹ Base vessel equivalent cannot, however, be used to establish a minimum vessel equivalent (although the diameter and percentage thereof were recorded), as said bases could belong to the same vessel as the rims, thus falsely doubling the minimum vessel count. Every attempt was made to join bases to rims while recording the material, but the fragmentary nature of the material excludes the possibility that all joins were found.

2. Discussion of the fabrics found in the town and cemetery

During the first season of excavation at Kawa, the type series of fabrics built up in the course of the Northern Dongola Reach Survey (NDRS) were used where possible, but new fabrics were soon introduced.¹ For example, Fabric 1, a medium coarse Nile silt, was omnipresent at Kerma period sites, but the ubiquitous Nile silt fabric in the Napatan period (Fabric 92) has a slightly different look. New imported fabrics were noted, and Nile silt fabrics that again look different because of different clay preparation, firing techniques or temperatures also required new numbers. Throughout the seasons the 'old' fabric reference collection continued to be consulted while the new fabric types grew in number.

A total of 142 fabrics have been recorded at Kawa and its cemetery (Fabrics 51 and 64 from the earlier NDRS corpus are absent); most of these are Nile silts, the distinction between them sometimes possibly merely due to variations in the firing temperature, whereas other apparent disparities between them may be due to manufacture in different periods over time (different sources of inclusions, for example). Fifty-three of these have been identified (or in most cases merely described)² since the beginning of the excavations.

Analysis of the data relating to the proportions of different fabrics at Kawa and its Kushite period cemetery reveals that, not surprisingly, Nile Silt or Nile Clay fabrics are by far the most common, especially in the Napatan period. Whether these were produced at Kawa or brought in from elsewhere in Sudan or Egypt is not clear at this point in time. Certainly the large quantities of handmade bowls, cooking pots and cups in Fabrics 92 and 110 are most likely to have been made at Kawa, and the same is the case when it comes to bread cones (Fabric 25), *doka* and bread ovens (Fabric 71). The offering dishes discussed in section 10, often somewhat sloppily made on the wheel, were probably manufactured locally, suggesting that some form of wheel-made ceramic industry was present. However, the better-made wheel-made bowls and basins, still in Nile Silt (e.g. Fabrics 65, 67, 69 and 94), often with a white slip covering the interior as well as the rim and the upper body, or with a red slip on both surfaces, may have been produced elsewhere (this impression is partly influenced by the fact that they are less common at Kawa than handmade wares). We do, however, have the evidence of form 2070x, which is only partially fired, suggesting that some of the 'quality' wares were also produced at Kawa.

The characteristic Napatan amphorae (see section 3.1) appear in a range of fabrics; an interesting fact, as apart from some variation in the wall thickness, they are all of the same basic form (with minor variations and in two or three different sizes). These are Fabrics 18, 23, 102, 103, 113 and 128 for the indubitably imported vessels, and Fabrics 93, 98 and 130 for the possibly more locally made examples.

Fabric 87 is another very characteristic amphora fabric, belonging to Levantine amphorae, whose presence at Kawa dates (from the forms) to the 25th Dynasty. Altogether

barely enough sherds have been found to make up one single vessel, but as sherds have been found in all areas except for Area Z, clearly several vessels had found their way to Kawa. Only a few sherds are present in each of the trenches in Areas C and F and in the superstructures of three grave monuments in R18. The more significant occurrences (although we are still talking of very small numbers) are in Areas A, B and grid square (TG5).

In the Meroitic period the coarse cooking wares are still made in the same Nile silt fabrics that were popular in the previous period, but we have the addition of a handful of examples in very quartz-rich fabrics, such as Fabrics 58, 59 and 131. The black burnished jars with impressed decoration (4335x and 4336x) are fairly rare both in the town and in the cemetery and are made with the same type of fabrics as their distant ancestors in the C-Group, i.e. fabrics 1, 8 and 11.

A number of marls make a discreet appearance across the site; some, such as Fabrics 18, 23, 102, 103 feature in Napatan contexts, while Fabrics 13, 29, 53, 130 and 142 are more likely to be of Meroitic date.

Fabric 26 has a fine kaolin matrix with no visible inclusions, and is principally used in the manufacture of the characteristic painted Meroitic cups (best illustrated by 4785x, 3.6.2), so is a good indicator of this period. The fabric is represented by one small body sherd only in one of the upper levels of Building A2, Rooms II and V-VII [(AD5)7]; in Building B12 (topsoil; (BD2)71; (BE2)10, 11; (BE3)1; (BF2)1, 31; (BF3)7) but not at all in Area F nor in Z; only a handful of examples occur in Areas C [(CE4)1, 71; (CF4)1, 107, 111) and T [(TG5)24, 27, 104, 120] and is marginally more prolific in the cemetery. It is the equivalent of Sai fabric SAI 005, and Sedeinga fabric SED 009 (David 2018, 483, fig. 5).

Manufacturing techniques

Most of the pottery has been recorded either as hand or wheel-made, with the 'slow wheel' being indicated when the pots are hastily and crudely made, such as the offering dishes. Others are clearly coil-built, such as some of the basins and storage containers. Mould-made vessels are restricted to several of the bases of the large beakers (3.10.1-3) and the few wheel-made red-rimmed bowls or cups found in graves in grid square (GD3) in the cemetery.

The quantity and proportional presence of the fabrics

We must remember that the statistical relationship between the fabrics is distorted by the fact that some vessels are much heavier than others (Fabric 71, bread oven cylinder vs. Fabric 26, Meroitic fine ware cup, for example) and that in some instances a complete pot is the only evidence for a particular fabric, 142 for example, weighing a couple of kilos. Furthermore, one sherd of a fabric still proves the

¹ Fabrics number 1-90 were originally published in Welsby Sjöström 2001, 230-38).

² That is to say, not related to an 'established' fabric, such as Marl A, etc.

presence of a whole vessel at the site, just as much as a complete vessel. The comparative weights give us an idea of which vessels, or in this case fabrics, were present in greater quantities. The recorded sherd count, however, helps to give a more balanced understanding of the quantities.

In order to help visualise the relative quantity of pottery represented by each fabric, in Table 2.1 the fabrics have been colour-coded according to their frequency/quantity. The four groups, according to their weight, are:

- red – more than 10kg
- blue – between 1kg and 9.99kg
- green – up to 1kg
- yellow – the rarest, less than 100gm

Overall (Q3 and R18), out of a total of 142 fabrics, the most common (26 fabrics, each in total weighing more than 10kg), make up 80.5% of the total recorded.

The blue category comprises 45 fabrics and constitutes 3% of the total.

The green category comprises 56 fabrics and 0.5% of the total.

The rarest fabrics (Fabric 15, yellow) make up only 0.01%.

Twenty-two fabrics, within the yellow and green groups, are only represented by body sherds with no diagnostic features (Fabrics 28, 36, 36, 37, 41, 43, 44, 47, 55, 62, 73, 101, 109, 120, 123, 127, 134, 135, 137, 138, 143 and 144).

In a number of instances, multiple fabric types were assigned to large quantities of body sherds from large contexts, always variations of Nile silt fabrics, especially Fabrics 67, 92, 94 and 110. This was done in order to allow enough time to record the diagnostic sherds adequately, and leaves 15% of the total only identified as a Nile silt fabric.

Finally, no fabric number was assigned to 0.7% of the total assemblage.

Explanations to the Fabric Descriptions and Table 2.1

The fabrics were studied by hand lens (x 4 magnification). In some cases the context in which the fabric was first noted is listed.

Hardness is defined as:

Soft – scratches easily with a fingernail. Muted sound when dropped on hard surface.

Medium hard – possible to scratch with fingernail. Most silt wares would fall into this category.

Hard – difficult or impossible to mark with fingernail, makes metallic sound when dropped on hard surface. A very hard-wearing fabric.

In the tables throughout this report the fabric numbers may be accompanied by a letter, which stands for the following:

C – Coarse (coarser than the fabric sample – more inclusions, coarser or larger inclusions, poorly sorted, but still within the parameters of the type specimen).

F – Fine (finer than the type specimen, less inclusions, well sorted inclusions and altogether neater in appearance)

L – Extra lime.

OX – oxidised, i.e orange in colour, when the norm for a particular fabric would not be.

Fabric descriptions



FAB 1 Nile silt – Brown matrix with common medium-sized quartz grains (0.5-1.5mm), sub-rounded and rounded, stray burn-out holes. Sparse lime, 0.2mm average. Medium coarse pottery. Medium hard. Common in all periods.



FAB 2 Nile silt – Hard, sub-rounded quartz grains (transparent), some straw. Generally appears harder fired than FAB 1. Some sub-angular white lime inclusions, which stand out and distinguish this fabric from FAB 1.



FAB 3 Nile silt – Sparse clear quartz sand (sub-rounded), white specks, in a 'striated' matrix. Some straw, but not common, also burn-out holes. Medium hard, usually associated with cooking pots with basket impression 5y. The few sherds found at the town and in the cemetery are most likely residual actual *Kerma Classique*, with the possible exception of form 2990x, whose fabric may just have happened to have been prepared in the same way as the Kerma period vessels.



FAB 4 Nile silt – Well fired, some sub-angular lime, sparse sub-rounded transparent quartz sand and sparse grey-black grains, 0.5mm. Explosion chambers (<1mm). Occasional sub-angular, yellowish lime, 0.5-1mm. Hard. NB occurs both as handmade and wheel-made.



FAB 5 Frequent, angular quartz sand, elongated or squared, ranging in size between 0.5-1.5mm. Mostly evenly sorted, but with some unusually large grains. Grey-brown to pinkish colour. A Neolithic fabric, with little or no organic inclusions; the handful of occurrences were all found in the cemetery and may originally have come from destroyed Neolithic graves. Hard.



FAB 6 Nile silt – Most common fabric by far. Reduced, black matrix with very fine inclusions. A few specks of lime, occasionally larger sub-angular lime particles (up to 1mm), but very infrequent, plus some very sparse clear aeolian sand grains, explosion chambers/ air holes, 0.5mm average, but very sparse. Some rounded, dark grey inclusions, probably badly mixed clay? Generally a fine ware fabric for the black-topped Kerma period burnished bowls. Medium hard. Some variation in the coarseness of the fabric was present.



FAB 7 Nile silt – Essentially the same as FAB 6, but finer (this is superficially due to the wall thickness rather than because of the number and size of any inclusions). Kerma beakers are always made with this fabric. Medium hard.



FAB 8 Nile silt – Similar to FAB 1, sand inclusions in a brownish fabric, but better fired and less organic inclusions. Some mica. Principally occurs in coarseware bowls of the Kerma period.



FAB 9 Coarse fabric, fired an uneven bright orange and buff. Ill-sorted inclusions, some straw, common sub-rounded quartz sand and lime, average size 0.5mm, and some unidentified grey particles. Medium hard. Used in a variety of vessels, cooking pots, storage vessels and bowls, both handmade and wheel-made.



FAB 10 Nile silt – Looks similar to FAB 1, but more brittle, and with more explosion chambers. One of the examples (J22.2) has a lot of sand, sparse sub-rounded clear brown quartz, as well as sub-angular lime and milky quartz, medium common, about 0.3mm in size. Other example has more lime, resembles FAB 2.



FAB 11 Nile silt – Similar to FAB 10, but more straw holes as well as explosion chambers. Fairly hard, coarseware. Matrix reduced, black to brown, with some specks of indeterminate nature, brownish, sub-rounded sparse lime? Medium hard.



FAB 12 Nile silt – Catch-all coarseware fabric type, with large lime and grey quartz inclusions, about 1mm in size, visible on eroded surface only, straw, explosion chambers, oxidized exterior, reduced interior. Occurs in all periods. Hard.



FAB 13 Marl – Pink-grey wheel-made fabric, with sparse grog, lime (0.2-0.7mm) and some grey specks – possibly reduced grog? Medium hard. Also some 0.2mm grey to milky clear sub-angular quartz sand, poorly sorted, not constant throughout sherd, and sparse specks of mica. An import, most likely from Egypt.



FAB 14 Marl? – Finer matrix, but still a coarseware: mica, lime and sub-angular quartz (white-grey) some explosion chambers. Pink/red grog. Not very well mixed, large amorphous lumps of badly levigated clay? Medium hard, commonly wheel-made.



FAB 15 Marl E? – White/pink/grey matrix, white ‘dry bread’ texture, with straw and sparse rounded quartz grains, about 0.5mm in size. Sparse flecks of white lime. Air holes, some straw still *in situ*. Similar striated look to FAB 3, but pale fabric, medium hardness.



FAB 16 Marl? – Wheel-made, pink and grey. Common lime particles, between 0.2-0.1mm, sub-angular, red and grey grog. Sparse straw. Coarser than FAB 13. Medium hard.



FAB 17 Coarse jug fabric, common sub-rounded sand and lime particles, some partially exploded. Orange with interior reduced. Sparse, occasional oversized angular lime particles, 2mm in size. Medium hard.



FAB 18 Marl A3? – White to pale green fabric with sub-rounded fine sand inclusions, about 2mm in size. Some sub-angular sand, black and multi coloured. Wheel-made, Egyptian import. Related to FAB 23? Medium hard.



FAB 19 Nile silt – Similar to FAB 1, mostly straw and some sand. Soft fabric. Sparse mica.



FAB 20 Nile silt – Medium soft fabric, with a lot of sub-angular sand, fairly friable and coarse. White lime and sand, not much straw if any. Other grey inclusions same colour as matrix, unidentified, grog or unlevigated clay? This coarse fabric is similar to a Post-Medieval coarseware fabric, but it is not suggested here that the few sherds at Kawa are this late in date, but rather a similar fabric fired in a similar way.

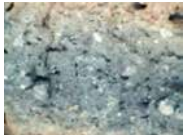

FAB 21 Nile silt – Coarser version of FAB 20. Large grey and pink grog, slightly smaller inclusions of lime, average size 1-1.5mm. Air holes common. Harder fired than FAB 20, medium hard. Bears the same similarity to a Post-Medieval fabric as does FAB 20.



FAB 22 Marl? – Dusty pink to greyish coloured matrix. Quite fine in appearance, despite sparse, unidentified sub-rounded grey inclusions of up to 1mm, and sub-angular, ill-sorted lime, 0.2-0.6mm. Also sparse flecks of mica. Most likely an Egyptian import. Uneven break, medium hard.



FAB 23 Marl A2? – Similar to FAB 22, but has a high proportion of sub-rounded quartz sand, some sub-angular, average 0.2mm, although it is not visible to the naked eye. Clear and white, all set in a fleshy-pink matrix. Lime speckles in orange-pink matrix. Occasionally FAB 18, depending on firing condition, looks like FAB 23. Most likely an Egyptian import. Hard to medium depending on degree of wind patination.



FAB 24 Marl D? – Coarser version of FAB 22, with much lime, very noticeable to naked eye, some exploded (average size 0.2mm), a little grog, well sorted. Sparse sub-rounded clear quartz grains, average size 0.5mm. Hard, well fired.



FAB 25 Nile silt – ‘Brick-like’ fabric, orange matrix and surface, moderately friable with a little sub-rounded clear sand and straw. Used for bowls and especially bread moulds, *inter alia*.



FAB 26 Marl – Fine, buff-pink ware with sparse red grog inclusions, about 0.2mm. Hackly, longitudinal way of breaking. Unidentified black sub-angular (volcanic?) inclusions, 0.5mm. Hard. Meroitic.



FAB 27 Marl? – Blotchy yellow on pink appearance of surface due to partially eroded white slip? Pink surface, interior reduced. Wheel-made. Common sub-angular specks of lime, c. 0.1mm, occasionally 1mm. Sub-angular quartz and sparse grey grog, <0.5mm. Hard.



FAB 28 Marl? – Orangey-brown matrix, with poorly sorted sub-angular ironstone (or pure clay?) inclusions 0.5-2mm. Also poorly sorted sub-angular white lime, 0.2-1mm. Some sub-rounded sand too. Very hard. No diagnostics.



FAB 29 Similar to FAB 22, but with specks of sub-rounded lime (0.2-0.5mm) and a little grog (0.4mm). Some explosion chambers and some vesicles, plus sand in small proportion. Wheel-made, quite hard and smooth, ill sorted. Matrix grey to buff. There is red slip on the exterior of the sample, could be Napatan or Meroitic? Hard.



FAB 30 Nile silt – Coarseware, brownish red matrix. Sparse lime, 0.3mm, and common black (charcoal?) inclusions, 0.5-0.8mm. Also air explosion chambers and sparse specks of mica. Hackly break, medium hard.



FAB 31 Marl – Yellow-pink-grey matrix. Common to sparse lime inclusions, 0.2-2mm, sparse grog, very red, 0.3mm and straw, also possibly grey grog. Sub-rounded sand. Frequent air holes. Colour of matrix extremely distinctive. Hard, quite fine and wheel-made. Parallel suggestions include identification as 'keg ware' from the Egyptian Western Oases, 25th-26th Dynasty, while another dating suggestion is Meroitic (B. Żurawski, pers. comm.).



FAB 32 Grey and pink matrix. Wheel-made, with tiny inclusions. Sparse lime, 0.2mm. Specks of mica. Even break, hard fired.



FAB 33 Marl – Pale brown-buff colour matrix, porous but with a badly-levigated look. Reasonably common, ill-sorted grey or milky sub-rounded quartz sand, averaging 0.5mm. Sparse lime, c. 0.3mm. Sparse red grog. Medium hard.

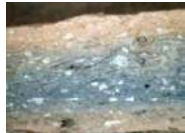

FAB 34 Quartz, both sub-rounded and sub-angular, and lime, as well as red grog, 0.5-1.5mm. White inclusions very noticeable in break. Common milky quartz and lime, both sub-rounded, ill-sorted, 0.1-1.5mm. Straw holes. Pinkish surface, exterior surface originally had red slip. Hard to medium hardness.



FAB 35 Marl? – Coarse fabric with common grey and white inclusions, grey grog(?) and lime respectively as well as some sub-angular grey-white quartz in elongated shapes. Brown matrix, hackly break. Grey range of inclusions most noticeable, on surfaces, as well as break. 0.2-1mm average size of all inclusions. Hard. No diagnostics.



FAB 36 Fine, grey brown fabric matrix virtually without inclusions. Very sparse sub-rounded lime, 0.5mm. Similar to FAB 32, except for colour of matrix. Even break, medium hard. No diagnostics



FAB 37 Marl – Dark pink matrix, with sparse dark red inclusions, possibly grog, 0.2-1.5mm, dusty look, even to conchoidal break. Fine, wheel-made, medium hard. No diagnostics.



FAB 38 Marl? – Sand, frequent sub-angular grey-white quartz (0.2-1mm) and rounded grog. Pink and grey matrix, coarseware, possibly wheel-made, but sample is very abraded. White speckled effect is very noticeable. Some very large inclusions, which have now dropped out. Ill-sorted. Few, if any, air holes.



FAB 39 Marl C – Coarse, jar type fabric, pink exterior, grey in core, with very large ‘ironstone’ inclusions (0.5-2mm), some grey and pebble-like. Red grog. Hackly break. Erosion makes inclusions stand out. Badly sorted, well-fired. In one instance at least, white slip on exterior. Possible connection with FAB 35, but inclusions are coarser. Hard.



FAB 40 Unusual, distinctive fabric, very soft and friable, fractures easily like schist. Powdery buff to pink appearance, with a little red grog. Hackly, highly irregular break. Sparse, sub-angular grey quartz. 0.5mm and sparse grog, sub-rounded. Sub-angular white lime. A softer, debased form of FAB 37? Similar to SJE ware IIIP, an Egyptian import used in jars, e.g., 12th Dynasty or later. (Säve-Söderbergh 1989, I, site 179, 111:01).



FAB 41 Marl – Similar to FAB 33, powdery brown-pink, with large (0.2-4mm) grey inclusions and sparse lime, and rare large rounded quartz (?) inclusions. Large vessel. More compact than FAB 33. Hackly break, some air holes. Hard. Probably a Egyptian import. No diagnostic sherds were found, only wheel-made jar sherds, with an exterior white wash.



FAB 42 Frequent to common sub-angular, clear and cloudy, quartz sand. Greyish matrix, sparse ill-sorted sub-angular lime, approximately 0.5mm. Absent or insignificant presence of vegetable temper. Hackly, uneven break. Crumbly look, but medium hardness.



FAB 43 Nile silt – Very similar to FAB 1 or FAB 8, common sub-rounded quartz sand, 0.5mm. Sparse, irregularly-shaped lime c. 0.5mm. The brown-black grey matrix has a mottled appearance like FAB 3. Hard. Very rare, and only occurs as a few cooking ware body sherds. No diagnostic sherds.



FAB 44 Nile silt – Handmade. Like FAB 3, but with sparse large (0.4-2mm) and small white-grey quartz and lime inclusions. Also some blood-red ironstone, more evenly sorted. Very much a salt-and-pepper effect. Exterior oxidized. Very uneven break. Clay not very well levigated, reminiscent of FAB 12, except for distinctive inclusions, and also much harder. No diagnostic sherds.



FAB 45 Nile silt – Very similar to FAB 20. Porous appearance due to much sparse to common, sub-rounded, clear quartz grains that have fallen out of break, air holes (genuine air holes, not lime-explosion chambers) and a little, well sorted lime. Brown grey matrix. Hackly break. Medium hard and coarse. Mainly handmade vessels, late Napatan to Meroitic.



FAB 46 Marl? – Generically wheel-made. Orange coloured matrix with some ironstone fragments, yellow unidentified inclusions (lime?), and some black specks (0.2-0.5mm). Similar to FAB 25. Medium hard, slightly porous, well mixed, but with the odd ill-sorted inclusions. Medium hackly, uneven break. Sparse clear sub-angular quartz. 0.5mm, General aspect orange background with dark pointillistic effect. Could be the fabric used for Aswani amphorae, 1st- 4th century AD??



FAB 47 Marl? – Pale, buff coloured matrix, with common and noticeable ill-sorted sub-angular and sub-rounded but irregularly shaped white quartz inclusions. A few black, sub-rounded inclusions also. Similar to FAB 44 apart from matrix colour. Similar to FAB 41, apart from colour of inclusions. Frequent sub-rounded clear quartz sand. Sparse grog, 0.5mm. Uneven break. Hard. No diagnostic sherds.



FAB 48 Nile silt – Much like FAB 19 or FAB 1, but more like FAB 19 in that it contains straw. Resembles FAB 118 as well. The grey quartz-like inclusions of irregular shape, average 0.2mm are distinctive. Fairly hard and rough, though used for relatively thin-walled pot. Orange red surfaces. Very uneven break. Medium hardness. Porous look, sample is quite eroded. White lime inclusions, 0.5mm, sub-rounded, sparse, but notable on surface.



FAB 49 Marl – Orange fine ware, with some small lime explosion chambers, small flecks of ironstone or red grog – fine, homogenous appearance – not unlike FAB 22 or 23, but with much less lime. Faintly conchoidal break. Occasionally grog up to 1mm, colour buff to pink/orange. An amount of ill-sorted sand, and some sparse dark red/purple inclusions, about 0.5mm. Probably usually wheel-made, but samples are very wind-eroded. Hard.



FAB 50 Similar to FAB 1, unlike fabrics FAB 19 and FAB 48 in that it has little or no straw and a good amount of sub-angular, ill sorted quartzite sand; grey brown matrix. Very sparkly – mica is common and noticeable on exterior, interior and break, which is uneven. Coarseware. Medium hard.



FAB 52 Marl – Light brown matrix, a light brown toffee colour, quite compact with some transparent quartz sand, some sub-angular grey-white quartz and black specks. Inclusions common and well sorted, 0.2-0.5mm. Fairly even, slightly conchoidal break. Wheel-made ware with slip, hard. Meroitic.



FAB 53 Marl – Light orange/brown matrix, with a high proportion of multi-coloured sub-angular inclusions, <0.5mm. Well-sorted, particularly red and black. Wheel-made. Well-fired, very hard, even break. Could be the same fabric as that used for Aswani amphorae of the 1st - 4th century AD?



FAB 54 Friable, 'glittery' (especially noticeable on exterior surface) fabric, with mica and flaky quartz (sub-rounded, about 0.5mm), sub-angular lime inclusions. Easy to break, medium hard. Pink-grey coloured matrix. Uneven break. Very high proportion of inclusions to matrix. Coarseware.



FAB 55 Marl – Brown/buff matrix with sub-rounded transparent quartz sand, approximately 1%. Well-sorted brown sub-angular inclusions, approximately 10%. Friable. Uneven break. Striated appearance. Frequent brown and black inclusions very noticeable. Sparse sub-rounded white lime. Medium soft. No diagnostics.



FAB 56 Bright red fabric. Presumably high iron content in the clay. Also contains straw, 1-2%, sub-rounded clear quartz sand, 1-2% and a sparse sub-angular lime, approximately 1mm in size. Reasonably well-sorted. Coarseware at least in first instance of encountering the fabric, with red exterior slip. Golden specks of mica visible on interior. Medium to hard, uneven break.



FAB 57 Contains a large number of inclusions, not very well-sorted, sub-rounded lime, grey sub-rounded inclusions of varying size, 4% white and yellow inclusions, both lime? Also some rust coloured particles, <1%. Very hard fabric.



FAB 58 Nile silt – Medium soft brown fabric, coarseware. Similar to FAB 1, but with large, sub-angular clear crystals *c.* 1mm in size, quite a prominent feature. Core brown-grey-brown with some sub-rounded quartz sand. Well-sorted inclusions. The clay has a crumbly, sandy (silty) look, similar to FAB 1. Gold mica sparse but noticeable throughout. Sparse vegetable temper. Uneven to hackly break. Rather brittle.



FAB 59 Similar fabric to FAB 1, medium hard, with notable sparse opaque sub-rounded quartz 0.5mm, and angular white quartz inclusions evenly distributed throughout the matrix. Inclusions approximately 1mm in size, evenly sorted for size. First found used in a conical beaker. Black blotches in matrix, unclear what causes them. Some sparse mica also visible, break is uneven break. Meroitic handmade wares with impressed decoration, but also possibly Neolithic.



FAB 60 Fabric like FAB 25, red/orange matrix, coarse, but with frequent white lime inclusions, sub-angular and rather soft. Irregular in size, either as blobs or as slim specks. Some sub-angular quartz sand, not as common as the white lime. Hard-fired, hackly break. Rare at Kawa, most likely an import.



FAB 61 Red matrix similar colour to FAB 56, but finer clay with some straw, air explosion chambers. Sub-rounded and angular lime particles <0.5mm, of medium frequency. Sub-rounded black particles 1% - sparse. Bright red with purple tinge. Red slip commonly applied on exterior. Hard, fairly even break.



FAB 62 Marl – White buff/clay with frequent black inclusions, sub-rounded milky quartz sand ranging in colour from clear through brown to black. Well-sorted and frequent, mostly <0.5mm. Imported jar fabric? Wheel-made. Uneven break, hard.



FAB 63 Nile silt – Similar to FAB 11, but with common sand inclusions – sub-angular clear quartz, *c.* 0.1mm. What shows up on the surface (not always present) are yellowish lime inclusions of sub-angular shape, 1-2mm in size. Fabric reduced, reddish (oxidized) surface. Some vegetable temper. The forms it occurs in (both hand and wheel-made) suggests a Napatan date? Medium hard coarseware, uneven break.



FAB 65 Nile silt. Fine jar ware – similar to FAB 6 but with white, sub-angular, lime inclusions and oxidized exterior (specks and thin elongated particles); some air holes. Some sub-rounded sand grains, but sparse. Smooth, even surface. Medium hardness, even break. Fairly well sorted.



FAB 66 Matrix is orange to dark brown. Porous appearance, common but ill-sorted air holes. Noticeable lime inclusions, 0.1-1.5mm, sub-angular. Red grog and some sub-rounded clear quartz sand. Also some mica specks. Other whitish inclusions – elongated and narrow – shell? Vegetable temper. Sherds are wheel-made, belonging to amphora-type vessels that seem to have rounded bases with ‘navels’. Medium hard, hackly breaks.



FAB 67 This fabric occurs in all periods from *Kerma Ancien* to the Post-Medieval, but is a common wheel-made jar fabric in contexts throughout Kawa. Air holes, straw, mica, sparse but very noticeable lime (sub-angular, badly sorted, 0.1-1.5mm). Common sub-rounded clear quartz sand. Occasionally oxidised surfaces, reduced interior. A coarse, jar or amphora ware. Medium hard.



FAB 68 Wheel-made jar with frequent 0.1-2mm explosion chambers, covering the whole of the section. Overall mottled lime explosion chamber effect. A few larger lime particles approximately 1mm without explosion chambers. Smaller lime inclusions well sorted. Some sub-angular grog (sparse) 0.5mm. Black inclusions, angular and sparse, 0.5mm. Hackly break. Greenish/white slip/wash on sample. Hard.



FAB 69 Mica noticeably present on surface. Matrix light brown to light orange. Soft fabric, hackly breaks. Sparse sub-angular lime. Medium frequent sub-rounded quartz sand clear and black/dark grey. Occurs together with FAB 25, this is a common Napatan fabric. Wheel-made, used for coarse utility wares up to amphora size.



FAB 70 Nile silt – Medium fine ware with hackly break. Matrix dark grey. Inclusions: specks of fairly well sorted lime and common sub-angular sand, c. 0.4mm, varying whitish grey, some quartz. A few air holes of assorted sizes 0.5-2mm. Hard. Period uncertain.



FAB 71 Nile silt – Brick-like fabric, with common straw and bright orange to brown matrix. Sparse mica, some angular lime, but sparse. Coarsely mixed. Medium hard, hackly break. Possibly modern in some instances, but also used in storage bins at Kawa, Napatan period. Vessel wall about 25mm thick. Coarse handmade storage jar or cylindrical oven.



FAB 72 Nile silt – Basically FAB 6 with noticeable white lime inclusions. Reduced interior, medium hard.



FAB 73 Marl? – Similar to FAB 52, but matrix is pink. A possible firing variation, but really distinguished by red sub-rounded inclusions (grog or possibly ironstone?) 0.4-1mm, some of which are very irregular. Some sand – sub-rounded, and sparse sub-angular white inclusions, c. 0.3mm. Small medium common black inclusions 0.2mm average. Medium common air holes, 0.5-1mm. Sparse sub-angular white and yellow inclusions. Fabric generally has a hard, sandy (granular) look. Medium hard. Wheel-made, most likely Meroitic fabric, used for jars and ribbed amphorae (?); only body sherds recovered.



FAB 74 Core reduced. Break slightly hackly. Contains sparse specks of mica. Sub-rounded lime inclusions, 0.5-1.5mm, sparse but noticeable at first glance. Reasonably well sorted. A few air holes from burnt chaff. White slip on this example, medium hard. Wheel-made.



FAB 75 Similar to FAB 74. Buff to brown, reduced matrix, but contains sub-rounded clear quartz sand. Contains sparse flecks of lime, not noticeable without hand lens. Flecks of mica. Softer than FAB 74, break less hackly. Medium hard to soft. Wheel-made, Napatan?



FAB 76 Similar to FAB 61 and FAB 69, red/orange to brown matrix. Small inclusions of lime, 0.2-0.5mm, fairly well sorted. Sparse black sub-angular inclusions, 0.5mm. Sparse chaff. Mica very noticeable in section. Hard to medium hard, fairly even break. Wheel-made Napatan fabric.



FAB 77 Marl – Matrix varies in colour from buff to light orange. Sparse lime specks, barely noticeable to the naked eye. Occasional large air holes. Some specks of mica, and black sub-angular inclusions, sparse but noticeable due to contrast with clay colour. Occasional red inclusions sub-rounded, 0.5mm. Hard to medium, in places even break, in others conchoidal. Medium fine Napatan fabric, wheel-made.



FAB 78 Surface pink, interior reduced, grey. Very plentiful sub-angular lime inclusions, 0.1-1mm, some few with lime explosion chambers. A few air holes up to 2mm. Some larger inclusions 1.5mm grey and brown, sub-angular rather hard- possibly quartz. Alternately even or hackly break. Compact and dense fabric, rather hard. Meroitic period, imported amphora fabric, possibly belonging to a Camulodunum 182.

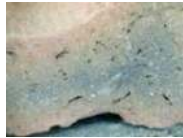

FAB 79 Similar to FAB 8, but with more air holes and evidence for chaff, fairly common and mostly burnt. Sparse sub-angular lime, 0.4mm, well sorted. Air holes most common, not a very dense fabric. Matrix orange coloured at edges, fading to a rich brown in the centre. Noticeable glimmer in section from mica. Medium hard, Meroitic period.



FAB 80 Bright orange colour, with possible pink core, depending on firing. Much sparkling mica. Similar to FAB 76. Sparse sub-angular lime approximately 0.5mm reasonably well sorted. Sparse, sub-rounded, clear quartz 0.5mm. A few sub-angular black inclusions, 0.5mm. Sparse vegetable temper. Medium hard. Jar fabric, mostly wheel-made.



FAB 81 Medium brown to reddish brown and grey reduced. Contains more sand and some lime than FAB 6. Sub-angular lime sparse, 0.5mm. Also specks of lime. Sub-rounded clear quartz sand, also sparse. Matrix had fine granular appearance. Occasional elongated air holes, some evidence of chaff. This particular sample had a thin burnish. Medium hard with uneven break. Mostly wheel-made fabric, period uncertain, but certainly Kushite.



FAB 82 Pale buff to reddish brown. Sparse mica. Matrix has fine grain, medium common specks of sub-angular lime, approximately 0.1-0.5mm. Sparse sub-rounded black inclusions. Badly mixed clay with striated effect, breaks in layers, though fairly hard. Fabric is wheel-made with two exceptions, of uncertain date but probably Napatan. Medium coarse to fine.



FAB 83 Similar to FAB 61 and FAB 76. Bright orange to light brown matrix. Mica sparkle in section. Common sub-angular black inclusions, 0.1mm. Sparse sub-angular lime, 0.5mm approximately. Clear and white sub-rounded quartz, some orange blobs of clay not well sorted – clay not well mixed? Jagged break, medium hard. Coarse jar fabric – wheel-made. Napatan?



FAB 84 Marl – Sparse sub-angular lime, 0.5mm, a few explosion chambers, 0.1-1mm. Air holes (sparse, 0.2mm) small, sparse lumps of badly-mixed clay, grey in colour as matrix in general. Medium hard. Grey fine ware, wheel-made, even break.



FAB 85 Marl – Very similar to FAB 52 in type of inclusions, but matrix entirely white! Well mixed. Fine sub-angular sand, 0.2mm. Sparse black, reddish inclusions. Hard, even slightly conchoidal break. Colour of matrix main distinguishing feature. Wheel-made fabric, related to FAB 26?.



FAB 86 Matrix buff coloured. Similar to FAB 69, but contains light red inclusions, 0.5-1.5mm, grog or unmixed clay; these are the most notable inclusion to the naked eye. Also sub-angular lime. Sub-rounded clear quartz sand and sparse angular black inclusions. Granular appearance and poorly sorted. Soft fabric, though break jagged. Medium coarse, probably of Napatan date.



FAB 87 Orange to buff colour, including notably frequent angular quartz sand, milky, black and grey average size 0.5mm, average sorting. Larger lumps or rounded quartz and possibly unmixed clay. Very hard fabric with conchoidal break. Typical of Levantine/Phoenician amphorae. Also occurs in two variants at Kawa, 87B 87C.



FAB 87B No diagnostic sherds.



FAB 87C



FAB 88 Marl. Coarser version of FAB 23 – also similar to FAB 16, but finer; buff pink colour, with white and red specks visible on surface, though the sample sherds are abraded on all surfaces. White sub-angular lime, 0.1-3mm, common, grog (red) varying shapes (slivers, sub-rounded particles) and sizes, 0.1-1mm, medium frequency. Air holes 0.1mm, common. Sparse unidentified grey-black inclusions, sub-angular. Wheel-made, possibly an Egyptian import in the Kushite period. Medium hard.

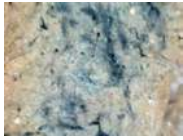

FAB 89 Related to FAB 1 and FAB 19, but has oxidized surfaces, with reduced core, at least on type sample. Inclusions of burnt straw and frequent, both sub-angular and sub-rounded clear quartz sand, 0.5-0.8mm. Sparse lime, sub-angular, 0.6-1.4mm. Uneven to hackly break. Medium hardness. Coarse jar fabric which occurs in many forms that often are made with FAB 110.



FAB 90 Brightly oxidized throughout, but this could be variable; packed with sub-angular and sub-rounded clear quartz sand, 0.3-1mm, similar to FAB 42 but definitely different fabric; surface does not have same matt gloss finish, the matrix has a more silty appearance, sherds are thicker and at least in this minute sample seem to belong to a coarse bowl, with nondescript surface treatment. Sparse lime flecks, sub-rounded, some with lime explosion chambers, 0.3mm. Medium hard.



FAB 91 Marl – (Building A3 /A4, Middle to New Kingdom??). Like a much coarser version of FAB 18. Pale yellow to beige matrix, with well-sorted black inclusions; some air holes. Black inclusions, 9mm thick common, rounded ironstone 3-0.5mm, rare rounded quartz 0.5mm sand and small dark grey sub-angular specks. Medium hard, moderately even break. Napatan or possibly Meroitic wheel-made jar fabric?



FAB 92 Nile silt – Similar to FAB 1, but more micaceous and the matrix is finer. Sparse but noticeable mica specks, c. 0.2mm, rare 8mm sub-rounded clear quartz inclusions and some chaff. Fired a medium brown colour, occasionally with a reduced core. Medium hard, medium rough break. Cooking wares and other coarsewares, principally of Napatan date, frequently wheel-made.

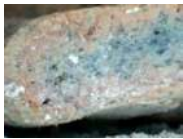

FAB 93 Wheel-made jar fabric, fires orange/pinkish red with occasional grey core. Sparse sub-angular lime, 0.5-1mm. Sub-rounded clear quartz 1mm, medium frequency, some straw (burnt away), medium frequency, common mica 0.1-0.2mm, rare grog 1.5mm. Medium hardness. Napatan wheel-made jar or amphora fabric.



FAB 94 Nile silt – Red brown with red orange core. Resembles FAB 80/69, but contains more lime than FAB 80, more straw than FAB 69. Medium coarse, straw common (some still surviving), specks and sparse sub-angular lime, 1-0.5mm. Brown to pink colour, specks of gold mica. Sparse or absent quartz. Napatan wheel-made generic fabric.



FAB 95 Nile silt – Fine Red brown matrix, with the core lighter than the surfaces, 8mm thick. Generally fine appearance, with few inclusions visible to the eye Some vesicles 1.4-1.3mm, rare sub-angular lime 0.5mm, No obvious organics, rare mica specks <0.1mm. Late Napatan? Good quality red burnished slip, wheel-made? First found and most common in Area B.



FAB 96 Marl – Pale yellow marl, 11mm thick. Similar to FAB 18, but with many more inclusions, and to FAB 62, but not as compact. Inclusions include red grog, badly sorted (5 x 3-1mm) Also black inclusions 0.5mm, granular pale yellow/greenish colour. Vesicles. Wheel-made jar fabric. Originally suspected of being a Phoenician amphora fabric, but not correct. Napatan/ early Meroitic wheel-made jar?



FAB 97 Nile silt – Coarser version of FAB94. Reddish brown to bright orange-red fabric with straw, 3-1mm; sub-angular and sub-rounded lime, 1.5-0.3mm; clear sub-quartz, 0.8-0.5mm (rounded). Mustard-coloured grog (?). Average thickness 8mm. Uncommon Napatan fabric.



FAB 98 Reddish-brown matrix with noticeable lime inclusions (as they stand out against the brown of the core), some mica. Granular appearance Sparse, if any, organic temper (straw) Sparse to common sub-angular lime, 1.8-0.2mm, some in long slivers. Clear quartz sand, sub-rounded, sparse, 0.5-0.2mm Air holes 0.1mm approximately, common but discreet; rare grog. A fairly porous fabric, especially used for Napatan amphorae. According to Ph. Ruffieux, a silt-marl mix (pers. comm).



FAB 99 Red slipped fineware, with no visible inclusions, fine pale brown/red matrix, reminiscent of a Late Roman slipped ware? Fine light red fabric with glossy red slip on both sides, 3.5mm thick Clean clay matrix with rare mica specks. Meroitic period, imported Terra Sigillata B dish? Only found in (CE4)1, (FT3)5 and (FO6)15.



FAB 100 Coarse jar, similar to 77 but with large amounts of straw, sparse lime and grog 0.2mm. Beige to brown matrix. Pale brown to beige Nile silt/ silt/marl mix? Poorly mixed. Distinctive organic temper and powdery texture. 10mm thick Common organic temper 3-1mm, sparse sub-rounded quartz sand 0.5mm, rare sub-angular lime 0.5-0.2mm, grey black inclusions 0.1mm. Wheel-made Meroitic fabric from red-slipped jars.



FAB 101 Whitish marl amphora fabric. (AD5)28 Pale, yellow-white, poorly-mixed marl 7mm, bands of white marl. Common sub-rounded quartz sand 0.5-0.3mm, sparse rounded ironstone 1.5-0.5mm. Vesicles common. Black mineral inclusions, shiny and poorly sorted. 0.2mm sub-angular. Very rare, possibly resulting from an error in production, although found in more than one area. Wheel-made. No diagnostics, so date uncertain but most likely borderline between the late Napatan and early Meroitic.



FAB 102 Orange matrix with white flecks. Napatan amphora. Common sub-angular white lime or milky quartz, well sorted, 0.1-0.2mm. [In the past may have pushed some sherds into FAB 23 that should have been FAB 102, mainly due to change in FAB 23 sample sherd.] Orange red ribbed surface yellow-white (slip) 5mm light specks of lime 0.2-0.1mm common well sorted. Vesicles 1-0.3mm. Mica specks rare (AD5)49.



FAB 103 Amphora in (AC5)37 Fine clay matrix no or few visible inclusions, flaky flat break. Bright orange colour. Sparse longitudinal air holes. Rare sub-rounded lime. Red orange conchoidal break 7mm, paler outer surface? Sparse sub-rounded lime 1.5-0.3mm, sparse vesicles 1-0.2mm, sub-rounded ironstone, sparse 1.3-0.4mm, rare sub-rounded black inclusions (ironstone) 0.3mm, sparse mica specks, rare 1-0.2mm grog? Uncommon jar wheel-made (AC5)37.



FAB 104 Marl – Pale orange/pink matrix, wheel-made fine jug with 820er; not particularly granular look, jagged break. The fabric looks ready to flake, but perhaps due to being burnt? Small grog, long angular lime 1mm long, sub-rounded black inclusions c. 0.2mm Not very well-sorted, many different inclusions appear at different points. Related to fabrics 26, 40 and 88? Pale orange Nile silt (mix?) 3mm, hackly break sparse sub-angular lime 1-0.2mm, rare rounded grey inclusions 0.3mm, sparse fine vesicles (organics?) specks of sparse mica. Sparse red 0.1mm inclusions (grog?) closed globular form import? Red slip. (AD5)99.



FAB 105 Reduced core with white flecks. Red and black Nile silt, wall thickness up to 13.5mm. Organic inclusions, sparse sub-angular lime 1.8-0.5mm, common vesicles organic straw? 3-1mm, specks of mica sparse. Usually wheel-made. R18 (HA2).



FAB 106 Reduced core with white flecks. Similar to, but less coarse than, FAB 105. Red and black Nile silt with purple and brown bands, average wall thickness 9mm. Common prominent vesicles 0.3mm, rounded rare quartz sand 0.5mm, sparse mica specks, sparse sub angular lime 0.5-0.1mm, rare organic 2mm Meroitic red-slipped jar silt fabric. R18 (HA2)188.



FAB 107 Red brown with brown core, Nile silt, wall 4.5mm thick. Common organic inclusions 2.5mm, common mica specks, longitudinal vesicles (organics). Meroitic red-slipped bowl fabric (FT3)22.



FAB 108 Marl amphora with prominent red (grog?) inclusions. Pale yellow to beige marl with ironstone, 10mm thick. Common, poorly-sorted, angular ironstone, 4-0.2mm. Sparse quartz clear sand sub-angular 1mm, longitudinal vesicles, common sand sub-rounded 0.2mm red and black in colour. Napatan wheel-made jar fabric, 3402x similar to Western Oasis 25th-26th Dynasty? Q3 (AD5)168.



FAB 109 Marl – Grey matrix with numerous inclusions, sub-angular black particles 0.2-0.5mm, sub-angular dark brown grog (?) 0.5mm, rare lime with explosion chambers, 0.5mm, rounded sand (only impression of visible). Granular look to fabric, uneven break, average hardness. Probably used for amphora, but no diagnostic sherds.



FAB 110 Cooking pots, RBRIE and 910 ware. Red and black organic 10mm with rough surfaces that flake off, common organic temper 3-1mm, vesicles common, sparse sub-rounded quartz sand 0.6mm, rare lime rounded 0.2mm Handmade Napatan cooking pot fabric, common. (AC5)45.



FAB 111 Red Nile silt with wide range of inclusions granular appearance 8mm thick common sub-rounded quarts 2-0.5mm, some is milky coloured. Sparse vesicles, sparse organic temper 3mm long, common angular lime (reaction rims) 1.5-0.3mm, grog? Rare Napatan jar wheel-made fabric. (AC5)45.



FAB 112 Red, granular looking matrix. 11mm Sparse sub-angular lime 1.5-0.5mm, one with an explosion chamber; common mica specks, poorly mixed and sorted. Most likely of Meroitic date. Wheel-made jar fabric first found at R18 (JE3)13.



FAB 113 Nile silt – Amphora, wheel-made, ribbed, 825ew, (AC5)68. Dark brown to light brown and grey (banded firing). Noticeable white inclusions c. 0.5mm, some long and narrow air chambers. Less sandy and more granular than FAB 81. Micaceous surfaces, visible even through wash.



FAB 114 Marl – Formerly recorded as FAB 40. Friable fabric with salt. Friable, flaky fabric with pale cream slip that falls off (delaminates). Red fabric vesicles, sparse rounded dark sand 0.5mm, rare milky sub-angular quartz 1mm, rare specks of mica, tiny white lime rare reaction rims 0.2mm. Wheel-made jar fabric. (AD5)113.



FAB 115 Meroitic jar. Poorly mixed pale beige Nile silt-marl mix, organic 11mm strata of marl clay not mixed in, rare rounded clear quartz sand 0.5mm, sparse gold mica specks, sparse sub-rounded red inclusions (grog) 1-0.3mm, vesicles, common organic temper, rare sub-angular black inclusions 0.5mm, sparse white (lime?) sub-angular 0.3mm. Wheel-made slipped Meroitic fabric. Rare R18 (HA2)38.



FAB 116 Marl? – Grey core, pink surface, wall 8mm thick. Powdery, some rare vesicles, rare clear sub-rounded quartz, 0.5mm, rare orange sub-angular grog 0.5mm, sparse red ironstone? Sub-angular 0.5mm, sparse lime sub angular 2-0.2mm, rare black sub-angular inclusions 0.5mm. Wheel-made (AC5)49.



FAB 117 Micaceous, granular brown Meroitic jar fabric, wall 5mm thick. Common mica gold 1mm, rare lime and black inclusions, sub-rounded, reaction rim, grog? 1mm well-sorted, rare quartz, 3.5 x 2mm. Meroitic jar (FT3)3.



FAB 118 Organic Nile silt or mix beige to black, wall 8.5mm thick. Rare angular lime 0.5mm, common organic up to 4mm. Rare, poorly sorted rounded ironstone (?) 0.5-0.2mm, rare black inclusions sub-rounded 0.3mm, common to sparse mica specks. Wheel-made red-slipped Meroitic jar fabric similar to FAB 115. (FT3)3.



FAB 119 Fine orange brown fabric red band in middle. Sparse small vesicles, sparse sub-rounded red inclusions ironstone 0.3mm rare black blob Meroitic wheel-made fine ware? (FT3)10.



FAB 120 Red brown Nile silt – white slip surfaces. Organic straw inclusions and vesicles 6mm max, – clear quartz sparse 2-1mm, sub-rounded sparse lime 1-0.1mm, some with explosion chambers. Similar to FAB 94. (FT3)22.



FAB 121 Brown Nile silt – common, sub-angular white quartz, 0.5-0.2mm, sparse, sub-angular grog, 0.5mm, vesicles possibly from organics, but not clear. Rare and wheel-made (FT3)46.



FAB 122 Poorly-mixed silt marl fabric with white marl bands/strands, pale brown. Sparse sub-rounded clear quartz sand, 1mm, Sub-angular sparse lime 1-0.3mm, organic inclusions sparse 2mm, vesicles. Rare wheel-made early Meroitic fabric? Or error whilst mixing? (FT3)67.



FAB 123 Thin-walled wheel-made jar. Multiple inclusions, varying in size 1-0.2mm. Sub-rounded, black and white sand. Nile silt light brown with large inclusions. Common red and grey sub-rounded inclusions probably all ironstone 2-0.5mm, common rounded lime 2.5-0.5mm, rare quartz rounded 1mm, common rounded and sub-angular black inclusions. Napatan jar or beaker. No diagnostics. (AD5)168 jar.



FAB 124 Very micaceous Nile silt, apparently from thin-walled amphora. Fabric breaks in longitudinal layers, so very friable in present condition. (FS3)13 Egyptian in origin? Parallel at Quseir (R. Thomas, pers. comm.), biconical amphora.



FAB 125 Marl amphora fabric with large ironstone (?) inclusions very similar to 25th Dynasty Keg Ware and Fabric 31 and to a lesser degree 116, which however is more porous. Frequent sub-angular black sand and more finely pounded ironstone particles 0.2-8mm+ Wheel-made amphora, early (?) Napatan, (AD5)242, Building A4.



FAB 126 Wheel-made ribbed jar, Meroitic? Red to purple Nile silt, hard fabric bands of reds, purples and browns. sparse sub-rounded lime 0.5mm, sparse gold mica specks, organic inclusions 2mm long. Sub-rounded ironstone 1-2.5mm. R18 (JE3)2.



FAB 127 Imported amphora, slip smooth, not ribbed, surface grey-brown-pale dusty pink, core grey-orange/pink. Sub-rounded large lime inclusions most notable to naked eye, up to 2mm. Sparse sub-angular black inclusions 0.2-1mm, also sparse sub-rounded black inclusions. All fairly well sorted. Elongated air holes, 1mm each. Some of the lime has explosion chambers; hard fabric, well made and well fired. Wheel-made amphora fabric, provenance unknown. No diagnostics. (AC5)53 Building A2 rm II.



FAB 128 Marl – (AC5)77 Combination of marl fabrics 23 and 18 – pinkish green. Mottled appearance of matrix, well made but one large white quartz inclusion, c. 2mm. Other inclusions are difficult to see and or identify. Hard, well fired and well sorted. Colour possibly accident of firing, closer to 23 than 18. Wheel-made, ribbed Napatan amphora fabric. Egyptian import ?



FAB 129 Wheel-made jar/amphora, medium brown, common sub-angular clear quartz, sparse opaque grey quartz 0.2mm, well sorted. Rare air holes. (AD5)278, Building A3.



FAB 130 Orange colour matrix, with some straw and air holes. Inclusions include sparse lime (0.5-0.1mm), sparse black specks, sparse rounded grog. Inclusions are visible on the interior surface or where external slip is missing. Wheel-made. Meroitic.



FAB 131 Handmade, similar to FAB 59, Meroitic. Occurs at site 3-J-5 in the Fourth Cataract. Brown burnished, fine ware, bowls and globular jar, handmade, carinated bowls. (TG5)5.



FAB 132 Similar to FAB 80, with the same kind of dark inclusions, but with the addition of large lumps of poorly sorted lime (?). (TG5).



FAB 133 Fine matrix, pinkish colour. Occasional red inclusions (0.4mm) – possibly ironstone. Even, slightly conchoidal fracture. Very fine grained pink to buff matrix. Sparse air-holes. Wheel-made. (TG5)22.



FAB 134 Amphora (?) handle. Very sandy fabric, form reminiscent of 2917x (TG5)18. No diagnostics.

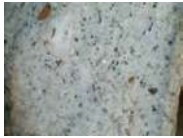

FAB 135 Amphora, grey, thick walled (18mm). Hard, hackly break. Common black sub-rounded inclusions, c. 0.4mm. Fairly common angular white quartz, 0.4mm. Rare sub-rounded red inclusions (grog?). Well-sorted. Surface pitted with quartz breaking through. No diagnostics. (FQ3)43.



FAB 136 Meroitic period amphora? Similar to FAB 103 and FAB 133. Wheel-made and rare at Kawa. Found in Areas C, T and J in the cemetery. Common sub-angular white and grey inclusions, 0.2-1mm; reasonably well-sorted. Diagnostic: 3684x (neck only).



FAB 137 Wheel-made jar, only four body sherds found, all in grid square (TG5), in levels that would support an early Meroitic date. Inclusions are common, including white lime and rounded ironstone. There were no diagnostic features on the sherds, but from the character of the fabric it is certainly an import, possibly from Aswan or further afield.



FAB 138 Wheel-made body sherds. The array of inclusions and the orange colour of the matrix are reminiscent of FAB 87, but this sherd did not have the same hardness; possibly a fault in the production process, but still the same geographic origin. Probably Napatan. No diagnostics.



FAB 139 A white kaolin fabric, coarser than FAB 26, used for similar wheel-made forms. Meroitic. Occurs in forms 3699x (3.6.2), 4332x (3.10.2), 4333x (3.2.10), 4334x (3.6.2).



FAB 140 Found in Area C and grid square (TG5), but extremely rare. Handle 4360x (3.2.1). Imported amphora, tentatively identified as Camulodunum 182 by R. Tomber from photo and drawing.

NO PHOTO

FAB 141 4321x is an import, found in topsoil at (TG5). Cream coloured, probably marl based, wheel-made. Most likely a storage jar, given handle fragment 4321x (3.12.4).



FAB 142 Imported Campanian wheel-made fabric. Sparse pinkish inclusions c. 0.4mm, sparse 0.1mm black inclusions, most likely volcanic augite, some vesicles, 1mm. Diagnostic: 4338x, table version of Dressel 2-4.



FAB 143 Wheel-made jar/amphora. Rich brown matrix, micaceous surface. Relatively frequent 0.2mm angular white and grey inclusions (quartz?), lime 0.1-0.5mm, some with explosion chambers. Medium to hard, hackly break. Because of the angular quartz sand, could be related to FAB 87? Otherwise colour and presence of mica rather different. No diagnostics.



FAB 144 Wheel-made Aegean fine-ware fabric, yellow to beige matrix with sparse inclusions. Belongs to a stirrup jar?

TABLE 2.1. THE FABRICS IN NUMERICAL ORDER.

0 refers to where no fabric was assigned. 'MULT' indicates that the fabric was present but recorded together with other fabrics.

FAB	TOTAL	(A)	(B)	(C)	(F) Kilns	Building F1	(FZ1)	(FZ2)	(TGS)	(Z)	Site R18
0	757/33,377	56/2,835	112/4,800	204/12,690	8/300	290/4,471	—	—	6/1,411	4/240	75/6,630
1	493/47,632	103/17,515	206/25,070	5/159	—	16/95	—	—	—	—	162/4,783
2	138/13,946	—	102/8,035	3/115	1/16	2/20	—	—	—	3/540	1/25
3	11/457	3/120	—	—	—	4/52	—	—	—	—	4/285
4	2/25	1/20	—	—	—	—	—	—	—	—	1/5
5	46/393	—	—	—	—	—	—	—	—	—	46/393
6	151/1,944	6/467	1/75	21/331	—	19/169	1/5	1/3	1/20	—	99/874
7	13/195	—	1/100	6/123	—	1/2	—	—	1/5	—	4/55
8	39/4,919	2/85	20/1,155	4/88	—	7/61	—	—	—	—	6/3,530
9	33/1,676	12/615	19/970	—	—	1/75	—	—	1/16	—	—
10	16/340	2/65	—	—	—	—	—	—	—	—	14/275
11	143/9,919	40/4,380	30/2,980	13/385	4/72	10/222	—	—	—	—	46/1880
12	98/4,625	14/1,898	10/725	5/530	3/30	1/40	—	7/25	—	—	58/1,377
13	54/1,610	7/184	22/802	3/107	1/10	3/29	—	—	1/8	3/14	7/312
14	30/468	2/35	5/95	1/35	—	2/70	—	—	3/38	—	17/200
15	45/4,603	—	—	2/18	—	2/150	—	—	—	—	41/4,435
16	31/4,303	1/5	4/160	2/37	—	5/38	—	—	1/15	—	18/4,048
17	20/1,548	40/2530	2/90	—	1/20	1/20	—	—	—	1/28	2/40
18	64/1,366	10/521	14/210	3/34	1/8	14/263	3/40	—	8/145	1/50	9/72
19	14/480	6/315	1/35	—	—	2/31	—	—	—	—	5/99
20	17/2,220	2/225	6/955	—	—	—	—	—	—	—	9/1,040
21	31/3,705	1/40	28/3,290	—	—	—	—	—	1/25	—	1/350
22	50/1,693	10/640	8/175	14/336	—	7/216	1/15	—	1/30	1/60	8/221
23	510/8,927	192/5,212	30/1,035	13/183	60/440	110/1,079	—	—	53/578	1/30	50/340
24	2/50	—	1/40	—	—	—	1/10	—	—	—	—
25	3,063/83,753	289/22,582	108/6,225	194/6,767	9/255	75/2,309	2/40	—	2,248/40,996	23/2458	115/2,081
26	42/665	1/5	10/85	5/110	—	—	—	—	4/12	—	22/453
27	36/820	12/383	1/15	3/40	2/72	16/300	—	—	—	—	2/10
28	1/60	—	—	—	—	—	—	—	—	—	1/60
29	21/1,561	3/106	2/55	1/50	—	—	—	—	1/20	—	14/1,330

FAB	TOTAL	(A)	(B)	(C)	(F) Kilns	Building F1	(FZ1)	(FZ2)	(TGS)	(Z)	Site R18
30	3/118	—	—	—	—	2/93	1/25	—	—	—	—
31	33/890	1/200	2/130	—	—	2/75	—	1/10	—	—	27/475
32	40/742	2/120	11/295	—	5/105	10/126	—	—	1/25	2/14	8/47
33	13/572	—	4/78	—	1/4	—	—	—	1/28	—	7/462
34	19/2,273	—	1/150	1/50	—	4/620	1/20	2/60	—	—	10/1,373
35	1/20	—	—	—	—	—	—	1/20	—	—	—
36	4/55	—	1/5	—	—	—	—	—	1/20	—	2/30
37	1/15	—	—	—	—	—	—	—	—	—	1/15
38	13/100	3/43	—	—	—	7/35	—	—	2/20	—	1/2
39	5/255	—	—	1/10	—	1/5	—	—	—	—	3/240
40	12/834	4/705	1/100	—	—	—	—	—	—	—	7/29
41	4/278	—	—	—	—	—	—	—	—	—	4/278
42	58/333	—	—	2/43	—	—	—	—	—	—	55/275
43	14/265	7/25	—	—	—	—	—	—	—	—	7/15
44	3/170	—	1/90	—	—	—	—	—	—	—	2/80
45	19/900	—	6/295	—	—	1/20	—	—	2/10	—	10/575
46	12/277	—	1/60	2/60	7/137	—	—	—	—	—	2/20
47	12/544	—	—	—	1/4	—	—	—	—	—	11/540
48	126/1,039	—	3/130	—	—	—	—	—	—	—	123/909
49	42/943	3/180	11/315	—	4/44	—	—	—	1/4	1/12	22/378
50	25/1,450	15/1,175	4/220	—	—	—	—	—	—	—	6/55
52	10/252	—	1/10	—	7/62	—	—	—	—	1/30	1/150
53	19/465	—	8/225	2/32	—	—	—	—	—	1/25	8/183
54	11/310	4/130	—	—	1/30	—	—	—	—	—	6/150
55	2/20	2/20	—	—	—	—	—	—	—	—	—
56	25/2,095	1/10	18/1,720	4/270	—	—	—	—	2/95	—	—
58	28/1,233	8/523	—	49/818	3/118	1/342	—	—	—	—	16/250
59	64/1,010	—	—	—	—	1/20	—	—	5/45	—	9/127
60	65/844	—	—	—	—	60/325	—	—	2/214	—	3/305
61	60/3,105	2/300	29/2,055	2/90	—	—	—	—	—	—	27/660
62	3/240	—	1/40	MULT	—	—	—	—	—	—	2/200
63	43/1,025	—	—	1/15	1/26	4/150	—	—	—	—	37/834

FAB	TOTAL	(A)	(B)	(C)	(F) Kilns	Building F1	(FZ1)	(FZ2)	(TG5)	(Z)	Site R18
65	996/56,060	621/41,978	124/5,070	44/1,850	—	54/1,859	—	—	73/3,562	3/205	47/1,497
66	49/3,196	17/1,297	26/1,595	1/100	1/18	3/36	—	—	—	—	1/150
67	9,697/322,242	1,110/98,001	857/77,085	606/32,798	2869/27,757	815/14,528	4/65	2/60	3,123/56,645	21/5,589	290/9,714
68	2/530	1/500	1/30	—	—	—	—	—	—	—	MULT
69	2,884/144,723	1,626/81,254	747/42,352	82/6,126	47/1,651	62/2,736	—	2/35	36/820	60/4,394	226/5,435
70	12/470	5/355	1/75	—	—	1/10	—	—	—	—	5/30
71	2,288/299,612	751/123,757	270/76,005	28/3,025	159/17,161	589/59,297	—	—	529/21,517	3/475	38/778
72	28/325	5/140	—	1/20	—	1/20	—	—	4/25	—	17/120
73	7/56	—	—	—	3/24	—	—	—	—	—	4/32
74	1/300	—	1/300	—	—	—	—	—	—	—	—
75	14/738	4/195	9/525	—	—	—	—	—	—	—	1/18
76	73/12,096	29/10,782	14/580	2/75	12/318	8/208	—	—	2/40	—	8/133
77	59/1,338	2/225	17/400	—	36/620	2/28	—	—	—	—	2/65
78	4/126	3/70	—	—	—	—	—	—	1/56	—	—
79	24/2,501	8/1,500	—	—	5/150	2/80	—	—	—	5/141	4/630
80	470/30,857	175/8,383	177/7,901	82/8,136	179/2,915	18/363	—	—	45/741	20/1,251	74/1,167
81	75/2,211	55/1,380	7/230	1/260	4/85	—	—	—	—	1/46	4/210
82	10/386	7/101	3/285	—	—	—	—	—	—	—	—
83	78/3,441	45/2,300	17/790	1/30	7/85	1/30	—	—	—	3/156	4/50
84	3/46	—	1/20	1/25	—	—	—	—	1/1	—	—
85	6/74	3/54	—	2/10	—	—	—	—	—	—	1/10
86	31/2,031	31/2031	—	—	—	—	—	—	—	—	—
87	138/6,011	86/3,798	8/450	4/105	2/50	6/377	—	—	29/1,171	—	3/60
88	47/1,286	10/464	7/280	1/50	3/28	1/20	—	—	2/5	—	23/439
89	1058/46,425	1013/43195	—	—	12/750	8/620	—	—	—	—	23/1,760
90	125/6,832	109/6584	—	—	7/80	3/118	—	—	2/50	—	—
91	25/1,720	11/775	10/850	1/15	—	1/10	—	—	1/35	—	1/35
92	54,902/1,251,601	16,236/634,514	871/61,908	929/51,886	2608/35,423	30,897/384,702	18/285	92/865	2019/47,417	—	1028/23,417
93	782/45,770	580/35677	30/3,200	13/570	4/78	23/772	1/10	—	59/2,334	58/2,905	17/374
94	6,545/357,347	2,366/125,776	498/51,554	1,129/90,554	39/1,381	450/20,638	71/730	29/355	1644/35,700	51/7,385	268/23,274
95	234/12,859	20/3,590	52/1,860	52/1,492	3/36	4/114	—	—	38/700	37/7,385	29/1,047
96	14/601	5/92	4/250	2/205	—	—	—	—	2/38	—	1/16

FAB	TOTAL	(A)	(B)	(C)	(F) Kilns	Building F1	(FZ1)	(FZ2)	(TGS)	(Z)	Site R18
97	64/5,633	36/3,847	15/1,255	3/157	3/90	3/80	—	—	1/14	1/125	2/65
98	280/17,265	143/10,852	—	7/158	23/438	55/4,443	—	—	43/1,171	3/110	7/118
99	9/95	—	—	7/60	1/10	1/25	—	—	—	—	—
100	176/19,324	21/1,142	—	—	22/1,320	17/459	—	—	9/240	1/10	106/16,153
101	11/305	3/170	—	3/65	—	—	—	—	2/40	—	3/30
102	2,051/51,662	310/5,391	—	15/255	7/268	1325/41,799	32/340	91/665	218/2,235	—	49/253
103	55/10,810	9/765	—	3/110	1/25	33/8,600	—	—	—	—	9/1,310
104	13/992	4/185	—	—	—	3/42	—	—	1/100	—	5/665
105	465/29,784	4/183	—	35/2,045	1/50	48/4,773	1/10	8/175	26/481	1/2120	352/22,357
106	611/37,549	—	—	98/6,575	16/880	8/186	2/30	8/180	25/518	—	463/29,693
107	46/272	—	—	—	5/30	—	—	—	2/8	—	39/234
108	48/1,119	12/365	—	23/294	—	1/25	—	—	—	—	12/435
109	7/116	2/23	—	1/18	—	2/50	—	—	1/5	—	1/20
110	76,123/1,042,007	17,546/262,431	5/145	1,815/10,4129	1,678/22,961	48,328/577,668	2,302/17,779	1,260/9,909	1,163/17,408	—	770/16,457
111	61/1,915	21/286	—	15/1,125	—	21/637	—	—	3/52	—	1/15
112	40/2,042	—	—	—	—	—	—	—	8/28	—	32/2,014
113	537/25,994	127/3,804	1/15	16/414	15/398	242/19,634	1/15	5/55	116/1,346	1/40	11/218
114	10/537	—	—	8/465	—	—	—	—	1/22	—	1/50
115	424/10,517	—	—	389/9,512	9/188	3/40	—	3/40	7/117	—	13/620
116	96/14,150	5/147	—	21/1,030	—	1/210	—	—	1/1	—	68/12,762
117	91/2,229	12/433	—	1/25	2/20	44/1,234	8/135	5/110	16/217	—	3/55
118	155/5,849	—	—	22/440	1/20	24/507	—	—	9/237	—	99/4,645
119	12/165	5/75	—	—	1/10	5/70	—	—	—	—	1/10
120	8/290	—	—	4/125	1/10	1/35	—	—	1/90	—	1/20
121	97/2,630	—	—	1/20	2/20	77/1,340	—	—	—	—	17/1,250
122	22/1,057	—	—	8/520	2/180	8/230	—	—	2/47	—	2/80
123	4/155	1/40	—	1/35	—	2/80	—	—	—	—	—
124	8/367	—	—	1/20	4/82	2/260	—	—	—	—	1/5
125	15/2,712	9/2,345	—	1/150	—	2/130	—	—	—	—	3/87
126	16/223	11/158	—	1/30	—	—	—	—	—	—	4/37
127	3/85	1/40	—	2/45	—	—	—	—	—	—	—
128	397/20,663	12/265	—	18/221	3/53	236/19,030	15/160	26/210	76/639	—	11/81

FAB	TOTAL	(A)	(B)	(C)	(F) Kilns	Building F1	(FZ1)	(FZ2)	(TG5)	(Z)	Site R18
129	40/810	19/405	—	12/185	—	4/70	—	—	—	—	5/145
130	418/25,492	—	—	330/9,294	22/452	3/80	—	—	14/322	—	48/15,319
131	31/488	—	—	23/253	—	—	—	—	1/10	3/30	4/195
132	272/21,234	—	—	167/4,198	17/219	1/20	—	—	10/215	—	77/16,582
133	13/140	—	—	12/130	—	—	—	—	—	—	1/10
134	2/50	—	—	2/50	—	—	—	—	—	—	—
135	3/215	—	—	—	—	2/180	—	—	1/35	—	—
136	13/475	—	—	3/125	—	—	—	—	6/175	—	4/175
137	4/200	—	—	—	—	—	—	—	4/200	—	—
138	2/40	—	—	—	—	1/20	—	—	1/20	—	—
139	6/872	—	—	—	—	—	—	—	1/3	—	5/849
140	3/427	—	—	1/75	—	—	—	—	2/352	—	—
141	2/234	—	—	—	—	—	—	—	2/234	—	—
142	1/1,373	—	—	—	—	—	—	—	—	—	1/1,373
143	8/120	—	—	—	—	8/120	—	—	—	—	—
144	1/5	—	—	1/5	—	—	—	—	—	—	—

3. The Forms

Categories of vessels

Within the sections below references are given and, if deemed necessary, a general description or discussion of a form or group of forms; in the relevant tables the data relating to each form is listed: the context(s) in which it occurs, the fabric(s), decoration, graffiti, surface treatment, diameter range and total rim percentage (RVE), as well as manufacturing method.

Transport and storage vessels, including imports, predominantly wheel-made:

3.1 Amphorae, Napatan in particular.

3.2 Various imported amphorae rims, Meroitic beer jars, flagons and small bottles.

Jars:

3.3 Wheel-made and handmade closed and open-mouthed jars.

3.4 Wheel-made jars, open storage jars.

3.5 Miscellaneous distinctive medium to large jar forms, mostly wheel-made (partly ribbed, flanged).

Bowls and basins:

3.6 Including decorated bowls and dishes.

The kitchen: drinking, cooking and storage vessels:

3.7.1-7.7 RBRIE.

3.7.8-7.25 Cooking pots, medium-sized storage jars. Mostly with inverted rims, but a few are straight sided.

3.8 Ware 910; coarse cooking and utility wares.

3.9 *Doka*, bread plates and basins, spouted basin; storage vessels, cylindrical bread ovens and coarse lids.

The ritual:

3.10 Beakers and offering dishes.

3.11.1-3.11.7 Braziers and incense burners; bread cones; pot stands.

The practical and the unknown:

3.11.8-3.11.11 Feeder cups; lids; crucibles; miscellaneous forms;

3.12 Bases (3.12.1-3.12.3) and handles (3.12.4-3.12.5) that are not specifically linked to a particular rim form.

Abbreviations

RCK = D. Dunham, *The Royal Cemeteries of Kush*. Vols I-V.

Ku. = Dunham 1950

Nu. = Dunham 1955

Bar. = Dunham 1957

Beg. N. = Dunham 1957

Beg. W., Beg. S. = Dunham 1963

MFA = Museum of Fine Arts, Boston, online collection.

Pot codes

700e band of grooves

702e finger marks by base (or rim)

800e/i red burnished exterior/interior

802 red burnished both interior and exterior

805e/i light brown burnish, vessel surface colour

R805e random brown burnish

810e/i black burnished exterior/interior

812 black burnished both interior and exterior

816 black top

820 slipped e/i, R = red, B = black, Gr = gray.

Next to slip code:

H e.g. H820, Horizontally applied slip/ burnish

OBL – Oblique burnish

RV – Random vertical burnish

V e.g. V820, Vertically-applied slip

822 slipped both exterior/interior. Note that when only one side is slipped (usually the exterior), the slip comes over the inside of the rim. The same is the case with a wash.

825e/i wash

830 painted

831e one painted band; 832e two painted bands, etc.

850 repair hole

851 suspension hole. Note that while a whole class of vessels (3.4.6) are often made with at least one pair of suspension holes, sometimes similar holes (e.g. 871 below) on closed vessels are unlikely to have been used for suspending the vessel and may have been used to allow air to circulate into them.

855e string impressions on the exterior of the body.

871 air hole, often made pre-firing, average diameter 15mm. Note that in some instances it is not recorded if the hole was made pre-firing! Some of the holes made post-firing may have been made to allow a fire to draw, when the pot was reused as an 'oven'.

898 sherds from the same pot, but no physical join.

910 smoothed surface by rim exterior and interior, rest of surfaces rough.

931e one incised groove under rim; 932e two grooves, etc.

999 conjoining sherds (used to indicate joints recovered from different contexts).

CRR: crackled rim, where the rim of the vessel has been allowed to dry out before firing without being smoothed. See for example 3832x, section 3.8.3.

Diameter (Dia): When a number or sequence of numbers is given in parentheses it is because the diameter varies significantly from the norm.

+ Signifies that the form is also illustrated by a photo. Unless specifically stated, all forms, decoration types and graffiti are illustrated by a drawing.

Form abbreviations

BC bread cone

BKR beaker

BJ beer jar

BO bread oven

CP cooking pot

IB incense burner

B	base
BS	body sherd
H	handle
HS	handle scar
R	rim
SH	shoulder

Manufacture

HM	handmade
WM	wheel-made
SW	slow wheel
CB	coil built
B hole	base hole
R notches	rim notches
H	horizontal
TR	traces of
V	vertical
VAR	minor variant of the type specimen
OX	oxidised
OF	over-fired
UF	under-fired or unfired.

Colours

R	red
BL	black
BG	beige
BR	brown
CR	cream
GR	grey
O	orange
P	pink
PLE	purple
Y	yellow
RBRIE	red band on rim, interior and exterior, c. 20mm wide.
NRBRIE	narrow RBRIE, c. 10mm or less;
RBRI	red band by rim interior only;
RBRE	exterior only;
RBR	red band on very top of rim only.

For further discussion of some of the features listed above, such as slip, RBRIE, ware 910, CRR, firing mishaps and various types of perforations, see Chapter 8.

A note on the arrangement of the pottery

In the course of recording the pottery in the field, each new form was given a number starting from 2000, followed by an 'x', to indicate that the number relates to a form; decoration types are suffixed with a 'y' and graffiti with a 'g'. Each newly recognised type was drawn, and when another example of the same shape or decoration was found, it was given the same type number. For convenience the form type series is divided into 12 sections. Within each section and page, variations on a particular form are, where relevant, presented from inverted to everted. The aim has been to favour ease of finding a form, rather than a chronological arrangement, for the purposes of looking up parallels. For example, in Figure 3.3.8 form 3040x is most likely early Meroitic, while form 3539x is probably Post-Medieval,

but the similarity in form (and the relative rarity of each) has resulted in them being placed together. The type series has undergone innumerable rearrangements to make it as logical as possible for ease of locating a form, and while it could doubtless still be improved upon, a line has been drawn at this point. The numbering of the figures (3.1.1, 3.3.4, etc.) is listed in the tables, discussion and plates, so that it is easy to find the relevant information whether one starts from image or text. Consequently in the context of the forms in Chapter 3, figure and section references are the same. The same system is also used in the chapters on the Decoration and Graffiti, 4 and 5 respectively. As not all forms are illustrated by a photograph (+), the numbering of the plates does not follow the same pattern, but the figure/section is referenced next to the individual photographs.

When listed in a column dedicated to form (x), decoration (y) and graffiti (g) the type numbers are not followed by their suffixes. However, except in Chapter 5, graffiti are always given the 'g' suffix to avoid confusion with decoration type numbers.

When a cemetery context number is followed by a hyphen or simply no grave number, the context could not be ascribed to a particular grave.

In the case of grid square (TG5), in the course of excavating the baulk that had been left by the stone gate this was excavated in spits, hence the occasional context ranges listed: 86-99, etc.

In a number of instances in the tables it is indicated that a particular specimen is 'from brick'. This refers to sherds that originally had been mixed into the clay of mud bricks used within the kilns. This fact is relevant as such sherds are contemporary with or pre-date the kiln in question, rather than being contemporary with the actual context they were found in.

3.1. Amphorae, Napatan

Presumably all (?) of the marl variants are imported from the Theban region in Egypt (Vincentelli 2018b, 181), the fabrics ranging from pure marls to a possible mixture of marl and Nile silt (clay). The general shape of the vessel may have undergone some changes over time (or were made in different workshops?) but the same general characteristics (rilled rim, a pair of small handles below the shoulder, frequently ribbed) remained the same, making them easily identifiable. The many *almost* identical amphorae of this type found in Building F1, are dealt with in more detail below in Chapter 6; here only the different rim forms and the main body types are discussed. In order to save space and because the lower body and base are very similar, in most instances only the upper body is shown in the figures, but this is the case only of amphorae from Building F1. In all other cases the types are represented as complete as possible (and this is of course the case elsewhere in the type series). For occurrences of these amphorae in the course of Griffith's excavations, see Laming Macadam 1955, II, pl. XXXII.1a-d,f ([2082], [2026], [2060] [2064] and [2027]) and in other parts of Kush, see Budka 2007, 81, fig. 8.4 (Fourth Cataract); Lohwasser 2010, 40, fig. 19: Shaft-tomb 0497, Napatan amphora set in a basin (?) at Sanam Abu Dom; Reisner 2018, figs 33-39

and 46-49, reproduced in *RCK* and Wolf 2015, 115-131, fig. 6, amphora from cemetery 3-J-1280/3-O-428 (Meroe region). Note that many have the intriguing base hole, discussed below (Chapter 6, pp 351-3). Miniature faience copies of both a typical Napatan (e.g. 4626x) and Levantine amphora were found at Sanam (Griffith 1923, 104, 124, pl. XXXII 1 and 2, from grave 949) and perhaps also of form 4016x (3.1.10) (*ibid.*, pl. XXXI 2). For more recent work and more Levantine amphorae at Sanam and also at the nearby cemetery of Hillat el-Arab, see Vincentelli 2018b and 2006 respectively.

Following the chronology proposed by Aston (2007, 426-7, fig. 5), the jars (in the parlance of this volume, the amphorae) with the rim standing up at right angles to the shoulder (Aston's Group II), such as 4755x (3.1.6) are earlier (700-600 BC) than the 'classic' pear-shaped Napatan amphorae, which run from 550-400 BC (Group V in Aston). Variants of this latter group, such as 3221x, 4799x and 4800x (all three made of Nile silt fabrics, 3.1.4) belong in Group V. However, at Kawa both variants are found together in Building F1, for example the rim of 4664x (3.1.6 & Figure 6.3, no. 18) is angled to make one continuous line with the curve of the body. The two types may have coexisted for some time, as it seems unlikely that in Building F1 we are looking at a very long occupation span.

The current theory regarding the Napatan amphorae is that they were used to transport grain rather than liquids (such as oil or wine) (Vincentelli 2018, 132). Thin walled as they are, and without any resin coating on the interior, they would indeed not have been suitable for storing, let alone transporting liquids over any length of time.

3.1.1 Miscellaneous beaded rims

Some resemble New Kingdom 'meat pots'.

2538x: Vila 1980, fig. 24.2 (approximate comparison), note this vessel has a base hole and a graffito (fig. 188.2, but not a parallel to any of the Kawa graffiti, although the mark on the left is similar to the letter 37, [Masson 1978, fig. 1.]).

3363x: Aston 1999, pl. 2. 30, 19th Dynasty.

3421x: Heidorn 2018, 325-6, fig. 4c (Ku.3 [5, 690-664 BC] 19-3-587)? Note that the diameter at Kawa is smaller, and there is no evidence of handles.

3933x: Aston 1999, pl. 8.176 19th Dynasty. Or 20th-21st Dynasty? cf. Aston 1999, pl. 11.283.

3947x: Ku.18 (4, 701-690 BC) fig. 23b, 19-2-358; cf. also photograph of the same vessel, MFA acc. no. 20.2728 (there dated to 712-698 BC), with four handles; Boulet 2017, fig. 2.c; 2018 fig. 1j (25th Dynasty).

4005x: Late Napatan.

4042x: Compare with Aston 1999, pl. 90.2395 (4th century BC).

4077x and similar forms: At Sanam, 25th-26th Dynasties (Vincentelli 2018b, 179, fig. 1.1).

4174x: Ku.55 (2, 751-716 BC) 94, fig. 31b, 19-3-1469; Heidorn 2018, 320 fig. 2a, giving a revised date of the 7th century BC.

4290x: see Aston 1999, pl. 72.2041, 5th-4th century BC, late Saite/Persian period. Also Jacquet-Gordon no date, fig 17.2.

3.1.2 Miscellaneous Napatan amphora with rilled rims

These types of vessels, occur throughout Egypt at Gurna, Karnak, Elephantine and Ashmunein, (cf. Heidorn 1994, footnote no. 18 for a bibliography of this form in Egypt). To date I have not located any examples outside Egypt apart from in Nubia.

+2113x: Nu.18 (13, 538-533 BC) fig. 115, 17-4-942, red ware. 2113x, 2493x (1.3), 2980x, 3318x and 4431x, cf. Nu.20 (7, 653-643 BC) fig. 20, 17-2-139, red ware, with handles further down body than present specimens.

2818x: Napatan

2996x: Boulet 2017, fig. 2.a; rim is similar to Vincentelli 2006, fig. 2.97 608 and pl. 2.2.1, Hillat el-Arab tomb ARA 19 (19th to 25th Dynasty). The vessel has a hole pierced near the base.

3318x: Nu.9 (11, 568-553 BC) fig. 93, two red ware vessels, no number.

3925x: Ku.16 (6, 664-653 BC) fig. 21b, 19-2-392.

4163x: Boulet 2017, fig. 2.g, but a little thinner wall; 2018 fig. 1d (25th Dynasty).

4242x: Rilly *et al.* 2020, 87-88 fig. 30 II T 301 Cd 06. Early Napatan.

4600x: Unusually made of Fabric 69, but pale brown and with very sparse lime.

4838x: Aston 1999, pl. 64.1870, late 8th or 7th century BC.

3.1.3 Variants of Napatan amphora with rilled rims

See Nowotnick 2018, fig. 4, amphorae of marl, and fig. 8, of Nile clay.

2415x: Ruffieux 2007, pl. 2.11 [17-21], marl clay; Vila 1980, fig. 29.2, Missiminia, Grave 2-V-6/46, hard and grey fabric and with two sets of double handles. Base hole purposely made, and two incised marks near the handles, neither resembling the marks at Kawa; Vincentelli 2001, fig. 5.b.

2608x: approximately Vila 1980, fig. 130.1 type III-5.

2709x: Williams 1990, fig. 30e and pl. 9b, cemetery VH near Qustul, grave VH111. This example has a base hole and rim ticks.

2816x: Boulet 2017, fig. 2.f, 25th Dynasty; Rilly *et al.* 2020, 87-88, fig. 30. II 240/150 Cs 04. Early Napatan.

3992x: Budka 2007, 81 fig. 8.4, with a base hole (located quite high, c. 5cm above centre of base), made of a hard and dense Nile silt fabric, with a red wash; Napatan.

3996x: Nu.36 (5, 690-664 BC) fig. 10, 17-3-1861.

4229x: similar to Orzechowska 2003, pl. 1d, Napatan; Zurawski 2005, 209 fig. 16d, Napatan, at Soniyat Temple.

4234x: Rilly *et al.* 2020, 87-88 fig. 30.II 200/110 Cs 15. Early Napatan.

4297x: Heidorn 2018, 318, fig 1d, 25th Dynasty.

4837x: Three similar examples were found in the course of the NDR Survey (Welsby Sjöström 2001, J44.11), but the fabric was different; in the course of the survey two marl examples were found, while this one is of Nile clay, but different to the NDR silt example. There is a similar rim in Aston 1999, pl. 64. 1869, late 8th or 7th century BC.

3.1.4 Plain, nearly unrilled rims and examples of locally made Nile clay rims and profiles

2690x: Mohamed Ahmed 1992, fig. 24 II A12 (6th to mid 5th centuries BC).

+**3221x:** Height 48cm, width 24.6cm. Nu.2 (16, 553-538 BC) fig. 128, 18-3-504, from foundation deposit, red ware and hole in base. Also Nu.7 (15, 513-503 BC) fig. 123, 17-4-451.

3994x: Nu.7 (15, 513-503 BC) fig. 123, 17-4-451, with mud bung still in place.

4221x: Boulet 2017, fig. 2.a; 2018, fig. 1f (25th Dynasty).

+**4800x:** Nu.5 (12, 553-538 BC) fig. 108, 18-4-8, red ware; Nu.7 (15, 513-503 BC) fig. 123, 17-4-451; Nu.26 (12, 553-538 BC) fig. 111, 17-4-1142 slimmer form; Nu.29 (17, 478-458 BC) fig. 136, 18-3-880, from foundation deposit, with hole in base; Nu.30 (15, 513-503 BC) fig. 125, 17-4-1316, with hole in base; Nu.55 (11, 568-553 BC) fig. 102, 18-1-439; rim and wall vertical. Vincentelli 2006, pl. 2.2.1, although the rim lacks any rilling/grooves, similar to +4799x (height 37.3cm, width 20.7cm), but the body is more like 4800x; and like both parallels at Kawa, it also has a base hole. Also similar to 3221x (3.1.4).

3.1.5 More delicate rilled rims and profiles

2490x: Boulet 2017, fig. 2.e; 2018 fig. 1a (25th Dynasty); Rilly *et al.* 2020, 87-88, fig. 30 II T 356 Cc 04. Early Napatan.

4115x: Aston 1999, pl. 56.1871, 1885; Aston 2007, fig. 5, group 1 [1697], 700-600 BC. Cf. also Heidorn 2018, 324-5, fig. 5b, albeit thicker wall and top of rim slightly different – from Ku.72 (4, 701-690 BC) fig. 35b, 19-3-1554; Vincentelli 2006, ARA 18, vessel 534, fig. 2.82.

4626x: Aston 1999, pl. 71.2037; Aston 2007, fig. 5 group 5 [2037], 550-400 BC; Ku.55 (2, 751-716 BC), pl. 43Ac, 19-3-1459; Wolf 2015, fig. 6, greenish marl clay, most likely equivalent to Fabric 18 (*infra*); Vincentelli 2001, fig. 5.a.

4663x: For the graffito (189g) rather than the form, cf. Nu.23 (9, 623-593 BC) fig. 48, 17-3-492.

4679x: Graffito 211g only; Nu.23 (9, 623-593 BC) fig. 48, 17-3-492.

3.1.6 Progression of rilled rims

From inward sloping to vertical, forming a short neck.

4755x: Aston 2007 fig. 5 group 3 [1698], 700-600 BC.

3.1.7 Larger diameter rilled rims

With larger volume capacity.

+**4678x:** Height 44.2cm, width 27cm. Ku.52 (3, 716-701 BC) fig. 28c, 19-3-1160, also pl. 43A.1, red ware, rim a little thicker; Boulet 2017, fig. 2.d (25th Dynasty). See also Vincentelli 2018b, pl. 1.1, Egyptian marl import at Sanam Abu Dom.

3.1.8 Miscellaneous rims of large diameter and variants thereof

3609x: Boulet 2017, fig. 2.b (25th Dynasty).

3898x: Vincentelli 2018b, 179, fig. 2.1, with unusual paired

handles, no evidence for this recovered at Kawa, but only a few rim fragments were recovered. 25th-26th Dynasties.

4226x: Aston 1999, pl. 63 [1867], mid 8th and 7th century BC; also found at Amara West, but in an insecure context (Binder *et al.* 2011, 60); Boulet 2018, fig. 1h (25th Dynasty).

4739x: Ruffieux 2007, pl. 2.12 [17-22], marl clay; Napatan.

4740x: Boulet 2018, fig. 1k (25th Dynasty).

4756x: Aston 2007, fig. 5 [1785] group 3, 650 BC; Boulet 2018, fig. 1h; Orzechowska 2003, pl. 1f, 2nd half of 7th century BC? Also bears a resemblance to the rim of an amphora from Sarafand, see Lehmann 1998, fig. 3 n. 25 (after Anderson 1988, pl. 37:12, 750-700 BC). Żurawski 2005, 299, fig. 16f (Napatan, Egyptian import).

3.1.9 Miscellaneous Napatan amphora bases

3284x: Bottom half with pronounced ribbing (and 820er), Orzechowska 2003, pl. 23m, Napatan. Note that 3284x is red-slipped on the exterior.

3.1.10 Jars with beaded rims

A short vertical neck, apparently without handles. Note similarities between some of these forms and those in 3.3.1 that are more inward sloping. For a generic example of this type, see Dunham 1950, Ku.72 (701-690 BC), fig. 35b. Occurs together with a cup with a variant of decoration 1204y (see below).

2112x: Mohamed Ahmed 1992, fig. 15 I A4e (early 8th to early 5th century BC, more common later in the period).

2505x: Mohamed Ahmed 1992, fig. 24 II A6a (early 7th-mid 5th centuries BC).

2691x: Boulet 2017, fig. 3.a, 25th Dynasty; Phillips 2003, pl. 14a, Napatan. Vincentelli 2006, fig. 2.74 472, Hillat el-Arab tomb ARA 16, Napatan.

2851x: Ku.19 (B, 840-820 BC), fig. 24c, 19-3-864 HR-WYSL.

3306x: Nu.31 (19, 453-423 BC) fig. 154, 17-4-1346, but with handles; without handles; Vila 1980, fig. 24.3, grave 2-V-6/36; fig. 29.4, type II-4A. Williams 1990, fig. 21.c, cemetery W2 near Qustul, grave W85. The rim is slightly different, but the form and the general type are almost identical.

3312x: Ruffieux 2007, pl. 1.1 [17-20], Nile clay. Note also similarity of full profile to 3306x (rim slightly different, though); Żurawski 2005, 299, fig. 16e, Napatan.

4011x: Nu.36 (5, 690-664 BC) fig. 10, 17-2-1856 red ware; Heidorn 2018, 326, fig. 6a, 25th Dynasty, with further bibliography; Vincentelli 2018b, 180, fig. 2.2, in Nile silt fabrics, 25th-26th Dynasty.

4013x: Mohamed Ahmed 1992, fig. 15 I A4e (early 8th to early 5th century BC, most common early 6th century).

4016x: Ruffieux 2007, pl. 1.1 [17-20]. Napatan.

4018x: With a sharper shoulder break, Nu.11 (19, 453-423 BC) fig. 151, 17-4-750, from foundation deposit.

4019x: Orzechowska 2003, pl. 1e, Napatan?

4026x: Ku.T4 (A, 860-840 BC) fig. 3a, 19-3-411 PRW.

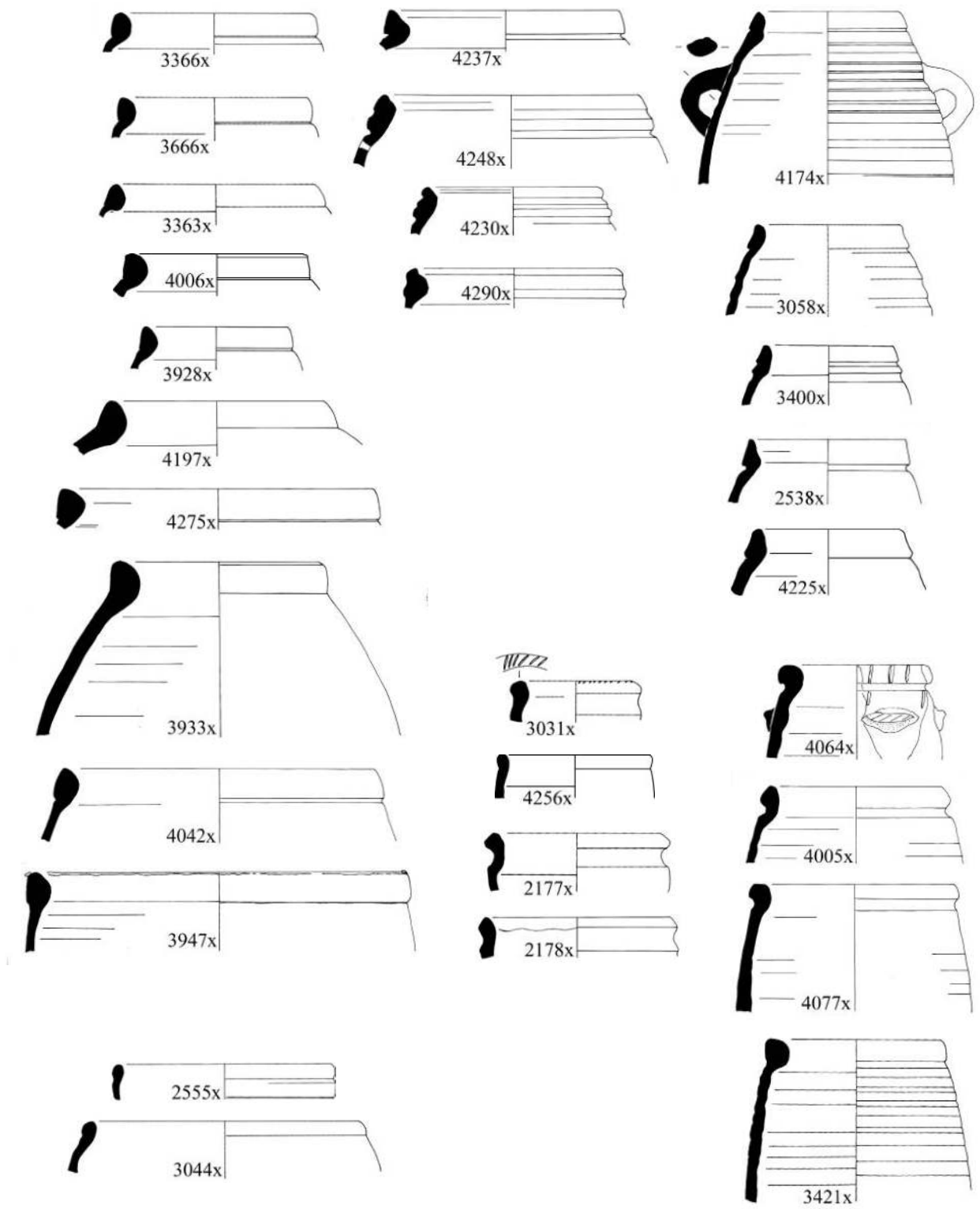

Figure 3.1.1. Miscellaneous amphora (?) rims (scale 1:4).

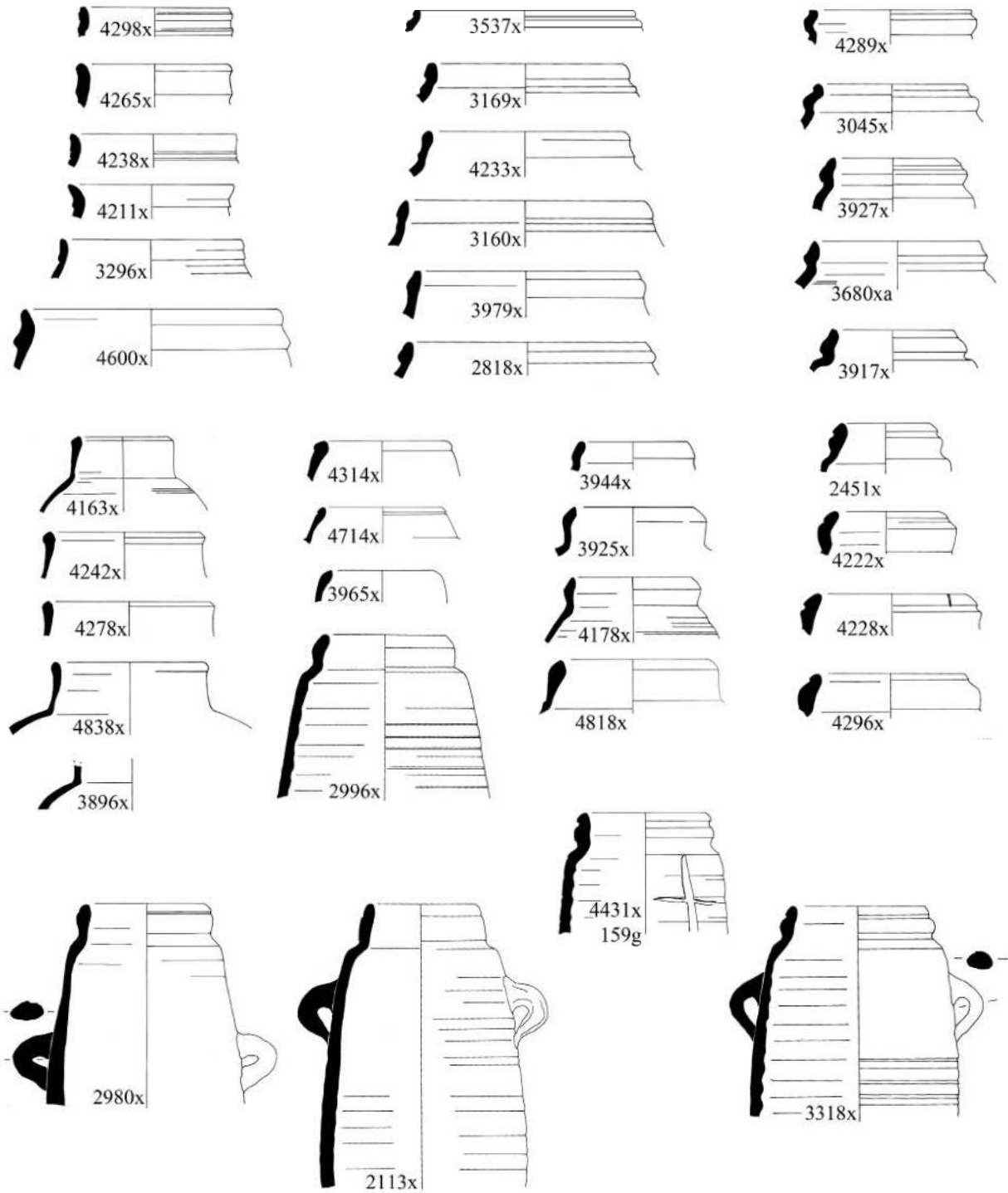

Figure 3.1.2. Typical Napatan amphora rims and variants thereof (scale 1:4).

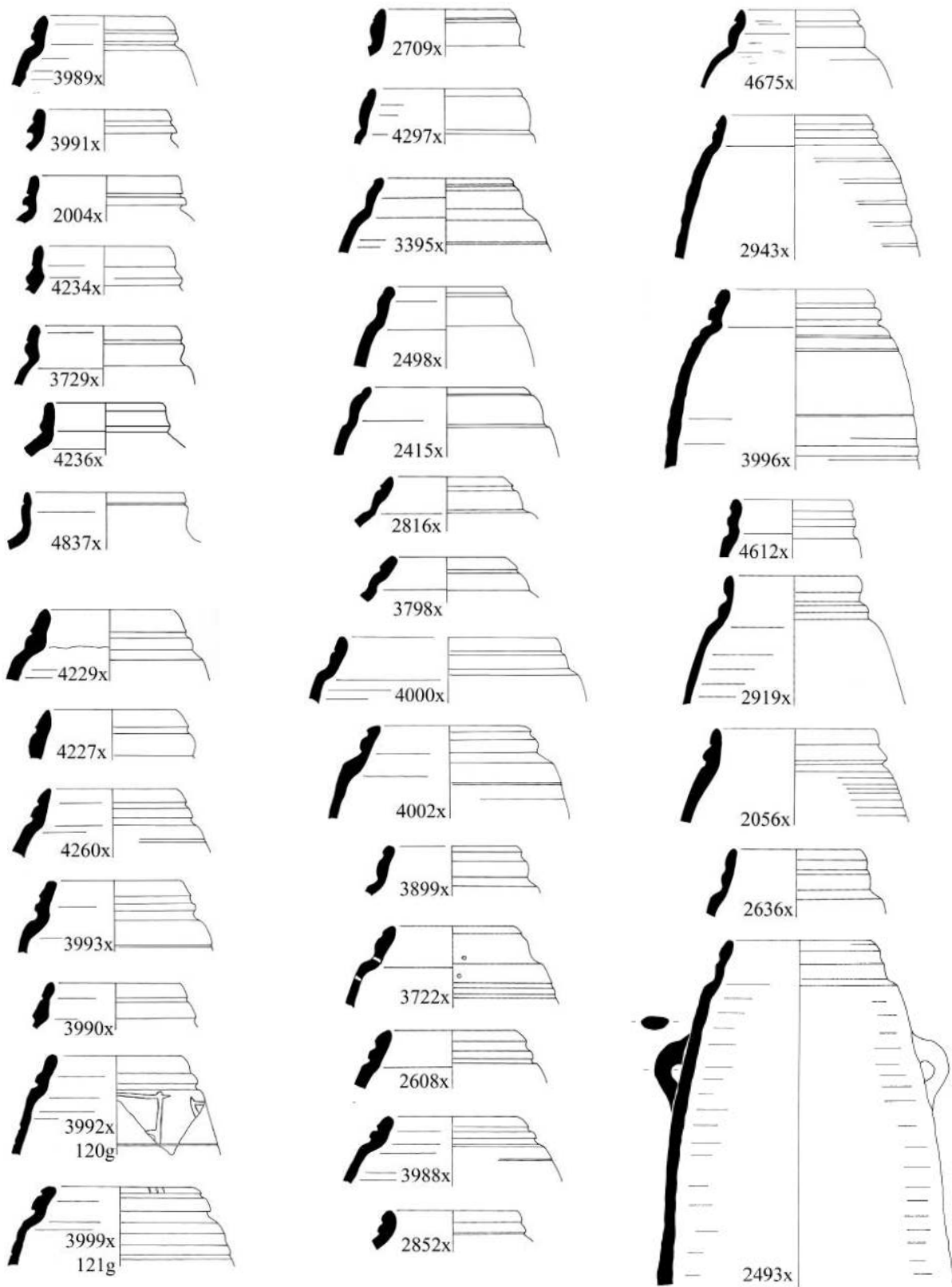

Figure 3.1.3. Variants of Napatan amphora rims (scale 1:4).

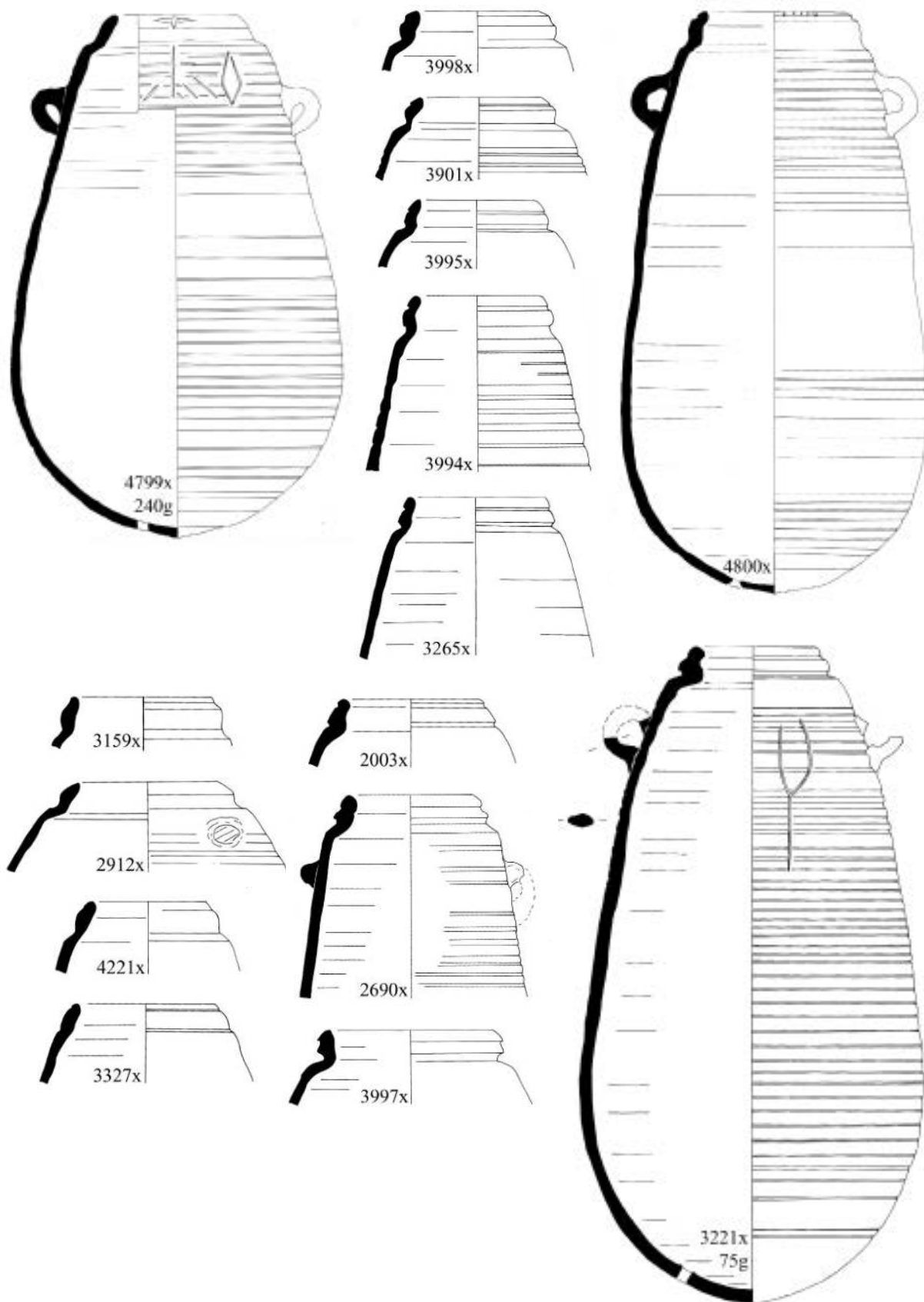

Figure 3.1.4. Napatan amphorae with squat rims (scale 1:4).

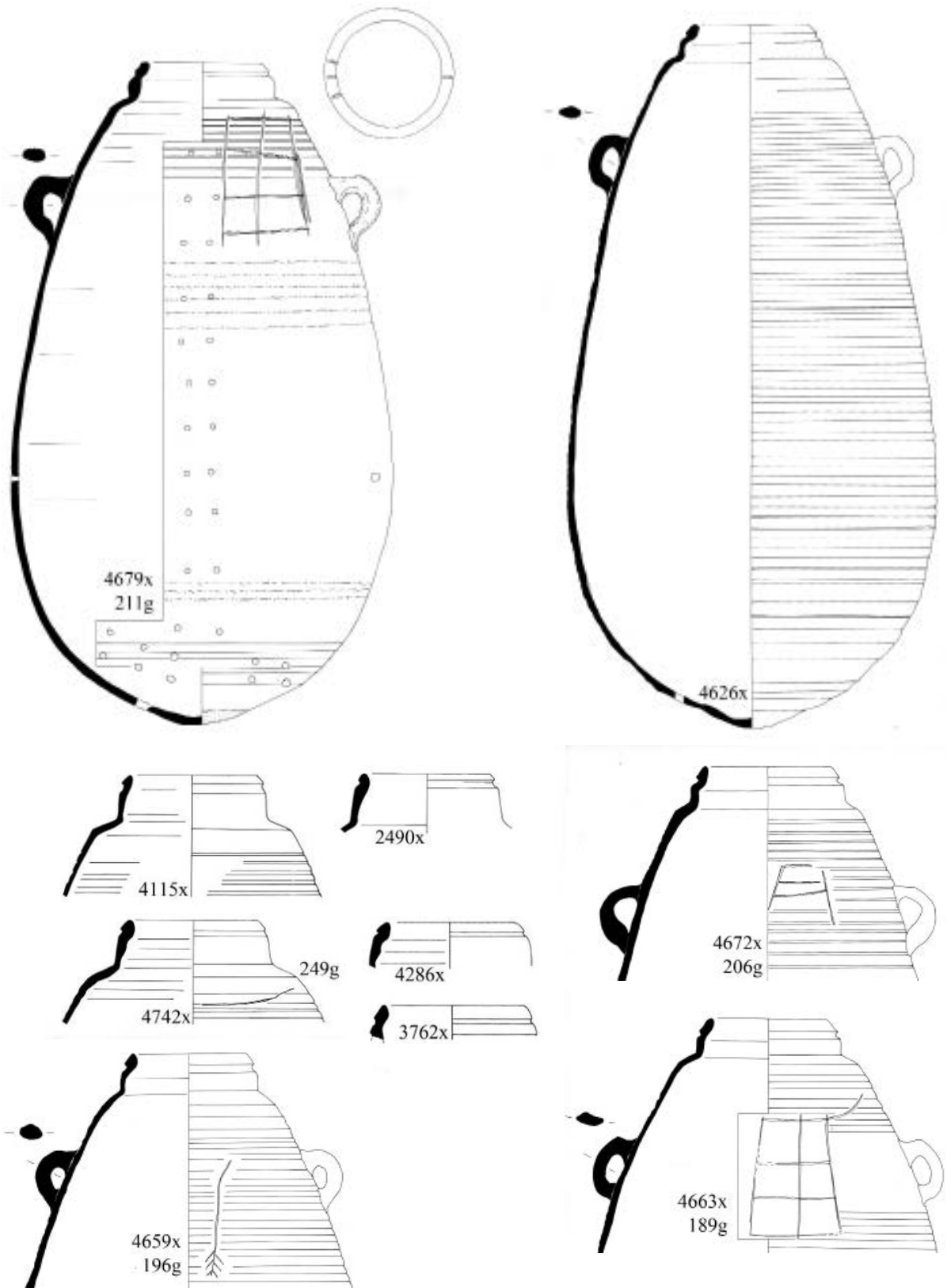

Figure 3.1.5. Napatan amphorae with thin and delicate rilling (scale 1:4).

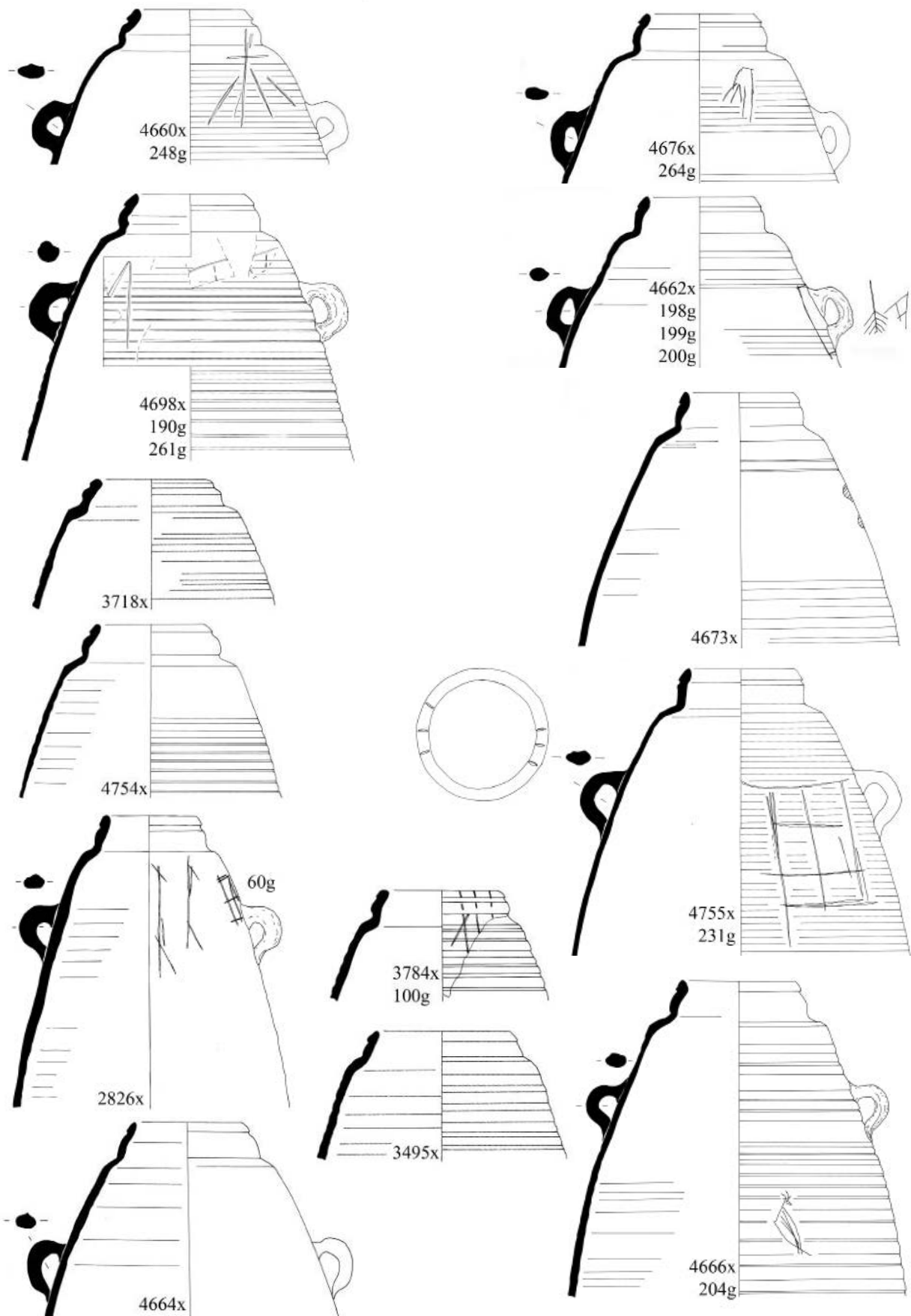

Figure 3.1.6. Napatan amphorae, with varying inclination of the rim, forming a short neck (scale 1:4).

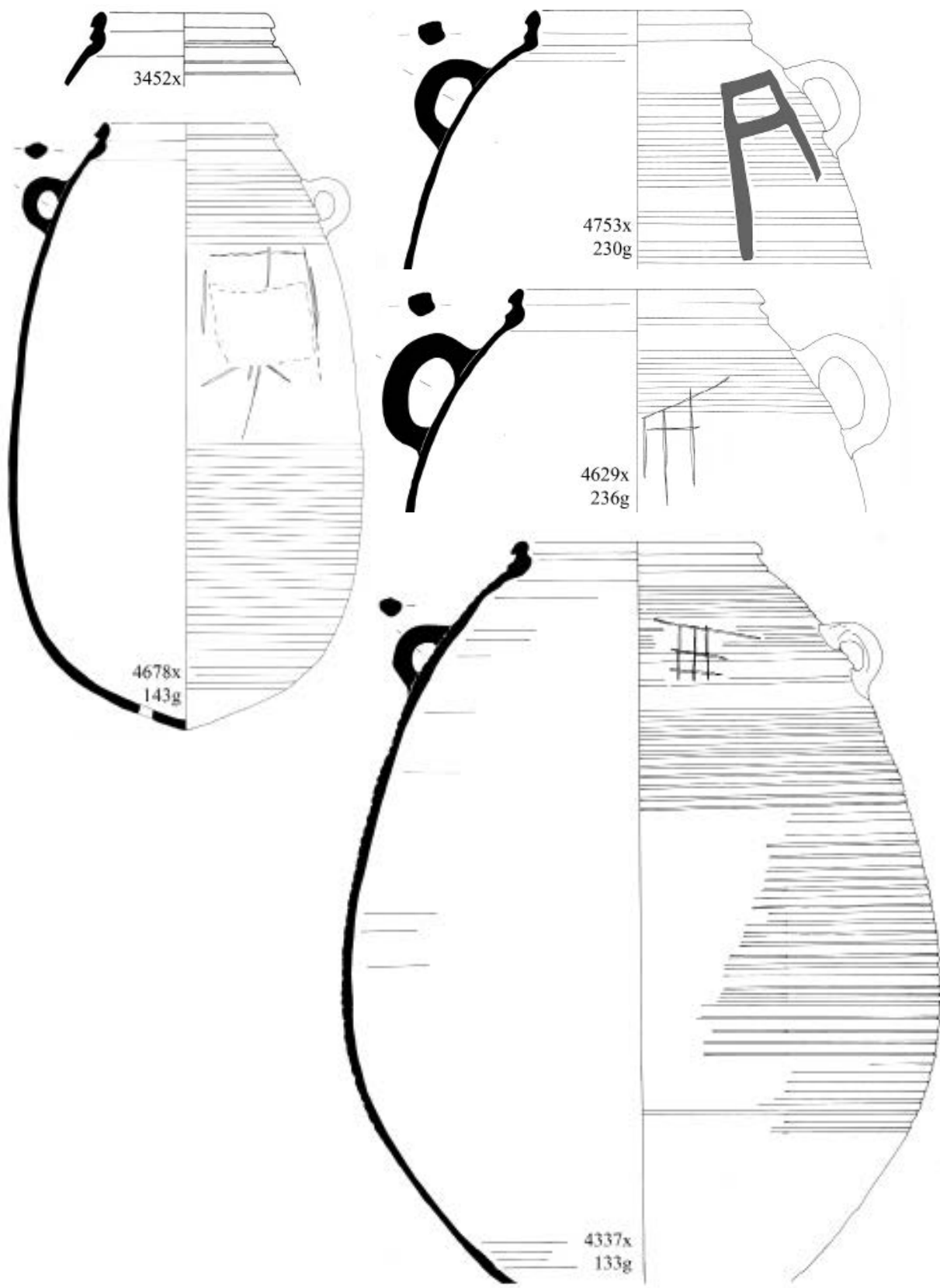

Figure 3.1.7. Examples of the larger sized Napatan amphorae (scale 1:4).

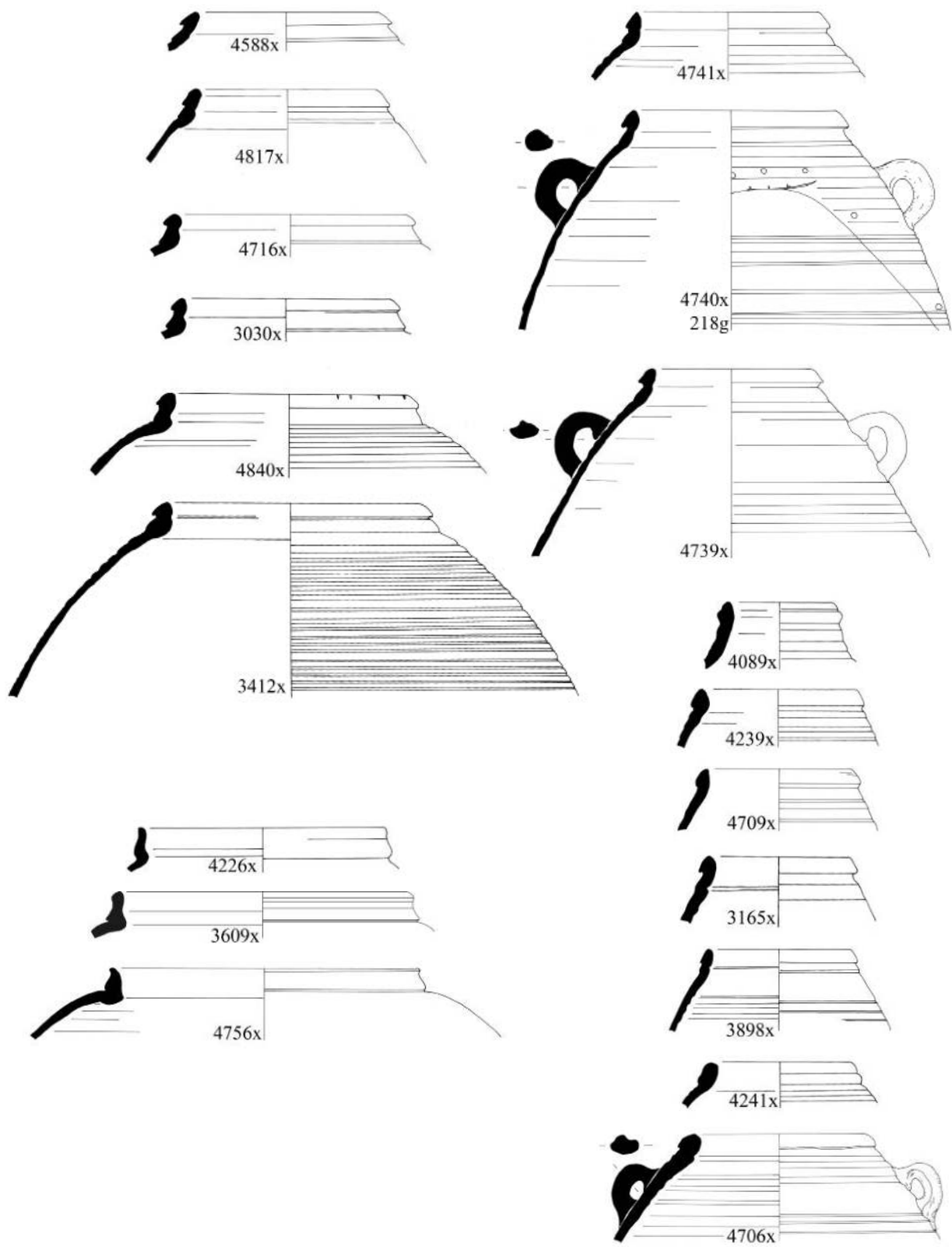

Figure 3.1.8. Variations on the squat rim of the larger sized Napatan amphorae and variants thereof (scale 1:4).

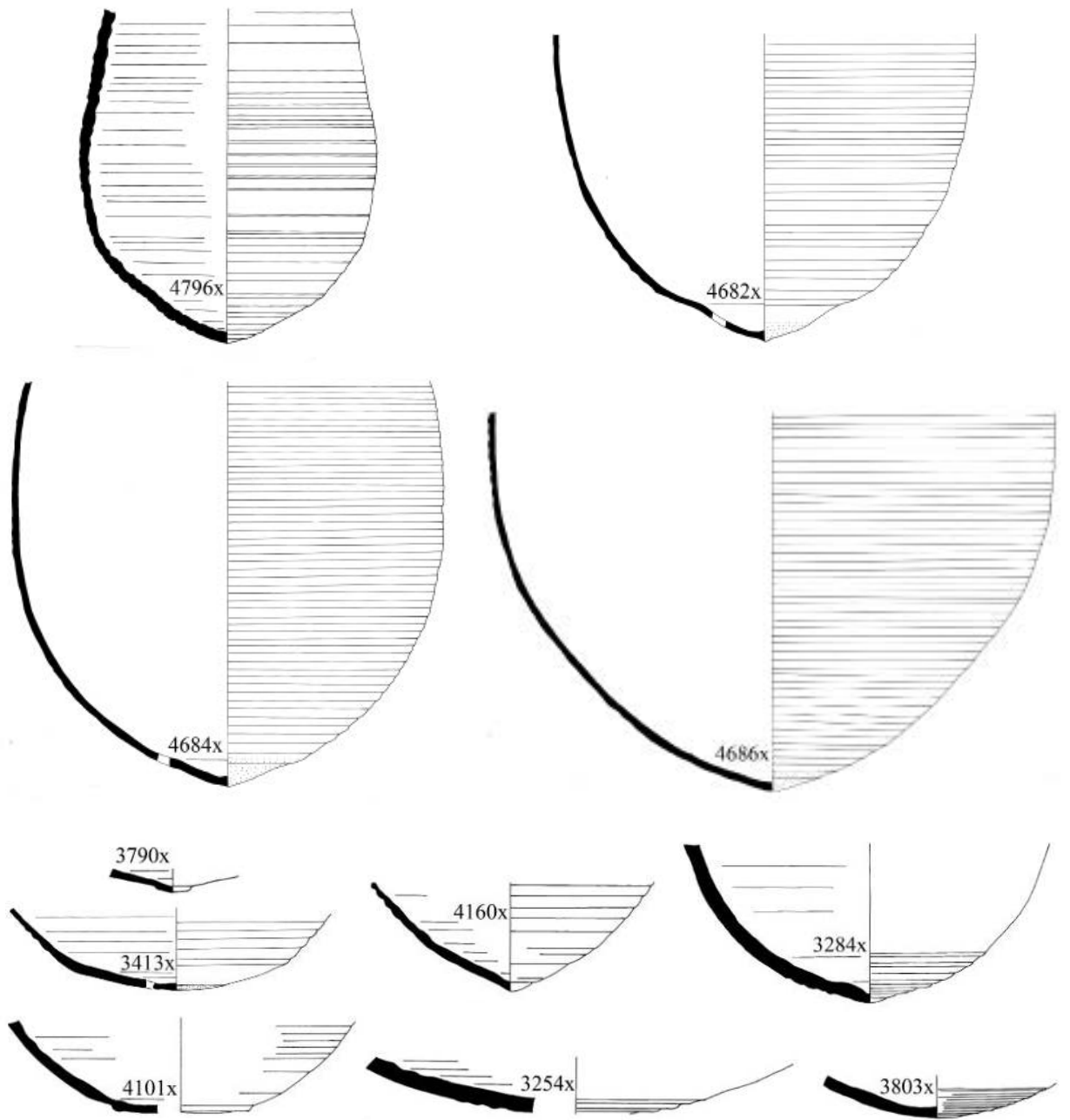

Figure 3.1.9. Bases of Napatan amphorae (scale 1:4).

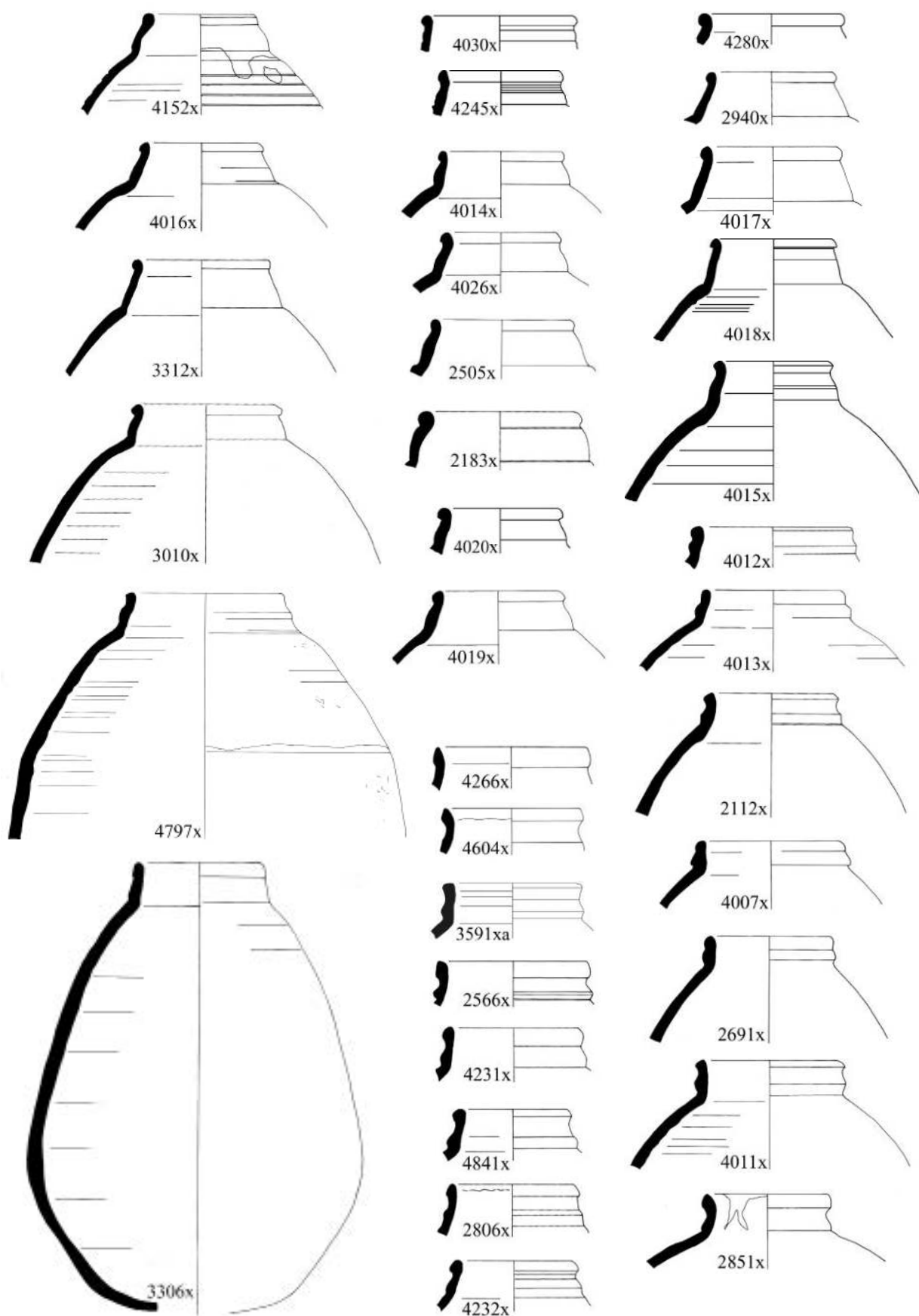

Figure 3.1.10. Jars, apparently without handles, with beaded rims and short necks (scale 1:4).



Plate 3.1.
Napatan amphorae.

TABLE 3.1. NAPATAN AMPHORAE AND OTHER NARROW-NECKED JARS.

Fig. no.	Type	Provenance	Fabric	Dec.	Surface treatment	Dia.	%	Man.	Comments
3.1.1	2177	(BE3)57	9		820ER (800E)	12	12	WM	
3.1.1	2178	(BE2)43,78,109 (BE3)8,57 (BE4)13 (BF3)8,50 (TG5)4	25 69 80 92 94		822W 825ECR 825EW 830EW	7-23	54	WM	
3.1.1	2538	(AB4)23 (BD3)12 (BE2)68 (FR3)1 (TG5)94	65 67 69 77 92		820EW 825EBR	11-24	76	HM WM	
3.1.1	2555	(AB4)1	92		825ER	15	10	WM	
3.1.1	3031	(ZH5)19	-	1112		8	-	WM	
3.1.1	3044	(AB5)273	25F		825EW	19	4	WM	
3.1.1	3058	(AC5)23,46	67 102		825EW ribbed	10-15	16	WM	
3.1.1	3363	(AD5)192	80/98			14	11	WM	
3.1.1	3366	(AD5)161	17			13	19	WM	
3.1.1	3400	(AC5)65,72,76	93 94 94F		825EIW 825EW 820EP/ CR	9	29	WM	
3.1.1	3421	(AC5)67	93		825EIW ribbed	12	47	WM	
3.1.1	3666	(TG5)18	93			12	1	HM	
3.1.1	3928	(FQ4)2 (TG5)86-99	92 122F			10-11	30	WM	
3.1.1	3933	(FO6)15	94			14	7	WM	
3.1.1	3947	(TG5)44	-			26	-	WM	
3.1.1	4005	(TG5)87	69			12	25	WM	
3.1.1	4006	(TG5)87	94			13	13	WM	
3.1.1	4042	(TG5)1,91	23 94F		825EY ABR	14-22	21	WM	
3.1.1	4064	(TG5)91	94			10	14	WM	rim notches
3.1.1	4077	(TG5)73	67			14	13	WM	
3.1.1	4174	(FP6)20	113		825ECR ribbed	10	21	WM	
3.1.1	4197	(FP6)36	-			15	11	WM	
3.1.1	4225	(TG5)95	-			10	-	WM	
3.1.1	4230	(TG5)96/102	-			12	-	WM	
3.1.1	4237	(TG5)102	-			16	-	WM	
3.1.1	4248	(TG5)84	-			18	-	WM	
3.1.1	4256	(TG5)87	94L		820ER	10	14	WM	
3.1.1	4275	(TG5)77	102			22	15	WM	
3.1.1	4290	(TG5)74	102			14	6	WM	
3.1.2	+2113	(AB6)1 (AC6)1 (BD2)27 (TG5)29,73	69 93 94 113	831EBL	825EW	8-10	65	WM	
3.1.2	2451	(AB5)277 (AC6)18 (AD5)25,161A (BE3)18	18 23 98 102		825EW	6-10	72	WM	
3.1.2	2818	(AB5)59 (FR3)22 (TG5)18	14 67 80			9-20	28	WM	
3.1.2	2980	(AB4)23 (AC5)99 (TG5)12,117	92F 93 94 98			8-15	130	WM	
3.1.2	2996	(AB5)347 (AC5)13 (AD5)161	65 93			8-9	49	WM	
3.1.2	3045	(AB5)273 (FO7)85 (FT3)1	14 93 103		825EW	8-10	40	WM	
3.1.2	3160	(FS3)1	69			16	9	WM	
3.1.2	3169	(FS3)1	98			13	11	WM	
3.1.2	3296	(AC5) 57	102			12	6	WM	
3.1.2	3318	(AD5)87 (FQ4)7,37	67 80 113		ribbed	18	46	WM	
3.1.2	3537	(HA2)187 -	92		ribbed	18	3	WM	
3.1.2	3680a	(TG5)29	113			11		WM	
3.1.2	3896	(FR4)9 (TG5)12,116	49 102 128		820EY	3-7	12	WM	
3.1.2	3917	(FQ4)21	80			8	32	WM	
3.1.2	3925	(FQ3)40	102		825EW	8	15	WM	from brick?
3.1.2	3927	(FQ3)40	80			8	10	WM	
3.1.2	3944	(FR4)7	106			7	8	WM	
3.1.2	3965	(FQ4)23 (TG5)112	102		825EW	7-8	17	WM	

Fig. no.	Type	Provenance	Fabric	Dec.	Surface treatment	Dia.	%	Man.	Comments
3.1.2	3979	(CE4)1 (FQ3)42	67 69			8-15	32	WM	
3.1.2	4163	(FO6)118,148	23			6	16	WM	898
3.1.2	4178	(FP6)21	98		ribbed	8	10	WM	
3.1.2	4211	(TG5)103	-			11	-	WM	
3.1.2	4222	(TG5)95	-			7	-	WM	
3.1.2	4228	(TG5)99	-			10	-	WM	1 rim notch
3.1.2	4233	(TG5)102	-			13	-	WM	
3.1.2	4238	(TG5)105	-			11	-	WM	
3.1.2	4242	(TG5)86	102			10	5	WM	
3.1.2	4265	(TG5)4,85	80 94		825EW	10	26	WM	
3.1.2	4278	(TG5)77	128			11	8	WM	
3.1.2	4289	(TG5)114	80			10	12	WM	
3.1.2	4296	(TG5)65	94			10	16	WM	
3.1.2	4297	(TG5)65	94		825ER	10	9	WM	
3.1.2	4298	(TG5)65	23		825EW	10	11	WM	
3.1.2	4314	(TG5)74	94F			8	10	WM	
3.1.2	4431	(TG5)1	93	159g		8	19	WM	
3.1.2	4600	(TG5)1	69			17	11	WM	
3.1.2	4714	(FP6)154	128			8	2	WM	
3.1.2	4818	(FZ2)31	102		825EW	10	18	WM	
3.1.2	4838	(TG5)29-105	23			10	9	WM	
3.1.3	2004	(AB5)67,86 (AC6)22 (BD2)50 (BE1)1 (BE2)48 (BF2)1 (TG5)1	65 67 88 93	850 x 1	825EW/R	9-11	154	WM	
3.1.3	2056	(AB4)11 (AB5)64,86 (AC5)34 (AD5)1,87 (BD2)34,63 (BE3)57 (BF1)4	25 65 67 69 92 100		820EW 825EIW	8-11	183	WM	
3.1.3	2415	(AB5)27 (AC5)13 (AC6)12,20,22,23 (AD5)249,255,272 (AD6)13,19 (BE3)70 (CE4)42,48 (FO6)71, 93,129,155,172 (FO7)85 (FP6)34 (FQ3)59 (FQ4)7,37 (FR3)00 (JE2)1 (TG5)1,29-105,74,105	23 65 69 80 82 93 94 94C 98 102 111 113		820ER 825EW 825IW(P) ribbed	7-12	392	WM	(FO6) 71, 93 oil-stained
3.1.3	2493	(AB5)1 (AC6)23,30 (BF1)56 (FP6)151	23 65 93 98		825EW ribbed	9-10	76	WM	
3.1.3	2498	(AB4)7 (AB5)1,52 (AC6)12 (FP6)109 (TG5) 1	65 80 92 93 113		825ER ribbed	7-12	62	WM	
3.1.3	2608	(AB4)11 (AB5)80,220 (AC5)49	65 89 92		820EW	9-10	109	WM	
3.1.3	2636	(AB4)1,14 (AB5)63 (AC5)17,127 (BD2)81	67 69 93		825EW	9-11	70	WM	
3.1.3	2709	(AC6)12	97			9	32	WM	
3.1.3	2816	(AB4)31 (AB6)24 (AC5)53,67,107 (AC6)54,58 (AD5)168, 186,214,236,278 (AD6)11,16 (CE5)1 (CF4)1 (FO7)73 (FQ4)33,37 (FR3)13 (TG5)105	18 23 76 92F 94 98 102 111 113 128	850	825ER 825EW ribbed	7-11	1377	WM	
3.1.3	2852	(BD2)1,71	13 67			9-11	27	WM	
3.1.3	2919	(AB4)20	65			9	72	WM	
3.1.3	2943	(AB4)33 (AD5)87 (FQ4)2 (FT3)9	65 69 76 92		825EW	9-10	59	WM	

Fig. no.	Type	Provenance	Fabric	Dec.	Surface treatment	Dia.	%	Man.	Comments
3.1.3	3395	(AD5)168 (FO7)2,86 (FP7)117 (FQ3)43 (FQ4)23 (TG5)89,116	65 94 98 102 113		825EW ribbed	8-9	185	WM	
3.1.3	3722	(AD5)242 (TG5)1,86	93 94 113	850 x 2	ribbed	8-9	92	WM	
3.1.3	3729	(AC6)19	98		825EW	10	58	WM	
3.1.3	3798	(AD5)260	128			8	13	WM	
3.1.3	3899	(FQ3)58 (TG5)29-105,113	94 98 113		820EW RBRI	8-11	22	WM	
3.1.3	3988	(TG5)91	98		820EW ribbed	9	27	WM	
3.1.3	3989	(CF4)1 (TG5)73,87	93 98		825EB ribbed	8-9	50	WM	
3.1.3	3990	(TG5)73,87	93		820EW ribbed	9-10	25	WM	999
3.1.3	3991	(CE4)1 (TG5)87	65 128		ribbed	9-10	23	WM	
3.1.3	3992	(TG5)73,87	92 93	120g	ribbed	9	44	WM	
3.1.3	3993	(TG5)73	94		ribbed	9	49	WM	
3.1.3	3996	(TG5)73	94 98		820EW ribbed	9-10	36	WM	
3.1.3	3999	(TG5)73	93		ribbed	10	79	WM	14 rim notches
3.1.3	4000	(TG5)73	98		ribbed	15	7	WM	
3.1.3	4002	(TG5)73	93		825EW ribbed	10	13	WM	
3.1.3	4227	(TG5)96	-			9	-	WM	
3.1.3	4229	(TG5)99	-			9	-	WM	
3.1.3	4234	(TG5)102	-			9	-	WM	
3.1.3	4236	(TG5)102	-			8	-	WM	
3.1.3	4260	(TG5)89	94			9	15	WM	
3.1.3	4612	(TG5)4/5	93			10	11	WM	
3.1.3	4675	(FO7)90	103		825EW ribbed	8	39	WM	
3.1.3	4837	(AB6)8	92			10	7	WM	
3.1.4	2003	(AC5)8,59 (BD2)28 (BE1)63 (BE3)50,69,78 (BF2)1,40 (FS3)2	23 67 69 80 92 93 94			9-15	128	WM	(BE3)69 & 78 999 waster
3.1.4	2690	(AB4)11,23 (AC5)17,38,68 (AD5)87,112,118,167 (BD2)96 (FQ3)8 (TG5)29	65 69 92 93 94 102		825ECR 825EW 825EIW ribbed	9-18	214	WM	(FQ3) from brick
3.1.4	2912	(AC6) 59 (CF4) 84 (JG1) -	69 80 92			9-11	32	WM	
3.1.4	3159	(CF4)113 (FS3)1	67 93			9-10	39	WM	
3.1.4	+3221	(AD5)20,41,61,69,154	98	75g		8.8	50	WM	999 base hole
3.1.4	3265	(AD5)126,127 (FQ3)0 (FQ4)62	92 93 102			8-12	77	WM	
3.1.4	3327	(AD5)102 (TG5)29	69 98			10	50	WM	
3.1.4	3901	(CF4)1 (FQ3)58 (FQ4)35 (TG5)65	23 98			8-9	42	WM	
3.1.4	3994	(TG5)73-91	98		ribbed	8.5-9	76	WM	
3.1.4	3995	(TG5)73	98			8.5	53	WM	
3.1.4	3997	(TG5)73	98		ribbed	12	31	WM	
3.1.4	3998	(JG2)1 (TG5)17,73,74	94 98 106 113		ribbed	8-9	61	WM	1 rim notch
3.1.4	4221	(TG5)95,117	65			10	11	WM	
3.1.4	+4799	(GD3)83A gr. 38	130	240g 241g	ribbed	7.5	100	WM	
3.1.4	+4800	(GD3)107D gr. 98	130		ribbed	9	100	WM	base hole 7 x 9mm, rim notches
3.1.5	2490	(AB5)1 (AC5)67 (AC6)8 (FT3)2 (FZ1)8 (HA2)12 -	23 69 83 102		825EW 825EIO	7-18	75	WM	
3.1.5	3762	(AC5)77	93			10	16	WM	
3.1.5	4115	(FP6)5,37,61 (FP7)34 (FZ2)1	23 102 113		825EW ribbed	8-9	89	WM	(FP6) 37 reused
3.1.5	4286	(TG5)120	128			9	10	WM	
3.1.5	4626	(FO7)2	102		825EGR ribbed	8	22	WM	

Fig. no.	Type	Provenance	Fabric	Dec.	Surface treatment	Dia.	%	Man.	Comments
3.1.5	4659	(FO7)20,65,90	102	196g	825EGR ribbed	8	100	WM	pre-firing base hole
3.1.5	4663	(FO7)3,39	113	189g	825EGR ribbed	8	100	WM	
3.1.5	4672	(FO7)17	113	206g	825EW ribbed	8	100	WM	oil-stained
3.1.5	4679	(FO7)1,16,20,30,52,90,94,98 (FP6)97 (FP7)95	-	211g MULT 850	ribbed	8	100	WM	rim notches
3.1.5	4742	(FO7)2	128	249g	825EW ribbed	9	38	WM	
3.1.5	4191 =4626	(FP6)37 (FP7)5,17,103,105,106,122	113	234g	825EW ribbed	8	5	WM	6.2 oil-stained
3.1.5	4685 =4626	(FO7)52,53,69,78,79,85,86,90,94 (FP7)10,39,117	102	217g 219g 265g	ribbed	7.5	100	WM	photo only
3.1.5	4657 =4672	(FP7)21	113		825EW ribbed	8	8	WM	photo only
3.1.5	4665 =4672	(FO7)20	113	183g 185g 186g		8	100	WM	6.2 oil-stained
3.1.5	4667 =4672	(FO7)76	102	225g	825EW ribbed	8	31	WM	6.2 photo only
3.1.5	4669 =4672	(FO7)22a	102	260g	825EW ribbed	8	100	WM	6.2
3.1.5	4670 =4672	(FO7)78	103	205g	825EW ribbed	7	55	WM	6.2
3.1.5	4671 =4672	(FO7)65,86	102	197g	825EW ribbed	8	100	WM	6.2 rim notches
3.1.5	4674 =4672	(FO7)90	103	226g	825EW ribbed			WM	6.2
3.1.5	4680 =4672	(FO7)85	128	207g 208g	825EW ribbed	8	42	WM	6.2
3.1.5	4816 =4672	(FO6)62 (FO7)2 (FP6)105 (FP7)2,19,70,92,102,124,128	103	250g	825EW ribbed	8	19	WM	6.2
3.1.6	+2826	(AB4)23 (AC5)128 (AC6)22,27 (AD6)13 (CF4)1 (FO6)90,91,92,100,116 (FR3)2,4 (FZ2)22 (JG1)-(TG5)29,74,117	23 65 76 82 92F 98 102 113 128	59g 60g 213g	825EW 825IP ribbed	7-10	169	WM	(AC6) 898 rim notches
3.1.6	3495	(AD5)230,239 (FQ4)2	94 102		ribbed	9-13	17	WM	
3.1.6	3718	(AD5)241,242 (FQ3)8 (FQ4)21	98 113		825EW ribbed	8010	76	WM	rim notch
3.1.6	3784	(AC5)77 (CF4)108 (FO7)2,52,31 (TG5)105	92S 94 113 128	100g	825EW ribbed	8-9	104	WM	rim notches
3.1.6	4660	(FO7)20	102	201g	825EW ribbed	8	30	WM	
3.1.6	+4662	(FO7)20a	103	198g 199g 200g	825EW ribbed	8	85	WM	oil-stained
3.1.6	4664	(FO7)23,79,85,90 (FP7)95	102 113		825EW ribbed RED B	8	44+	WM	min. 2 vessels??
3.1.6	4666	(FO7)69	103	204g	825EW ribbed	8	100	WM	
3.1.6	4668 =4755	(FO7)20	103		825EGR ribbed	8	100	WM	6.2 rim notches base hole
3.1.6	4673	(FO7)65	103		825EW ribbed	8	40	WM	
3.1.6	4676	(FO7)2,20,65	113	264g	825EW ribbed	8	100	WM	
3.1.6	4698	(FP7)17	113	190g 261g	825EGR	8	25	WM	
3.1.6	4754	(FO7)2,31,52	-		ribbed	8	50	WM	
3.1.6	4755	(FO6)131 (FO7)65,78,90	18	231g 850	- ribbed	8	100	WM	base hole rim notches
3.1.6	4681 =4662	(FO7)20,65,77,88	102 113	210g 850	825EW ribbed	9	85	WM	6.2
3.1.6	4658 =4755	(FO7)85	128	202g 203g	ribbed	8	100	WM	6.2

Fig. no.	Type	Provenance	Fabric	Dec.	Surface treatment	Dia.	%	Man.	Comments
3.1.7	3452	(CE5)1 (FR3)12 (TG5)117	23 69 94		825EW	11-22	29	WM	
3.1.7	+4337	(FO6)145	128	133g		17	100	WM	133g & b
3.1.7	4629	(FO7)20b (FZ1)24 (FZ2)1	102 103 113 128	236g	825EW ribbed	16-19	200	WM	
3.1.7	+4678	(FP6)9 (FP7)2,3,5,17	98	143g 144g	ribbed	11.5	77	WM	
3.1.7	4753	(FO7)65,67,69,76,78, 85,89,90 (FP7)19,39, 65,69,89,95,102	128	230g	ribbed	15	52	WM	
3.1.8	3030	(FR3)2 (FT3)44 (FZ2)1 (TG5)74 (ZH5)14	32 76 102		825EW	10-16	40	WM	
3.1.8	3165	(FS3)2,3	32			10	41	WM	
3.1.8	3412	(AC6)71 (FP6)1 (FQ3)43 (FZ1)9	23 102 113		825EW ribbed	15-19	71	WM	
3.1.8	3609	(TG5)13	-			20.5	-	WM	
3.1.8	3898	(FQ3)58 (TG5)1,12	65 113			10	37	WM	
3.1.8	4089	(TG5)94	-			7.5	-	WM	
3.1.8	4226	(TG5)96	-			17.5	-	WM	
3.1.8	4239	(TG5)103,113	98			11-15	12	WM	
3.1.8	4241	(TG5)86	113			10	10	WM	
3.1.8	4588	(CF4)74,75	23		825EW	15	14	WM	
3.1.8	+4706	(FP6)151	98			12	23	WM	
3.1.8	4709	(FO7)123	98F			10	12	WM	
3.1.8	4716	(FP7)72	102		825EW	16	9	WM	
3.1.8	4739	(FO7)42D,65	102		ribbed	15	81	WM	
3.1.8	4740	(FO7) -	102	218g	825EW ribbed	15	35	WM	
3.1.8	4741	(FO7)65	128		825EW ribbed	14	28	WM	
3.1.8	4756	F1	18			22	27	WM	
3.1.8	4817	(FO7)2	103		825EW ribbed	14	31	WM	
3.1.8	4840	(TG5)74	113			15	10	WM	
3.1.9	3254	(AD5)154 (AC5)34	31 92			-	40	WM	
3.1.9	3284	(AC5)46 (AD5)60,157, 242 (FO7)1	86 92 94 102 103		820ER 825ER 825EGR 825IBR ribbed	(16)	280	WM	2 base holes 10-11mm
3.1.9	3413	(AC5)76 (AD6)13 (FO6)129 (TG5)76	23 102	85g	825EW ribbed		65	WM	
3.1.9	3790	(AC5)73 (FO6)62,129 (TG5)130	23 98 102		825EW ribbed	-	65	WM	hole in base
3.1.9	3803	(AC5)129 (AD5)268, 272 (CE4)14 (TG5)1,16	92 92F 94 102 115		825IBL	-	915	WM	
3.1.9	4101	(FO6)34	113			-	-	WM	
3.1.9	4160	(FO6)107 (FP6)20,34, 57	102 113		825EW ribbed	-	205	WM	post-firing hole
3.1.9	4682	(FO7)65	103		825EW ribbed	-	100	WM	base hole 13mm
3.1.9	4684	(FO7)85	102	850	825EW ribbed	-	95	WM	
3.1.9	4686	(FO7)86	103		825EW ribbed	-	60	WM	
3.1.9	4796	(GD3)21 gr. 20 92,150 gr. 95	130		ribbed	-	70	WM	no wear
3.1.10	2112	(BE2)32,48 (BE3)17 (BF2)31	65 67 93			8-10	36	WM	
3.1.10	2183	(AB5)1 (AC5)59 (BE2)48 (BF3)59 (HA2)12 -	22 23 67 69 92	850	820ER 825ER	9-11	56	WM	
3.1.10	2505	(AB4)23 (AB5)20 (AB6)1 (AC5)13 (AC6)12,13 (AD5)99 (BF2)51 (CF4)1 (TG5)74,117	22 65 69 93 94 97	850	820ER 825ER 825EW	8-18	182	WM	
3.1.10	2566	(AB5)32,71	65 94			10-11	50	WM	

Fig. no.	Type	Provenance	Fabric	Dec.	Surface treatment	Dia.	%	Man.	Comments
3.1.10	2691	(AB4)11,23,31,33 (AB5)213 (AC5)17,55 (AD5)1 (BD2)94	65 67 69 93	850 x 2	820EW 825EW 825EIW	8-12	405	WM	
3.1.10	2806	(BC3)3 (TG5)1,75	65 80 94L		820EW	9-11	31	WM	
3.1.10	2851	(AB4)20,33 (FQ3)42	65 67 79 94		825EW	8-13	104	WM	
3.1.10	2940	(AB4)33 (AD5)113,127 135,151 (CE5)1 (FN6)9 (FQ3)58 (TG5)1,29- 105,74	23 65 69 80 92 93 94 102 128 130		820EP 820ER 820ECR 820EW 825EW RBR	7-13	122	WM	
3.1.10	3010	(AB5)239 (AC5)49,57 (AD5)21 (TG5)44	94		820ER 820EW 825ER	8.5-10	156	WM	
3.1.10	3306	(AD5)37	65			9.5	100	WM	
3.1.10	3312	(AD5)67	65			9.5	43	WM	
3.1.10	3591a	(TG5)22	-			9	-	WM	
3.1.10	4007	(TG5)87	92C		820EP	10	21	WM	
3.1.10	4011	(TG5)73,91	94		820ER RBR	10-11	84	WM	
3.1.10	4012	(TG5)91	94		820ER BL TOP	11	26	WM	
3.1.10	4013	(TG5)87	69		820ER ribbed	10	22	WM	
3.1.10	4014	(TG5)91	94			-	-	-	
3.1.10	4015	(CF3)1 (TG5)73	67 94		820ER 825EW RBR	8-11	43	WM	
3.1.10	4016	(TG5)73,73-91,94	65 94		820ER RBR	8.5-16	97	WM	
3.1.10	4017	(TG5)73,87,91	94		825ER	9-10	57	WM	
3.1.10	4018	(TG5)73,74,91	65 67 69 92 94		820ER	9-10	89	WM	
3.1.10	4019	(TG5)73,91	94		820ER	9-11	73	WM	
3.1.10	4020	(TG5)87	67		820ER	10	17	WM	
3.1.10	4026	(JE2)2 (TG5)73,91	65 95		825ER	6-10	67	WM	
3.1.10	4030	(TG5)73	94		820ER	11	14	WM	
3.1.10	4152	(FO6)48	113		820EY ribbed	8	23	WM	
3.1.10	4231	(TG5)102	-			9.5	-	WM	
3.1.10	4232	(TG5)102	-			8.5	-	WM	
3.1.10	4245	(TG5)86	94		820ER	7.5	27	WM	
3.1.10	4266	(CF4)1 (TG5)85	93 94		825EIR	11-12	27	WM	
3.1.10	4280	(TG5)4/5,113	94			12	10	WM	
3.1.10	4604	(TG5)4/5	94		825EP	10	19	WM	
3.1.10	4797	(GD3)74 gr. 45	130		825ECR	11	12	WM	
3.1.10	4841	(TG5)74	80		820EW	9	14	WM	

3.2. Imported Amphorae, Napatan jars, Meroitic beer jars and miscellaneous flasks, jugs and bottles

This section begins with the more exotic imported transport amphorae from the Levant and the Mediterranean, followed by Napatan and Meroitic jars. Some of the imported amphorae date to the Meroitic period, but neither in the early nor later Kushite period is there more than a handful of examples that come from even further afield than Egypt. These do not represent a commodity trade in the same way that the Napatan amphorae originating in Egypt do. The Meroitic jars are decorative, red or orange slipped, often with floral decoration, and not really suited for transport. Was there a complete change in the economy in the Meroitic period? It is notable that none of the Nubian jars that date to the Meroitic have handles; these make a return in the Post-Meroitic (but no contexts of this date have been found at Kawa).

3.2.1 Levantine/Canaanite amphorae, a table (?) variant of Dressel 2-4, other amphora rims of Aegean origin (?)

Note that a smaller-scale alabaster copy (*c.* 40cm high) of the Levantine amphorae occurs at Ku.53 (2, 751-716 BC) fig. 29c and pl. 39A1, 19-3-1363. For a partial bibliography of Phoenician/Levantine amphorae, see Heidorn 1994, figs 3.k and 4.a-c. The Levantine amphorae presented here date from the early to mid 6th century BC, and as far as we can tell from the rims and shoulders belong to Bettles' Type A amphorae, especially A2 and A7, which have a capacity of 11-14 litres (Bettles 2003, 105-126 & fig. 4.1). Other publications consulted give slightly different dates (see below). They present a common but not abundant presence at other Napatan sites in Nubia, for example at Sanam (Vincentelli 2018, 132, pl. 9), and are thought to have contained (olive) oil.

+2438x: The best parallel for this unique example at Kawa is a Chian amphora (Heidorn 2018b, 190-91, 3.a, pl. 1.a), dating to *c.* 560-510 BC. It is a little surprising that it is recorded as being made of Fabric 87, as usually this fabric is exclusively linked to the Levantine amphorae. This could be explained by the fabric containing similar inclusions, such as the description of the Chian amphora fabric in Heidorn 2018b. Regardless of the fabric, it is still most likely that the amphora is of East Greek origin (cf. Heidorn 2018b, fig 3.e, f & h). Roberta Tomber (pers. comm.) has suggested a Rhodian origin or an Egyptian copy of Hellenistic date, but the hint of the neck beginning to curve inwards and the fabric make Chian appear a plausible identification. Beg.W.102 (60-70? AD 167-317) fig. L5, 22-1-56; Beg.N.11 (36, 186-177 BC) fig. 44, 21-3-460a; Bar.6 (44, 56-43 BC) fig. 66, 16-2-371 HRW; Vila 1982, fig. 125.f, Missiminia tomb 2-V-20/281, no date (beyond it being Meroitic) or identification given.

2657xa: Nu.74 (6, 664-653 BC) fig. 16, 18-2-26. Possibly also Mohamed Ahmed 1992, fig. 16 IA10a (7th century BC); Vincentelli 2001, 80, fig. 5.1 (25th Dynasty).

2917x: Form like a Levantine amphora, but the fabric is different (98) – 'clear quartz sand, grey matrix', Fabric 87c,

which has a dark matrix as opposed to the orange of Fabric 87, could have been misidentified as Fabric 98.

+2983x: Aston 1999, pl. 73.2046, 5th to 4th centuries BC; Aston 2007, fig. 12 [2046] from Syria, 550-400 BC, or fig. 11 [1704], 700-600 BC; Ku.52 (3, 716-701 BC) pl. 25A, 19-3-1158 (note new date given on the MFA website: 743-712 BC [acc. no. 21.3237]).

+3792x: An imported jar, of unknown provenance. The fabric is not that of the Phoenician amphorae, and its form is completely different.

+4317x: Base of a Hellenistic (Ptolemaic) Egyptian amphora (Roberta Tomber, pers. comm.). Alternatively, it could belong to a Rhodian amphora of the same period. The fabric is not a marl. The uniqueness of the find and the abraded surfaces do not permit a closer identification.

+4338x: Bar.1 (44i, 43-26 BC) fig. 69, 16-2-285, 'x-ware' (but regular Dressel 2-4 size, although it is not recorded with the characteristic bifid handles). For a summary of Dressel 2-4 amphorae occurring in Nubia (all at the regular size, whereas this is of so-called 'table amphora' size), see Baginska 2005, Type 2, pp. 16-19, 32. The present specimen most likely dates to the first half of the 1st century AD. Its small size in combination with it not having a ring foot, like the table variant example at the British Museum (https://www.britishmuseum.org/collection/object/G_1859-0216-12) is a little problematic, as is its apparent rarity. The fabric is indisputably Campanian, rich in volcanic augite. It has a thin glossy slip, unlike the actual table amphora example.

+4360x: Late Rhodian amphora handle, Camulodunum 184, date range late 1st century BC - early 2nd century AD (Roberta Tomber, pers. comm.).

4439x: Mareotis AE 4? Baginska 2005, 24 Type 7 1st- early 4th centuries AD. Also found in the Kirwan excavations at Kawa in the 1930s (Kirwan 1955, also Laming Macadam 1955 II, pl. XXXII, [2112] and [2156]), 'Meroitic' (*sic*), similar to Dressel 2-4 but made in Egypt).

+4479x: Graeco-Italic amphora rim, from Italy? (Roberta Tomber, pers. comm.).

4487x: The form looks very much like that of a Levantine amphora, but the fabric is not the usual Fabric 87, but rather a very hard Fabric 65 with lime: still of Levantine origin, but from a different production site to the others?

+4728x: Base of a Hellenistic amphora, most likely from the Aegean region (Roberta Tomber, pers. comm.).

3.2.2 Beaded rim, straight neck and ovoid body, medium sized container vessel without handles and round base

All Napatan.

4022x: Nu.3 (8, 643-623 BC) fig. 29, 18-4-155; Nu.9 (11, 568-553 BC) fig. 93, no registration number; Nu.27 (10, 593-568 BC) fig. 84, no number.

+4787x: Height 30.4cm, width 23.7cm. Nu.3 (8, 643-623 BC) fig. 29, 18-4-155, albeit a more elongated profile, such as in 2.2 and 2.3. Note that the same form but with a ring-footed base, occurs in Napatan graves at Missiminia (Vila 1980, fig. 29.8, Type II-1C fig. 171; Griffith 1922, 81, pl. XXI.1, in a foundation deposit of the temple at Sanam

Abu Dom. At Kawa the form was also found in a Napatan period grave, (GD3)98.

3.2.3

As 3.2.2, including a plainer variant (3668x) of the same form, as well as two miscellaneous neck/shoulder sherds, probably of Meroitic flagons, with flanged or beaded rims and straight, narrow necks.

2784x: Beg.W.139 (50-55, AD 25-115) fig. K1, 22-2-291.

4025x: Mohamed Ahmed 1992, fig. 25 II A17a (late 6th-early 5th centuries BC).

3.2.4 Meroitic jars

Bulbous body, straight neck and beaded rim. Red or orange slip, undecorated or with painted bands, orange slip.

+4327x: Bates and Dunham 1927, pl. LXII fig. 20 Gemai, T 10, 1 and 2.

3.2.5

As 3.2.4, but neck increasingly more inward sloping rather than straight. Decoration consists of painted dark band at shoulder/neck join and symbols: a grille within a circle (+4329x) or alternatively a wheel motif (3694x, 4329x [3.2.5] and 3695x [3.2.6]) and a *Tyet*-tie motif, 1291y and 1289y respectively (see Näser 2004, 242, fig. 109 and alternatively Török 1997, *passim* where the same is called an ‘*ankh-sa*’ motif). Note that Török describes this as a double-linked *ankh*, but regardless what we call the symbol it is the same. See further: Török 1987, 99 & fig. 18; 1990, 239, no. 358, 1st century BC. Also at Faras, Griffith 1925, pl. XXV.2.

3694x: Griffith 1925, pl. 25.2, jar from the Meroitic cemetery at Faras (grave 2382). Rose 1998, 143, fig. 6.5 <1101>, <1102> and <1105> from Gabati. Note that, intriguingly, the same decorative arrangement is also found in Structure M195 at Meroe, as architectural decoration (Török 1997, I, 76, II pls 30, 32 & 33). Exactly what this means, whether the architectural motifs were well known and inspired the potters or whether they were simply popular motifs at the time, is not clear. Structure M195, part of the Water Sanctuary complex at Meroe, is dated to early 3rd century BC, with a second phase in the later 1st century BC-early 1st century AD (Török 1997, I, 70-71); at any rate, it falls within the date range of the jars.

3.2.6

As 3.2.5 as well as jars with sloping neck and plain rim, shoulder increasingly less pronounced. An example from Kerma, about half-way between +4330x and +4551x (but wheel-made) has been roughly dated to 1st century BC-1st century AD (Bonnet and el-Tayeb 1991, 32, 34, fig. 4).

+2881x: Beg.N.20 (39, 133-116 BC) fig. 50, 21-12-197 RBW; Beg.N.21 (40, 116-99 BC) fig. 55, 22-1-123, neck a little longer.

3695x: Form and decoration as for 3694x above.

+4330x: Bates and Dunham 1927, pl. LXII fig. 27, Gemai Gr. 115, similar in form and also with Meroitic graffiti on

the shoulder. Also *ibid*, pl. XXVI fig. 4a, Gr. 119.

+4551x: Beg.W.458 (55-65? AD 93-246) fig. J11, 23-3-456; Beg.N.8 (35, 203-186 BC) fig. 41, 21-12-92 HBKW; Beg.N.29 (59, AD 150-167) fig. 111, 21-3-148 (but polished black ware); very similar to Bashir and David 2015, 101 & fig. 7, B23-285, preliminarily dated to the 2nd-early 3rd centuries AD.

3.2.7 Neck sloping straight into shoulder without a neck as such, a common Meroitic type

4459x: Beg.N.8 (35, 203-186 BC) fig. 41, 22-1-10 for the form only, not the decoration.

+4803x: Height 31.6cm, width 28.7cm.

+4804x: Height 34.8cm, width 29.5cm. The lower third of the exterior surface is worn, so the vessel is likely to have been in use before interment. Bonnet and el-Tayeb 1991, fig. 4, same form and wall thickness, but devoid of decoration.

3.2.8 Tall ovoid jars

Made in three parts, with straight neck/rim and sloping shoulders.

+3538x: This type of large piriform jar, together with +4786x (3.2.9) are thought to date from between the 1st and the 3rd centuries AD (Malykh 2017, 193, with further bibliography), but see below (4786x) for a possible continuation into the Post-Meroitic. According to Bashir and David (2015, 101 & table 1) this type also ranges between the second half of the 1st and the early 3rd centuries AD.

3543x: Beg.N.5 (50, AD 25-41) fig. 84, 21-12-65b RBW.

3.2.9 Another variant of 2.8; nearly complete krater and similar rims

+4786x: Beg.N.19 (61, AD 184-201) fig. 116, 21-3-301a; Beg.W.109 (60-70, AD 167-317), fig. L8, 22-1-541; Beg.N.30 (60, AD 167-184) fig. 113 21-3-306 CRW; Török 1997, fig. 144.32, Post-Meroitic (?). Reisner 1923, fig. 19.53 (excavations at Kerma) albeit with more pronounced shoulder and bulging in towards the base below. This jar also has a graffito similar to 225g (G8). On the whole, the dating proposed by Bashir and David (2011, fig. 5) of the 2nd to 3rd centuries AD seems the most probable.

+4810x: Nearly complete *krater* profile, but missing the base and both handles, with grille and floral pattern decoration. Evina 2018, 234-35, 3rd-2nd centuries BC? Certainly pre 1st century AD; Török 1997 II fig. 69 98-3 and fig. 101 295-5 (handmade).

3.2.10 Globular jars and a flagon

Globular jars with narrow, vertical necks of various types; a two-handled flagon, probably imported, two also globular, medium-sized jars with no neck to speak of and a slipped body decorated with red and brown/black bands. Meroitic.

2874x: Ku.T4 (860-840 BC) fig. 3a, 19-3-409, red ware; Beg.W.162 (45-55? 43 BC - AD 115) fig. D6, 32-1-48h. However, see also Aston 1999, pl. 90.2410, 4th century BC.

3558x: Same ware and fabric as 3579x (3.2.7); what appears to be a close parallel is found in Bar.1 (44i, 43-26 BC), fig. 135, Barkal pottery type XVIII-I 16-2-283, polished red/

brown ware. See Vila 1967, fig. 172a (Aksha grave AM 50), a Meroitic burial. The form is similar, but in Vila the vessel is decorated with two black horizontal bands; no suggestion as to provenance.

+4333x: Beg.W.284 fig. G18, 23-1-248, 1st-2nd centuries AD; now at the MFA, acc. no. 24.1468; the form and decoration is almost identical, except for a motif on the base and being much smaller in size (10.7 x 11cm) than our example. Woolley and Randall-MacIver 1910 IV, pl. 79, 8279 (Gr. 755), but at Karanog with an additional decorative band above the ivy motif. The overall date of the Karanog example is 2nd to 5th centuries AD.

4486x: Rim has been ground down, to repair a break?

+4653x: Williams 1985, fig. 18a and b, Qustul burial Q402, also with a glossy red exterior, but lacking the shallow bands of ribbing at Kawa. Meroitic, phase IIIb at Qustul (essentially the 1st to 2nd centuries AD). In terms of ware, it looks similar to 3558x.

+4802x: Height 27.8cm, width 23.9cm. Bates and Dunham 1927, pl. LXI, fig. 32 E85; MFA, Kerma Meroitic cemetery, grave 17, acc. no. 20.4038; Török 1997, fig. 144.31, Post-Meroitic?

3.2.11 Jugs, flagons, pilgrim bottles, *clepsydra*(?), an *unguentarium* and flasks.

One and two handled jugs, flagons and other narrow necked forms with everted rims; pilgrim bottles, bottle without handles, possible *clepsydra* rims, an *unguentarium* and various types of narrow everted necks of flasks or similar.

424x: Beg.W.778 (3-9, 716-593 BC) fig. 183.9; Beg.W.852 (3-9, 716-593 BC) fig. 185.11; Aston 1999, pl. 55.1689, mid 8th to 7th centuries BC, rim a little different but same type of vessel. Vila 1980, fig. 139.1

2491x: Note similar form, 4318x (12.4), handle only, without the rim.

+2531x: Mohamed Ahmed 1992, pl. 3, fig. 18 1C1a, 1C1b, phase two, late 7th to mid 6th centuries BC.

2854x: Boulet 2017, fig. 2.v (25th Dynasty); Boulet 2018b, fig. 4.d, Theban phase two, late 8th to early 7th centuries BC.

+2847x: Williams 1990, pl. 8b, cemetery VH near Qustul, grave VH 111; see also Griffith 1923, pl. XVII, VIIc; Vila 1980, fig. 130.5 and fig. 176 type II-5, 314/7. Note that in the latter instance the handleless flask was found together with a pilgrim flask closely resembling +4784x and a tall necked beaded jar like 4787x (2.3), only more elongated, as well as a number of red-slipped beakers, such as those represented in 3.10.3.

2999x and similar: Jug necks, cf. more elaborate version from Ku.2 (24, 362-342 BC) fig. 9a, not registered; Vila 1980, fig. 17.4 and fig. 142.3, type II-3.

3168x: A Meroitic *clepsydra* rim? cf. Devries 1973, fig. 3; Hoffmann 1994, fig. 6. No base of a *clepsydra* has however been found in the course of the current excavations.

+3693x: This type of *unguentarium* dates from the second half of the 1st century BC to the end of the 1st century AD (Anderson-Stojanovic 1987, 110, figs 1 and 7). Height 11.6cm, base diameter 2.6cm, rim diameter 2.5cm, opening 2cm. The same form occurs across the eastern Mediterranean, for example at Stratonikeia (ancient Caria) in western Turkey (Baldiran 1998, 359, 39), and at Kourion

on Cyprus (McFadden 1946, 480, pl. XLII 73 & 74), the general form being ubiquitous as a grave good in the Hellenistic and Roman periods throughout the Classical world. The only examples of this kind of vessel were found in the same grave, one complete and the other just a neck and rim.

4097x: Ku.52 (3, 716-701 BC) fig. 28c, pl. 43 19-3-1054 Dbw; Vila 1980, fig. 91.3, type III-1B (but if so the base of 4097x, 4098x, is different, or wrongly associated, despite being of the same unusual fabric); Vincentelli 2001, fig. 5.d.

4166x: Laming Macadam 1955 II, pl. XXXII.3 [2052], Napatan.

4505x: David 2018, 278 fig. 13, North African amphora rim (an imitation of a Gallic Dressel 30), dating from the mid 2nd century AD. Found at Sedeinga; see also Baginska 2016, type 11.

4568x: Boulet 2018b, fig. 4.c, Theban production, phase 2, late 8th to early 7th centuries BC.

4619x: see 3168x above. Fabric has poorly mixed kaolin.

+4784x: Small pilgrim flask, a common component of Napatan grave goods. Ku.54 (2, 751-716 BC) fig. 30b, 19-2-1414 fine red ware; Ku.72 (4, 701-690 BC) fig. 35c, 19-3-522; Beg.W.503 (3-4, 716-690 BC) fig. A.31; Beg.W.698, MFA acc. no. 24.3253, identical to 4784x, but dated as Meroitic;¹ Nu.3 (8, 643-623 BC) fig. 28, 17-2-1861; Nu.6 (9, 623-593 BC) fig. 38, 17-1-739, red ware; Nu.21 (9? 623-593 BC) fig. 42, 17-1-631; Vila 1980, fig. II-5. Williams 1990, fig.9b and pl. 8a, cemetery W1 near Qustul, grave W43; Vincentelli 2006, fig. 2.28 162, Hillat el-Arab tomb ARA 8, 25th Dynasty.

3.2.12 Everted jar or possibly amphora rims; juglets or closed jars; closed jar forms with beaded rims

The closed jar forms are similar to 18th or 19th Dynasty storage jars.

2121x: Beg.N.37 (63, AD 205-214) fig. 118, 22-1-33c.

2141x: cf. also 2202x (2.11); Nu.10 (14, 533-513 BC) fig. 118, 17-4-719.

2815x: Beg.N.20 (39, 133-116 BC) fig. 50, 21-12-110.

3188x: Beg.N.8 (35, 203-186 BC) fig. 41, 21-12-182 RBW; however, Mohamed Ahmed 1992, fig. 16 1A12b, late 7th to mid 6th centuries BC.

3590x: Bar.4 (41, 99-84 BC), fig. 58, 16-2-340.

4039x: Note similarity with 2864x (3.5.2).

4392x: Vincentelli 2006, fig. 2.80 518 Hillat el-Arab, ARA 18, probably 19th Dynasty, although the tomb contains later material as well.

¹ The grave number listed in its online catalogue is possibly a mistake, and it's actually from W.503, as the published drawing and modern photograph appear to be of the same object. Alternatively, a mistake in the publication has been rectified?

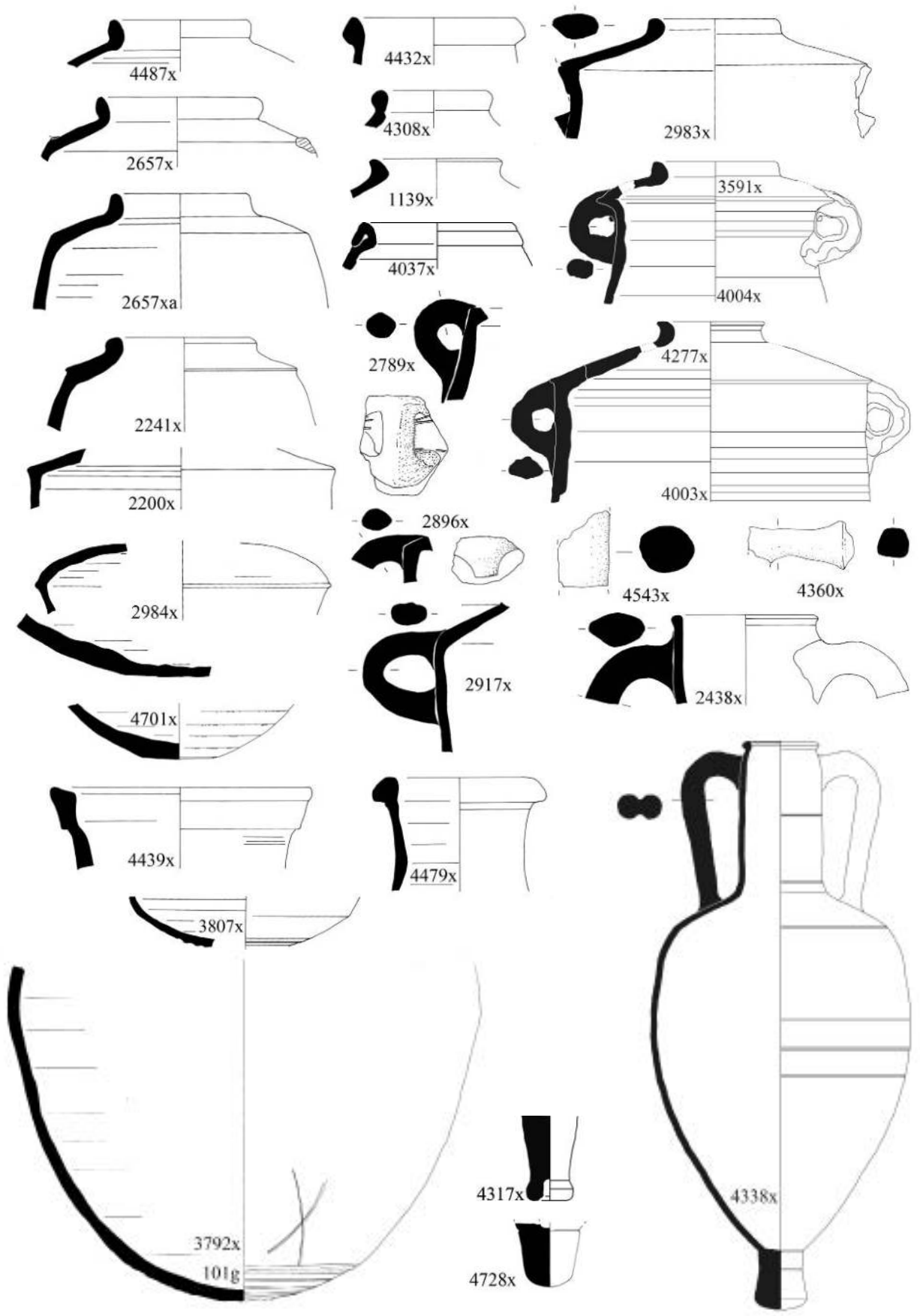

Figure 3.2.1. Imported amphorae, from Egypt and beyond: Levantine/Canaanite amphorae, rim of an Aegean amphora and a Dressel 2-4, table variant (scale 1:4).

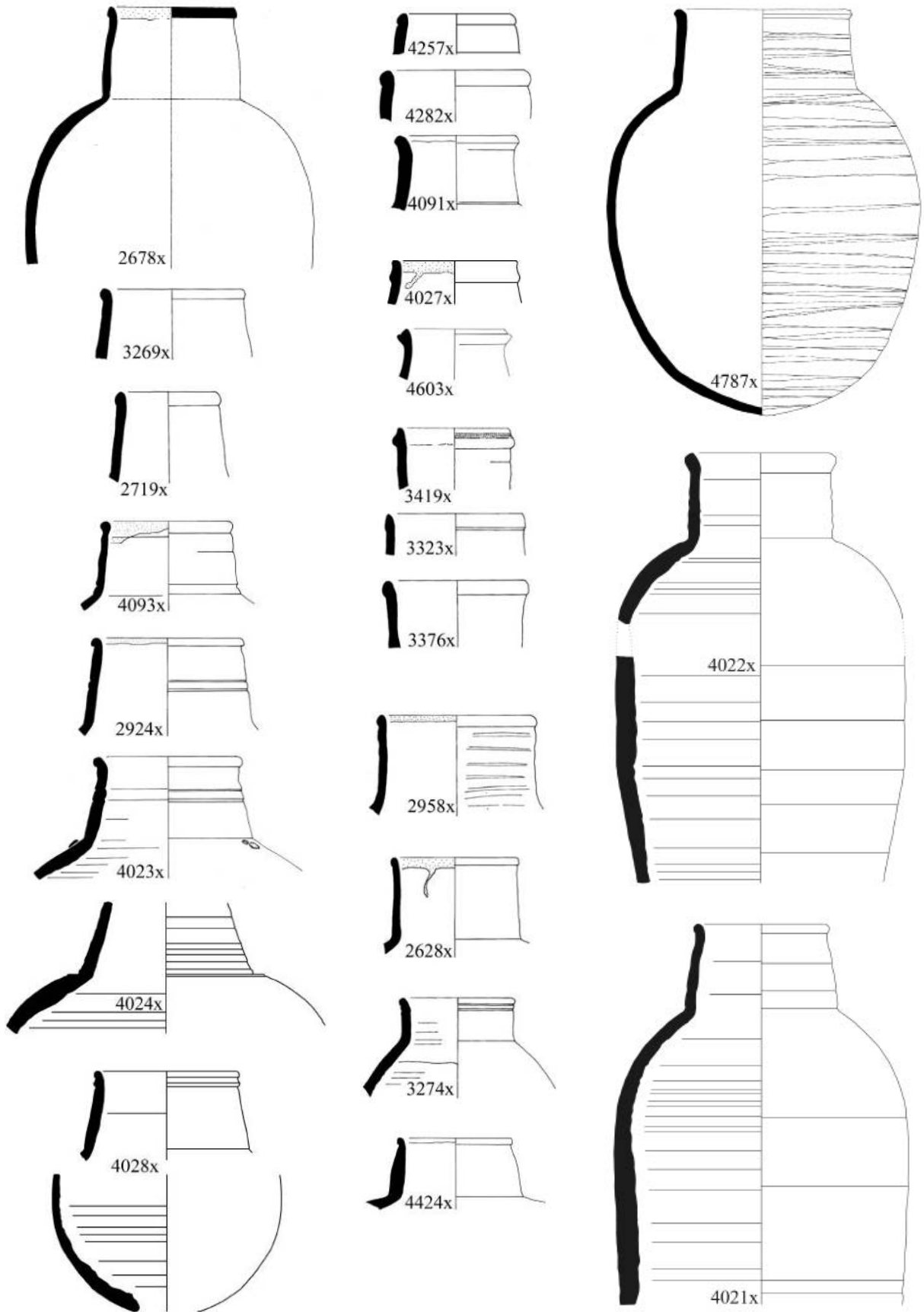

Figure 3.2.2. Jars with beaded rims and narrow necks, narrow diameter at shoulder (scale 1:4).

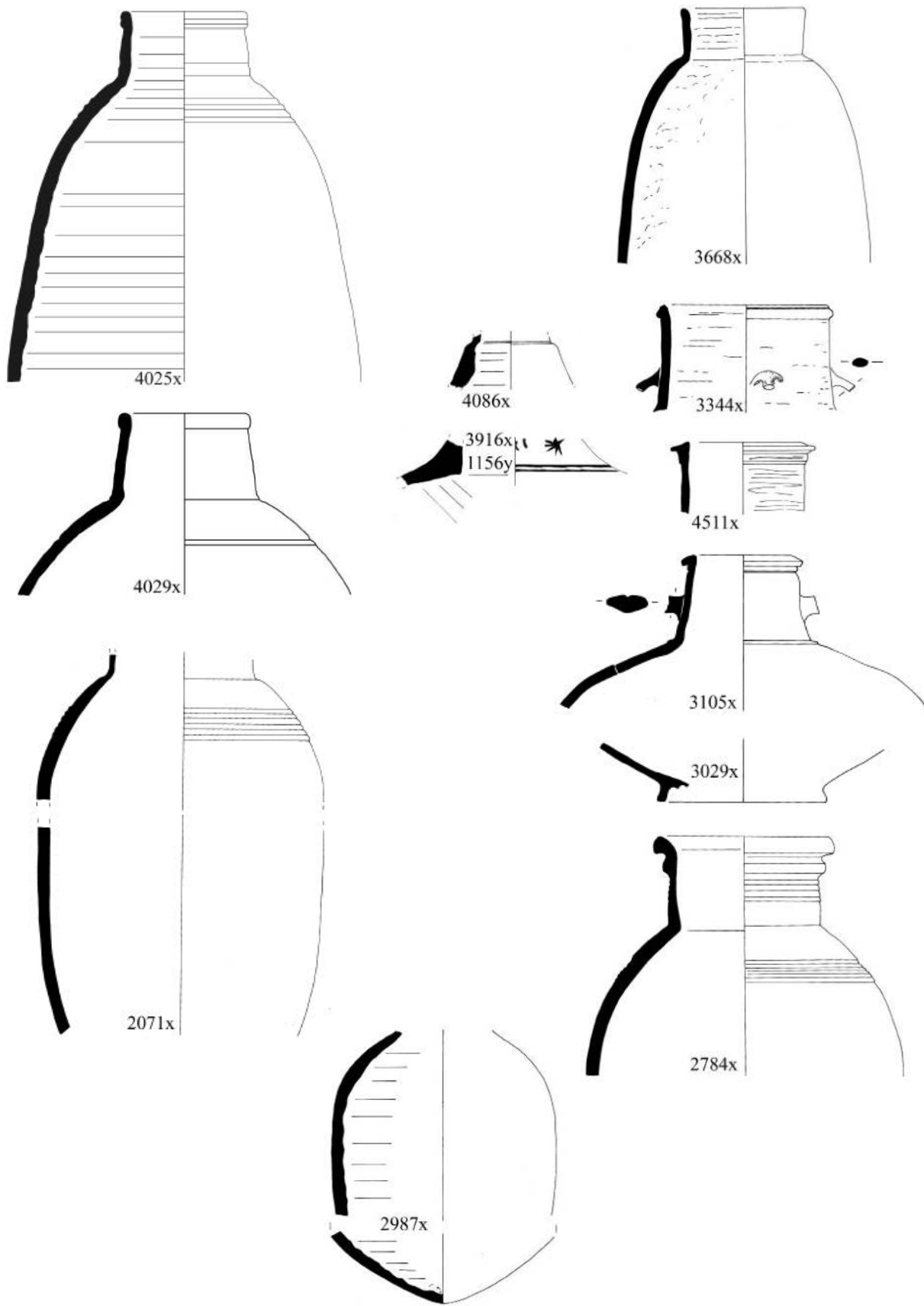

Figure 3.2.3. Beaded, narrow-necked jars, continued; miscellaneous flagnons and jars with flanged, complex and plain rims (scale 1:4).

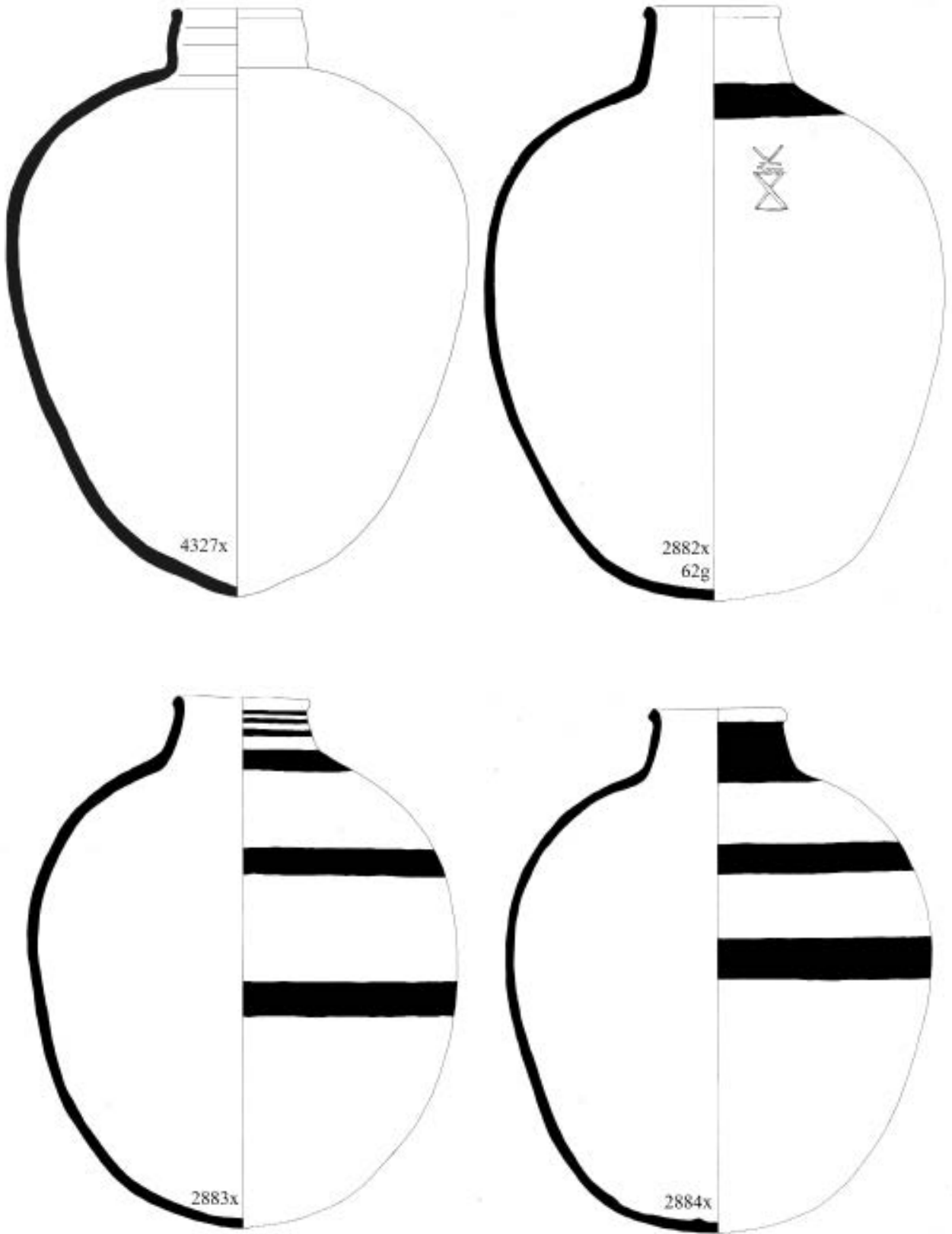

Figure 3.2.4. Beer jars with beaded rims, some with painted bands (scale 1:4).

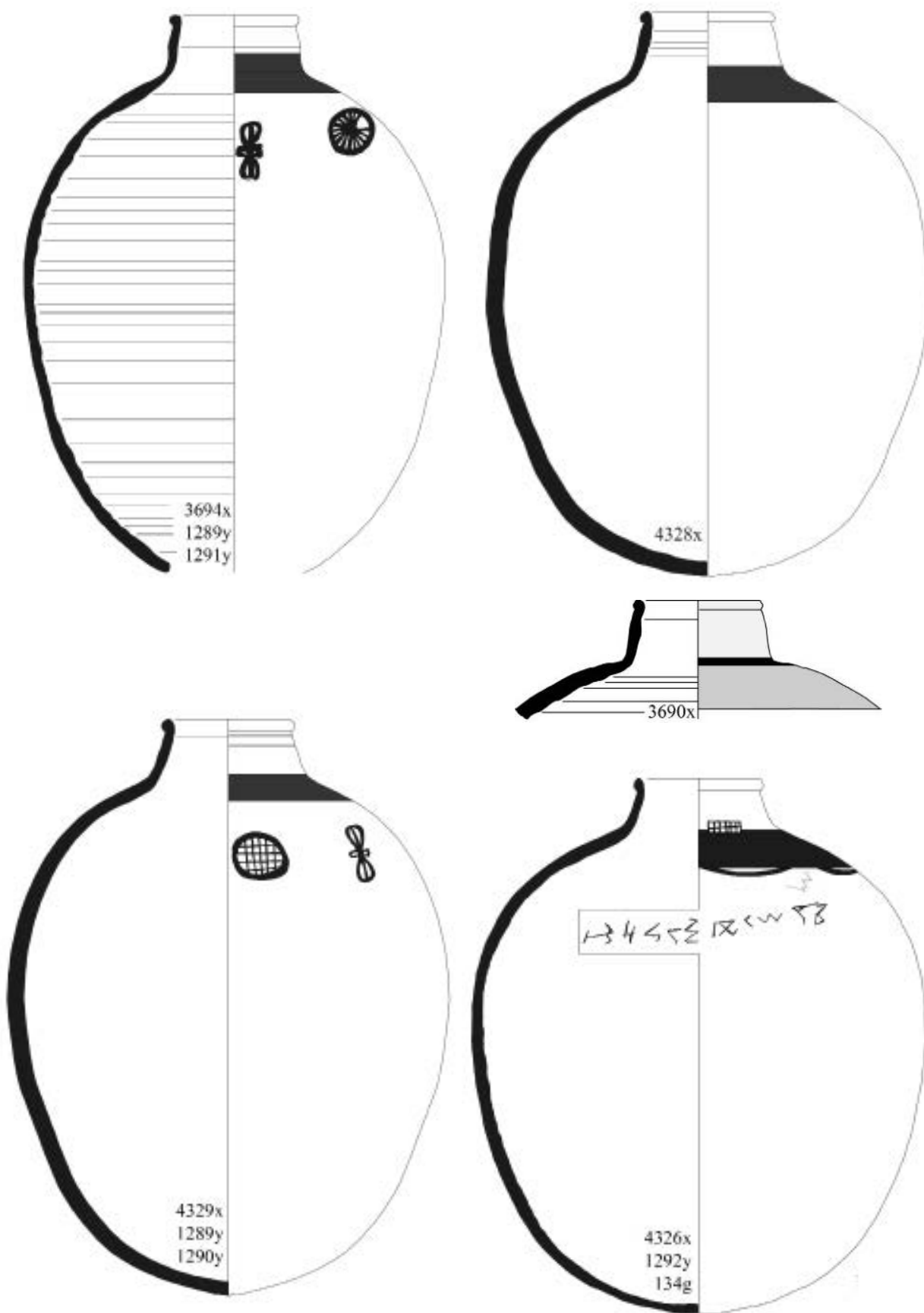

Figure 3.2.5. Beer jars with beaded rims, slipped and with painted decoration (scale 1:4).

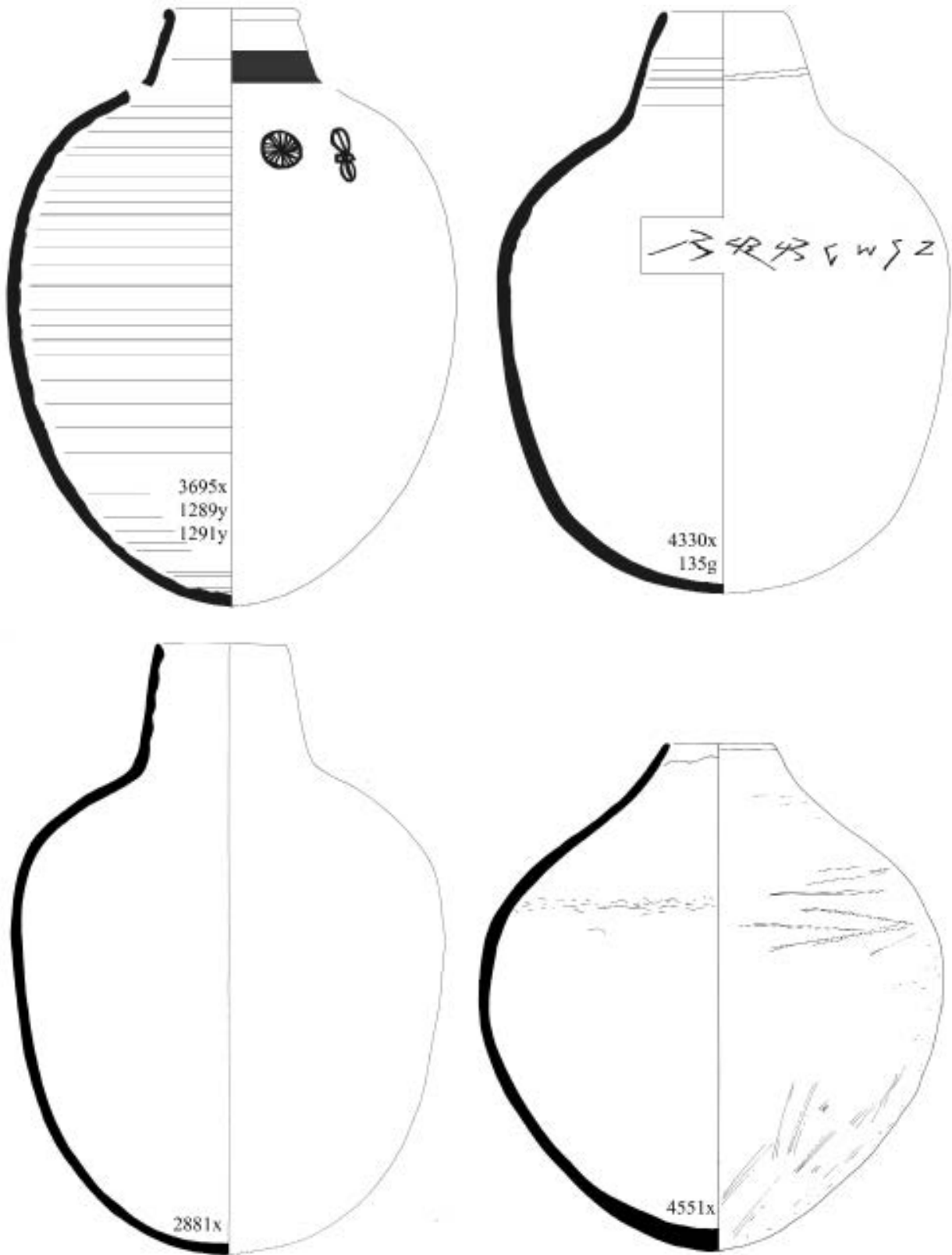

Figure 3.2.6. Beer jars with beaded and plain rims, shoulder increasingly less pronounced (scale 1:4).

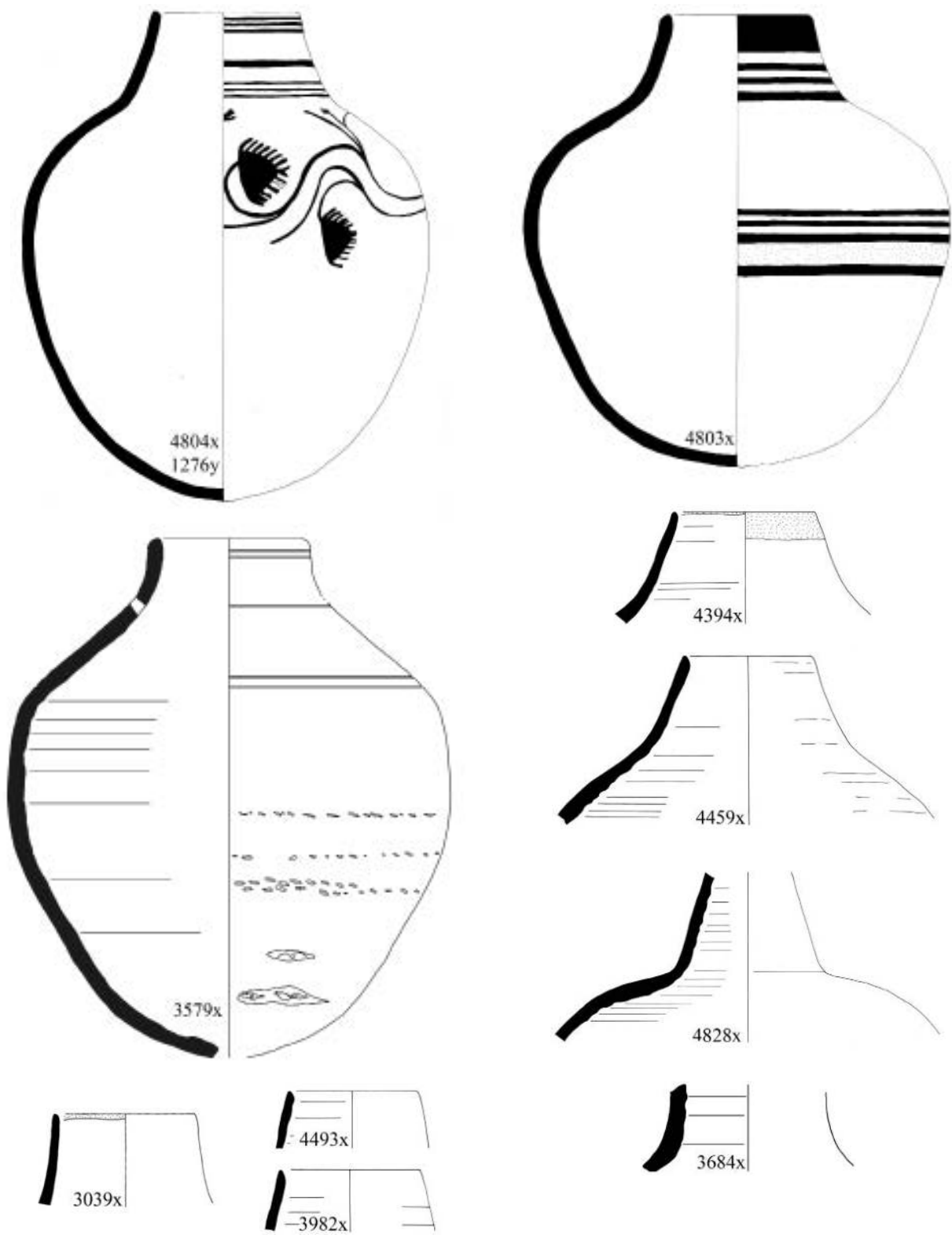

Figure 3.2.7. Beer jars with rim sloping into shoulder (scale 1:4).

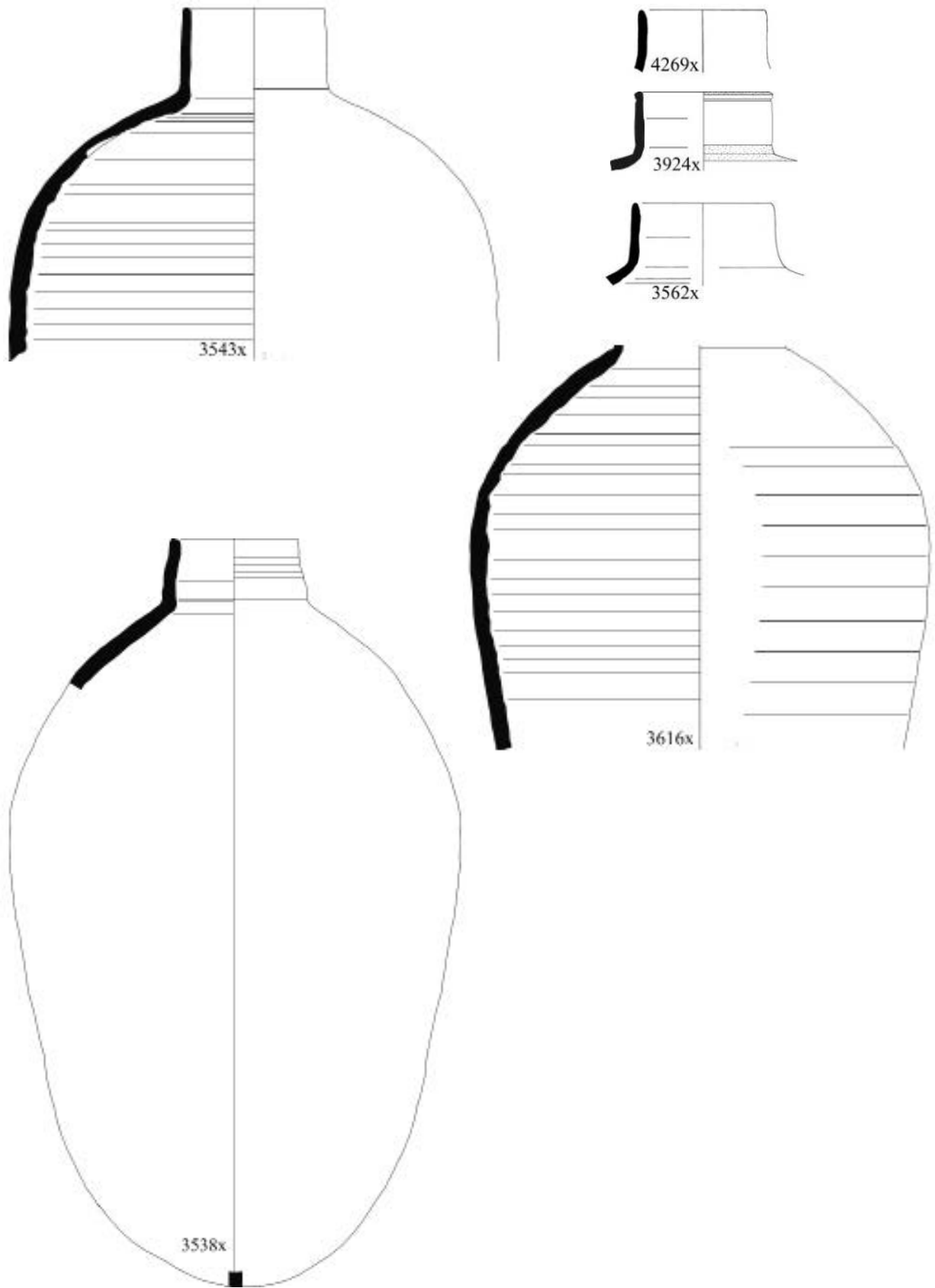

Figure 3.2.8. Ovoid storage jars with sloping shoulders and narrow, straight necks (scale 1:4).

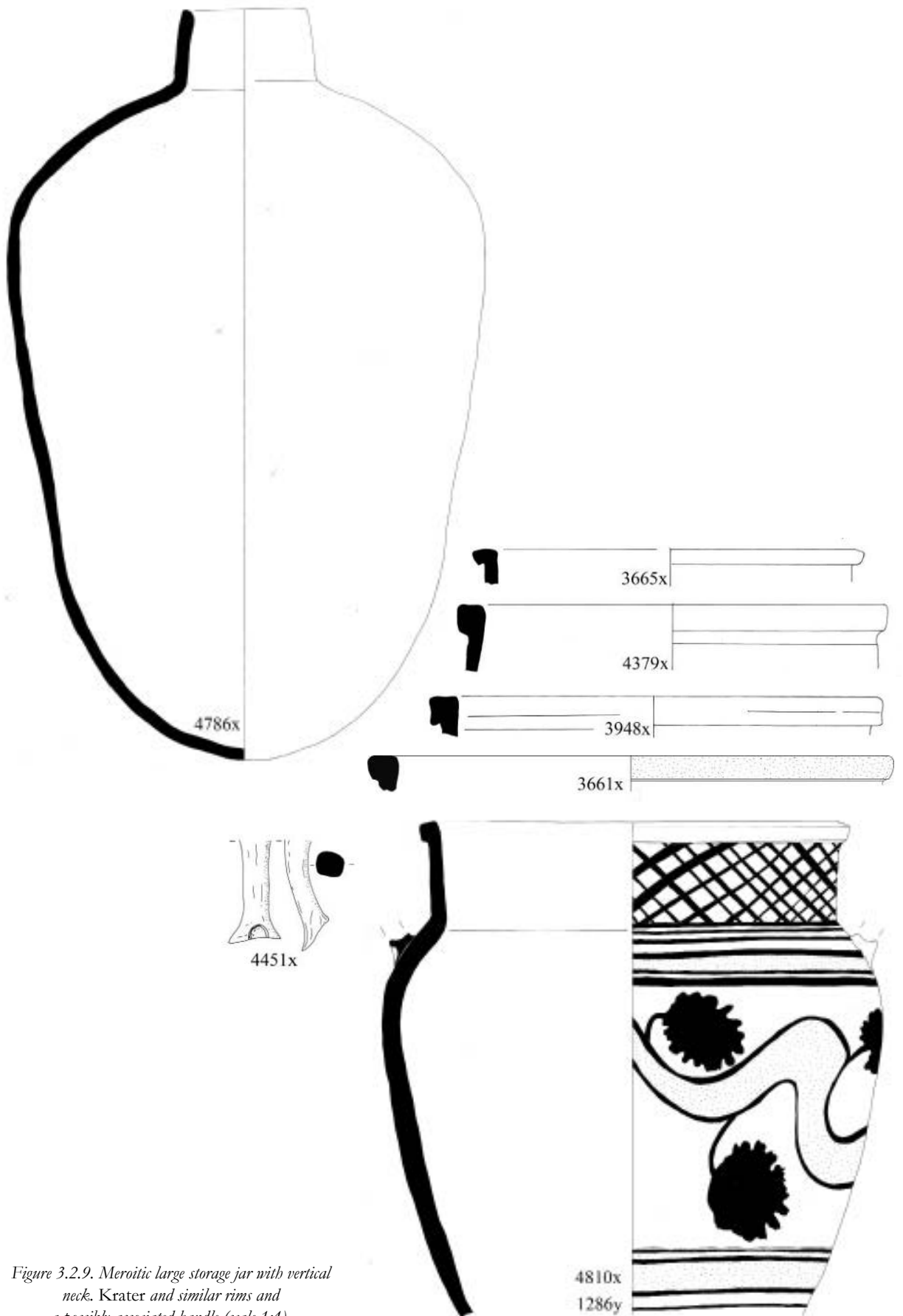

Figure 3.2.9. Meroitic large storage jar with vertical neck. Krater and similar rims and a possibly associated handle (scale 1:4).

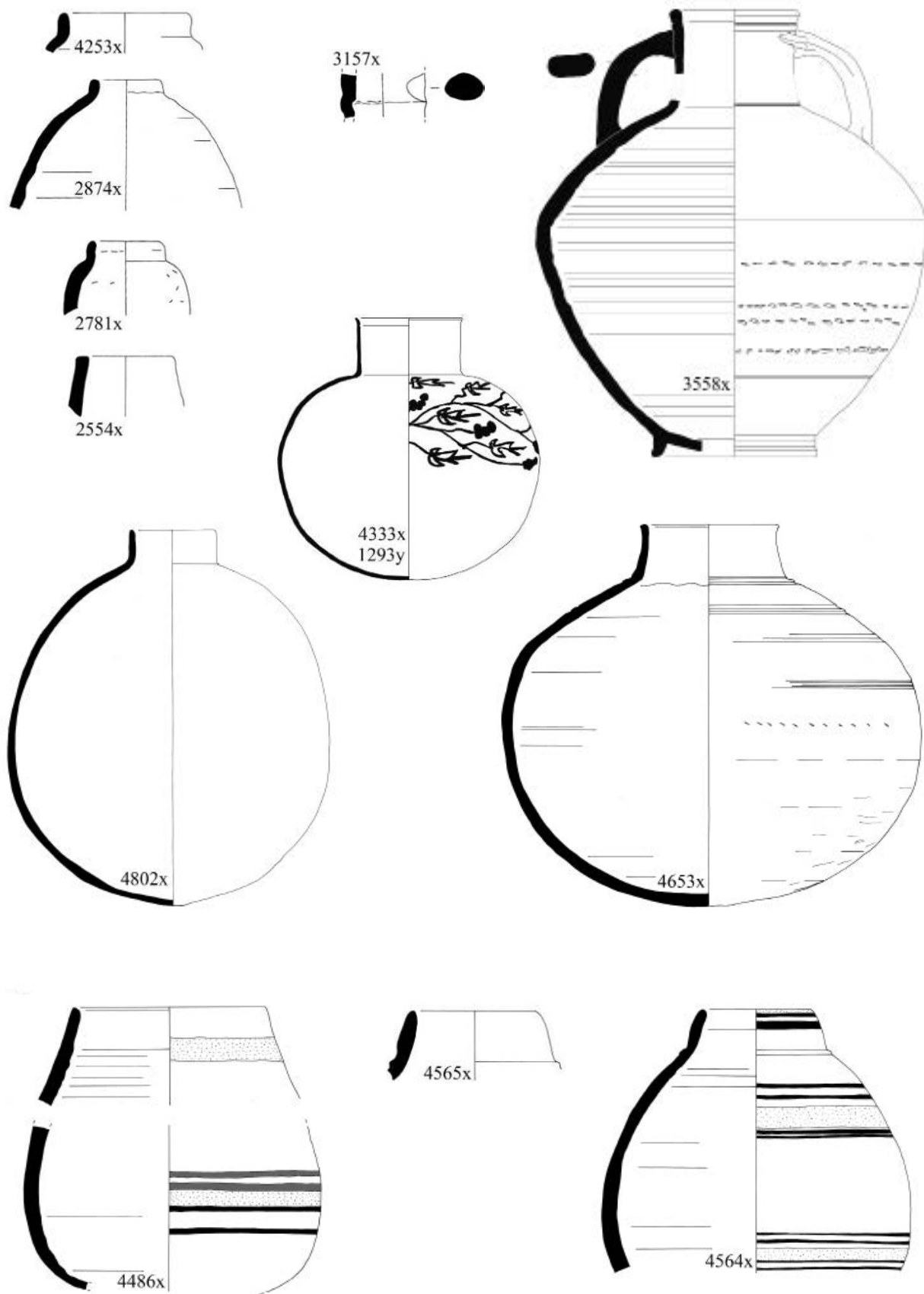

Figure 3.2.10. Globular jars with vertical narrow necks, globular painted jars and a 2-handled flagon (scale 1:4).

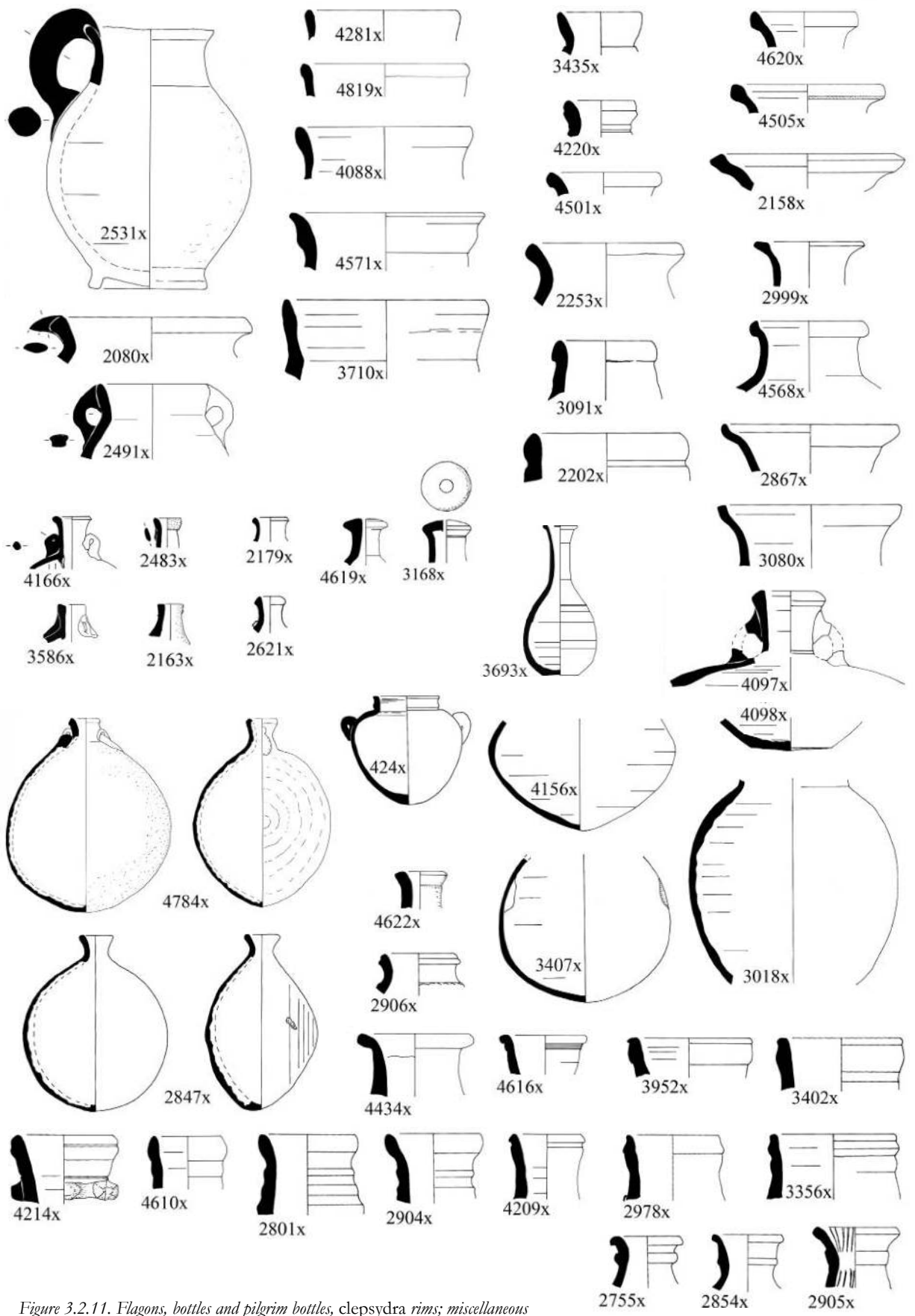

Figure 3.2.11. Flasks, bottles and pilgrim bottles, clepsydra rims; miscellaneous beaded and/or everted rims (scale 1:4).

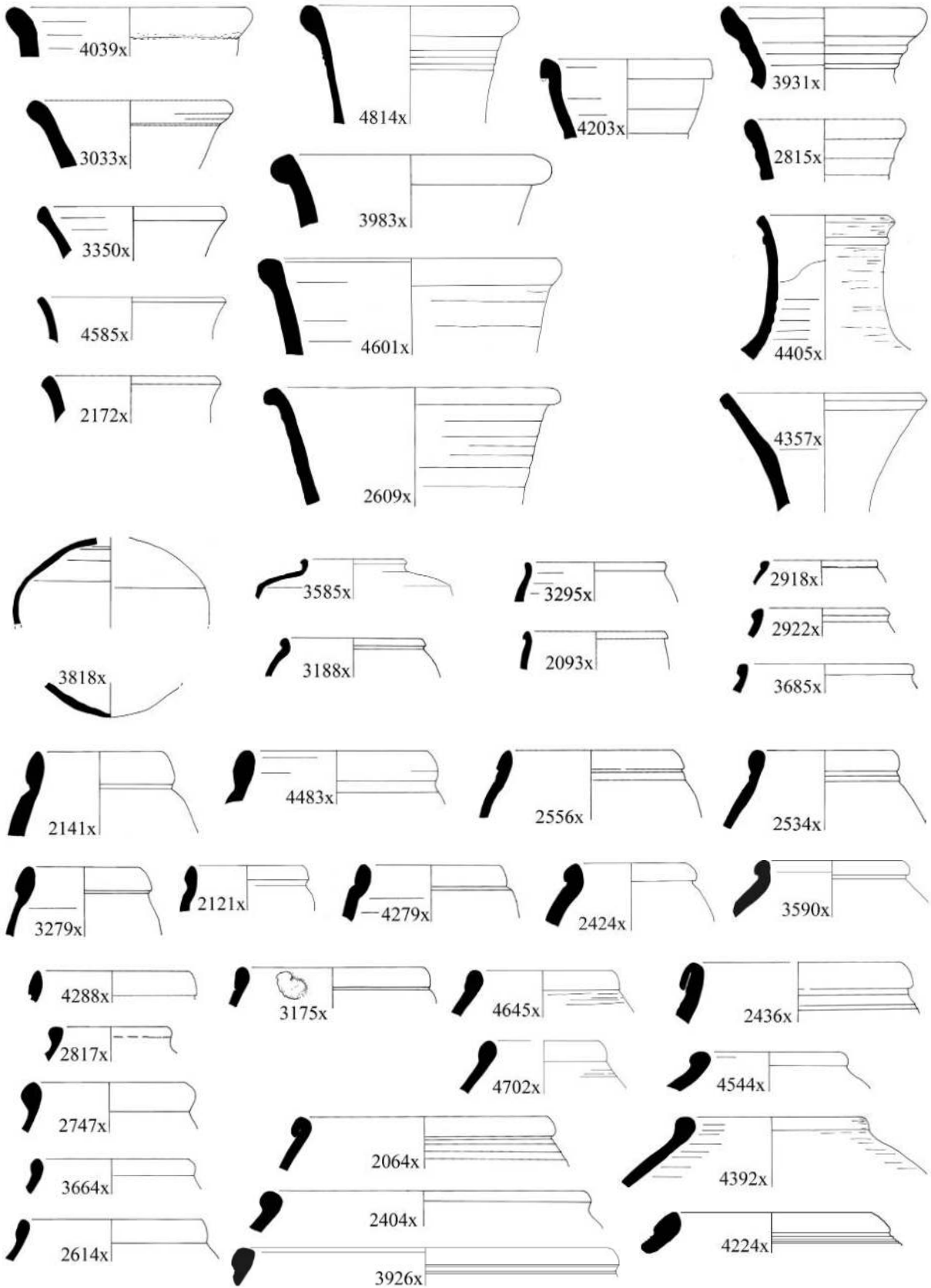

Figure 3.2.12. Everted amphora rims, beaded jug rims and small to medium restricted vessels with beaded rims (scale 1:4).

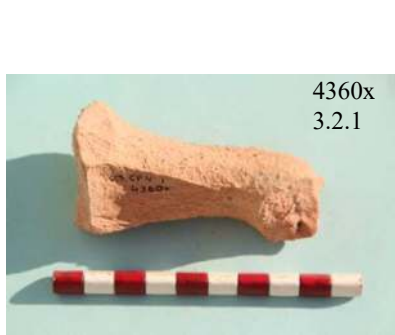
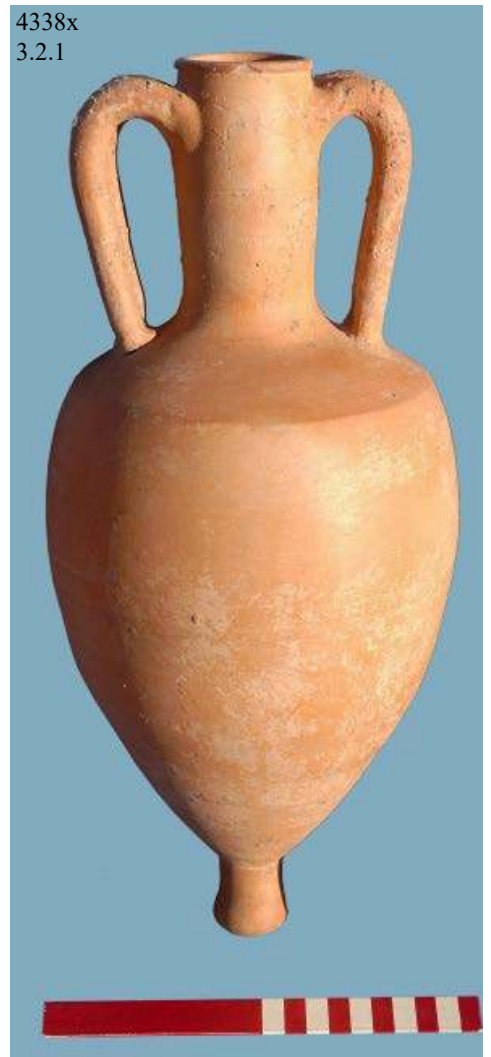
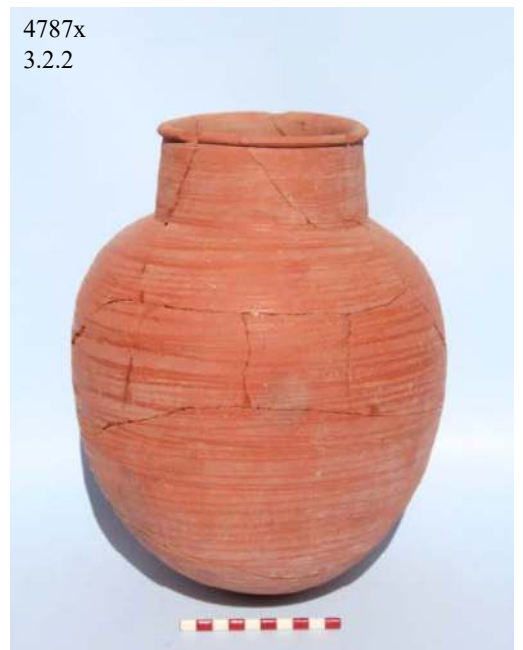

Plate 3.2.1. Imported amphorae and a red-slipped Napatan jar with a beaded rim.



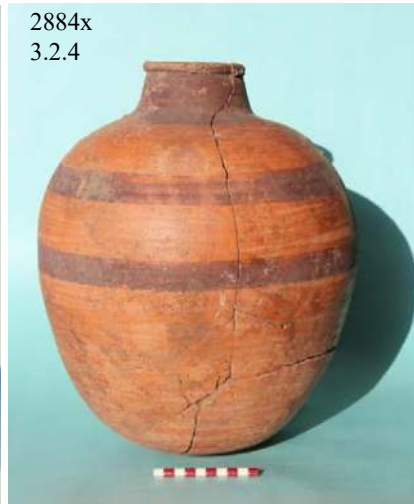
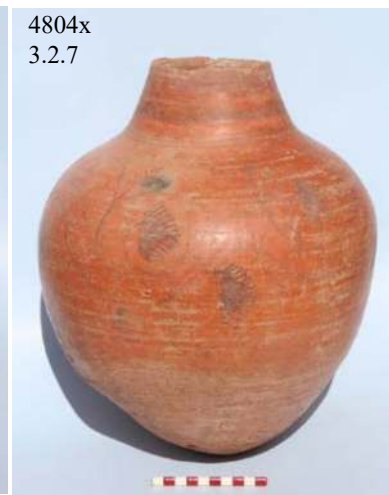
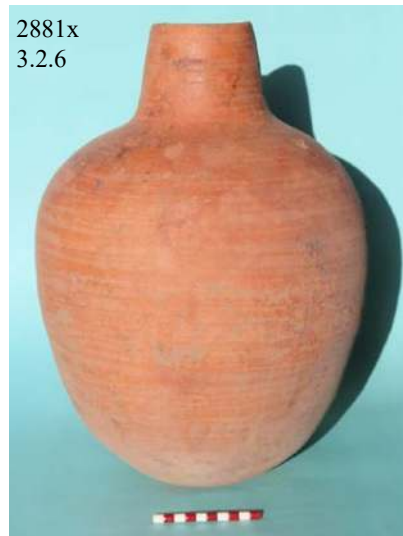

Plate 3.2.2.
Meroitic beer jars.





*Plate 3.2.3.
Meroitic jars.*

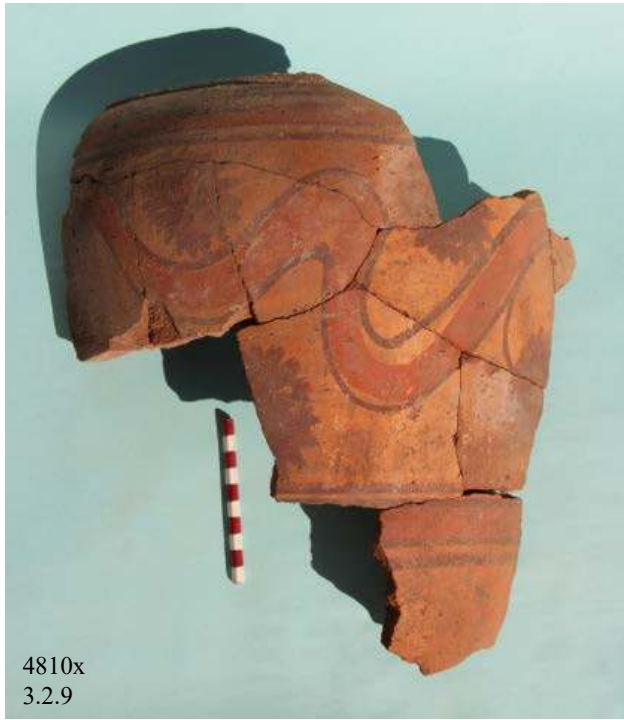
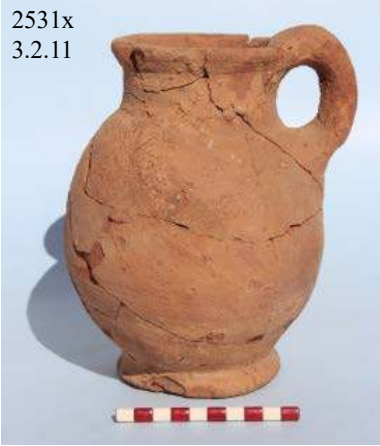

Plate 3.2.4. The painted body of the krater, and various narrow-necked Meroitic jars.

2531x
3.2.11



2847x
3.2.11



3693x
3.2.11

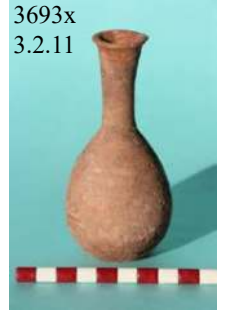

4784x
3.2.11

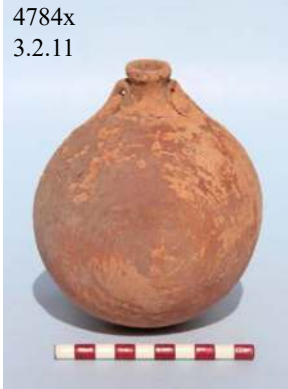

Plate 3.2.5. A jug, a pilgrim bottle, a bottle and an (imported) unguentarium.

TABLE 3.2. IMPORTED AMPHORAE, NAPATAN JARS, MEROITIC BEER JARS AND MISCELLANEOUS FLASKS, JUGS AND BOTTLES.

Fig. no.	Type	Provenance	Fabric	Dec.	Surface treatment	Dia.	%	Man.	Comments
3.2.1	1139	(BE1)1 (BE2)1 (BE4)15	69 87 94		820E	8-18	48	WM	
3.2.1	2200	(AB5)80 (BE1)73 (BF3)8 (TG5)0	77 87 92F		822O	18-23	32	WM	
3.2.1	2241	(BE3)1,16 (BF3)38	61 69 96		825E 832W	10-18	46	WM	
3.2.1	+2438	(BE3)10	87			11	24	WM	
3.2.1	2657	(AB4)23,31 (JD2)49 (nr M9)	87 87C			10-11	48	WM	
3.2.1	2657a	(AB4)7,10	23 32		825EW	9-10	56	WM	
3.2.1	2789	(AB6)16 (BD2)32	67 87		820EW	27x18 23x18	200	WM	
3.2.1	2896	(BD2)101	87					WM	
3.2.1	2917	(AB4)20	98					WM	
3.2.1	+2983	(AB4)23 (AD5)157,164	87			9	62	WM	
3.2.1	2984	(AB4)23	87			-	-	WM	
3.2.1	3591	(B6)7 (TG5)22	87			8-9	22	WM	
3.2.1	+3792	(AD5)273	125	101g	820EPL	35	80	WM	CR interior
3.2.1	3807	(AD5)272	125		825EPL	-	15	WM	
3.2.1	4003	(TG5)73	87			-	-	WM	
3.2.1	4004	(TG5)91	87		820EY	-	-	WM	
3.2.1	4037	(TG5)73 87	87		ribbed	14	32	WM	OF
3.2.1	4277	(TG5)77	87C		825EP	10	12	WM	
3.2.1	4308	(TG5)74	87			9	20	WM	
3.2.1	+4317	(CF4)1 (TG5)1	78F 110			-	200	WM	
3.2.1	+4338	(JG2)2 gr. 2	142		820EO	4.7	100	WM	
3.2.1	+4360	(CF4)1	140					WM	
3.2.1	4432	(TG5)1	87			12	8	WM	
3.2.1	4439	(JD2)18,51 (JG2)202 gr. 175	67 106			13-19	33	WM	
3.2.1	+4479	(CF4)73	-			9	26	WM	
3.2.1	4487	(CF4)96	65L			10	31	WM	
3.2.1	4543	(CF4)108	87C			30x41		WM	
3.2.1	4701	(FP6)109	87C		825ER	6	60	WM	
3.2.1	+4728	(CF4)96	13			5	100	WM	
3.2.2	2628	(AB5)66	65		820EP	9	13	WM	
3.2.2	2678	(AB4)10	92		825EI BL R TOP?	9.5	32	WM	
3.2.2	2719	(AD5)207 (BD2)29,65 (BE1)49	25 67 80 92		825ER	7-10	70	HM WM	
3.2.2	2924	(AB4)22	65	700E		10.5	100	WM	
3.2.2	2958	(AB4)23	69		800E	11	55	WM	
3.2.2	3269	(AC5)37 (FP7)2 (TG5)4	94		820ER	7-10	94	WM	
3.2.2	3274	(AC5)38	94		H820ER	8	10	WM	
3.2.2	3323	(AC5)51	94		825EIW	10	10	WM	
3.2.2	3376	(AC5)39 (BF3)50	-		822R	10-16	20	WM	
3.2.2	3419	(AC5)68 (CF4)20,51 (TG5)86	92 94 108 115		820ER 820EW	7-13	52	WM	
3.2.2	4021	(TG5)73,87,91	65 67 92 94		820ER RBR	9-11	178	WM	
3.2.2	4022	(TG5)73,87,91	92 94		820ER RBR	9-10	21	WM	
3.2.2	4023	(TG5)73,91	65 67 94		820ER RBR	10	101	WM	
3.2.2	4024	(TG5)73	67		820EP/Y	9	28	WM	
3.2.2	4027	(CF5)1 (TG5)87	92 94		800E RBR	9-11	23	WM	
3.2.2	4028	(TG5)73,87,91	94		800E 820ER RBR	9-10	19	WM	
3.2.2	4091	(TG5)94	-			8	-	WM	
3.2.2	4093	(BF3)9 (TG5)94	92			9-12	12	WM	
3.2.2	4257	(TG5)104	94			10	12	WM	
3.2.2	4282	(TG5)109	94		820EW 820IR	10	10	WM	
3.2.2	4424	(TG5)6	100		820ER	8	13	WM	

Fig. no.	Type	Provenance	Fabric	Dec.	Surface treatment	Dia.	%	Man.	Comments
3.2.2	4603	(TG5)7	92		822W	7	18	WM	
3.2.2	+4787	(GD3)107c gr. 98	130		H820ER	12	100	WM	
3.2.3	2071	(AB5)32 (BF3)8	67		820ER	10	25	WM	
3.2.3	2784	(AD5)112 (BD2)24,26,28,50,100 (TG5)16	67 69 92 94	700E/SH	820ER 820ECR 820EW	9-13	100	WM	
3.2.3	2987	(AB4)23 (AD5)115,129	69 90 102		820ER 820EW		104	WM	
3.2.3	3029	(TG5)1 (ZH5)11,36,37	94 95 100			8-9	43	WM	
3.2.3	3105	(ZH5)36,37,38	95			8-9	17	WM	
3.2.3	3344	(AD5)154	94		820ER	12	33	WM	
3.2.3	3668	(TG5)65	-			9	25	WM	
3.2.3	3916	(FQ4)7	92	1156		8	22	WM	
3.2.3	4025	(CE4)98 (TG5)73	92 94		820EP RBR	9.5	80	WM	
3.2.3	4029	(FP6)92 (TG5)73,87	65 67 95	700E	820EP 820ER RBR	10	39	WM	
3.2.3	4086	(TG5)94	-			-	-	WM	
3.2.3	4511	(CE4)48,71	115 132	831EBR	820EO	8-12	29	WM	
3.2.4	+2882	(JE2)4 (HA1)1075 12	130 116	62g 831EBL	820ER 820EO	8-9.5	147	WM	
3.2.4	+2883	(HA1)1075 12	130	836EBR	820EO	9.5	100	WM	complete
3.2.4	+2884	(HA1)1075 12	130	833EBR	820EO	9.5	130	WM	1 complete
3.2.4	+4327	(JH3)39 (39)	106		820ER	8.3	100	WM	
3.2.5	3690	(JH3)8,94	106	831EBL	820ER	8.5	-	WM	
3.2.5	3694	(JH3)44,67	132	1289 1291 831EBL	820EO	8	100	WM	
3.2.5	+4326	(HA2)3 - (JH3)130 gr. 116	11 132	134g 1292 831EBL	820ER	8.5-11	115	WM	
3.2.5	+4328	(JH3)130 gr. 116	130	831EBL	820EO	8.5	100	WM	
3.2.5	+4329	(JH3)130 gr. 116	132	1289 1290 831EBL	820EO	8.5	100	WM	
3.2.6	+2881	(CF3)5 (JH3)6,44,57,67 70 1075 12	105F 106 130 132	1173	H820EO 820ER	9-10	90	WM	
3.2.6	3695	(JH3)44,67	34	1289 1291 831EBL	820ER	8.75	36	WM	white residue
3.2.6	+4330	(CE4)32,47,85 (CE5)1 (CF3)1,5,11,22,41 (CF4)1,18,20,30,128,132 (CF5)1 (JE2)9 (JE3)2 (JH3)130 gr. 116 (TG5)1	65 69 80 92F 94 100 106 115 130 132 132F 133	135g 150g	820EO 820ECR 820ER 820EBR	8-12	330	HM WM	
3.2.6	+4551	(JG1) gr. 12	-		820EO	7.5	100	HM	complete
3.2.7	3039	(ZH5)30	-		820ER	10	-	-	
3.2.7	3579	(JE3)120 gr. 115	112?	855E		10	-	WM	
3.2.7	3684	(TG5)29	136			10	18	WM	import
3.2.7	3982	(FQ3)3,43 (JD2)51 gr. 40	45 130 132		820EO\BR 820ECR 820EW\BR 825IBL	8-12	34	WM	(FQ3)43 from brick
3.2.7	4394	(CE4)37 (CE5)5 (CF4)20,57,65,128 (CF5)4 (TG5)1,4	67 92 94 94L 115 130	165g 831ER	820ECR 820EP 820IW H820EO H820ER 825ECR	6-11	126	WM	
3.2.7	4459	(CE4)14,85 (CF3)22 (CF4)59,65,109,128, 133,155 (TG5)4	92 94 115 122 130 132	163g 831EBR 850	820EO 820ER 820ECR 825EO	8-11	115	WM	
3.2.7	4493	(CE4)11 (CF3)49 (TG5)1	16 94 113	832EBR	820ER H820EBR	4-9	31	WM	
3.2.7	+4803	(GD3)147b gr. 20	132	838EBR	820EO	9	100	WM	

Fig. no.	Type	Provenance	Fabric	Dec.	Surface treatment	Dia.	%	Man.	Comments
3.2.7	+4804	(GD3)147c gr. 20	94L	1276 837EBR	820ER	9	100	WM	
3.2.7	4828	(JE2)12 -	94		825ER/P	6	-	WM	
3.2.8	+3538	(HA2)67 gr. 67 (JD2)4 -	100 116		820EP 820ER	8.3	100	WM	
3.2.8	3543	(JE3)1,10 -	100		820ER	9	25	WM	
3.2.8	3562	(JE3)24,25,26 gr. 115 (TG5)18,29	105 106		820ER 822W	7.5-10	56	WM	
3.2.8	3616	(HA2)74,203,229,250 gr. 67/229 136 - 208 gr. 207 (JF2)58 gr.55	100 106		820ER	-	-	WM	
3.2.8	3924	(FQ4)63	100	831ER	820EW	10	40	WM	
3.2.8	4269	(FO7)20B (FZ1)24 (FZ2)1	102 103 113 128		825EW ribbed	16-19	200	WM	(FO7) oil stain
3.2.9	3661	(TG5)18	-			39	-	WM	<i>krater</i>
3.2.9	3665	(TG5)18	92			17	5	WM	
3.2.9	3948	(FQ3)40 (TG5)1,44	67 94		825EW	28-34	11	WM	(FQ3) from brick
3.2.9	4379	(CF3)1,13 (CF4)101,128 (FO6)1 (TG5)1,7	88 92 94 106		820ER 820EO 822BR 822P	22-35	35	HM WM	
3.2.9	4451	(CE4)23 (CF3)49	69 94L		820ER	19x17 38x18		WM	
3.2.9	+4786	(GD3)70C gr. 45	116		820ER	8	100	WM	
3.2.9	+4810	(CE4)2	80	1286 839EBL	820EY	29	20	WM	
3.2.10	2554	(AB4)1	92			7	14	HM	
3.2.10	2781	(BD3)16	94			5	20	HM	
3.2.10	2874	(AB5)212 (AC5)77 (JG1)20	71 94 105			5-11	59	HM WM	
3.2.10	3157	(HA2)52 -,68 gr/ 204, 80 gr. 79	13		825EBL	5	20	WM	
3.2.10	+3558	(JE3)1,2,28	112	855E		8	21	WM	
3.2.10	4253	(FO6)61 (TG5)112	92 94			8-15	17	HM WM	
3.2.10	+4333	(JH3)39	139	1293	820ER	7.8	100	WM	
3.2.10	4486	(CF4)62,67,96	69/92	832EBL 832EBR 832ER	820ECR	14	17	WM	999
3.2.10	+4564	(CF3)41 (CF4)145	94	834EBR 831ER	820EY	8	26	WM	
3.2.10	4565	(CF3)41	94		822R	9	19	WM	
3.2.10	+4653	(JF2)10 gr. 2	112?	855E	820ER	10	100	WM	
3.2.10	+4802	(GD3)70B gr. 45	105		820EO	6	100	WM	
3.2.11	424	KS8999	57F		825EW	5	100	WM	
3.2.11	2080	(BD3)22 (BF2)31	67 94			15	21	WM	
3.2.11	2158	(BE2)73 (BF3)9	71 92			13-22	17	WM	
3.2.11	2163	(BF3)9	23			2	100	WM	
3.2.11	2179	(BE3)57	49			2.5	100	WM	
3.2.11	2202	(BF3)50	80			11	10	WM	
3.2.11	2253	(AB4)1 (AB6)8 (BE2)66 (BE3)78 (BF1)56 (FR3)2 (FS3)2 (FZ1)24 (TG5)91	11 24 67 80 92			7-21	85	HM WM	
3.2.11	2483	(BE3)16	32		820EO	2	100	WM	
3.2.11	2491	(AB5)1 (BE1)85	69 94			-	2	HM WM	
3.2.11	+2531	(BD2)32,80 (BE2)50 (JD2)1	25 69 80 94		825EW	9.5	103	WM	
3.2.11	2621	(BE2)71 B12 -	26 33		820EW	2-4	120	WM	
3.2.11	2755	(BF1)61	93		825EW	5.5	50	WM	

Fig. no.	Type	Provenance	Fabric	Dec.	Surface treatment	Dia.	%	Man.	Comments
3.2.11	2801	(BD2)71	67			7	19	WM	
3.2.11	+2847	(BD2)99	65L			26	100	WM	
3.2.11	2854	(BD2)71	67			5	50	WM	
3.2.11	2867	(AB5)92	92			13	13	WM	
3.2.11	2904	(BD2)28	67			7	40	WM	
3.2.11	2905	(BD2)29	69		V820ER	6	100	WM	Vertical wear marks
3.2.11	2906	(BD2)94 (TG5)117	92 98		820ER	5-9	36	WM	
3.2.11	2978	(AB4)23 (TG5)109	67 93		825EP	4-7	118	WM	H scar
3.2.11	2999	(ZH5)13	-			8	-	WM	
3.2.11	3018	(AC5)17	65		825EW	7	15	WM	
3.2.11	3080	(AD5)1	92			14	9	WM	
3.2.11	3091	(AD5)4	13			7	10	WM	
3.2.11	3168	(FT3)2	79			4	50	WM	
3.2.11	3356	(AD5)167	95		825EBR	9	25	WM	
3.2.11	3402	(AD5)168	108		820EBR	9	16	WM	
3.2.11	3407	(AD5)99	104		820ER	-	-	WM	dented
3.2.11	3435	(FO6)13 (FS3)11	65 92F			6-10	20	WM	
3.2.11	3586	(TG5)70	92S			2	100	WM	
3.2.11	+3693	(JH3)53,58 gr. 43	53B		820ER	2.5	200	WM	1 rim, 1 complete
3.2.11	3710	(AD5)227 (HA2)197 gr. 79	65 105			14-15	20	WM	
3.2.11	3952	(AD5)-	108		820EP	9	15	WM	
3.2.11	4088	(TG5)94	-			12.5	-	WM	
3.2.11	4097	(TG5)95,100	114			4	-	WM	
3.2.11	4098	(BE4)15 (TG5)95	69 114			5-6	45	WM	(TG5) 898 4097x 999
3.2.11	4156	(FO6)66,107,114	102		ribbed	25	-	WM	
3.2.11	4166	(FO6)138	113		825EBL	3	100	WM	
3.2.11	4209	(TG5)96	-			5	-	WM	
3.2.11	4214	(TG5)102	-			7	-	WM	
3.2.11	4220	(TG5)105	-			5	-	WM	
3.2.11	4281	(CF4)28 (TG5)113	80 92F			11-12	28	WM	
3.2.11	4434	(TG5)1	65		820ECR	8	35	WM	
3.2.11	4501	(CF4)138	69		820EW	8	15	WM	
3.2.11	4505	(CF4)128	94C		830ECR 831EBR 830IR	11	14	WM	
3.2.11	4568	(CF4)161	103		820EW	8	30	WM	
3.2.11	4571	(CF4)112	67			14	13	WM	
3.2.11	4610	(TG5)102-105	67		820IR	5	25	WM	
3.2.11	4616	(TG5)4	94		825EIR	6	12	WM	
3.2.11	4619	(TG5)12	132		820ER	0.6	100	WM	
3.2.11	4620	(TG5)12	92		820EW	8	23	WM	
3.2.11	4622	(TG5)12	106		820ER	3	20	HM	
3.2.11	+4784	(GD3)79b gr. 11	104		820EBR/R	2	100	WM	
3.2.11	4819	(FZ2)31	102		825EW	10	18	WM	
3.2.12	2064	(BE3)1,63 (BE4)9,19,37 (BF1)45 (BF2)38 (CE4)1 (CF3)11	2 67 94	850 x 2	822W RBR	13-28	96	HM WM	
3.2.12	2093	(BD2)71 (BF3)38,50 (JD2)18 (JG2)1	9 80 92 94C		820ER 822R	10-19	57	HM WM	
3.2.12	2121	(BE2)1 (BF3)1,50,58	67 69 80		820EW 832W	8-20	37	WM	
3.2.12	2141	(BE2)31 (BE4)14	61 67		825ER	9-20	22	HM WM	
3.2.12	2172	(AB4)10 (BE1)85 (BE2)73,158 (BE3)69 (BF1)72	25 67 69 76 80		825EW	11-22	90	HM WM	

Fig. no.	Type	Provenance	Fabric	Dec.	Surface treatment	Dia.	%	Man.	Comments
3.2.12	2404	(AB4)11,33 (AC6)12 (BD2)28,101 (BE4)60 (BF2)56	67 69 80 94		820EW	19-38	49	HM WM	
3.2.12	2424	(BE4)19 (TG5)5/4	25 92			8-10	26	WM	
3.2.12	2436	(BE3)27 (FQ3)42	2 79			23	6	WM	(FQ3) from brick
3.2.12	2534	(BD2)71 (BE2)51 (BE3)146	67 93 94F		825IW	10-17	39	WM	
3.2.12	2556	(BE2)83 (TG5)74, 102-105	80 94			10-13	34	WM	
3.2.12	2609	(AB5)80 (AC5)49 (ZH5)60	90 92		820EW	22-24	75	WM	
3.2.12	2614	(AB5)89	92		820EO	13	10	WM	
3.2.12	2747	(BF1)31 (TG5)22	24			11	22	WM	
3.2.12	2815	(AB4)24	92			11	20	WM	
3.2.12	2817	(AB6)25	38		822P	9	9	WM	
3.2.12	2918	(AB4)20,23	92 93		825EW	8-11	20	WM	
3.2.12	2922	(AB4)22 (AD5)112	92			9-18	21	WM	
3.2.12	3033	(ZH5)17	-			14	-	WM	
3.2.12	3175	(FQ3)40 (FR3)1	80 98			12-13	18	WM	
3.2.12	3188	(AC5)68 (AD5)0 (BF3)9 (CE4)9 (CF3)49 (TG5)1	69 92 94		822CR 822W	6-13	64	HM WM	
3.2.12	3279	(TG5)117	OF		ribbed	8.5	16	WM	
3.2.12	3295	(AC5)57 (FQ3)7	80 118		820ER	10	24	WM	(FQ3) from brick
3.2.12	3350	(AD5)160,161 (CE4)85	94			13	38	WM	
3.2.12	3585	(JE3)1	-			7	-	WM	
3.2.12	3590	(TG5)22	-			10	-	WM	
3.2.12	3664	(BE4)20 (TG5)18	67 80	850 x 1		12	12	WM	
3.2.12	3685	(TG5)29	-			12	-	WM	
3.2.12	3818	(AC5)112 (AD5)276	23		825EW		40	WM	
3.2.12	3926	(FQ3)40	94			24	6	WM	from brick?
3.2.12	3931	(FR4)2	92			14	30	WM	
3.2.12	3983	(CF3)1 (FQ3)43 (TG5)5/4	67 92 94		810E 820EY	18-25	26	WM	
3.2.12	4039	(TG5)87	92			17-23	22	WM	
3.2.12	4203	(TG5)95	-			12	-	WM	
3.2.12	4224	(TG5)95	-			14.5	-	WM	
3.2.12	4279	(TG5)77	92F			10	7	WM	micaceous
3.2.12	4288	(TG5)114	94			11	15	WM	
3.2.12	4357	(CE4)85 (CF4)1,50	69 80 94		820EO	14-22	20	WM	
3.2.12	4392	(CF4)20 (TG5)5/4,12	67 94 110			10-14	52	HM WM	
3.2.12	4405	(CF4)18	69		820EP	9	85	WM	
3.2.12	4483	(CF4)113	67			13	16	HM/ SW	
3.2.12	4544	(CF4)69	92			10	17	WM	
3.2.12	4585	(CF4)102	92		822W	13	9	WM	
3.2.12	4601	(TG5)7	67		825IR	22	11	SW	
3.2.12	4645	(BF3)8 (FP6)89	67 94		822P 825EW	10-19	14	WM	
3.2.12	4702	(BE4)14 (FP6)109	94 102		820EW 825IP	-	5	WM	
3.2.12	4814	(AD5)1	-			15	17	WM	

3.3. Jars, both handmade and wheel-made, pigeon pots

Restricted and open-mouthed jars, arranged according to the similarities of the rims.

3.3.1 Restricted and open-mouthed jars, with single or double beading

Note the similar rims, but with a more vertical neck, in 3.1.10.

2138x: Nu.72 (9, 623-593 BC) fig. 49, 18-1-128 red ware.

3103x and **4387x:** Ku.101 (45-55? 43 BC-AD 115) fig. 36a, 19-3-931, black ware.

3133x: Note similarity of form with 4553x, a Kerma form (6.1)

4010x: Beg.N.11 (36, 186-177 BC) fig. 44, 21-3-374 red ware, with graffito on neck (Dunham 1965, 138 group IV.3).

3.3.2 Wheel-made closed jars with triangular / bevelled rim, ovoid body, and variants thereof

2218x: Nu.12 (21, 418-398 BC) fig. 163, 17-3-340.

2332x: Nu.1 (5, 690-664 BC) fig. 3, 17-2-1916, with wider diameter; also fig. 4, 16-12-211.

+4552x: Barkal pottery type XII;² Bar.1 (45, 43-26 BC) fig. 133, 16-2-287; Bar.8 (32.I, 263-248 BC), fig. 32, 16-2-379, red ware.



Plate 3.3.1. Jar 4552x.

3.3.3 Handmade jars with short necks and beading variations

4382x: Nu.11 (19, 453-423 BC) fig. 149, 17-1-21; NU61 (23, 397-362 BC) fig. 180 18-2-357 red ware.

4767x: Nu.49 (18, 458-453 BC) fig. 146, 18-1-119.

4794x: Laming Macadam 1955 II, pl. XXXIII.3 [2100], Meroitic.

3.3.4 Plain beaded open-mouthed and restricted jars of varying sizes

2168x: Nu.4 (17, 478-458 BC) fig. 135, 17-2-1902, hole in same place though angle different. Also note similarity with 2000x variant (3.3.6).

3.3.5 Handmade jars with plain rims and no or short neck

2488x: Ku.19 (B, 840-820 BC) fig. 24C, 19-3-846.

2916x: Ku.19 (B, 840-820 BC) fig. 24C, 19-3-864; and infra, 2851x (1.10); Aston 1999, pl. 65 1902.

2979x: Nu.49 (18, 458-453 BC) fig. 146, 18-1-119, but wheel-made.

3938x: Mohamed Ahmed 1992, 1A19a-b (late 7th to mid 6th centuries BC) and IIIA1a.

3.3.6 Handmade jars with short neck

2000x variant: Ku.62 (3, 716-701 BC) fig. 33b, 19-3-1491. Note also its resemblance to a nearly complete vessel from Dokki Gel on display in the Kerma Museum (a different example is illustrated in Ruffieux 2007, pl. 6.63).

2167x: The oblique finger marks have a close parallel in Mohamed Ahmed 1992, 1A19a, late 7th to mid 6th centuries BC; Nu.56 (26, 328-308 BC) fig. 195, 18-2-337, red ware. Note a number of similar forms with apparently random oblique grooves or scratches below the shoulder, such as 3108x (3.3.6), 3501x (3.3.7), 3938x (3.3.5), 4767x (3.3.3). In other instances, e.g. 4789x (3.3.3) the obliqueness is more likely the result of the manufacturing process, rather than intentional marks.

3855x: The handle(s) make this form reminiscent of the Napatan amphorae (cf. e.g. 4799x, 3.1.4). There exist examples of handmade 'copies' of the wheel-made containers (Nu.13 (23, 397-362 BC), fig. 172, 17-4-866, pl. CXXXV.H; Heidorn 2018, 330; see also MFA acc. no. 24.4008, from Nuri, but not the same vessel as illustrated by Dunham).

3.3.7 Crude handmade storage jars

Some with externally roughly thickened body. For a general parallel see Heidorn 1994, 122, fig. 3.e, dated to the Third Intermediate Period and to the 25th-26th Dynasties.

4482x: Mohamed Ahmed 1992, fig. 24 II A7 (early 7th to mid 5th centuries BC).

3.3.8 'S'-shaped jar rims, hand and wheel-made

3539x: Phillips 2004, fig. 1D Magal 6, with 'barley seed' impressed decoration (1136y), Islamic period. Although this is a very convincing parallel, note that the same form also occurs in wheel-made Meroitic fineware from Temple B560 at Jebel Barkal (Baginska 2018, 491, fig. 2.d-e). 3539x was found on the surface and is very abraded, with no surviving surface finish, but the vessel is undoubtedly handmade.

3.3.9 Open-mouthed beaded jar rims; open-mouthed jars with angular, square rims, similar to *krater* rims

Restricted vessels with no direct parallels. The beading at the rim would allow for sealing the jar with a cloth, as well as strengthening the rim.

3.3.10 Open-mouthed jars, mainly wheel-made; open and restricted jars (cooking pots?) with lid seating

This latter group, presented at the bottom of the figure, has alternatively been dated by Williams to the first two centuries AD (1991, 67-69, fig. 37), and given the contexts in which the examples at Kawa have been found, this might be more plausible. Whether or not they are imports from Egypt or not is another matter, as they are all made of Nile silt fabrics with a white slip or wash, and not pink as the examples at Qustul.

4464x: With wider diameter, Jacquet-Gordon no date, fig. 10.9, pre-30th Dynasty.

4465x: Ku.53 (2, 751-716 BC) fig. 29b, 19-3-1362, polished red ware. Not an exact parallel, but with similar lid seating. Another possible parallel dates to the 5th-early 4th centuries BC (Jacquet-Gordon no date, fig. 10.8).

4496x: Jacquet-Gordon no date, fig. 18.3, pre-30th Dynasty (mid 4th century BC).

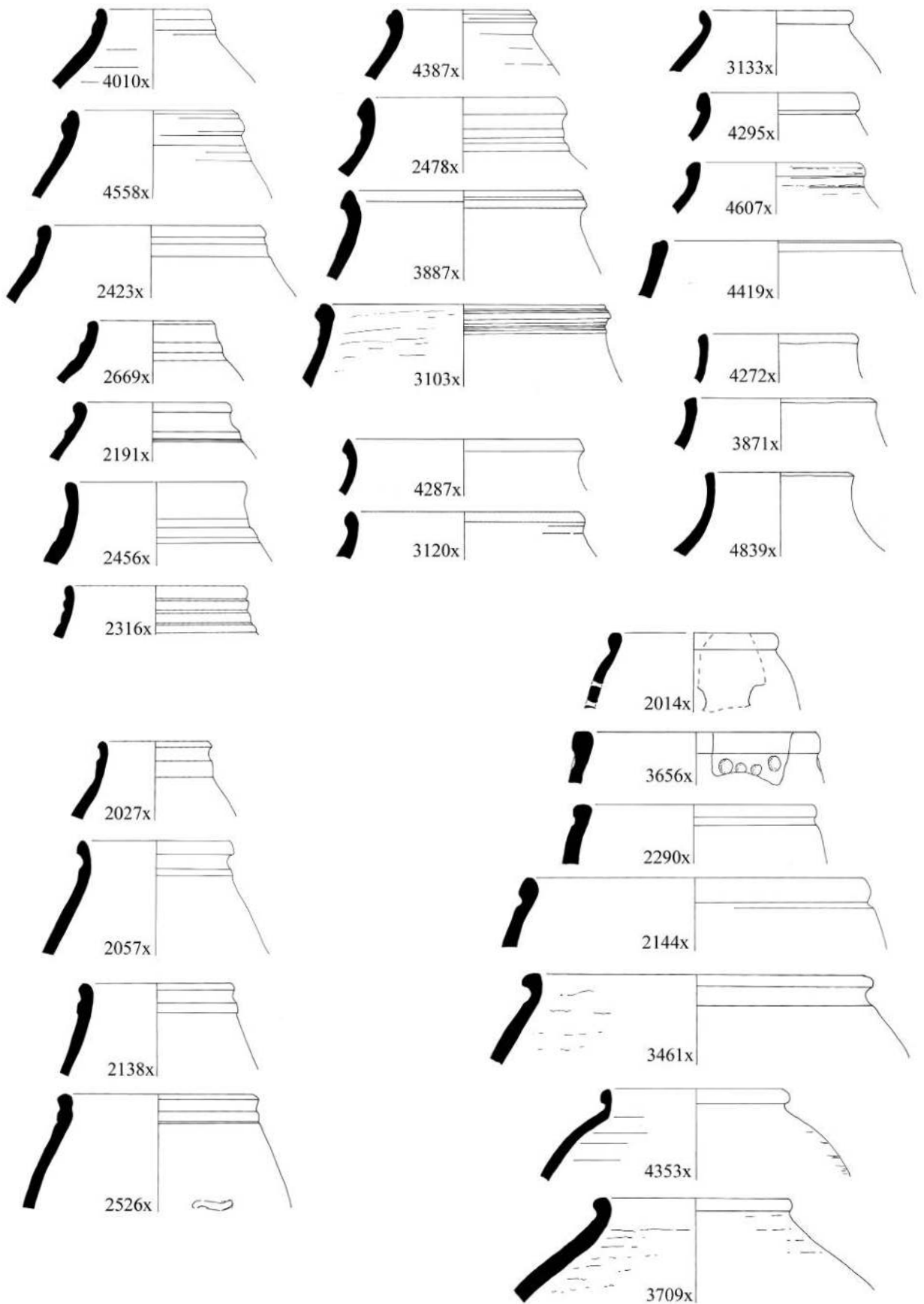

Figure 3.3.1. Restricted and open-mouthed jars (scale 1:4).

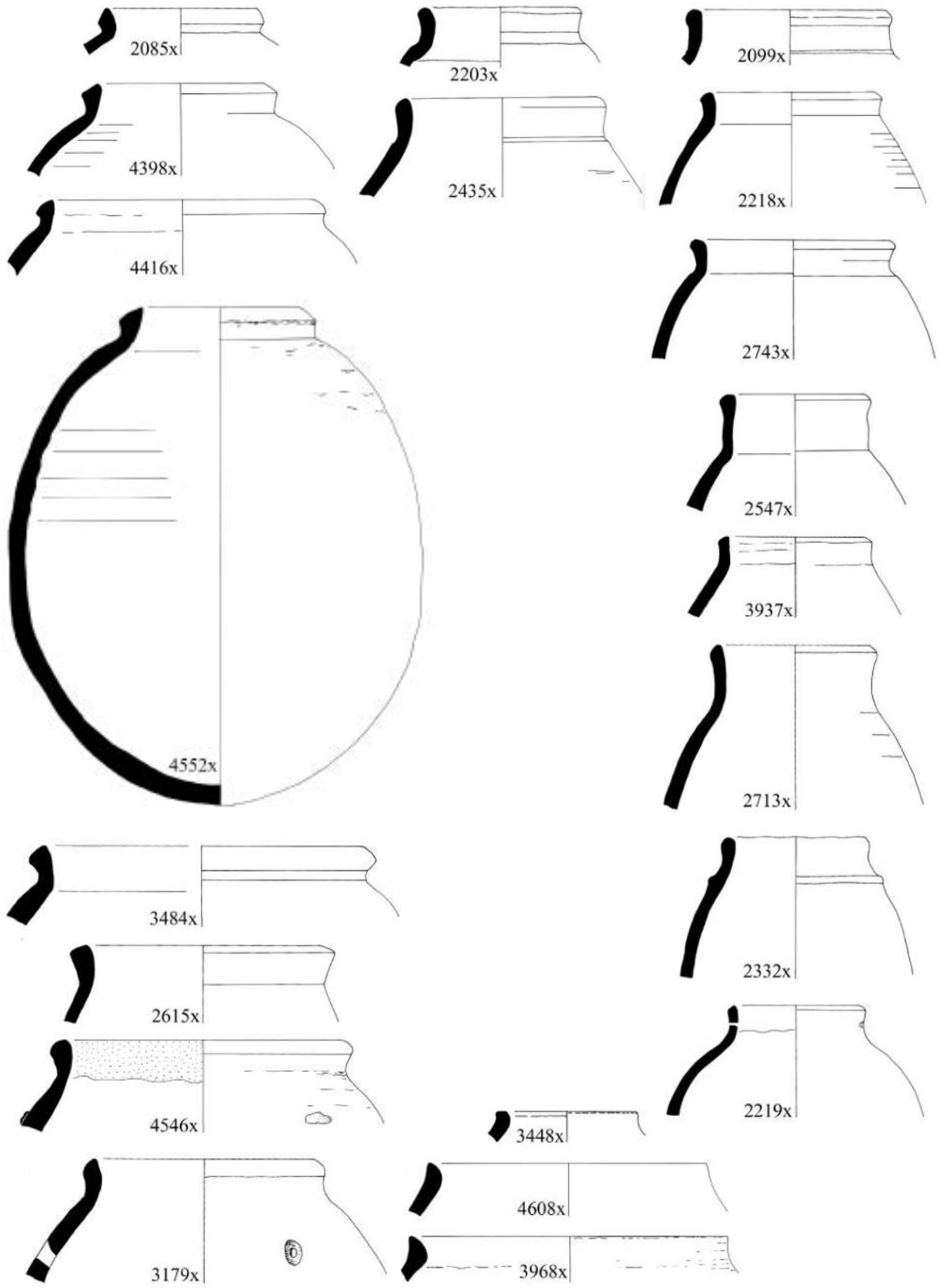

Figure 3.3.2. Wheel-made closed jars with triangular / bevelled rim (scale 1:4).

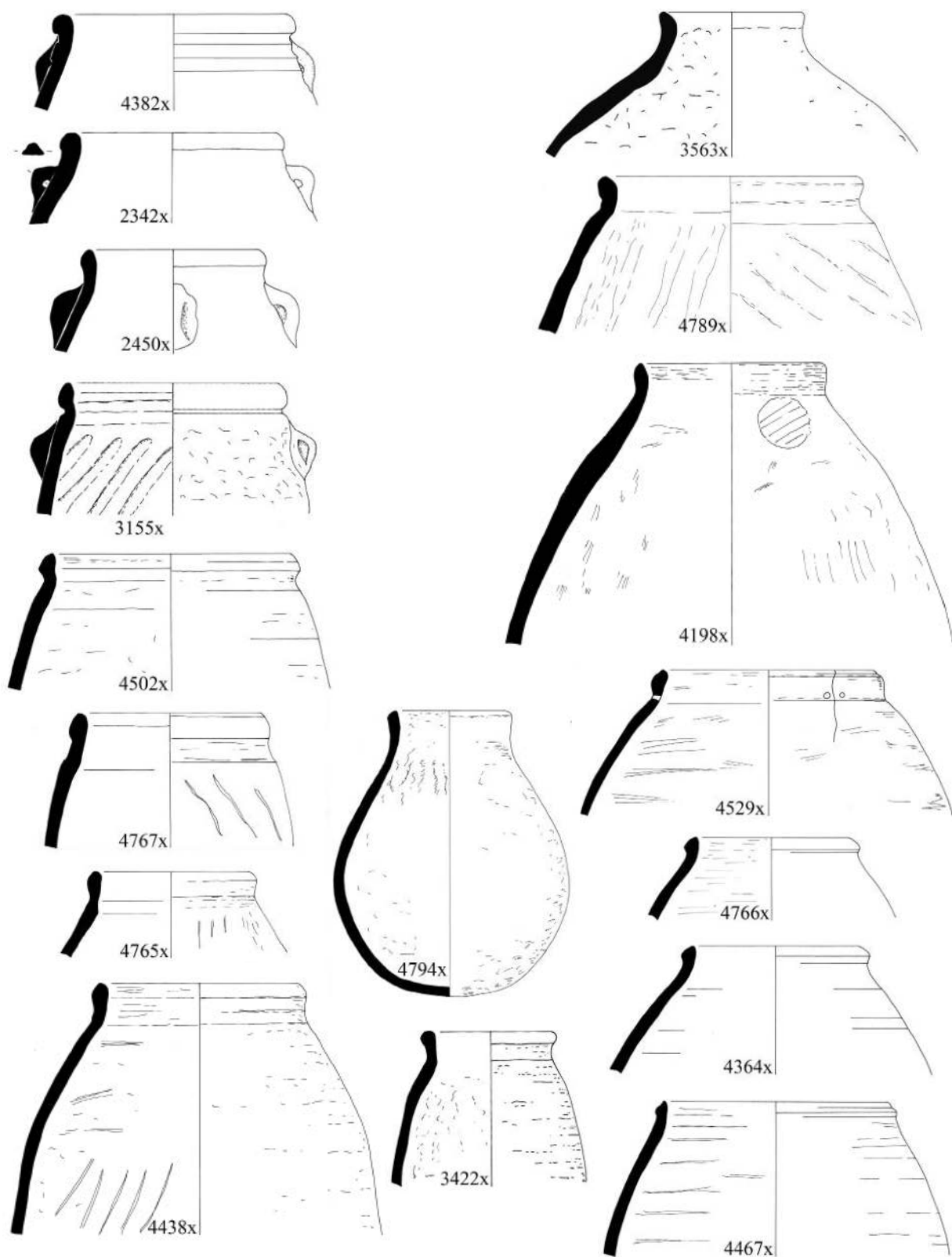

Figure 3.3.3. Handmade closed jars with short necks and beading variations (scale 1:4).

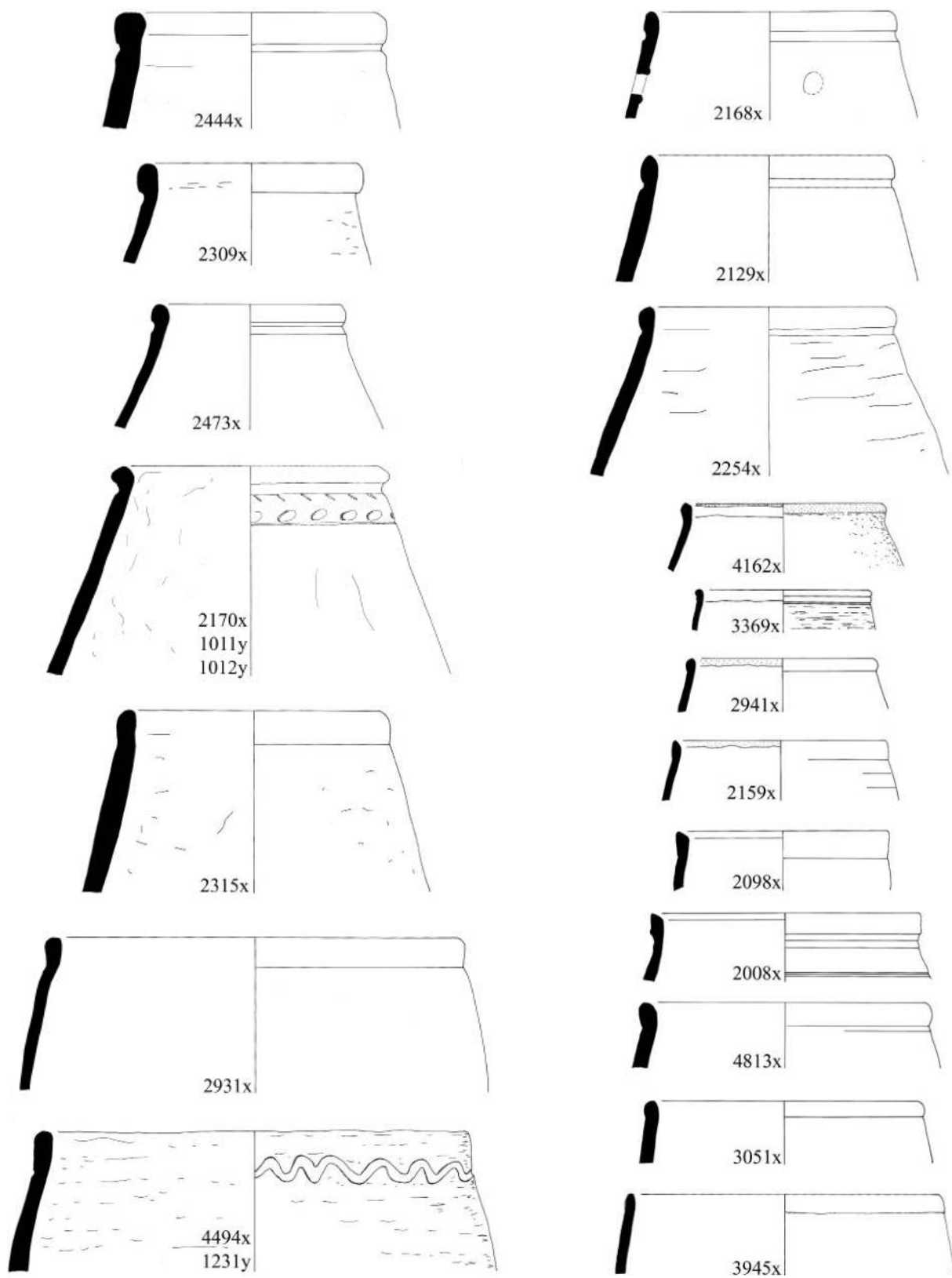

Figure 3.3.4. Plain beaded open-mouthed and restricted jars of varying sizes (scale 1:4).

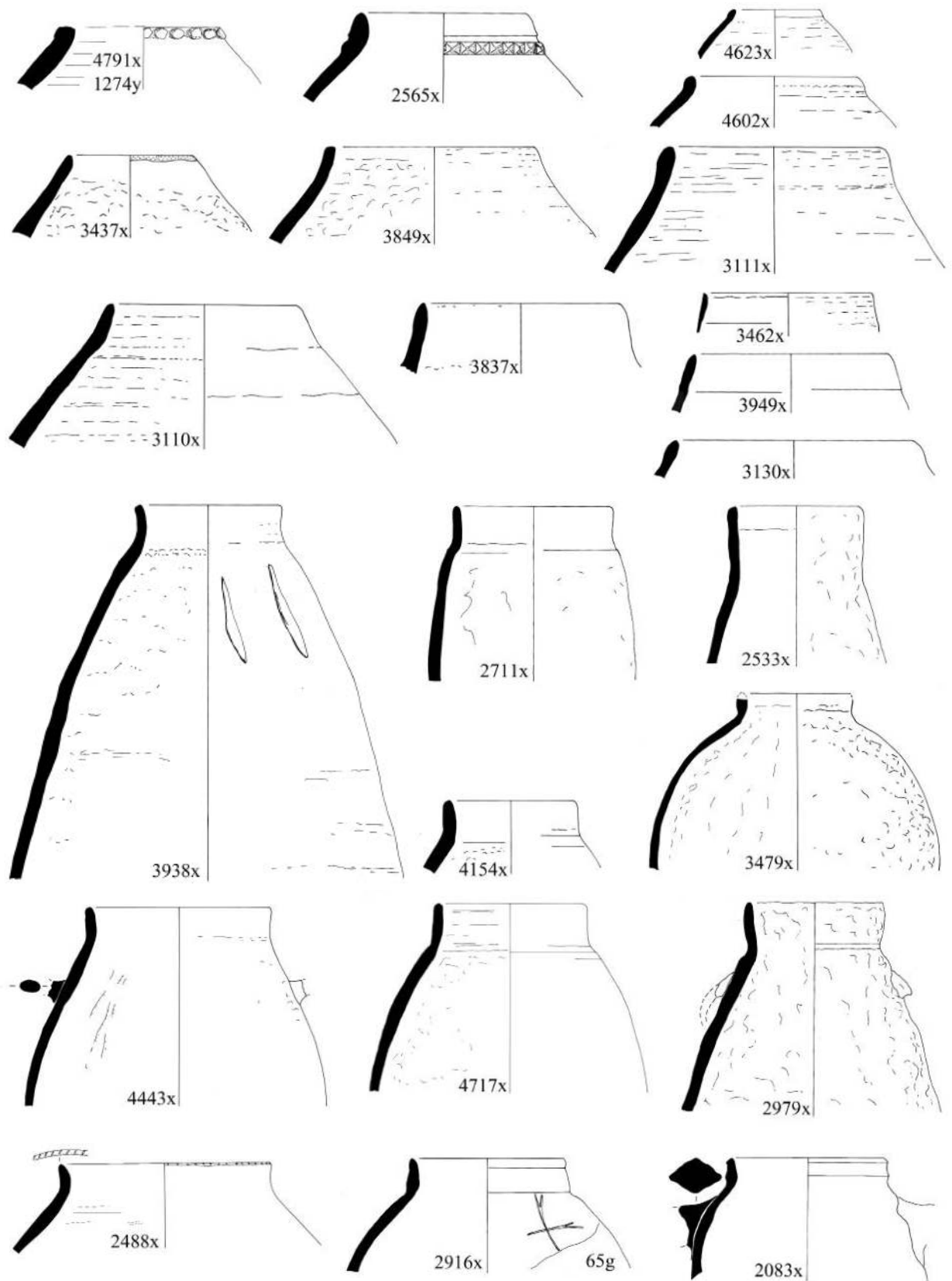

Figure 3.3.5. Handmade jars with plain rims, neck absent or short and vertical (scale 1:4).

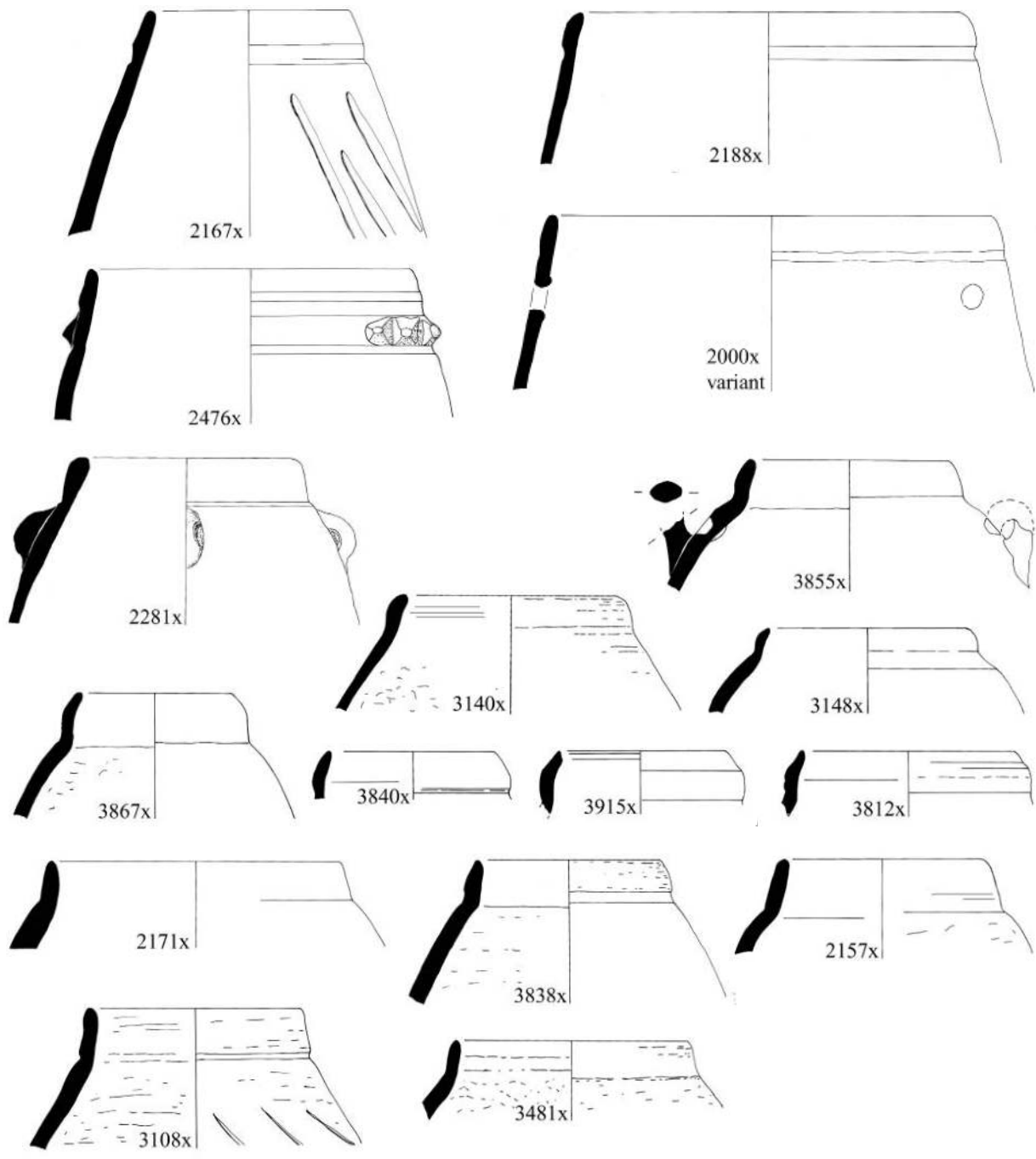

Figure 3.3.6. Handmade jars with short neck (scale 1:4).

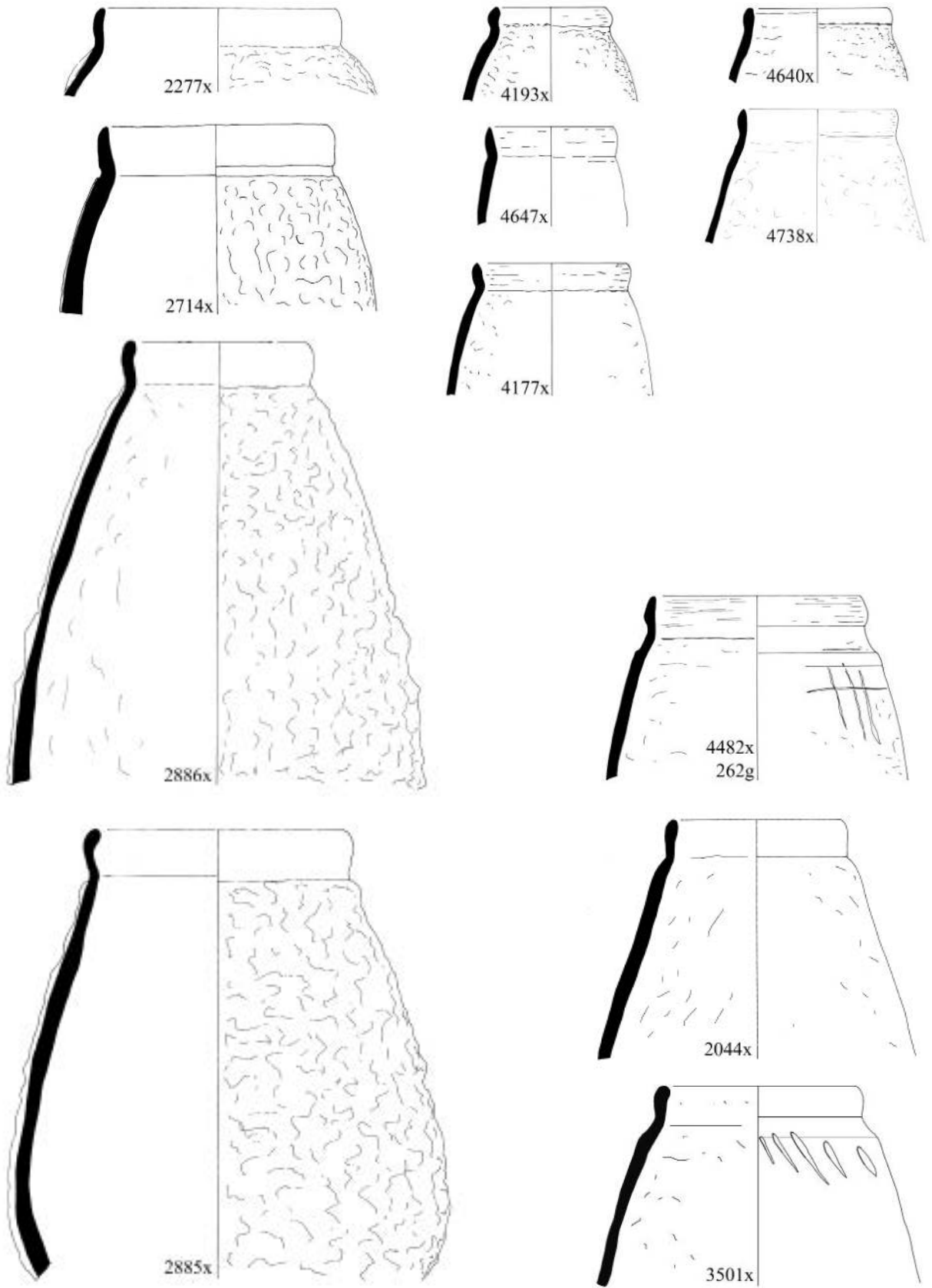

Figure 3.3.7. Crude handmade storage jars, some with externally roughly thickened body (scale 1:4).

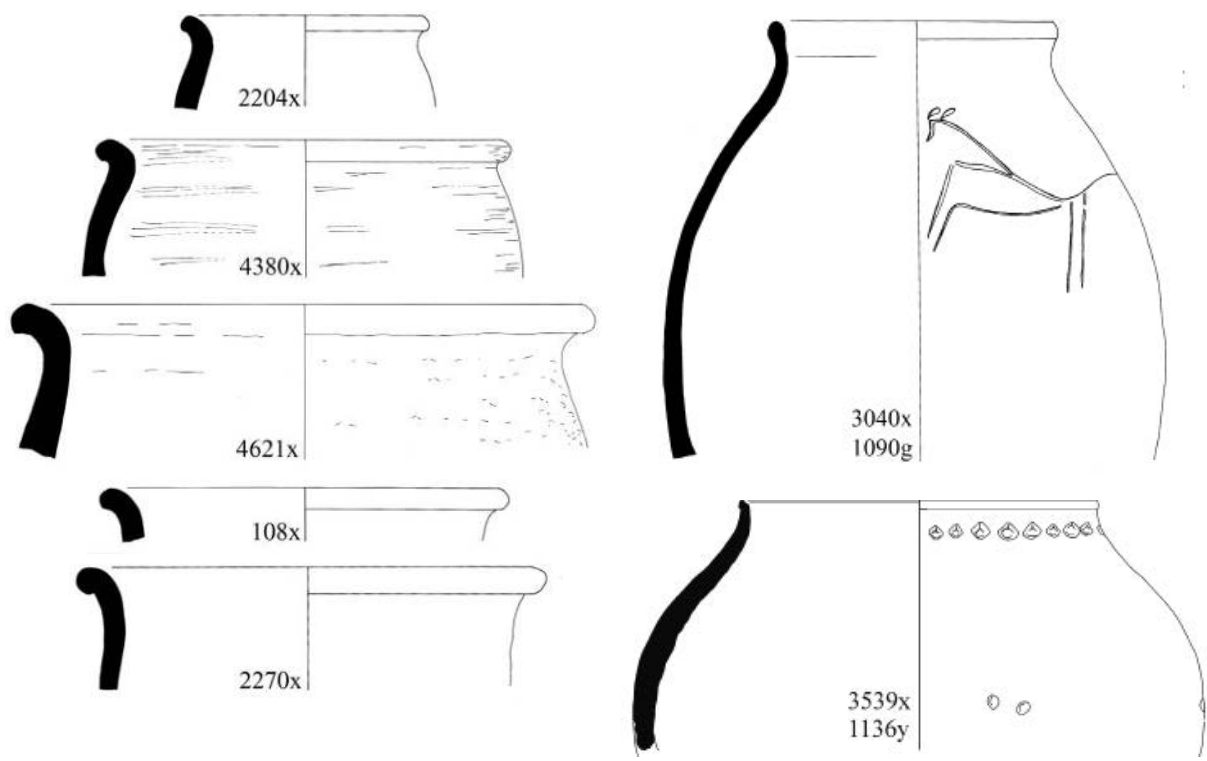

Figure 3.3.8. 'S'-shaped jar rims, handmade and wheel-made (scale 1:4).

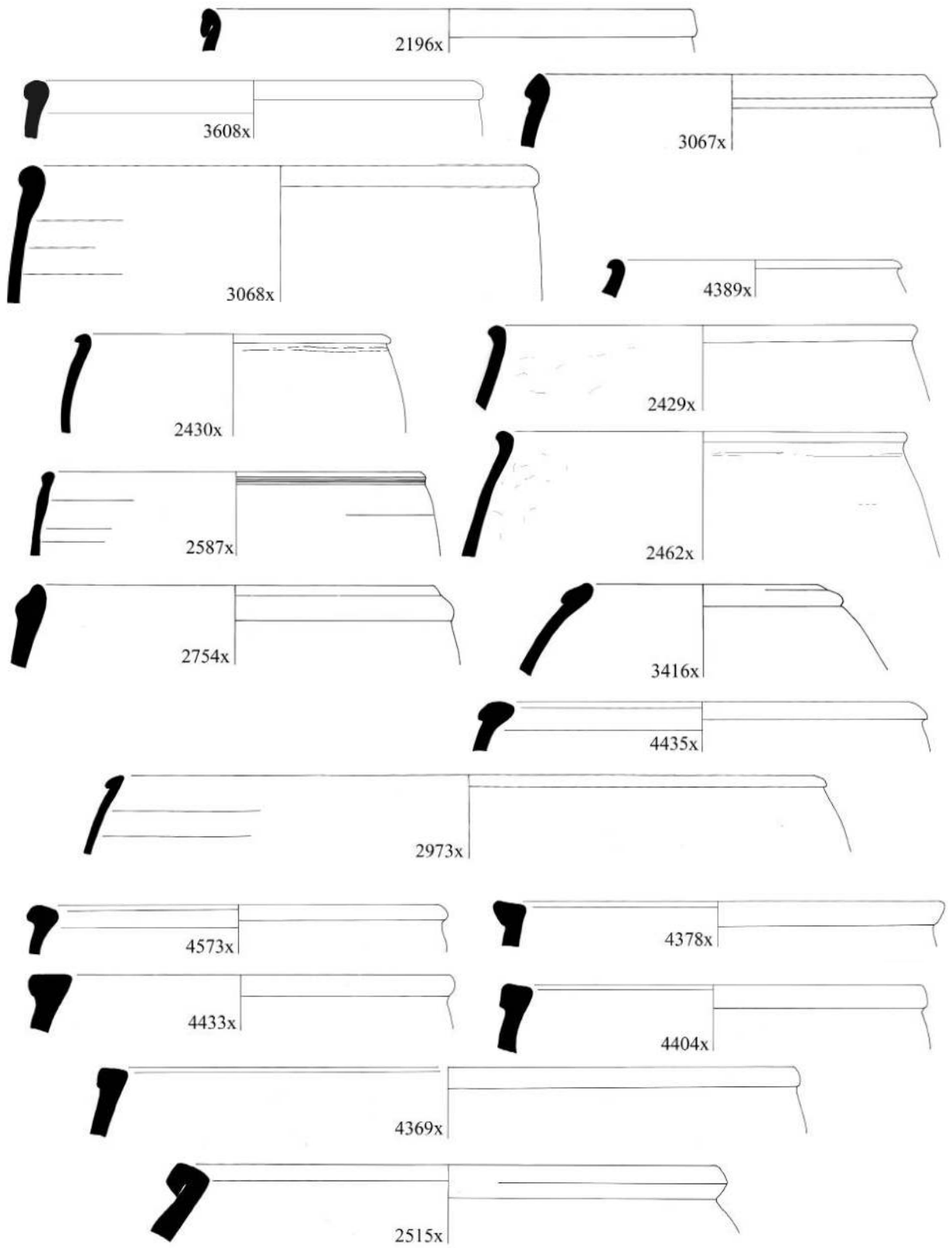

Figure 3.3.9. Open-mouthed jars with beaded rims; open-mouthed jars with angular, square rims (scale 1:4).

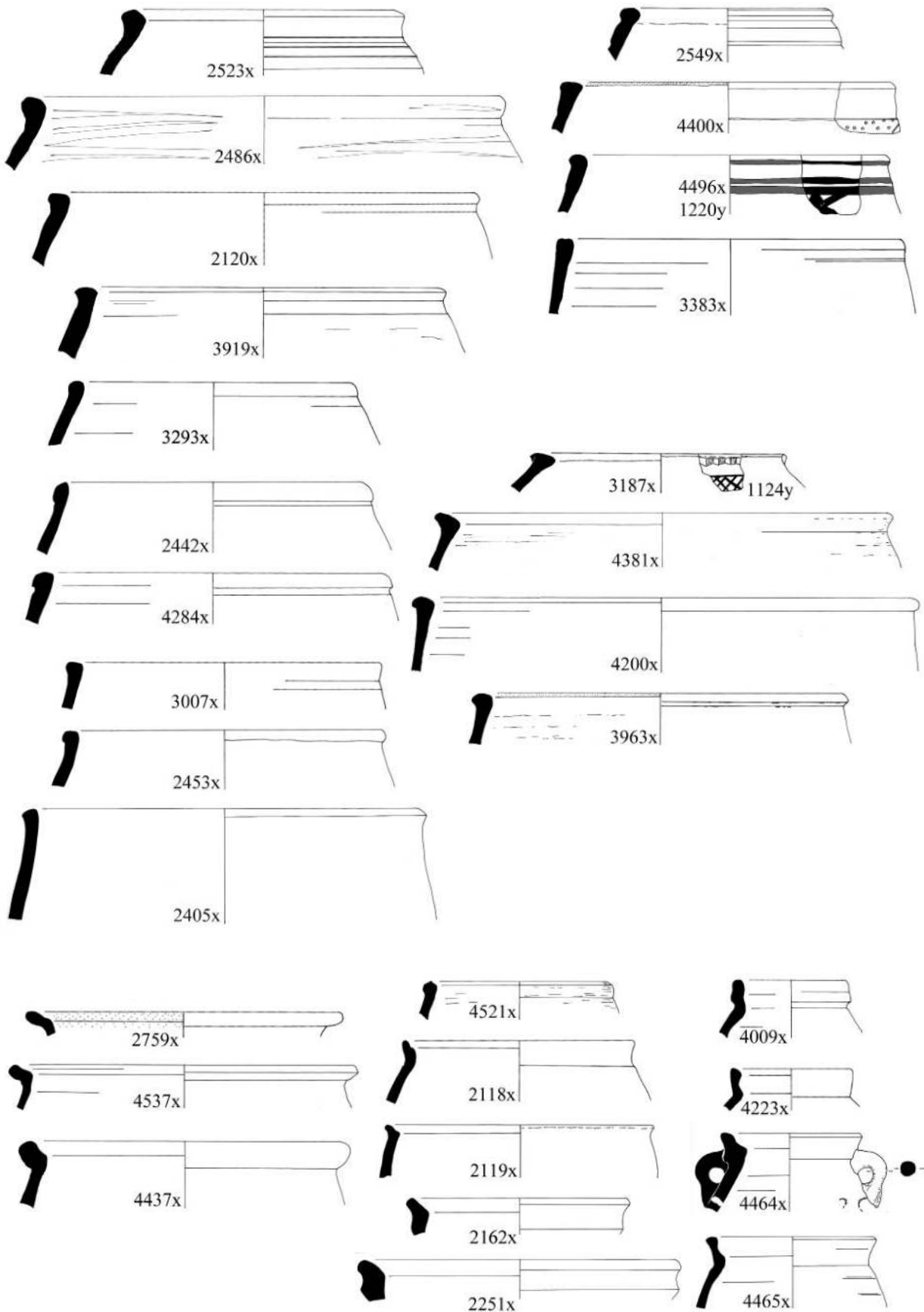

Figure 3.3.10. Open-mouthed jars, mainly wheel-made. Open and closed jars with lid seating (scale 1:4).

TABLE 3.3. JARS, BOTH HANDMADE AND WHEEL-MADE, PIGEON POTS.

Fig. no.	Type	Provenance	Fabric	Dec.	Surface treatment	Dia.	%	Man.	Comments
3.3.1	2014	(BE2)43 (BE3)56 (BF2)1 (CF4)56	9 69 80 94	851 (?) x 2		15-21	21	HM	
3.3.1	2027	(AB4)1,11,14 BC3 2 (BD2)28,47 (BE1)18,49 (BE3)78 (BF1)61 (BF2)1,32 (BF3)9 (TG5)85	25 65 67 69 80 93 94 94F	850 x 2	820ECR 820EW 825EIP 825EW BR- BRE	8-12	291	WM	
3.3.1	2057	(BD2)28 (BE2)104 (BE3)10 (BF2)15,38 (BF3)9 (TG5)96	9 66 67 69 80 92 94		820EP 820EW 825ER 825EW	8-11	90	WM	
3.3.1	2138	(BE1)51 (BE2)25	25 76			11	22	WM	
3.3.1	2144	(BD3)33 (BE1)7 (BE2)45 (BE3)27,55,63 (BF1)4,16 (BF3)15	67 69 70 75 80	1012 850	832W	11-25	95	HM WM	1 waster
3.3.1	2191	(BC4)1 (BD2)50 (BD3)28 (BE1)1,63 (BE2)67,73 (BF1)0,53,57,61 (BF3)8	65 67 69 80 94		820EW 825EW	8-13	160	WM	1 waster? rim notches
3.3.1	2290	(BE3)56	67	dribble E/P		18	13	-	
3.3.1	2316	(AC5)13 BC3 3 (BF3)38	25 69 92		822P	13-22	37	WM	
3.3.1	2423	(BD2)26,50 (BE4)19	2 50 92		825EI	9-16	46	WM	1 distorted
3.3.1	2456	(BC4)1 (BD2)27 (BE1)41 (BE3)10 (BF1)6	67 80 94 97		820EW 825EW	9-14	96	WM	
3.3.1	2478	(AB5)58 (AD5)207 (BE3)16 (BF1)4	69 92		V820EIR 825EW	12-27	36	WM	
3.3.1	2526	(AB4)20 (AD5)134 (BE2)48 (CF4)88	65 94 94C			10-15	80	WM	
3.3.1	2669	(AB4)10 (FR4)2	65 92 93 94		820ECR 825EIR/R	9-11	103	WM	
3.3.1	3103	(ZH5)15,37,38	98			21	31	WM	
3.3.1	3120	(BF2)38 (CE4)4 (CE5)1 (CF3)1 (CF4)20,132 (CF5)1 (FQ3)40 (ZH5)37	25 66 67 69 92 94			11-20	80	HM WM SW	
3.3.1	3133	(ZH5)48,82	92			11-27	18	WM SW	
3.3.1	3461	(AC5)78 (FR3)22	-		825EIR RBR TOP	24-26	23	HM	
3.3.1	3656	(CF4)56 (TG5)18	67 93	1012		23-25	13	HM WM	
3.3.1	3709	(AD5)227,312 (CF5)1 (FZ1)10	94 110		825ER RBRE	6-20	28	HM WM	
3.3.1	3871	(AD5)309,315 (BE3)63 (CF3)1 (CF4)109 (FP6)92	69 105 110		825EICR	10-14	80	HM	
3.3.1	3887	(BF2)1 (FQ4)2,7	93 117			17-18	20	HM WM	
3.3.1	4010	(CF4)1 (TG5)91	94 98			8	11	WM	
3.3.1	4272	(BF3)8 (TG5)138	92 94			11-15	14	WM	
3.3.1	4287	(FO6)121 (TG5)115	117		820ER 825ER	12-17	11	HM	
3.3.1	4295	(TG5)65	94		825ER	11	16	WM	
3.3.1	4353	(CE4)1 (CF4)101	67 94			12-13	53	WM	
3.3.1	4387	(BF2)31 (CE4)58 (CF3)5,14,20,22 (CF4)13,26,101	67 69 92 94 110		825EW	5.5-16	169	HM WM SW	
3.3.1	4419	(CF3)24	110			17	5	HM	
3.3.1	4558	(CF4)141	110			17	11	HM	SW?
3.3.1	4607	(TG5)35	94			12	14	SW	

Fig. no.	Type	Provenance	Fabric	Dec.	Surface treatment	Dia.	%	Man.	Comments
3.3.1	4839	(BF3)53 (FP6)125	61 110			10-12	19	HM	
3.3.2	2085	(BF1)56 (BF2)47 (FQ4)2,5	25 92 93		800E	10-15	37	HM WM	
3.3.2	2099	(AB5)1 (BF3)56	49 69			14	15	WM	
3.3.2	2203	(BE4)9,13	1 67			12-20	35	HM/ SW	
3.3.2	2218	(BE3)63 (CF4)13 (FQ4)1 (FS3)13	61 65 80 110		825EI	10-15	67	HM WM	
3.3.2	2219	(AB6)8 (AC5)39 (AC6)31 (BE1)80 (BE3)63 (CF4)1 (JE2)2 (FR3)0	25 76 80 92 110	871?	820EP RBR	9-13	137	HM WM	pre-firing hole
3.3.2	2332	(BD2)65 (BE1)1 (BE2)110 (BF1)53	67 69 76		825EIR	8-10	56	WM	waster
3.3.2	2435	(BE3)27	25			14	27	WM	
3.3.2	2547	(BE2)103	48			11	10	WM	
3.3.2	2615	(AB5)86 (CF4)112	80 94			17-23	10	WM SW	
3.3.2	2713	533 29 (BE4)13 (BF2)31	10 22 83			11-22	22	HM WM	
3.3.2	2743	(BF1)27,57,72 (FR3)2	67 80 92 94	850 x 1	825ER RBRI	10-15	91	WM	
3.3.2	3179	(FR3)2	89	850	825EIGR	16	6	HM	
3.3.2	3448	(FS3)6	95		822R/BR	10	13	WM	
3.3.2	3484	(AD5)219	110		RBR TOP	23	9	HM	
3.3.2	3937	(CF4)1 (FQ4)59 (FR4)7	67 92 110	R dribble		10-15	39	HM WM	
3.3.2	3968	(FQ3)58	94			23	6	WM	appliqué/R??
3.3.2	4398	(CE4)23,48 (CF4)51,57	69 92 94F			12	62	HM WM	
3.3.2	4416	(CE4)85 (CF3)49 (CF4)13,56,113 (FZ2)22	69 92 94 110		825EBR 825EW	8-19	177	HM WM	
3.3.2	4546	(CE4)48	105	boss?		20	11	HM	
3.3.2	+4552	(JG1)32 gr. 12	94			11.3	100	WM	complete
3.3.2	4608	(TG5)35	94		822R	20	6	HM	
3.3.3	2342	(BE2)10 (BF1)73	1 67		820ER	15-18	25	HM	
3.3.3	2450	(BE3)18 (HA2)29 (TG5)29	69 92 94			12	14	HM WM	
3.3.3	3155	(HA2)52 -,68 gr. 204, 80 gr. 79	69		820EW	15	8	HM	
3.3.3	3422	(AD6)13 (FP6)128	110		910	9-15	35	HM	
3.3.3	3563	(JE3)24 P2	92 110			8	27	HM	Meroitic
3.3.3	4198	(TG5)1	94		825EW	13	31	HM	HS/ boss
3.3.3	4364	(CE4)4,52,86 (CF3)1,5,13 (CF4)17,62,67,101, 103,113 (TG5)4	67 69 92 92F 94 106 110 110F		825EW	9-15	201	HM WM SW	
3.3.3	4382	(CF4)17	110			16	12	HM	
3.3.3	4438	(JG2)1,178,242,265, 266 gr. 175	105			14	95	HM	rim partly filed down 999
3.3.3	4467	(CE4)15,48,71,85 (CF3)22,41,43 (CF4)107,128 (TG5)4,5/4	69 92 94 94L 110			10-16	98	HM SW	
3.3.3	4502	(CE4)47 (CF4)103,128,142	92C 94 110			12-17	55	HM SW	
3.3.3	4529	(CE4)86 (CF4)109	92 110	850 x 2		15	31	HM	
3.3.3	4765	(JD2)51 gr. 40	105	vertical scratches	910	11	26	HM	
3.3.3	4766	(JD2)51 gr. 40	105			11	12	HM	
3.3.3	4767	(JD2)51 gr. 40	105			13	31	HM	

Fig. no.	Type	Provenance	Fabric	Dec.	Surface treatment	Dia.	%	Man.	Comments
3.3.3	4789	(GD3)92 gr. 95	92			18	50	HM	
3.3.3	4794	(GD3)21 gr. 20; 25 gr. 63	110			8	37	HM	999
3.3.4	2008	(BF2)1	92			19	10	WM	
3.3.4	2098	(BE3)18 (BF3)56	67 69		820ER 832O/CR	15-22	17	WM	
3.3.4	2129	(BE1)1 (BE2)48,103 (BE3)16,17,50 (BE4)42 (BF1)53 (CE5)5 (CF4)59 (TG5)5/4	1 25 65 67 69 92 94 110	850 x 1	825EW	10-27	127	HM WM	
3.3.4	2159	(BE1)63 (BE3)16,106 (BF3)8,9 (CF4)95 (JC2)12 (JC3)6	65 69 80 92 94 106 110		822CR 820ER RBRIE	13-16	60	HM WM	
3.3.4	2168	(BD2)71 (BE2)100 (BE3)1 (BF3)8	25 67 67 92	851	RBRE	17-25	25	HM WM	
3.3.4	2170	(BF2)31	67	1011 1012		18	11	HM	
3.3.4	2254	(AD5)87 (BD3)14 (BD4)8 (BE2)48,147 (BE3)27,56,78,118, 136 (BF1)45 (CF4)31 (FR3)0 (TG5)1	1 8 65 67 69 80 89 92 94	850	825EIO	12-33	207	HM WM	
3.3.4	2309	(BE3)27,116 (BF1)4,6 28,45	8 67 92			15-16	118	HM WM SW	
3.3.4	2315	(BE3)10,18,33,55 (CF4)17	1 69 92 110			14-18	108	HM	
3.3.4	2444	(BE3)10	67			18	24	HM/ SW	
3.3.4	2473	(BD3)1,33 (BE3)16 (BF1)45,53	2 67 69		825EW	10-18	89	WM SW	
3.3.4	2931	(AB4)31 (CF4)1	80 92			17-29	17	HM WM	
3.3.4	2941	(AB5)33 (CF4)81 (TG5)4	69 106 110			13-16	21	HM WM	
3.3.4	3051	(AB5)348 (AC5)37 (BF2)31 (FO7)16 (TG5)77	67 69 94 110		825EW	15-29	41	HM WM	
3.3.4	3369	(AC5)36	69		820ER H	12	6	WM	
3.3.4	3945	(FO6)54,154 (FQ3)7	92F 110		910	17-20	18	HM WM	
3.3.4	4162	(FO6)116	110		910 RBR	14	12	HM	
3.3.4	4494	(JG2)167,204 gr. 150	95	1231	820IR	30	12	HM	
3.3.4	4813	(BE4)1	94			29	5	WM	
3.3.5	2083	(AC5)12 (BF2)33 (CF4)10	65 67 110		820ECR	10-22	40	HM WM	
3.3.5	2488	(BE3)16 (FQ3)40	1 67	1112 850 x 1	812 (1/2 INT)	15-20	18	HM WM	
3.3.5	2533	(AB5)91,94 (AD5)293,296 (BE2)51 (FP6)154 (FP7)1 (FQ3)8 (FQ4)59 (FR3)0	8 12 92 110		825EIW RBR RBRE CRR	8-16 (48)	80	HM	
3.3.5	2565	(AB4)10 (AB5)32 (FP6)138 (FZ1)25	79 95 110	1003	910 RBRIE	12-25	346	HM WM	
3.3.5	2711	(AB6)8 (AC6)30 (AD5)289 (AD6)5 (FO6)114,129,145 (FP7)12 (FQ4)59 (FR3)14 (FR4)9,10 (FZ2)25	2 69 92 92C 94 110		825EICR 825EIBUFF RBRI	9-13	157	HM	
3.3.5	2916	(AB4)20	65	65g		9.6	37	WM	

Fig. no.	Type	Provenance	Fabric	Dec.	Surface treatment	Dia.	%	Man.	Comments
3.3.5	2979	(AB4)23 (AD5)134,311 (CE4)47 (FQ4)112 (FR3)14	67 69 92 92C 110		820ER 825EIW 910	9.5-23	151	HM	
3.3.5	3110	(CF4)161 (FO6)15 (FQ4)112 (TG5)74 (ZH5)36,37,44	80 92 110		822R	12-20	70	HM	
3.3.5	3111	(CE4)7 (CF4)30 (ZH5)37	94 97 110		910	15-17	26	HM	
3.3.5	3130	(FT3)49 (TG5)52 (ZH5)60	32 94			14-20	12	WM	
3.3.5	3437	(FS3)11	92C			9	8	HM	
3.3.5	3462	(FR3)22	92		H820ER	12	6	WM	
3.3.5	3479	(AD5)215	110			8	27	HM	
3.3.5	3837	(AC5)126 (BE3)57 (CF4)17,88 (JG2)25 (TG5)29-105	92 94 110		825EW 910	10-24	35	HM	1 wonky
3.3.5	3849	(AC5)128	110			15	10	HM	
3.3.5	3938	(CF4)69 (FO6)121 (FP7)19,59 (FQ4)98	92 94 110			8-10	88	HM	
3.3.5	3949	(TG5)12,44	67			8-14	14	HM	
3.3.5	4154	(FO6)53,63	92		RBRIE	8-9	36	SW	999
3.3.5	4443	(JG2)184 gr. 244	131			13	11	HM	spade sherd
3.3.5	4602	(TG5)7	94			12	21	HM	
3.3.5	4623	(CE4)61 (FP6)109	110			6-11	42	HM	
3.3.5	4717	(FP7)12 (FZ2)22	110			7-10	42	HM	
3.3.5	4791	(GD3)32 gr. 55	33	1274	820ER	11	27	WM	
3.3.6	2000v	(BF1)13 (FT3)44	67 92C	851	910	26-27	13	HM	
3.3.6	2157	(AB4)1 (BE2)52,133 (BE3)10,16,18 (BF2)56 (BF3)9 (FQ4)2	25 67 69 92 94		825EIW	9-20	113	HM WM	
3.3.6	2167	(BE1)7 (BE2)38 (BE3)1,10,16,37 (BE4)29	1 67 69	1010	825CR	13-32	99	HM WM	
3.3.6	2171	(BE3)27 (BF2)31	25 69	1020x	825E	19	8	WM	
3.3.6	2188	(BD3)5 (BE3)10,18 (BF1)28 (BF3)8 (CF4)132	65 67 92 94		820IW	11-38	59	HM WM	
3.3.6	2281	(AC6)16 (BC4)1 (BE1)7 (BE2)48,67,85 (BE3)17,106,116,118 (FQ4)2 (FT3)44	1 67 69 80 92 94	1038 851? x 2	825EB 825EI 910	10-23	301	HM WM	post-firing hole
3.3.6	2476	(BE3)16	67			21	21	WM	
3.3.6	3108	(AC5)116 (ZH5)36	2 110			14-17	48	HM	
3.3.6	3140	(CF4)133 (GD3)1 (TG5)12 (ZH5)53	67 69 92 110			11-16	34	HM SW	
3.3.6	3148	(HA2)95 (TG5)5/4	67 92			13	12	HM	
3.3.6	3481	(AD5)217 (CF4)17,50 (TG5)46,112	92 106 110			11-16	67	HM WM	
3.3.6	3812	(AC5)126	92			14	5	HM	
3.3.6	3838	(AC5)126	92 110		825EICR	12	25	HM	
3.3.6	3840	(AC5)126 (CF3)27	92 92F		ext burnish	9-11	17	HM	
3.3.6	3855	(AD5)256	92			13	20	HM	
3.3.6	3867	(AD5)296	92		910	10	9	HM	
3.3.6	3915	(FQ4)7	92			11	7	HM	
3.3.7	2044	(AD5)246 (BE1)9,41,61 (BE2)32,50,85,103 (BE3)10,16,17,55,63, 106 (BE4)1,16 (BF1)27 (BF3)1,50,56 (FR3)12 (JC3)6	1 9 48 67 94 92 110	850 x 1 thickened ext vert lug	H820ER 820EBL 822CR RBRIE	10-18 (29)	316	HM WM	

Fig. no.	Type	Provenance	Fabric	Dec.	Surface treatment	Dia.	%	Man.	Comments
3.3.7	2277	(AD5)113,129,154 (AC5)68 (BE1)6 (BE2)32,52 (BF1)13 (CE4)61 (FO6)56	21 58 67 92 94 110	1016	825EBR 910 RBRE	11-27	160	HM WM	
3.3.7	2714	(BD4)16 (BE1)1 (BF2)51,56	1 67 94	thickened ext	820ER	16-19	63	HM	
3.3.7	2885	(BF1)26	94	8		18	85	HM	oven reuse
3.3.7	2886	(BF1)26 (JF2)53 (TG5)112	94 110	8	910	12-14	33	HM	
3.3.7	3501	(HA2)58,145E gr. 58	69			14	18	HM	spade sherd
3.3.7	4177	(FP6)21	110			11	75	HM	
3.3.7	4193	(FP6)37	110			8	21	HM	oil soaked
3.3.7	4482	(CE4)86 (CF4)113,134	92 94 110	262g		13-15	42	HM	
3.3.7	4640	(FP6)92,111	110		910	8-10	40	HM	
3.3.7	4647	(FO7)1 (FQ4)80 (FZ1)10	92 94 110		910	9-11	46	HM	
3.3.7	4738	(FP6)138	110		910	11	28	HM	
3.3.8	108	(BE2)158 (BE3)116 (BF1)6,57	2 67 69			17-34	38	WM	
3.3.8	2204	(BE1)41 (BE3)63,78 (BE4)9	1 67 92 94			13-18	42	HM WM	
3.3.8	2270	(BE2)103 (BE3)55 (BF1)4 (FR4)2	1 67 92		832R	16-26	46	HM WM	
3.3.8	3040	(BE2)32 (BF3)9 (ZH5)30	69 92 92C	1090g	822R	16	70	HM WM	
3.3.8	3539	(BE2)147 (BE3)33 (JE3)1	20 83 92	1136		20	16	HM	
3.3.8	4380	(CF3)13 (TG5)5/4	56 67L		822Y	22	21	WM	
3.3.8	4621	(TG5)12	110		825IR	31	14	HM	
3.3.9	2196	(BF3)8	80		822CR RBRE	35	6	WM	
3.3.9	2429	(AC5)53,59,68 (AD5)1,112 (BD3)5 (BE3)27 (TG5)12,91	1 65 67 69 80 92 94			18-36	79	HM WM	
3.3.9	2430	(AB5)68 (BE3)27 (BF2)51 (CF5)1	67 69			20-37	36	HM WM	
3.3.9	2462	(AB5)68 (BE2)156 (BE3)10 (CE4)2 (CF4)13,102 (FO7)3 (FS3)13 (TG5)35	1 79 92 94 95 110		820IE RBRIE 910	15-35	54	HM WM	
3.3.9	2515	(BE2)38 (CF5)1	67 94		822BR	34-39	13	WM	
3.3.9	2587	(AB5)68 (FS3)11 (FT3)2	69 93 110		910	19-29	24	HM WM	
3.3.9	2754	(BF1)61	67		820E	29	9	WM	
3.3.9	2973	(AB4)23 (FQ4)27	65 92			30-50	7	HM WM	
3.3.9	3067	(AD5)1	69		RBR TOP 825EW	28	11	WM	
3.3.9	3068	(AD5)1,7	65 67		820IW	36-52	19	WM	
3.3.9	3416	(AC5)68	65			17	7	WM	
3.3.9	3608	(CE4)1 (TG5)13	65			29-32	10	WM	
3.3.9	4369	(CF3)1 (CF4)1 (CF5)1 (TG5)1	69 94		820ECR 820EO 822R 822CR	25-50 (?)	30	WM	
3.3.9	4378	(CF3)13 (CF4)7	94		820EOR 822CR/P 825IR RBR	25-32	12	WM	
3.3.9	4389	(CF3)5	67			20	5	HM	
3.3.9	4404	(CE4)48 (CF4)18	67 94		822O 822O/W	30-40	20	WM	
3.3.9	4433	(TG5)1	67		820ECR	30	4	WM	
3.3.9	4435	(TG5)1	94			30	4	WM	
3.3.9	4573	(CF4)49	67			29	7	HM	

Fig. no.	Type	Provenance	Fabric	Dec.	Surface treatment	Dia.	%	Man.	Comments
3.3.10	2118	(BE2)31 (BE4)8 (BF1)31,45,61	2 67 69 94		820EW 832W	11-30	36	WM	
3.3.10	2119	(BD2)28,29 (BE1)8 (BE4)8 (CF3)5 (TG5)29	12 67 69 92 94		RBRE	17-31	38	HM WM	
3.3.10	2120	(AB6)8 (AC6)22,57 (AD5)134 (BE2)1	67 92 94		820EW 825EO 830IR/832W	16-36	147	HM WM	
3.3.10	2162	(BD2)23 (BE2)48 (BF3)9	67 69 92		822BEIGE RBRIE	11-25	40	WM	
3.3.10	2251	(BE3)10,78	67 77		825	19-24	18	WM	
3.3.10	2405	(AD5)207 (BE2)158 (BE3)26 (CE4)1,4 (FQ4)2,27	2 67 69 80 110 130	850	910	12-30	65	HM WM	
3.3.10	2442	(BD3)5 (BE2)32 (BE3)10 (BF3)9,58	67 69 80 94		825EIW 832W 8320W	13-36	40	HM WM	
3.3.10	2453	(AB5)32 (AC5)32,53 (AD5)161A (BE3)18 (CF3)13 (ZH5)89	67 69 80 92 93 94		822W	14-26	53	HM WM	
3.3.10	2486	(BE3)95 (TG5)117	94 95		802	25-40	8	HM WM	
3.3.10	2523	(BF1)56	67			21	9	WM	
3.3.10	2549	(BE2)103 (BF1)4	2 69		825EIW	16-17	19	HM WM	
3.3.10	2759	(BF1)75	69		RBRI	23	6	WM	
3.3.10	3007	(AB5)234 (AC5)129 (AD5)288 (FQ4)8 (FS3)6 (TG5)6	92 98 110		RBR TOP	22-36	27	HM WM SW	
3.3.10	3187	(FT3)22	2 65	1124	820EY 820EY	1-18	16	HM	
3.3.10	3293	(AC5)55,64,79 (CF3)8 (CF4)13 (CF5)1 (FQ3)40,58 (FR4)2 (TG5)1	67 69 92 93 94 94F 110		822R	10-30	59	HM WM	
3.3.10	3383	(AD5)112	94F		825EBR RBR	25	18	WM	
3.3.10	3919	(FP6)37 (FQ4)63	92C 110		RBR TOP RBRIE	25-26	16	HM	
3.3.10	3963	(FQ3)63	92		RBR TOP	27	4	HM	
3.3.10	4009	(TG5)91	94			8	24	WM	
3.3.10	4200	(CF5)1 (TG5)95	94		822Y	36	11	WM	
3.3.10	4223	(TG5)73,91,95	65 67 94		820ER RBR	8.5-10	104	WM	
3.3.10	4284	(TG5)96	67		820IW	25	8	WM	
3.3.10	4381	(BE1)18 (CF3)13 (TG5)94	25 92 94		825EIR	18-33	24	HM WM	
3.3.10	4400	(CF3)8	92C	1204	820IR 825EW	24	5	HM	
3.3.10	4437	(TG5)1	67			23	8	WM	
3.3.10	4464	(CF4)88	94	871? x 2 pre-firing	825EICR	10	5	WM	
3.3.10	4465	(CF4)88	94F			12	35	WM	
3.3.10	4496	(CF3)29	67	1220 833EBR	820ECR 820IW	23	5	WM	
3.3.10	4521	(CF3)30	94			13	5	SW	
3.3.10	4537	(CE4)85	94		RBR TOP	25	7	WM	

3.4. Open-mouthed jars

Hanging pots – note that the hanging holes also occur on some restricted forms (cf. Figures 3.3.1, 3.3.4 & 3.3.6). Wheel-made bowls with grooves by the rim. This section overall has inverted rims.

3.4.1 Open-mouthed jars

With variants of beading, with handles or lugs. For an approximate parallel to 2670x, 2695x and 3532x, see Mohamed Ahmed 1992, fig. 20 I D8e (late 7th to mid 6th centuries BC).

2679x: Mohamed Ahmed 1992, fig. 20 I D8a, early 8th to early 5th centuries BC (but without piecrust lug). A similar rim, ostensibly without the lug, but a more open form, is 2278x, 3.7.19.

3.4.2 Open-mouthed jars with complex rims and partial ribbing

2226x: Mohamed Ahmed 1992, fig. 18 IA23 late 7th to mid 6th centuries BC.

4316x: Mohamed Ahmed 1992, fig. 20 I D8d late 7th to mid 6th centuries BC.

3.4.3 Double-beaded inverted jar rims

2006x: Mohamed Ahmed 1992 fig. 16 IA15a, 7th century BC.

2649x: Probably had a ring-footed base, with the centre protruding below the rim, like 2650x (3.12.3).

2753x: This form is very irregular, hence the different angles shown in the drawing. Most likely an unintentional deformation at the pre-firing stage.

4411x: Nu.1 (5, 690-664 BC) fig. 4, 16-12-9 FHRW; Nu.72 (9, 623-593 BC) fig. 49, 18-1-128.

4615x: Mohamed Ahmed 1992, fig. 24 IIA10, 6th century BC.

3.4.4 Double-beaded rims, with vertical sides

2079x: Jacquet-Gordon no date, fig. 10.3, pre-30th Dynasty.

3.4.5 So-called pigeon pots

Possible rims and bases. Given the small aperture of the hole in the base (16mm in the case of 3290x, for example) the hole is there solely to allow for the circulation of air.

2668xa: Mohamed Ahmed 1992, fig. 16 I A18 late 7th to mid 6th centuries BC; French 2004, 97, Type 7, second half of the 6th century BC.

4301x: There is a good parallel in French 2004, 97 Type 7, a pigeon pot, dated to the second half of the 6th century BC, but the other rims and bases that appear to be pigeon pots have everted rims.

3.4.6 Deep bowls with beaded rims

Many with suspension holes, c. 4cm below the rim. These would normally occur in pairs, and might show wear from the rope. cf. Mohamed Ahmed 1992, fig. 20 I D8b (early 7th to early 5th centuries BC), which generally matches the type. See also Plate 3.8.2, showing wear from a strap between the hole and the vessel's rim.

2293xd: Ruffieux 2007, pl. 5.47 [27-05], Nile clay; Napatan.
2624x: Laming Macadam 1955 II, pl. XXXII.4 [2146], Napatan.

2664x: Laming Macadam 1955 II, pl. XXXII.5 [2010], Napatan (includes the pie-crust lug).

3210x: Note that the zigzag wear marks on the rim may have been caused by the string or leather thong used to suspend the vessel.

3.4.7 Open-mouthed wheel-made jars with beaded rims, various inclinations

3414x: Mohamed Ahmed 1992, fig. 16 I A11 late 7th to early 5th centuries BC.

4576x: Jacquet-Gordon no date, fig. 10.4, before the 30th Dynasty.

3.4.8 Basins with beaded rims, vertical sides and horizontal or vertical handles

2583x: Mohamed Ahmed 1992, fig. 27 III A3 mid 6th to late 5th centuries BC.

3.4.9 Deep basins with ledge rims, some with handles

2932x: Mohamed Ahmed 1992, fig. 22 I D28, 7th century BC.

3.4.10 Basins with vertical or inverted rims

4444x: Aston 1999, pl. 116.3052, late 3rd to 2nd century BC (with two handles). Also, *ibid*, pl. 113.2989; Orzechowska 2003, pl. 7b, Meroitic. Another form, 4821x (3.7.24) looks like the same type of ware.

3.4.11 Storage jars

Both hand and wheel-made. Some have four handles, not set in pairs, but one at each quadrant of the vessel. For a variety of rims similar to 4650x, see 3.8.9. Note that two of the jars (2719xb and 2792x) have one hole drilled near the base (two in the case of the latter). The parallel from Nuri does not have any.

+**2792x:** Nu.13 (23, 397-362 BC) fig. 172, 17-4-866; Laming Macadam 1955 II, pl. XXXII.2b [2008], Napatan.

4649x: The example from (FO6)157 is pot D, found in Room VII. The context of the other example from Building F1 has been lost; its diameter is much larger, at 46cm.

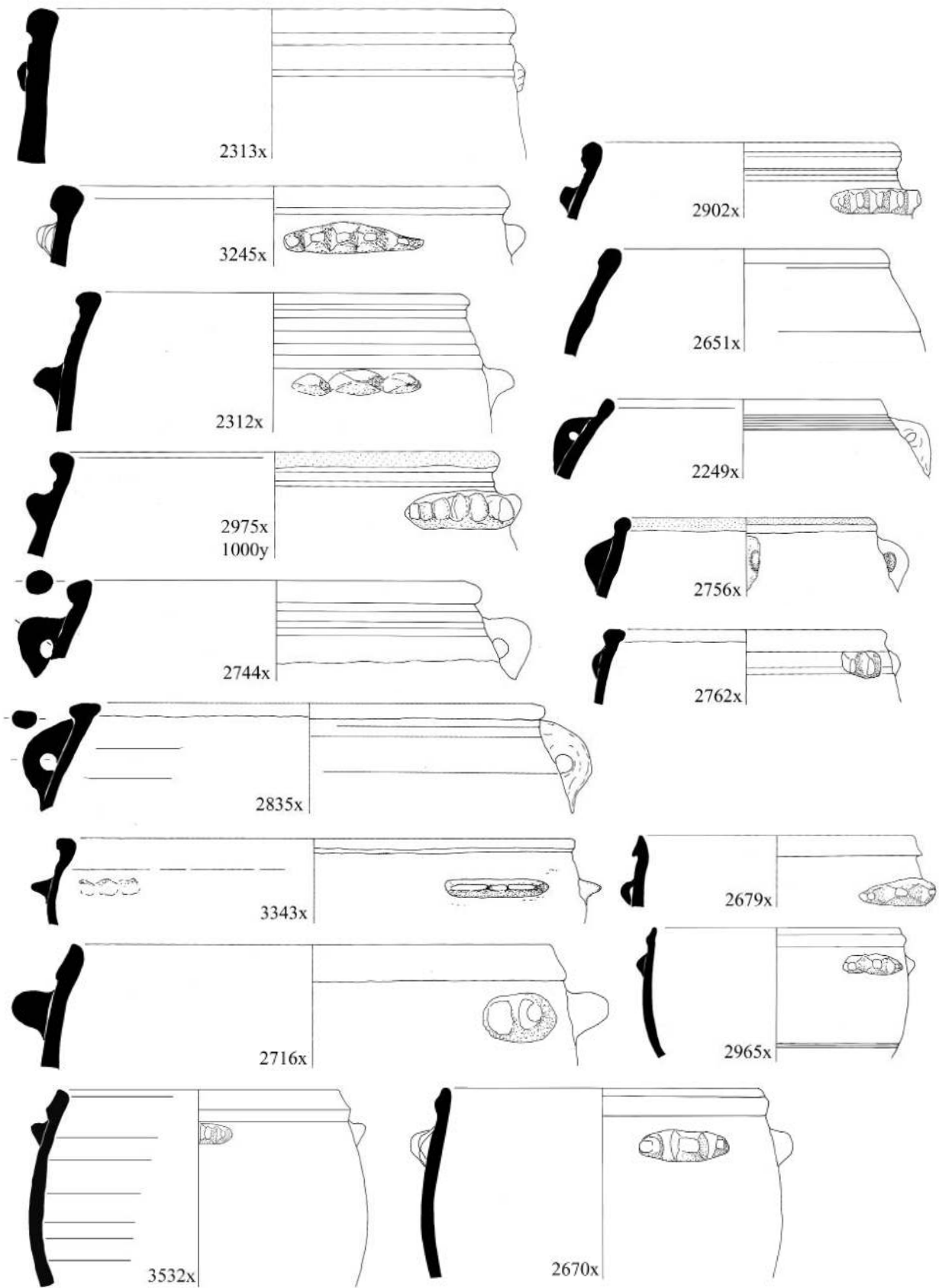

Figure 3.4.1. Open-mouthed jars with variants of beading, with handles or lugs (scale 1:4).

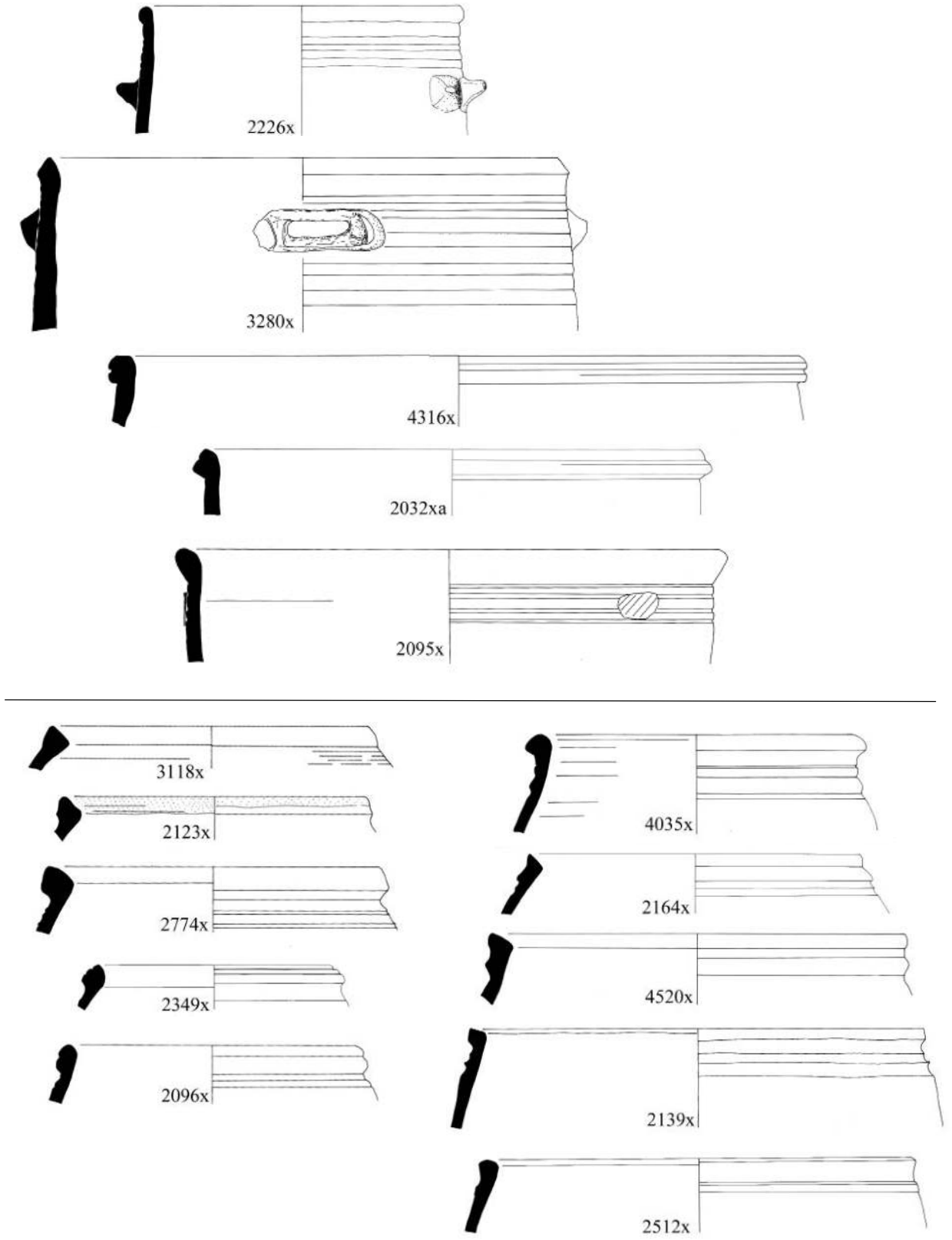

Figure 3.4.2. Open-mouthed jars (scale 1:4).

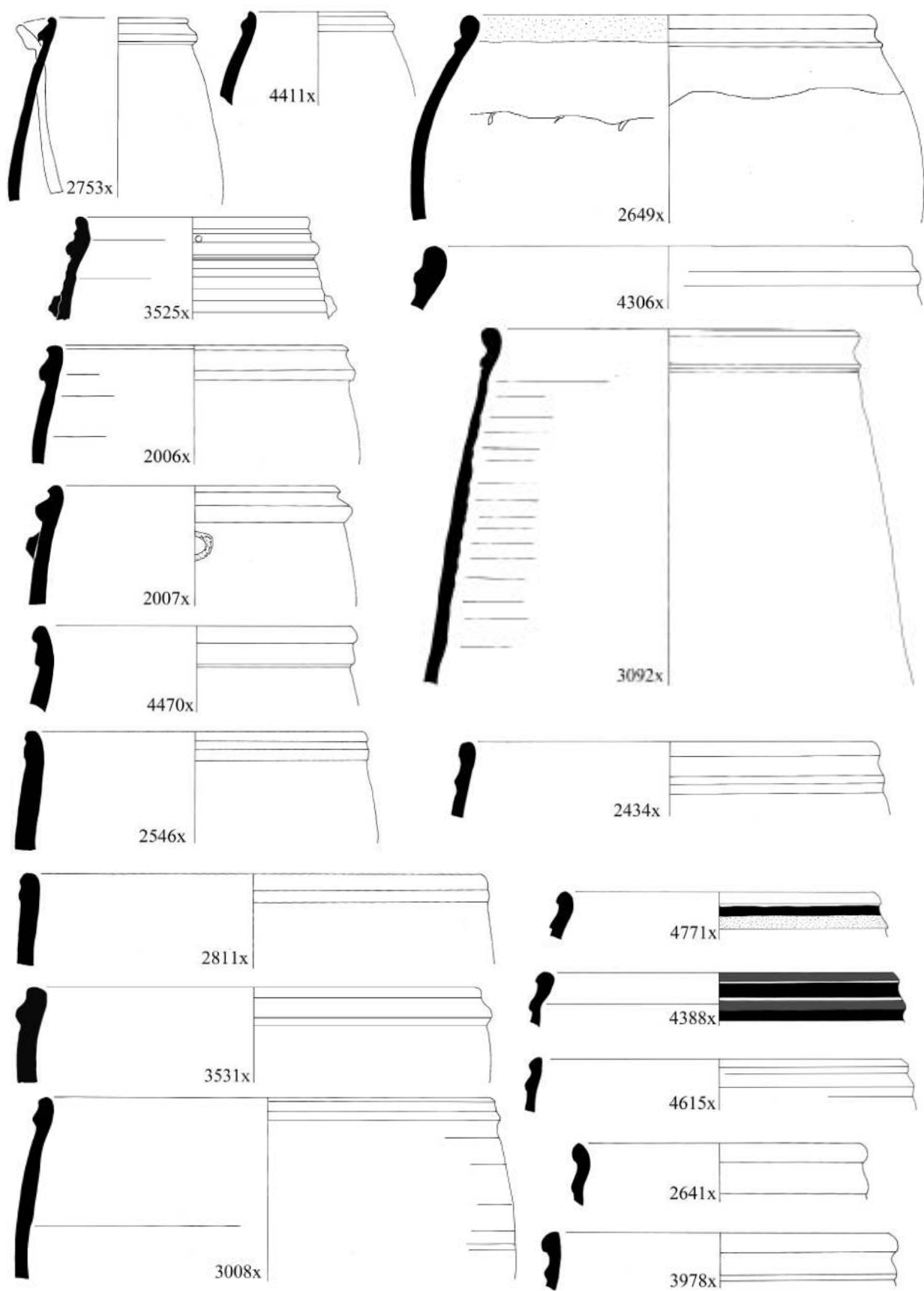

Figure 3.4.3. Double-beaded jar rims (scale 1:4).

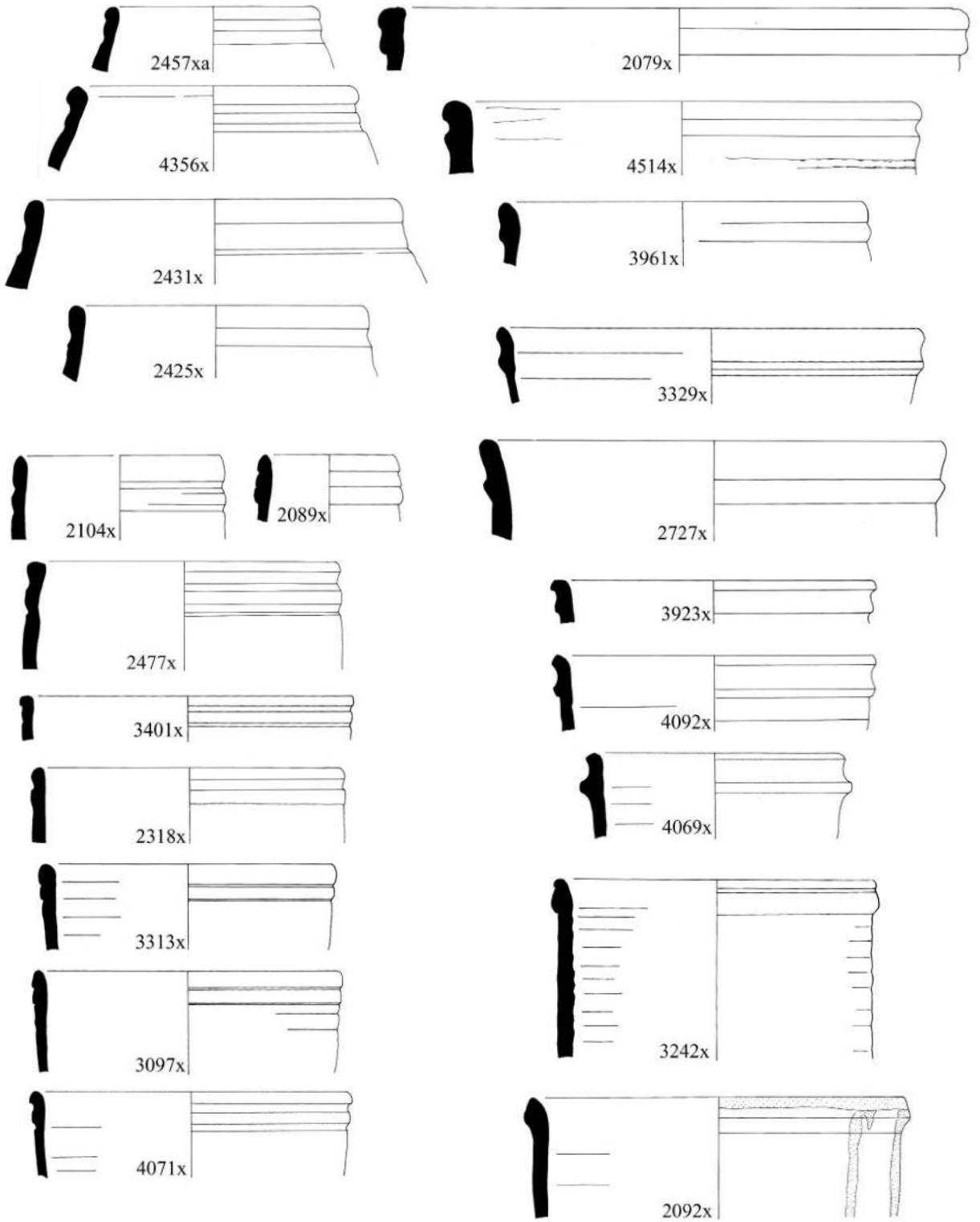

Figure 3.4.4. Double-beaded rims, vertical sides (scale 1:4).

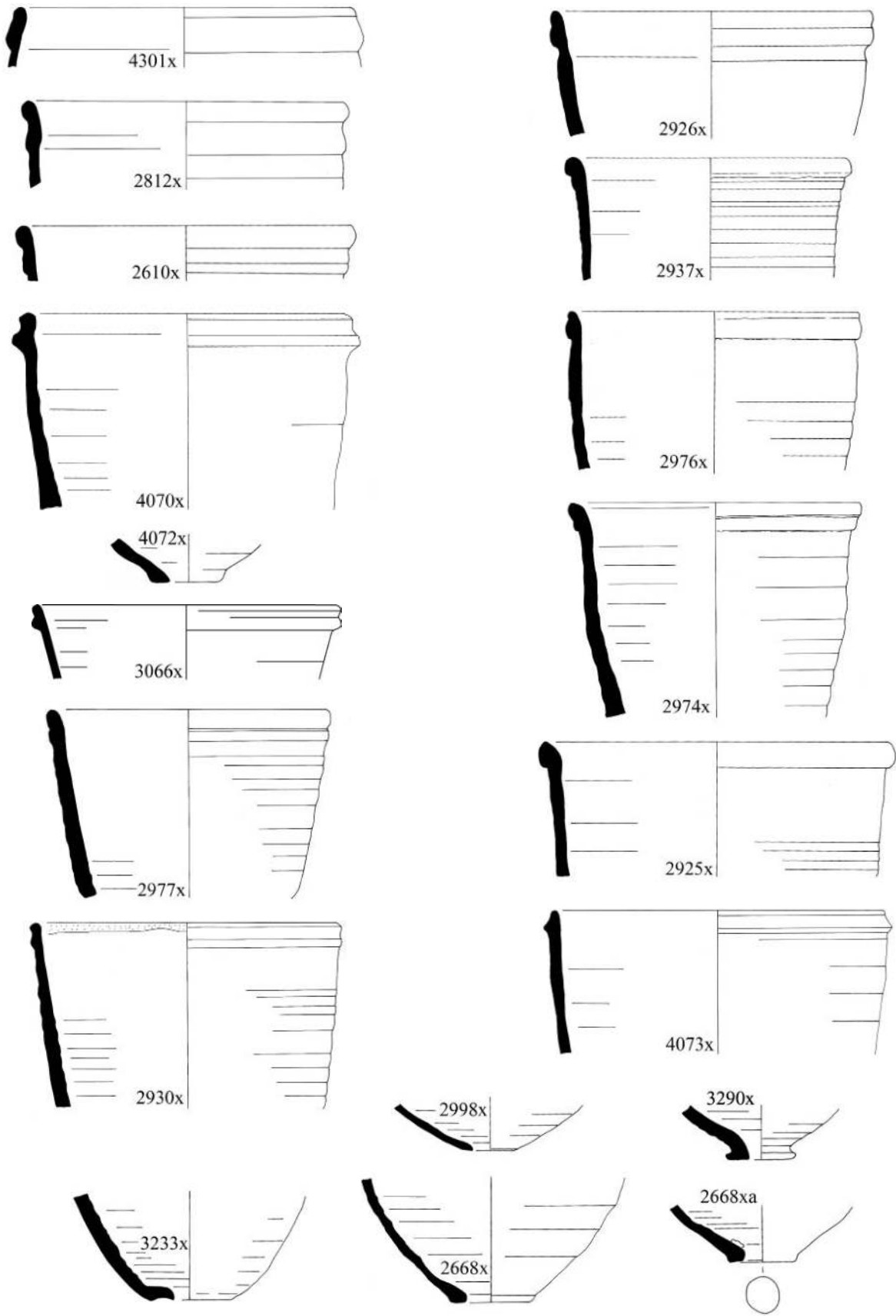

Figure 3.4.5. So-called pigeon pots, possible rims and bases (scale 1:4).

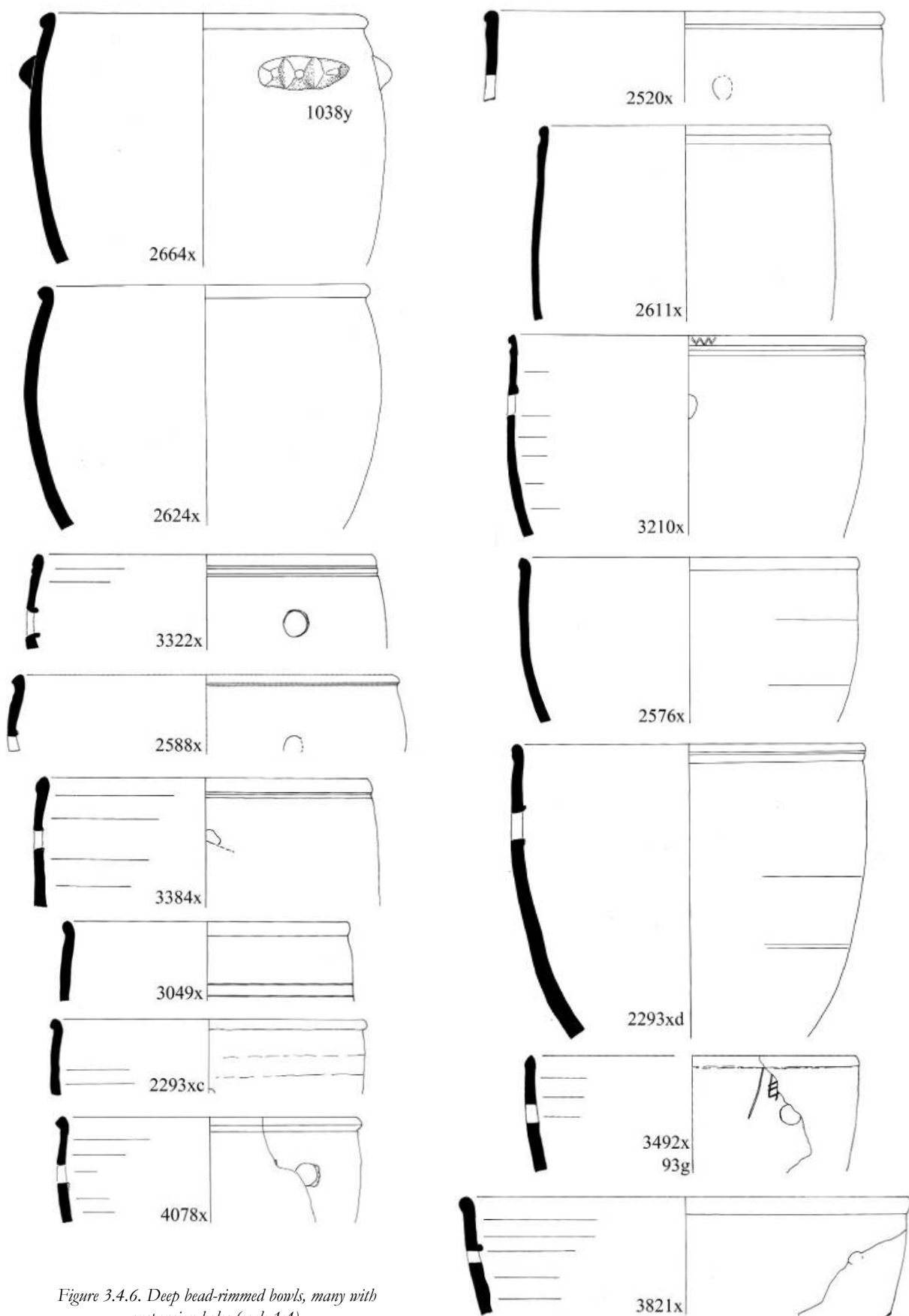

Figure 3.4.6. Deep bead-rimmed bowls, many with suspension holes (scale 1:4).

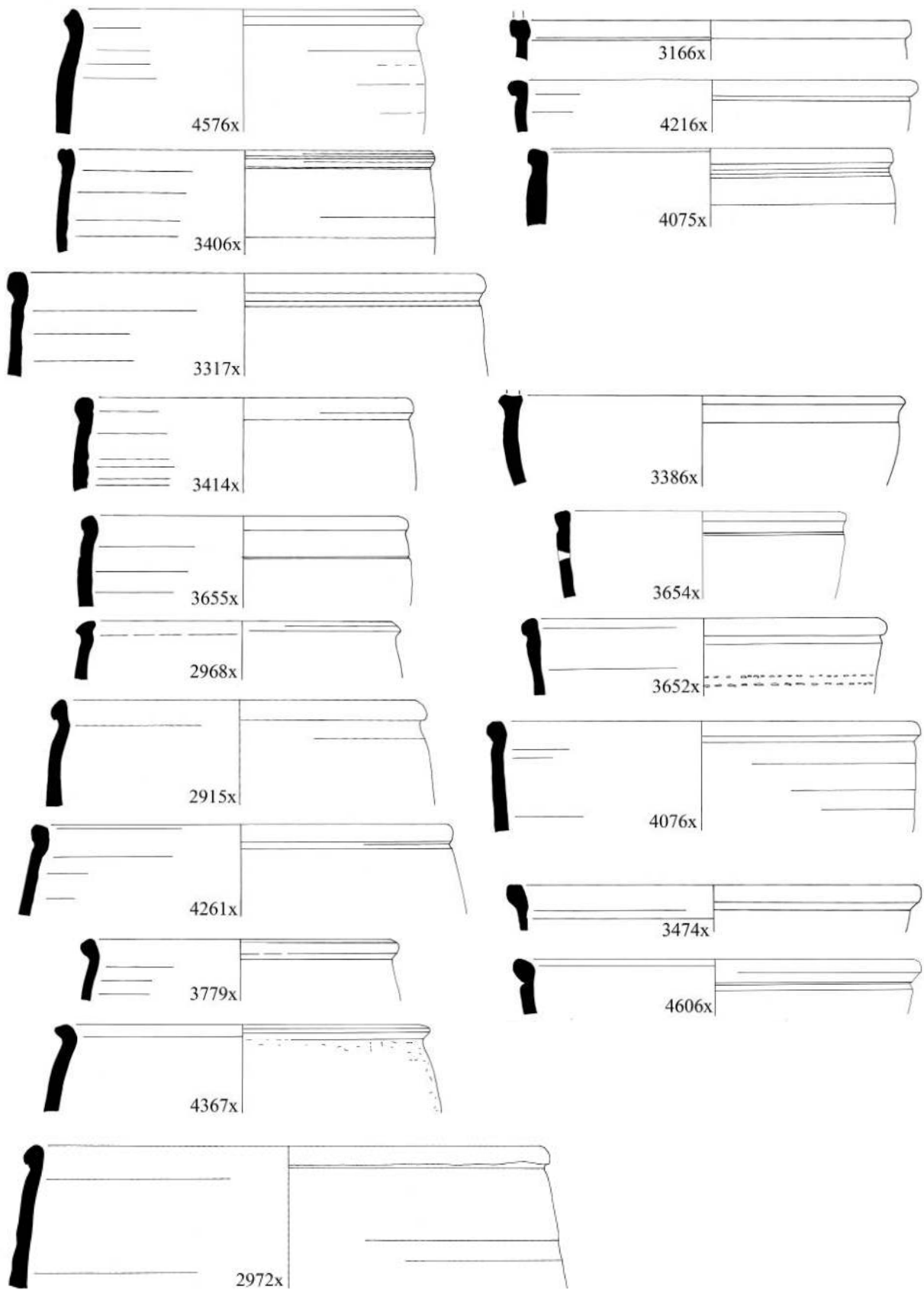

Figure 3.4.7. Open-mouthed wheel-made jars with beaded rims (scale 1:4).

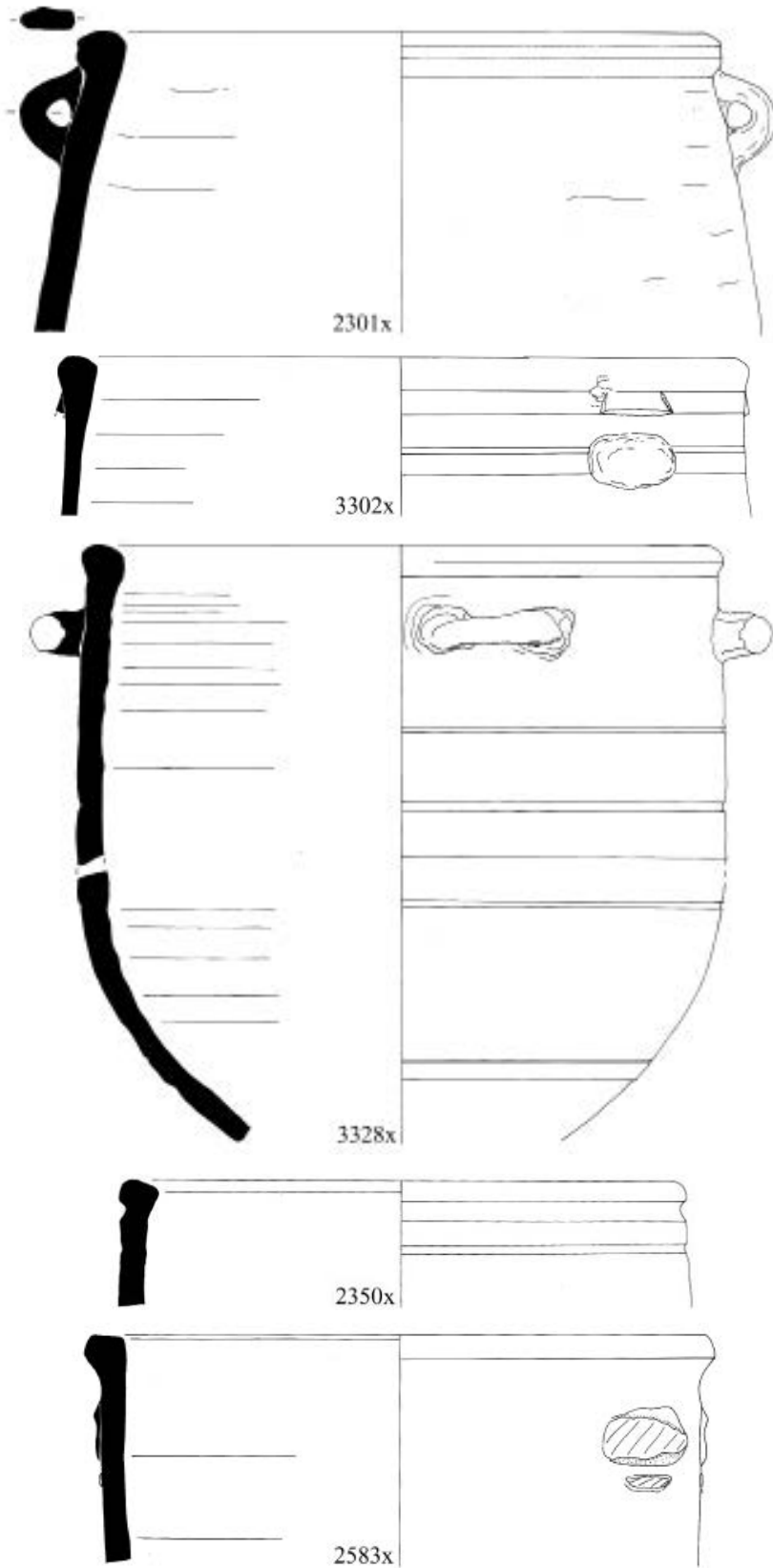

Figure 3.4.8. Basins with beaded rims, vertical sides and horizontal or vertical handles (scale 1:4).

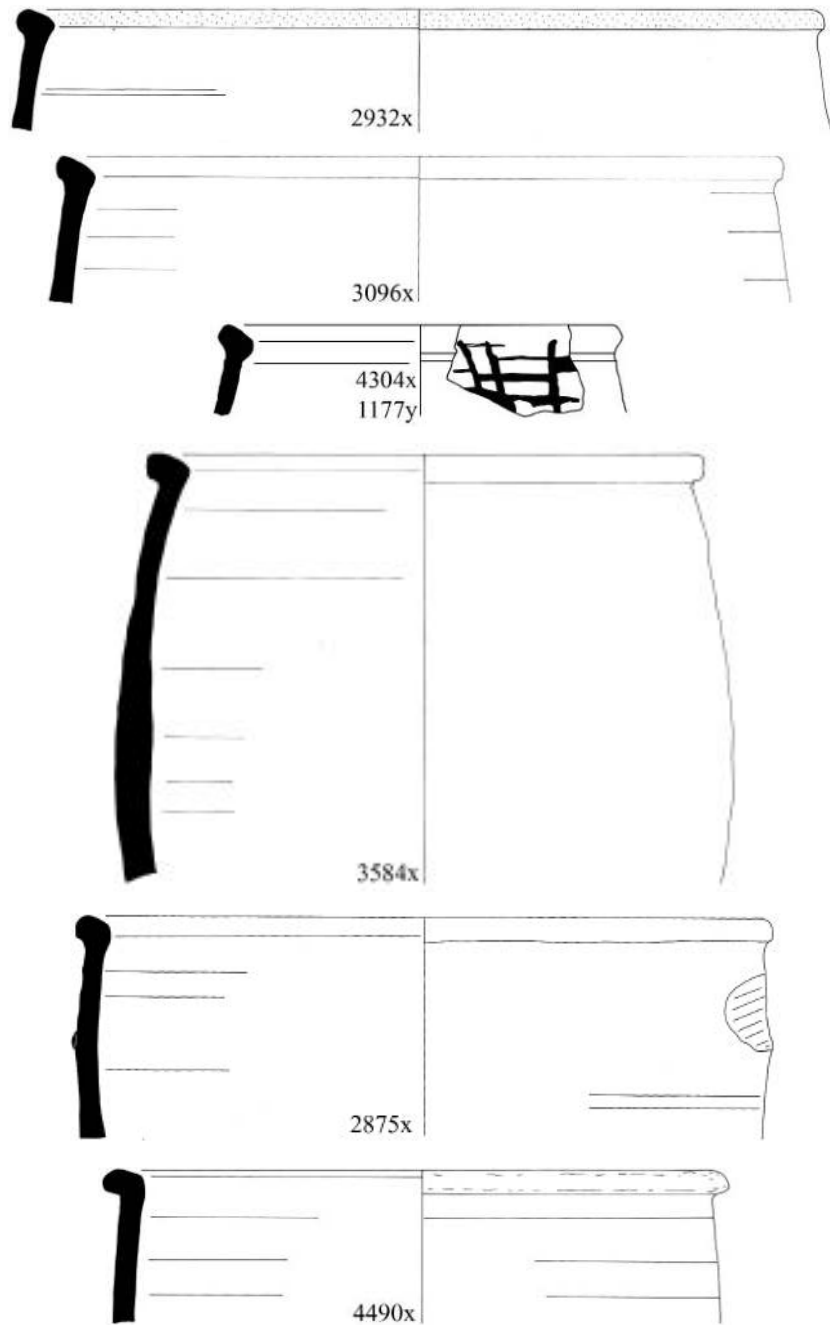

Figure 3.4.9. Deep basins with ledge rims, some with handles (scale 1:4).

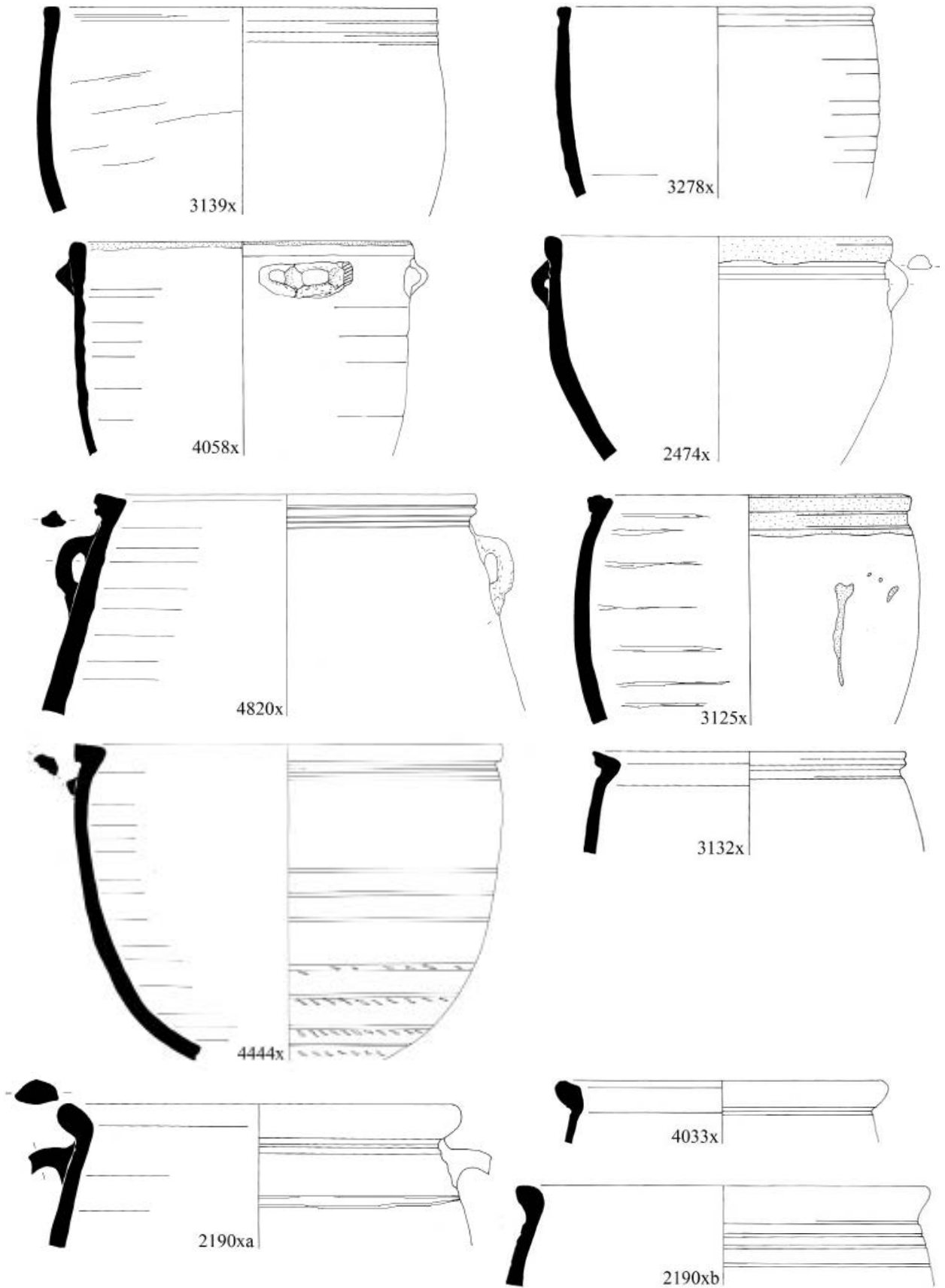

Figure 3.4.10. Basins with vertical or inverted rims (scale 1:4).

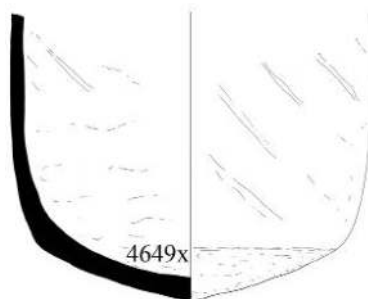
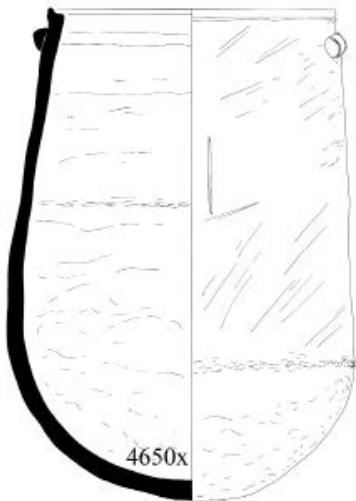
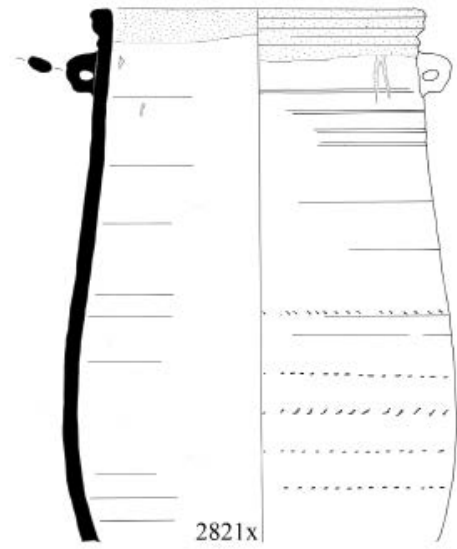
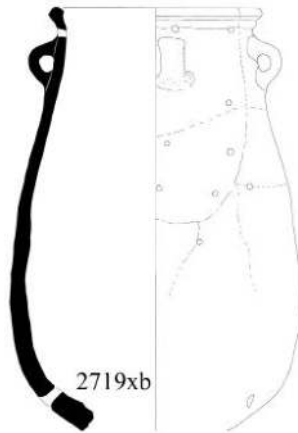
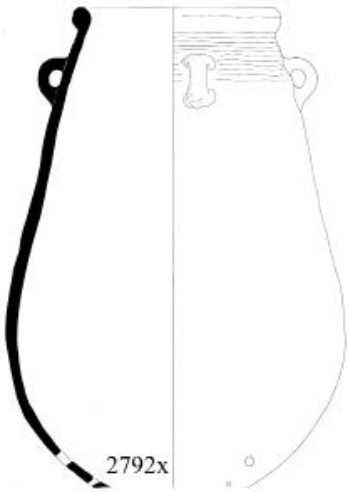
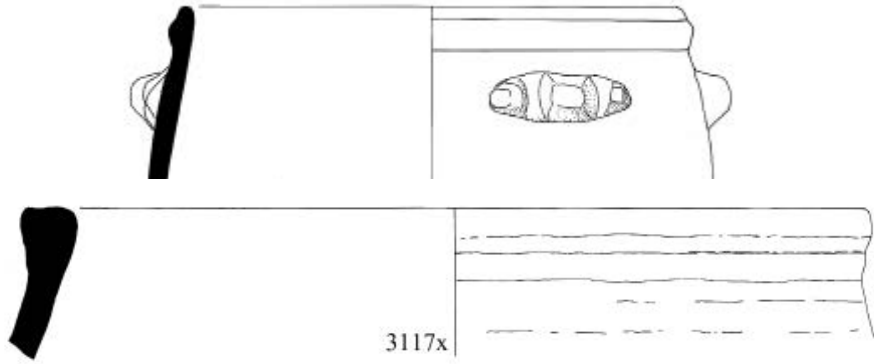

Figure 3.4.11. Handmade and wheel-made storage jars. 2719b, 2792, 2821, 4649 and 4650 are at scale 1:8, others at 1:4.

3.4.11
2792x



4650x
3.4.11

Plate 3.4.1. Examples of large storage jars. Note especially the presence of two holes near the base of 2792x and the lid-seating on 4650x.

TABLE 3.4. OPEN-MOUTHED JARS.

Fig. no.	Type	Provenance	Fabric	Dec.	Surface treatment	Dia.	%	Man.	Comments
3.4.1	2312	(AD5)35 (BE2)10,109,110	65 67	1000 1038	820EW 820IW	29-45	26	WM	
3.4.1	2313	(BE3)1 67	-		820E	34	16	WM	
3.4.1	2651	(AB4)6,7,9	1 11 94			20-34	27	WM	
3.4.1	2670	(AB4)10,11 (AD5)1	67 69 83	1038	820EW	22-36	44	WM	
3.4.1	2679	(AB4)10,23 (CF3)13	67 92	1000	825EBR RBR	20-25	32	WM	
3.4.1	2716	(BE1)61 (CE4)4	94	1038		35	13	WM	
3.4.1	2744	(BF1)28	67	850 x 1		18	16	WM	
3.4.1	2756	(BF1)72	94		RBR	18	6	HM	
3.4.1	2762	(BF2)56	67	1038		20	11	HM	
3.4.1	2835	(AC6)23 (CF4)1	67 69			26-35	26	WM	
3.4.1	2902	(BD2)26	94	1000		22	16	WM	
3.4.1	2965	(AB4)23 (AC5)0 (AD5)98,127	92	1000		14-18	36	WM	
3.4.1	2975	(AB4)23 (CE4)4	69 94	1000	RBR TOP	24-32	13	WM	
3.4.1	3245	(AD5)49	94	1000	822W	33	12	WM	
3.4.1	3343	(AD5)0,154	94 94L	1000 1131	822W	27-37	13	WM	
3.4.1	3532	(HA2)135,227 gr. 207	79	lug	820IW	20	31	WM	
3.4.2	2032a	(BE1)73 (BF2)33	67 80		822R 830ECR	17-38	14	WM	
3.4.2	2095	(BD2)23,28,32,34,45 (BF3)56	25 67 69 92 94		820EW 822R 822RO 822W	21-40	61	WM	
3.4.2	2096	(BD2)94 (BF3)56	69 94		CRBRIE	21	22	WM	
3.4.2	2123	(BE2)155 (BF2)1	67		832CR 822Y RBRIE	16-22	17	WM	
3.4.2	2139	(BE2)25 (BE3)10 (BF2)56	17 67 94	1038	RBRI	25-47	15	HM WM	
3.4.2	2164	(BF2)51 (BF3)38,50 (TG5)74	67	850 x 1	810I 822CR	20-28	39	WM	
3.4.2	2226	(BC3)2 (BD3)9 (BF3)17	80 92 94	lug	820EP 822R (BL)825IP	23-24	28	WM	
3.4.2	2349	(BE3)17	67		832P	22	7	WM	
3.4.2	2512	(AB5)20	65		822W	32	7	WM	
3.4.2	2774	BD4 16 (FQ4)27	67 71			24-40	23	HM WM	
3.4.2	3118	(ZH5)37	69		822R	25	9	WM	
3.4.2	3280	(HA2)248 gr. 215	67		820EW	37	8	WM	
3.4.2	4035	(TG5)73	92			23	17	WM	
3.4.2	4316	2000 0	106		822O	-	-	WM	
3.4.2	4520	(CF3)31	92		820IR	30	4	HM	
3.4.3	2006	(AB5)354 (AD5)133,160 (BC3)2 (BD2)28,29,71,81 (BD3)9,28 (BE1)73 (BE2)48,70,71 (BF1)11,56 (BF2)1 (BF3)9,38,58 (BE4)60	65 66 67 69 80 92 94	1003 1038	825EICR 825EIW	(9)15-36	213	WM	
3.4.3	2007	(AC6)1 (AD5)134 (BE2)17 (BE3)10 (BF2)1 (TG5)1	67 93 94	850 x 1 lug	822CR 825ER	15-25	59	HM WM	
3.4.3	2434	(BE3)27	67	850		30	8	WM	
3.4.3	2546	(BE2)103	80			25	5	WM	
3.4.3	2641	(AB4)15	69			21	9	WM	
3.4.3	2649	(AB4)6	69 93		825EIW 825EIR/R	21-30	36	WM	898 B 2650 3.12.3?
3.4.3	2753	(BD2)28,70,101 (BF1)57	65 94 97		820IW	10-21	56	WM	wonky?
3.4.3	2811	(AB6)13	67			34	6	WM	

Fig. no.	Type	Provenance	Fabric	Dec.	Surface treatment	Dia.	%	Man.	Comments
3.4.3	3008	(AB5)239	67			33	7	WM	
3.4.3	3092	(AD5)4	69			26	26	WM	
3.4.3	3525	(HA2)215 gr. 269	67	850		20	10	WM	
3.4.3	3531	(HA2)227 gr. 207	67		820IW	40	4	WM	
3.4.3	3978	(CF3)5 (CF4)20 (FQ3)42	67 92 94		820EBL 820IW	23-25	17	WM	(FQ3) from brick
3.4.3	4306	(TG5)29	67			30	9	WM	
3.4.3	4388	(CF3)5	94		820ER 820IR	26	8	WM	
3.4.3	4411	(CF4)62,97,104 (FO6)172	92 94L 110			10-15	42	HM	
3.4.3	4470	(BF2)31 (CF3)12	67		822CR/R	23-26	15	WM	
3.4.3	4615	(TG5)4	94		820EIR	27	4	WM	
3.4.3	4771	(JD2)51	94	831BR/R/BR	820EP	23	7	WM	
3.4.4	2005	(AB4)4,6,7 (BD3)46 (BF1)6 (BF2)1	69 77 88 92 93		820EW 822BF 822R 822W	10-12	44	WM	
3.4.4	2079	(AB5)1 (AC5)49 (BF2)31	65 67 71		820EW\ 825EIR(P) 830EW	23-42	25	WM SW	
3.4.4	2089	(BE2)23 (BE3)1 (BE4)63 (BF3)50 (FR3)1 (FS3)13	25 65 66 67 71 92 92C		820ER 830ECR	9-46	33	HM WM	
3.4.4	2092	(BE4)60 (BF1)56 (BF3)50	67 69 93	dribble	RBRE	26-35	16	WM	
3.4.4	2104	(BC4)1 (BE3)10 (BE4)9 (BF3)52	69 80 94	dribble	830ECR RBRE	8-25	38	HM WM	
3.4.4	2318	(AB4)10 (AB5)41A (AD5)87 (BF3)38	67 67L 69 92 94			20-30	28	HM WM	
3.4.4	2425	(BD2)28,71 (BE1)6 (BE4)19	2 67 92 94	dribble	820EIW	11-20	46	HM WM	
3.4.4	2431	(BD2)71 (BE3)27 (FQ3)42	25 65 69 80		800I 822CR 825ER	11-25	37	HM WM	(FQ3) from brick
3.4.4	2457a	(BE3)10 (TG5)5/4	67 94			12-14	22	HM WM	
3.4.4	2477	(BD2)28 (BE1)6 (BE3)16 (CE4)1 (FT3)2 (TG5)29	65 67 69 92 93 94		820EW 825EIP 825EIR	22-33	56	HM WM	
3.4.4	2727	(AB4)31 (BE2)73	92 94		820IR	19-32	28	WM	
3.4.4	3097	(AD5)7	67			20	16	WM	
3.4.4	3242	(AD5)28	89			22	23	WM	
3.4.4	3313	(AD5)73	65			20	7	WM	
3.4.4	3329	(AD5)107	94			29	9	WM	
3.4.4	3401	(AC5)65	92F			23	3	WM	
3.4.4	3923	(FQ4)63	130		820EP 820IW	22	4	WM	
3.4.4	3961	(FQ3)40	93			25	7	WM	from brick?
3.4.4	4069	(TG5)73,91	92			17	12	WM	
3.4.4	4071	(TG5)73	92			22	19	WM	
3.4.4	4092	(CF4)20 (CF5)1 (JG2)1 (TG5)74,94	67 93 94 94F		820IW	18-24	24	WM	
3.4.4	4356	(CF4)1 (TG5)1	67 94F 110			10-24	48	WM	
3.4.4	4514	(CE4)71	94			32	4	WM	
3.4.5	2610	(AB5)43,66,91,94	67 92			20-32	31	WM	
3.4.5	2668	(AB4)23 (AD5)1 (TG5)73	65 92 93 94			2.5-4.5	456	WM	
3.4.5	2668a	(AB4)10	94			2.5	100	WM	
3.4.5	2812	(AB4)23 (AB6)13 (BD2)49	69L 92Q 94		822W	23-27	61	WM	
3.4.5	2925	(AB4)28 (TG5)1	93 94		820EP 825EW	17-25	28	WM	
3.4.5	2926	(AB4)28 (AD5)107	67 94			23-24	75	WM	
3.4.5	2930	(AB4)31 (TG5)6	67 92			22	24	WM	
3.4.5	2937	(AB4)31	83			20	33	WM	

Fig. no.	Type	Provenance	Fabric	Dec.	Surface treatment	Dia.	%	Man.	Comments
3.4.5	2974	(AB4)23	-		825EBR	21	41	WM	
3.4.5	2976	(AB4)23 (FQ4)1 (TG5)65,73	80 94		822EW 825EW	17-33	63	WM	
3.4.5	2977	(AB4)23	25L 67			20-28	60	WM	
3.4.5	2998	(AC5)13 (AD5)134 (TG5)4	69 94			2.5-3	103	WM	
3.4.5	3066	(AD5)1 (TG5)73	67 92			20-21	15	WM	
3.4.5	3233	(AD5)67 (TG5)94	65			2.5	57	WM	
3.4.5	3290	(AC5)45	92			5.4	100	WM	dented
3.4.5	4070	(TG5)73	92			23	37	WM	
3.4.5	4072	(TG5)73,91	92			2-3	115	WM	
3.4.5	4073	(TG5)5/4,87	92 94		820IW	14-24	44	WM	
3.4.5	4301	(TG5)75	94		820IW 825ER	24	6	WM	
3.4.6	2293c	(AB6)1 (CF3)13	69 110	851		23-28	20	WM	
3.4.6	2293d	(AB5)66 (AC5)49 (AD5)117	65 67 93	851		25-26	84	WM	
3.4.6	2520	(AB4)28 (AB5)14,29,92 (AC6)22 (AD5)167 (TG5)7	65 67 69 76 79 80 94F	850 851		20-37	125	WM	
3.4.6	2576	(AB4)28 (AB5)25,68,273 (AC5)49 (AD5)21 (FQ3)42 (FP7)31	65 66 67 69 93	850	825EBR 825EIW	19-34	97	HM WM	
3.4.6	2588	(AB4)5 (AB5)68 (AD5)129	65 83	851		21-31	22	WM	
3.4.6	2611	(AB4)10,14,33 (AB5)65,345 (AC5)12 (AD5)67,87,88,198 (TG5)44,73	65 67 69 92 93 94	851	825EBL	18-33	127	WM	
3.4.6	2624	(AB4)7,11,23,33 (AB5)59,66,288 (AC5)17 (AC6)14,23 (BE1)19 (CE4)1 (CF5)1 (FR3)0 (JF1)24 gr. 23 (TG5)73	65 67 69 80L 83 92 94 95 110	851	820ER 820EW 825EW	15-33	147	HM WM	
3.4.6	2664	(AB4)10 (AC5)34	67	1038	820IW RBR 822W	22-23	43	WM	
3.4.6	3049	(AB5)347 (AC5)37 (AD5)134 (TG5)1,73	67 92 94	850	820EW 822R	21-35	55	HM WM	
3.4.6	3210	(AD5)60,61 (TG5)73	65 67 94F	851		26-31	30	HM WM	wear marks/ R
3.4.6	3322	(AC5)51	94F	851		25	4	WM	
3.4.6	3384	(AD5)112	94	851		24	43	WM	
3.4.6	3492	(AD5)198	94	93g 851		-	1	WM	
3.4.6	3821	(AD5)264	67	851		33	9	WM	
3.4.6	4078	(TG5)1,73	94 94F	851		20-22	26	WM	
3.4.7	2915	(AB4)20 (TG5)1	92			25-26	15	WM SW	
3.4.7	2968	(AB4)19	72			17	6	WM	
3.4.7	2972	(AB4)23	92			35	7	WM	crude
3.4.7	3166	(CF3)13	92 94	850 x 1	820IO 820EYR	29-32	14	WM	
3.4.7	3317	(AD5)87	67			34	7	WM	
3.4.7	3386	(AD5)112	92			29	6	WM	
3.4.7	3406	(AD5)162	80		825EIBR	27	20	WM	
3.4.7	3414	(AB5)183 (TG5)91	69 94		825EI	19-24	15	WM	
3.4.7	3474	(AD5)207	17			30	9	WM	
3.4.7	3652	(TG5)18	93	855E		25	10	WM	

Fig. no.	Type	Provenance	Fabric	Dec.	Surface treatment	Dia.	%	Man.	Comments
3.4.7	3654	(FZ2)22 (TG5)18	93 110		RBRIE	16-23	15	HM WM	
3.4.7	3655	(TG5)18	67 93			27	8	WM	
3.4.7	3779	(AD5)207	80		825EW DRIB- BLE	22	23	WM	
3.4.7	4075	(TG5)91	94			27	6	WM	
3.4.7	4076	(TG5)29-105,73	93 94F		822CR	25-31	26	WM	
3.4.7	4216	(CF4)62 (TG5)4,102,112	94 106			17-18 (29)	16	WM SW	
3.4.7	4261	(TG5)89	94F	851 x 2		33	6	WM	
3.4.7	4367	(CF3)1	92			26	7	WM	
3.4.7	4576	(CF3)2	94		825EIR	25	17	SW	
3.4.7	4606	(TG5)17	67			29	7	WM	
3.4.8	2301	(AB4)7 (AB5)24 (BE1)7,63 (FR3)1	1 11 67 92	1001		36-53	53	HM WM	(AB4) 999 (AB5)
3.4.8	2350	(BE3)16 (BE4)17 (BF2)51	67 69 94	850	822P	29-34	24	HM WM	
3.4.8	2583	(AB5)68 (FS3)11	17 92		820ER	22-36	45	HM WM	
3.4.8	3302	(AD5)7	67		822W	39	17	WM	
3.4.8	3328	(AD5)102 (TG5)73	67 97		820EP	35-36	32	WM	
3.4.9	2875	(AB5)212 (CE4)1	67L 80		820EP	24-39	16	WM	HS
3.4.9	2932	(AB4)31 (AD5)278 (CE4)2 (CF3)49 (FQ3)42 (FQ4)5,8 (FS3)6 (TG5)1	67 92 94 110		RBR TOP	22-45	58	HM WM	
3.4.9	3096	(AD5)7 (FS3)13	67 110			30-38	18	HM WM	
3.4.9	3584	(JE3)54 P2	106		820EO 820IW	30	7	WM	very abraded
3.4.9	4304	(TG5)75	94	1177		22	9	WM	
3.4.9	4490	(CE5)5	94			31	9	WM	
3.4.10	2190A	(AB4)23	67		825EY RBR TOP	31	17	WM	
3.4.10	2190B	(BC3)2 (BF1)2,33 (BF3)8 (CF4)20	67 69	700E	822gr.	15-31	30	HM WM	
3.4.10	2474	(BE3)16 (BF1)56	69 92		825EIR	13-26	121	WM	
3.4.10	3125	(ZH5)44	92		H820IR/ 825IR	21	15	WM	
3.4.10	3132	(CF4)74 (ZH5)82	80 94		H820IR	23-26	17	WM	
3.4.10	3139	(FS3)3 (FT3)1 (JD2)38 (ZH5)53	92 94C 110			20-45	20	HM	
3.4.10	3278	(AC5)49 (TG5)87	69 94			23	14	WM	
3.4.10	4033	(CE4)37 (TG5)73,87,91	130 132		825EP	9-24	39	WM	
3.4.10	4058	(TG5)73	94	1000		25	40	WM	
3.4.10	4444	(JG2)184,185,224, 241 gr. 244	92F	855E	820IGR/CR	32	28	WM	
3.4.10	4820	(JD2)80 -	92			28	18	WM	
3.4.11	2719b	(BF1)25? B12 RM 20	-	850		22.5	50	HM	4 H, base hole, reused as oven
3.4.11	+2792	(BD2)45	94		820EBR	22	27	WM	4 H, 2 holes in base
3.4.11	2821	(AB5)32,35	76	855E	RBRIE	35	74	WM	
3.4.11	3117	(ZH5)37	71		825EW	50	7	HM	
3.4.11	3530	(HA2)227 gr. 207	89			26	18	WM	
3.4.11	4649	(CF3)74 (F)- (FO6)157	92 110		820ER 825IR	28-46	300	HM	base made separately
3.4.11	+4650	(CE4)30 (CF4)125	94	2 lugs	822BR 825ECR	31	148	HM	made in 3 sections

3.5. Miscellaneous open-mouthed jars

Wide-mouthed, mostly wheel-made jars. Flanged, ring-footed jars with ‘buttresses’ under the flange. Bell jars with everted, more or less beaded rims. Overall everted rims.

3.5.1 Deep jars with beaded rims, occasionally (?) with handles

2715x: Bar.12 (27, 322-315 BC), fig. 4, 16-2-417.

3.5.2 Buttressed ledge rim basins and similar forms minus the buttress; with ring-foot bases

+2029x: Mohamed Ahmed 1992, fig. 15, I A3c.; Aston 1999, pl. 113.3003 and pl. 116.3059; Aston places it in the late 3rd to 2nd centuries BC, while Mohamed Ahmed dates it to the late 7th to mid 6th centuries BC, which fits better with the chronology at Kawa, where one of the examples was found in (BD2)100, a deep sondage level, predating Building B14. However, the form seems too distinctive and relatively unusual to span such a wide period. See also French 1992, 86, 89, fig. 13, where a similar form, but without the buttresses, (i.e. similar to 2901x) is dated to the 6th century BC. Could this type possibly have been used as chamber pots (hence the support for the flange)? A very distant parallel in medieval Palermo has a vaguely reminiscent shape and is thought to have been used as a chamber pot (Sacco 2020, 81, fig. 3.11). The example illustrated in Plate 3.5.1 appears to have had its rim systematically chipped away. **2795x:** Boulet and Defernez 2014, fig. 31-2.B, late 25th to early 26th Dynasties.

3.5.3 Jars with ‘S’-shaped profile, various types

Griffith 1923, pl. XVIII, IXb as a parallel for almost any of the forms in Figures 3.5.3 and 3.5.4.

2306x: Possibly Laming Macadam 1955 II, pl. XXXII.2a [2003], Napatan.

3.5.4 Bell jars

The angle overrides the type of rim (plain or beaded).

2698x: Nu.13 (23, 397-362 BC) fig. 171, 17-3-575.

3218x: Ku.T1 (A, 860-840 BC) fig. 1b, 19-3-358, red ware; Mohamed Ahmed 1992, fig. 27 III A8b mid 6th to late 5th centuries BC.

3.5.5 Bell jars, continued

3199x: Nu.61 (23, 397-362 BC) fig. 180, 18-2-358, red ware.

3232x: Bar.7 (31? 275-263 BC), fig. 132, 16-2-354; Barkal pottery Type VIII.3.

+3793x: Laming Macadam 1955 II, pl. XXXIII.4 [2089], Meroitic.

3.5.6 Deep open-mouthed jars with vertical or everted beaded rims

3493x: for an approximate parallel: Boulet 2017, fig. 3.f (25th Dynasty).



Plate 3.5.1. Examples of wheel-made jars.

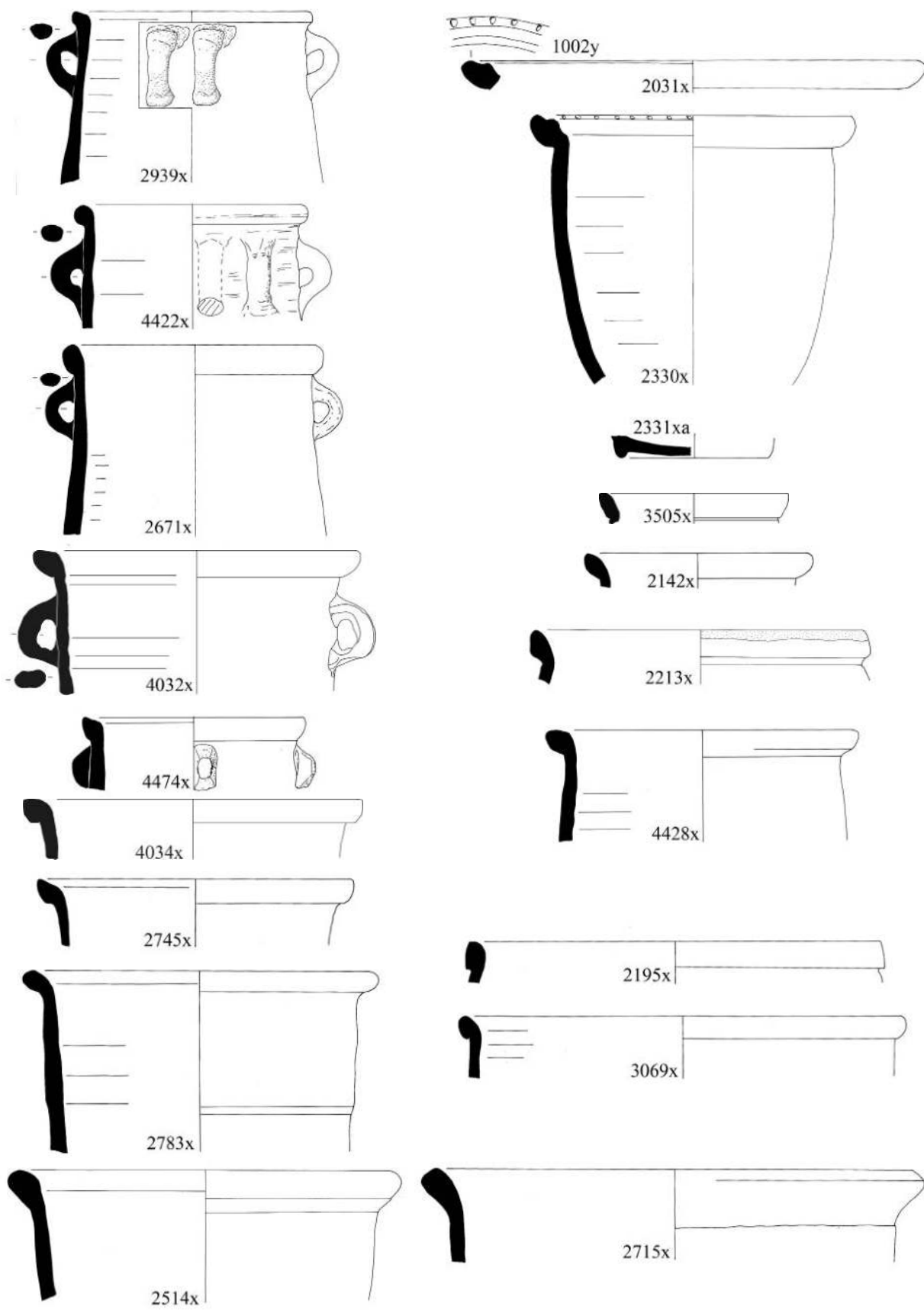

Figure 3.5.1. Deep jars with beaded rims, occasionally(?) with handles (scale 1:4).

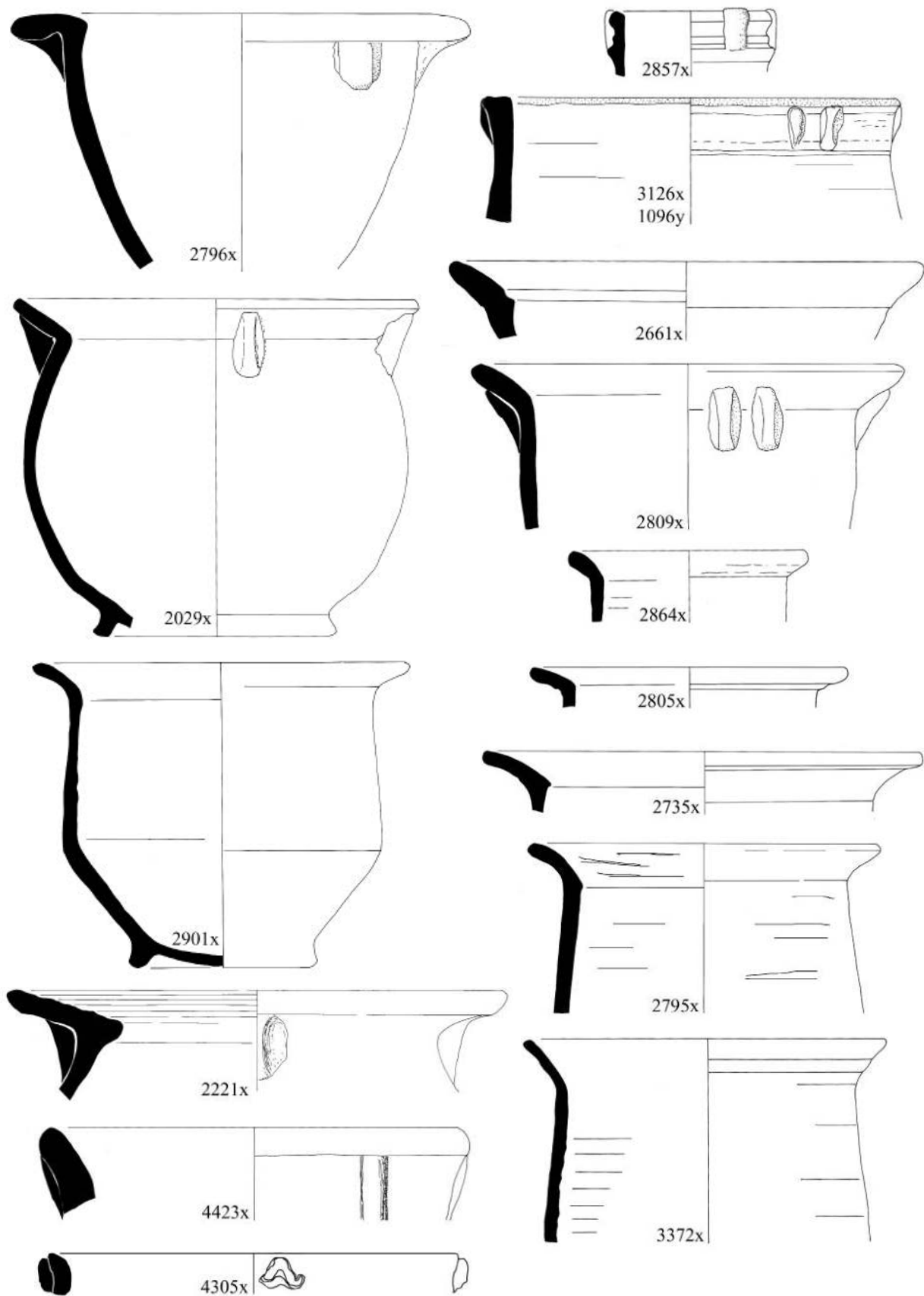

Figure 3.5.2. Butressed, ledge rim basins; some similar rim forms without the buttress (scale 1:4).

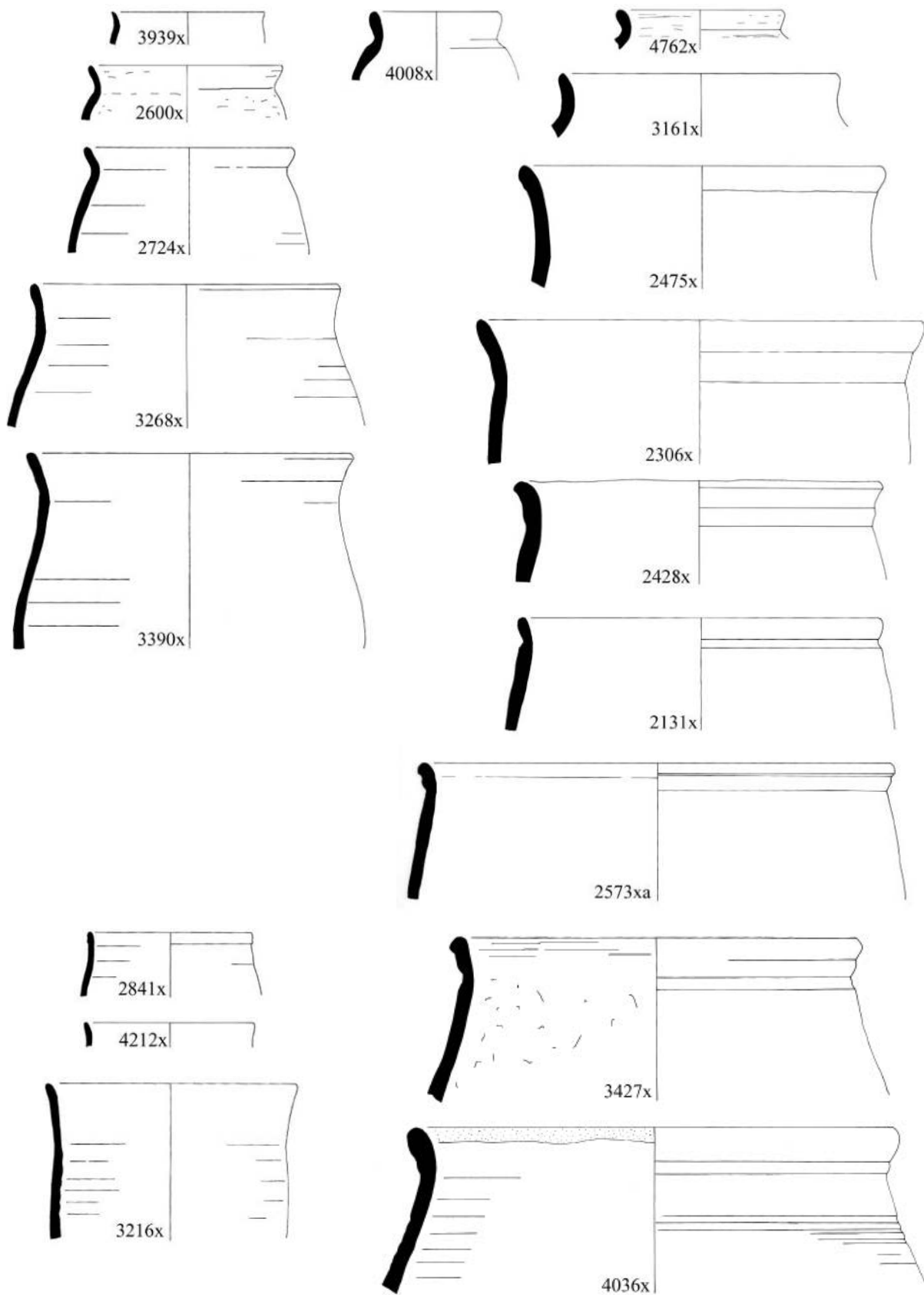

Figure 3.5.3. Jars with 'S'-shaped profile (scale 1:4).

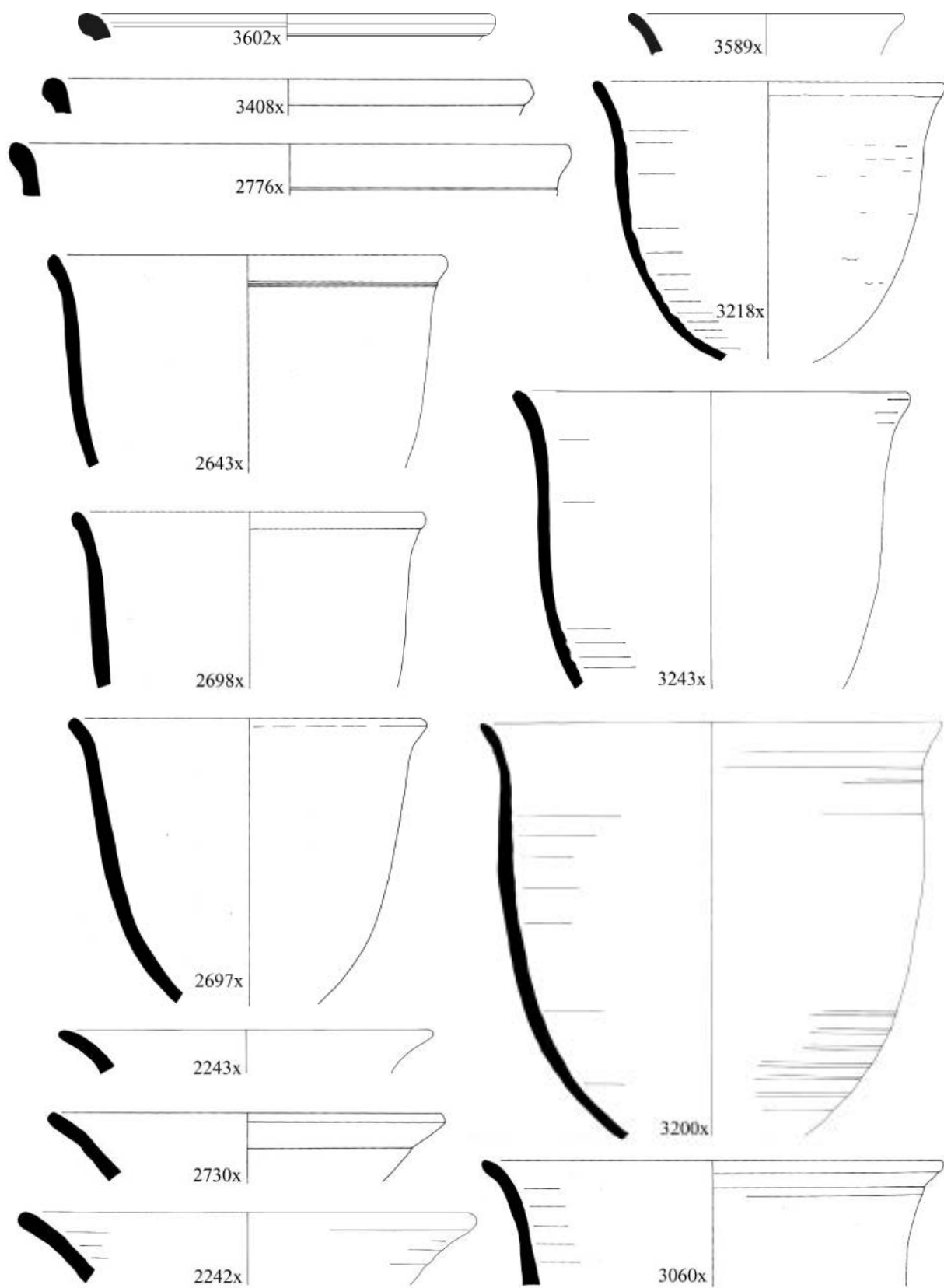

Figure 3.5.4. Bell jars (scale 1:4).

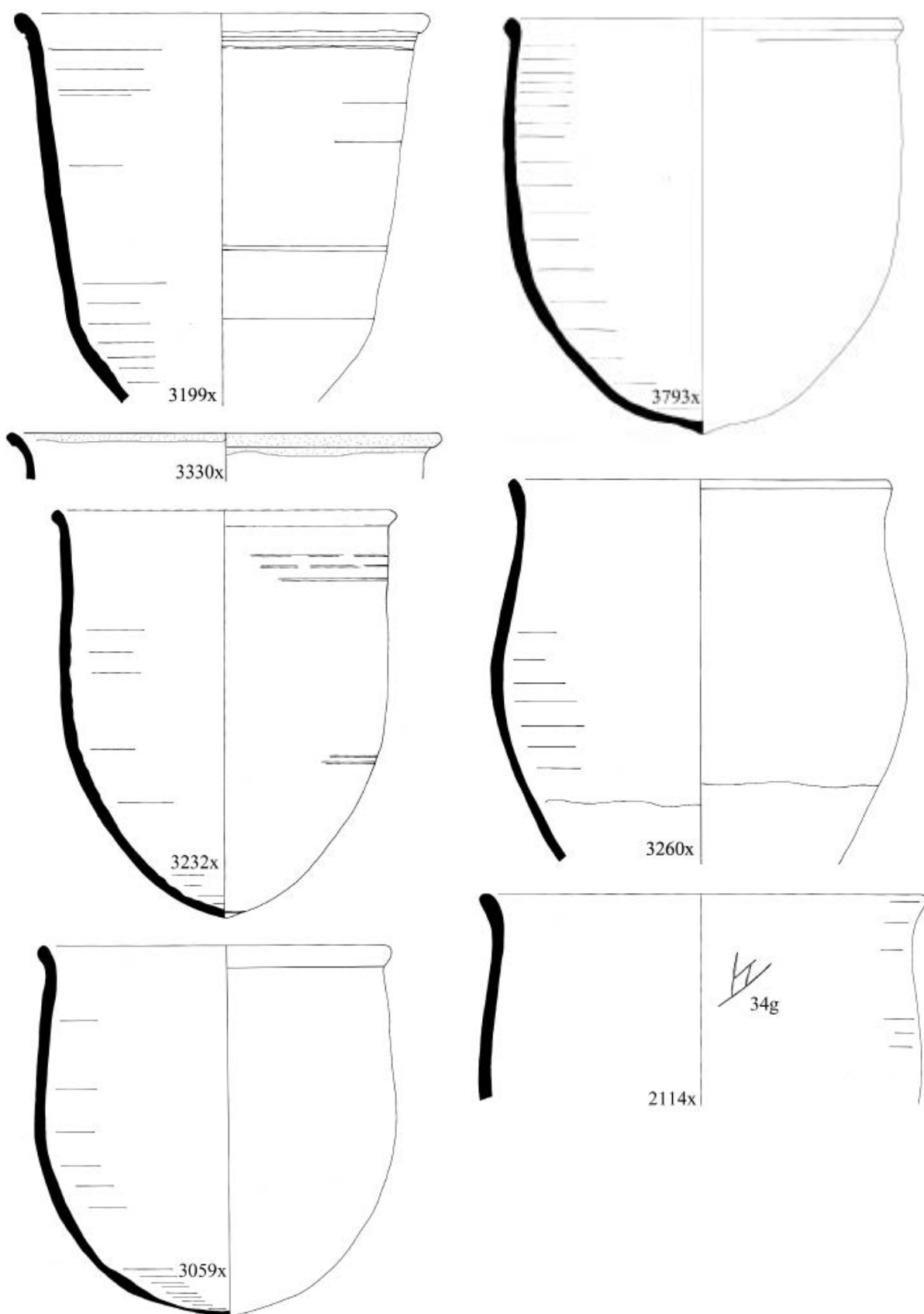

Figure 3.5.5. Bell jars (scale 1:4).

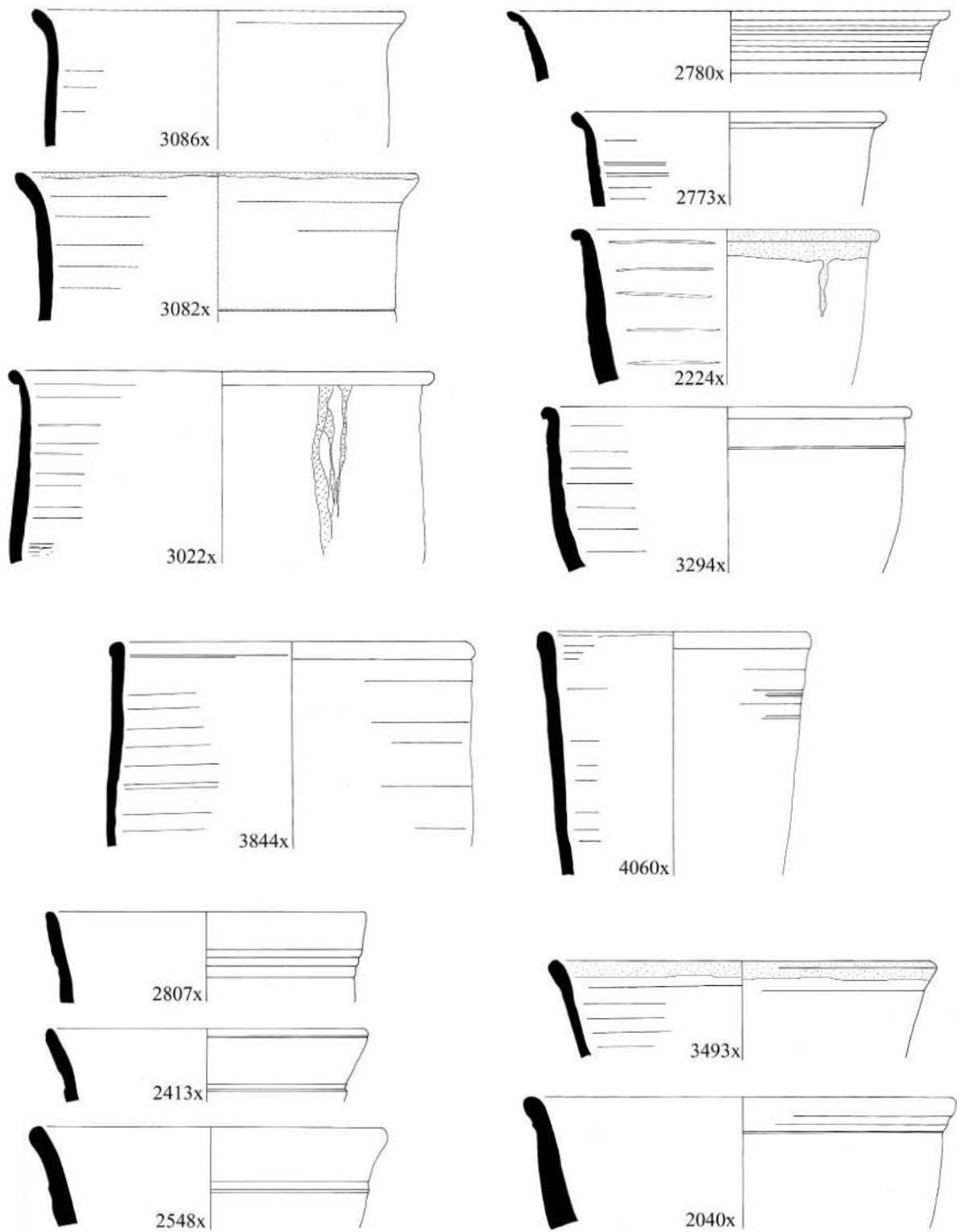

Figure 3.5.6. Deep bowls with everted, beaded rims (scale 1:4).

TABLE 3.5. MISCELLANEOUS OPEN-MOUTHED JARS.

Fig. no.	Type	Provenance	Fabric	Dec.	Surface treatment	Dia.	%	Man.	Comments
3.5.1	2031	(AB6)10	71 UF	1002		60	5	WM	
3.5.1	2142	(BC3)3 (BD2)63 (BE2)1,32 (BF1)61 (BF2)37 (BF3)8 (CE4)1 (FT3)15 (TG5)44	25 69 92 94	1017	822CR 822W 832W	13-31	84	WM	
3.5.1	2195	(AC5)45 (BD2)71 (BF3)8	65 67 92			16-30	22	WM	
3.5.1	2213	(BE3)55	61			24	16	WM	
3.5.1	2330	(BE2)110	67	1002	825EW	23	41	WM	
3.5.1	2331A	(BE2)110	67		825EW	11	25	WM	
3.5.1	2514	(BD2)26,71 (BE1)44,63 (BE2)38,158	67 69 94		820IP 820IR 822R 822Y	16-48	69	WM	
3.5.1	2671	(AB4)10	67			18	32	WM	
3.5.1	2715	(BC4)1 (BE1)18,87 (TG5)1	67 69 94		802 820IR 822R	21-38	38	WM	
3.5.1	2745	(AD5)268 (BF1)28	67 92		825EW	16-23	20	HM WM	
3.5.1	2783	(AB4)23 (BD2)24	67 94			26-29	43	WM	
3.5.1	2939	(AB4)31 (CF4)30 (JD2)43 (TG5)1	67 94		822CR	17-21	40	HM WM	
3.5.1	3069	(AD5)1	94			32	6	WM	
3.5.1	3505	(HA2)79 gr. 188	69			10	12	WM	
3.5.1	4032	(TG5)73	67			24	71	WM	
3.5.1	4034	(TG5)73	67			25	8	WM	
3.5.1	4422	(TG5)6	92			16	25	WM	
3.5.1	4428	(TG5)0,5/4	65 67		822R	22-33	32	WM	
3.5.1	4474	(CE4)9	56	boss		16	6	WM	
3.5.2	+2029	(AB4)23 (AC5)12 (AD5)161 (BC2)1 (BC3)1,2 (BC4)1,2 (BD2)23,26,27,28, 29,45,47,50,68,70,71. 100 (BD3)9,16,33 (BD4)17 (BE1)0 (BE2)66 (BE3)78 (BF1)53,56 (BF2)1,16,22,31,37, 47,49A-B (BF3)8,9,50,52,58 (CE5)1 (TG5)109	65 67 69 80 92 94 95 97	flange support not always present	H820ER H822R 820IR 822BR 822CR 822R 822Y 825ER 825EIR	(12-13) 17-35	873	HM WM	
3.5.2	2221	(BE4)16 (BF1)56	11 67		820IR	28-37	36	WM	
3.5.2	2661	(AB4)7	92		800I	35	7	WM	
3.5.2	2735	(BF1)6,45,53	92 94		820IR 820EW RBRI	23-37	34	WM	
3.5.2	2795	(BD2)59	11		822R	26	9	WM	
3.5.2	2796	(BD2)59	67		822R	34	21	WM	
3.5.2	2805	(BC4)1 (BF2)8	69 92		825ER	23-25	15	WM	
3.5.2	2809	(BD2)29 (BD3)8	92 94		825EIR	30-32	29	WM	
3.5.2	2857	(BD2)82	92			11	17	WM	
3.5.2	2864	(AD5)87 (BD2)24 (BD3)32 (CF4)7	65 80 92 130			17-33	57	HM WM	
3.5.2	2901	(BD2)32	92		H822R	29	31	WM	
3.5.2	3126	(ZH5)45	80	1096	820ER	25	12	HM	
3.5.2	3372	(AC5)39	94			27	2	WM	
3.5.2	4305	(CF3)22	92			19	9	HM	
3.5.2	4423	(TG5)6	67	buttress under rim		30	6	HM	

Fig. no.	Type	Provenance	Fabric	Dec.	Surface treatment	Dia.	%	Man.	Comments
3.5.3	2131	(BE1)44 (BE2)50 (BE3)9,55 (BE4)29 (BF1)28 (TG5)73	1 67 69 75 94			15-36	235	HM WM	
3.5.3	2306	(AB4)11,14,23 (AB5)218 (AB6)7 (AC5)8 (BD2)26 (BE2)67 (BE3)16,130 (BF1)13,56 (FQ4)35 (FR3)28	67 69 71 80 92 94		825IR RBR TOP	10-37 (50)	180	HM WM SW	
3.5.3	2428	(BE3)27	67		822R	27	16	WM	
3.5.3	2475	(AB4)7,10,11,23 (AD5)1,56,67,132 (BD4)16 (BE2)48,158 (BE3)16 (BF1)16,53 (BF2)31,32 (CE4)14 (CF3)5 (FO6)59 (FQ3)58 (FT3)6 (JD2)1 (TG5)4	1 9 67 69 80 89 71 92 93 94 110 112		820ER 822O 822R 822W 825ER 825EW 910 RBRI RBRIE	15-37	293	HM WM	
3.5.3	2573a	(TG5)87	94		825EIR	24	11	WM	
3.5.3	2600	(AB5)58 (FR3)14 (FT3)1	46 69 110		822R RBRIE	7-14	44	HM WM	
3.5.3	2724	(AC5)53,82,84 (AD5)154,160 (BE1)80 (CE4)1 (FR3)14 (TG5)5/4	69 89 92 94 94C 110		825ER 910 RBRIE	14-23	52	HM WM	
3.5.3	2841	(AC6)34 (AD6)5	92 92F		825EBL	12-15	45	WM	
3.5.3	3161	(BE3)22 (BF3)50 (FS3)1	67 92 93		830EW	17-20	26	HM WM	
3.5.3	3216	(AD5)28,34 112,117 (FQ3)65	65 90 92 93 94		822R	15-23	40	WM	
3.5.3	3268	(AC5)37 (AD5)217,242 (TG5)5/4	67 80 92 110		825EICR 825EIP	12-22	50	HM WM	
3.5.3	3390	(AC5)45 (AD5)257,311 (BF2)31	65 90C 110		825EIP 910 RBRIE	19-25	45	HM WM	
3.5.3	3427	(BF1)25 (TG5)1	92			28-29	17	HM WM	
3.5.3	3939	(FQ4)37	102		825EW	11	13	WM	
3.5.3	4008	(CE4)37 (CF4)88 (TG5)73	67 92 94			9-13	71	HM WM	
3.5.3	4036	(TG5)73	92		820ER	35	18	WM	
3.5.3	4212	(TG5)1,103	92		822ER	16	28	WM	
3.5.3	4762	(FP7)184	11		825EIBR	11	12	WM	
3.5.4	2242	(AB4)5,11,14 (AB5)20 (AC5)12 (AD5)1,168,262 (BC4)1 (BD2)28,71,89,97 (BD3)16 (BE2)71 (BE3)27,56,78 (BF1)44 (FQ/R4)2 (FQ4)33 (FS3)6 (TG5)29	2 67 69 80 83 92 94		820ER 820IW 822W 825IR 825ER 825IERO	18-33	229	HM WM	
3.5.4	2243	(AB5)20 (AD5)1 (BD2)28 (BD4)19 (BE3)56,78 (BE4)82 (CF4)113 (FO6)90 (FP7)130 (TG5)6	65 92 94 94L 110		822R RBRI	17-32	100	HM WM	
3.5.4	2643	(AB4)14 (AC5)24,34 (AD5)28,69,97,161A (BD2)28,94 (BF3)8 (ZH5)53	65 67 69 92		825EBL RBRIE	19-34	106	HM WM	

Fig. no.	Type	Provenance	Fabric	Dec.	Surface treatment	Dia.	%	Man.	Comments
3.5.4	2697	(AB4)11 (AC5)34 (AD5)4,7,32,34 (HA2)72 gr. 71 (FQ4)27,63,113 (FS3)6	67 67F 71 92 94	1159	820IW 825IR 825EW RBRIE	20-38	130	HM WM	(FQ4) from brick
3.5.4	2698	(AB4)11,23,32,33 (AB5)205 (AD5)113,161A (CF4)1 (FQ4)7	65 67 92 94 110		825IR	15-27	114	HM WM	
3.5.4	2730	(BE2)145 (TG5)18,91	25 92			28-30	24	HM WM	
3.5.4	2776	(AD5)112 (BD3)9 (FQ3)7	92 94 132			21-40	22	WM	
3.5.4	3060	(AC5)24 (AD5)28,34,54	67 92 93 94	871	825ER	23-33	73	WM	
3.5.4	3200	(AD5)20	80			32	25	WM	
3.5.4	3218	(AC5)37 (AD5)34 (FQ4)6 (FR4)2 (TG5)5/4	92 94		825EW RBRI	15-26	64	WM	
3.5.4	3243	(AD5)28,54,57,112 (AC5)37 (FQ4)7,80 (FR4)1	92 92F 93 94 94F		825EBL RBRIE	16-30	159	WM	
3.5.4	3408	(AD5)0 (TG5)74	92		820EW	30-34	7	HM WM	
3.5.4	3589	(FO6)172 (TG5)18,70	105			10-20	18	HM WM	
3.5.4	3602	(TG5)22	-			30	-	WM	
3.5.5	2114	(AC5)34 (AD5)167 (BF1)28 (CE5)1 (FS3)11 (TG5)5/4 98/1/4.47	74 90 94 110	34g	825EIW	19-32	53	HM WM	
3.5.5	3059	(AC5)23 (AD5)67,139 (CF5)1 (FR3)0	65 92 93 94		825EW 825EIW RBRIE	24-29	27	WM	
3.5.5	3199	(AD5)20	92		825EIW	29	36	WM	
3.5.5	3232	(AC5)37,38 (AD5)28,41,134,160, 198,269 (AD6)13 (FS3)13	17/67 65 92 94			24-27	75 + B 900	WM	
3.5.5	3260	(AC5)38 (AD5)34,67,112,136	90 92 93 94		825EBL 825IP RBRIE	17-27	113	WM	
3.5.5	3330	(AD5)113	67		825ER	31	4	WM	
3.5.5	+3793	(AC5)73	94		825ECR	25	130	WM	
3.5.6	2040	(BE2)1 (BE3)56 (BE4)37	66 69 92			19-29	18	HM WM	
3.5.6	2224	(BE3)65,73	69 92		820IR 825EP	20-27	6	HM	
3.5.6	2413	(AB4)23 (BE3)1	94		822R	22-24	31	WM	
3.5.6	2548	(BE2)103 (TG5)85	56 94	850	H820IR	24-34	19	WM	
3.5.6	2773	(AB5)59 (BC2)2 (BD2)81	69 80 92			12-24	25	WM	
3.5.6	2780	(BD3)16 (FR3)12	93 94		RBRIE	15-31	14	WM	
3.5.6	2807	(AD5)7 (BC3)3 (TG5)85	69 92 94		825IR 822R	18-25	56	HM WM	
3.5.6	3022	(AC5)17	65	brown dribble		29	15	WM	dribble from content?
3.5.6	3082	(AC5)165 (AD5)1,207 (AD6)13 (ZH5)60	67F 92 92F 94		825EIBL RBRIE	16-28	132	WM	
3.5.6	3086	(AC5)23 (AD5)112 (CF4)30 (FQ4)80 (JD2)43 gr. 40 (TG5)87 (ZH5)60	67 81 92 94		RBRI	12-24	112	HM WM	

Fig. no.	Type	Provenance	Fabric	Dec.	Surface treatment	Dia.	%	Man.	Comments
3.5.6	3294	(AC5)57	67			25	10	WM	
3.5.6	3493	(AD5)198	92		RBR	26	4	WM	
3.5.6	3844	(AC5)127	92F	855E		24	17	WM	
3.5.6	4060	(BF2)31 (TG5)4,73	67 80 94			18-30	45	WM	

3.6. Decorated wares, cups, open bowls and basins, handmade and wheel-made

Decorated jars and bowls (mostly Meroitic) and Kerma and Neolithic wares from the cemetery, followed by bowls, both coarse and fineware; miscellaneous open cups or beakers; flanged bowls and basins.

3.6.1 Incised decorated Meroitic wares; also Neolithic and Kerma period forms from Site R18 and occasional finds from the town site

2653x, 2653xa: Bar.8 (32.I, 263-248 BC) 16-2-383, 'x-ware' (decoration only, not form). See also Vila 1982, fig. 79.2 (Meroitic), although the angle is everted and we do not know what the base would have been like.

2959x: The decoration, an impressed register of dots around the rim and the slip painted triangles, is replicated at Gemai, albeit on a different form, a deep open jar with a flat base (Bates and Dunham 1927, pl. LXI fig. 3 E81).

3001x: Unusual form for a crocodile (or monitor lizard?) appliqué. Unique at Kawa, and no direct parallels have been found. For other examples of animal appliqués, see 3.8.14, 3.9.7, 3.11.10 and 4.4.

+4335x, +4336x: cf. Ku.4 (5), 690-664 BC, but rightly thought to be intrusive (MFA acc. no. 20.4791, 743-712 BC); both date ranges are incorrect. Bashir and David 2015, fig. 2, B34-244; also at Gabati (Rose 1998, fig. 6.19) 1st century AD; at Faras (Griffith 1924, pl. XLII.5 and XLIII, passim).

4335x: Cf. Beg.W.214 (50-55? AD 25-115) fig. J1, 23-1-68, form only, without decoration. Jar <7502> at Gabati has a very similar form, but the decoration pattern is different, although also comb-impressed. It has been dated to *circa* the last three centuries BC (Rose 1998, 265, 267, fig. 6.22)

+4336x: Similar to Beg.N.21 (40, 116-99 BC) fig. 55, 22-2-124. Also Bates and Dunham 1927, pl. XXIV fig. 2B; Vila 1982, fig. 69.2, Meroitic. The join between the shoulder and neck is weak, and not only was the rim broken away at Site R18, but we can see breaks on similar vessels, such as in the Gemmai photo (Bates and Dunham, above).

+4477x and +4478x: These two *Kerma Classique* beakers were both found among the domestic occupation layers of Room A in Building C25 in Area C, probably early Meroitic in date, and were most likely 'recycled' by Meroitic tomb robbers /antiquarians. 4478x had lost its original rim, but the broken edge had been smoothed, so that the beaker was still functional. Whether this was done in the Kerma period or later cannot be determined, although it is more likely that the damage was later in date, rather than a repaired beaker was placed in the grave. Two further instances of *Kerma Classique* sherds were found in Room B of Building C25 and in Room A in Building C31. For a similar occurrence on Sai, see Francigny 2014, 801, pl. 6.

4545x: Edwards 2014, 52-53, fig. 1, probably last centuries BC. Similar decoration in particular.

4553x: Possibly also a Kerma period vessel, from a tomb robbed in antiquity.

BU2.16: Residual *Kerma Ancien* rim, occurs also with impressed decoration D25.9, a pattern of dotted rhombs (cf. Welsby Sjöström 2001, fig. 5.60).

3.6.2 Fineware bowls and cups

There may be some overlap between these rims and those of the coarseware beakers in 3.10.1-3.10.3.

3143x: Mohamed Ahmed 1992, fig. 20 ID11 7th century BC.

3533x: Mohamed Ahmed 1992, fig. 19 I D61 mid 6th to early 5th centuries BC.

3535x: Rilly *et al.* 2020, 89, fig. 32. Meroitic.

3621x: David 2012, fig. 1a, 3rd to early 4th centuries AD. Note that a cup similar to (*ibid*) fig. 3.f was also found in the cemetery during the survey in the 1990s, in association with a narrow-necked jar, albeit a different form to those referenced by David in fig. 2 (Welsby Sjöström 2001, figs 5.15, J19.1 and 5.51, C1.1)

4764x: 1263y, decoration in Török 1997 II, fig. 90.284.15, early to mid Meroitic period.

+4781x: Note the similarity of the form to the RBRIE beakers in 3.7.6, but in this instance with a red-slipped exterior and sparse pale brown slip/burnish on the interior. Napatan in date. Vincentelli 2006, fig. 2.82 532, 8th to 7th centuries BC. Also Napatan by association with the other vessels in the same grave group, grave (GD3)11.

+4785x: Meroitic. Garcia Guinea and Teixidor 1965, fig. 15.2 (Nellulah, tomb 10), form similar but not identical, although the flower decoration on the base is very similar; Beg.W.145 (45-55? 43 BC - AD 115) fig. C.24, 22-2-316 (form only). Note also similarity of both form and wall decoration to a Meroitic bronze bowl from Karanog (Woolley and Randall-MacIver 1910 IV, pl. 31, 7132.G394).

+4788x: Garcia Guinea and Teixidor 1965, pls V b (Nellulah, tomb 3) and XIII b (tomb 8), decoration very similar but not identical; Török 1997 II, fig. 90.284-8, a coarser form, but decoration the same, early to middle Meroitic period; Beg.W.125 (55-65? AD 93-246) fig. G21, 22-2-169. For a slightly different form, but with the same decoration (1273y), Laming Macadam 1955 II, pl. LXXXIV.c [0815] and pls XXXIII.7 and CV.a [2164], Meroitic date, from the 1935-6 excavations at Kawa.

4795x: Made of Fabric 132, not a kaolin based fabric, and most likely the white wash (or very abraded slip) will have been used to give the vessel the look of a fineware cup.

4832x: MFA acc. n. 20.4483, found in the Barkal temple of Amun, chapel B.504, 750-270 BC, i.e. Napatan.

3.6.3 Thin-walled bowls with a short section, miscellaneous open bowls and dishes

2292x: Beg.N.5 (50, AD 25-41) fig. 84, 21-12-33b.

3094x: Approximately like Nu.61 (23, 397-362 BC) fig. 180, 18-2-366.

3134x: Nu.12 (21, 418-398 BC) fig. 163, 17-1-166.

3292x: Nu.33 (21, 418-398 BC) fig. 167, 18-3-320.

4057x: Nu.5 (12, 553-538 BC) fig. 106, 16-11-64.

4273x: Meroitic bowl, 1st century BC?

3.6.4 Medium-sized beakers and plain deep bowls

2613x: Nowotnick 2018, fig. 3, 0970.

3.6.5 Carinated bowls

Note similarity to others in 3.10.6, placed there because their appearance in terms of fabric, manufacture and

surface finish closely resembles the offering dishes in that section.

2034x: Spence and Rose 2010, fig. 1.4, 18th Dynasty.

2053x: Mohamed Ahmed 1992 II, B6, early 7th century to the first half of the 5th century BC.

2059x: Beg.W.140 (50-55, AD 25-115) fig. F.20, 22-2-299.

2065x, 2065xc: Laming Macadam 1955 II, pl. XXXII.7 [2021], Napatan.

2065x: also bronze parallel Bar.8 (32.I, 263-248 BC) fig. 33, 16-4-80. Note also similarity of this form to the contemporary Greek Archaic cup-*skyphos*, but without the vertical handles and most likely not ring-footed (Lynch 2011, fig. 58 no. 51, pp. 209-10).

2065xb: Spence and Rose 2010, fig. 1.6, 18th Dynasty.

2067xa: Nu.44 (23, 397-362 BC) fig. 178, 17-4-32.

2100x: cf. Williams 1990, fig. 26.a and pl. 7.d, cemetery VC near Qustul, grave VC46, Napatan.

2140x: Aston 1999, pl. 41.1321, Libyan period, 1000/950-750/700 BC; very similar to bronze form Ku.72 (4, 701-690 BC) fig. 35e, 19-3-1552.

3340x: Lynch 2011, 210, fig. 59 no. 52; also similar to the cup-*skyphos*.

3368: Nu.1 (5, 690-664 BC) fig. 4, 16-1,2-17.

3430x: cf. Boulet 2018, fig. 1.o, 25th Dynasty.

+4540x: While in the context of Kawa, this form is most likely Meroitic, it does bear resemblance to a Greek form, a coarseware bowl (Lynch 2011, 281 fig. 143, no. 183, 525-480 BC).

3.6.6 Cups with long neck and bulbous base; miscellaneous bowls with groove by rim

For the cups, see also Dunham 1963, 337, fig. A12; Griffith 1923, pl. 18.12n; Laming Macadam 1955, pl. 32.14a and 14b and Shinnie and Bradley 1980, fig. 36.89-90.

+2597x: Laming Macadam 1955 II, pl. XXXII.14b [2020], Napatan; Beg.W.695 (4-8? 701-623 BC) fig. A.12, 23-3-525. Nowotnick 2018, 212, fig. 7, left-hand vessel; Griffith 1923, pl. XVIII.XIII n

2766x: With wider diameter, Beg.W.377 (50-60? AD 25-184) fig. F37, 23-2-195.

2935x: Laming Macadam 1955 II, pl. XXXII.14a [2059], Napatan.

4062x: Mohamed Ahmed 1992, fig. 16 IA17, (7th to mid 6th centuries BC) albeit with a different rim, the overall shape and size of the vessels is similar.

4090x: Boulet 2018, fig. 2b, 25th Dynasty; Nowotnick 2018, 212, fig. 7, right hand vessel; Ruffieux 2007, pl. 2.10 [17-11], marl clay (Dokki Gel, Napatan); Nu.47 (16, 503-478 BC) fig. 130, 18-1-160.

3.6.7 (and 3.6.8) Open bowls with ribbing by rim

2644x: Meroitic.

2738x: Ruffieux 2007, pl. 3.22 [12 B-21], Nile clay. Napatan

2752x: Nu.34 (23, 397-362) fig. 174, 18-1-440, same vessel MFA acc. no. 20.4777, 404-396 BC. Note that the parallel has no slip, unlike what is usual with this type of bowl/beaker at Kawa.

+3085x: Nu.34 (23, 397-362 BC) fig. 174, 18-1-44c red ware.

3361x: Nu.31 (19, 453-423 BC) fig. 154, 18-3-336.

3.6.8 More open bowls with ribbing by rim

958x: Mohamed Ahmed 1992, fig. 20 I D12b (7th to mid 6th centuries BC, more common in the 6th).

2024x: Nu.31 (19, 453-423 BC) fig. 154, 18-3-336.

2606x: Vila 1980, fig. 152.1, type II-2.

2606xa: Beg.N.16 (53, AD 62-78) fig. 91, 21-3-583a.

2876x: Mohamed Ahmed 1992, fig. 28 III C4 mid 6th to late 5th centuries BC.

2903x: Laming Macadam 1955 II, pl. XXXII.6a [2072], Napatan.

2938x: Vila 1980, fig. 152.1. Napatan.

2970x: Vila 1980, fig. 28.10, type II-2. Napatan.

3301x: Nu.13 (23, 397-362 BC) fig. 172, 18-4-84, red ware.

3.6.9 Ribbed ware and bowls with flanges.

Note similarity to larger vessels in 4.2

2737x: Mohamed Ahmed 1992, fig. 21 I D13b mid 6th to early 5th centuries BC.

4264x: Mohamed Ahmed 1992, fig. 21 I D15b late 7th to mid 6th centuries BC.

3.6.10 Bowls with everted, decorated rims

Chiefly wheel-made. The majority were found in Area B and grid square (TG5). The ambiguity in dating that the parallels below offer, coupled with the stratigraphic locations of the contexts they were found in, suggests that a Napatan date can nevertheless be ascribed to the general style.

2055xc: Mohamed Ahmed 1992, II B3, early 7th to first half of the 5th centuries BC.

2593x: for rim decoration only, (1051y) cf. Robertson and Hill 2004, pl. VIIIb.2, c. 800-550 BC; Török 1997 II, fig. 114 297-36, probably pre-2nd century BC.

2736x and **4324x:** Bar.6 (44, 56-43 BC) fig. 66, 16-2-364, polished red ware.

4324x: Robertson and Hill 2004, pl. VIIa.6, c. 800-550 BC.

3.6.11 Bowls with ledge or beaded rims

Laming Macadam has published two Meroitic examples from Kawa that more or less fit the types here (1955 II, pl. XXXIII.8 [2119] and 10 [2097]). The pie-crust lugs on some of the types, also found on Napatan deep bowls (2664x, 4.6) may mean that these precede the Meroitic.

2463x: Nu.49 (18?, 458-453 BC) fig. 146, 18-1-92.

3252x: Beg.W.179 (55-65, AD 93-246) fig. E26, 22-2-403, with flat base; Beg.W.214 (50-55? AD 25-115) fig. F2, 23-1-67; Beg.W.126 (55-65? AD 93-246) fig. F.1, 22-2-186.

3498x: Klimaszewska-Drabot 2003, pl. 1a, proto-Kushite?

3.6.12 Bowls and basins with ledge rims

This form (with the ledge) is later – Meroitic. For the more delicate forms at the top of the page in particular see Bąkowska 2010, fig. 3.25-31 (dated to 1st-2nd centuries AD). **2111x, 3675x** and **4322x:** Török 1997 II, fig. 67 198-7,

10, 11; Beg.W.162 (45-55? 43 BC- AD 115) fig. C15, 23-1-48c.

3017x: Bąkowska 2010, fig. 4.41, though more rounded wall, 1st to 2nd centuries AD.

3675x: Beg.N.22 (49, AD 0-25) fig. 78, 22-1-136a; MFA acc. no. 20.4525, from Barkal, B504, 750-270 BC.

3678x: Meroitic.

+**4331x:** Beg.W27 (45-50? 43 BC- AD 41) fig. C18, 22-2-461; Beg.N.20 (39, 133-116 BC) fig. 50, 21-12-119 HRW; Rose 1998, 168, fig. 6.14, [7102], with a more delicate, downward sloping ledge, but unique at Gabati for having a ring base; thought to be earlier than similar bowls with a flat base. Griffith 1924, pl. 27. LXIIIc, same rim decoration, but with a flat base; Bashir and David 2011, fig. 6.1, 3rd century AD (with a flat base).

4407x: Nu.9 (11, 568-553 BC) fig. 91, 16-12-126, red ware; note however a similar form from Barkal (MFA acc. no. 20.4605, from B500, room 501, VI 'brick room', dated to the 18th-19th Dynasties; Orzechowska 2003, pl. 3d, Meroitic?.

4446x: Meroitic fineware. Beg.N.6 (46, 26-20 BC) fig. 73, 21-3-437; Beg.N.16 (53, AD 62-78) fig. 91, 21-3-583d; Beg.N.17 (54, AD 78-93) fig. 94, 21-3-548.

4768x: Bar.11 (27, 322-315 BC) fig. 3, 16-2-410, but with decoration on rim, so more likely Medieval?

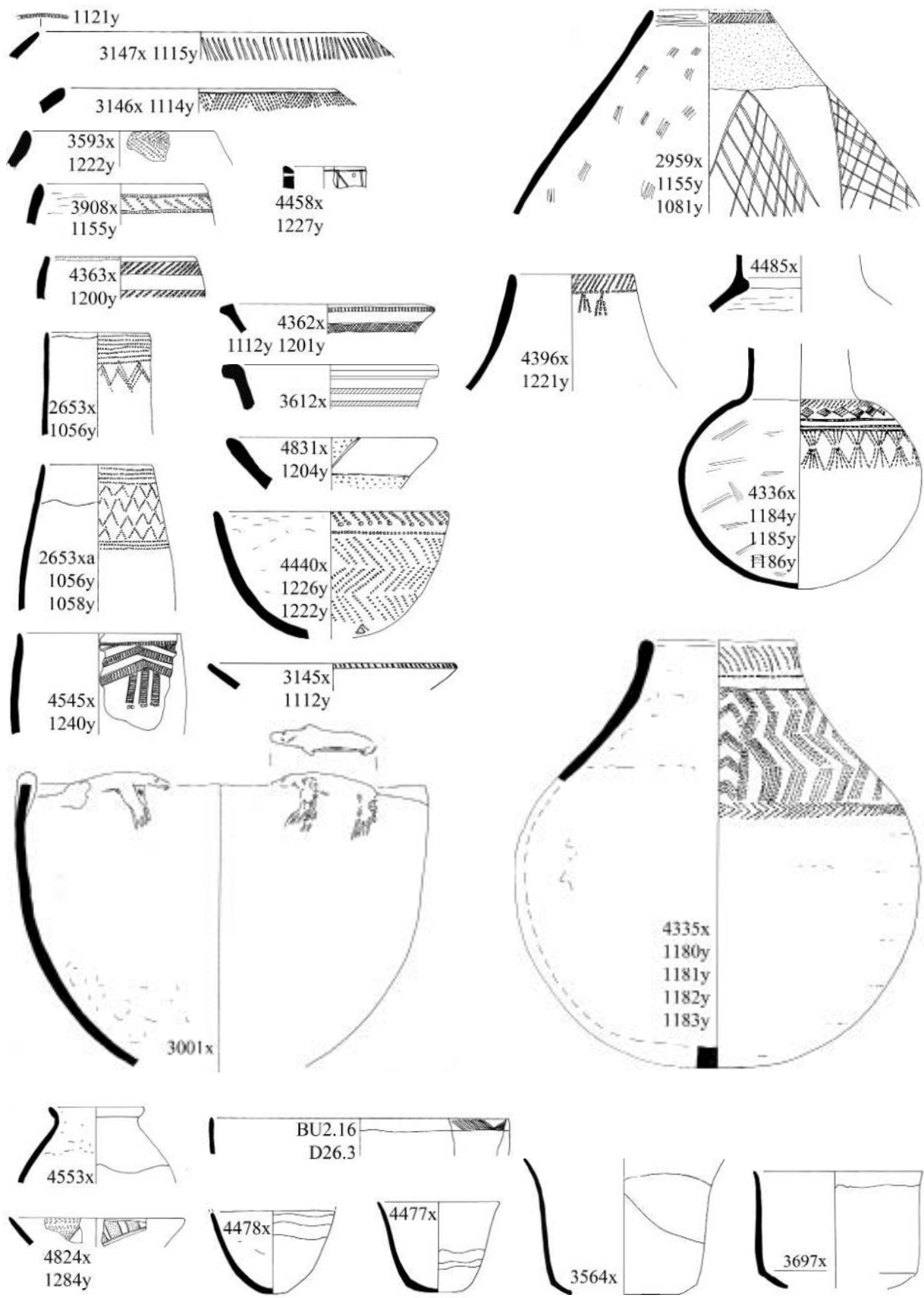

Figure 3.6.1. Decorated wares, especially Meroitic; also miscellaneous Neolithic and Kerma period forms (scale 1:4).

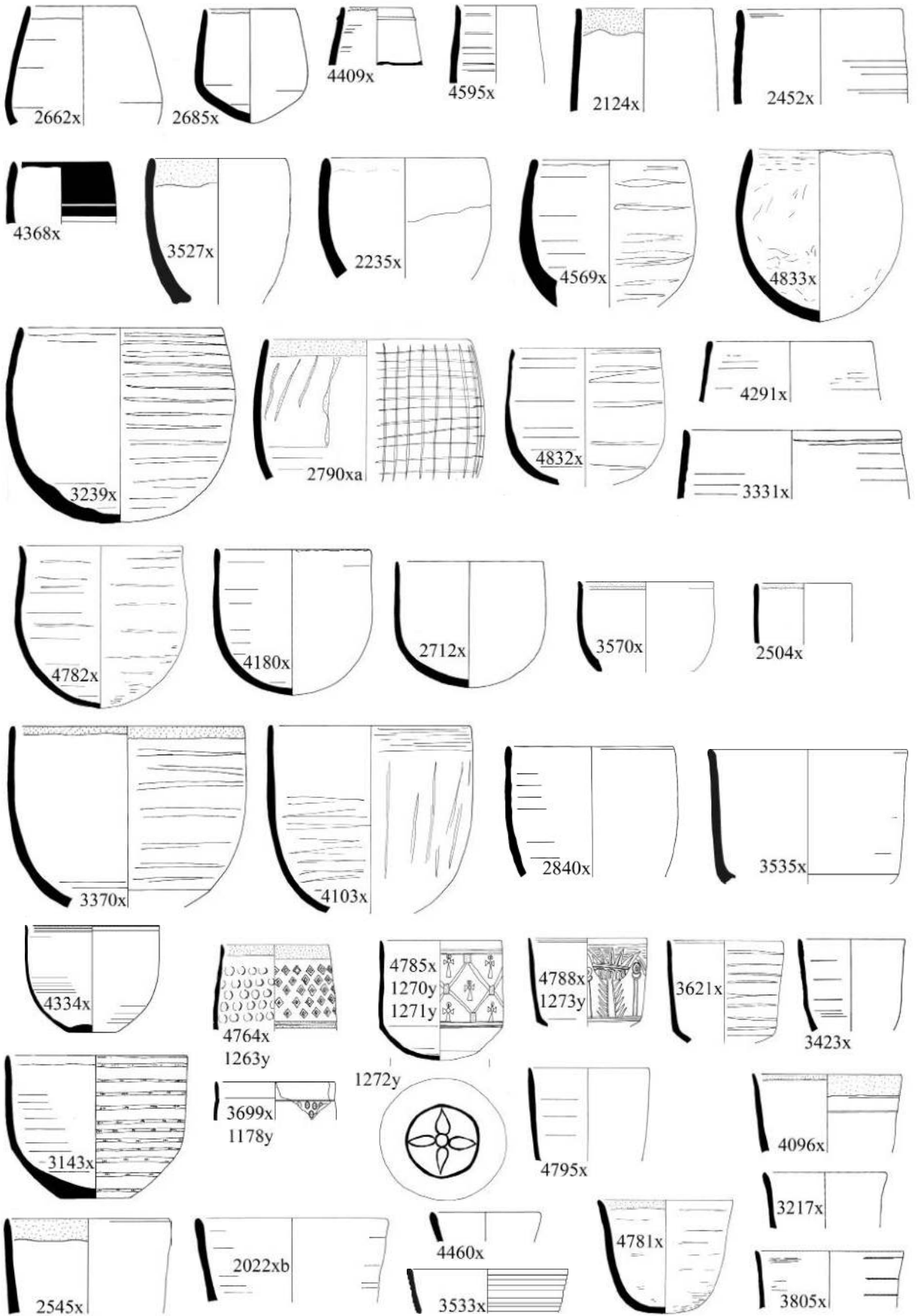

Figure 3.6.2. Bowls and cups of Napatan and Meroitic date (scale 1:4).



Figure 3.6.3. Wide-mouthed bowls and dishes (scale 1:4).

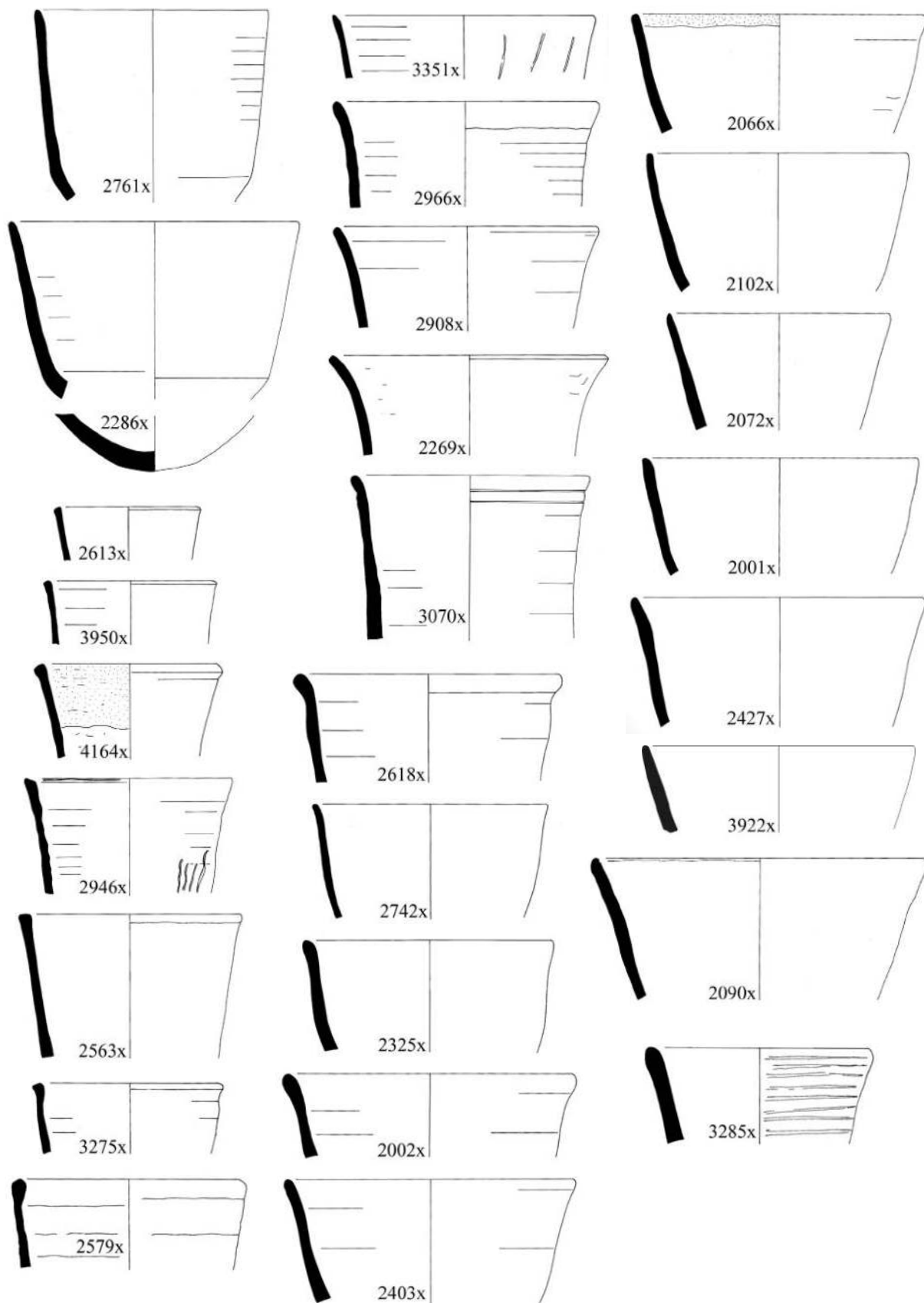

Figure 3.6.4. Beakers and deep, plain-rimmed bowls (scale 1:4).

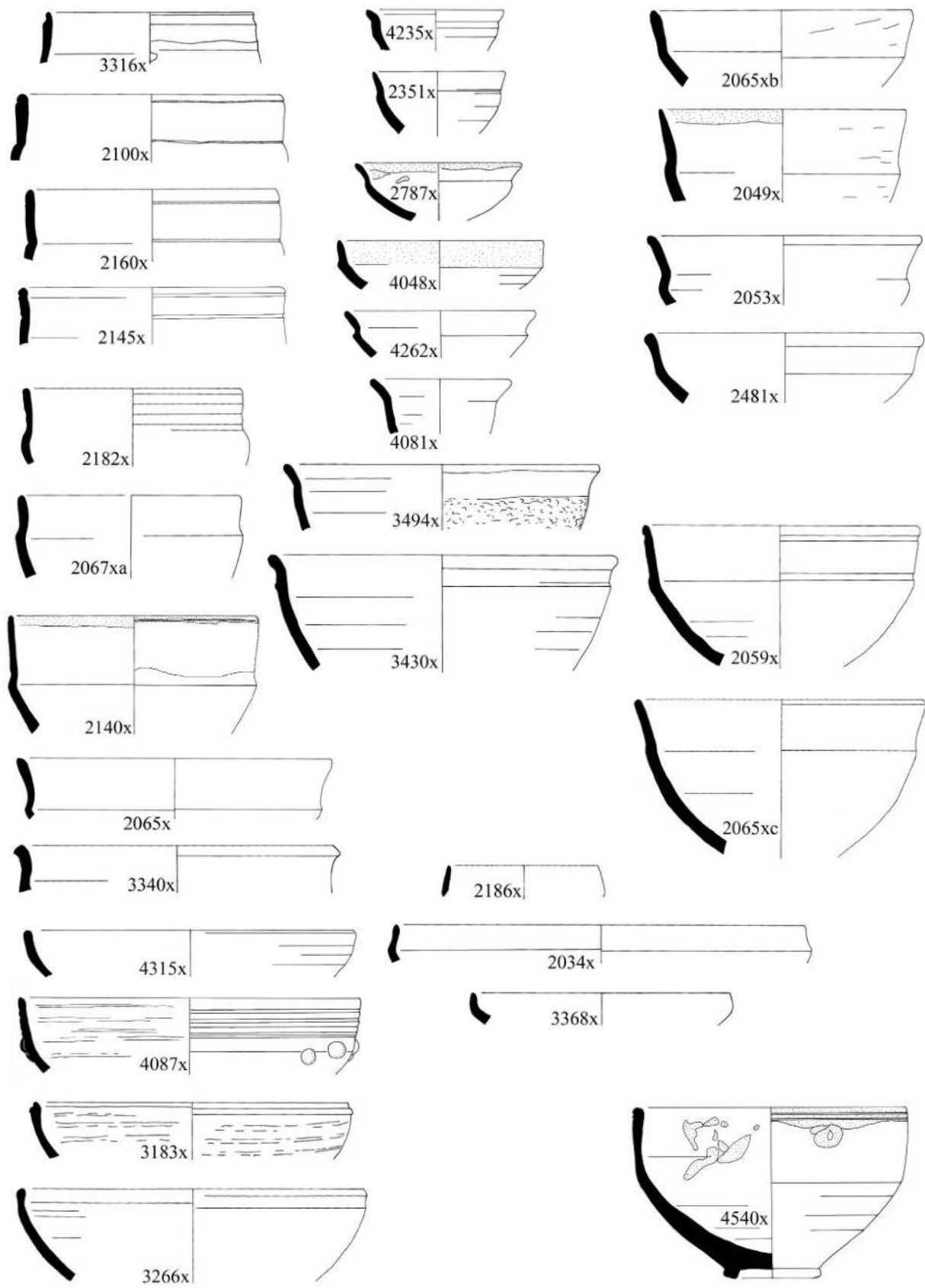

Figure 3.6.5. Carinated bowls (scale 1:4).

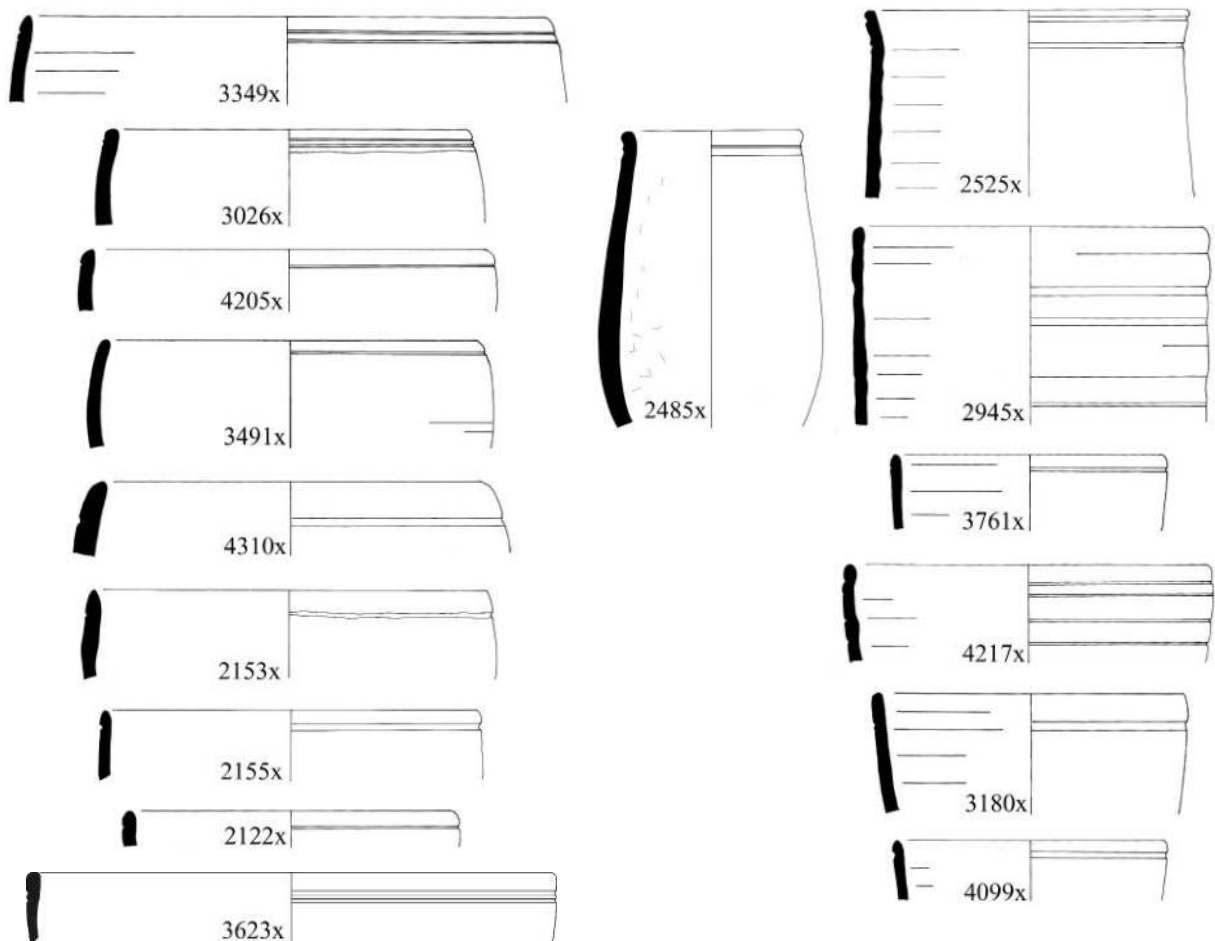
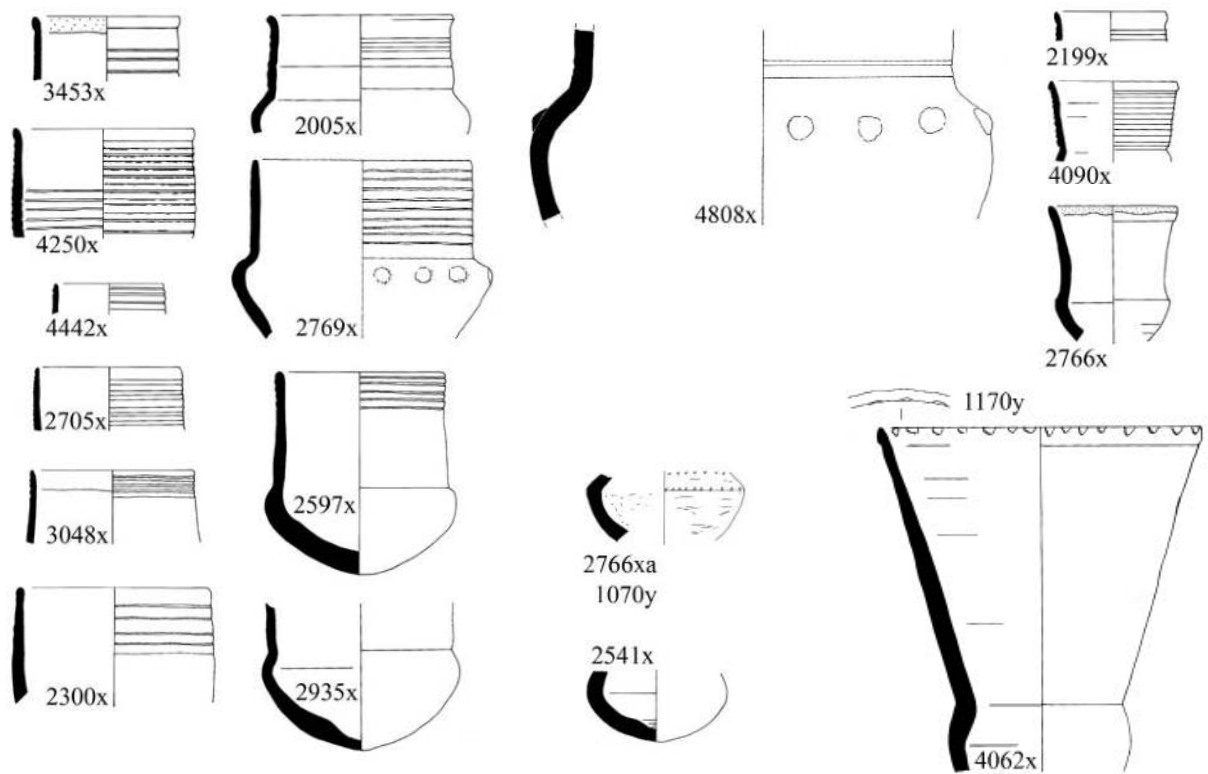

Figure 3.6.6. Cups and miscellaneous bowls with a groove by the rim (scale 1:4).

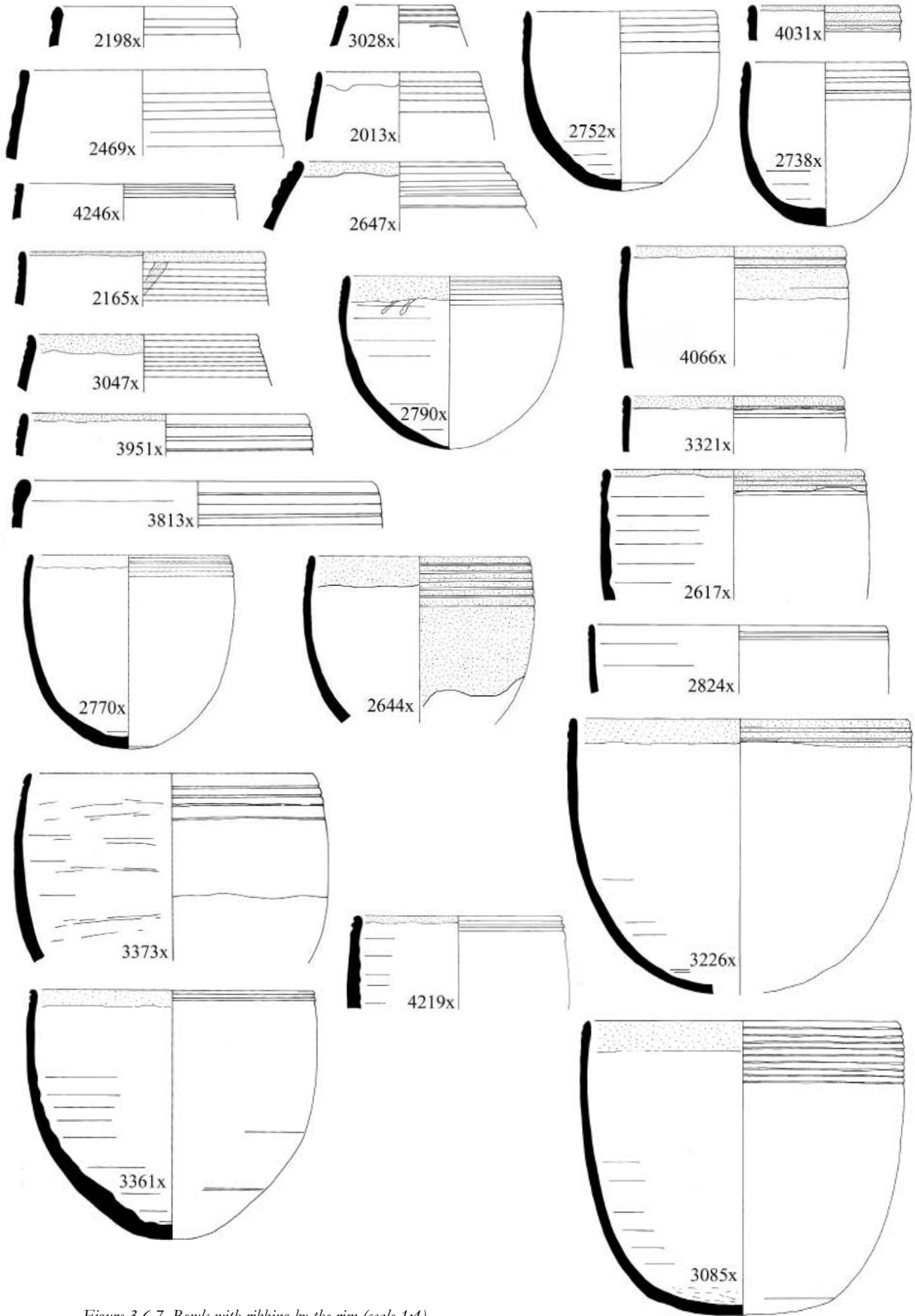

Figure 3.6.7. Bowls with ribbing by the rim (scale 1:4).

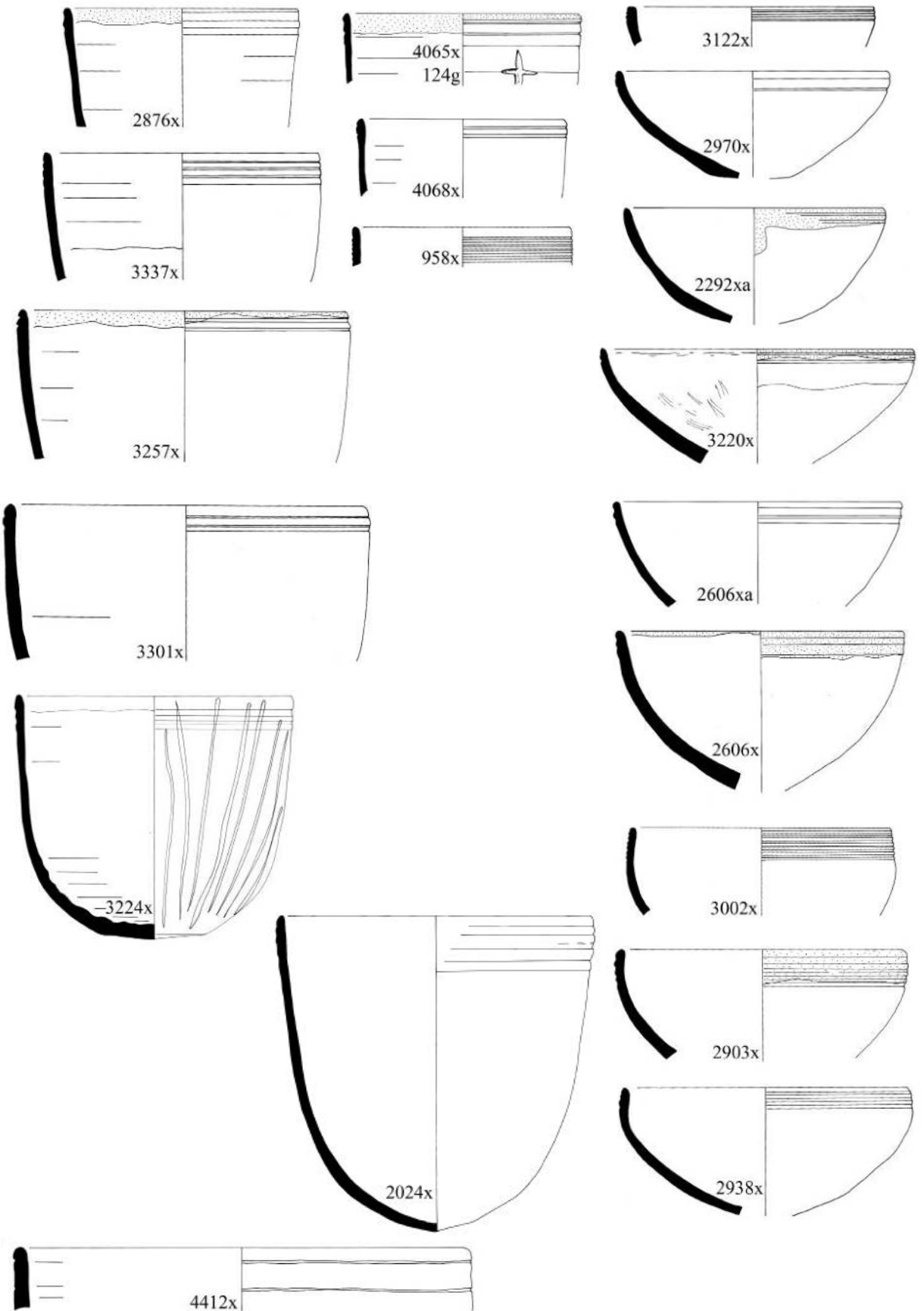

Figure 3.6.8. Bowls with ribbing by the rim, continued from Figure 3.6.7 (scale 1:4).

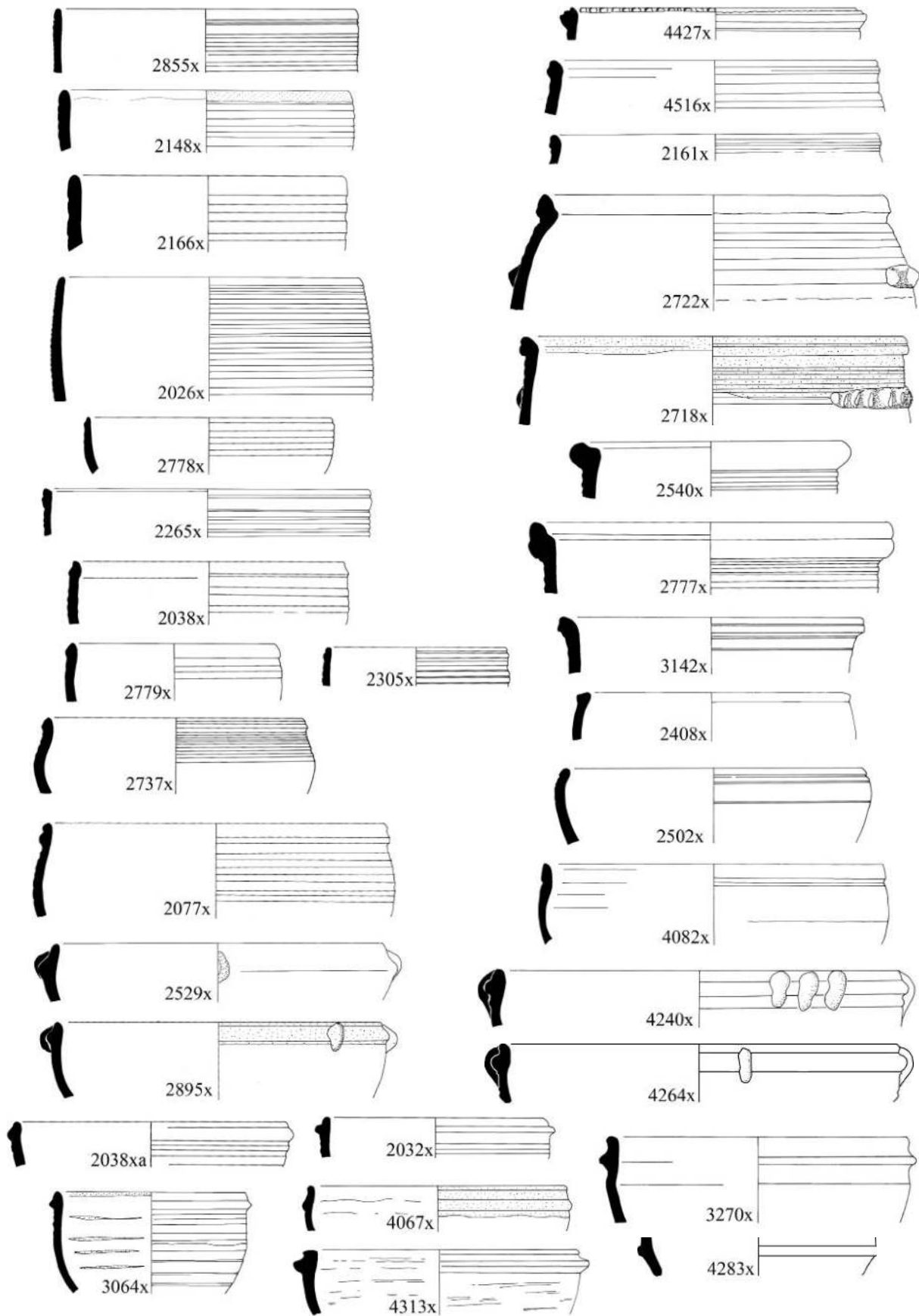

Figure 3.6.9. Ribbed ware and bowls with flanges and bosses (scale 1:4).

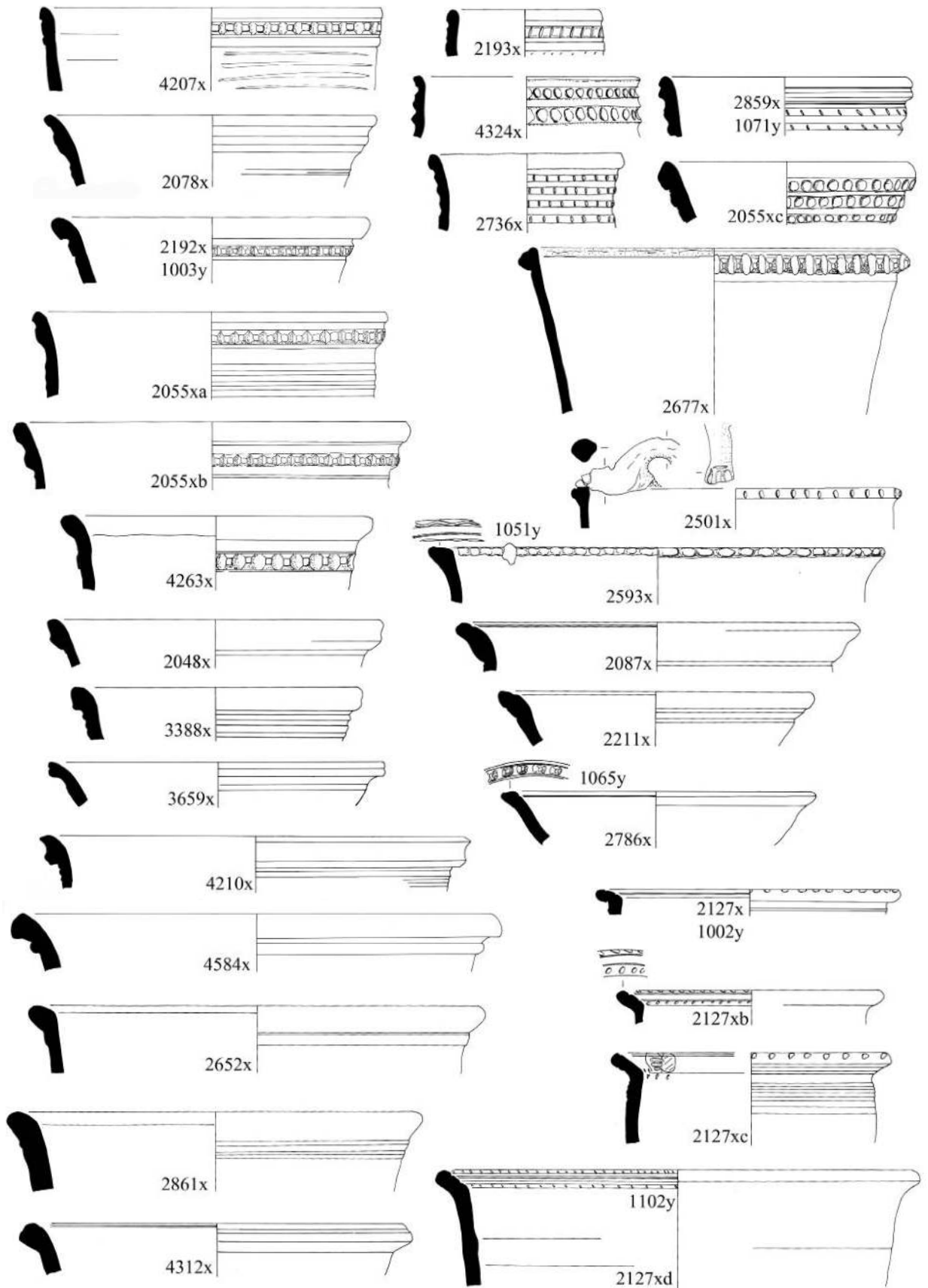

Figure 3.6.10. Bowls with everted decorated rims (scale 1:4).

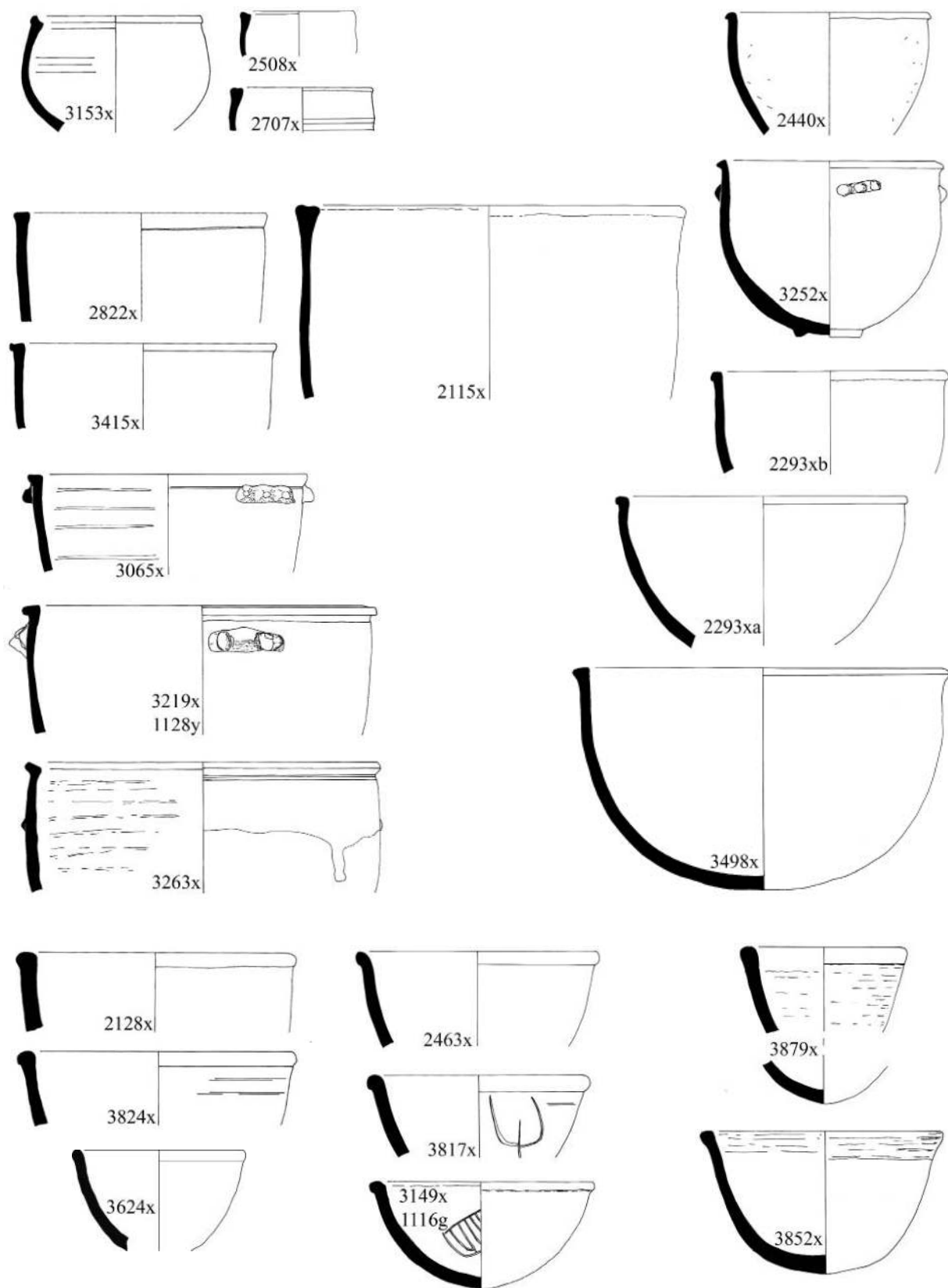

Figure 3.6.11. Bowls with ledge or beaded rims (scale 1:4).

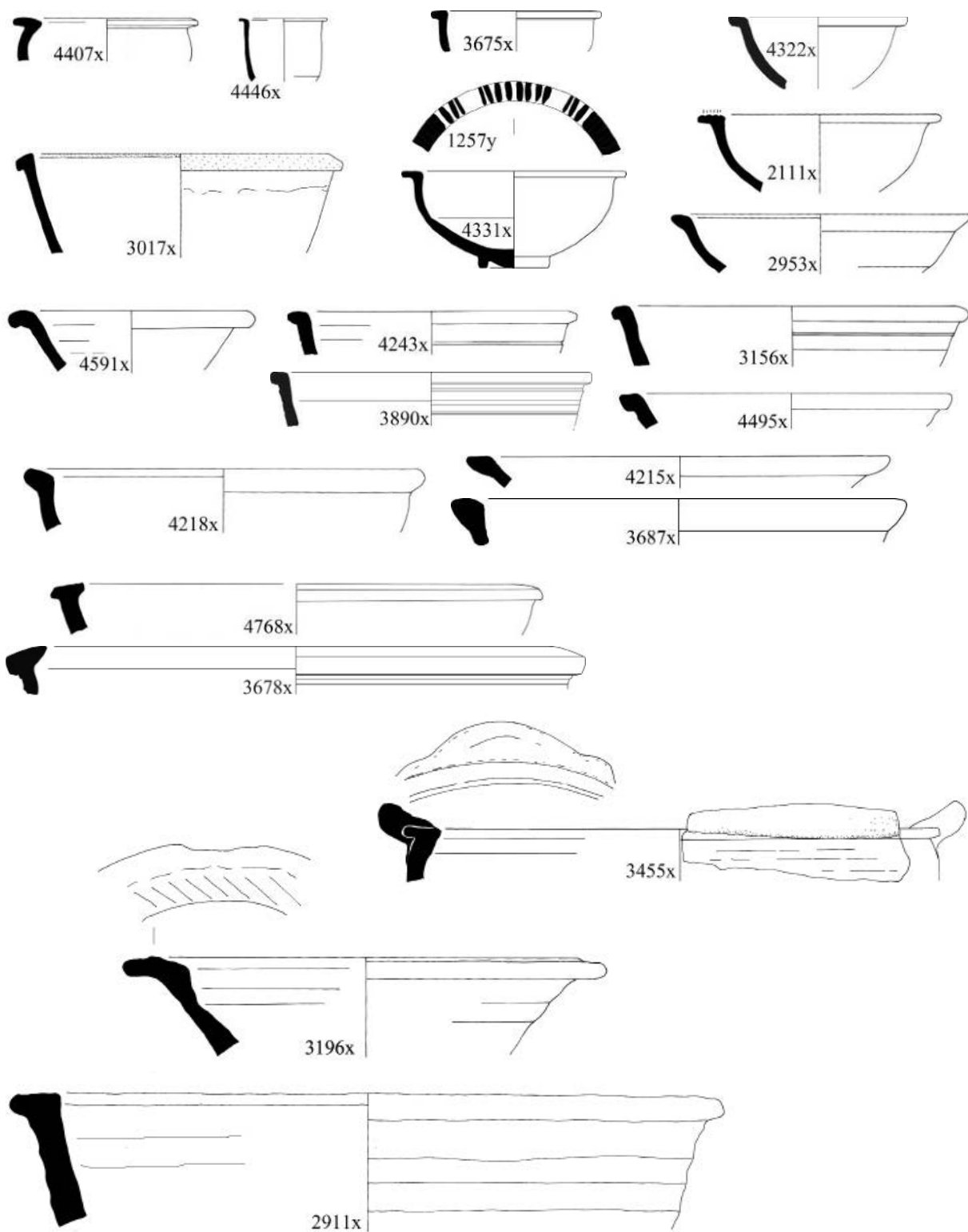
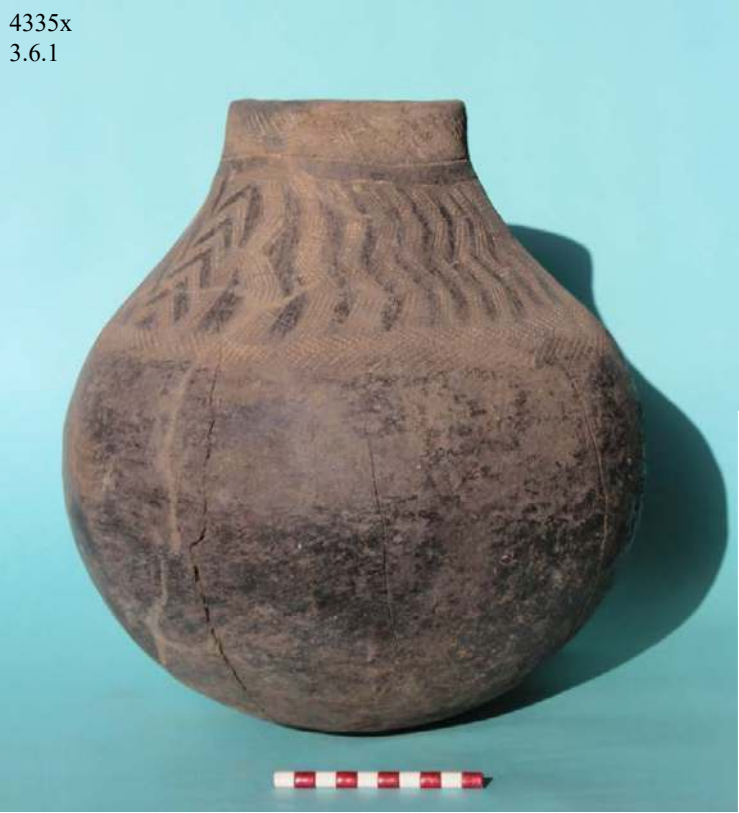
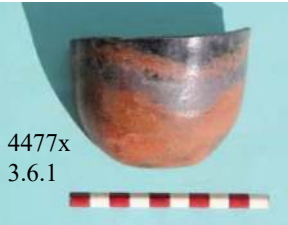

Figure 3.6.12. Bowls and basins with ledge rims (scale 1:4).

4335x
3.6.1



4336x
3.6.1



4477x
3.6.1

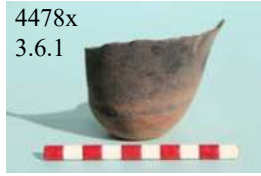

4478x
3.6.1



3143x
3.6.2



4781x
3.6.2



4782x
3.6.2



4785x
3.6.2



4788x
3.6.2



4334x
3.6.2



Plate 3.6.1. Black-burnished jars and a selection of cups.



Plate 3.6.2. A selection of Meroitic bowls and a deep Napatan bowl and beaker, both red-slipped.

TABLE 3.6. DECORATED WARES, CUPS, OPEN BOWLS AND BASINS, HANDMADE AND WHEEL-MADE.

Fig. no.	Type	Provenance	Fabric	Dec.	Surface treatment	Dia.	%	Man.	Comments
3.6.1	BU2.16	(561)2 (HA2)12 -	6	D25.9 D26.3	804E 810I	19-25	8	HM	<i>Kerma Ancien</i>
3.6.1	2653	(AB4)6 (TG5)1	92	1056 1119/1245	800E H805I	8-17	52	HM	
3.6.1	2653a	(AB4)6,20,22 (CE5)1	72 92	1056 1058	800E 802 812	9-11	14	HM	
3.6.1	2959	(AB4)23	1	1081 1155	800E	8.5	36	HM	
3.6.1	3001	(ZH5)38	92?	CROC/R		30	-	HM	
3.6.1	3145	(HA2)54 gr. 55 (TG5)7	42 105	1112	804E 810I	15-18	10	HM	
3.6.1	3146	(HA2)52 -	42	1114		20	6	HM	Neolithic
3.6.1	3147	(HA2)52 -	42	1115 1121	812	24	6	HM	Neolithic
3.6.1	3564	(JE3)24 -	7		806E	9	1	HM	Kerma beaker
3.6.1	3593	(TG5)22	-	1222		14	5	HM	
3.6.1	3612	(TG5)18	-	-		16	-	-	
3.6.1	3697	(JG2)16	6	ABR	804E	13	-	HM	<i>Kerma Classique?</i>
3.6.1	3908	(FQ/R4)2	92	1155	961I	17	5	HM	
3.6.1	+4335	(JH3)76 gr. 21	8	1180-1183	810E	10	100	HM	
3.6.1	+4336	(JH4)1 gr. 1	11	1184-1186	810E	-	-	HM	
3.6.1	4362	(CE5)1	1	1112 1201		14	10	HM	
3.6.1	4363	(CE5)1	1	1200	800E	11	13	HM	
3.6.1	4396	(CF3)1	59	1221		9	9	HM	
3.6.1	4440	(JG2)202,242,265,266 gr. 175	106	1226 1222		17	16	HM	
3.6.1	4458	(CE4)42	92	1227 851		6	12	HM	
3.6.1	+4477	(BE2)32 (CF4)107,109,161	2 6 7		804E 806E 810I 822R	5.5-15	91	HM	Kerma beaker
3.6.1	+4478	(CF4)107	7		806E 810I	3	50	HM	Kerma beaker, reused
3.6.1	4485	(CF4)111,113	1 6		810E 820EBL	10	27	HM	
3.6.1	4545	(CE4)48	92	1240	812	12	15	HM	
3.6.1	4553	(CE4)48	6		800E	8	11	HM	Kerma
3.6.1	4824	(JC3)6	8	1284		13	7	HM	Neolithic?
3.6.1	4831	(AD5)1	110C	1204		15	6	HM	
3.6.2	2022b	(BE2)26,48 (BE3)53,59,78 (BF2)34 (CF4)28 (FP6)95 (FR3)12 (JD2)51 - (JG2)182,183 gr. 150 (TG5)16,65	11 32 69 80 92 94 110		800E 810I 820ER 820IR 820IW 822R	11-25	154	HM WM	
3.6.2	2124	(AB4)23 (AB5)205 (AC6)14 (AD5)14,283 (AD6)5 (BD3)8 (BE2)10,33,104,109,110 (BF3)8 (FO7)1 (FQ4)26 (TG5)29-105,87,122 (ZH5)40	1 2 67 69 80 92 92F 110		802 820ER 822R RBRIE	10-17	160	HM WM	
3.6.2	2235	(AB4)1,7,11,23 (AB5)1,3,14,35,40,66,80,229 (AB6)3 (AC6)1,14,20,27, 30,37 (AD5)161,227,268 (AD6)5 (BC2)2,4 (BC3)3 (BC4)1 (BD2)28,29,71,94,101 (BD3)5,9,28 (BD4)17 (BE2)17,48,50,57,71,73,103,117,158 (BE3)10,16,18,27 (BE4)9,16,19 (BF1)56 (CF3)6,8 (CF4)1,51,56,73 (FO6)145 (FR3)1,14,15,22 (FS3)1,2,3,14 (FT3)5 (TG5)73,76 (ZH5)43 (HA1)1098 4	1 2 11 25 56 65 67 69 79 80 92 94 95 110	1037 850	820ER H820ER 822gr. 822O 822R V822R 825EW 825ER 825EIR 830EW 820IW 910 RBRIE	9-28	1327	HM WM	

Fig. no.	Type	Provenance	Fabric	Dec.	Surface treatment	Dia.	%	Man.	Comments
3.6.2	2452	(AB5)38 (AD5)1,160,193 (BD4)19 (BE3)18 (CF4)139 (FR3)12	1 65 69 92			10-25	73	HM WM	
3.6.2	2504	(AB6)1 (AC6)31 (AD5)87,227,272,273 (BE3)55 (FR3)28 (FS3)6 (TG5)5/4	1 14 27 92 92F 94		820ER H820ER 820IO 822W RBRIE	7-14	88	HM WM	
3.6.2	2545	(AB5)20,58 (BE1)73 (BE2)103 (CE4)85,86 (CF4)109,138 (FP8)1 (FR3)13 (TG5)5/4,12 (ZH5)37	65 69 92 110		820ER 820IR 820IBL H820ER 822R 822W 825EIR 910	11-20	117	HM WM	
3.6.2	2662	(AB4)7 (AC5)17 (BC2)2 (FO6)172 (FR3)14 (FT3)3,22,67	92 110		820ER 825EW RBRIE	5-18	145	HM WM	
3.6.2	2685	(AB4)10,23	69 92		820ER	7-8.5	72	WM	
3.6.2	2712	561 2 (FP6)9 (FT3)22	33 92 107		820R 822R	10-13	83	HM WM	
3.6.2	2790a	(AB5)233 (AC5)17 (JG2)265 gr. 175	69 92 97	chequer board 820ER	820EO 820ER 825ER RBRI	14-17	36	WM	
3.6.2	2840	(AB4)23 (AB5)229,233 (AC5)17 (AD5)161A (AD6)4 (FP6)10,21,138 (FR3)14,22 (TG5)77	65 69 80 92 92F		H820ER 822R 825EIR 825EP RBRIE	9-18	252	HM WM	
3.6.2	+3143	(HA2)45 -	88		H820ER	14	18	WM	B 100%
3.6.2	3217	(AD5)34,154 (CE4)1 (FP6)70 (FQ3)3 (TG5)4,12	92 94F 110		820ER 822R	-20	71	HM WM	
3.6.2	3239	(AC5)34 (AD5)28 (BE2)1,43 (BF3)8 (TG5)6,100	67 69 80 92 94	1000	H820ER 820ER 820IW 822P RBRI	12-22	74	WM	
3.6.2	3331	(AD5)113	92		825ER	16	11	WM	
3.6.2	3370	(AB4)31 (AC5)36 (FP6)89 (HA2)1 (TG5)91	70 92 94		802 804E 8101 820ER H820ER RBRI	17-25	45	HM WM	
3.6.2	3423	(AD5)272 (AD6)13 (FP6)9 (TG5)1,4,117	92 92F 98		H820ER 820EBL RBRIE	8-16	114	WM	
3.6.2	3527	(CE4)1 (HA2)217 gr. 214	25 92	1192	820RV 810I	10.5- 15	103	HM	
3.6.2	3533	(HA2)227 gr. 207	92		820EW RIBBED	13	8	WM	
3.6.2	3535	(HA2)137 gr. 55	106		820EBL 820JGR	14	23	WM	
3.6.2	3570	(JE3)34 gr. 115 (JF2)36 gr. 20	15F.26		820ER 820IP 820IW	9	53	WM	898 (JC2)2 BS
3.6.2	3621	(HA2)226 gr. 67	85		H820ER 820IW	8.5	35	WM	
3.6.2	3699	(JG2)4 gr. 2	139	1178	820EO	9	14	WM	
3.6.2	3805	(AC5)127 (AD5)272,276 (FO6)47 (FP6)1 (TG5)95	92 92F 94		H802 R802 825IR	8-18	48	WM	
3.6.2	4096	(FO6)37	-		H822	11	-	WM	
3.6.2	4103	(FP6)9,24	113			16	33	WM	
3.6.2	4180	(FP6)8 (TG5)117	92			12-13	76	WM	
3.6.2	4291	(JH3)39 (39)	92F		822R RBR TOP	12-13	21	WM	
3.6.2	+4334	(CF3)1	139			9.4	65	WM	
3.6.2	4368	(CF3)1	111		820EBR	7	30	WM	deformed
3.6.2	4409	(CF4)50	130		820ER 825IER	5	24	WM	

Fig. no.	Type	Provenance	Fabric	Dec.	Surface treatment	Dia.	%	Man.	Comments
3.6.2	4460	(BF3)9 (CE4)14	80 94		822EO	8-15	20	WM	
3.6.2	4569	(CF4)163 (JD2)43 gr. 40	92 106		820EP 820IW	11-14	38	HM WM	
3.6.2	4595	(CF3)49	115		820EP/825EW 825IP	6	10	WM	
3.6.2	4764	(JF2)36 gr. 20	26	1263	RBRE	8	24	WM	mould-made?
3.6.2	+4781	(GD3)79A gr. 11	92		800EH 805IH sparse	10	100	WM	
3.6.2	+4782	(GD3)107B gr. 98	92		H800E H800I	13	100	WM	
3.6.2	+4785	(GD3)70A gr. 45	26	1270 1271 1272		9.5	100	WM	
3.6.2	+4788	(GD3)1	26	1273 831E		9	27	WM	
3.6.2	4795	(GD3)0,1,125 gr. 119/136,141 gr. 138,153 gr. 20	132		825EW	9	35	HM	999
3.6.2	4832	(JE2)2,4 (JF2)36 gr. 20,51 gr. 55	106		H822GR	11	18	WM	999 & 898
3.6.2	4833	(FZ1)10,25	110	252g	804E 810I	10.5	57	HM	999
3.6.3	2045	(AB4)1,6,7,10,23,31 (AB5)1,3,5,35,40,42,45,58,66,80,89,229,230,232,2 33,317 (AB6)3,27,63 (AC5)12,13,28,49,65 131 (AC6)1,7,17,36,37,45,57 (AD5)41,49,87 (AD6)5,13 (BC2)2 (BD2)49,65,71,89,97,100,101 (BD4)19 (BE2)1,17,24,30,40,48,50,57,100,101,105,114,121 (BE3)17,50,55,57,65,78,104, 136 (BE4)9,14 (BF1)4,6,53,61,73 (BF2)2,11,22,31,47 (BF3)8,9,11,38,50,52,56,58 (CE4)71 (CF5)1 (FO3)58 (FR3)1,12,14 (FT3)6 (HA2)68 gr. 204, 95 gr. 94 (JG2)287 - (TG5)6,29-105,73,122 (56)12	2 9 25 65 67 69 72 80 81 92 92F 92L 93 94 95 106 110	1210 700E	804E 805E 812 820E CR 820E R 820EP 820EW 822R 825EIP 825EIR 825Egr. RBRIE	6-22 (23-31)	1652	HM WM	
3.6.3	2047	(AB4)7,15,19,20,31 (AB5)1,35,42,66,80,89,223,229,230,231,273,302,328 (AB6)1,27,63 (AC5)8,12,13,177 (AC6)7,23,61 (AD5)113,132, 276 (AD6)1,4,13 (BD2)71,81,99,100, 101 (BD3)8 (BE2)10,48,117 (BE3)1,13,27,40,50,64,67 (BF2)31,47,49 (BF3)30,38,52,56,58 (CE4)58 (CF3)13 (CF5)1 (FO6)92 (FP7)12,100 (FQ3)48 (FR4)2 (FS3)3 (TG5)9,45,86-99,91,122	1 9 11 14 22 65 67 69 80 92 92F 94 110		805E 820E R H820E R V820E R 822R 822 W 825E P 825E R 825E W 825EIR 820IW RBRIE BL TOP	6-23	794	HM WM	
3.6.3	2215	(AB4)1 (AB5)4,27,64,72,80, 218,241 (AC5) 73,145 (AC6)4,8,59 (AD5)162 (AD6)12 (BC4)1 (BD2)2,4,96 (BE2)53,73,78 (BE4)9 (BF2)11 (BF3)38 (CF3)4,(CF4)141 (FP6)34 (FP7)23 (FQ4)37 (FZ1)9,24 (TG5)29,112	11 67 69 92 94 110		800E 820IR 820ER 822R 825EIR 825IR 830EP 910 CRR RBRI RBRE RBRIE	11-24	279	HM WM	
3.6.3	2289	(AB4)7 (AB5)25,32,67 (AC6)17,40 (BD2)82 (BE2)48 (BE3)18,106 (BE4)9	2 61 67 69 80 92 94		820IR 825IR RBRIE	13-25	312	HM WM	
3.6.3	2292	(AB4)7,20,27 (AB5)45,46,58, 215,216,317,328 (AB6)1 (AC5)8,13,18,23 (AD5)1,21 32/160,34,54,56,117 (BD2)26 (BE2)26,87 (BE4)42 (FR3)1 (FS3)1,3 (FT3)4,7,8,25 (FZ1)2 (HA2)45 -,120 gr. 119 (TG5)44 (AB5)32	56 65 69 80 90 92 94 110		820IW 822BL 822R 825EIR RBRIE	13-25	594	HM WM	(BD2) lamp use? (AD5)21 IB bowl?
3.6.3	2562	(AB5)20 (FQ/R4)2 (FR3)1	95			20	20	WM	
3.6.3	2580	(AB5)20 (FQ/R4)2 (FR3)1	69 92	851	822O RBRIE	18-23	23	HM WM	
3.6.3	2681	(AB4)10 (AB5)273,317 (AC5)12,55 (AC6)36 (AD5)4,28,128,132,151,198,226 (AD6)11 (BD2)26 (BF3)9 (CE4)42,47 (FQ/R4)2 (FR4)2 (FS3) 1,11 (FR3)15 (FT3)1,4,44 (HA2)187 - (TG5)87 (ZH5)45	25 9 80 90 92 94 94C 97 110		820IR 820E R 822R 825EIR CRR RBRIE RBRI	11-29	214	HM WM	

Fig. no.	Type	Provenience	Fabric	Dec.	Surface treatment	Dia.	%	Man.	Comments
3.6.3	2791	(AB4)27 (AD5)112 (BD2)45 (FN6)6	69 92 94 110		822R 825EIW	11-21	105	HM WM	
3.6.3	2794	(AB4)23,28 (BD2)29	69 92 94		H820IR 820IR 822W RBRE	19-25	88	WM	
3.6.3	3005	(AB5)231,233	92		H822R	19-21	68	WM	
3.6.3	3012	(AC5)17 (FR4)1	69 92		H820IR 820IRV 825ER	16- 16.5	106	WM	(AC5) complete
3.6.3	3094	(AD5)7 (BE3)49,57 (BF2)37 (FQ3)42 (FR4)2 (FZ2)1 (JE2)11 - (TG5)29,74	67 69 80 92 110	834ER	820ER H820IR 822R H822R 822W 825ICR 910	8-20	91	HM WM	
3.6.3	3098	(AD5)7,10	92			17-19	23	WM	
3.6.3	3127	(ZH5)45	67	BOSS	820ER 820IBL	17	12	HM	
3.6.3	3134	(ZH5)53,93	80 92		822BEIGE 825EIV	14-15	24	WM	
3.6.3	3152	(AC6)71 (BE3)63 (CF4)21,133 (CF5)2 (FO6)53 (FP6)146 (FP7)95 (FQ4)79 (HA2)78 gr. 79 (TG5)85-94	42 59 92 94 110	1097 850	OBL 800E 910 RBRIE	12-23	186	HM	
3.6.3	3154	(BE4)12 (BF3)9 (FO6)116 (HA2)68 gr. 204	1 69 72 92	1121 931E	812 822R 825EIP	14-29	38	HM WM	
3.6.3	3292	(AD5)21	92			18	7	WM	
3.6.3	3377	(AC5)39 (FQ3)48 (TG5)75	69 92 94		V820ER H822R 825EIR RBRIE	14-17	42	WM	(FQ3) from brick
3.6.3	3381	(AD5)112 (GD3)44 gr. 41 (JE3)24 -	69 92		800I H822R	12-30	27	HM WM	
3.6.3	3420	(AB5)273 (AC5)67 (AD5)190,207,248 (CE4)47 (CF3)30 (CF4)26,108 (FO6)92 (FP6)9 (HA2)79 gr. 210 (JD2)43 gr. 40 (JE2)9,15 gr. 14 (TG5)1,5,4,6,65,73,77- 96,114	40 69 92 92F 94 106 107 110 130	1017	R805E 812 820EW H822R 822W 825ER 825EIR RBRIE	10-20	190	HM WM	
3.6.3	3440	561 8 (AB4)23 (AD5)317 (BE2)1 (BE3)57 (BE4)14 (BF3)50 (CE4)2 (CF3)5 (FO6)132 (FO7)69 (FP6)155,159 (FP7)1 (FQ3)7 (FQ4)64,79,80 (FS3)3 (GD3)44 gr. 41 (TG5)1,35,57,65,73,74,75,91,114,144	1 7 42 67 69 88 92 94 94F 110	1036 1217 1218 1222	804E 810I 812 822P 822R 825EIR 910 CRR RBRIE	11-26	215	HM WM	
3.6.3	3503	(HA2)79 gr. 188,215 gr. 269	5		800E	14	11	HM	Neolithic?
3.6.3	+3518	(BF2)15 (HA2)74 gr. 67	31 92		820ER 820IR	16,5- 21	65	WM	
3.6.3	3696	(HA2)1 (JG2)22,25,39,42 gr. 2	6			22	26	HM	Neol / Kerma?
3.6.3	3723	(AD5)242 (FP6)154 (FQ3)43 (TG5)46,74-90,76,77-96	2 92 94 110		822R 825ER 910	15-19	48	HM WM	
3.6.3	3905	(CE4)20 (CF4)18 (FP7)82 (FQ4)21 (FR4)1 (TG5)4	65 92 94F 110		820IW 822P 822R 825EIR 910	16-23	60	HM WM	
3.6.3	3942	(FO4)78 (GD3)46 gr. 45	110			15-20	42	HM	
3.6.3	3962	(CE4)4,48 (CE5)1 (CF3)1 (CF4)113 (CF5)1 (FQ3)60 (TG5)1	67 110 117		820ER 820IR	16-30	87	HM	
3.6.3	3984	(TG5)73	-	119g		15	-	-	
3.6.3	4057	(TG5)73	92			17	3	WM	deformed

Fig. no.	Type	Provenance	Fabric	Dec.	Surface treatment	Dia.	%	Man.	Comments
3.6.3	4063	(BF2)15 (FP7)31 (TG5)73	92 94		820ER/W 822R	15-19	24	HM WM	
3.6.3	4083	(TG5)73	92	831EBL	820ER	18	22	WM	
3.6.3	4113	(FO6)91	92F		R805EI	17	10	WM	
3.6.3	4206	(TG5)102	-			12	-	-	
3.6.3	4273	(TG5)77	130		H820ECR	16	6	WM	
3.6.3	4390	(CF3)5 (JD2)1 (TG5)12	92 94F 113		825EIBR	19-25	22	WM	
3.6.3	4430	(CE4)14 (FP7)82 (TG5)1	69 92F 110		H820EO 822R	9-17	22	HM	
3.6.3	4455	(CE4)20 (FP7)136 (TG5)4,12	65 92 94	1226	820ER 820IW 910	11-17	35	HM WM	
3.6.3	4793	(GD3)1	110		822R	19	12	WM	
3.6.4	2001	(AB5)4 (AC5)171 (AD6)5 (BD3)16 (BE2)56,116 (BE3)16,18 (BF1)13,75 (BF2)1,22,56,75 (BF3)50 (CE4)2,9 (CF4)95 (FP6)89 (FP7)152 (FT3)22 (TG5)94 (ZH5)62	67 69 92 94 106 110	5VAR boss	822R 910 RBRIE RBR TOP	14-31	236	HM WM	
3.6.4	2002	(AD5)112 (BE2)21 (BE3)21,50 (BE4)1 (BE2)1,16,33 (BF3)9,58	1 67 69 92 93	850	RBRIE RBR	17-36	70	WM	
3.6.4	2066	(AB4)10 (AB5)4,32 7 (AD5)67 (BD2)29,32 (BD4)13 (BE3)16,55,136 (BE2)31,38 (CE4)58 (CES)1 (FQ3)24 (TG5)74	67 69 92 94 94C	850	802 820IR 822R 822W 830E	16-26	150	HM WM	
3.6.4	2072	(AC6)22,30,37 (AD5)207,227 (BD2)3,23,28 (BE1)18 (BE3)1,16,130,136 (BE4)9,14 (BF1)33 (BF3)8,9,15,17 (CF4)100 (FP7)0 (FQ3)42 (JD2)16,26 gr. 12 (TG5)5/4,57,74,75,119	2 32 61 67 69 92 94 106 110		802 820ER 820IP 820IR 822R 825EIW RBR	13-25	394	HM WM SW	
3.6.4	2090	(AB6)1 (BE2)56 (BF2)20,37 (BF3)8,9,50 (CF4)100 (JC3)15 (TG5)52,103	69 81 92 92F 94 94L 105		820IR RBRE	17-32	62	HM WM	
3.6.4	2102	(AB5)66 (AD5)198 (BE2)26,105,156,158 (BE3)10,65 (BE4)20 (BF3)38,50 (FP6)154 (FQ4)112 (FZ2)1 (HA2)187 - (ZH5)60	1 2 25 61 92 94 110		800E 805I 822R 825EI	13-38	146	HM WM	
3.6.4	2269	(AB4)10,11 (AB6)11 (AC5)8 (AC6)14 (AD5)112,160,167 (BE2)38,116 (BE3)18 (BE4)29 (FT3)1 (TG5)94	65 67 69 88 92 94C	1112	802 822R 825EBL 825EIBL RBRIE	14-40	143	HM WM SW	
3.6.4	2286	(AB5)239,248 (AC5)28 (BD2)29 (BE2)48,67 (BE3)1,10,16 (BE4)1 (BF1)4,30 (CF4)1	2 65 69 92 94 95 97 110		820ER 822P 822R 825EIW	12-25	234	HM	
3.6.4	2325	(AB4)31 (AC5)127,164 (BD2)47,50 (BE1)6 (BE3)16 (BE4)9 (BF3)9 (CF4)17 (FR3)14	11 67 92 92C 93 110	5VAR	800E 810I 825EIW 825EICR 910 RBR TOP	15-28	126	HM WM	
3.6.4	2403	(AB4)22 (AB5)32 (AC6)1 (AD5)272 (BE1)1,6,7 (BE2)48,67 (BE4)60 (BF1)5,6,11,28,35,45 (FP7)19 (FQ3)8 (FR3)1	1 45 67 69 80 92 94		820ER 822R 822W 910 RBR	16-30 (40)	204	HM	
3.6.4	2427	(AB5)59 (BD3)16 (BE1)6,85 (BE3)27 (CE4)85 (FQ3)7 (FR3)1	67 69 92 95 105	850	802 910 RBRIE	14-27	71	HM SW	
3.6.4	2563	(AB4)6,7 (AB5)24,25,32,80,86 (AC5)126,171 (AD5)256 (AD6)16 (FO6)2,13,15,41,73 (FP6)89 (FQ3)58 (FR3)4 (FR4)1 (TG5)1,127 (AB5)20	11 92 92C 106 110		910 RBRIE RBR TOP	13-33	174	HM WM	
3.6.4	2579	(AB5)20	69			16	11	WM	
3.6.4	2613	(AB4)5 (AB5)89	69 92		822W	8-10	37	WM	

Fig. no.	Type	Provenance	Fabric	Dec.	Surface treatment	Dia.	%	Man.	Comments
3.6.4	2618	(AB4)23 (AB5)23 (AD5)246,268	69 83 92		825ER	14-24	37	HM WM	
3.6.4	2742	(AB5)328 (AC5)17,80 (AD5)269 (BD2)28,59 (BF1)16 (CF4)88 (TG5)1	67 69 94 110	931E 1204	822O 822R H822R	10-23	104	HM WM SW	
3.6.4	2761	(AC5)94 (AC6)54 (BF2)56 (FQ4)2 (FR4)1	69 92 94		820ER 822R RBRIE	14-27	61	HM WM	
3.6.4	2908	(AB4)27 (AC5)164 (AD5)269 (BE3)31,56 (CE4)58 (FS3)3	92 110		822R RBR	11-19	50	HM WM	
3.6.4	2946	(AB4)23 (AB5)231,233,279 (AD5)1,28	76 92			11-15	158	WM	
3.6.4	2966	(AB4)23 (AB5)230,231,233 (AC5)82 (AD5)1,28,260 (CE4)1	69 83 92 92F 94	1190	820IR 825EBL	14-30	184	WM	
3.6.4	3043	(AB5)273	92			14	12	WM	
3.6.4	3070	(AD5)1	94 97		825EIBR	17	127	WM	
3.6.4	3275	(AD5)69	92			13	6	WM	
3.6.4	3285	(AC5)59	92		H820ER	16	7	WM	
3.6.4	3351	(AD5)160 (FO6)91	92 92FL			10-19	21	WM	
3.6.4	3922	(CF3)41 (FQ4)63	95 105 106		822R	15-25	13	HM WM	
3.6.4	3950	(CF5)4 (FP6)154 (HA2)79 gr. 188,83 gr. 84 (TG5)29-74,44	42 48 92 94 110		820R 825EW	12-30	22	HM WM SW	
3.6.4	4164	(FO6)125	92		825EIW 825IR/W	13	15	HM	
3.6.5	2034	(AB4)15,20 (AB5)40,58,59,80 (BE2)1,109	65 69 88 92 93		825EIP CRBRIE RBRIE	14-30	106	WM	
3.6.5	2049	(BC4)1 (BD2)49 (BD3)16 (BE2)21 (BF3)8,9	2 25 67 69 92 94		822R 822W RBRE	17-25	58	HM WM	
3.6.5	2053	(BE2)48 (BE3)1	14 69		822P 822R	20	17	WM	
3.6.5	2059	(BE3)26 (BF2)11 (BF3)38 (FP7)10	67 69 76 110		822R 910 RBR	17-20	151	HM WM	
3.6.5	2065c	(BD2)26 (BF2)38 (BF3)1	69 80 92 94		822R 825EICR	13-21	45	WM	
3.6.5	2065b	(AC4)1 (BE1)9 (BE2)67 (BF3)38	9 13 65 69		822O 822W 830ECR RBRIE	15-20	25	WM	
3.6.5	2065	(AC6)22 (BC2)1 (BD2)26,71,101 (BD3)9 (BE1)18 (BE2)33,57,67 (BF1)6,53 (BF2)15 (BF3)8,17,78 (ZH5)45	25 32 69 80 92 94		820EW H820IR 822BL 822P 822R 822W 825ER 825EIR RBRIE	11-26	186	WM	
3.6.5	2067a	(BC3)2 (BD1)101 (BD3)33 (BF1)6,11 (TG5)85	9 67 69 80 92 94		820IW\ 825IR 822R 825EIR	20-26	68	HM WM	
3.6.5	2100	(AC5)55 (BE1)1 (BF1)4,45 (BF3)56	69 94		822R 825ER 825EIR 825EIO	19-24	36	WM	

Fig. no.	Type	Provenance	Fabric	Dec.	Surface treatment	Dia.	%	Man.	Comments
3.6.5	2140	(BC4)1 (BD2)79 (BE2)25,31	29 69 93		822R 822W 825IR RBRIE	18-22	27	WM	
3.6.5	2145	(BE2)45 (BE3)16 (FR3)2	1 80 93			10-27	22	HM WM	
3.6.5	2160	(BD2)28,71 (BE2)26,50 (BF3)9	13 25 65 69 80 92		820ER 822R 822W 825IR RBR	14-21	36	WM	
3.6.5	2182	(BC2)4 (BD2)50 (BE3)10 (BF1)11 (BF3)59 (TG5)74-90	65 69 88 92 93 115		820ER 820EY 820IR 820IW 822R 822W RBRIE	15-23	48	WM	
3.6.5	2186	(BF3)50 (TG5)73	83 92		820EW RBR	11-15	17	WM	
3.6.5	2351	(BE3)132	80		822CR/P	9.5	31	WM	
3.6.5	2481	(AB5)14,59,239,292 (AC5)12 (BD2)50,80,82 (BE3)16 (TG5)46	69 80 92		820ERBL 820IR 822R 822W 825EIR RBR	13-27	136	WM	
3.6.5	2787	(BD2)28	16	punctated int pre-slip	820ER 820IW RBR	12	16	WM	
3.6.5	3183	(FR3)2	92		H822BR	23	6	SW	
3.6.5	3266	(AC5)53 (FQ4)24 (TG5)5/4	67 92 94		820ECR 825EIR	12-25	51	HM WM	
3.6.5	3316	(AD5)87	65		820IW	15	11	WM	
3.6.5	3340	(AD5)136	17			23	6	WM	
3.6.5	3368	(AC5)1 (JC3)6	92 121			19	10	WM	lid?
3.6.5	3430	(AD5)168	92			25	9	WM	
3.6.5	3494	(AD5)198 (CE4)98	92 94		910	20-23	17	HM WM	
3.6.5	4048	(TG5)91	91		820EW RBRIE	15	11	WM	
3.6.5	4081	(TG5)73	92			10	11	WM	
3.6.5	4087	(TG5)94	-			25	-	WM	
3.6.5	4235	(TG5)102	-			10	-	WM	Egyptian import
3.6.5	4262	(TG5)85	16		820ER 820IP	14	10	WM	
3.6.5	4315	(TG5)74	65		825EW	24	3	WM	
3.6.5	+4540	(JF2)87 gr. 79	94	R splashes ext.	825ICR	19x 20.5	100	WM	
3.6.6	2122	(AB5)20 (BE2)26 (BE3)57 (BF3)52	69 92		822R 822CR 832R	11-19	34	WM	
3.6.6	2153	(BF3)9	80			22	7	WM	
3.6.6	2155	(AD5)205 (BC2)4 (BE1)41 (BF3)9 (FQ4)33 (TG5)76,114	69 92 94		820EBL 820ER 820EW 822R	13-23	59	HM WM	
3.6.6	2199	(BE2)104 (BE3)104 (BF3)8	13 49 80		820W	6-8	22	WM	
3.6.6	2300	(AB5)52,252 (BE2)121 (BF1)30,57 (BF3)33	65 66 69 80 92		820EO 820ER 822O 825EO	10.5- 20	71	WM	

Fig. no.	Type	Provenance	Fabric	Dec.	Surface treatment	Dia.	%	Man.	Comments
3.6.6	2485	(BE3)16 (BF2)56	69 94		800E	10-18	26	HM	
3.6.6	2525	(BE2)48 (TG5)114	80 94		820ER	18	10	WM	
3.6.6	2541	(BE2)73 (TG5)114	33 95			6.5	30	WM	
3.6.6	+2597	(AB4)6,10 (AB5)58,273 (AC5)12 (TG5)91	65 69 92 94		800E 802 820ER H820ER 825ER	9-22	229	WM	
3.6.6	2705	(AC5)12 (BD2)65,71 (BE2)1 (BF2)22,58	13 26 27 52 69 92		820ER 820ECR 820EW 822W 825ER	8-16	52	WM	
3.6.6	2766	(BD2)36,80 (BD3)5	65		8201W 825EW RBRIE	7	50	WM	999 (not 80) deformed
3.6.6	2766a	(BD2)80	-	1070		-	-	-	
3.6.6	2769	(BD2)23,80 (BD3)9 (BF1)11	53 69 92	lug	820ER 822R 825ER/ 822W	14	20	WM	
3.6.6	2935	(AB4)31	69		820E	-	100	WM	
3.6.6	2945	(AB4)23 (TG5)114	92 94			33	28	WM	
3.6.6	3026	(ZH5)1	-			20	-	WM	
3.6.6	3048	(AB5)328	69		H820EO	9	20	WM	
3.6.6	3180	(FR3)2 (TG5)74	65 94		822P 822R	17-19	20	WM	
3.6.6	3349	(AD5)160	69			29	9	WM	
3.6.6	3453	(FR3)12	92		820ER	8	13	WM	
3.6.6	3491	(AD5)198 (TG5)44	65 92		822W	21-22	9	WM	
3.6.6	3623	(TG5)18	67			28	4	WM	
3.6.6	3761	(AC5)73	92		825EIR	15	11	WM	
3.6.6	4062	(TG5)73,87	92	1170	820ER	18	12	WM	
3.6.6	4090	(TG5)94	-			7	-	WM	
3.6.6	4099	(JG2)1 (TG5)95	92F 106			15-21	12	WM	
3.6.6	4205	(TG5)103	-			22	-	WM	
3.6.6	4217	(TG5)102	-			20	-	WM	
3.6.6	4250	(TG5)84	-			10	-	WM	
3.6.6	4310	(TG5)74	94		825ER	21	9	HM	
3.6.6	4442	(JG2)173 gr. 171	26			6	6	WM	
3.6.6	4808	(BF2)31,33	67	lug				WM	
3.6.7	2013	(AB5)43 (BE3)16 (BE4)8 (BF2)1	61 69 92		822R 822W 825EIP 830ER/ CR 820IR	12-22	38	WM	
3.6.7	2165	(BD2)47 (BD3)33 (BF3)50	14 69 80		820EW 822CR 822W	18-22	27	WM	
3.6.7	2198	(BF3)8 (TG5)52	80 92		825EIP 820ER	13	13	WM	
3.6.7	2469	(AC6)20 (BE1)1 (BE3)10	92 94	850		7-25	35	WM	
3.6.7	2617	(AB4)6,10,11,23 (AB5)29,279 (AD5)161A (FS3)2 (TG5)6	67 69 72 92 92F 94F	850	804E 820EY 825EP 825EW 825IR 825ER RBRIE	14-26	216	WM	

Fig. no.	Type	Provenance	Fabric	Dec.	Surface treatment	Dia.	%	Man.	Comments
3.6.7	2644	(AB4)7,10,14,28 (AC5)12 (AD5)1,23,162 (BD2)82 (BF2)51 (HA2)67,203,250 gr. 67 (TG5)4,7,27,65,73,75,77,85,122	1 31 65 67 69 82 94		820EP 820ER 820EW 822R 825EO 825ER 825EIW RBRIE	13-20	214	HM WM	
3.6.7	2647	(AB4)1	94		825ER RBR	15	13	WM	
3.6.7	2738	(AB6)16 (BD2)28,45,(BF1)6,11 (CF4)113 (TG5)73,77,91	69 92 94		820EP 820ER 820IR 820EW 825IP 825EIBF 825EIR RBRIE	12-44	74	HM WM	
3.6.7	2752	(AB5)239 (BD2)70 (BF1)57,61 (TG5)74,86-99	69 92 94		820ER 820EW 822W	14-21	126	WM	
3.6.7	2770	(AB5)41 (AC5)28 (AD5)34	69 92		820ER V820ER 825EP	15 5-8	60 B 80	WM	(AB5)41 unfired
3.6.7	2790	(AB4)23	65		820ER 825ER RBRIE	16-25	76	WM	
3.6.7	2824	(AC5)17,24,68 (AC6)22 (AD5)45,87,116,160 (FR3)15 (TG5)44,65,112	6 65 69 80 92 94		804E 810I 820EP 820EW 825EIBL 825ER 825EW RBRIE	16-32	74	WM	
3.6.7	3028	(ZH5)11	-			8	-	WM	
3.6.7	3047	(AB5)317	80		825EIR	17	8	WM	
3.6.7	+3085	(AB4)23 (AC5)28,39,68 (AD5)160 (TG5)29-205,77,85	80 92 94		820ER 820IR 825ER 825EW RBRIE	15-45	120	WM	
3.6.7	3226	(AC5)36,39 (AD5)21,34,67,112,123,128,136,168	69 92 93 94		820ER 822W 825ER RBRIE	17-26	119	WM	
3.6.7	3321	(AC5)127 (AD5)84 (FQ3)48 (FQ4)75 (FR4)2 (TG5)44,102-105	65 92 92F 94 110		820EW 820I W 825EO RBRIE	14-22	54	WM	
3.6.7	3361	(AD5)146	69		820ER	21	35	WM	B 100%
3.6.7	3373	(AC5)39 (AD5)112 (TG5)114	94 94F		820EW 822R 822W	21-23	14	WM	(AC5) & (AD5) 999
3.6.7	3813	(AC5)93,117	113 129			26-31	10	WM	
3.6.7	3951	(TG5)44,46	92		820ER	10-21	8	WM	
3.6.7	4031	(TG5)73	94		RBR	11	7	WM	
3.6.7	4066	(AC5)52	94			23	16	WM	
3.6.7	4219	(TG5)105	-			15	-	WM	
3.6.7	4246	(TG5)86	-			16	-	WM	
3.6.8	958	(BD2)65,71 (BE2)1 (BF2)22 (BF3)58	13 52 69 92	934E	820ER 820IR 825ER 820EO 820ER 820EY 820E CR 822O 822R 822W 825E CR 825ER 825EW 830EW RBRIE ribbing	13-16	27	WM	
3.6.8	2292a	(AB4)20 (AB5)32,65,80,208 (AC5)1,34,39 (AD5)152,154 (BC4)1 (BD2)23,26,28,32,47,61,63,71,81,82,101 (BD3)4,8,33 (BE1)1,18,61 (BE2)19, 24,33,37,48,59,67,68,103,128 (BE3)18,27,53,55 (BF1)6,11,28,45,56,61,73 (BF2)1,20,23,31,37,38,39,40 (BF3)9,38,50,58	14 22 25 61 65 66 67 69 80 92 93 94 95	1002 splashes		9-30	726	WM	
3.6.8	2606	(AB4)10,28,31,33 (AB5)42,67,80,89 (AB6)63 (BD2)99 (BF1)45 (FP6)111 (TG5)29-74	69 22 65 67 69 92 94	dribble	825EIR 820IP 820ER 820EW 822P 822W RBRIE 820IP RBRIE	11 13-39	35 261	WM WM	
3.6.8	2606a	(AB4)23	65			18	39	WM	

Fig. no.	Type	Provenance	Fabric	Dec.	Surface treatment	Dia.	%	Man.	Comments
3.6.8	2876	(AB5)218 (AC5)49 (AD5)1,112,113,116,167 (FO6)47 (TG5)6,85	67 69 92 92F 94		825ER 825Eigr. 825EW RBR	12-25	85	WM	
3.6.8	2903	(AC5)37 (AD5)10,20,32/160 (BD2)26 (TG5)44,73,91	65 69 92 94		H820IR 820ER 822CR 825ER RBR	15-25	84	WM	
3.6.8	2938	(AB4)31 (AC5)37	69 94		820IR 822CR 825ER RBRJE	20-21	41	WM	
3.6.8	2970	(AB4)23 (TG5)73	69 94		820IR 822W RBRJE	20-22	19	WM	
3.6.8	3002	(AB5)230 (AC5)53 (CF4)159	69 80 93		H800I 820ER 825EW	13-19	36	WM	
3.6.8	3122	(ZHS)37,45	92		825EIR	12-18	9	WM	
3.6.8	3220	(AD5)34	65		820IP	23	9	WM	
3.6.8	3224	(AD5)34	69		820ER	19	32	WM	
3.6.8	3257	(AC5)37,49 (AD5)97,117	69 92 94		RBRJE	20-24	64	WM	
3.6.8	3301	(AD5)12	92			26	9	WM	
3.6.8	3337	(AD5)135 (FO4)33	92 94		820EO H820ER 820IO	20	33	WM	
3.6.8	4065	(TG5)73	92 94	124g	820EP	17	22	WM	
3.6.8	4068	(TG5)73	94		820EP	15	8	WM	
3.6.8	4412	(CF4)31	94		822CR	33	6	WM	
3.6.9	2026	(AB5)1 (BC3)3 (BD2)28,71,81,101 (BE2)112 (BF1)6,45 (BF2)1,11	16 25 61 65 67 69 92 94	850 934E	822W 820EP 825EW 825EIP 825ER 832CR RBRJE	12-22	114	WM	
3.6.9	2032	(BD2)24,101 (BE3)1 (BF1)56 (BF2)8	11 69 92 93	1006 1112	820IR 822P 822R RBRJE	15-17	24	WM	
3.6.9	2038	(BF2)15	92		830ER	20	6	WM	
3.6.9	2038a	(AB4)7 (BD2)24,28 (BF3)52 (TG5)4,73	67 69 94		822CR 825EP 825EIW	15-30	31	WM	
3.6.9	2077	(BD2)28,100 (BD3)33 (BF1)0 (BF2)31	67 69 92 94	934E	830EP 820IW 822R RBRJE	21-27	41	WM	
3.6.9	2148	(AB4)7,11,15 (AC5)12 (BD2)100 (BE2)48 (BE3)78 (BF2)37 (BF3)9 (TG5)46	14 65 69 80 92 94 105		820EW 825EGR 825ER 825EW 825IW RBRE	14-24	113	WM	
3.6.9	2161	(BE2)48 (BF3)9	69 80		820EP	14-24	11	WM	
3.6.9	2166	(AB4)6 (BD2)79 (BE4)9 (BF3)21,58 (FT3)22	67 69 92		820EW 825EW RBR	15-21	32	HM WM	
3.6.9	2265	(BE3)78	92		822R	24	6	WM	
3.6.9	2305	(BD2)79 (BD3)16 (BE3)21	13 92 94		822CR 934E	13-25	18	WM	
3.6.9	2408	(BE2)24	95L		822R	20	6	WM	
3.6.9	2502	(AC6)1	92		822R	22	8	WM	
3.6.9	2529	(BE2)48	92	lug	822R	24	6	WM	
3.6.9	2540	(BE2)67	67		820EW	21	16	WM	
3.6.9	2718	(BE1)44	94	1038	825EIR	28	9	WM	
3.6.9	2722	(BD2)2 (BD3)28 (BE1)51 (TG5)74	67 69 80 94	1038	820IW 820EW 822R 825EW ribbed	22-25	39	WM	

Fig. no.	Type	Provenance	Fabric	Dec.	Surface treatment	Dia.	%	Man.	Comments
3.6.9	2737	(BF1)6	92		822R	19	7	WM	
3.6.9	2777	(BD3)9	94		822W	26	5	WM	
3.6.9	2778	(BD3)16	92		820EW	18	9	WM	
3.6.9	2779	(BD2)80 (BD3)16	69 94		822R	15-19	16	WM	
3.6.9	2855	(BD2)71	92		822BUFF	22	6	WM	
3.6.9	2895	(AB4)23 (BD2)101	65 92		822R 825EIR	17-24	19	WM	
3.6.9	3064	(AD5)1 (TG5)73	92 93		820ICR RBR	14-17	44	WM	
3.6.9	3142	(ZH5)5,53	92		822GR	21-22	6	WM	
3.6.9	3270	(AC5)37,49	93 94			22-23	20	WM	
3.6.9	4067	(TG5)91	92		820ER	19	6	WM	
3.6.9	4082	(TG5)73	94			25	13	WM	
3.6.9	4240	(TG5)86	92		822R	30	6	WM	
3.6.9	4264	(TG5)85	94		822R	25	6	WM	
3.6.9	4283	(TG5)109	94		822R	17	6	WM	
3.6.9	4313	(TG5)74	92		H822R	18	4	WM	
3.6.9	4427	(TG5)29-105	93		822R	21	9	WM	
3.6.9	4516	(CE4)2	94			24	11	WM	
3.6.10	2048	(BE2)21	80		802	25	15	WM	
3.6.10	2055a	(BE2)40 (BF2)40	67 69	1003	820EP 830IW	26	12	WM	
3.6.10	2055b	(BF2)15 (TG5)52	80 94	1003	802 822R	20-29	14	WM	
3.6.10	2055c	(BD2)28,50	69 80	1003 x 2, x 3	825EIP	20-21	32	WM	
3.6.10	2078	(BE4)8 (BF2)31	8 25			13-25	20	WM	
3.6.10	2087	(BD2)94 (BF2)1 (BF3)50	25 65 80	1002		29-30	18	WM	
3.6.10	2127	(BD2)23,28,47,100 (BD3)9 (BE2)32,48,110 (BE3)16,28 (BF1)57 (BF3)8,9	67 69 80 92 94	1002 1011	800I 820ER 820IW 825EIP 825EIR 822R	21-36	135	WM	
3.6.10	2127b	(BF3)7 (TG5)1	69 92	1002 1102	825EIR 832R	20-25	12	WM	
3.6.10	2127c	(BD2)100 (BE3)10 (TG5)65,74	69 71 92L	1003 1022	822R	25-28	19	HM WM	
3.6.10	2127d	(AB5)207 (BE2)32 (TG5)76	92 94	1002	820IR 825ER	20-36	47	WM	
3.6.10	2192	(BF3)8,38	9 69	1003	822R 822P	24-33	19	WM	
3.6.10	2193	(BE1)49 (BF3)8	67 94	1003 1011	825EIBL	11-12	21	WM	
3.6.10	2211	(BC2)2 (BD2)71 (BF3)50	67 92 94		820IR	23-28	22	WM	
3.6.10	2501	(AC5)8 (BF1)31	69 93		820ER	23 H30 x 12	-	WM	cf. 2726x & 4094x (3.12.5)
3.6.10	2593	(AB5)68	92	1051		34	5	WM	
3.6.10	2652	(AB4)6,7	67			34-37	37	WM	
3.6.10	2677	(AB4)10	92		825ER	27	30	WM	
3.6.10	2736	(BF1)6 (TG5)65	25 94	1003	820ER 822R	14-23	30	WM	
3.6.10	2786	(AB5)92 (BD2)28	67 92	1002 1065 1066	825IP	23-26	22	WM	

Fig. no.	Type	Provenance	Fabric	Dec.	Surface treatment	Dia.	%	Man.	Comments
3.6.10	2859	(BD2)50,89	83 92	1071	820EP 825EW	9-18	56	WM	
3.6.10	2861	(AB4)23 (BD2)101 (FP6)111	9 67 110		825EGR	22-37	31	HM WM	
3.6.10	3388	(AD5)112	100		825EW	21	26	WM	
3.6.10	3659	(TG5)7,18	92			30	6	WM SW	
3.6.10	4207	(TG5)96	-	1003/1071		25	-	WM	
3.6.10	4210	(TG5)103	-			31	-	WM	
3.6.10	4263	(TG5)85	94	1003	820EP	23	6	WM	
3.6.10	4312	(TG5)74	67			28	5	WM	
3.6.10	4324	(CF4)117 (TG5)1	67 94			25	4	HM	
3.6.10	4584	(CF4)101	67			35	10	WM	
3.6.11	2115	(BE3)16 (BE4)14 98/1/4.49	69			36-38	15	HM WM	
3.6.11	2128	(AB4)23 (AB5)66 (AB6)9 (AC5)45 (AC6)16 (BE3)1,10,16,17,27,28,33,37,49,50,56 (BE4)13,16 (BE3)9 (CF3)13 (CF4)17 (FR3)2 (TG5)1	1 2 56 66 67 69 71 76 92 94	1003 1066 1068 850	820IR 822R	18-40 (60)	266	HM WM	(BE3)10 & 27 999
3.6.11	2293b	(AB4)10,11 (BE3)55 (BE4)42 (CF4)27	61 65 69 80 110	air hole	820IR	17-33	78	HM WM	
3.6.11	2293a	(AB5)65,66,67 (AC5)13 (AC6)50 (BE4)9 (FR3)1 (FS3)1	65 67 92 94		822W RBRIE	21-37	68	HM WM	
3.6.11	2440	(AB5)20 (AC5)13 (AD5)1 (BE3)10	1 69		820ER	9-23	148	HM WM	
3.6.11	2463	(BE3)10	1			17	6	WM	
3.6.11	2508	(AB6)1	80		820EW	8	11	WM	
3.6.11	2707	(AC6)12	92			10	16	WM	
3.6.11	2822	(AC6)19 (AD5)28,164,217 (BD2)26 (CF4)17 (FR3)1,14 (FS3)6 (FT3)1,2 (TG5)115	92 94 97 110		R805E 820ER 822R 825E1Y 910 RBR TOP	15-39	114	HM WM SW	
3.6.11	3065	(AD5)1,161A (AC5)65 (FR3)1 (FS3)2	69 80 92 93		820IW 822CR 822R 825ER 825IO RBR	20-29 (50)	57	HM WM	
3.6.11	3149	(HA2)91 gr. 90	92	1116		16	30	HM	
3.6.11	3153	(HA2)46 -	88		825ER	12	15	WM	
3.6.11	3219	(AD5)34,87 (FS3)13 (TG5)46,73,87	65 92 94 105	1000 1128	820IR 820IP 820ER 822W	15-27	65	WM	
3.6.11	3252	(AC5)28 (TG5)73	65 92			15-32	26	WM	
3.6.11	3263	(AC5)131 (AD5)117 (TG5)113	94 110	H lug	822W 825EIP	21-14	26	WM	
3.6.11	3415	(AC5)144 (AD5)206 (CE4)86 (FQ3)8	92 94 110		822Y/P RBRIE	13-26	48	HM	
3.6.11	3498	(AD5)227,232 (FQ4)78 (TG5)4	67 110		910 RBRIE	17-30	54	HM	
3.6.11	3624	(HA2)74 gr. 218	48			13	21	HM	

Fig. no.	Type	Provenance	Fabric	Dec.	Surface treatment	Dia.	%	Man.	Comments
3.6.11	3817	(AD5)276	110	104g	825EICR	15	12	HM	
3.6.11	3824	(AD5)287 (BE2)32 (CE4)37,97	92 94 105			16-21	31	HM WM	
3.6.11	3852	(AC5)145 (AD5)256 (FP6)34 (FQ4)3,35	92 94 110	140g	825EICR 910	15-18	143	HM	
3.6.11	3879	(AD5)315	92 110			11	10	WM	
3.6.12	2111	(CE5)1 (TG5)1 98/1/4.38	34 92		822P	14-16	11	WM	
3.6.12	2911	(AC6)54 (FS3)1	69 92			50-60	16	WM SW	
3.6.12	2953	(AB4)23 (AC5)112,128	92 110		910 RBR TOP	21-56	58	HM WM	
3.6.12	3017	(AC5)13,17,99 (AD5)272 (FS3)1 (TG5)9	65 69 92 94 110		822CR 822W RBR TOP RBRI	17-27	34	HM WM	
3.6.12	3156	(HA2)52 -,68 gr. 204, 80 gr. 79	130			23	8	WM	
3.6.12	3196	(AD5)20,28	92		820ER 822R	33	35	WM	
3.6.12	3455	(FR3)12	94			34	13	WM	
3.6.12	3675	(CF3)1 (CF4)1,18,20 (TG5)46	65 92 94 110		820IP 822P/W 822W	10-17	45	HM WM	
3.6.12	3678	(TG5)46	100		820ER	44	6	WM	
3.6.12	3687	(TG5)29	-			27	-	-	
3.6.12	3890	(FQ3)42 (TG5)18	67 80		822P	17-20	18	WM	
3.6.12	4215	(TG5)102	-			27	-	-	
3.6.12	4218	(HA2)188 gr. 79 (TG5)105	69		820R	20-27	2	WM	
3.6.12	4243	TG6 86	94		822R	20	10	WM	
3.6.12	4322	(CE4)1 (CF5)4 (TG5)1	22 69 106		820IO 822P 822R	13-16	29	WM	
3.6.12	+4331	(CE4)1 (JH3)39 gr. 39	93 106	1257		16	113	WM	
3.6.12	4407	(CF3)4,41	94		822W 822W/Y	10-14	25	WM	
3.6.12	4446	(JE2)2	26		820ER	6	32	WM	
3.6.12	4495	(CF4)111 (TG5)12	92 110		825ER	16-24	11	HM	
3.6.12	4591	(CF3)49	94L		820EW	16	13	WM	
3.6.12	4768	(JD2)51 gr. 40	67			-	2	HM	

3.7. *RBRIE; Coarseware dishes, bowls and cooking pots; miscellaneous basins with everted rims*

The red-rimmed dishes and bowls (henceforth RBR, or RBRIE, 3.7.1-3.7.7) are the most common type of vessel in use in Napatan-period Kawa. Almost exclusively hand-made, the red band was usually painted separately onto the interior and exterior (rather than the pot being dipped into a thin slip, which would have resulted in the levels being the same on both sides). The vessels would have been simple to produce and inexpensive to acquire, judging by the great numbers recovered and also by their general coarseness (although some are finer). Especially the exterior but occasionally also the interior has in some instances been given a rough, random burnish (brown in colour, really the colour of the fabric itself, which is coarse and sandy) and some have a thin cream coloured slip or wash.

Similar vessels have been found at other Napatan sites (Hillat el-Arab tombs ARA 8 and 19 in particular, Sanam Abu Dom, Jebel Barkal upriver and Kerma and Aniba in lower Nubia downriver, for example) and are a continuation of the equally ubiquitous red-rimmed dishes of the New Kingdom (e.g. at Amara West, Binder *et al.* 2011, 52, fig. 29); the difference here is that they are almost all handmade. That having been said, a few rare wheel-made examples occur, such as +4783x (3.7.5) and +4780x, found in the Napatan graves (GD3)11, 38 and 98 (this latter form, with straight sides and a mould-made base, has been placed with similar beakers in section 3.10.2).

It would seem that at Kawa the RBR vessels in everyday use were handmade (for the convenience of domestic production?) while occasionally a more regular, better quality vessel would be produced. The majority are hand-made while a few are mould-made. It is not necessarily a chronological factor within the Napatan period. Apart from the bowls and dishes that have a very definite red band by the rim, there is a large number of cooking pots and basins that have a more or less prominent red band sloppily or perfunctorily applied to the top of the rim. This suggests that the application of red colour was seen as a kind of prerequisite – a nod at decoration, tradition, or even as part of a superstition – to ward off evil, or disease? The latter hypothesis is of course speculation only. The practice, in its overarching form, peters out in the early Meroitic.

The cooking pots often had thickened bases (see 3.7.10-3.7.12); the thickening is added onto the already formed pot, often in a slightly coarse fabric mix, with the thumb or finger prints visible where the extra clay was pressed onto the base (8y in Table 4.1). Several types did, however, have ordinary bases, and in many cases where only the rim could be recovered we cannot be sure. Pots used for cooking over a fire mostly have inverted rims, with only one form with vertical sides demonstrably having a thickened base (2214x, 3.7.15). From 3.7.18 onwards the forms consist of open utility ware, both hand and wheel-made.

3.7.1 Red banded rim interior and exterior (RBRIE) closed jars and a series of cooking pots, with internal or external lid seating

3471x: Bears similarities to the Greek form Chytra 187 (Lynch 2011, 283-4, fig. 146); a similar rim form, but the holes are there pierced in the flange, thought to have been made to allow condensing steam to evaporate. Late Archaic period.

+**4801x:** Height 24.6cm, width 20cm. Meroitic, by association with 4794x (3.3.3).

3.7.2 RBRIE open-mouthed jars, with everted 'S'-shaped profile

3.7.3 RBRIE large inverted to everted bowls

Including some rare wheel-made examples.

+**4655x:** Laming Macadam 1955 II, pl. XXXII.6b [2007], Napatan, a larger version of type 4167x (3.7.7).

3.7.4 RBRIE inverted bowls

Mostly handmade.

3862x: MFA Barkal B1200, Room 1203, Napatan.

3.7.5 RBRIE direct and everted handmade bowls

3705x: Aniba, Napatan burials, I.C.4.b Hembold-Doye and Seiler 2019, 138, I.C.4.b.1. Aniba grave SA 37 (E 11342); Laming Macadam 1955 II, pl. XXXII.6c [2071], Napatan.

+**4630x:** Beg. W.641(2-5? 751-664 BC) fig. A6, 23-3-460a.

3.7.6 RBRIE bowls

With both direct rims and everted 'S' forms.

2844x: Nu.61 (23, 397-362 BC) fig. 180, 18-2-373, but not with red band by rim.

3823x: Beg. W.635 (5-10? 690-568 BC) fig. A5, 23-3-449.

3841x: Hembold-Doye and Seiler 2019, 140, I.C.d.7, Aniba grave SA 36 (E 11331)

4105xa: MFA acc. no. 20.4508, Barkal, B1200, Room 1203, 750-270 BC.

4683x: Lohwasser 2010, pl. 19, Napatan pot from grave 0143 at Sanam Abu Dom.

3.7.7 RBRIE, shallow bowls and dishes

2963x: Nu.34 (23, 397-362 BC) fig. 174, 18-2-55, but no red band by rim.

3715x: Bar.12 (27.I, 322-315 BC), fig. 4, 16-2-419.

4107x: Vila 1980, fig. 21.2. Napatan.

4167x: Laming Macadam 1955 II, pl. XXXII.6b [2007], Napatan; Vila 1980, fig. 60.2, type I-1. Napatan.

4168x: Ku.53 (2, 751-716 BC) fig. 29b, 19-3-1209, form identical, but with black polish; Hembold-Doye and Seiler 2019, 139, I.C. 4.c.3, Aniba grave SA 37 (E 11340); Vila 1980, fig. 46.2, type I-1, Napatan.

3.7.8 Rims of bowls/cooking pots

2074x: Bar.1 (44, 56-43 BC) fig. 69, 16-2-288.

3.7.9 Cooking pots, complete profiles

Note that one has a ring-foot base, very unusual for this form.

3035x: Spence and Rose 2010, fig. 1.10, 18th Dynasty.

3062x: Note that only one instance, from Area Z, is a complete profile and the other examples reflect the rim only – i.e. the others do not necessarily have a ring-footed base.

4811xa: Pot C, from (FO6)157 in Building F1, Room VII.

3.7.10 Cooking pots with thickened bases

Including wheel-made variants (very rare).

2893x: The example from Area B, Building B5, Room VI, was unfired.

3.7.11 Cooking pots, continued, and decorated deep bowls

4365x: Nu.71 (8, 643-623 BC) fig. 132, 17-12-37. Decoration 1204y also in Lohwasser 2010, pl. 18, albeit covering the entire exterior of a red-rimmed bowl.

3.7.12 Cooking pots with decorated rims (1017y). Dated as Meroitic when found at Kawa by Griffith (Laming Macadam 1955 II, pl. XXXIII.5). Likely to belong to the early part of the period.

3.7.13 Cooking and storage ware with finger-impressed decoration 1012y and occasional round bosses/handles

2207x: Laming Macadam 1955 II, pl. XXXII.1g [2203], Napatan.

2210x: Orzechowska 2003, pl. 16i, Napatan.

2210x, 2238x and **4366x:** Ruffieux 2007, pl. 1.4 [17-29], in Nile clay. Dokki Gel, Napatan.

3.7.14 Thick-walled cooking ware with inverted rims

2246x: Rilly *et al.* 2020, 88-89, fig. 31 (II T 176 Cd 03), late Napatan.

3191x: Bakowska 2010, fig. 4.39, late and post Meroitic periods.

4307x: Boulet 2016, fig. 2.d, second half of the Third Intermediate Period.

3.7.15 Coarseware bowls with straight sides

2304x: Nu.8 (10, 593-568 BC) fig. 54, 18-3-207, rim a little more everted; Beg.W.456A (undated) fig. M.1, 23-2-322A.

4377x: Rilly *et al.* 2020, 88-89, fig. 31 (II T 278 Cd 01). Late Napatan.

3.7.16 Vertical sided large bowls

2256x: The examples with a large diameter (up to 50cm) are most likely bread ovens, cf. 3.9.11.

3.7.17 Various vessels with angular rims and open-mouthed coarsewares

The upper six forms are of open-mouthed bowls, while the

lower six belong to more restricted jar types. A miscellaneous collection of relatively rare forms at Kawa.

3.7.18 Variations on beaded rims, with vertical sides

2449x: Mohamed Ahmed 1992, fig. 27 III A9, mid 6th to late 5th centuries BC.

3.7.19 Beaded or flanged rims, everted deep bowls or basin forms

2284x: Beg.S.2 (28, 315-297 BC) fig. 10, 21-2-477b.

3438x: Bar.1 (44, 56-43 BC) fig. 69, 16-2-286 HRW.

3.7.20 Miscellaneous dishes and bowls, various rim forms, including lid-seating

2468x: Nu.40 (10, 593-568 BC) fig. 86, 18-1-279, red ware; Nu.51 (24, 362-342 BC) fig. 125, 21-3-216c.

3619x: Rilly *et al.* 2020, 87-88, fig. 30 II 220-150 Cs 04. Early Napatan.

3.7.21 Dishes with beaded and plain rims

2041x: Nu.47 (16, 503-478 BC) fig. 130, 18-1-163.

2175x: Nu.61 (23, 397-362 BC) fig. 180, 18-2-354; Nu.17 (22, 398-397 BC) fig. 169, 17-3-381; Nu.32 (19? 453-423 BC) fig. 157, 18-2-406, 18-3-984; Nu.12 (21, 418-398 BC) fig. 163, 17-3-388 red ware; Nu.33 (21, 418-398 BC) fig. 167, 18-3-995; Nu.31 (19, 453-423 BC) fig. 153, 18-2-675; Mohamed Ahmed 1992, fig. 19 I D6g, mid 6th to early 5th centuries BC.

2228x: Nu.75 (?), 653-643 BC) fig. 24, 18-2-312 red ware.

2507x: Ku.T4 (A, 860-840 BC) fig. 3a, 19-3-410, polished red ware.

2634x: Nu.41 (8, 643-623 BC) fig. 31, 17-3-595, red ware.

3.7.22 Coarseware bowls with rolled-over and plain rims; basket impression 200y

2439x and **2760x:** Bar.11 (27, 322-315 BC) fig. 3, 16-2-411.

3673x: Nu.9 (11, 568-553 BC) fig. 92, 17-1-232, fine red ware. Inverted form with rolled-over rim, see also Nu.9 fig. 91, 16-12-125, red ware.

4758x: Spence and Rose 2010, 2-3, fig. 1.10, early 18th Dynasty.

3.7.23 Open bowls and basins with plain rim.

3.7.24 Miscellaneous basins with different types of rim

4582x: Beg.W.415 (45-55, 43 BC-AD 115) fig. C.14, 23-2-119 rim a little different. Also Bakowska 2010, fig. 5.58, with the rim slightly less square, with 3rd century BC parallels.

4821x: Appears to belong to the same ware type as 4444x (4.10).

3.7.25 Everted basin forms with squared-off rims

2899x: cf. Barkal pottery IV², Bar.8 (32, 263-248 BC), fig. 130, 16-2-378.

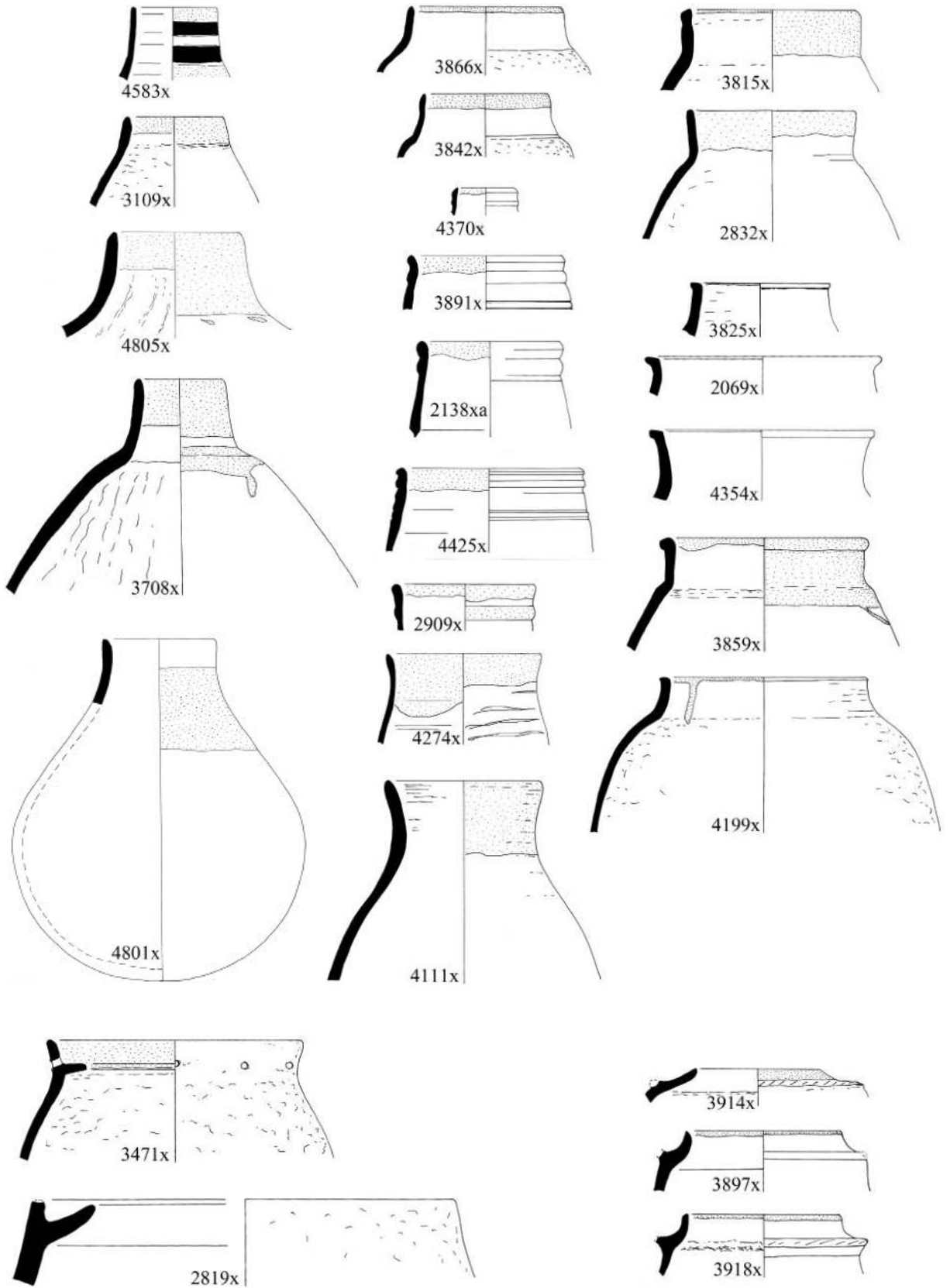

Figure 3.7.1. RBRIE jars (scale 1:4).

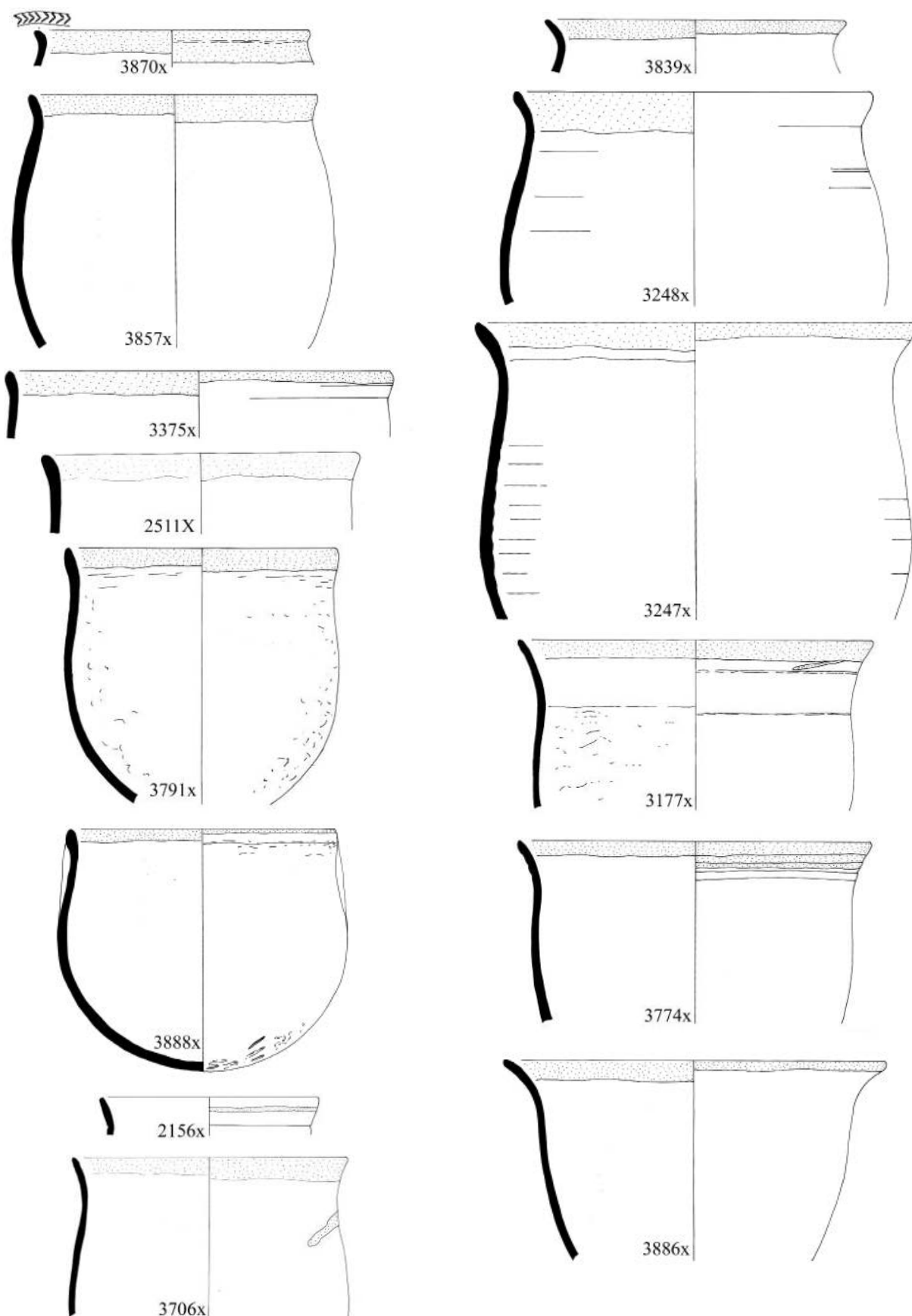

Figure 3.7.2. RBRIE deep bowl with 'S'-shaped profile (scale 1:4).

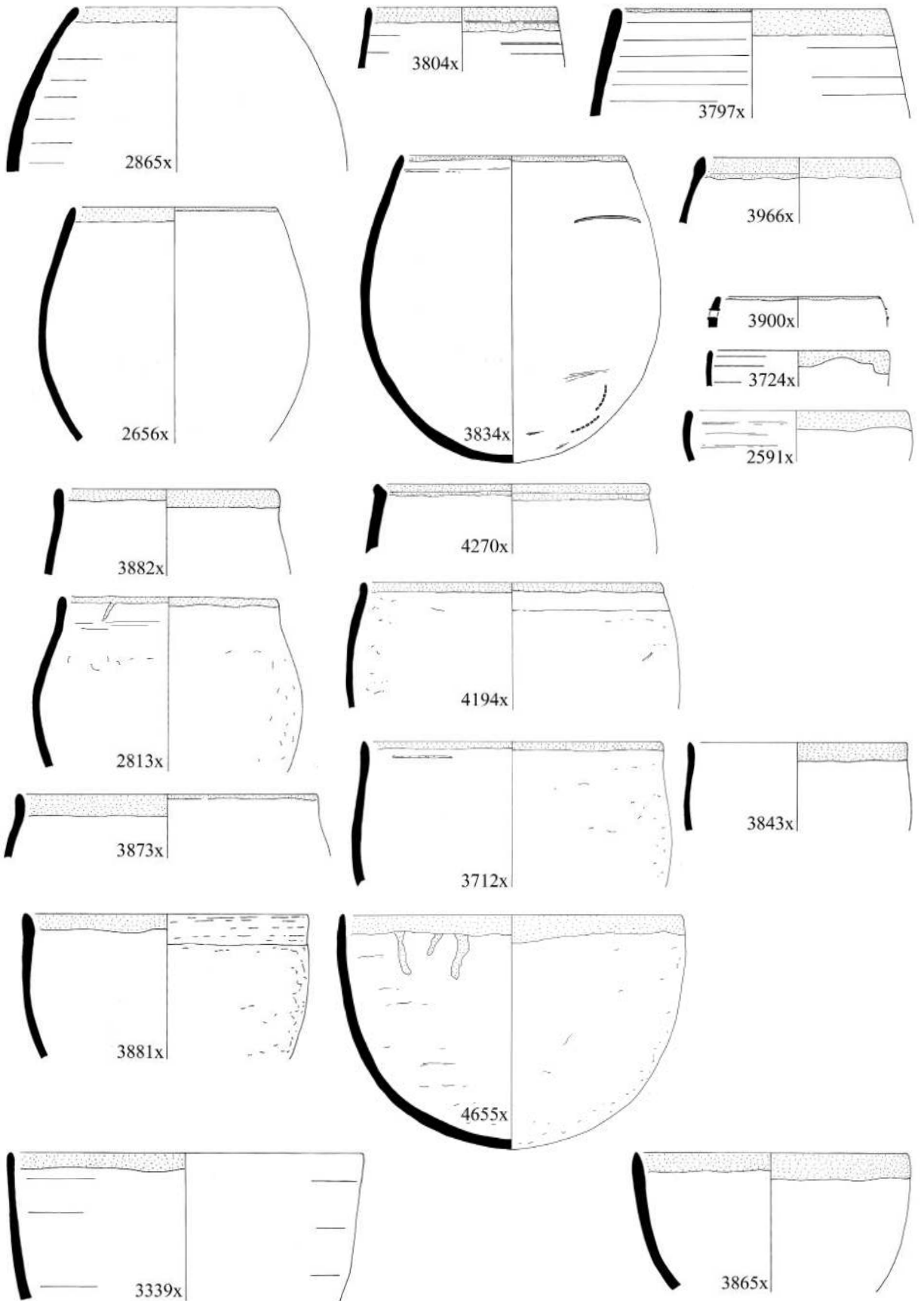

Figure 3.7.3. RBRIE miscellaneous bowls (scale 1:4).

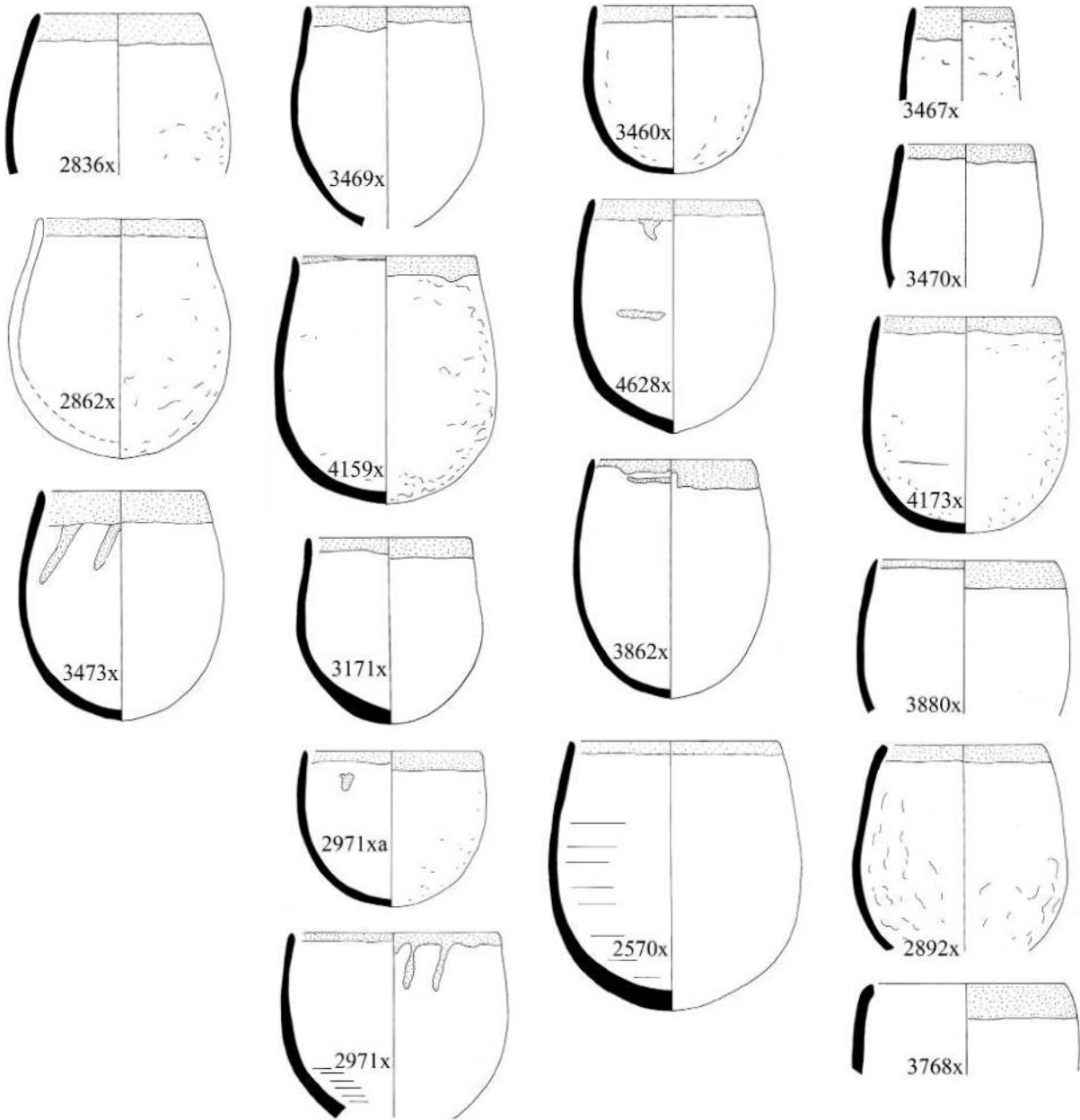

Figure 3.7.4. RBRIE bowls and beakers with inverted rims (scale 1:4).

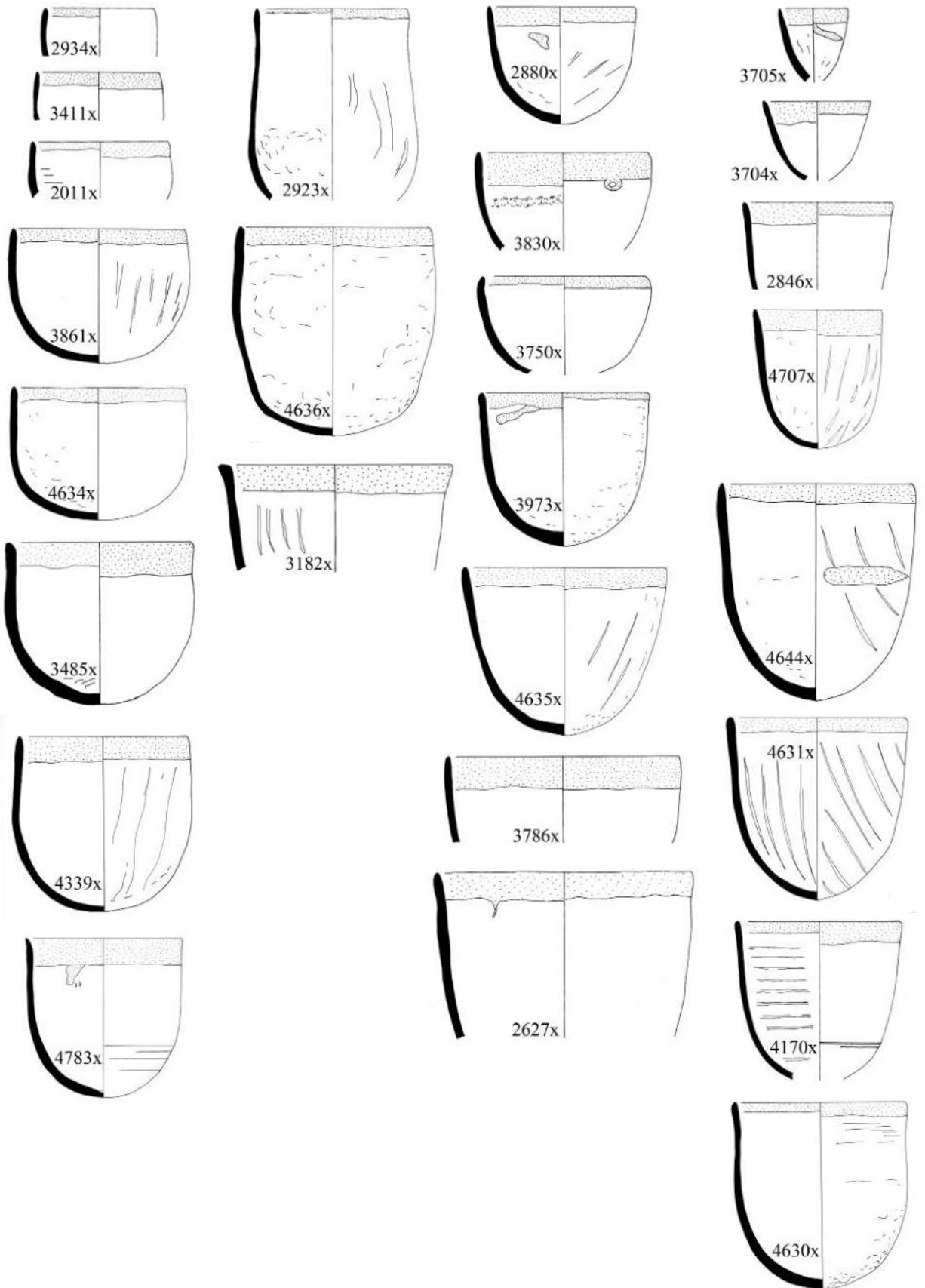

Figure 3.7.5. RBRIE bowls and beakers with vertical sides (scale 1:4).



Figure 3.7.6. RBRIE bowls and beakers with 'S'-shaped profile (scale 1:4).

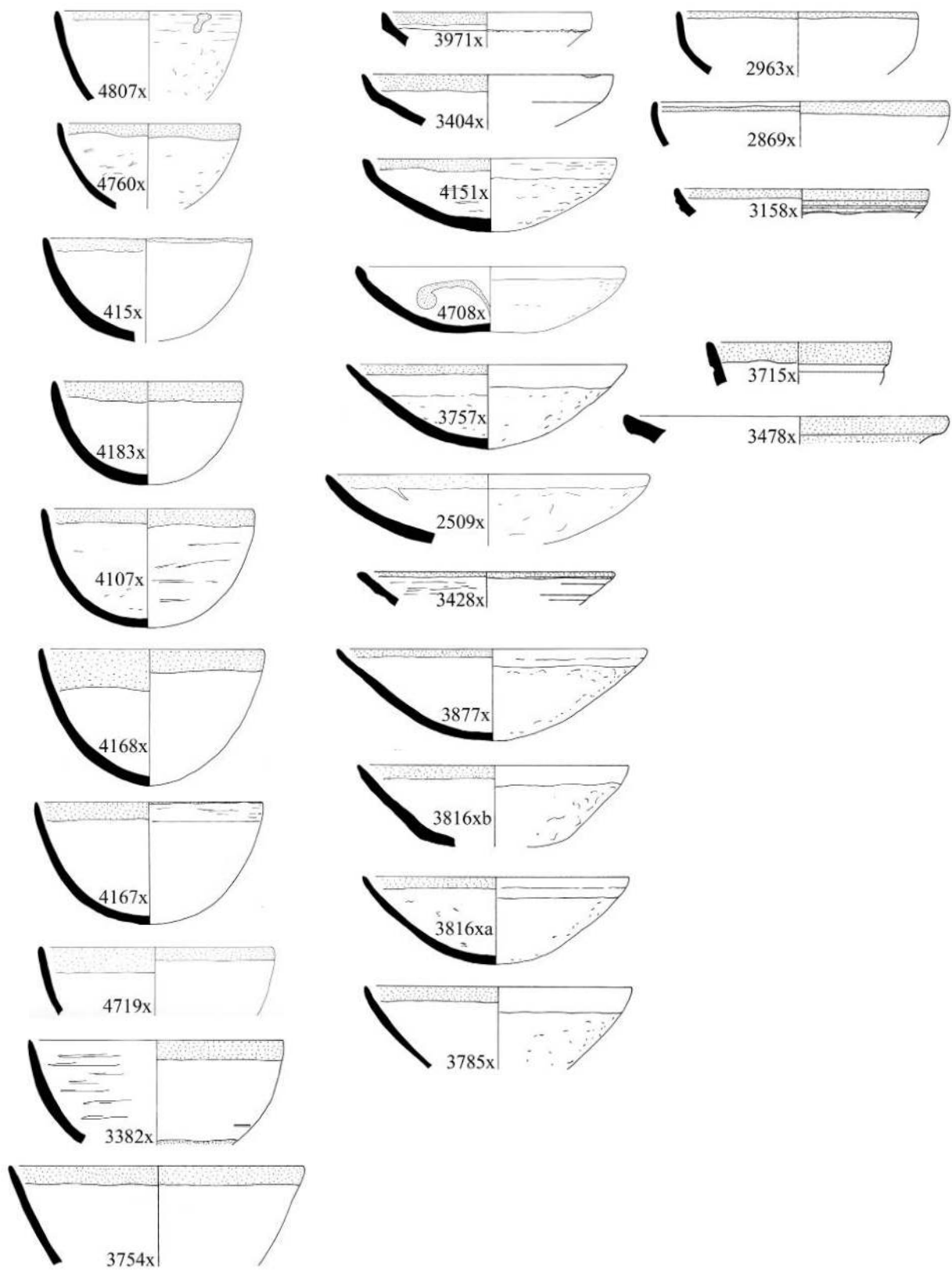

Figure 3.7.7. RBRIE bowls with everted sides and dishes (scale 1:4).

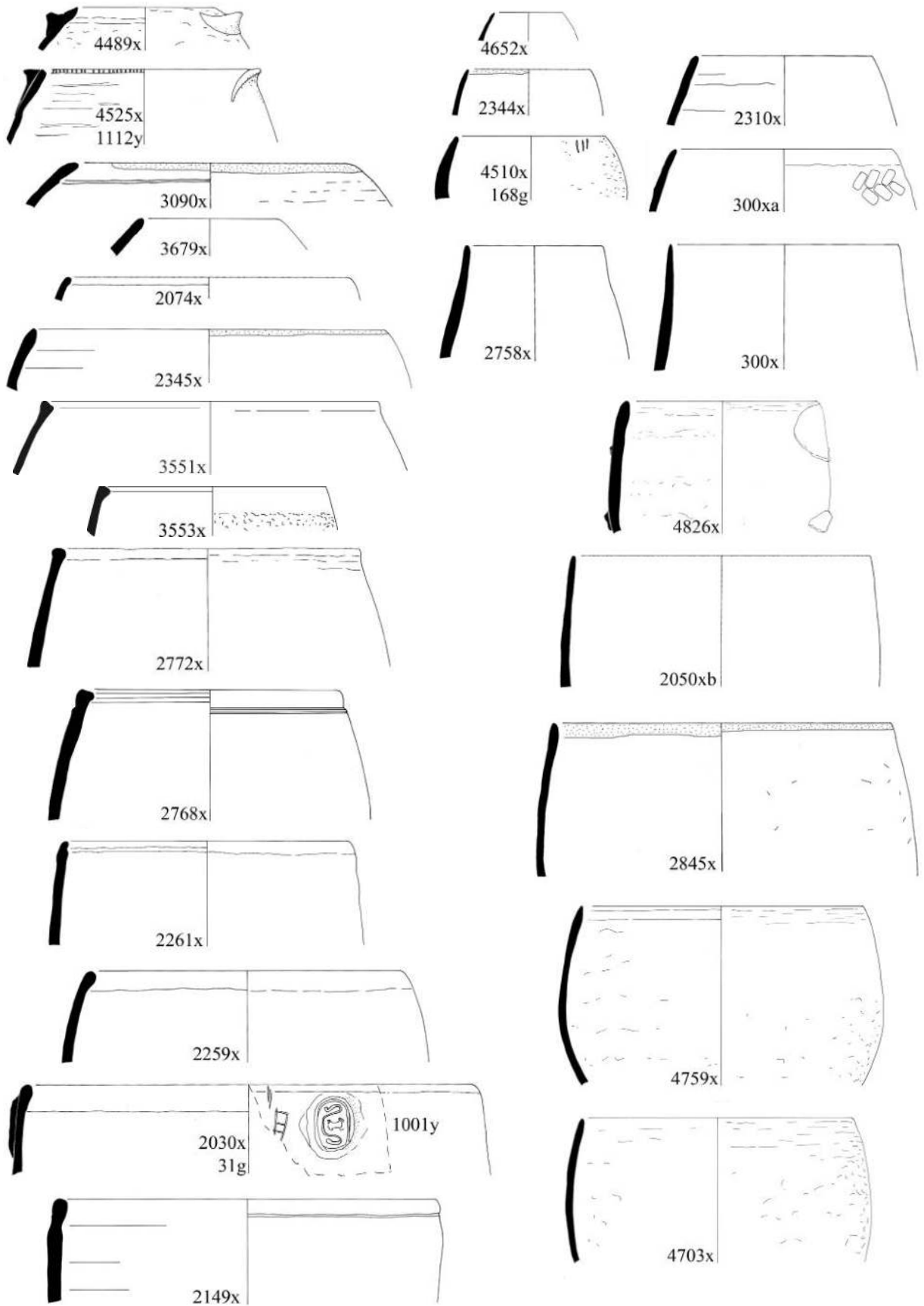

Figure 3.7.8. Rims of coarseware bowls/cooking pots (scale 1:4).

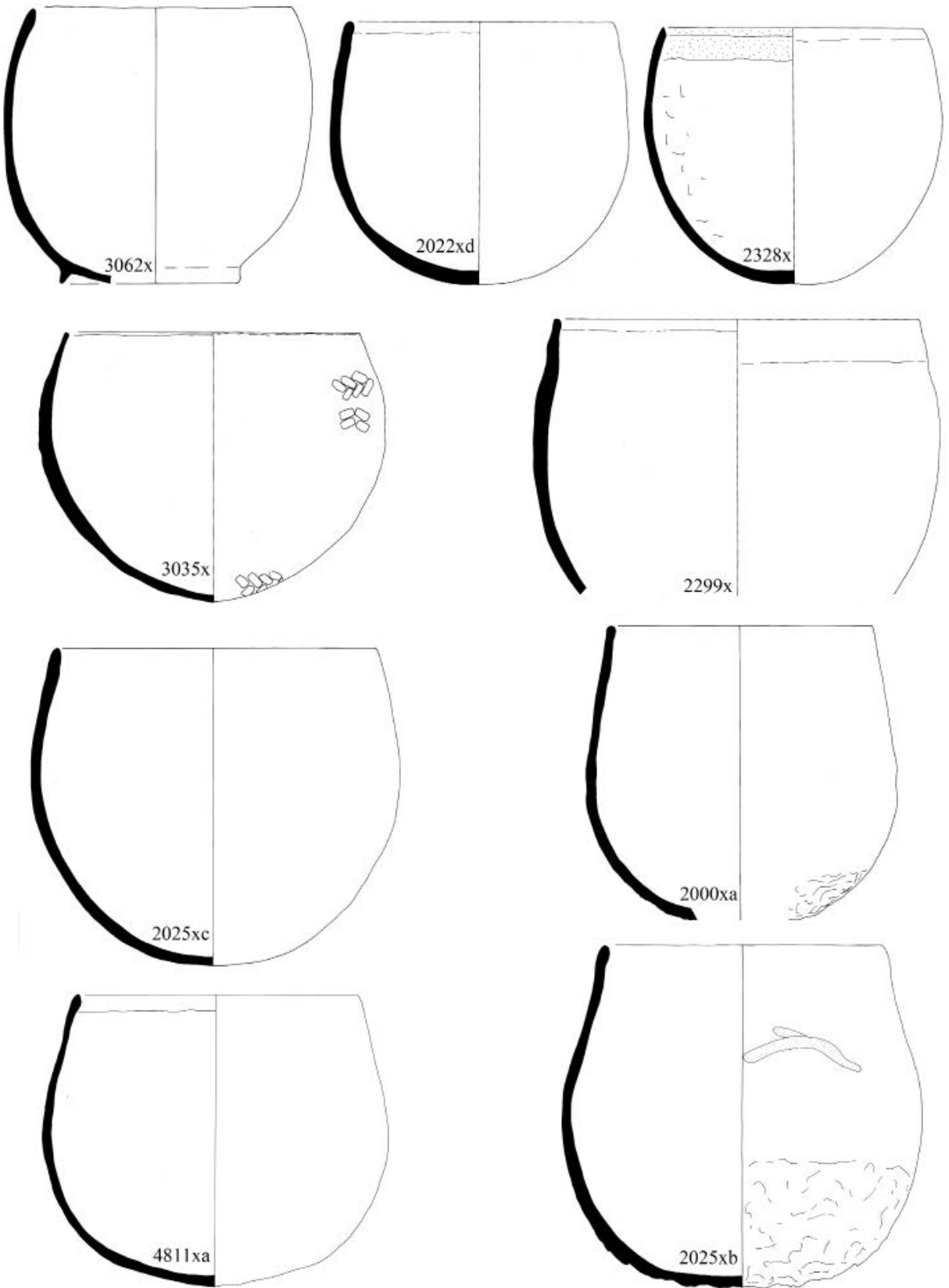

Figure 3.7.9. Cooking pots, complete profiles (scale 1:4).

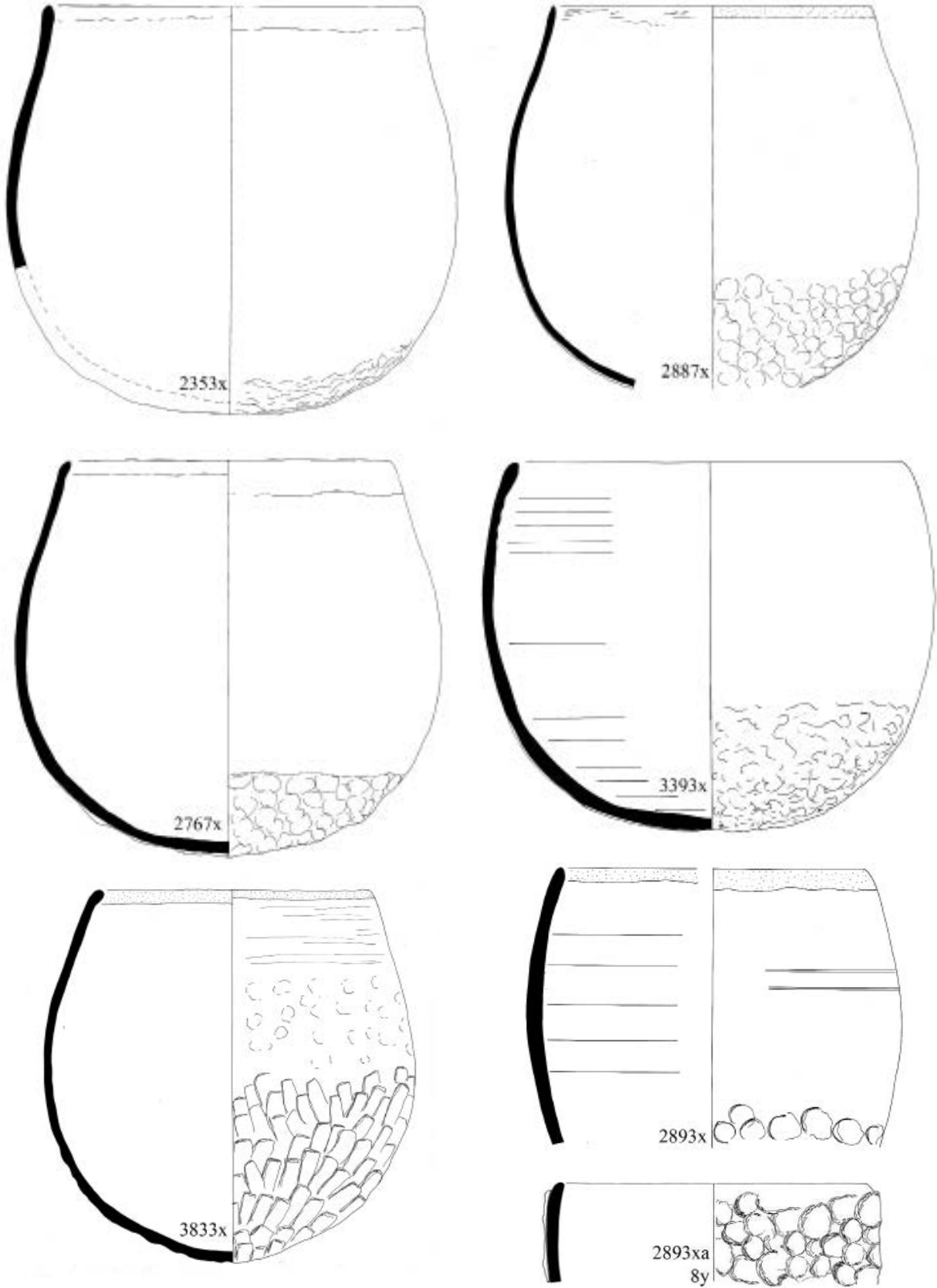

Figure 3.7.10. Cooking pots with thickened bases, including wheel-made variants (scale 1:4).

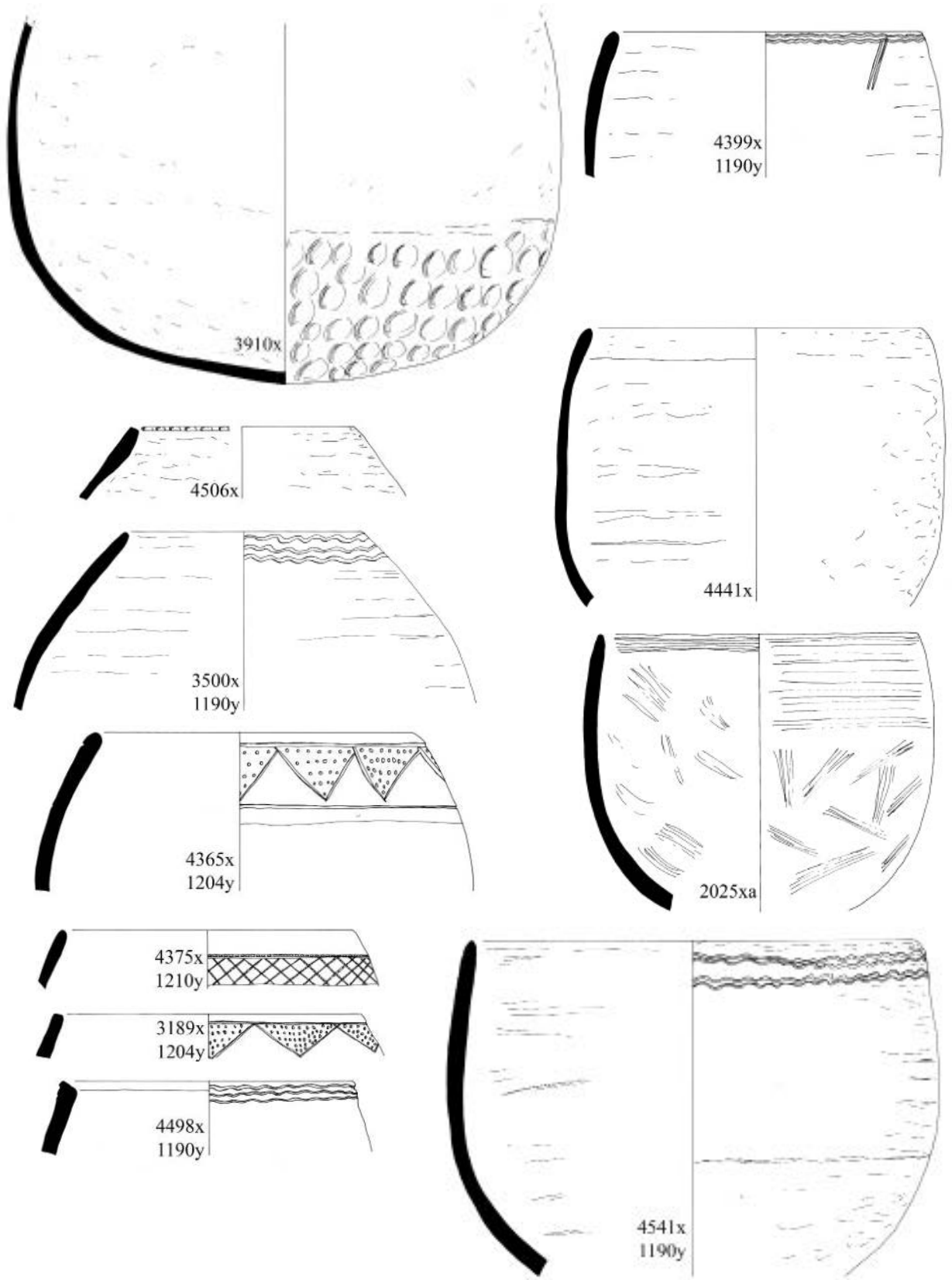

Figure 3.7.11. Cooking pots (continued) and decorated deep bowls (scale 1:4).

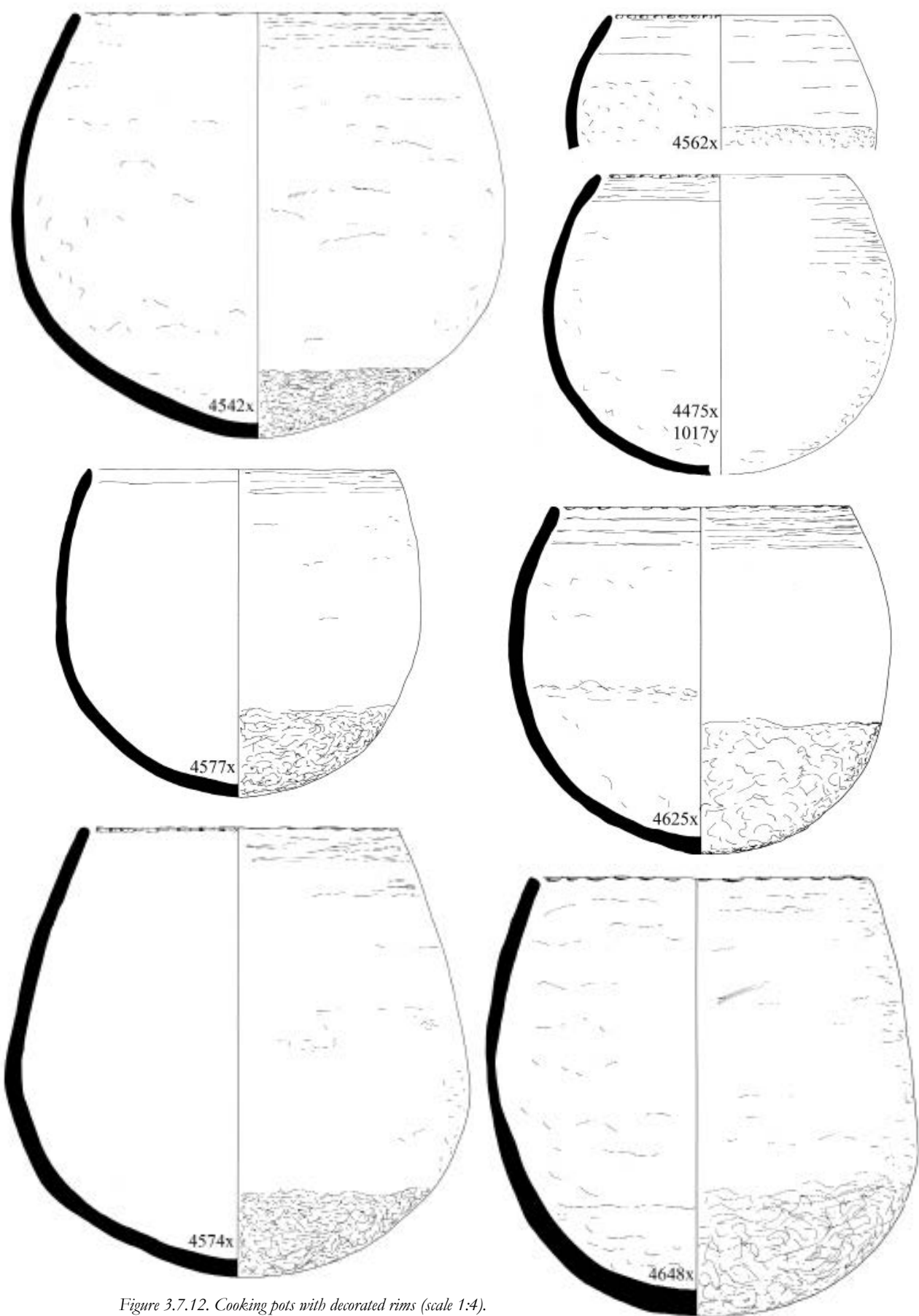

Figure 3.7.12. Cooking pots with decorated rims (scale 1:4).

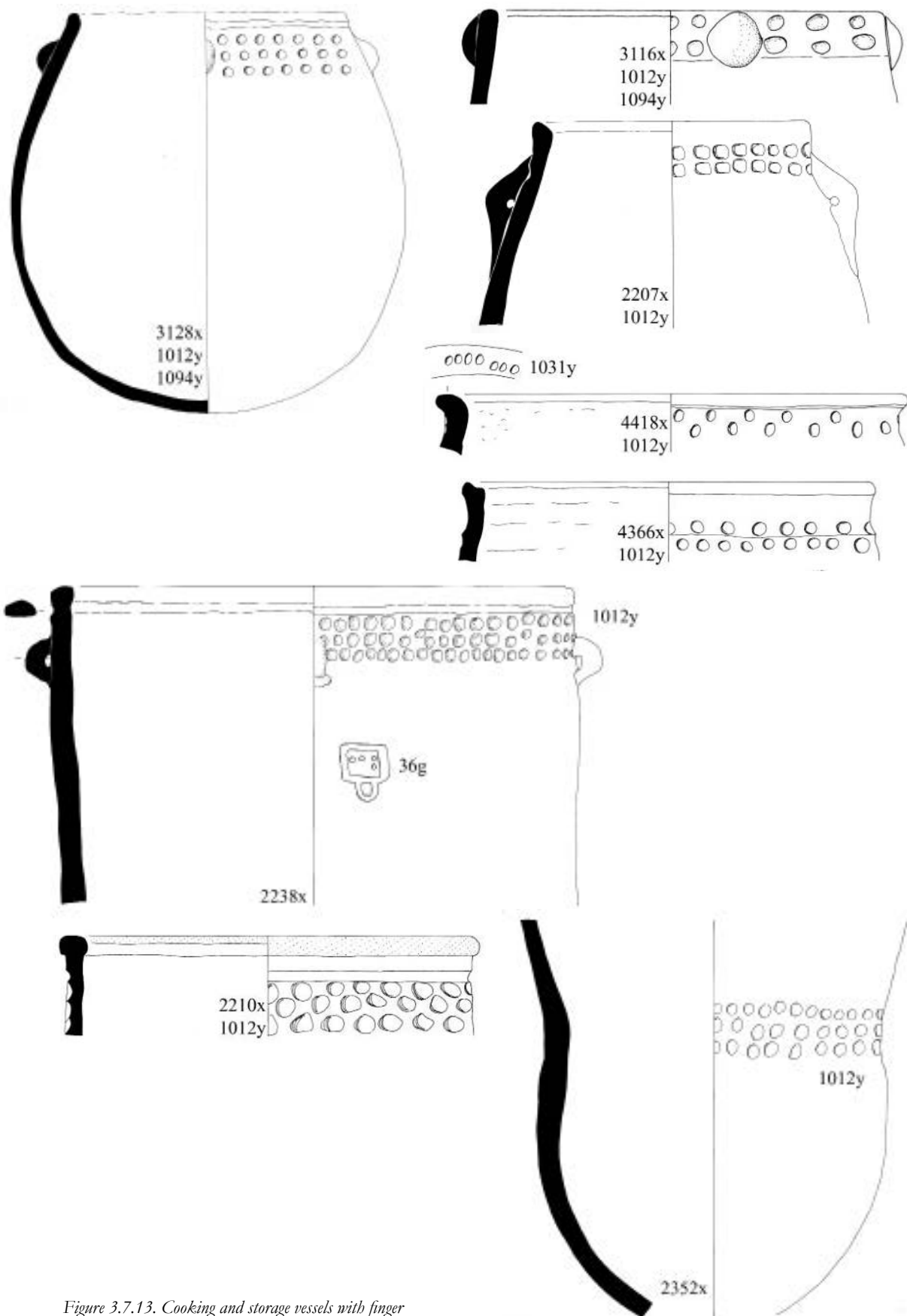

Figure 3.7.13. Cooking and storage vessels with finger impressed decoration 1012y (scale 1:4).

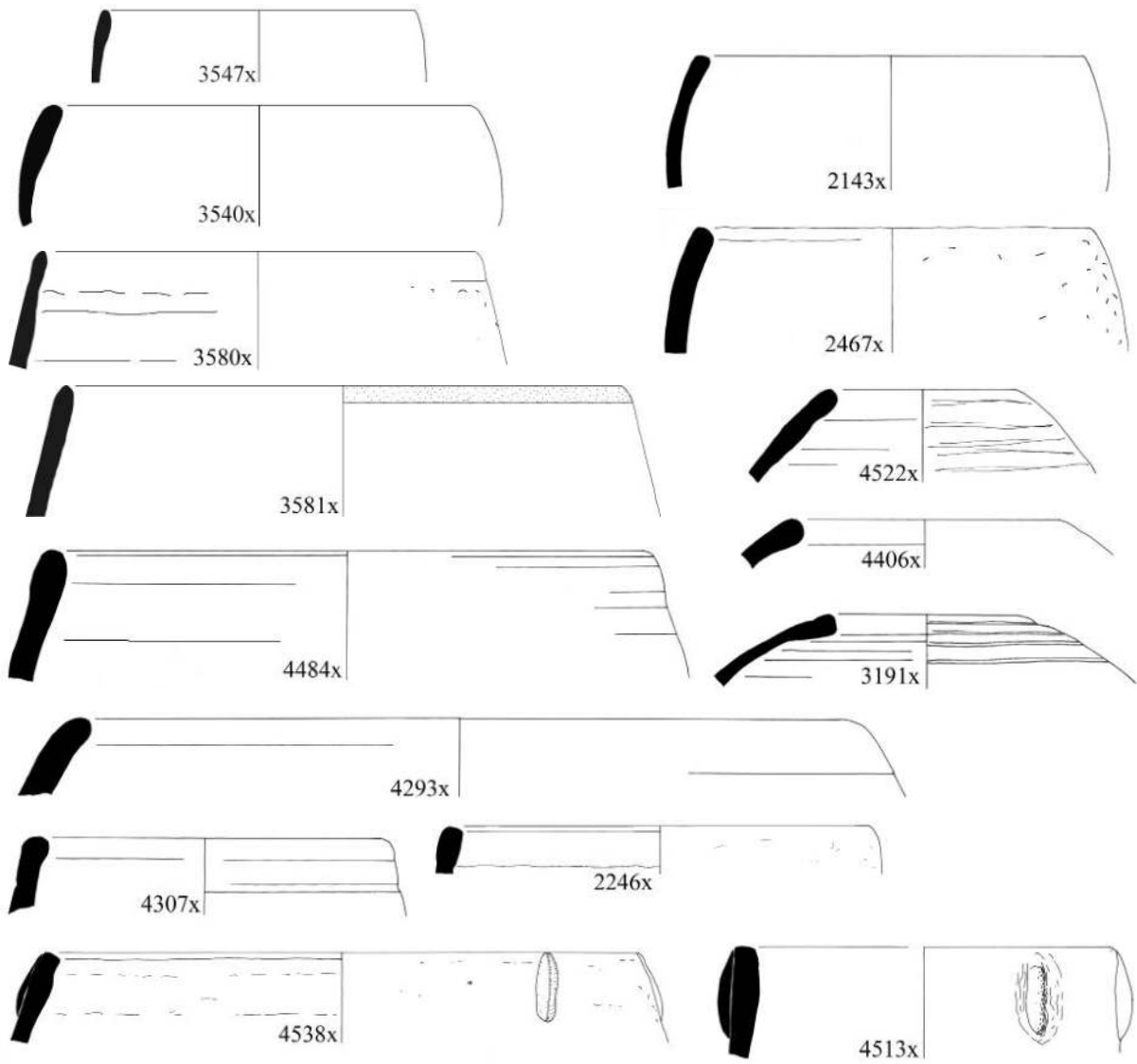

Figure 3.7.14. Thick-walled cooking pots with inverted rims (scale 1:4).

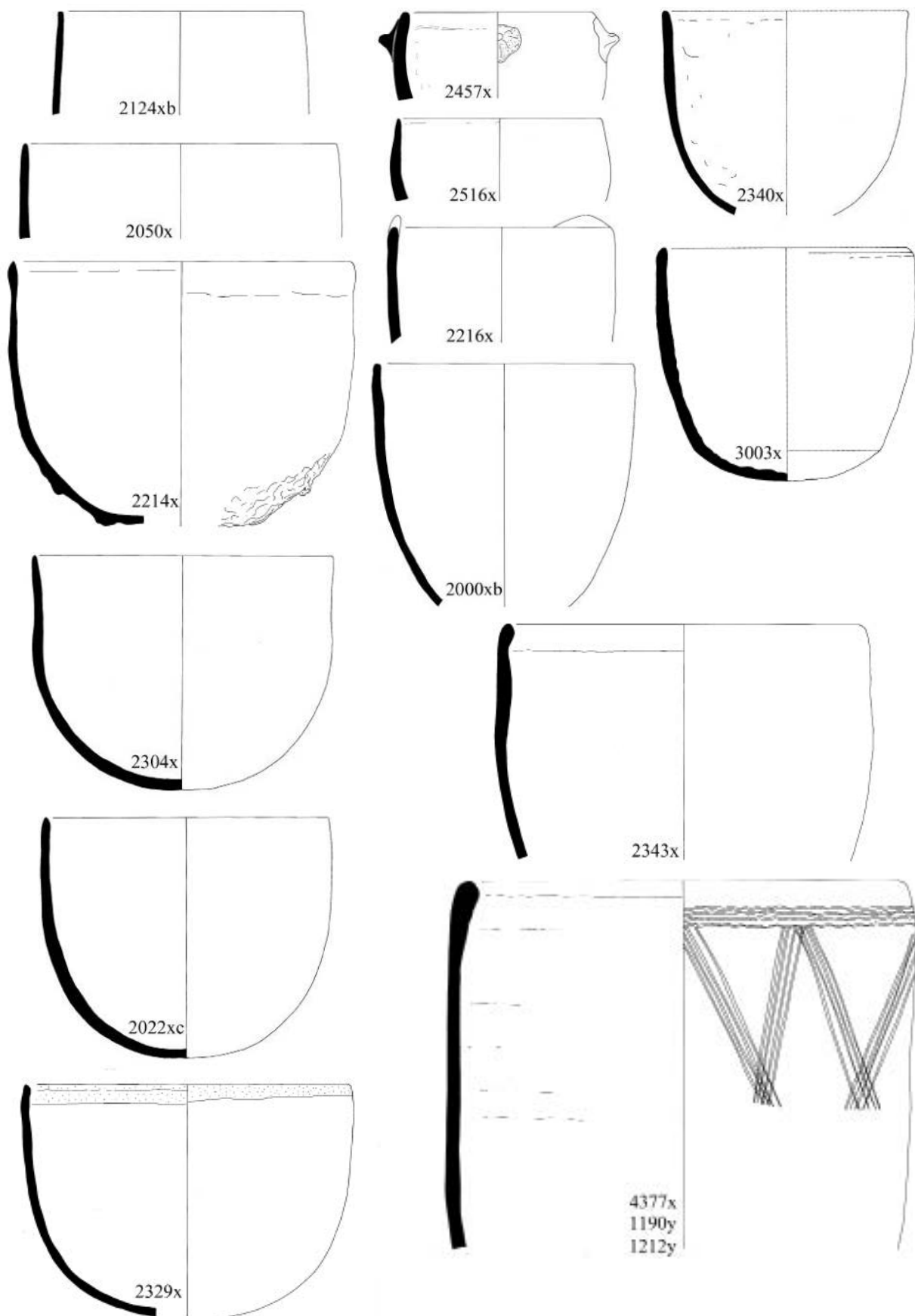

Figure 3.7.15. Coarsenare bowls with straight sides (scale 1:4).

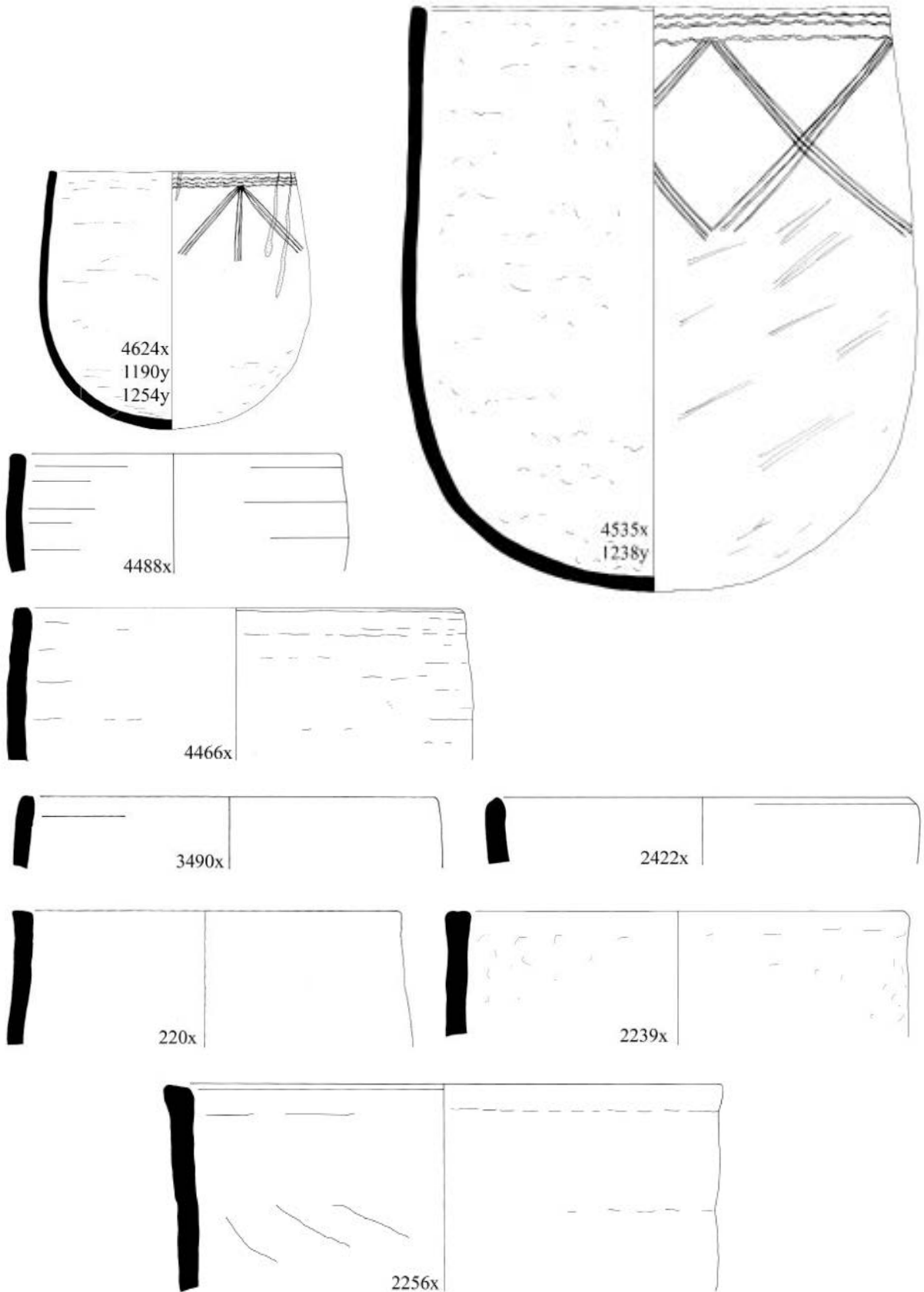

Figure 3.7.16. Vertical-sided large bowls (scale 1:4).

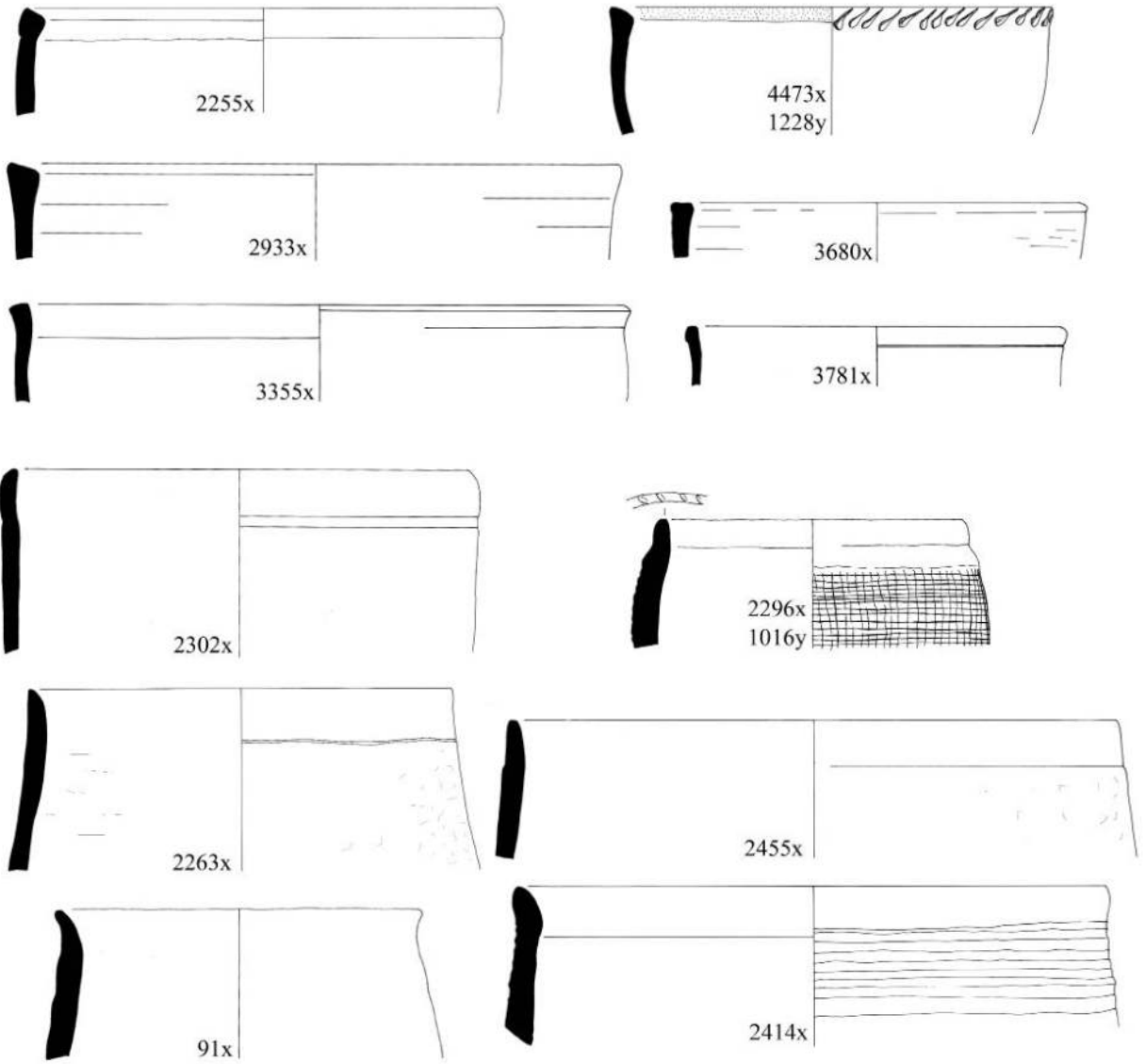

Figure 3.7.17. Various vessels with angular rims and open-mouthed coarsewares (scale 1:4).

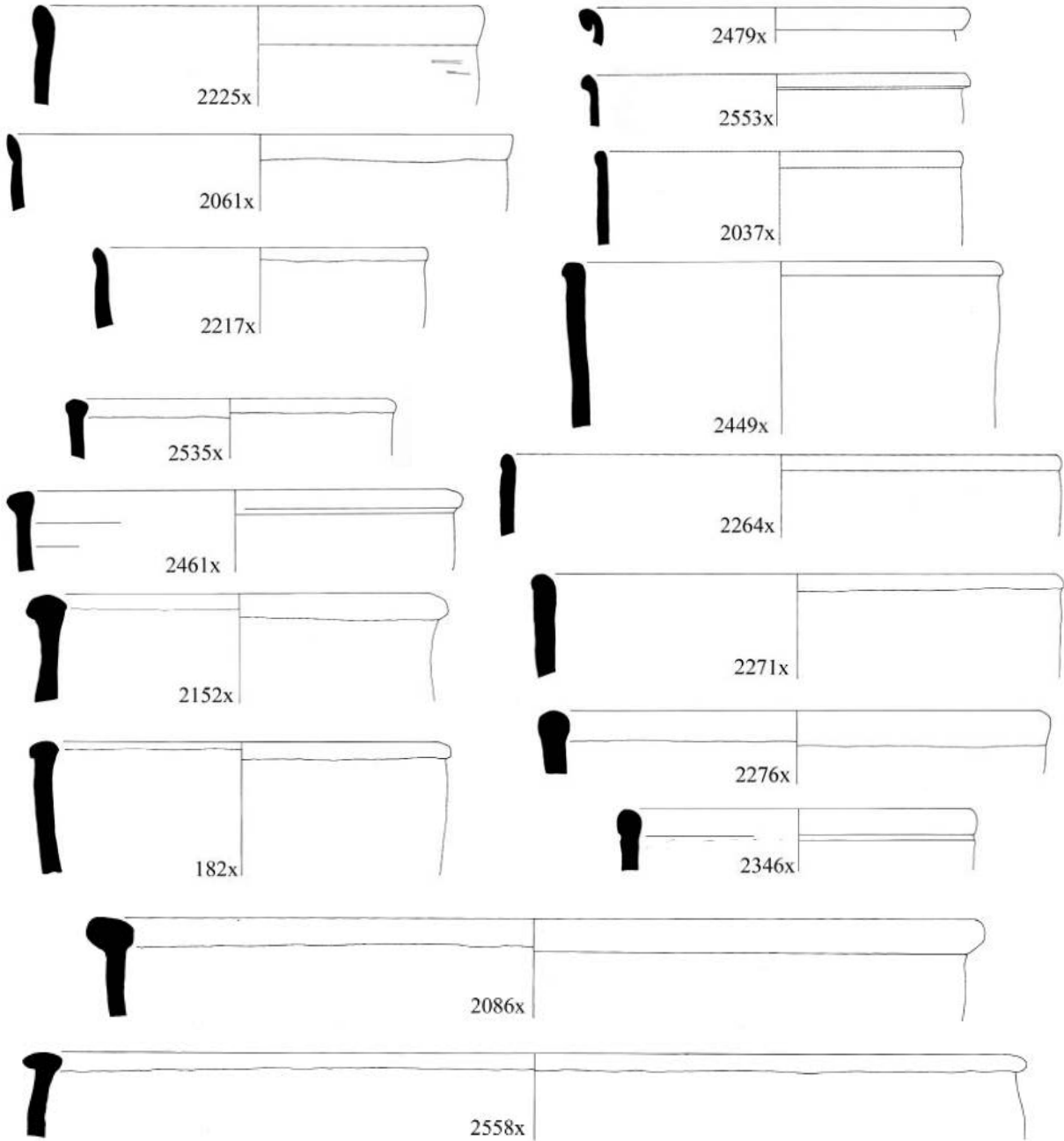

Figure 3.7.18. Variations on beaded rims, vertical sides (scale 1:4).

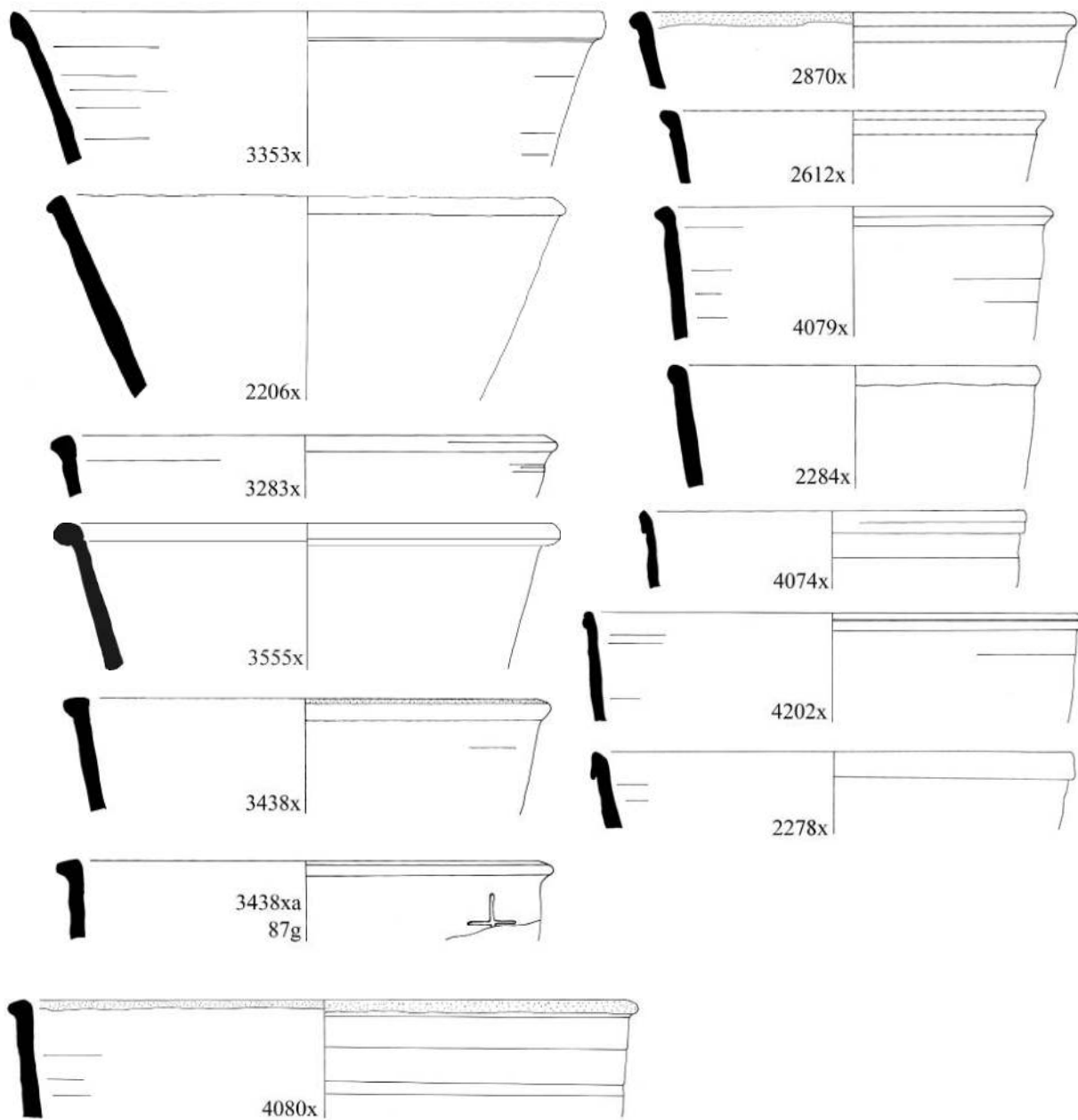

Figure 3.7.19. Beaded or flanged rims, everted deep bowls or basin forms (scale 1:4).

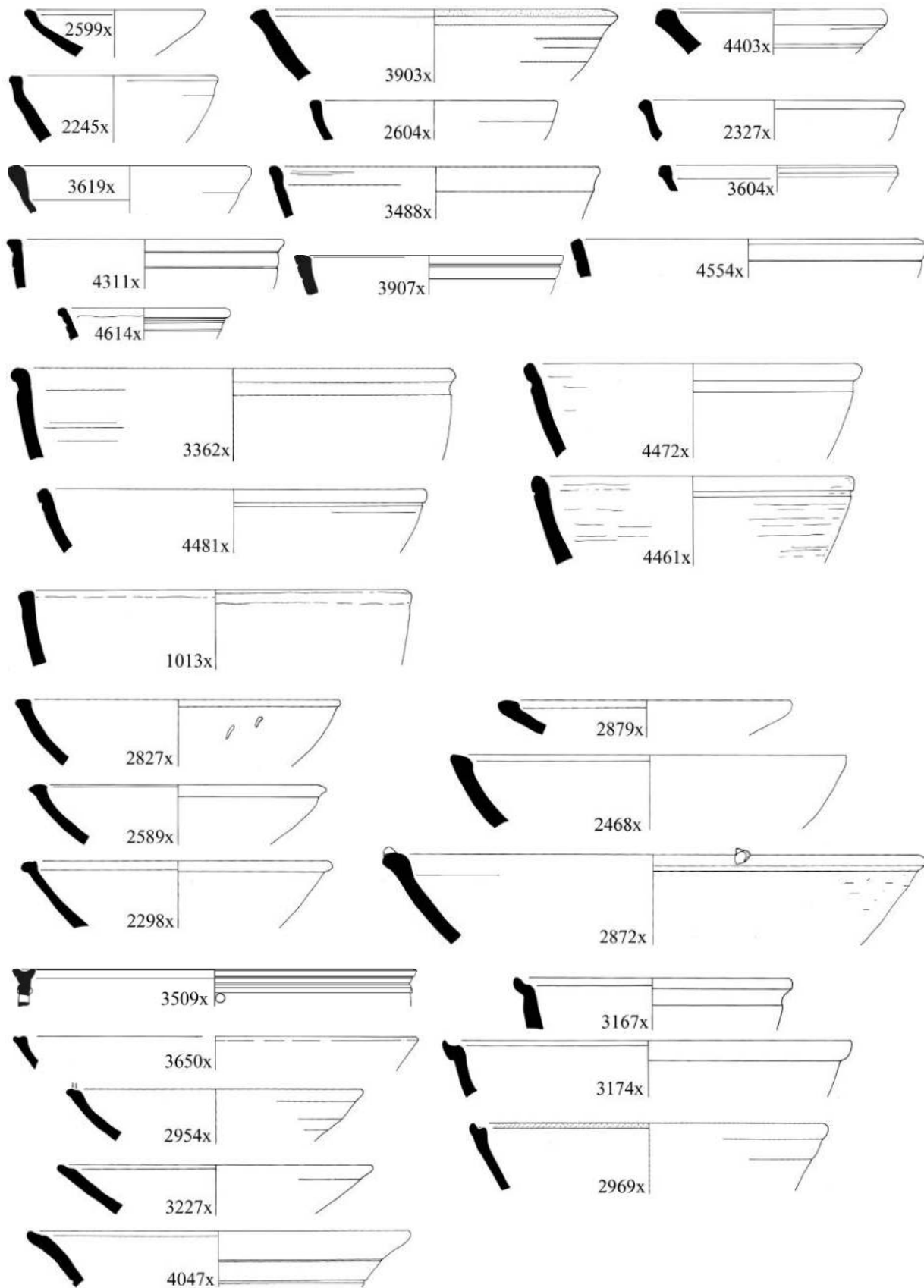

Figure 3.7.20. Miscellaneous dishes and bowls, various rim forms, including lid-seating (scale 1:4).

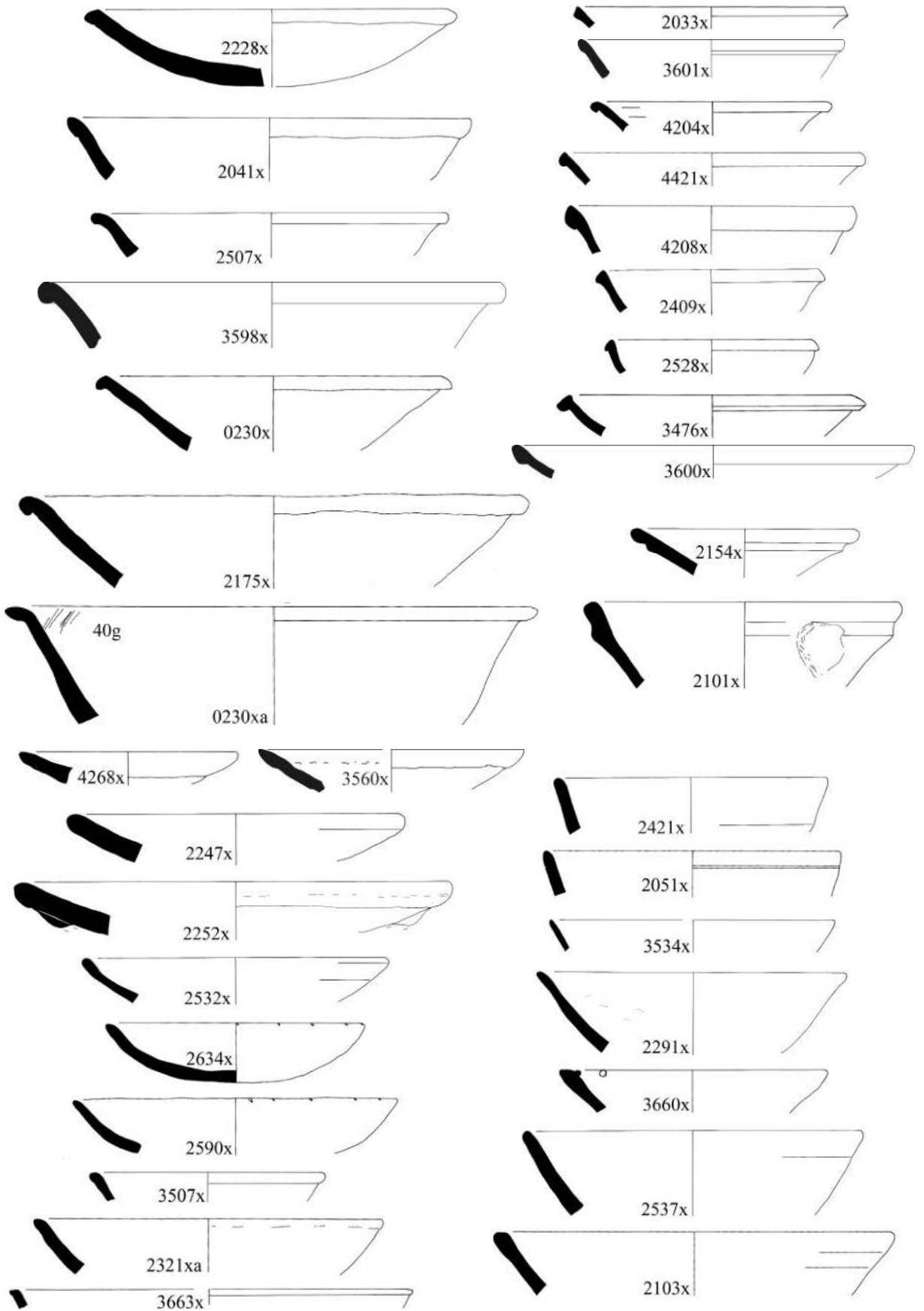

Figure 3.7.21. Dishes with beaded and plain rims (scale 1:4).

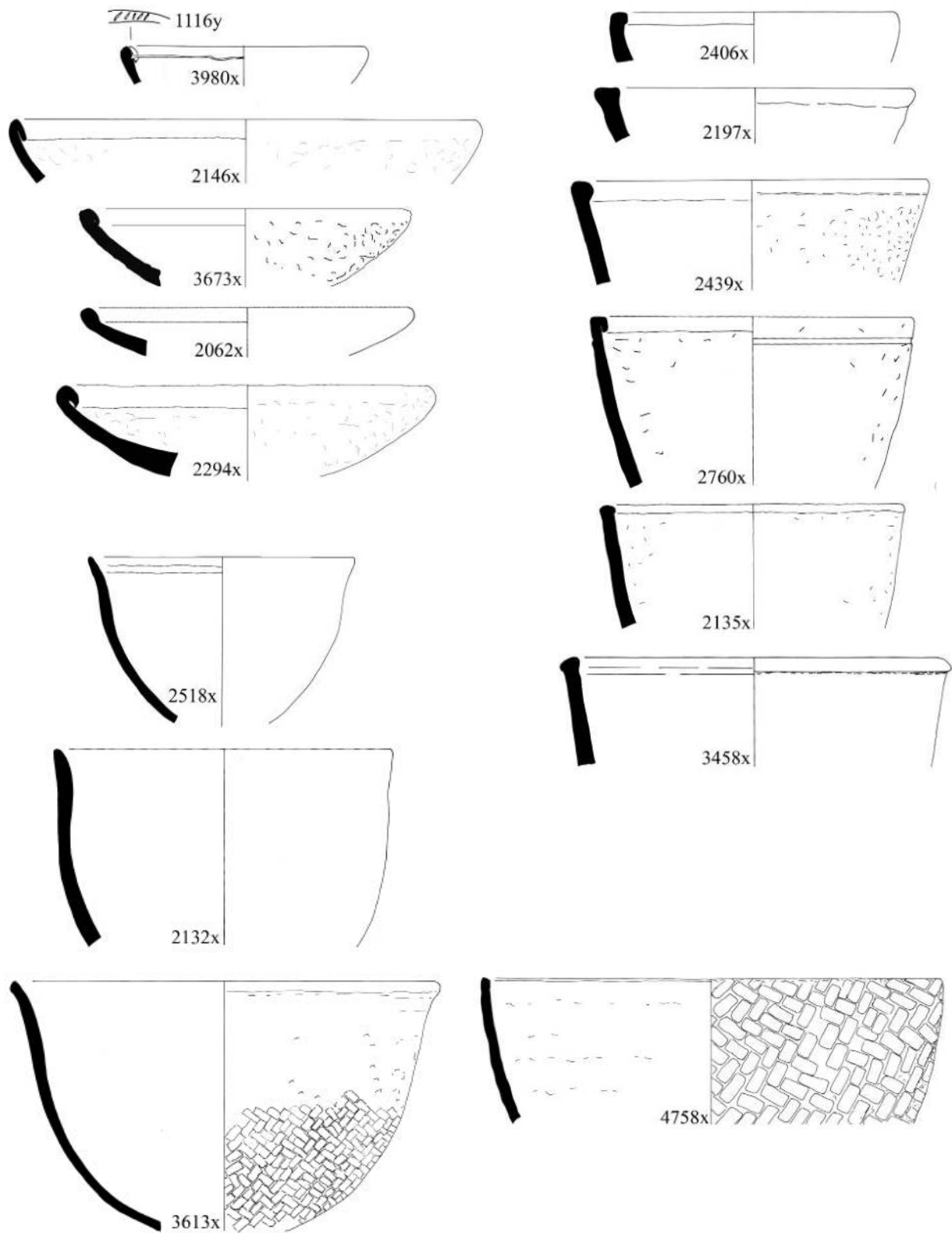

Figure 3.7.22. Coarsenare bowls with rolled-over and plain rims; basket impression 200y (scale 1:4).

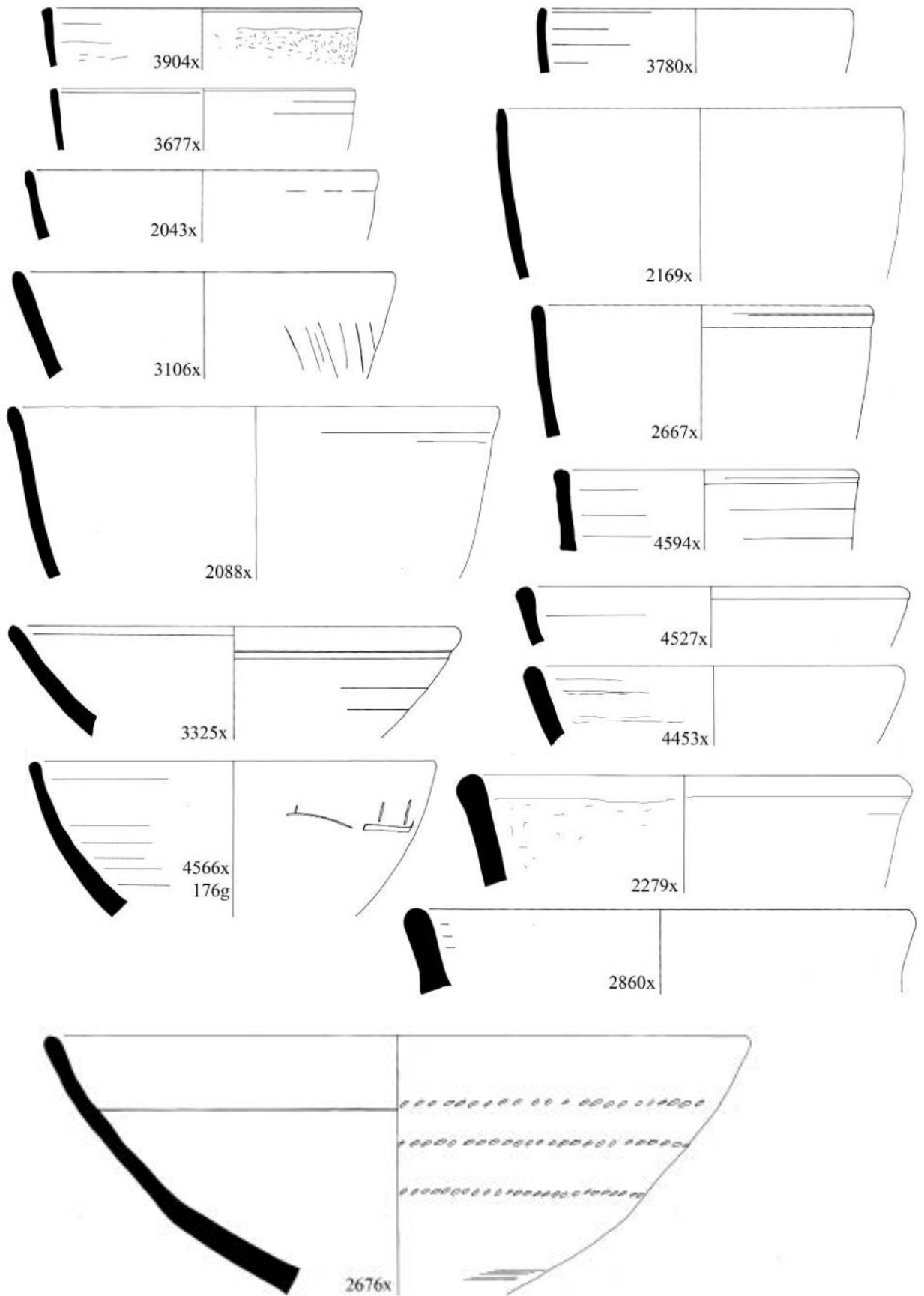

Figure 3.7.23. Large open bowls and basins (scale 1:4).

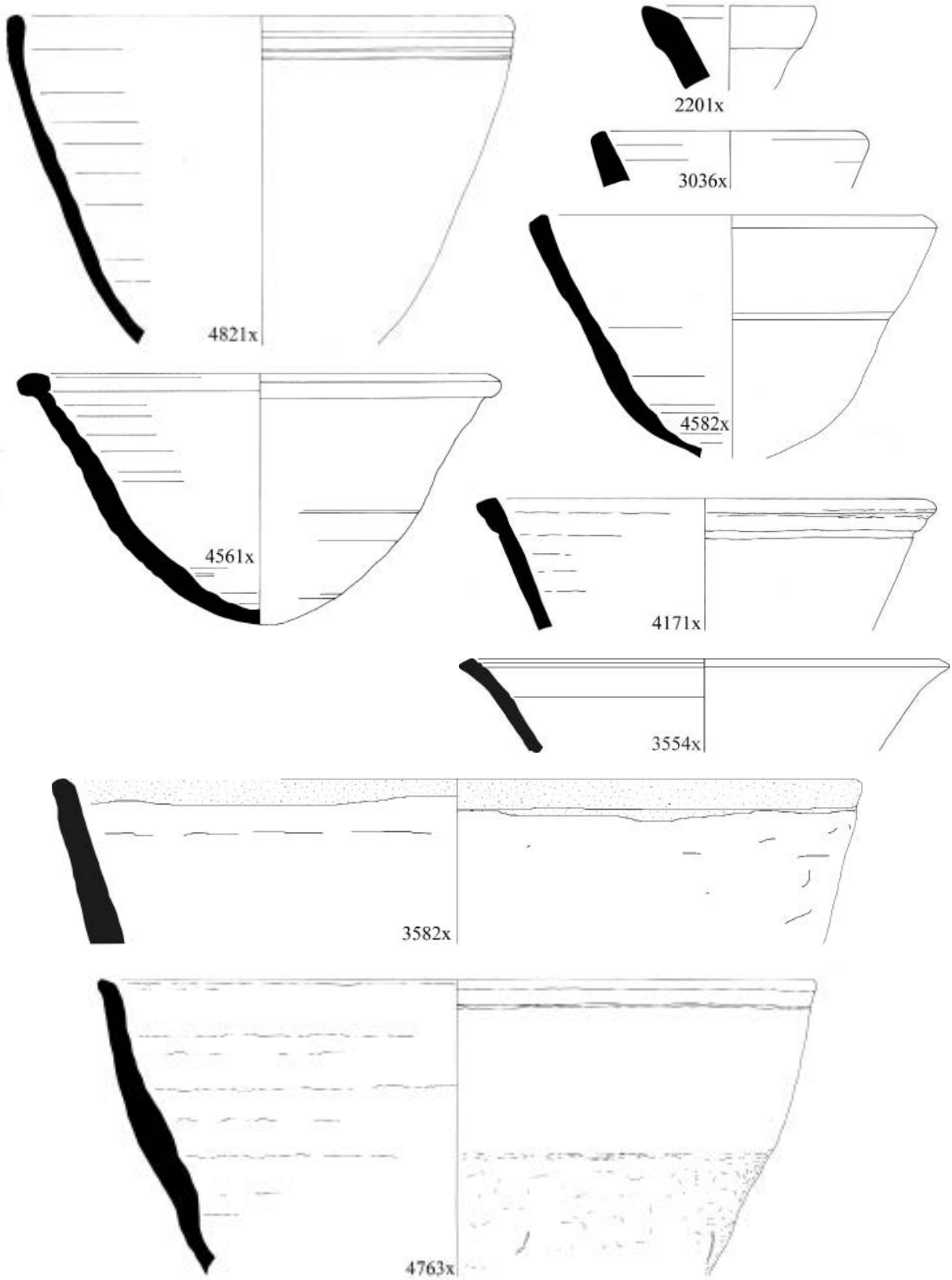

Figure 3.7.24. Miscellaneous basins (scale 1:4).

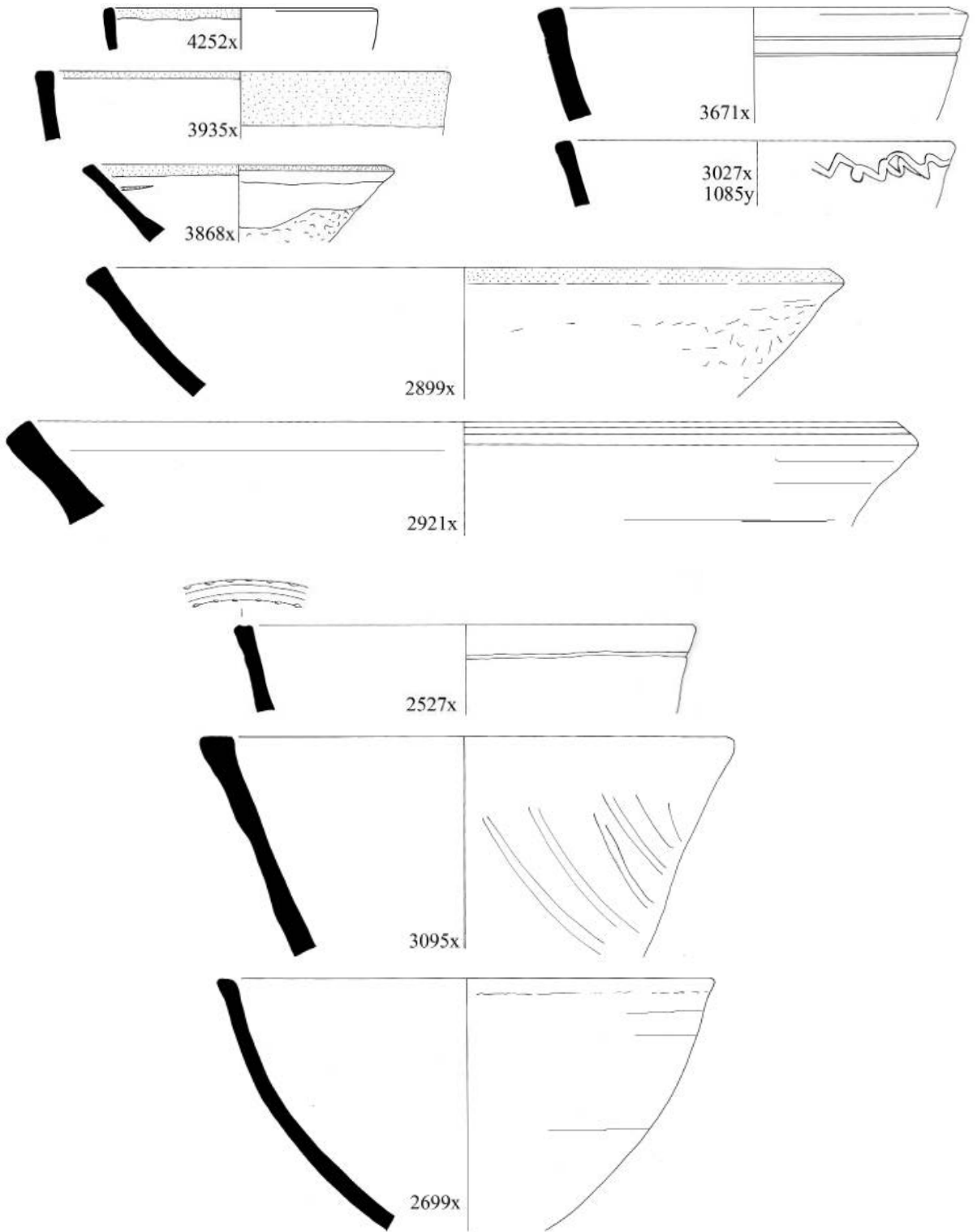

Figure 3.7.25. Everted basin forms with squared-off rims (scale 1:4).

4801x
3.7.1



4655x
3.7.3



4783x
3.7.5



3861x
3.7.5



Plate 3.7.1. A selection of RBRIE jars, bowls and cups.

4630x
3.7.5



3469x & 3862x 3.7.4

4630x 3.7.5



3858x
3.7.6



4630x

3845x

3700x

3.7.4-3.7.6



3862x

3836x

3473x



2767x
3.7.10



4811xa
3.7.9



2000xa
3.7.9

*Plate 3.7.2. Miscellaneous cooking pots,
note thickening of the base in some.*



3833x
3.7.10



2353x
3.7.10



4574x
3.7.12



3128x
3.7.13

3003x
3.7.15



4561x
3.7.24



4535x
3.7.16

Plate 3.7.3. A wheel-made cooking pot, a basin and a medium-sized storage jar.

TABLE 3.7. RBRIE; COARSEWARE DISHES, BOWLS AND COOKING POTS; MISCELLANEOUS BASINS WITH EVERTED RIMS.

Fig. no.	Type	Provenance	Fabric	Dec.	Surface treatment	Dia.	%	Man.	Comments
3.7.1	2069	(AD6)5 (BD2)28 (BF2)40 (FP6)9 (FQ3)9	69 92 92F 110		RBR 910	10-26	53	HM WM	
3.7.1	2138a	(AB4)10	65		820ER	10	47	WM	
3.7.1	2819	(AB5)59	67		820IW	-	-	WM	
3.7.1	2832	(AC6)27 (AD5)161A,256,287 (BD2)71 (FO7)69 (FP7)1 (FQ3)8 (FQ4)7 (FR3)14 (TG5)73,74	67 92 94 110		822CR 825EIR 910 RBRIE	9-24	92	HM	
3.7.1	2909	(AB4)27	65		820EIR RBRIE	10	12	WM	
3.7.1	3109	(AD5)250 (CF4)18 (FQ4)37 (JF1)6 (ZH5)37	15 92 94 95 110		804E 810E 820ER 822CR RBRIE	7-20	68	HM	
3.7.1	3471	(FR3)0	110	871?	RBR	16-18	38	HM	or holes to secure lid?
3.7.1	3708	(AC5)144 (AD5)227,276,293 (FP6)81,169 (FQ4)79	92 110		RBR TOP RBRIE	6-15	87	HM	
3.7.1	3815	(AD5)269 (FO7)68 (FP7)82 (TG5)91	92 94 110		825EIR RBRIE	10-20	42	HM	
3.7.1	3825	(AC5)112 (FP6)111,128	92 110		825EIR RBR	10-14	53	HM	
3.7.1	3842	(AD5)258 (FO6)125 (FP6)92 (FP7)35 (FQ4)7,8,59	92 110		910 RBRIE	9-12	34	HM	
3.7.1	3859	(AD5)283	110		RBRE	14	10	HM	
3.7.1	3866	(AD5)296 (FO6)109 (FP6)1 (FP7)12 (FQ4)24 (JF2)15 gr. 14	30 92 110		RBRIE	8-22	87	HM	
3.7.1	3891	(FR4)2	94		825ER	12	23	WM	
3.7.1	3897	(FP6)14 (FQ3)58 (FQ4)2	92 110		RBR RBRIE	11-15	37	HM	pre-firing hole 7mm
3.7.1	3914	(FQ4)7	110		RBRE	9	10	HM	
3.7.1	3918	(FQ4)2,21,64	92 102 110		822CR RBRIE	11-14	14	HM	
3.7.1	4111	(FO6)19	94		820ER BAND	11	45	HM	
3.7.1	4199	(BE4)13 (FP6)9	1 110		910 RBR	15-18	68	HM	
3.7.1	4274	(TG5)77	92		V820ER	11	53	WM	
3.7.1	4354	(CE4)1 (FP7)2	67F 110			12-16	36	HM WM	oil soaked
3.7.1	4370	(CF5)1	92F		822R	4	10	WM	
3.7.1	4425	(TG5)1,6	65 93		825EP	13	20	WM	
3.7.1	4583	(CF4)100	115		H825ER 832EBR	6	18	WM	
3.7.1	+4801	(GD3)66 gr. 63	110		820EO RBR	8.5	100	HM	
3.7.1	4805	(GD3)1,141 gr. 138	92C 110		RBRIE	9	25	HM	
3.7.2	2156	(BF3)9 (FQ4)26	13 110		822CR	16-17	18	HM WM	
3.7.2	2511	(AB5)22 (AB6)1 (AC5)17 (AC6)14,22,23 (AD5)1,134,167,289 (AD6)1 (BD2)70 (CF4)69 (FQ4)88	69 92 92F 93 94 110		820ER 820EW 910 RBRIE	15-30	205	HM WM	
3.7.2	3177	(AD5)164,227,236 (FP6)172 (FP7)1,32 (FR3)1,22 (FR4)1	92 92C 110		910 RBRIE	15-28	125	HM	

Fig. no.	Type	Provenance	Fabric	Dec.	Surface treatment	Dia.	%	Man.	Comments
3.7.2	3247	(AC5)28,34,37,45 (AD5)136 (FR3)0 (TG5)4	94 110		825EBL 910 RBRIE	20-32	186	HM WM SW	(AC5) 999
3.7.2	3248	(AC5)28,34,37,38	80 89 92 93		820EW RBRIE	21-26	78	WM	
3.7.2	3375	(AC5)39 (FP7)11,32	69 92 110		RBRIE	13-28	29	HM WM SW	
3.7.2	3706	(AD5)227	110		825EIR RBRIE	21	14	HM	
3.7.2	3774	(AD5)217,246,258 (FO6)37,58,71,92 (FO7)73 (FP6)1,2,3,54,57 (FP7)26,48 (FQ3)60	92 92C 110		822R 910 RBRIE	13-28	378	HM	
3.7.2	3791	(AD5)272,273 (FO7)31,44 (FP6)9 (FP7)1,5,12,17,34,52,123 (FR4)13 (FZ2)1	69 92 110		910 RBRIE RBRI	13-28	1218	HM	
3.7.2	3839	(AC5)144,145,174 (AD5)295,310 (FO6)157	92 110		822CR RBRIE	16-24	39	HM	
3.7.2	3857	(AD5)256 (FP6)57,135 (FP7)5,17	92 110		R805I 825ECR RBRIE	21-24	213	HM	
3.7.2	3870	(AD5)293 (CF4)75	110	1143	910 RBRIE	20-23	15	HM	
3.7.2	3886	(AC5)144 (FO6)37 (FO7)52 (FP7)23,52	110		825EICR RBRIE	18-28	92	HM	
3.7.2	3888	(AC5)163	92		RBRIE	20	85	HM	
3.7.3	2591	(AB4)20,31 (AB5)68,91/ 94,230 (AC6)36 (FT3)22	12 65 69 92		820ER 820EW 825EIW RBRI RBRIE	9-20	71	HM WM	
3.7.3	2656	(AB4)7 (AC5)79,85,89,92,112,117,126,129,134,150 (AD5)28,162,167,168,214,219, 236,246,276,311 (AD6)13,16 (FN6)1,6,9 (FO6)15,59,61,125,61,89,98,148,180 (FO7)25,56 (FP6)5,54,57,60,65, 72,92,105,118,125,137,143,154,156,169,172,179,182,183 (FP7)1,5,10, 12,18,21,22,27,28,32,35,38,53,72,82,102,105,117,123,136,137,141,149 ,151,152,159,181 (FQ3)20,43,44,58 (FQ4)2,7,23,37,59 (FR3)0,1, 2,12 (FR4)1,7,9,13 (FS3)1,4 (FT3)1,3,4 (FZ1)1,2,9 (FZ2)1 (GD3)12 gr. 11 141 gr. 138 (TG5)6,137	11 58 69 92 92C 92F 110 110L	97g 192g 1112 851	V802 820EY/R 822CR 825ECR 825EIBR 910 RBRE RBRIE NRBRIE	11-30	3111	HM WM	oil soaked
3.7.3	2813	(AB5)59,279 (AB6)13,16 (AC5)102,105,116,117,126,128,131,144,145 (AC6)14,20,22,23,30,31,36,37,40,54,59,84 (AD5)128,157,164,214,215, 217,219,246,258,276,282,293,294,298,315,319 (AD6)5,11,13,16 (FQ3)8 (FQ4)7,37,59 (FR3)4,12,14 (FT3)7	69 92 94 110		820FCR 822CR 825EICR 910 NR- BRIE RBRIE RBRI	13-24	4022	HM	
3.7.3	2865	(AD5)186,315 (BD3)32 (FN6)3 (FP7)111,137,191 (FQ4)8,37 (FS3)16 (ZH5)37	92 94 110		820ER NRBRIE RBRIE	12-34	295	HM WM	
3.7.3	3339	(AC5)82,112,114,116,126,128,144,145,172 (AD5)136,283,287 (FO6)2 (FP6)135,149 (FQ4)113 (FQ/R4)2 (FR4)1 (FZ1)8 (FZ2)1,22	69 92 94 110	200	R805I 805E 820ECR 822CR 910 NRBRIE RBRIE	14-28	415	HM	
3.7.3	3712	(AD5)224	110		RBRIE	20	27	HM	
3.7.3	3724	(AD5)214,242,277,287 (FO6)15 (FP6)66 (FQ3)26,53 (FQ4)98 (FZ1)7 (TG5)89	92 110		910 RBRIE	12-19	144	HM WM	
3.7.3	3797	(AD5)260	69		RBRIE	20	12	WM	

Fig. no.	Type	Provenance	Fabric	Dec.	Surface treatment	Dia.	%	Man.	Comments
3.7.3	3804	(AD5)272 (FO6)129 (FP7)127	92 92F 110		RBRIE RBR TOP	14-19	38	HM	
3.7.3	3834	(AC5)131 (FO6)157,160 (FO7)69,76,77,86,89,96 (FP6)9,128,161 (FZ2)22 (GD3)12 gr. 11	92 92C 92F 110 110L		910 RBRE NRBRIE RBRIE	15-23	2926	HM	
3.7.3	3843	(AD5)273,281 (FO6)19,34,37,60,179 (FO7)23,65,69,85,96 (FP6)8,31,37,61,97,109,128,131,133,135,136,155 (FP7)21,26,32,35,123 (FQ3)22,26,42,43,52,58,59 (FQ4)9,27,33,37,44,49,98,104 (FZ1)8,10,24,25,27 (FZ2)1,8,22 (GD3)141 gr. 138 (TG5)119,120 (AC5)145 (AD5)296 (FO6)129 (FP7)53 (AD5)312 (FP6)31,72 (FZ1)10,25	92 110 110F	1167	910 RBRIE NRBRIE	9-20 (40)	1276	HM	lamp use
3.7.3	3865	(AD5)315,318,320 (FP6)50,54,57 (FQ4)3	92 110		R805E 822CR RBRIE	15-25	57	HM	
3.7.3	3873	(AD5)319 (FN6)6 (FP6)9 (FQ3)53 (FZ1)11 (FQ3)58	110	851	910 RBRIE	9-23	84	HM	
3.7.3	3881	(FO6)134,185 (FP6)61,143,154,155,171 (FP7)35,112 (FQ4)33 (FP6)56 (TG5)137	92 110 110F		825E1CR 910 RBRIE	16-22	65	HM	
3.7.3	3882		110		910 RBRIE	16-37	33	HM	
3.7.3	3900		92 110 110F		RBRIE	12	4	HM	
3.7.3	3966		92 110 110F		910 RBR TOP RBRIE	10-20	125	HM	
3.7.3	4194		110		825E1CR RBRIE	22	14	HM	
3.7.3	4270		92		RBRIE	20	6	HM	
3.7.3	+4655	F1 (FO7)77 (FP6)98 (FP7)2 (FZ2)25	110	200	R805E 820E1CR RBRIE	18-27	162	HM	
3.7.4	2570	(AC5)25/32,92,112 (AD5)20,157,207,224,246 (BD2)49 (FO7)2,31,68 (FQ3)9,58,60 (FQ4)3,6,88,98 (FR3)0,14 (FS3)3 (FT3)22	69 92 110	117g	820E1CR RBRIE NRBRIE	11-24	1033	HM WM	
3.7.4	2836	(AB5)248 (AC6)30 (AD5)151,214,268,289 (FO6)34,37,46,75,91,109,116 (FO7)31 (FP7)23,95 (FQ3)43 (FQ4)33,115 (FR3)1,2,13,14,15 (PR4)9 (FS3)2,4 (FT3)3,4,7,8,9 (FZ1)10	92 110		820R 910 RBRIE	8-19	1516	HM	
3.7.4	2862	(AC5)50,57 (AD5)59,69 (BD2)99,100 (FO6)62 (FO7)1,20 (FP7)15,23 (FT3)3,5	89 92 94 110		820R 825E1R 910 CRR RBRIE	10-20	343	HM WM	
3.7.4	2892	(AC5)92,112,113 (AD5)168,269 (BD2)100 (FO6)90,116,129 (FO7)22,78 (FP6)2,57,70,159,161,179 (FP7)2,5,15,17,23,59 (FQ3)9 (FQ4)37 (FR3)0,12,14 (FS3)28 (FT3)3	11 92 94 110		820R 910 RBRIE NRBRIE	9-20	798	HM	
3.7.4	2971	(AB4)23 (AC5)82,131,132 (AD5)133,207,219,230,273 (AD6)16,19 (FN6)1 (FO6)34,48,90 (FO7)30 (FP7)15,53 (FQ3)58 (FQ4)37 (FR3)4,12,14,15 (FR4)7 (FS3)6 (FT3)3 (FZ2)32 (FN6)3	65,69,92,110	1137	805E1V 820E1W RBRIE	8-22	1225	HM WM	
3.7.4	2971a	(AC5)78,93,94,105,111,113,114,126,131,132,145 (AC6)72,79 (AD5)67,162,164,168,190,203,207,214,215,217,219,224,227,236,256,258,259,260,276,278,279,287,288,299,306,313 (AD6)13,16 CFA 75 (FO6)1,28,52,75 (FO7)1,2,65,76 (FP6)9,20,109,149,153,161,188 (FP7)35,48,74,81,117 (FQ3)26 (FQ4)2,7,21,23,35,55,59,78,98,112 (FR3)2,4,14,19 (FR4)7,9 (FS3)6,11,13 (FZ1)25	92		RBRIE	12	13	HM	
3.7.4	3171		22 69 92 92C 110		OBL800E R805E1 822CR V825E1 910 RBRIE	10-23	4935	HM WM SW	(FO6) lamp use
3.7.4	3460	(AD5)164,217 (CF4)65,88 (FO7)56 (FR3)14 (JG2)180 (150)	92 106 110		R805E 820R 822R RBRIE	10-16	115	HM	
3.7.4	3467	(AC5)127 (AD5)225,28 (FO6)37 (FP6)1 (FR3)0 (FZ1)1 (TG5)96,115,127	92 110		910 RBRIE	6-15	119	HM	

Fig. no.	Type	Provenance	Fabric	Dec.	Surface treatment	Dia.	%	Man.	Comments
3.7.4	3469	(AC5)78,116,117,131,132,162 (AD5)249,268,272,273,276,293 (CE4)37 (FO6)1,15,37,52,62,75,92,96,134,173 (FO7)2,3,20,30,69,79,85,94 (FP6)1, 3,9,10,24,31,36,37,49,54,56,57,61,74,134,137,138,143,144,188 (FP7)2,10, 12,17,23,28,34,38,42,45,50,52,53,54,59,63,68,82,87,123,161,181 (FP7)15 (FQ3)8,20,58,65 (FQ4)2,3,8,19,23,46 (FR3)0 (FR4)1,9 (FZ1)1,8 (FZ2)1 (AC5)78,112,114,128,131 (AD6)14 (FO6)37,41,46,180 (FO7)1,2,31,52 (FP6)9,144,188 (FP7)23,26,48,81,102,103,111,184 (FQ3)52 (FQ4)2,37,113 (FR3)0 (FZ1)1,9	69 92 110 110C	1137	R825E CR 910 RBRIE	(3)9-15 (23)	6326	HM	lamp use; other example oil soaked, Bldg F1 Rm IV
3.7.4	3470	(AC5)126,144 (AD5)272,273 (CF4)51 (FO6)19,53,132,172 (FO7)3,38,39,73,84,85,90,96 (FP6)1,31,98,135,188 (FP7)11,12,17,19A, 34,53,59,63,74,95,106,151,156 (FQ4)19,20,25,26,37,59,98 (FR3)0 (FZ1)9 (AC5)79 (FO6)37,48,59,63,90,98,99,121 (FO7)40 (FP7)23,54	92 110		8-14 (21)	458	HM WM	1 oil soaked	
3.7.4	3473	(AC5)116 (AD5)283 (CF4)26 (FO6)37,54,59,62,63,71,93,98,100, 116,118,150,155,160,167 (FO7)1,20,25,36A,68,69,94 (FP6)1,2,5,9,14, 24,32,34,37,38,40,60,61,89,92,105,118,128,131,188 (FP7)12,15,21,30, 55,59,74,99,102,103,106,123,124,157 (FQ3)59 (FQ4)2,55,80,98 (FZ1)25 (HA2)188 gr. 79; 267 gr. 213 (TG5)6,112	69 92 110	139g, 244g 1137	OB LR805E 820R 825 BR 825 Y 825 R 910 RBRE RBRIE	9-18 (24)	5675	HM WM	oil soaked lamp use
3.7.4	3768	(AC5)145,174 (AD5)217,315 (FO6)28,91,97 (FP6)9,70,72,92,137, 156,162,169 (FQ3)26,43 (FR4)9 (FZ1)2,10,11 (FZ2)1 (GD3)12 gr. 11 (TG5)130	92 110		10-16	141	HM		
3.7.4	3862	(FO7)22B,78,90 (FP6)34,66,97,138 (FP7)27,159 (FZ1)8,9 (AB5)59,346 (AC5)37 (AC6)40,54 (AD5)67,214,217,241,242 (BC4)2 (BD2)80 (BE2)50 (BF2)1 (FP7)18 (FS3)6 (HA2)36 gr. 31,45 - (TG5)4,35 (AB5)63,66 (AC5)107,117,145,174 (AD5)164,168,255,258,272,278, 281,299,315 FC4 16 (FP6)134,172 (FP7)38,49 (FQ4)37 (FR3)0 (FZ1)10 (FZ2)22 (TG5)89	69 92 92L 110 110F		9-18 (24)	5675	HM WM	oil soaked lamp use	
3.7.4	3880	(AC5)145,174 (AD5)217,315 (FO6)28,91,97 (FP6)9,70,72,92,137, 156,162,169 (FQ3)26,43 (FR4)9 (FZ1)2,10,11 (FZ2)1 (GD3)12 gr. 11 (TG5)130	92 110		9-21	794	HM		
3.7.4	4159	(FO6)41	92/110		10	100	HM	complete	
3.7.4	4173	(FP6)9	110		11	100	HM	complete lamp use	
3.7.4	4628	(FO7)22B,78,90 (FP6)34,66,97,138 (FP7)27,159 (FZ1)8,9	110		11-20	433	HM		
3.7.5	2011	(AB5)59,346 (AC5)37 (AC6)40,54 (AD5)67,214,217,241,242 (BC4)2 (BD2)80 (BE2)50 (BF2)1 (FP7)18 (FS3)6 (HA2)36 gr. 31,45 - (TG5)4,35 (AB5)63,66 (AC5)107,117,145,174 (AD5)164,168,255,258,272,278, 281,299,315 FC4 16 (FP6)134,172 (FP7)38,49 (FQ4)37 (FR3)0 (FZ1)10 (FZ2)22 (TG5)89	14 27 69 92 92F 93 94 106 110		820ER 825IP 825IR 830ER/CR 910 RBRIE	5-25	278	HM WM	
3.7.5	2627	(AB4)20 (AC5)13,46,77,79,83,85,92,105,112,125,126,127,129,131,144, 162,173 (AC6)45,79,84,86 (AD5)55,164,168,183,203,207,24,215,217, 224,232,235,236,239,242,246,248,254,257,258,259,269,272, 273,293, 296,298 (AD6)5,11,13,14,20 (FN6)6 (FO6)2,15,37,62,155,167,175 (FO7)68 (FP6)1,34,37,54,56,74,90,118,169,179 (FP7)12,17,82,111,117,191 (FQ3)42,47,92 (FQ4)2,6,7,21,79,94,112 (FR3)12,14 (FR4)7 (FZ1)2 (TG5)137	65 80 92 110 110F		R805E 822CR 910 RBRIE RBR TOP	9-21	794	HM	
3.7.5	2846	(AB4)20 (AC5)13,46,77,79,83,85,92,105,112,125,126,127,129,131,144, 162,173 (AC6)45,79,84,86 (AD5)55,164,168,183,203,207,24,215,217, 224,232,235,236,239,242,246,248,254,257,258,259,269,272, 273,293, 296,298 (AD6)5,11,13,14,20 (FN6)6 (FO6)2,15,37,62,155,167,175 (FO7)68 (FP6)1,34,37,54,56,74,90,118,169,179 (FP7)12,17,82,111,117,191 (FQ3)42,47,92 (FQ4)2,6,7,21,79,94,112 (FR3)12,14 (FR4)7 (FZ1)2 (TG5)137	69 81? 92 92L 94 110 110F		R805E R805E H 805I 822CR 825E CR 825ER 910 RBRIE	9-24	1642	HM WM	
3.7.5	2880	(AC5)46,68,78,82,99,102,108,111,124,144,170 (AC6)30,71,86 (AD5)59, 127,203,214,217,219,224,227,230,232,246,249,250,254,259,273,278, 287,288,293,295,296,311,315 (CF4) 155 (FO6)2,11,37,71,93,106,109, 160,184 (FO7)68 (FP6)1,3,9,31,54,56,74 (FP7)2,15,23,31,181 (FQ3)20,43 (FQ4)8,23,37,55,98,113,114,122 (FR3)22 (FS3)4 (FZ1)1	19 25 69 92 110	1137	805I H805E R805E H 810I 820ER 820 CR 822CR 825E R 910 RBRIE	11-22	4349	HM	(AC5)105,108 & 111 999; (AD5)219 & 227 999 some lamp use

Fig. no.	Type	Provenance	Fabric	Dec.	Surface treatment	Dia.	%	Man.	Comments
3.7.5	2923	(AB4)22 (AD5)167 (FP7)2,52,99 (FZ1)2 (TG5)46	92 94 110		RBRIE	11-15	84	HM WM	some sooty int
3.7.5	2934	(AB4)32 (AC5)68,78,79,111,112,144,176 (AD5)155,162,167,168,186,198,219,277 (AD6)14,23 (FO6)1,122 (FO7)36,42C,68 (FP6)9,90,95,156,171 PF7 106 (FQ4)2,3 (FZ1)12 (TG5)29-105	16 69 92 94 110		820ER 822CR 825IW RBRIE NRBRIE	7-22	755	HM WM	
3.7.5	3182	(AD6)16 (FO6)53 (FQ4)59 (FR3)0,2,12 (FS3)6,11 (TG5)5/4	69 92 94 110		V8001 825EIP 910 RBRIE	15-30	82	HM WM	
3.7.5	3411	(AC5)68,73,78,82,83,85,112,114,116,124,127,128,129,131,134,158,164,172,174 (AD5)219,246,249,255,256,258,260,272,276,278,279,282,283,288,289,294,298,323 (AD6)20 F1 153 (FN6)2,3,6,9 (FO6)2,3,15,19,25,34,35,37,46,47,66,50,52/62,53,54,56,58,59,60,61,62,63,66,71,90,92,93,97,98,100,106,107,111,113,114,115,118,121,125,129,130,131,132,138,145,148,150,155,157,160,167,180,183,185,192 (FO7)1,16,25,31,44,57,68,69,73,80,85,123 (FP6)1,4,5,9,10,21,24,25,29,37,38,40,50,60,66,67,70,72,73,83,96,111,118,120,125,128,143,146,147,149,151,153,154,155,156,159,171,172,178 (FP7)1,2,10,11,12,18,19,21,22,23,26,31,32,34,35,38,39,45,47,48,53,54,55,64,72,74,82,84,90,92,93,102,105,116,117,119,123,124,126,130,133,137,141,142,144,148,149,150,151,152,153,160,161,179/188,191,256 FP8 1 (FQ3)8,9,22,24,42,43,44,48,58,59,60,61,63,69 (FQ4)2,5,6,7,8,20,23,24,26,27,35,37,39,46,48,49,55,56,59,61,62,63,66,68,75,77,78,79,80,88,96,98,104,112,113,116,119D,122,124 (FQ/R4)2 (FR3)15 (FR4)1,3,6,7,9,10 (FZ1)2,7,8,9,24,25,27 (FZ2)1,22,31,56 (GD3)14 (11)(TG5)73,74	92 110	1112	RV800E 805IH 820ER 822CR 825ECCR 910 RBRIE	9-21	36791	HM WM	lamp use in Building F1 oil soaked
3.7.5	3485	(AC5)85,112 (AD5)219 (FO6)75 (FQ4)75 (FR4)9 (TG5)112	92 110		910 RBRIE	13-25	121	HM	
3.7.5	3704	(AC5)117 (AD5)227,258 (FQ4)7 (FR4)7	69 92 110		820R 910 RBRIE	8-15	65	HM	
3.7.5	3705	(AD5)227,319	69 110		R805EI RBRIE	5-7	21	HM	
3.7.5	3750	(AD5)225 (FP7)53 (FZ2)1	110		R805E RBRIE	12-19	28	HM	deformed
3.7.5	3786	(AC5)73 (AD5)236,241,242,283 (FN6)1,2 (FO6)53,66,129,154,179 (FO7)73 (FP6)5,8,9,20,34,37,57,60,61,81,98,119,154,162 (FP7)5,30,130,152,153,179/188 (FQ3)58 (FQ4)5,6,44,48,49 (FZ1)2,8,9,10,12,25,32 (FZ2)25 (TG5)112,113,116,127	82 92 110		805E R805E 820ECCR 820EOR 822CR 822R 910 RBRIE	12-20 (23)	1656	HM	
3.7.5	3830	(AC5)131 (FO6)13 (FO7)101 (FP6)2,24,29,97,125,143,154,171,172 (FP7)23,38,72,123,153 (FQ3)58 (FZ1)27	92 110		H805E R805E 910 RBRIE	(7)11-20	579	HM	1 B hole?
3.7.5	+3861	(AD5)283 (FO6)37,46,58 (FO7)101 (FP6)6,171 (FQ3)69 (TG5)113	92 110		R805E 822CR RBRIE	13-20	221	HM	
3.7.5	3973	(FO6)59 (FQ4)98	92		RBRIE	13-17	108	HM	(FQ4) complete
3.7.5	4170	(FP6)1,3	92		H8001 H802 RBRIE	12	27	WM	
3.7.5	4339	(FP6)9	110		R805EI	14	49	HM	
3.7.5	+4630	(FP6)136,143,161 (FP7)5,14,52,95 (FZ2)1 (GD3)141 (138)	92 110		R805E 820ER RBRIE R805EI 825EIO OBL RBRIE	13-18 13-14	287 74	HM HM	1 complete
3.7.5	4631	(FP6)134,135 PF7 17	92 110		RBRIE	13-14	74	HM	
3.7.5	4634	(FP7)52,53 (FZ1)12	110		RBRIE	13-16	160	HM	
3.7.5	4635	F07 39 (FP6)144 (FP7)48,68	110		R805E RBRIE	13-15	79	HM	

Fig. no.	Type	Provenance	Fabric	Dec.	Surface treatment	Dia.	%	Man.	Comments
3.7.5	4636	(FP7)23	110		RBRIE	14	29	HM	
3.7.5	4644	(FO7)42C (FP7)50,52	92 110		R805E RBRIE	12-15	80	HM	(FO7) lamp use?
3.7.5	4707	(FP6)156	110		R805E RBRIE	9	54	HM	complete
3.7.5	+4783	(GD3)107A (98)	92		RBRIE	12	100	WM	B mould-made
3.7.6	2510	(AB6)1,8,13 (AC5)36,37,64,68,73, 114,124,144,165 (AC6)31,71,77,84 (AD5)128,162,168,186,203,207,215,219,224,227,230,236,242, 249,279,289 (AD6)1,4,13,16 (FO7)39 (FP6)143,154,155,172 (FP7)2,10,12,45,130,153 (FQ3)3 (FR3)14,22 (FS3)4,11,13,14 (FZ2)1 (AB5)229,277,354 (AC5)82,92,99,113,126,132,148 (AC6)54,57,61,79 (AD5)87,162,164,168,184,185,207,215,224,227,241,251,255,258,259, 272,283,296,309 (AD6)5,11,12,19 (FP6)188 (FP7)52 (FQ3)61 (TG5)85-94	69 92 110		910 RBRIE	11-24	1196	HM WM	
3.7.6	2844		25 65 69 92 92C 94 110		R805EI 820ECR 822CR 825ECR 910 RBRIE	12-21	1304	HM WM	
3.7.6	3360	(AC5)107,116 (AD5)146,304 (AD6)20 (FP7)2	69 92 110		822CR RBRI RBRIE	9-25	75	HM WM	
3.7.6	3405	(AC5)79,82,84,105,112,127,145,172,174 (AD5)162,215,226,259,282,293, 309,310,311 (AD6)14,20 (FO6)122,125,155,167 (FO7)40 (FP6)9 (FQ3)3 (FQ4)35,78,98 (FR4)9	92 110	1137	V805E H805I 822CR 825ECR 910 RBRIE	11-22 (26)	555	HM	
3.7.6	3410	(AC5)68,73,78,79,82,83,84,85,89,92,102,107,108,111,112,114,116,117, 123,125,126,127,128,129,132,134,135,144,145,148,151,155,158,162, 164,170,172,174,176,178 (AD5)207,214,230,239,246,249,251,254,255, 256,257,258,259,260,268,272,273,276,277,278,279,281,283,287,288, 289,293,294,296,298,309,310,311,312,315,317,318,319,322 (AD6)14,20 (FO6)2,62,63,66, 71,75,89,97,106,111,114,116,121,122,125,132,14 5,148,155,160 (FP6)1,3,4,5,6,9,10,14,21,28,31,32,34,36,38,40,54,57 (FQ3)8,20,43,48,58,61 (FQ4)2,7,21,23,26,37,59,61,62,63,68,75,77,78,80, 88,113 (FR3)0 (FR4)1,7,9 (TG5)73	69 80 92 110 110F		800E H810I R810E 820ECR 822CR 825ECR 910 RBRIE	12-24 (25-31)	11740	HM	
3.7.6	3472	(AC5)92,112,116,126,131,134 (AD5)242,256,258,269,312 (FO6)1,172 (FO7)73 (FP6)1,32,72,179 (FP7)17 (FQ4)21,23,35,37 (FR3)0 (FR4)9 (FZ1)10	92 110		V805EI 822CR 910 RBRIE	11-22	329	HM	fish bone impression
3.7.6	3700	(AC5)94,145,174 (AD5)207,232,255,304,320 (FO7)78 (FP7)5 (FQ3)58 (FQ4)59,80,98,114	92 110		822R 825ECR 910 RBRIE	11-22	216	HM	
3.7.6	3701	(AD5)227 (FO6)122	92 110		RBRIE	12-13	181	HM	complete
3.7.6	3806	(AD5)272,289 (FN6)6 (FO6)13,19,92,98,100,109,129 (FO7)2 (FP6)85,92, 134,137,138,143,151,154 (FP7)1,2,1,7,28,35,48,55 (FQ4)7,23,33 (FZ1)12 (TG5)6	92 92L 110		822CR V825EICR RBRIE	12-22	1737	HM	oil soaked
3.7.6	3808	(AC5)114 (AD5)272,282 (FO6)46,61,62 (FP6)9	92 110 110L	1137	822CR RBRIE	12.5-17	287	HM	
3.7.6	3811	(AC5)99,112 (FO6)34 (FO7)1,3,52 (FP6)60,128,153,170,181 (FP7)10,119 (FZ1)8	92 110 110F		805EI R805I 910 RBRIE	12-20	177	HM	
3.7.6	3819	(AC5)112 (AD5)227,276 (FO6)66,90,132 (FO7)1,39 (FP6)21,56 (FP7)48,53 (TG5)77	92 110		RBRIE	11-16 (25)	282	HM	
3.7.6	3820	(AD5)276 (FO7)20 (FP6)54 (FP7)23 (FQ3)58 (FQ4)2	92 110		825ER 910 RBRIE	11-14 (23-25)	94	HM	

Fig. no.	Type	Provenance	Fabric	Dec.	Surface treatment	Dia.	%	Man.	Comments
3.7.6	3823	(AC5)112 (AD5)227 (FO6)1,90,129 (FO7)1,2,3,11,20,31,73 (FP6)9,31,36,49,57,90,156 (FP7)1,5,17,19,23,26,34,48,59,82 (FQ3)56 (FO4)46 (FZ1)9 (TG5)12,91	92 110	1137	R805E 820EBR 820EW 910 RBRIE	10-17	969	HM WM	lamp use deformed (TG5)12,91 WM
3.7.6	3831	(AC5)126,129,131 (AD5)246,258,294,296,309 (AD6)20 (CF4)96,133 (FN6)2,9 (FO6)37,46,48,50,52,53,58,59,61,62,90,91,93,99,109,111 (FO7)2,25,90 (FP6)1,2,5,9,20,21,24,29,31,37,49,56,72,128,144 (FP7)2,17,184 (FQ3)9,41 (FQ4)35 (FZ1)1,2,9,10 (GD3)12 gr. 11 (TG5)5/4,76,102-105,115	92 94 110	128g 1167	R805E 820ECR 822CR 825E1CR 910 RBRIE	11-24	4149	HM	lamp use
3.7.6	3841	(AD5)256 (FO6)37,116 (TG5)46	92 110		RBRIE	12-21	101	HM WM	
3.7.6	+3858	(AC5)140 (AD5)283 (FO6)47 (FO7)20 (FP6)9,31,143,156,159 (FP7)17,52,112 (FN6)1,3 (FQ3)26 (GD3)79C (11)(TG5)79	92 92C 110		R805E 822CR 825EBEIGE RBRIE	12-15	892	HM	
3.7.6	3864	(AC5)131,145 (AD5)296 (FO6)53,71,116,167 (FP7)15,31,48 (FZ1)8 (TG5)5/4	92 110		805EV 822CR 825IR RBRIE	13-20	221	HM	
3.7.6	3876	(AC5)116 (FO6)61 (FP6)133 (FP7)15,17,35 (FZ1)10,25	92 110		822CR 805EOBL RBRIE	11-15	855	HM	
3.7.6	4104	(FO6)37	110		RBRIE	14	29	HM	lamp use
3.7.6	4105a	(FO6)62	110		RBRIE	13	26	HM	lamp use
3.7.6	4112	(FO6)91	110		R805E RBRIE	12	30	HM	
3.7.6	4683	(FP7)5	110		RBRIE	13	96	HM	
3.7.7	415	(AB5)1,59 (AC5)68 (AC6)27,30 (AD5)162,164 (AD6)5 (BD2)71,81,82 (BE3)63 (BF2)11 (BF3)8 (FO7)101 (FP6)188	69 92 94 110		R805E 820ER 820IR H820IR 822R 822CR 825ER 910 RBRI RBRIE	10-24	1256	HM WM	
3.7.7	2509	(AB4)1 (AB5)59,67,347 (AB6)1,8,9,10,11,12,16,20,24,27 (AC5)12,36,57,67,68,73,77,78,79,82,85,88,92,93,94,99,102,103,105,107,108,111,112,114,116,117,124 125,126,127,128,129,131,132,134,145,153,158,162,164,171,174 (AC6)14,16,17,20,22,27,30,31,34,36,37,40,54,57,58,61,71,77,79,86 (AD5)59,151,157,164,168,184,185,186,203,207,214,215,217,219,224,225,227,235,236,239,241,242,246,249,250,251,254,262,255,256,257,258,259,260,269,272,273,276,278,279,281,283,288,289,293,294,296,298,299,309,310,311,312,315,316,318,319 (AD6)1,4,5,11,13,14,16,19,23 (BD2)28,100 (FN6)3,6,9 (FO6)15,34,37,46,47,50,52,53,54,58,59,62,63,71,89,90,91,98,100,103,107,109,113,114,115,125,129,132,145,148,155,157,167,174,175,185 (FO7)65,71,73,85,96 (FP6)1,3,4,5,9,10,20,21,24,28,29,31,32,34,36,37,40,49,54,56,60,61,66,72,73,96,97,105,109,118,119,120,128,131,134,135,137,138,143,146,151,153,154,155,156,159,161,169,171,172,188 (FP7)1,2,10,12,17,35,64,74,82,106,112,123,142,161 (FQ3)3,8,22,26,43,58,59,63 (FQ4)2,3,6,7,8 21,23,24,25,26,27,35,37,46,59,61,62,63,64,66,68,77,78,79,80,88,98,113,115 (FR3)0,14 (FR4)2,3,7,9,10,13 (FS3)4,11 (FZ1)10 (GD3)32 gr. 55 (TG5)29,29-105,91,112,113,120	1 2 9 11 69 89 92 94 110	1112	R8051 R812 825IR 910 RBRI RBRIE	(10)14- 26 (40)	19960	HM WM	

Fig. no.	Type	Provenance	Fabric	Dec.	Surface treatment	Dia.	%	Man.	Comments
3.7.7	2869	(AB4)23 (AB5)207 (AC5)64 (FP7)123 (HA2)213 gr. 267	63 69 92 110		820IW RBRIE	15-30	42	HM WM	
3.7.7	2963	(AB4)23 (TG5)1	25 92			8-17	681	HM WM	
3.7.7	3158	(FT3)1	92		RBRIE	18	5	WM	
3.7.7	3382	(AD5)112,287 (AD6)19 (FP6)144 (FP7)12,130 (FS3)24	92 110		822 825ER 825EIR 910 RBRIE	13-21	89	HM WM SW	
3.7.7	3404	(AC5)82,126,131,145 (AD5)162,235,315,323 (AD6)19 (FO6)15 (FO7)1,2,11,23,25,31,40,52 (FP6)70,74,89,92,95,128 (FP7)1,17,19,23,26,31,34,35,55,82,111 (FQ3)9,26,48,61 (FQ4)46,64,98 (FR4)7 (FS3)6	69 92 92L 110		910 RBRI RBRIE	10-25	989	HM	
3.7.7	3428	(AC5)39 (AD5)289 (FQ3)42 (FQ4)46,77	92 110		H8001 820EBL 910 RBRI	16-21	35	HM WM	
3.7.7	3478	(AD5)215	92		RBRE	23	3	WM	lid?
3.7.7	3715	(AD5)224	92		RBRIE	9	10	HM	
3.7.7	3754	(AD6)16 (FN6)6 (FO6)1,98,131,167,180,181 (FO7)30,44,69,73 (FP6)74,81,90,92,95,111,119,125,143,156 (FP7)2,14,18,21,23,39,72,102,111,184 (FQ3)59 (FZ1)2,8,10,24 (FZ2)25,48,53 (GD3)14 (11)(TG5)74	92 92L 110		805I 910 RBRI RBRIE	13-25	958	HM WM	
3.7.7	3757	(AD5)257 (AD6)19 (FN6)6 (FO6)71,121,122,157,172 (FP7)21,82 (FP8)1 (FZ1)9 (FZ2)22 (TG5)77	92 110		910 RBRI RBRIE	13-26	190	HM WM	
3.7.7	3785	(AD5)250 (CE4)71 (FO6)160,185 (FO7)31 (FP6)5,81,92,98,149 (FP7)15,22,23,95 (FZ2)25 (JG2)1	80 92 110		910 CRR RBRI RBRIE	15-22 (30)	278	HM	
3.7.7	3816 a&b	(AC5)171 (AD5)258,276,279,288,293,299,322 (FN6)2,6 (FO6)61,75,167,172,181 (FO7)12,68 (FP6)34,66,70,73,74,81,102,125,138,146,162 (FP7)14,21,23,59,136,150 (FQ3)40 (FQ4)86,112 (FR4)1,7 (FZ1)8 (FZ2)1,25,49,55 (GD3)125 gr. 119/136	92 92C 94 110 110F		825IR 910 RBRI RBRIE	14-23 (28)	1140	HM	
3.7.7	3877	(AC5)116,131,132 (FO6)2,160 (FP7)10,23 (FQ4)78 (FR4)13	92 110		805I 910 RBRI	12-22	207	HM	
3.7.7	3971	(FQ4)75	92			20	4	HM	
3.7.7	4107	(FO6)92	92		R805E RBRIE	16	15	HM	
3.7.7	4151	(FO6)41	-		910 RBRI	18,5	100	HM	complete
3.7.7	4167	(FO6)40,160	92 110		910 RBRI RBRIE	13-18	84	HM	
3.7.7	4168	(FO6)160	92 110		RBRI RBRIE	13-17	78	HM	
3.7.7	4183	(FP6)31	110		R810E RBRIE	13	100	HM	lamp use?
3.7.7	4708	(FP7)112	92	216g	910 RBRI	19	58	HM	
3.7.7	4719	(FZ1)12	110	dribble	RBRIE	20	9	HM	
3.7.7	4760	(FP6)179	110		RBRIE	13	30	HM	
3.7.7	4807	(FZ1)10	110		910 RBRI	16	10	HM	
3.7.8	300	(AC6)14 (AD6)5 (BC2)3 (BD2)24,45,47,61 (BD3)28 (BE1)9 (BE2)10,32,48,50,103,145 (BE3)44,55,63,106 (BF1)13,57 (BF2)37,39 (BF3)17 (CE4)48 (CF5)1 (FP6)147,179 (FP7)38,74,152 (FZ1)2,10 (FZ2)1	1 2 9 67 69 92 94 117	1112	805EI 820ER 825EIGR 822R V822R 910 RBRI	8-32 (55)	281	HM WM	

Fig. no.	Type	Provenance	Fabric	Dec.	Surface treatment	Dia.	%	Man.	Comments
3.7.8	300a	(BD2)50,69,71 (BD3)8 (BE2)1,121 (BE3)15,55 (FP6)137 (FR3)12	67 92 94 110	5 200	820ER 822R 910 CRR	10-23	124	HM SW	sooty exterior
3.7.8	2030	(BE2)1,68 (BE3)1 (FT3)2	6 67 92	31g 1001	810E	19-33	62	HM WM	
3.7.8	2050b	(AB4)10,11 (AB5)20,25,32,58,62,66,68,80,89,91,94 (AC5)61 (AC6)84 (AD5)69,116,230 (AD6)16 (BD2)100 (BD3)5 (BE1)51 (BE2)10,37,48,71,101,116,128 (BE4)19 (BF3)26 (CE4)98 (CF4)50,65,88,113 (CF5)2 (FO6)47 (FP6)172 (FP7)26 (FQ3)9,42,43 (FR4)2 (FS3)1 (FT3)1,4 (FZ)1 (JE2)1 (JG2)183 (150)(TG5)1,18,46 (ZH5)15,37,53,55	2 67 69 80 92 93 94 94L 95 110	1017 1112	820ER 820EW 822R 825EW	6-30	1153	HM WM SW	
3.7.8	2074	(AB5)4,59 (AB6)11 (BD2)65,69 (BE2)73 (BF2)34	32 67 69 92 94	200		12-32	35	HM WM	
3.7.8	2149	(BE3)10,18 (BF1)56 (BF2)37 (CF4)117	67 69 92 94 106		822W	17-28	32	HM WM	
3.7.8	2255	(AB4)1,7,11,23 (AB5)1,3,14,35,40,66,80,229 (AB6)3 (AC6)1,14,20,27,30,37 (AD5)161,227,268 (AD6)5 (BC2)2,4 BC3 3 (BC4)1 (BD2)28,29,71,94,101 (BD3)5,9,28 (BD4)17 (BE2)17,48,50,57,71,73,103,117,158 (BE3)10,16,18,27 (BE4)9,16,19 (BF1)56 (CF3)6,8 (CF4)1,51,56,73 (FO6)145 (FR3)1,14,15,22 (FS3)1,2,3,14 (FT3)5 (TG5)73,76 (ZH5)43 1098 4	1,2 11 25 56 65 67 69 79 80 92 94 95 110	1037 850	820ER H820ER 822gr. 822O 822R V822R 825EW 825ER 825EIR 830EW 820IW 910 RBRIE	9-28	1327	HM WM	
3.7.8	2259	(AB5)348 (AB6)8 (AC5)13,28,34,37,38 (AD5)31,262 (BD2)32 (BD3)9 (BE1)61 (BE2)1,103 (CE4)2,47 (CF3)2 (CF4)155 (FO6)1 (FP6)9 (FP7)15 (FQ3)58,65 (FQ4)113 (FR3)1,22 (FR4)9 (JD2)43	11 65 67 89 92 94 94C 110	1017	910 RBRIE	11-28	221	HM WM	deformed
3.7.8	2261	(AB4)4 (AB5)42,91,94 (AD5)112 (BD2)65 (BF3)23 (CF4)102 (FQ3)8 (FR3)1	1 92 94 110	8	825ER 910 RBR RBRB RBRIE	19-22 (30-40)	122	HM	
3.7.8	2310	(AB4)1,20 (AB5)59 (AB6)1 (AC5)37,73,85,107,124,126,127,129,131,162 (AC6)4,14,22 (AD5)1,113,227,232,242,251,257,259,260,272,273,276,278,283,288,296 (AD6)5,19,20 (BD2)28,59 (BD3)8 (BE2)37,51,67,147 (BE3)10 (BE4)60 (BF1)4,45,56,73 (BF3)38 (CE4)42,69,78 (CE5)6 (CF3)1 (CF4)159 (CF5)4 (FO6)13 (FO7)1,68 (FP6)9,34,36,56,61 (FP7)23 (FQ3)26,42,69 (FQ4)6,8,20,21,26,35,77,84,112 (FR3)0,12,14,22,27,28 (FR4)2,3,7,9 (FS3)11,13 (FT3)67 (HA2)83 gr. 225,213 gr. 267 (JG2)18 gr. 2 (TG5)1,4,12,18,29,73,74,87,91,94,102,102-105,109,112,119,127 (ZH5)40 (AB5)40 (AD5)311 (BE2)26,52,71 (BE4)9 (CE4)20,85,97 (CF4)7,65 (FO6)11,15 (FP6)92 (FQ3)42 (FQ4)63,96,112 (FZ1)1 (TG5)74,85-94 (AB5)59 (AB6)13 (AC6)22,30 (BD2)45,70,71,101 (BE1)7,9,80 (BE2)103 (BE3)20 (BF1)73 (CE4)78,98 (CF4)17,111 (FO6)1 (FP7)2 (FR3)22 (FZ2)1 (HA2)68 gr. 204 (TG5)4/5,29-105,74,120	2 63 65 67 69 80 92 92C 93 94 95 106 110	1017 850/851 x 2	820ER 822R 825EIP 825EW 910 CRR RBR TOP RBRIE	11-27 (35-42)	1774	HM WM	
3.7.8	2344	(AB5)40 (AD5)311 (BE2)26,52,71 (BE4)9 (CE4)20,85,97 (CF4)7,65 (FO6)11,15 (FP6)92 (FQ3)42 (FQ4)63,96,112 (FZ1)1 (TG5)74,85-94 (AB5)59 (AB6)13 (AC6)22,30 (BD2)45,70,71,101 (BE1)7,9,80 (BE2)103 (BE3)20 (BF1)73 (CE4)78,98 (CF4)17,111 (FO6)1 (FP7)2 (FR3)22 (FZ2)1 (HA2)68 gr. 204 (TG5)4/5,29-105,74,120	2 3 6 22 92 92C 110	5 1017 1281	820ER 822R 822BL 910 RBRIE	7-21	150	HM WM	(FP6)92 Kerma
3.7.8	2345	(AB5)59 (AB6)13 (AC6)22,30 (BD2)45,70,71,101 (BE1)7,9,80 (BE2)103 (BE3)20 (BF1)73 (CE4)78,98 (CF4)17,111 (FO6)1 (FP7)2 (FR3)22 (FZ2)1 (HA2)68 gr. 204 (TG5)4/5,29-105,74,120	65 67 80 92 94 110	1015 1112	822R 910 RBR	13-27	325	HM WM	lamp use
3.7.8	2452	(AB5)38 (AD5)1,160,193 (BD4)19 (BE3)18 (CF4)139 (FR3)12	1 65 69 92			10-25	73	HM WM	

Fig. no.	Type	Provenance	Fabric	Dec.	Surface treatment	Dia.	%	Man.	Comments
3.7.8	2504	(AB6)1 (AC6)31 (AD5)87,227,272,273 (BE3)55 (FR3)28 (FS3)6 (TG5)5/4	1 14 27 92 92F 94		820ER H820ER 820JO 822W RBRIE	7-14	88	HM WM	
3.7.8	2662	(AB4)7 (AC5)17 (BC2)2 (FO6)172 (FR3)14 (FT3)3,22,67	92 110		820ER 825EW RBRIE	5-18	145	HM WM	
3.7.8	2685	(AB4)10,23	69 92		820ER	7-8.5	72	WM	
3.7.8	2758	(AC5)13 (BD2)96 (TG5)65 (ZH5)15	25 65 94 95	1007 1281	820ER 822R	7-13	57	HM WM	
3.7.8	2768	(BF1)11	67	850		19	15	WM	
3.7.8	2772	(AC6)61 (BC2)2 (BD3)28 (CE4)1 (FQ3)3 (FQ4)63	83 92 92C 94 110		820ICR RBR TOP	16-31	42	HM WM	
3.7.8	2790	(AB4)23 (AB5)233 (AC5)17 (BE2)1,31,32,43,109,114 (BE3)20,33,53,55,56,57,78,106,116,118,136 (BE4)9,19,20,48 (BF2)38,39 (BF3)1,8,23,38,50,59	1 2 9 11 22 55 65 66 67 69 83 92 94		820ER 822O 822R 825ER 825IR 825EIR 832CR RBRE RBRI RBRIE BL TOP	14-29	345	HM WM	
3.7.8	2845	(AC5)34,51,116,126 (AC6)59 (AD5)224,276,313 (AD6)5 (BC4)1 (BE2)17 (CE4)32,48,86 (CF3)2 (CF4)96,141,156,163 (FN6)6 (FO6)109 (FO7)54,90 (FP6)4,37,61,95,128 (FP7)17,23,31,34,74,82 (FQ4)1,19,46,104,115 (TG5)100,102	69 89 92 94 106 110	8 1190 1202	820IP 820IR 822R 825EIR 910 RBRIE	14-30 (40)	1552	HM WM	Building F1, Rm III, oil soaked
3.7.8	3090	(AD5)4 (CF4)65,69,112 (TG5)5/4	92 110	1017	910 RBRIE	12-25	48	HM WM	
3.7.8	3239	(AC5)34 (AD5)28 (TG5)100	69 94		H820ER 822P RBRI	12-22	47	WM	
3.7.8	3331	(AD5)113	92		825ER	16	11	WM	
3.7.8	3527	(CE4)1 (HA2)217 gr. 214	25 92	1192	V820R 810I	10.5-15	103	HM	
3.7.8	3551	(FT3)46	110		820ER	24	6	WM	
3.7.8	3553	(FT3)49 (TG5)73	94 107		820IW	14-40	20	WM	(FT3) from brick (TG5) deformed
3.7.8	3679	(CE4)14,20 (CF3)5 (TG5)46	2 94 105 110	1216 850	820ER RBRI	10-23	40	HM WM	
3.7.8	4291	(FP6)8 (TG5)117	92F		822R RBR TOP	12-13	21	WM	
3.7.8	4368	(CF3)1	111		820EBR	7	30	WM	deformed
3.7.8	4409	(CF4)50	130		820ER 825IER	5	24	WM	
3.7.8	4489	(CE5)4 (CF4)161	110			13-15	16	HM	1 no lug
3.7.8	4510	(CE4)47 (JG1)35 gr. 31	92 110	168g		11-17	14	HM	
3.7.8	4525	(CE4)20	110	1112		15	13	HM	
3.7.8	4569	(CF4)163 (JD2)43 gr. 40	92 106		820EP 820IW	11-14	38	HM WM	
3.7.8	4595	(CF3)49	115		820EP/825EW 825IP	6	10	WM	
3.7.8	4652	(FP7)31 FP8 1	6 110		812	5-19	16	HM	(FP7) Kerma
3.7.8	4703	(FP7)10,31,32,74,95,117,150,153,161	92 110		910 RBRI NRRIE	15-23	118	HM	
3.7.8	4759	(BE3)17 (FO7)94	92 110		910	21	47	HM	HS or boss scar deformed
3.7.8	4826	(JE)12	110		820IR	14	20	HM	

Fig. no.	Type	Provenance	Fabric	Dec.	Surface treatment	Dia.	%	Man.	Comments
3.7.9	+2000a	(AB5)67 (AC5)59 (AD5)276 (BD4)16 (BE1)22,61 (BE2)48 (BE2)1,17,32,43,50,51,119 (BE3)1,10,16,55,63,78 (BE4)11,16,19,20 (BF1)11,13,16,56 (BF2)11,31,38 (BF3)8 (BD2)28 (CF3)49 (FO6)63 (FO7)56 (FP7)142 (FQ4)62 (FR3)1,2 (JD2)7,51 (ZH5)15,37,42,43,45 (AD5)112 (BE2)17 (BE3)53 (CE4)85 (CF4)96,113,126,141,161 (FO7)11,56 (FQ3)59 (FQ4)79 (FR3)4,14 (FS3)13 (TG5)138 (AC5)39,46 (AD5)80,112,160,167,227 (AD6)16 (CF4)112 (FR3)0	1 2 8 65 67 69 81 89 92 94 110 1 92 94 94C 94F 110 67 81 92 94 94F 110	5 8 836ER 850 851? 1017 1190 1202 850	825EIgr. 910 CRR NRBR RBRIE 820IR 910 RBRE RBRIE 820ER 820IR 822R 910 RBRIE	13-33 (42)	505	HM WM	sooty exterior
3.7.9	2022d			70g 214g 8 1017 1034 1035 1112 1152 1190 1202 1203 1204 1212 1219 1252 double bosses IR VERT boss 850 851x2 with string marks	H805EI 804E/816 820EBL 820ER 820IR 820EW 820IBL H820ER V820ER 822R 825EBL 825EIP 825ER 825EW 825EIW 910 CRR RBRIE RBR RBRI NRBRIE	12-33	HM WM	sooty exterior	
3.7.9	2025b	(AB4)1,4,7,10,11,14,15,22,23 (AB5)25,29,59,65,66,67,252,302,328 (AB6)11 (AC5)23,28,45,59 (AC6)27 (AD5)1,113,134,161A,260 (AD6)5,11 (BC4)1 (BD2)24,29,33 (BE1)1,9,80,85 (BE2)10,19,37,110,156 (BE3)16,18,27,31,146 (BE4)9,60 (BF1)16,56,57 (BF3)8 (CE4)1,4,34,65,85 (CE5)1 (CF3)13,26,29 (CF4)1,18,59,62,67,69,79,96,101,102,108,113,117,163 (CF5)1,2 (FN6)9 (FO6)37,62,185a (FO7)56 (FP6)9,61,97,105,118,128,151/ 154,171 (F7)81,184 (FQ3)26,42,59 (FQ4)6,27,33M 61,62,67,68,75,86,119G (FR4)2 (FS3)1,3,16 (FT3)5,8,9,10,12 (HA2)1,3 (JC2)21 (JC3)11 (JD2)25 (TG5)1,4,6,46,74,79,87,91,112,117 (ZH5)15,36,37,40,45,55,62,89	1 2 6 50 56 65 67 69 76 80 92 92C 94 95 106 110 110F 111	1017	820ER 825EW 910 RBR TOP 820ER V820ER 822R 825ER 910 RBRIE 825ER 820ER 820IR 822R 822CR 825ER 910 RBRIE 820IR 910 RBRE RBR RBRIE 825EBL 910 RBR TOP RBRE RBRI RBRIE 910 RBRIE 820IR 820ER 822R 825EBG RBR TOP RBRIE	14-32 (36-46)	2862	HM SW WM	(AB4)14 & 15 999 sooty exterior oil soaked (FQ3)42 from brick?
3.7.9	2299	(AB4)11 (AC5)112 BC3 3 (BD2)23 (BD4)19 (BE2)51,158,160 (BF1)57,61 (BF2)51 (BF3)17,33 (CE4)2,85 (CF3)8 (CF4)13,117 (FQ3)56 (TG5)29	1 65 67 69 92 94 110 110C	1017	820ER 825EW 910 RBR TOP 820ER V820ER 822R 825ER 910 RBRIE 825ER 820ER 820IR 822R 822CR 825ER 910 RBRIE 820IR 910 RBRE RBR RBRIE 825EBL 910 RBR TOP RBRE RBRI RBRIE 910 RBRIE 820IR 820ER 822R 825EBG RBR TOP RBRIE	(13)19- 31	HM WM SW		
3.7.9	2328	(AB5)273 (BD2)71,101 (BE1)61 (BE2)10,26,48,110,155 (BE3)26,31 (BF2)22 (CF3)49 (CF4)1,17,103 (FN6)9 (FO6)116,145 (FP6)5,10,24,34 (FQ3)42 (FQ4)61 (FR4)7 (FS3)11,34 (JD2)51 gr. 40 (JG2)182,183 gr. 150 (BE2)43 (BE3)106 (BF2)11,32 (CF3)31 (ZH5)21 (CF3)41 (CF4)17,56,145 (TG5)43 (ZH5)37,38 (FO6)157 (AC6)22 (AD5)41,288 (BF3)30 (CF4)163 (FP7)124 (FQ3)8 (FQ4)113 (FT3)1	1 67 69 92 94 110	1017	820ER V820ER 822R 825ER 910 RBRIE 825ER 820ER 820IR 822R 822CR 825ER 910 RBRIE 820IR 910 RBRE RBR RBRIE 825EBL 910 RBR TOP RBRE RBRI RBRIE 910 RBRIE 820IR 820ER 822R 825EBG RBR TOP RBRIE	13-35	HM WM SW		
3.7.9	3035	(AB5)94 (AC5)112 (AD5)224,283 (FQ3)42 (FQ4)48 (FR3)2 (BD2)100 (BF3)9 (CE4)20,85 (CF3)5 (CF4)17,21,26,55,103 (CF5)1,2 (FP6)9 (FR3)0 (FS3)3,4 (GD3)92 gr. 95 (JD2)16,21 (JG1)13 gr. 12 (JG2)173 gr. 171 (TG5)73,109 (ZH5)42 (BF2)32	1 2 67 92 110 25 92 94 106 110 92 94 110	200 1112 5	825ER 820ER 820IR 822R 822CR 825ER 910 RBRIE 820IR 910 RBRE RBR RBRIE 825EBL 910 RBR TOP RBRE RBRI RBRIE 910 RBRIE 820IR 820ER 822R 825EBG RBR TOP RBRIE	11-25 18-30	36 182	HM HM WM	
3.7.9	+4811a		110	8	820IR 910 RBRE RBR RBRIE	21	100	HM	complete
3.7.10	+2353	(AB6)11 (AC5)126 (AC6)22 (AD5)41,288 (BF3)30 (CF4)163 (FP7)124 (FQ3)8 (FQ4)113 (FT3)1	67 69 92 92C 94 94C 110	8 1017 1100	825EBL 910 RBR TOP RBRE RBRI RBRIE 910 RBRIE 820IR 820ER 822R 825EBG RBR TOP RBRIE	14-30	548	HM WM	
3.7.10	2887	(AB5)94 (AC5)112 (AD5)224,283 (FQ3)42 (FQ4)48 (FR3)2 (BD2)100 (BF3)9 (CE4)20,85 (CF3)5 (CF4)17,21,26,55,103 (CF5)1,2 (FP6)9 (FR3)0 (FS3)3,4 (GD3)92 gr. 95 (JD2)16,21 (JG1)13 gr. 12 (JG2)173 gr. 171 (TG5)73,109 (ZH5)42	92 92F 110	8	910 RBRIE 820IR 820ER 822R 825EBG RBR TOP RBRIE	17-29	164	HM	
3.7.10	2893	(AB5)94 (AC5)112 (AD5)224,283 (FQ3)42 (FQ4)48 (FR3)2 (BD2)100 (BF3)9 (CE4)20,85 (CF3)5 (CF4)17,21,26,55,103 (CF5)1,2 (FP6)9 (FR3)0 (FS3)3,4 (GD3)92 gr. 95 (JD2)16,21 (JG1)13 gr. 12 (JG2)173 gr. 171 (TG5)73,109 (ZH5)42	67 83 92 94 94C 105C 110	1190 1112 850	820IR 820ER 822R 825EBG RBR TOP RBRIE	(9)16-30 (36)	188	HM WM	(BF3) unfired
3.7.10	2893a		110	8	910 RBRIE 820IR 820ER 822R 825EBG RBR TOP RBRIE	22	5	HM	

Fig. no.	Type	Provenance	Fabric	Dec.	Surface treatment	Dia.	%	Man.	Comments
3.7.10	3393	(AC5)45,50,112 (AD5)248 (CF3)34 (FQ4)64 (FS3)3	69 92 92F 110	8	825EBR RBRIE	25-33	75	HM WM	
3.7.10	+3833	(AC5)116,124,131,146 (AD5)287	110 110F	8 200	NRBRI RBRIE	18-25	206	HM	
3.7.11	2025a	(AC6)22 (BE3)16,20 (CE3)47,98 (CF4)73,88 (FP6)20	25 61 92 94 110	1190 1212	820ER 820IR RBRIE RBRI	14-28	125	HM	
3.7.11	3189	(FT3)22	80	1126		22	4	HM	
3.7.11	3500	(BE3)65 (BF3)11 (CE4)1 (CE5)4 (CF4)31,50 (FQ3)56 (HA2)29 - 39 gr. 40,74 gr. 218,83 gr. 225	5 50 59 69 92 94 110	1112 1190	800E 820IR 910	15-31	83	HM WM	
3.7.11	3910	(AD5)163	110	8		-	100	HM	
3.7.11	4365	(CF3)1 (CF4)20 (CF5)1	67 92C 94	1204	820IP 822P 825EIR W INFILL	22-23	14	HM	
3.7.11	4375	(CE4)4 (HA2)146 gr. 94	8 63	1210 1233	810E	21	8	HM	
3.7.11	4399	(CE4)15,42,48,78 (CF3)2,11,30 (CF4)51,69,104,141,145,163 (JC3)4 (TG5)4,22	92 92C 94 106 110	1112 1164 1190 1202 1204 1212	820IR 820IP 822R 825ER 825EIW	17-34	134	HM WM	white infill
3.7.11	4441	(CF3)49 (CF4)96,101,102,173 (JC2)3,24 (JG2)1,178,202,253,265,266 gr. 175 (TG5)5/4	92 94 106 110	1017	820IP 822R H822R	16-30	98	HM	
3.7.11	4498	(CF4)132	110	1190	820IR	21	11	HM	
3.7.11	4506	(CE4)32,86 (CF4)84,139,163	92 110	1017		18-25	22	HM WM	
3.7.11	4541	(CE4)64 (CF3)2,49 (CF4)100,102 (JD2)2 (JE3)133 (TG5)4,5,4,22	67 69 71 92 94 106 110	1190 1212	820IR 822R 825EIR	17-35	80	HM SW	
3.7.12	4475	(CF3)49 (CF4)20,75,93,97,101,159 (JD3)2 (JF1)24 (23)(JH3)57 gr. 36 (TG5)12	92 94 106 110	1017	820ER 825ER 825EGR 910	17-25	115	HM WM	
3.7.12	4542	(BE2)1 (BE4)9 (CE4)64 (CF4)174	83 92 110	8 1007 1017		18-26	34	HM	
3.7.12	4562	(CE4)61,86 (CF3)49 (CF4)102,112,145,161,165 (JG1)35 gr. 31	106 110	1017	910	15-26	192	HM	
3.7.12	+4574	(CF3)36 (CF4)166	94 110	8 1017	825EBR	26	80	HM	
3.7.12	4577	(CF4)159	110	8		22	97	HM	
3.7.12	4625	(CF4)123	110	8 1017		22,4- 23,5	100	HM	
3.7.12	4648	(CF3)74	110	8 1017		25	36	HM	
3.7.13	2207	(AB5)20 (AC6)22 (BE2)67 (BE3)27 (BE4)14,19 (CE4)1	8 12 66 67 92	1012		20-26	70	HM	
3.7.13	2210	(AD5)1,41 (BE3)16 (BE4)14 (CE4)1	67 92 94	1012	830EY CRR RBRE	17-43	67	HM WM	
3.7.13	2238	(AB5)1 (BE3)10 (BE4)19,37 (BF1)9,11,47 (CE4)1 (FS3)1	67 69 71 92 94	36g 1012	820IW	26-39	111	HM WM	
3.7.13	2352	(BE3)104	67	1012	820ER	29	80	-	
3.7.13	3116	(CE5)1 (CF4)88 (ZH5)37	94 110	1012 1094	825ER 910	21-28 (35)	46	HM	
3.7.13	+3128	(ZH5)15,45,48	94	1012 1094	820ER 825ER	20	97	HM	898

Fig. no.	Type	Provenance	Fabric	Dec.	Surface treatment	Dia.	%	Man.	Comments
3.7.13	4366	(CE4)1,15 (CF3)1	69 94 110	1012 lug		19-30	20	HM	
3.7.13	4418	(CF3)24	94	1012 1031		35	7	HM	
3.7.14	2143	(AD5)288 (BE2)1,73 (BE3)27 (CF4)31 (FQ4)3,35 (FR3)22	2 67 69 80 92 110	1002	910 CRR	14-34	56	HM WM	(FQ4)3 from brick
3.7.14	2467	(AD5)262 (BE3)10	20 69			15-23	21	HM	
3.7.14	3191	(CE4)11 (FT3)44	94 94F		H820ER	11-12	42	WM	
3.7.14	3540	(JE3)1	45	brush strokes		24	15	HM	
3.7.14	3547	(BF3)58 (JE3)13 gr. 69	92 112			18-22	7	WM	
3.7.14	3580	(JE3)41 P2	-			26	0	HM	
3.7.14	3581	(CF3)8 (CF4)1 (JE3)43 P3	69 92		820IBR 822R	19-33	16	HM	
3.7.14	4293	(CE4)2 (TG5)13	67 92		910	25-45	10	HM	
3.7.14	4307	(FP7)18 (TG5)29	94 110		822R 910	14-20	22	HM WM	
3.7.14	4406	(CF3)2 (CF4)133	69 92		820EBL	16-18	13	HM WM	
3.7.14	4484	(CF4)113 (TG5)5/4	92			12-35	12	HM	
3.7.14	4513	(CE4)71	92C			22	6	HM	
3.7.14	4522	(CE5)6	92		820EP	11	6	WM	
3.7.14	4538	(CE4)85 (FT3)- (JD2)1 (JF1)24 gr. 23	61 67 92 105 110	lug	822R	10-35	24	HM	(FT3) from brick
3.7.15	2000b	(AD5)227 (BE2)10 (BF2)1 (CF4)20,112 (FO6)34 (FR3)14 (FS3)3 (JD2)51	92 110		820IR 825EP 910 RBRIE	19-34	80	HM	
3.7.15	2022c	(AB4)1,6,14,23,32,91,94 (AB6)1,7,11 (AC5)1,8,33,39,116,117 (AC6)16,20,22,31 (AD5)7,41,87,90,134,161A,167,206,215,219,227,232 (AD6)5 (BC2)2 (BC4)2 (BD2)23,96 (BD3)9 (BD4)8,17 (BE1)6,8,13,18,80,87 (BE2)1,12,19,25,31,32,43,51,67,71,103,104,109,110,114,147 (BE3)9,10,17,18,20,33,37,53,55,56,57,78,106,132,136 (BE4)9,11,14,19,20,48 (BF1)6,13,35,56,57,70,73 (BF2)1,11,15,16,31,33,38,39,40 (BF3)1,8,23,38,50,52,59 (CF3)1,13 (CF4)21 (FO7)39(FP6)56 (FP7)2 (FQ3)8,59 (FR3)1 (JD2)43 (JG2)1,164 (TG5)12,100 (ZH5)15,36,45	1 2 9 11 12 17 22 25 25L 56 61 65 66 67 69 83 92 94 94F 95 106 110 110F	1204 870 x 1	810I 816 H820ER 820ER 822R 825EBR 825ER 825EIR 832ECR 832EP 832ER 834ER 834EIR 910 CRR RBR TOP RBRIE RBRI	12-36	1781	HM SW WM	sooty exterior
3.7.15	2050	(AB4)10,11,23 (AB5)29,41B,59,86 (AB6)8 (AC5)0,12,34 (AC6)1,22 (AD5)67,123,273,278,289 (BD2)24,49,61,94 (BD3)4,16,32 (BE1)8,26,41,49,61 (BE2)10,21,24,32,33,37,48,50,52,60,68,70,71,78,100,103,105,110,116,117,145 (BE3)1,10,16,18,27,31,37,44,55,56,63,67,70,71,78,106 (BE4)9,19,20,37,60 (BF1)4,6,11,16,27,53,56 (BF2)2,31,56 (BF3)7,8,9,21,23,24,50,52 (CE4)53 (CF3)2 (CF4)50,56,96 (FO6)19 (FO7)65 (FP7)142,160 (FQ4)26 (FR3)1 (FS3)1,2,11,14,16 (FT3)1,2 (TG5)4,9,12,46 (ZH5)15,44	1 2 25 61 67 69 80 89 92 93 94 95 110	1017 1112	810I 810/805E 820ER 820IR 822R 825ECR 825ER 820EW 825EIR 830ER 830EO 910 RBRE RBRI RBRIE	(7-8) 11-36	2577	HM WM SW	
3.7.15	2124b	1075 12 (BE2)37,48 (BE3)16 (BE4)19 (ZH5)37	1 12 67 69 92 94	5 1112 lug	910	18-27	79	HM	

Fig. no.	Type	Provenance	Fabric	Dec.	Surface treatment	Dia.	%	Man.	Comments
3.7.15	2214	(AB5)338 (BE3)64 (FN6)3,9	94 110	8	910 NRBR	23-35	47	HM	
3.7.15	2216	(BE2)37 (BE3)10 (BE4)9	61 65 67	1112 lug on rim	820ER	16-25	29	HM WM	
3.7.15	2246	(BE3)78 (TG5)77	2 94			17-25	17	HM WM	
3.7.15	2329	(AB4)23 (AB5)233 (AB6)7,8,9,24 (AC5)13,34,51 (AC6)1,17,18,23,30,33,34,40,54,268,304 (AD6)16 (BC4)1,2 (BD2)28,50,100 (BD3)8,9,14,16 (BE1)6,9,49,63 (BE3)10,16,21 (BE4)13 (BF1)2,4,16,30,53,57 (BF2)56 (CE4)1,47,98 (CF4)57,101,113 (FN6)3 (FO6)1,90,93,114 (FP7)72 (FQ4)61 (FR3)2 (FT3)9 (JE2)1 (TG5)127	2 11 65 67 69 92 94 106 110	850 oblique parallel lines	820ER 820IR 822R 825IR 825EIR 910 RBRIE	11-37	1170	HM WM	
3.7.15	2340	(AB6)11 (BE2)67,110,128 (BE3)10,57 (BE4)8,14 (BF1)6,44,75 (BF3)58 (CE4)2,48,85 (CF4)73,113 (FS3)11 (FZ1)10 (JG2)206 gr. 150	12 17 65 67 69 92 94 110 110L	200 1017 850 x 1	820EP 820ER 822R 910	15-27 (39)	260	HM	
3.7.15	2343	(AB5)10,23,33 (AB5)58,59,66,72,229 (AC5)34 (AC6)14,22,27,36 (AD5)1,16,1225 (AD6)5 (BC4)2 (BD2)28,50,61,82 (BD3)8 (BD4)17 (BE1)44 (BE2)10,43,67,71,103,160 (BE3)10,16,27 (BE4)1,19,20 (BF1)2,4,11,13,16,28,30,44,45,56,72,73 (BF2)32,38 (CE4)1,2,48,58,85,98 (CE5)1 (CF3)1 (CF4)1,13,20,55,75,88,107,108,163 (FO6)61,91 (FO7)44,68 (FQ4)20 (JC3)16 gr. 12 (JD3)1 (JG2)1 (TG5)5,4,9,12,73,94,100,115,137 (ZH5)37	1 2 32 65 66 67 67L 69 80 92 92F 93 94 94F 106 110	5 1112 1119 1190 1202 1203	820ER 820IR 822R 825ER 825EIR 910 CRR RBRIE	14-30 (35-40)	1541	HM WM	
3.7.15	2457	(AB4)10,23 (AB5)1 (AC6)1 (AD5)1,88 (BC4)2 (BD2)28,32,40 (BD4)17 (BE1)7,80 (BE2)9,37,48,51,117,158 (BE3)26 (BF1)16,70 (BF2)56 (CE4)2 (CF4)7 (FP6)138,156 (FR3)12	1 11 67 69 92 92F 94 110		910 RBRE faint ribbing	14-33	450	HM WM SW	
3.7.15	2516	(BE2)87,156 (BE3)10 (BF1)4	25 69 80 94		820EW 825E	10-25	42	HM WM	
3.7.15	+3003	(BD3)12 (BE2)37 (CE4)48	19 67 94		820ER 820IGR	6-25	26	HM WM	
3.7.15	4377	(AB5)231 (BF3)8 (CF3)1 (CF4)18 (FQ3)43 (CF3)13 (CF4)17,30,50	56 65 80 92	850	822R 822W	18-30	123	HM WM	
3.7.16	220	(BE3)22,63,55 (BE4)14 (CE4)1 (TG5)154	110	1190 1212		23-32	52	HM	
3.7.16	2239	(AB4)31 (AB5)298 (AD5)1,167 (BE4)19 (BE2)51,56 (CF4)75 (FS3)1 (FT3)2	2 56 67 69 92 94 1 67 69 71 92 94 94C	850 appliqué on rim?	CRR	21-40 18-60	39 88	HM	
3.7.16	2256	(AB5)29,59,263 (AC5)73 (BE3)10,27,49 (BD2)3,47 (BE4)60 (CE4)1 (FP6)3 (FQ4)23 (FT3)12,44	8 67 71 92 94	245g 246g 1010 1063 850	820IR 830IR 910	23-50	116	HM WM	(AB5)59 unfired
3.7.16	2422	(AB5)302 (BE1)73 (BE3)55 (BE4)19 (CF4)17 (TG5)57	25 69 80 92 94L		825ER 825EIW	20-35	49	HM WM	
3.7.16	3490	(AD5)136 (CE4)1,2,4,20,86 (CE5)1 (CF3)1, (CF4)1,17,30,31,35,50,51,56,88,96 (CF5)1 (FQ3)42 (JG2)182,183 gr. 150	56 67 92 94 105 110 111 122	1017 1190 1195 1209 1212	820IW 820IR 822R 825EIBR	16-30	224	HM WM SW	(FQ3) from brick
3.7.16	4466	(BE4)11 (CF3)49 (CF4)65,88,113 (FP6)136	67 94 95 110	1097 1190	H822R 825IR 830ER	17-35	37	HM	

Fig. no.	Type	Provenance	Fabric	Dec.	Surface treatment	Dia.	%	Man.	Comments
3.7.16	4488	(CE5)4 (CF4)69 (TG5)5/4	67 94		820IW	24-26	27	HM WM	
3.7.16	+4535	(CE4)65 (JE3)1	20 94	1190 1238	820IR	34.5	60	HM	(JE3) B only
3.7.16	4624	(BE3)1 (CF4)117	94 110	1190 1254	H820IR	30	107	HM	
3.7.17	91	(BF2)1,31	66			19-22	31	HM	
3.7.17	2255	(BE2)43 (FQ3)41	1 34			21-28	14	HM WM	(FQ3) from brick
3.7.17	2263	(AD5)134 (BE2)37 (BE3)1 (FR3)3	67 94 110		RBRE	10-30	21	HM	
3.7.17	2296	(BE3)118 (BE4)82	1	1016 1017		18-25	17	HM	
3.7.17	2302	(BE3)106 (BF3)40 (TG5)12	2 92 94	850		26-37	46	HM	
3.7.17	2414	(BE3)1	67			35	8	WM	
3.7.17	2455	(BE3)18 (BF2)51	67	1038	822R	36	8	HM	
3.7.17	2933	(AB4)31 (AD5)236 (CF4)65 (FR3)12,15 (FS3)6	92 92C 93 110		825EIO 910 RBR	25-40	33	HM WM	
3.7.17	3355	(AC5)167 (AD6)13	65 83		825EBL	25-36	15	WM	
3.7.17	3680	(TG5)1,18,42,46	67 92 105	1190	820ER	22-30	21	HM WM	
3.7.17	3781	(AD5)207	92F		820IW	22	6	HM	
3.7.17	4473	(CE4)9	110	1228	RBR TOP	26	11	HM	
3.7.18	182	(AC6)22 (BE3)9,10,78 (BF2)1,16 (CE4)1,20 (CF3)1 (CF4)1 (FQ4)27 (TG5)5/4,94	1 67 69 92 110		925ECR 825IW 910	23-33	114	HM WM	
3.7.18	2037	(AB4)11,33 (AB5)1,65 (AD5)134,160 (AD6)4 (BF2)15 (FQ4)7 (TG5)1	12 67 69 81 92 94		825EIO 825EI	11-35	113	HM WM	
3.7.18	2061	(BC4)1 (BD2)45 (BE3)116 (BF2)31,39,56 (BF3)8,38 (FP6)34 (TG5)117	61 65 80 92 94 110	850 871	820 825ER RBRIE	11-40	128	HM WM	
3.7.18	2086	(BF2)1	-			56	0	-	
3.7.18	2152	(BE3)55 (BE4)14 (BF3)9	1 67			24-27	21	HM	
3.7.18	2217	(AB5)42 (AB6)9 (AC5)1,13,129 (AC6)4 (AD5)112,160,161A (AD6)5 (BD2)27,47,71 (BD3)16 (BE2)78 (BE3)37,64 (CE4)4,86 (CE5)1 (TG5)4	19 65 67 69 80 92 93 94 94F 110		822BL 822R 825EIR 825EJW 910	9-33	255	HM WM	
3.7.18	2225	(AB4)22 (AB5)3 (AC6)30 (BD2)40,101 (BE3)27,78 (BF1)6 (BF2)56 (BF3)17 (CE4)20 (FO6)53 (TG5)1,9	67 69 80 83 92 94 110		825EP 825EIR 825EIW	12-34	112	HM WM SW	(BD2)101 waster
3.7.18	2264	(AB4)10 (AC5)37,49 (AC6)36 (AD5)141,206 (BE1)73 (BE2)10,32,33,48 (BE3)17,55,78 (BF1)1,16 (BF3)38	1 2 61 65 67 69 93 94	870 x 1	825EIBL 825EIP 825EIR	13-35	211	HM WM	
3.7.18	2271	(AB5)66,207 (BE3)16,55 (FT3)22 (TG5)1	25 67 69 77		822R	13-42	53	HM WM	
3.7.18	2276	(BE3)10,55	1 67			14-31	15	HM	
3.7.18	2346	(BE2)43 (FQ3)40	89 92			22	6	WM	(FQ3) from brick
3.7.18	2449	(AD5)112 (BE3)18	67			28-40	20	WM	

Fig. no.	Type	Provenance	Fabric	Dec.	Surface treatment	Dia.	%	Man.	Comments
3.7.18	2461	(AD5)160 (BE3)10 (CE4)37 (FS3)4,13 (TG5)1,74 (BE3)16	69 81 92L 94 94C 110		825EW	18-37	39	HM WM	
3.7.18	2479	(AC6)22 (AD5)134 (BE2)51 (BE3)146 (CF4)100 (FR3)12,15,17 (FS3)11 (FT3)1	32			25	8	WM	
3.7.18	2535	(AB4)1 (AC5)46 (AD5)168 (CF4)17 (TG5)5/4 (BE2)78 (BF2)51 (FQ4)37	67 69 71 92 94 110		910 RBRE	13-48	59	HM WM	
3.7.18	2553	(BE2)145 (BE3)16,56,104 (BE4)9,14 (BF1)56 (FP7)155 (FS3)11 (BE2)32	81 92 94 110		825EI	20-27	29	HM WM	
3.7.18	2558	(AB4)1 (AD5)198 (BD4)17 (BE3)10,16,18,55 (BF1)4 (CF3)8 (FR3)2 (TG5)102-105	9 92 110			24-60	14	HM	
3.7.19	2206	(AB5)89 (CF5)2 (AB5)207 (AD5)157 (AD5)160	67 69 92 110		820IR 910 RBR TOP	22-53	69	HM WM	
3.7.19	2278	(AC5)112 (AD5)289 (CE4)37 (CF3)1 (CF4)1,21,65 (CE5)1 (FP7)21 (FQ3)48 (FQ4)23	92			30	8	WM	
3.7.19	2284	(AC5)93 (AD5)248,272 (BE3)106 (FS3)11 (FT3)49 (TG5)1,74 (TG5)87	2 8 67 69 80 92C 94		820IR 820EW 825EIBR 825EIW 910	17-30	232	HM WM SW	
3.7.19	2612	(CF4)1 (CF5)1 (FO6)60 (TG5)1,73 (CF4)21 (TG5)73 (TG5)95	92		822R 822W	24-26	10	HM WM	
3.7.19	2870	(AC5)93 (AD5)248,272 (BE3)106 (FS3)11 (FT3)49 (TG5)1,74 (TG5)87	9		825ER	28	16	WM	
3.7.19	3283	(AC5)112 (AD5)289 (CE4)37 (CF3)1 (CF4)1,21,65 (CE5)1 (FP7)21 (FQ3)48 (FQ4)23	25		825EW	30	7	WM	
3.7.19	3353	(AC5)93 (AD5)248,272 (BE3)106 (FS3)11 (FT3)49 (TG5)1,74 (TG5)87	94	1000 scar?		37	10	WM	
3.7.19	3438	(AC5)93 (AD5)248,272 (BE3)106 (FS3)11 (FT3)49 (TG5)1,74 (TG5)87	67 92 94 105 110		820EW RBR TOP	20-43	76	HM WM	
3.7.19	3438a	(AC5)93 (AD5)248,272 (BE3)106 (FS3)11 (FT3)49 (TG5)1,74 (TG5)87	69 92 110	87g 1112	820IR 822BR RBR TOP	22-43	43	HM WM	
3.7.19	3555	(AC5)93 (AD5)248,272 (BE3)106 (FS3)11 (FT3)49 (TG5)1,74 (TG5)87	94		832R/ 825EIW	23-32	27	WM	(FT3) from brick
3.7.19	4074	(AC5)93 (AD5)248,272 (BE3)106 (FS3)11 (FT3)49 (TG5)1,74 (TG5)87	94F			24	34	WM	
3.7.19	4079	(AC5)93 (AD5)248,272 (BE3)106 (FS3)11 (FT3)49 (TG5)1,74 (TG5)87	67 94 110			17-27	56	HM WM	
3.7.19	4080	(AC5)93 (AD5)248,272 (BE3)106 (FS3)11 (FT3)49 (TG5)1,74 (TG5)87	67 92		822P 825ER RBR	25-40	29	WM	
3.7.19	4202	(AC5)93 (AD5)248,272 (BE3)106 (FS3)11 (FT3)49 (TG5)1,74 (TG5)87	-			31	0	WM	
3.7.20	1013	(AB6)8 (AD5)0 (BE2)31 (BF3)28,50 (FP6)171 (TG5)1,44,79,87 (AD6)5 (BE3)59,78	1 2 25 65 67 69 94 94L 110	850	825EIBR 825EIR RBR TOP	22-46	67	HM WM	
3.7.20	2245	(BE2)51 (BE3)13 (BE4)19 (BE2)110 (FS3)1 (HA2)1	67 80 94		825EIR RBR	15-23	23	WM	
3.7.20	2298	(BE2)51 (BE3)13 (BE4)19 (BE2)110 (FS3)1 (HA2)1	25 65 94		820IR	23-26	21	HM WM	
3.7.20	2327	(BE2)51 (BE3)13 (BE4)19 (BE2)110 (FS3)1 (HA2)1	67 69		822R	19-22	23	WM	
3.7.20	2468	(AB4)7,10,23 (AC6)22 (AD5)161A,227 (BD2)45 (BE1)41 (BE2)67 (BE3)10 (CE4)1 (CF4)65 (FN6)6 (TG5)74,87,94	25 67 69 71 92 92C 94 110		910 RBR TOP	12-48	165	HM WM SW	
3.7.20	2589	(AB5)68 (AC5)107 (AD6)14 (CE4)4 (FQ3)8	67 69 92 110		825IR RBR TOP	22-34	55	HM WM	

Fig. no.	Type	Provenance	Fabric	Dec.	Surface treatment	Dia.	%	Man.	Comments
3.7.20	2599	(AB4)11,23 (AB5)52,58,80,233,255 (FS3)2	69 92		820ER 825EW	13-20	142	HM WM	
3.7.20	2604	(AB5)50 (AD5)34,117 (FP7)12 (FR3)23 (GD3)139 gr. 138 (HA2)74 gr. 218 (TG5)94	67 92 100 110		820ER 910 RBR TOP	15-37	39	HM WM	
3.7.20	2827	(AC5)108,124 (AC6)22,61 (AD5)161A,219 (CF4)17 (FP6)40 (FQ4)61 (FR3)0 (FR4)1 (FS3)3,14 (FT3)1 (TG5)29	65 67 69 92 92C 110		820IW 910 RBR TOP	10-40	78	HM WM	(FP6) oil stained
3.7.20	2872	(AB5)211 (TG5)4	65 110			40	9	HM WM	
3.7.20	2879	(AB5)225 (FQ4)37 (FR4)1,7,9	1 92 110		910 RBRIE	17-35	53	HM WM	
3.7.20	2954	(AB4)23 (AC5)112 (FQ/R4)2,(FR4)2 (TG5)73,87	69 94 110		RBR TOP	18-27	16	HM WM	
3.7.20	2969	(AB4)23 (FR3)2	69 92		820EIW 910 RBR TOP	25-34	33	HM WM	1 deformed
3.7.20	3167	(CF4)96 (FT3)2	83 92			20-21	12	WM	
3.7.20	3174	(CE4)37,58,86 (CF3)41 (CF4)18,51 (FR3)1 (TG5)7	67 92 92F 94 110		RBRIE	18-30	39	HM SW	
3.7.20	3227	(AD5)54,80,112 (AD6)13 (CE4)4,48,85 (CE5)6 (CF4)88 (FQ4)67 (TG5)65	22 67 92 105 110			16-35	104	HM WM	
3.7.20	3362	(AD5)185 (CF4)20	80 94C		825ER 825EIW	32-33	26	HM WM	
3.7.20	3488	(AD5)198	94			22	7	WM	
3.7.20	3509	(HA2)79 gr. 188	106		822R	30	5	WM	
3.7.20	3604	(TG5)22	-			16	-	WM	
3.7.20	3619	(HA2)74,250 gr. 67	102			17	17	WM	
3.7.20	3650	(CE5)1 (CF5)2 (TG5)18	67 92 110			15-30	26	HM WM	
3.7.20	3903	(FR4)7	110		RBR TOP	23-27	13	HM WM	
3.7.20	3907	(FR4)1	94	932E	825EIR	16	3	WM	
3.7.20	4047	(TG5)91	94			28	7	WM	
3.7.20	4311	(TG5)1,74	67 94		825EICR	20	7	WM	
3.7.20	4403	(CF3)8	94		820EP 820IBR 830EBR	16	11	WM	
3.7.20	4461	(CF4)17	92		H822R	23	6	HM	
3.7.20	4472	(CE4)9,14	110		910 RBR	19-24	28	HM	
3.7.20	4481	(CF4)65	92		822R	28	6	WM	
3.7.20	4554	(CE4)48	92F		822P	25	5	WM	
3.7.20	4614	(TG5)4	94		820EW	12	6	WM	

Fig. no.	Type	Provenance	Fabric	Dec.	Surface treatment	Dia.	%	Man.	Comments
3.7.21	230	(AC5)127 (AD5)161A 217 (BE1)9 (BE3)10,16,18,27,37,49,50,56,63,78,106 (BE4)8,19 (BF1)30,56 (BF2)31 (BF3)13 (FP6)155 (FP7)10,12 (FQ3)8 (FR3)0 (FS3)4 (JF1)16	1 2 8 9 65 67 69 89 92 94 95 106 110		910 RBR TOP	13-39	233	HM WM	
3.7.21	230a	(BE3)10	67	40g		40	8	HM	
3.7.21	2033	(BF2)8	92			20	5	WM	
3.7.21	2041	(BE2)1 (CE4)11	69 110	831E		15-30	20	HM WM	
3.7.21	2051	(BE2)21 (BE3)65 (BF2)31 (CE4)71 (TG5)18	67 69 80 110	832R	830R RBRI	15-27	34	HM WM	
3.7.21	2101	(BF3)56 (JD2)43 gr. 40	69 105		832W	17-24	10	WM	
3.7.21	2103	(AB4)11 (AB5)4,233 (AB6)13 (AC5)117 (AD5)168,272 (AD6)16 (BE4)8,9 (CE4)2 (CF4)65,112 (FO7)73 (FP6)5 (FP7)12 (FQ4)7,23,35,63 (FS3)1	11 67 69 92 94 110		820IR 910 RBR TOP	15-35	254	HM WM	
3.7.21	2154	(BF3)9 (TG5)6	92			17-30	9	HM	
3.7.21	2175	(AC5)99 (AD5)241 (AD6)13 (BE1)1,7,22,63 (BE3)10,16,18,67 (BE4)9,14,19,29 (BF1)6,45 (BF2)31,51 (CE4)1,71,86 (CF4)1,88,111 (FS3)13 (TG5)4,5/4,6,7,9,29-105	1 2 11 45 67 69 92 92C 94 110	55g 57g 151g	910 RBR TOP	18-50	289	HM WM SW	some sooty
3.7.21	2228	(AC6)40 (AD6)12 (BE2)43 (BE3)10,16,18,55 (BE4)14 (FO6)53	1 11 67 69 92 94		RBR TOP	17-35	90	HM SW	
3.7.21	2247	(AB4)10,23 (AB5)89 (AD5)67,161A (BC4)1,2 (BD2)45 (BE1)1 (BE2)26,73,133 (BE3)16,55,57,78 (BF1)2,16,30 (BF2)15 (CE4)1 (CF4)21 (FO7)68 (FS3)1 (TG5)1,29-105	1 2 21 67 69 71 80 92 94 94L 110	1115	822R 825IR 910 RBRIE	18-36 (45)	272	HM WM	
3.7.21	2252	(AD5)278 (BD2)63 (BE3)78	67 80 110	lug	820ICR	26-33	17	WM	
3.7.21	2291	(AB4)1,7,23,32 (AB5)1,41B,239 (AB6)11 (AC6)22 (AD5)227,249,256 (BD2)50 (BD3)16 (BE2)133,158 (BE4)42 (BF2)51 (CF4)162 (FP6)61 (FQ3)9 (FR4)2 (FS3)6 (FT3)4 (FZ1)9 (TG5)74,75,116	65 67 69 92 94 110 110F	850	820IR 822R RBRIE	15-29	269	HM WM	
3.7.21	2321a	(AD5)167,283 (BE4)9 (FR3)2 (TG5)132	69 110		820IR 910 RBR TOP	19-33	30	HM WM	
3.7.21	2409	(AB5)91,94 (BE2)24 (CF3)5 (TG5)7	65 69 94		800I 825ER 910	16-27	26	HM WM SW	
3.7.21	2421	(AB4)6,10 (AB5)32 (AC5)59 (AC6)34 (BD2)95 (BD4)8 (BE1)63 (BE2)71 (BE4)19 (FQ4)59 (HA2)217 gr. 267	1 67 69 92 94		820IR 825IR RBR TOP	12-27	92	HM WM SW	
3.7.21	2507	(AB4)7 (AB5)20 (AB6)1 (BD2)82,101 (BD3)1 (BE1)9,80 (BF1)4,11,16 (BF2)56 (CE4)1 (CF4)1,107 (FQ4)2 (FT3)1 (TG5)46,73	1 2 11 67 69 83 92 94 110		820IW 822O 825IR 910 RBRIE	14-34	129	HM WM	
3.7.21	2528	(AD5)1 (BD2)24 (BE2)48	1 69 80		820IO 825EIR	17-33	26	WM	
3.7.21	2532	(AB4)6 (AB5)58,67 (AB6)7,8,27 (AC5)33,49,77 (AD5)34 (AD6)5 (FQ3)58 (FQ4)6 (FR4)2	69 89 92 110		820I 910 RBRIE	16-23	237	HM WM	
3.7.21	2537	1066 4 (AB4)7 (BE2)68 (CE4)1,11 (CF3)49 (CF4) 51,155,161 (FO6)125 (FQ3)61 (FZ2)50 (TG5)5/4,7,102	1 8 11 67 92 92C 94 105 110 110C		820IR 910 RBR TOP	14-34	146	HM WM	(FO6) appliqué on rim?

Fig. no.	Type	Provenance	Fabric	Dec.	Surface treatment	Dia.	%	Man.	Comments
3.7.21	2590	(AB5)68 (AC5)34 (AD5)1,87,162, 219 (CF4)132 (FO6)109 (FP7)19 (FQ4)7 (FR3)14 (FS3)1,6	1 69 92 94 110	1112	825IBR 825EIW 910 CRR RBRIE	10-28	182	HM WM	
3.7.21	2634	(AB4)11,23 (AB5)65 (AD5)1 (FT3)1 (TG5)91	1 92 94	1112	822R 910 CRR RBRIE	12-20	145	HM WM	
3.7.21	3476	(AD5)203 (AC5)102 (CE4)1	67 92 110		910 RBR TOP	23-30	26	HM WM	
3.7.21	3507	(HA2)79 gr. 188	69		820R	24	4	WM	
3.7.21	3534	(FT3)15,18 (HA2)83 gr. 84 (TG5)18	5 67 92			16-36	18	HM	
3.7.21	3560	(JE3)2	92			22	3	HM	
3.7.21	3598	(TG5)22	-			34	-	-	
3.7.21	3600	(TG5)22,29	67			19-29	8	WM	
3.7.21	3601	(TG5)22,29	106			20	8	WM	
3.7.21	3660	(FP6)111 (TG5)18	93		RBR TOP	25	3	HM	
3.7.21	3663	(TG5)18,65	67 92			30	6	WM	
3.7.21	4204	(BE3)55 (BF3)8 (TG5)65,95	1 69 92			15-27	19	HM	
3.7.21	4208	(TG5)96	-			21	0	-	
3.7.21	4268	(CF4)88 (TG5)132	92 94		822R	16-19	15	HM	
3.7.21	4421	(BF2)31 (TG5)6	67 92			22-34	11	WM	
3.7.22	2062	(AB4)23 (BE1)6,63 (BE2)153,158 (BE3)10,16,18,106 (BE4)14,42 (BF1)6,28,56 (BF2)39 (FQ3)59 (FQ/R4)2 (TG5)1,9,29,29-105	1 67 71 92 94 110		910 RBRE	16-33	173	HM WM	
3.7.22	2132	(AD5)204 (BE1)1 (BE3)16 (BE4)11 (BF1)56	1 45 56 69 80 110	1036	800E 822R	15-30	105	HM WM	
3.7.22	2135	(BE3)55 (BF1)56 (BF2)37	1 67			22-33	23	HM	
3.7.22	2146	(BE1)80 (BE2)32 (BE3)16,18,70,132 (BF1)72 (FQ3)59	11 67 69 76 92			17-34	34	HM WM	
3.7.22	2197	(AC5)164 (BE1)49 (BF1)9 (BF3)8 (FS3)3	1 67 110		910	23-35	26	HM WM	
3.7.22	2294	(BE1)8,9 (BE4)9,42 (BF1)4,6,9,13,16,33,56,72,73 (CE4)2 (FR3)15 (TG5)4,6,29	1 11 67 67Q 75 94 110			15-35	235	HM WM	
3.7.22	2406	(AD6)5 (BE3)26 (BF1)2,35 (FQ4)7	67 71F 92		822R 825EIW	19-30	36	HM WM	
3.7.22	2439	(AD5)87,198 (BE2)128 (BF1)9,33 (FQ3)63 (TG5)29	2 67 92 94 105	850		19-33	44	HM WM	
3.7.22	2518	(AC5)57 (BE1)85 (BF1)9,35 (FO7)73 R18 -	45 69 92 94 110	1142	8223 825EIR RBRIE	16-24	48	HM WM	
3.7.22	2760	BC 2 (BF2)56 (CF5)1	25 67 110			18-25	21	HM	
3.7.22	3458	(FQ4)8,66 (FR3)13 (TG5)29	67 110		910	23-28	30	HM WM	
3.7.22	3613	(HA2)175 gr. 94	63	200		-	0	HM	
3.7.22	3673	(CF3)49 (TG5)12,64	110			16-23	14	HM	

Fig. no.	Type	Provenance	Fabric	Dec.	Surface treatment	Dia.	%	Man.	Comments
3.7.22	3980	(FQ3)42	80	1166		17	9	WM	
3.7.22	4758	(FO7)77	110	200		33	12	HM	
3.7.23	2043	(BF2)15,31 (BF3)9,13 (JD2)18 (JD3)1	67 69 75 105		805EI	20-26	40	HM WM	
3.7.23	2088	(AB5)1 (AC5)37 (BD2)47 (BE1)44,63 (BE2)71 (BE3)1,10,16 (BF1)56 (BF2)31,37 (BF3)1 (CE4)2 (CF3)1 (CF4)101 (JC2)3 (TG5)1,65 (ZH5)53	2 8 25 65 67 69 76 92 93 94 105 110	850	820ER 820IR 822R 910	18-45	224	HM WM	1 deformed
3.7.23	2169	(AB5)32,68 (AC5)1 (BE2)70 (BE3)10,16,55 (BE4)12 (BF1)16,31 (BF2)31 (BF3)17,50 (CE5)6 (CF4)99 (HA2)45 - (TG5)46,102 (ZH5)82	2 25 65 67 69 80 83 92 95	850 931E 1204	820IR 822P 822R 822W 830EW	13-37	236	HM WM	
3.7.23	2279	(AB5)32 (AD5)283 (BE3)56 (BF1)56 (CE4)1 (CF3)5 (FR4)9 (TG5)1	11 33 67 69 91 92 110		820EO 825ER 825IR 910	20-40 (55)	41	HM WM	
3.7.23	2667	(AB4)10 (AC6)59 (CF3)2 (FQ4)61	92 94 94F		822W	18-30	62	HM WM	
3.7.23	2676	(AB4)10,11,23 (AB5)231,233 (AC5)21 (AD5)1 (TG5)1,1,12	2 67 69 92 94F 106		825EIW 910 RBRIE	20-38 (52)	92	HM WM	
3.7.23	2860	(BD2)99 (CE4)1,86 (CF3)26 (CF4)13 (FS3)3	67 71 92 106 110	1012		25-37 (60)	32	HM WM	
3.7.23	3106	(AB5)290 (JE2)15 (TG5)29,74 (ZH5)36	67 92 110		820IR	20-30	24	HM WM	
3.7.23	3325	(AD5)102 (CF3)1 (CF4)17 (TG5)1S	67 92		825EIR	22-37	47	HM WM	
3.7.23	3677	(TG5)46	-			22	-	WM	
3.7.23	3780	(AD5)207	126		H820EO	23	6	WM	
3.7.23	3904	(CF4)51 (FO6)66 (FQ4)88	110 116		825EIGR RBR TOP	18-32	20	HM	
3.7.23	4453	(CE4)20,47	67 94		822Y	27-40	9	HM WM	
3.7.23	4527	(CF3)22	94		822P	28	8	WM	
3.7.23	4566	(CF4)155,161	94	176g	822W	25-30	26	WM	
3.7.23	4594	(CF3)49	94L		822BL	22	9	WM	
3.7.24	2201	(BE2)158 (BF3)8	67 69		820EW 830ERW	12-22	20	WM	
3.7.24	3036	(ZH5)29	-			18	-	-	
3.7.24	3554	(FT3)49 (TG5)46	92 110			30-35	26	WM	
3.7.24	3582	(JE3)72 -	-		RBRIE	56	-	-	
3.7.24	4171	(FP6)1	71			30	7	HM CB	
3.7.24	+4561	(CF4)145,161	94			27-30	45	WM	
3.7.24	4582	(CF4)99	92			27	17	WM	
3.7.24	4763	(JE2)26 gr. 14	105		822R	51	6	HM	
3.7.24	4821	(JF1)24,26,28 gr. 23	92		822BG	35	12	WM	
3.7.25	2527	(AC6)18,22 (AD6)5 (BC2)2 (BC4)1 (BE2)48,60 (BF1)4 (FQ3)8 (FQ4)21	1 67 69 82 92 94 110	1002	820IR 825EIR RBR TOP	17-48	63	HM	

Fig. no.	Type	Provenance	Fabric	Dec.	Surface treatment	Dia.	%	Man.	Comments
3.7.25	2699	(AB4)11 (AC5)112 (AC6)71 (AD5)1,113,157,161A,276 (CE4)1 (CF4)1,17 (FN6)6 (FO6)15,62,125 (FP6)1,9,37,138 (FP7)55,123 (FQ4)21 (FR3)22 (FS3)2 (TG5)29-105	65 67 69 92 92C 93 94 110	72g 73g	822R 825EIBL 825EIW 910 RBR TOP RBRIE	10-40 (50)	607	HM WM	2 rim notches
3.7.25	2899	(AC6)22 (AD5)54,207,219,227,272 (AD6)5 (CF3)5 (FO6)16,52/62 (FP6)9 (FP7)31 (FR3)0 (FT3)1 (TG5)1,29,74	67 92 92C 110		910 RBR TOP	20-50	238	HM WM	
3.7.25	2921	(AB4)22	67			60+	5	HM	
3.7.25	3027	(CF4)1 (FS3)14 (ZH5)2	92 110	1085		20-28	12	HM	
3.7.25	3095	(AD5)7 (FO6)37 (FP6)9 (FQ4)80	71 92 97 110		910 RBR TOP	30-40	30	HM	
3.7.25	3671	(TG5)4,66	110			21-27	7	HM	
3.7.25	3868	(AD5)298	92		910 RBRE	20	7	HM	
3.7.25	3935	(AC6)22 (FO6)2,89 (FO7)52,69 (FP6)138 (FZ1)25	67 92 110		910 RBR TOP RBRIE	20-37	43	HM WM	
3.7.25	4252	(TG5)112	92		RBRI	20	3	HM	

3.8. Ware 910 and similar vessels

Generally handmade, with a roughly finished body exterior and smoothed rims. This type of coarse pottery is as common as the red-rimmed ware, but occurs in a wider range of forms. No example was found with a thickening of the base, as in 3.7.10 & 3.7.12, for example. Similar vessels have been found at Kerma (Ruffieux 2007) and at Meroe (Nowotnick 2018), and are generally an indicator of Napatan occupation levels, although to some extent the same characteristics (coarseness, and fabric) persist in the early Meroitic (see 3.8.9 and 3.8.10 in particular, open-mouthed jars with lid-seating).

3.8.1 and 3.8.2 Deep coarseware bowls with 'S'-shaped profile

Note the similarity of these forms to those in the RBR ware (3.7.2).

2194x: Nowotnick 2018, fig. 3, 0649.

+3225x: Top of rim at a slightly different angle, Ruffieux 2007, pl. 4.36 [26-11], Nile clay; Napatan.

3241x: Nu.46 (19, 453-423 BC) fig. 144, 18-1-109 red ware (probably Medieval, but similar form to the Napatan one).

3385x: Found upside down, reused as an oven, the broken off part of the rim will have functioned as an air conduit.

4051x: Nowotnick 2018, fig. 3, MRB VU 10-0642.

3.8.3 Crude vessels

Often with a 'crackled' rim (i.e. clay left to dry out before firing without any attempt to smooth the surface), eight examples with one or multiple holes made in or near base before firing, and coarseware miscellaneous bowls.

3.8.4 Deep bowls

Most likely cooking pots with inverted rims bowls with inverted rims.

3.8.5 Coarseware bowls or cooking pots

With vertical sides and plain rims.

3.8.6 Deep everted coarseware medium sized bowls and small cups; roughly hemispherical bowls with beaded rims

See 6.11 for similar forms.

3.8.7 Open coarseware bowls

No specific use is indicated.

3.8.8 Coarseware bowls with decorated beaded rims, everted plain rims and everted flanged rims

Includes the rimless body of a deep storage(?) jar.

3.8.9 Deep coarseware cooking pots

Everted, straight and inverted, with rough lid seating variations. For a complete profile, see +4650x (3.4.11).

4350x: Mohamed Ahmed 1992, fig. 22 I D34c late 7th to mid 6th centuries BC.

3.8.10 Coarseware bowls

With various forms of lid seating.

3.8.11 Miscellaneous bowls or cooking pots with ledge rims

4196x: The two (fragmentary) graffiti found on different examples of this form, both from the same context, are roughly similar, although one was incised (142g) and the other traced with red slip (141g). Possibly the latter is only an accidental dribble, but note 3063x (3.8.13), with a similarly shaped 'dribble'.

3.8.12 Coarseware closed jars

With faint beading or ledge rims. Only one has evidence of handles and lid seating.

3.8.13 Deep coarseware bowls

With vertical sides and internal or external beading.

3063x: the external dribble of red paint could possibly be a variant of graffiti type 141g (and 75g, etc.).

3.8.14 Basins

With appliqués on rim, and similar forms, without. Some are oval rather than round in circumference. The appliqués appear to consist of a snake (2828x, 1068y) and crocodiles (3267x, 1129y) and the tails of others (2458xa, 2567x and 2853x) as well as other even more fragmentary instances. See also 3.9.7 for a more complete crocodile on a different form (3084x).

3.8.15 Deep coarseware bowls and basins

With beaded, ledge or simply thickened rim.

3885x: The vessel is most likely coil built, in view of the 'oblique banding' that was observed especially on the external surface.

3.8.16 Coarseware shallow bowls and dishes, miscellaneous rim types

Used for individual servings or condiments? Note that at least two of these have graffiti or owner's marks.

3.8.17 Deep dishes with flanged rims; deep bowls with beaded or flanged rims

These are larger forms than 3.8.16; the more shallow may have been used as simple serving dishes.

2910x: The example from (HA2) is Meroitic?

3.8.18 and 3.8.19 Deep hemispherical coarseware basins with rim variations

The larger could have been used as mixing bowls, but like most of the coarseware forms they probably were put to a variety of uses.

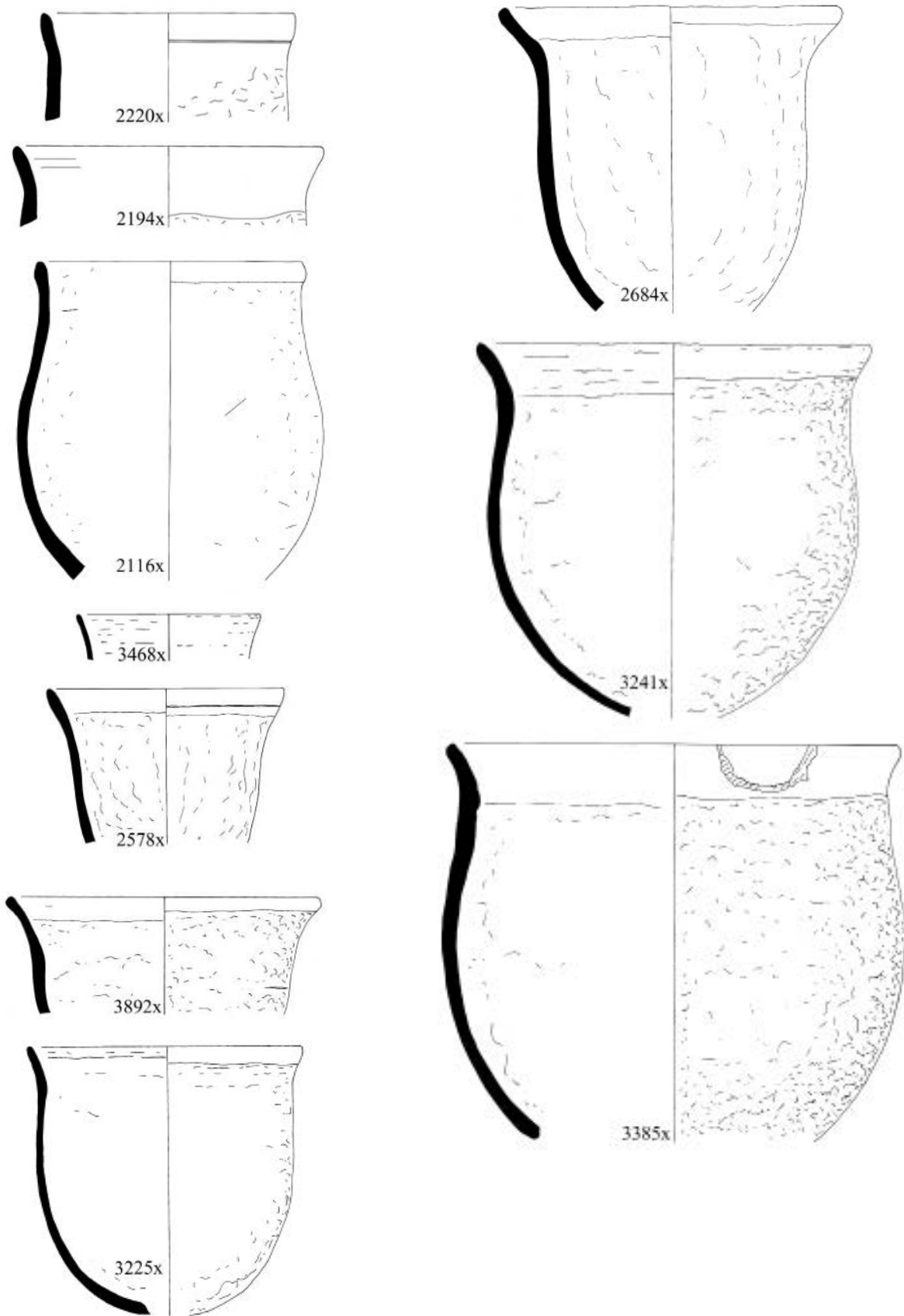

Figure 3.8.1. Deep coarseware bowls with 'S'-shaped profile (scale 1:4).

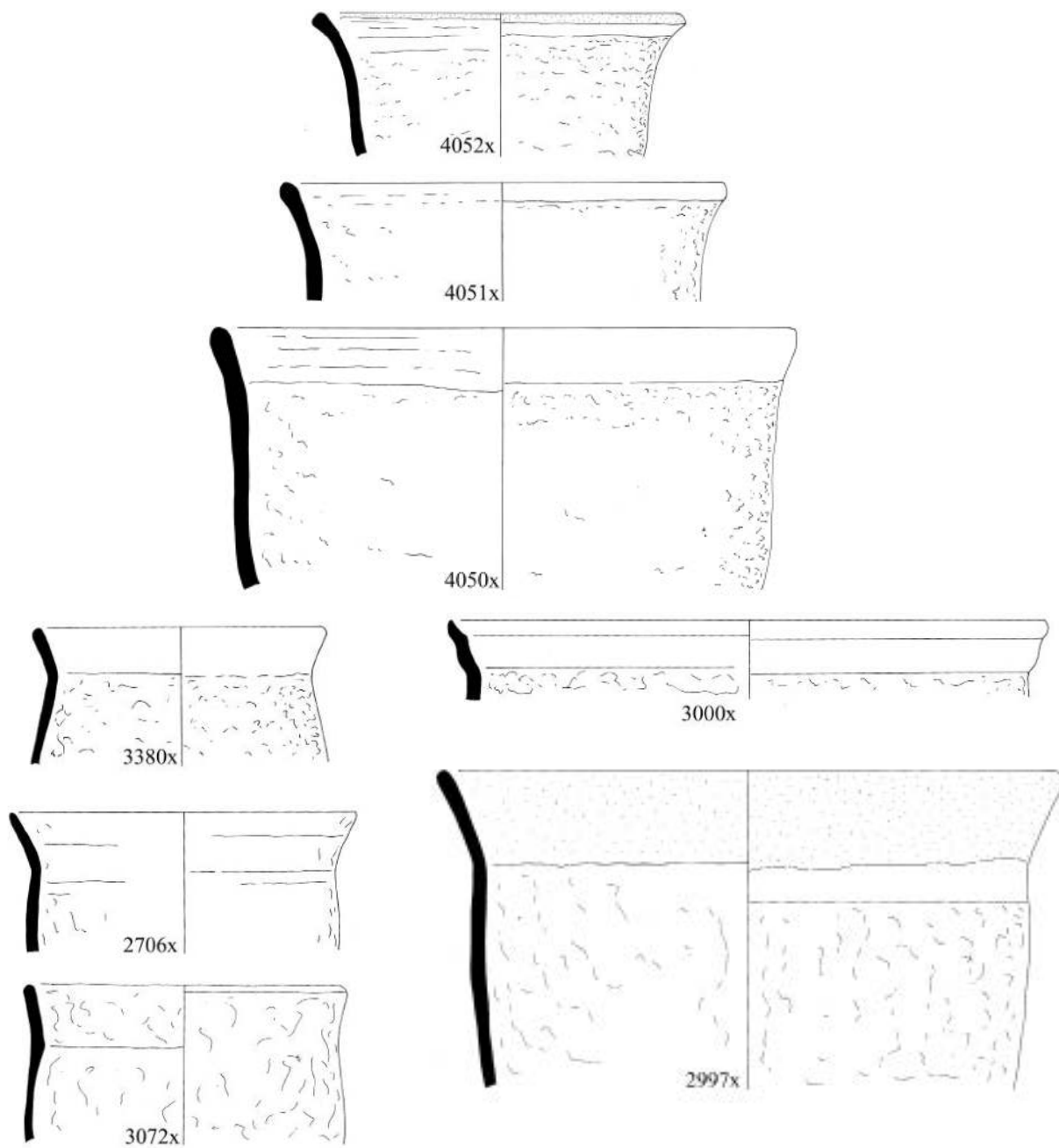

Figure 3.8.2. 'S'-shaped profiles, continued (scale 1:4).

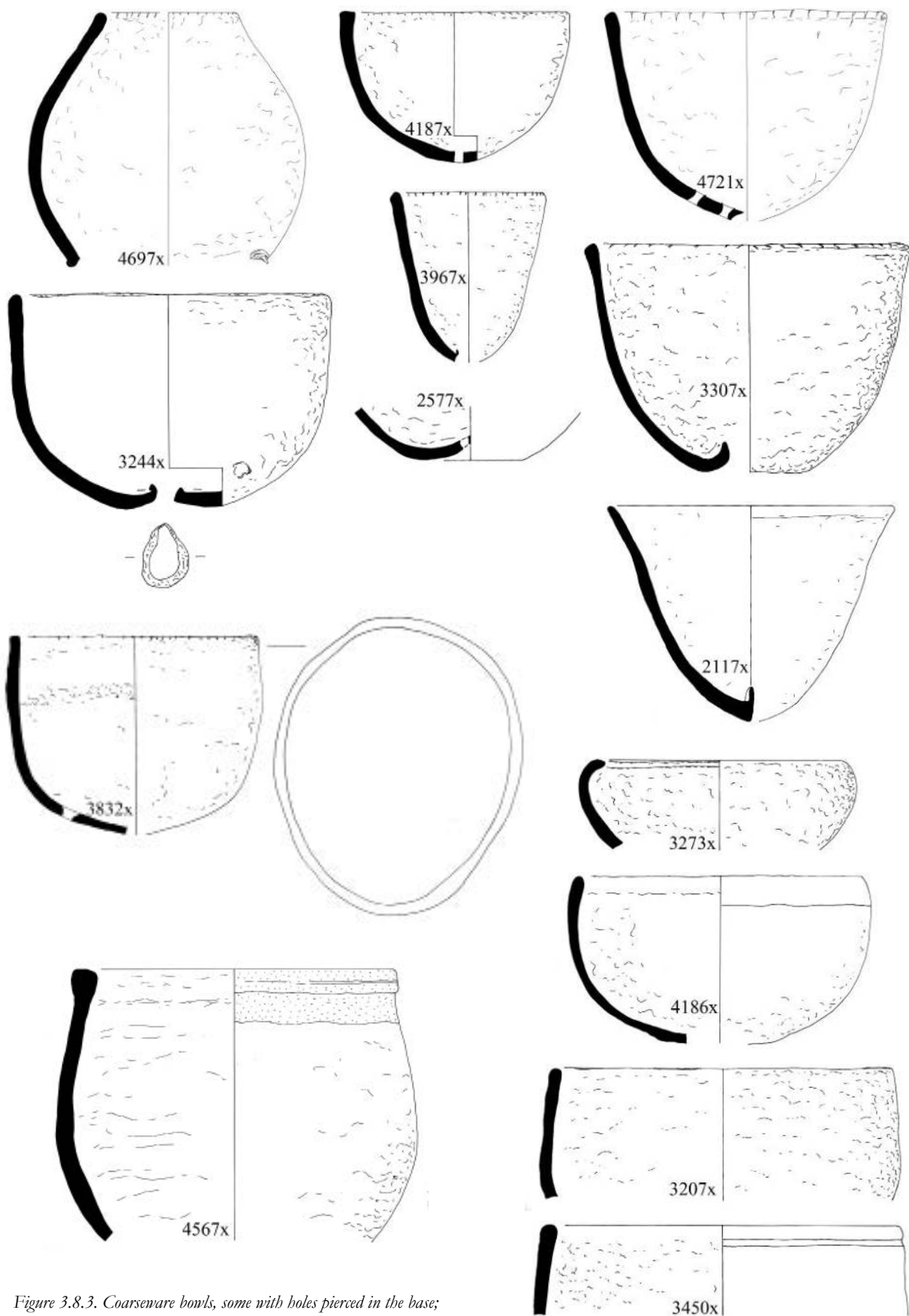

Figure 3.8.3. Coarsenware bowls, some with holes pierced in the base; miscellaneous forms with inverted sides (scale 1:4).

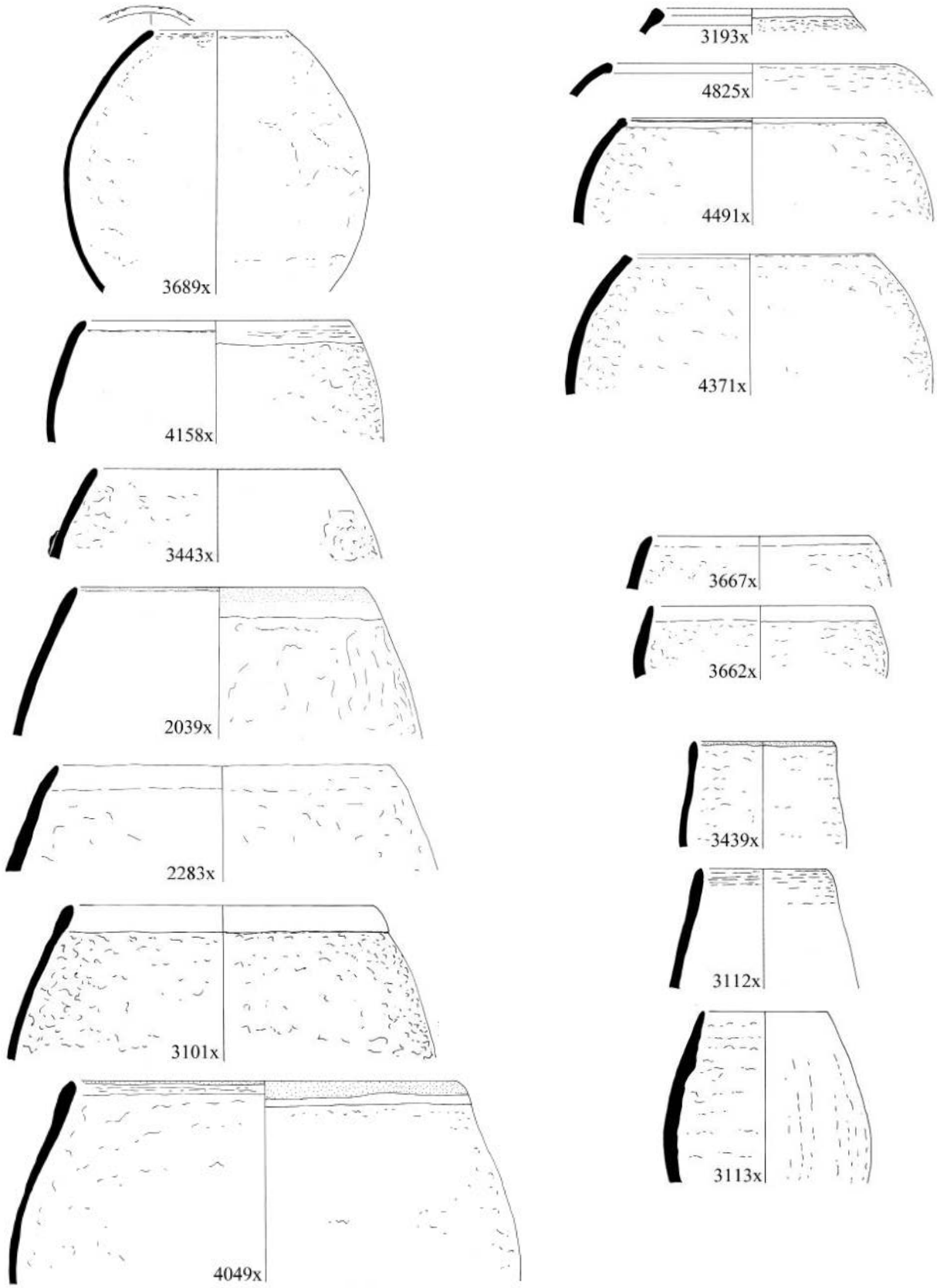

Figure 3.8.4. Coarseware bowls with inverted rims (scale 1:4).

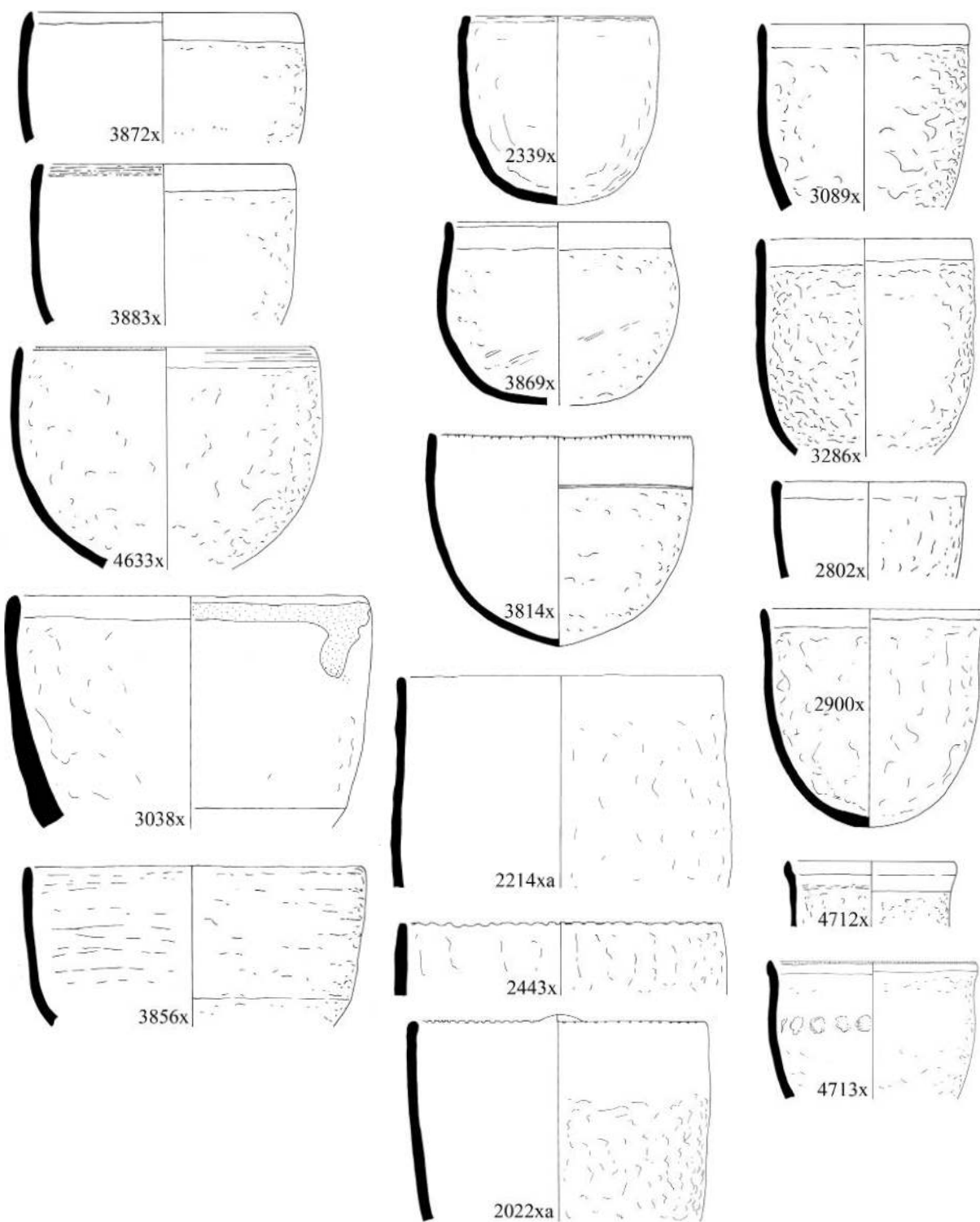

Figure 3.8.5. Coarsenware bowls or cooking pots with vertical sides and plain rims (scale 1:4).

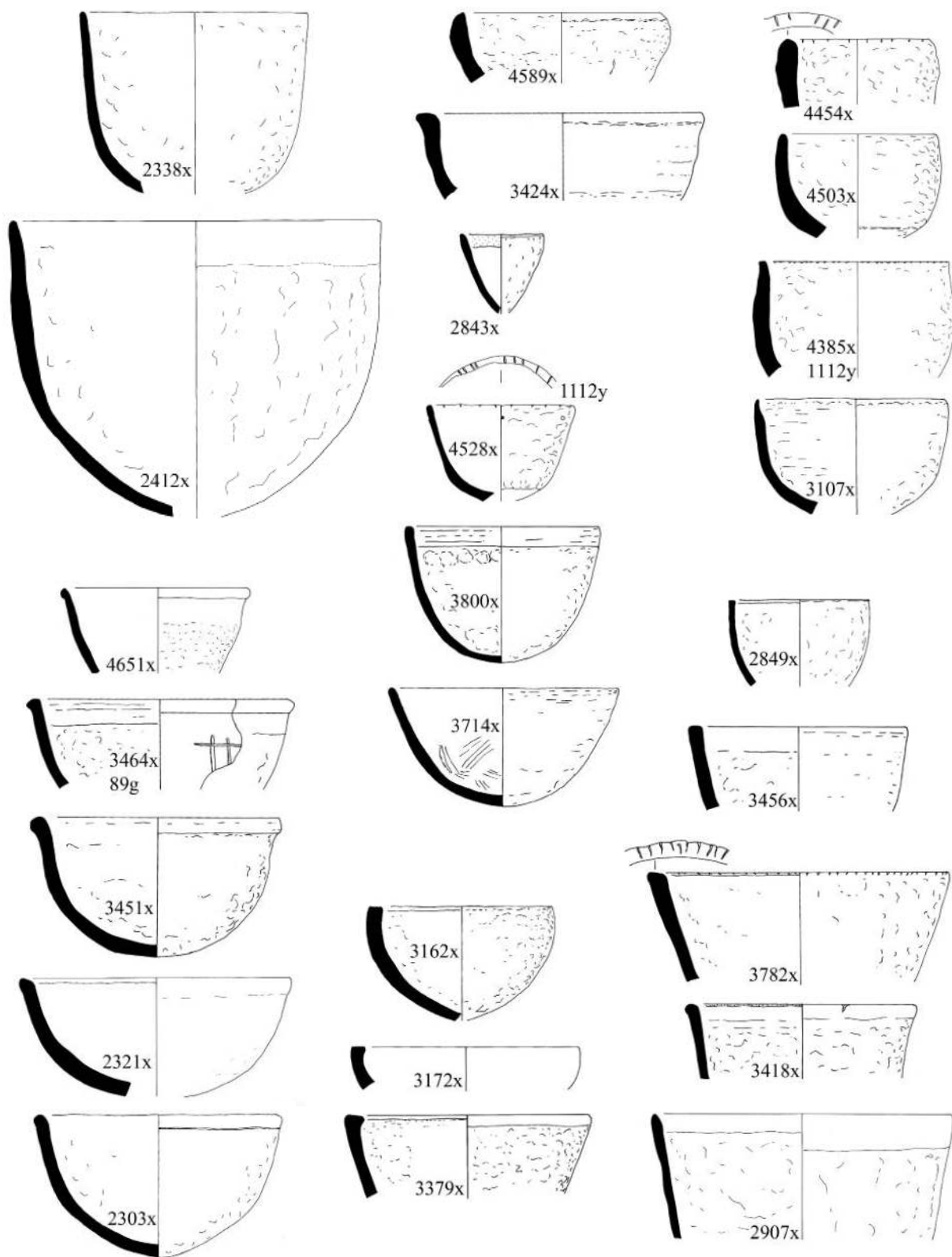

Figure 3.8.6. Deep, everted coarseware medium-sized bowls and small cups or bowls (scale 1:4).

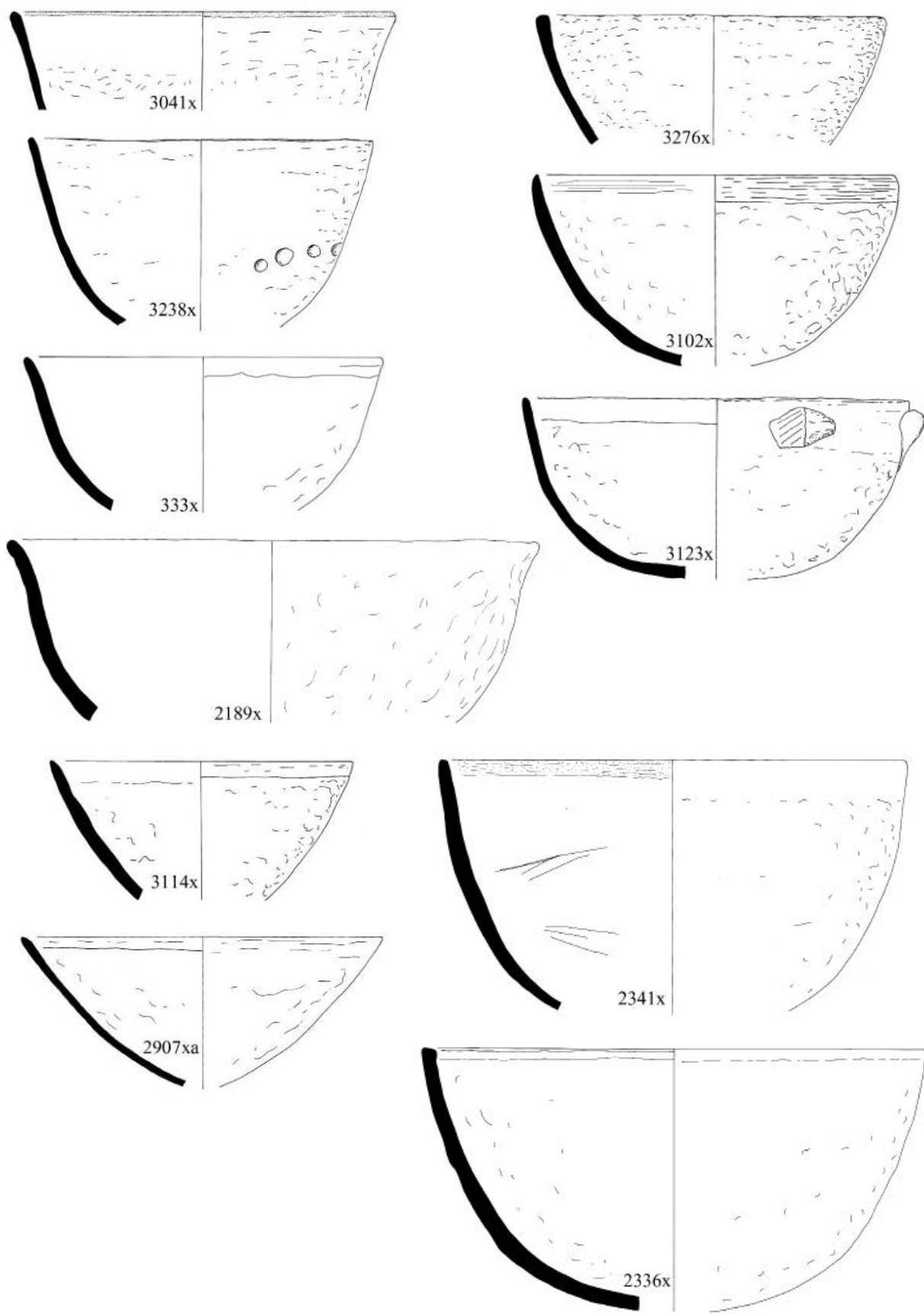

Figure 3.8.7. Open coarseware bowl forms (scale 1:4).

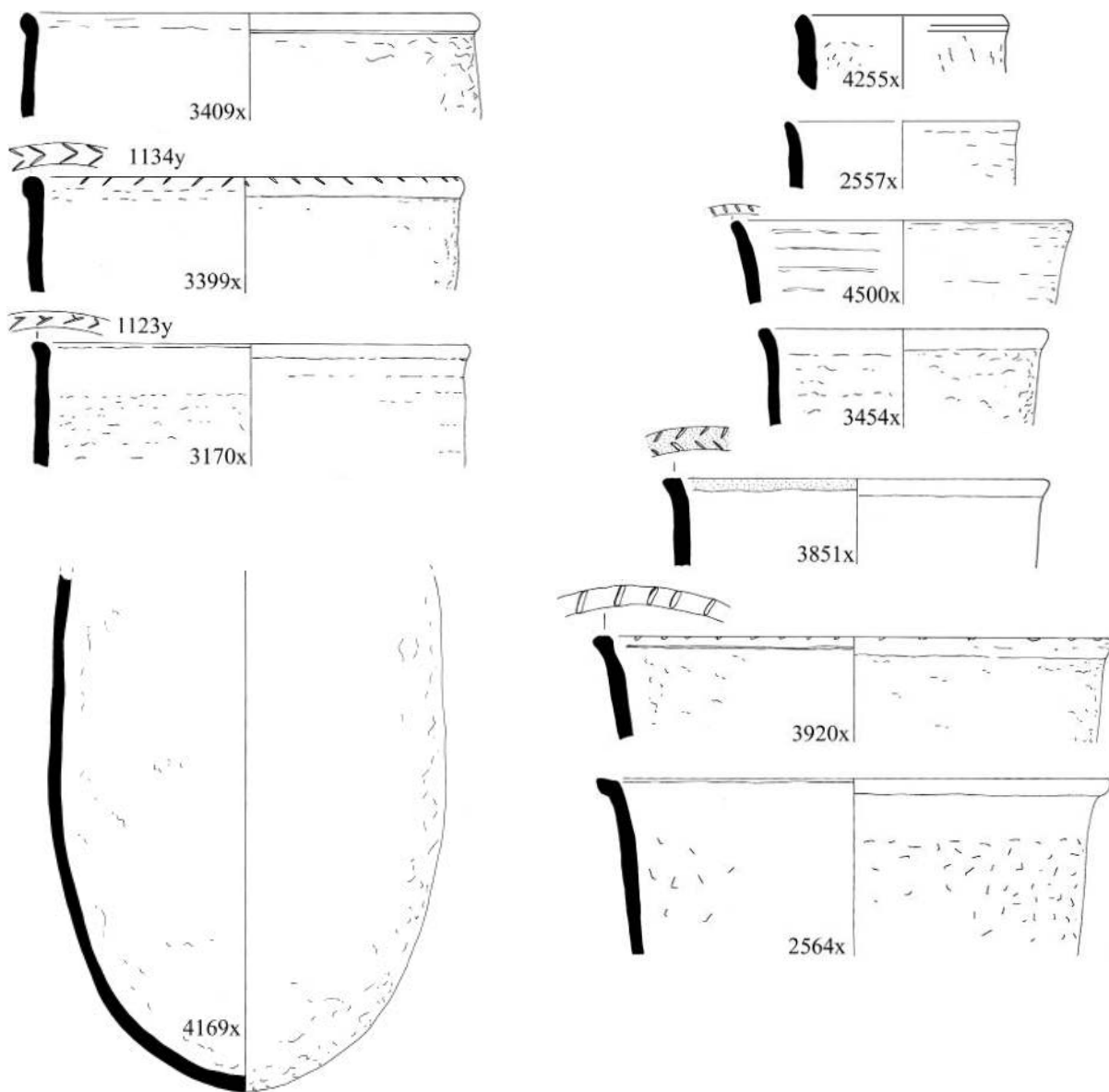

Figure 3.8.8. Coarseware bowls with beaded rims, everted plain rims and everted flanged rims, and a very deep, rimless body (scale 1:4).

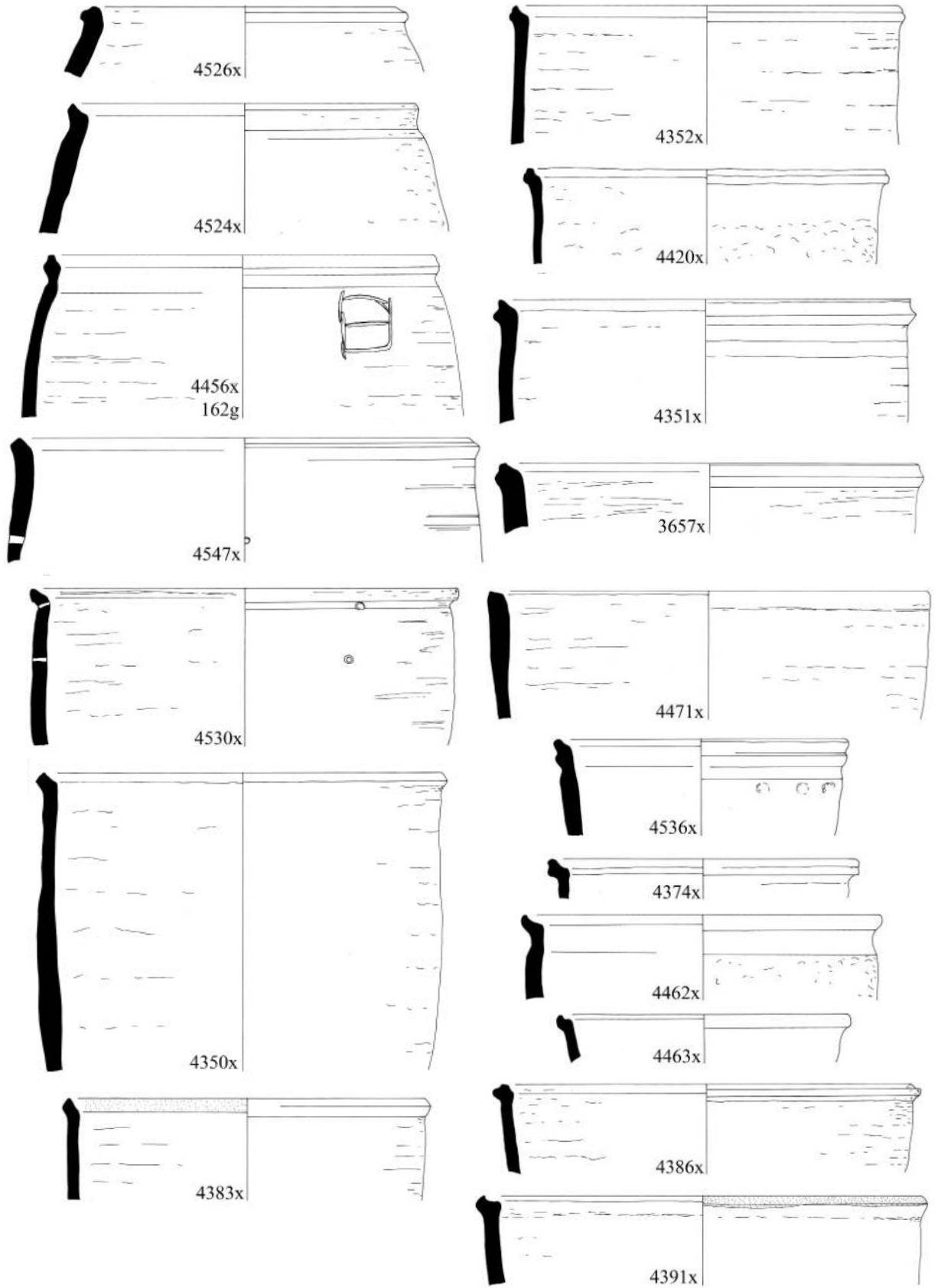

Figure 3.8.9. Deep coarseware cooking pots, with lid seating variations (scale 1:4).

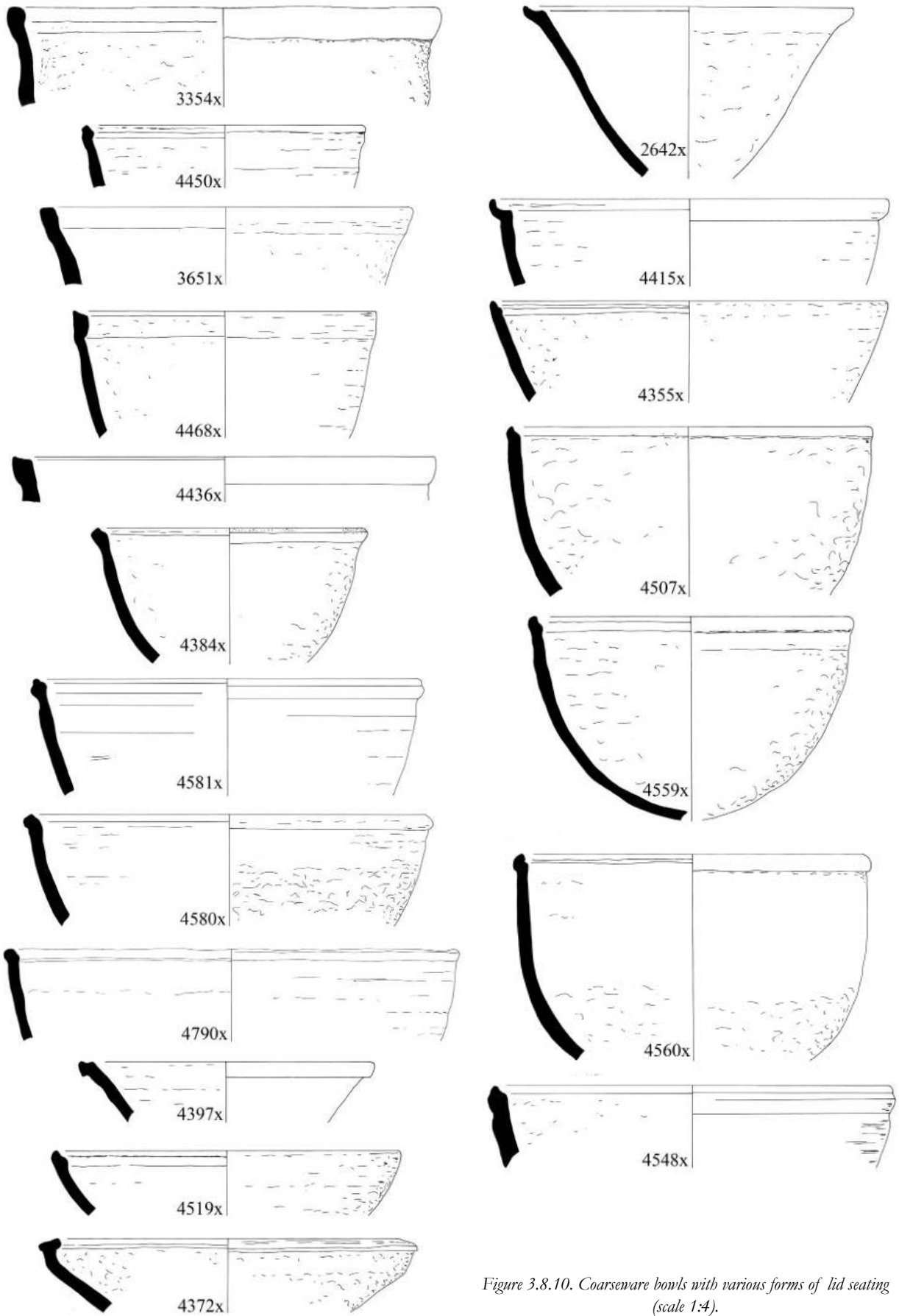

Figure 3.8.10. Coarseware bowls with various forms of lid seating (scale 1:4).

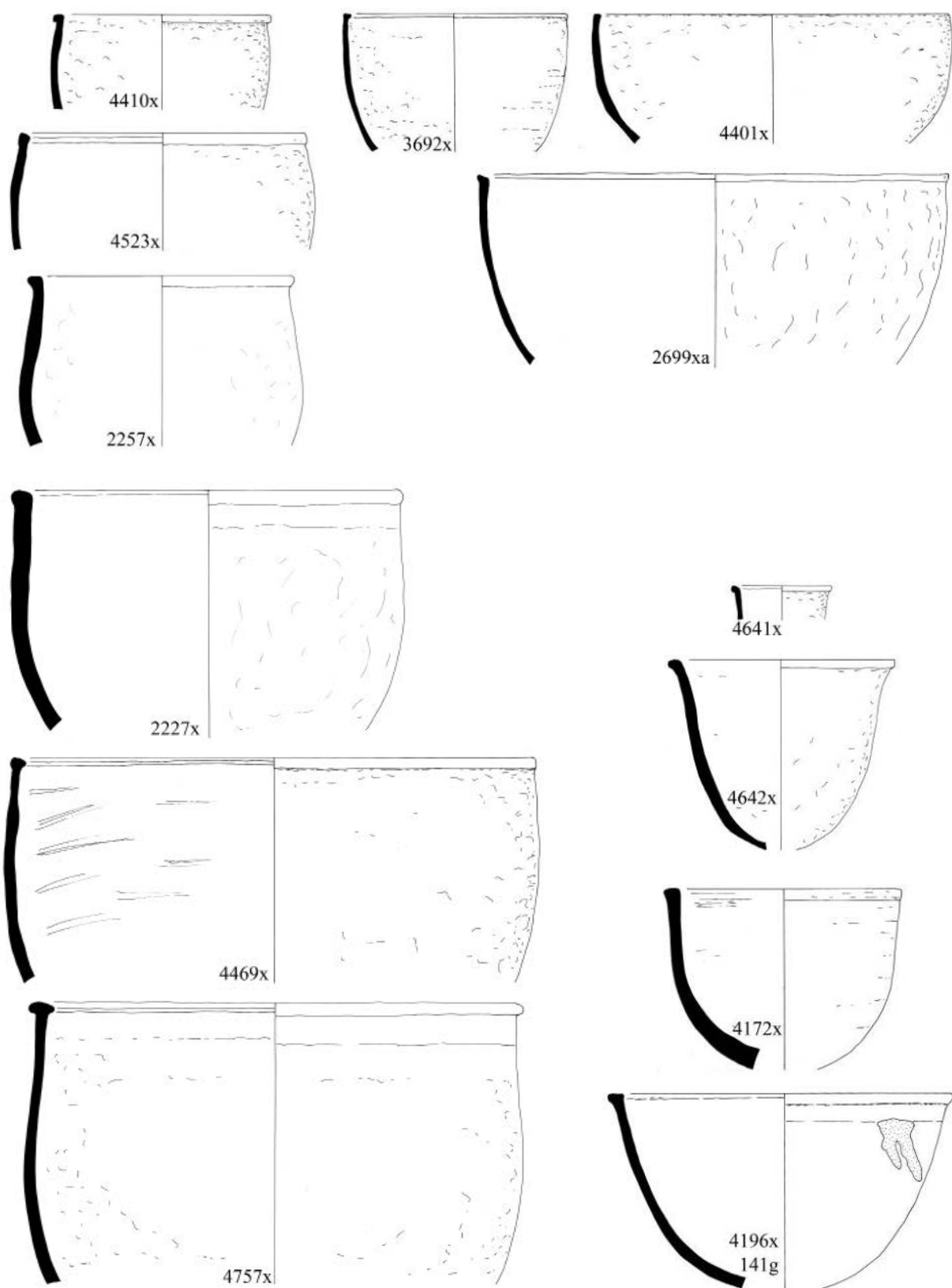

Figure 3.8.11. Deep coarseware bowls with flanged rims (scale 1:4).

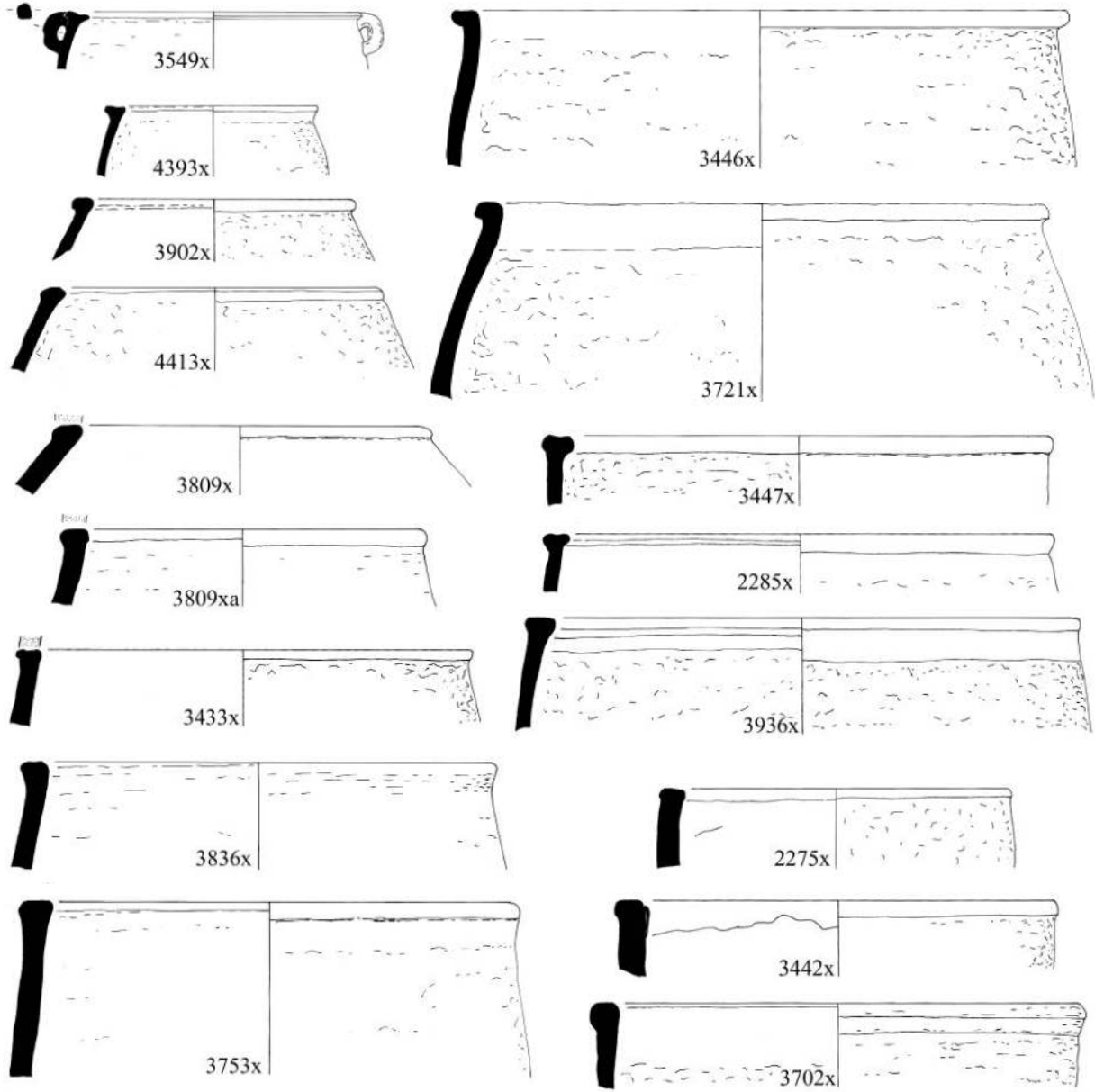

Figure 3.8.12. Coarseware closed jars with some form of beading or flattening of the rim top (scale 1:4).

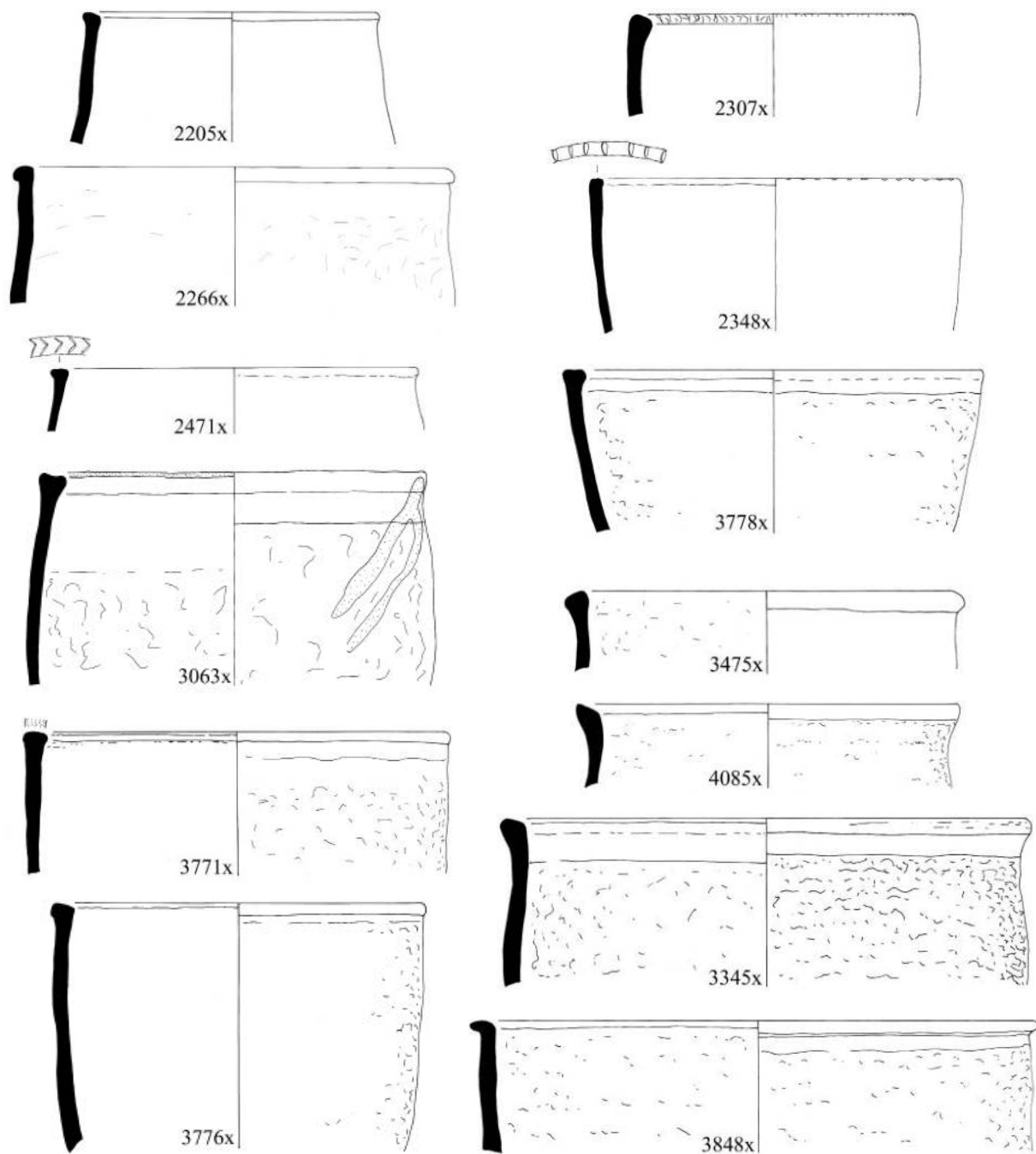

Figure 3.8.13. Deep coarseware bowls with vertical sides and internal or external beading (scale 1:4).

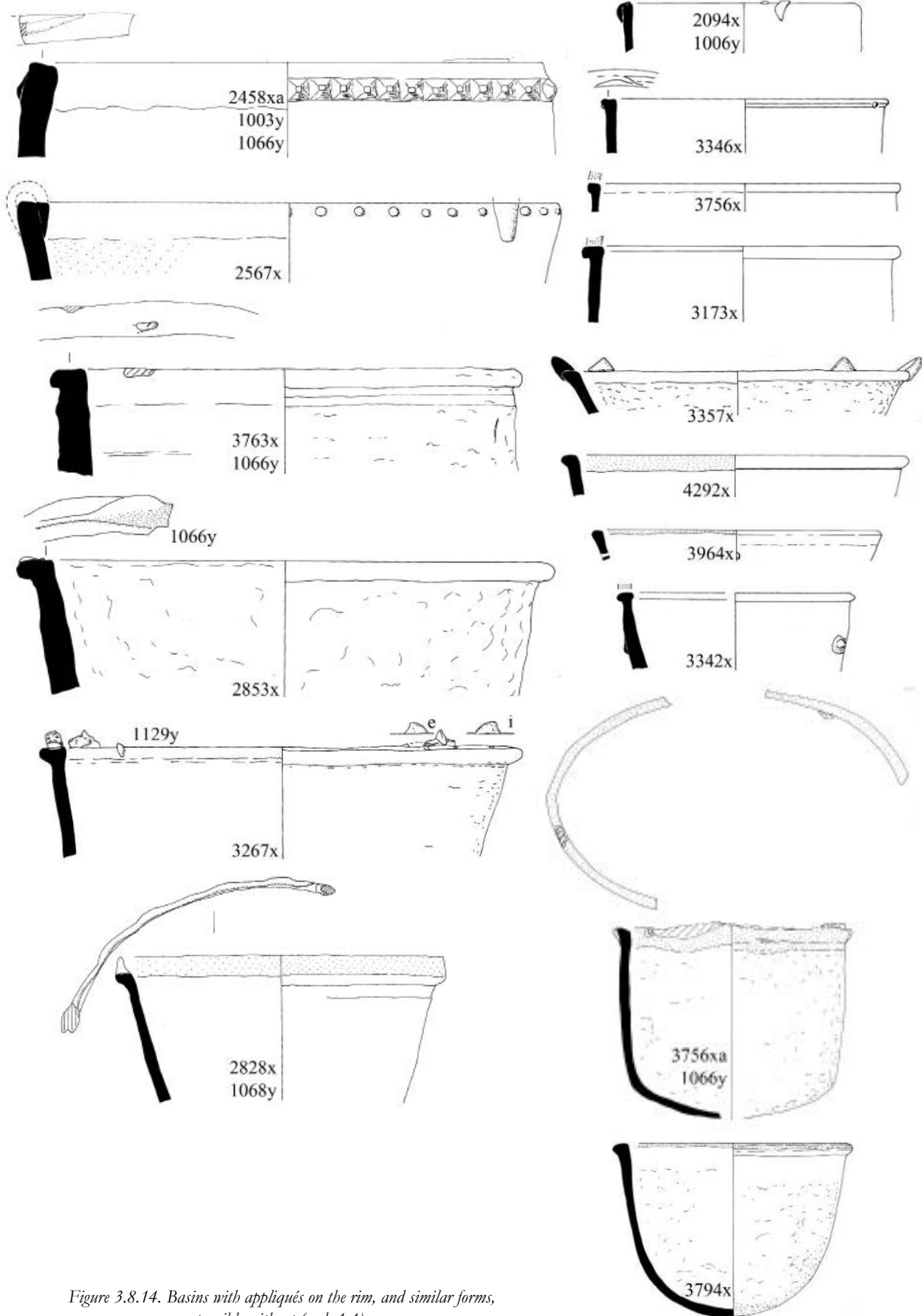

Figure 3.8.14. Basins with appliques on the rim, and similar forms, possibly without (scale 1:4).

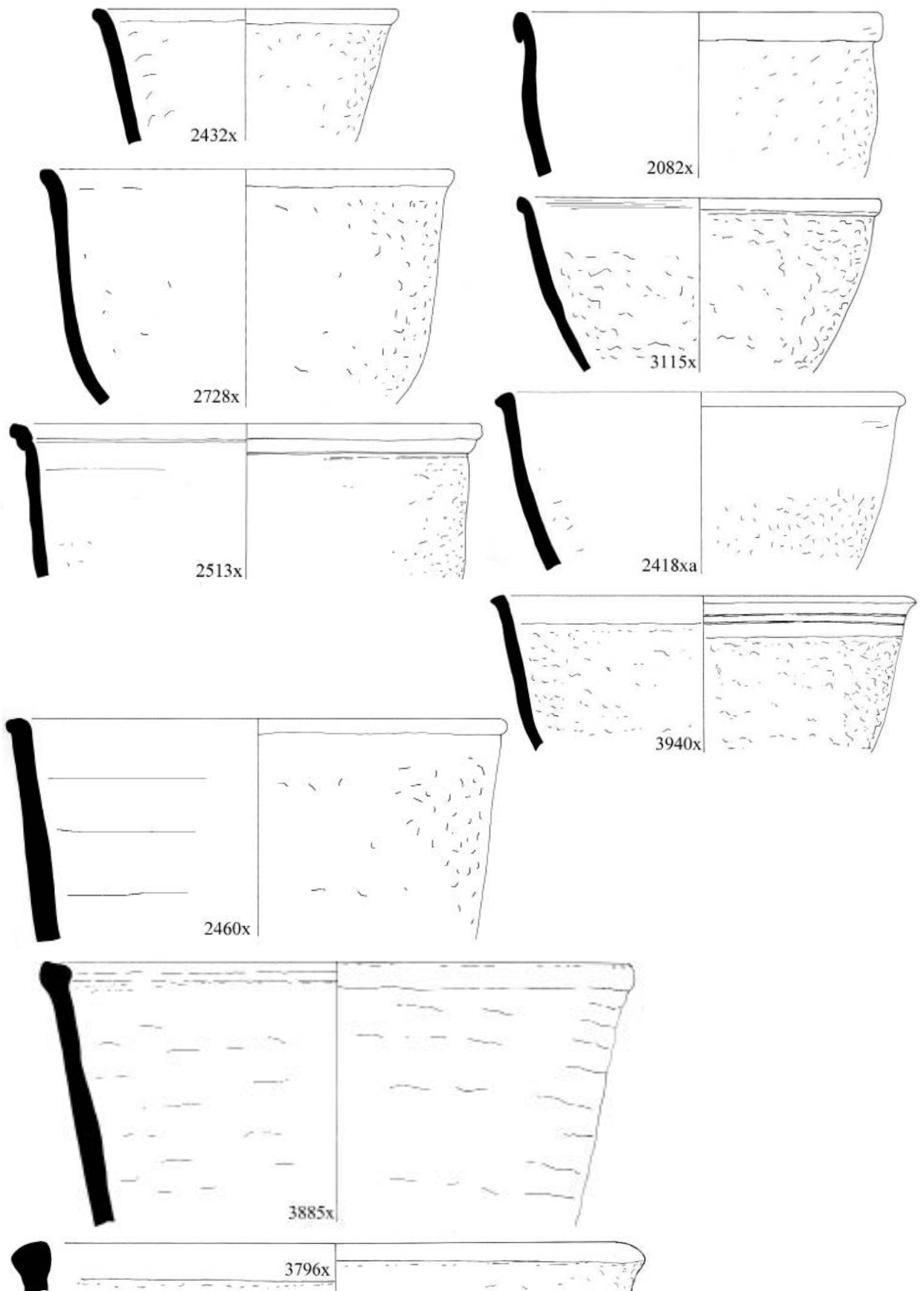

Figure 3.8.15. Deep coarseware bowls and basins (scale 1:4).

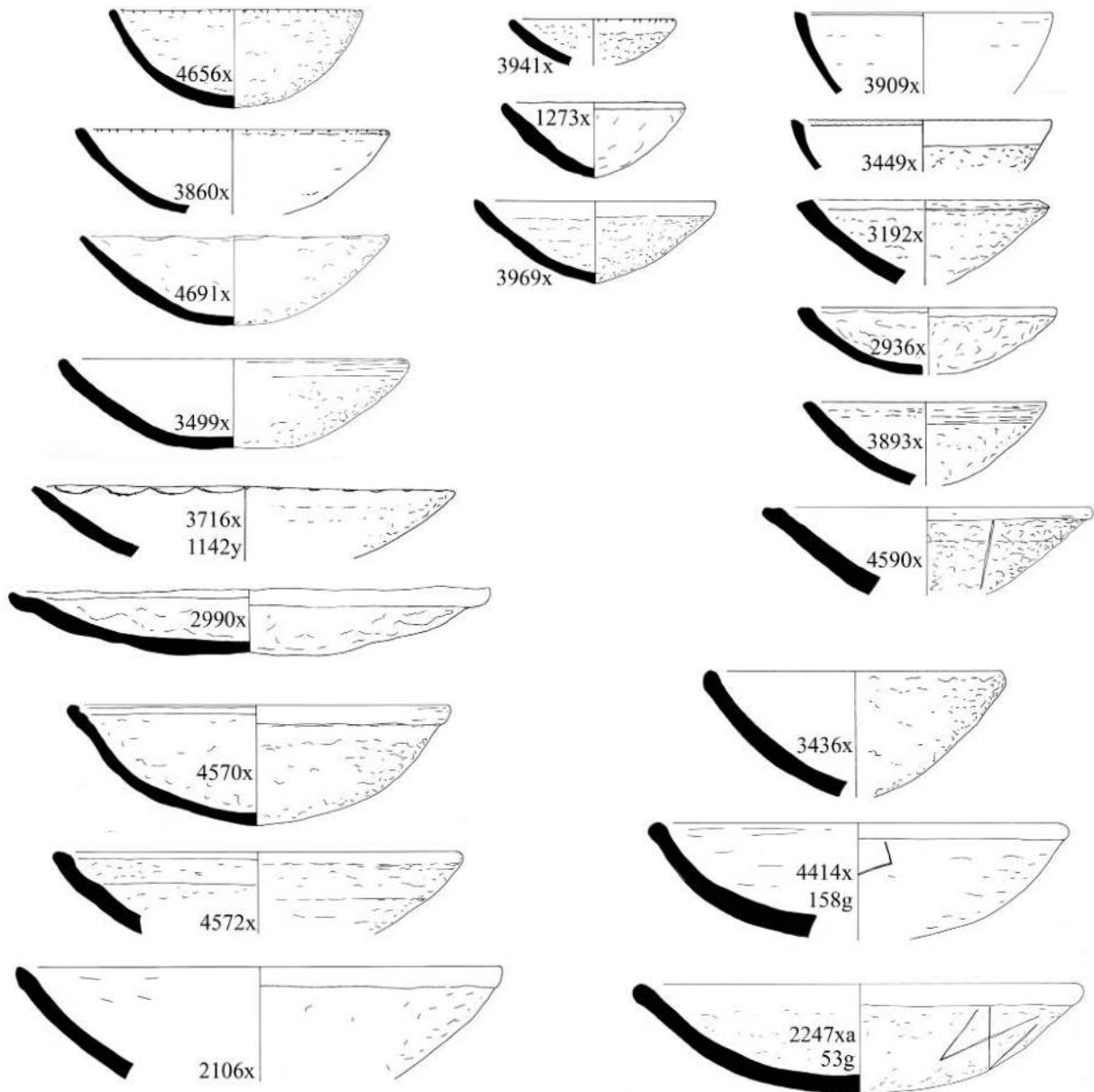

Figure 3.8.16. Shallow coarseware bowls and dishes (scale 1:4).

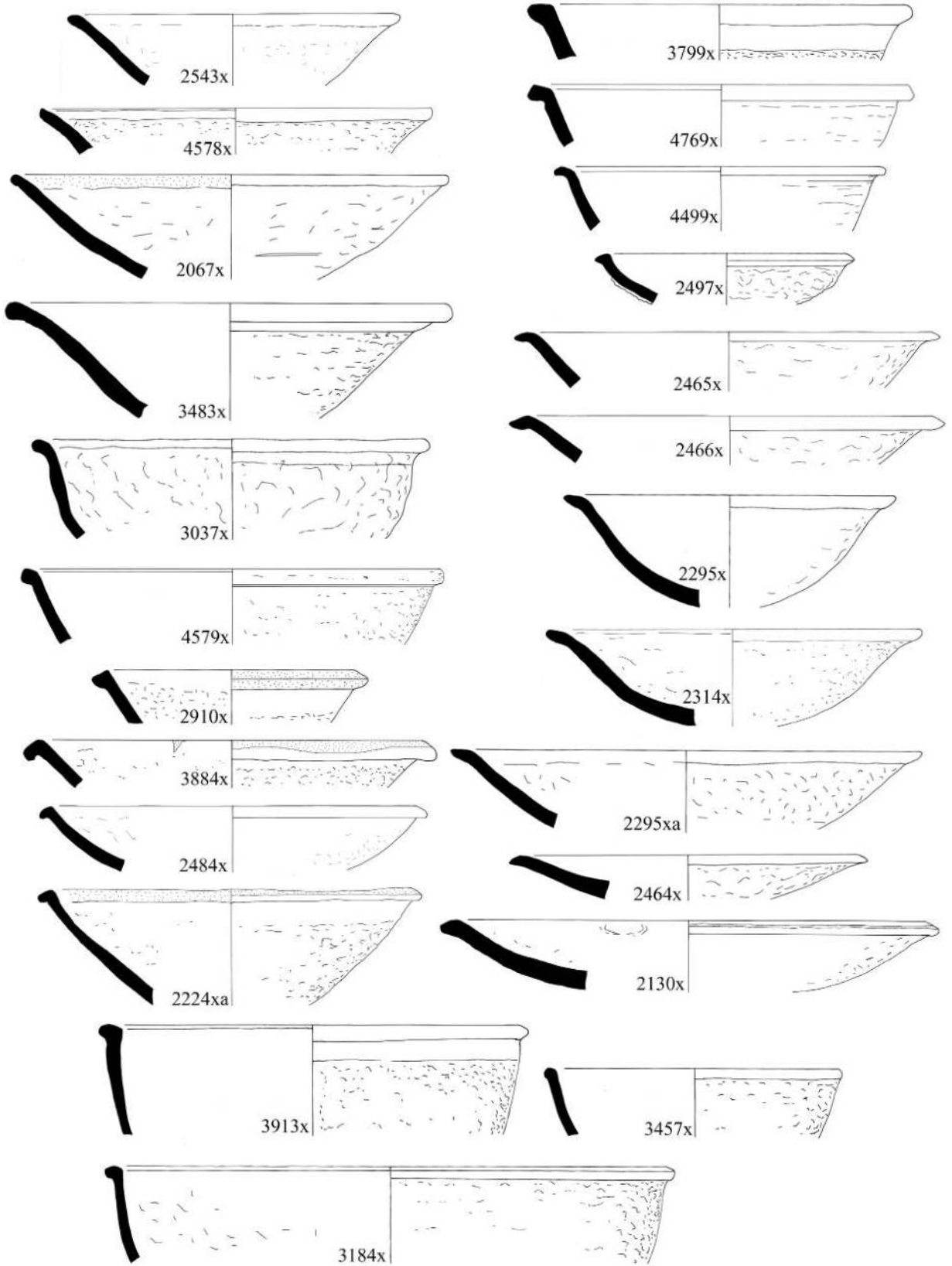

Figure 3.8.17. Deep dishes with flanged rims; deep bowls with beaded or flanged rims (scale 1:4).

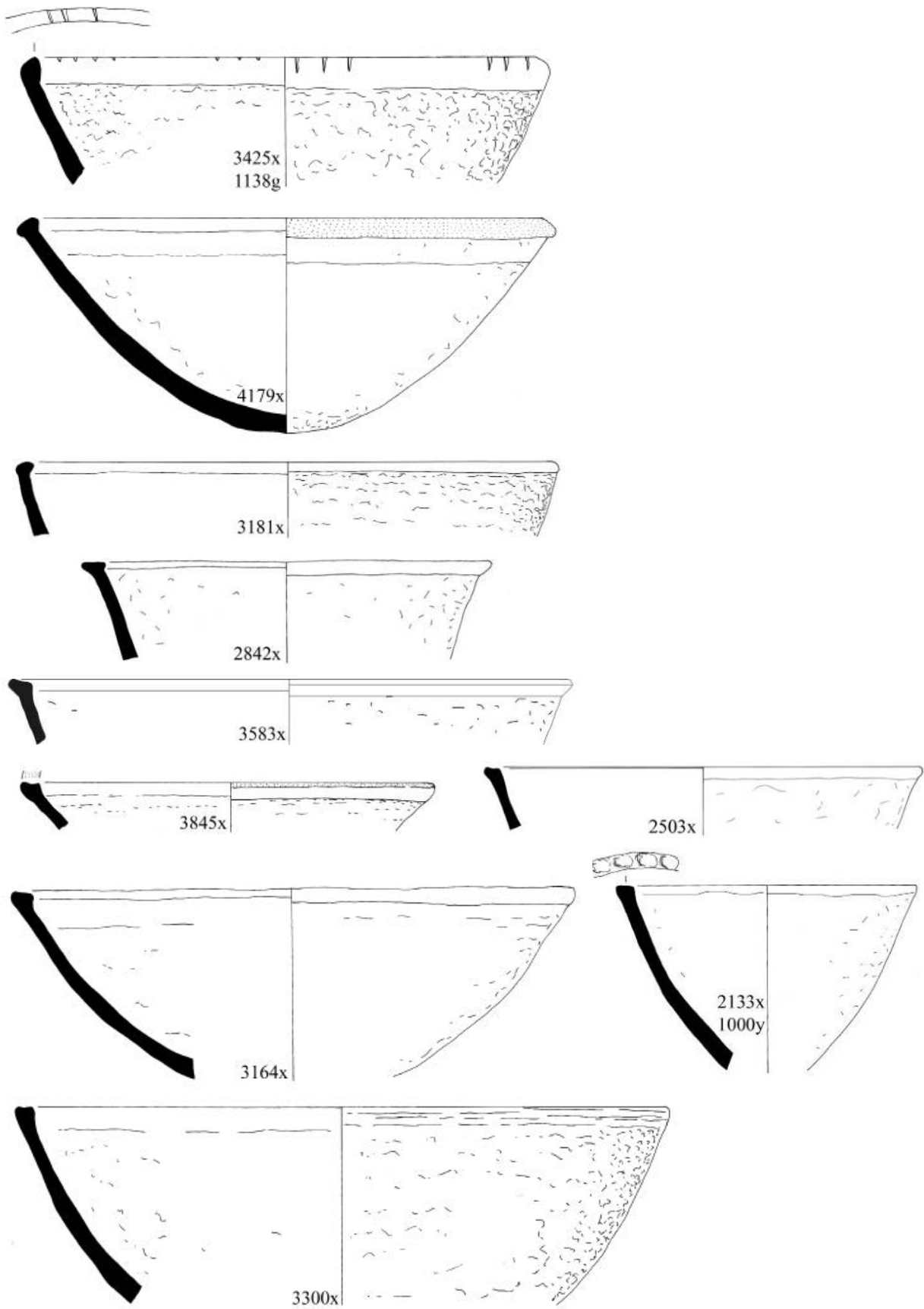

Figure 3.8.18. Deep, open coarseware basins (scale 1:4).

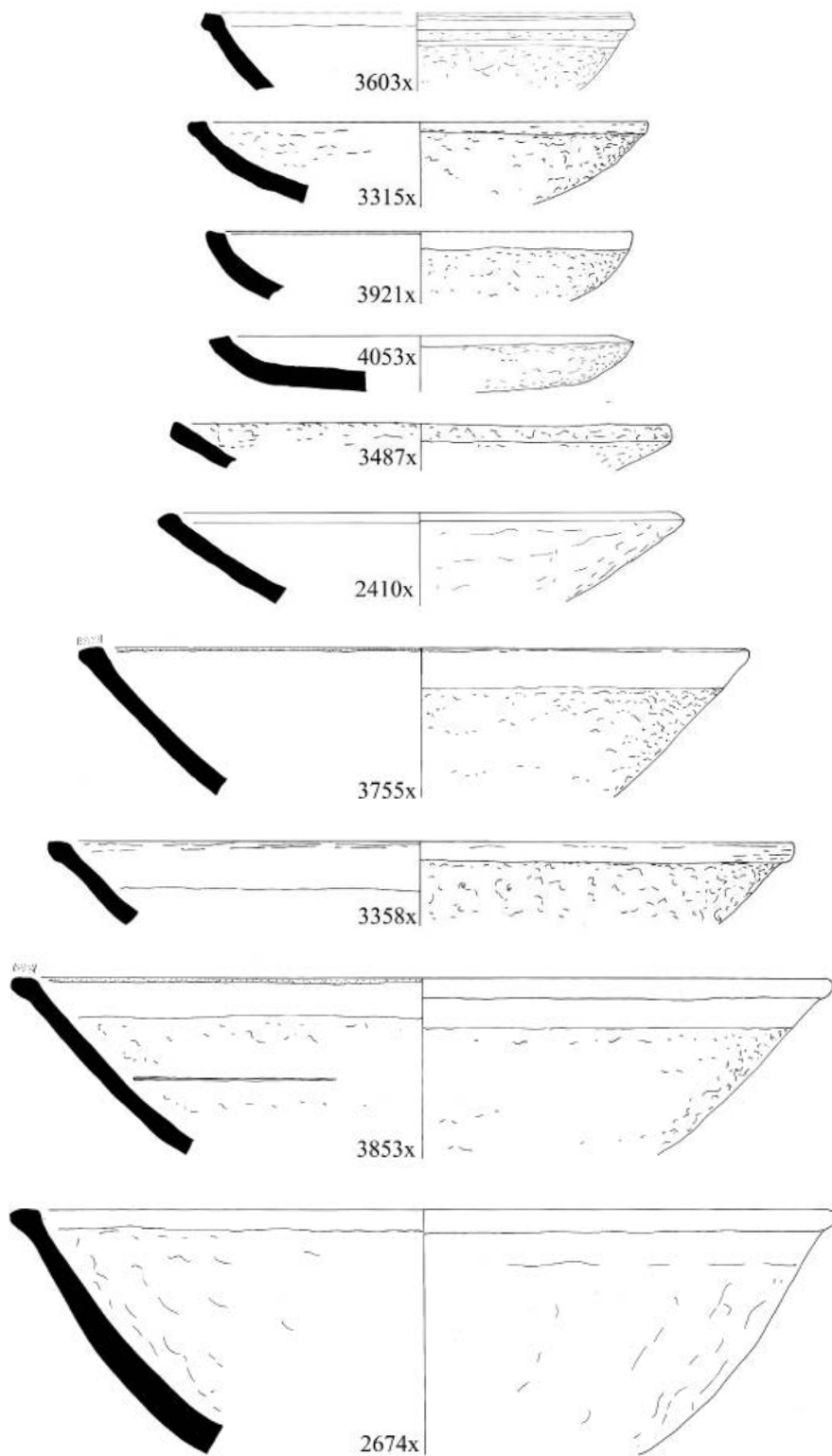

Figure 3.8.19. Deep coarseware basins, continued (scale 1:4).



3244x
3.8.3



3794x
3.8.14



Plate 3.8.1. Examples of ware 910 (3225x), CRR (3244x & 4656x); vessels with oval rims and appliqué scars; a coarseware dish.

TABLE 3.8. WARE 910.

Fig. no.	Type	Provenance	Fabric	Dec.	Surface treatment	Dia.	%	Man.	Comments
3.8.1	2116	(AB5)354 (AC6)22 (AD5)311 (BD2)65 (BE2)1 (BE3)63 (BF1)11 (FP7)10 (AB4)23,32 (AB5)5,20,29,66,211 (AD5)1,117 (BE1)26 (BE2)48,71 (BE3)16B (BE4)15,19 (BF1)56 (BF3)8,15,50 (CE4)48 (CE5)1 (FP7)23 (FR3)2 (FS3)1 (TG5)94	11 67 92 94 1 25 65 67 69 92 93 94	1067 850 x 2 871 x 1 20mm	820ER 910 RBR TOP 822R 825EW 910 RBRIE	13-29 13-34 13-30	56 289 48	HM HM WM HM WM	
3.8.1	2194	(AB5)1 (AC5)13 (AC6)1 (AD5)1 (BD2)49 (BE4)16	65 67 92		822R	13-30		HM WM	
3.8.1	2578	(AB4)4,10,11,14,23,31 (AB5)20,28,59,64,66,67,68,89,211 (AC5)0,13,17,18,23,34,36,37,46,49,68,102 (AC6)17,20 (AD5)1,7,12,34,54,59,87,113,115,116,117,123,133,134,135,141,160,164,168 (BD2)100 (BD3)8,28 (BD4)19 (BE2)158 (BF1)6,75 (CE4)71 (CF3)1 (CF4)1 (FO6)71 (FP6)172 (FP7)18 (FQ3)40,42,44 (FQ4)7,8 (FR3)0 (FR4)2 (JF2)1 (TG5)4,73,77,79	11 25 67 69 89 92 94 94C 95 105 110	5	820ER 820IR 825EIO 910 RBRIE	10-36	1399	HM WM	(FQ3)40 from brick I deformed
3.8.1	2684	(AB4)10,11,20,22,23,28,31,33 (AB5)25,32 (AC5)12,13,17,18,23,28,33,34,37,38 (AD5)1,7,25,28,34,47,49,56,67,117,126,132,134 (FO7)85 (FQ3)40 (FQ4)6,7 (FR4)1 (TG5)73,91	1 11 65 67 69 89 92 94 110		910	11-37	1339	HM WM SW	
3.8.1	+3225	(AC5)28,46 (AD5)34,56,67,77 136 (FP7)82 (FR3)13 (FR4)3 (JE3)43 gr. 132 (TG5)73	69 89 92 94 110		810 910	15-26	298	HM WM	
3.8.1	3241	533 7 (AC6)86 (AD5)20,28,60,66,87,99,102,123,127,141,232 (FR4)1 (TG5)94	19 92 94 110		910	22-31	229	HM	pre-firing hole
3.8.1	3385	(AD5)90	-		910	32	95	HM	reused
3.8.1	3468	(CE4)1 (GD3)139 GR 138 (FP6)118,171 (FR3)0	92 110		H805EI 822R 910	12-21	44	HM WM	
3.8.1	3892	(FO6)109 (FP6)21 (FR4)2 (TG5)73,91	110		910 RBRIE	12-40	120	HM	I deformed
3.8.2	2706	(AB6)10 (AC6)12,71 (AD5)217 (FS3)2 (FT3)2 (TG5)117	9 67 92 110		910 RBRIE	13-24	108	HM WM	
3.8.2	2997	(AC5)13 (AD5)7,56	69 94		825EIR 910	24-39	35	HM	
3.8.2	3000	(AB5)229 (AD6)19	67 110		910	38	10	HM	
3.8.2	3072	(AD5)1,87,157 (FP6)172	92 94		910	14-20	44	HM	
3.8.2	3380	(AD5)112,272 (FP6)154 (FR4)1 (FZ1)25	94 110		910 RBRI	9-20	77	HM	
3.8.2	4050	(TG5)4,73	92 110		910	28-37	25	HM WM SW	
3.8.2	4051	(CF4)1 (FP6)9 (TG5)73	110		910	18-28	33	HM	
3.8.2	4052	(TG5)1,44,73	110		910	23-24	45	HM	
3.8.3	2117	(AD5)1 (BE4)16 (BF1)57	1 94	5	910	25-27	32 + 200 B	HM	hole in base
3.8.3	2577	(AB4)10 (AB5)25 (BD2)28 (FS3)2	12 92 94		CRR	-	255	HM WM	pre-firing hole in base

Fig. no.	Type	Provenance	Fabric	Dec.	Surface treatment	Dia.	%	Man.	Comments
3.8.3	3207	(AC5)61,89,102,105 (AD5)41,167,168,183,214,239 (AD6)16 (CF4)17,81 (FO7)94 (FP6)34,57,96,105,138,143,179 (FP7)12 (FR3)0 (FS3)3,6,13 (TG5)65,89,138	110	200	CRR	16-26	365	HM WM	
3.8.3	+3244	(AC5)37 (AD5)28,154 (FP6)89,92,94,133,143 (FP7)31 (TG5)29	71 89 92 94 110		910 CRR	15-25	309	HM	central pre-firing hole in base
3.8.3	3273	(AC5)37,38	89			18	34	HM	898
3.8.3	3307	(AD5)(FP6)89,92,109 (FP7)19 (FQ3)58 (FQ4)23	69 92 110		820ICR CRR	20-24	146	HM	central pre-firing hole
3.8.3	3450	(AC5)79 (FR3)12 (CF4)1 (TG5)94	92 110		820IR 825ER 910 RBRIE	23-26	92	HM WM	
3.8.3	3832	(AC5)131 (CF4)113 (FO7)2 (FP6)90 (TG5)57,74	110		910 CRR	14-26	155	HM	post-firing base hole
3.8.3	3967	(CF4)133 (FP6)89 (FQ3)59	110		CRR	11-14	32	HM	pre-firing hole in base
3.8.3	4186	(FP6)34	110			21	17	HM	
3.8.3	4187	(FP6)34	110		CRR	17	45	HM	off-centre pre-firing hole
3.8.3	4567	(CF4)161	94		820IR	24	9	HM	
3.8.3	4697	(FP6)131	110		CRR	11	18	HM	hole 18mm fish spine impression near base
3.8.3	4721	(FP6)143	110		CRR	20	27	HM	2 holes 14 mm, off-centre
3.8.4	2039	(AB4)10,11,23,28,31,33 (AB5)35,89,211,287 (AB6)8,10 (AC5)18,28,34,37,38,46,49,51,53,126 (AC6)16,34 (AD5)20,28,49,67,84,87,93,107,117,128,134,136,149,157,160,161,161A,166,167,168,175,183,217,225,230,293 (AD6)13,16 (BC4)1 (BD2)28,45,49,50,59,61,63,71,89,99,100,101 (BD3)1,8,28 (BD4)16 (BE1)1,7,18,61,63,73,80 (BE2)1,10,18,21,51,56,57,70,71,88,103,116 (BE3)10,21,55,56,65,67,104,116,136 (BE4)11,14,15,16,19,60 (BF1)45,61,75 (BF2)31 (BF3)8,38,52,56 (CE4)2,4,11,14,20,23,29,37,47,48,58,65,71,85,86 (CE5)1,2,4,6 (CF3)1,5,8,11,13,14,22,24,26,30,31,49 (CF4)7,10,13,17,18,20,26,27,49,50,51,56,59,62,65,74,81,88,101,103,104,107,111,132,133,139,145 (CF5)1,2,4 (FO6)90,109,150,167,175,185,192 (FO7)1,2,11,20,30,39,44,68,69,73,76,85,86,89,90,94,101,123 (FP6)1,9,24,31,34,37,40,50,54,56,57,60,70,72,74,89,92,109,111,125,128,144,151,156,161 (FP7)2,11,12,17,19,21,23,28,30,31,34,52,53,55,59,63,72,74,81,93,99,112,123,149,151,179/188 (FP8)1 (FQ3)58,63,65 (FQ4)1,2,21,26,41,61,70,78 (FR3)2,4,12,15,22,27 (FR4)7,9 (FS3)4,6,9,11 (FZ1)2,8,10,11,24,25 (FZ2)1,17,22 (HA2)68 gr. 204 (JD2)18 - (JD3)1 (JE2)15 gr. 14 (JF1)2,24 gr. 23 (JG1)13 gr. 12 (JG2)1,202 gr. 175 (TG5)6,65,74,87,91,130 (ZH5)15	2 9 12 25 50 56 65 66 67 69 80 89 92 92C 94 94C 105 110	5 8 200 1017 1112 1204 850 x 1	825EIB 825ECR 825EICR 825ER 910 RBRE RBRIE NR- BRIE	11-36	8661	HM SW WM	often sooty Area C with 1017y

Fig. no.	Type	Provenance	Fabric	Dec.	Surface treatment	Dia.	%	Man.	Comments
3.8.4	2283	(AB4)1,7,11,23,33 (AB5)89,207 (AC5)13,28,167 (AC6)71 (AD5)0,25 (BD2)68,71,81,82 (BD3)28 (BE1)18,41,63,73 (BE2)73,158 (BE3)55,56 (BE4)9 (CE4)2,42,86 (CF3)26,29,41 (CF4)10,17,109,132 (FO6)92 (FO7)68 (FP6)9,161 (FO3)48 (FR3)19 (FR4)3 (TG5)52,65,87,96,130	1 2 65 67 69 80 89 92 94 110	5 1017	825EO 825ER 825EIW 910 RBRIE RBRE RBR	12-31	540	HM WM	I deformed (FO3) from brick
3.8.4	3101	(AC5)73,114,116,117,126 (AD5)249,312 (CE4)4 (CF4)1,57 (FO6)62,71,109 (FO3)47 (FO4)24,35 (JG1)13 (TG5)79,85 (ZH5)15,37	92 93 110	1017 851?	910 RBRIE	13-30	517	HM	
3.8.4	3112	(AC5)68,70,125,128 (AD5)248 (BF1)61 (CE4)4,6,7 (FO6)11 (FO7)44 (FP6)125,128,149,151,154 (FP7)1,23,32,64,74,95,102,137,141,142 (FO3)10,11,65 (FO4)3,7,21 (FR4)1 (FS3)9 (FZ2)1 (TG5)91 (ZH5)37	25 94 110	200 1017	910 RBRIE RBRI RBRE RBR	9-25	1033	HM	
3.8.4	3113	(CE4)48 (TG5)46 (ZH5)37	92 94 95		820ER 825ER	9-20	57	HM WM	
3.8.4	3193	(FT3)44	92		910	14	9	HM	
3.8.4	3439	(AC5)125,131,132 (AD6)19 (CE4)20,86 (CF4)20 (FO6)15,59 (FP6)0,8,20,31,137,151,155,159 (FP7)106 (FO3)8,42 (FO4)2,35 (FS3)11 (FZ1)8,10 (TG5)102-105	92 110	1017 1112	910 RBRIE	8-25	525	HM	
3.8.4	3443	(AD5)316 (CE4)37 (FP7)11 (FO4)77 (FS3)6 (GD3)139 gr. 138 (JD2)43 gr. 40 (TG5)12,122	92 110	8VAR 200 1017 1112	820EP 910 CRR	15-28	69	HM	
3.8.4	3662	(TG5)18	92		910	16	5	HM	
3.8.4	3667	(FP6)188 (FZ2)47,54 (JD2)51 gr. 40 (TG5)18	92 93 110		910	16-21	18	HM	
3.8.4	3689	(CE4)1 (CF3)1,8 (CF4)20,62 (CF5)1 (JH3)18 gr. 6	92 92C 110	1017	910	10.5-30	114	HM	
3.8.4	4049	(CF3)1 (FO7)68 (TG5)73	92 110		910 RBRR	23-28	194	HM	
3.8.4	4158	(FO6)71	92		910	19	15	HM	
3.8.4	4371	(CE4)2,4,11,20,37,42,48,58,71,85 (CE5)2,6 (CF3)2,5,11,22,29 (CF4)10,13,17,20,50,59,67,75,107,128,138,142 (CF5)5 (TG5)1	11 92 94 110	1017 1112	820IP 820IW	12-32	487	HM	sooty exterior
3.8.4	4491	(CE4)85 (CF4)101	110			15-19	25	HM	
3.8.4	4825	(JF2)84 GR 55	110		910	21	11	HM	
3.8.5	2022a	(AC5)145 (AD5)160 (CE4)2,9,11,20,29,47,85 (CE5)4,6 (CF3)13,22 (CF4)1,7,17,18,75,101,103,111,113,132 (FO6)121,167 (FP6)28,94 (FP7)2 (FO3)58 (FO4)37,119G (JD2)43 GR 40 (TG5)6,74	67 92 94 94F 105 110	110g 1017 1190 1204 1212 1219 1233 850	820IR 822P 822R 910 CRR WRBRIE	13-40	414	HM SW WM	
3.8.5	2214a	(AB4)7 (AB5)32 (AC5)13,37,107 (AC6)22 (AD5)1,167,193 (BC4)1 (BD2)28 (BD3)9 (BD4)17 (BE1)1,6,8 (BE2)48,71,109 (BE3)20,28,37,55,63,70,78,136 (BE4)9,12,19 (BF1)6,11,35,53 (BF3)26 (CE4)2,47 (CF4)17,65,73,74,75,96,159 (CF5)1 (FO6)60,62,63,66,116,145 (FP6)32,70 (FP7)116 (FO3)7 (FR3)1 (FT3)12 (TG5)119 (ZH5)36	1 2 9 11 65 67 69 80 81 92 94 94C 110	1017 850	822R 825IW 910 RBRR TOP RBRIE	13-35	859	HM WM	(CF5) deformed

Fig. no.	Type	Provenance	Fabric	Dec.	Surface treatment	Dia.	%	Man.	Comments
3.8.5	2339	(AB4)10,20,23 (AB5)59 (AB6)11 (AC5)13,18,72,73,77,78,82,93,105,107,112,114,116,117,124,125,126,127,128,129,132,134,144,145,150,162,164,172,174 (AC6)22,34,54,84 (AD5)20,34,87,99,168,184,207,214,217,219,241,246,249,256,258,269,272,273,276,278,281,283,288,289,296,298,311,315 (AD6)4,5,14,16,19 (BD2)100 (BD3)16 (BE1)44 (BE2)10,56,71 (BE3)10 (BF1)73 (BF2)56 (CE4)37 (CF4)13,17,113,138 (FN6)2 (FO6)3,4,46,48,61,66,71,92,93 (FP6)2,37,57,90,151 (FQ3)43,58 (FQ4)20,23,37,59,61,88,112 (FR4)7,9 (FS3)11 (JG2)178 gr. 175 (TG5)73,91 (AB5)89 (BD2)99 (BE2)71 (BE3)11,10,106	1 2 9 20 65 67 69 92 94 110	200 103 1 1112	820E 82.5EIBL 910 CRR RBR TOP	9-31	2642	HM	pre-firing base hole
3.8.5	2443	(AB4)23 (AB5)59 (AC5)45 (AD5)20,31,45,87,112,129,215,251,254 (BC2)4 (CF4)62,101 (FO6)121 (FQ4)3 (TG5)11,102	1 8 11 92 69 94 119	200 103 1 1112	910 CRR RBR	9-29	48	HM	
3.8.5	2802	(AC5)73,78,113 (AD5)22,48,56,67,186,227,251,256 (BC3)3 (CE4)2 (CF4)17 (FN6)2 (FO6)114 (FP6)1,21,24,36,38,128,171 (FQ3)7,42,58 (FR3)0,13 (FR4)2 (FS3)4,6 (JG2)1 (TG5)5/4,94	69 92 94 110	1142 931E	910 CRR NR- BR	12-25	705	HM	(FQ3)7 from brick
3.8.5	3038	(AC5)99 (CE4)42 (CE5)1 (CF4)17 (CF5)1 (FP6)111 (ZH5)30	92 94 110 117	1190 1212	820IR	15-30	70	HM WM	
3.8.5	3089	(AC5)73,77,116,126,128,170 (AD5)4,190,214,258,281,299,304 (CF3)49 (CF4)65,88,161 (FO6)1,2,19,37,54,62,99,154,157,172 (FP6)9,34,37,56,57,73,90,138,154,159,171,181 (FP7)21,28,45,82,153 (FQ3)7,42 (FQ4)23,44,55,68,75 (FR4)2 (FZ)1,2,12 (JF1)10 (TG5)7,85	69 92 110		910 CRR RBR TOP NRBR	11-27	948	HM	(FQ3)42 from brick I deformed
3.8.5	3286	(AC5)2,23,45 (AC6)71 (AD5)12,47,54,133,168,217,236,281,282 (CE4)1,14,40,71 (CE5)1 (CF4)1 (FO6)2,150 (FO7)20,68,150 (FP6)153,172 (FP7)1,2 (FQ3)63 (FS3)6 (JG2)1	67 69 89 92 94 110		910 RBR TOP RBR NR- BR	8-28	617	HM	
3.8.5	3814	(AC5)108 (CF4)3 1 (CF4)18 (FO6)125 (FO7)69,96 (FP6)5,54,89,118,128 (FP7)21,28 (FQ3)43 (FQ4)75,77,80 (JD2)51 GR 40 (JG2)254 GR 150	92 110	1151 931E	910 CRR	15-29	202	HM	
3.8.5	3856	(AC5)164 (AD5)256 (FO6)59,107,116,138,155 (FO7)20 (FP6)2,9,34,54 (FQ4)23 (TG5)94	92 110	137g	910 CRR RBR	16-27	303	HM	
3.8.5	3869	(AC5)164 (AD5)257 (CE4)1,86	92 110		910 RBR	15-28	75	HM	
3.8.5	3872	(AD5)311 (CF3)49 (CF4)31,109,128 (FO6)91 (FO7)2,3 (FP6)70 (FQ4)59 (TG5)4	110	1112	910 RBR TOP	10-28	186	HM	
3.8.5	3883	(AC5)173,322 (CE4)1 (CF3)1 (FO6)58 (FP6)128,155 (FP7)27,111 (FQ4)26,59,112 (TG5)57	92 110		910 CRR RBR NR- BR	10-25	237	HM	
3.8.5	4633	(FP7)26 (HA2)12 - (FP6)155	6 110		812 RBR	21	22	HM	
3.8.5	4712	(FP6)154 (FP7)45	110		910	15	6	HM	
3.8.5	4713	(BD2)99 (BE3)10 (JE2)15 gr. 14	110	1137	910 RBR TOP	11-13	39	HM	
3.8.6	2303		67 92 110		CRR	16-23	73	HM	
3.8.6	2321	(AB5)347 (AC6)22 (BD3)16 (BE1)1,63 (BE2)71 (BE3)16 (BF1)6 (JD2)78 gr. 40 (TG5)117	2 67 67C 69 92 94 106		825EW 910 RBR TOP	19-48	88	HM WM SW	

Fig. no.	Type	Provenance	Fabric	Dec.	Surface treatment	Dia.	%	Man.	Comments
3.8.6	2338	(AB4)15 (AB5)43,66 (AC5)79 (AC6)20,22,27 (BD2)63 (BE1)9,41 (BE2)10,48,56,67,103 (BE3)10 (BF1)28,44 (CE4)98 (CF4)1,13,21,75,107 (FN6)3 (JG2)1,224 gr. 244 (TG5)1,5/4,6,12,29 (ZH5)37,42,45	1 56 67 69 80 92 94 94L 95 106 110	1009	820EP 820ER 822R 822W 825IR 825EIR RBRIE RBRI	10-26	527	HM WM	CB
3.8.6	2412	(AD5)0,205 (BE2)100,108 (TG5)22 (ZH5)55	92 94 110	1139	910	18-35	52	HM	
3.8.6	2843	(AD6)5 (FP6)37,57,61,92	92 94 110 110F		806E 910 CRR RBRIE	6-16	71	HM	
3.8.6	2849	1084 2 (AB4)22 (AC5)28,83 (AD5)80,161,255 (CF4)138 (FO6)172 (FP6)57 (FQ4)3 (FR3)13 (FR4)7	2 16 94 110		910 CRR RBRIE RBRIE	10-34	100	HM	
3.8.6	2907	(AC5)34,62,68,85,89 (AC6)77 (AD5)113,134,135,149,154,160,167,19 2,254,259,316 (CE4)9,37 (CF4)62,109 (FN6)6 (FO6)131,180 (FO7)20 (FP6)92,138,171 (FP7)14,152 (FQ4)79 (FR3)22 (FS3)4 (FZ1)12 (FZ2)49 (HA2)79 gr. 197 (TG5)120	48 58 92 92C 94 94C 105 110	200	910 CRR RBRIE	13-28 (45)	247	HM WM	
3.8.6	3107	(CE5)1 (CF3)1 (ZH5)36,37	95 110		910	12-15	89	HM	
3.8.6	3162	(FP6)154 (FT3)1,44	89 92 110		RBRIE	13-17	50	HM	
3.8.6	3172	(FS3)6,11	92 110		910	16-18	10	HM	
3.8.6	3379	(AD5)112 (CF4)17 (CF5)1 (FO6)37,92	94 110		910	17-33	41	HM	
3.8.6	3418	(AC5)68 (CF4)1,113 (CF5)4 (FO6)62 (FP6)34 (TG5)102	92 110	200	910 RBR TOP	14-25	65	HM	
3.8.6	3424	(AC6)13 (CF4)88	110 110C		825EIW	14-20	20	HM	
3.8.6	3451	(CE5)1 (FR3)12	92 110		910	17-25	28	HM	
3.8.6	3456	(AC5)144,162 (AD5)190,207,288 (FO6)2 (FP7)151 (FQ3)9 (FQ4)3,88 (FR3)12 (FR4)7 (TG5)86-99,117,120,154	92 94 110		820IBL 825EIW 910 CRR	15-32	86	HM WM SW	
3.8.6	3464	(FR3)0	9	89g	825EIW	18	14	HM	
3.8.6	3714	(AD5)224,258,287 (CE4)47 (CF3)41 (JC3)8 (TG5)116	25 90 110		825EIW CRR	12-25	102	HM	
3.8.6	3782	(AD5)190,258 (CF4)17 (FO6)47,58,62 (FP6) 144 (FP7)15 (FQ4)2 (FZ2)1 (TG5)12	92 92C 110	200	910 CRR RBRIE TOP	13-33	66	HM	
3.8.6	+3800	(AD5)259,262 296 (FO6)75 (FP8)1 (FQ4)46	92 110		910 CRR RBRIE	13.4-20	140	HM	
3.8.6	4385	(CF4)17	110	1112		13	14	HM	
3.8.6	4454	(CE4)20 (CF4)161	92 92F			10	22	HM	
3.8.6	4503	(CF4)128 (GD3)92 gr. 95	92 110			7-11	18	HM	
3.8.6	4528	(CF5)115	92	1112		10	35	HM	oval?
3.8.6	4589	(CF4)75	92			14	8	HM	deformed
3.8.6	4651	(FP6)72 (FP7)31 (JD2)43 gr. 40	92 110		910 RBRIE	13	12	HM	
3.8.7	333	(AB6)11 (AD5)113 (AD6)5 (BE2)110 (BE4)9,60 (BF1)6,16 (BF3)8	56 69 76 92 94		822R 825EIR RBRIE	15-26	60	HM WM	
3.8.7	2189	(AB4)31 (AB5)46 (BE3)18 (BF3)8 (FQ3)8	1 67 69 92		910 RBRI	19-39	31	HM	
3.8.7	2336	(AB6)24 (AC5)65 (AD5)129 (BE2)110 (BE3)16 (CE4)4 (CF4)55 (FP7)11 (FQ4)59,63 (FS3)13	1 11 69 92 105 110		910 RBR TOP	18-38	94	HM WM	(CF4) deformed

Fig. no.	Type	Provenance	Fabric	Dec.	Surface treatment	Dia.	%	Man.	Comments
3.8.7	2341	(AD5)113 (BE2)10 (BE3)1,10,16 (BF1)39 (CF4)100 (FP6)125 (FQ4)59 (ZH5)15,37	65 67 69 92 94 110		910 RBRIE	18-34	180	HM WM	
3.8.7	2907a	(AB4)27 (AD5)192 (CE4)78 (CF4)17 (FO6)92 (FP6)29,57 (FQ3)9 (TG5)112	92 92C 110		910 CRR	11-24	86	HM WM	
3.8.7	3041	(ZH6)2	-		NRBRIE	28	-	HM	
3.8.7	3102	(FQ4)23 (ZH5)15,44,45	69 92 94		910	18-27	32	HM	
3.8.7	3114	(CE4)48 (CF4)88 (FO6)62 (FP6)144 (TG5)73 (ZH5)37	69 110		910 CRR RBRI	13-27	51	HM	
3.8.7	3123	(FQ3)63 (ZH5)37,38	110	lug	CRR	17	10	HM	
3.8.7	3238	(AC5)79,131 (AD5)28,80,93,167,227,230,316 (CE4)86 (CF4)17,26,109,132 (FO6)61 (FO7)77 (FP6)34,89,97,128,138,188 (FP7)17 (FQ3)69 (FQ4)(FR3)0,12 (FR4)1 (TG5)4	92 94 94C 110	96g,243g 200	910 CRR RBRIE	14-30	341	HM	
3.8.7	3276	(AC5)49 (AD5)149,160,168 (CF3)6 (FO6)15,90,98 (FP6)34,89,128,138 (TG5)154	67 69C 92 94 110		820IR 910 CRR	16-37	164	HM SW	
3.8.8	2557	(BE2)78 (CE5)6	1 94		822R	23	10	HM	
3.8.8	2564	(AB5)32,234 (AC5)78,174 (FP6)156 (FP7)2	67 92 94 110	1204	910 RBR TOP	13-31	50	HM	
3.8.8	3170	(CE4)34 (CF4)112 (FN6)2,3 (FO6)13,66,118 (FP6)5 (FP7)2 (FQ3)9,26 (FQ4)7,88 (FS3)1 (TG5)9,44,100	92 110 110L	1123 1134	825E1W 910 RBR TOP RBRIE	16-33	91	HM WM SW	
3.8.8	3399	(AC5)64 (AD5)184 (HA2)79 gr. 188	48 92C 110	1134		24-32	26	HM	
3.8.8	3409	(AD5)0 (CE4)1,7,14 (CF4)75 (FP6)151 (FP7)12,82 (FQ3)4 (FO4)7 (FR3)0	92 110		910 RBRIE	15-27	80	HM	
3.8.8	3454	(AD5)256 (CF4)1,88 (FO6)5,90 (FP6)9,89,111,144,154,159 (FQ3)42,59,69 (FR3)12 (FR4)9 (JG2)1 (TG5)12,94	92 110		910 RBR TOP RBRIE	12-25	160	HM	
3.8.8	3851	(AC5)128 (FO6)109 (FP6)57,125	110	1143	R8051 910 RBR TOP RBRIE	23-25	42	HM	type often oval
3.8.8	3920	(FO4)63 (TG5)112	105 110	1017		18-31	20	HM	
3.8.8	4169	(FO6)154	92		825EBL/ SOOT?		100	HM	
3.8.8	4255	(TG5)73	92			12	10	HM	
3.8.8	4500	(CF4)138 (FP6)153 (FP7)117	92 110	1112	822R/BL 910	16-23	24	HM	
3.8.9	3657	(TG5)18	105			30	5	WM	
3.8.9	4350	(BE2)14 (CE4)1,9,11,15,20,37,40,48 (CF3)5,41 (CF4)1,7,21,62,65,73,132,142,145,161,162 (CF5)4 (TG5)1,6	12 67 69 92 92C 94 94C 110	1012 1242 boss	825IP 825E1BR	20-35	271	HM WM SW	
3.8.9	4351	(CE4)1,4,19 (CF3)5,49 (CF4)1,10,17,51,112	67 69 92 92C 94 94C	1012 831EW		23-35	83	HM WM	
3.8.9	4352	(CE4)85 (CF3)1 (CF4)26,67,75 (TG5)5/4	69 92 94 110			16-35	66	HM WM	
3.8.9	4374	(CE4)4,81	92 110		RBR TOP	22-23	11	HM WM?	

Fig. no.	Type	Provenance	Fabric	Dec.	Surface treatment	Dia.	%	Man.	Comments
3.8.9	4383	(AD5)87 (CE4)20 (CF3)14,22,26 (CF4)17,25,51,57,112 (TG5)5/4	67 92 94 110		820IR RBR TOP RBRIE	18-40	118	HM WM SW	
3.8.9	4386	(CF3)5,24 (CF4)10 (TG5)5/4	92 110			24-30	31	HM SW	
3.8.9	4391	(CE4)37 (CF4)20,37,95,132 (CF5)2	67 94C 106 110		820ECCR	28-32	31	HM WM SW	
3.8.9	4420	(CE5)2	110			26	9	HM/ SW	
3.8.9	4456	(CE4)42	92	162g		28	7	HM/ SW	
3.8.9	4462	(CE4)37,86,98 (CE5)5	92 94 94C			20-35	44	HM SW	
3.8.9	4463	(CE4)37	94L			21	8	SW	
3.8.9	4471	(CE4)9 (TG5)4	94 110		825IR	30-32	22	HM	
3.8.9	4524	(CF4)74	110			20	9	HM	
3.8.9	4526	(CF3)22	94			22	7	HM/ SW	
3.8.9	4530	(CF4)109	110	850 x 2		31	17	HM	
3.8.9	4536	(CE4)85	92C			21	10	HM	
3.8.9	4547	(CE4)48	94	850		33	10	HM	
3.8.10	2642	(AB4)14,23 (AC6)37 (AD5)134 (CF4)50,67,151 (FN6)6 (FO6)99,109 (FS3)14 (JG2)202 gr. 175 (ZH5)37	11 67 80 92 94 110 110C		910	8-43	112	HM WM	
3.8.10	3354	(AD5)167,241	89 110		910	30-32	11	HM	
3.8.10	3651	(TG5)18	67			37	12	HM	
3.8.10	4355	(CE4)1,23,37,42,58,82,85,86,98 (CF3)2,20,41 (CF4)13,17,55,57,65,101,111, 117,133,159 (CF5)4 (JC3)- (JD2)43,-51 gr. 40 (JD3)16 (JG1)48 gr. 31 (JG2) 178,182,183 gr. 150	92 94 94L 105 110 110C		910 RBR TOP	15-35	226	HM SW	
3.8.10	4372	(CE4)4 (CF3)1	110		910	22-26	38	HM	
3.8.10	4384	(CE4)48,85 (CF4)17,88,132 (CF5)4 (TG5)4	92 94 110		825EIBR 910	17-33	49	HM SW?	
3.8.10	4397	(CF4)26 (TG5)4	110			22-27	18	HM	
3.8.10	4415	(CF4)13	110			30	7	SW	
3.8.10	4436	(TG5)1	69			32	7	SW	
3.8.10	4450	(CE4)23	110			21	5	HM	
3.8.10	4468	(CE4)15	110		910	23	6	HM	
3.8.10	4507	(CF4)139 (FP6)169 (JG1)48 gr. 41	110			23-27	33	HM	
3.8.10	4519	(CF3)31,41	92 110			18-26	12	HM	
3.8.10	4548	(CE4)48	92			30	4	HM	

Fig. no.	Type	Provenance	Fabric	Dec.	Surface treatment	Dia.	%	Man.	Comments
3.8.10	4559	(CF4)99,141,145,155 (TG5)44	92 110	179g	910	21-31	72	HM	
3.8.10	4560	(CF4)145,161	110			26	19	HM	
3.8.10	4580	(CF4)99	106			30	5	HM	oil soaked
3.8.10	4581	(CF4)99	106			29	14	HM	
3.8.10	4790	(GD3)34 gr. 38	94			30	11	WM	
3.8.11	2227	(AB4)10 (AC5)73 (AC6)14,22,30,40 (AD5)249,287 (BD2)40 (BE2)48 (BE3)1,10,18,27 (BE4)14 (CF4)117 (CE5)1 (FP7)19 (FQ4)37 (FR3)1 (FS3)2,34 (HA2)45 - (TG5)9,115	1 65 67 69 71 92 94 110		820IR 822R 825IW 910 RBR TOP	19-47	181	HM WM	
3.8.11	2257	(AB4)10,15,20 (AB5)273 (AC6)40 (AD5)61,134,151,227,278 (BE3)10,21,26,27,49,55 (CF4)1,101 (FO6)34,37,71,92 (FP7)82 (FQ4)116 (FR3)2,13 (FS3)2	1 67 69 92 94 110	850 x 1	820I 825EICR 825EW 910 RBR TOP	15-36	491	HM WM SW	
3.8.11	2699a	(AB4)23 (CE4)15 (CF3)24 (CF4)133 (FO6)114,121 (TG5)5/4	92 110		825EW 910	17-25	101	HM WM	
3.8.11	3692	(CF4)18 (JG1)19 (JH3)57 gr. 36	92 94C 110F		822R	15.5-18	77	HM HM / SW	
3.8.11	4172	(FP6)3	92C			17	28	SW	
3.8.11	4196	(FP6)57	110		910 RBR TOP	25	120	HM	
3.8.11	4401	(CE4)11 (CF3)8,26,49 (HA2)12 - (JC3)2 (TG5)5/4	70 92 110	141g 142g	810I	11-25	52	HM	
3.8.11	4410	(CF4)62 (JD2)43 gr. 40	92 110		910	15	12	HM	
3.8.11	4469	(CF4)59,96 (JD2)51 gr. 40	92 105 110		H825IR	14-37	23	HM	deformed
3.8.11	4523	(CE5)6 (FZ1)24	110			20-28	16	HM	
3.8.11	4641	(FP6)92	110		RBR TOP	7	10	HM	
3.8.11	4642	(FO7)25	92			16	15	HM	
3.8.11	4757	(FO7)69 (FZ1)12	110		820EGR 910	28-34	20	HM	
3.8.12	2275	(AB5)200 (AD5)287 (BE1)18 (BE3)18,55,113 (CF3)1,41 (FP7)30 (FQ4)8 (FT3)1	1 67 92 94 110		820I 910 RBR TOP RBR IE	20-36	103	HM	
3.8.12	2285	(BE3)53 (FN6)3 (FR3)14 (TG5)1,7,94	67 92 110		RBR TOP	27-45	38	HM SW	
3.8.12	3433	(FS3)13 (TG5)57	110			28	5	HM	
3.8.12	3442	(AD5)219 (FS3)4	71		820IW	27-60	6	HM	
3.8.12	3446	(AD5)249 (CF4)113 (FP6)92 (FQ4)2 (FS3)6 (FZ1)10 (TG5)6	92 92C 94 110	1229	910 RBR TOP	19-44	64	HM	
3.8.12	3447	(FR3)13 (FS3)6	110		910 RBR TOP	25-31	14	HM	
3.8.12	3549	(FT3)3	110		RBR			HM	
3.8.12	3702	(AD5)212,227 (CF4)1,88 (FO6)109 (TG5)12,119	71 92 92C 110		820IR 910	19-35	41	HM	
3.8.12	3721	(AC5)92 129 (AD5)225,242 (CF3)1 (CF4)1 (FQ4)35,80	11 92 92C 110		910	25-45	181	HM	
3.8.12	3753	(AD5)239,258 (FO7)36	92 110		RBR TOP	30-42	26	HM	
3.8.12	3809	(AD5)258	110		RBR TOP	29	5	HM	
3.8.12	3809a	(AC5)89	110		RBR TOP	22	6	HM	
3.8.12	3836	(AC5)124 (BE3)57 (CF4)69,133	67 110		910 RBR	20-30	29	HM	rim notches

Fig. no.	Type	Provenance	Fabric	Dec.	Surface treatment	Dia.	%	Man.	Comments
3.8.12	3902	(CE4)14,20 (FQ4)35	110		820IR RBR TOP	17-32	17	HM WM	
3.8.12	3936	(CE4)4 (FO6)11,28	110		910	34-35	26	HM	
3.8.12	4393	(CF4)20	110			13	7	HM	
3.8.12	4413	(CF3)14	110			20	6	HM	
3.8.13	2205	(BC2)4 (BD4)17 (BE1)18 (BE4)1,14,22 (CF3)41 (FQ4)20 (FR3)0	56 67 92 110 110F		Y OCHRE EXT	19-29	53	HM WM	
3.8.13	2266	(BE3)26,30 (BE4)12 (CF3)8	1 56 69 92	850	820IP 825EP	20-29	34	HM WM	
3.8.13	2307	(AC5)37 (BE2)88,145 (BF3)38 (CF4)188 (TG5)74-90,102-105	2 67 92 110	appliqué?	910 CRR	17-31	46	HM	
3.8.13	2348	(AB4)10 (AB6)9 (BD3)16 (BE2)51 (BE3)17 (CE4)78 (CF3)31 (CF4)17	1 2 67 92 110	5 1017 1112 931E	820IR 910 RBRI	16-33	216	HM	
3.8.13	2471	(AD5)168,279,288 (BE3)10 (FP6)57 (FQ4)23 (FR4)7 (FZ2)1	67 92 94 110	1032 1143	RBR TOP RBRIE	21-29	67	HM	
3.8.13	3063	(AD5)1,236 (CE4)1 (FR3)14	67 94 110	dribble/GR??	910 RBR TOP	25-43	37	HM	
3.8.13	3345	(AC5)77,112 (AD5)161,186 (CF3)49 (CF4)1,88 (FQ4)2	1 2 49 77 88 92C 110		910	24-35	43	HM	
3.8.13	3475	(AD5)207 (CF5)1	67 92			21-25	38	HM WM	
3.8.13	3771	(AC5)82 (AD5)217 (FN6)3 (FP7)12 (TG5)6	94 110		825EI 910 RBR TOP	22-41	28	HM SW?	
3.8.13	3776	(AD5)246 (CE4)19,98 (CF4)96 (FO6)59,116,157 (FZ2)29 (GD3)34 gr. 38 (TG5)65,74,100,115	92 92C 110		910 RBR TOP	21-34 (50?)	103	HM	
3.8.13	3778	(AD5)249 (CE4)42 (CF4)139 (FN6)2 (FP6)57 (FZ2)1 (TG5)18,65,73	67 92 94C 110		910 RBR TOP	20-40	54	HM	
3.8.13	3848	(AC5)134 (FP6)1 (FP7)12 (FQ3)58,59 (TG5)73	89 92 110		910 RBR TOP RBRIE	24-42	84	HM	
3.8.13	4085	(CF3)1 (FP6)34 (TG5)103	92 110			14-30	40	HM	
3.8.14	2094	(AD5)161A (BE3)1	65 92C	1006	830IR 910	18-32	12	HM	
3.8.14	2458a	(AB5)59	12	1003 1066	820EW	60	5	HM	
3.8.14	2567	(AB5)32	92	1040	820IR	40	5	HM	
3.8.14	2828	(AC5)79 (AC6)22,27,31 (AD5)60, 214 (FP6)137,144 (FQ4)2	67 92 110	1068	910 RBR TOP	21-33	126	HM	
3.8.14	2853	(BD2)71	67	1066	822W	40	8	HM	
3.8.14	3173	(AD5)87 (FO6)121 (FP6)9 (FS3)11	63 92 92C 110		820IR RBR TOP	17-34	36	HM WM	
3.8.14	3267	(AC5)37,45	92	1129	RBR TOP	36	15	HM WM	oval
3.8.14	3342	(AD5)154 (FP6)56	94 110	1000	820IW	25	17	HM WM	

Fig. no.	Type	Provenance	Fabric	Dec.	Surface treatment	Dia.	%	Man.	Comments
3.8.14	3346	(AD5)161,249 (FQ4)6	69 94F 110	appliqué scar	RBR TOP	21-25	14	HM WM	
3.8.14	3357	(AD5)167,246	94C 110	lug/R	RBRI	25-26	13	HM	
3.8.14	+3756	(AC5)117 (CE4)1 (FQ3)9 (TG5)73	69 92 94 113	1066?	822R 825EIR RBR TOP	12-35	34	HM WM	
3.8.14	+3756a	(AD6)19	110	1066	RBRIE	17x24	55	HM	oval
3.8.14	3763	(AC5)77 (TG5)1	67 92	1066		30	20	HM	CB
3.8.14	+3794	(AD5)273,278	110		910 RBRIE	18	54	HM	oval
3.8.14	3964	(FO7)73 (FQ4)23	110	851		17-21	10	HM	
3.8.14	4292	(FP6)1 (FP7)1 (FZ2)1 (TG5)52	94 110		ABR 820? RBR TOP	21-32	15	HM WM	
3.8.15	2082	(BD2)94 (BF2)33	67 94			23-27	19	HM	
3.8.15	2418a	(BE3)1 (CF3)2 (FR3)2 (TG5)1	67 92 94		822P RBR TOP	24-35	26	HM WM	
3.8.15	2432	(BE3)27 (CF4)26 (FQ3)8 (ZH5)45	67 92 110	boss	820IBR	23-34	42	HM	
3.8.15	2460	(AC6)17 (AD5)161 (BD2)94 (BE3)10 (FT3)1 (TG5)7	67 92 94 110		820I	20-38	47	HM WM	
3.8.15	2513	(AB6)10 (BE2)52	9 69			15-35	22	HM WM	
3.8.15	2728	(BD3)1 (BE2)147 (CE4)14 (CF4)1,65 (FO6)15 (FR3)2 (GD3)1 (TG5)1	66 67 69 92 94 105 110		820EW 825EIR 825E1W	14-30	64	HM WM SW	
3.8.15	3115	(CF5)1 (FR4)9 (ZH5)37	67 110		910 RBRIE	15-31	51	HM	
3.8.15	3796	(AD5)273	71			50	4	HM	
3.8.15	3885	(AC5)145	67	oblique banding		44	17	HM	CB
3.8.15	3940	(FP6)24 (FQ4)26	92 110		910 RBR TOP	30-45	18	HM	
3.8.16	1273	(BE3)53	12			11	10	HM	
3.8.16	2106	(BE1)26 (BF3)53 (FP6)34 (FQ4)64 (JG2)1	1 94 110		910 RBRI	17-30	36	HM	
3.8.16	2247a	(S33)23	1	53g	910	25	9	HM	
3.8.16	2936	(AB4)23,31 (AB5)233 (AD5)192 (CE4)29	69 92 92C 94 110		910	14-20	199	HM WM	
3.8.16	2990	(AB4)23 (AC5)23 (AD5)224,230 (CE4)1,47,71 (CF4)117 (FO6)91 (FP6)21 (FP7)150 (FQ3)8 (TG5)102	3 69 71 94 110	1142	825IR 910 RBRIE	12-40	170	HM WM	
3.8.16	3192	(AC5)105 (AD5)135,294 (CF3)20 (FP6)90 (FP7)34 (FT3)44 (TG5)102,114	58 67 71 92 110		910 RBR TOP	21-39	50	HM	
3.8.16	3436	(BE3)106 (CE4)14 (CF3)2 (CF4)30 (FS3)11	94 110		820IR 910	18-26	31	HM	
3.8.16	3449	(AC5)129,134 (AD5)256 (CE4)58 (CF3)11 (CF4)7 (CF5)2 (FO6)134 (FP6)74 (FP7)14 (FR3)4 (TG5)94,120	92 94 110		910 RBR TOP	14-26 (40?)	83	HM	
3.8.16	3499	(AD5)227,232	110		R805I 910 RBRIE	22	52	HM	

Fig. no.	Type	Provenance	Fabric	Dec.	Surface treatment	Dia.	%	Man.	Comments
3.8.16	3716	1098 2 (AC5)1,99,116 (AD5)224,235,239,258,276,283,287,288 (CE4)71 (CF4)1,20 (FO6)37,89,93,98,122,125,132,138 (FO7)1,25 (FP6)4,9,21,24,28,57, 60,89,128,138,143,151,154,156 (FP7)10,21,23,95,171,191 (FQ3)58 (FQ4)59 (FZ2)1 (GD3)113 gr. 112 (JG2)182,183 gr. 150	92 92C 110	200 1017 1142	910	11-35	598	HM	some deformed
3.8.16	3860	(AB4)- (AD5)282,283,296,298,309,311 (CF4)17 (FP6)34,118,128 (FQ4)7 (FR4)9	110		CRR	12-24	215	HM	
3.8.16	3893	(CE4)42 (FP7)1 (FQ3)61 (FQ4)62 (FR4)2,3	92 94 110		910	12-21	197	HM WM	
3.8.16	3909	(FQ3)8 (FQ4)59	92 110F		RBR TOP	13-16	15	HM	
3.8.16	3941	(CF4)50 (FO6)1 (FP6)69,111,143,151 (FQ4)78	110		901 CRR	10-20	74	HM	
3.8.16	3969	(CE4)2,14 (CE5)2 (CF4)56,107,132 (CF5)1 (FP6)9,60 (FP7)21 (FQ4)48 (JC3)8 (JD2)26 gr. 12,43 gr. 40	25 67 110		910	10-26	229	HM	
3.8.16	4414	(CE4)32,85 (CF3)11	110	158g	910	19-25	34	HM	
3.8.16	+4570	(CF4)75,124	92 110		910	23.5-26	56	HM	
3.8.16	4572	(BE3)1 (CE4)86 (FZ1)2	67 110		910	23-25	19	HM	
3.8.16	4578	(CE4)98 (FP6)171	110			18-28	14	HM	lid?
3.8.16	4590	(CF3)49 (FP6)156	110	V line exterior	910	20	15	HM	
3.8.16	+4656	(FP6)128,154 (FZ2)17	110		CRR	13-19	127	HM	
3.8.16	4691	(FP6)105	110	1142		19	55	HM	
3.8.17	2067	1097 4 (AB4)19 (AB5)248 (AD5)134 (BD2)47,71 (BE1)6 (BE2)71 (BE3)10,18,27,76 (BF1)70 (BF2)32 (CE4)20 (FO6)19 (JC3)8	2 11 65 67 69 72 80 92 110	5	820EO 822R 910 932RE RBRIE	15-37	149	HM WM	(AB4)19 altar fill
3.8.17	2130	(AC5)126 (AD5)126 (AD6)11 (BE2)50 (BE3)10,16,18,27,55,106 (BE4)9,11,14,15,16,19 (BF1)56 (CF4)35,88 (FO6)61 (GD3)125 gr. 119/136	1 9 67 69 83 89 92 94 119	200	910 RBR TOP	20-41	197	HM WM SW	
3.8.17	2224a	(BE4)9	2		910 RBRIE	25	32	HM	
3.8.17	2295	(AB4)6,10,15,23,28 (AB5)58,66 (AC5)127 (AC6)1,17 (AD5)268,272 (AD6)11 (BD3)28 (BE3)10,18,27,31,136 (BE4)15,60 (CE5)1 (CF4)73,191,113,128,142 (FP6)37 (FQ3)24 (FR3)0 (FS3)4 (TG5)5/4 (ZH5)15.36.53,73,85	1 2 25 67 69 89 92 94 95 110		822 825EW 910 RBR TOP	19-40	482	HM WM	
3.8.17	2295a	(AC5)111 (CE4)9,58 (FO6)71 (FP6)9,128,154 (FQ3)48 (TG5)17	92 94 110	1142	825ER 910 RBR TOP	24-35	69	HM	
3.8.17	2314	(BE3)106 (HA2)36 gr. 31	92			24-33	17	HM	
3.8.17	2464	(AB4)22 (AC5)127 (BE3)10 (CE4)1,48 (CF4)88,113 (FO6)160 (FP6)9,70 (FP7)34 (TG5)7,94,127 (ZH5)37,45,55	65 67 92 94 110	1097 1142	825ER 910 RBR TOP	15-38	285	HM WM	
3.8.17	2465	(AD5)289 (BE1)18 (BE3)10 (CE4)14,71 (CF4)101 (FQ4)23 (FZ2)1	11 69 92 110		910 RBR TOP	16-35	51	HM WM	
3.8.17	2466	1083 2 (AC5)92 (AD5)241,258 (BE3)10 (BF1)56 (FQ3)4 (CF4)26 (FS3)11 (TG5)5/4,7,94	67 69 92 94 110		910 RBR TOP	20-35	86	HM WM	
3.8.17	2484	(AD5)276 (FN6)3 (FP6)5,54,57,109,154 (FQ3)8 (FQ4)2	92 110		910 RBR TOP	19-35	120	HM	

Fig. no.	Type	Provenance	Fabric	Dec.	Surface treatment	Dia.	%	Man.	Comments
3.8.17	2497	(AB5)1,22 (AC5)131 (FP7)74	69 92 110		825IR 910 RBR TOP	14-20	32	HM WM	
3.8.17	2543	(AB4)27 (AB5)59,67 (AC5)92,128,129 (AC6)22 (AD5)226,268 (BE2)103 (CF4)51,88,113 (FN6)9 (FO6)61,155 (FP6)5,138 (FQ4)79 (TG5)1,7,74,85,102	69 92 94 110	200	820ER 820IR 825IR 910 RBR TOP	17-49	206	HM WM SW	
3.8.17	2910	(AB4)23 (AC5)78,145 (AC6)36 (AD5)168,215,227 (AD6)16 (FP7)160 (FR3)12 (HA2)79 gr. 197	67 92 94 110	1143	910 RBR TOP	12-45	114	HM WM	
3.8.17	3037	(CE4)1,52 (CF4)155,159 (CF5)4 (ZH5)30,37,44	67 69 94 110		910 RBRI	11-30	145	HM	
3.8.17	3184	(AD5)123 (CE4)20 (CF4)10,88 (CF5)1 (FO6)90 (FP6)37,54 (FP7)12 (FR3)2 (FS3)11,13 (TG5)4,74	92 94 110		820IR 910 RBR TOP	20-46	129	HM	
3.8.17	3457	(BE4)11 (CF3)1 (CF4)69 (CF5)1 (FO6)37 (FO7)73 (FR3)13 (TG5)5/4	11 110		910	16-35	88	HM	
3.8.17	3483	(AD5)217 (CE4)47 (CF3)11 (CF4)13,21,107,112 (FP6)37 138 (FP7)84 (FQ4)49 (TG5)74	92 110		910 RBR TOP	14-33	78	HM	
3.8.17	3799	(AD5)262 (TG5)46	92 105		820EW	15-27	8	HM WM	
3.8.17	3884	(AD5)273 (FP6)9	92C 110		910 RBR TOP	27	15	HM SW	
3.8.17	3913	(CF5)1 (FO6)66 (FP7)21 (FQ4)7 (TG5)94	92 94 110		910	17-31	41	HM	
3.8.17	4499	(CF3)41 (CF4)132 (TG5)4	92 105 110		820IR 910	23-26	22	HM SW	
3.8.17	4579	(CF4)99	92		910	30	7	HM	
3.8.17	4769	(JD2)51 gr. 40	105		910	27	2	HM	
3.8.18	2133	(AC5)116 (AC6)20,36,71 (AD5)242 (BD2)45,99 (BE4)11,13,14 (TG5)74	1 2 11 67 71 72 92 110	1000/R	910 RBRIE	17-33	87	HM WM	
3.8.18	2503	(AB5)32 (AB6)1,24 (AC6)1,4 (AD5)7,84,214,282 (BE1)73 (BF1)16 (CF3)22 (FQ4)62 (JE3)2	19 67 69 92 92C 94 105 110		820R 822 910 RBR TOP	18-50	82	HM WM	(FQ4) crocodile appliqué scar?
3.8.18	2842	(AD5)117 (AD6)5 (FP6)97 (FQ4)21 (FR3)14	67 92 110		820IE 910 RBR TOP	25-41	37	HM WM	
3.8.18	3164	(AD5)236,258 (FP6)92 (FR3)14 (FQ4)26 (FT3)1 (TG5)65	92 94 94C 110		820IR 910 RBR TOP	29-41	56	HM	
3.8.18	3181	(AC5)145 (CE5)1 (FP6)1 (FR3)2 (FQ3)8 (TG5)4,29	92 110		910	20-40	54	HM	
3.8.18	3300	(AD5)12 (CF4)67 (FO6)75 (FP6)56,92 (FQ4)23	69 92 110	200	910 RBR TOP	20-48	59	HM	(FP6) deformed
3.8.18	3425	(AD5)183 (FP6)34	110	1138	825IW 910	30-37	22	HM	
3.8.18	3583	(JH4)- (TG5)18	105		30-41	30-41	4	WM	
3.8.18	3845	(AC5)127 (CF4) (FO7)57	110		RBR TOP RBRIE	13-28	107	HM	oil soaked
3.8.18	4179	(FP6)21,34,49	92 110		910	31-40	90	HM	
3.8.19	2410	(AC5)49,53,92,108 (AC6)34 (AD5)160,207,256 (BE1)1 (BE2)21 (CE4)20 (CF3)41 (CF4)17 (FO6)172 (FO7)1 (FP6)9,97,125,138,179 (FP7)12 (FQ4)2,33,61,90 (GD3)21 gr. 20 (TG5)113	1 69 89 92 92C 94 110 110F 110C	1142	910 RBR TOP	10-50	298	HM WM	

Fig. no.	Type	Provenance	Fabric	Dec.	Surface treatment	Dia.	%	Man.	Comments
3.8.19	2674	(AB4)10,23 (AC5)37 (AC6)54 (BD4)8 (CF3)41 (FP6)31,154 (FS3)11 (ZH5)15	2 67 69 71 92 94 110		820IR 910 RBR TOP	26-49	76	HM	
3.8.19	3315	(AC5)73 (AD5)87,255,272 (CE4)98 (FO6)111 (FP7)74 (FQ4)7	71 92 110		910 RBR TOP	26-40	57	HM SW	
3.8.19	3358	(AC5)107,128,129,145 (AD5)164 (CF4)1,65,107 (FP6)155 (FP7)74 (FQ4)2 (FZ1)9	92 92C 110		910 RBR TOP RBRIE	15-44	100	HM	
3.8.19	3487	(AD5)219 (CF4)30 (TG5)1	110	1 oblique line incised int.	910	17-29	23	HM	
3.8.19	3603	(TG5)46	92			20	4	HM	
3.8.19	3755	(AB5)25 (AC6)22 (AD5)41 (AD6)16 (BD2)26,81 (BD3)32,33 (BE3)10,55,56,59 (BE4)19 (CF4)104,113 (CF5)1 (FO6)58,71 (FO7)73,85 (FP6)9,21,34,54,128,154,188 (FQ3)42,59 (FT3)8 (TG5)74,91	1 8 65 67 69 71 91 92 92C 94 110		910 RBR TOP	(14-17) 23-50	389	HM WM	
3.8.19	3853	(AD5)256 (CF4)88 (FO6)91,109 (FP6)151,154,171 (FQ4)114,115 (TG5)29	92 110		910 RBR TOP	25-48	88	HM	
3.8.19	3921	(FQ4)63 (TG5)4,7	67 94 100		910	25-26	9	HM	
3.8.19	4053	(TG5)73	71			23	22	HM	

3.9. Doka, bread platters, ovens, and flat-based basins

Large coarseware dishes (3.9.1-3.9.4), often with roughly thickened bases are found across the site, and in shape strongly resemble Medieval *doka*. They are not slipped or burnished on the interior, but for the sake of convenience they will be referred to as *doka* here. Whether they were used for making some kind of flat bread, like the modern day *kissera* or *gourasa*, or for frying or in some other cooking process is not known. The dish would at any rate have been heated over an open fire rather than inside an oven – because of the thickening of the base and the fact that no trace of an oven with a large enough opening has been found. It should, however, be noted that the concave nature of many (but not all) of the *doka* would have caused the dough to puddle in the centre of the dish, hardly desirable if something akin to *gourasa* actually was made in them, suggesting that they were used for producing a different food.

Assorted handmade (coil built) basins with piecrust decoration and or lugs (3.9.10).

Two bread ovens have been reconstructed (3.9.12), one complete and one almost, and several rims and bases of others were also found. Bread platters (3.9.6), common elsewhere in Nubia and also in Egypt, occur frequently in some areas (especially Areas A and B); usually they have a diameter of *c.* 23cm, but larger sizes also occur, and others with a much flatter lip, that may have had slightly different uses, such as a platform for dough to rise on, for example. In other instances these large platters may have served as lids for storage bins or ovens.

Crocodile pots and other vessels with appliqué animals. Three or more pots have an appliqué crocodile on the rim (3001x, 3.6.1; 3267x, 3.8.14; 3084x, 3.9.7), and in at least one case a snake (2028x, 8.14). There are several other instances where the remains of the appliqué are too indistinct to hazard an identification, see 8.14. Mostly these forms are oval basins, but in the case of 3001x (3.6.1) it was added to a plain-rimmed, cooking pot like vessel. See also Figure 3.11.10 for other appliqués, including two birds, 3728x and 3801x, and what may be a snake or bird head (3770x), as well as what look like snake tails wrapping around handles (3486x and 3389x, 3.12.5). See also the Small Finds report, Welsby and Taylor *forth.*, cat. nos F-481, F-482, F-484, F-485, F-491 and F-495.

3.9.1 - 3.9.4 *Doka*

These vary from very shallow to a little deeper. They have a smooth rim and interior, while the lower part of the body on the exterior is generally very coarse (similar to the Medieval variants of this type of vessel).

3894x (3.9.3): Laming Macadam 1955, pl. 32 13b (2058), Napatan.

3.9.5 Large platters and/or bin lids

Flat with a raised, rounded rim. Some have radial finger-drawn lines (1082y), similar to brick-bonding grooves, and in at least two instances (2765x and 2995x) there were traces of a central knob, for lifting the lid? Those without this last

feature were perhaps used to ‘rest’ the dough on? See also Nowotnick 2018, fig. 17: very large platters.

2223x and **2323x**: Nu.56 (26, 328-308 BC) fig. 195, 18-2-123.

3.9.6 Bread platters and small basins

Nowotnick 2018, fig. 16, bread platters made of Nile clay. Mohamed Ahmed 1992, 1F2, end of 7th century to mid 6th, through to the end of the 5th century BC. For the oval basins, see Aston 1999, pl. 83, 2268, 4th century BC.

2018x: Boulet 2017, fig. 3.j, 25th Dynasty.

2075x: Mohamed Ahmed 1992, fig. 28 III B8, mid 6th to late 5th centuries BC.

2081x: Orzechowska 2003, pl. 28c, Meroitic.

2603x: Four of these were found complete, leaning against the wall in Room IV of Building A1, phase II-III (Vol. 1, pl. 3.33). Orzechowska 2003, pl. 28a, Meroitic. Probably incorrect dating; this type of utilitarian form has a long life.

2648x: Ruffieux 2007, pl. 3.26 [12 B-49], Nile clay; Napatan.

2891x: Laming Macadam 1955 II, pl. XXXII.13b [2058], Napatan.

3.9.7 Miscellaneous basins

This form often has an oval rim rather than a circular one (cf. e.g. Aston 1999, pl. 83.2268, and this type of basin in the RCK reports).

2105x: Beg. W.584 (7-12? 653-538 BC, although the figure legend says ‘Undated’) fig. M11, 23-3-352.; Nu.34 (23, 397-362 BC) fig. 174, 18-1-454.

2454x: Nu.42 (10, 593-568 BC) fig. 88, 18-1-165, red ware.

+3084x: Oval basin with two crocodile appliqués, see Nu.17 (22, 398-397 BC) 219, fig. 169, 17-3-391 (Rilly says late 5th century BC, but could he be referring to Nu.32?); Nu.32 (19? 453-423 BC) fig. 156, 18-2-413, MFA, 463-435 BC, acc. no. 20.4778; Nu.42 (10, 593-69 BC) fig. 88, 18-1-165, more inverted wall and notched rim decoration. With no decoration, Nu.34 (23, 397-362 BC) fig. 134, 18-1-45. At Sedeinga this form is also recorded, for a fine example see Rilly and Francigny 2018, 5, Napatan basin (II S 065) with crocodile figures on the rim, which is also decorated (a skeuomorphic basketry representation?), with no parallel in the Kawa repertoire.

Note that the drawing was done before the second half of the basin was found, several seasons later. By then the first half had already been taken to the Sudan National Museum in Khartoum, and it was only possible at that time to rejoin the halves and photograph them.

4809x: Laming Macadam 1955, II, pl. 32 13a (2062), Napatan, but wall curving back more.

3.9.8 Miscellaneous basins

Including one with a spout.

+3367x: Unless there was a way to plug the large mouth of the spout adequately, the ‘basin’ can only have functioned as a spout, channeling rather than containing liquids. For a similar vessel, cf. Mohamed Ahmed 1992, fig. 29, pl. xiv, from the potter’s workshop. In the same volume, consider

also the shallow basin I H1 (fig. 23, pl. IV), which has a circular hole near the base, presumably to drain liquids. In Török 1997, II, fig. 115, 924-1 there is an apparently spouted basin, although approximately half the size of 3367x and with painted decoration; the drawing however suggests there is a spout at the level of the base.

4639x: Large oval basin from Area F, associated with Buildings F8 and F9. A good parallel is from Nu.15 (26, 328-308 BC) fig. 192, 17-2-1871, red ware.

3.9.9 Plain rims of thick-walled, coarse inverted rims

Some may belong to bread ovens or storage bins.

311x: A similar rim with a similar decorative moulding (shown in the drawing) was found during the Northern Dongola Reach Survey at Kawa, at (KE) 1202, between the town and site R18.

3.9.10 Thick-walled bin and basin rims

Coil-built. Piecrust decoration and occasional lug handles. While a number of bins (*quseiba*) made of unfired mud have been found at Kawa, some of the rims here had been fired to some extent and are rather different to those of the bread ovens.

3.9.11 Bread oven rims

No published parallels have been found for these, with the exception of 3431x, which in any case may be a storage bin.

3431x: A very similar rim is illustrated in Laming Macadam 1955, II, pl. XXXIII [2070], Meroitic, illustrating a grain storage bin, very much like the (pre-) modern *quseiba*. The example published by Macadam features a circular opening just above the base, presumably to retrieve the oldest grain first, again just like the *quseiba* (Plate 3.9.1). Whether some of our 'bread ovens' are actually part of storage bins is not clear, but where it is certain that they are a cylinder without a closed base they are likely to be ovens. The various

layers of lime coating, present on 3431x and other similar sherds may have been applied to protect grain from damp and insects. Alternately it could have functioned as a kind of non-stick coating in a bread oven.

3.9.12 (Cylindrical) bread ovens

Note string (or wire?) cut marks and finger marks on 2134xa and traces of 200y basket impression on 2890x (height 61cm). The diameters of the two ovens that were found more or less intact *in situ* are the most reliable, 56cm and 53cm. Given the fragmentary nature of the other surviving bread oven fragments, the low diameter estimates should probably be assumed to be incorrect.

4637x: As for 3431x above, see Laming Macadam 1955, II, pl. XXXIII [2070]; see also Nowotnick 2018, fig. 10, for similar items with air holes.

3.9.13 Coarse, large lid handles

2046x: Aston 1999, pl. 65 [1897], similar size though knob is different: 6th century BC.



Plate 3.9.1. *Quseiba* at el-Khandaq.

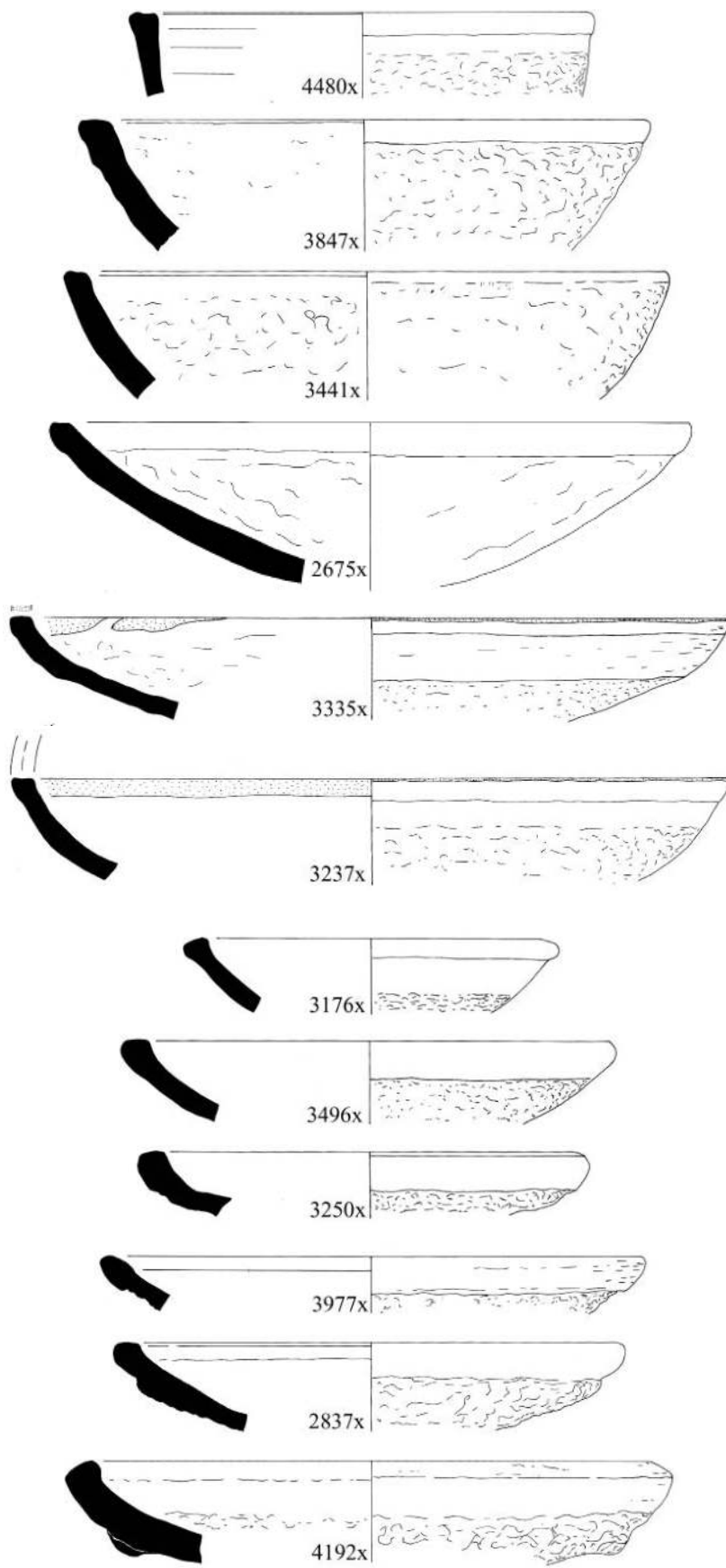

Figure 3.9.1. Doka'-like dishes (scale 1:4).

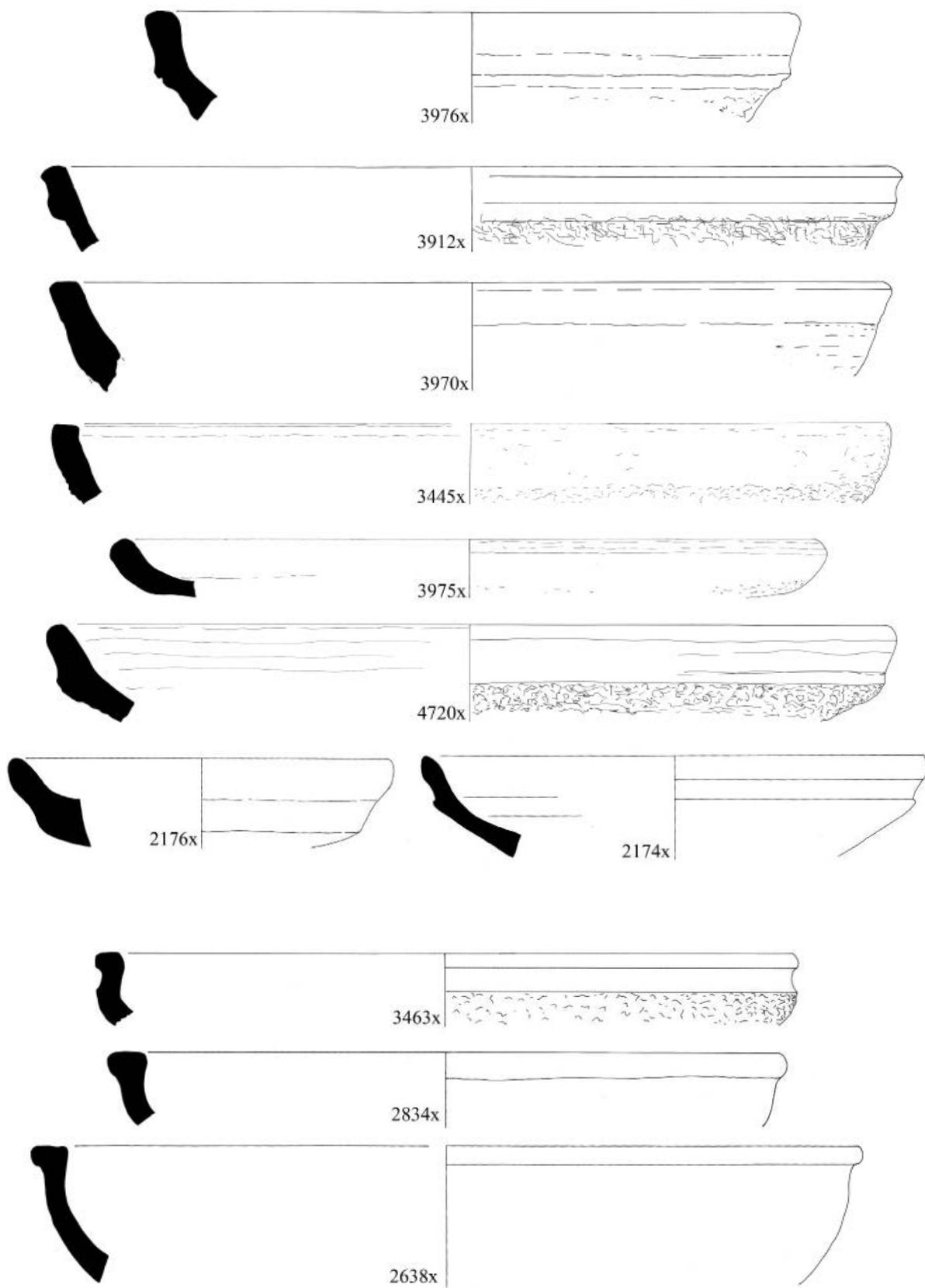

Figure 3.9.2. 'Doka'-like dishes (scale 1:4).

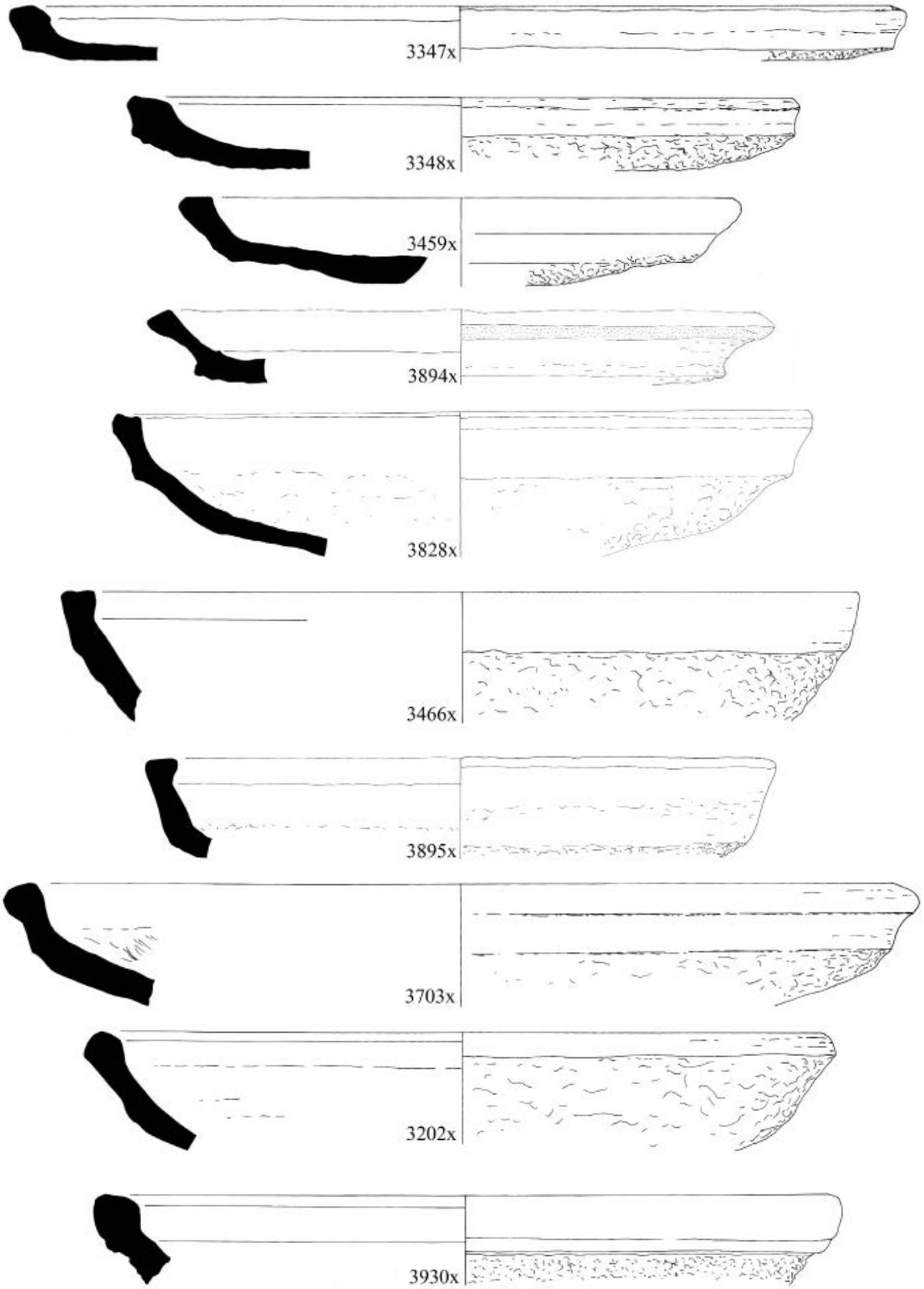

Figure 3.9.3. 'Doka'-like dishes (scale 1:4).

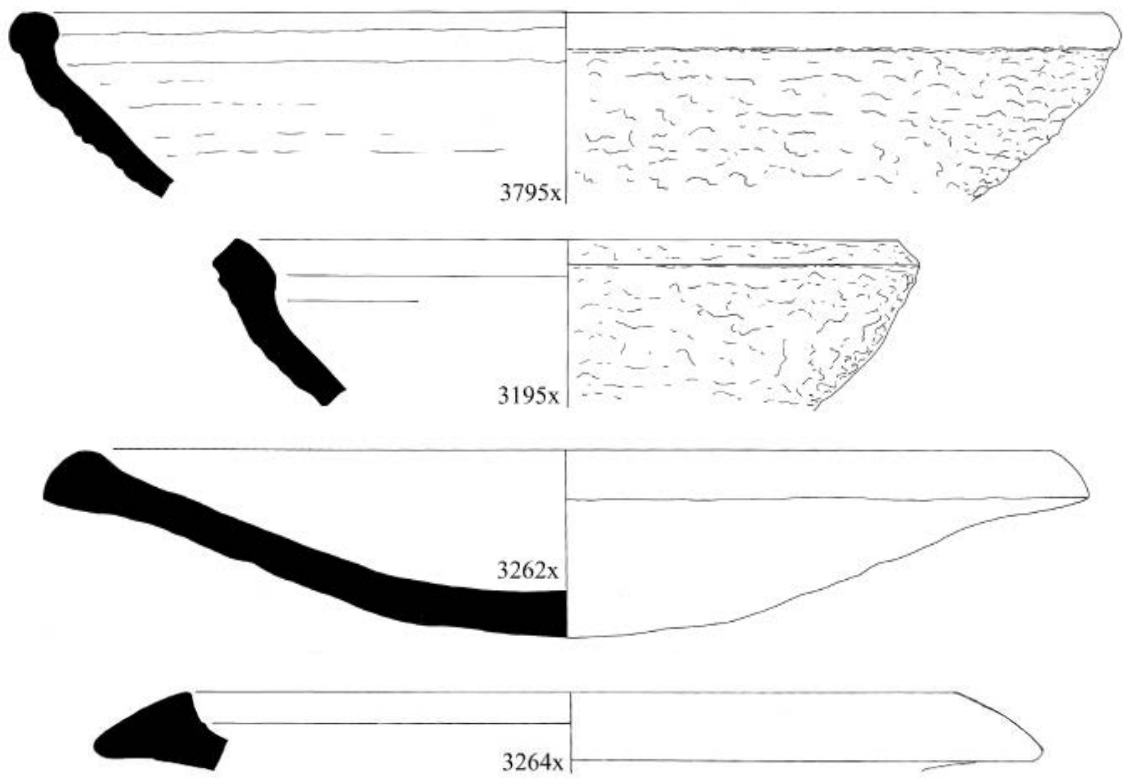

Figure 3.9.4. 'Doka' and miscellaneous basin or bin rims (scale 1:4).

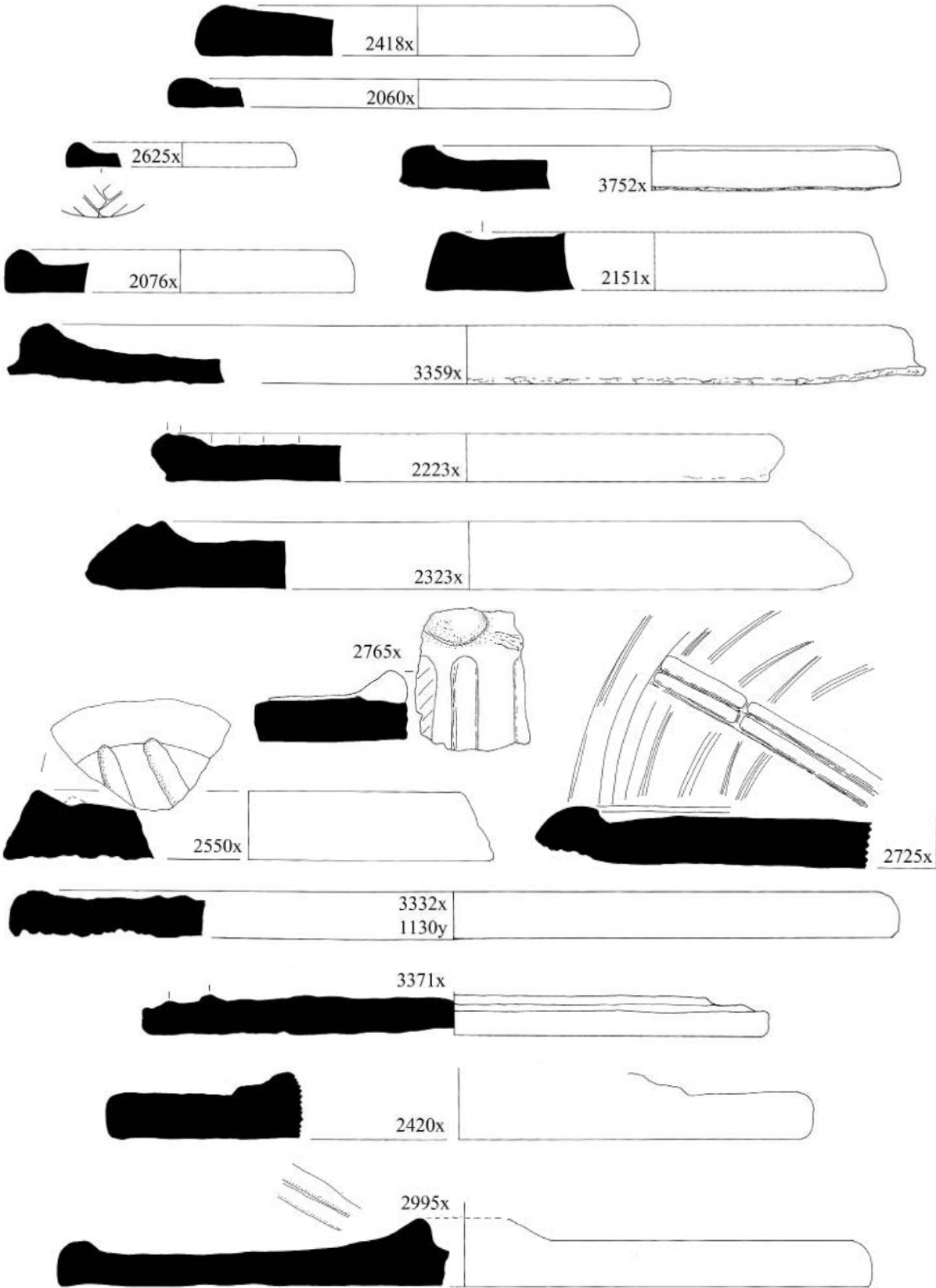

Figure 3.9.5. Large platters and/or bin lids (scale 1:4).

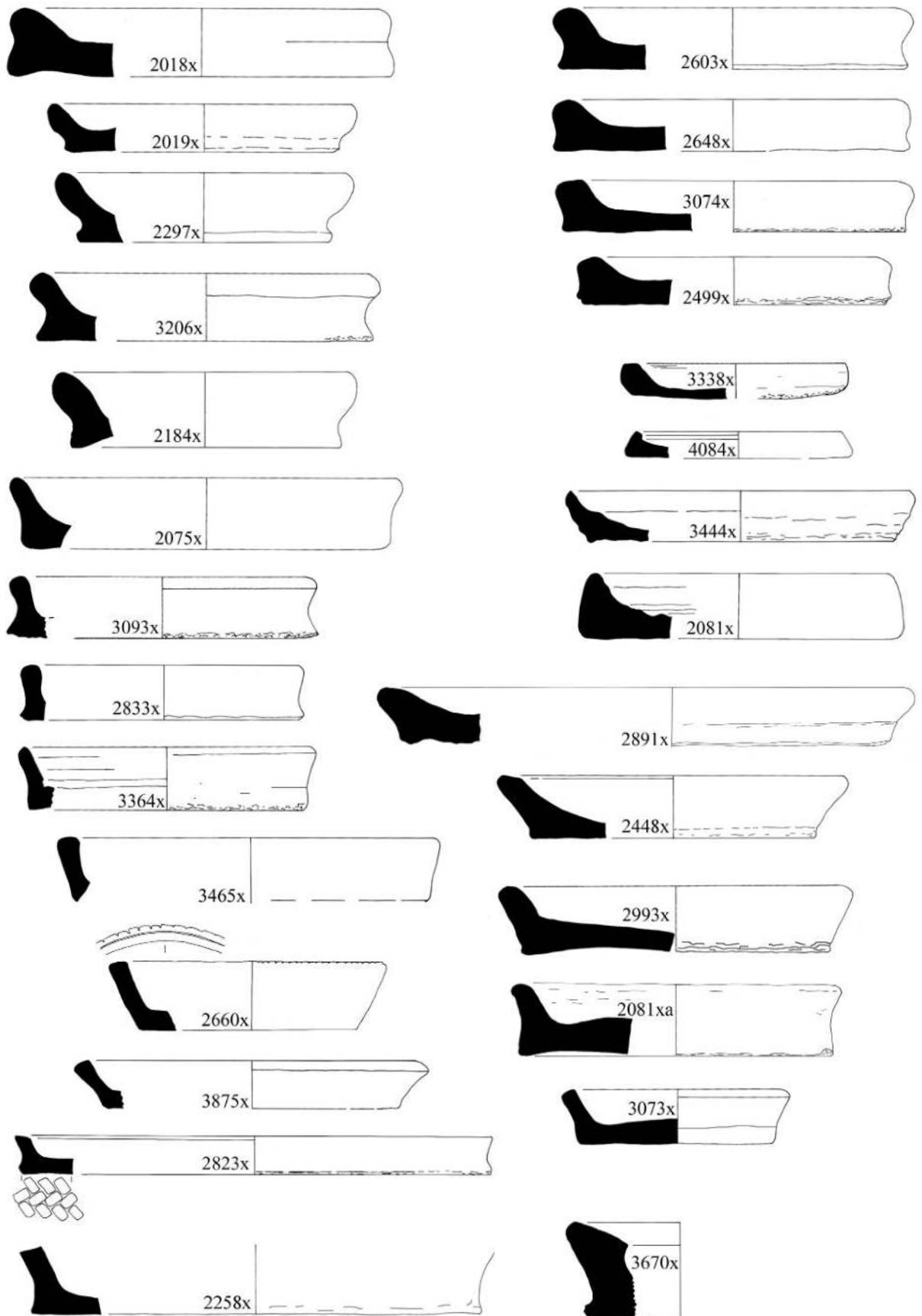

Figure 3.9.6. Bread platters and small basins with flat bases (scale 1:4).

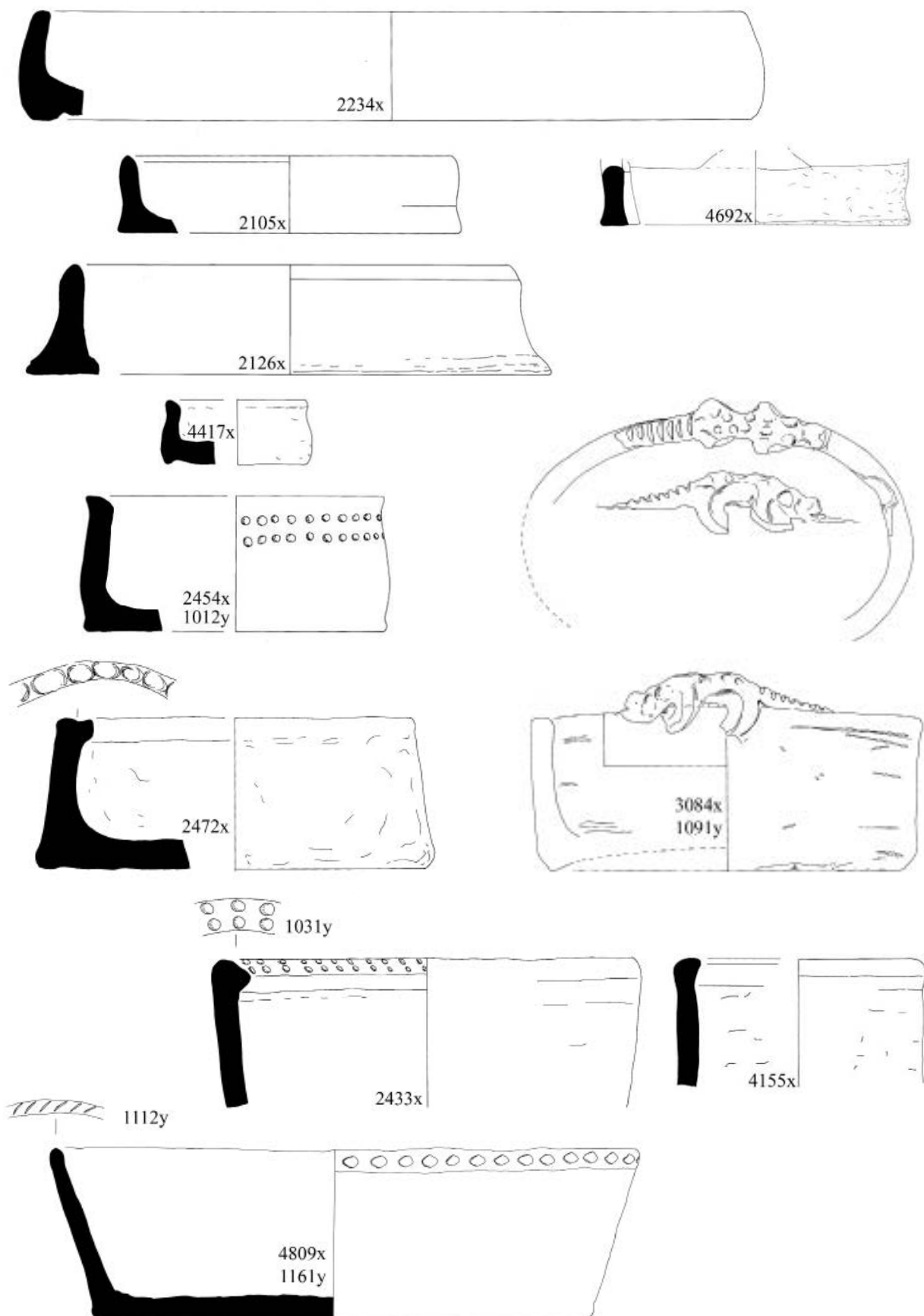

Figure 3.9.7. Basins, some possibly deep bread moulds (scale 1:4).

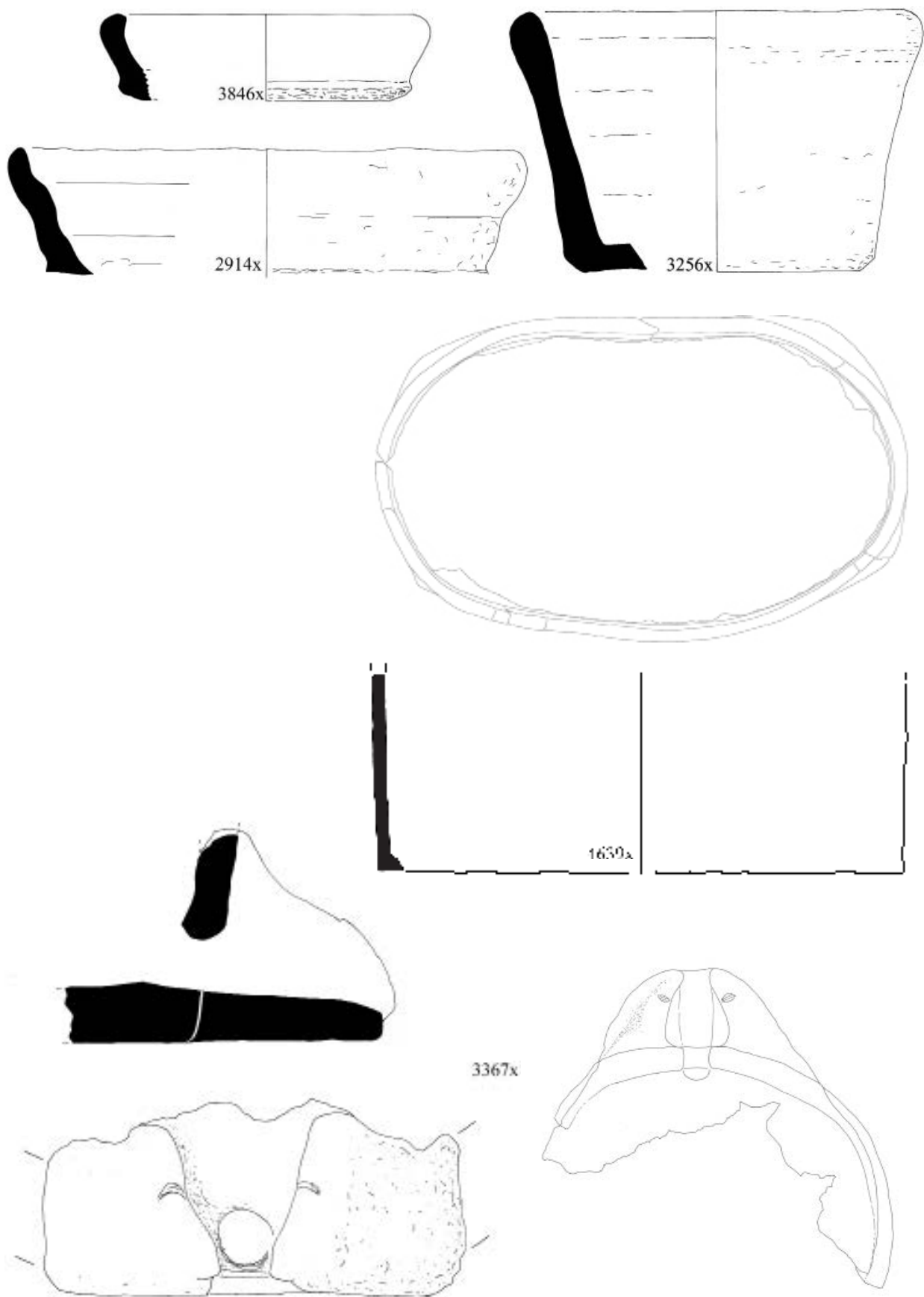

Figure 3.9.8. Oval basin with two crocodile appliquéés. Basin 4639x and spouted 'vessel' 3367x are at scale 1:8, others at 1:4.

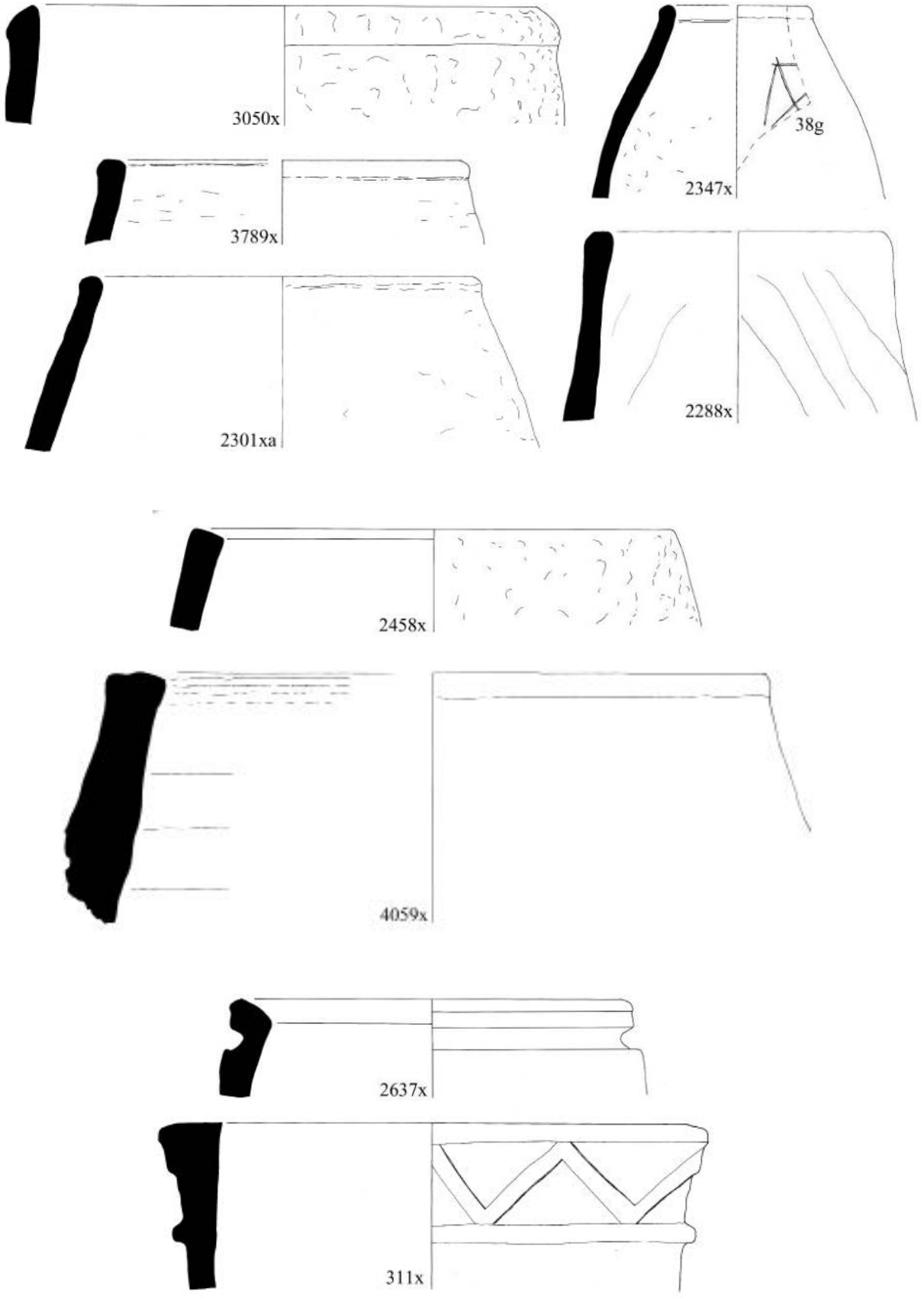

Figure 3.9.9. Bin and coarse bowl rims (scale 1:4).

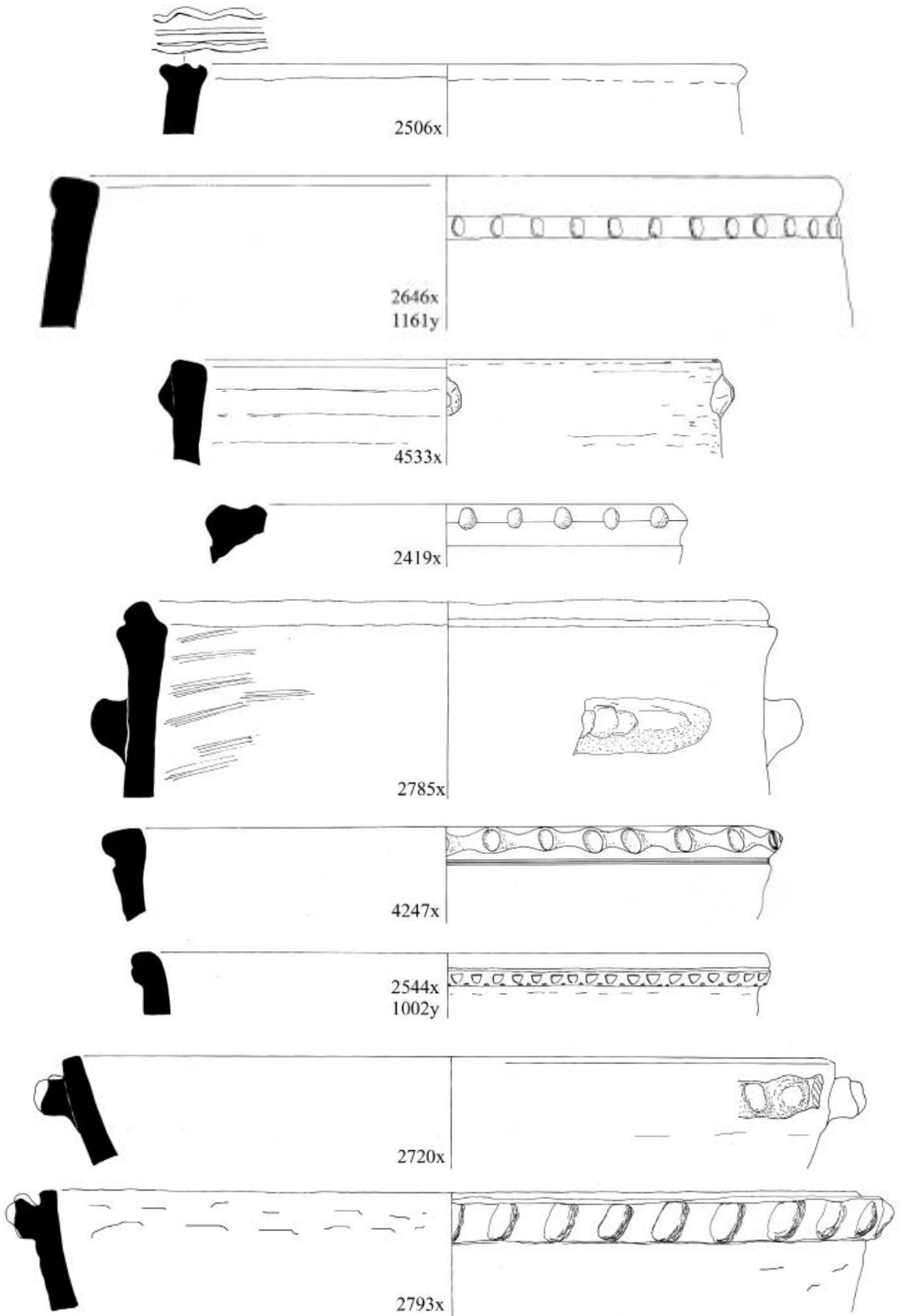

Figure 3.9.10. Bin and basin rims, coil built (scale 1:4).

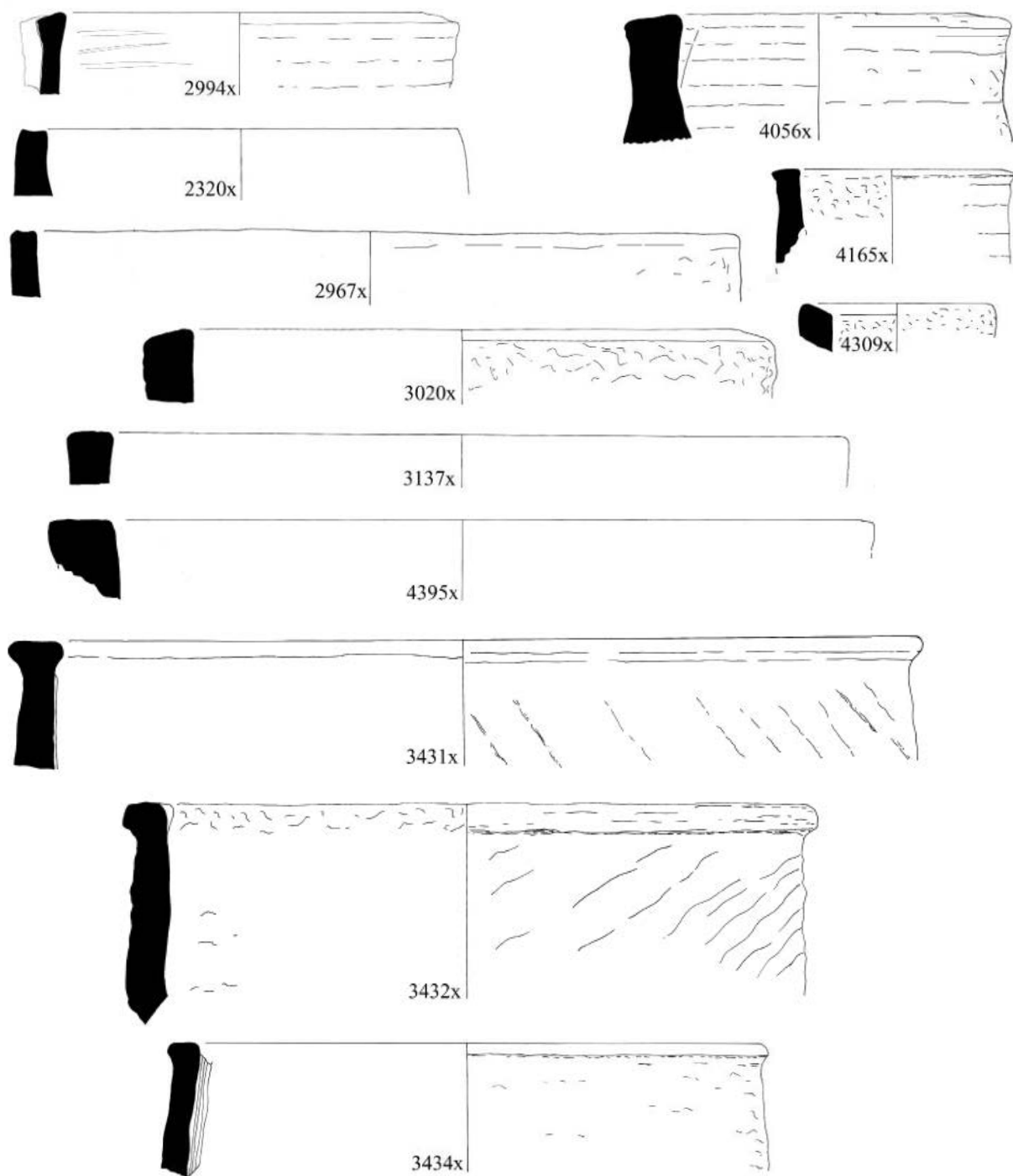

Figure 3.9.11. Bread oven rims (scale 1:4).

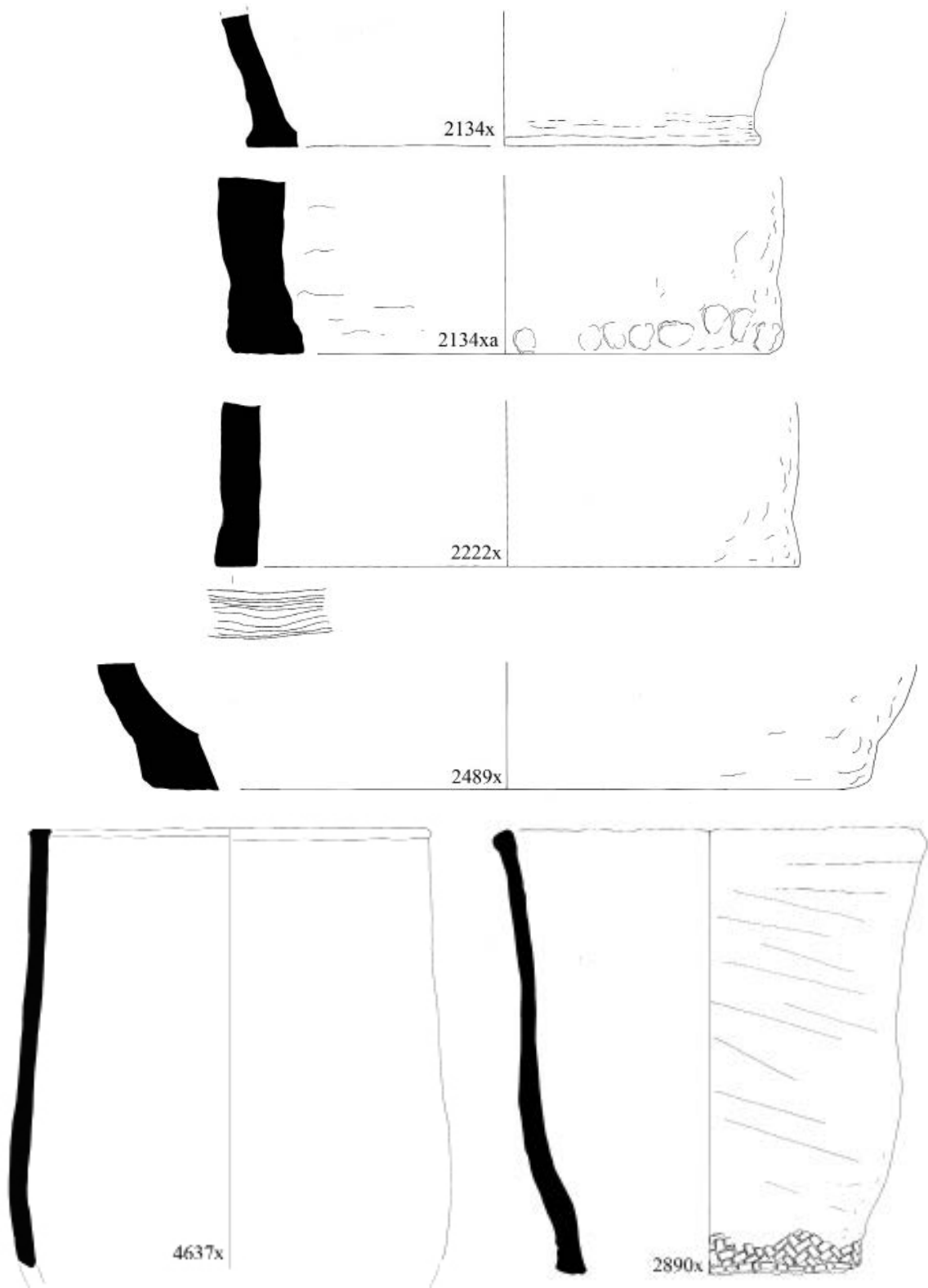

Figure 3.9.12. Bread ovens. 4637x and 2890x are at scale 1:8, others at 1:4.

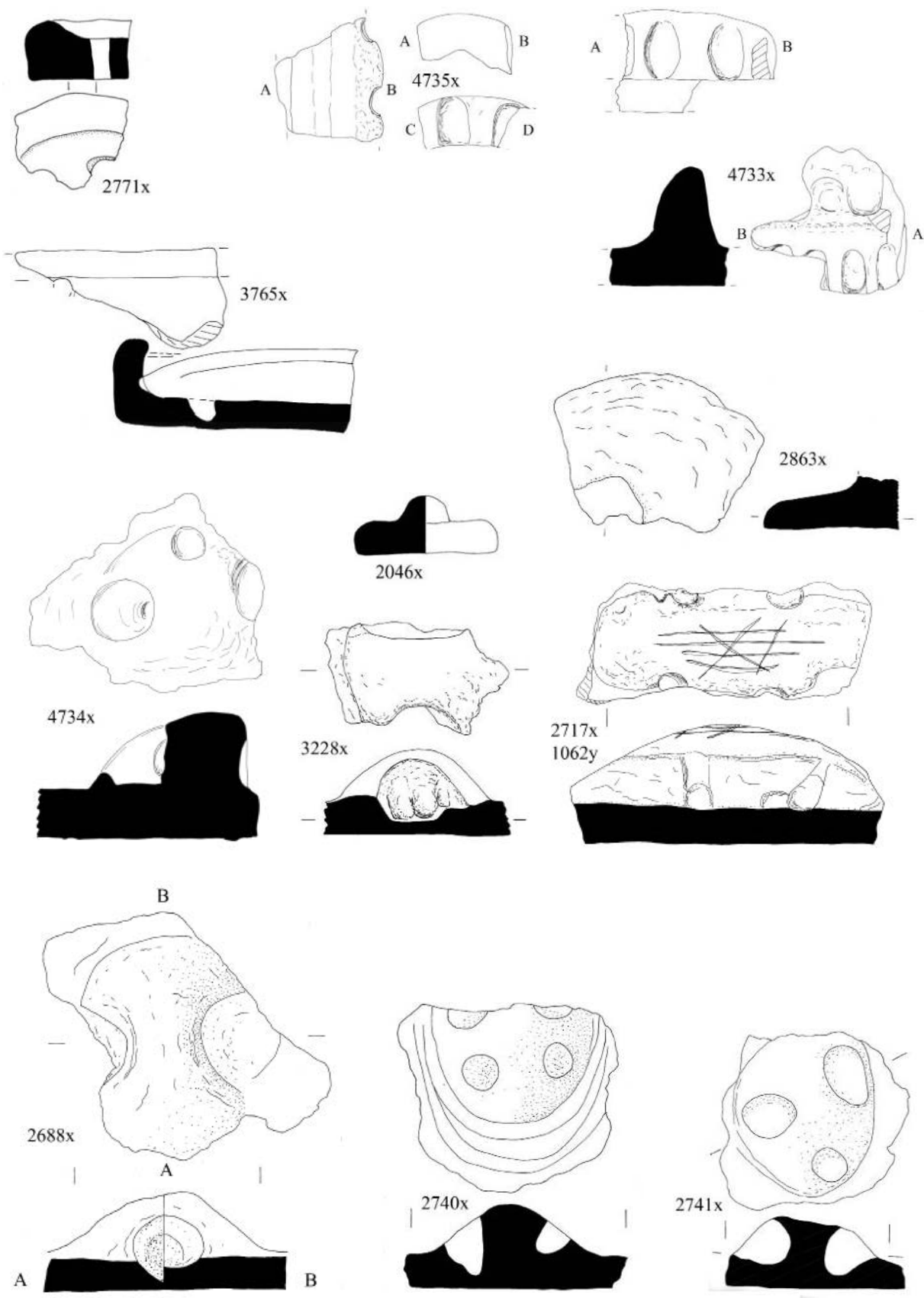

Figure 3.9.13. Large lid handles (scale 1:4).



3828x
3.9.3

Plate 3.9.2. Interior of a doka (3828x), bread-platters (2019x & 3074x), a crocodile-rimmed basin, a spouted vessel and varieties of lid knobs/handles (2717x & 4734x).



2019x

3.9.6

3074x



3084x
3.9.7



2717x
3.9.13



4734x
3.9.13

TABLE 3.9. DOK4, BREAD PLATTERS, OVENS AND FLAT-BASED BASINS.

Fig. no.	Type	Provenance	Fabric	Dec.	Surface treatment	Dia.	%	Man.	Comments
3.9.1	2675	(AB4)10 (AD5)152,161A,259,260 (CE4)85 (CF4)156 (FO6)47,52 (FP6)34,37	2 67 71 92 92C 110		910	13-45	116	HM	
3.9.1	2837	(AB4)23 (AC6)30	71 92			27-32	10	HM	
3.9.1	3176	(AC5)73,128 (AD5)135 224,227,281 (AD6)13 (CE4)9 (CF4)140 (FP6)128 (FR4)7 (FS3)16 (TG5)102	92 110		910 RBR TOP	19-42	95	HM	
3.9.1	3237	(AC5)134 (AD5)28,149,214,224,227 (FO6)47 (FP6)21,34,92 (FP7)6 (FQ3)58 (FQ4)7 (FS3)11	67 71 89 92 94 110	200	910 RBR TOP	18-42	93	HM	
3.9.1	3250	(AC5)28	71			44	7	HM	
3.9.1	3335	(AD5)112,124,129,249 (CE4)4	71 92 110		910 RBR TOP	30-50	26	HM	1 deformed
3.9.1	3441	(AC5)111 (AD5)184 (CE4)1 (FP6)31 (FP7)12 (FQ3)8 (FQ4)2,59 (FR4)1,9 (FS3)4	67 71 89 92C 105 110		825EGR 910 RBR TOP	21-60	74	HM WM	
3.9.1	3496	(AD5)230,276 (FP6)10 (FR4)7	71 92 92C 110		RBR TOP	30-44	23	HM	
3.9.1	3847	(AC5)117,162 (FO6)53 (FP6)3,9	71 92 92C 110			30-52	23	HM	
3.9.1	3977	(FQ3)42	110		910	34	5	HM	
3.9.1	4192	(FP6)37	92C			34	4	HM	
3.9.1	4480	(CF4)65	94			28	9	WM	
3.9.2	2174	(AD5)161A (BE3)67	56 71		825EI	36-60	16	HM WM	
3.9.2	2176	(AB4)23 (AB5)68 (AC5)61 (AD5)1 (BD2)26 (BE4)16 (BF1)28 (BF3)52	21 25 71 92C			22-30	78	HM WM SW	
3.9.2	2638	(AB4)20 (AB5)91,94 (AC6)36	1 92			26-60	14	HM WM	
3.9.2	2834	(AC6)23,40 (FQ4)27	71			49-53	15	HM	
3.9.2	3445	(FS3)6	110			60	7	HM	
3.9.2	3463	(FR3)23	67			50	5	HM/ SW	
3.9.2	3912	(FQ4)7	92C			60	8	HM	
3.9.2	3970	(FQ4)75	92			60	3	HM	
3.9.2	3975	(FQ3)42 (TG5)1,29-105	71 92			23-50	16	HM	
3.9.2	3976	Area A (FQ3)42	92 71			45-47	7	HM	
3.9.2	4720	(FP6)143	71			60	9	HM	
3.9.3	3202	(AC5)99 (AD5)34,273 (FP6)96	71 92		825IW	48-55	20	HM	
3.9.3	3347	(AC5)46,79 (AD5)127,161,249,283	71 92 110			20-60	43	HM SW	
3.9.3	3348	(AD5)160,264 (FP6)128	69 92 92C			46-60	29	HM SW	

Fig. no.	Type	Provenience	Fabric	Dec.	Surface treatment	Dia.	%	Man.	Comments
3.9.3	3459	(AC5)164,170 (FP6)92 (FQ4)23 (FR3)14 (FR4)9 (TG5)65	71 92 92C 110 110C			36-60	72	HM	
3.9.3	3466	(FP6)57 (FR3)0 (FR4)9	71 92 110			55-60	12	HM	
3.9.3	3703	(AD5)227 (FO6)55 (FP6)144	71 92 92C			50-60	20	HM	
3.9.3	+3828	(AC5)131	92	247g		54	21	HM	
3.9.3	3894	(FR4)9	92C			59	6	HM	
3.9.3	3895	(FR4)9 (TG5)74	67 92C			30-60	12	HM WM	
3.9.3	3930	(FQ3)42	71			50	4	HM	
3.9.4	3195	(AD5)20,41	25 71			37	9	HM	
3.9.4	3262	(AC5)38	71			50-60	17	HM	B unfired
3.9.4	3264	(AD5)69,117	71		RBRI	43	7	HM WM	HM unfired
3.9.4	3795	(AD5)269,273	71			60	8	HM	
3.9.5	2022a	(AC5)145 (AD5)160 (BE3)16 (CE4)2,9,11,10,29,47,85 (CE5)4,6 (CF3)13,22 (CF4)1,7,18,75,101,103,111,113,132 (FO6)121,167 (FP6)28,94 (FP7)2 (FQ3)58 (FQ4)37 (FQ4)119G (FS3)2 (JD2)43 (TG5)6,74	2 67 92 92C 94 94F 105 110	110g 1017 1112 1190 1212 1219 1233 850	820ER 820IR 822R 825ER 910 CRR RBRIE NRBRIE	13 -30 (40)	433	HM	1 oval? some have lug on R sooty ext indistinct basket impr under slip
3.9.5	2060	(AB4)5,7,22,23 (AB5)40,86 (AC5)8,13,17,72 (AD5)1,28 (BD2)26 (BD3)5 (BE1)1,41,44,51 (BE2)57,73,157 (BE4)1 (BF1)4,6,28,56,61 (BF2)11,20,32,33,37,51 (BF3)8 (CF4)142 (FO6)91,92 (TG5)1,65,74,102,103,112	1 20 21 66 67 69 71 92 92C		8201W 825EW 832CR	22-60	345	HM WM SW	1 unfired
3.9.5	2076	(AB4)11,23,31 (AB5)1,20,68 (AC5)12 (AD5)1 (BD2)65,81 (BE1)61,73 (BE2)38 (BF2)31 (BF3)50 (CF3)22 (TG5)74	1 20 21 67 67C 69 71 92			21-35 60?	160	HM WM SW	
3.9.5	2151	(BE3)21 (BF1)13 (BE2)37 (BF3)9,50	71			26-48	46	WM SW	
3.9.5	2223	(AD5)28 (BE1)10 (BE3)78 (BF2)1 (TG5)7	25 71 92 94			40-43	20	HM SW	
3.9.5	2323	(AB4)23 (BD2)79 (BE1)96,158 (BE3)16	1 71			45-55	16	SW	
3.9.5	2418	(AB4)6,10,23,31,33 (AB5)20,336 (AD5)1,212 (BD2)49,61,101 (BD3)14 (BE1)18 (BE2)112/ 117 (BE3)10,16 (BF1)6,9,16,28 (FT3)1 (TG5)44	1 12 67 69 71			23-55	167	HM SW WM	
3.9.5	2420	(BE1)48 (BE4)19 (BF1)7	1 71			30-60	34	HM	
3.9.5	2550	(BE1)103,105	71 91C	1082		35-40	15	HM	
3.9.5	2625	(AB5)66 (AD5)93,113 (TG5)73,91,94	1 71 92 92C	200		12-24	46	HM SW	
3.9.5	2725	(AB4)31 (AD5)1 (BD2)26,45 (BE1)70	67 71	1082		45-58	51	HM SW	

Fig. no.	Type	Provenance	Fabric	Dec.	Surface treatment	Dia.	%	Man.	Comments
3.9.5	2765	(AB4)23 (BD3)4 (JG1)-	71 92	1082		-	-	HM	
3.9.5	2995	(AB4)23 (AD5)93 (FO6)172 (TG5)103	71 92 92C	1082 831E		30-58	46	HM	
3.9.5	3332	(AD5)115	71	1082		60	12	HM/ SW	
3.9.5	3359	(AD5)178	94C	1082		58	16	HM	
3.9.5	3371	(AB5)243 (AC5)73,99	67 71 92			31-45	184	HM	
3.9.5	3752	(AD5)223 (TG5)44	92 110			32-50	15	HM SW	
3.9.6	2018	(AB5)68 (BD2)28 (BE3)1,16 (BF1)45 (BF2)1,31 (BF3)8,38	1 21 71			20-32	139	HM WM SW	
3.9.6	+2019	(AB4)1,5,10,11,14,15,22,23,31 (AB5)28,29,41,89,91,94 (AC5)28,37,38 (AD5)1,7,20,67,161A,183 (BC4)2 (BD2)28,29,45,49,50,61,81,82,100,101 (BE1)73,104 (BE3)55 (BF1)6,28 (BF2)1,32,37,51 (BF3)8,27,50 (TG5)102 (AB4)4 (AB5)32,68 (AD5)1,49,87,185 (BC4)2 (BD2)33,49,82,89,96,100 (BE1)63 (BE1)48,67,147,156 (BF1)57,61 (BF2)31 (FO6)129 (FR4)1 (TG5)12,29-105,73,94	1 21 67 71 92 1 12 21 67 71 89 92 92C 94		822W 825IGR	17-29	1501	HM WM SW	
3.9.6	2075	(BE1)12,29-105,73,94	21		822W unusual	15-40	343	HM WM SW	(FO6)129 unfired
3.9.6	2081	(BF2)33	71			23	15	SW	
3.9.6	2081a	(AB4)23				23-24	25	SW	
3.9.6	2184	(AB5)32 (AC5)45 (BF1)9,45 (BF3)15,50 (TG5)102	21 25 81 92		822W	21-34	60	HM WM SW	
3.9.6	2258	(BE1)1 (TG5)6	67			33	10	HM	
3.9.6	2297	(AB5)66,67 (AC5)17,34 (AD5)1,28 (BD2)24,28,32,45,61,65,71,82,87 (BD3)8 (BE1)18,41,49 (BE2)48,53,71,73 (BE3)13 (BF1)4,53,61 (CF4)13 (TG5)103,115 (ZH5)53	1 21 67 71 92		830IR	19-38	390	HM WM SW	
3.9.6	2448	(AB5)32 (AC5)55 (AD5)1 (BE3)18 (BF1)6	67 69 71			23-40	51	HM SW	
3.9.6	2499	(AB4)1,4,5,6,14 (AB5)14,29,68 (AC5)8,17 (AD5)1,20,128 (BD3)5 (BE1)7,61 (BF1)61 (FP6)9 (FR3)2	1 67 71 92 92C			19-40	399	HM SW WM	
3.9.6	2603	(AB4)7,10,11,20,23 (AB5)58 (AC5)28,38,46,49,129 (AD5)12,23,162,28,67,84,87 (BE1)1,49 (BF1)4,61 (FP6)90,92 (FQ3)48 (FQ4)61 (FT3)44 (TG5)4	25 67 71 92			15-40	964	HM WM SW	
3.9.6	2648	(AB4)6,7,23 (AC5)12,38,45,46 (AD5)1,7,28,49,73,93,99,161a (BF1)6,61 (BF2)51 (TG5)1,12,44,73,89,94,102	21 71 92 92C		822	21-28 (40,58)	447	HM WM SW	
3.9.6	2660	(AB4)7 (FQ4)23	12 94			21-24	25	HM	
3.9.6	2823	(AB4)33 (AC5)78 (AC6)20 (AD5)28 (BD2)101 (TG5)94	71 92 110	200	910	17-35	45	HM WM SW	

Fig. no.	Type	Provenance	Fabric	Dec.	Surface treatment	Dia.	%	Man.	Comments
3.9.6	2833	(AB4)33 (AC6)14 (AD5)1 (FS3)6 (TG5)6	67 71 92			17-23	59	HM SW	
3.9.6	2891	(BD2)50	67			52	7	SW	
3.9.6	2993	(AB4)23 (AD5)167 (FR3)1 (FS3)13 (TG5)89,91	67 71 92 92C			24-50	57	HM SW	
3.9.6	3073	(AC5)77 (AD5)1,80,97,157 (FR3)2 (TG5)4	1 67 69 71 92		825IW RBRIE	17-30	97	HM WM SW	
3.9.6	+3074	(AD5)1,20,34,77,87,141 (AC5)37,49,57 (FO6)58 (FP6)135	67 71 92 94 110			17-45	231	HM WM SW	
3.9.6	3093	(AC5)73 (AD5)7 (FP6)9	71 110			20-25	30	HM WM	
3.9.6	3206	(AC5)39 (AD5)31,50,61 (FR4)2 (TG5)46	92 94 95		800E H820ER	10-15	298	WM	
3.9.6	3338	(AD5)136 (TG5)1	92			16	24	HM SW	
3.9.6	3364	(AD5)115	92C			21	12	SW	
3.9.6	3444	(FS3)6	92			25	5	HM	
3.9.6	3465	(FP6)24 (FO4)8 (FR3)0 (FR4)9	92 92C 105			27-60	34	HM	
3.9.6	3670	(TG5)68	-			-	-	HM	
3.9.6	3875	(AC5)116,153,172,178 (FO7)65 (FO4)8	92 110		R805EI 910 RBRIE	13-30	91	HM	
3.9.6	4084	(TG5)94	92		825EIBL	15	6	HM	
3.9.7	2105	(AB4)32 (AB5)66 (AC5)17 (AD5)260 (BC4)1 (BD2)71,81 (BD4)19 (BE1)51,67,68 (BF3)53 (CF5)1 (TG5)65	1 1C 71 89 92C			122	72	HM WM SW	
3.9.7	2126	(AC5)17	1			60	5	WM/ SW	
3.9.7	2234	(AB4)1 (AB6)13 (BE4)16	1 71 80		825EG	25-60	29	HM WM SW	CB
3.9.7	2433	(BE3)27	67	1031		30	7	HM	
3.9.7	2454	(BE3)18	25	1012		-	-	HM	
3.9.7	2472	(AB4)1 (BE1)158 (BE3)16	67 71 92	1002 1012/R		25-35	36	HM SW	
3.9.7	+3084	(AD5)1,84	67	1091	825EIW	28.5 x 17.5	100	HM	oval
3.9.7	4155	(FO6)53	92			-	-	HM	rim straight, no curve over 15cm
3.9.7	4417	(CE4)61 (CF4)21	67 110	200 1212		4+	4	HM	square in plan
3.9.7	4692	(FP6)128	105			22	14	HM	

Fig. no.	Type	Provenance	Fabric	Dec.	Surface treatment	Dia.	%	Man.	Comments
3.9.7	4809	(AD5)67	92	200 1112 1161		30-85	62	HM	
3.9.8	2914	(AB4)20	67C			37	12	SW	CB
3.9.8	3256	(AC5)28,34,37,39 (FS3)4	67		825EW 825EIW 822W	35-60	21	HM	CB
3.9.8	+3367	(AD5)154	67			-	-	HM	
3.9.8	3846	(AC5)129 (CF4)92	71 110			20-22	11	HM	
3.9.8	4639	(FQ4)119	92?			80 x -	-	HM	
3.9.9	311	(AC6)12	71			40	7	HM	
3.9.9	2288	(BE3)32,44,56 (FS3)2	71 92		825EGR	31-54	43	HM	
3.9.9	2301a	(BE3)56	92		825EB	28	11	HM	
3.9.9	2347	(BE1)6 (BE3)37 (CF4)113 (FO6)52	2 69 92 110	38g 850 x 2		13-33	33	HM	
3.9.9	2458	(AB4)20 (BE3)10	71 92	850	822R	28-35	23	HM	
3.9.9	2637	(AB4)11 (AB5)71	67		825EW	28-35	26	WM	
3.9.9	3050	(AB5)347	71			37	7	HM	
3.9.9	3789	(AC5)73 (CF4)104	71 94			22	14	HM	
3.9.9	4059	(TG5)46,87	71 92	702/R		50-60	7	HM	
3.9.10	2419	(BE3)1	67			-	-	HM	
3.9.10	2506	(AB6)1 (AC5)33 (JG2)1	67 92 106		820IO 825ECR RBRIE	20-42	14	WM	
3.9.10	2544	(AB4)1 (BE1)103	67	1002	820EW 820IGR/P	46	11	WM	
3.9.10	2646	(AB4)5 (BF1)33 (TG5)29,116	2 71 92C 110	1161		31-56	26	HM	
3.9.10	2720	(BE1)49	67	1004		54	3	WM/ SW?	
3.9.10	2785	(BD2)24,26,28,50 (TG5)65	1 92 94	1004		45-60	35	HM WM	
3.9.10	2793	(BD2)47	11	1004		60	10	HM	
3.9.10	4247	(TG5)84	-			45	-	-	
3.9.10	4533	(CE4)11	92	lug		40	11	HM	
3.9.11	2320	(AC5)128 (BD2)45 (BE1)73 (BF3)38 (FQ3)48 (FR3)19 (TG5)65,103 (AB4)23 (CF4)117 (FP6)109 (FQ3)40 (FS3)11 (TG5)29	71 92	lug string cut	820IW	18-50	46	HM	(FQ3) from brick
3.9.11	2967	(AB4)23	25 67 71		820IW 822W	31-60	34	HM	
3.9.11	2994	Area A (AC5)17 (CF3)2 (FP6)128 (TG5)1,2,7,73,94 (CF5)4 (TG5)1 (ZH5)85	71			20	13	HM	
3.9.11	3020	(AB4)/(AD6)(CF3)49	92 92C 71	702E		35-60	54	HM	
3.9.11	3137	(AC5)73 (FS3)11 (FP6)9 (FS3)11	67 71 92		825EIW	40-50	16	HM	
3.9.11	3431	(TG5)73	67 71			(21)-60	11	HM	
3.9.11	3432	(FO6)138	71		820IW	42-50	42	HM	CB
3.9.11	3434	(TG5)74	71	sub- rectangular	820W/P	40-50	8	HM	CB re-plastered
3.9.11	4056		71			?	-	HM	CB
3.9.11	4165		71			16	20	HM	IB??
3.9.11	4309		92C			12	7	HM	

Fig. no.	Type	Provenance	Fabric	Dec.	Surface treatment	Dia.	%	Man.	Comments
3.9.11	4395	(CF5)4	71			55	5	HM	
3.9.12	2134	(AB5)21 (BE4)11 (FS3)2	1 92		820IO	35-60	13	HM	
3.9.12	2134a	(AB4)6,23 (AC5)12 (AC6)86 (BC4)2 (BD2)24,32 (BD3)16,28 (BE1),22 (BE2)32,48 (BE3)1,27 (BF1)6,53,57 (FQ4)110	1 69 71	702E	820IP 820IW 820EW	32-60	182	HM SW CB	
3.9.12	2222	(AB4)14,22,23,28,31 (AC5)38,49 (AD5)28,34,97,149 (BC4)1 (BD2)26,28,49,96 (BE1)41 (BE4)15,16,37 (BF2)1,5,1,56 (FP6)143 (FQ4)76 (FR3)3 (FS3)1,2 (TG5)65,89,102,109	92 92C 71 71L	string cut R/B	820IW 825Egr. 840IW	(22)38-60	318	HM CB	
3.9.12	2489	(AB4)9,11 (AC5)12 (AD5)296 (BD2)32 (BD3)5 (BE1)13 (BE3)10 (BF1)53	1 12 92 71			11-21 40-50	98	HM WM	
3.9.12	2890	(BE3)27	71			56	-	HM	
3.9.12	4637	(AC5)130	92			53	7	HM	
3.9.13	2046	(BE1)10 (BE4)9	92			12-14	41	HM	
3.9.13	2688	(AB4)10 (AC5)38 (BD3)5 (BE1)100 (BF2)56 (TG5)73	71 92C	1082		19	8 items	HM	
3.9.13	+2717	(BE1)41	71	1062		-	-	HM	
3.9.13	2740	(BF1)6,61	71	4 finger holes	825EW	20	-	HM	
3.9.13	2741	(BD2)50,71 (BD3)28 (BE3)37,59 (BF1)6 (TG5)46	71 92	3 finger holes		-	-	HM	
3.9.13	2771	(BF1)75	71	2 finger holes		20	13	HM	
3.9.13	2863	(AB5)207 (BE2)159	71 92			19-22	35	HM WM	
3.9.13	3228	(AD5)47,102	92		825EBL	13	120	HM WM	
3.9.13	3765	(AC5)77	92			60	5	HM	
3.9.13	4733	(BE3)10,16	92C			-	-	HM	
3.9.13	+4734	(BE3)16	92			-	-	HM	
3.9.13	4735	(BE3)10	71			-	-	HM	

3.10. Beakers and offering dishes

Most vessels in this section are wheel-made. The small coarse wheel-made dishes are ubiquitous in funerary and ritual contexts from the New Kingdom (cf. e.g. Bonnet 2002, pl. 2) to the Meroitic period (RCK, *passim*), whereas the large beakers (3.10.1-3.10.2) are much rarer. At Kawa they were found in considerable quantities in Building A2 and most likely had a function connected with the shrine. Many were also found almost whole in the uppermost layer of the rubbish deposit to the north of Building A2. Where the rims only occur in other areas, without the distinctive chunky bases which are recognisable even when very fragmentary, they may have belonged to a different form, with a thinner-walled base. The beakers, as opposed to the dishes, may have been brought by individual ‘worshippers’ rather than being made nearby like the offering dishes, as they vary more in execution and surface finish and even fabric, i.e. they were made by several different potters. The red-slipped, slim beakers are on the other hand a typical component of the Napatan ceramic repertoire.

3.10.1 Round based, vertical-sided beakers

Mostly from Area A. Average capacity 1.8lt.

2571x: Bar. 11, 315-270 BC, MFA acc. no. 20.4009; Nu.61 (23, 397-362 BC) fig. 180, 18-2-369, red ware.

3014x: Nu.43 (24? 362-342 BC) fig. 183, 17-12-125.

3287x: Nu.77 (6, 664-653 BC) fig. 16, 18-2-20 (base missing).

3289x: Beg.W.859 (6-12, 664-538 BC) fig. A.11.

3.10.2 Various types of beakers, plain and red slipped

2337x: Nu.11 (19, 453-423 BC) fig. 151, 17-4-753, narrower diameter but also flat base.

2732x: Ku.53 (2, 751-716 BC) fig. 29.5, 19-3-1208 red ware, with flat base.

2810x: Mohamed Ahmed 1992, fig. 23 I D35b, mid 6th to early 5th centuries BC.

+4106x: Beg.N.28 (66, AD 246-266) fig. 122, 21-3-389 FHRW, but smaller.

4332x: Beg.W.109 (60-70, AD 167-317) fig. K13, 22-1-543; Beg.W.139 (50-55, AD 25-115) fig. E17, 22-2-277.

+4780x: Beg.N.6 (46, 26-20 BC) fig. 73, 21-3-322 FHRW, with a black section under the red.

3.10.3 Small beakers, tall narrow beakers and various beaker bases

2150x: Griffith 1923, 100, pl. XVIII.XIIIm, Napatan.

2536x: As 2150x.

2748x: Mohamed Ahmed 1992, fig. 23 I E4 early 7th to early 5th centuries BC.

2955x: Napatan.

2956x: Nu.1 (5, 690-664 BC) fig. 4, 17-2-1917; Nu.36 (5, 690-664 BC) fig. 10, 17-2-1855 (less persuasive as a parallel); Nu.3 (8, 643-623 BC) fig. 28, 16-12-237 red ware, narrower centre; Nu.6 (9, 623-593 BC) fig. 38, 16-11-32 red ware; Nu.28 (11? 568-553 BC) fig. 95, 17-3-631; Nu.10 (14, 533-513 BC) fig. 118, 17-4-723; Nu.4 (17, 478-458 BC) fig. 134, 17-2-1899; Nu.12 (21, 418-398 BC) fig. 163, 17-1-155.

3223x: Vila 1980, fig. 28.6, type II-1A, Napatan.

3246x: Williams 1990, fig. 20b, cemetery W2 near Qustul, grave W75, Napatan.

+3255x: Vila 1980, fig. 28.9, type II-1B, Napatan.

3403x: Ruffieux 2007, pl. 3.25 [12 B-20], Nile clay. Dokki Gel, Napatan. The parallel also fits 3255x, but here the slip has been applied vertically, like the parallel.

3987x: Mohamed Ahmed 1992, IE3, IE1, first half of 8th to end of 7th centuries BC.

3.10.4 Beaker bases and flat-based beakers

2023x: This form, of all the types presented on this page, with the finger marks near the base, could belong to an Egyptian-style so-called beer bottle, of New Kingdom date.

2573x: Nu.8 (10, 593-568 BC) fig. 69, 17-4-570, red ware.

3071x: Note the elaborate base trimming with a sharp tool.

3236x: Nu.23 (9, 623-593 BC) fig. 48, 17-3-521.

3.10.5 Flat-based cups

All apart from 4534x are wheel-made.

+2317x: Nu.43 (24? 362-342 BC) fig. 183, 17-12-28 red ware; Beg.N.2 (45, 43-26 BC) fig. 71, 21-2-726a; Beg.W.657 (3-6? 716-653 BC) fig. A22, 23-3-475a.

2574x: Nu.8 (10, 593-568 BC) fig. 69, 17-4-572.

+2586x: Nu.26 (12, 553-538 BC) fig. 111, 17-4-1156; Nu.5 (12, 553-538 BC) fig. 108, 18-3-774, RBW.

2927x: Worm, so not for one-off ceremonial use only? Nu.5 (12, 553-538 BC) fig. 108, 17-4-387.

2948x and similar forms: Laming Macadam 1955, II, pl. XXXII.10 [2056], Napatan.

3309x: Nu.27 (10, 593-568 BC) fig. 84, no number, red ware; Nu.26 (12, 553-538 BC) fig. 110, 18-2-660.

3314x: Nu.27 (10, 593-568 BC) fig. 84, foundation deposit. MFA database, same context, acc. no. 20.4416, dated to 623-568 BC.

+3810x: Nu.5 (12, 553-538 BC) fig. 104, 18-3-774; Beg.N.7 (33, 248-220 BC) fig. 36, 21-12-101a, as lid; Beg.N.8 (35, 203-186 BC) fig. 41, 21-12-93.

3.10.6 Flat-based dishes

Varying base diameters and carinated bowls. Various parallels in Nu.34 (23, 397-362 BC) fig. 174; Nu.13 (23, 397-362) fig. 171; Nu.32 (19? 453-423 BC) fig. 156; Beg.S.503 (29I, 297-284 BC) fig. 16, 22-1-716. See also Nowotnick 2018, figs 3 and 12. It could be argued that the variations except in the broadest characteristics are hardly date specific, given the rough and ready nature of the manufacturing process. It is interesting to note that in Building A2 fragments of 2107x and 2109x as well as a body sherd in the same ware and fabric were found with traces of red, yellow and blue paint pigment, as if they had been used to prepare or apply the paint (Plate 3.10.1). The same colours were used in the frescoes in Building A1.

2107x: Beg.S.2 (28, 315-297 BC) fig. 10, 21-2-477a; Nu.2 (16, 503-478 BC) fig. 128, 18-3-506; Nu.61 (23, 397-362 BC) fig. 180, 18-2-371.

2108x: Nu.50 (16? 503-478 BC) fig. 132, 17-2-97.

+2109x: Very common form, for example Nu.29 (17, 478-



Plate 3.10.1. Dishes found in Building A2, used to mix (or apply) pigments.
From left to right: (AD5)126, 2109x; (AD5)69, body sherd, (AD5)28, and 2107x (3.10.6).

458 BC) fig. 138, 17-4-1281, north-west foundation deposit.

2110x: Nu.47 (10, 593-568 BC) fig. 130, 18-1-161; Laming Macadam 1955, II, pl. XXXII.11a [2047], Napatan.

2575x: Nu.39 (11, 568-553 BC) fig. 99, 18-1-48.

2942x: Nu.44 (23, 397-362 BC) fig. 178, 17-4-32, FHRW; Boulet 2018, fig. 1.q, 25th Dynasty.

2949x: Nu.24 (10, 593-568 BC) fig. 78, 18-2-632; Nu.8 (10, 593-568 BC) fig. 69, 17-4-544; Nu.41 (8, 643-623 BC) fig. 31, 17-3-595.

2950x: Nu.2 (503-478 BC) fig. 128, 18-3-506, foundation deposit; according to the MFA website, 510-478 BC; Nu.4 (17, 478-458 BC), fig. 136, 17-4-327, south-west foundation deposit.

2951x: Nu.37 (25, 342-328 BC) fig. 190, 17-3-344; Nu.39 (11, 568-553 BC) fig. 99, 18-1-43, red ware; Laming Macadam 1955, II, pl. XXXII.11.b [2046], Napatan.

2960x: Boulet and Defermez 2014, fig. 31-1.A, Third Intermediate Period; but consider also Beg.W.126 (55-65? AD 93-246) fig. F6, 22-2-197b.

2961x: Vila 1980, fig. 28.2, type II-2, Napatan.

2964x: Nu.23 (9, 623-593 BC) fig. 48, 17-3-512, red ware; Laming Macadam 1955, II, pl. XXXII.9 [2148], Napatan; Mohamed Ahmed 1992, fig. 28 III B6a, mid 6th to late 5th centuries BC.

3015x: Nu.47 (16, 503-478 BC) fig. 130, 18-1-407, foundation deposit.

3055x: Nu.4 (17, 478-458 BC) fig. 135, 17-4-103.

+3088x: Nu.37 (25, 342-328 BC) fig. 190, 17-3-343, also distorted.

3214x: Ku.2 (24, 362-342 BC) fig. 9a, 18-3-820 (south-east foundation deposit).

3229x: Nu.15 (26, 328-308 BC) fig. 193, 20-4-10, foundation deposit.

3333x: Nu.43 (24? 362-342 BC) fig. 183, 17-12-27.

3.10.7 Round-based dishes

2839x: Ku.4 (5, 690-664 BC) fig. 11b, 19-2-597 red ware; Nu.8 (10, 593-568 BC) fig. 69, 17-4-569; Nu.10 (14, 533-513 BC) fig. 117, 17-1-363.

3135x: Beg.S.503 (29.I, 297-284 BC) fig. 16, 22-1-71a.

3802x: Nu.11 (19, 453-423 BC) fig. 150, 17-1-131, red ware.

4176x: Nu.26 (12, 553-538 BC) fig. 110, 18-3-760.

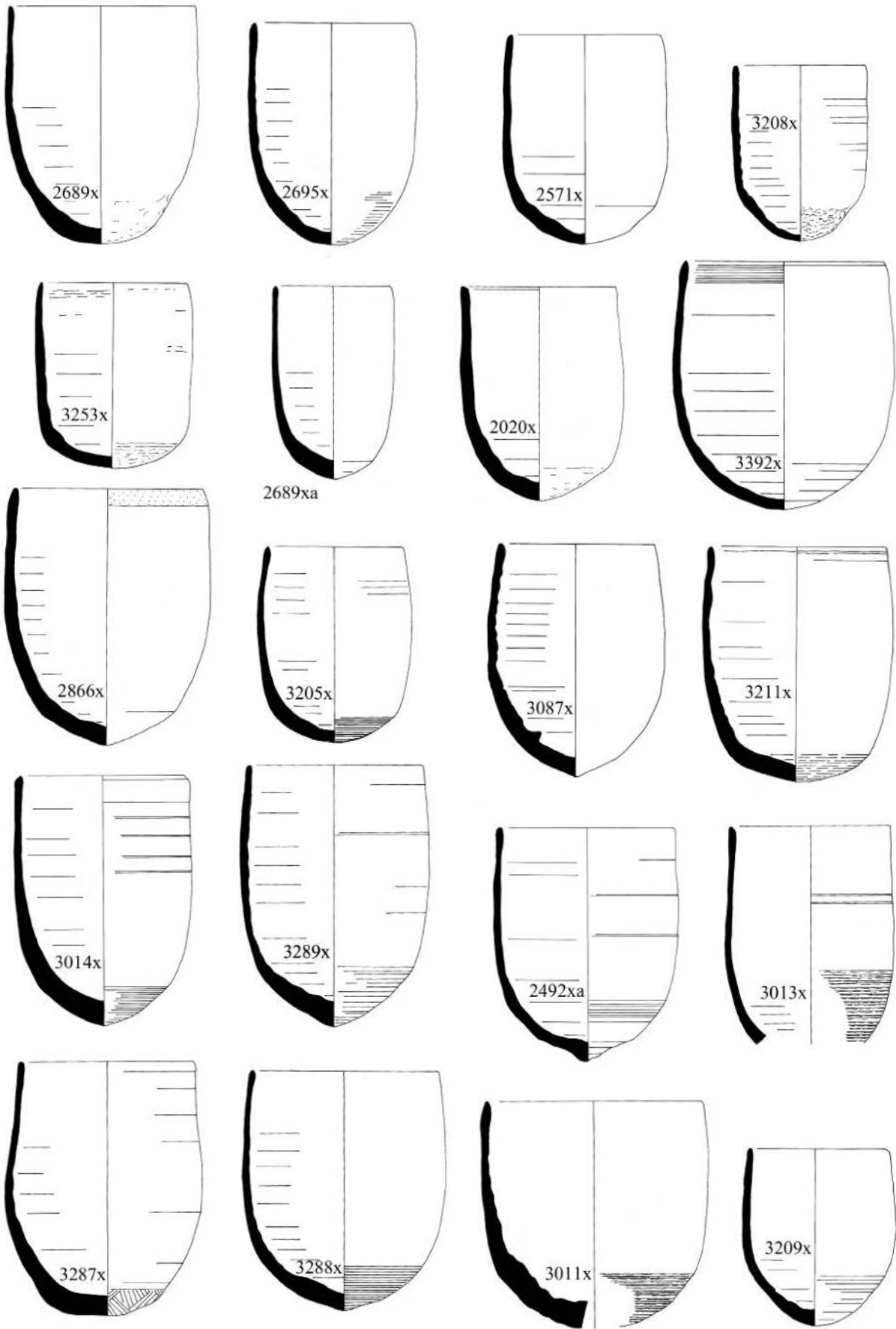

Figure 3.10.1. Beakers with rounded bases (scale 1:4).

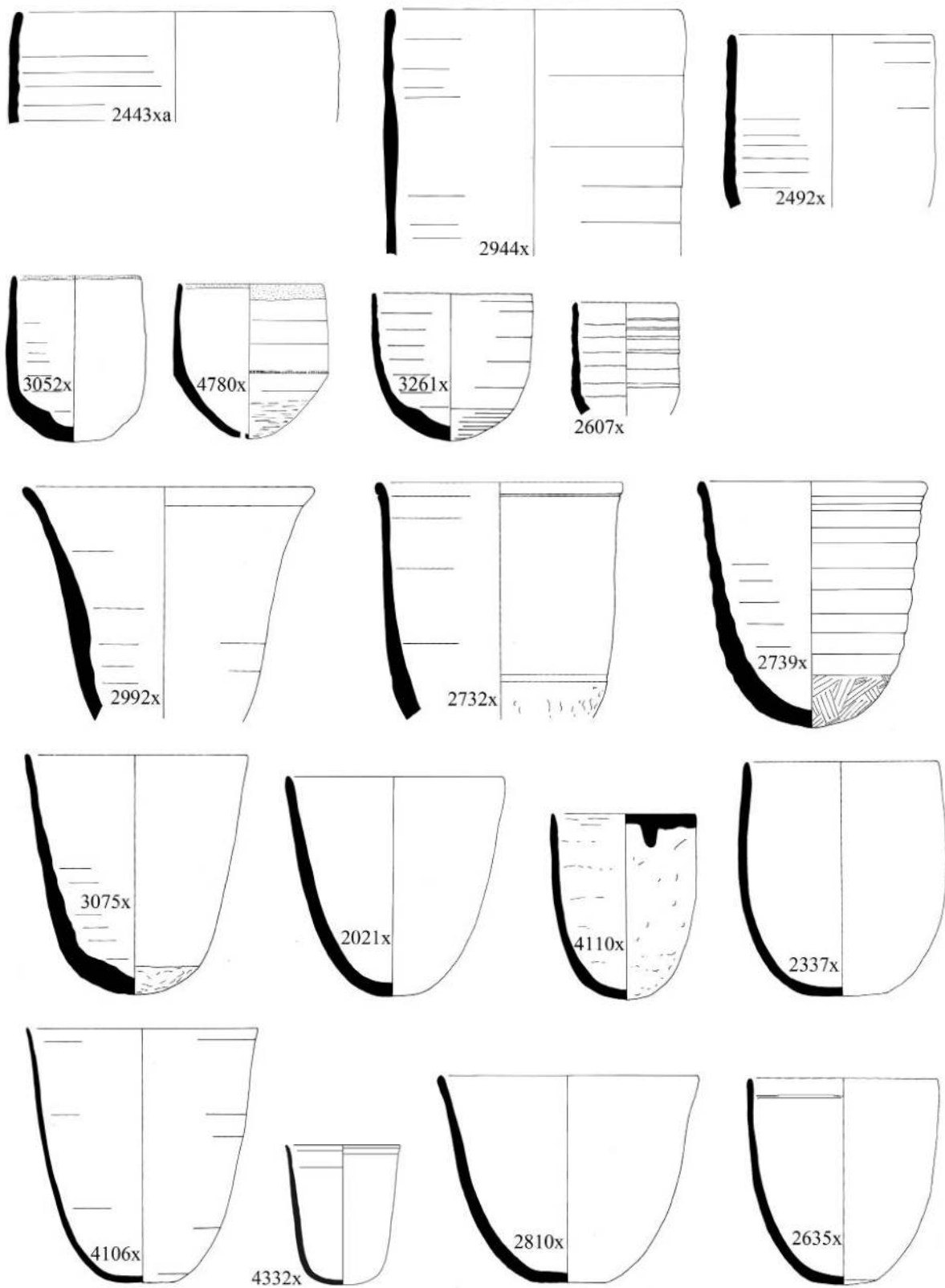

Figure 3.10.2. Various beakers, including ones with flat bases (scale 1:4).

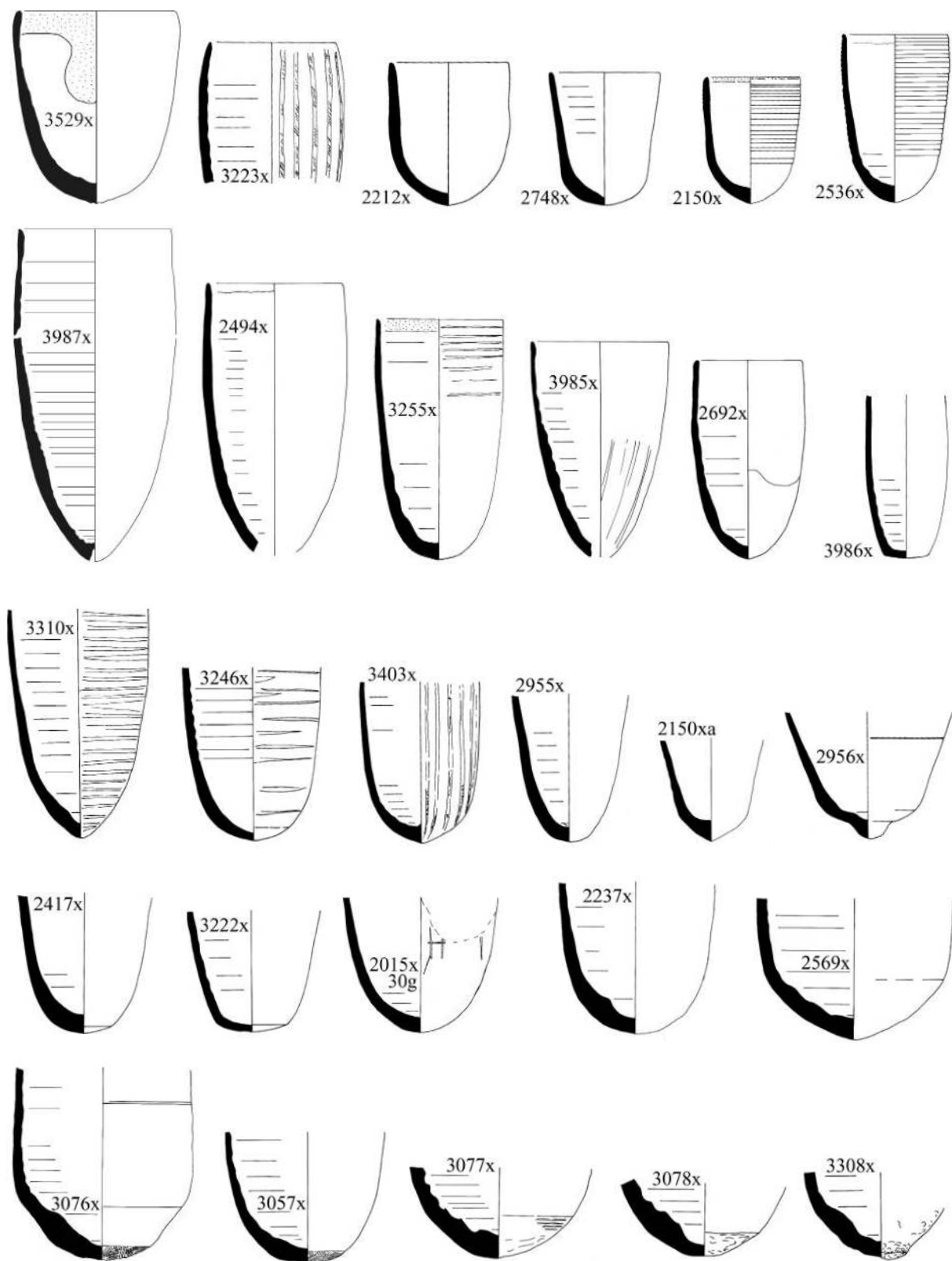

Figure 3.10.3. Small beakers, tall beakers and various beaker bases (scale 1:4).

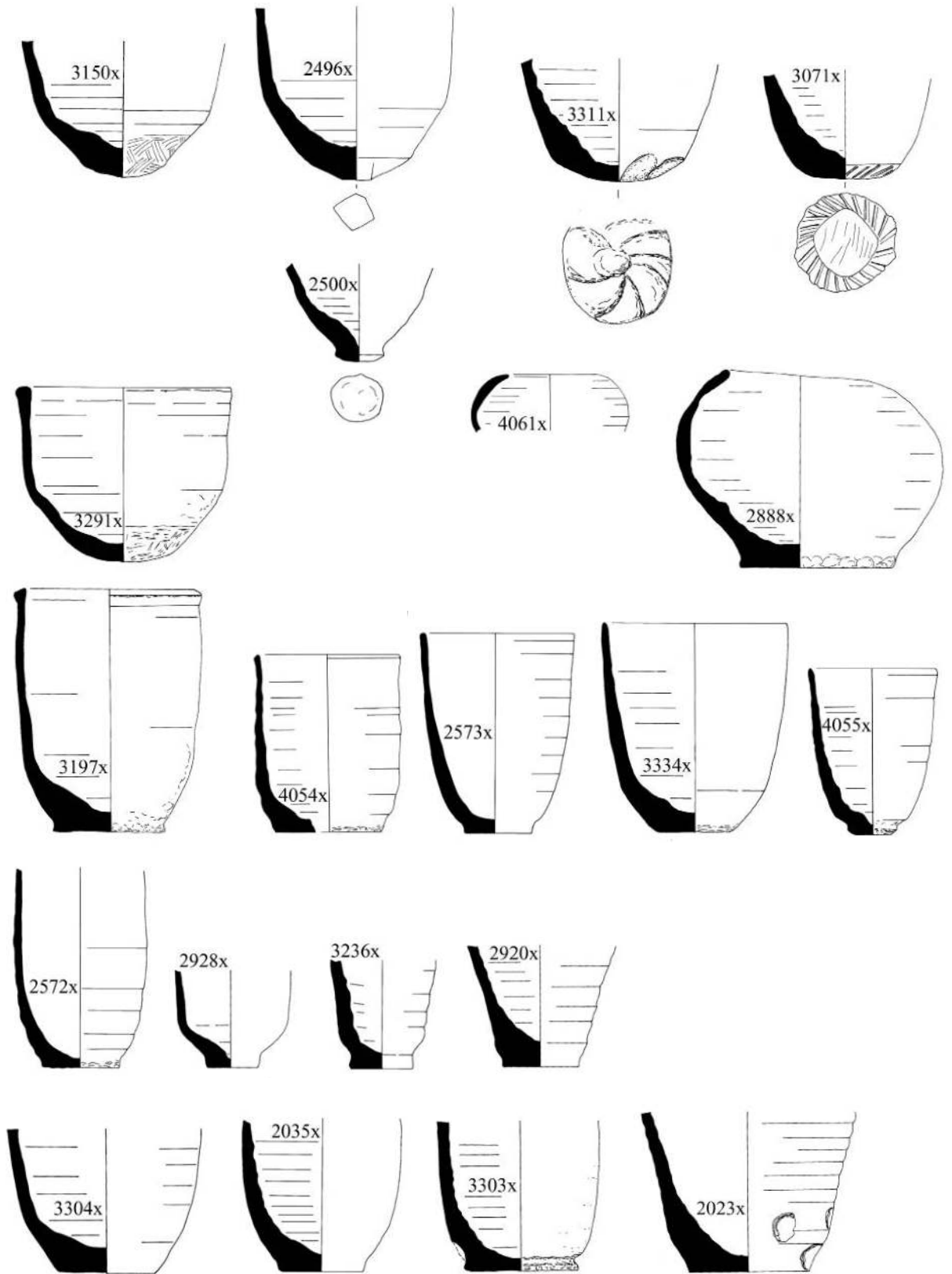

Figure 3.10.4. Rounded beaker bases and flat-based beakers (scale 1:4).



Figure 3.10.5. Flat-based cups (scale 1:4).

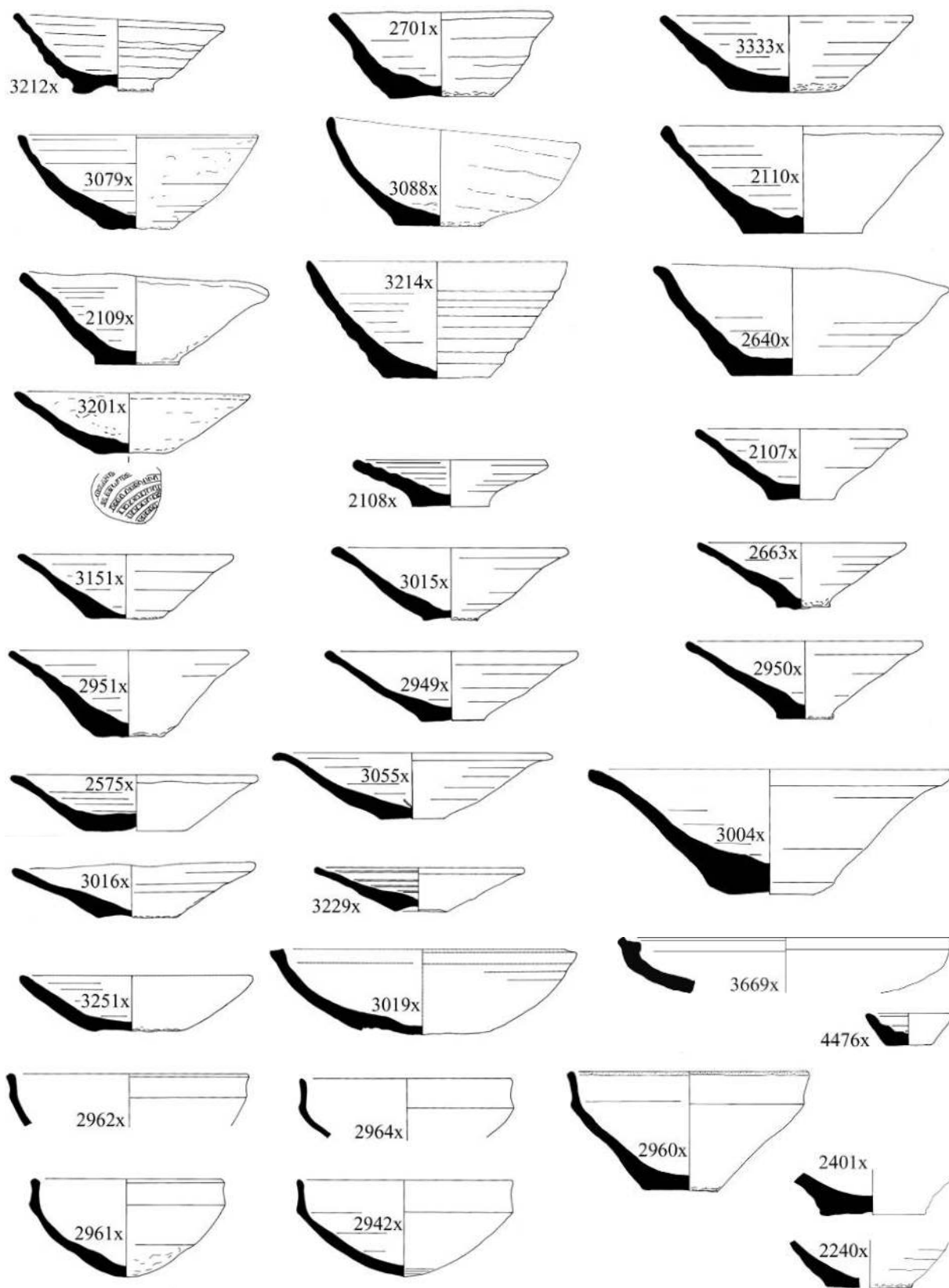

Figure 3.10.6. Flat-based dishes and carinated bowls (scale 1:4).

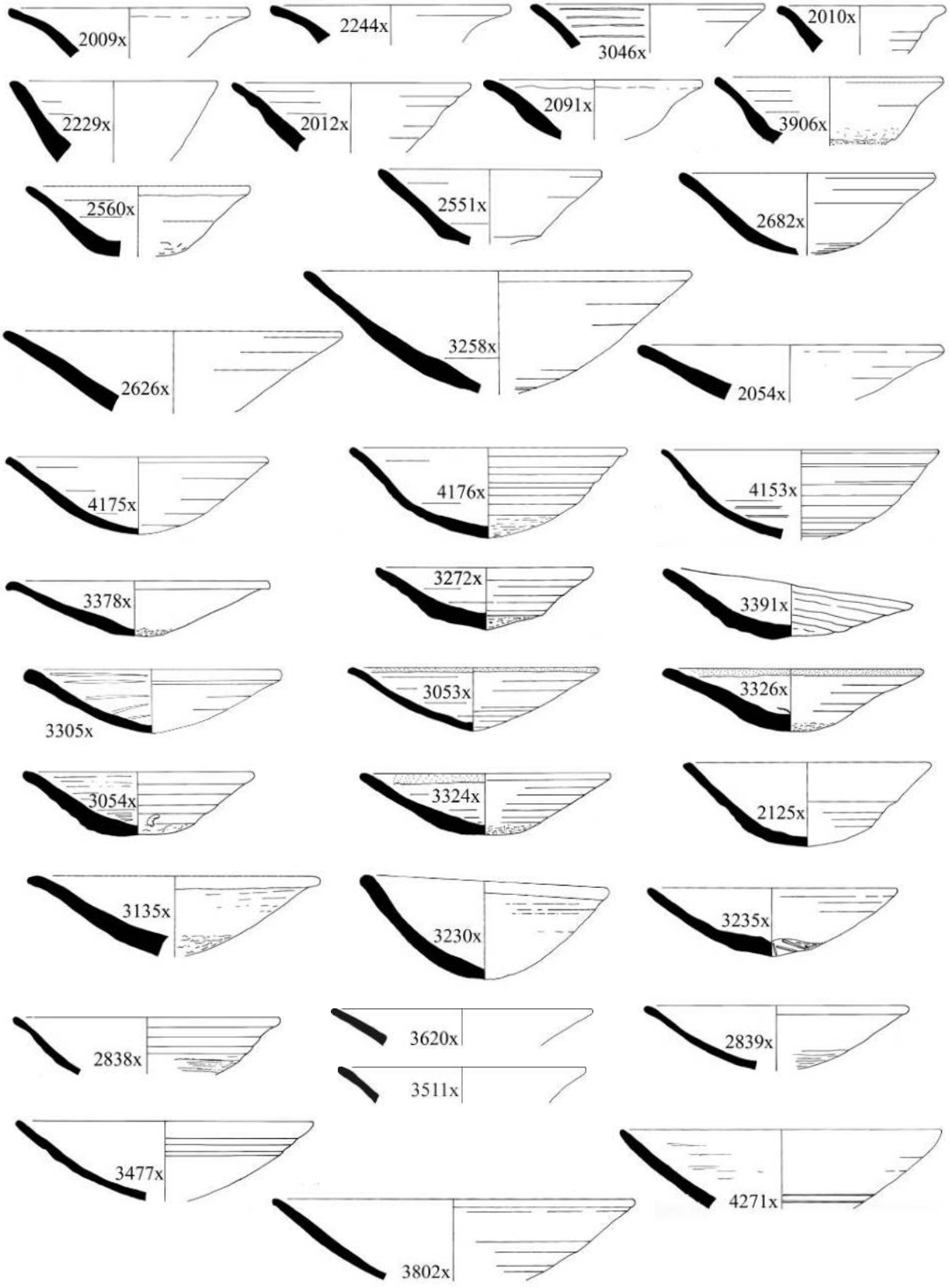
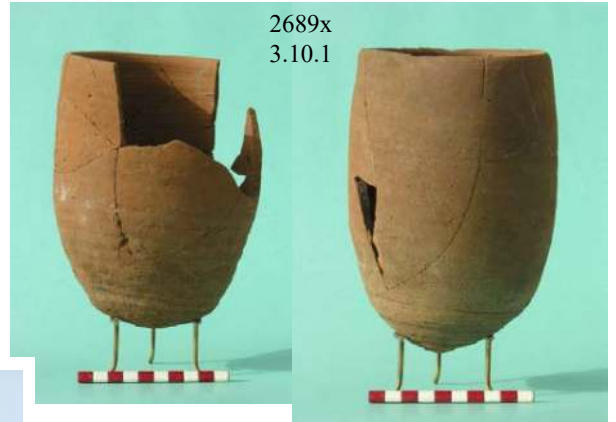

Figure 3.10.7. Round-based dishes (scale 1:4).

2689xa
3.10.1



*Plate 3.10.2. Beakers
and offering dishes.*



2689x
3.10.1

4780x
3.10.2



4106x
3.10.2



3019x
3.10.6



3255x
3.10.3



2692x
3.10.3



2494x
3.10.3



2888x
3.10.4



2317x
3.10.5



3810x 3.10.5



2586x
3.10.5



2584x
3.10.5



2109x 3.10.6



3088x
3.10.6



3326x
3.10.7



TABLE 3.10. BEAKERS AND OFFERING DISHES.

Fig. no.	Type	Provenience	Fabric	Dec.	Surface treatment	Dia.	%	Man.	Comments
3.10.1	2020	(AB4)23 (AB5)25,32,66,298 (AC5)17,23,24,28,36,38,59 (AD5)4,7,10,28 (BE4)9,22 (BF2)10,40 (BF3)8,15 (TG5)89 (ZH5)60 (AB5)45	61 67 69 71 75 92 69		822R RBRIE 825EIR	13-27 (45?) 14	309 B 995 78	HM WM WM	some bases knife trimmed oval
3.10.1	2492a								
3.10.1	2571	(AB4)10 (AB5)25,32,66,298 (AC5)17,23,24,28,36,38,59 (AD5)4,7,10,28,33,34,41,47,(ZH5)60	25 67 69 83 92 93 94 94F 97 98		V820ER 822R 825EW	10-15	1,506 B 400	HM (1) WM	1 B post-firing B mould-made HT 14,5,16,5,17,7, 19,2
3.10.1	+2689	(AB4)11,28,31,32 (AB5)32,231 (AC5)13,17,23,24,28,34,37,38,49,53,57 (AD5)1,4,7,12,20,22,28,32,34,41,45,47,49,55,56,57,60,62,66,67,69,71,73,80,117,126,128,132,134,160 (FQ3)58 (FQ4)7,33,48,49,80 (FR4)7 (HA2)36 gr. 31 (TG5)46,94	25 65 69 80 90 92 92F 94 94F		H820ER V820ER 820ER 825ER V825ER 825EIBR 825EIO 825EIR 825EW	10-17 (21)	6,467 B 2,825	WM	1 B post-firing hole B mould-made HT 16,17,5,18,5, 18,7
3.10.1	+2689a	(AC5)36,39 (AD5)48,93,99,102,141,184 (TG5)85	69 90 92 92F 94		H820ER V820ER 820EW	11-15	98 B 80	WM	
3.10.1	2695	(AB4)11,23,28,31 (AB5)231,233,248,292 (AC5)13,17,18,23,24,28,33,34,38,39,45,46,50,51 (AD5)1,7,20,21,22,25,28,33,34,41,47,51,54,56,59,61,67,72,77,84,87,88,93,97,99,101,102,105,107,112,113,115,116,118,119,123,124,133,136,137,139,155,161,162 (CF4)132 (FQ3)8,65 (FQ4)3,7,64,80 (FQ/R4)2 (FR3)0,19 (FR4)1,2,3	25 65 67 69 80 90 92 92F 93 94 94F 97		820EP 820ER V820ER V820EBR 825ER V825ER 825IBL 825IR 825EIGR 825EW RBRIE	9-20	7,546 B 2,200	WM	
3.10.1	2866	(AB4)20 (AB5)263 (AC5)17 (AD5)1,7,34,47,148,153,230 (BD3)32 (FR3)13 (FR4)3	69 92 94		V820ER 822CR 825ER	11-18 (22-24)	522 B 20	WM	HT 16.5 -19.8
3.10.1	3011	(AB5)250 (AD5)7,69	92			16-17	127	WM	B mould-made
3.10.1	3013	(AC5)17,28 (AD5)22,41,56,198 (FO6)46 (FP6)156	69 92 92F 94		R805E 820ER 825ER	12-14	108	WM	
3.10.1	3014	(AC5)17 (AD5)4,25,34,47 137 (FR4)2 (FT3)49 (TG5)5/4,46	67 92 93 94		V820ER 825EW	13-17	419 B 250	WM	PRO HT 17
3.10.1	3087	(AD5)4 (FQ3)41	90 92		825ER	12-18	108		
3.10.1	3205	(AC5)37,45 (AD5)28,41,61,132,155	25 80 90 92 94F			9-15	368	WM	
3.10.1	3208	(AD5)41,69,136	92			9,6-14	86	WM	
3.10.1	3209	(AC5)39 (AD5)31,50,61 (FR3)13 (FR4)2 (TG5)46	67 92 94 95		800E H820ER V825ER	10-15	224	WM	
3.10.1	3211	(AD5)34,160	69 94			13	32	WM	
3.10.1	3253	(AC5)34 (AD5)119,230	92			11-21	73	WM	
3.10.1	3287	(AC5)45 (AD5)21,34,51 (TG5)91	92 92F		825EBR	12-19	90	WM	

Fig. no.	Type	Provenance	Fabric	Dec.	Surface treatment	Dia.	%	Man.	Comments
3.10.1	3288	(AB5)25 (AC5)34,50 (AD5)7,10,12,47,93,246 (AD6)13 (FO6)58 (FQ4)2,6	69 81 92 95		H805EI V820ER 820ER 825EBL 825EIO	12-19	704	WM	HT 18
3.10.1	3289	(AD5)30,31,47,241 (FR4)2 (TG5)65	67 69 92 92F		RBRE	12-26	459	HM WM	
3.10.1	3392	(AC5)45 (AD5)207	69 93F			15	56	WM	
3.10.2	2021	(BE2)10,110 (BE3)9,17,27,33,55,63,70,78,118 (BE4)8,9,12 (BF3)8,9,17,27,50 (CE4)23,37,42 (CE5)1 (CF3)22 (CF4)1,81,155 (TG5)1,5/4,7,102-105	1 2 67 69 80 83 92 94 94F 95 110	1204	820ER 820IB 822R 832W	14-31	264 B 155	HM WM	oil-soaked
3.10.2	2337	(AB4)7,20,23 (AB5)25,59,66,71 (AB6)1 (AC4)1 (AD5)20 (BD2)28,29 (BE1)7,9 (BE2)21,26,56,110,158 (BE3)18,27 (CE4)95 (FR3)1 (FT3)44 (ZH5)37	25 65 67 69 80 92 94		V820ER H820IR 820ER 820EW 822R H822R 825IR 910 RBRIE	11-24	551 B 100	HM WM	H 17
3.10.2	2443a	(AB5)35,89 (AC5)8 (AD5)192 (BE1)8 (BF1)28	25 67 79 80 92			14-26	32	WM	(BF1) deformed
3.10.2	2492	(AB4)7 (AB5)1,32,41B,89 (AC5)8 (AC6)16 (BD2)49,99,100 (BD4)17 (BE1)1 (BE2)66,87 (HA2)95 gr. 94	2 69F 92 93 94		820ER 822R 825TY 825ER	11-22	225 B 100	HM WM	
3.10.2	2607	(AB4)15 (AB5)80,234,248 (TG5)6	69 92		800E	7-14	113	WM	
3.10.2	2635	(AB5)65,245,277 (AC5)17,34,38,49 (BD2)26 (FR3)2 (FQ/R4)2 (HA2)60 gr. 58	69 71 92 94 95		820ER 820EW 822CR	11-26	291	HM WM SW	
3.10.2	2732	(BE2)160 (BF1)73	69 94		820E	12-17	43	WM	
3.10.2	2739	(AD5)28 (BC3)2 (BF1)6	67 92		822R	16-21	47	WM	
3.10.2	2810	(BD3)8	94		V822R	18	18	HM	oil-soaked
3.10.2	2944	(AB4)23	67			21	30	WM	
3.10.2	2992	(AB4)23 (AB5)302 (AD5)1,112 (CE4)1 (FS3)1	92 94		822R	20-30	54	HM WM	
3.10.2	3052	(AD5)7,25 (FR3)2	92			14	16	WM	
3.10.2	3075	(AD5)1,28 (TG5)65	92		V820ER	12-16	57	HM WM	
3.10.2	3261	(AC5)51 (AD5)28 (FP7)17	92 94			15	21	WM	
3.10.2	3985	(TG5)73-87	-			9.5	-	WM	
3.10.2	3987	(TG5)87-91	-			11	-	WM	
3.10.2	+4106	(FO6)19,71,89,92	92F		825EBR	16	81	WM	
3.10.2	4110	(FO6)90	58		805E/800E 810I	10.5	70	HM	
3.10.2	4332	(JH3)39 gr. 39	139			8	100	WM	
3.10.2	+4780	(GD3)12 gr. 11; 83B gr. 38	92		RBRIE	10	112	WM	post-firing hole B

Fig. no.	Type	Provenance	Fabric	Dec.	Surface treatment	Dia.	%	Man.	Comments
3.10.3	2015	(AB5)14,25,32,65 (AB6)7 (AC5)23,24,133 (AC6) 14 (AD5)168 (BC2)4 (BD2)70,81 (BD3)9 (BE1)9,18 (BE2)48,53,67,71,103,116,153 (BE3)1,16,78 (BE4)9, 20,29 (BF2)1,31 (BF3)8,9,15,30,40 (CF3)1 (FP7)15	13 61 65 66 67 69 76 80 81 83 90 92 94 95	30g	820ER 825ER	-	3,505	WM	some mould-made
3.10.3	2150	(BD2)71,100 (BE2)48 (BE3)1 (BE4)29 (BF3)8,50	16 26 67 69 77 88		820EER 825EER 825ER RIBBED	6.5-10	65	WM	
3.10.3	2150a	(BF2)37	56		820IR	-	-	WM	very abraded
3.10.3	2212	(AB4)23 (AB5)72,252 (BE2)66,110 (BF3)59 (TG5)7	61 69 92 94		820ER 822R 825ER 910 RBRI	8.5-19	112	HM WM	
3.10.3	2237	(AB4)10,11,23 (AB5)20,25,27 32,215 (AB6)7 (AC5)13,23 (AC6)1,8 (AD5)20,22,49,55,56,87,102,197 (BD2)47,96 (BD3)1,8 (BE1)8,18,44,87 (BE2)12,48,73,103,119 (BF1)35,52 (CF4)1,(FP6)9 (FQ/R4)2	25 65 67 69 76 80 92 92F 93 94		810E 820E,CR 820ER V820ER 822R 825ER 825EW	-	3,895	WM	
3.10.3	2417	(BE2)117 (TG5)5/4	69 92			3.8	140	WM	
3.10.3	+2494	(AB4)23 (AB5)1,32 (BE2)48 (CF4)21 (FQ4)21 (FQ/R4)2 (TG5)73,75,86-99,87,102	69 92 94 102		800E 820ER 822R 825IR	8-14	140	WM	
3.10.3	2536	(BE1)73 (BE2)103	82 88		820EW	7.5-11	18	WM	
3.10.3	2569	(AB4)6,7,10,11,20,22,23,28 (AB5)25,32,40,43,62,63,66,80,89,233,328 (AC5)13,18,21,23,24 (AC6)20 (AD5)1,56,149 (BD2)28,45 (BE3)146 (CE4)11,98 (FT3)2	25 65 67 69 80 89 92 94 94F 97		800E 820ER 820EW 825IBL 825EER 825EW 825EIW	10.5 - 15.5	10,230	WM	B mould-made lamp use - reuse
3.10.3	+2692	(AB4)11,22,23,28 (AB5)239 (AC5)12 (AD5)1 (BC3)3 (BD2)82 (BF1)6 (BF2)56 (CF4)21,96 (TG5)73,89,95,102	65 67 69 80 83 92 94 110		800E 820EO H820ER 820ER 820IR 825IW RBR	6.5-15	314 B 150	WM	
3.10.3	2748	(BF1)47 (TG5)4	94		820ER 822R	8-16	54	HM WM	
3.10.3	2955	(AB4)23 (CF4)101 (HA2)161 gr. 206	69 92 94		820ER	2.3	320	WM	
3.10.3	2956	(AB4)23	93			-	100	WM	
3.10.3	3057	(AC5)23 (AD5)33	92			5	180	WM	
3.10.3	3076	(AC5)23 (AD5)1,20 (CF4)21	92			11-13	479	WM	
3.10.3	3077	(AC5)23,28,33,34,37,38,39,46,57 (AD5)1,4,7,12,20,28,30,34,41,45,54,56,60,61,67,69,80,87,97,102,107,112,113,115,123,126,127,134,137 (FQ3)41 (FQ4)7,8,21,33,66 (FR3)10,22 (FR4)1,2,3,6,10 (TG5)29-105,117	25 65 69 80 89 92 92F 93 94 94F		820ER 820EW 825ER 825IR 825EW		19,848	WM	
3.10.3	3078	(AD5)1,7,20,28,34,41,45,47,54,56,59,69,80,84,87,93,124 (FR4)1 (TG5)1,76	11 89 90 92 92C 92F 93 94		820ER 820EW		9,985	WM	
3.10.3	3222	(AB4)10 (AD5)34,141 (TG5)44	92 94		820ER V820ER 820EW	4-7	405	WM	(AD5)34 reuse?
3.10.3	3223	(AD5)34 (CE4)85 (FP6)74 (TG5)74,77	92 94 110		820ER 822R 825IP	7-13 (28)	55	HM WM	

Fig. no.	Type	Provenance	Fabric	Dec.	Surface treatment	Dia.	%	Man.	Comments
3.10.3	3246	(AC5)28,34 (FP7)17 (HA,2)29 (TG5)29	69 92 94		H,V820ER 820ECR	-	175	WM	
3.10.3	+3255	(AC5)34,38,45 (AD5)28 (FO4)21 (FR4)2 (GD3)1,44 gr. 41,104 gr. 98 (TG5)1,7,65,91,109	69 92 94 94F	76g	820ER H820ER V820ER H822R	7-12	394	HM WM	
3.10.3	3308	(AC5)55 (CF3)22	92 94L		820ER	-	200	WM	1 deformed
3.10.3	3310	(AD5)60 (TG5)44	65 94		820ER V820ER	-	135	WM	
3.10.3	3403	(AC5)45 78 (CF4)73 (TG5)65	69 92		820ER V820ER 825ER	-	230	WM	
3.10.3	3529	(HA2)227 gr. 207	48		825ER	8.5	30	WM	
3.10.3	3986	(AB4)10 (TG5)73	-			3.2	-	WM	
3.10.4	2023	(AB4)10,23 (AB5)207,233 (BE3)57 (BF3)11 (FZ2)1 (TG5)74	25 67 69 92	702E string cut		6-11	440	WM	
3.10.4	2035	(AB4)7,10,23 (AB5)1,63 (AC5)1,173 (AD5)1,139 (BE1)18 (BE2)14 (BF1)53 (BF2)39 (TG5)6,29-105,112	1 25 67 69 92 93 94	702E string cut		5-8	1566	WM	
3.10.4	2496	(AB4)10,11 (AB5)1,35 (AD5)4 (BD3)16 (BF1)57 (AC5)8	25 67 92 93 94			-	936	WM	
3.10.4	2500	(AC5)8	92			3.5	100	WM	
3.10.4	2572	(AB4)7,23,28,31 (AB5)25,65 (AC5)24 (AC6)5 (AD5)1,28 (BF1)57 (TG5)29-105,44	67 69 92	702E string cut		4.5-6.5	1,567	WM	(AB4)23 hole in B
3.10.4	2573	(AB4)15 (AB5)25 (AD5)7,21 (CF4)30 (TG5)73,74,86,87,91,94	22 25 69 92 92C 94			9-13	378 B 1,065	HM WM	1 waster?
3.10.4	+2888	(AC6)38	67	702E string cut		11	100	WM	whole
3.10.4	2920	(AB4)22 (AD5)34 (TG5)44	69 92 94	702E string cut		5.5-8	216	WM	
3.10.4	2928	(AB4)23,31	92			3.5-5	69	WM	
3.10.4	3071	(AD5)1	92			7.5	60	WM	B trim
3.10.4	3150	(HA2)120 gr. 119	92			-	100	WM	tool marks B
3.10.4	3197	(AD5)20,113,127,133 (TG5)86-99	17 92		825EW	9-15	64	WM	
3.10.4	3236	(AD5)67	92			5	100	WM	
3.10.4	3291	(AD5)20,28	92			14-15	100	WM	
3.10.4	3303	(AD5)7 (JF2)29/24 (TG5)96	92 105			5-8	165	WM	
3.10.4	3304	(AD5)20	92			7	55	WM	
3.10.4	3311	(AD5)66	92			-	200	WM	
3.10.4	3334	(AD5)124	92			13	30	WM	
3.10.4	4054	(TG5)1,4,44,73,102-105	92 94 94L			6-15	213	WM	1 deformed
3.10.4	4055	(TG5)44,87	92 94			10-13	51	WM	
3.10.4	4060	(BF2)31 (TG5)4,73	67 80 94			18-30	45	WM	
3.10.4	4061	(TG5)73	94			6	70	WM	

Fig. no.	Type	Provenance	Fabric	Dec.	Surface treatment	Dia.	%	Man.	Comments
3.10.5	2016	(AB4)6,7,10,11,23,27,28,31,33 (AB5)40,68,80,207 (AC5)12,55,57,68,173 (AC6)4 (AD5)28 (BD2)71,81,101 (BD3)28 (BE1)9,41 (BE2)48 (BE3)16,57,78 (BE4)42 (BF1)6,16,57 (BF2)1,31 (BF3)50 (FR3)22 (TG5)4,7,3,102	1 2 8 9 25 65 67 69 80 92 94	702E string cut		(2.5)3.8- 3.10.5	3,674	WM	
3.10.5	2308	(AB4)1,6,7, 10,11,15,22,23,28,33 (AB5)1,20,32,40,58,59,66,68,80, 91,94 (AC5)13 (AD6)5 (BD2)71 (BE1)6 (BE2)68 (BE3)16 (BF3)38 (TG5)1,4,7,7,85 (ZH5)45	1 65 67 69 71 92	string cut	825EGR 825IW 825EIW	3.5-6 (15)	2,080	WM	1 pre-firing hole B
3.10.5	+2317	(AB4)10,15,23,28 (AB5)3,40,50,66,68,86,89,207,215 (AB6)1 (AC5)12,13 (AC6)12,30,34 (AD5)20,112,214 (BC4)1 (BD2)28 (BE2)57,67 (BE3)10,32 (BF3)38 (HA2)116 gr. 160	25 67 69 76 80 92 94	string cut	825EBL	11-25 3.6-6	1,004 B 560		
3.10.5	2470	(AB4)10,11 (AB5)80 (BE3)10 (CF4)1 (TG5)4,112	67 92 94	string cut	820EW	3.5-5.5	475	WM	
3.10.5	2574	(AB4)6,7,20,23,28,31,33 (AB5)25,37,38,42,59,63,80,89,207,239,279,29 2 (AB6)27 (AD5)198 (BD3)33	65 67 69 92 94	string cut	825I	12-18 4-6	881 B 696	WM	
3.10.5	2582	(AB4)11,23 (AB5)14	92			13 B 6	55 B 100	WM	
3.10.5	+2584	(AB4)1,4,6,10,11,23 (AB5)40,42,45,48,58,61,63,67,68,86,89,92,207,211, 218 (AC5)68 (AC6)20 (BF1)16 (CE4)37 (FT3)22 (TG5)87	1 65 67 69 76 92	string cut	822R 825EIR 825IW	11-20 (28)	594 B 504	WM	
3.10.5	2585	(AB4)6,31 (AB5)68,80,86,207,211 (AB6)27 (AD5)1,80 (BD2)38	2 69 92	string cut		10.5-16	266 B 121	WM	
3.10.5	+2586	(AB4)10,23,31,33 (AB5)58,68,207 (AD5)73,112 (HA2)60 gr. 58	67 80 92 94	string cut	RBRI	13-15	282 B 425	WM	
3.10.5	2598	(AB4)10,11,20,22,23,25,31,33 (AB5)43,58,80,89,207,211,239 (AC5)13 (AC6)20 (AD5)41,139,198 (FT3)6,92 (TG5)94	2 65 69 80 92	string cut	825EIW 931E/R	12-18 (24) 3.3-5	985 B 1,725	WM	
3.10.5	2616	(AB4)22,23,27,29,32,33 (AB5)348 (AC5)68 (TG5)73	69 92			12-17	676 B 295	WM	
3.10.5	2629	(AB4)7,11,23 (AB5)218 (BD2)45 (CE4)40 (FR4)7 (TG5)0	65 69 92 94 110	string cut		11-16	118 B 200	HM WM	
3.10.5	2683	(AB4)10,20,23,33 (AB5)207 (AD5)102	69 83 92 94		825EIW	13-16	132 B 155	WM	
3.10.5	2686	(AB4)10,20,23,33 (AB5)207 (AD5)67 (FQ/R)42	65 69 80 83 92 94		825EIW	12-18	181 B 200	WM	
3.10.5	2687	(BC3)2 (AB4)10	92 94	string cut		14-15	162	WM	1 deformed B hole post-firing
3.10.5	2700	(AB4)11,23,28,32 (TG5)112	92 94	string cut		5-7	1,205	WM	1 deformed
3.10.5	2797	(AB5)59 (BD2)28 (TG5)87	13 92		822W	14-25	15	HM WM	
3.10.5	2800	(AB4)23,33 (BD2)71,100	92		825EW RBRI	11-15	57	WM	
3.10.5	2858	(BD2)88	92		822R	12	11	WM	
3.10.5	2913	(AB4)20	65	702E		11.6	45	WM	

Fig. no.	Type	Provenance	Fabric	Dec.	Surface treatment	Dia.	%	Man.	Comments
3.10.5	2927	(AB4)23,28 (FQ4)75	92 94	702E	825EIW	13-14	158	HM	
3.10.5	2929	(AB4)23,31 (AD5)102 (TG5)44	65 69 92	string cut		12-17	498	WM	
3.10.5	2947	(AB4)23 (AC6)72	25 69 92			13-14	52 B 490	HM WM	
3.10.5	2948	(AB4)23 (AC5)73 (FQ/R4)2 (TG5)91	69 92		822CR	11-16	64 B 200	WM	
3.10.5	2986	(AB4)23 (AC5)45 (TG5)74	92		WBRIE	10-16	70	WM	
3.10.5	3024	(Z15)1	-			7	-	-	
3.10.5	3043	(AB5)273	92			14	12	WM	
3.10.5	3309	(AD5)56	92			18	7	WM	
3.10.5	3314	(AD5)80	92			16	70	WM	
3.10.5	+3810	(AC5)99 (TG5)100,92	92			10.7-12	105 B 30	WM	(AC5) street complete
3.10.5	3911	(FQ4)59	110			13	5	HM	
3.10.5	3943	(CE4)85 (FQ4)78	69 110		820EP 820ICR RBR TOP	10-14	10	HM WM	
3.10.5	3946	(TG5)44	-			13	-	WM	
3.10.5	4534	(CF4)154	92C	702E		12	100	HM	oil soaked
3.10.6	2107	98/1/4,51 (AB4)1,4,5,6,7,9,10,11,14,15,22,23,31,32,33 (AB5)1,3,20,25,27,29,32,35,40,58,59,63,64,65,66,68,70,80,86,91,94,207,208,211,220,223,225,229,322 (AB6)1,12 (AC5)8,12,13,17,18,23,24,33,36,39,45,46,50,51,57,68,93 (AC6)1,6,8,34 (AD5)0,1,4,7,10,20,21,22,25,28,30,31,32,34,36,37,41,45,47,48,54,55,56,59,61,62,66,67,71,72,73,77,80,82,84,87,88,93,97,99,102,107,104,112,113,115,116,118,119,123,127,128,131,133,134,135,136,148,153,161,180,203,207,217,227,248,273 (AD6)5 (BD2)47 (BE2)38,48,53 (BE3)55 (BF3)8,9 (CE5)6 (CF4)51 (FO6)37,47 (FO7)1 (FP6)5,34,138 (FP7)72 (FQ3)43 (FQ4)2,7,9,48,70,80,115 (FR3)0,2,13,14,22 (FS3)11 (JG2)1 (TG5)1,4,73,74,91,94,109,113,122 (ZH5)15	25 40 65 67 69 83 92 92F 94 94F 94L 95	1140 string cut	H820IR 825EO RBR1	(7)12-21 (24)	13,104 B 1,140	WM	some deformed B often cracked
3.10.6	2108	(AB4)11,23 (AB5)207,248,(AB6)1 (AC5)17,23	92	string cut		13.5-18	257 B 100	WM	
3.10.6	+2109	(AB4)7,11,15,20,22,23,27,28,31 (AB5)1,38,40,43,45,52,59,67,68,80,86,89,91,94,217,230,231,232,233,239,245,252,279,288,292,328 (AB6)27 (AC5)13,17,23,24,34,37,38,49 (AD5)1,2,7,20,28,34,41,47,48,56,61,69,97,117,126,132,134 (AD6)10 (FQ3)8,11,42,65 (FQ4)2,6,7,8,27,33,62,63,64 (FR4)1,2,3,10 (TG5)102-105	1 25 25L 65 69 80 92 92F 94	mark of pot above string cut	825IR	11-21	13,647 B 2,047	WM	
3.10.6	2110	(AB4)5,15,23 (AB5)1,317 (AB6)25 (AC5)8,12,17,24 (AC6)12 (AD5)1,4,20,22,28,31,45,56,67,73,115 (BE3)63 (TG5)35	29 92 94	mark of pot above string cut	825EIW	13-24	613 B 200	WM	

Fig. no.	Type	Provenance	Fabric	Dec.	Surface treatment	Dia.	%	Man.	Comments
3.10.6	2240	(AB4)1,6,7,10,11,15,22,23,27,28,31,32,33 (AB5)1,20,25,32,43,52,58,59,63,65,66,68,80,86,89,207,211,220,229,233,252,277 (AB6)1,3,12 (AC5)13,17,23,28,33,34,49,55 (AC6)8,17 (AD5)1,7,20,21,22,25,28,30,31,33,34,41,45,54,56,59,60,61,67,69,73,77,80,84,87,93,97,99,102,112,113,116,117,126,127,132,133,134,136,168 (BC3)2 (BC4)1 (BD2)26,71,101 (BD3)5 (BE1)6,13,61,67,73 (BE3)16,44 (BE4)9 (BF1)57 (CE4)11 (FQ3)40,61 (FQ4)5,7,35 (FQ/R4)2 (FR3)2,13 (FR4)1,2,3 (HA2)12 - (TG5)73,77,87,91	1 13C 25L 29 65 67 69 70 71 76 80 83 92 92C 94 94C	string cut mark of pot above	820ER 820IR 822W 825I	4.5-3.10.5 (11)	22,010	WM	
3.10.6	2401	(AB4)4,20,23 (AB5)32,207,231 (AC5)13 (AD5)34 (FN6)6	67 92 92F 94	string cut		4-9	1,009	WM	
3.10.6	2575	(AB5)25 (AC5)23 (AD5)31,113 (CF4)20,88	92 110		825IR	16-22	96 B 285	WM	
3.10.6	2640	(AB4)6,15,31	69 92	string cut		20-24	112	WM	
3.10.6	2663	(AB4)7,11,22,23,27 (AB5)239 (AC5)13,17 (AC6)20 (AD5)167 (CF4)113	92	string cut	825EBR RBRI	15-17	145 B 267	WM	
3.10.6	2701	(AB4)11,23,28,33 (AB5)292 (AC5)17 (AC5)160 (FQ/FR4)2	92	string cut		14-17	50 B 600	WM	
3.10.6	2942	(AB4)23,33	65		825EW	14-14-5	56	WM	
3.10.6	2949	(AB4)23 (AD5)4,7 (AC5)1 (FP6)153 (FQ4)7	65 92 110	string cut	RBRI	15-20	240 B 130	HM WM	
3.10.6	2950	(AB4)23 (AC5)39 (AD5)7,10,34,109,112 (CF4)56 (FS3)1 (TG5)4	69 92 94	string cut		14-20	311	WM	
3.10.6	2951	(AB4)23 (AD5)97 (FQ3)58	25 92	string cut mark upper pot		17-19	58 B 77	WM	
3.10.6	2960	(AB4)23	92	string cut	RBRIE	17	54	WM	
3.10.6	2961	(AB4)23 (AB5)317	92 94F			13.5-20	69	WM	
3.10.6	2962	(AB4)23	65			17	23	WM	
3.10.6	2964	(AB4)23	69			15	10	WM	
3.10.6	3004	(AB5)233 (AD5)34,102 (CE4)58	69 80 92 94C	string cut	825EICR 825EIW	17-26	113 B 115	HM WM	
3.10.6	3015	(AC5)17 (AD5)1	25 92			16-17	91	WM	
3.10.6	3016	(AC5)17 (AD5)97 (TG5)29	92		820IR	16-20	60	HM WM	1 deformed
3.10.6	+3019	(AC5)17,23,33 (AD5)34 (CF4)13	65 93 94 110		825ER	19-24	109	HM WM	
3.10.6	3055	(AC5)23,61,79 (AD5)4,7,34,93,149,241,255	69 92 92F 94			16-22	268 B 100	WM	
3.10.6	3079	(AD5)1	92			17	42	WM	deformed
3.10.6	+3088	(AD5)4	69			19	68	WM	salt encrusted
3.10.6	3151	(AC5)36,78 (AD5)55,80,112,152,190 (FQ3)58 (FR4)1 (HA2)124 gr. 282 (TG5)87	25 69 92 93		822R	15-22	308	WM	

Fig. no.	Type	Provenance	Fabric	Dec.	Surface treatment	Dia.	%	Man.	Comments
3.10.6	3201	(AD5)41	69	string cut		16.5	42	WM	
3.10.6	3212	98/1/4.51 (AD5)34	92 94			15.5-17	76	WM	
3.10.6	3214	(AD5)34,69	92 92L	string cut	CRR	13.10.5 5 B	88 B 60	WM	
3.10.6	3229	(AD5)34	92			15	40	WM	
3.10.6	3251	(AC5)28,37 (AD5)117 (FQ3)8 (FR3)13	92 94		820IR	17-19	241 B 25	WM	B knife trim
3.10.6	3333	(AD5)116	92			17.5	75	WM	
3.10.6	3669	(CF3)5 (TG5)68	110		910	23-25	10	HM	
3.10.6	4476	(CF4)107	92			6X6.4	100	WM	
3.10.7	2009	(AB4)6,14 (AB5)58,66,215 (AC5)12,14 (AD5)34,214,259 (BE2)1 (BF1)11 (BF2)1 (BF3)9 (FP6)1 (FQ4)80 (TG5)5/4	61 67 69 69F 92 94		820IR 825IW	12-23	213	HM WM	I deformed I B of HM IB?
3.10.7	2010	(AB4)27,31 (AB5)59,207 (AC5)55,58 (AD5)1,161,287 (BD2)78,81 (BF2)1 (BF3)8,38 (FQ4)37,48 (FR4)2,7,9 (TG5)91,116	65 69 92 117		820ECR 825EIGR RBRI RBRIE	12-21	237	HM WM	
3.10.7	2012	(AB4)11 (AB5)92 (AD5)198 (BE2)67 (BF2)1	92 93			12-20	53	WM	
3.10.7	2054	(AB4)11 (AB5)1,20,27,41B,52,58,59,207,322 (AB6)13 (AC5)39 (AC6)22,36 (BC3)3 (BD2)26,81 (BD3)33 (BE2)24,48,50,71,153 (BE3)65,132 (BE4)42 (BF1)16,28,56,73 (BF2)15 (CF4)133 (FQ4/FR4)2 (FR3)2 (FR4)9 (FS3)6 (ZH5)15	1 22 50 65 67 69 75 80 92 93 94 110		820IR 822R 825IR 825EIW RBRI RBRIE	12-31	532	HM WM	(AB5)52,58,59 999
3.10.7	2091	(AB5)32 (BF3)50 (TG5)65	92		820ICR 825ER	15-16	26	HM WM	
3.10.7	2125	(AB4)4,7,23,31,32 (AB5)20,25,27,32,40,63,65,66,67,69,70,71,92, 223,225,245 (AB6)1,7 (AC5)12,13,17,28,34,37,38,73 (AC6)20,30 (AD5)1,4,80,97,117,123,128,132,134,136,246 (BD4)17 (BE4)16 (BF3)20 (FP6)9,10,20,21,24,128 (FP7)5,15,17 (FQ4)2 (FR3)13 (FR4)1 (TG5)0,74	1 19 25 65 67 69 80 92 92F 93 94		820IR H820IR 825IR 910	13-22	1,768 B 2,317	WM	
3.10.7	2229	(AB5)91,94 (BE4)14,60 (BF1)56	67 92 94		822R	15-16 (30)	42	HM WM	
3.10.7	2244	(AB4)23 (AB5)70,347 (AC5)39,51 (AC6)23 (AD5)4,132,161,203 (BD2)47,79 (BE3)10,78 (BE4)19 (BF1)53 (FQ4)3 (FR4)7 (FS3)1 (TG5)73,74,87,91	69 80 92 92F 94 110		820IR RBRIE RBRI	11-27	289	HM WM	
3.10.7	2551	(AB6)7 (AC6)17	25 92			16-23	18	WM	
3.10.7	2560	(AB4)23 (AB5)32,86,229,252 (AC5)34 (AD5)1 (TG5)94	69 92 94		825IR 825IBL RBRI	15-21	188	WM	
3.10.7	2626	(AB4)23 (AB5)66 (AC5)23,131 (AC6)20,57,59,61 (AD5)1,87,262 (AD6)12 (BE3)55,130 (CE4)20,71 (CF3)2 (CF4)17,159 (FR3)12 (TG5)35	25 69 92 94 110	37g 1097	820IR 825ER 825IP 910 RBRIE RBRI	14-30	204	HM WM	CB
3.10.7	2682	(AB4)10,11,23 (AB5)59,230,231,233,239,252 (AC5)34,94,105 (AC6)36,54 (AD5)41,60,112,137,162,246,249,269,272,276,278 (AD6)11 (BC2)4 (BC4)1 (BE1)75 (BE2)88 (CF4)20 (FO7)2 (FP6)17,23,31 (FQ4)35 (FR3)13 (FS3)1 (FT3)4 (HA2)61 gr. 62 (TG5)74	69 80 92 92F		H820ER 820ER 820EW 820IR 822R 825ER RBRI RBR TOP	15-31	852	HM WM	

Fig. no.	Type	Provenance	Fabric	Dec.	Surface treatment	Dia.	%	Man.	Comments
3.10.7	2838	(AB4)23,28,31 (AB5)230 (AC6)30 (AD5)215,230,259,268 (AD6)13 (FO7)69 (TG5)74	69 92 92F 94 110		820IR 825ER RBRI	14-26	351	WM	
3.10.7	2839	(AB4)23,28,32 (AC5)28,34,36,38,39,46,49,79,80,94,99,103,127 (AD5)1,87,112,162,168,203,214,215,217,224,225,242, 269,272 (AD6)4,13,14,16 (BD2)81,100 (FP6)92,143,151 (FP7)17,35,52 (FT3)1 (JD2)1 (TG5)113	25 69 92 92F 94 110		825IW RBRI	16-27	1135	HM WM	
3.10.7	3046	(AB5)317 (JC3)6 (TG5)113	92 94 110		H820IR 825EI	17-21	24	HM WM	
3.10.7	3053	(AC5)23,37,38,51,73,93 (AD5)102,112,117,160,168,186,190,203,225,227,230,241,242,260 (FO6)46,52 (FP6)5,9,21,28,29 (TG5)74,114	69 92 94 94F		822R 825IR 825EIW RBRI	9-25	774 B 250	WM	(AC5)23 whole
3.10.7	3054	(AC5)23,37,38,39,45,46 (AD5)112,118,139,151,160	69 92 94		H820IR	16-19	359 B 1190	WM	(AC5)38 whole
3.10.7	3135	(AD5)7 (FP6)21 (TG5)1 (ZH5)48	69 92		822R	21-23	34	HM WM	
3.10.7	3230	(AD5)67	93		825EIW	18	23	WM	
3.10.7	3235	(AC5)37,38,127,145 (AD5)21,25,60,67,77,93,117,133,207 (FP6)10 (FQ4)7,20,21,48 (FQ/R4)2 (GD3)125 gr. 119/136 (TG5)65,91,95	69 92 92F 94 110		825ER 825EIR 910 RBRIE RBRI RBR TOP	15-23	807 B 190	WM	
3.10.7	3258	(AC6)61 (AD5)93,97,219 (TG5)113	69 92 94	242g	825IR	17-28	49 B 45	WM	
3.10.7	3272	(AC5)37,45 (AD5)131 (FP6)24 (FR3)23 (TG5)94	92 94			17-19	55 B 87	WM	
3.10.7	3305	(AD5)31	92		822R	19	47	WM	
3.10.7	3324	(AC5)34 (AD5)102 (FP6)29 (TG5)73,119	92	string cut	820IR RBRIE RBRE	15-18	53 B 30	WM	
3.10.7	+3326	(AD5)102 (FP6)34,143	92		820IR RBRI	13.10.5-19	106 B 100	WM	
3.10.7	3378	(AC5)73 (AD5)112 (FP6)31,49 (TG5)87,112	92 94		RBRI	19-20	89 B 30	WM	
3.10.7	3391	(AC5)45	94			18	63	WM	
3.10.7	3477	(AD5)164,219 (CF4)142 (FZ1)2	92 92F 94 106			14-22	44	HM WM	
3.10.7	3511	(HA2)79 gr. 210 (TG5)18,29,73	42 67 92			17-22	23	HM WM	
3.10.7	3620	(HA2)80 gr. 79,226 gr. 67 (JE3)1	48 112			18	14	WM	lid?
3.10.7	3802	(AD5)272 (FO6)1 (GD3)125 gr. 119/136 (TG5)46,113,117,132	92 92F 94		820IR	19-26	48	HM WM	
3.10.7	3906	(FP6)136 (FR4)1	92			16-21	22	WM	
3.10.7	4153	(FO6)50 (FP6)9	92			19-20	23	WM	
3.10.7	4175	(FP6)9	25			19	100	WM	

Fig. no.	Type	Provenance	Fabric	Dec.	Surface treatment	Dia.	%	Man.	Comments
3.10.7	4176	(FP6)21	25		H822R 910	20	16	WM	
3.10.7	4271	(FO6)61 (TG5)1,155	92 94F		RBRIE	23-26	31	HM WM	

3.11. Incense burners and miscellaneous forms

Incense burners – some ceremonial, others more likely everyday objects, for keeping *nimitti* or flies at bay. The hole in the stand is to allow the fire in the bowl to draw better (for a modern local parallel, see Plate 3.11.1). Bread cones occur throughout the site, but in particular concentration in grid square (TG5) and Areas C and B, but hardly at all in Area F, and only one in Building F1. Pot stands; feeder cups; spouts; possible lamp forms (note discussion on reused RBR bowls for this purpose, section 3.7); crucibles – some of these may actually have been used as lamps – considering the repertoire of Medieval lamps (for a wide array of forms used for this purpose, see Cedro 2014, pls 1 & 3); miniature pots; lids – a large number of dishes and offering dishes can have been used as lids and probably were; here only a handful of forms are shown that more clearly were made to function specifically as lids; unusual forms and appliqué animals; forms of unknown function.



Plate 3.11.1. Modern 'braziers', similar in design to the ancient ones.

3.11.1 The largest of the braziers/incense burners

+2645x: With decorated conical supports for a pot, whose diameter at the base must have been a minimum of 40cm, (if used for cooking), or for decoration only. The upper part is square in plan. Cf. Beg.W.453 (50-60? AD 25-184) fig. G9, 23-2-289a, although there is no stratigraphic reason to date 2645x later than the Napatan period. In the Mediterranean area related forms of braziers are found in Hellenistic contexts, for example at Sidi Krebish (Benghazi, Libya, Riley 1979, 309, fig. 114, pl. XXXVII). An even more elaborate example has been found in the sea off Cape Boeum on north-west Sicily (now in Museo Archeologico Baglio Anselmi, Marsala).

3.11.2 Incense burners and/or braziers

+2495x: Beg.S.503 (29, 297-284 BC) fig. 16, 22-1-71d, large bowl with white plaster-like substance on the exterior, presumably similar to the lining in bread ovens.

4445x: Bar.6 (44, 56-43 BC), fig. 66, 16-12-368.

3.11.3 Wheel-made incense burners

Medium size. These are also commonly found in funerary contexts, see RCK passim, but will also have had a ceremonial or practical use. Note that this form is often found made in two parts, the lower stand with a hole made before firing in the wall (e.g. Laming Macadam 1955, II, pl. XXXII. 17 [2045], Napatan; also Nu.26 (12, 553-538 BC), fig. 110, 18-3-192 ditto MFA acc. no. 20.4800, 555-542 BC) and a bowl to perch on top, but in the course of the recent excavations at Kawa many unified forms have been found.

2654x: Nu.47 (16, 503-478 BC) fig. 131, 18-1-158; Laming Macadam 1955, II, pl. XXXII.12a (but more squat), Napatan nevertheless.

2703x: Nu.40 (10, 593-568 BC) fig. 86, 17-12-123; Nu.47 (16, 503-478 BC) fig 130, 18-1-158.

+3203x: Beg.W.818 (4-6, 701-653 BC) fig. A.23, 23-3-599a, central part only; Laming Macadam 1955, II, pl. XXXII. 17 [2045], Napatan.

+3203x and 2568x: Nu.26 (12, 553-543 BC [MFA: acc. no. 20.4800, 555-543 BC]) fig. 110, 18-3-192 and Nu.3 (8, 643-623 BC) fig. 28, 16-12-240, but apart from being tall and thin, these two examples show no sign of the central 'basket', but are rather just stands for a detached bowl to be placed on top; Bar.10 (48, 10-0 BC), fig. 76, 16-2-402. Complete stand with hole, Nu.48 (24, 362-342 BC) fig. 185, 17-3-633.

+3249x: Beg.W.308 (50-60, AD 25-184) fig. H11, 23-1-296; Vila 1980, fig. 115.1 grave 2-V-6/259, Napatan. A similar incense burner, but with central section convex rather than concave, Bar.8 (32.I, 263-248 BC) fig. 32, 16-2-382.

4586x: Heidorn 1994, 126, fig. 5.f (but thinner wall, white slipped exterior and represented as a rim), early Napatan period.

3.11.4 Handmade and wheel-made incense burners and/or braziers

No direct parallels found, but 4185x, which appears to have a square cut out, may be a precursor to the (later) incense burners/ braziers from Meroe, with patterns cut out of the wall (Beg.W.139 (50-55, AD 25-115) fig. I.1, 22-2-288, fig. I.3, 22-2-287; W.179 (55-65, AD 93-246) fig. I.6, 22-2-399; W.214 (50-55, AD 25-115) fig. I.4, 23-1-72; W.390 (50-60, AD 25-184) fig. I.5, 23-2-92).

3.11.5 Handmade incense burners, with solid stem where this survives; also coarse lamps and brazier fragments

2487x: Form and rim decoration is reminiscent of Vincetelli 2006, fig. 2.68 420, Hillat el-Arab grave ARA 15, an incense burner assigned a date of the 12th-10th centuries BC.

2542x, 3719x and 4829x: Nu.36 (5, 690-664 BC) fig 10,

17-2-1853, coarse brown ware, solid footed 'cup'.

2757x: Laming Macadam 1955, I, 162, 'pottery four-footed dishes', found on the 'Site' and in Temple T (of Taharqo), but no stratigraphic information is given to specify the dating, and neither are they illustrated.

2848x: Mohamed Ahmed 1992, III D2, second half of 6th to end of 5th centuries BC.

+3863x: The (illustrated) specimen from (AD5) 283 has broken bosses around its rim or possibly the base of an appliqué animal?

+4100x: 'Footed cup' incense burner with a solid base, Ku.71 (3, 716-701 BC) fig. 34b, 19-3-1494, pl. 43c 2/1, coarse red ware.

4611x: The form and to some extent the external decoration are similar to Vincentelli 2006, fig. 2.68 420, Hillat el-Arab grave ARA 15; see also 2487x above. The visual parallel is close, but the dating of ARA 15 is to the 12th-10th centuries BC although another bowl found within the tomb is Meroitic (ibid, fig. 2.66, 403), so the tomb contents are not exclusively of the Third Intermediate Period. Note the fragmentary punctated decoration on the underside. This form of discreet decoration is referred to in Laming Macadam 1955, I, 162 in relation to four-footed dishes found on the site, but without illustration or dating, although the implication is that they are of Napatan date.

3.11.6 Handmade incense burners made as two bowls joined at the base

These chiefly occur in Room XII in Building F1; also miscellaneous handmade bases of incense burners. Note that because of the similarity between the rims or bases of the full profiles and 'ordinary' bowl forms in section 3.8, across figures 3.8.1-3.8.8, more of these double forms may exist elsewhere on the site, as it is only when the join between the upper and lower parts is present that it is apparent; otherwise they appear to belong to 'normal' pots. There are two main types of these coarse incense burners/braziers:

+4710x (height 31 cm), which is open in the middle, and thus could only have functioned as a support for a bowl or dish placed on top, and would then have functioned as a brazier;¹ **+4729x**, which has a middle section, made up of the base of the lower of the superimposed bowls. The upper bowl could then have been used for burning incense, aromatic wood or something altogether different. Certainly the bowl here is much deeper than in the custom-made incense burners in 3.11.3, and a different process may well have been intended. Would it have been possible to smoke food, for example, given that the fabric is quite porous?

3.11.7 Bread cones and pot stands

The bread cones are always handmade, usually of Fabric 25, the pot stands wheel-made. Bread cones 2324x, 2482x and 4497x are Meroitic, as are 3610x and 4320x. The rest are most likely Napatan in date, especially the complete profiles (Kirwan 1936, 204, fig. 2). They conform with the typology published by Jacquet Gordon (1981, fig. 6, p. 21 ff.),

¹ For much more sophisticated examples of these open braziers, albeit of a much later date, see above, 11.4.

and the few forms in the present type series offer no reason to expand it. Some of the bread cones have an oblique or vertical groove on the exterior (3610x and 4320x, 3.11.7), as if they have been twisted or pulled out of a mould (?).

143x: Orzechowska 2003, pl. 22c, Late Napatan.

2280x and **2311x:** Orzechowska 2003, pl. 22.o, Napatan.

+2601x: Note the red, white and yellow paint splashes on this pot stand (not shown in the drawing, see photo), as if it was used close to where wall frescoes were being painted; judging by the direction of the dribbles, it has also been used either end up. Nowotnick 2018, fig. 11, after Shinnie and Bradley 1980, 112, fig. 42. Almost identical, except that the Meroe example is almost twice the size. For more medium-sized pot stands with a vertical profile: Laming Macadam 1955, II, pl. XXXII.18 [2030], Napatan; Nu.49 (18? 458-453 BC) fig. 146, 18-1-72.

2630x and **2693x:** Laming Macadam 1955, II, pl. XXXIII.a [2069] and b [2044], Napatan.

3610x: Orzechowska 2003, pl. 22a, Napatan.

4497x: Laming Macadam 1955, II, pl. XXXIII.d, Meroitic.

+4654x and **+4661x:** Ku.17 (2, 751-716 BC) fig. 22b, 19-4-175.

4654x: Török 1997, I, 124 II fig. 89 269-1 (upper half only), dating to after the mid 3rd century BC-1st century AD.

3.11.8 Feeder cups, spouted bowls and possible lamp forms

Feeder cups: **2622x** and **2605x:** Ku.62 (3, 716-701 BC) fig. 33b, 19-3-1571. See also Beg.W.306 (50-60, AD 25-184) fig. F29, 23-3-180; Beg.W.390 (50-60, AD 25-184) fig. F30, 23-2-979.

2631x and **2731x** (spouts): e.g. Vila 1980, fig. 125.3, type II-2, Napatan.

2985x: spouted vessel: Beg.W.270 (50-60? AD 25-184) fig. F27, 23-1-335; Ku.8 (1, 760-751 BC), fig 15b 19-2-272, but may be part of grave goods from Ku.20 (2, 751-716 BC).

+3021x: Same general type of vessel, but handmade and with impressed decoration: Beg.S.4 (28, 315-297 BC) fig. 11, 20-4-69; a much closer parallel, Beg.W.5 (46-47, 26-10 BC) fig. C.27, 23-1-158; also wheel-made, but not identical, Beg.W.185 (45-55, 43 BC-AD 115) fig. H.2, 23-1-115; Bar.20 (49-55, AD 0-115) fig. 100 16-2-446, polished RBW (handle joins to body lower down); Bar.1 (44, 56-43 BC), fig. 69, 16-2-282, polished RBW.

4827x: Aston 1999, pl. 19.556, Libyan period, 1000/950-750/700 BC; Boulet 2017, fig. 3.g; 2018b, fig. 4.h, Theban, phase 2, late 8th to early 7th centuries BC; Vercoutter 1970, fig. 49 b; Ku.71 (716-701 BC) fig. 34b, 19-3-1494.

3.11.9 Crucibles, possible lamps

Miniature pots, salt cellars (?), unusual bases (cf. Fantusati *et al.* 2014, pl. III, fig. 1 AE11/I-R3/1, and for similar, but Medieval forms, Cedro 2014).

A number of the small vessels at the top of the figure were recorded as possible crucibles – 2680x, 4704x, 4725x and 4731x – but none exhibit any traces of vitrification or heating at high temperatures. What use these small pots may have been designed for remains uncertain.²

² One vessel identified as a crucible was recovered from the surface

It should be noted that the crudely manufactured small bowls that may or not have been intended for use as lamps did however not show any trace of burning (or lamp fuel).

2180x: Jacquet Gordon no date, Nile silt, fig. 7.9, Saite Period (c. 664-525 BC).

2232x and **2260x:** Both have a small hole just below the rim and 2232x also has a hole near the base, on the opposite side to the rim hole. The purpose of this arrangement is unclear.

2282x: Bears a passing resemblance to so-called salt cellars in the Archaic Greek pottery repertoire, cf. Lynch 2011, 265-266, fig. 122, c. 500 BC.

2751x: This type has been placed here as it has a base hole located near to but not in the base, but the fact that it is wheel-made suggests that it belongs to quite a different form than those nearby. On the other hand, it does not resemble other base forms.

2850x: Evina and David 2011, 305-306, fig. 1.1 and 1.2. One not very convincing theory is that it is a Meroitic bread cone variant? Given its rarity at Kawa, this would seem unlikely. See also Reisner 1918, fig. 32 for the same form at Nuri, in a foundation deposit, and Nu.24 (10, 593-568 BC) fig. 79, no registration number; Nu.42 (10, 593-568 BC) fig. 88, 18-2-204. There are further occurrences across RCK.

2871x: Ku.2 (24, 362-342 BC) fig. 9a, 18-3-819; Ku.1 (24, 362-342 BC) fig. 7a, 19-4-227; Beg.W.818 (4-6, 701-653 BC) fig. A28, with a round base; Nu.5 (12, 553-538 BC) fig. 108, 18-4-14; Nu.9 (11, 568-553 BC) fig. 93, no registration number, but from a foundation deposit; Nu.10 (14, 533-513 BC) fig. 118, 17-4-718; Nu.26 (12, 553-538 BC) fig. 110, 17-4-1163; a similar vessel in the MFA online collection is dated 510-478 BC (acc. no. 20.4325, from Nu.47); French 2004, 92, 97, Type 3 – larger dimensions, but form very similar, found at Buto, dating to the second half of the 6th century BC.

3083x: Aniba, Napatan burials, I.C.4.f.1 grave SA 29 (E 11309) Hembold-Doye and Seiler 2019, 140.

+4150x: Miniature pot from Room I in Building F1; contained a resinous substance.

4835x: Aniba, Napatan grave S 48, 6975, VI.2.7 ‘sackförmiges Gefäß’ Hembold-Doye & Seiler 2019, 351, wheel-made.

3.11.10 Lids, broken-off animal appliqués and special forms with ‘legs’(figurines or pots?)

For other animal figurines which may have been attached to pottery vessels, see *infra*, Chapter 4 and Welsby and Taylor forth., cat. nos F-481, F-482, F-484, F-485 and F-491; see also the human figurine F-495.

2620x: Laming Macadam 1955, II, pl. xxxv [2152]; A much finer faience example of a ram’s headed jar stopper from Barkal B5021.I2, MFA acc. no. 21.3097. A wheel-made



Plate 3.11.2. 2952x (3.11.10) next to a modern lid of an aluminium cooking pot.

lid of the same approximate size has also been found on Cyprus, dating to the Archaic period (750-475 BC) (on display at the St Barnabas Museum, Tuzla, Turkish Republic of North Cyprus).

2672x: Ku.18 (4, 701-690 BC) fig. 23c, 19-3-822.

2952x: No direct parallels have been noted, apart from its striking resemblance to a modern aluminium cooking pot lid (Plate 3.11.2).

4108x and **4705x:** Small, slightly concave ceramic discs or tiny dishes; to be used as lids? Original manufacture, rather than ground down from larger sherds.

4727x: The knob of some form of lid, it resembles for example Vila 1982, fig. 22 (Meroitic), although this is a much more refined example, and not necessarily contemporary.

3.11.11 Miscellaneous forms with uncertain function

2446x and **3426x:** Most likely part of the same vessel/object, with smooth exterior and a round groove inside. 4447x is a similar form, but its function is also unknown. A curving ceramic pipe, assuming the hollow interior was enclosed? The former comes from a domestic context, while the latter was found in a pit in the cemetery.

4325x: Mohamed Ahmed 1992, III D2, 5th century BC. The vessel/object appears to have had feet, like 2757x (11.5), but is much larger.

in the cemetery during the survey in 1993 (Welsby 2001c, 262, cat. no. 234, fig. 7.3).

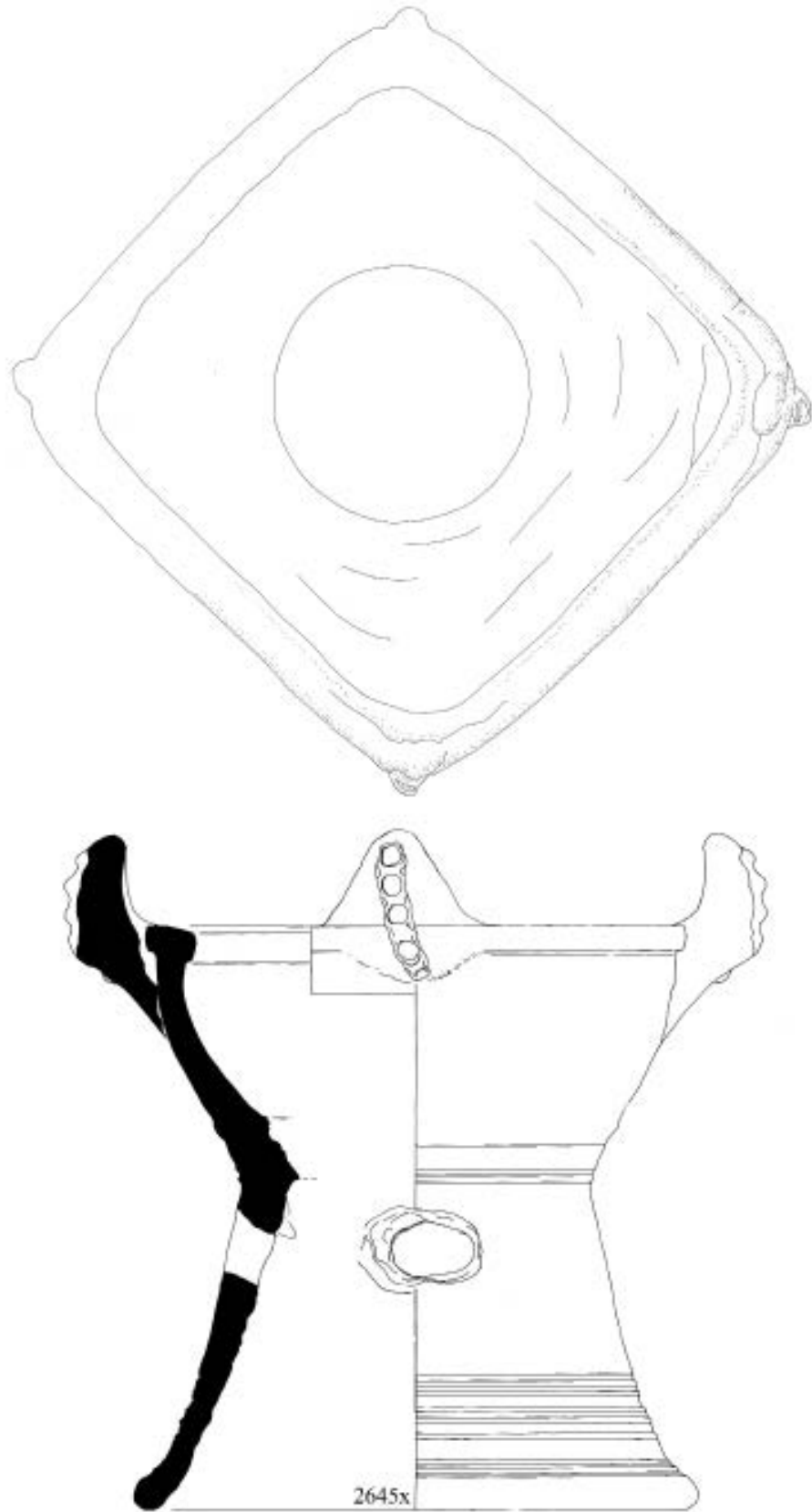

Figure 3.11.1. The largest of the braziers/incense burners (scale 1:4).

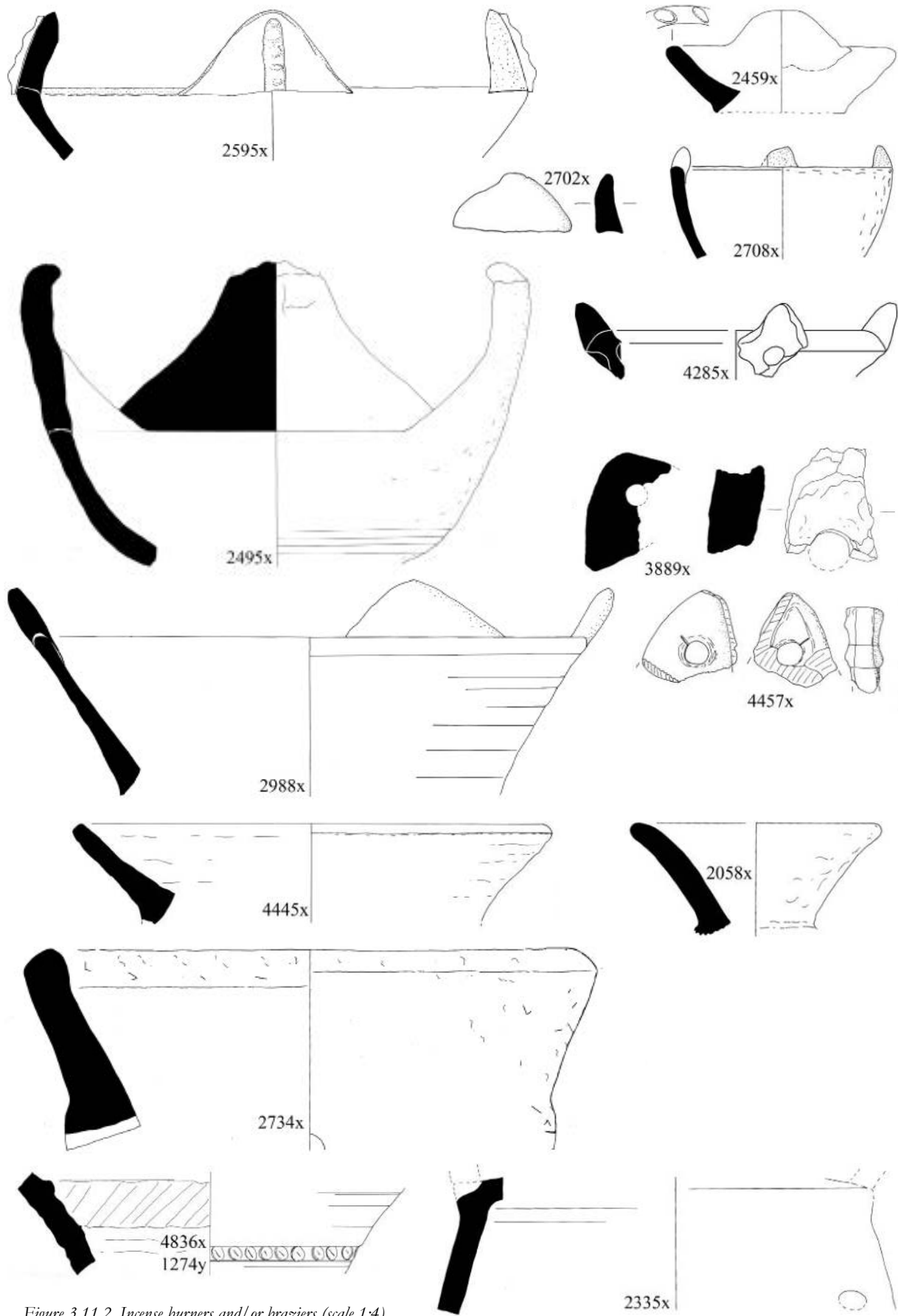

Figure 3.11.2. Incense burners and/or braziers (scale 1:4).

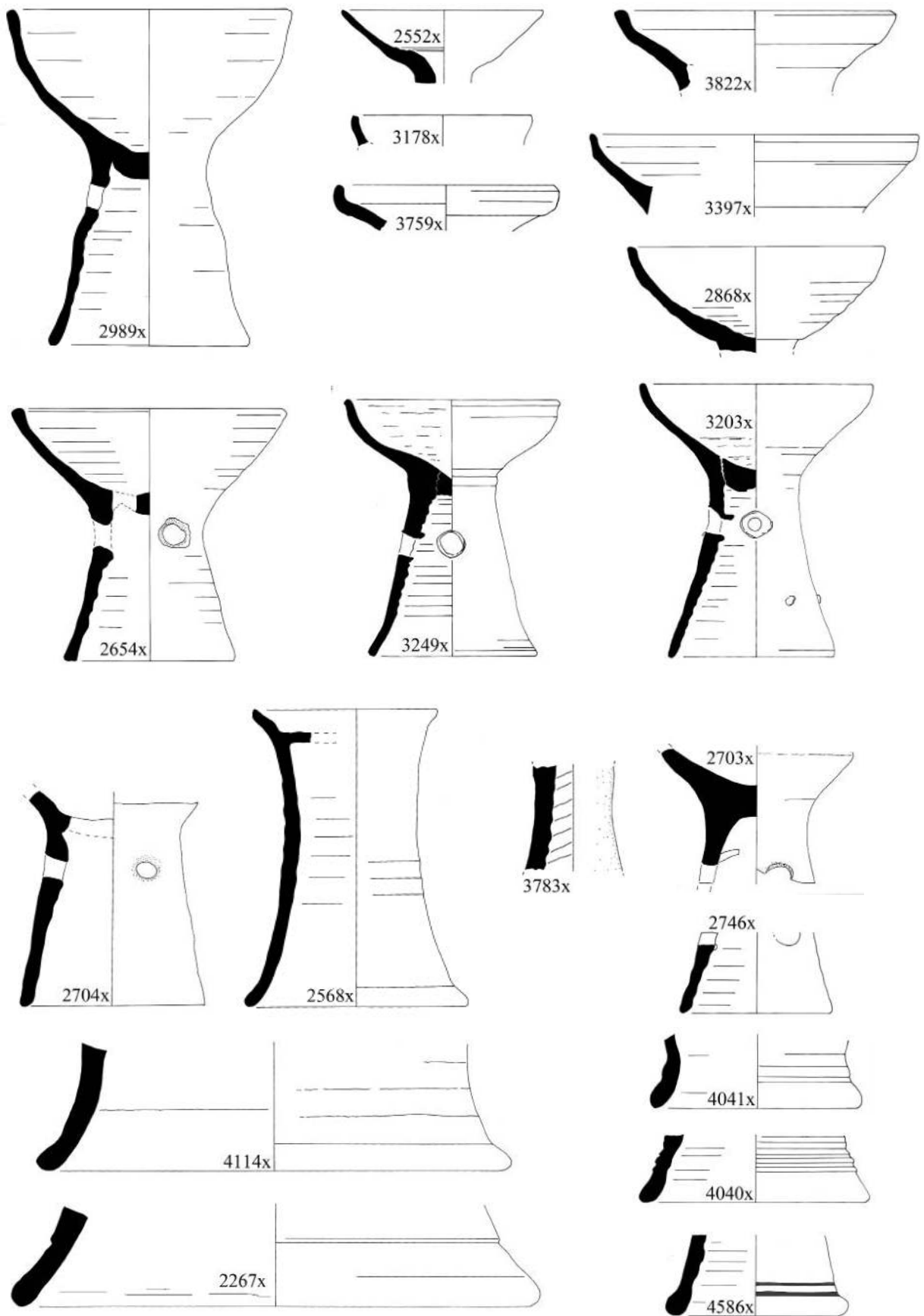

Figure 3.11.3. Wheel-made incense burners, medium and large size (scale 1:4).

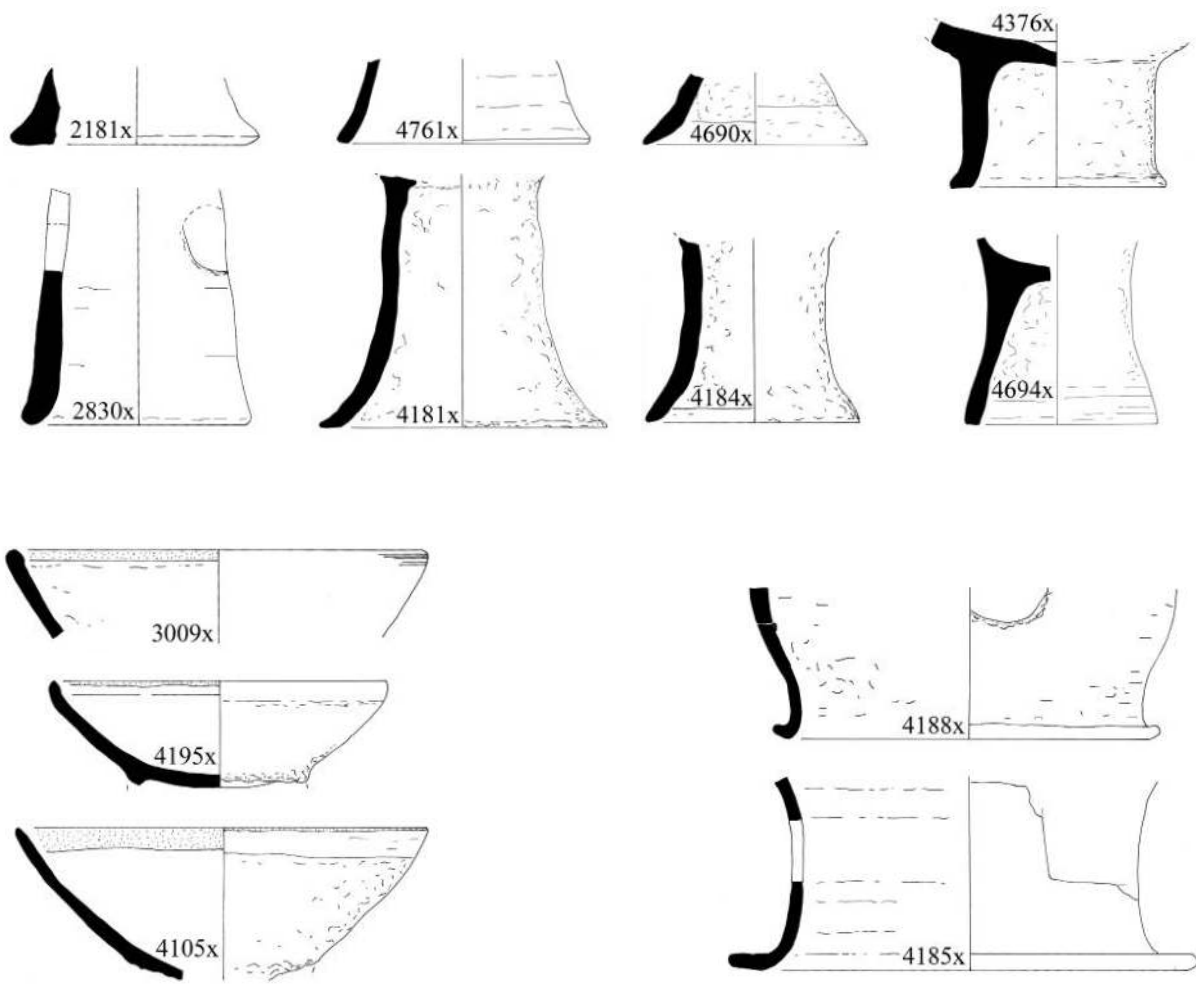

Figure 3.11.4. Handmade incense burners and/or braziers (scale 1:4).

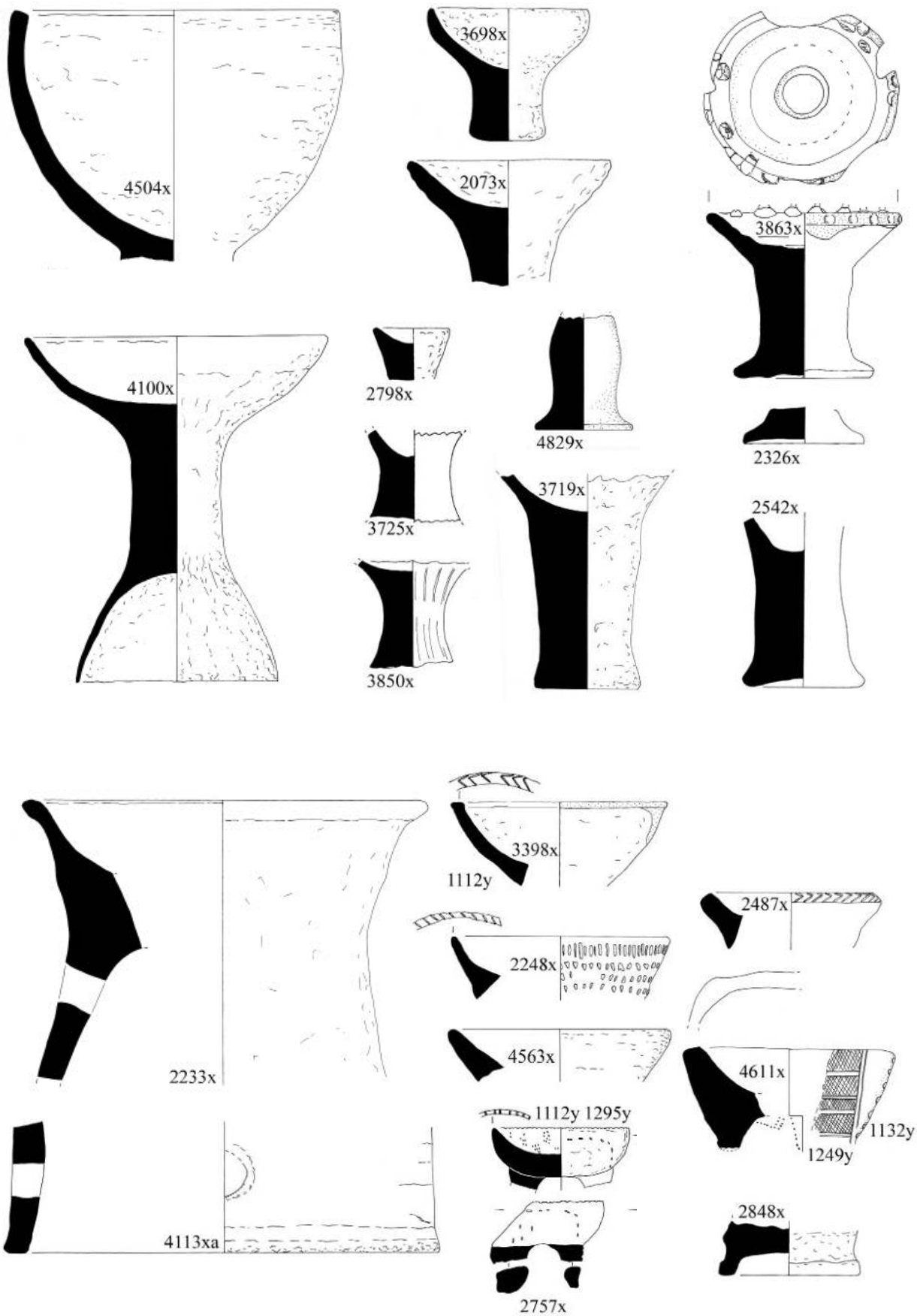

Figure 3.11.5. Handmade incense burners (scale 1:4).

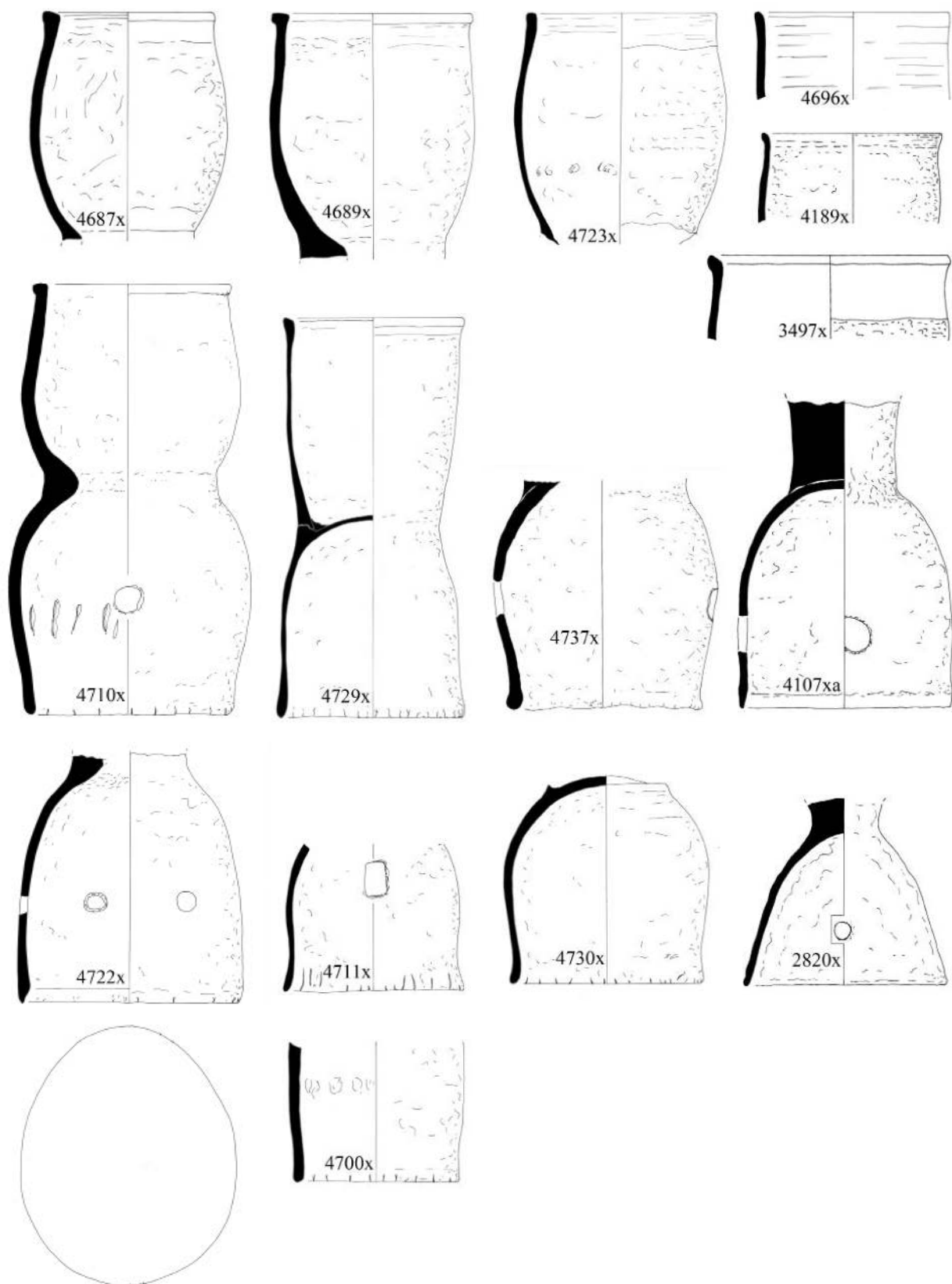

Figure 3.11.6. Incense burners and/or braziers, similar forms with open or closed profile (scale 1:4).

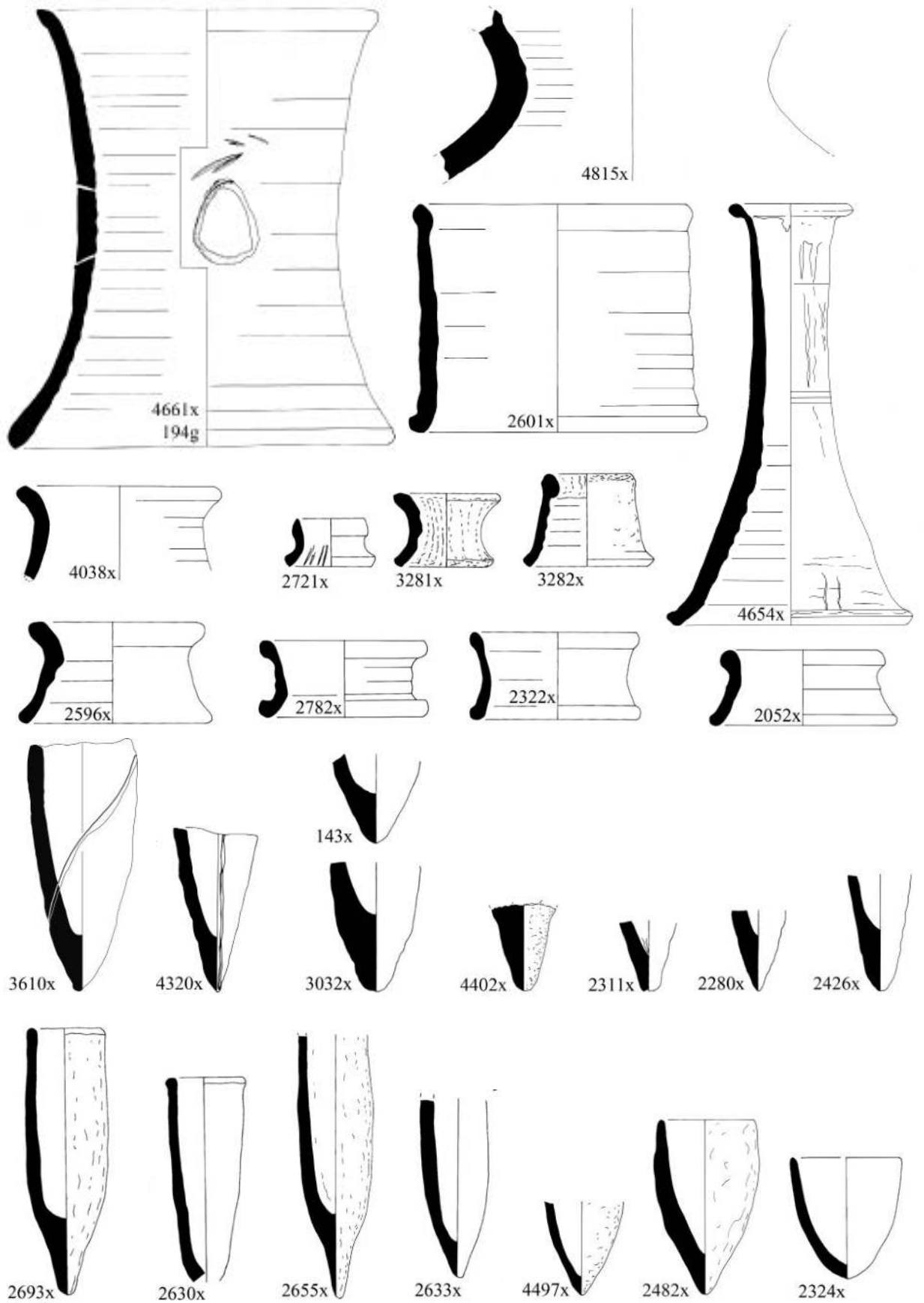

Figure 3.11.7. Pot stands and bread cones (scale 1:4).

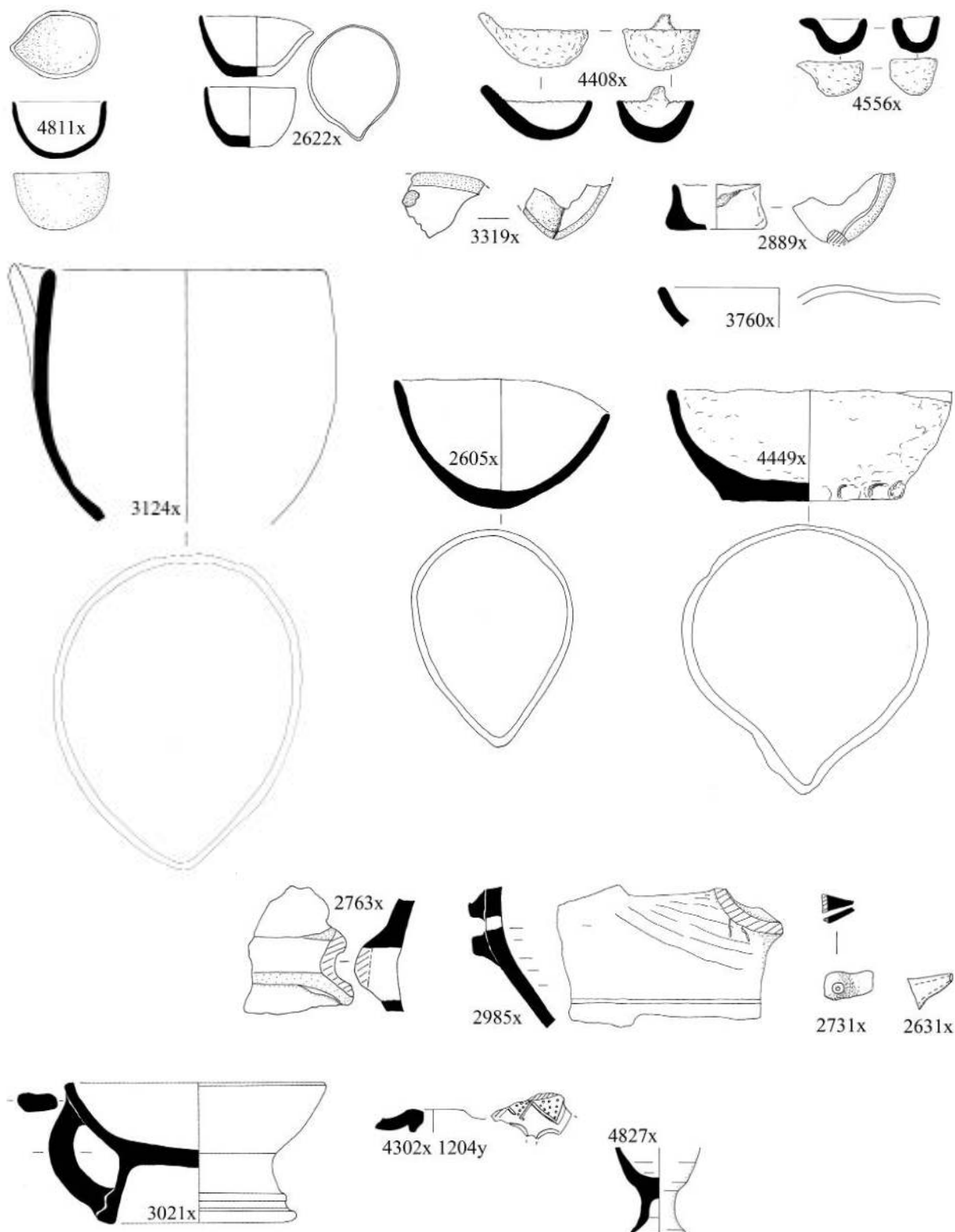

Figure 3.11.8. Feeder cups, spouts, possible lamp and goblet forms (scale 1:4).

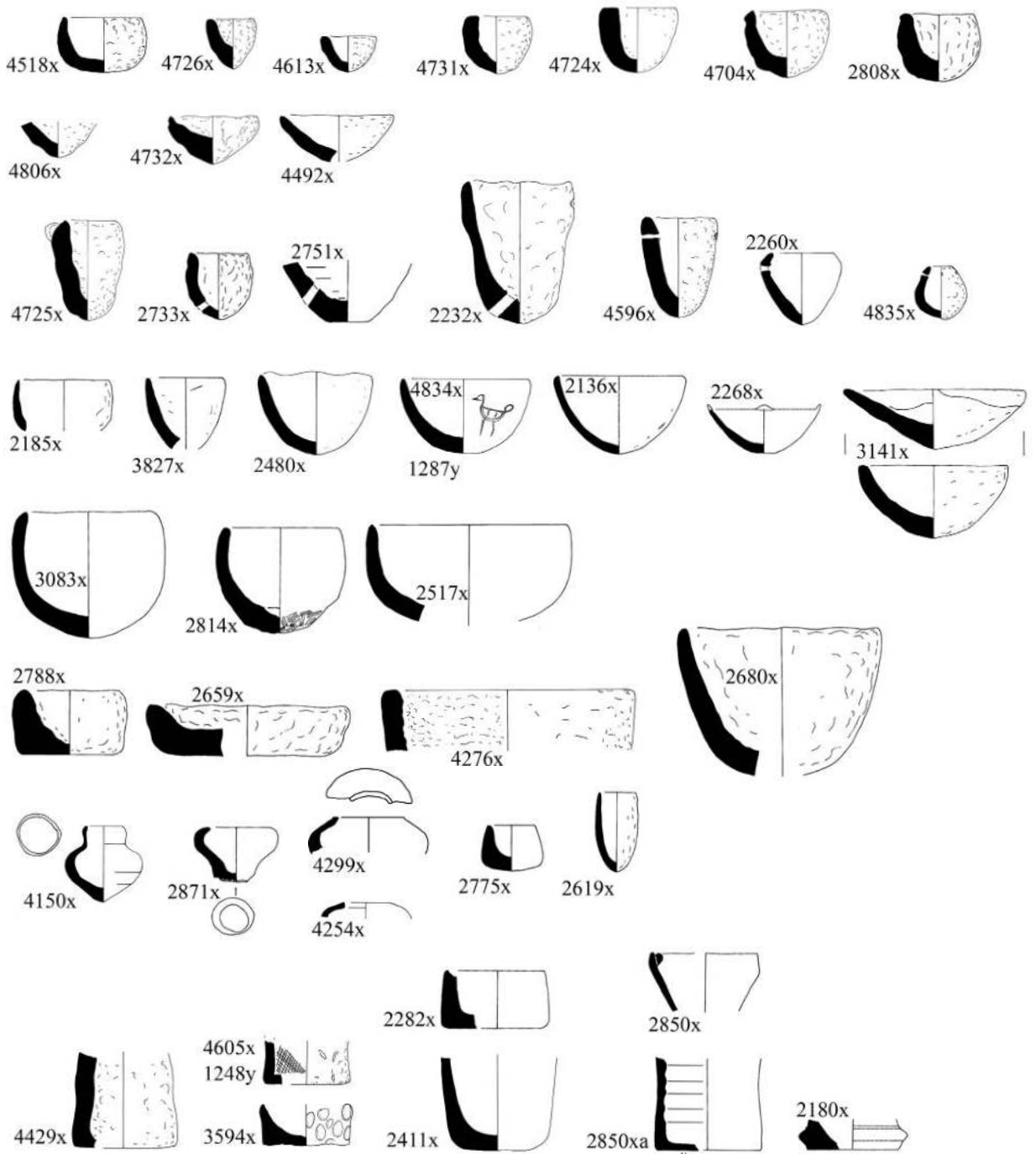

Figure 3.11.9. Crucibles, possible lamps, miniature pots, unusual bases (scale 1:4).

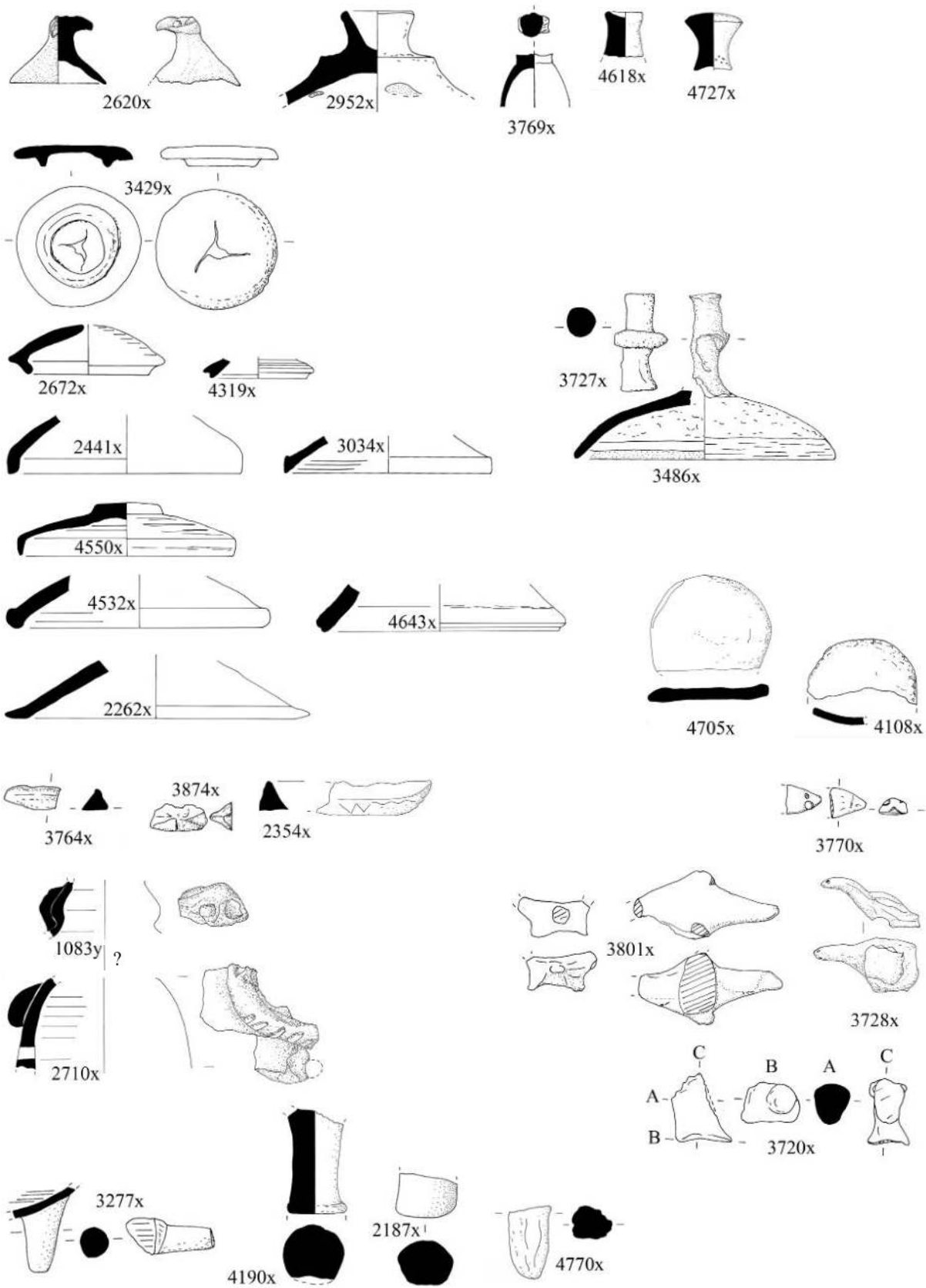

Figure 3.11.10. Lids, animal appliqués and special forms with 'legs' (scale 1:4).

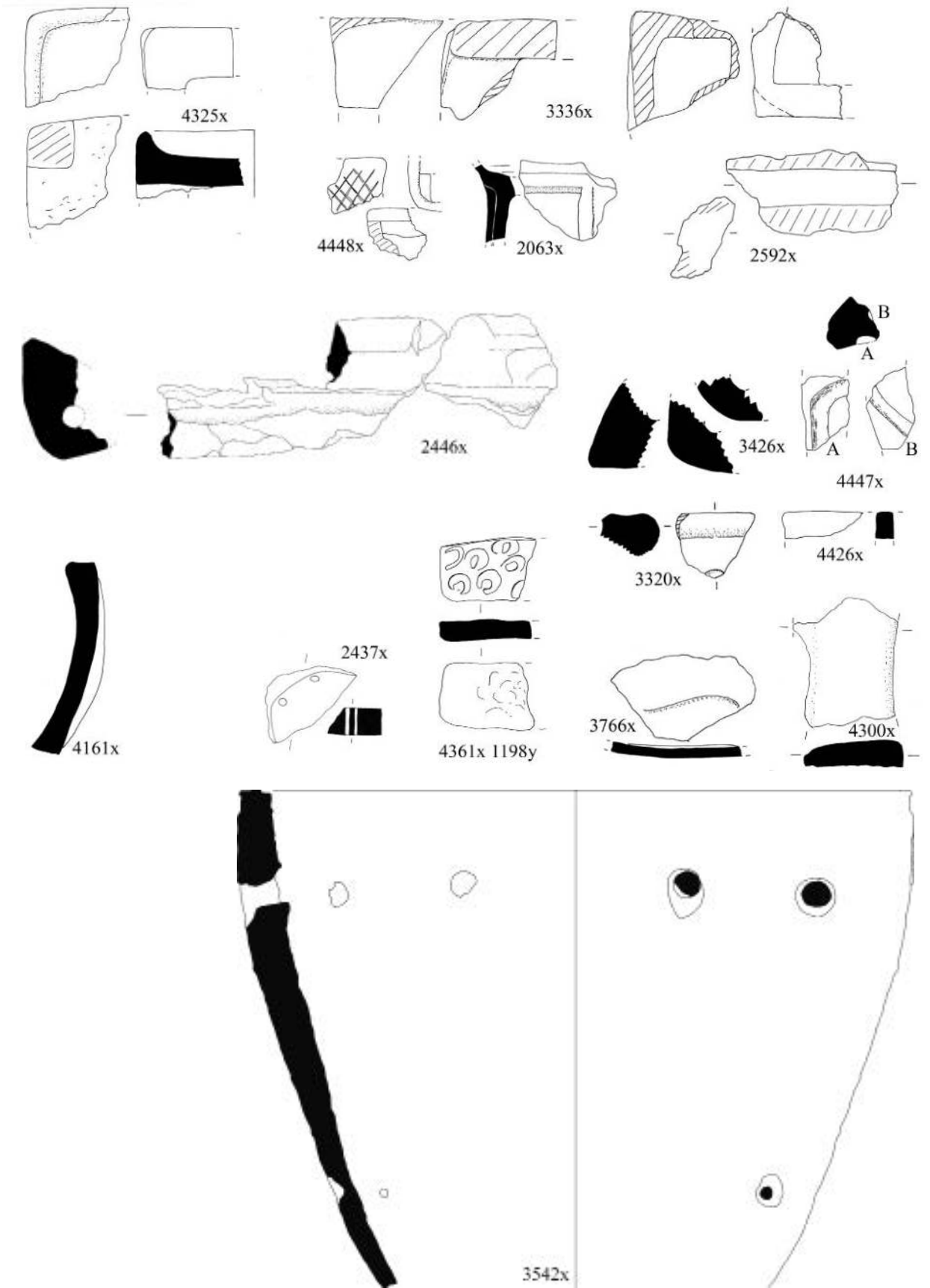

Figure 3.11.11. Miscellaneous form of unclear function (scale 1:4).

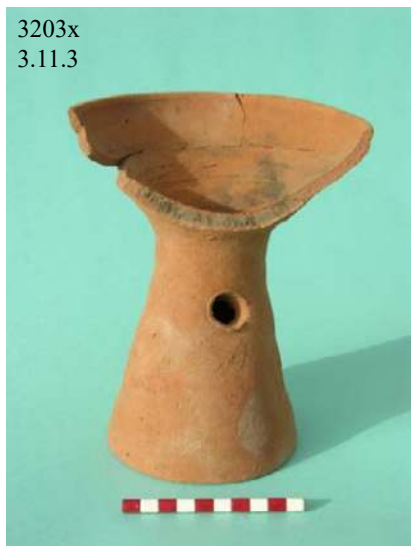

Plate 3.11.3. A selection of the best preserved incense burners/ braziers.

4100x
3.11.5



Plate 3.11.4. Handmade incense burners and braziers used for heating food (?).

3863x
3.11.5

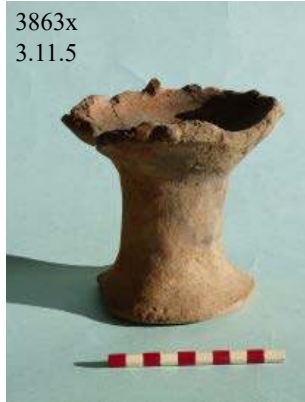

4689x
3.11.6



4710x, 4729x and 4737x
3.11.6



4654x
3.11.7



Plate 3.11.5. Pot-stands, spouted cups, a lamp (?) with handle, a miniature pot, an unfired bowl and a lid with a tall handle.

4661x
3.11.7



2601x
3.11.7



3021x
3.11.8



3124x
3.11.8



4449x
3.11.8



3486x
3.11.10



4150x
3.11.9



4834x
3.11.9

TABLE 3.11. INCENSE BURNERS AND MISCELLANEOUS FORMS.

Fig. no.	Type	Provenance	Fabric	Dec.	Surface treatment	Dia.	%	Man.	Comments
3.11.1	+2645	(AB4)5,14 (AB5)68,(AC5)46 (FO6)155 (TG5)1,5/4	1 71 92	871	820ER 820IP	32-44	81	HM SW WM	(AB4) (AB5) & (AC5) 999
3.11.2	2058	(AB4)23 (BF2)15	21 94			37	8	WM	
3.11.2	2335	(BD2)63 (BE2)110 (BE3)10	67 69 94	871	822R	19-28	43	HM WM	
3.11.2	2459	(BE3)10	1	1017		-	-	HM	
3.11.2	+2495	(AB5)1,27 (AC5)127	92		822W	22	8	HM WM	
3.11.2	2595	(AB5)68,91,94	1		RBRI,R & Y	36	11	WM	999
3.11.2	2702	(AB4)11 (BE2)158 (FP6)89	1 69 92					HM	
3.11.2	2708	(AC6)12 (CE4)71	1 92			15-17	20	HM	
3.11.2	2734	(BE1)7 (BF1)4	71	871 45mm		34	25	HM	999
3.11.2	+2988	(AB4)23,31 (AD5)34	1 92		820IR 820IW	42	84	HM WM	lug 822R
3.11.2	3889	(FQ4)88	110	851		-	2	WM	
3.11.2	4285	(TG5)120	92	851		-	-	HM	
3.11.2	4445	(JG1)13 gr. 12	92			35	12	WM	
3.11.2	4457	(CE4)42 (CF4)59 (TG5)46	92	851		-	-	HM	
3.11.2	4836	(AB5)68	1	1274		-	-	WM	
3.11.3	2267	(BE3)10 (BE4)12	2 92			28-39	14	HM WM	
3.11.3	2552	(AB4)1	92			15	8	WM	
3.11.3	2568	(AB5)32,66 (CE4)37,88 (FP6)9 (TG5)91	92 92C			12.5-30	161	HM SW WM	
3.11.3	2654	(AB4)6,7 (AC5)112 (AC6)54 (AD5)246 (TG5)87	92 94 110	871	RBR TOP	13-17	61	HM WM	
3.11.3	2703	(AB4)11,23,33 (AC5)24 (BD2)101 (FP6)31	69 92	871		8	60	HM WM	waist Dia
3.11.3	2704	(AB4)11,23 (AC5)23 (CE4)20	69 92	871	825EW	7 10	113	HM WM	waist Dia
3.11.3	2746	(BF1)28	65	871		11	39	WM	
3.11.3	2868	(AB4)23,33 (AB5)322,328 (AC5)18,38 (AC6)36 (CF4)17 (FQ3)8 (TG5)94	92 110	1112	820IW 825IR RBRI	15-32	110	HM WM	
3.11.3	2989	(AB4)23 (FQ3)8 (TG5)94	92	871		15-21	63	HM WM	
3.11.3	3178	(FR3)1	67			16	6	HM	
3.11.3	+3203	(AC5)49,53 (AD5)28,69,87,139,264 (CF4)55 (FQ4)116 (FR4)2 (TG5)73	92 94 94F	871	H820IR RBRIE	16-22	121	HM WM	
3.11.3	+3249	(AC5)28 (TG5)94	92	871		17-17	54	WM	
3.11.3	3397	(AC6)61	92			19	16	WM	
3.11.3	3759	(AC5)53	92			16	10	WM	
3.11.3	3783	(AD5)207 (TG5)7	92		820EP 820EW	-	-	WM	
3.11.3	3822	(AD5)264 (FP6)57	92 110			20-30	27	HM WM	
3.11.3	4040	(TG5)87	92			17	15	WM	
3.11.3	4041	(TG5)91	67 92			15	42	WM	
3.11.3	4114	(FO6)100	25			35	10	HM	oil-stained
3.11.3	4586	(CF4)102	94	832BR	825ER	12	13	WM	
3.11.4	2181	(BE3)57	1			14	8	-	IB?
3.11.4	2830	(AC6)22	92	871 x 2		13	55	HM	
3.11.4	3009	(AB5)239	92			23	8	WM	contained burnt sand

Fig. no.	Type	Provenance	Fabric	Dec.	Surface treatment	Dia.	%	Man.	Comments
3.11.4	4105	(FO6)62	110		RBRI	23	31	HM	
3.11.4	4181	(FP6)31	110	871?		16	35	HM	
3.11.4	4184	(FP6)31	110			13	10	HM	
3.11.4	4185	(FP6)31	110	SQ 871	825EICR	30	15	HM	
3.11.4	4188	(FP6)34	92	871		20	25	HM	
3.11.4	4195	(FP6)57	92		RBRI	19	22	HM	
3.11.4	4376	(CE4)4 (CF4)19	67 92		825EIR	9-12	29	HM	
3.11.4	4690	(FP6)138,154	105C 110			9-14	75	HM	
3.11.4	4694	(FP6)188	92			11	100	HM	
3.11.4	4761	(FP6)70,169	110		825EIBR	11-14	30	HM	
3.11.5	2073	(AB5)63,86 (AD5)235 (BE3)10,16	1 11 69 92	1139	820EW	6-15	238	HM WM	
3.11.5	2233	(BE4)16,19,60	1 92	871		30-31	16	HM	
3.11.5	2248	(BD2)23 (BE3)78	1	1014 1112	830IP	13-16	33	HM	
3.11.5	2326	(BE4)9	92			9	21	WM	
3.11.5	2487	(BE3)16	1	1033		12	15	HM	
3.11.5	2542	(AC5)73,126 (BE2)103 (TG5)114	67 71 92 110			8-9	163	HM	
3.11.5	2757	(BF1)72	1	1112 1295		10	13	HM	
3.11.5	2798	(TG5)1,12	92			5-9	70	HM	
3.11.5	2848	1075 4	12			10.5	46	HM	
3.11.5	3398	(AC5)61	110	1112	825ER	16	14	HM	
3.11.5	3698	(BF3)8 (JG2)18 gr. 2	25 92		802	10-13	51	HM WM	
3.11.5	3719	(AD5)241	92		820ER	7.5	100	HM	
3.11.5	3725	(AC5)102 (AD5)242 (FP6)153,171 (FZ2)1	67 92 92C 110		820ER	5	40	HM	
3.11.5	3850	(AC5)102,128	67 110			4.5	102	HM	
3.11.5	+3863	(AD5)283 (FO6)71 (TG5)5/4,7	67 92 92C 110		805E OBL	8-14	133	HM WM	
3.11.5	+4100	(CE4)1 (CE5)1 (FN6)3 (FO6) 47,48,53,54,61,62,66,91,92, 98,167 (FP6)1,21,37	92 110	200 1142	910 RBRI	14-15 B 17-23 R	172	HM	(FO6)47 & 92 999
3.11.5	4113a	(FO6)100	25	871		27	14	HM	
3.11.5	4504	(CF4)128	92			35	28	HM	
3.11.5	4563	(CF4)145	92			16	11	WM	
3.11.5	4611	(TG5)5/4	92	1132 1249		-	-	HM	
3.11.5	4829	(JD3)2	106			6.5	80	HM	
3.11.6	2820	(AB5)59 (FO6)62,92	69 92C	871	825EIW	7-14.5	130	HM	
3.11.6	3497	(AD5)230,272 (CE4)1 (CE5)1 (CF3)5 (CF4)1 (FO6)66,75,109,116 (FO7)90 (FP6)9,21,24,97,109,131,138 (FQ3)58 (FQ4)2 (TG5)114	67 92 92C 110 110C 110OX	1112 1137	910 RBR TOP RBRI RBRIE	11-28	608	HM	
3.11.6	4107a	(FO6)19,62,92	92 110	871		15-16	24	HM	
3.11.6	4189	(FP6)34	92		910	13	45	HM	
3.11.6	4687	(FP6)34	105C			12	50	HM	
3.11.6	+4689	(FP6)131,143,188 (FO7)90	110 110C		910	11-15	214	HM	
3.11.6	4696	(FP6)134/ 135,156	94 110		H820ER	14-15	55	HM	
3.11.6	4700	(FO7)90 (FP6)138,170	105L,110		CCR	11-18	47	HM	
3.11.6	+4710	(FP6)34,96,131	105C	871		12.5 14	R 16 B 100	HM	
3.11.6	4711	(FP6)143,154,155,169 (JG1)-	92 110	SQ 871	CRR	7-23	165	HM	
3.11.6	4722	(FP6)143	105L	871 x 2	CRR	16x18	100	HM	
3.11.6	4723	(FP6)143,156	110	basket impr. under slip	910 820E	14-18	101	HM	
3.11.6	+4729	(FP6)34,60,128,143,151,159, 188	110 110F		910	13-18	127	HM	
3.11.6	4730	(FP6)109,143,170	110		CRR	13-15	23	HM	

Fig. no.	Type	Provenance	Fabric	Dec.	Surface treatment	Dia.	%	Man.	Comments
3.11.6	4737	(FP6)96,143 (FP7)11	110	871 x 2	CRR	12x14 18	107	HM	open type
3.11.7	143	(AB4)31 (AB5)5 (AC6)18 (BD3)33 (BD4)16 (BE1)73 (BE2)1,145 (BE3)10,18,27 (BE4)9 (BF1)4,27,30 (CE4)1,47 (CF3)1,22,41 (CF4)111 (TG5)1,6 (ZH5)82	1 20 25 48		825EW	-	6340	HM	
3.11.7	2052	(AB5)80 (BD2)29 (BE3)1 (BF3)9	66 67 92			14-21	136	WM	
3.11.7	2280	(BE3)57,106 (BF1)56 (BF2)33 (CE4)2 (CE5)4,6,86 (CF4)1,10,13,37,50,56,59, 65,96,112,113,161 (CF5)1 (HA2)12 - (JG2)1	25			-	3350	HM	
3.11.7	2311	(AD5)149 (BE3)10,20 (BF3)38 (CF4)75 (FR3)14	1 25 110			9	415	HM	
3.11.7	2322	(BE4)9 (BF1)16	67			13	73	WM	
3.11.7	2324	(BE3)18 (BE4)9	1 20		820EBR	7-8	46	HM SW	(BE3) BC
3.11.7	2426	(AB4)10 (AB5)86 (BE4)19 (BF1)4	2 25 25L			-	545	HM	
3.11.7	2482	(AB4)11 (BE3)16 (BE3)56 (CE4)48	25			7-8	64 B 100	HM	
3.11.7	2596	(AB4)28 (AB5)58 (AD5)1	92 93			13 B 15	96 R 175 B	WM	
3.11.7	+2601	(AB5)58	67		825EW,R,Y dribbles	22	10	WM	
3.11.7	2630	(AB4)7,10,11 (AB5)66 (FP6)9	25 25L 92		825EW	6-7	344	HM	
3.11.7	2633	(AB4)11,23 (AB5)64 (AD5)1,207 (CE4)47,98 (CE5)1 (CF4)18,100,101,133,145 (FQ3)42 (FQ4)3 (FT3)1 (TG5)12 (ZH5)85	25 25L		820ECR 825EW	-	3130	HM	
3.11.7	2655	(AB4)10,19,23,32 (AB5)40,207 (AC5)37,57 (BD2)71 (GD3)92 gr. 95 (HA2)79 gr. 197,227 gr. 207 (TG5)1,29-74,29-102,65- 84,76,86-94,89	25 25L 71		825EW	-	4935	HM	3 unfired
3.11.7	2693	(AB4)11,22,23,28,32,33 (AB5)20,40 (AD5)1 (BD2)26 (BD4)8 (BE1)61 (BE3)56 (CE4)2,4,23,42 (CF3)41 (CF4)17,67,75, 92,96,107,109,113,117, 133,139,173 (CF5)5 (GD3)1 (TG5)1,6,7,29-102,30,35,77- 84,90,94,97,102,105	1 25 25L 92 92C 94		825EW	6-14	988 R 1600 B	HM	1 unfired mould groove
3.11.7	2721	(BE1)49	25		820IW 825E	6	55	WM	
3.11.7	2782	(BD3)33	67			11 R 12 B	17 R 30 B	WM	
3.11.7	3032	(CF4)172 (CF5)4 (TG5)1 (ZH5)17	25				300	HM	
3.11.7	3281	(AD5)161a	71			8	35	HM	
3.11.7	3282	(AD5)59,161a,167	92			9-9.5	167	WM	
3.11.7	3610	(TG5)16	-			8	-	HM	
3.11.7	4038	(TG5)87	92			14	19	WM	
3.11.7	4320	1098 4 (CF3)8 (TG5)1	25			6-6.5	245	HM	mould groove
3.11.7	4402	(CF3)8	92			-	100	HM	leg??
3.11.7	4497	(CE4)48,85 (CF4)99,133	25			-	600	HM	

Fig. no.	Type	Provenance	Fabric	Dec.	Surface treatment	Dia.	%	Man.	Comments
3.11.7	+4654	(JG1)32 gr. 12	94		820EW(P)	8.5 /17.3	60/ 100	WM	
3.11.7	+4661	(FP6)188	94	194g 871 x 2		25	100	WM	complete
3.11.7	4815	(CF4)13	67	871?	820IY	-	-	WM	
3.11.8	2605	(AB5)20 (CE4)37	1 92C			11x15.5	96	HM WM	
3.11.8	2622	1084 7	1			8.3x6.4	100	HM	
3.11.8	2631	(AB5)35,66	2 69		820ER 825EP RBR	17	107	HM WM	
3.11.8	2731	(BD3)8 (BE2)151	22 92			17x15	-	WM	
3.11.8	2763	(BF2)51	34		825ER	-	-	WM	
3.11.8	2889	(BD2)81	92			6	-	HM	
3.11.8	2985	(AB4)23	65		820EW	-	-	WM	
3.11.8	+3021	(ZH5)40,45	80			21x15	20+	WM	
3.11.8	+3124	(JC3)11 (TG5)1,73,94 (ZH5)15,37,38,44	2 67 92 94 110		910	26	135	HM	
3.11.8	3319	(AD5)87	92		RBRIE	-	-	HM	
3.11.8	3760	(AD5)239	94		825EIW	-	-	WM	
3.11.8	4302	(TG5)75	94	1176 871 x 2	820EW	2	25	WM	lamp?
3.11.8	4408	(CF4)50	92			5	90	HM	
3.11.8	+4449	(JC3)2	110			16.8	95	HM	nearly complete
3.11.8	4556	(CF3)128	92			3	100	HM	lamp
3.11.8	4811	R18 LOCUS NO	92			5x6	100	HM	
3.11.8	4827	(JE2)4	114			-	-	WM	abraded
3.11.9	2136	(AB5)1,14 (BE3)50 (BF1)56 (CF4)115	8 69 92			7-20	175	HM WM	(CF4) complete
3.11.9	2180	(BE3)57	65			6	25	WM	
3.11.9	2185	(BF3)50 (CE4)19	1 110			6-30	27	HM	
3.11.9	2232	(AB4)28 (BD2)24,94 (BE2)10 (CF3)1 (CF4)62 (JD2)18	2 92 92F 94	2 holes		3-11	131	HM WM	(BD2) trace upper hole too
3.11.9	2260	(BE3)78 (CF3)2	92	851?		4-5	65	HM	
3.11.9	2268	(BE3)37,78	69 76			7.3-9	58	HM	
3.11.9	2282	(BE3)106 (TG5)5/4	25 32			7-8	34	HM	
3.11.9	2411	(BE2)21,43	69 92			5.5-6	200	HM WM	
3.11.9	2480	(BE2)103 (BE3)16 (FP6)9	67 92 92F			5-11	95	HM WM	
3.11.9	2517	(BE2)50	11			13	16	HM	
3.11.9	2619	(AB5)58	94			2.5	95	HM	
3.11.9	2659	(AB4)7,33 (BE1)1,49,53	11 40 92 94		825ER 825IR	12-14	98	HM WM	
3.11.9	2680	(AB4)10 (BE3)18	1 92			10-13	54	HM	
3.11.9	2733	(BF1)2 (CF3)1 (TG5)6	1 92			4-8	123	HM	B hole
3.11.9	2751	(BF1)57	94			3	100	WM	B hole
3.11.9	2775	(BD4)17	92/ 22			3.4	100	HM	
3.11.9	2788	(BD2)28	92			7	100	HM	
3.11.9	2808	(BD2)71	92			4.5	100	HM	
3.11.9	2814	(AB5)59 (AB6)16	92			7.6	100	WM	999
3.11.9	2850	1084 7 (CF4)1	88 92			11	7	HM WM	
3.11.9	2850a	1084 7	88		825ER	7	15	WM	
3.11.9	2871	(AB5)207	65			3.5	75	WM	
3.11.9	3083	(CF4)17 (ZH5)40	94F			8	42	WM	
3.11.9	3141	(ZH5)53	92			-	-	HM	lamp use?
3.11.9	3594	(TG5)22	-			5.5	-	HM	
3.11.9	3827	(AD5)289 (BE3)56,59,118	25 69 92 110			5-12	67	HM	
3.11.9	+4150	(FO6)54	23			-	100	WM	complete
3.11.9	4254	(TG5)79	94F			3	20	WM	

Fig. no.	Type	Provenance	Fabric	Dec.	Surface treatment	Dia.	%	Man.	Comments
3.11.9	4276	(TG5)77,113	71 92			4-16	17	HM	1 cruc? 1 UF
3.11.9	4299	(TG5)65	94F			4	16	WM	lamp use?
3.11.9	4429	(TG5)1	25			8	23	HM	
3.11.9	4492	(CF4)101,134	92 110		820IR 822R	7.5-9	34	HM	
3.11.9	4518	(CF3)31,49	92		R810I	3-7	125	HM	
3.11.9	4596	(CF4)164	92	851 x 2		4	100	HM	complete
3.11.9	4605	(TG5)7	94	1248		12	7	HM	
3.11.9	4613	(CF4)96 (TG5)5/4	92 110			4	200	HM	
3.11.9	4704	(BF3)58	92			4	85	HM	
3.11.9	4724	(BE2)10 (CF3)2	25 92			3-5	107	HM	
3.11.9	4725	(BE3)20	71			5	21	HM	
3.11.9	4726	(BE3)18	92			3	100	HM	unfired
3.11.9	4731	(FQ3)41	92			4	100	HM	crucible
3.11.9	4732	(TG5)29	92			6	75	HM	unfired
3.11.9	4806	(FZ1)12	25			-	-	HM	
3.11.9	+4834	(FQ3)31	92	1287		8.2	100	HM	unfired
3.11.9	4835	(FQ3)31	92	851 x 4		1.3	100	HM	
3.11.10	2187	(BF3)50	92			-	100	HM	foot of -?
3.11.10	2262	(AB5)89,220 (BE1)63 (BE3)26,27 (BE4)13 (FP6)156 (TG5)35	67 69 92 110		820ER 910	9-26	68	HM WM	
3.11.10	2354	(BE3)10	25	1294		19	13	HM	
3.11.10	2441	(AC5)55 (AD5)272	92			16-17	13	HM WM	
3.11.10	2620	(BE1)1	1	ram head		7	20	HM	
3.11.10	2672	(AB4)10 (CE5)1	94F 110		822W	9-12	65	HM WM	hole 4.5mm
3.11.10	2710	(AB5)89,229 (AC6)12	1	1083 871	820ER 825ER	6	30	HM WM	898?
3.11.10	2952	(AB4)23	92		dribble R	5	75	WM	
3.11.10	3034	(FP7)2 (ZH5)20	110			15-20	7	HM	
3.11.10	3277	(AC5)49 (AD5)31 (TG5)29	67 92		820ER	-	-	WM	
3.11.10	3429	(AD6)14 (CF4)51	92 110		822R RBRI	8.5	102	HM WM	(AD6) complete
3.11.10	+3486	(AD6)16	110			20	9	HM	999 3727x
3.11.10	3720	(AD5)241	67			-	-	WM	28 x 26mm
3.11.10	3727	(AD6)16	92			-	-	HM	999 3486x
3.11.10	3728	(AD5)217	92	bird	825ER partial	-	-	HM	
3.11.10	3764	(AB4)28 (AC5)77 (TG5)5/4	92 94	crocodile	822W 825ER	10	17	HM WM	crocodile(?) appliqué
3.11.10	3769	(AC5)79	92F		825ER	-	-	HM	
3.11.10	3770	(AC5)79	92F	head	825ER	-	-	HM	
3.11.10	3801	(AD5)262	67	bird	825ER	-	-	HM	
3.11.10	3874	(AD5)312	92			-	-	HM	
3.11.10	4108	(FO6)47	110		CRR	8	54	HM	
3.11.10	4190	(FP6)37	92		820ER			HM	
3.11.10	4319	(TG5)1	132			9	21	WM	Aswani
3.11.10	4532	(CE4)11	110		910	18	6	HM	
3.11.10	4550	(JF2)51 gr. 55	69		H820ER 825IP	15	70	WM	
3.11.10	4618	(TG5)4	92			-	-	HM	
3.11.10	4643	(FP6)94	92			17	6	SW	
3.11.10	4705	(AB4)23,28 (BE3)18	92		825EIR CRR	8-9	145	HM	
3.11.10	4727	(BE3)10	92 UF					HM	
3.11.10	4770	(JD2)51 gr. 40	92					HM	leg?
3.11.11	2063	(AB5)40 (BD2)71 (BF2)39	65 92		H822R	6	80+	WM	
3.11.11	2437	(BE3)27	67	2 holes		-	-	HM	
3.11.11	2446	(BE3)10	1			-	-	HM	898 3426x
3.11.11	2592	(AB5)68	1			-	-	WM	

Fig. no.	Type	Provenance	Fabric	Dec.	Surface treatment	Dia.	%	Man.	Comments
3.11.11	3320	(AD5)87	71	hole 22mm		50	3	SW	
3.11.11	3336	(AD5)129	71			-	-	HM	CB
3.11.11	3426	(BE3)16,27	91C			55?	5	HM	898 2446x
3.11.11	3542	(JE3)1 (ZH5) locus ^a	105	871 x 4 pre-firing				HM	very abraded
3.11.11	3766	(AC5)77	110		820EBR	-	-	HM	
3.11.11	4161	(FO6)116	71		825EICR	-	-	HM	
3.11.11	4300	(TG5)65	92C			-	-	HM	
3.11.11	4325	(TG5)1	60			-	-	HM	
3.11.11	4361	(CF4)1	2	1198		-	-	HM	
3.11.11	4426	(TG5)6	94			-	-	HM	
3.11.11	4447	(JG1)20	92C					HM	
3.11.11	4448	(JG2)1	25	1119		-	-	HM	

^a 19° 07.461' N, 30° 29.948' E

3.12. Bases and handles

This section contains the bases and handles that do not clearly relate to a particular form. Rounded bases are by far the most common, but are often not distinct amongst the excavated material and thus do not figure correctly in the statistics; flat and ring foot bases were easy to distinguish and all those found are recorded here, but that is not to say that they are prevalent. Neither in Napatan nor Meroitic contexts is one form used exclusively. However, the ring foot appears to be more common in the later period.

The harder the surface a vessel is placed on (a hard floor, a *mastaba*, a table (?) rather than on soft sand) the more unstable a round-based vessel is likely to be, so that the flat or ring foot may be indicative of the environment a vessel was designed to be used in. Conversely, it is easier to set a round-bottomed pot upright in soft sand than one with a flat base. In the case of cooking pots, usually set into the fire directly, a round base is easy to stabilise; but in the case of the beakers, or cups for drinking, the ability to put the vessel down has implications for social etiquette. Pot stands (3.11.7) effectively have the role of a ring-foot, but very few have been recovered; they do not appear to have been part of the normal household equipment, and occur in Meroitic contexts as well as Napatan (e.g. +4654x).

A total of 115 ring-footed bases were recorded, but as it has not been possible to count the surviving percentage of the more common rounded bases, we can only say that ring-footed bases are much rarer. Flat bases usually mostly are found on the offering dishes (3.10.5-3.10.6) and some beakers/beer bottles (3.10.4), and have mostly been recorded together with the complete profile form number; in only a few instances (13) the flat bases cannot be tied to a particular form.

Handles feature relatively rarely in the form repertoire, figuring principally as indicators of the presence of amphorae. Very few jugs occur in the areas excavated. A series of bosses and/or lugs (of related functional use, but also decorative) are illustrated in Figures 4.1 and 4.2.

Evidently all the handles are handmade; in the table HM/WM refers to how the vessel it belonged to was made, if known (some handles are found broken clean off the wall of the pot).

3.12.1 Miscellaneous rounded bases of bowls, jars and possibly beakers

2250x: Imported (sample (AB6)8, Fabric 96); (BD2)94 may belong to the same form as 2906x (3.2.11).

3.12.2 Amphora bases, rounded bases, omphalos and flat bases

3099x: Vincentelli 2001, fig. 5.e, 25th Dynasty.

3190x: For a jar/amphora base with a similar 'construction', Vincentelli 2006, fig. 2.96 604, Hillat el-Arab tomb ARA 19. The date given is Napatan, and Vila (1980) publishes similar storage jars, but at Kawa this type is rare.

4792x: Beg.W.145 (45-55? 43 BC-AD 115) fig. C26, 222-312. Garcia Guinea and Teixidor 1965, 104, fig. 32.5, pl. XXXIVa, dated by analogy to the 1st or 2nd century AD (Nellulah). Also several jars with similar bases at Karanog

(Woolley and Randall-MacIver 1910, IV, pls 41-100 and 105, forms F xxvii-xxix). NB This form, given its fragmentary state could possibly be the side of a pilgrim flask, but the white slip on the interior suggests that it is more likely to be a base.

3.12.3 Ring-footed bases

All wheel-made except for 4587x. All of these appear to belong to deep bowls or closed forms, rather than dishes.

2029xb: Bar.1 (44.I, 56-43 BC) fig. 69, 16-2-284.

2231x: Bar.1 (44.I, 56-43 BC) 16-2-291 fig. 69, but wall more curving.

2331x: Bar.6 (44, 56-43 BC) 16-2-363 fig. 66.

2447x: Bar.6 (44, 56-43 BC) 16-2-360 fig. 66.

2650x: This kind of ring-footed base, where the round base of the pot protrudes below the ring has a parallel in Vincentelli 2006, fig. 2.75 466 (Napatan date).

3061x: Beg.W.353 (undated) fig. M7, 23-2-152.

3387x: Were it not for being wheel-made, this base is similar to the coarse pots in section 8.3, more so than a beaker in section 10.1.

4592x: The broken edge at the centre of the base has been smoothed, as if the vessel had been used inverted as a pigeon pot (see 3.4.5).

3.12.4 Miscellaneous handles

Belonging to wheel-made vessels, especially amphorae.

+2530x: Belonging to amphorae(?) of unknown type, both the example from (CE4)20 (one end smoothed) and (FQ3)41 (both ends smoothed), had been reshaped for subsequent use (see Welsby and Taylor forth., cat. nos F-516 & F-542).

4318x: Note similar form, with rim, 2491x (3.2.11).

4323x: Aswani fabric (and production)?

3.12.5 Coarseware handles, some from handmade vessels, as well as bosses and lugs

3389x: Near the join to the vessel body there is an appliqué encircling the handle; it is difficult what it is intended to represent, a snake, or the tail of an animal? No practical reason for it comes to mind, and neither does a parallel.

4555x: Painted handles with decoration are a Hellenistic characteristic: Török 1997, II, fig. 69, 98-4 (late 2nd to early 1st centuries BC, and also similar to fig. 134, x-75; Bar.9 (47, 20-10 BC) fig. 75,16-2-394b.

4617x: Handle with painted decoration, a Meroitic characteristic (cf. Bąkowska 2010, fig. 7C.35).

4699x: The type of join to the body of the vessel is similar to the handle(s) of 3558x (3.2.10). If dating by the parallel, this would suggest a mid Meroitic date, but given that 4699x was found within the Napatan deposits of Building F1, it is probable that this type of handle characteristic is not limited to the later Kushite period.

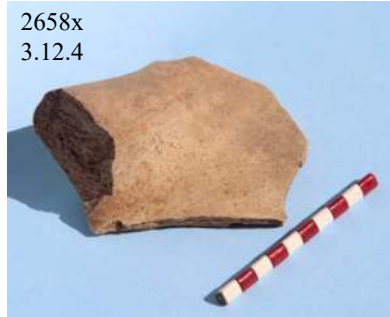

Plate 3.12.1. Miscellaneous handles of wheel-made jugs or amphorae.



Figure 3.12.1. Miscellaneous rounded bases (scale 1:4).

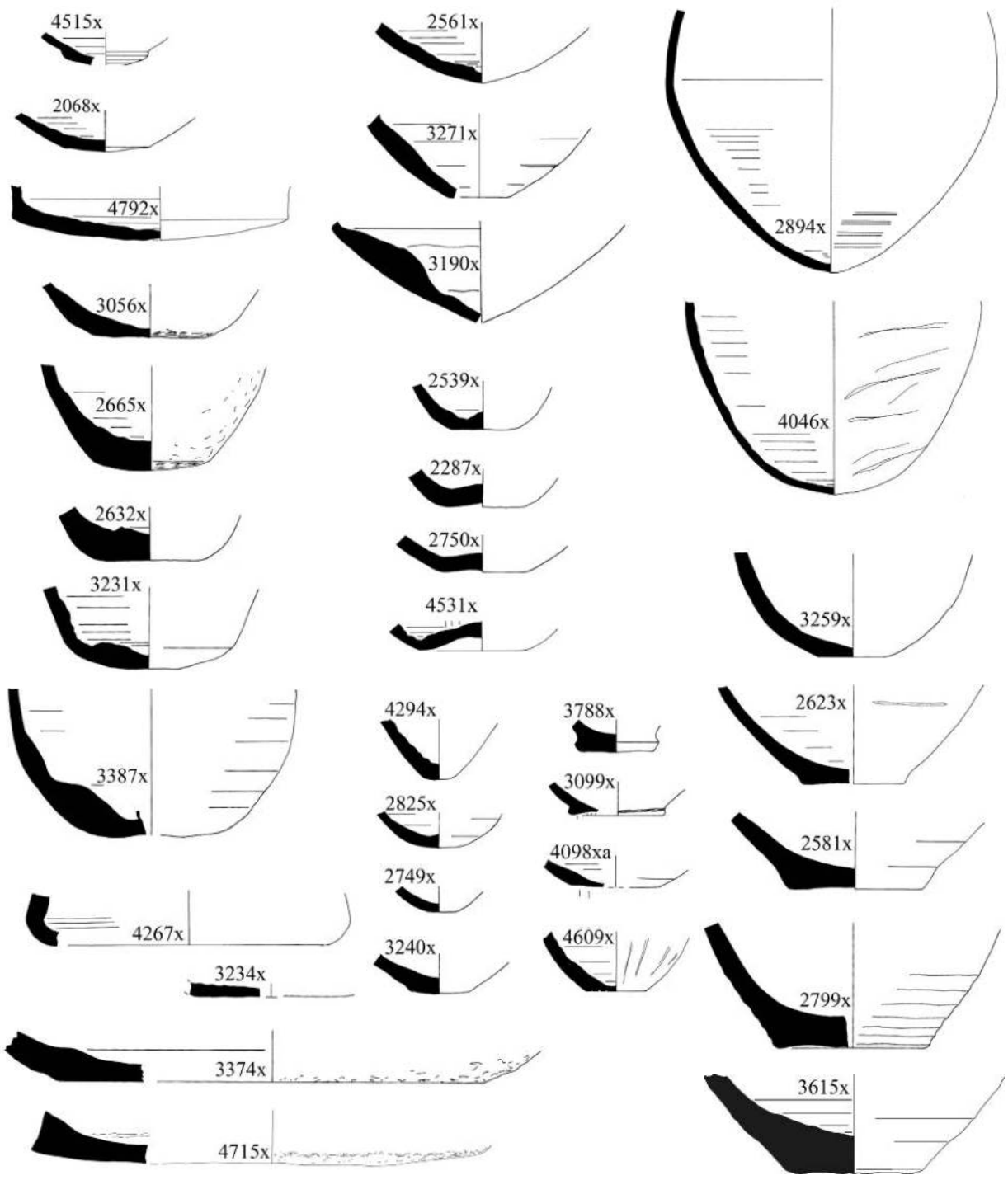

Figure 3.12.2. Amphora bases, rounded bases, omphalos and flat bases (scale 1:4).

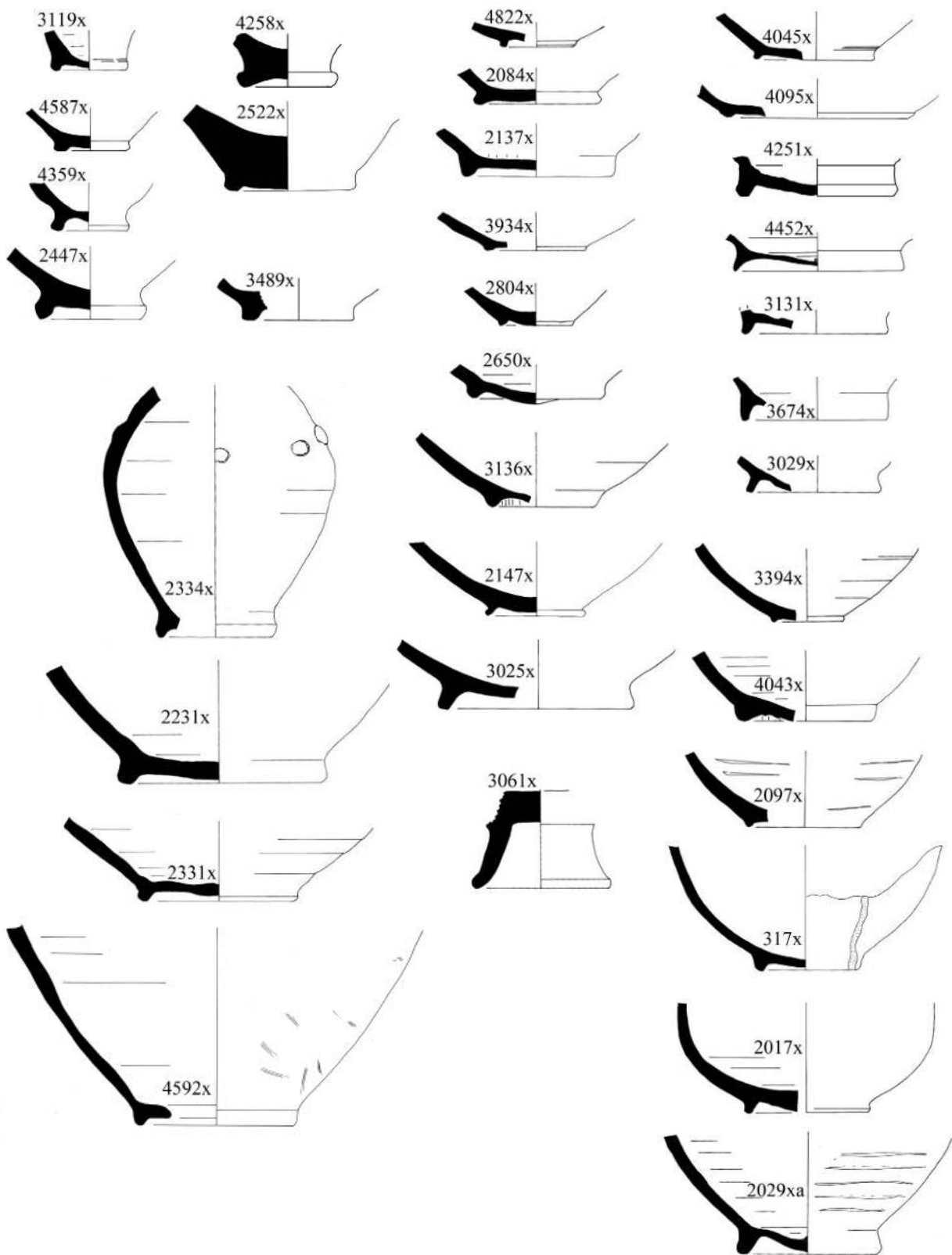

Figure 3.12.3. Ring-footed bases (scale 1:4).



Figure 3.12.4. Miscellaneous handles, especially of amphorae or jugs/flacons (scale 1:4).

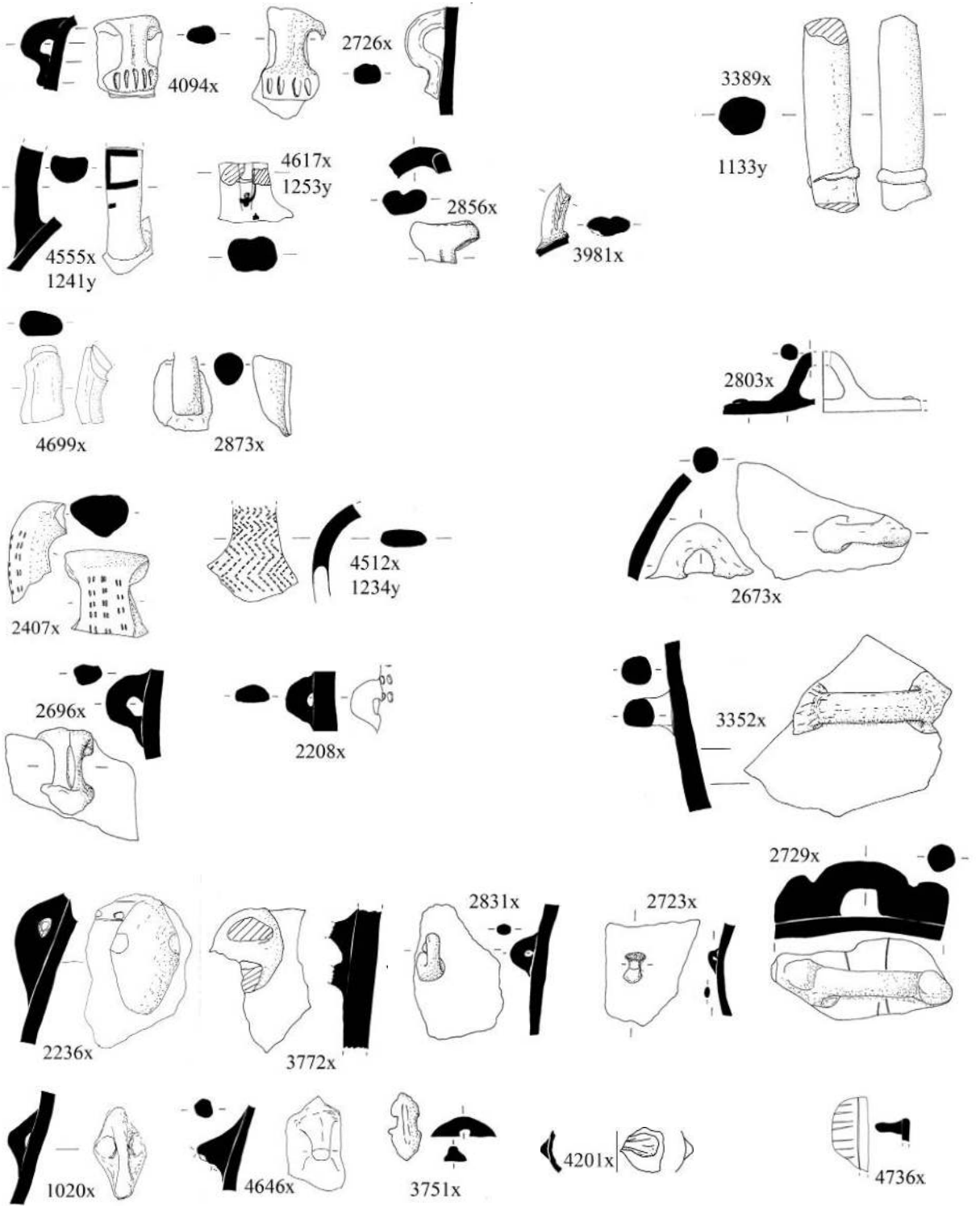

Figure 3.12.5. Miscellaneous handles, especially but not exclusively, from handmade vessels; lugs/bosses (scale 1:4).

TABLE 3.12. BASES AND HANDLES.

Fig. no.	Type	Provenience	Fabric	Dec.	Surface treatment	Dia.	%	Man.	Comments
3.12.1	2036	(AB4)4,7,10,11,15,23,66 (AB5)1,25,32,65,66,67, 68,91, 94,230 (AC5)1,13,23 (AC6)1,23 (AD5)1 (BD2)45 (BE2)48,105,114 (BF3)8 (CF4)1 (FO6)92 (TG5)76	1 25 25L 66 67 68 69 80 83 92 93 94		820ER H820ER V820ER 820IR 822R	-	2142	WM	tool marks on B
3.12.1	2070	(AB4)7,10,20,23 (AB5)25,32 (BD4)8 (BE1)80 (BE2)14 (BF1)9,56 (BF3)8 (CF4)139,181 (JE3)5 (ZH5)55	11 29 65 67 92 93 94 95 110	8	820ER H820ER 822R	-	1132	HM WM	
3.12.1	2250	(AB4)7,10,15 (AB6)8 (AC5)12 (BD2)24,94 (BD3)9,28 (BE1)85 (BE2)158 (BE3)16,78 (BF1)4,53,57 (TG5)76	25 53 67 69 77 80 88 92 94 96		820EO 820ER 820EW 825ER 825IR	-	1240	WM	(BD2) 898 R 2906x (3.2.1)?
3.12.1	2400	(AB4)6,23 (AB5)68,80 (AC5)67 (AD5)22,56 (BE3)16 (BE4)60 (CF3)13	1 67 69 92 110	8	802	-	350	HM WM	
3.12.1	2519	(AB4)14 (AD5)107 (BD2)100 (BE1)1,51 (HA2)45 -	26 53 67 88 92 94		820ER 822R	2.7-3.4	275	HM WM	
3.12.1	2524	(BE2)48	84		820EW	4.5	42	WM	
3.12.1	2602	(AB4)23 (AB5)41A,58,66 (AD5)7	67 66 69 92		825ER 825EW	-	385	WM	
3.12.1	2694	(AB4)11,20,23,28,31,33 (AC5)37,53 (AD5)4,20,56,67,69,87,126,242, 246 (BE1)78 (BF1)57 (FP6)32 (FR3)2 (FT3)1 (HA2)91 gr. 90 (TG5)29,75 (ZH5)37	65 67 69 80 92 92F 93 94 113		820ER H820ER 820EW 822R 822CR 825ER	-	2963	WM	
3.12.1	2877	(AB4)20,23 (AB5)220 (AD5)28,132	69 80 92		820ER V820ER	-	490	WM	
3.12.1	2878	(AB5)223 (AD5)34 (BD2)100 (JG2)180 gr. 150	39 92F 94	61g	820ER	-	180	WM	
3.12.1	2957	(AB4)23	6		804E	13	100	WM	
3.12.1	2991	(AB4)23 (AD5)112 (JE3)2	65 94F 110			-	60	WM	
3.12.1	3006	(AB5)233	92		825ER	-	100	WM	
3.12.1	3129	(ZH5)44	67		lug?	42	-	HM	
3.12.1	3194	(AC5)23 (AD5)12,20,87 (CE5)1	67 92 94		825EW	-	270	WM	
3.12.1	3711	(AD5)227	94			-	-	WM	
3.12.1	3775	(AD5)246	110		820ER	-	100	HM	
3.12.1	3787	(AC5)73 (FP6)89 (TG5)112	67 94		H820ER	14.5	85	WM	
3.12.1	3835	(AD5)288	4			5	75	WM	
3.12.1	3960	(FQ3)31	92			-	-	WM	
3.12.1	3974	(FQ4)106	110			-	-	HM	
3.12.1	4798	(GD3)83c gr. 38	94F			-	70	WM	
3.12.2	2068	(AB4)10,23,28,31,33 (AB5)43,59,68,230,233,292 (AB6)1 (AC5)39,51 (AC6)30 (BD2)23,24,28, 61,65,71 (AD5)59 (BD3)12,14,16 (BE1)44,49,51 (BE2)67 (BF1)6 (BF2)32 (FT3)17 (TG5)1 (ZH5)85	13 65 66 67 69 80 83 92 92L 93 94		820EO 820ER V820ER 820EW 820EP/ 820EW 820IP 820IR 822R H822R 822W 825ER	3-10	2159	WM	
3.12.2	2287	(BE2)73 (BE3)56	61 94		820ER 822R	5.5	110	HM	
3.12.2	2539	(BE2)67	67		800E	4.3	100	WM	

Fig. no.	Type	Provenance	Fabric	Dec.	Surface treatment	Dia.	%	Man.	Comments
3.12.2	2561	(533)14 (AB4)1,6,10,11,23,27,33 (AB5)29,32,40,41,58,66,68,86,92 (AB6)9,27 (AC5)1,3,7,73,134,144 (AC6)18,20 (AD5)1,28,34,61,139,167,190,214,226,258,268,272 (BC2)2 (BE1)18 (FP6)89 (FQ4)2,124 (FR4)1 (JE3)1,44 - (HA2)68 gr. 204 (TG5)74	1 9 65 65L 67 69 80 81 92 93 94 98 102 105 130	850 x 1	820EGR 820ER V820ER 820EW 820IGR 825ER 825IR 825EW ribbed	-	5050	WM	
3.12.2	2581	(AB4)10 (AB5)14 (BE1)73 (BF1)73 (TG5)29	25 67 71 92			8-11	334	HM WM	
3.12.2	2623	(AB5)66 (AD5)167 (JD2)43 gr. 40	67 69 92		820ECR	6-14	135	HM WM	
3.12.2	2632	(AB4)10 (AB5)67	92			6-7	58	WM	
3.12.2	2665	(AB4)11,23 (AB5)207,233 (AB6)8 (AD5)87 (BD2)50, 71,99 (BE2)88 (FT3)1	25 67 80 92 94		V820ER	-	1640	WM	
3.12.2	2749	(BE3)78 (BF1)53 (BF3)8 (TG5)86-99	1 14 92 94		820EO	2.5-9	195	WM	
3.12.2	2750	(BE3)146 (BF1)2,5,7	2 45 67		822R V822R	5.5-6	245	HM	
3.12.2	2799	(AB4)23 (AD5)1 (BD2)70	67 92			5.5-11	185	WM	
3.12.2	2825	(AC6)22 (CF4)162 (TG5)46	67 92		820ER	4	122	HM WM	
3.12.2	2894	(AC5)64 (AD5)112 (BD2)100	23 67 86		825EW	-	210	WM	
3.12.2	3056	(AC5)23	65 92			5.5-7.5	200	WM	
3.12.2	3099	(CE4)1 (ZH5)15	80 92			2.5-6	73	WM	reused as dish?
3.12.2	3190	(FT3)44	69					WM	
3.12.2	3231	(AD5)67	89			10	50	WM	
3.12.2	3234	(AD5)67 (FO6)52	69 113			1.5	27	WM	B hole
3.12.2	3240	(AC5)51 (AD5)28,84,87 (FQ4)1 (TG5)22	67 92 92C 94		822R 825EIBG	4-8	265	HM WM	
3.12.2	3259	(AC5)51 (AD5)97 (TG5)4,5/4,29-74	67 92 94			4-12	172	WM	
3.12.2	3271	(AC5)37 (AD5)278	67 129		H822W	-	22	WM	
3.12.2	3374	(AC5)39 (CF4)109	67 110			29	12	HM WM	
3.12.2	3387	(AD5)112	86		coarse 820IP	-	100	WM	pre-firing hole B
3.12.2	3615	(HA2)158 gr. 116	94			-	-	WM	Napatan?
3.12.2	3788	(AC5)73 (TG5)1,74	92	string cut		5-6	220	WM	
3.12.2	4046	(GD3)42 gr. 41 (TG5)91	94		820ER	-	130	WM	
3.12.2	4098A	(JF2)52 gr. 55 (TG5)103	26			5	25	WM	
3.12.2	4267	(TG5)132	92			22	10	HM	
3.12.2	4294	(TG5)65	94		820ER 820IBLH H820ER	1.5	100	WM	
3.12.2	4515	(CE4)71	26			6	29	WM	
3.12.2	4531	(CF4)109	92		820ECR	8	100	WM	
3.12.2	4609	(BF3)8 (TG5)86-89	65 94		820EW 820ER/ 825ER	4-6	42	WM	

Fig. no.	Type	Provenance	Fabric	Dec.	Surface treatment	Dia.	%	Man.	Comments
3.12.2	4715	(FO)7/73	92C			25	9	HM	
3.12.2	4792	(GD3)52 gr. 51	105		820IW	18	32	WM	
3.12.3	317	(AB4)23 (AD5)67,113 (BD2)28,45 (BD3)14 (BE2)10,17,32 (BE3)10 (BF2)31,33 (BF3)8,9,38,56 (CF3)1 (CF5)1 (TG5)91 (ZH5)37	2 8 9 17 25 31 32 33 38 56 67 69 92 93 94 115	dribble	820EO 820ER 820IW 822W 825ER	7-12	587	WM	(BE2)17 999 (BE2)10 (BE3)10
3.12.3	2017	(AB4)10,23,31 (BD2)24,50,101 (BE2)1,18,73,(BE3)78,146 (BF1)4,6,56,61 (BF2)1,31,37 (BF3)17 (TG5)91	65 67 76 80 92 93 94		820EO 820IR 820IW 822R 822Y 830EP	6,4-13	861	WM	
3.12.3	2029b	(AB4)23 (AB5)14 (AD5)0,87 (BC4)1,2 (BD2)26,28,100 (BF1)57 (BF3)9,38,50,59 (CF4)18, 50 (CF5)4 (TG5)4,65,74	1 65 67 69 80 92 94 94F 97		805EI H820ER 820EW 820IR 822R 822W 825EIW	3-15	850	WM	
3.12.3	2084	(AB4)23,31 (AB5)1 (BD4)1 (BD2)24,50 (BE3)10 (BF2)47 (CF3)49 (TG5)6,65	13 67 69 92 94		820IR 822R	6-10	509	WM	
3.12.3	2097	(AB4)23 (AC5)37 (AD5)134 (BF1)6,56 (BF3)56 (FO6)107 (TG5)74	67 92 93 94		820IR 822R	5,2-11	378	WM	
3.12.3	2137	(AB4)10,23,31,33 (AB5)32,67 (AB6)1 (AC5)55 (BC4)1 (BE1)7,18,41 (BE2)1,48,103,128 (BE3)16,55,146 (BF1)6,16,28,56 (CF3)8 (FR3)1 (TG5)5/4,53,74	65 67 69 80 92 93 94		820IR 820ER 820EP 820ICR 820IW 822R 825ER	5-13	943	WM	
3.12.3	2147	(AB4)23 (AB5)14 (BC4)2 (BD2)24,29 (BD3)33 (BE2)48,105 (BF2)37 (AB4)32 (BD2)26,28,50 (BD3)9,33,46 (BD4)16 (BE1)9,2,6,7,3 (BE2)12,38,100 (BE3)16 (BE4)16 (CE4)1 (CF4)1 (TG5)77 (561)1 (AD5)112 (BF1)35	65 67 92 94		820IR 822CR H822R	7-9	412	WM	
3.12.3	2231	(BE2)110,147	12 25 65 67 69 76 80 92 94		820ER 820IW 822R 825EP	7-21	645	WM	
3.12.3	2331	(BE2)71 (CF4)155	94	lug	820EW H820IW 820ER 820IR	10-11	116	WM	
3.12.3	2334	(BF1)56	13 56			9	32	WM	
3.12.3	2447	(AB4)6,7	13 94			6-8,5	80	WM	
3.12.3	2522		67			9,5	100	WM	898 2649x (4.3)?
3.12.3	2650		65 93		825EIW	9,5-10	140	WM	
3.12.3	2804	(AB4)23,31,33 (AC5)51 (AD5)7,87 (BC4)1 (CF4)1 (FQ4)2	65 80 92 113 115		820IW 825EIP	4-7,5	535	WM	
3.12.3	3025	(AC5)51 (TG5)74,91 (ZH5)9	80 94		825IP 820IW	9-13	117	WM	
3.12.3	3029	(TG5)1 (ZH5)11,37	94 95 100			8-9	43	WM	
3.12.3	3061	(AC5)24	1			10	70	WM	
3.12.3	3119	(CE4)2 (CF4)1 (ZH5)37	80 92 94		822O	4-5	235	WM	worm edges, reuse?
3.12.3	3131	(FR4)1 (TG5)74 (ZH5)60	65 92 94			8-10	31	WM	
3.12.3	3136	(CE4)1 (ZH5)85	67 92		822R	7-8	65	WM	
3.12.3	3394	(AD5)112	65		820IW	5	45	WM	
3.12.3	3489	(AD5)198	94			8	12	WM	
3.12.3	3674	(TG5)5/4,64	92		822W	10	17	WM	
3.12.3	3934	(CE4)1 (CE5)1 (FO6)15 (FQ3)40 (HA2)79 gr. 188	67 69 84 94 99		820ER 820EBL 825IBL	6-9	88	WM	

Fig. no.	Type	Provenance	Fabric	Dec.	Surface treatment	Dia.	%	Man.	Comments
3.12.3	4043	(CF4)10 (CF5)1 (TG5)73,91	67 92F 94		820EW 820ER 820IW 825ER	10-11	74	WM	
3.12.3	4045	(BF2)31 (BF3)8 (TG5)5/4,73,91	25 65 67 80 83 92 94		820IW	7-10	274	WM	
3.12.3	4095	(CF4)62 (TG5)12,95	94			6-13	25	WM	
3.12.3	4251	(TG5)112	94			11	35	WM	
3.12.3	4258	(TG5)104	94			7	26	WM	
3.12.3	4359	(CF3)1,2 (CF4)1,10	67 92		825EIR	5-7	260	WM	
3.12.3	4452	(CE4)23	114			3.12.5	72	WM	
3.12.3	4587	(CF4)112	92			5	100	WM	
3.12.3	4592	(CF4)109	94		820EY	11	70	WM	reused as oven?
3.12.3	4822	(JG1)35 gr. 31	80		820IW 825ECR	5	18	WM	
3.12.4	2028	(AB4)7,10,31 (AB5)207, 215,220 (AC5)23,37,78 (AC6)12,23 (BC2)3 (BD2)28,29,45 (BD3)16 (BD4)8 (BE1)26 (BE2)51, 70,87,103,110,116 (BE3)37,57,71,106 (BE4)14 (BF1)44,53,56, 57,61 (BF2)1,31,47 (BF3)9,17 (FO6)91 (FR3)0 (TG5)37,73,91,109,112	10 16 22 23 25 65 67 69 80 92 93 94 95 96 98 102	98g 1059	820EW 825IBL 825EW 830ECR ribbed	16x4 18x3 18x9 18x12 20x9 22x11 23x10 27x17 28x19	46 whole 6 parts 2 HS	WM	
3.12.4	2042	(533)23 (AB4)1,4,7,10, 20,23,27 (AB5)14,24,65, 67,71,91,94,223,234 (AB6)24 (AC5)13,23,28, 34,99 (AC6) 22,27,71 (AD5)1,20,54,60, 93,102,149,154,161,161A,168,178,258 (AD6)12 (BC4)1 (BD2)23, 28,45,50,71,81,100,101 (BD3)8 (BD4)17 (BE2)1, 21,32,33,37,48,68,73 (BE3)16,63 (BE4)14,19 (BF1)4,56,61,73 (BF2)1, 37,51,56 (BF3)38 (CE5)1 (CF3)2,13 (CF4)7 (FO6)2,47,132,172 (FO7)1,20,68 (FP6)92,105 (FP7)117 (FQ4)7 (FQ/R4)2 (FR3)2,14,22 (FS3)1, 4,6,13 (FT3)1 (FZ1)24 (HA2)227 gr. 207 (JE2)9 - (TG5)1,12,86,91,96 (ZH5)37	1 18 22 23 32 34 45 49 65 67 69 71 76 77 80 82 92 93 94 98 102 113 124 128	32g 60g	820EO 820EW 825EP 825EW ribbed	12x8 12x19 14x8 15x12 17x9 17x13 18x7 18x15 19x11 20x9 22x11	71 whole 71 parts 5 HS	WM	
3.12.4	2209	(AB6)1 (AD5)115 (BD2)23,26 (BD3)8 (BE2)68,73,156 (BE3)27,69 (BE4)14	1 23 25 49 67 94 95			17x12 23x17 25x23 27x15	7 whole 6 parts	WM	(BE2)256 & (BE3)69 notches in side
3.12.4	2319	(AD5)1 (AC5)34 (BD2)45,50,96,101 (BD3)28 (BE1)49 (BE3)1,10,16 (BF1)65 (BF3)38 (CF4)18 (ZH5)15	9 22 23 32 67 83 92 94 95		820EW 825EW 825EIW	26x20 28x20 30x12 37x18	2 whole 12 parts	WM	(BE3)1 worm on 1 break
3.12.4	+2333	(BE2)110 (BE3)16	13 92			45	2 parts	WM	Hellenistic?
3.12.4	+2402	(BE1)7,44 (BE4)60 (FQ3)41 (FT3)2,8	67 88 92 118		820E	14x12 20x23 21x18	6 parts	WM	imported
3.12.4	2445	(AB5)205 (BD2)71 (BE2)73,158 (FP6)81	10 67 80 83		825EP 825EW	17x12 20x14 22x17 27x15	2 whole 3 parts	WM	
3.12.4	+2530	(AB5)220 (BD2)101 (BD3)12,33 (BE2)48 (BF1)75 (CE4)1,20 (FQ3)41 (FZ2)22	13 67 87 92 111		825ER	25x18 35x18 21x18 37x23 27x8	10 parts	WM	import

Fig. no.	Type	Provenance	Fabric	Dec.	Surface treatment	Dia.	%	Man.	Comments
3.12.4	+2658	(AB4)7	18				1 whole	WM	amphora?
3.12.4	2764	(BD3)1	94		825EW	27x14	1 part	WM	
3.12.4	2982	(AB4)23,67 (TG5)65	67 102		820EO		2 parts	WM	
3.12.4	3023	(AC5)83,129 (CF4)1,155 (FP6)9,72 (FQ4)2 (FZ2)53 (TG5)1,12,75 (ZH5)37 (Z15)	18 67 94F 102 105 113 128		825EW ribbed	19x11 18x10 18x14 19x12	9 whole 6 parts	WM	
3.12.4	3042	(TG5)1,29 (ZH5)2	67 102			40x15	3 parts	WM	
3.12.4	3104	(BE2)31 (BF2)31 (CE4)58 (CF4)88 (TG5)74,115 (ZH5)15	13 67 67F 69 80 98 113		ribbed	16x8 25x25 15x9 26x19	3 whole 6 parts	WM	
3.12.4	3121	(ZH5)37	25		820EY		1 part	WM	
3.12.4	3138	(BF2)31 (CE4)4,86 (FN6)2 (FO6)160 (FP7)31 (TG5)1,12,29,75 (ZH5)85	13 23 67 80 92 94 102		830ECR	11x12 16x11 17x13 19x12 22x13 23x15 24x14 25x17 25x11	11 parts	HM WM	
3.12.4	3163	(FO6)107 (FO7)20 (FR3)14 (FS3)34 (FT3)1 (TG5)44,91	65 98 102 113		825EW ribbed	21x17 17x8 20x12	4 whole 3 parts	WM	
3.12.4	3185	(BE3)46,57,63 (FS3)3 (FZ1)24 (TG5)3	23 45 67 102 113		825EW	21x8 16x13 10x15	2 whole 4 parts	WM	
3.12.4	3341	(AD5)154	98			18x12	1 whole	WM	
3.12.4	3417	(AC5)68 (CF3)1 (FO6)34,41 (FQ4)2	92 93 102 113		825EW ribbed	20x10 19x13 8x23	1 whole 3 parts	WM	
3.12.4	3571	(JE3)3	-			41x26	1 part	-	
3.12.4	3639	(TG5)29	67			42x26	1 part	WM	
3.12.4	3672	(TG5)66	-			18x13	1 part	-	
3.12.4	3676	(TG5)46	-			33x20	1 part	-	
3.12.4	3681	(TG5)29	67			15x14	1 whole	WM	
3.12.4	3682	(CF4)102 (TG5)29,74	67 92 106			30x22	3 parts	HM WM	
3.12.4	3713	(AC5)128 (AD5)224 (FZ1)10 (TG5)122	92 92C 113 128		825EW	17x14,5 16x14 22x12	4 parts	HM WM	
3.12.4	4318	(BF3)8 (TG5)1	80 102			13x8	1 whole 1 part	WM	
3.12.4	4321	(TG5)1	141			60x21	1 part	WM	
3.12.4	4323	(CF3)22 (TG5)1	106 132			20x12	2 part	HM WM	
3.12.4	4638	(FO7)68	110			17x14	1 whole	HM	
3.12.4	4718	(FP7)12	110			13x12	1 whole	HM	
3.12.5	1020	(BE3)27 (BE4)37 (BF1)11 (BF2)56 (CE4)14 (CF4)56 (FZ1)9 (HA2)2	65 67 69 92 94 110		825EW	-	8 parts	HM WM	associated with e.g. 2171x
3.12.5	2208	(BE4)14,19	92	1000 1012		23x12	1 whole	HM	

Fig. no.	Type	Provenance	Fabric	Dec.	Surface treatment	Dia.	%	Man.	Comments
3.12.5	2236	(BE4)16,20	67 94	1012	825ER	28x14	2 whole	HM	
3.12.5	2407	(BE3)26	67	1030		-	1 part	HM	
3.12.5	2673	(AB4)10 (AD5)112 (BD2)71 (BF1)73 (FQ3)30 (FS3)6 (TG5)29	67 76 80 97 117 124		H825ER	20x21 17x17 14x16	3 whole 6 parts	WM	horizontal
3.12.5	2696	(AB4)11	67			21x14	1 whole	WM	
3.12.5	2723	(BE1)76 (TG5)74	23 94		820ER	7x3	1 whole 1 part	WM	
3.12.5	2726	(BE2)71 (TG5)74	80 92			19x13	1 whole 1 part	WM	cf.2501x (3.6.11)
3.12.5	2729	(BE2)88	67			19x18	1 whole	WM	
3.12.5	2803	(BC2)4 (BD2)94 (CE4)1 (CF3)24	65 67 92 110			9x9 15x12	4 parts	HM WM	(BD2) - arm of figurine?
3.12.5	2831	(AC6)22,30 (CE4)2 (TG5)1,6,7	54 67 92F 110 115		822W	10x15 18x12 8x8 9x7	3 whole 3 parts	HM WM	
3.12.5	2856	(FZ2)1	92		825ECR	31x16	1 part	HM	
3.12.5	2873	(AB5)211 (FZ2)1	11 92		825ECR	18x20	2 parts	HM WM	
3.12.5	3352	(AD5)160 (TG5)74,114	80 92		820IBR 825EW	20x20	1 whole 2 parts	WM	horizontal
3.12.5	+3389	(AD5)112	67	1133	825EP	28x26	1 part	HM	
3.12.5	3751	(AD5)226 (TG5)73	92 94		820FO	16x10	1 whole	-	
3.12.5	3772	(AC5)82	89		825EIR	-	1 part	HM	
3.12.5	3981	(ZH5)37	113		825EW	29x12	1 part	WM	
3.12.5	4094	(TG5)95	-			20x12	1 part		
3.12.5	4201	(TG5)95	-			-	1 part		
3.12.5	4512	(JC3)6	1	1234	805E	29x12	1 part	HM	
3.12.5	4555	(CE4)48	130	1241	825ER	26x17	1 part	WM	
3.12.5	4617	(TG5)4	92	1253	825EP	33x17	1 part	WM	
3.12.5	4646	(FO6)167 (FP6)89 (FZ2)1	106 110C 117			12x18 18x18	3 parts	HM	
3.12.5	4699	(FO7)90	67			30x12	1 part	HM	
3.12.5	4736	(BE1)80	92			-	1 part	HM	unfired

4. Decoration on the ceramic vessels at Kawa

Decorated vessels are relatively rare in the Kawa assemblages. In the late Napatan or early Meroitic periods ornamentation tends to consist of incised straight and/or wavy lines and is more rarely painted on with a slip. In the mid to late Meroitic period painted decoration, generally consisting of plain bands or floral motifs, is common on the slipped wheel-made beer jars. In this period there are also some rare (at Kawa) instances of painted or stamped fine wares (almost exclusively found at site R18), although their rarity across the town site is most likely due to the excavated areas not having been in use in the first centuries AD. In the earlier Napatan period decoration is extremely rare and generally confined to a red band painted around the rims (interior and exterior) of bowls and cups, as well as finger impressed dots or a piecrust decoration on jars and triangles with impressed dots, distinctive but not common, except in Area C. However, in the Napatan period there are also a number of vessels with appliqué animals on the rims, usually found on oval basins, perhaps for ceremonial/ritual use. Interestingly, there are contemporary parallels in the ancient Greek world, in particular among late Geometric pottery (7th through 6th centuries BC). See for example Attic *pyxis* lids with horses as handles (<https://www.wikiart.org/en/ancient-greek-pottery/attic-late-geometric-pyxis-with-four-horses-on-the-lid-from-kerameikos--735>), or a very unusual *olpe/oinochoe* in late geometric style in the Paolo Orsi archaeological museum of Siracusa, with two lions on the rim. These parallels are more of a match to the animal figurines found at Kawa (broken off at the base), but nevertheless provide a (tenuous) parallel for faunal appliqué decoration (see Welsby and Taylor forth., cat. no. F-481 ff.).

Note: in some instances, the distinction between decoration and graffiti is not straightforward, particularly when an incision is fragmentary, and may either have been part of a potter's mark or a (more or less) decorative pattern.

Discussion

The decorative motifs have been divided into eight categories (see below). Many only occur once, but are nonetheless often part of a particular type of decoration, as can be seen from the arrangement of the decoration type series. Some are not strictly speaking decoration, such as the basket impressions, resulting from making the pot on a mat; whether this was done to give the pot a specific finish, or to give the pot non-slip properties or was simply the consequence of the potter working on a mat, is open for discussion. Lugs would of course have had a practical use, making the vessel easier to handle, but the shape of the lugs could also be regarded as decorative (reminiscent of crocodile skin, perhaps?). The rounded bosses are surely purely decorative.

Decoration on the rim top is not very common, except in the case of 1017y, 4.2, which is probably early Meroitic in date. Generally rims were left plain or decorated with a band of red slip, usually on both sides of the vessel near the rim, covering the top (RBRIE, RBR TOP, etc.), particularly

in the Napatan period. The use of red slip by the rim is so common (whether applied carefully or not) that it almost seems to have been a requirement – whether decorative or for other reasons, such as to ward off evil.

Incised decoration is generally more common in the Napatan contexts, whereas impressed and rocker-stamped patterns come to the fore in the Meroitic. Some incised 'decoration' motifs have on second thought been moved to the Graffiti section, as they are more likely to form part of a potter's mark or a symbol, rather than being purely decorative. These were generally made before firing, which explains why they were not originally classed as graffiti.

The type of decoration represented by 1204y (4.6) is particularly interesting; it is crude and rather ugly, a combination of incised triangles arranged in a variety of ways but always infilled with punctated dots, filled with a white substance (chalk?). At Kawa this type of decoration features on large handmade bowls, but it is very similar to the decoration found at Sanam Abu Dom, el Kurru and Nuri (see 1204y, below), in contexts dating to the early 7th century BC, albeit on slightly finer bowls, and covering the whole body of the vessel, while 1204y mostly appears to feature as a single register. The parallels are thus not necessarily of the same date, but the style of decoration certainly is. At Kawa it is stratigraphically possible that 1204y belongs to the early Napatan period, but it does occur especially in Area C, which on the whole is later in date.

In the Meroitic period, especially from the 1st century BC onwards, painted decoration appears to become suddenly very popular, a complete break with the Napatan period. Nothing in the Napatan repertoire even hints at what is to come, suggesting outside influences at work, from Hellenistic Egypt in the first instance. On jars patterns range from simple horizontal brown bands on an orange or reddish slipped background to undulating lines and floral motifs, while the few painted Meroitic cups found (mainly in the excavations in the cemetery) have a mixture of floral and geometric motifs, as well as symbols, such as the *ankh*. Rouletted and impressed decoration features on the handmade black burnished vessels, a ware that is however rare at Kawa. It is often made from the quartz-rich fabrics, Fabric 58 for example, making it very similar to the Neolithic period Fabrics 5 and 42, in particular the former. As vessels in the much earlier period are also adorned with similar styles of decoration, this should be borne in mind when studying survey material or unique finds from excavated contexts.

All decorative types are suffixed with a 'y' and have been grouped according to the following characteristics, and illustrated in Figures 4.1-4.9 and Plates 4.1 and 4.2. See also Table 4.1, for further information:

- Basket impressions¹ and other non-decorative interventions to the pot (Figure 4.1).
- Bosses, lug handles and piecrust decoration, in particular 1000y (Figures 4.1 and 4.2).

¹ For a discussion of the basketry from Kawa see Wendrich, forth.



Plate 4.1. 3831x, 1167y (FO6)37
Finger marks on interior, the result of the manufacturing process.

- Rim Decoration (Figure 4.2).
- Incised Decoration (Figures 4.3 & 4.4).
- Appliqués (Figure 4.4)
- Impressed, roulette, rocker stamp (Figures 4.3 & 4.5)
- Punctated and incised, slip painted (Figures 4.6 & 4.7).
- Stamped (Meroitic) Figure 4.7.
- Painted decoration (Meroitic), on fine wares (bowls and cups) (Figure 4.7) and on jars (Figures 4.7-4.9).

4.0. Not illustrated here, but present on the forms

Information of manufacture and provenience is listed in the first part of Table 4.1.

855e: String marks on body, e.g. 3558x (3.2.10). String marks are often an indicator of New Kingdom period ceramics, but none of the few examples at Kawa date to this period, but rather to the Meroitic.

5y: Close-weave basket impression, typical of a certain type of *Kerma Classique* cooking pots, but not restricted to that period. Equivalent to a 'plaited strip-pattern' (Phillips 2010, 230, fig. 2)

1010y: Oblique finger marks, a Napatan technique of smoothing the surface of a handmade jar; cf. Mohamed Ahmed 1992, IA19A, phase 2. Note that while only three examples of this type of manufacture are recorded at Kawa (2167x (BE3)1, 3.3.6; 2256x (AB5)263, 3.7.16; and 3938x (FQ4)98, 3.3.5), a notable number of handmade narrow necked jars have 'scratches' on the shoulder (4765x, 4767x, 3.3.3; 3938x, 3.3.5; 3108x, 3.3.6; 3501x, 3.3.7). Exactly what they could mean or result from is not known, but considering the number of instances, there might have been a reason for the application of the marks.

1137y: scar inside pot from joining the base to the wall and rim, cf. especially 3823x (3.7.6 and Plate 4.1).

4.1. Thickened bases, basket impression, bosses/lugs

8y: Thickened base (of cooking pots). An extra layer of clay added to the exterior base of cooking pots, showing numerous thumb (?) marks. Presumably this was done both to make the vessel more stable over a cooking fire and through the thickening avoiding the contents burning. Slight variations occur where the thumb prints are replaced

by a thick, rough layer of clay that has not been smoothed, maintaining the stabilising effect. The same device occurs in the *Kerma Classique* and also in Medieval contexts (not at Kawa, but in Nubia in general).

200y: Mat or basket weave, more commonly occurs on the underside of flat-bottomed basins, and on the sides of some coarseware pots.² This type of pattern seems to occur from the New Kingdom onwards. See also Phillips 2010, fig. 1.

1087y: A colander fragment. For vessels that may have functioned as colanders, see Figure 3.8.3.

1187y: As the only example of this 'decoration' was found on the interior of a *doka* sherd, it is possible that it has a practical function, to make the bread easier to remove after cooking. Alternatively, similar markings have also been recorded as graffiti, but in view of the present mark's location on the interior of a utilitarian dish (and its fragmentary state), it seems more likely to be functional in nature.

1188y: herring-bone pattern, basket weave or incised. When it is impressed through contact with a mat or basket, the weave is known as 'diagonal twill' (Phillips 2010, fig. 6); usually this surface finish dates to the late Medieval period, but there is no reason to believe the sherd found in Building F1 is anything but Napatan; the occurrence at site R18 is a hand-incised decorative pattern, either Meroitic or of (residual) *Kerma Ancien* date.

1194y: basket impression, see for example Phillips 2010, fig. 4B (Kerma and Proto-Kushite date).

1248y: Textile impression on the interior of a base (possibly a lid knob?), fine threads.

1000y, 1003y, 1004y: Bosses, lug handles and pie-crust decoration (1000y).

4.2. Bosses, rim-top and below rim decoration

1002y: Notches cut by external edge of rim for decoration. Similar to 1017y, but the latter does not occur with other forms of decoration and is used on the simple rims of cooking pots.

1085y and 1231y: These types of roughly executed wavy line occur on Second Intermediate and also 18th Dynasty bowls (Rose 2017, figs 1.4 and 4.14), but in the instances at Kawa the contexts in which they were found are of Meroitic date.

1136y: Impressed band below rim on shoulder, post-Medieval (Islamic) in date, cf. 3539x (3.3.8).

1138y: Grooves cut in the rim post firing, but included in decoration as the form is so different from the amphora forms, where this phenomenon usually occurs, there thought to be for a practical reason, to facilitate the removal of stoppers.³

1198y: Griffith 1923, pl. LXVI.1. This type of decoration also occurs as a pot mark on Urartian jars, albeit not in a context that is likely to be linked to Kawa (Derin 1999, fig. 1.I.3); it is possible that it endowed the rectangular token (?) with meaning, whether symbolic or practical (weight)?

1174y: Impressed and incised decoration, similar to Laming Macadam 1955, II, pl. XXXIII [2171], although in Laming

² It is also to be found on the underside of a ceramic offering table found in the cemetery, see Welsby and Taylor forth., cat. no. F-528.

³ For further discussion see **Bungs** in Welsby and Taylor forth.

Macadam there is a row of small bosses by the rim, rather than impressed decoration.

4.3. *Incised, impressed and rocker stamped decoration*

1007y: Roughly incised criss-cross decoration by the rim.
1119yb: *Kerma Ancien* decoration, on residual sherd in R18.

4.4. *Incised and moulded coarseware decoration and faunal appliqués*

Appliqué fragments. See also forms 3001x (3.6.1) and 3084x (3.9.7) and small finds catalogue nos F-481, F-482, F-484, F-485 and F-491 (Welsby and Taylor forth., fig. 4.13).

1001y: A boss with a stamp, bearing a scarab flanked by two *uraei*, just below the rim of a bowl (2030x, 3.7.8). Unique at Kawa and no direct parallel has been found. Note that 31g (Figure 5.9) was incised next to it. For a brief discussion, in the context of the seal impressions on mud from Kawa, see Vincentelli forth.

1066y: Fragment of a crocodile tail, or possibly a snake in some cases?

1153y: Incense burner (3863x, 3.11.5) with either broken-off bosses around the rim, or, given how unevenly they taper towards the broken ends, the legs of e.g. birds?

1195y: Laming Macadam 1955, II, pl. XXXIII [2171], identical incised decoration, but in the parallel this sits below a row of small bosses (like 1040y, 4.2)

4.5. *Impressed, roulette and rocker-stamped decoration*

This is often over the whole body of the pot, and essentially of Meroitic date, despite presenting many similarities with Neolithic decoration. In R18 there were however a number of residual sherds of Neolithic date.

1284y: Possibly the rim of a caliciform beaker.

4.6. *1204y and variations with slip decoration*

1204y: Same decoration but not form at el-Kurru (reign of Shebitqo, 701-690 BC) (Dunham 1950, 104-105, fig. 35c) and Sanam Abu Dom (Griffith 1923, 103, pl. XXXIII.11; Lohwasser 2010, pl. 1 and fig. 32, an incense burner with 1204y decoration), as well as a RBRIE bowl with 1204y (Lohwasser 2010, pl. 18, grave 218) and a regular RBRIE bowl (*ibid*, pl. 19, grave 0143); Nu.71 (8) fig. 32 17-12-37. Some very abraded sherds with this kind of decoration were also found in a sondage at Gala Abu Ahmed (Jesse and Kuper 2006, 139-140, pl. VI.5 and VI.7).⁴

1233y: A variant of 1204y; Lohwasser 2010, pl. 1, fig. 32, incense burner with same pattern, from Sanam Abu Dom.

1295y: This rather discreet punctated decoration on form 2757x (BF1)72, almost hidden by the slip, has parallels in 2787x from (BD2)28, (but no pattern could be discerned,

⁴ The authors make reference to a possible parallel amongst the post-Medieval pottery in the Southern Dongola Reach (Jesse and Kuper 2006, 140, footnote 1), but the Gala Abu Ahmed sherds resemble type 1204y much more closely.

just the technique) and in 1095y, which however is clearly part of a pattern and part of the 1204y type of decoration.

4.7. *Slip decoration, stamped and painted Meroitic fine ware decoration, as well as symbols on beer jars*

The fine-ware Meroitic cups, made with Fabric 26 and bearing either painted or stamped decoration date to the 1st-2nd centuries AD (David 2019, 880 ff.).

1054y: Very unusual decoration on the body of a medium-sized closed wheel-made jar; the pattern unclear. It looks as if it has been applied with a stencil, or what we see is the negative of an appliqué pattern that has fallen away (Plate 4.1, 1054y).

1162y: *Ankhs* painted on a bowl (?) with black outline and white infill, on a red slip. Cf. Bąkowska 2010, 197, fig. 7b.77, similar *ankhs* and background, but with the addition of lotus flowers, dated to mid 1st -mid 2nd centuries AD.

1167y: An unusual amount of slip dribbles on a red-rimmed bowl. Intentional or accidental?

1178y: Meroitic stamp, Shinnie and Bradley 1980, fig. 57.d

1179y: Meroitic stamped cup, David and Evina 2016, fig. 28 (Sedeinga II T 203 Cd 02). Note the indication of the reverse of the stamped decoration on the interior, just like in the present specimen, where the ripples in the still-wet clay can still be made out.

1263y: Meroitic stamped cup, similar to 1178y and to Shinnie and Bradley 1980, fig. 57.c; Török 1997, II, fig. 90.15.

1272y: Painted on base. Garcia Guinea and Teixidor 1965, fig. 15.2 (Nellulah, tomb 10); Reisner 1923, fig. 12 1 & 3 (Kerma Meroitic cemetery K 1-38), 1 has a similar design on body. This design on the base of fineware cups occurs on several other similar cups, e.g. David 2018b, fig. 5 (Sedeinga); Woolley and Randall-MacIver 1910, pl. 79, 8473. G764 (Karanog).

1273y: Painted lotus flower, Garcia Guinea and Teixidor 1965, pl. V b (Nellulah); Griffith 1924, pl. L.8 (Faras); Laming Macadam 1955, II, pl. CV(ii)a (Kawa).

1278y: cf. fig. D10 Shinnie and Bradley 1980, fig. 54.h; Török 1997, II, fig. 86.71 and 72.

1279y: Painted flowers, Laming Macadam 1955, II, pl. 84.e (Kawa).

1285y: Shinnie and Bradley 1980, fig. 83 (not on a pot, but on a terracotta pot stamp).

1291y: Painted, Meroitic. Cf. Török 1997, II, pls 30, 32, 33, for the same motif in plaster from M195 at Meroe.

1292y: Painted, resembles a double version of the Meroitic hieroglyph for 'p' (cf. Griffith 1911, 11).

4.8. *Painted decoration on Meroitic jars.*

1173y: Undulating line below dark horizontal bands, cf. Török 1997, II, fig.112 297-3 Meroitic date, from Aswan.

1223y and **1262y:** Vincentelli 2006, fig. 2.76 480, Hillat el-Arab, tomb ARA 16: also only sherds, of Meroitic date.

1283y: Painted, Bonnet 1990, 239 no. 357, 1st century BC.

1293y: Black floral decoration on jug; cf. similarity of decoration to that on a smaller jug at Meroe (Beg.W.284 – see also discussion of the vessel itself, 4333x, 3.2.10).

4.9. Painted decoration on Meroitic jars.

More fragmentary floral motifs, the full decorative band 1276y from beer jar 4804x (3.2.7) and the (incomplete) decoration 1286y from the *krater* 4810x (3.2.9).

Painted decoration, not drawn.

1057y: Cream or white paint splodges, seemingly random paint dribbles criss-crossing each other (Plate 4.2).

1146y: Curving and straight white bands, motif unclear on a jar (Plate 4.3).

1148y: Thick brown horizontal band around the neck of a beer jar (Plate 4.3).

1261y: Multiple registers of thin red and brown horizontal bands on the shoulder and body of a jar (Plate 4.3).

1296y: Red, brown and red concentric circles against a cream background. From a Late Helladic II *askos*? The fabric has the creamy colour of a marl, and is most likely Aegean in origin. A complete vessel of this type was found in a burial at Sai (V. Francigny, pers. comm.) (Plate 4.3).

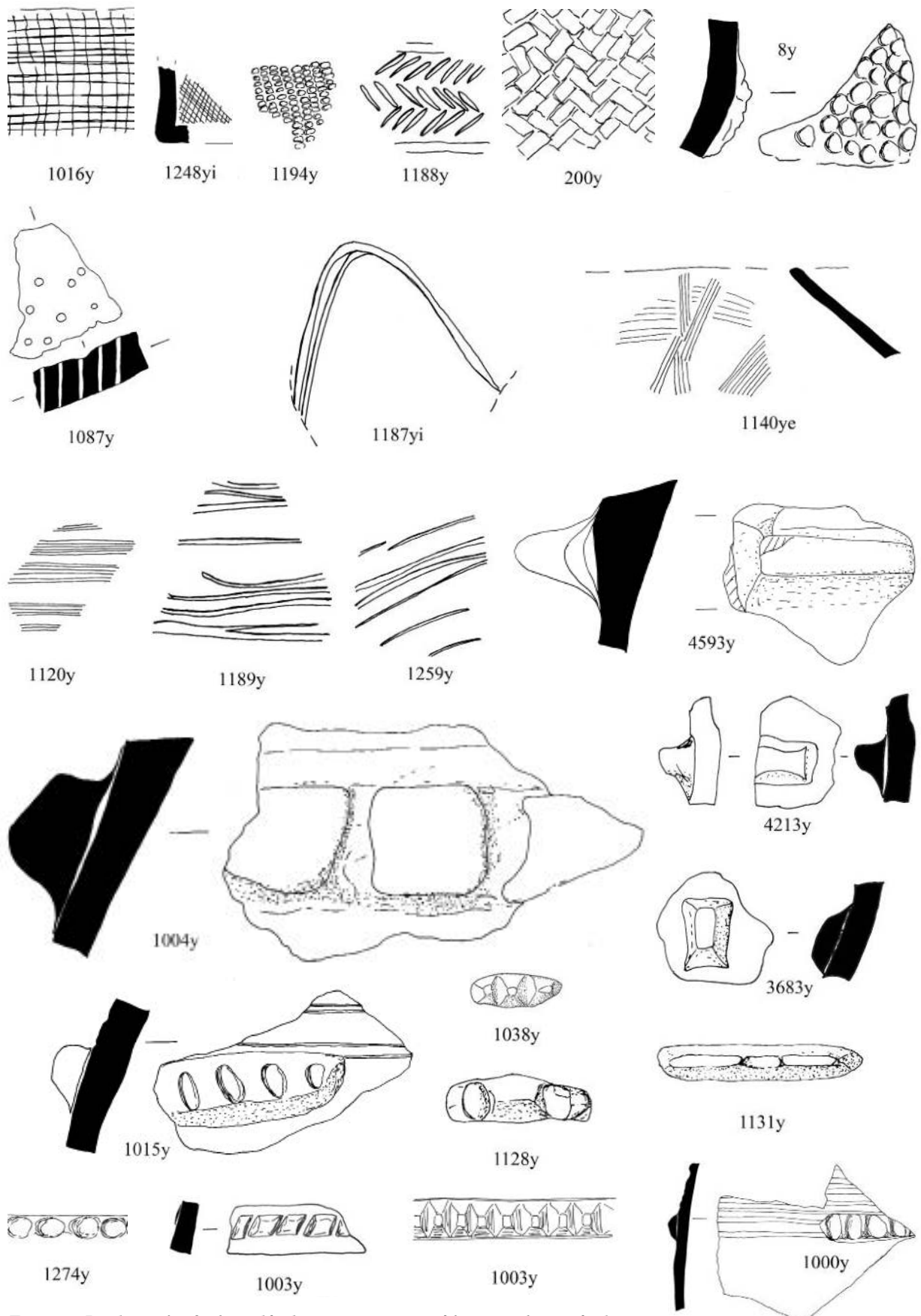

Figure 4.1. Random surface finishes and basket impressions; practical features, such as a colander and lug handles; variations of piecrust decoration. 1004y is at scale 1:4, others are at 1:2.

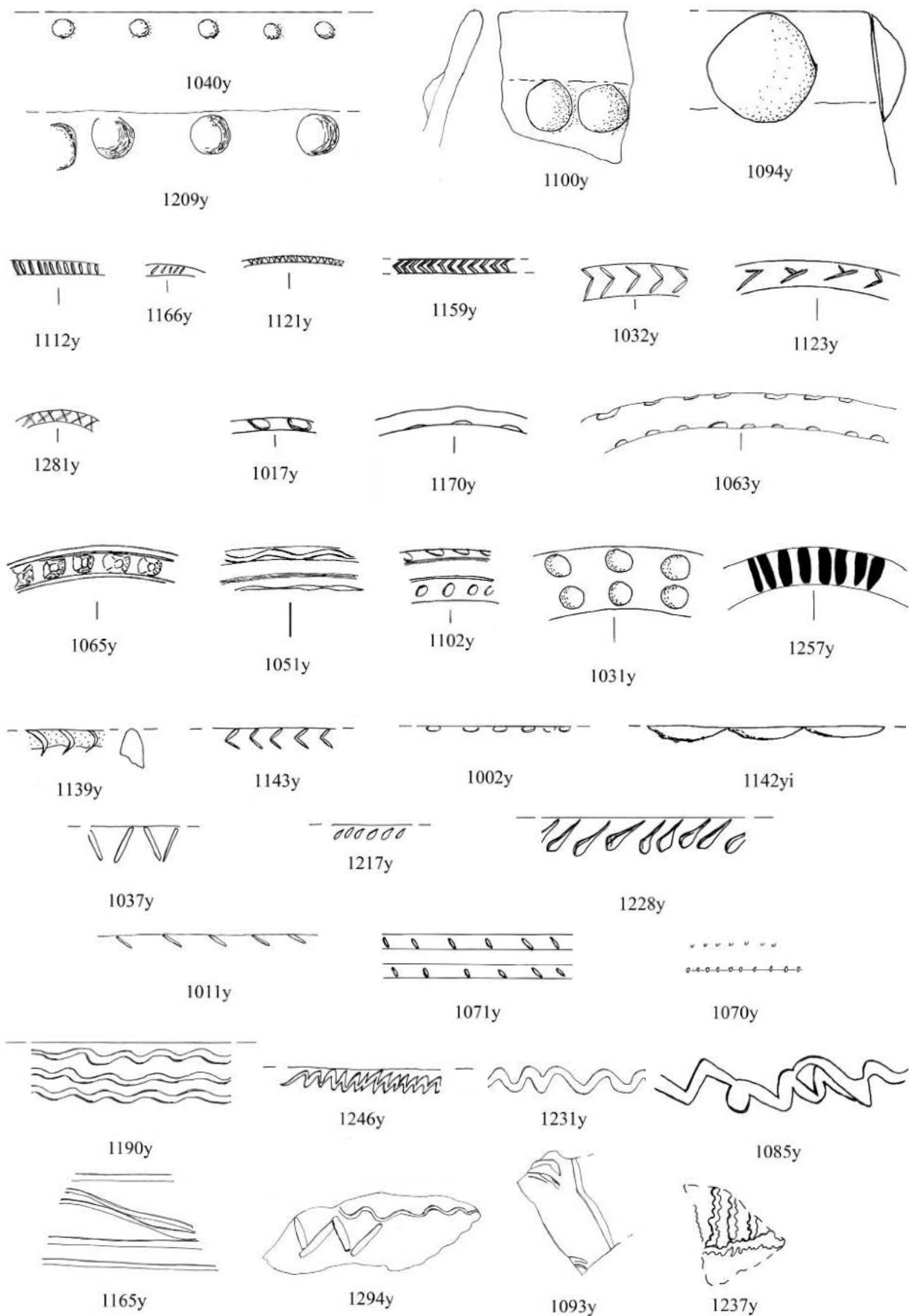

Figure 4.2. Bosses, rim decoration and decoration just below the rim (scale 1:2).

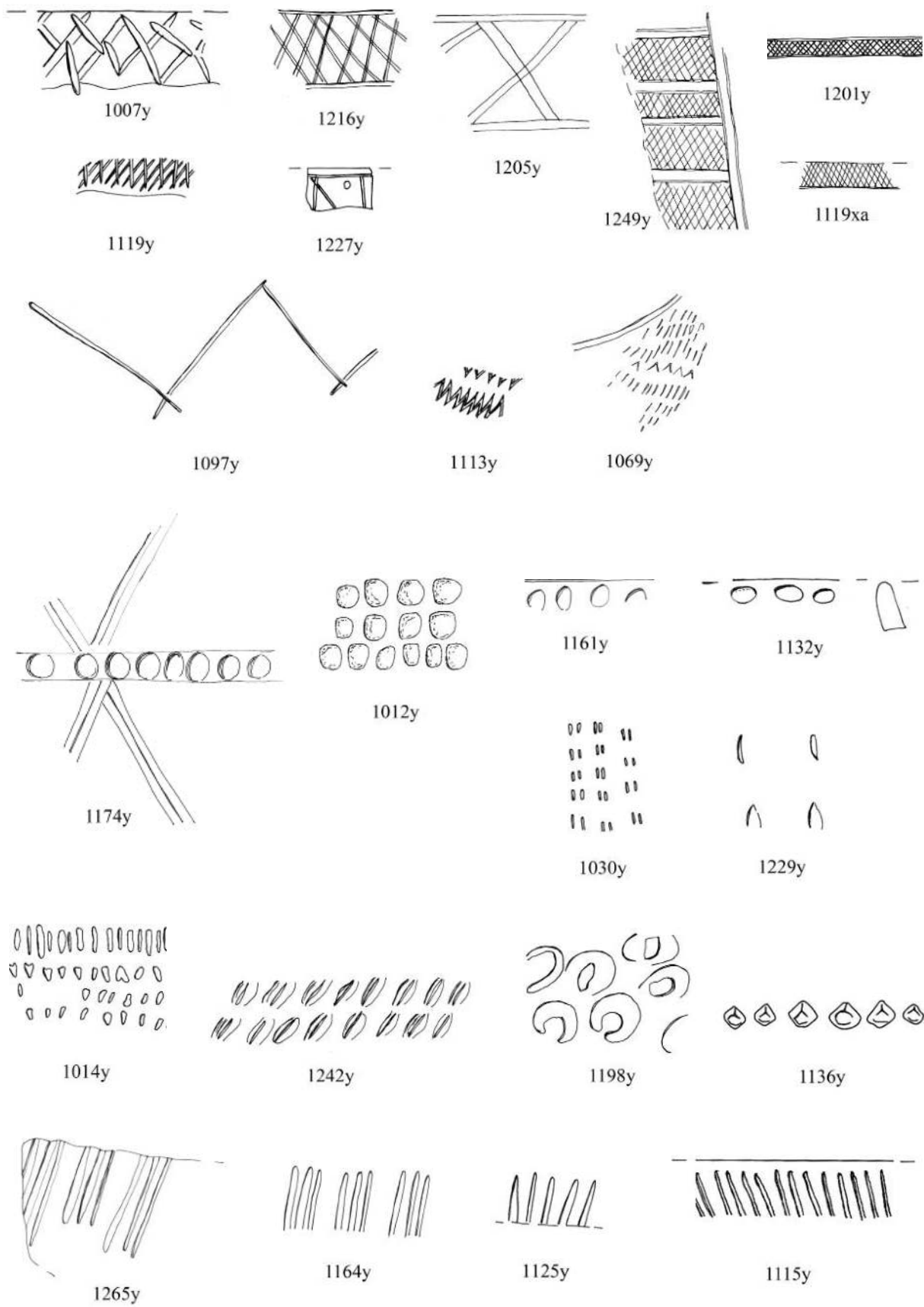

Figure 4.3. Impressed, incised and rocker-stamped motifs (scale 1:2).

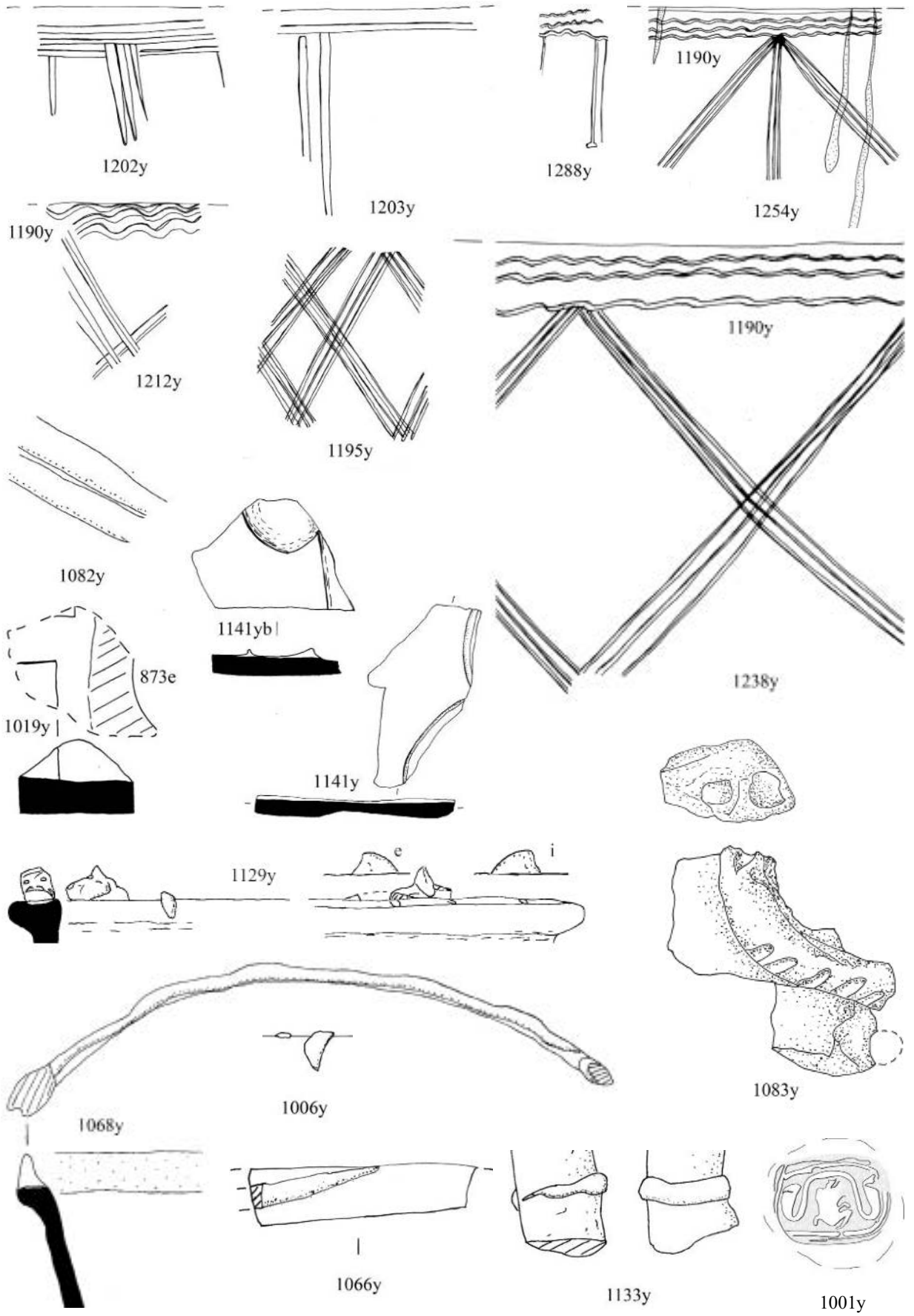

Figure 4.4. Incised and moulded coarseware decoration and appliqués (scale 1:2).

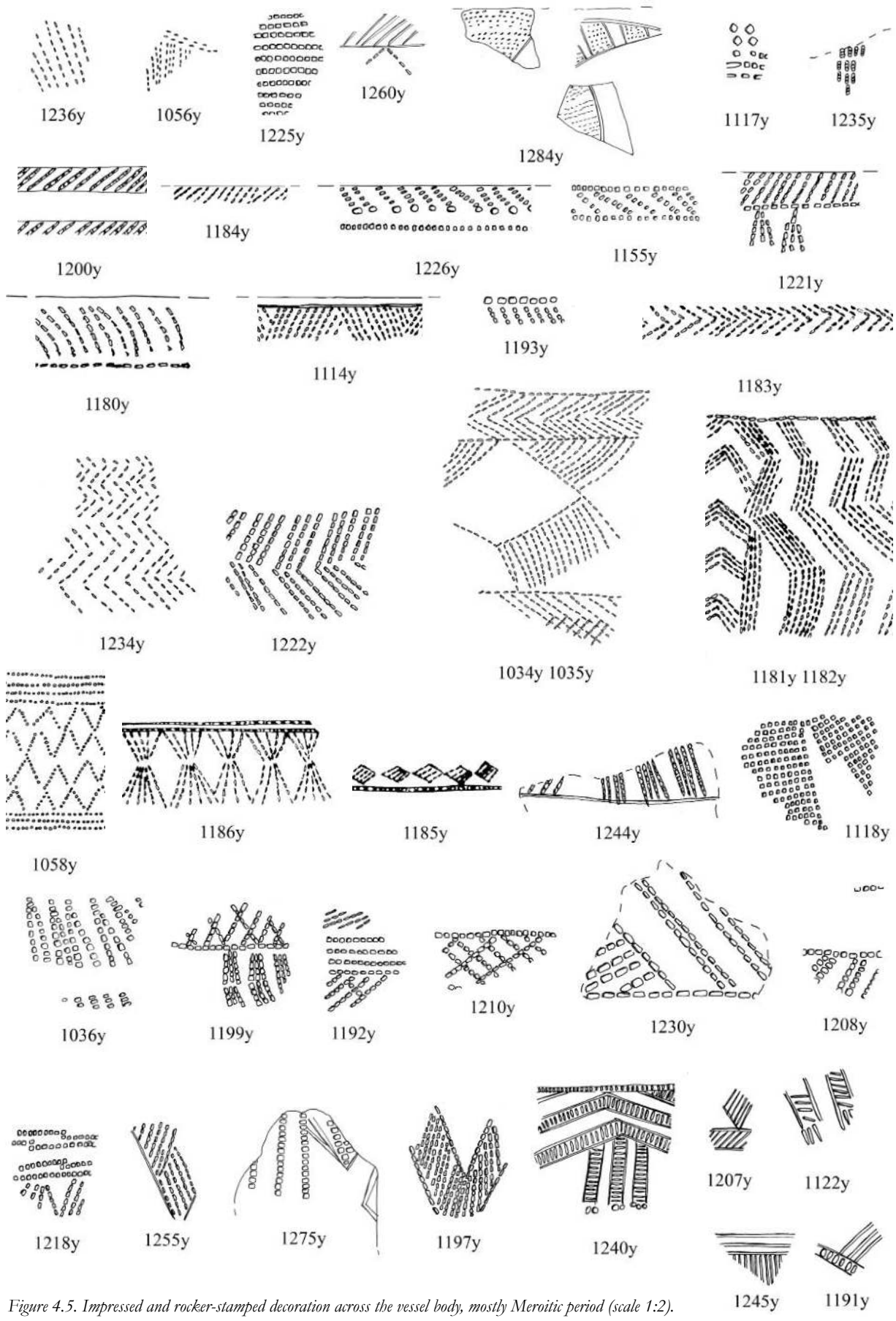

Figure 4.5. Impressed and rocker-stamped decoration across the vessel body, mostly Meroitic period (scale 1:2).

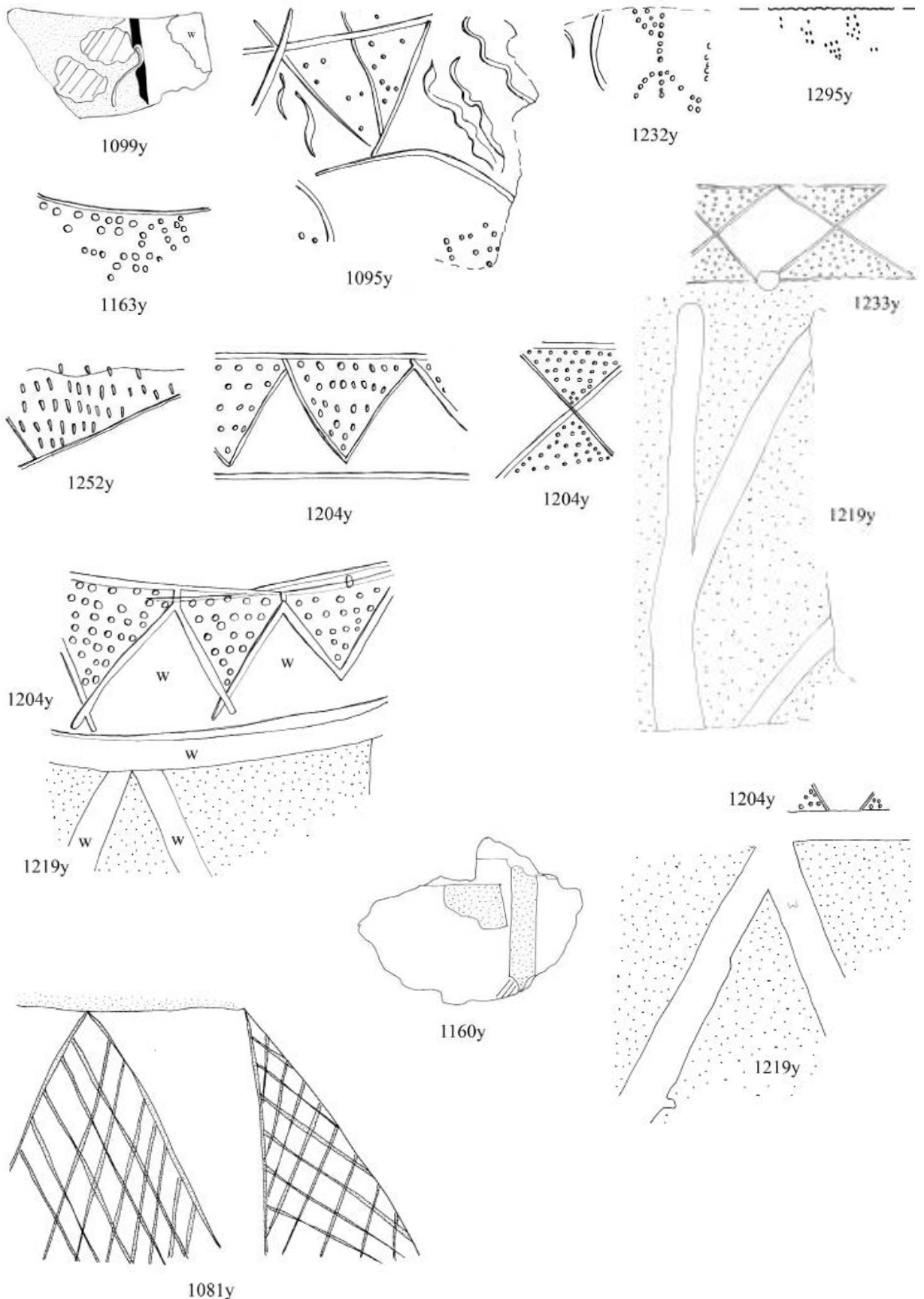

Figure 4.6. Incised and punctated decoration on Napatan jars and bowls. White infill survives in some of the holes (1204y and similar). Slip-painted decoration (1081y) (scale 1:2).

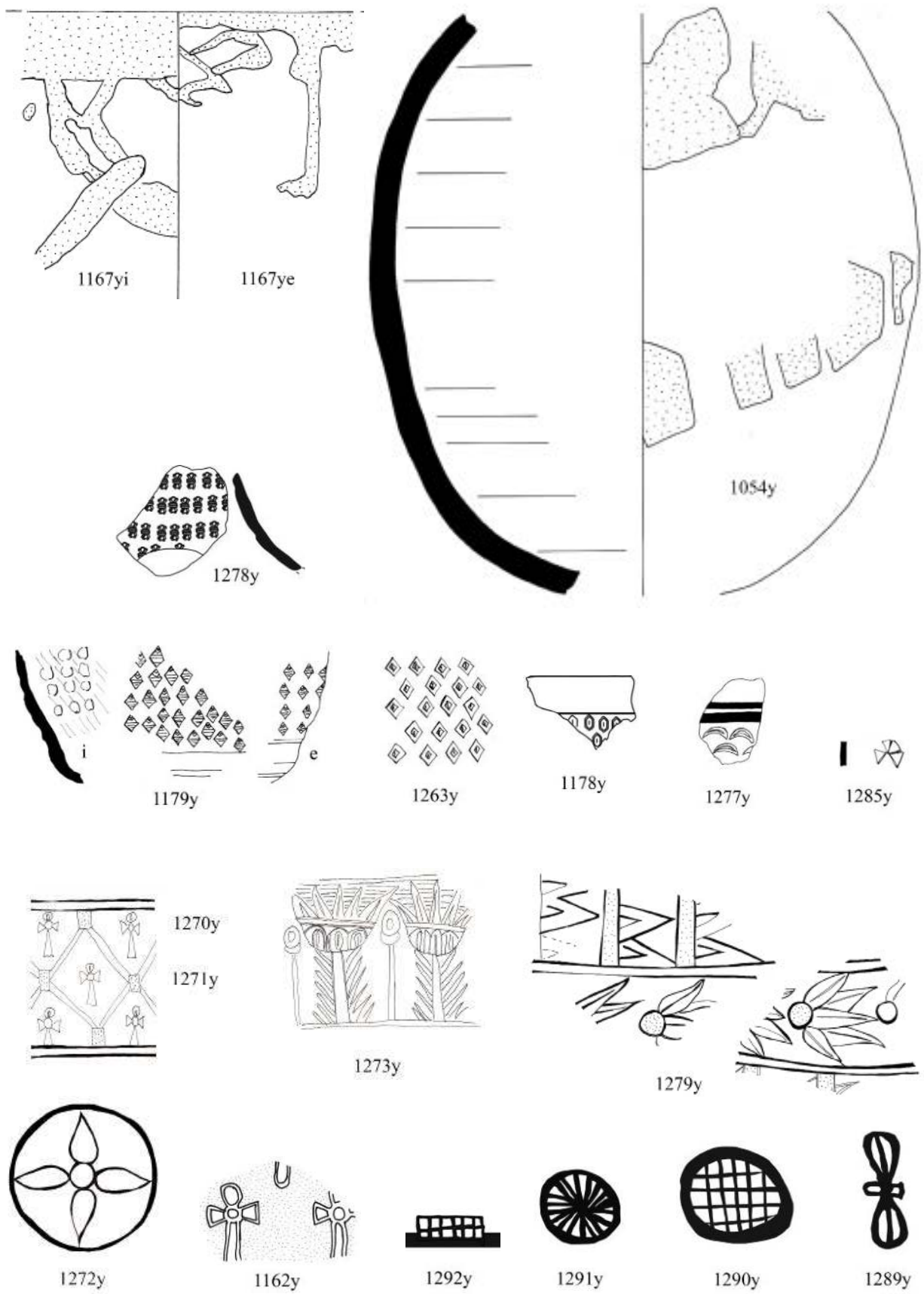

Figure 4.7. Coarser variations (1054y and 1167y) of slip decoration; stamped (1178y, 1179y, 1263y, 1277y and 1285y) and painted decoration on Meroitic cups (1270-1273y), bowls or flagons (1162y and 1279y) and jars (1289-1292y) (scale 1:2).

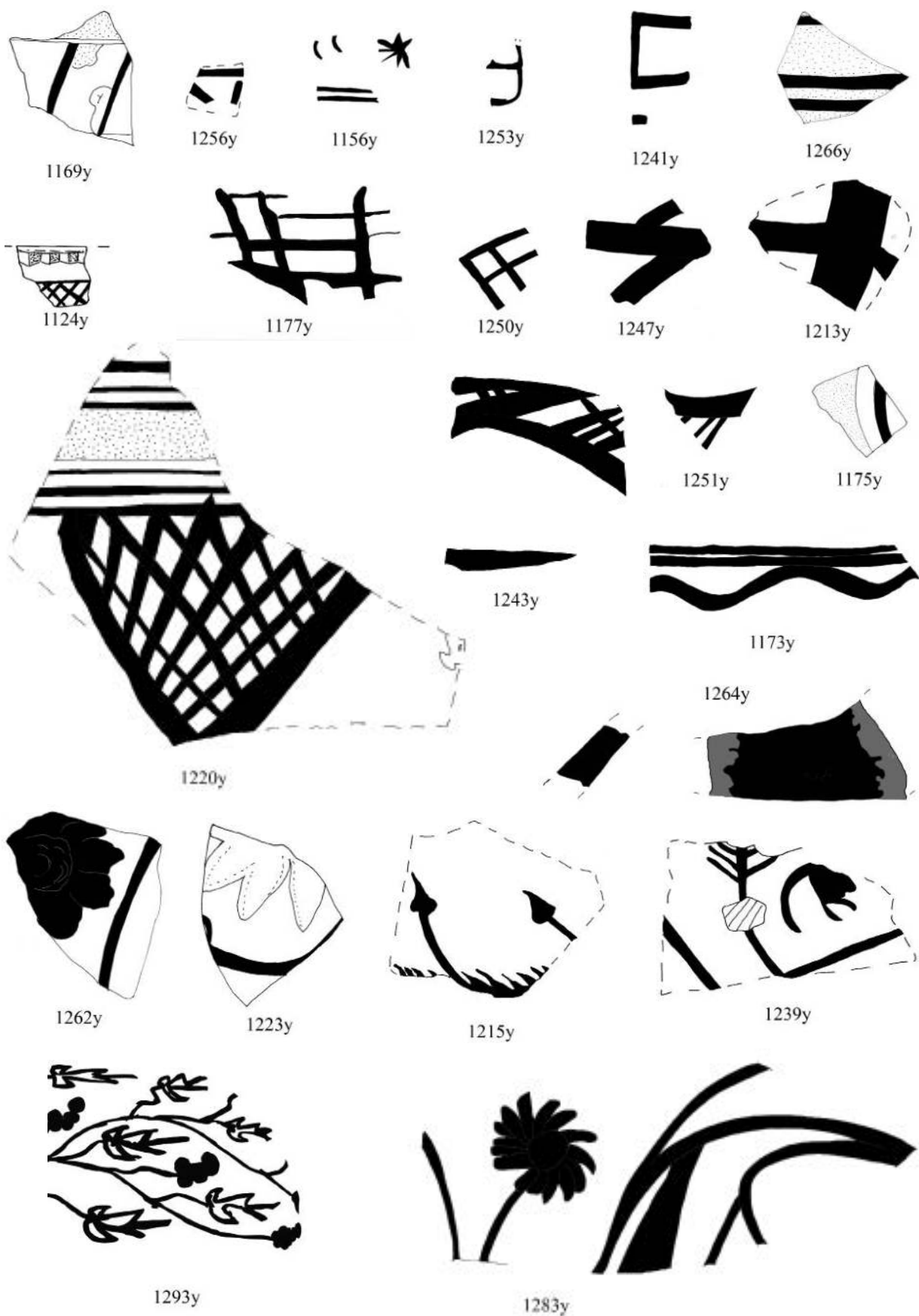

Figure 4.8. Painted decoration on Meroitic period jars (scale 1:2).

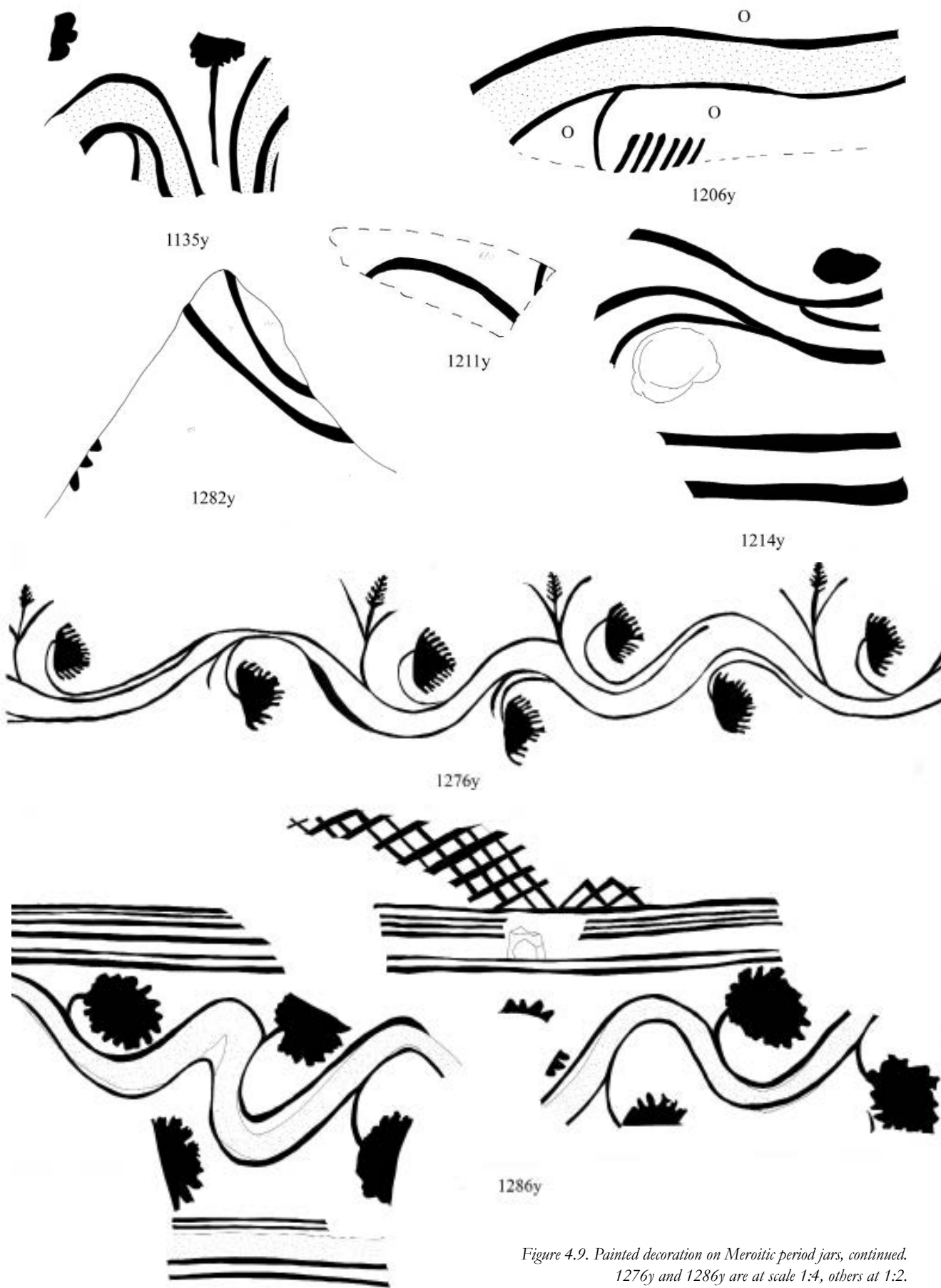

Figure 4.9. Painted decoration on Meroitic period jars, continued.
 1276y and 1286y are at scale 1:4, others at 1:2.



Plate 4.2. A selection of decoration types, including 1057y (not drawn).

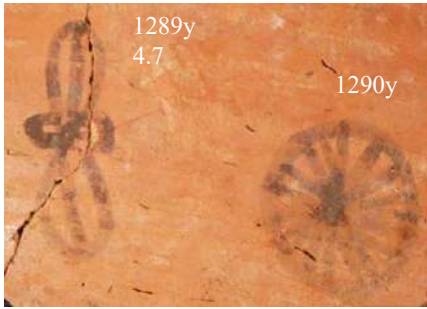

Plate 4.3. Miscellaneous painted motifs, including 1146y, 1148y, 1261y and the Aegean import 1296y (not drawn).

TABLE 4.1. TYPES OF DECORATION.

Fig. No.	Provenance	Type	Form	Fab.	Surface & other dec.	Sherd	Man.	Comment
0	(AB5)32 (AC5)28,127 (AD5)87,112,148,153,160,206 (CF4)1 (FP6)109,125 (FR3)4 (FZ2)49 (JE3)1,2 (JG1)13 gr. 12 (JG2)178 gr. 175 (TG5)18,73,29-74 (ZH5)62	2821 3558 3652 3844 4444	amph jar	67 69 76 80 92 93 92F 94 106 112	825EBL	BS R PRO	HM WM	string marks on body of vessel
0	561 2 (AC5)169 (BD2)47,50,63,71 (BD3)16 (BE2)48 (BE4)9 (BF1)57,73 (CF3)2 (FO6)15,157 (FO7)44,68 (FP6)9,109 (FP7)31 (FZ1)10,25 (JG1)13 gr. 12 (JG2)1	300a 2000 2001 2039 2117 2124b 2283 2325 2340 2344 2348 4811a	bowl CP cup	1 2 3 11 67 92 94 110	820IR 910 RBRE RBRIE	BS R	HM	basket impression, close weave
0	(AB5)263 (BE3)1 (FQ4)98	2167 2256 3938		67 94		R	HM	oblique finger marks on body
0	(AC5)131 (AD5)162,268 (CF4)117 (FO6)62,71,134 (FP6)1,29,31,138,154	2880 2971 3405 3469 3497 3808 3831 3862 4713	bowl	92 110	RBR TOP RBRIE 910 805E	BS R B PRO	HM	impressed
4.1	+8 1098 4 (AB4)27,33 (AB5)41A,64,65,91,94,338 (AB6)10 (AC5)1,8,23,28,34,37,38,45,46,49,50,53,55,62,67,70,73,78,79,92,99,105,107,108,111,112,114,116,117,124,126,127,128,129,131,145,162,167 (AC6)1,17,79,84 (AD5)1,28,41,61,80,87,97,99,107,112,113,116,117,128,133,134,135,136,161,163,168,175,178,182,183,190,192,194,198,203,205,207,211,214,217,225,227,230,235,242,246,249,256,258,259,260,262,268,272,273,276,278,281,283,287,288,289,315,318 (AD6)13,16 (BC4)1 (BD2)34,65,100 (BD3)9 BD4 13,17 (BE2)9, 19,33,37,50,109 (BE3)9,16,26,27,50,53,55,57,64,70,78,106,118 (BF3)8 (CF3)34,36,74 (CF4)20,93,123,133,159,166 (FN6)3 (FO6)19,54,62,109,113,114,121,122,125,148,185A (FP6)1,9,24,32,54,57,60,92,96,128,131,153,156,159,169 (FP7)59,191 (FQ3)3,9,33,43,48,58 (FQ4)2,6,20,22,27,33,70 (FR3)0,2,14,19,22 (FS3)1,3,6,9,11,34,39 (FT3)1 (FZ2)1 (GD3)0,12,92,97,125,139 (HA2)46 (JE2)15 (JE3)113 (JG1)13 (JG2)1 (TG5)1,6,29-74,44,65,73,74-90,87,94,95,97,99,103,113,130,137 (ZH5)15,36,37,43,44,45,53,60,93	2025 2039 2214 2261 2400 2443 2561 2767 2845 2885 2886 2887 3393 3443 3833 3910 3970 4475 4574 4577 4625 4648	bowl CP jar <i>doka</i>	UF 1 2 9 11 66 67 69 71 89 92 92C 92F 93 94 94C 110 110F 119	1017 810IW 820IY 825EBR 910 RBRIE sooty	PRO R BS B CB	HM WM CB	coarse thickening of base of cooking pot random rare fish spine impression up to 25mm lamp use
4.1	+200 (AB5)59,66 (AC5)1,99,116 (AC6)20 (AD5)67,149,167,215 287,289 (AD6)23 (BE2)1 (BE3)106 (CE5)1 (CF3)31 (CF4)21 FIE (FN6)3 (FO6)58,93,122 (FO7)77 (FP6)34,56,57,60,98,105,149,171 (FP7)10,11,19,23,84,191 (FQ3)60 (FQ4)79 (FR3)14 (FR4)9 (FZ2)1 (HA2)175 gr. 94 (JG2)- (TG5)7,74,91,95,122	300 2039 2074 2130 2339 2393 2443 2543 2625 2823 2907 3035 3207 3237 3238 3300 3339 3418 3443 3613 3716 3782 3833 4100 4363 4417 4655 4758 4809	CP jar lid? BM <i>doka</i>	1 65 67 71 89 92 92C 94C 105 110	1142 910 CRR RBRIE RBR TOP 820ER 820ECR	PRO R BS	HM	basket or mat impression

Fig.	No.	Provenance	Type	Form	Fab.	Surface & other dec.	Sherd	Man.	Comment
4.1	1000	(AB4)23 (AD5)1,49,87,154,160 (BC3)2 (BD2)26,29,94,96 (BE1)1 (BE2)1,10,11,48,57,109 (BE3)1 (BE4)14 (BF2)1 (HA2)213 gr. 218 (TG5)5/4, 73,74,86	2133 2208 2301 2312 2679 2902 2965 2975 3065 3219 3239 3245 3342 3343 3353 3239 4058	jar bowl	25 67 69 80 92 94 97	1057 820ER 820EW 820IW 820IR 822R 822W 825EBR 830IW 934E RBR	R BS H	HM WM	associated with lug scar or crocodile motif pie crust type dec
4.1	1003	(AB5)32,59,207 (BD2)28,50,100 (BD3)8 (BE1)49,73 (BE2)40 (BF1)4,6 (BF2)11,15,40 (BF3)8,38	2006 2055 2127c 2128 2192 2193 2458a 2565 2736 4263	jar basin bell jar	9 12 25 65 67 69 71 80 92 92L 94 95	1066 800E 802 820EP 820ER 820EW 820IW 822R 825EIP 825EIBL 830IW	R BS	WM HM	band of piecrust dec slip often only on prominent dec
4.1	1004	(BD2)22,26,47 (BE1)49 (BE3)1 (BE4)9 (CF4)1 (TG5)1,17	2720 2785 2793	<i>dolia</i> basin jar	1 11 65 67 94		R BS	HM WM	prominent lug in sections
4.1	1015	(BE2)52,128 (BE4)29 (BF1)73	2345	jar	67 69 94	1038 934E	R BS	HM WM	decorated lug
4.1	1016	(BE2)32 (BE3)118 (BE4)82	2277 2296		1 92	1017	R	WM HM	incised lines across body
4.1	1038	(AB4)10,11 (AC5)34 (AD5)35 (BC4)1 (BD2)28 45,71,100 (BE1)7,18,44,51,61 (BE2)70,128 (BF2)51 56 (JD2)38 gr. 40	2006 2139 2281 2312 2455 2664 2670 2716 2718 2722 2762	jar basin	1 17 65 67 69 92 94 94C	1015 820EW 820IW 822R 822W 825EIR RBR ribbed	R BS	HM WM	tripartite lug or boss
4.1	+1087	(BE3)49 (CES)1 (ZHS)14		colinder	67		BS	HM	hole D 5x3mm 12mm thick
4.1	1120	(HA2)45,52		cup	6	800E 810I	BS	HM	grooves
4.1	1128	(AD5)34	3219		65	822W	R	WM	lug
4.1	1131	(AD5)154	3343		94	820IW upper body	R	HM /SW?	lug
4.1	1140	(AD5)87	2107		92		R	WM	tool marks ext
4.1	1187	(FO6)53		<i>doka</i>	92		BS	HM	incised swirl int
4.1	1188	(FP6)57 (HA2)12		jar	6 110	812	BS	HM	basket impr/ incised
4.1	1189	(FP6)9		jar	92		BS	HM	inc lines
4.1	1194	(CE4)1		jar	110		BS	HM	basket impr
4.1	1248	(TG5)7	4605		94		B	HM	textile impression

Fig.	No.	Provenance	Type	Form	Fab.	Surface & other dec.	Sherd	Man.	Comment
4.1	1259	(FP6)137		jar	92		BS	HM	oblique grooves, scratches? tool mark?
4.1	1274	(AB5)68,91,94 (GD3)32 gr. 55	4791 4836	jar IB	1 33	820ER	R SH	WM	pie crust
4.1	3683	(TG5)29		jar	67		boss	-	
4.1	4213	(TG5)103	-	jar	-		boss	-	
4.1	4593	(CF3)49			94		lug	HM	lug
4.2	1031	(BE3)10,27 (CF3)24	2433 4418		8 67 94	1012	R	HM	rim dec
4.2	1002	(AB4)1 (AB5)92,207 (AB6)10 (AC5)37 (BD2)100 (BD3)9 (BE2)19,48,60,103,110 (BE3)27,28 (BF2)1 (BF3)7,8,9	2024 2031 2087 2127 2127b 2127d 2143 2330 2472 2527 2544 2786 3267		67 69 71 80 82 92 94	1066 1129 820IR 822R 820IW 825EW 825EIP 825ER 832R 825EIP 825EIR	R	WM HM	impressed notches on rim
4.2	1011	(BE2)110 (BF2)31 (BF3)8	2127 2170 2193		67	1012 825EIR	R	HM WM	incised ticks by rim
4.2	1017	(BE3)10,17,31,56 (BE4)82 (CE4)1,2,4,9,11,14,20,23,32,37,41,42,47,48,53,58,61,65,71,85,86 (CE5)1,4,6 (CF3)1,2,5,8,13,14,22,24,26,29,31,36,41,49,74 (CF4)1,7,10,17,18,20,26,27,31,50,59,62,65,69,74,81,84,88,93,101,102,103,107,111,113,123,128,132,133,138,139,141,145,159,161,163,165,174 (CF5)2,4 (FQ4)63 (FR4)1 (JG1)13 gr. 12,35 gr. 31 (JH3)57 gr. 36 (TG5)4/5,12	300 2022a 2022d 2025c 2029 2039 2050 2050b 2142 2214 2259 2283 2293 2296 2299 2310 2328 2329 2344 2348 2459 2767 2908 3090 3101 3420 3439 3443 3490 3689 3716 3920 4371 4441 4475 4506 4542 4562 4574 4625 4648		1 92 92F 94 105 106 110	8 1016 825ER 910	R	HM WM	impressed rim dec early Meroitic?
4.2	1032	(AC5)64 (AD5)184 (BE3)10 (BE3)16 (FP7)2 (HA2)79 gr. 188	2471 2487 3170 3399	IB	1 48 67 92C 110	820ER	R	HM	rim dec
4.2	1037	(BE2)48	2235		92		R	HM	by rim
4.2	1040	(AB5)32	2567		92	820IR	R/HS	HM	small bosses
4.2	1051	(AB5)68	2593		92		R	WM	rim dec
4.2	1063	(BD2)3	2256		94		R	WM	rim dec
4.2	1065	(BD2)28	2786		67	825IP	R	WM	rim dec
4.2	1070	(BD2)80	2766a	cup	-		BS	-	incised
4.2	1071	(BD2)89	2859		92	820EP	R	WM	incised
4.2	1085	(ZH5)2	3027		-		R	HM	incised

Fig. No.	No.	Provenance	Type	Form	Fab.	Surface & other dec.	Sherd	Man.	Comment
4.2	1093	(ZH5)36	3108?	jar	92		BS	HM	incised
4.2	1094	(CE4)2 (ZH5)37,48	3116 3128		67 94	1012 820ER	R	HM	single boss
4.2	1100	(ZH5)40	2767		92	802 as far as boss only	R	HM	double boss
4.2	1102	(TG5)1,76	2127b 2127d		92 94	825EIR 820IR	R	WM	impressed rim dec
4.2	1112	(AC5)61,79 (AD5)67 (BE2)67 (BE3)10,65,78,106 (BF2)39 (BF3)9 (CE4)11,20,85 (CE5)1 (CF3)22 (CF4)17,75,115,138 (FO6)66 (FP6)154 (FQ3)7,8,42 (HA2)54 gr. 55 (TG5)1,4,12,94 (ZH5)19	300 2022a 2025c 2050b 2039 2124b 2216 2248 2269 2340 2656 2660 2868 2893 2214 3031 3145 3398 3411 3438a 3439 3443 3497 3500 3872 4362 4371 4385 4399 4475 4500 4525 4528 4809	IB basin	1 42 67 80 92 94 110	1014 1161 1201 804E 8101 820ER 822R/BL 830IP 825ER 910 RBRIE RBRI	R	HM WM	rim dec also sometimes with lug
4.2	1121	(HA2)52,68 gr. 67	3147 3154		42 72	1115 812	R BS	HM	rim dec
4.2	1123	(FN6)3 (FS3)1	3170		92 110L		R	HM	rim dec
4.2	1139	(AD5)205,235	2073 2412	IB	69 94	RBRI RBR	R	HM	rim dec
4.2	1142	(AC5) 1,111 (AD5)224,276,283,288 (FN6)2,3 (FO6)89, 125,132,138 (FO7)1,25,73 (FP6)4,9,21,24,28,37,57,60,89,97,105,128,138,143,151,154,156,171,191 (FP7)10,34,95,150,191 (FQ3)58 (FZ2)1 (GD3)113 gr. 112 (HA1)2 gr. 1098	2295A 2410 2464 2518 2900 2990 3716 4100 4691		92 92C 110	200 910	R	HM	(AD5)224 898 227?
4.2	1143	(AC5)128 (AD5)168,293 (FO6)109 (FP6)57 (FZ2)1	2471 2910 3851 3870		92 110	805IR 820ER 910 RBRI RBRIE	R	HM	incised rim dec
4.2	1159	(FQ4)113	2967		92	825IR RBRIE	R	HM	rim dec inc
4.2	1165	(TG5)46	3980	jar	120		BS	WM	incised
4.2	1166	(FQ3)42	4062		80		R	WM	rim dec
4.2	1170	(TG5)73-87	4062		92	820ER	R	WM	r dec
4.2	1190	(CF3)2,5,13,30,31,49 (CE4)1,4,15,20,29,37,42,47,48,64,65,85 (CF4)1,7,17,35,50,51,59,67,69,75,100,108,117,132,163 (CE5)1,6 (CF5)1,2 (HA2)29 (JC3)4 (TG5)1,4, 4/5,22	2022 2022a 2022d 2025a 2025c 2340 2845 2893 2966 3038 3490 3500 3680 4377 4399 4466 4498 4535 4541 4624	bowl CP jar	56 59 67 71 92 92C 94 105 106 110 111	1164 1195 1202 1203 1212 1238 1254 820ER 820IR 820IP 822R 822P 822RH 825ER 825EIR	R PRO BS	HM	incised wavy line by rim 1 WM 1 SW
4.2	1209	(CE4)2 (CF4)30,31	3490		92 94 110		R	HM	varying number of bosses nr rim
4.2	1217	(CF3)5	3440		1		R	HM	incised by rim
4.2	1228	(CE4)9,98	4473		94 110		R	HM	gouged by rim

Fig.	No.	Provenance	Type	Form	Fab.	Surface & other dec.	Sherd	Man.	Comment
4.2	1231	(FQ3)40 (JG2)167,204 gr. 150	4494	jar	92 95	820IR	R BS	HM	incised (JG2)999
4.2	1237	(CF3)22		owl	59	810E	BS	HM	incised post firing?
4.2	1246	(TG5)7	-	-	-	-	R	-	incised
4.2	1257	(JH3)39 gr. 39	4331		106		PRO	WM	ptd r dec
4.2	1281	(BD2)46/96	2758		65	1007	R	HM	incised r dec
4.2	1294	(BE3)10	2354		25		R	HM	incised on animal appliqué?
4.3	1007	(BD2)96 (BE2)1	2758 4542		65 92	1281 822R BL TOP	R	HM	incised under r
4.3	1012	(BD3)33 (BE2)67 (BE3)10,16,18,27,104,132 (BE4)12,14,16,19,37 (BF2)31 (CE4)1 (CF3)1,24,26 (CF4)17,145,161 (TG5)18 (ZH5)15,37,45,48	2144 2170 2207 2210 2236 2238 2352 2454 2472 2860 3116 3128 3656 4350 4351 4366 4418	jar	8 12 25 61 66 67 69 92 93 94	1011 1092 1094 820ER 825ER 820EW 825I 830EY 834ER 910	R BS H B	HM WM	decorative thumb prints
4.3	1014	(BE3)78	2248		1	1112 830IP	R	HM	impressed
4.3	1030	(BE3)26	2407		67		H	HM	impressed
4.3	1069	(AD6)5		owl	65		BS	WM	inc/stamped part of an animal??
4.3	1097	(CF4)1,21,113,159 (ZH5)45	2464 2626 3152 4466	jar	67 92 94 95 110	820IR RBRI	R BS	HM	incised horiz. zigzag
4.3	1113	(HA2)54 gr. 55 (TG5)1		owl jar	42 105	804E 810I	BS	HM	rocker stamp SIM 1036
4.3	1115	(BF2)15 (HA2)52 -	2247 3147		92	1121 812			incised by rim
4.3	1119	(CF4)19 (JG2)1 (TG5)1,9	2340 2653a 4448	CP	25 92 110	1245 H805I 820IR	BS R	HM	incised
4.3	1119A	(HA2)45,52		owl	6	804E 810I	BS	HM	incised by rim
4.3	1125	(FT3)22		jar	11		BS	HM	incised pre-firing
4.3	1132	(AD5)112 (CE4)42 (CF3)2 (CF4)17 (TG5)4/5	2283	owl CP jar IB	92C 94 110	1249 820IR	R BS	HM	depressions
4.3	1136	(JE3)1	3539	jar	20		R	HM	impressed
4.3	1161	(AB4)5 (AD5)67 (FQ3)7 (TG5)91	2646 4809	jar	2 56 80 92	1112 931E 932E	R BS	WM HM	band of impressed dots
4.3	1164	(JC3)4 (TG5)22	4399		106	1190 822R	R	HM	incised

Fig. No.	Provenance	Type	Form	Fab.	Surface & other dec.	Sherd	Man.	Comment
4.3 1174	(TG5)84		jar	67	ABR	BS	WM	inc & impr
4.3 1198	(CF4)1	4361		2		H	HM	stamped
4.3 1201	(CE5)1	4362		1	1112	R	HM	inc band nr rim
4.3 1205	(CF3)1		jar	92	820EP	BS	HM	incised pattern
4.3 1216	(CE4)20 (CF3)5	3679		2 110	822R	R	HM	incised band
4.3 1227	(CE4)42	4458		92		R	HM	incised
4.3 1229	(CF4)113	3446		94		R	HM	gouged rice grain pattern
4.3 1242	(CF4)142,162	4350		92	BOSS	R	HM	gouges 898
4.3 1249	(TG5)5/4	4611	IB	92	V1132	BS	HM	incised
4.3 1265	(JD2)49		CP	92C		BS	HM	inc v lines
4.4 +1001	(BE2)1	2030		1	31g 810E	R	HM	scarab appl
4.4 1006	(BE3)1	2094		65	830IR	R	HM	appliqué frag
4.4 1019	(BE2)105		jar	67	873E	BS	WM	moulding
4.4 1066	(AB4)23 (AB5)59,92 (AC5)77 (AD6)19 (BD2)71 (TG5)1	2128 2458a 2786 2853 3756a 3763		12 67 92 110	1002 1003 1068 820EW RBR RBRIE	R PRO	HM WM	snake or crocodile appl. fragment
4.4 1068	(AB4)23 (AC6)22	2128 2828		67	1066 RBR	R	HM	appliqué
4.4 1082	(AB4)23 (AD5)115,178	2550 2725 2765 2995 3332 3359	coarse lid	67 71 91C 92 92C 94C		PRO	HM SW	brick, lid score
4.4 1083	(AB5)89,229		bowl	69	825ER	BS	HM?	appliqué 898?
4.4 1129	(AC5)37,45	3267		92	1002 RBR TOP	R	HM	999 appliqué animals
4.4 1133	(AD5)112	3389	lid?	67	825EP	H	HM	snake appliqué
4.4 1141	(FS3)6		bowl	92C	825IW	BS	HM	scalloped
4.4 1141b	(AD6)16 (FO6)114 (FR3)14		CP	110		BS	HM	scalloped
4.4 1195	(CF4)1	3490	jar	67 110 111	1190 820IR	R	HM	incised lines
4.4 1202	(CF3)1,31 (CF4)62,163 (CE4)85	2025C 2022d 2340 2845 4399	bowl	92 106 110	1190 820IR	R	HM	incised lines near rim
4.4 1203	(CF3)1 (TG5)1	2025c 2340	jar	110	1190 820IP	R BS	HM	incised lines
4.4 1212	(CE4)9,14,20,42,47,61 (CF3)1,13,17,22 (CF4)7,17,35,36,50,51,128,155,163 (TG5)4	2022a 2025a 2025c 3038 3490 4377 4399 4417	jar bowl	67 92 92C 94 105 110	1190 820IR 820ER 825ER RBR TOP	R BS	HM	incised criss-crossed lines
4.4 1238	(CE4)65	4535		94	1190 820IR	PRO	HM	incised
4.4 1254	(CF4)117	4624		110	1190 H820IR	PRO	HM	incised lines

Fig. No.	Provenance	Type	Form	Fab.	Surface & other dec.	Sherd	Man.	Comment
4.4 1288	(FT3)10	2025c		110	1190	R	WM	incised
4.5 1036	(BF1)56 (FT3)2 (GD3)44	2132 3440	bowl	11 42 45	812	R BS	HM	rocker stamp
4.5 1056	(AB4)1,6,20,22 (BD2)23	2653 2653b	bowl cup	92	800E 802	R BS	HM	impressed dec
4.5 1058	(AB4)6	2653		92	800E	R	HM	impressed
4.5 1114	(HA2)52 -	3146		42		R	HM	neol comb dotted
4.5 1117	(HA2)60 gr. 58		bowl	5		BS	HM	Neolithic rou- letted?
4.5 1118	(CF4)1 (CF5)1 (HA2)25 gr. 23		bowl jar	6 8 11	800E 810E 810I	BS	HM	roulette
4.5 1122	(FT3)1		bowl	11		BS	HM	incised Meroitic?
4.5 +1155	(AB4)23 (FQ/R4)2 (TG5)18	2959 3612 3908		1 92	1081 800E 9611	R	HM	impr Meroitic?
4.5 1191	(CE4)1		jar	67	820IR	BS	HM	incised,impr
4.5 1192	(CE4)1	3527	jar	92	810I	R	HM	impr Mer
4.5 1193	(CE4)1 (CF4)1		jar	11		BS	HM	impr dots
4.5 1197	(CF4)1		jar	11		BS	HM	impr dots Mer
4.5 1199	(CE5)1		jar	2	810E	BS	HM	impr & rocker stamp Meroitic
4.5 1200	(CE5)1	4363		1	800E	R	HM	impressed
4.5 1207	(CF5)1		bowl	6	810E	BS	HM	incised white infill
4.5 1208	(CF5)1 (TG5)1		bowl jar	8 59	805EI	BS	HM	impressed large dots
4.5 1210	(CE4)4,71	2045 4375		8 106	810E 822R	R	HM	impressed large dots
4.5 1218	(CF3)5	3440		1	1217 812	R	HM	rouletted
4.5 1221	(CF3)1	4396		59		R	HM	impressed dots
4.5 1222	561 8 (CF4)26 (JG2)265,202,242,266 gr. 175	3440 4440	bowl	7 59 106	1036 1217 1218 1226	PRO BS	HM	impressed dots - rocker stamp
4.5 1225	(CF3)24 (TG5)12		bowl	42 63 131	800E 812	BS	HM	rocker stamp Neolithic?
4.5 1226	(JG2)202,242,265,266 gr. 175 (TG5)4	4440 4455		92 106	1222	PRO R	HM	impressed dots
4.5 1230	(CF4)113		jar	94	960I	BS	HM	impressed dots
4.5 1234	(JC3)6	4512		1	805E	H	HM	impressed dots, rocker?
4.5 1235	(CE4)71		-	-		BS	HM	rouletted

Fig. No.	Provenance	Type	Form	Fab.	Surface & other dec.	Sherd	Man.	Comment
4.5 1236	(CE5)6		owl	6	810E	BS		impressed comb impr
4.5 1240	(CE4)48	4545		92	812	R	HM	impr Merotic
4.5 1244	(CF4)104		owl	106	800E	BS	HM	impr dots
4.5 1245	(TG5)1	2653a		92	1119 H805I	R	HM	inc
4.5 1255	(FP6)89		jar	94		BS	HM	inc line impr dots
4.5 1260	(FP7)60		jar	11		BS	HM	incised impr Kerma?
4.5 1275	(GD3)0		jar	92	805E	BS	HM	inc impressed
4.5 1284	(JC3)6 -	4824	cal bkr	8		R BS	HM	inc impr Neol?
4.5 1034	(BE3)16	2025b		50	810	R	HM	Merotic impressed
4.5 1184	(JH4)1 gr. 1	4336		11	810E	SH	HM	impressed
4.5 1185								
4.5 1186								
4.5 1180								
4.5 1181	(JH3)76 gr. 21	4335	BJ	8	810E	PRO	HM	impressed
4.5 1182								
4.5 1183								
4.6 +1081	(AB4)23	2959		1	1155 800E	R	HM	ptd w slip
4.6 1095	(ZH5)38		jar	92		BS	HM	inc and punctated
4.6 1099	(ZH5)38		jar	92		BS	HM	inc and ptd
4.6 1160	(FQ4)37		owl	110		BS	HM	random pt dribble?
4.6 1163	(TG5)69			-				inc impr
4.6 1204	(AD5)1 (CE4)2 (CF3)1,8,11,24 (CF4)18,20,62,81,88,99 (CF5)1 (FP7)2 (FT3)22 (JG1)-(TG5)1,75	2021 2022a 2025c 2039 2169 2564 2742 3189 3490 4302 4365 4399 4400 4831	owl jar CP	11 67 69 80 92 92C 94 110 110C	1219 820IP 820IR 820IW 825IW 820EW 822P 820ER 825EIR 825EW WRBRIE	R BS	HM SW WM	white infill white band by rim
4.6 1219	(CF4)20,62,132	2022a 2025c	owl	92 92C 110	1204 1233 822P 825EIR	R BS	HM	white pattern on pink slip, white infill
4.6 1232	(CF4)107		owl	27/65	820EW	BS	HM	inc line & impr dots

Fig. No.	Provenance	Type	Form	Fab.	Surface & other dec.	Sherd	Man.	Comment
4.6 1233	(CF4)132 (HA2)146 gr. 94	2022a 4375		92 63	1219 850 x 2 822P	R	HM	incised
4.6 1252	(TG5)4	2025c		106	822R	R	HM	inc triangle with dots
4.6 1295	(BF1)72 (TG5)5/4	2757 4611		1 92	1112 1132 1249	PRO	HM	punctated
4.7 +1054	(AB5)66		closed jar	69	825EIW 820EP	BS	WM	painted pink slip
4.7 1162	(TG5)64			-		BS	WM	ptd
4.7 1167	(FO6)37	3831 3843		110	I & E	R	HM	dribbles?
4.7 1178	(JG2)4	3699		139	820EO	R	WM	stamped
4.7 +1179	(JE3)0		cup	139		BS	WM	stamped
4.7 1263	(JF2)36,51 gr. 55	4764	cup	26	RBRE	R BS	WM	stamp 999
4.7 1272	(GD3)70a gr. 45	4785	cup	26		PRO	WM	ptd floral
4.7 1273	(GD3)1	4788		26		R	WM	ptd lotus flower
4.7 1277	(GD3)1		cup	26		BS	WM	stamped
4.7 +1278	Q3 Locus 31368		cup	26	SA?	BS	WM	stamped
4.7 +1279	(GD3)32 gr. 55 (TG5)91		jug	26	BL & R	BS	WM	ptd floral
4.7 1285	(TG5)17		cup	26		BS	WM	stamped
4.7 +1289	(JH3)44,67 gr. 43,130 gr. 116	3694 3695 4329		34 132	1291	PRO	WM	ptd, Merotic
4.7 +1290	(JH3)130 gr. 116	4329		132	1289	PRO	WM	ptd, Merotic
4.7 1291	(JH3)44,67 gr. 43	3694 3695		34 132	1289 820ER	R	WM	ptd, Merotic
4.7 +1292	(JH3)130 gr. 116	4326		132	134g 820EO	PRO	WM	ptd, Merotic
4.7 1270	(GD3)70a gr. 45	4785	cup	26		PRO	WM	1270 <i>ankh</i> int white
4.8 1124	(FT3)22	3187		2	820EY	R	HM	crimped rim
4.8 1156	(FQ4)7	3916	jar	92	820EW	SH	WM	ptd indistinct
4.8 1169	(TG5)73-91			76L		BS	WM	obl ptd lines
4.8 +1173	(JH3)57 gr. 56 R18 -	2881	jar	120 132	820EO	N BS	WM	ptd Plate 4.3
4.8 1175	(TG5)79		jar	-	ABR INT	BS	WM	ptd
4.8 1177	(TG5)75	4304		94		R	WM	ptd
4.8 1213	(CF3)13		jar	130	820EO	BS	WM	ptd
4.8 1215	(CF4)17		jar	130	820EO	BS	WM	ptd
4.8 1220	(CE4)23 (CF3)2,8,22,29 (CF4)132 (CF5)4 (TG5)5/4	4496	jar bowl	67 94	820EO 820EY 820EYCR 820IIV 825EW 830EB 833EBR	R BS SH	WM	painted triangle with criss-cross lines (CF5)5 898 (CF3)8
4.8 1223	(CF3)11 (TG5)4		jar	80 94L	820ER 820EY	BS	WM	ptd
4.8 1239	(CF4)69		jar		820ER	BS	WM	ptd floral
4.8 1241	(CE4)48	4555		130	825ER	H	WM	ptd

Fig. No.	Provenance	Type	Form	Fab.	Surface & other dec.	Sherd	Man.	Comment
4.8 1243	(CF3)2		jar	94	822CR	BS	WM	ptd bands
4.8 1247	(TG5)7		jar	94	820IY 820ECR	BS	WM	ptd bands
4.8 1250	(TG5)5/4		jar	94	822Y	BS	WM	ptd geometric
4.8 1251	(TG5)4		jar	94L	820EY	BS	WM	ptd bands
4.8 1253	(TG5)4	4617		92	825EP	H	WM	ptd
4.8 1256	(FP6)89		jar	94	822R	BS	WM	ptd
4.8 1262	(JF2)36 -		jar	132		BS	WM	ptd
4.8 1264	(JD2)43,51 gr. 40		BJ	132	820EBR	BS	WM	ptd 999
4.8 1266	(JD2)51 gr. 40		jar	132	820EO	SH	WM	ptd bands
4.8 +1283	JF1 26 gr. 23		BJ	105	820EO	SH	WM	ptd
4.8 1293	(JH3)39 gr. 39			139	820ER	PRO	WM	ptd floral
4.9 1135	(JE3)10 gr. 115	4333	jar	100	820ER	BS	WM	ptd
4.9 1206	(CE4)14,37 (CF3)1 (CF4)17 (JG2)180 gr. 150		jar	93 94 94L 106 132	810E 825EO 830EO	BS	WM	ptd floral pattern
4.9 1211	(CE4)4		jar	-		BS	WM	ptd
4.9 1214	(CF4)17		jar	-		BS	WM	ptd
4.9 1276	(GD3)147C gr. 20	4804	BJ	94L	820ER	PRO	WM	ptd floral
4.9 +1282	(JG2)180		BJ	65	820EO	BS	WM	ptd bands BR & Y
4.9 1286	(CE4)2	4810		80		BS	WM	ptd
+ 1057	(AB4)6,11,23		jar	65 67	1000 825EIW	BS	WM	paint splodges Plate 4.2
+ 1146	(CE4)1 (JE3)2		jar	92 118	820ER 830EY	BS	WM	ptd swirling band Plate 4.3
+ 1148	(JE3)26 gr. 115		jar	106		BS	WM	ptd Plate 4.3
+ 1261	(JF2)23 gr. 20		jar	118	820EO	BS	WM	ptd Plate 4.3
+ 1296	(CE4)42	stirrup cup	<i>askos</i> SH	AEG	R/BR/R	BS	WM	ptd Plate 4.3

5. The Graffiti and Pot Marks

Potter's marks, owner's marks and a range of symbols are included within the classification 'graffiti', as are some possibly accidental scratches. They occur on a wide range of forms in both the Napatan and Meroitic periods. In Figures 5.1-5.11 these have been arranged according to similarity of design, rather than chronologically or by the type of vessel they occur on, in order to aid the recognition of fragmentary marks. Information on the form, fabric and context can be found in Table 5.1, and any known parallels are listed in the discussion below.

'Graffiti' is here taken to mean anything that has been incised on a vessel after firing, either a symbol, a pictogram or letters/hieroglyphs, but included are also marks (excluding what are deemed to be decorative patterns, for which see Chapter 4) that were incised before firing, in which case they are more likely to be potters' marks. The post-firing marks may denote ownership or relate to the contents of the vessel (especially in the case of storage or transport containers), but may also illustrate a concept – good fortune, or to ward off evil, for example. Graffiti are more common on wheel-made than handmade vessels (c. 65-35%), and most common of all on Napatan amphorae. Whether any of the graffiti on these vessels were added before arrival at Kawa or after is an open question, but where a similar symbol occurs on both local and imported vessels, the probability is that it was added at Kawa. However, in trying to decipher these marks we should consider that the opposite is also possible, i.e. that symbols from 'abroad' inspired the local population to adopt them, whether with the original meaning or not.

While the graffiti on imported vessels include some of the symbols used on local vessels, and vice versa, some are found exclusively on one type only.

While the intention has been to reproduce the marks as they would have been oriented with the vessel standing upright, especially in the case of handmade sherds this alignment may not always have been identified correctly. Equally, a few marks are drawn upside down (or at any rate in a different orientation) on vessels whose rim survives (cf. e.g. 34g, 80g and 200g, 5.1).¹

As a group the Napatan amphorae are interesting as they are so similar in terms of form and function (discussed in more detail in Chapters 3.1 and 6). A grid symbol is the most prevalent; it is tempting to suggest that it was part of a recording system – the time of production or filling of the vessel, or the rate of removing the contents, whether through sale or donation or simply daily consumption; however no marks have been found within the grid squares. On some examples the uppermost horizontal line has a kink in it that brings to mind the head of a camel (e.g. 183g and especially 205g, Figure 5.7), with the rest of the grid making up the body, perhaps a reference to the mode of transport of the vessel. Note a variant in Vincentelli 2018b, pl. 1.5, where instead of a 'camel head' there are several radiating lines,

¹ This symbol/letter also occurs as a mason's mark on two blocks from the Great Enclosure at Musawwarat es-Sufra (Wenig 2019, 855 fig. 8), but the later date (3rd century BC) means that they cannot bear a direct connection to the graffiti at Kawa.

bringing to mind a flail (*nekhakha*). The size of the grid, if it bears a relationship to the volume and contents, might be expected to vary depending on the size of vessel, especially if it is larger (such as the forms in 3.1.8), but on the contrary, 133g is a small and neat grid with only four boxes, whereas some of the grids on the more common medium-sized amphorae are often larger and have six boxes.

There is a range of other symbols, possibly denoting ownership (?) or relating to the contents. These include palm branches (196g, 199g),² birds (204g, 217g), and 'letters', (which for the sake of convenience will be referred to here by their Greek names where there is enough similarity) such as 200g, 219g (*alpha*); 186g and 187g (upside down *rho*, for example); 75g (*psilon*). 265g may represent a sceptre (?), and thus falls within a Kushite repertoire of symbols. Again, it is unclear whether these illustrate a concept (good luck, for example) or ownership or perhaps the provenance of the contents. Or, indeed, if they are simply the bored doodles of the caretaker of a storeroom.

Of indisputably Meroitic date are the two texts 134g and 135g, and a single letter/hieroglyph, 163g.

Apart from seeking parallels incised on pots at other sites in Kush, it is noteworthy that a few of the symbols also occur as petroglyphs. In the context of rock art the same symbol could also be interpreted to be a mark of ownership, so it does not rule out this explanation for the pot marks, but it does offer up further possibilities in interpretation, as well as in helping to date the rock art. Often the marks in question are not part of the main scene recorded and thus have been ignored to some extent. See for example a section of the walls of the Great Enclosure at Musawwarat es-Sufra, where a glyph very similar to 157g and 160g is found, thought to present a variant of an offering table (Kleinitz 2009, fig. 16). Kleinitz herself also highlights the petroglyph-graffiti on objects nexus (*ibid*, 179-198).

A Carian connection?

A number of graffiti bear a resemblance to letters of the Carian alphabet. Admittedly, when perusing other ancient alphabets (Uartian or Tifinagh, for example)³ these also contain similarities, but with a Carian presence well documented in Egypt and in Lower Nubia, this is intriguing, as it fits chronologically (7th and 6th centuries BC) with the vessels on which the symbols/letters are found. At Kawa some occur on imported vessels while others have been inscribed on locally-made bowls. See for example Masson 1978, figs 1-3, for tables illustrating the Carian alphabet and the variations between inscriptions found in Caria and at Memphis or Saqqara. The references here to the Carian alphabet refer to the tables presented by Masson, where the varia-

² Note a similar motif on building blocks probably to be associated with Pyramid S5 in the cemetery (Welsby and Taylor forth., cat. no. F-2467 and perhaps cat. no. F-2465).

³ For that matter, parallels for the pot marks and graffiti can also be found elsewhere, without having a related meaning; see for example Anatolian Late Bronze Age pot marks (Glatz 2012, fig. 2).

tions and development of Carian letters is traced from Asia Minor to Egypt (Masson 1978, figs 1-3; this publication is that referred to below). These include 34g, 80g, 200g and 219g (*alpha*) for fig. 1.1; 186g and 187g for fig. 1.15; 56g, 104g, 156g, 167g and 1152g for fig. 1.22 (*psi*); 53g, 203g and 243g for fig. 1.33; 38g, 41g and 157g for fig. 1.9, and 36g for fig. 1.28. What meaning these marks have is open to further research. One possibility is that they are actually numbers (quantities?), as letters in Hellenic alphabets were also used to represent numerals. *Alpha*, for example, is 1, *psi* 700. 207g and 264g vaguely resemble *sampi* (value: 900). What the ‘numbers’ would refer to is another matter, but it is unlikely to be volume as the amphorae they occur on are of almost identical size. These possibilities are voiced here as mere observations, worth considering but by no means proven.

Tituli picti

The four instances found at Kawa, all from Building F1, are not totally convincing, in particular 232g, 233g (5.3) and 234 (5.5). These three may simply be the result of the vessel coming into contact with the oily substance that has stained so many sherds in the building, leaving a discolouration that accidentally appears to be deliberate. On the other hand, 230g (5.5) does appear credible. For a more convincing example than those shown here, but also on a Napatan amphora, see Vincentelli 2018, pl. 8 (drawn with ink of some kind). In comparison the Kawa examples are, if intentional, very basic pot marks indeed.

Interestingly, graffiti/pot marks at Hillat el-Arab are as a rule found under the level of the handles, while at Kawa they are almost always found between the shoulder and the lower limit of the handles (cf. Vincentelli 2006, *passim*).

Discussion of the graffiti and other marks

5.1. Symbols and/or ‘Greek’, or Carian, letters

A variant of 56g and 161g is found on an Egyptian wine jar from the Early Dynastic Period, according to the museum database (Medelhavsmuseet Stockholm, acc. no. MM 18604); however, cf. Aston 2003, fig. 10.807-811 (after Petrie 1909), where the same type of jar is dated to the late 7th-6th centuries BC, with some of the vessels bearing the same pot mark. Clearly this is a symbol that was either long-lived or that was reinvented in different periods and cultures, as it also figures in the Carian alphabet. 75g, found on a Napatan amphora made of Nile clay in Building A2, belongs to this range of symbols/letters.

113g: Dunham 1965, 140, 144, Group V, from Nu.1 (5, 690-664 BC) fig. 4, 16-12-17, the form similar to 3368x (3.6.5). Dunham suggests it may be of later date (Christian), but the similarity to the present specimen suggests it may well be Napatan.

161g: Dunham 1965, 133, Group I.2 (Kerma-Middle Kingdom) but likely to be of Napatan date in this instance.

200g (and 34g, 80g, 219g): Nu. 36 17-2-52. A dropped-bar alpha.

265g: A was-sceptre?

5.2. Other letters and/or symbols (cont.)

37g and 66g: Albeit both of these are fragmentary, cf. Vincentelli 2006, fig. 2.74 for a pot mark on body sherd 460, dated to the 19th-20th Dynasties.

53g (also 203g and 243g): Laming Macadam 1955, II, pl. LXVI.g No. 199: an *ankh* (on the left) and a symbol akin to 53g, on a loose sandstone block from Temple T.

67g: The central symbol bears a close resemblance to one of the petroglyphs from the Selima oasis (Jesse *et al.* 2015, pl. 10).

91g and 179g: There is a remarkable similarity between these two items, the former incised on a Napatan amphora of Fabric 113, the latter on a bowl (4559x, 3.8.10) in Fabric 110. They bear a resemblance to the text on a small sandstone altar, found built into a late Meroitic wall at Kawa in the course of Kirwan’s excavations, although the middle symbol is admittedly difficult to equate with the *ankh* in the earlier Kawa publication (Laming Macadam 1955, II, pl. XXXIII [2189]). Unfortunately the ‘brackets’ on either side of the *ankh* are merely described as ‘symbols’, rather than identified (Kirwan 1955, 231).

125g: For a similar graffito, but with a long line extending from the apex of the triangle, see Vincentelli 2006, fig. 2.47 290, Hillat el-Arab tomb ARA 13; the tomb is thought to date to the Third Intermediate Period, with reuse in the 25th Dynasty.

186g, 187g and possibly 138g: For similarity to a Carian letter, see Masson 1978, fig. 2.15.

203g: Around the graffito there is the hint of a faintly incised circle, done most likely while the clay was still wet. On the same vessel (Napatan amphora 4658x, same form as 4755x, 3.1.6) there was a fragmentary graffito resembling a hooked staff, similar to the upper half of 260g (5.5), but it was not drawn or photographed.

5.3. Further letters and/or symbols (cont.)

165g and 214g: A similar mark occurs on a pot sherd reused as a weight at Jebel Barkal (MFA photo, Barkal 16 3 128).

175g: Given the similarity between this and some of the other graffiti at the bottom of this figure and some of the birds (Figure 5.11) it is possible that these incomplete marks are also part of birds.

241g: Vincentelli 2006, fig. 2.71 455, Hillat el-Arab tomb ARA 16, mark made before firing; for further discussion on the date, cf. G6.

5.4. Napatan and Meroitic graffiti and symbols

36g: An offering table with four bread loaves(?), unevenly distributed.

62g: Note especially the similarity of composition to 151g – deriving from a common system or idea?

101g: Beg. S.207, but there on a pilgrim bottle. Also Bates and Dunham 1927, pl. LXII fig. 28 U32/4. Vincentelli 2006, fig. 2.93 amphora 597 from Hillat el-Arab tomb ARA 19, (dated to 1000-700 BC).

134g and 135g: Drawings and photos of the two texts were sent to Claude Rilly in 2011. Very kindly he has now (2021) updated his earlier comments as follows:

Comments about the Meroitic inscriptions engraved on the jars from Kawa

“I am not certain about the reading of some characters. In the first graffito, the rotundity of the jar partially hides the first sign. In the second graffito, the second group of two signs is ambiguous: if it is ‘*ni*’, a second vertical stroke is missing, but the ‘*n*’ is quite recognizable; if it is ‘*ki*’, all the elements are in place but the ‘*k*’ is surprisingly close to the ‘*i*’.

The inscriptions are very early and can be compared with temple graffiti from Kawa or early texts from Meroe. They can be dated to the second century BC (Rilly 2007, 346, Table 12, ‘Archaic A’). Therefore, the date given for the jars on ceramological bases are confirmed by palaeography. These two texts fall into the category of the so-called ‘inscriptions of property’ (Rilly 2007, 205-207) which I would now call with more accuracy ‘inscriptions of dedication’ (Rilly 2011, 491-493). They include a personal name or a title followed by the sequence *-s-o*, which in the funerary context means ‘it is from’ (and not as formerly translated, ‘it is of’, ‘it belongs to’).

The first graffito (134g, 4326x) probably read *weredoke-li-s-o* ‘it is from Weredokeli’ or ‘from the great *were*’ (a title?). The presence of the article *-li* may indicate a noun (a title in this case) or a personal name with a determiner (cf. French names such as ‘Legrand’ or ‘Leblanc’). A title ‘*were*’ is so far not attested, but new titles are discovered nearly every year, especially in Sedeinga and Sai.

The second graffito (135g, 4330x) reads ‘*arxsiki-s-o*’ or ‘*arxsini-s-o*’. This time, the absence of an article shows that we are dealing with a personal name, Arakhasiki or Arakhasini.”

Claude Rilly

151g: Bates and Dunham 1927, pl. LXII fig. 29, Gemai Gr. 119 R1, on a large tubular jar like 3538x (2.8). In this instance the symbol is painted on, but no interpretation of the meaning is given.

155g: Griffith 1924, pl. LXXII.3, note the two cross lines, although in 155g the line above is curving rather than straight.

163g: Meroitic hieroglyph. Griffith 1924, pl. LXXII.5; Laming Macadam 1955, I, 161 fig. 53 [0472] and Beg. W.21 fig. D, 15 22-1-629c. Of all the letters/hieroglyphs in the Meroitic alphabet, this is the one that occurs most commonly on vessels. Also occurs as a petroglyph/part of an inscription, Redford and Redford 1989, figs 81 & 82 (Eastern Desert). Also occurring individually, cf. Kleinitz 2009, fig. 15 (Musawwarat es-Sufra).

181g: Dunham 1965, group III.6

1116gi: A mark incised near the base on the interior of bowl 3149x; a similar mark, also on the interior, but dot-impressed was found on a Meroitic (?) incense burner at Gala Abu Ahmed (Jesse and Kuper 2006, pl. V).

5.5. Linear symbols, tituli picti, and potter’s marks

114g: Possibly represents a palm branch.

168g: A similar kind of mark is found on pottery from the late Middle Kingdom at Kahun (Gallorini 2009, fig. 5.1): not of direct relevance here, but nonetheless shows a system where such marks were used.

176g: Possibly a potter’s mark.

1009g: Gouged after firing.

1089g: Inscribed near the rim before firing, this is most likely a Meroitic hieroglyph (cf. Laming Macadam 1955, I, 115).

5.6. Graffiti of the ‘grid’ type on Napatan amphorae in particular

A pot mark made before firing was found at Hillat el-Arab on an amphora thought to date to the 20th Dynasty (Vincentelli 2006, fig. 2.71 455, tomb ARA 16). The rim is missing, but the body looks similar to amphorae of early Napatan date (Vincentelli 2006, fig. 2.94 599, tomb ARA 19). These grids have also been noted at Sanam Abu Dom (Vincentelli 2018b, 180, fig. 3.1 and 3.3, also pl. 1.5).

100g: Notches cut across the rim, with an extra oblique line that is presumably part of a design/pictogram.

133g: A typical grid graffito, like on so many Napatan amphora. Note that there was a second graffito on the same vessel, most likely also a grid. Not drawn, but see photograph, (133g (1), Plate 5.2).

226g: Unlikely to have a connection with the practice of rim notches.

1138g: Grooves cut in the rim post firing, but intriguing as the vessel form (bowl 3425x, 3.8.18) is so different from the amphorae where this phenomenon usually occurs. In that instance the notches are thought to be cut for a practical reason, to facilitate the removal of stoppers.

5.7. Further variations of the grid motif on Napatan amphorae

189g and all other graffiti on this page: Nu.23 (9, 623-593 BC) fig. 48, 17-3-492; Vincentelli 2018b, fig. 3.1 (the parallels both have the top line curving up on the left, rather than being an extension of the right-hand corner – proof of right- and left-handedness in the early Kushite period?).

205g: The angled uppermost line gives the symbol as a whole the appearance of having a neck, suggesting a possible reference to a camel.

5.8. Variations of the grid motif and more freestyle designs

Note a similarity between the more complex (?) graffiti (143g, 225g and 242g) with a petroglyph recorded by Redford and Redford (1989, 15 figs 17 & 18) and ascribed by the authors (erroneously, if it is part of this type of mark) a Coptic date.

143g and **144g:** A similar but incomplete graffito on an

amphora of different type, 599 in tomb ARA 19 at Hillat el-Arab (Vincentelli 2006, fig. 2.94) The parallel is cautiously dated to the Libyan Period (1000-700 BC).

225g: Variant of graffito on a similar amphora in Nu.28 (11? 568-563 BC) north-east foundation deposit, fig. 95, 17-4-1223.

250g: The lower left part of this graffito is reminiscent of the pot mark on a jar found in tomb ARA 19 at Hillat el-Arab (Vincentelli 2006, fig. 2.97).

5.9. *Random (?) scratches and rectangular motifs*

The drawings on the upper half of the page appear to be random scratches on vessels.

166g and 193g: these are the only two examples of what may be graffiti on *ostraca*.

244g: Drawn with charcoal. It is possible that this could be accidental, a discolouration made by root tendrils or similar.

5.10. *Particularly fragmentary marks*

These are so fragmentary that it is hazardous to suggest an interpretation. They are in some instances (top row) likely to be part of the 'grid' graffiti (see Figures 5.6 & 5.7).

5.11. *Animals in the graffiti and composite scenes*

Birds are by far the most common animal to be incised, both pre- and post-firing, although an ostrich is the only species that can confidently be identified. One example of a rearing horse (?) was found on a Meroitic (?) handmade jar. The 'camel' represented by 205g has already been discussed above (5.7).

204g: The only bird incised on a Napatan amphora (4666x, 3.1.6); a duck was found on an almost identical form at Sanam Abu Dom (Vincentelli 2018b, 180, fig. 3.5).

266g: The fragmentary depiction of a bird, incised near the base of a bread cone, found on the surface near trench

(TG5).

1287g: Series of three incised birds and two other symbols, on 4834x, an unfired bowl (3.11.9). Bird motifs are popular on Kushite pottery, (e.g. Török 1987, figs 59-61 [Meroitic]); see also the other incised birds in Figure 5.11. In the present case, however, the birds are clearly intended as decoration rather than graffiti, but in view of their similarity (crude execution, for one) to the *bona fide* graffiti it seemed more apposite to include them here. The two symbols (?) between birds one and two, looking at the drawing from left to right, are also intriguing. The one on the left consists of two lines linked by a roughly horizontal line, reminiscent of a capital H while the one on the right looks like a butterfly (or snail?) facing bird two. No clear interpretation of the meaning suggests itself. Interestingly, it looks as if there originally was a fourth bird to the right of the "H" symbol that was then erased and the 'butterfly' inserted: the latter is in fact drawn in the unfired clay when it was drier – note the more fluid lines of the birds (Plate 5.1, 1287g, elements b & c).

A number of the amphorae have multiple symbols incised, which, from the depth of the lines and degree of wear appear to have been made at the same time, rather than added to over time. These include amphora 4665x (3.1.5, illustrated in Section 6) with symbols, 183g (grid), 186g and 187g, identical to each other and placed flanking 183g but on different sides of the vessel; 198g-200g (a square around the handle, a palm leaf and an 'A') on 4662x; on 4685x, 217g (ostrich), 219g ('A') and 265g (*was-sceptre*). On yet another Napatan amphora, 2826x, 60ga (two grids) and 60gb (two vertical lines with oblique cross-bars) are incised next to each other. These types of graffiti also occur on their own, suggesting that the more complex arrangements add further information. The meaning of 240g and 241g, either separately or in combination, is unclear, but the similarity of 240g and 248g (both incised on Napatan amphorae, but made of different fabrics and found in different areas of the site) strongly suggests that at least 240g had a more general meaning, beyond the strictly personal. The significance of the juxtaposition of 190g and 261g, both fragmentary, on the same amphora shoulder is even more obscure – 190g is reminiscent of part of 250g (5.8) while 261g may be part of a grid graffiti.



Plate 5.1. Detail of 1287g on bowl 4834x. Note faint outline of a bird's head to the right of the 'H', and the less fluid lines of the butterfly/snail.

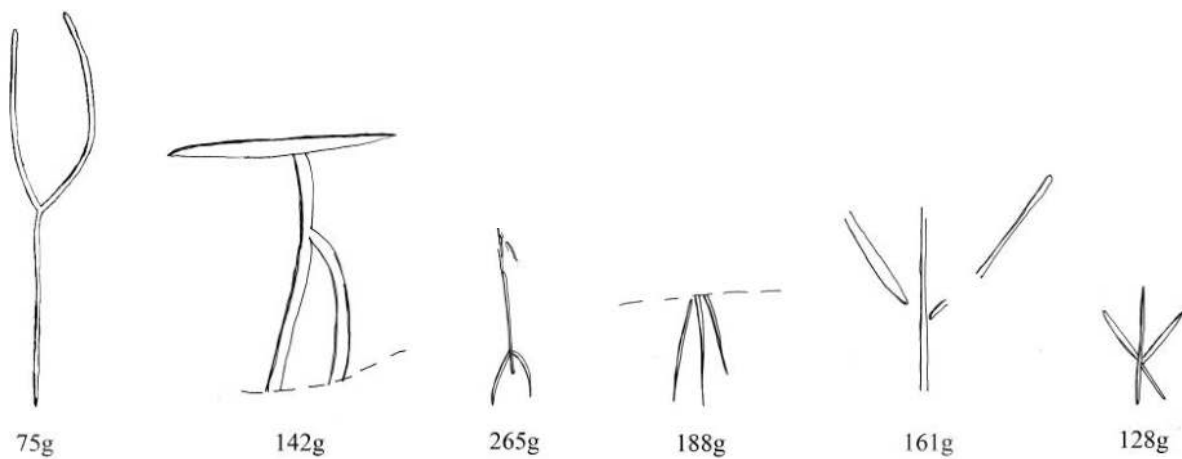
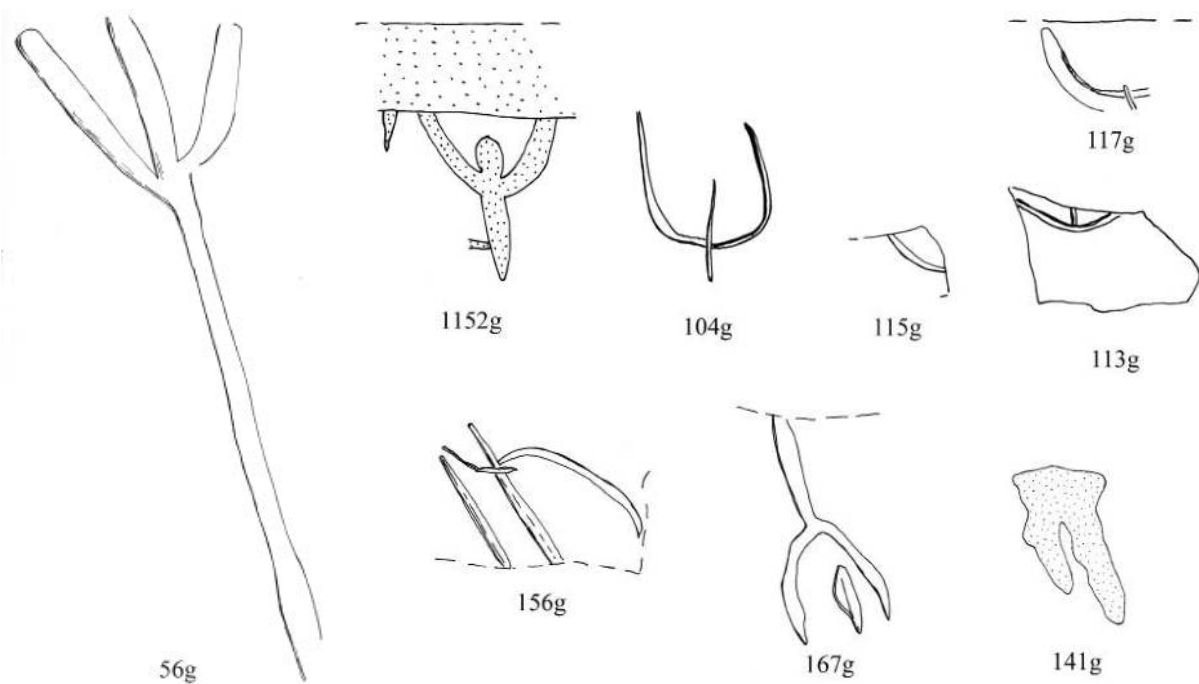
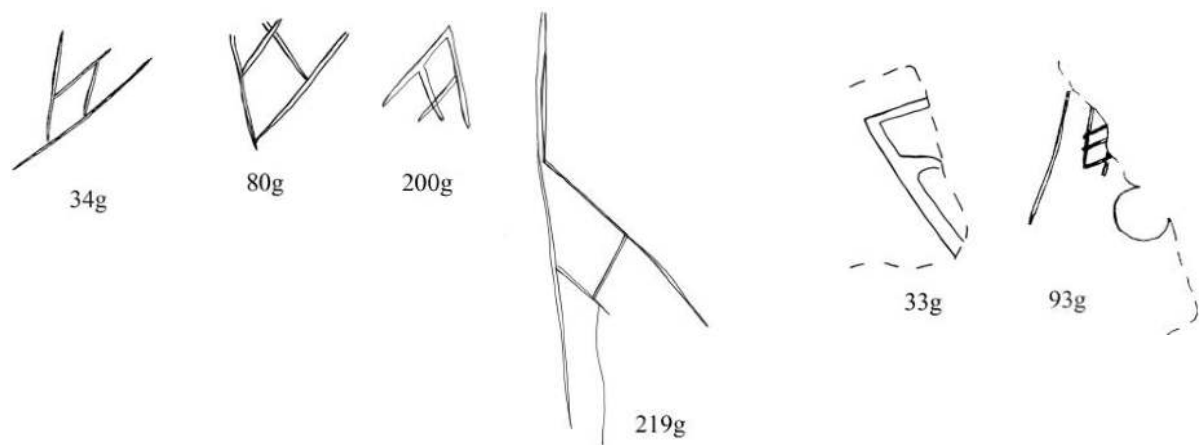

Figure 5.1. Symbols and/or 'Greek' (?) letters (scale 1:2).

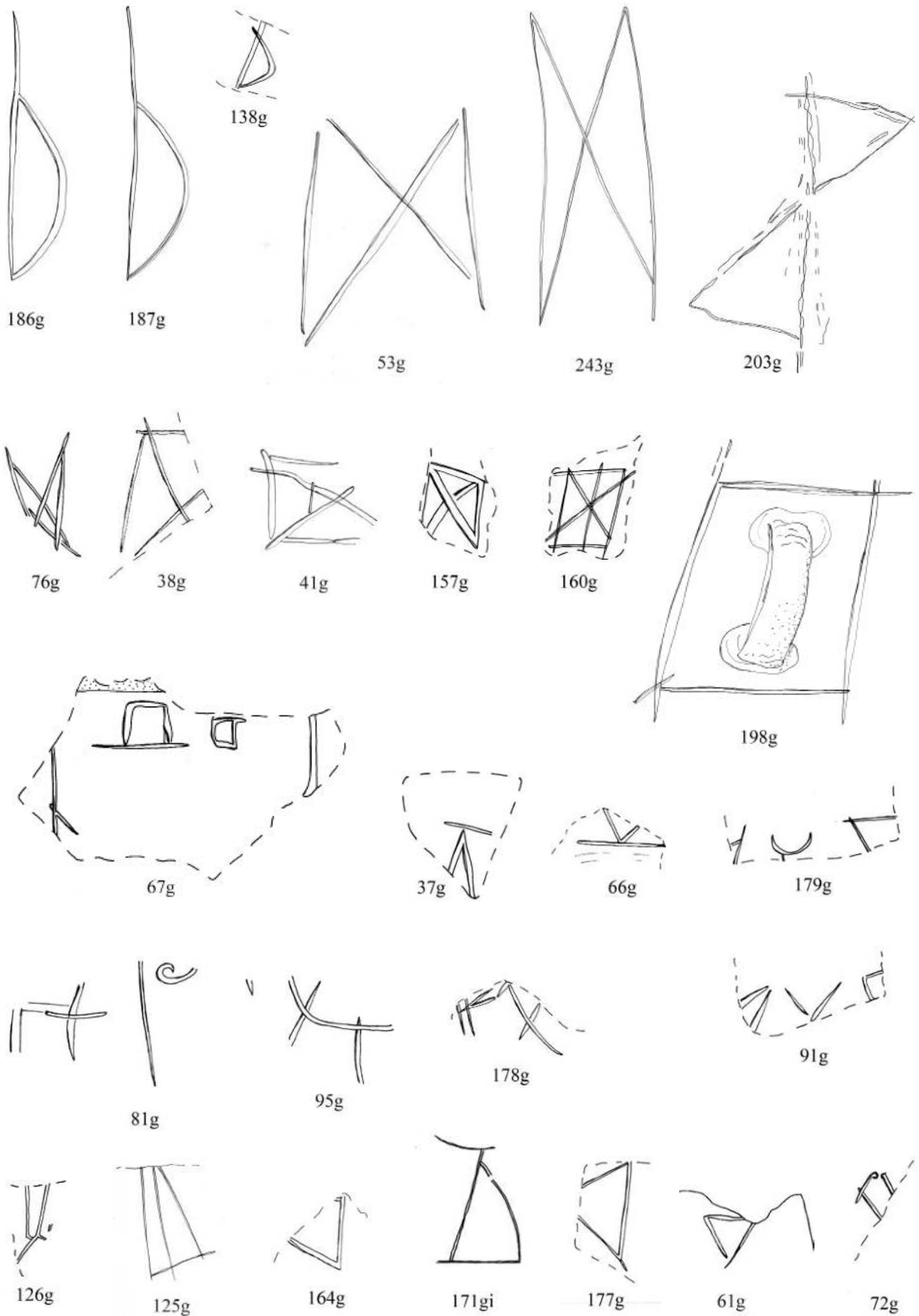

Figure 5.2. Symbols and/or 'Greek' (?) letters, continued (scale 1:2).

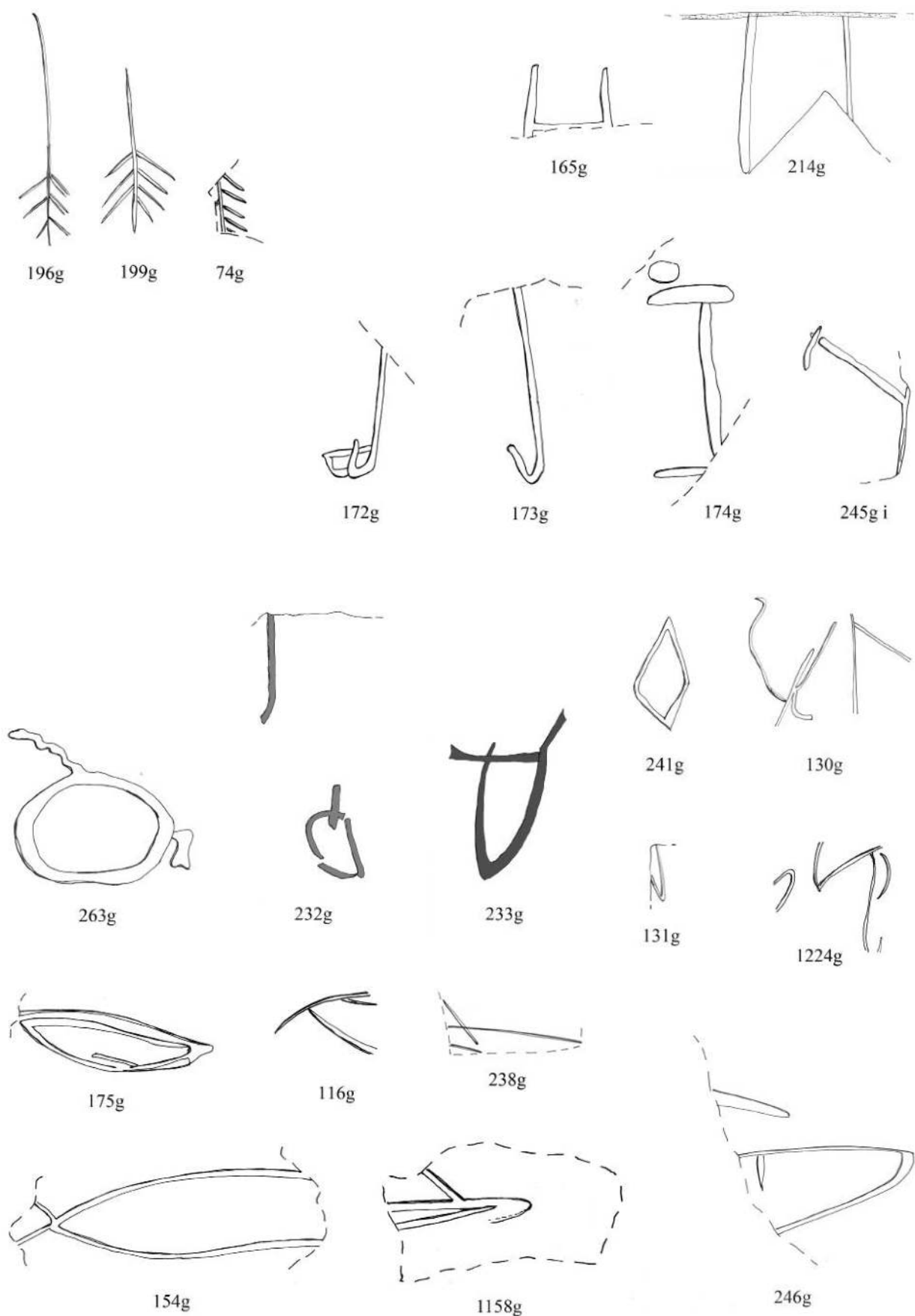

Figure 5.3. Symbols and/or 'Greek' (?) letters, continued (scale 1:2).

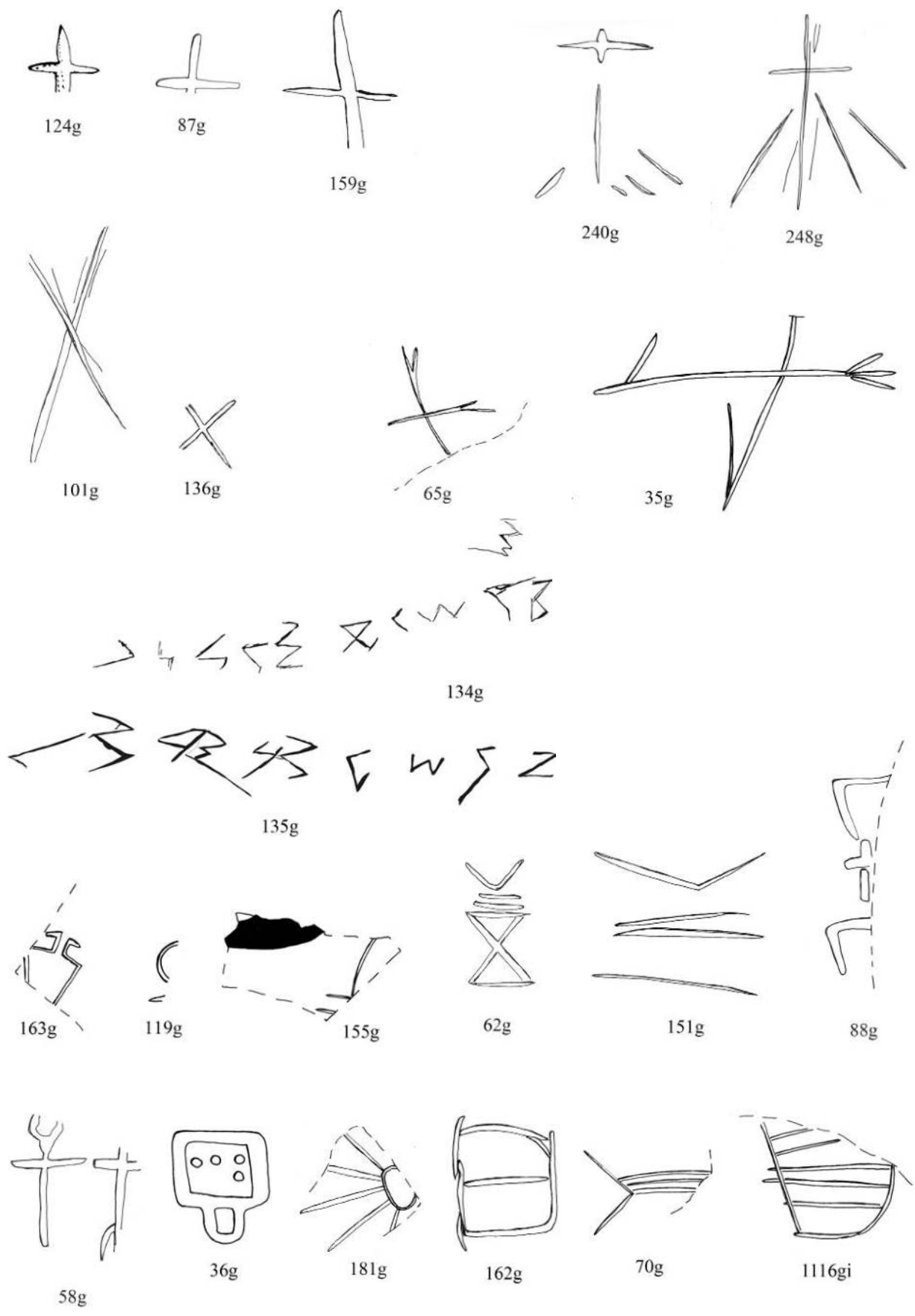

Figure 5.4. Napatian and Meroitic graffiti, symbols/ letters (scale 1:2).

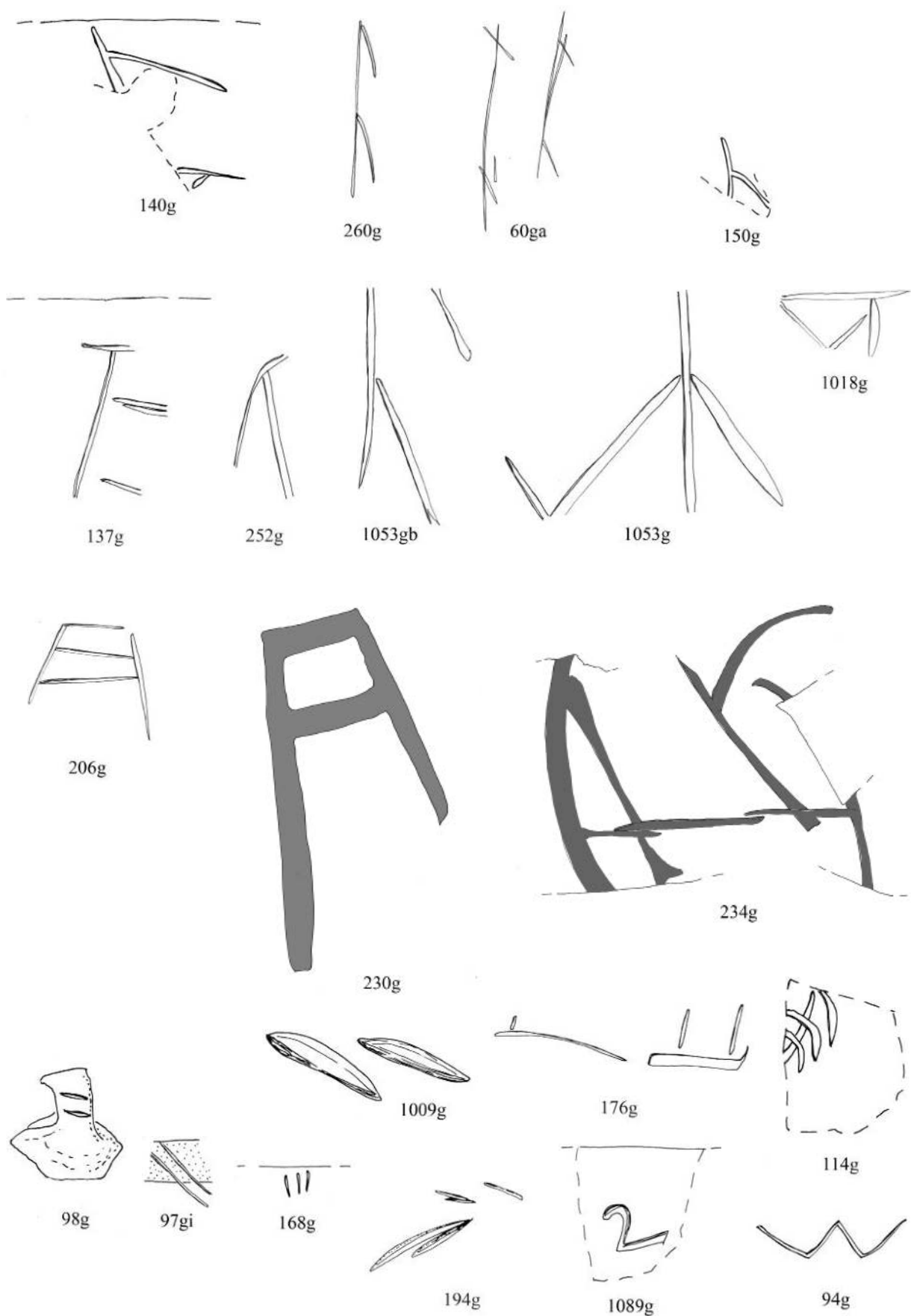

Figure 5.5. More incised symbols; tituli picti (230g and 234g); potter's marks, made pre- and post-firing (scale 1:2).

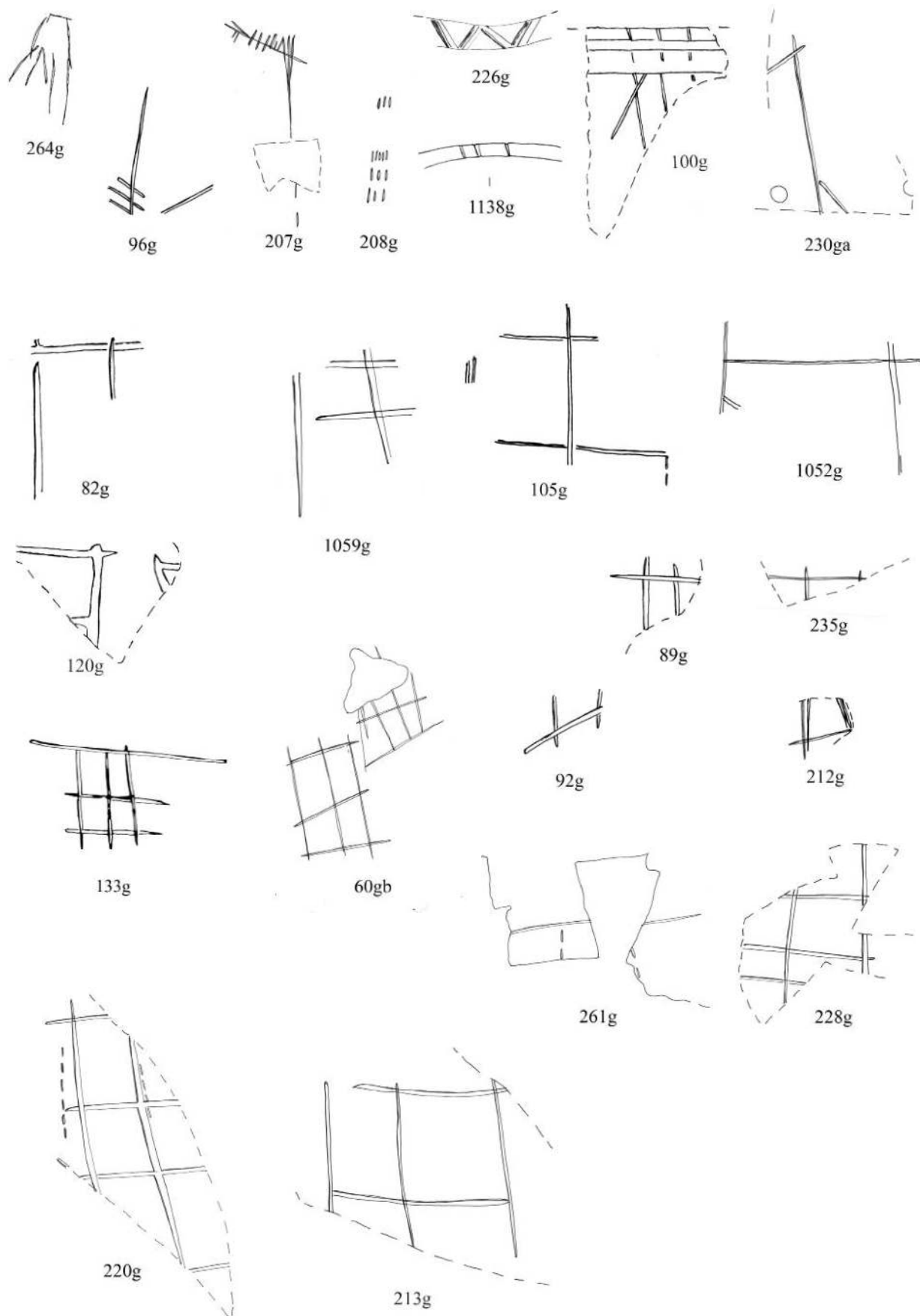

Figure 5.6. Graffiti chiefly found on Napatan amphorae, in particular the grid motif (scale 1:2).

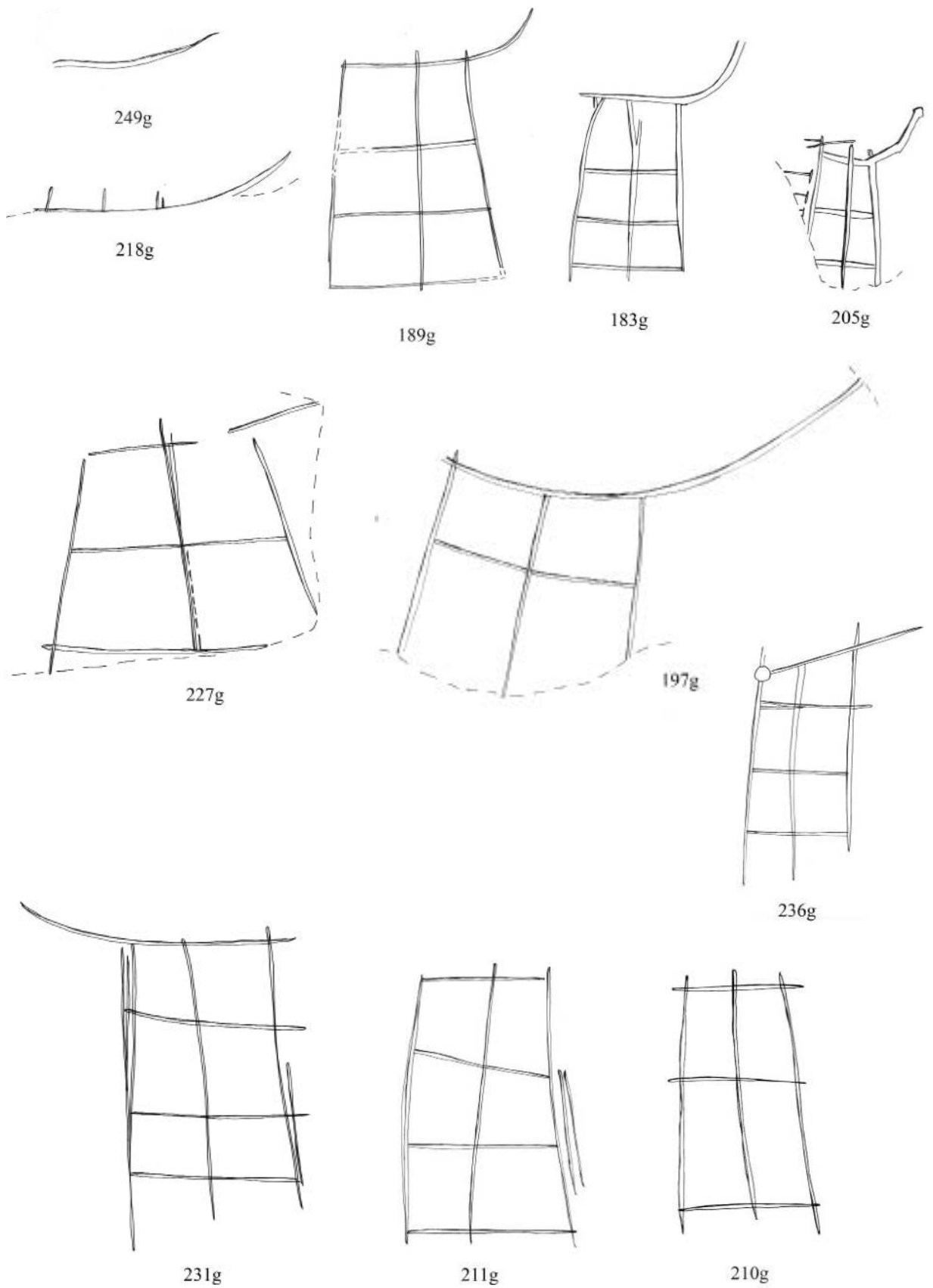

Figure 5.7. Further variations of the grid motif on Napatan amphorae (scale 1:2).

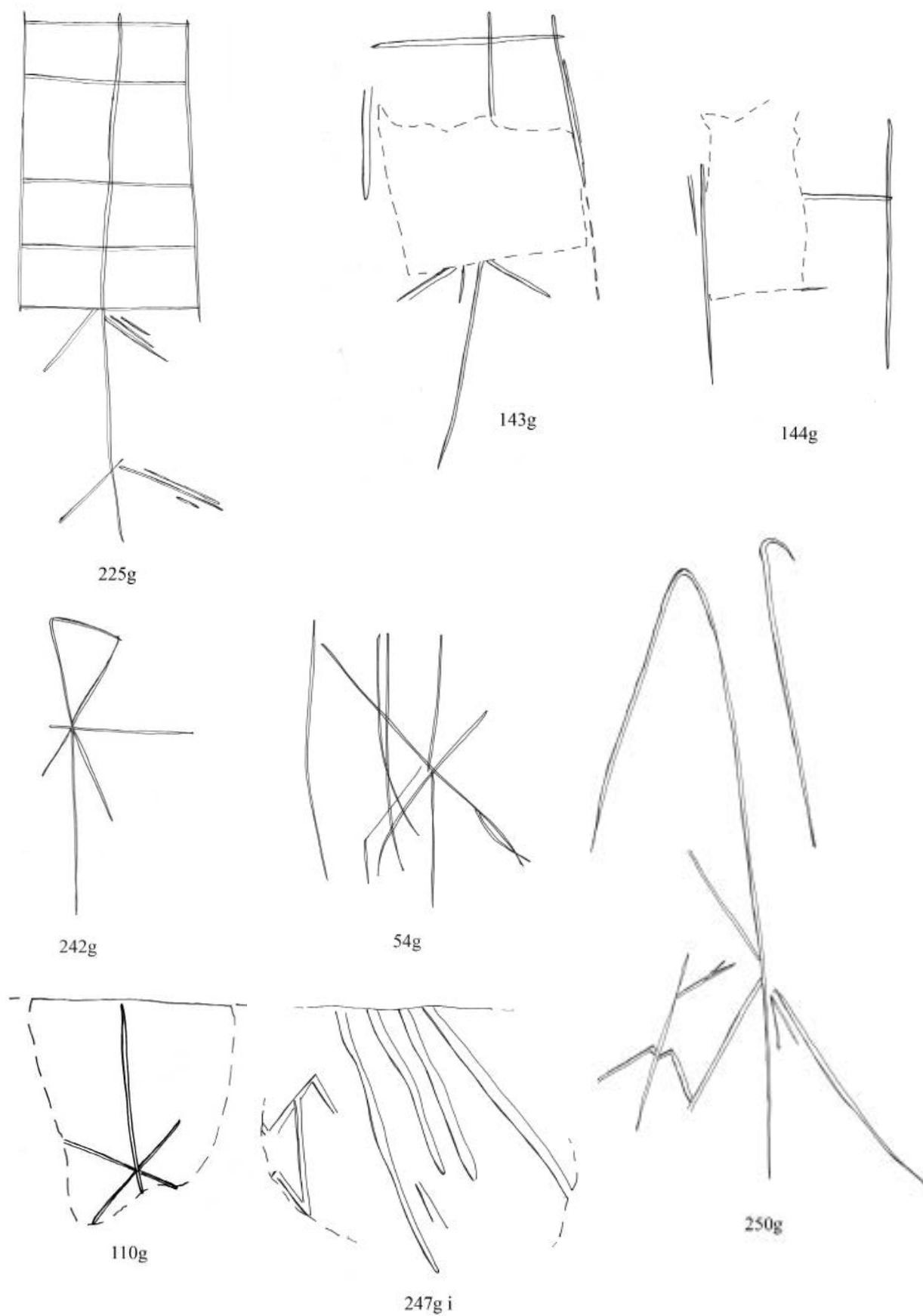

Figure 5.8. Grid motifs and variations thereof (scale 1:2).

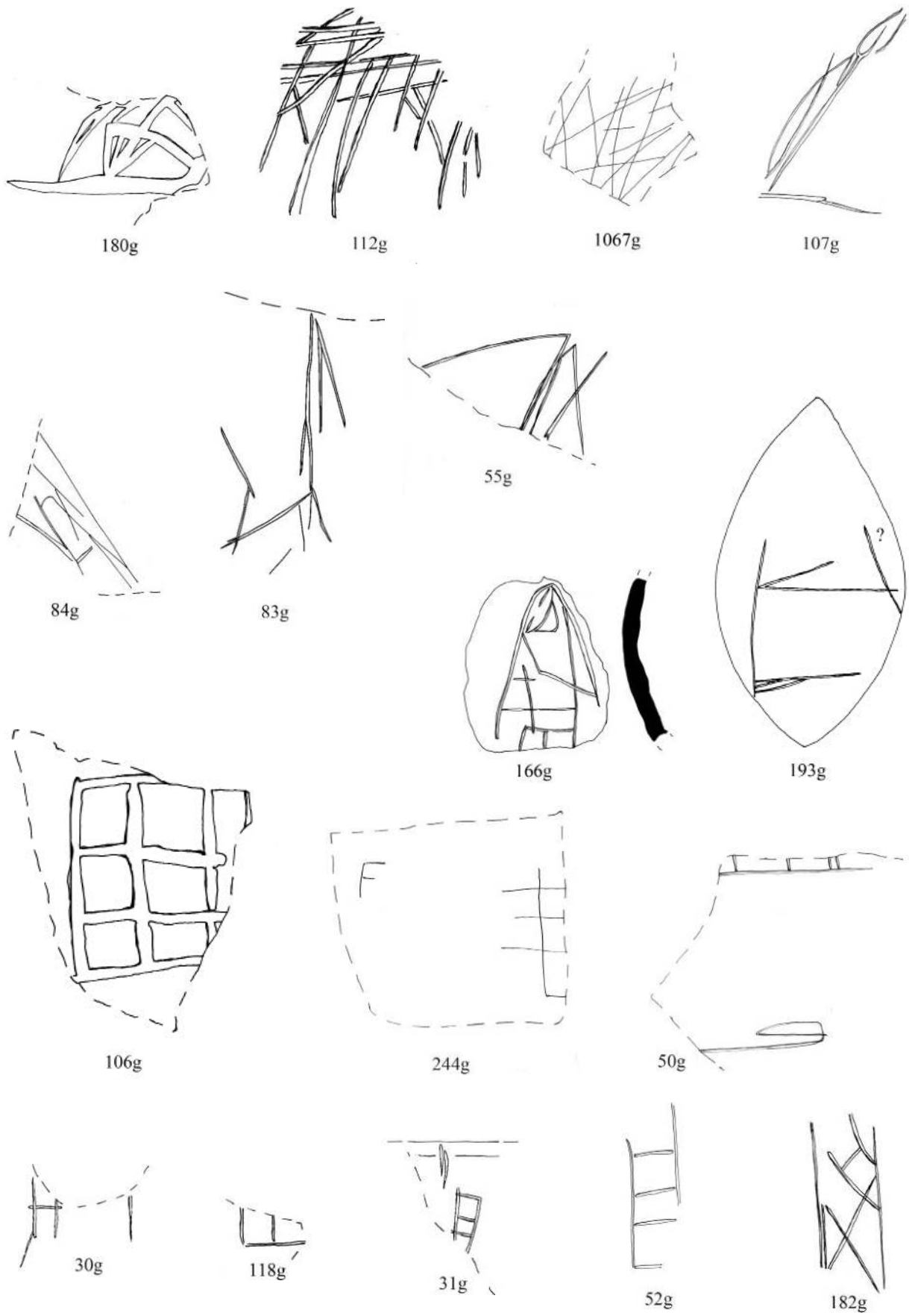

Figure 5.9. Random scribbles (?) and rectangular motifs (scale 1:2).

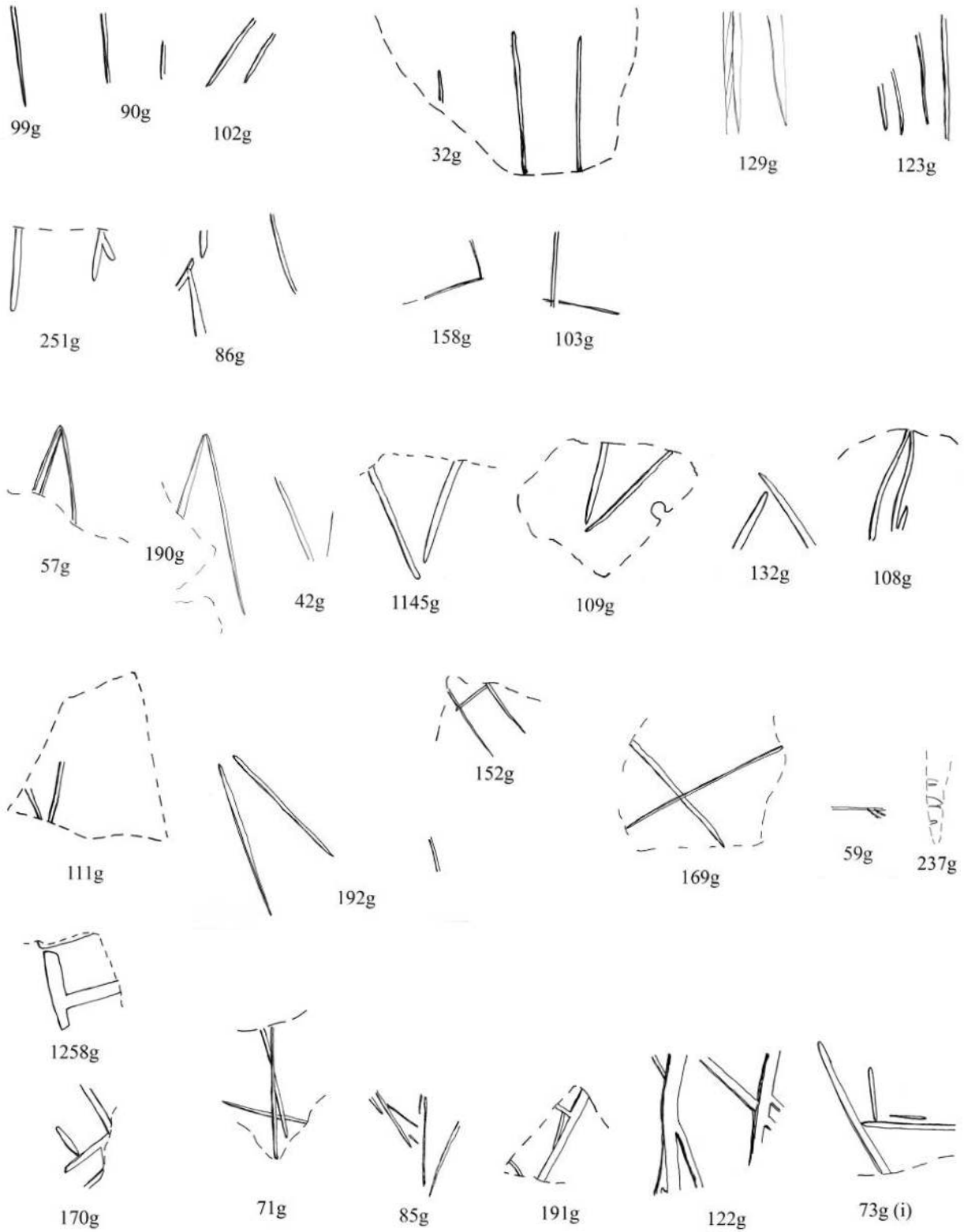

Figure 5.10. Particularly fragmentary marks (scale 1:2).

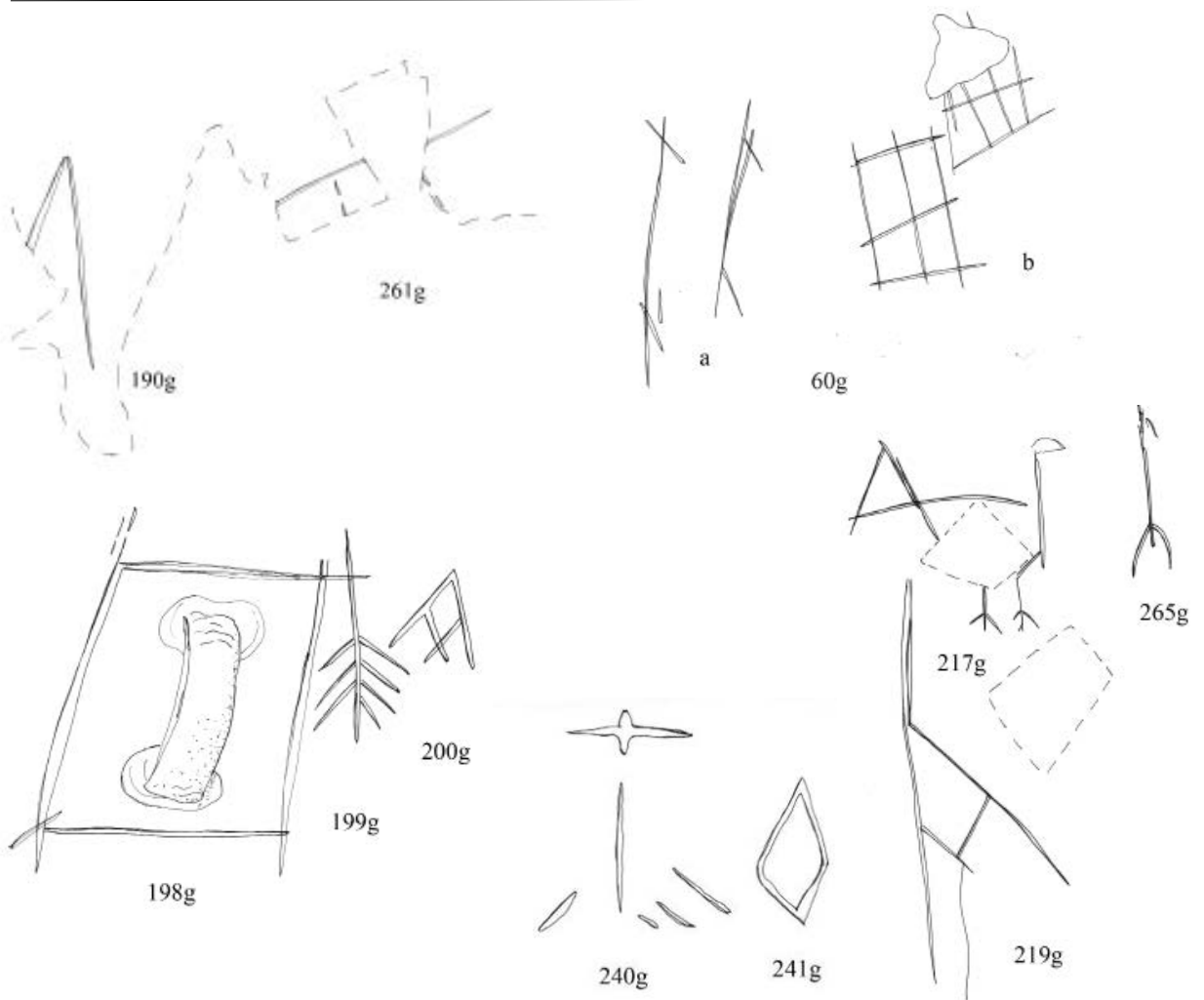
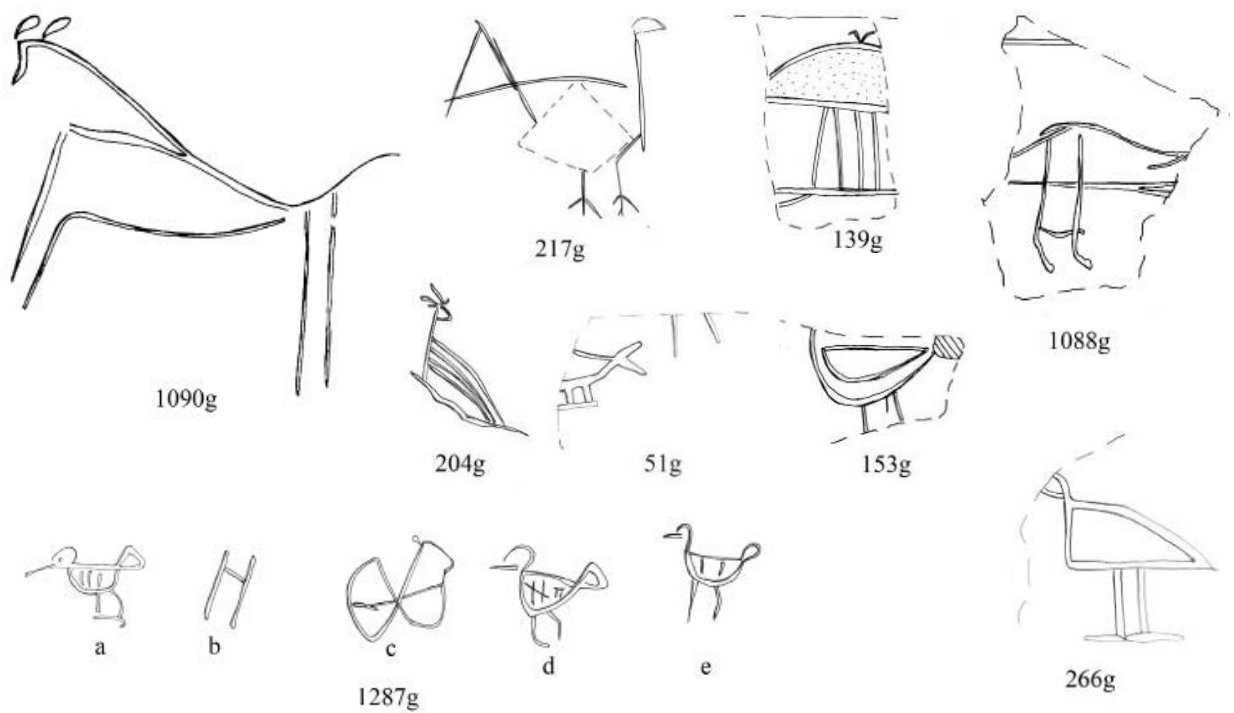

Figure 5.11. Various birds and a horse (?); composite graffiti scenes (scale 1:2).

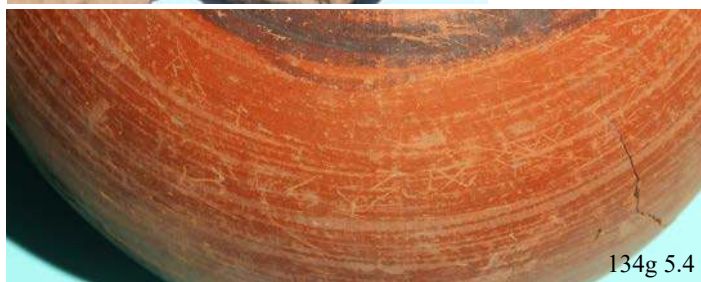
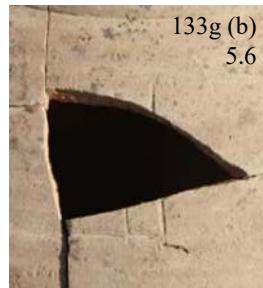
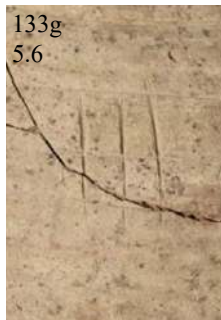

Plate 5.2. Selected photos of the graffiti, including 216g (not drawn).

TABLE 5. GRAFFITI AND POT MARKS.

Fig.	Graf.	Provenance	Type	Form	Fab.	Dec.	SH	Man.	Comments
5.1	33	B		-	-		BS	-	
5.1	34	98/1/4.47	2114	jar	-		R	WM	
5.1	56	(BE1)41		BO	71	820IW	BS	HM	
5.1	+75	(AD5)41,61	3221	amph	98		PRO	WM	Plate 5.2 pre-firing hole nr B
5.1	80	(AD5)28		jar /dish	92		BS	WM	
5.1	93	(AD5)198	3492	bowl	94	851 15MM	R	WM	
5.1	+104	(AD5)276	3817	bowl	110	825EI GR/CR	R	HM	Plate 5.2 pre-firing
5.1	113	(FQ4)2		amph	102	825EW ribbed	BS	WM	
5.1	115	(FQ4)7		amph	102	825EW ribbed	BS	WM	
5.1	117	(FQ4)88	2570	bowl	92	RBRIE V short	R	HM	
5.1	128	(FO6)91	3831	bowl	110	RBRIE	R	HM	
5.1	141	(FP6)57	4196	basin	110	910E RBR TOP	PRO	HM	paint dribble?
5.1	142	(FP6)	4196	basin	110L	910E RBR TOP	R	HM	
5.1	156	(CF4)17		jar	94	825ER	BS	HM	pre-firing
5.1	161	(JG2)180 gr. 150		amph	113	OF ribbed	SH/BS	WM	
5.1	167	(CF4)139		bowl	110		BS	HM	fragment
5.1	171	(CE4)85		jar	94F	820ER	BS	WM	on interior
5.1	188	(FO7)52		amph	128	ribbed	BS	WM	
5.1	+219	(FO7)85	4685	amph	102	GR ribbed	PRO	WM	Plate 5.2
5.1	+265	(FO7)85	4685	amph	102	GR ribbed	PRO	WM	Plate 5.2
5.1	1152	(AD5)260	2025	bowl	92	RBR	R	WM	ptd
5.2	37	(BE3)130	2626	dish	69		R	WM	
5.2	38	(BE3)37	2347	jar	2		R	HM	
5.2	41	(BE2)37		jar	67		BS	WM	
5.2	53	533 23	2247a	dish	1	crude 910	R	HM	
5.2	61	(AB5)223	2878	jar	94	820ER (800E)	B	WM	
5.2	66	(AB4)20		jar	92		BS	WM	
5.2	67	(AB4)23		bowl	65	820EW RBRE	BS	WM	
5.2	72	(FS3)2	2699	bowl	92		R	WM	
5.2	76	(AC5)38	3255	beaker	69	H820ER	R	WM	
5.2	81	(AD5)149		amph	102	ribbed	BS	WM	
5.2	91	(AD5)214		amph	113		SH	WM	Napatan
5.2	95	(AD5)198		amph	65	ribbed	BS	WM	
5.2	125	(TG5)73		jar	67		BS	WM	
5.2	126	(TG5)73		jar	92	825ER	BS	WM	
5.2	138	(FO6)148		bowl	110		BS	HM	
5.2	157	(CF4)20		bowl	69		BS	HM	pre-firing
5.2	160	(TG5)1		jar	110		BS	HM	
5.2	177	(CF3)2		jar	132	820EO	BS	WM	
5.2	178	(CF3)2		jar	132	820EO	BS	WM	
5.2	179	(CF4)99	4559	bowl	110		R	HM	
5.2	186	(FO7)20	4665	amph	102		RH	WM	with 183g 187g
5.2	187	(FO7)20	4665	amph	102		RH	WM	with 183g 186g
5.2	+198								
5.3	+199	(FO7)20A	4662	amph	103	825EW ribbed	PRO	WM	Plate 5.2
5.1	+200								
5.2	202 203	(FO7)85	4658	amph	128	ribbed	PRO	WM	no drawing of 202g
5.2	243	(AD5)28	3238	bowl	92	rough & irregular	R	HM	salt encrusted
5.3	74	(FR3)1		amph	32	ribbed	BS	WM	
5.3	1158	(FQ4)2		jar	67		SH	HM	pre-firing
5.3	116	(FQ3)41		jar	132	820EW ABR	BS	WM	
5.3	130	(TG5)88	-	-	-	-	BS	-	
5.3	131	(TG5)113		jar	130		BS	WM	
5.3	154	(CF4)1		jar	110		BS	HM	
5.3	165	(CE4)17	4394	BJ	94L	820ECR +/-RI	R	WM	
5.3	172	(CE4)52		bowl	110		BS	HM	
5.3	173	(CE4)48		jar	110		BS	HM	pre-firing

Fig.	Graf.	Provenance	Type	Form	Fab.	Dec.	SH	Man.	Comments
5.3	174	(CF4)141		basin	94		BS	HM	
5.3	175	(CF3)41		jar	92C		BS	HM	
5.3	196	(FO7)90	4659	amph	113		BH	WM	
5.3	214	(FP6)151,154	2025c	bowl	100		R	HM	999
5.3	232	(FO6)99		amph	102	very oil stained	BSB	WM	<i>titulo picto?</i>
5.3	233	F1		amph	102		H BS	WM	<i>titulo picto</i>
5.3	238	(JD2)43		BJ	132	820EO	SH	WM	
5.3	+241	(GD3)83a gr. 38	4799	amph	130	ribbed	PRO	WM	Plate 5.1 999 240g
5.3	246	(BE3)49	2256	stor jar	94	820IR	R	HM	
5.3	262	(CF4)113	4482	bowl	92		R	HM	
5.3	263	(BF2)11?		jar?	67?	820ER 1003y x 2	BS	HM	
5.3	1224	(CF3)13		cup	92		BS	HM	pre-firing
5.4	36	(BE4)14,19	2238	stge jar	92	1012	R	HM	898
5.4	58	(AB5)59		jar	67		BS	WM	<i>ankhs</i>
5.4	+62	1075 12	2882	BJ	130	820EO 831EBL	PRO	WM	Plate 5.2
5.4	70	(HA2)1	2025	bowl	69	822R int abr	R	HM	
5.4	87	(FS3)11	3438a	basin	110	822BR RBR TOP	R	WM	
5.4	88	(JE3)24		BJ	106	820EO	BS	WM	Meroitic jar
5.4	119	(TG5)73	3984	bowl	-	820ER	R	-	
5.4	124	(TG5)73	4065	bowl	94	820EP	R	WM	
5.4	+134	(JH3)130 gr. 116	4326	BJ	132	1292	PRO	WM	Plate 5.2 Mer inscr
5.4	+135	(JH3)130 gr. 116	4330	BJ	100		PRO	WM	Plate 5.2 Mer inscr
5.4	151	(CF4)1	2175	dish	110	910E	R	HM	
5.4	155	(CF3)1		jar	115	820EO 831EBR	BS	WM	
5.4	159	(TG5)1	4431	amph	93		R	WM	
5.4	162	(CE4)42	4456	CP	92		R	HM	or SW, pre-firing
5.4	163	(CE4)14	4459	jar	130	163g 820EO 850 x 1	SH	WM	Meroitic hieroglyph post-firing
5.4	164	(CF4)17		jar	115	820ER exfoliating	BS/SH	WM	
5.4	181	(TG5)12		jar	92		BS	HM	
5.4	+240	(GD3)83a gr. 38	4799	amph	130	ribbed	PRO	WM	Plate 5.2 999 241g
5.4	248	(FO7)20,39	4660	amph	102	825EW ribbed	PRO	WM	
5.4	1116	(HA2)91	3149	bowl	92		PRO	HM	incised, interior
5.5	35	(BE3)18		brick	71			HM	poorly fired
5.5	+60a	(AC6)22,27	2826	amph	65	825EW ribbed	RH	WM	Plate 5.2
5.5	65	(AB4)20	2916	jar	65		R	WM	
5.5	94	(AD5)198		jar	94	820IW blackened	BS	WM	pre-firing
5.5	97	(AD5)236	2656	bowl	110	RBRI	R	HM	
5.5	98	(AC5)78	2028	amph	102		H	WM	post-firing
5.5	101	(AD5)273	3792	stor jar	125	820ER 825ICR	B	WM	
5.5	114	(FO4)59		jar	92	sooty ext	BS	HM	pre-firing
5.5	136	(FO6)89		amph	102	ribbed	BS	WM	
5.5	137	(FO6)116	3856	bowl	110	CRR	R	HM	
5.5	140	(FP6)34	3852	bowl	110	825EICR 910E	R	HM	
5.5	150	(CE4)1	4330	BJ	92F	820EBR	R	WM	
5.5	168	(CE4)47	4510	bowl	110	black surfaces	R	HM	pre-firing
5.5	176	(CF4)161	4566	bowl	94	822W burnt	R	WM	post-firing
5.5	194	(FP6)188	4661	pot stand	94	IB base?	PRO	WM	pre-firing
5.5	206	(FO7)17	4672	amph	113	825EW ribbed	R	WM	
5.5	230	(FO/P7)39 (FO7)65,67,69, 76,78,85,89,90 (FP7)19,65, 69,89,95,102	4753	amph	128		SH	WM	<i>titulo picto</i>
5.5	234	(FP7)5,17,103,106, 105,122	4191	amph	113	825ECR	SH	WM	<i>titulo picto?</i> part oil stained
5.5	245i	(BD2)3	2256	stor jar	94	1063	R	WM	
5.5	252	(FZ1)10,25	4833	bowl	110	804E 810I	R	HM	999
5.5	260	(FO7)22a	4669	amph	102	ribbed	R	WM	
5.5	1009	(BE3)17 (JG2)1	2338	bowl <i>dolia</i>	80 90		R BS	HM	pre-firing and post-firing gouges
5.5	1018	(BE3)136		jar	67		BS	HM	graffito??

Fig.	Graf.	Provenance	Type	Form	Fab.	Dec.	SH	Man.	Comments
5.5	1053	(AB4)11		jar	97		BS	WM	
5.5	1053b	(AB5)23,24		amph	67	850 x 1	BS	WM	pre-firing 999
5.5	1089	Z		BJ /jar	-		R	HM	potter's mark, Meroitic hieroglyph
5.6	+60b	(AC6)22,27	2826	amph	65	825EW ribbed	RH	WM	Plate 5.2
5.6	82	(AD5)154		amph	93	825EW ribbed	BS	WM	
5.6	89	(FR3)00	3464	bowl	9	825EIW	R	HM	
5.6	92	(AD5)219		amph	23	825EW ribbed	BS	WM	
5.6	96	(AD5)230	3238	bowl	110	CRR	R	HM	
5.6	100	(AC5)77	3784	amph	113	825EBL? ribbed	R	WM	r notches
5.6	105	(AD5)276		amph	102	825EW ribbed	BS	WM	
5.6	120	(TG5)73	3992	amph	93	ribbed	R	WM	
5.6	+133	(FO6)145	4337	amph	128		PRO	WM	+133gb Plate 5.2
5.6	197	(FO7)65,86	4671	amph	102	ribbed R notches	R	WM	999
5.6	207 208	(FO7)69,85	4680	amph	128	825EW ribbed	RH	WM	
5.6	212	(FO6)180		bowl	110		BS	HM	
5.6	213	(FO7)91 (FP7)19	2826	amph	102	825EW 850 ribbed	R SH	WM	
5.6	220	(FO7)2		amph	102	825EW ribbed	BS	WM	
5.6	226	(FO7)90	4674	amph	103	825EW ribbed	R	WM	oblique r notches
5.6	228	F1		amph	-		BS	WM	
5.6	230a	(FP7)19		amph	113	820EGR 850 x 2	BS	WM	
5.6	235	(FO7)34		amph	102	825ECR	BS	WM	
5.6	261	(FP7)2,17,23,29	4698	amph	113	825EW 825IP ribbed	R	WM	999 190g
5.6	264	(FO7)65	4676	amph	113	825EW ribbed	PRO	WM	random scratch?
5.6	1052	(AB5)43 (AC6)30		amph	23 67	ribbed	BS	WM	2 similar examples
5.6	1059	(AB4)7	2028	amph	93	ribbed	H	WM	
5.6	1138	(AD5)183	3425		110	825IW 910	R	HM	post-firing r notches on bowl
5.7	183	(FO7)20	4665	amph	102	825EW ribbed	RH	WM	
5.7	189	(FO7)39	4663	amph	113	825EGR ribbed	PRO	WM	
5.7	+205	(FO7)78	4670	amph	103	825EW ribbed	R	WM	Plate 5.2
5.7	210	(FO7)2,20	4681	amph	113	ribbed worn 850 x 8	RH	WM	r notches
5.7	211	(FO7)1,20,30	4679	amph	-	mult 850	R	WM	
5.7	+216	(FP7)112	4708	dish	92	RBRI	PRO	HM	Plate 5.2 no dr, interior
5.7	218	(FO7)2	4740	amph	102	GR surf ribbed 850 x 4	R	WM	
5.7	227	F1		amph	-			WM	
5.7	231	(FO6)134 (FO7)90	4755	amph	18	R notches ribbed		WM	
5.7	236	(FO7)54	4629	amph	103 113		RH	WM	
5.7	249	(FO7)2	4742	amph	128	825ER ribbed	R	WM	
5.8	54	561 2		BJ	29	TR 820EO	BS	WM	graffito or scratch?
5.8	106	(AD5)289		jar	110	very lumpy int	BS	HM	
5.8	110	(AC5)145	2022a	CP	110		R	HM	
5.8	143 144	(FP6)9 (FP7)2,3,5,17	4678	amph	98	ribbed	PRO	WM	
5.8	166	(CF4)139		bowl	92	810E	BS	HM	post-firing
5.8	193	(FP7)53		bowl	110	rough surface	BS	HM	
5.8	225	(FO7)76	4667	amph	102	825EW ribbed	R	WM	
5.8	242	(AD5)97	3258	dish	92	patchy 825IR	PRO	WM	
5.8	247i	(AC5)131	3828	<i>doka</i>	92		PRO	HM	
5.8	250	(FP7)19 (FO7)2,19,20	4816	amph	103	825EW ribbed	PRO	WM	
5.9	30	(BF2)1	2015	beaker	67	800E	B	WM	
5.9	31	(BE2)1	2030	bowl	6	1001y 810E	R	HM	see Plate 4.2
5.9	50	(AB5)20		amph	67		BS	WM	
5.9	52	(AB4)10		amph	67		BS	WM	
5.9	55	(BE1)1	2175	dish	1		R	HM	
5.9	83	(HA2)227		stge jar	67		BS	WM	

Fig.	Graf.	Provenance	Type	Form	Fab.	Dec.	SH	Man.	Comments
5.9	84	(AD5)168		jar	67F	825IR	BS	WM	rd b
5.9	107	(AC5)126		jar	92	lumpy I	BS	HM	
5.9	112	(FR4)7		<i>doka</i>	110	910	BS	HM	palm leaf impr.
5.9	118	(FQ3)43		jar	80		BS	WM	
5.9	180	(CF3)49		jar	94	825ER	BS	WM	
5.9	182	(FO6)172	-	-	-	-	-	-	
5.9	244	(FP6)24	3862	bowl	92	825EICR R805EI RBRIE	R	HM	charcoal
5.9	1067	(AC6)22	2116	jar	11	820ER	R	HM	random scratches?
5.10	32	(BF2)1,11 (AB4)23	2042	amph jar	65 67 93		BS	WM	4 instances
5.10	42	(AB6)7		amph	93		BS	WM	
5.10	57	(BF2)51	2175	dish	45		R	HM	
5.10	59	(AC6)22	2826	amph	82		R	WM	
5.10	71	(FS3)2		bin	92		BS	HM	
5.10	73	(FS3)2	2699	bowl	92		R	HM	incised, interior
5.10	85	(AC5)76	3413	amph	23	825EW ribbed	BS	WM	
5.10	86	(AD5)197		amph	67	ribbed	BS	WM	
5.10	90	(FR3)00		amph	65	ribbed	BS	WM	micaceous surface
5.10	99	(AD5)207 (TG5)46		amph	92F 92	ribbed	BS	WM	1 vertical line
5.10	102	(AC5)93		amph	98	OF ribbed	BS	WM	
5.10	103	(AC5)111		amph	98	825EW ribbed	BS	WM	
5.10	108	(AD5)256		jar	110		BS	HM	
5.10	109	(AD5)296		CP	110		BS	HM	pre-firing hole 1cm
5.10	111	(AC5)145 (TG5)85		amph bowl	102 110	825EW ribbed	BS	WM HM	2 instances
5.10	122	(TG5)91		jar	67	820ER	BS	WM	
5.10	123	(TG5)91		jar	94	820ER	BS	WM	
5.10	129	(TG5)89	-	-	-	-	BS	-	incised
5.10	132	(TG5)65		jar	94		BS	WM	
5.10	152	(CF4)1		bowl	67	822R	BS	HM	
5.10	158	(CF3)11	4414	dish	110	910E RBR?	R	HM	
5.10	169	(CE4)71 (CF3)49 (TG5)4		CP	110		BS	HM	2 crossed lines, 3 instances
5.10	170	(CF3)80		jar	92		BS	WM	post-firing
5.10	191	(FP6)92		amph	98	825EGR ribbed	BS	WM	
5.10	192	(FO7)25	2656	bowl	110	RBRI thin	R	HM	pre-firing
5.10	237	(JD2)51		jar	132	820EO mottled	BS	WM	
5.10	251	(JC3)16		jar	106		BS	HM	coarse
5.10	1145	(AD5)217		jar	110		BS	HM	incised
5.10	1258	(FP6)188		jar	92		BS	HM	incised
5.11	51	(AB5)32		jar	66	825EW	BS	WM	
5.11	60	(AC6)22,27	2826	amph	65	825EW ribbed	RH	WM	
5.11	139	(FO6)150	3862	bowl	110	RBRIE	R	HM	
5.11	153	(CF4)1		jar	111	820ER	BS	WM	
5.11	190	(FP7)2,17,23,39	4698	amph	113	825EW 825IP ribbed	R	WM	999 261g
5.11	204	(FO7)69	4666	amph	103	825EW ribbed	RH	WM	
5.11	+217	(FO7)85	4685	amph	102	GR ribbed	PRO	WM	Plate 5.2
5.11	266	Area T		BC	25		PRO	HM	
5.11	1088	Z		jar	-	-	BS	WM	
5.11	1090	(ZH5)30	3040	jar	92	-	R	HM	pre-firing
5.11	1287	(FQ3)31	4834	bowl	92	-	PRO	HM	incised on unfired bowl

6. The Napatan amphorae from Building F1

Within the rooms of Building F1 an unusually large¹ number of complete or nearly complete Napatan amphorae was found (see Table 6.1, Figures 6.2 & 6.3); beyond these further sherds belonging to similar forms, but impossible to reconstruct, are listed in Table 6.2. With the exception of 4337x, which was found almost intact except for its missing base, all were broken, whether in antiquity or crushed over time by the accruing overburden. The building must have at some point undergone a considerable amount of disturbance, as sherds from some vessels were found within the same room (but not the same layer), but about half of the amphorae were found with their sherds scattered across adjoining rooms (see Table 6.1 & Figure 6.1). This is particularly well illustrated by the instance of part of the mid-section of 4191x with a possible *titulo picto*, which was made up of sherds from no less than seven contexts, in Room IA and the street.² The amphorae are particularly concentrated in Rooms III and IV, but occur in all rooms except X and XI, with very few sherds present in V, VIII and XII. A considerable amount of time was devoted to the reconstruction of these amphorae. They come in three basic sizes: rim diameter of 7.5-8cm, 10cm and 14cm. Height varies between 46cm and 51cm for those with the narrower rim openings to just over 55cm for the larger size. The handles are small and are located some 10cm below the shoulder; while they are not always precisely placed, the intention was clearly for them to be at 180° to each other. Occasionally the exterior of the base has been fired (or painted?) with an oxidised area around the centre of the base. Whether this was an intentional ‘decorative’ feature or simply accidental is unclear (Plate 6.1).

¹ Compared to the number of such vessels found in the Royal Treasury at Sanam (Vincentelli 2018b, 178-79), the quantities in Building F1 are, of course, far more modest.

² Evidently keeping track of what context the sherds belonging to a particular amphora came from was extremely time consuming, particularly in view of the number of vessels involved and the similarity of their forms (and of their fabrics). The conclusion we can draw from the result is that the site had at some point been considerably disturbed, but that the vessels must have broken within the building.

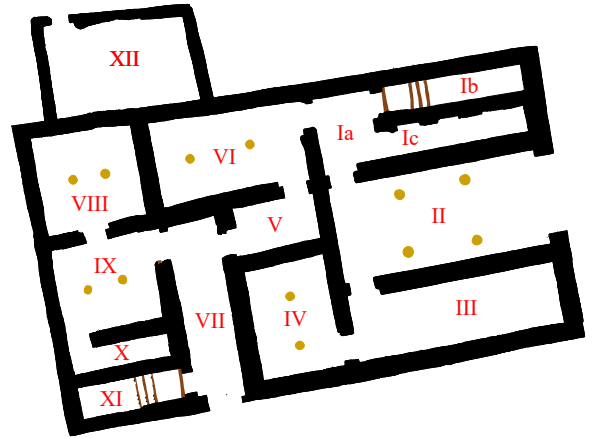

Figure 6.1. Building F1 – location of the rooms.

Since we have a number of almost complete amphorae, it is possible to extrapolate from the weights of these to estimate what percentage of an amphora random sherds found elsewhere may represent. The largest amphora recovered, 4337x, albeit with its base missing, weighs just over 8kg, while the smaller types, such as 4676x, weigh c. 2.8kg, although others, less complete, weigh a few hundred grams more. Other variants of this type, such as 3221x, 4799x and 4800x (3.1.4), although less delicate in appearance, also weigh about the same.

When in transit the amphorae would have been sealed with bungs of mud; see Welsby and Taylor forth. for descriptions and a discussion of these, many of which sealed vessels of this type and often bear the imprint of the rim (see also Ruffieux 2007, 232, fig. 4). For seal impressions on bungs possibly related to the Napatan amphorae see Vincentelli forth. In a few instances the rims bore notches, cut post firing as if to accommodate string – going under or through the mud seal, so as to allow it to be pulled off more easily (Plate 6.2). However, this system was not used consistently, and there appears to be no correlation between the form and fabric of the amphora with rim notches, i.e.



Plate 6.1. Red circular areas on the bases of amphorae 4662x (l) and 3284x (r).



Plate 6.2. Notches cut in the rim for string placed under the mud stopper.

there is nothing to suggest that they derived from the same centre of production. In fact, since they are made post-firing, it is more likely that the notches relate to a period of reuse of the containers.

Several, but not all, have near the base a hole, whose diameter varies between 9mm and 20mm. In one case (4668x) it was possible to see that the hole had been made before firing. Most of these holes show some wear around the edges, and thus it is possible that more than one was made before firing (as the original edges would have been worn away, obliterating the evidence for at what point the hole was made). Certainly the holes were drilled with care, and are not part of some form of ritual ‘killing’ of the vessel. These perforations were remarked on by Griffith almost a century ago (Griffith 1923, 96), although no explanation has been put forward as to their function. Some amphorae do not have a hole at all, whereas on others the hole is still quite small and apparently made after firing, demonstrating that it was not standard, but was certainly a common feature. As a hole at the base would clearly have caused problems if it contained a liquid, particularly during transport; this suggests that the vessels contained dry goods, perhaps grain of some sort. Certainly the thinner-walled examples would have made poor containers for storing liquids over any length of time because of seepage. For those vessels

with the base hole made during manufacture, a seal must have been fixed to the hole during transport, in addition to that at the rim opening.

Why it was necessary to have this additional option for removing the contents is open to discussion. Removing the mud sealing often resulted in the breaking away of the rim, and it may have been in order to avoid this that the holes were drilled; something akin to tapping into a barrel? Another possible way in which the hole functioned is to allow the draining of a liquid – for example syrup from dates – but in this case it would only have been necessary for the hole to be drilled at the moment of reuse. ‘Base holes’ of this type have been found on Napatan amphorae at a great number of sites in Sudan (Qustul – Williams 1990; Third Cataract – Vila 1980; Fourth Cataract – Budka 2007; Sanam Abu Dom – Griffith 1923; Hillat el-Arab and Sanam – Vincentelli 2006; el-Kurru, Nuri, Barkal and Meroe – Dunham passim; Hamadab and surroundings – Wolf 2015, fig. 6, and personal observation in the Fourth Cataract). These examples are mostly found in funerary contexts, and indeed both amphorae 4799x and 4800x (3.1.4) from graves in R18 (GD3) also have them, but it is clear from the finds in Building F1 that it was a functional feature, not a ritual one. Holes near the base also occur in other storage containers, on forms 2719xb from Building B12, Room VI and 2792x, Building B14, Room III (cf. 3.4.11); they could date to the early 4th century BC. It is noteworthy that this practice disappears altogether in Meroitic period transport or storage containers. An example of the base hole occurs at Elephantine in a 4th century BC jar, on a form descended from the earlier Napatan period amphorae, with the hole made in the very centre of the base (Aston 1999, pl. 90.2396).

Graffiti on the amphorae from Building F1 are very frequent.³ A common type is a form of grid, and a distinctive variation on this type is a schematically incised camel, a flat line at the top curving slightly at one end to denote the head, two vertical lines indicating the legs and then one or more vertical lines in the middle and two or even three horizontal lines, forming a ‘table’ of sorts (see Figure 5.6 and especially 205g, Figure 5.7). As these symbols almost exclusively occur on this type of transport amphorae (89g and 262g occur on bowls, albeit the ‘grid’ in these case only appears to have one cross bar), it is tempting to suggest that information was entered in the boxes between the camel’s legs, perhaps with charcoal or even chalk, these additional more ephemeral marks having been worn away over time. Other symbols are also found (see Figure 5.1, *alpha*, *ypsilon* and *beta*...). Of these, the ‘ypsilon’ occurs also on other forms from various areas, bowls for example, both as post-firing graffiti and painted in red slip, and it is proposed here is that it is some form of good luck symbol, rather than denoting ownership by a family or clan, or an indication of the contents.

An intriguing feature of the pottery from Building F1 is that a number of sherds, particularly those found in Rooms

³ This is not to imply that graffiti on amphorae were not equally common elsewhere on the site, but it is only in Building F1 that we have such a concentration of complete or nearly complete amphorae.



Plate 6.3. Reconstructed oil stained amphora 4676x from Building F1.

Ia, III, IV, VI, IX and XII appear oil stained (or impregnated – they have turned a much darker colour and still attract dust and repel drafting tape), but as the same reconstructed vessel has sherds that are both stained and not (Plate 6.3), this does not relate to the contents of the vessels, and the staining must have occurred after breakage and the scattering of the sherds. Nor has a vessel that is complete or nearly complete been found that could have contained the oily substance that subsequently leaked over the broken pots. A number of the red-rimmed bowls appear to have been used as lamps after being broken (Plate 6.4) as they have soot-blackened rims at one point only and would have been able to retain plenty of fuel for use as a wick lamp. None of these reused pots bear any oil stains, so the fuel used in them (if indeed they were reused as lamps) was not the same as what soaked into the fill of the rooms, especially in Rooms IV and IX. At Kawa oil-stained pottery is only found in Building F1, with the single exception of a rim of form 2021x from (CE4)23 (the surface in Building C23, Room C).

The 427 ceramic counters that were also found in Building F1 (see Welsby 2023d, 139; Welsby and Taylor *forth.*, Appendix 4.A) were made (with only six exceptions) from sherds belonging to the RBRIE bowls/cups or coarseware cooking pots with surface treatment 910, in Fabric 110. Perhaps they were part of some form of accounting system of the distribution or sale of the contents of the Napatan amphorae, some of which show signs of wear and tear, i.e. they were reused several times (after?) arriving at Kawa.



Plate 6.4. RBRIE cups reused as lamps, principally found in Building F1.



That only six counters are made of amphora sherds indicates that these were still intact at the time the counters were in use, supporting the theory that their use was associated with the amphorae.⁴ The vast majority of the counters were found in Room II and a substantial number in the Street, with only a handful in Rooms III, VI, VII and XII.

Dating

The Napatan amphorae belong to the early Napatan period. While the amphorae found in Building F1 do not exactly conform to Aston's five groups of Marl clay storage jars (Aston 2007, fig. 5), several do match exactly, while slight variations in form clearly belong to the same type of vessel. The fact that we have examples of Aston's group II and V together would suggest that they are contemporary, although group V, is dated by Aston to the mid 6th and the end of the 5th century, while group II to the whole of the 7th century BC. The larger jars, 4337x, 4629x and 4753x, etc., also have the same characteristics (ribbing, position of handles, marl clay, relatively thin wall) as the smaller vessels, while the rilled rims are slightly chunkier, a necessity brought about by the larger size. Apart from three body sherds in Fabric 87C, no Levantine amphorae were found in the building, supporting the theory that they are only imported into Nubia in the Saite period or slightly later. The other vessel types found in Building F1 also fit well with the dating.

⁴ Interestingly, in Building F4, grid square (FZ1), out of a total of 13 such discs/counters, 10 were made from amphora fabrics.

Notes to Table 6.1, Figures 6.2 and 6.3 and Plates 6.5 and 6.6

Apart from form types 4115x, 4160x and 4629x, of which there are two examples each, the other types are represented by one vessel only.

In Table 6.1 the forms are listed in numerical order, but in here are two examples each, the other types are represented by one vessel only.

In Table 6.1 the forms are listed in numerical order, but in the figures according to form, hence the apparent randomness of the numbering, especially of the figures.

In the plates, which illustrate most of the forms shown in Figures 6.2 and 6.3, only the most complete or otherwise interesting forms are shown. In three instances there is no drawing but only a photograph of the form (4657x, 4658x and 4668x). Note also that in a few instances the restoration of the amphora progressed after the photograph was taken (4650x and 4672x for example).

Table 6.2 lists the types of amphora rim that were only recovered as fragments. They belong to types that have been found elsewhere at Kawa.

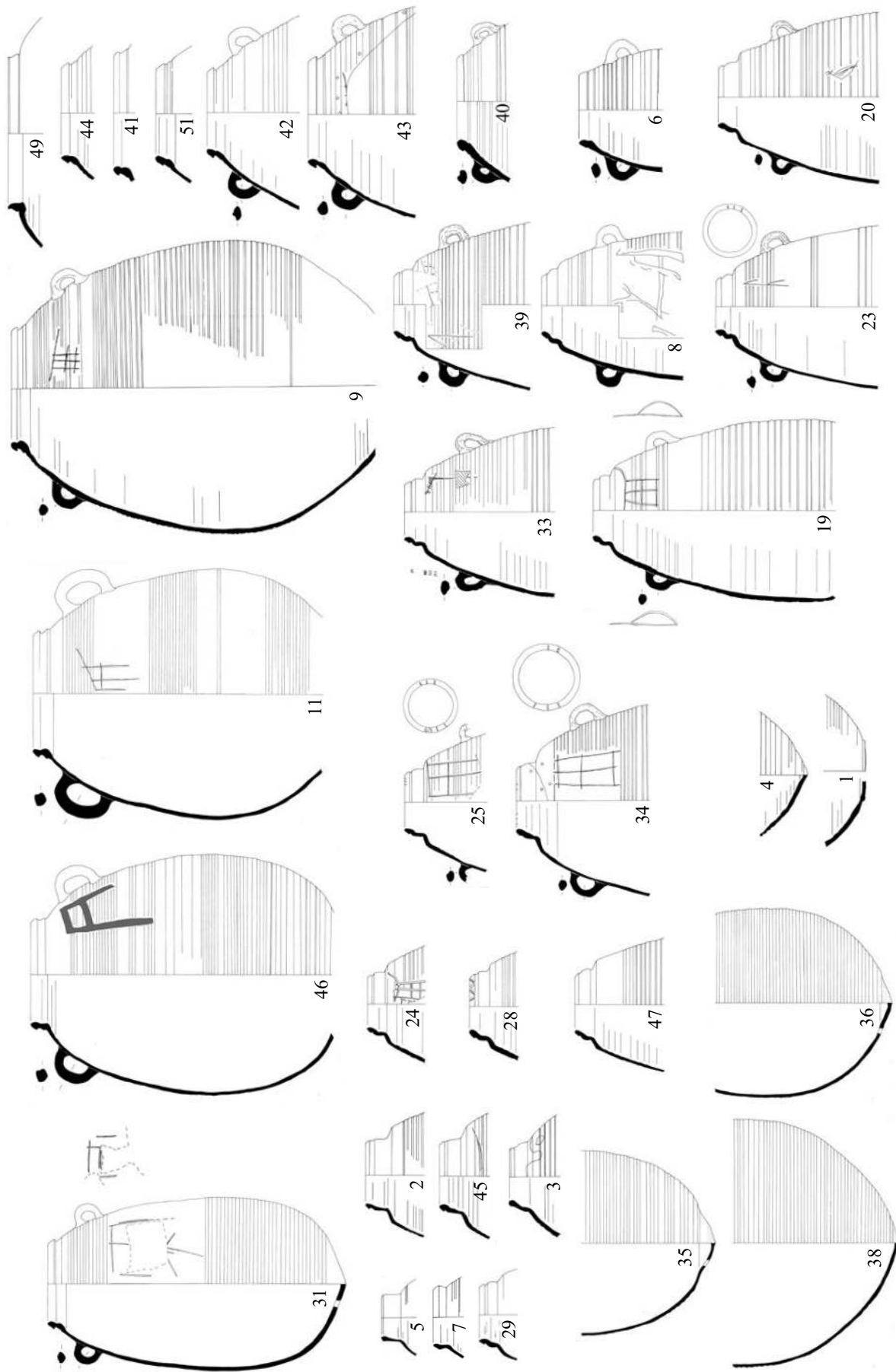

Figure 6.2. Amphorae forms from Building F1 (scale 1:8).

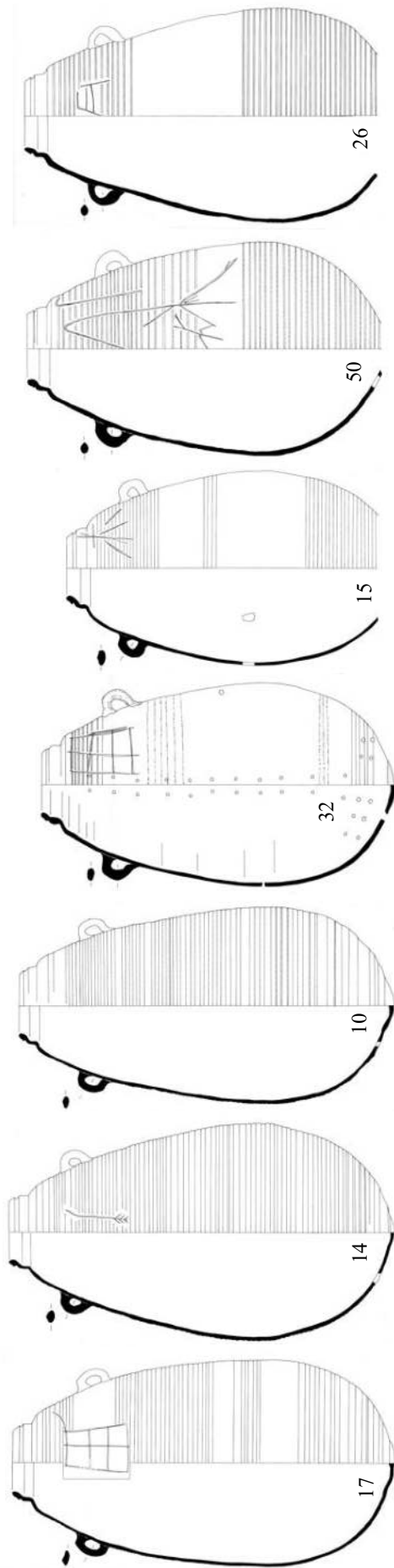
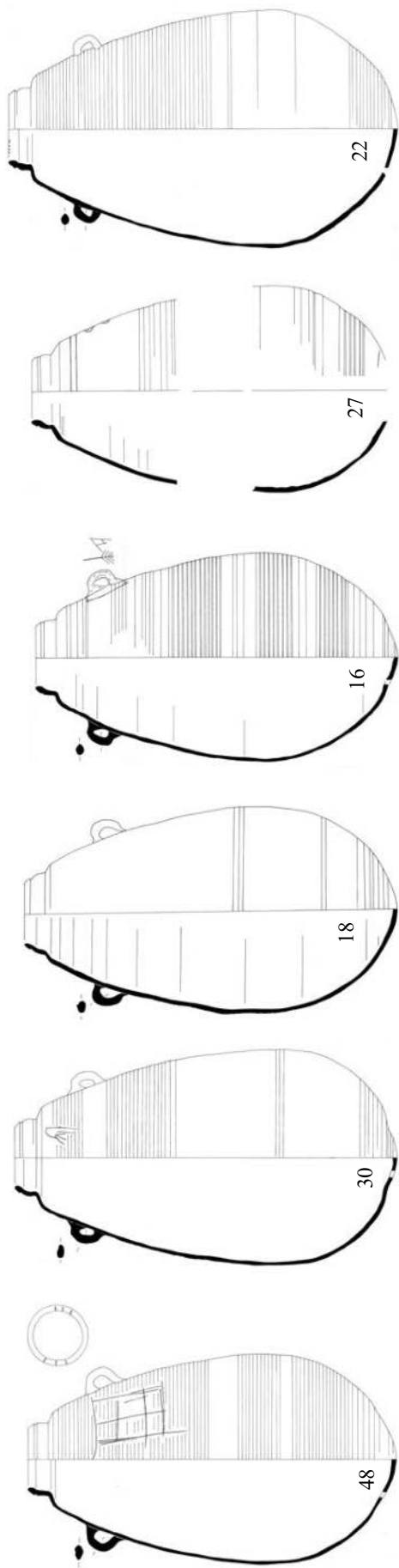

Figure 6.3. Amphiphora forms from Building F1, continued (scale 1:8).

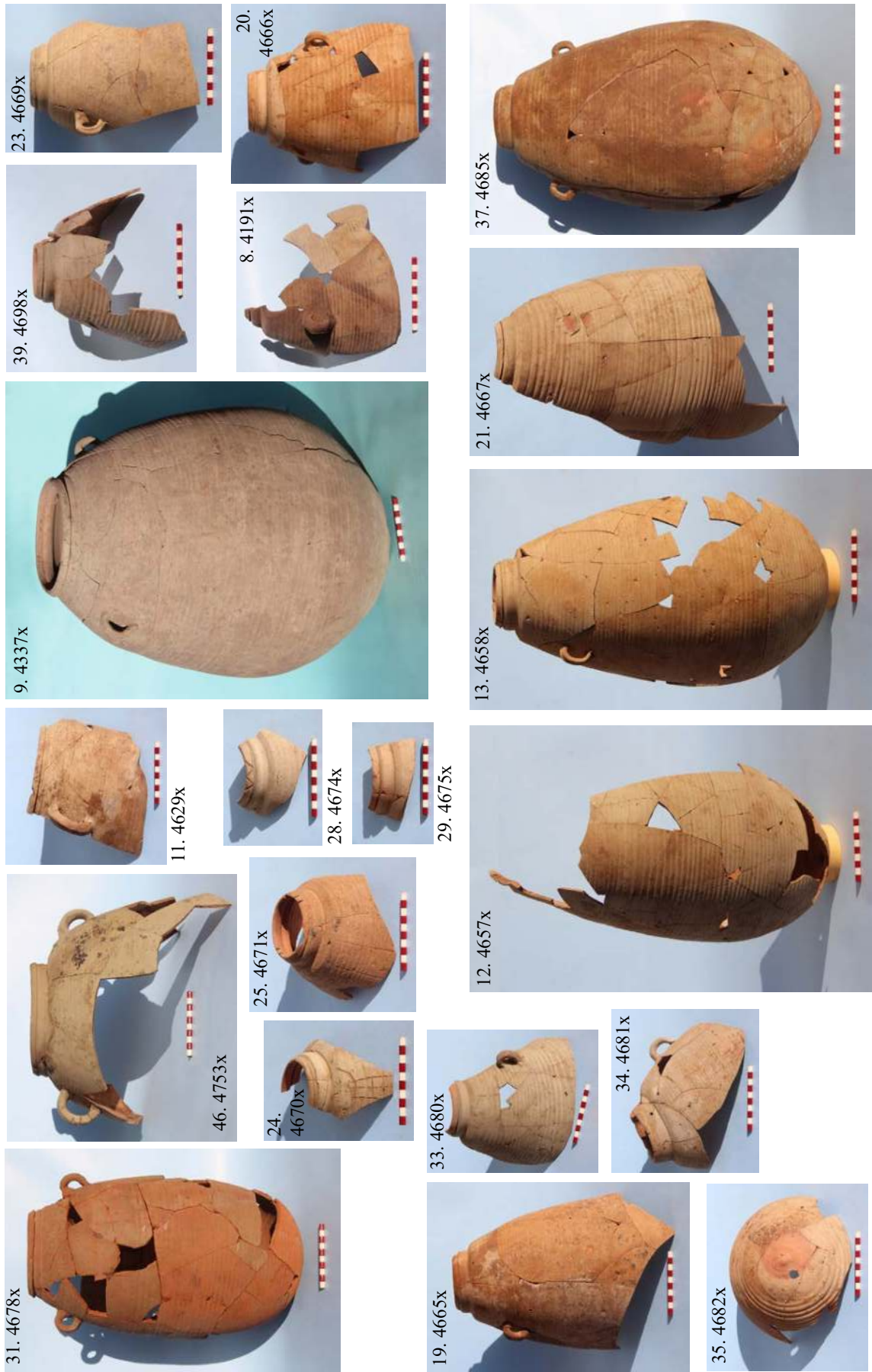

Plate 6.5. Some of the amphorae from Building F1 (cf. Figure 6.2). Note also (12) 4657-x; (13) 4658-x; (21) 4667-x; and (37) 4685-x; for which there are no drawings.



Plate 6.6. Some of the amphorae from Building F1 (cf. Figure 6.3).

TABLE 6.1. THE AMPHORAE AND GRAFFITI UNIQUE TO BUILDING F.I.

No.	Room	Form	Fab.	Sherd	D.	%	Ht	Wdt	R notch	B hole mm	Red circle	Oil stain	Surface	Int.	Dr.	Ph.	Graf.	Gm	Rep.
1	IX	4101	113	B											✓	-		326	
2	I, VI	4115	23	R	8-9	73									✓	-	-	135	
3	IX	4152	113	R	8	23									✓	-		75	
4	V, VI, VII	4160	102	B		205				✓ (2)	-				✓	-		512	
5	VIII, IX	4163	23	R	6	16									✓	-		10	
6	VI	4174	113	R	10	21									✓	-		90	
7	VI	4178	98	R	8	10									✓	-		18	
8	I, VI	4191	113	R	8	5						✓			✓	✓	234 TP	300+	
9	IX	4337	128	R	17	100	54.8+	44			✓		CR	P	✓	✓	133	8,125	
10	III	4626	102	PRO	7.5	100	49.6	27		✓ 9	✓		CR	P	✓	✓		2,360	
11	IV	4629	103	R	19	189	42+	39.9				✓	W	P	✓	✓	236	3,280	✓
12	II	4657	113	PRO	8.5	50	50.8	27.3		✓ 7	✓		GR	P/BR	-	✓	-	2,130	
13	III	4658	128	PRO	8	100	46.4	26.4					CR	P BR	-	✓	202 203	2,550	
14	III, IV, STR	4659	102	PRO	7.5	100	51	28.3		15.5	-		CR	P BR	✓	✓	196	2,550	
15	IV	4660	102	R	8	38	46+	28.5		1			CR	R	✓	✓	248 ²	1,100	
16	IV, VI	4662	103	PRO	7.7	85	47.1	27.7		post	✓	✓	CR/GR	R/BR	✓	✓	198 199 200	2,460	
17	II, III, IV	4663	113	PRO	8	100	51.1	28.7		3	✓		GR	R	✓	✓	189	2,350	
18	I, III, IV	4664	113	PRO	7.7	90	49.4	27.5		-	-		GR	GR	✓	✓	-	2,500	
19	IV, VI	4665	113	R	8	100	36.8+	26.4				✓	CR	R	✓	✓	183 186 187	3,280	
20	III	4666	103	R	8	100	23.6+						CR	R	✓	✓	204	600	
21	III	4667	102	PRO	8.3	100	52.2	28.3		11.5	-	✓	CR	BR/R	-	✓	225	2,640	
22	III, IV	4668	103	PRO	8	100	50.5	28		pre 7	-		Y	P	✓	✓	-	2,580	
23	IV, VI	4669	102	R	7.5	100	24+	26				✓	CR	P	✓	✓	260	1,095	
24	III, IV	4670	103	R	7.5	56							CR	P	✓	✓	205	75	
25	III	4671	102	R	8	100							CR	R/P	✓	✓	197	320	
26	IV, VI	4672	113	R	8	100	46.7+	27.5					GR	BR	✓	✓	206	2,180	
27	III, IV	4673 ⁴	103	R	8	43							CR	P	✓	✓		530	
28	IV	4674	103	R	8	37							W	R	✓	✓	226	75	
29	IV	4675	103	R	8	42							CR	R	✓	✓		45	
30	III, IV	4676 ⁵	113	PRO	8	100	49.7	28.5		post	✓	✓ ⁶	BR	R	✓	✓	264	2,780 ⁸	

¹ Irregular post-firing hole mid-body.

² Note similarity to 240g (4799x).

³ Part of base missing, not certain if there was a base hole.

⁴ Tiny vertical scratches on body - like a number of others - caused by padding in transport?

⁵ One handle planned down, as if to allow vessel fitting into a tight space, or possibly handle used as a whetstone?

⁶ Only one sherd oil-stained.

⁷ At most a sherd of 15gm missing from the vessel.

No.	Room	Form	Fab.	Sherd	D.	%	Ht	Wdt	R notch	B hole mm	Red circle	Oil stain	Surface	Int.	Dr.	Ph.	Graf.	Gm	Rep.
31	I, II, VI	4678	98	PRO	11.5	77	45	25.7		11	-		OR		✓		143 144	2,860	
32	IV, VI, STR	4679 ⁸	102	PRO	8	100	47+	27	✓	✓	✓		GR	P	✓		211	2,310 ⁹	✓
33	III	4680	128	R	8	42							GR	BR/P	✓		207 208	360	
34	II, IV	4681	113	R B	8.5	87			✓		✓		CR	R	✓		210	705	✓
35	III, IV	4682	103	B		70	20+	27.5		post	✓		Y	P	✓			580	
36	III, IV	4684	102	B			24.2+	26		post	✓		GR/W	R	✓			1,150	✓
37	I, II, III, IV	4685	102	PRO	7.5	100	50.2	27.8		20 x 23	✓ ¹⁰		GR	BR	-		217 219 265	2,440	
38	III, XII, STR	4686	103	B		100	26+	35		-	✓		CR/Y	R	✓			1,425	
39	I	4698	113	R	8	55							GR	R	✓		190 261	310	
40	XII	4706	98	R	12	23							CR/P	OR	✓	3.1.1		140	
41	IB	4716	102	R	14	11							CR	P	✓			30	
42	III	4739	102	R	14	85							CR	P	✓			515	
43	III	4740	102	R	15.4	100							CR	P	✓		218	610	✓
44	III	4741	128	R	13	40							CR		✓			80	
45	III	4742	128	R	9	37							CR	BG	✓		249	55	
46	I, II, III, IV	4753 ¹¹	128	R	16	52	44.8+	35							✓		230 TP	1,340	
47	III, IV	4754	-	R	8	50									✓			135	
48	III, IV, VII	4755	18	PRO	8	100	48	28.8	✓	13	✓		CR	R	✓		231	2,280	✓
49	F1	4756	18	R	22	27									✓			140	
50	I, II, III, VII, IX, STR	4816	103	R	8	19	47+	28.5		✓			CR	R	✓		250	785+	
51	III	4817	103	R	14	31							GR	P	✓			80	
	III	amph		BS				27.1							-			1,000	
	VI	amph	102	BS											✓		188	60	
	III	amph	102	BS									CR		✓		220	40	
	F1	amph	-	SH											✓		227	160	
	F1	amph	-	BS											✓		228		
	F1	amph	113	BS											✓		230a		✓
	IX	amph	102	BS B							✓				✓		232 TP	400	
	F1	amph	102	BS H											✓		233 TP	960	
	III	amph	102	BS									CR		✓		235	15	
	III, VIII	2826	102	R	8	34							GR	P	✓		213	280	✓

⁸ Particularly abraded and worn surfaces.

⁹ About 150gm of sherds missing.

¹⁰ Red area is irregular and off-centre: token only.

¹¹ Burnt and flaky surfaces, especially towards the base. Vessel reused as an 'oven'?

TABLE 6.2. NAPATAN AMPHORAE FORMS NOT UNIQUE TO BUILDING F1.

These are very fragmentary, hence some of the fields listed in Table 6.1 have been removed.

Rm	Form	Fab	Sherd	D.	%	B hole	Red circle	Surf.	Int.	Dr.	Gm	Rep.
VIII, IX	2415	102	R	8	83			CR		3.1.3	170	
III, VI	2415	113	R	8	25					3.1.3	30	
XII	2493	OF	R	9	18					3.1.3	40	
XII	2498	113	R	8	14			CR		3.1.3	80	
STR	2816	23	R	8	20			-		3.1.3	20	
VIII	2826	102	R	10	7					3.1.6	4	
IX	2826	113	R	9	18					3.1.6	50	
IX	2826	102	R	8	9					3.1.6	47	
III	3045	103	R	8	15			CR	R	3.1.2	20	
III	3284	113	B	-	100	✓		CR	BR	3.1.9	200	
III, IV	3284	102	B	-	50	✓	✓	CR	R	3.1.9	680	
III	3284	-	B	-	60	✓	✓	CR	R/P	3.1.9	160	✓
II	3412	102	R	17	9			CR		3.1.8	20	
VIII	3413	102	B	-	20			CR		3.1.9	35	
III, VI	3784	128	R	8	49					3.1.6	145	
VII, IX	3790	23	B	-		✓				3.1.9	18	
VIII	3790	102	B	-	20	✓				3.1.9	30	
III	3898	-	R	13	57			CR/P	OR	3.1.8	105	

7. The pottery finds from Site R18

Discussing the ceramic grave assemblages is problematic because the degree of disturbance caused by the grave robbers is such that in the majority of cases it is not certain what sherds belong to which grave, and often only rather abraded sherds were found. It is noteworthy that, despite the prestige implied by the pyramid superstructures, even in or near these graves relatively few sherds of fine wares were found. This suggests that during the robbing, especially of the more prestigious graves marked by a pyramid, the ceramic grave goods were removed intact.

Coarsewares (dishes, bowls and cooking pots) are common. Not so bread cones, although a few are present. Only two complete jars in a handmade, black slipped/ burnished ware were found, with impressed or rouletted decoration; these were however on their own, not accompanied by other ceramic wares. The larger of the two, 4335x (3.6.1/ Figure 7.4 & Plate 3.6.1), formed part of a drinking set, with a copper-alloy cup (cat. no. F-83) set in its mouth and a copper-alloy *clepsydra* (cat. no. F-86) placed close by (see Welsby and Taylor forth.; Welsby 2023f, pl. 11.174). Two incomplete vessels were found (4440x [3.6.1] and 4512x [3.12.5]), also with impressed decoration, but they are so far a rare occurrence in the cemetery, and at Kawa itself.

All of the 100 graves excavated are either Napatan or Meroitic in date, but with some residual Neolithic, *Kerma Ancien* and *Classique* pottery types, and one probably Post-Medieval jar sherd [(JE3)1, topsoil, 3539x]. There are a few relatively undisturbed graves (for example, Napatan: (GD3)38 and 98; Meroitic, (HA1)1075 and (JH3)116). Unfortunately in most of the instances where the grave goods survived more or less intact, the graves only contained one or two different forms, making it problematic to date the many other forms found across R18 by association. Twenty-two graves contained no pottery at all, while 11 only yielded body sherds and are therefore difficult or at least unreliable to date, but based on the type of fabric and surface treatment it is likely that they are of Meroitic date, *assuming that the sherds belong to the grave they were found in*. In other graves the vessel fragments were found either in robber pits or the descendary fill, and therefore do not actually date the burial itself with any certainty; the fills of the robber pits could contain sherds of broken vessels from the grave, but also random sherds from other graves, whereas pottery in the descendary fills should theoretically at least contain random sherds predating the grave, or alternatively sherds of vessels associated with funerary rituals at the time of the interment. That said, a few complete vessels were found in the descendaries, such as the *unguentarium* 3693x in grave (JH3)2 and incense burner 3698x in grave (JG2)2. In a few cases sherds found in the descendary fill and robber pits joined, not surprising as the robber pits usually cut through the descendary fills to gain access to the burial chambers.

Generally there is no link between the sherds found in the original grave fills and the later contexts. Large jar sherds were occasionally used as spade sherds, presumably by the grave robbers, but as these are often found on their own, without the rest of the sherds belonging to the same vessel,

there is no reason to suppose that they originally belonged to the grave they were found in. They do, however, belong to types of jars present as grave goods (slipped beer jars or coarseware jars with narrow necks) in other graves, so were probably found within the cemetery by the grave robbers.

As some of the graves contained more than one body, not inhumed at the same time, it is also possible that the grave goods belong to different dates, being placed in the grave at the time of each subsequent burial, but the time gap is unlikely to affect significantly the dating of the different vessels by association, as the dating is at best rather broad.

Looking at the better preserved assemblages, in the Meroitic period graves contained at least one closed vessel, usually a beer jar, as well as a bowl, cup or beaker. The same type of assemblage was the norm in the Napatan period, with an amphora instead of the later beer jar form. At least one dish and a handmade narrow necked jar also occur in association with some graves. A cup would often be placed over the mouth of one of the beer jars, either right way up or upside down. Within the current excavations these were not of similar wares (some of the cups are made of copper alloy) and thus did not form a set. However, in grave (KE5) 8, excavated in 1993 and published in 2001 (Welsby 2001, 225 & figs 5.15 & 5.51), the grave goods included a jar, J19.1, and a cup, C1.1, that were similar, both in fabric and surface finish (Plate 7.1). Copper-alloy vessels, especially



Plate 7.1. Jar and cup set, R18 grave (KE5)8.

bowls or cups as mentioned above completed the array of grave goods, so that a bowl could be made of either material.

These observations are based on a tiny number of graves of some status, and we might expect the graves of the more humble of Kawa's inhabitants to have been less well appointed. The degree of disturbance caused by grave robbers means that we cannot draw many conclusions as to the original funerary assemblages, although the amount of robbing would suggest that at least some of the grave goods were considered highly desirable.¹ Nevertheless,

¹ Alternatively, the graves at Kawa were simply not very rich, despite the status implied by the pyramid superstructures. If so, the grave robbers were not aware of this, to judge by the degree of disturbance and destruction that they wrought in their search for valuable grave goods.

the contrast between the grave goods of the less-disturbed graves and the quantity and quality of finds within the contemporary cemetery at Sedeinga is striking.

While there are almost equal amounts of handmade and wheel-made sherds, the weight of the wheel-made is almost three times greater, and there are slightly more than twice as many wheel-made rims and bases represented than there are from handmade vessels. See also Table 2.1 and the fabric descriptions in Chapter 2 for information on the fabrics present.

Apart from the forms that we can be confident comprised part of the grave assemblages, there are a number of forms that recur throughout the cemetery, but are found either in the robber pit fills or in other contexts that cannot be securely related to any particular grave. They may have been placed by the graves rather than in them, but the common nature of the forms (mainly handmade) – coarse closed jars, hemispherical bowls, coarseware dishes and incense burners, suggests that they may belong to the Kushite funerary repertory (Figures 7.6-7.7).

For a information of the proportion and quantities of different fabrics, method of manufacture and wares featuring at the cemetery, see Chapters 2, 8 and 9.

Conclusion

The majority of graves that can be dated are Meroitic; in some of the disturbed graves the pottery seems to be a mixture of both periods, not surprising as there are graves of Napatan date within the cemetery, and clearly tombs were robbed intentionally, or cut into by later burials and their contents looted, throughout the history of the cemetery.

The surviving complete or reconstructed beer jars are of two types, as illustrated by 2881x (3.2.6) and 2882x (3.2.4), but decorated sherds of another ware also feature [1261y (JF2)23 and 1283y (JF1)26, Plate 4.3], unfortunately not relatable to a particular rim form.

Strikingly few white eggshell ware-cups occur in the graves excavated; fragments of at most 15 vessels weighing less than half a kilo were recovered, including a complete cup, 4785x (3.6.2), weighing 150gm.

The most notable import from outside the Nile Valley is undoubtedly form 4338x (3.2.1), the table version of a Dressel 2-4 amphora from Campania, followed by the two *unguentaria* (3693x, 3.2.11), which may come from Asia Minor.

A look at the pottery found in the course of the surface survey of the cemetery in 1993 (Welsby Sjöström 2001, *passim*) shows a very similar range of forms, though none particularly notable, apart from the decorated rim of a cup in Fabric 26 (*ibid.*, fig. 5.45, BO12.4, decoration D60.4).

Presentation of the pottery belonging to the graves

Bold – denotes vessels that were found complete or nearly so. Burials where the grave goods were recovered reasonably intact had nevertheless also been disturbed and may have originally contained more vessels.

* – Forms marked with an asterisk (*) illustrate the form, not the actual sherd/vessel found in the context; such drawings have been adapted from the original where necessary to show the length of profile surviving, displaying only the decoration or surface finish present in the relevant context. When not part of the grave assemblage and thus not illustrated, they are also listed with an asterisk in the tables below.

Individual graves

See Table 7.1 and Plate 7.1

(KE5)8 – Excavated in the course of the NDRS (Welsby 2001, 225).

483 – Contained only one body sherd of an abraded handmade jar with traces of red slip on the exterior, found amongst mud-brick rubble; undatable.

533 – Fragmentary and abraded pottery, probably Meroitic judging by the fabrics involved.

561 – A disturbed grave, but the combination of graffiti on a beer jar sherd and a nearly complete red slipped marl bowl suggest a Meroitic date, despite the presence of a *Kerma Ancien* rim in the robber pit fill.

Grid square (GD3)

See Table 7.2, Figures 7.1 and 7.2 and Plates 7.2 and 7.3.

(GD3) topsoil: a mixture of Meroitic (4788x (3.6.2), 4805x (3.7.1), 1275y (4.5), 1277y [4.7]) and some possible Napatan (2728x (3.8.15), 3255x (3.10.3), 2693x (3.11.7) rims, as well as 3140x (3.3.6) and 4793x (3.6.3). Note that in the case of 4795x (3.6.2) joining sherds were found in the

TABLE 7.1. INDIVIDUAL GRAVES.

Individual graves	Grave goods	Grave Fill	DF	RPF	Date/Comment
(KE5)8	J19.1, C1.1 ²				Meroitic
483					? 1 BS only
533	-	2518x (3.7.22) *2561x (3.12.2)	*2042x HS only (3.12.3) 2247xa 53g (3.8.16, 5.2)	2713x (3.3.2) *3241x (3.8.1)	Meroitic?
561	-		BU2.16 (3.6.1) *2231x (3.12.3) *3440x 1222y (3.6.5, 4.5) 54g (5.8)	*2045x (3.6.3) x 2 2712x (3.6.2)	Meroitic

² Published in Welsby Sjöström 2001, figs 5.15 and 5.51, Fabric 29.

TABLE 7.2. GRAVES IN GRID SQUARE (GD3).

Graves	Grave goods	Grave fill	DF	RPF	Date/Comment
Topsoil					Napatan & Meroitic
3				BS	? BS only
7		BS		BS	Meroitic? BS only
11	*3858x (3.7.6) 4781x (3.6.2) 4784x (3.2.11)	*2656x (3.7.3) *3831x (3.7.6) *3834x (3.7.3) *3880x (3.7.4)		*3411x (3.9.1) *3754x (3.7.7) *4780x (3.10.2) x 2	Napatan 8 th -6 th centuries BC
16					No pottery
20	4803x (3.2.7) 4804x (3.2.7)	*2410x (3.8.18)			Meroitic 1 st century BC
38	4780x (3.10.2) 4798x (3.1.10) 4799x (3.1.4)			*3776x (3.8.13) 4790x (3.8.10)	Napatan 25 th -26 th Dynasty
41		*4046x (3.12.2)		*3255x (3.10.3) *3381x (3.6.3) *3440x (3.6.3)	NAP
45	4785x (3.6.2) 4786x (3.2.9) 4802x (3.2.10)	*3942x (3.6.3)		4797x (3.1.10)	Meroitic 1 st -3 rd centuries AD
51		4792x (3.2.1)			Meroitic 1 st BC-2 nd centuries AD
55				*2509x (3.7.7) 4791x (3.3.5) 1279y (4.7)	Napatan/Meroitic
60		BS			? BS only
63	4801x (3.7.1)	4794x (3.3.3)			Meroitic
84					No pottery
87					No pottery
95		*2655x (3.11.7) *2893x (3.7.10) *4503x (3.8.6) 4789x (3.3.3) 4796x (3.2.2)			Napatan
98	4782x (3.6.2) 4783x (3.7.5) 4787x (3.2.2) 4800x (3.1.4)	*3255x (10.3)			Napatan 7 th century BC, 25 th -26 th Dynasties
109					No pottery
112		*3716x 1142y (3.8.16, 4.2)			Napatan?
118					BS only
119 or 136				*2130x (3.8.17) *3235x (3.10.7) *3802x (3.10.7) *3816x (3.7.7) 4795x (3.6.2)	Napatan?
130					No pottery
133					No pottery
138		*2604x (3.7.20) *3443x (3.8.4) *3468x (3.8.1)		*2656x (3.7.3) *2767x (3.7.10) *3843x (3.7.3) *4630x (3.7.5) 4805x (3.7.1)	Napatan? 4630x = 8 th -7 th centuries BC
143					No pottery

robber pit fills of graves 123 and 138, in the grave fill of Grave 20 as well as in the topsoil.

(GD3)11 – Napatan. The grave goods (79A-C) consist of a small pilgrim bottle and two cups/bowls, red rimmed; the grave fill contains more RBRIE rims and the robber pit fill the same.

(GD3)20 – Meroitic. Two slipped beer jars with painted decoration (147B and C); the grave fill contains a fragmentary shallow coarseware dish.

(GD3)38 – Napatan. One amphora, a wheel-made cup (base mould-made) with RBRIE, and a hemispherical base, incomplete, possibly reused as a bowl (83A-C).

(GD3)41 – Grave fill contains the base of a wheel-made jar. Neolithic bowl rim in the robber pit.

(GD3)45 – Meroitic. A tall, narrow-necked, wheel-made jar, a smaller jar, also with narrow simple neck, and a Meroitic cup with painted decoration, the only complete such vessel to be found in the course of the excavations at Kawa, (70A-C). A wide-mouthed bowl was found in the grave fill (46). However, note Napatan period rim 4797x in the robber pit fill.

(GD3)51 – The grave fill contains the base of a barrel-shaped wheel-made vessel, with a white-slipped interior.

(GD3)63 – Napatan? A single handmade jar with a red band around the neck and a similar, but coarser, vessel found in fragments both in the grave fill and by the mud-brick blocking, with some sherds joining examples in context 21, in the fill of grave (GD3)20.

(GD3)95 – Napatan? Base of a ribbed amphora, most likely Napatan, and handmade jar. 4789x was found in the grave fill. Part of 4796x was found in layer 21, fill of grave (GD3)20.

(GD3)98 – Napatan. The grave goods consist of an amphora, a wide-necked slipped jar and two cups, both wheel-made, one RBRIE.

(GD3)112 – Napatan? Shallow handmade dish with scalloped decoration on the rim.

(GD3)118 – Body sherds only, in backfill of grave, probably Meroitic.

(GD3)119/136 – Fragments of cup rim 4795x were also found in the fill of grave (GD3)20 and in the topsoil.

(GD3)138 – Grave fill contains fragments of a handmade cooking pot, a cup and a wheel-made dish. The robber pit fill contains fragments of Napatan RBRIE bowls and cups.

Area (HA1)

More detailed data is presented in Table 7.3, Figure 7.2 and Plate 7.3.

(HA1)1052 – Probably Meroitic.

(HA1)1066 – ? Fragment of open dish.

(HA1)1075 – Meroitic. Fill of chamber contains four beer jars, placed above the two skeletons. One jar has a tall, inward-sloping plain rim and three with beaded rims and decorated with brown/black bands; 2883x has graffiti 62g on or just below the shoulder. Base sherds of a similar vessel were also found, with abraded edges, presumably used for digging through the fill by the robbers, and the rim of a coarseware pot, and in the grave fill a crude ring-footed base.

(HA1)1096 – Probably Meroitic

(HA1)1097 – Fragment of a handmade dish in the grave fill.

(HA1)1098 – Grave fill contains fragments of a small bowl or cup and the rim of a bread cone

Grid square (HA2)

Topsoil: 2011x (3.7.5), 2025xc (3.7.9), 2102x (3.5.11), 2169x (3.7.23), 2183x (3.1.10), 2240x (3.10.6), 2280x (3.11.7), 2227x (3.8.11), 2292x (3.6.3), 2327x (3.7.21), 2490x (3.1.5), 2519x (3.12.1), 2681x (3.6.3), 3143x (3.6.2), 3146x (3.6.1), 3147x (3.6.1), 3153x (3.6.11), 3246x (3.10.3), 3370x (3.6.2), 3500x (3.7.11), 3537x (3.1.2), 3616x (3.2.8), 3696x (3.6.3), 70g (5.4), 4326x (3.2.6), 4401x (3.8.11), 4633x (3.8.5), BU2.16 D25.9 (3.6.1). These are mainly Meroitic, but some Napatan also feature. 3146x and 3147x (3.6.1) appear to be Neolithic in date, to judge from their fabric and decoration; they could alternatively be Meroitic, but their fragmentary nature makes it difficult to be certain. There are also a handful of *Kerma Ancien* sherds, such as BU2.16 as well as red- and black-burnished body sherds, probably also of Kerma date. See Table 7.4 and Figure 7.3 for the grave goods from the better preserved graves.

(HA2)20 – unexcavated.

(HA2)23 – One wall sherd with impressed decoration, most

TABLE 7.3. GRAVES IN AREA (HA1).

Grave	Grave goods	Grave fill	DF	RPF	Date/Comment
1052		BS			Meroitic? BS only
1055				BS	? BS only
1059					No pottery
1066		*2537x (3.7.21)			?
1075	2881x (3.2.6) 2882x (3.2.4) 2883x (3.2.4) 2884x (3.2.4)	*2124xb (3.7.15) 2848x (3.11.5)			Meroitic 2 nd - (1 st ?) century BC
1082					No pottery
1083				*2466x (3.8.17)	Napatan?
1084			2622x (3.11.8) 2850x (3.11.9) 2850xa (3.11.9)	2849x (3.8.6)	Meroitic, 2 nd century BC?
1093					No pottery
1096				BS	Meroitic? BS only
1097		*2067x (3.8.17)			Early 4 th century BC?
1098		*2235x (3.6.2) *4320x (3.11.7)		*3716x 1142y (3.8.16, 4.2)	Meroitic ?

TABLE 7.4. THE GRAVES IN GRID SQUARE (HA2).

Grave	Grave goods	Grave fill	DF	RPF	Date/Comment
20					No pottery
23				*1118y (4.5)	Meroitic?
31		*2011x (3.7.5) *2314x (3.8.17) *2689x (3.10.1)			? Kushite
39		3500x (3.7.11)			Meroitic
55		3535x (3.6.2)	3153x (3.6.11)	3145x 1112y (3.6.1, 4.2)	Meroitic
58		3501x (3.3.7)		*2586x (3.10.5) *2635x (3.10.2) *1117y (4.5)	Napatan late 7 th -mid 6 th centuries BC
62	-			*2682x (3.10.7)	Napatan?
64					No pottery
67/229	3538x (3.2.8)	*2644x (3.6.7)	3518x (3.6.3) 3616x (3.2.8) 3619x (3.7.20) 3620x (3.10.7) 3621x (3.6.2)		Meroitic
71		*2697x (3.5.4)			Napatan?
79		*3085x (3.6.07) 3503x (3.6.3) 3520x (3.10.7) 3950x (3.6.4)		*2655x (3.11.7) 3152x (3.6.3) *3420x (3.6.3) 3511x (3.10.7)	Napatan?
83		*2310x (3.7.8) *3500x (3.7.11) 3534x (3.7.21) *3950x (3.6.4)			Early Meroitic?
90		*2694x (3.12.1) 3149x 1116y (3.6.11, 4.4)			Meroitic?
94		*2045x (3.6.3) *2492x (3.10.2) 3148x (3.3.6) 3613x (3.7.22) 4375x (3.7.11)			Kushite
96					No pottery
100					Meroitic? BS only
112					No pottery
116	*2317x (3.10.5)	3615x (3.12.2)			Meroitic?
119		*2292x (3.6.3) 3150x (3.10.4)			Napatan
161		*2955x (3.10.3)			Napatan
204				*2039x (3.8.4) *2045x (3.6.3) *2345x (3.7.8) *2561x (3.12.2) 3154x (3.6.3) 3155x (3.3.3) 3156x (3.6.12) 3157x (3.2.10)	Meroitic
207			*2042x (3.12.3) *2655x (3.11.7) 3529x (3.10.3) 3530x (3.4.11) 3531x (3.4.3) 3532x (3.4.1) 3533x (3.6.2) 3616x (3.2.8)		Napatan & Meroitic Descendary fill 4 th century BC

TABLE 7.4. THE GRAVES IN GRID SQUARE (HA2) (CONT.).

Grave	Grave goods	Grave fill	DF	RPF	Date/Comment
213		*2310x (3.7.8) *2421x (3.7.21) *2869x (3.7.7) 3862x (3.7.4)	3624x (3.6.11) *1000y (4.1)	3527x (3.6.2)	Meroitic
215		3280x (3.4.2)		*3503x (3.6.3) 3525x (3.4.3)	Napatan 7 th -6 th centuries BC
282	*3151x (3.10.6)				

likely residual *Kerma Ancien*, with red burnished exterior and black slipped interior, fabric 6.

(HA2)31 – Grave fill contains a handmade dish and fragments of a beaker and small bowl, red-washed on the interior. As the forms are incomplete, their identification as belonging to a beaker and a flat-based dish are not definite.

(HA2)39 – Grave fill contains rims of two closed bowls/cooking pots.

(HA2)55 – Rim of a black-slipped, wheel-made Meroitic cup was found in the grave fill; a residual rim of possibly Neolithic date was found in the descendentary fill.

(HA2)58 – The rim of a handmade closed jar, 3501x, reused as a spade sherd, was found in the grave fill, together with a large jar body sherd, also used as a spade sherd.

(HA2)67/229 – This grave contains two burials, one secondary. Apart from jar 3538x, the rest of the pottery found in the grave fill is very fragmentary. If they were broken *in situ* many of the parts of the pots have somehow disappeared in the course of the robbing (subsequent phases of robbing?). Parts of two other jars were found; the shoulders and part of the body of 3616x (parts of which were found in both the original grave fill and the fill of the secondary burial), and part of the hemispherical base of a beer jar or similar. A cup, a dish, three bowls and a cooking pot rim were also found in the grave fill. It was not possible to distinguish between the grave goods belonging to either skeleton, as joining sherds were found in the respective contexts.

(HA2)71 – Rim of a basin or deep open-mouthed jar.

(HA2)79 – Two rims, one of a dish and the other of a bowl with grooves by the rim externally.

(HA2)83 – The grave and chamber fill contained two cooking pots with inverted rims, a beaker (?) and a bowl with everted rim.

(HA2)90 – Part of a hemispherical bowl with beaded rim and a graffito or decoration on the interior. Also the base of a wheel-made beaker (?).

(HA2)94 – Two cups (one a beaker?), a handmade bowl with basket impression 200y and a closed handmade jar, all fragmentary. Jar rim 3148x was found within three different contexts.

(HA2)100 – A few undatable body sherds in the grave fill, including one that could be residual Kerma period, or a variant of a quartz rich and slipped handmade Meroitic ware.

(HA2)116 – Grave goods, one complete offering cup with traces of burning and a coarse thick-walled flat base in the chamber fill.

(HA2)119 – In the chamber fill the base of a beaker and the rim of a dish were found.

(HA2)204 – Only fragments of vessels (cooking pot, fineware cups, a basin and a narrow-necked, handmade jar)

were found in the robber pit fill.

(HA2)213 – In the alluvium fill of the grave chambers, sherds of two closed cups and two open bowls, plus a large wall sherd of a handmade basin with a piecrust lug. A nearly complete beaker was found in the robber pit fill.

(HA2)215 – The chamber fill contained the rim of a wheel-made basin with piecrust lug, in the Napatan tradition.

(HA2)282 – A nearly complete flat-based offering dish by the skeleton.

Area J

This area contains the highest-status grave monuments, stone pyramids S1-S6 and mud-brick pyramids M1-M11 (see Welsby 2023f). However, grid squares (JC2), (JC3), (JD2), (JD3), (JE2) and (JE3) are very disturbed and thus the provenance of the finds rarely conforms to the grave/descendentary/robber pit pattern. Instead there are pottery sherds found in pit fills, near or within the (collapsed) superstructures/grave monuments, all in a fragmentary and eroded state, and it is impossible to say what originally belonged to a given tomb, nor has it been possible to reconstruct many vessels in their entirety (or even partially) from graves in these areas. There are, however, two notable exceptions: grave (JG1)12 (Pyramid M6) and grave (JG2)2 (Pyramid M1). In grid squares (JH3) graves 21, 39, 43 and 116 and grave (JI4)1 ceramic grave goods were found more or less intact, but these latter graves do not have any surviving grave monuments, and other graves in the area had fared less well. The surfaces (under the topsoil/sand) contain pottery sherds that are mostly Meroitic in date.

The following forms were found amongst the disturbed parts of Area J (Table 7.5, Figures 7.3-7.5 & Plate 7.4). The topsoil throughout the area contains fragments of both Napatan and Meroitic pottery.

S5 (JC3)12 – Included here are finds from grid squares (JC2) and (JD2), but all are related to the same grave. Unfortunately none of the contexts that can with confidence be related to this grave contain diagnostic forms. A decorated handle, 4512x, with decoration 1234y and rim 4824x, with decoration 1284y were found in the construction surface under the descendentary upcast. A fragment of dish form 3969x was recovered from the compacted construction surface on the west side of Pyramid S5, all of the above in grid square (JD2). (JC2) includes construction surfaces and an alluvium and sandstone deposit, containing coarseware jar and bowl rims, none particularly diagnostic or datable, except for being Kushite.

M9 (JD2)40 – Form 3969x was found amongst the compact sand/alluvium over pyramid M9's collapse; forms 4765x-4771x were found in the rubble/collapse around

TABLE 7.5. GRAVES IN AREA J, WITH AND WITHOUT MONUMENTS.

Mon.	Grave no.	Grave goods	DF	RPF	Date
S5	(JC3)12			*3714x (3.8.6)	Kushite/Meroitic 2 nd -1 st centuries BC?
M9	(JD2)40			*2321x (3.8.6)	Meroitic
M8	(JE2)14		*3094x (3.6.3)		Kushite
S1	(JE3)69				Meroitic?
S2	(JE3)115		3579x (3.2.7)	3558x (3.2.10)	Meroitic late 1 st century BC
S3	(JE3)132				?
-	(JF1)23		*2039x (3.8.4) *2624x (3.4.6) *4475x(3.7.12) *4538x (3.7.14) 4821x (3.7.24)	4821x (3.7.24) 1283y (4.8)	Napatan? & Meroitic 2 nd century BC
-	(JF2)2	4653x (3.2.10)			Meroitic 1 st -2 nd centuries AD
S6	(JF2)20			1261y (4.10)	Meroitic BS
-	(JF2)26				? BS
-	(JF2)27				? BS
S4	(JF2)55		*3616x (3.2.8) 4098xb (3.12.2) 4550x (3.11.10) 4825x (3.8.4) 4832x (3.6.2) 1263y (4.7)	*3124x (3.11.8)	Meroitic
-	(JF2)79	4540x (3.6.5)			Meroitic 1 st century AD
M6	(JG1)12	4551x (3.2.6) 4552x (3.3.2) 4654x (3.11.7)		*2039x (3.8.4) *2893x (3.7.10) *3101x (3.8.4) 4445x (3.11.2)	Meroitic
M7	(JG1)31		4510x (3.7.8) 4562x (3.7.12) 4822x (3.12.3)	4507x (3.8.10) 4355x (3.8.10)	Early Meroitic?
M1	(JG2)2	4338x (3.2.1)		*2025xc (3.7.9) *2310x (3.7.8) 3696x (3.6.3) 3697x (3.6.1) 3698x (3.11.4) 3699x (3.6.2) *3837x (3.3.5)	Meroitic early 1 st century AD
-	(JG2)33				Meroitic? BS only
M2	(JG2)150	4494x 1231y (3.3.4, 4.2)		*2878x (3.12.1) *3460x (3.7.4) 1206y (4.6) 1282y (4.6) 161g (5.1)	Napatan?
M4	(JG2)171		*2893x (3.7.10) 4442x (3.6.6)		DF early Meroitic?
M3	(JG2)175		*2039x (3.8.4) *2642x (3.8.10) 4438x (3.3.3) 4439x (3.2.1) 4440x (3.6.1)	*2339x (3.8.5) *2790xa (3.6.2) *4355x (3.8.10) 4438x (3.3.3) 4440x (3.6.1)	Meroitic
-	(JG2)231				BS only
-	(JG2)244	4444x (3.4.10)		4443x (3.3.5)	Meroitic 3 rd -2 nd centuries BC
-	(JG2)282				
-	(JG3)				No pottery
-	(JG4)				No pottery
-	(JH3)5			Spade sherd	
-	(JH3)9		BS		Meroitic? BS only
-	(JH3)11			3689x (3.8.4)	?
-	(JH3)21	4335x (3.6.1)			Meroitic 1 st century AD?
-	(JH3)36		*2881x 1173y (3.2.6) 3692x (3.8.11) 4475x (3.7.12)		Meroitic 2 nd century BC
-	(JH3)39	4327x (3.2.4) 4331x (3.6.12) 4332x (3.10.2) 4333x (3.2.10) 4334x (3.6.2) 3690x (3.2.6)		3690x (3.2.6)	Meroitic

TABLE 7.5. GRAVES IN AREA J, WITH AND WITHOUT MONUMENTS (CONT.).

Mon.	Grave no.	Grave goods	DF	RPF	Date
-	(JH3)43	3694x (3.2.5) 3695x (3.2.6)	3693x (3.2.11) x 2		Meroitic 1 st century BC
-	(JH3)69			*2881x (neck only) (3.2.6)	Meroitic 2 nd -1 st centuries BC
-	(JH3)110				Meroitic? BS only
-	(JH3)114				Meroitic? BS only
-	(JH3)116	4326x (3.2.6) 4328x (3.2.5) 4329x (3.2.5) 4330x (3.2.6)			Meroitic 2 nd -1 st centuries BC
-	(JH4)				Meroitic All BS
-	(JI4)1	4336x (3.6.1)			Meroitic late 2 nd century BC?

the pyramid. 4820x (JD2)80 comes from the construction layer near the descandary. The shoulder of a Levantine amphora, possibly of form 2657x (JD2)49, was found in a pit to the north of the monument, and a few Napatan amphora sherds (very abraded) were amongst the pottery in the layer over the collapsed grave monument. Otherwise all pottery appears to be Meroitic in character (fabric and surface treatment), but a set of grave goods could not be reconstructed, and with the exception of 2321x in the robber pit fill, everything else was found close to the surface and over the denuded superstructure.

M8 (JE2)14 – Basin 4763x was found in a pit to the west of the grave monument. Around and over the grave monument are rim sherds of coarseware bowls and cooking pots, mostly of uncertain date, but including one possible Napatan amphora sherd and a Kerma period bowl; none of these are likely to belong to the grave.

S1 (JE3)69 – A rim of bowl form 3547x (3.7.14) was found in the robber spoil, possibly Meroitic.

S2 (JE3)115 – The rim and shoulders of jar 3543x (3.2.8) was found in a gravel deposit by Pyramid S2, joining to sherds in the topsoil, together with a decorated jar sherd (1135y, 4.9), belonging to a different vessel. The fragmentary profile of a *Kerma Classique* beaker was found near the robber spoil, among Kushite sherds (JE3)24. Napatan amphorae sherds were found in the rubble and sand near the superstructure. The most interesting forms, most likely imported, are 3579x and 3558x, found in pieces in the descandary fill (the former) and the latter in the robber pit fill and topsoil. In view of their uniqueness at Kawa they are both illustrated here, although they do not fit the criteria of grave goods of this tomb.

S3 (JE3)132 – Within the pyramid core, a Napatan coarseware rim, 3225x.

(JF1)23 – 1283y (decorated beer jar shoulder) was found in the robber pit fill. Fragments of 4821x were found in both the descandary and robber pit fills.

(JF2)2 – Complete red-slipped, wheel-made jar

S6 (JF2)20 – Meroitic date, mostly body sherds found within monument. Nearby were 3570x and 4764x with decoration 1263y, Meroitic, 2nd-1st centuries BC, but not found in grave fill; 4764x joins to sherds in grave (JF2)55.

(JF2)26 – Body sherds only, undatable.

(JF2)27 – Body sherds only, undatable.

S4 (JF2)55 – 4825x is from the descandary upcast. Beaker form 4827x and beer jar rim *2882x were found in a shallow pit nearby (JE2)4. They have dramatically different dates, the former 8th century BC and the latter 2nd-1st centuries BC.

(JF2)79 – Complete large wheel-made bowl with ring foot and red slip by rim.

M6 (JG1)12 – Meroitic. A tall and slender pot stand and an ovular jar with angular beading at the rim; higher up in the fill a complete handmade jar with narrow mouth, no neck and globular body. However, two Napatan amphora rims 2826x and 2912x and two Napatan coarseware rims, 2765x and 4711x, were found in the deposit over the north wall of the monument – suggesting the presence of a Napatan grave in the area.

M7 (JG1)31 – Apart from a ring-footed base, the other sherds belong to coarseware bowls and cannot be dated closely, and none were in any case recovered from a secure context.

M1 (JG2)2 – Meroitic. Dressel 2-4 amphora, table size, 1st century AD. The robber pit fills contained a complete handmade incense burner with a solid stem/base, the rim fragment of a fine stamped cup and the profile of a larger cup of *Kerma Classique* date.

M2 (JG2)150 – From the fills of the construction trenches of the north, west and south walls: *2022xb, *2050xb, *2328x, *2329x 200y, *3490x, *3716x, *3814x, *4355x. Some Napatan amphora body sherds were found in the robber pit fill and one in the chamber fill. Jar rim 4494x that was found in the grave fill seems unlikely to have been part of the actual grave goods.

M4 (JG2)171 – The only datable pottery recovered was from the descandary fill; a Napatan-style bread cone and the rim of a Meroitic fineware cup.

M3(JG2)175 – Jar 4438x was found in five different contexts, mostly within the descandary fill but one sherd in the topsoil. Bowl 4440x was found in four contexts, within the descandary fill, robber pit fill and in the tomb collapse; a much disturbed burial.

(JG2)33 – Body sherds only, Meroitic?

(JG2)231 – Body sherds only.

(JG2)244 – Parts of basin 4444x were found both in the grave and robber pit fills.

(JG2)282 – No pottery.

(JG3) No pottery was found in this grid square.

(JG4) No pottery was found in this grid square.

(JH3)5 – Spade sherds from the base of a Meroitic beer jar, like 2881x (from the robber pit fill).

(JH3)9 – Body sherds only, Meroitic in character (fabric, surface treatment).

(JH3)11 – Body sherds only, undatable.

(JH3)21 – Meroitic. Black slipped and comb decorated handmade jar.

(JH3)36 – The only pottery was found in the descendary fill, Meroitic in date.

(JH3)39 – Meroitic. Rim, neck and shoulders of a beer jar in the chamber fill, complete (?) assemblage of beer jar, cup, beaker, ring-footed bowl and painted jar in chamber.

(JH3)43 – Meroitic, two decorated beer jars and two *unguentaria* in the descendary fills (one complete, the other only rim surviving). Also a sherd from another beer jar.

(JH3)69 – Neck of a beer jar of type 2881x in robber pit fill, dated to 2nd-1st centuries BC.

(JH3)110 – Body sherds only, Meroitic in character (fabric, surface treatment).

(JH3)114 – Body sherds only, Meroitic in character (fabric, surface treatment).

(JH3)116 – Meroitic. Grave assemblage of four beer jars, three with beaded rim and painted band and or decoration, one with plain, inward sloping rim, with a copper-alloy bowl (Welsby and Taylor forth., cat. no. F-84) as a lid.

(JH4) All body sherds; in the topsoil, there are Meroitic body sherds of a jar with red slip and bowl in Fabric 53, from Aswan?

(J14)1 – Meroitic. One small black-slipped jar with impressed decoration, vertical neck and rim broken away and not possible to reattach. Note the similarity to 4333x (from grave (JH3)39, 2.10), in terms of shape and size (but not of fabric, decoration or manufacture).

Figures 7.6 and 7.7

The vessels found within the excavated areas within the cemetery that cannot be associated with a particular grave are represented by coarseware dishes and bowls, including one with impressed decoration (Figure 7.6) as well as narrow-mouthed jars (Figure 7.7). Two deep basins were also found, one wheel-made and the other much coarser and handmade.

A small number of bread cone fragments (both Napatan and Meroitic) were also found, as well as the base of a beaker (3150x, 3.10.4), a beer bottle (3303x, 3.10.4) and a large flat-based spouted vessel – a cross between a feeder cup and a beer bottle (4449x, 3.11.8).

The nature of these forms suggests that they may have used for offerings and libations at a time after the burial itself, rather than being part of the original grave goods. In fact, some were found in shallow pits near the graves.

(GD3)
Grave 11

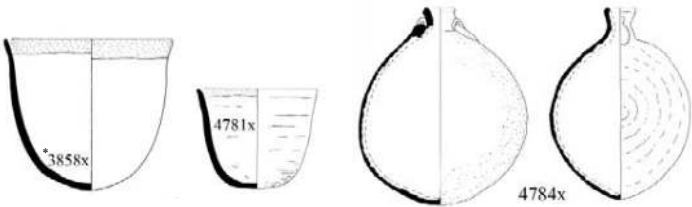

(GD3)
Grave 20

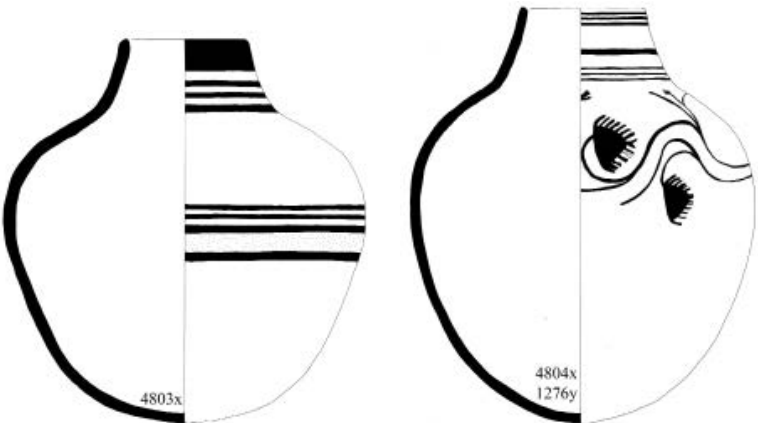

(GD3)
Grave 38

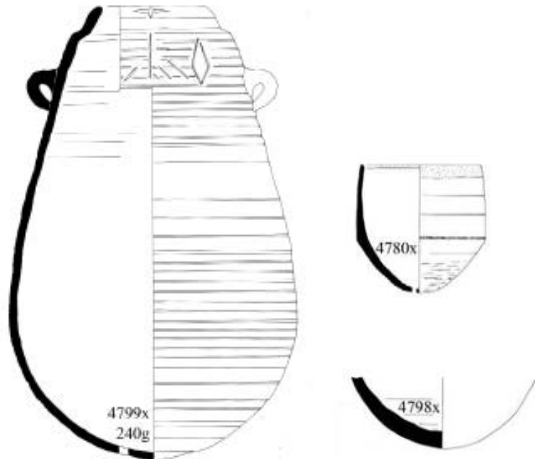

(GD3)
Grave 45

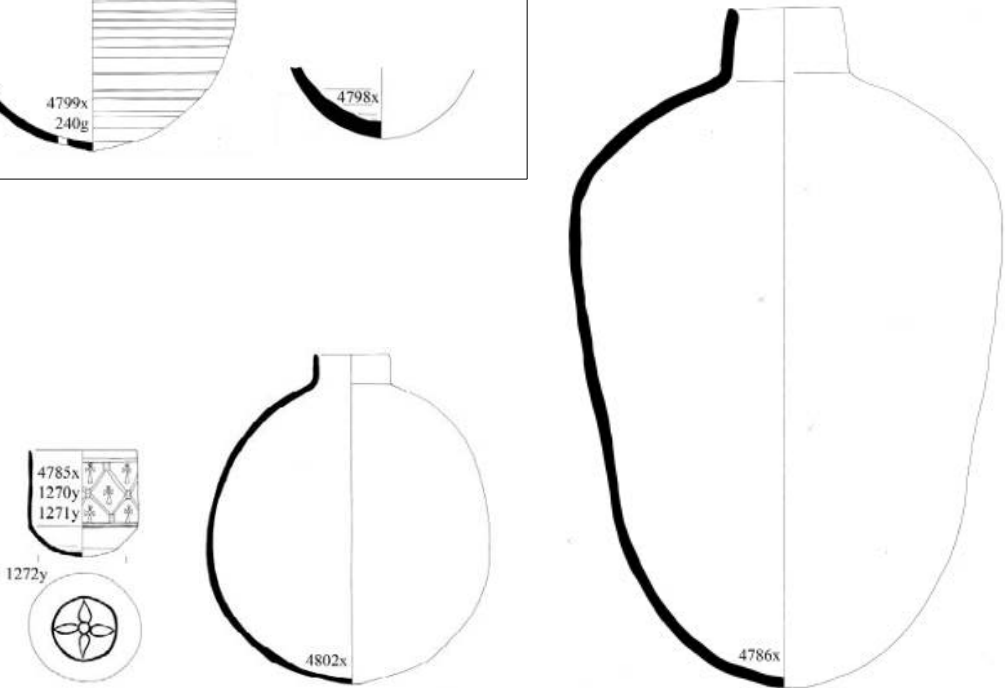
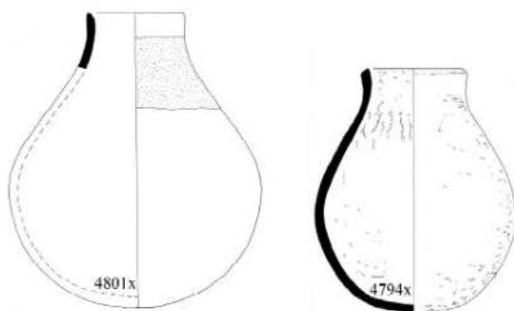
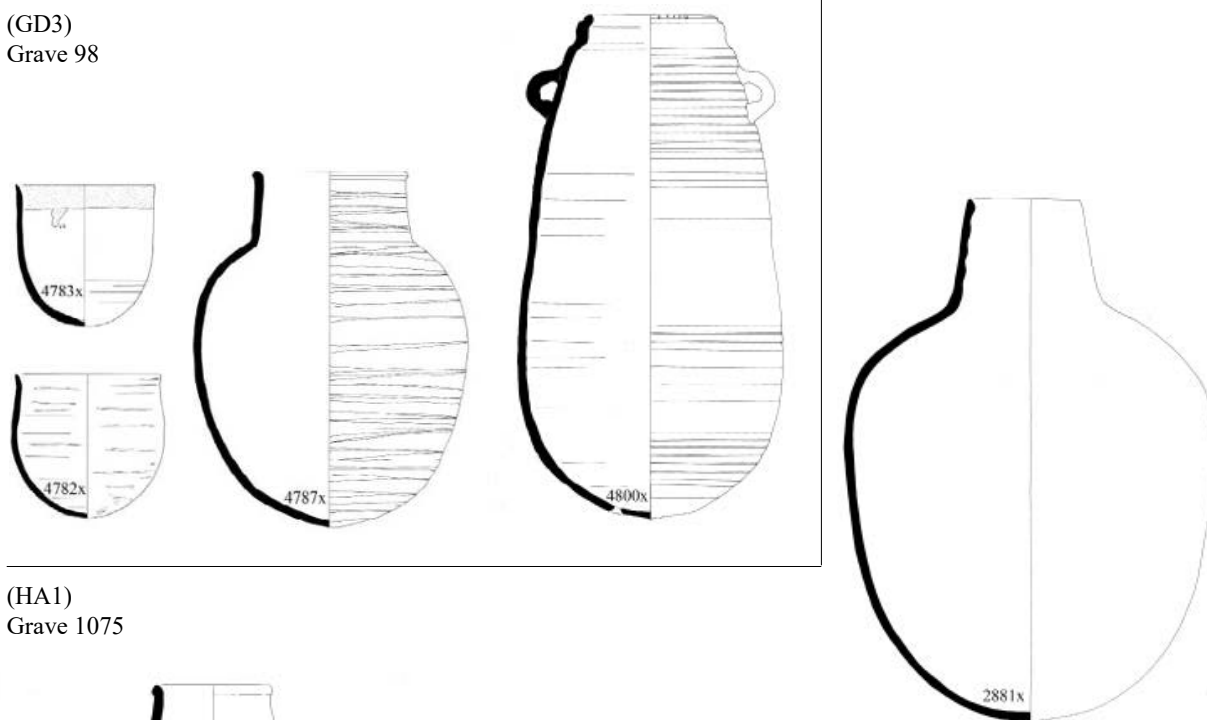

Figure 7.1. Ceramic grave goods from graves (GD3)11, 20, 38 and 45 (scale 1:6).

(GD3)
Grave 63
4794x from descendary fill



(GD3)
Grave 98



(HA1)
Grave 1075

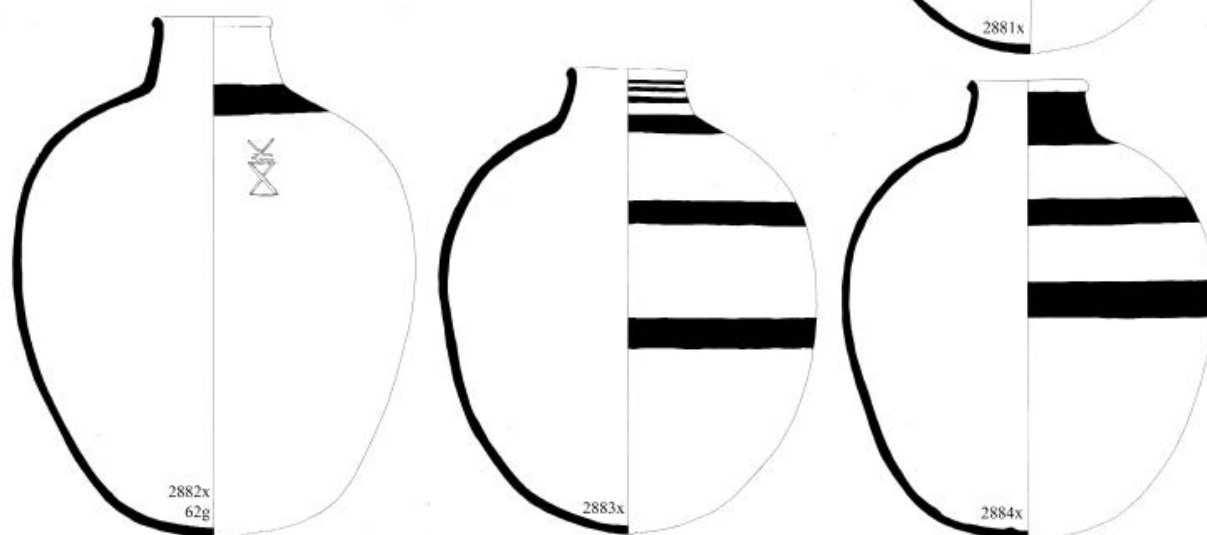

(HA1)
Grave 1084
Descendary fill



Figure 7.2. Ceramic grave goods from graves (GD3)63 and 98; (HA1)1075 and a complete feeding cup from the descendary of grave (HA1)1084 (scale 1:6).

(HA2) Grave 67 /229

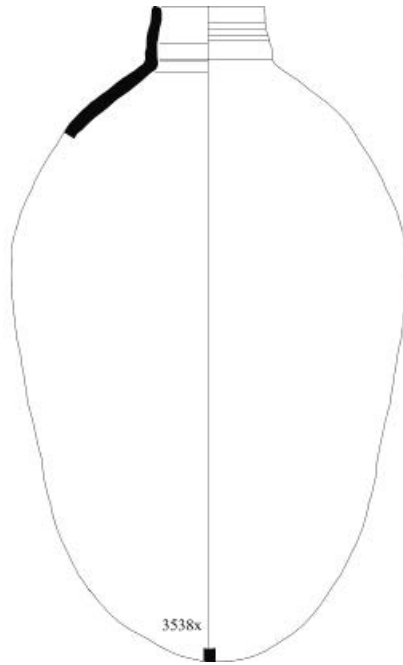

(HA2)
Grave 116



(HA2)
Grave 282



(JE3) Grave 115
Descendary and robber pit fills.

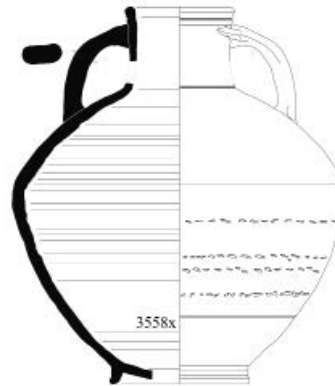

(JF2)
Grave 2

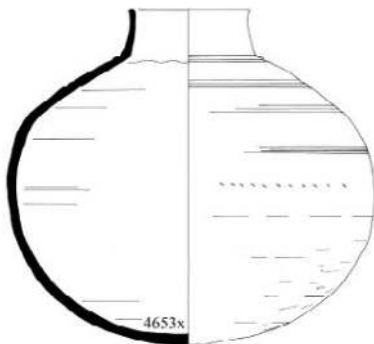

(JF2)
Grave 79

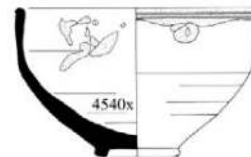
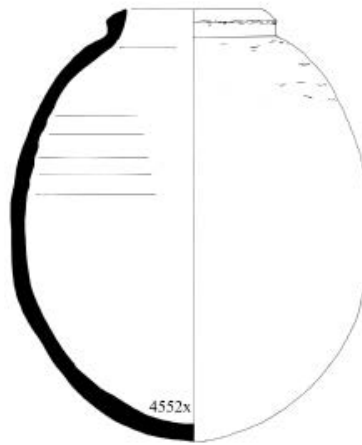
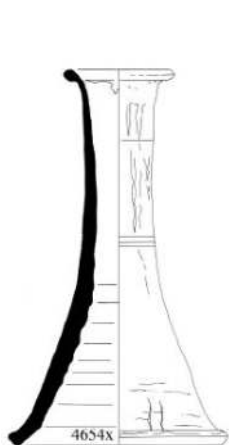
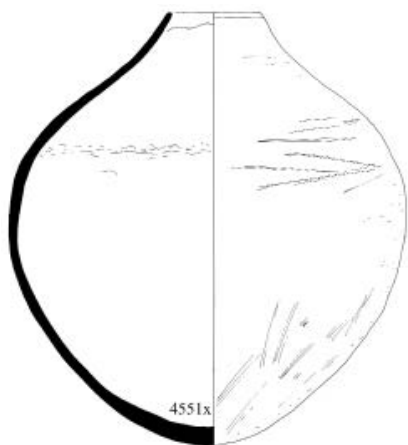
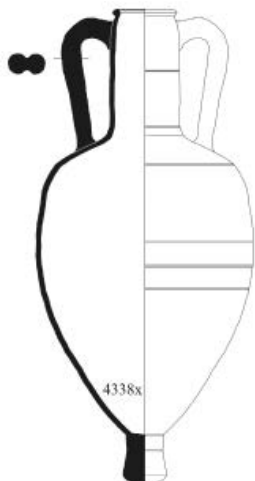

Figure 7.3. Ceramic grave goods from graves (HA2)67/229, 116, 119; (JE3)115, (JF2)2 and 79 (scale 1:6).

(JG1)
Grave 12



(JG2)
Grave 2



(JG2)
Grave 150

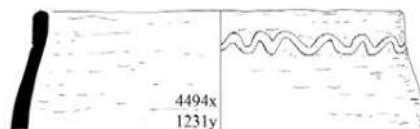

(JG2)
Grave 244



(JH3)
Grave 21

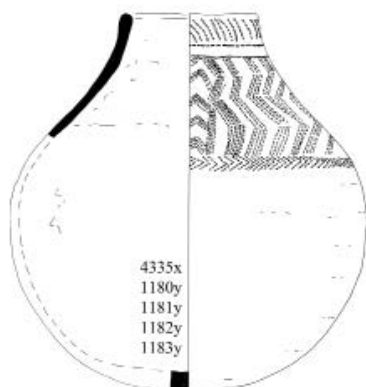

(JH3)
Grave 39

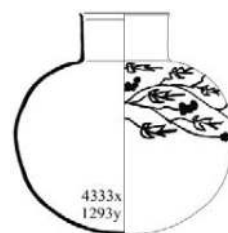
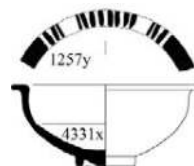
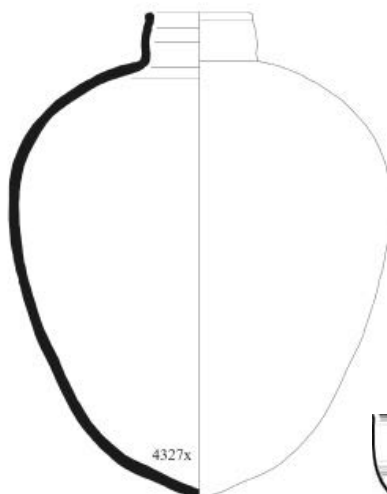
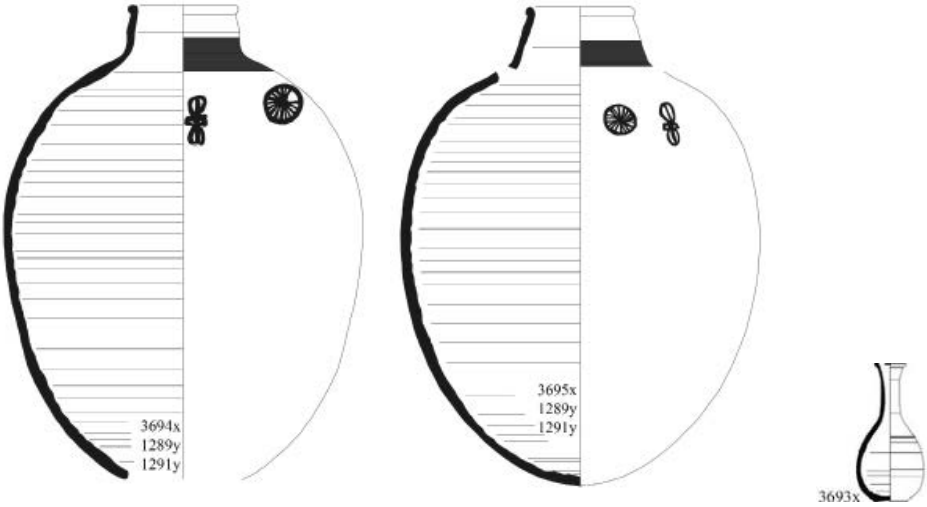
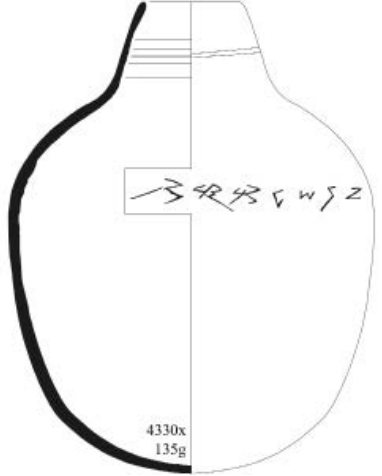
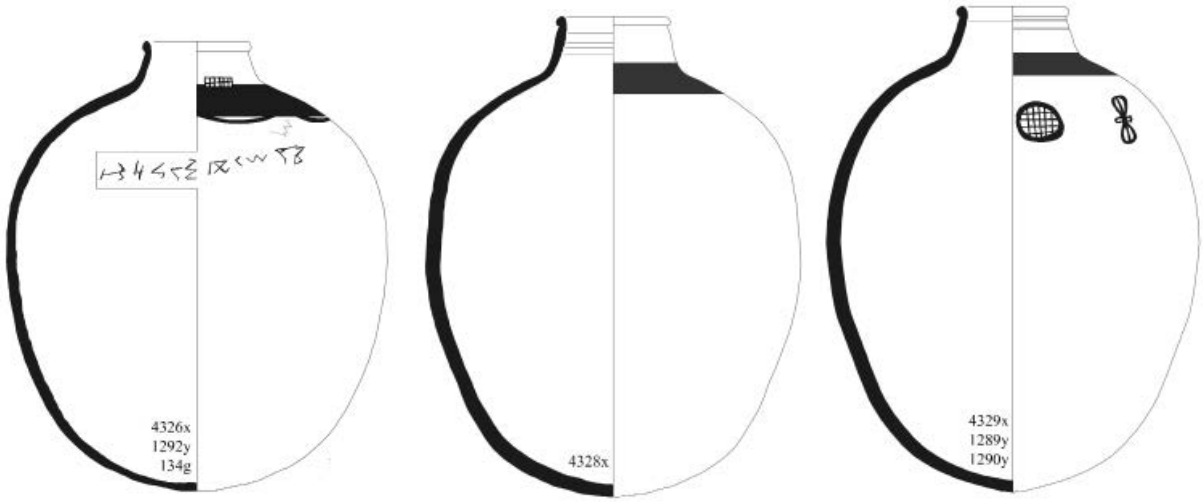

Figure 7.4. Ceramic grave goods from graves (JG1)12; (JG2)2, 150 and 244; (JH3)21 and 39 (scale 1:6).

(JH3)
Grave 43
3693x from
descendary fill



(JH3)
Grave 116



(JI4)
Grave 1

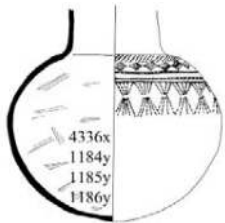

Figure 7.5. Ceramic grave goods from graves (JH3)43, 116; (JI4)1 (scale 1:6).

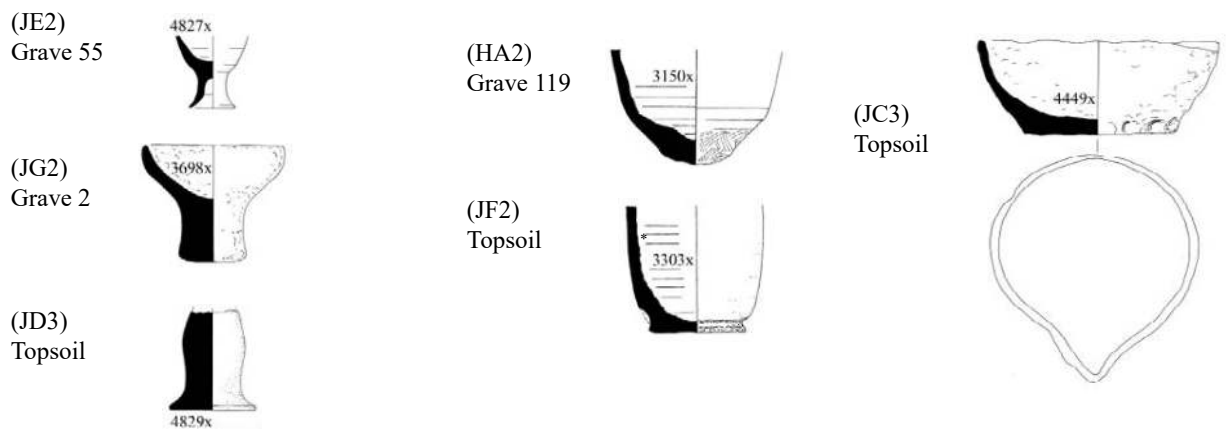
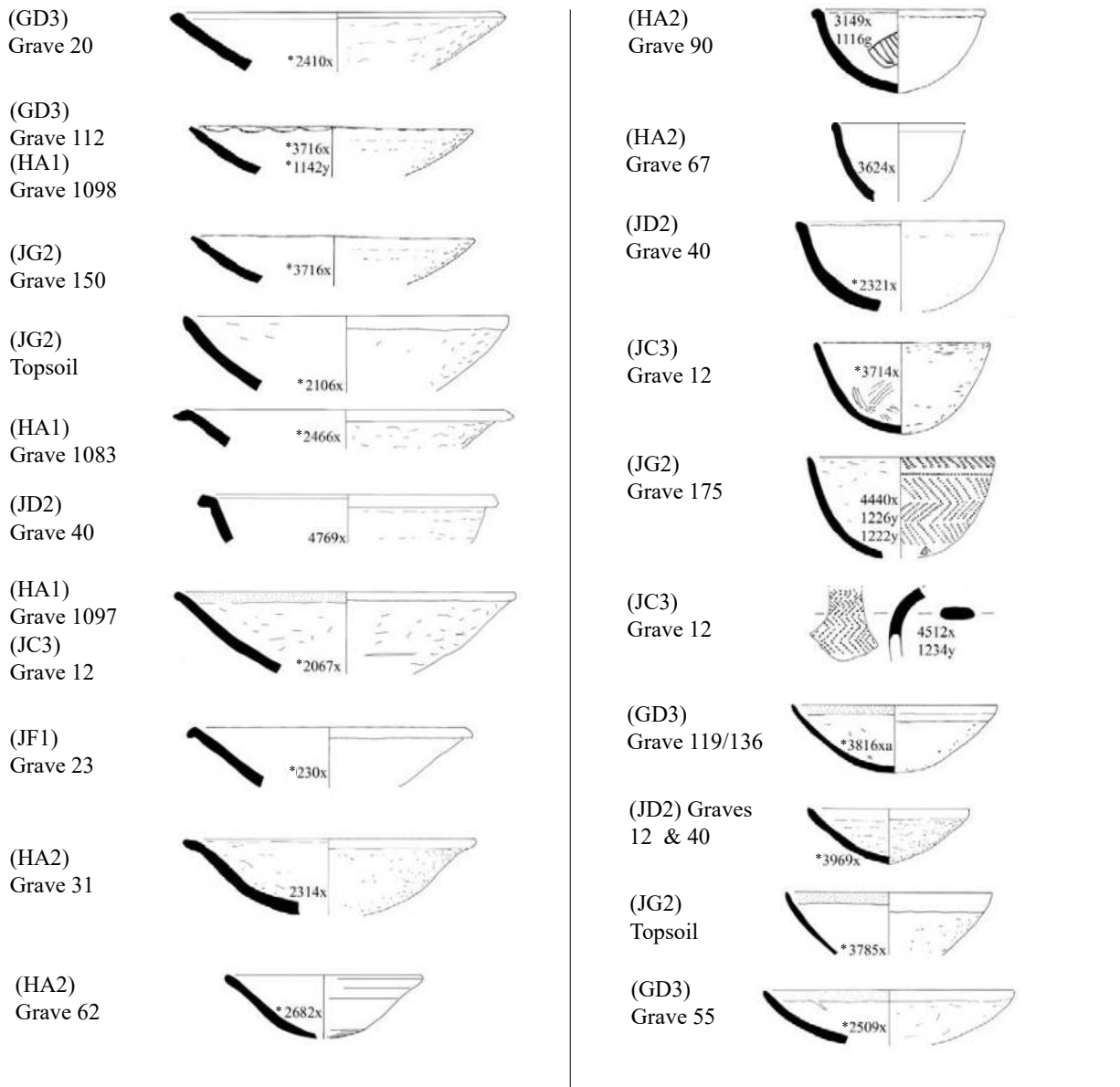
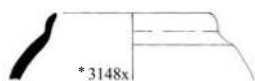

Figure 7.6. Dishes, bowls, incense burners, beakers and a spouted bowl, found in the vicinity of a grave, but that do not definitely belong to it as grave goods (scale 1:6).

(GD3) Topsoil



(HA2)
Grave 94



(JG2)
Grave 244



(HA2)
Grave 67

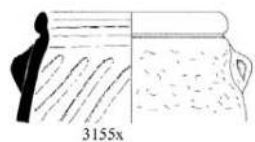

(JD2)
Grave 40

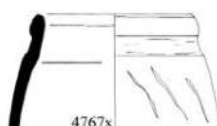

(JG2)
Grave 175

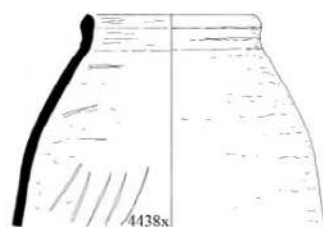

(JF2)
E rubble

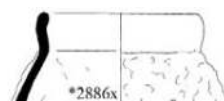

(HA2)
Grave 58

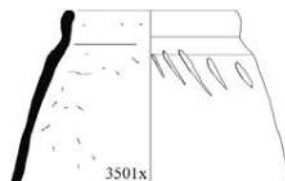

(GD3)
Grave 95



(533)

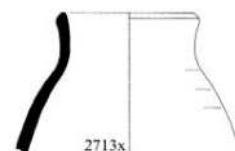

(JF1)
Grave 23

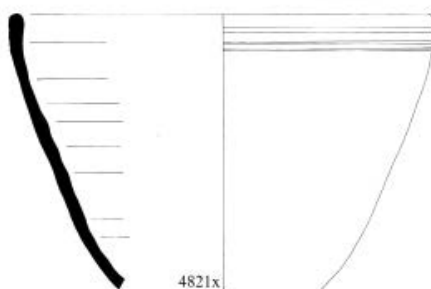

(JE2)
Grave 14

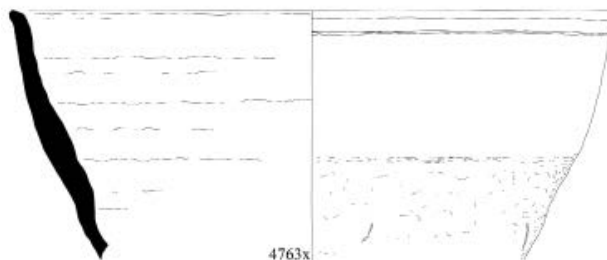

Figure 7.7. Jar and basin forms, found in the vicinity of a grave, but that do not definitely belong to it as grave goods (scale 1:6).

(GD3)
Grave 11



(GD3)
Grave 20



(GD3)
Grave 38



*Plate 7.2. Ceramic
grave goods from
graves (GD3) 11,
20, 38 and 98.*

(GD3)
Grave 98

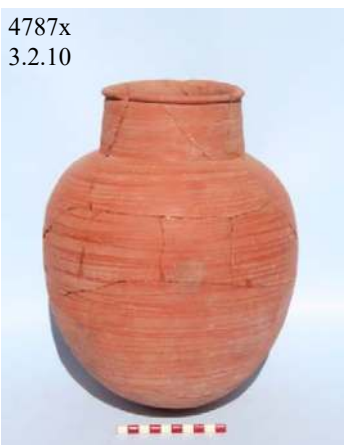

(GD3)
Grave 45



Plate 7.3. Ceramic grave goods from graves (GD3) 45 and (HA1) 1075.



(HA1)
Grave 1075

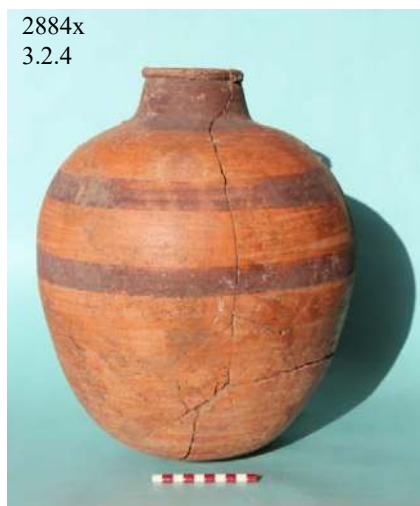

(JH3)
Grave 39



4334x 3.6.2 4332x 3.10.2 4331 3.6.12



4333x
3.2.10



(JH3)
Grave 116

4329x
3.2.5



4330x
3.2.6



4328x
3.2.5

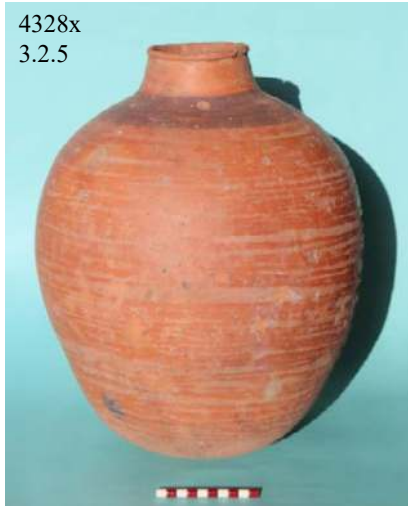

4326x
3.2.6



Plate 7.4. Ceramic grave goods from graves (JH3)39 and 116.

8. Miscellaneous Features

Distinct wares or groups with similar characteristics

820 and 822

Vessels with a slip. The most common colour is red, followed by white, yellow/cream and black, occasionally fired purple and grey. Orange becomes popular in the Meroitic. Slips were applied either on the interior exclusively or on the exterior, but also on both surfaces. A thin wash was applied first and is generally visible on the side that is not slipped, just under the rim. On the interior of cooking pots it presumably was applied to provide a non-stick quality, whereas on the exterior it was perhaps mainly for decorative purposes; in both instances it would have limited the seepage of liquids through the otherwise porous walls of the vessels.

The slipped RVE make up 7.6% of the total and 5% of the total number of sherds. However, as discussed elsewhere, the pottery from Area B and parts of Area A does not include body sherd counts, so it is would be more accurate to look at the rim percentage, were it not for the fact that there were plenty of slipped body sherds dissociated from a form that thus are not included. Still, the RVE % serves as a guideline.

TABLE 8.1. SLIPPED VESSELS FOUND ACROSS SITES Q3 AND R18.

Provenance	Sherds	Weight	RVE %	% of rim total
Total	10409	544929	28194	7.6 ^a
(A)	1886	119715	7387	5.3
(B)	859	72314	6972	20.6
(C)	2176	113172	2882	17
Building F1	474	17955	3187	2.7
Kilns	738	32561	1110	3.7
(FZ1)	19	195	10	0.5
(FZ2)	7	85	6	0.5
(TG5)	1931	47944	2668	19.1
(ZH)	157	15223	907	39.4
Site R18	1156	125755	3064	39.5

^a The percentage of slipped vessels among the total RVE count of both the town site and the cemetery.

Table 8.1 shows that, while slipped vessels are not confined to the Meroitic period, they become more common place. In the Napatan period the most characteristic vessels with a slip (red) are the fine narrow beakers (see 3.10.3). This generalisation is still valid if we take into account that Area T, the kilns and the cemetery span both the earlier and later Kushite period.

RBR

Rims that were decorated with a red band are ubiquitous in the Napatan period (and New Kingdom, but no forms

of this earlier period have been recognised at Kawa) but quickly die out in the Meroitic. In Table 8.2 the comparative proportions are based on the total rim percentage within an area versus the percentage of rims with red bands (RBR, RBR, etc). As can be seen in the table, the earlier the assumed date of the area, the higher the number of vessels with RBR. This comparison is all the more valid because cups and cooking pots are prevalent in all areas, regardless of their function – whereas for other forms it could be argued that they are absent because they would simply not have been used in a given context.

TABLE 8.2. PRESENCE OF RBR AND VARIANTS ACROSS THE SITE, ARRANGED IN ASCENDING ORDER ACCORDING TO RVE PERCENTAGE.

Provenance	RBR sherds	Weight	RVE %	% of rim total
(Z)	-	-	-	-
(C)	6	235	43	0.2
Site R18	25	1430	430	5.3
(B)	81	4070	762	2.1
(FZ2)	144	2017	965	76.5
(TG5)	115	14308	1308	6
(FZ1)	267	2709	1672	84
(FQ) etc.	3428	38021	18528	61.8
(A)	6909	126773	34805	25
Building F1	13917	224447	93446	79.2
Site Q3	25598	429727	151529	42
Sites Q3 + R18	25623	431157	151959	41.2

Ware 910

910 (smoothed rim and rough body, see Section 3.8 and Table 8.3) is a common form of coarseware. Unlike RBR,

TABLE 8.3. PRESENCE OF 910 FOUND ACROSS SITES Q3 AND R18.

Provenance	910 sherds	Weight	RVE %	% of rim total
(FZ2)	13	210	68	6.1
Site R18	17	1145	96	1.1
(FZ1)	27	370	140	7
(Z)	27	3005	265	11.5
(B)	41	2925	313	0.9
(TG5)	120	3065	653	4.7
(C)	225	14588	1753	10
(FQ) etc.	1746	26990	5067	17
Building F1	3955	85291	27535	23.3
(A)	8807	187935	12168	8.7
Site Q3	14962	324659	47976	13.3
Site Q3 + R18	14979	325804	48072	13

the results are not as easy to interpret. Ware 910 occurs throughout Q3 and R18; there is an absolute minimum of 481 vessels, 14,979 sherds weighing 325 kg. Not unexpectedly there is only a small amount present in the cemetery; interestingly there is much less in Area B than C, although these areas share hundreds of pottery types, particularly coarseware forms. Building F1 has the highest score of both RBR and 910, whereas FZ1 and FZ2 have a much smaller proportion of 910 pots; however, as in these two areas we are dealing with a much smaller total of excavated sherds, the numbers may be off for this reason. For example, (FZ2) is a street and the function of Building F4 in (FZ1) is unclear. Alternatively, it is the function of the areas and thus the pottery present, that has affected the score.

CRR

Crackled rims – the rim of a coarseware handmade vessel having been left to dry without any attempt being made to smooth it. The fabric and otherwise aspect of such bowls is similar to 910 but they have a more restricted range of forms, simple bowls and dishes but not jars or *doka*. Enough instances occur (626 sherds weighing 23,954gm, RVE 4,879%) across the site that this must have been a deliberately achieved effect. Nevertheless, they only make up a small percentage of the pottery found, and judging by the areas where they are most common, CRR is most likely an early Napatan production.

TABLE 8.4. PRESENCE OF CRR (CRACKLED RIMS) ACROSS SITE Q3. NONE WERE FOUND IN SITE R18.

Provenance	CRR sherds	Weight	RVE %	% of rim total
(FZ1)	-	-	-	0
(Z)	-	-	-	0
Site R18	-	-	-	0
(FZ2)	1	20	8	0.63
(C)	2	25	10	0.06
(B)	2	50	14	0.04
(T)	10	201	46	0.33
(F) kilns	93	2422	657	2.19
Building F1	232	11962	1822	1.54
(A)	286	9274	2329	1.67

Wasters and unfired vessels – a clue to pottery production at Kawa?

A total of 22 sherds were recorded as wasters, being over-fired and deformed. These are all wheel-made except for one, and recorded as Fabrics 9, 66, 67, 69, 70, 94 and 25 or 92 (or the fabric type was impossible to determine). However, as four of these sherds belong to Napatan amphorae and all were found in domestic contexts (one even has a mending hole) it is likely that the vessels were still usable despite having been poorly fired and/or dented or otherwise deformed before firing, and thus the evidence is not sufficient to suggest a local production. On the surface, in the vicinity of the gateway into the temenos (Area

TG5) there were, however, a number of over-fired bread cones, and so at least these are more than likely to have been manufactured at Kawa, as one would expect. Vast numbers of bread cone fragments were dumped over the *temenos* wall a little to the north of the gateway. Waster forms found were: 2003x (3.1.4), 2028x (3.12.4), 2042x (3.12.4), amphora rim and handles; 2050x (3.7.15), 2057x (3.3.1), 2144x (3.3.1), 2191x (3.3.1), 2225x (3.7.18), 2332x (3.3.2), 2573x (3.10.4) and 3120x (3.3.1), closed jars or coarsewares.

A more secure indication of pottery production at Kawa are the unfired vessels (or in some cases only partly fired), surely not brought from anywhere but the town itself. In total 47 instances were recorded, from all areas of Q3 except for Z. Not surprisingly, these mostly consist of simple utilitarian forms such as bread cones,¹ bread ovens or storage bins,² bread platters,³ *doka*,⁴ a bin lid (?),⁵ a lug handle (?),⁶ and rough dishes and bowls,⁷ but more interestingly also rim sherds of two wheel made bowls, 2031x from (AB6)10 and 2026x from (BF2)11, a beaker (2695x from (AB5)233) and a partially fired bowl of type 2770x (3.6.7) from (AB5)41 (Plate 8.1). Another interesting point to emerge from the



Plate 8.1. 2770x (AB5)41, a partly fired bowl.

synthesis of the unfired fragments is that the vessels were not made up for firing next to a kiln (as we have not found one) but brought somewhere else for the firing, whether in a kiln or in an open area.

Repairs – mending holes

A number of vessels have been repaired following break-

¹ (AB4)11 2482x; (AB5)40 2693x; (AB5)207 2655x; (AB5)40 2655x; (AC5)62 body sherd; (AC5)57 2655x; (AD5)149 2311x; (CF4)59 body sherd; (CE4)47 2633x.

² (AB5)59 2256x; (AD5)112, (AD5)178, (FQ4)55, (FP6)143 body sherds.

³ (AB4)23 2418x; (BF1)53 2297x; (FO6)129 2075x; (FO6)91 2060x; (FO6)92 2060x; (TG5)44 2648x.

⁴ (AC5) 8 3262x; (AD5)69 3264x; (AC5)131, (FP6)54 body sherds

⁵ (BE2)100 2688x.

⁶ (BE1)80 4736x.

⁷ (AB4)67? 3860x; (BD4)17 body sherd; (BE3)10 4727x; (BE3)18 4726x; (BE4)59 body sherd; (BF3)9 2893x; (CF4)88 3853x; (FQ3)31 +4834x; (FO6)47 2675x; (FO6)62 2509x; (FP6)9 3856x; (FP7)19 2590x; (FP6)128 3716x; (FP6)128 body sherd; (FP7)14 3449x; (TG5)29 4732x.

age in antiquity in order to extend the life of the pot (208 sherds/ vessels, total weight 16.918kg). Generally this was done to storage containers, both local and imported, but also even to a few bowl and basin forms.⁸ In the case of one clearly much-beloved Napatan amphora no less than 32 repair holes had been drilled from just below the shoulder down the wall vertically as far as the base (4679x, 3.1.5). No trace of the material used to bind the two edges was found, but it would presumably have consisted of twine, sinew or leather strips. The holes were drilled from the outside (for obvious practical reasons), and care had to be taken to avoid the vessel wall splintering or shearing off; the thinner the wall, the easier the task.

Other holes, pre- and post-firing

Another feature of many vessels is the holes made pre-firing: near the rim for suspension, or in the base for drainage (?). The base holes probably had a variety of functions, and were made (often but not always) before firing. The straightforward suspension holes were normally made in pairs, before firing (Plate 8.2). It remains unclear whether there would have been a second pair on the opposite side of the pot (putting less strain on the wall of the vessel, but not proven by the material from Kawa).⁹ Other vessels have



Plate 8.2. Hanging pot with pre-firing holes and rope wear marks (3.4.6).

holes (not repair holes) that have been made after firing, also on the upper half of the body, and in this case it is not clear if they are improvised suspension holes or if they were intended as air holes, if for example the vessel was used

⁸ Forms with repair holes (figure references all within Chapter 3): 220x (7.16), 1013x (7.20), 2000x (3.05, 7.15 or 7.9), 2002x (6.4), 2004x (1.3), 2007x (4.4), 2022x (6.2, 7.9, 7.15 or 8.5), 2022xa (8.5), 2022xd (7.9), 2024x (6.8), 2025xc (7.9), 2026x (6.9), 2027x (3.1), 2039x (8.2), 2044x (3.7), 2050x (7.8 or 7.15), 2061x (7.18), 2064x (2.12), 2066x (5.11), 2088x (7.23), 2116x (8.1), 2128x (6.11), 2129x (3.4), 2144x (3.1), 2164x (4.2), 2169x (7.23), 2183x (1.10), 2214x (8.5), 2235x (6.2), 2254x (3.4), 2256x (7.16), 2257x (8.11), 2264x (7.18), 2266x (8.13), 2291x (7.21), 2293x (4.3 or 6.11), 2302x (7.17), 2304x (7.15), 2310x (7.8), 2329x (7.15), 2337x (10.2), 2347x (9.13), 2350x (4.8), 2405x (3.10), 2415x (1.3), 2427x (5.11), 2434x (4.4), 2439x (7.22), 2469x (6.7), 2488x (3.2), 2505x (1.10), 2520x (4.3), 2548x (5.6), 2561x (12.2), 2576x (4.3), 2578x (8.1), 2617x (6.7), 2691x (1.10), 2743x (3.2), 2744x (4.1), 2768x (7.8), 2816x (1.3), 2826x (1.6), 2893x (7.10), 3003x (7.15), 3152x (6.3), 3166x (4.7), 3179x (3.2), 3664x (2.12), 3679x (7.8), 3696x (6.3), 3862x (7.4), 4459x (2.7), 4529x (3.2), 4530x (8.9), 4541x (7.11), 4547x (8.9), 4679x (1.5), 4681x (1.7), 4684x (2.2), 4740x (1.8).

⁹ Nor is it clear from the jar displayed in the museum at Kerma, missing the part just opposite the pair of hanging holes.

to keep poultry safe (as our landlord at Kawa did with his chickens at night, keeping them in a *zir* with holes drilled in the walls and a secured lid) – possibly an impromptu version of pigeon pots (see 3.4.6), of which there are only a few instances at Kawa. Some of the coarseware pots have between one and three holes (3.8.3); again, for use as pigeon pots or as some kind of crude colander? In one instance, it is even possible that the vessel and hole were intended for use as a plant pot (base 3387x [3.12.2]).

A more specific purpose of some of the perforated vessels might have been for use in a still, to produce either alcohol or perfume (Belgiorno 2020, especially figs 3-7). Following the making of replicas of vessels found at the Bronze Age site of Tepe Gawra, near Mosul in northern Iraq, it has been demonstrated that these were components of a distillery. A flanged lower vessel would contain the liquid to be distilled, with a upturned smaller vessel with a hole in its base serving as lid. Forms 3244x, 3307x (3.8.3), 2819x and 3471x (3.7.1) would fit such an arrangement. However, the near total absence of colander sherds at Kawa, an integral part of the Tepe Gawra apparatus, poses a problem in accepting this theory. Nevertheless, it should be investigated further, in view of the otherwise unclear purpose of the crude pots manufactured with perforated bases.

The neat holes drilled near the bases of the Napatan amphorae (and in some storage jars, e.g. 2719xb and +2792x [3.4.11]) are a different matter, and are discussed further in Section 6.

Vessels found *in situ*

There are various instances of vessels set into the floor surfaces of rooms in Areas A and C, and amphora 4337x (with its base missing) in Building F1, pots (generally cooking pots) installed near hearths; the most striking example of pots found *in situ* is in Area (FQ4), where 10 vessels were found set into surface 113, outside Building F8, with an additional three, including a nearly complete RBRIE bowl (3973x, 3.7.5), within one of them, a large sub-rectangular basin (4639x, 3.9.8); see also Welsby 2023e, pls 7.3-7.6. The vessels set around the basin were poorly fired cooking pots, one with 8y thickening on its base, and all except for two (2022xa and 2025xc) had lost their rims, most probably subsequent to the original usage of the area. All were made of Nile silt fabric, and, not counting the basin, the largest measured 37cm in diameter; the surviving heights varied from 16cm to 19cm. It is unclear how the ‘installation’ functioned, but the collection of vessels brings to mind some form of *thermopolium*.

Reused vessels

A handmade jar with a flange rim (3385x, 3.8.1) was found upside down in Area A, Building A2, Room III, with the centre of the base missing and a part of the rim cut away, making up the core of a cooking oven, the missing rim section part of the flue (Welsby 2023c, pl. 3.46). Another jar, (2029x, 3.5.2, from (BF2)49, Building B1, Room III) was found with the rim crudely chipped all around the perimeter – intentionally done, but for what reason is unclear, unless it

was to make it fit into a location narrower than the original rim diameter. The ring-footed base of a wheel made jar, (4592x, 3.12.3 (CF4)109) had the centre of the base missing and the broken edge smoothed, as if for use as a ‘pigeon pot’, or, according to the original explanation, as an oven.

A number of the RBRIE cups or beakers have been found partially broken and with traces of burning by the remaining part of the rim (see Plate 6.2). As already mentioned above, the so-called lamps do however not show any sign of oil staining from the fuel that would have been used. Their reuse as lamps is therefore uncertain, especially as no custom-made lamp forms have been found. It would seem unlikely that, if there was a demand for lamps (and fuel for them), the cheapest vessels available (in the Napatan period) would have been adapted for this purpose, rather than the required form made outright by a potter. What does seem clear is that they were reused in their broken state, perhaps again as bowls or as scoops.

Weight

The intent throughout the recording in the field was to weigh all the pottery (with some slip-ups). It is therefore useful to provide the full weights of some the pottery types, to serve as a guideline for estimating the percentage of a pot that is found as body sherds (all with the same surface treatment and fabric), or indeed if more than one pot is represented, especially if the rim or other diagnostic parts are missing (Table 8.5). The weights of some of the complete or nearly complete Napatan amphorae have already been presented in Chapter 6; here follows a summary of the weights of some common types which were found complete, (whether whole or subsequently reconstructed) or very nearly complete.

Volume

Regardless of what the contents were, how much did the vessels contain? The capacity of the storage and especially transport vessels is of interest, and the size of drinking, eating and cooking vessels contributes clues as to how food was served, and in what quantities. This subject will not be gone into in any detail here, apart from contributing some volumes for the average sized cup, beaker and dish, as well as for some of the transport vessels.

As was already mentioned above in 3.2.1, the Levantine amphorae have been calculated to have contained around 14 litres. Looking at the superimposed images of a Meroitic beer jar (capacity approximately also *c.* 14 litres) over a Napatan amphora (Figure 8.1), it looks as if the latter would contain more or less the same, while the larger size of Napatan amphora would have a volume capacity some two times that. However, the weight of this latter type, especially considering its thin walls, would be considerable if the contents were grain or liquids. Despite the strengthening effect of the ribbing, the vessel would have been far too fragile and thus almost impossible to transport. Possibly it was used for shipping something less dense – cotton? The more practical 14 litres compare well with the average capacity of Greek and Roman period amphorae (see the Southampton

TABLE 8.5. AVERAGE WEIGHTS OF A SELECTION OF FORMS.

Figure	Form	Type	Weight (gm)
3.1.4	Napatan amphora, silt	4800	3,530
3.1.5	Napatan amphora, marl	4679	2,460
3.1.7	Large Napatan amphora	4337	8,125+
3.2.1	Campanian amphora	4338	1,373
3.2.2	Beaded jar	4787	2,320
3.2.4	Beer jar	2883	4,450
3.2.4	Beer jar	2884	3,775
3.2.9	Piriform jar	4786	10,465
3.2.11	Pilgrim flask	4784	350
3.4.11	Storage jar	2792	7,600
3.7.1	HM jar	4801	1,200
3.6.1	820EBL jar	4335	3,475
3.6.6	Cup	2597	400
3.6.12	Bowl with ledge rim	4540	1,000
3.7.1	HM jar	4801	1,200
3.7.3	Bowl	4655	1,440
3.7.5	RBRIE bowl	4630	430
3.7.6	RBRIE cup	3858	479
3.7.10	Cooking pot	2767	2,600
3.7.15	Bowl	3003	1,100
3.9.6	Bread platter	2603	1,725
3.10.3	Beaker	2948	225
3.10.6	Dish	2109	360
3.10.7	Dish	4175	350
3.11.7	Pot stand	4661	4,500

Amphora Database, https://archaeologydataservice.ac.uk/archives/view/amphora_ahrb_2005).

The capacity of Napatan dishes ranged between 300ml and 500ml, while a RBRIE beaker could accommodate *c.* 550ml (almost a pint, in fact), and a Meroitic fine-ware cup like 4785x about 300ml (this calculated based on the vessels not being filled to the brim, but leaving a reasonable 1.5-2cm from the top of the rim). The dishes would thus contain enough for a reasonable meal for one person, or they may have been used for a communal meal, such as today in Sudan and elsewhere. The containers most likely intended for drinking approximate the size of glasses and mugs in the present day.

A jug with a single handle, admittedly a rare form at Kawa, could contain *c.* 1 litre, and the round-based beakers (3.10.1) had a capacity of no more than 1.8 litres – perhaps the contents were meant to be shared, and the beaker passed around, unless it was intended for pouring libations.

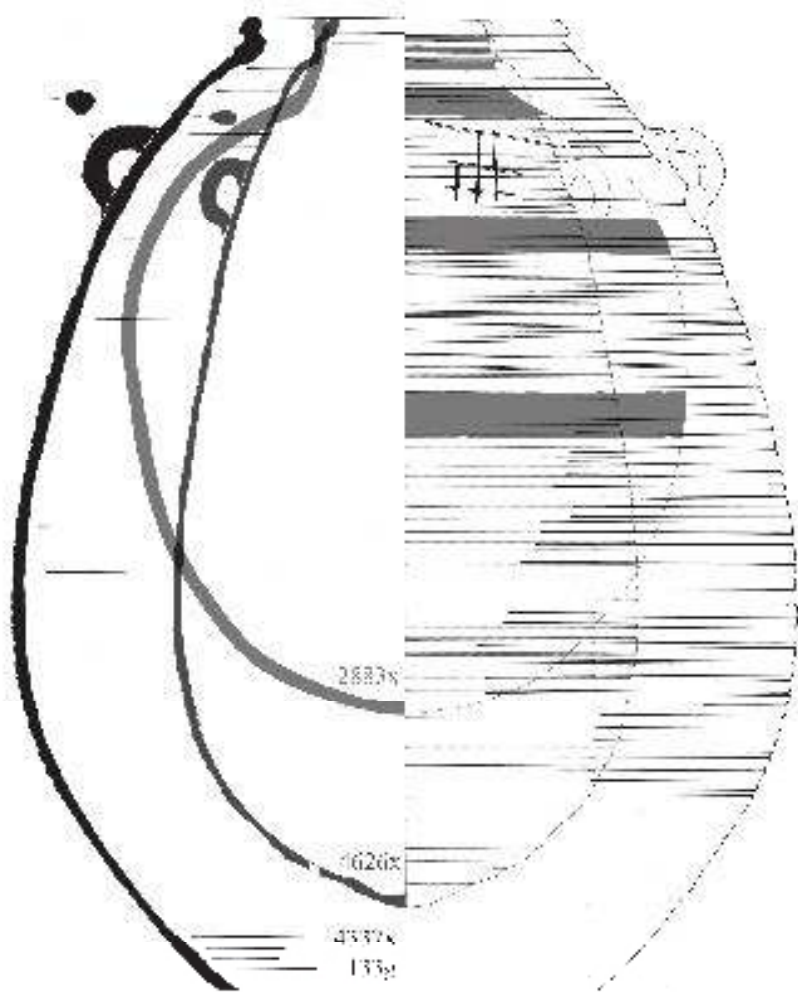

4337x 3.1.7 c. 35lt
4626x 3.1.5 c. 14lt
2883x 3.2.4 c. 14tl

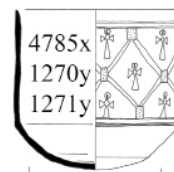

3.6.2
c. 300ml

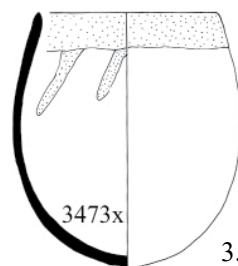

3.7.4
c. 550ml

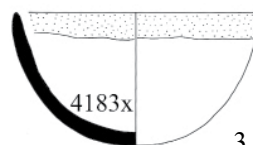

3.7.7
c. 300ml

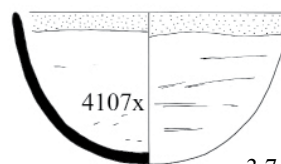

3.7.7
c. 500ml

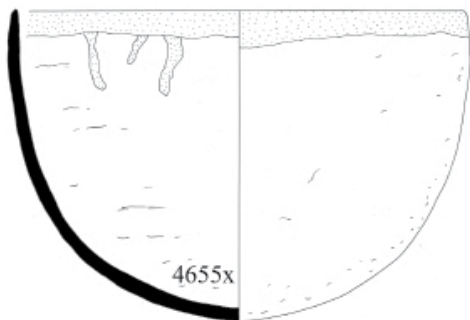

3.7.3 c. 3000ml

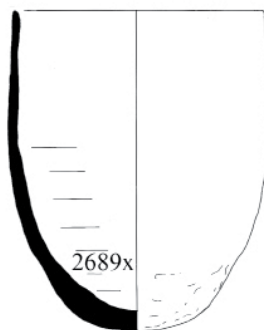

3.10.1 c. 1800ml



3.2.11 c. 1000ml

Figure 8.1. Volumes. All vessels to scale 1:4.

9. Discussion of the chronology and character of the assemblages by area

The chronology of the areas excavated at Kawa is reasonably straightforward. The very earliest deposits were probably those partially excavated in the lowest levels in Area A. Other very early deposits may be those reached in the sondage dug deep below the construction level of Building B14 and those beneath the gateway into the *temenos*.

The oldest rectilinear mud-brick building excavated appears to be Building F1, consistently dating to the early 7th and 6th centuries BC. Building F4 (FZ1), and (FZ2), a street, appear to be contemporary with Building F1. Next chronologically comes Building A1, with its altar to Taharqo, probably contemporary with the adjacent Building A2, followed by the mud-brick buildings in Areas B, C and Z (areas of housing). The differences in the assemblages of Areas B and C are interesting in that they are both domestic in nature, but although they share a large number of forms there are others that are different, suggesting that they are not contemporary, or had a different status.

The kilns (in grid squares FQ, FS, FR and FT) disturbed earlier Napatan (domestic?) structures, Building F8 and possibly Buildings F9, F12 and F13. Meanwhile, grid square (TG5) is multi-period, with contexts pre-dating the gate (i.e. pre-7th century BC) to its last vestiges in the Meroitic period.

Relating the chronology between areas is complicated because of the different uses the areas had been put to, resulting in different ranges of pottery forms perhaps due as much to functional as chronological factors. For example, to what extent are the more fanciful forms, such as the oval basins with appliqué faunal rim decoration, related to the function (ritual?) of the building in which they were found or to a particular period? With the range of bell-shaped, round-based jars – is it the status or activities in the building they were found in that explains their presence, or were they the fashion at a particular period, in this case the later Napatan? Other forms, such as the small ‘offering dishes’ (3.10.6–3.10.7) occur in all Kushite periods, but especially in the Napatan between the 7th through 4th centuries BC. Their greatest concentration at Kawa is in Building A2, also dating to the Napatan era. In this instance they are perhaps more indicative of the use the room or building was put to rather than date, although it could be argued that their use could also be purely functional rather than necessarily tied to ritual ceremonies. Whatever the reason, they are plentiful in Building A2 and in the adjoining midden immediately to its north. As for the Napatan amphorae (especially 3.1.2–3.1.9) and Meroitic beer jars (3.2.4–3.2.8), their presence in an area is indicative of the activities pursued there as well as being date-related. In the case of single sherds of a distinctive or datable character, these may be explained as residual or intrusive and do not necessarily change the overall date of a floor, room or building; this is a normal occurrence. This publication will hopefully contribute to understanding the norm of the assemblages in any particular period within buildings of a particular type.

Returning to the issue of to what extent sherds of vessels that are chronological indicators may be residual or intrusive: for example, the absence of the clearest indicators of Meroitic date, eggshell ware and slipped beer jars. Is this indicative of the function and status of a layer in an area at the time it was deposited or a product of its date? Being high-status wares, they are likely to be absent from humbler dwellings. Hence the need to know the characteristics (apart from the distinctive forms and decoration, also the fabric and surface finish) of coarsewares of the period.

A comparison of the types of vessel present in Areas B and C shows that both have very similar cooking pots, albeit in forms that are not particularly distinctive, but also very small bowls, dishes, jars with restricted openings, and some large bowls or open-mouthed jars with a crude lid seating. The lid-seating in particular is characteristic of these two areas. What is absent in Area C but present in Area B are imports and more elaborate forms.

An interesting factor is the reduced presence of RBR (red band by rim) decoration on coarseware bowls and cooking pots in Area C and its complete absence in Area Z, both areas that appear to be later in date than the others excavated in the town, apart from the later levels in the *temenos* gateway, which had a very different function.

Napatan amphorae (see Chapter 1) occur in all areas, but are only represented by one rim in Area Z, and relatively few instances in Area C.

Indicators of a Napatan date include surface finish and simple decorative features, especially RBR on cups or bowls and cooking pots or general coarsewares with 910 (smooth rim and rough exterior) and the presence of Fabrics 23, 102, 103 and 113, most commonly found in Napatan amphorae imported from Egypt. Fabric 87 belongs exclusively to imported Levantine amphorae; although far fewer of these vessels have been found than Napatan amphorae from Egypt (or local copies of the form). It is worth noting that none of the Levantine containers carry graffiti, and neither do the examples found at Hillat el-Arab (Vincentelli 2006).

Indicators of a later, Meroitic, date include Fabric 26, the fine kaoline fabric, and coarsewares made from quartz-rich fabrics, such as Fabric 58. Note that the Neolithic Fabric 5 could be mistaken for the Meroitic variant. Fabric 132 is an indicator of Meroitic-period pottery.

In terms of form, ‘beer jars’ with a beaded rim are a characteristic of the last two centuries BC; cooking pots with lid seating, such as seen in sections 3.3.10 and in 3.8.9 are almost exclusively of a post-Napatan date, and are particularly common in Area C.

Cooking pots do not change greatly over the Kushite period: a slight increase in inverted rims, while the thickening of the base, 8y and variants thereof, is prevalent throughout the town except in Area C, where it is proportionally rare, occurring in conjunction with rim decoration 1017y (see for example 4754x, [3.7.12]). Note however that ware 910 seems to disappear in the later contexts (early Meroitic and

TABLE 9.1. THE PROPORTION OF WHEEL-MADE AND HANDMADE POTTERY FOUND ACROSS SITES Q3 AND R18.^A

Wheel-made includes the use of the slow wheel.

Handmade covers all manufacturing techniques by hand, coil, mould, etc.

UNK = unknown, where it was impossible to determine manufacture because of surface abrasion, the surface being hidden by a slip, or where body sherds were not sorted thoroughly before counting and weighing.

Provenience	Sherds	WM %	RVE WM	HM%	RVE HM	UNK ^B	Weight	WM %	HM%	UNK
(A)	47,320	45.65	89909	54.18	49257	0.17	1,642,435	60.50	37.07	2.43
(B) ^C	4,622	52.38	17969	39.61	15894	8.01	398,410	43.42	50.29	6.29
(C)	29,182	49.70	3768	49.95	13156	0.35	907,279	44.04	55.40	0.56
(F) Kilns	31,181	22.40	4325	77.01	25650	0.59	421,232	24.02	75.33	0.65
Building F1	66,602	4.1	6656	95.75	111278	0.15	937,959	13.2	86.71	0.10
(FZ1) Building F4	2,466	3.93	39	96.03	1950	0.04	19,729	6.23	93.69	0.08
(FZ2) Street	1,717	9.26	1195	90.68	66	0.06	13,897	11.05	88.85	0.10
(TG5)	21,706	51.01	7448	38.92	6495	10.07	372,440	55.62	37.93	6.45
(Z) ^D	515	23.88	376	75.92	1928	0.20	43,392	12.75	87.25	0.0
Site R18	5,767	49.12	5184	49.32	2578	1.56	279,528	72.74	26.80	0.46
TOTAL	211,088	29.63	135944	68.90	229632	1.46	5,036,906	44.54	54.15	1.30

^A A handful of sherds (11, weight 595gm) are surface finds that do not come from the areas listed in the table, and have not been included in the discussion.

^B This category includes instances where the manufacture was simply not recorded, or it was impossible to determine because of surface slips or abraded surfaces; in Area T, for the sake of expediency, and because of the large quantity of body sherds, these were (unfortunately) counted and weighed without differentiating between methods of manufacture.

^C The records of Area B are largely missing the body sherd count and therefore misleadingly appears to have contained less pottery than other trenches excavated in depth. See Introduction for a more detailed explanation.

^D The records for Area Z are not complete. See Introduction for a more detailed explanation.

TABLE 9.2. BREAKDOWN OF THE HANDMADE AND WHEEL-MADE POTTERY FROM SITE R18, SHOWING ALSO THE RIM VESSEL EQUIVALENT.

Area	Sherds	WM%	RVE	HM%	RVE	UNK	Weight	WM%	HM%	UNK
(GD3)	726	46.83	1506	53.17	518	-	58,165	85.10	14.90	-
(HA1)	103	34.95	386	65.05	219	-	21,022	92.17	7.83	-
(HA2)	1,917	51.07	865	46.90	375	0.03	42,859	63.41	35.64	0.95
(J)*	2,895	49.53	2427	48.84	1,466	1.63	149,408	67.52	31.91	0.57
Total	5,767	49.12	5,184	49.32	2,578	1.56	279,528	72.74	26.80	0.45

* Ceramics from burials within Area J have not been broken down by grid square, as the squares adjoin each other and are in any case purely artificial demarcations.

onwards), and is rarely found with 8y on the base – only seven instances were recorded across the site, six in Area A and one in Area C.

In Tables 9.1 and 9.2 an attempt has been made to analyse the data relating to wheel-made and handmade pottery. Note the differences between the sherd count and weight percentages – on the whole, wheel-made wares are denser and thus weigh more than handmade vessels. It can also be surmised that the greater the sherd to weight ratio, the more disturbed the area, or the more fragile (poorly fired) are the vessels.

It is notable that in the entirely/early Napatan areas the proportion of wheel-made to handmade pots is heavily in favour of handmade, suggesting that it is only later in the Napatan period that (locally made?) wheel-made wares

become common. However, the usual caveat remains as to what use the areas have been put to, as this could affect the presence of particular wares.

Area A

Buildings A1-A6

The earliest phases of occupation predate the mud-brick buildings. Of these buildings, very little remained of Buildings A5 and A6, but much more substantial remains survived of Building A3, which was extensively modified and added to, being thereafter referred to as Building A4. The plan of Building A3 in particular and the construction techniques employed bear striking parallels to the architecture that flourished in the Kerma period as is well illus-

trated amongst the *Kerma Classique* structures excavated at Kerma (55km to the north of Kawa). Although it may be that there was some special reason why this structure was built in an archaising style, it is perhaps more plausible to suggest that this style of building predates the introduction of rectilinear mud-brick architecture across the town. The pottery associated with the pre-building deposits and those associated with the 'Kerma' style architecture are however typical Napatan RBR bowls, and contain nothing of a Kerma date or style.

In fact, the vast majority of the pottery found in Area A is Napatan in date. In the earliest levels there is no form that could definitely be attributed to the New Kingdom; the pottery from the pre-A3 levels consists entirely of handmade bowls and dishes (including some cooking pots), made of Nile silt (Fabrics 92 and 110) and very frequently decorated with a red band by the rim, both on the interior and exterior (RBRIE). Coarsewares with CRR (crackled rim) and some instances of 910 also occur. However, these forms are also common in later levels, making it impossible to see a great difference between the earlier and later levels from these coarsewares alone. The wheel-made forms that are found in association with the handmade wares in the upper levels belonging to Buildings A1 and A2 allow for dating those contexts firmly within the Napatan period.

There are also a few rare sherds of post-Napatan date, found in midden contexts and not directly related to the building phases. The late sherds include 2959x (AB4)23, with unusual slip-painted decoration, but as it was found in a rubbish deposit to the west of Building A1 it does not prove later occupation of the building. Of a similar date and from midden deposits also to the west of Building A1 are 2653x and 2653xa (3.6.1). One sherd only of Fabric 26, weighing 5gm, was found in a fairly late deposit of windblown sand in Building A2.

Another fabric that is a chronological indicator, Fabric 87, relating to Levantine amphorae imported in the Napatan period, occurs most prominently in Area A, both in the midden deposits to the west of Building A1, as well as in more secure contexts belonging to periods 1-4 in Buildings A2, A3 and in pre-A3 levels.

A considerable number of Napatan amphora sherds were found in the area, in Buildings A1-A4, in levels belonging to phases 4.1, 4.2.2, 6.1-2, 6.2-3, 6.3+, suggesting a solidly Napatan date for the full lifetime of all the excavated buildings within Area A. Parts of the almost complete Nile silt (Fabric 98) amphora 3221x (3.1.4) was found in a phase 4.1 context in Building A2, Room VII. Other amphora fragments found were made from Fabrics 102 and 113.

Area B

In Area B the proportion of wheel-thrown vessels is just over half of the total, while the proportion by weight is under half.

The exact dating is elusive; while there is a number of Napatan amphora rims and a handful of Levantine amphorae sherds present in rooms of Buildings B1, B5, B12 and B14, the more 'sophisticated' forms (e.g. 2536x [3.10.3], 2726x [3.12.5], 2769x [3.6.6] and 2784x [3.2.3]) largely

absent from Area A, may mean that occupation in this area is later than in A, or, more likely in view of the Napatan amphorae rims that occur in both areas, had a different use as domestic dwellings of the reasonably well-to-do.

Occupation in the area may have lasted as late as the early Meroitic, but not later than the 2nd century BC. This dating depends on the latest datable form, 2029x (3.5.2), but the parallels offer a wide and contrasting date range for this form.

In the sondage dug below Building B14 the pottery forms are consistently Napatan, including those from the lowest level reached, (BD3)32.

Area C

Approximately half the pottery recovered is wheel-made, taking into consideration both the sherd and weight counts; however, based on the RVE percentages, vastly more of the vessels represented are handmade, 78% vs. 22%.

Only six rims with RBRIE were found within the whole of Area C, in contrast with Area B, that otherwise has many forms in common with Area C.

There are several sherds of early(?) Meroitic date, but also a smallish number of Napatan date (amphora forms, decoration 1204y – the latter mainly found in Building C21). Most of the pottery in this area is made up of coarse cooking wares, but these differ from the coarsewares elsewhere on the site (with the exception of Area B), as most have a lid seating by the rim – a sign of different activities/cooking practices in this area, later in date than Areas A and F (excluding the kilns)?

Area F

The two kilns and surroundings

Only just over a fifth of the pottery from this area, grid squares (FQ), (FR), (FS) and (FT), is wheel-made. A considerable amount of red-banded rims (RBR) were found, belonging to the Napatan buildings cut through when the construction pits of the two kilns were made. The majority of the RBR pottery is handmade, with only about 1% wheel-made.

Dateable sherds found within the decayed mud bricks belonging to the kiln(s) are mostly Napatan in date, but form 3948x (3.2.9) is most probably early Meroitic.

The pottery that can be associated with the period of use of the kilns appears to be early Meroitic.

Building F1

This building lay within grid squares (FN), (FO) and (FP). The most common forms here were Napatan amphorae and RBRIE cups, bowls and dishes. The amphorae suggest a 7th century BC date.

Room XII abuts the north wall of Building F1 and the entrance is from the outside, so there is no direct link to the rest of the building. It was most likely used as a kitchen, judging by the hearths, bank of ovens and multitude of cooking pots found therein. Some of the same coarseware forms are present in the rooms of the main building, as

well as a few amphora sherds, thus suggesting that they are broadly contemporary.

(FZ1) – Building F4

Napatan. Similar pottery and fabrics to Building F1. The proportion of wheel-made pottery is very low, just as in Building F1 and in the ‘street’ (FZ2). This is in contrast to Area A, explained partly by the absence of wheel-made offering dishes. A different status and function of F4 may explain this. It must however be noted that only a very small part of this extremely large building was excavated and any conclusions drawn from the pottery and other finds assemblages recovered may be of little significance.

(FZ2) – Street

Napatan. Similar pottery and fabrics to Building F1. As this is an open area, not within a building, the pottery forms could be expected to consist of a more random selection, but nevertheless is consistently of Napatan character, with several amphorae sherds in Fabrics 102, 113 and 128, RBRIE bowls and dishes and cooking pots in ware 910.

Area T

(TG5) – Gateway into the temenos

There are 115 sherds weighing 14.3kg with RBR, of which 41/6,039gm are wheel-made (37% /42%), chiefly accounted for by jars with a red rim, different from other areas where it is bowls and cups that account for most of the red-banded rims.

A full range of dates is present, from the earliest Napatan period to the Meroitic. The lowest levels in the trench, the fills of the post-holes, do not contain pottery, and very little pottery and nothing datable was found in the silty surfaces above them, although there were a few sherds probably belonging to Napatan amphorae (coarseware rims 220x, 3276x, 3456x and 4271x in the level below). The foundation/construction trench [(TG5)117 (west side) and 114 (east side)] of the stone pavement in the stone gateway, contained pottery consistent with a Napatan date. The levels immediately above also contain Napatan forms (as would be expected), including amphorae rims and rims of the straight-necked, narrow-shouldered jars with a beaded rim (see 3.2.2), but the latter do not occur in earlier layers.

In the uppermost levels, which we would expect to be Meroitic, there are a number of forms that fit with this period, such as 3896x (3.1.2), 4390x (3.6.3), 4619x (3.2.11) in (TG5)12. However there are also a couple of rims that resemble Napatan forms, 2980x (3.1.2) and bread cone form 2633x (3.11.7), but these could be residual, and in any case we are dealing with a deposit close to the present-day surface, which could easily be contaminated.

Area Z

(ZH5) and (ZI6), Building ZI

No CRR nor RBR pottery was found in this area.

Only a few sherds (such as amphora rim 3030x, 3.1.8) that are clearly Napatan were found in this structure the

function of which remains uncertain. The coarsewares have been fired in a different way, using a different technique than the Napatan repertoire as seen in Area A and in Building F1, resulting in more oxidised vessels. A few forms, e.g. the lamp (?) with handle (3021x, 3.11.8), can confidently be dated to the early Meroitic period, which seems the most likely date of this building.

Site R18

The majority of the graves excavated across different areas of the cemetery are Meroitic in date; apart from the several graves in grid squares (GD3) and (HA2) that are Napatan in date, there is also a presence of Napatan sherds in the topsoil across most of the areas excavated. Likewise, some Neolithic and Kerma sherds were found in the windblown sand in Area J, but not directly associated with any of the burials investigated. In terms of the pottery that could be dated, grid square (GD3) ranges from the 7th century BC to the 3rd AD; (HA1) is early Meroitic, 4th century BC through the 1st century BC; (HA2) is early (7th century BC) to Meroitic and Area J is 2nd century BC - 1st century AD. This means that the excavated burials represent almost the full span of the Kushite period, albeit few burials were found with the grave goods intact.

Note on other dating

A number of ¹⁴C samples were analysed from Area A, grid squares (AC5), (AD5) (pre-Building A3 and Buildings A3 and A2) and grid square (TG5) (the *temenos* gateway). While these do not contradict the dates suggested for the ceramic corpus, neither do they help fix the dating more securely (Welsby 2023g). Apart from the earliest ¹⁴C date (most likely incorrect) which spans the 14th century BC, the others are clustered together, with the earliest being late 9th century BC (810-754 BC), which agrees with the dating of the pottery. Certainly no trace of an earlier occupation that could be identified as Kushite has been found.

The stamped mud sealings found in Building F1 and in Areas A, T and Z have been studied by Irene Vincentelli (forth.); unfortunately do not contain royal cartouches that would have allowed us to date the contexts they were found in. The use of the names of Anlamani and Aspelta do occur in Area A, but as they occur without cartouche or royal epithets they could belong to members of the royal entourage or to private individuals and not to the reign of the Kushite kings (Vincentelli, pers. comm.).

10. Concluding remarks

The areas excavated are widely spread across both the town site and the cemetery. What is interesting is how it would seem that the town was much larger in the Napatan period and appears to have shrunk in the Meroitic, becoming focused on the central area around the temples, extending more to the north, abandoning the south where the buildings of Areas A and B are found. The early Meroitic kilns are installed in an area previously occupied by Napatan buildings, later apparently abandoned and used for industrial purposes.

The most common type of pottery vessel recovered from Kawa is without doubt the cooking pots, followed by the utilitarian cups or bowls with a red band around the rim. The cooking pot shapes, fabrics and their surface treatment in general changed little between the Napatan and Meroitic periods – form 2039x (3.8.4) occurs in a wide range of contexts, for example. Few parallels have been found for most of the more distinctive forms, with the exception of the Napatan contexts at Kerma (Mohamed Ahmed 1992, *passim*). This may partly be due to the fact that few non-funerary Napatan contexts have been excavated (or published) to date, and there is a large range of forms that are not used as grave goods.

The functions of the Kawa ceramics

What was cooked and/or stored in the vessels found at Kawa – and how was food and drink served? Conversely, what forms, whether for cooking or storage, if any, are missing from the corpus?

Cooking pots – Most commonly these have slightly inverted rims, although straight-sided vessels also feature, perhaps with slightly different use. The ‘S’-shaped pots with open mouth may again have had a different use, the rim making them less practical for pouring out liquids or for retaining the heat while cooking. Only the inverted or straight-sided pots occasionally have had their bases thickened. Some were found still coated in soot from the fire, while others were clean, suggesting that not all coarseware vessels were used for actually heating/cooking food. In some instances, the body of the vessel, but not the base, would retain traces of soot, suggesting that the pot was set into the ground and the cooking fire was arranged around it (cf. 2000xa, Plate 3.7.2).

Serving of food – The dishes that are of a large enough size to be suitable as serving dishes or for use as communal bowls, the ‘*doka*’ (3.9.1-3.9.4) are crude, certainly not what we could call table wares. Perhaps these were of wood, similar to the pre-modern bowls used in the Fourth Cataract area, for example, or food was served in small dishes, *meze* style.

Serving of drink – The narrow Napatan beakers are quite rare, while the coarser type with a wider mouth are found in considerable quantities in Area A, but rarely elsewhere and are probably intended for ritual use. The RBR (red band by the rim) cups, either with inverted or vertical sides (3.7.4

& 3.7.5) must have been the common drinking vessel in the Napatan period. In the Meroitic, the fineware cups such as 4785x (3.6.2) would have made excellent drinking vessels, but these are of course very rare; more common wares would have been used in daily life (e.g. 3527x, 3.6.2).

Storage jars and bins – A discreet number of ‘stationary’ (wide-mouthed and thus unsuitable for transport) storage jars were found (e.g. 2719bx and 2792x in Area B, 2821x in Area A and 4650x in Area C [3.4.11]), but more commonly perhaps storage bins akin to the pre-modern *quseiba* were used, made from fabric 71, or unfired clay/mud (3.9.9 & 3.9.10 & Plate 3.9.1). Examples made from mud were found in a number of the excavated buildings (see Welsby 2023b, 39).

Storage jars with suspension holes – as seen in Section 3.4.6, a number of open-mouthed jars were found with at least one pair of suspension holes, for storing foodstuffs off the floor, and out of the way of animals (termites, mice or cats, for example). Such pots were found predominantly in Room III of Building A2, as well as in Area B (but of a slightly different form, found in Buildings B1, B5, B12, B13 and B14) and a few examples in grid square (TG5). A few rim fragments without the holes also occurred in Area C – as the forms are not complete, this does not exclude the possibility that the holes had been present. No other vessel types appeared to have suspension holes. This is not to say that suspending foodstuffs was not practised by other means; baskets may have been used instead of pots, or rope/string nets used to suspend the vessels (Plate 10.1).



Plate 10.1. Hanging pots in a modern qahwa.

Water containers – Water was, of course, readily available from the Nile, but few large vessels are present that could have been used for public or domestic water storage, comparable to the modern *zir*. Animal hides may have been used instead of permeable pots, and whatever needed washing most likely was brought to the river rather than *vice versa*. Judging by the range of pottery recovered at Kawa, it would seem that water for domestic use must mostly have been stored in medium-sized jars with a capacity of around 3.3 litres.

Bases – These are mostly round, rather than flat or ring-footed; most, though not all, ring bases are Meroitic in date (see above, section 3.12.3).

Lids – Custom-made lids are rare (cf. 3.11.10), but dishes could simply be reversed and used as lids. A number of types have a ledge by the rim to accommodate a lid, suggesting that there was an expectation of being able to seal the mouth of the vessels. However, vessels with a lid seating are not present in all domestic contexts, but are particularly common in Area C, suggesting that this ‘innovation’ was introduced at the end of the Napatan period.

Vessels with spouts – Apart from the so-called feeder cups, spouts are also rare. The pinched ‘trefoil’ type of rim common in medieval pitchers was apparently not used, and within the present repertoire there is no form that could have been used specifically for serving liquids with a minimum amount of spillage.

Vessels with handles – With the exception of amphorae there are few forms with handles: there is a small number of jugs or ewers with handles (cf. 3.2.11). Nor are there cooking pots with handles (though a few have lugs, see 3.7.13) or frying pans – admittedly a rare occurrence in antiquity outside the Graeco-Roman world. Forms with handles are on the whole relatively rare, with the clear exception of the Napatan amphorae (locally made or from Egypt) and the relatively few other imported amphorae, but few of the many handles found separately from the vessel body can be related to a particular form, with the exception of the Napatan amphora handles (2042x, etc., 3.12.4). These have been left together with the other handles dissociated from the rims as they could also belong to types of jar, see 4032x (3.5.1), for example.

Colanders – There is one sherd, 1087y (4.1) from (CE5)1, and another example from (ZH5). The coarse vessels with large pre-firing holes near the base may also have been used as colanders, but probably liquids were simply drained carefully by tilting the vessel. Multiple fine holes in the base of a coarse cooking pot would have weakened the vessel, one reason that the not very strong cooking wares used at Kawa would not have been suitable. The rarity of colanders would also rule out the preparation of steamed food dishes, such as couscous, for example.

Lamps – Although it has been argued that RBRIE (red band by rim, interior and exterior) bowls or cups were adapted for use as rudimentary oil lamps (Chapters 3.7 and 6), no unequivocally purpose-made lamps were recovered at Kawa. If the adapted bowls were lamps, this suggests a brief influx of a different technology that was not popularised, possibly because of a shortage of suitable fuel.

The issue of imported Nile clay wares from Egypt vs. locally produced wheel-made forms

While the cooking pots and red-rimmed bowls and cups are almost always handmade, wheel-made vessels (of Nile clay, not marls) occur both in the Napatan and Meroitic periods; their fabrics could easily have been sourced

locally. The wheel-made vessels, other than the crudely formed offering cups and dishes (3.10.5-3.10.7), are fired to a higher temperature however, offering the possibility that a superior kiln and firing technology could have been available at Kawa from at least the mid-Napatan period onwards (so far not found; the two kilns in Area F appear not to have been used for firing ceramics, as they did not yield any pottery wasters).

‘Egyptian’ forms, not including the imported amphorae of the Napatan period, are not so easy to trace. Distinctive forms such as the beakers at 3.6.6 (upper half of the page), the various jars with complex rims in sections 3.4 or 3.5 do not, on the whole, have parallels in Egypt (2029x, 3.5.2, is an exception). The proportion of imported Egyptian marl vessels vs. locally produced (local to Kawa or Nubia) is very much to the advantage of the local Nile silt fabrics. Marls represent approximately 0.5% of all the pottery recorded, and the imported non-marls but also non-silts about the same again. What proportion of the wheel-made silt fabrics is imported is more difficult to assess. Unusual and distinctive forms with close parallels amongst vessels excavated at Egyptian sites are likely to be imports, especially in the absence of any local Napatan kilns that demonstrably produced such forms. Among these possible imports are 2029x, but it should not be excluded that they could have been made within Nubia.

Other imported pottery types

Apart from the Napatan amphorae from Egypt, imports within the Kushite period at Kawa are made up of Levantine amphorae in the Napatan and rare instances of Aegean amphorae, as well as the interesting unusual Dressel 2-4 variant, (all 3.2.1) in the early Meroitic. With the exception of the latter instance we only have fragments of these vessels; the areas where they appear to have been manufactured fit well with what could be expected within the period, but their rarity is also noteworthy. We are left with the impression that, rather than representing regular trade, they were brought in piecemeal, as *curiosa*.

Future direction of research

It goes without saying (but should still be stated) that the chronology of especially Napatan but also Meroitic pottery needs a great deal of further work.

This volume has focused principally on the forms and their surface treatment, decoration and graffiti; although the fabrics are described and those that are clearly imported from outside Nubia have been highlighted, a great deal more could be done. In particular it would be interesting to learn to what extent the various Nile silt fabrics that look dissimilar really are different from each other, in terms of clay and inclusions. Are their apparent differences due to variations in firing temperature, or the mixing of individual clay batches, or do they have different origins? Conversely, do the most common fabrics, such as 110 or 92, vary between different areas on the site, suggesting perhaps different potters at work, or can the differences be ascribed to chronological factors? Tracing concentrations of the same

fabric variation across the site and within the hinterland of Kawa would allow us to learn more about the organisation of local/domestic pottery production.

A more fine-tuned analysis of the common wheel-made forms made of Nile silt could also begin to unravel to what extent coarsewares may have been imported or locally made.

Among other matters that would benefit from further research is a more in-depth consideration of possible influences from the Mediterranean on the pottery forms in the Napatan period. Some similarities have been pointed out, possibly far-fetched, but the matter merits further investigation. After all, if actual vessels from far afield found their way to Kawa, local copies could have been made of vessels seen abroad.

11. Bibliography for Volume III

- Amorós Ruiz, V. and S. Gutiérrez Lloret 2020. 'Ceramics in transition: ceramics from the first Islamic period in the western Mediterranean - the example of al-Andalus', *Libyan Studies* 51, 99-125.
- Anderson, J. R. and D. A. Welsby (eds) 2014. *The Fourth Cataract and Beyond. Proceedings of the 12th International Conference for Nubian Studies*. British Museum Publications on Egypt and Sudan I. Leuven – Paris – Walpole, MA.
- Anderson-Stojanović, V. R. 1987. 'The Chronology and function of ceramic unguentaria', *American Journal of Archaeology* 91.1, 105-122.
- Aston, D. A. 1999. *Elephantine XIX. Pottery from the Late New Kingdom to the Early Ptolemaic Period*. Archäologische Veröffentlichungen 95. Mainz.
- Aston, D. A. 2003. 'The Theban West Bank from the Twenty-Fifth Dynasty to the Ptolemaic Period', in N. Strudwick and J. H. Taylor (eds), *The Theban Necropolis. Past, Present and Future*. London, 138-166.
- Aston, D. A. 2007. 'Amphorae, storage jars and kegs from Elephantine. A brief survey of vessels from the eight-seventh centuries BC to the seventh-eighth centuries AD', *Cahiers de la Céramique Égyptienne* 8, 419-445.
- Baldıran, A. 1998 'Stratonikeia 'dan Unguentariumlar', *Selçuk Üniversitesi, Sosyal Bilimler Enstitüsü Dergisi* 4, 335-355.
- Bagińska, D. 2005. 'Amphora imports in Nubia', *Gdańsk Archaeological Museum African Reports* 3, 15-36.
- Bagińska, D. 2018. 'Meroitic pottery from Temple B 560 at Jebel Barkal', in M. Honegger (ed.), *Nubian Archaeology in the XXIst century. Proceedings of the Thirteenth International Conference for Nubian Studies, Neuchâtel, 1st-6th September 2014*. Publications de la Mission Archéologique Suisse à Kerma 1. Orientalia Lovaniensia Analecta 273. Leuven – Paris – Bristol, CT, 489-504.
- Bąkowska, G. 2010. 'Meroitic pottery from Gebel Barkal. Preliminary remarks on the results of seasons 2005 and 2005', in Godlewski and Łajtar (eds), 187-204.
- Bashir, M. S. and R. David 2011. 'Meroitic Pottery from Excavations of the Cemetery at Berber', *Der Antike Sudan* 22, 121-128.
- Bashir, M. S. and R. David 2015. 'The Meroitic Cemetery at Berber. Recent Fieldwork and Discussion on Internal Chronology', *Sudan & Nubia* 19, 97-105.
- Bates, O. and D. Dunham 1927. 'Excavations at Gammai', *Harvard African Studies* 8. Cambridge, Mass., 1-122.
- Belgiorno, M. R. 2020. 'Ancient Distillation and Experimental Archaeology: about the Prehistoric Apparatuses of Tepe Gawra', *Exarc Journal* 2020/2 <https://exarc.net/ark:/88735/10508>.
- Bettles, E. A. 2003. *Phoenician Amphora Production and Distribution in the Southern Coastal Levant. A multi-disciplinary investigation into carinated-shoulder amphorae of the Persian period (539–332 BC)*. BAR Int. Ser. 1183. Oxford.
- Binder, M., N. Spencer and M. Millet 2011. 'Cemetery D at Amara: the Ramesside period and its aftermath', http://www.britishmuseum.org/research/online_journals/bmsaes/issue_16/binder_spencer_millet.aspx
- Bonnet, C. (ed.) 1990. *Kerma, royaume de Nubie*. Geneva.
- Bonnet, C. 2002. 'The 2001-2002 season of excavation at Kerma: a summary', *Sudan & Nubia* 6, 30-31.
- Bonnet, C. and M. el-Tayeb 1991. 'Une tombe méroïtique de la ville ancienne', *Genava* n.s. 39, 29-34.
- Boulet, S. 2017. 'Les productions céramiques de la XXV^e Dynastie dans le secteur du temple de Ptah à Karnak', *Bulletin de liaison de la Céramique Égyptienne* 27, 53-62.
- Boulet, S. 2017b. 'Nouvelles discussions sur l'apparition et l'usage du tour rapide en Égypte', *Bulletin de liaison de la Céramique Égyptienne* 27, 289-328.
- Boulet, S. 2018. 'Interactions entre les productions céramiques égyptiennes et nubiennes du viii^e au vi^e s. av. J.-C.', *Cahiers de la Céramique Égyptienne* 11, 153-175.
- Boulet, S. 2018b. 'Ceramic Industry Developments in the Theban Area during the Twenty-fifth Dynasty: Between Traditions and Innovations', in E. Pischikova, J. Budka and K. Griffin (eds), *Thebes in the First Millennium BC: Art and Archaeology of the Kushite Period and Beyond*. London, 335-356.
- Budka, J. 2007. 'Documentation and excavation of dome and crevice graves in Kirbekān', in *Proceedings of the Second International Conference on the Archaeology of the Fourth Nile Cataract. Berlin, 4-5 August 2005. Meroitica* 23, Wiesbaden, 73-90.
- Cedro, A. 2014. 'Oil lamps in the liturgical and in common folk practice. The upper church at Banganarti - a case study', in B. Żurawski, *Kings and Pilgrims. St Raphael Church II at Banganarti, mid-eleventh to mid-eighteenth century*. Nubia V / Banganarti 2. Warsaw, 327-340 (341-364 bibliography).
- David, R. 2012. 'Saï Méroïtique, quelques illustrations du matériel céramique', *CRIPPEL* 29, 67-78.
- David, R. and V. Francigny 2018. 'Les céramiques importées à Sedeinga et la question des «échanges à longue distance» dans le royaume de Méroé', *Cahiers de la Céramique Égyptienne* 11, 255-278.
- David, R. (ed.) 2018. *Céramiques Égyptiennes au Soudan Ancien. Importations, Imitations et Influences. Cahiers de la Céramique Égyptienne* 11.
- David, R. 2018b. 'Funerary Ceramics and Meroitic Economy: A First Insight', in Honegger 2018, 481-488.
- David, R. 2019. 'Ceramic industries of Meroitic Sudan', in Raue 2019, 875-895.
- David, R. and M. Evina 2016. 'Introduction à l'évolution des chaînes opératoires des céramiques méroïtiques', *Dotawo: A Journal of Nubian Studies* 3, 83-126.
- Derin, Z. 1999. 'Potters' Marks of Ayanis Citadel, Van', *Anatolian Studies* 49, 81-100.
- Devries, C. E. 1973. 'An enigmatic pottery form from Meroitic Nubia', *Journal of Near Eastern Studies* 32, no. 1/2, 62-69.
- Dunham, D. 1950. *The Royal Cemeteries of Kush. I. El Kurru*. Boston.
- Dunham, D. 1955. *The Royal Cemeteries of Kush II. Nuri*. Boston.
- Dunham, D. 1957. *Royal Cemeteries of Kush IV; Royal Tombs at Meroe and Barkal*. Boston.
- Dunham, D. 1963. *Royal Cemeteries of Kush V. The West and South Cemeteries at Meroe*. Boston.
- Dunham, D. 1965. 'A Collection of 'Pot Marks' from Kush and Nubia', *Kush* 13, 131-147.
- Edwards, D. N. 1998. *Gabati. A Meroitic, Post-Meroitic and Medieval Cemetery in Central Sudan. Vol. 1*. Sudan Archaeological Research Society Publication no. 3. London.

- Edwards, D. N. 2014. 'Early Meroitic Pottery and the creation of an early imperial culture?', in A. Lohwasser and P. Wolf (eds), *Ein Forscherleben zwischen den Welten Zum 80. Geburtstag von Steffen Wenig*. Der antike Sudan. Mitteilungen der Sudanarchäologischen Gesellschaft zu Berlin e.V. Berlin, 51-63.
- Evina, M. 2018. 'Painted kraters from the Meroitic city of Muweis: some elements of understanding', *Cahiers de la Céramique Égyptienne* 11, 233-253.
- Fantusati, E., E. Kormysheva and S. Malykh 2014. 'Abu Erteila - An archaeological site in the Butana region', in A. Lohwasser and P. Wolf (eds), *Ein Forscherleben zwischen den Welten Zum 80. Geburtstag von Steffen Wenig*. Der antike Sudan. Mitteilungen der Sudanarchäologischen Gesellschaft zu Berlin e.V. Berlin, 65-94, 422-423.
- Francigny, V. 2014. 'An elite Meroitic cemetery at Sai Island', in Anderson and Welsby (eds), 797-803.
- French, P. 1992. 'A preliminary Study of pottery in Lower Egypt in the Late Dynastic and Ptolemaic periods', *Cahiers de la Céramique Égyptienne* 3, 83-93.
- French, P. 2004. 'Distinctive Pottery from the Second Half of the 6th century BC', *Cahiers de la Céramique Égyptienne* 7, 91-97.
- Gallorini, C. 2009. 'Incised marks on pottery and other objects at Kahun', in B. Haring and O. Kaper (eds), *Pictograms or Pseudo Script? Non-textual identity marks in practical use in Ancient Egypt and elsewhere, Proceedings of a conference in Leiden 19-20 December 2006*. Leiden, 107-142.
- García Guinea, M. A. and J. Teixidor 1965. *La Necropolis Meroitica de Nellulah (argin sur, Sudan)*. Comité Español de la UNESCO para Nubia. Memorias de la misión arqueológica VI. Madrid.
- Glatz, C. 2012. 'Bearing the Marks of Control? Reassessing Pot Marks in Late Bronze Age Anatolia', *American Journal of Archaeology* 116.1, 5-38.
- Godlewski, W. and A. Łajtar (eds) 2010. *Between the Cataracts. Proceedings of the 11th Conference of Nubian Studies, Warsaw University, 27 August - 2 September 2006*. Kraków/Warsaw.
- Griffith, F. Ll. 1922. 'Oxford Excavations in Nubia (continued)', *Liverpool Annals of Archaeology and Anthropology* 9, 67-124, pls IV-LXII.
- Griffith, F. Ll. 1923. 'Oxford Excavations in Nubia, XVIII. The Cemetery of Sanam', *Liverpool Annals of Archaeology and Anthropology* 10, 73-171.
- Griffith, F. Ll. 1924. 'Oxford Excavations in Nubia, XXX-XXXIII', *Liverpool Annals of Archaeology and Anthropology* 11, 141-180.
- Griffith, F. Ll. 1925. 'Oxford Excavations in Nubia, XXXIV-XXXIX', *Liverpool Annals of Archaeology and Anthropology* 12, 57-172.
- Heidorn, L. 1994. 'Historical implications of the pottery from the earliest tombs at el-Kurru', *Journal of the American Research Centre in Egypt* 31, 115-131.
- Heidorn, L. 2018. 'The Boston Museum of Fine Arts Pottery from the Twenty-Fifth Dynasty tombs at el-Kurru and Nuri', in Honegger 2018, 317-332.
- Heidorn, L. 2018b. 'The 6th century BC imported amphorae at Dorginarti', *Cahiers de la Céramique Égyptienne* 11, 189-207.
- Hembold-Doyé, J. and A. Seiler 2019. *Die Keramik aus dem Friedhof S/SA von Aniba (Unternubien)*. Berlin - Boston.
- Hoffman, I. 1991. 'Der Wein und Ölexport im Meroitischen Reich', in W. V. Davies (ed.), *Egypt and Africa. Nubia from Prehistory to Islam*. London, 234-245.
- Hoffman, I. 1994. 'Zu Einigen Schöpf- und Siebgeräten bei den Meroiten', in M. Bietak, J. Halaubek, H. Mukarovsky and H. Satzinger (eds), *Zwischen der beiden Ewigkeiten. Festschrift Gertrud Thausing*. Wien, 73-90.
- Honegger, M. (ed.) 2018. *Nubian Archaeology in the XXIst century. Proceedings of the Thirteenth International Conference for Nubian Studies, Neuchatel, 1st-6th September 2014*. Leuven - Paris - Bristol, Ct.
- Jacquet-Gordon, H. 1981. 'A Tentative Typology of Egyptian Bread Moulds', in D. Arnold (ed.), *Studien zur altägyptischen Keramik*. Mainz am Rhein, 11-24.
- Jacquet-Gordon, H. no date. unpublished Mss. 'Pottery from the Twenty-First Dynasty to the Ptolemaic Period at Karnak North'.
- Jesse, F. and Kuper, R. 2006. 'Napata in the West? - The Gala Abu Ahmed Fortress in the Lower Wadi Howar (NW-Sudan)', *Archéologie du Nil Moyen* 10, 135-159.
- Jesse, F., C. Gradel and F. Derrien 2015. 'Archaeology at Selima Oasis, Northern Sudan - recent research', *Sudan & Nubia* 19, 161-169.
- Karberg, T. 2015. 'In a Royal Cemetery of Kush: Archaeological Investigations at El-Kurru, Northern Sudan, 2014-15. Some remarks on the stonemasons' marks in the mortuary temple', *Sudan & Nubia* 19, 68-69.
- Kirwan, L. P. 1936. 'Preliminary Report of the Oxford University Excavations at Kawa, 1935-1936', *Journal of Egyptian Archaeology* 22.2, 199-211.
- Kirwan, L. P. 1955. 'Account of the Excavations, 1935-6', in M. F. Laming Macadam. *The Temples of Kawa. II. History and Archaeology of the Site*. Oxford, 207-237.
- Kleinitz, C. 2009. 'Meroitic "property marks" in Fourth Nile Cataract rock art? A re-evaluation of an enigmatic class of graphic markings', in B. J. J. Haring and O. E. Kaper (eds), *Pictograms or Pseudo Script? Non-textual Identity Marks in Practical Use in Ancient Egypt and Elsewhere*. Egyptologische Uitgaven XXV. Leiden, 179-198.
- Klimaszewska-Drabot, E. 2003. 'Proto-Kushite (?) ceramics, and archaeological enigma', in Żurawski 2003, 438-441.
- Küçükeren, C. C. 2019. *The Carians overseas. Egypt. Iran. Israel*. Istanbul.
- Laming Macadam,¹ M. F. 1955. *Temples of Kawa II. History and Archaeology of the site*. Vols I & II. Oxford.
- Lohwasser, A. 2010. *The Kushite cemetery of Sanam. A non-royal burial ground of the Nubian capital, c. 800-600 BC*. London.
- Lynch, K. M. 2011. *The Symposium in Context. Pottery from a Late Archaic House near the Athenian Agora*. The American School of Classical Studies at Athens.
<http://www.jstor.org/stable/41363086>
- Malykh, S. 2017. 'Marks on Meroitic Pottery from Abu Erteila: The Problem of Interpretation', *Beiträge zur Sudanforschung* 12, 193-211.
- Masson, O. 1978. *Carian Inscriptions from North Saqqâra and Buhen*. with contributions by G. T. Martin and R. V. Nicholls. Texts from Excavations, 5, edited by T. G. H. James. Egypt Exploration Society, London.
- McFadden, G. H. 1946. 'A Tomb of the Necropolis of Ayios Ermoyenis at Kourion', *American Journal of Archaeology* 50, No. 4, 449-489.

¹ Usually referenced as Macadam. However, it has been brought to the attention of SARS by the son of the author that the correct surname is Laming Macadam.

- Medelhavsmuseet (Stockholm)/Världskulturmuseerna Medelhavet. Carlotta Database for the museum collections.
<https://collections.smvk.se/carlotta-vkm/web>
- Mohamed Ahmed, Salah el-Din 1992. *L'agglomération Napatéenne de Kerma. Enquête archéologique et ethnographique en milieu urbain*. Paris.
- Museum of Fine Arts, Boston. Museum online collections.
<https://collections.mfa.org/collections>
- Näser, C. 2004 'The small finds', in Shinnie and Anderson (eds), 215-350.
- Nowotnick, U. 2018. 'Napatan Ceramics from the excavations at the Royal Baths in Meroe', *Cahiers de la Céramique Égyptienne* 11, 209-232.
- Orzechowska, M. 2003. 'Preliminary report on the pottery from the Soniyat Temple', in Żurawski 2003, 442-447.
- Phillips, J. 2003. 'An overview of the ceramics', in Żurawski 2003, 387-437.
- Phillips, J. 2004. 'Islamic Pottery in the Middle Nile', *Azania* 39, 58-68.
- Phillips, J. 2010. 'Preliminary analysis of 'mat' - and 'basket' - impressed ceramics from the Southern Dongola Reach Survey', in Godlewski and Łajtar (eds), 227-236.
- Raue, D. (ed.) 2019. *Handbook of Ancient Nubia*. 2 Vols. Berlin/Boston.
- Redford, S. and D. B. Redford 1989. 'Graffiti and Petroglyphs old and new from the Eastern Desert', *Journal of the American Research Center in Egypt* 26, 3-49.
- Reisner, G. A. 1918. 'Preliminary Report on the Harvard-Boston excavations at Nūri: the kings of Ethiopia after Tirhaqa'. *Harvard African Studies* 2, 1-64, figs 1-54, pls I-XVII.
- Reisner, G. A. 1923. *Excavations at Kerma*. Parts I-III. *Harvard African Studies* 5. Cambridge, Mass.
- Riley, J. A. 1979. 'Coarse Pottery', in J. A. Lloyd (ed.) *Excavations at Sidi Khrebish Benghazi (Berenice)* Vol. II. Tripoli, 91-467.
- Rilly, C. 2007. *La langue du royaume de Méroé*. Paris.
- Rilly C. 2011. 'Les chouettes ont des oreilles. L'inscription méroïtique hiéroglyphique d'el-Hobagi REM 1222', in V. Rondot, F. Alpi and F. Villeneuve (eds), *La pioche et la plume. Autour du Soudan, du Liban et de la Jordanie. Hommages archéologiques à Patrice Lenoble*. Paris, 481-499.
- Rilly, C. and V. Francigny 2018. 'Closer to the Ancestors. Excavations of the French Mission in Sedeinga 2013-2017', *Sudan & Nubia* 22, 65-74.
- Rilly, C., V. Francigny and R. David 2020. 'Collective graves and ba-statues. The 2018 and 2019 campaigns at Sedeinga', *Sudan & Nubia* 24, 72-90.
- Robertson, J. H. and E. M. Hill 2004. 'The Meroitic Pottery Industry', in Shinnie and Anderson (eds), 109-211.
- Rose, P. J. 1998. 'The Meroitic Pottery', in Edwards 1998, 142-177.
- Rose, P. J. 2017. 'Sesebi: Ceramics, Chronology And Society', in N. Spencer, A. Stevens and M. Binder (eds), *Nubia in the New Kingdom. Lived experience, pharaonic control and indigenous traditions*. Leuven – Paris – Bristol, Ct., 465-473.
- Ruffieux, P. 2007. 'Ensembles céramiques napatéens découverts durant les campagnes 2005-2006 et 2006-2007 à Doukki Gel (Kerma)', *Genava* n.s. 55, 223-239.
- Sacco, V. 2020. 'The Palermitan ceramic production from the ninth to the eleventh century', *Libyan Studies* 51, 74-86.
- Shinnie, P. L and J. R. Anderson (eds) 2004. *The Capital of Kush 2. Meroe Excavations 1973-1984*. Meroitica 20, Wiesbaden.
- Spence, K and P. Rose 2014. 'Fieldwork at Sesebi 2010', in Anderson and Welsby (eds), 409-415.
- Török, L. 1987. 'Painted Meroitic Pottery: Problems of Chronology and Style', *Beiträge zur Sudanforschung* 2, 75-106.
- Török, L. 1990. Catalogue entries 357, 358 in Bonnet 1990, 239.
- Török, L. 1997. *Meroe City, an Ancient African Capital. John Garstang's Excavations in the Sudan*. Egypt Exploration Society Occasional Publication 12, 2 vols, London.
- Vercoutter, J. 1970. *Mirgissa I*. Paris.
- Vila, A. 1967. *Aksha II. Le cimetière Méroïtique d'Aksha*. Paris.
- Vila, A. 1980. *La prospection archéologique de la vallée du Nil, au sud de la cataracte de Dal*. 12. *Nécropole de Missiminia. I. Les sépultures napatéennes*. Paris.
- Vila, A. 1982. *La prospection archéologique de la vallée du Nil, au sud de la cataracte de Dal*. 13. *Nécropole de Missiminia. II. Les sépultures méroïtiques*. Paris.
- Vincentelli, I. 2001. 'Il "Tesoro" di Sanam (Sudan)', *ISIMU: Revista sobre Oriente Próximo y Egipto en la antigüedad* 4, 75-92.
- Vincentelli, I. 2006. *Hillat el-Arab. The joint Sudanese-Italian expedition in the Napatan region, Sudan*. Sudan Archaeological Research Society Publications 15, London.
- Vincentelli, I. 2018. 'Long distance trade: The evidence from Sanam', in Honegger (ed), 127-134.
- Vincentelli, I. 2018b. 'Egyptian Pottery in the Sanam Royal Stores', *Cahiers de la Céramique Égyptienne* 11, 177-187.
- Vincentelli, I. forth. 'The mud sealings and seal impressions', in Welsby (ed.) forth.
- Welsby, D. A. (ed.) 2023a. *Gematon: Living and Dying in a Kushite Town on the Nile. Volume I. Excavations at Kawa, 1997-2018*. Sudan Archaeological Research Society Publication Number 27. Oxford.
- Welsby, D. A. 2023b. 'The Kushite town of Gematon', in Welsby (ed.) 2023a, 8-43.
- Welsby, D. A. 2023c. 'Excavations of the painted shrine and other buildings in Area A', in Welsby (ed.) 2023a, 44-78.
- Welsby, D. A. 2023d. 'Excavations in Area F – Building F1, adjacent streets and Building F11', in Welsby (ed.) 2023a, 129-153.
- Welsby, D. A. 2023e. 'Excavations in Area F – grid squares (FQ3), (FQ4), (FR3), (FR4), (FS3) and (FT3)', in Welsby (ed.) 2023a, 154-168.
- Welsby, D. A. 2023f. 'Excavations within the Kushite cemetery at Gematon (site R18)', in Welsby (ed.) 2023a, 194-359.
- Welsby, D. A. 2023g. 'Radiocarbon dating', in Welsby (ed.) 2023a, 413-414.
- Welsby, D. A. (ed.) forth. *Gematon: Living and Dying in a Kushite Town on the Nile. Volume II. The Artefacts*. Sudan Archaeological Research Society Publication. Oxford.
- Welsby, D. A. and J. H. Taylor forth. 'The Small Finds', in Welsby (ed.) forth.
- Welsby Sjöström, I. 2001. 'The Pottery from the Survey' in D. A. Welsby, *Life on the Desert Edge. Seven thousand years of settlement in the Northern Dongola Reach, Sudan*. Sudan Archaeological Research Society Publication 7. London, 230-348.
- Wendrich, W. forth. 'Basketry and Matting', in Welsby (ed.) forth.
- Wenig, S. 2019. 'Art of the Meroitic Kingdom', in Raue (ed.), 847-873.
- Williams, B. B. 1985. 'A Chronology of Meroitic Occupation Below the Fourth Cataract', *Journal of the American Research Center in Egypt* 22, 149-195.

- Williams, B.B, 1990. *Twenty-Fifth Dynasty and Napatan remains at Qustul: Cemeteries W and V*. The University of Chicago Oriental Institute Nubian Expedition, Volume VII. Chicago.
- Williams, B.B, 1991. *Meroitic Remains from Qustul Cemetery Q, Ballana Cemetery B, and a Ballana Settlement. Part 1: Text and Figures*. The University of Chicago Oriental Institute Nubian Expedition, Volume VIII. Chicago.
- Wolf, P. 2015 'The Qatar-Sudan Archaeological Project – The Meroitic Town of Hamadab and the Palaeo-Environment of the Meroe region', *Sudan & Nubia* 19, 115-131.
- Woolley, C. L. and D. Randall-MacIver 1910. *Karanog. The Romano-Nubian Cemetery. Eckley B. Coxe Junior Expedition To Nubia*. Vols III (Text) and IV (Plates). Philadelphia.
- Żurawski, B. 2003. *SDRS 1. Survey and excavations between Old Dongola and Ez-Zuma*. Nubia 2. Warsaw.
- Żurawski, B. 2005. 'The Temple of Soniyat, 1991-2002', *Gdańsk Archaeological Museum African Reports* 3, 289-302.



Recent Publications of the Sudan Archaeological Research Society

THE ARCHAEOLOGICAL SURVEY OF SUDANESE NUBIA 1963–69.
THE PHARAONIC SITES

by

D. N. Edwards and A. J. Mills 2020

TRAVELLING THE KOROSKO ROAD
ARCHAEOLOGICAL EXPLORATION IN SUDAN'S EASTERN DESERT

by

W. V. Davies and D. A. Welsby (eds) 2020

SUDAN ARCHAEOLOGICAL RESEARCH SOCIETY

ARCHAEOPRESS www.archaeopress.com