

# COMRADELY OBJECTS

DESIGN AND MATERIAL CULTURE IN  
SOVIET RUSSIA, 1960s – 80s

Yulia Karpova



# Comradely objects



Manchester University Press

*also available in the series*

**Windows for the world**

Nineteenth-century stained glass and the international exhibitions, 1851–1900

JASMINE ALLEN

**The matter of Art**

Materials, practices, cultural logics, c.1250–1750

EDITED BY CHRISTY ANDERSON, ANNE DUNLOP

AND PAMELA H. SMITH

**European fashion**

The creation of a global industry

EDITED BY REGINA LEE BLASZCZYK AND VÉRONIQUE POUILLARD

**The culture of fashion**

A new history of fashionable dress

CHRISTOPHER BREWARD

**The factory in a garden**

A history of corporate landscapes from the industrial to the digital age

HELENA CHANCE

**'The autobiography of a nation'**

The 1951 Festival of Britain

BECKY E. CONEKIN

**The culture of craft**

Status and future

EDITED BY PETER DORMER

**Material relations**

Domestic interiors and the middle-class family, 1850–1910

JANE HAMLETT

**Arts and Crafts objects**

IMOGEN HART

**Interior decorating in nineteenth-century France**

The visual culture of a new profession

ANCA I. LASC

**Building reputations**

CONOR LUCEY

**The material Renaissance**

MICHELLE O'MALLEY AND EVELYN WELCH

**Bachelors of a different sort**

Queer aesthetics, material culture and the modern interior

JOHN POTVIN

**Crafting design in Italy**

From post-war to postmodernism

CATHARINE ROSSI

**Chinoiserie**

Commerce and critical ornament in eighteenth-century Britain

STACEY SLOBODA

**Material goods, moving hands**

Perceiving production in England, 1700–1830

KATE SMITH

**Hot metal**

Material culture and tangible labour

JESSE ADAMS STEIN

**Ideal homes, 1918–39**

Domestic design and suburban Modernism

DEBORAH SUGG RYAN

**The study of dress history**

LOU TAYLOR

**STUDIES IN  
DESIGN  
& MATERIAL  
CULTURE**

general editors

*Christopher Breward*

and

*James Ryan*

founding editor

*Paul Greenhalgh*

# **Comradely objects**

Design and material culture in Soviet Russia,  
1960s–80s

Yulia Karpova

Manchester University Press

Copyright © Yulia Karpova 2020

The right of Yulia Karpova to be identified as the author of this work has been asserted by her in accordance with the Copyright, Designs and Patents Act 1988.

An electronic version of this book is also available under a Creative Commons (CC-BY-NC-ND) licence, thanks to the support of Aarhus Universitet, which permits non-commercial use, distribution and reproduction provided the author and Manchester University Press are fully cited and no modifications or adaptations are made. Details of the licence can be viewed at <https://creativecommons.org/licenses/by-nc-nd/4.0/>

Published by Manchester University Press  
Altrincham Street, Manchester M1 7JA  
[www.manchesteruniversitypress.co.uk](http://www.manchesteruniversitypress.co.uk)

British Library Cataloguing-in-Publication Data  
A catalogue record for this book is available from the British Library

ISBN 978 1 5261 3987 0 hardback  
ISBN 978 1 5261 3986 3 open access

First published 2020

The publisher has no responsibility for the persistence or accuracy of URLs for any external or third-party internet websites referred to in this book, and does not guarantee that any content on such websites is, or will remain, accurate or appropriate.

*Cover image:* Boris Smirnov, 'Tea Couple', 1966. Experimental workshop of Ceramics and sculpture factory in Lviv. © Ensemble Kuskovo.

Typeset in 10/12.5 Compatil Text by  
Servis Filmsetting Ltd, Stockport, Cheshire

To my friends, near and far



# Contents

<i>List of plates</i>	viii
<i>List of figures</i>	x
<i>Acknowledgements</i>	xiii
<i>Abbreviations and acronyms</i>	xvi
<i>Note on transliteration and translation</i>	xvii
Introduction: Soviet things that talk	1
<b>1</b> The aesthetic turn after Stalin	24
<b>2</b> Technical aesthetics against the disorder of things	65
<b>3</b> Objects of neodecorativism	93
<b>4</b> From objects to design programmes	118
<b>5</b> A new production culture and non-commodities	159
Epilogue	199
<i>Select bibliography</i>	204
<i>Index</i>	210



# Plates

- 1 Double page spread in the journal *Dekorativnoe Iskusstvo SSSR* 10 (1967), 40–1. Left: M. Primachenko, decorative painting, Bolotnia, Kiev oblast, 1965. Right: Mikhail Posokhin et al., COMECON building at Novyi Arbat in Moscow, 1967. © Dialogue of Arts journal.
- 2 Teapots ‘Tundra’, USSR, porcelain, overglaze painting and gilding, 1959. © Museum of Moscow.
- 3 Ekaterina Ianovskaia, set of bottles and glasses, ‘Rainbow’, coloured and colourless lead glass, incising, 1964–72. Produced at Leningrad Factory of Artistic Glass. © Yelagin Palace Museum of Russian decorative and applied arts and interior of XVIII–XX centuries.
- 4 Boris Smirnov, decorative sculpture, ‘Tea Couple’, coloured ground and transparent non-lead glass, blown with hot applications, 1966. Experimental workshop of ceramics and sculpture factory in Lviv. © Ensemble Kuskovo.
- 5 Boris Smirnov, composition, ‘Festive Table’, fragment, coloured and colourless transparent non-lead glass, coloured ground non-lead glass, blown with hot applications, 1967. Produced at the experimental workshop of ceramics and sculpture factory in Lviv. © Ensemble Kuskovo.
- 6 Boris Smirnov, sculpture, ‘Man, Horse, Dog and Bird’, colourless transparent non-lead glass, coloured ground and polished non-lead glass, blown with hot applications, before 1970. Produced at Leningrad Factory of Artistic Glass. © Corning Museum of Glass.
- 7 Table clock with chime, Vesna, 1963. Produced at Vladimir clock factory. © Azat Romanov Collection.
- 8 Wall clock, Iantar’, 1965. Produced at Orel clock factory. © Azat Romanov Collection.

- 
- 9 Radio receiver, Moskvich, 1963. Moscow aerophone factory.  
© Azat Romanov Collection.
  - 10 Vase, 'Narcissus', porcelain, colour monochrome glaze, shape by Anna Leporskaia, 1962. Produced at Leningrad Porcelain Factory.  
© The State Hermitage Museum.
  - 11 Buran vacuum cleaner, 1968. Produced at Elektromashina factory, Prokopievsk. © Museum of Moscow.
  - 12 Teapot, USSR, porcelain, 1970s. © Museum of Moscow.
  - 13 Olga Nekrasova-Karateeva, 'Calla Lilies', chamotte, salts, glazes, 1976. Produced at the workshop cooperative of decorative-applied art of the Leningrad branch of the RSFSR Art Fund. Photo by Mikhail Kopylkov. © Novaia Niva Publishers.
  - 14 Mikhail Kopylkov, 'Pink Dress and Autumn Coat', chamotte, salts, glazes, metal, 1976. Produced at Kipsala workshop, Dzintari. Photo by Mikhail Kopylkov. © Novaia Niva Publishers.
  - 15 Vladimir Tsivin, 'People and Objects', chamotte, engobe, glaze, metal, glass, 1980. Produced at the workshop cooperative of decorative-applied art of the Leningrad branch of the RSFSR Art Fund. Ensemble Kuskovo. Photo by Mikhail Kopylkov. © Novaia Niva Publishers.
  - 16 Olga Nekrasova-Karateeva, 'Self-Portrait', chamotte, enamels, glazes; potter A. Sokolov, 1984. Produced at the workshop cooperative of decorative-applied art of the Leningrad branch of the RSFSR Art Fund. Photo by Mikhail Kopylkov. © Novaia Niva Publishers.

# Figures

- |     |                                                                                                                                                                                                                                                             |    |
|-----|-------------------------------------------------------------------------------------------------------------------------------------------------------------------------------------------------------------------------------------------------------------|----|
| 1.1 | Pioneer café interior in the Pioneer Palace on the Lenin Hills, 1961. © Felix Novikov.                                                                                                                                                                      | 45 |
| 1.2 | Playroom for young children in the Pioneer Palace on the Lenin Hills, 1961. © Felix Novikov.                                                                                                                                                                | 46 |
| 1.3 | Kitchenware, before 1961. Produced at the factories Emal'posuda No. 2 and Krasnyi Vyborzhets, Leningrad oblast. © Dialogue of Arts journal.                                                                                                                 | 56 |
| 2.1 | Comparative analysis of British electric shaver the Milward Courier (left) and Soviet analogue Utro (right), 1965. VNIITE, RGANTD, f. R-688, op. 1–1, d. 57, l. 5. © Russian State Archive of Scientific and Technical Documentation.                       | 77 |
| 2.2 | Vsevolod Medvedev et al., project for an array of kitchenware and implements for a family of 3–4 people, 1966. LF VNIITE, TsGANTD SPb, f. R-146, op. 2–1, d. 77, l. 91. © Central State Archive of Scientific and Technical Documentation at St Petersburg. | 86 |
| 2.3 | Vsevolod Medvedev et al., technical drawing of aluminium kitchenware, 1966. LF VNIITE, TsGANTD SPb, f. R-146, op. 2–1, d. 77, l. 90. © Central State Archive of Scientific and Technical Documentation at St Petersburg.                                    | 87 |
| 3.1 | Leida Jurgen, water set, 'Strings', colourless lead glass, incising, 1962. Produced at Leningrad Factory of Artistic Glass. © Yelagin Palace Museum of Russian decorative and applied arts and interior of XVIII–XX centuries.                              | 97 |
| 3.2 | Boris Smirnov, vases, 'Glass Blowers', transparent lead glass, sandblasting, engraving; sandblasting by Helle Pyld and R. Antonenko, engraving by A. Soloviev, 1961–63. Produced                                                                            |    |

- 
- at Leningrad Factory of Artistic Glass. © Yelagin Palace Museum of Russian decorative and applied arts and interior of XVIII–XX centuries. 98
- 3.3 Iurii Biakov, ‘Troika’, colourless lead glass, sandblasting, depolishing, wood, 1968. Produced at Leningrad Factory of Artistic Glass. © Yelagin Palace Museum of Russian decorative and applied arts and interior of XVIII–XX centuries. 111
- 4.1 A. Kholodkov et al., model of alarm clock Vitiaz’ for Rostov clock factory, variant A, 1972. VNIITE, RGANTD, f. R-688, op. 4–1, d. 21. l. 7. © Russian State Archive of Scientific and Technical Documentation. 124
- 4.2 A. Kholodkov et al., model of alarm clock Vitiaz’ for Rostov clock factory, variant B, 1972. VNIITE, RGANTD, f. R-688, op. 4–1, d. 21. l. 10. © Russian State Archive of Scientific and Technical Documentation. 125
- 4.3 A. Kholodkov et al., model of alarm clock Vitiaz’ for Rostov clock factory, variant A, control panel, 1972. VNIITE, RGANTD, f. R-688, op. 4–1, d. 21, l. 9. © Russian State Archive of Scientific and Technical Documentation. 126
- 4.4 Vladimir Rezvin et al., model of the refrigerator OKA-USh with a capacity of 275 litres, interior view, 1974. VNIITE, RGANTD, f. R-688, op. 4–1, d. 52, l. 11. © Russian State Archive of Scientific and Technical Documentation. 131
- 4.5 Vladimir Rezvin et al., model of the refrigerator OKA-USh with a capacity of 275 litres, general view, 1974. VNIITE, RGANTD, f. R-688, op. 4–1, d. 52, l. 10. © Russian State Archive of Scientific and Technical Documentation. 132
- 4.6 Vladimir Rezvin et al., model of the refrigerator OKA-USh with a capacity of 350 litres, general view, 1974. VNIITE, RGANTD, f. R-688, op. 4–1, d. 52, l. 13. © Russian State Archive of Scientific and Technical Documentation. 133
- 4.7 B. Korolev et al., layout scheme of vacuum cleaner Buran 7, 1977. VNIITE, RGANTD, f. R-688, op. 4–1, d. 94, l. 15. © Russian State Archive of Scientific and Technical Documentation. 138
- 4.8 B. Korolev et al., model of vacuum cleaner Buran 7 with a set of nozzles, 1977. VNIITE, RGANTD, f. R-688, op. 4–1, d. 94, l. 28. © Russian State Archive of Scientific and Technical Documentation. 138
- 4.9 Dmitrii Kochugov et al., design programme Vtormar (‘Secondary material resources’), experimental implementation, 1984. LF VNIITE, TsGANTD SPb, f. R-146, op. 22, d.146, l. 74a. © Central State Archive of Scientific and Technical Documentation at St Petersburg. 152

- 5.1 Grigorii Kapelian, sketch of the poster for the 'One Composition' exhibition, 1977. © Novaia Niva Publishers. 188
- 5.2 Adolf Ostroumov, sculpture, 'Galatea', lead glass, sandblasting, 1977. © Yelagin Palace Museum of Russian decorative and applied arts and interior of XVIII–XX centuries, 2017. 192

## Acknowledgements

This book is about comradely objects – products envisioned by Soviet designers to make everyday life in the Soviet Union more convenient and joyful. The completion of this book owes a lot to the comradely relations – with my mentors, colleagues and friends – that I have been lucky to enjoy at every stage of research and writing. This project also greatly benefited from the support of different institutions. I express great gratitude to all of them.

The major part of this book project was funded by the European Union's Horizon 2020 research and innovation programme under the Marie Skłodowska-Curie grant agreement No. 700913. The early stages of my research were supported by the Central European University in Budapest, the Malevich Society and the German Historical Institute in Moscow. As a postdoctoral researcher at Aarhus University, I also benefited from the Aarhus University Research Foundation starting grant that allowed me and my colleagues to form a network of researchers on the interconnections of material culture and gender in Soviet and post-Soviet Russia.

My earliest inspiration in the history of Soviet objects came from the Alexander von Stieglitz Academy of Art and Design in St Petersburg, formerly a leading Soviet design school and the alma mater to many of the protagonists in this book. I thank Galina Gabriel and Tatiana Kovaleva, my professors from the Department of Art History, for showing me as a young undergraduate the many ways in which material objects influence our lives.

I would also like to express my gratitude to my mentors and colleagues in the Department of History at the Central European University in Budapest for all the encouragement they gave me in the earliest stages of my research. I thank my doctoral supervisor, Marsha Siefert, for her expert guidance, inspiring discussions and unending trust in this research project.

Others also provided me with much-needed wisdom on late Soviet aesthetics and material culture during this time. My external adviser, Serguei Oushakine, inspired me to be brave in posing theoretical questions and attentive to seemingly trivial historical sources. Susan Emily Reid, David Crowley, Karl Hall, Sampsa Kaataja, Irina Sandomirskaja and Ilya Kukulin also shared valuable advice that contributed to this book's inception.

The major part of this book project was completed at the School of Communication and Culture at Aarhus University, Denmark. I am indebted to my postdoctoral supervisor Jakob Ladegaard for his careful reading of several draft chapters, as well as his insightful commentaries and kind guidance to Danish academic life. I highly appreciate the support of my second postdoctoral supervisor, Birgitte Beck Pristed from the Department of Global Studies, for her continual encouragement. I also thank Birgitte and my colleague from Aalborg University, Olga Gurova, for their great help in organising the international conference 'The Body of Things: Gender, Design and Material Culture in (Post)Soviet Russia', Aarhus University, 8–9 March 2018. This conference brought together scholars from different disciplines and became a space for thriving intellectual exchange that was crucial in the final stages of my writing.

My postdoctoral research in Denmark greatly benefited from numerous visits to the Designmuseum Danmark and its library. I thank the librarians Anja Lollegaard and Sara Fruelund for their generous help with finding relevant theoretical literature and showing such great interest in my book. I am also grateful to Anders V. Munch and Hans-Christian Jensen from the University of Southern Denmark and to Kristian Handberg from Copenhagen University for kindly giving me the opportunity to give a public talk about Soviet design to a Danish audience.

Many colleagues from the fields of design history, art history, Russian and Soviet studies and others have supported my project in various ways – providing valuable feedback, suggesting secondary sources, and asking thought-provoking questions. My gratitude goes, in no particular order, to Kjetil Fallan, Grace Lees-Maffei, Tom Cubbin, Daria Bocharnikova, Angelina Lucento, Maria Silina, Iliana Veinberga, Anders Kurg, Mari Laanemets, Olga Kazakova, Xenia Vytuleva, Alexandra Sankova, Alyona Sokolnikova, Azat Romanov, Alexey Golubev, Anton Kotenko, Oleksandr Nadtocka, Ioana Macrea-Toma, Irina Denischenko, Bradley Gorski, Ekaterina Emeliantseva, Natalia Petrova, Olga Kazakova, Anton Sheverdiaev, Alexander Terebenin, Nikita Balagurov, Pavel Vasiliev, Dmitrii Kozlov and Anna Mazanik. Special thanks go to Julia Gusarova who on numerous occasions kindly shared unique and extremely valuable materials on late Soviet decorative art.

This book would not have been possible without the former participants in the Soviet design and decorative art communities who kindly agreed to answer my questions. I am immensely grateful to Vladimir Paperny, Vitaly Komar, Olga Nekrasova-Karateeva, Natalia Malevskaia-Malevich, Inna

---

Olevskaia, Mikhail Kos'kov, Larisa Romanova, Vasiliï Gusarov, Vladimir Tsivin and Mikhail Kopyl'kov.

I thank the two anonymous reviewers for their valuable comments on the first version of my manuscript. Emma Brennan and Alun Richards from Manchester University Press guided me through the publication process, and Reynolds Hahamovitch provided careful stylistic editing.

Finally, I am grateful to Ksenia, Evgeniya, Adela and Lars for their comradely support and to my parents for everything.

Parts of this book have previously appeared in the following publications: 'Accommodating "Design": Introducing the Western Concept into Soviet Art Theory in the 1950s–60s', *European Review of History – Revue européenne d'histoire* 20.4 (2013), 627–47; "'A Glass without Bottom": Neodecorativism in Soviet Applied Art in the Late 1960s', *Journal of Design History* 3.1 (2017), 1–15; 'Visions and Visualization of Sustainability: Leningrad Designers in Search of Nationwide Recycling System, 1981–84', in Aga Skrodzka, Xiaoning Lu and Katarzyna Marciniak (eds), *The Oxford Handbook of Communist Visual Cultures* (Oxford: Oxford University Press, 2019).



## Abbreviations and acronyms

KhKR	artistic-engineering elaboration
LF VNIITE	Leningrad branch of the All-Union Research Institute for Technical Aesthetics
LOSKh/LSSKh	Leningrad branch of the Artists' Union of the RSFSR
MOSKh	Moscow Branch of the Artists' Union of the RSFSR
MVKhPU	Moscow Higher School for Art and Industry (former Stroganov School)
RSFSR	Russian Soviet Federal Socialist Republic
Vkhutein	Higher Artistic-Technical Institute
Vkhutemas	Higher Artistic-Technical Workshop
VIVR	All-Union Institute for Secondary Resources
VLKSM/Komsomol	All-Union Lenin Communist Youth League
VNIKS	All-Union Research Institute for Studying the Population's Demand for Commodities and the State of Trade
VNIITE	All-Union Research Institute for Technical Aesthetics

## Note on transliteration and translation

This book uses the Library of Congress transliteration system, except for firmly established forms for specific names (Gorky, Groys, Lissitzky, Mayakovsky, Shklovsky and Ostrovsky). Unless otherwise indicated, the translation of all Russian quotations is my own.



## Introduction: Soviet things that talk

'A silent speech that things address to us every day in an artistic language is infinitely more convincing than dozens of lectures about aesthetic education, good taste, etc. To make this language of things contemporary and expressive is the exciting but difficult task of an artist.'<sup>1</sup> This was how the Soviet art critic Nina Iaglova opened her article in the journal *Decorative Art of the USSR* in June 1961. Here, 'things' (*veshchi*, material objects) appear as active participants in people's lives, as agents by virtue of being speakers. However, their 'speech' is possible only through the power of human agents – artists. Art infiltrates into everyday life through objects; objects affect everyday life through 'speech' composed by artists; artists educate society in aesthetics through objects.

The interplay between art and the quotidian, between people and objects, described by Iaglova, has also informed recent developments in the humanities and social sciences. The 'material-cultural turn' that emerged in the mid-1980s in archaeology and anthropology converged with critiques in other social sciences and humanities disciplines in the following decade.<sup>2</sup> In the late 1990s–2000s, this resulted in a flow of new theoretical streams that shifted scholars' focus from discourse to materiality and from human to non-human agents (described through 'bio-, eco-, geo-, neuro-, necro-, zoo- concepts', as historian Ewa Domanska summarises).<sup>3</sup> Actor-network theory, new materialism, object-oriented ontology, material feminisms, thing theory and other branches of critical theory offer different reconsiderations of the social and political role of objects. A growing body of scholarship in anthropology, archaeology, history, art history, science and technology studies, and across other disciplines, treats objects not as mere inert possessions or carriers of symbolic meaning, but rather as agents of social relations that communicate with people in various ways, not the least of which is sensory qualities.<sup>4</sup>

## Design history and the study of materialities

This non-anthropocentric, post-humanist paradigm offers new perspectives to scholars of design, as well as critical and methodological tools. Since the 1980s, and concurrently with the development of material culture studies, design historians have been increasingly critical of older interpretations that saw design as the elite activity of ‘geniuses’ which produces the sleek and evocative masterpieces that sit in museum displays. In his seminal book *Material Culture and Mass Consumption* (1987), the leading scholar of material culture studies, Daniel Miller, criticised design history as a ‘bizarre’ field of inquiry, ‘intended to be a form of pseudo art history, in which the task is to locate great individuals such as Raymond Loewy or Norman Bel Geddes and portray them as creators of modern mass culture’.<sup>5</sup> As Kjetil Fallan notes, design historians accepted this reproach and, moreover, found in it the inspiration to expand their research to consumer practices. The critique within the field of design history was developing at the same time. In her 1987 textbook, Hazel Conway criticised the so-called ‘heroic approach’ to design history, explaining to students that just as social historians inquire into the lives of various social strata and communities, design historians should do ‘more than the study of key figures and key objects’ and view design as ‘an activity within a social and material context’.<sup>6</sup> A decade later Judy Attfield, Miller’s student, dedicated a book to the ‘wild things’ of everyday life and called for a broadening of the meaning of design to include not just objects as ‘celebrities’, but also ‘that larger part of the designed object’s biography when it is no longer sacred, when it forms part of the disordered everyday clutter of the mundane, and joined the disarray of wild things that don’t quite fit anywhere – the undisciplined’.<sup>7</sup> Attfield’s call proved popular and by the end of the millennium everyday objects appeared central to the history of design.

Over the last two decades a significant number of monographs and articles written by design historians have explored not just everyday consumption, as Attfield proposed, but also intermediary stages between production and consumption: manufacture, marketing, distribution, retailing and reception.<sup>8</sup> This prompted the inclusion of various mediators such as ‘dealers, distributors, sales managers and product testers’ as agents of the design process. Many of these studies also demonstrate a sensitivity to the sensory qualities of objects,<sup>9</sup> and with the recent turn towards global and transnational design history, scholars have also incorporated the role of materiality in design and consumption outside of the Euro-Atlantic world.<sup>10</sup> Further, the recent interest in the environmental aspects of design and in sustainability as a part of design culture has prompted inquiry into the post-consumption life of objects, such as disposal, recycling and reuse.<sup>11</sup> Fallan argues that this latter trend in particular can benefit from new

materialist optics in reconsidering the history of interrelations between humans, objects and nature.<sup>12</sup>

This decentralisation of ‘heroic’ designers and increased attention to materiality provides broad opportunities for examining design under state socialism. While collectivist institutional culture and planned economies precluded designers from obtaining full-fledged individual recognition, let alone stardom, material culture and consumption continuously preoccupied the minds of state and Party authorities, experts of different profiles and ordinary people. However, state socialism not only provides fertile soil for ‘new materialist’ and ‘object-oriented’ design histories. It also offers a theoretical precedent: the concept of a ‘comradely object’. This idea developed within the Russian avant-garde of the 1920s and proved resilient, lasting well into the late Soviet period.

### Comradely objects and overlooked subjects

One branch of the Russian avant-garde in the early 1920s is known as ‘productive art’ (*proizvodstvennoe iskusstvo*) or ‘productivism’ (*proizvodstvennichestvo*). At its core was the repudiation of easel and figurative art and the critique of the elevated role of the artist as separate from industrial production. Artists such as Varvara Stepanova, Liubov Popova and Aleksandr Rodchenko, supported by such theorists as Boris Arvatov, Nikolai Tarabukin and Osip Brik, centred around the avant-garde journal *LEF* (*Left Front of Art*), put forward a vision of the artist as just one of many industrial workers involved in the making of an object. The productivists believed that organising the production process was a crucial task of an artist.<sup>13</sup> Another, no less important role was as a producer of useful objects for the masses rather than pure art for a select public. This vision radicalised the Arts and Crafts movement’s call for aestheticising labour by reconceptualising art as ‘intellectual-material production’,<sup>14</sup> and at the same time proposed an alternative to a capitalist commodity by promoting the self-conscious creation of objects for everyday consumption. In opposition to seductive commodities – or as Rodchenko called them, ‘dark slaves’ of the market<sup>15</sup> – the socialist object was to be modest and utilitarian, clearly manifesting the way it was produced, that is, the labour invested in it. According to productivist theorists and artists, the structural transparency of an object would eliminate commodity fetishism and stimulate rational and ‘comradely’ relations between people and objects. As Boris Arvatov argued in 1926,

The exposure of the methods of artistic skill, the liquidation of fetishist ‘mystery’, the transfer of these methods from the artist-producer to a consumer – this is the only condition for the disappearance of the age-old border separating art and practice. Artistic products, which exist within *byt* [everyday life] and develop together with it, thus cease to be distinguished from the rank of ‘unique objects’...<sup>16</sup>

In another article, Arvatov envisioned socialist objects of the future as dynamic things, similar to Western objects such as moving staircases and sliding doors in American public buildings, but integrated into the socialist economy and daily life. For Arvatov, the socialist object was to become ‘an instrument and a co-worker’.<sup>17</sup>

Christina Kiaer’s impressive study of the objects of Russian Constructivism (an avant-garde stream that included productivism) indicates that the idea of the ‘comradely object’ not only opposed the commodity culture of capitalist countries, but also responded to the partial revival of market mechanisms under the New Economic Policy (NEP), introduced by Lenin in 1921 as a temporary measure to develop the economic basis for a Soviet industry ravaged by the Civil War. As Kiaer suggests, NEP policies such as the legalisation of private wholesale and retail trade and private manufacturing ‘acknowledged that functioning systems of consumption were the necessary counterparts to modern systems of production, and that a path toward socialism that took consumption into account was more likely to succeed in the conditions that the Bolsheviks faced in 1921’. The ideological opposition to the NEP inspired the productivists to confront the problem of consumer desire with designs for everyday objects such as stoves, babies’ bottles or dresses that they viewed as capable of ‘fulfilling or amplifying the sensory capacities of the human organism’.<sup>18</sup> The curtailment of the NEP in the latter half of the 1920s and the launch of a full-scale industrialisation campaign was followed by the restriction of such cultural policies and a ban on independent artistic movements, so these comradely objects did not reach a mass audience through mass production as the productivists had planned.

However, what happened to productivism after Stalin’s death? In the late 1950s Soviet cultural policies softened and opened, though only moderately, to international influences, and the state proclaimed a new dedication to improving living standards. My hypothesis is that these changes allowed for the resurrection of the theoretical foundations of productivism and the revitalisation and spread of those design philosophies into the socialist material culture and everyday life of Soviet Russia. I will demonstrate how the objects designed in the late socialist period – from dinnerware to vacuum cleaners – echoed the avant-gardist dream of a well-organised and socially impactful material culture.

This book, therefore, examines the second historical attempt to create comradely socialist objects, instituted as a response to burgeoning Western consumer culture that was being used as a tool of soft power in the cultural Cold War.<sup>19</sup> Methodologically, I combine the insights of new materialism and recent design histories with the theoretical framework of Soviet productivism. In addition, I engage with an idea from Russian avant-garde’s literary theory, the ‘biography of the object’, which Serguei Oushakine reads as one of the precursors to new materialist thinking.<sup>20</sup> In his 1929

essay, the critic Sergei Tretiakov coined the term ‘biography of an object’ as an innovative method for creating a literary plot. Tretiakov argued that an object passing through a range of people acts as a measure of collective emotions and the dynamics of social relations.<sup>21</sup> ‘Object biographies’ resurfaced in the 1980s’ ‘material-cultural turn’<sup>22</sup> and inspired an interest in everyday things in a new cohort of design historians such as Attfield.

However, despite drawing on Tretiakov’s concept, it is beyond my capacity to follow all the stages of the biographies of late Soviet objects. The history of consumption and daily life under state socialism is a burgeoning field of inquiry with contributions from historians and anthropologists.<sup>23</sup> However, few studies consider the materiality of objects and the interrelation between design, production, mediation and consumption.<sup>24</sup> This would be a challenging task, because recurrent problems in the Soviet planned economy – such as quantitative indicators of performance, poor supply of raw materials, and lack of coordination between industry and retail trade – precluded the smooth implementation of designs into consumption. This contrasted with the situation in East Germany, where designers were moderately successful in getting their projects implemented and so as to reach people’s homes, as Katharina Pfützner indicates in her recent book.<sup>25</sup> Accordingly, the scholarship on socialist design, since it began in the late 1990s, has focused on normative statements by artists, designers, architects and critics concerning what makes good taste, and how this was disseminated through mass media and exhibitions in museums and galleries and at national and world fairs. Though identifying a range of complex issues, these studies mostly provide a narrative of a state-sponsored drive towards functionalism and against ‘petty-bourgeois’ tastes and ‘excessive’ decoration.<sup>26</sup> These studies have mostly focused on the period of Nikita Khrushchev’s leadership, when the Soviet Union positioned itself as a modern state *inter pares*, encouraged the development of certain modernist trends in art and architecture, and recognised design as a full-fledged profession. As Susan E. Reid aptly summarises, ‘the Khrushchev era represented a great but uneven leap forward in creating the basis for a modern way of everyday life and a radical stylistic reorientation in domestic spaces and the visual appearance of cities towards a new aesthetic of socialist modernism’.<sup>27</sup>

From the second half of the 2000s, a younger generation of scholars has been complementing and expanding the narrative of the ‘Khrushchev modern’, often tracing design developments after the early 1960s. They have explored the tensions within design reformism, identified earlier by Reid: tensions between artistic individuality and mass production, between folk traditions and advanced industry, and between professionals’ critical thinking and the necessity to fulfil Party guidelines.<sup>28</sup> My book contributes to this body of scholarship by examining the dynamic relations between objects and those human subjects, who have not received nearly as much



attention as Western ‘celebrity’ designers. Soviet designers worked as collectives and representatives of institutions, sectors, bureaus and factories – a system that the director of the Moscow Design Museum, Alexandra Sankova, considers to be a historical injustice.<sup>29</sup> Anonymity was typical of industrial designers under state socialism. The names of decorative artists were usually known from exhibitions, but the marginal status of these artists in Soviet artistic communities diminished their social outreach and fame.

My intention, however, is not to ‘restore justice’ through a ‘heroic’ approach to Soviet design by finding some unrecognised Soviet Raymond Loewy. Rather, I speak to the ongoing scholarly discussion concerning the position of professionals under state socialism and contest the dual image of them as either repressed, innocent intellectuals (a label usually applied to avant-garde artists)<sup>30</sup> or as opportunistic collaborators with the regime.<sup>31</sup> A number of recent studies provide a more balanced view, presenting professionals’ diverse strategies for navigating Soviet institutions and ideological guidelines, and creating spaces for debate and critique within the official culture.<sup>32</sup> Likewise, I argue that Soviet artists, designers and critics could be dedicated to the improvement of people’s everyday lives while also seeking opportunities for professional recognition, or could adopt certain forms of institutional critique without becoming dissidents. My desire to provide a nuanced picture of people who cared about household objects in difficult political circumstances is precisely what drives the inclusion of both human and inanimate agents in this analysis.

The discrepancy between the designers’ visions of highly functional, rational objects and the shabby, monotonous pool of available commodities has become a commonplace element of studies of Soviet design. Looking at alternative design communities, not directly related to economic guidelines, appears to be a more rewarding task than venturing into the routine of designing household objects. Tom Cubbin’s recent book explores precisely such an alternative community – the Senezh Experimental Studio, which was affiliated with the Artists’ Union of the USSR but whose members were critical of institutional Soviet culture and expressed alternative visions of socialist everyday culture through their conceptual work in interior, exhibition and graphic design.<sup>33</sup> My book examines the heterogeneity of Soviet design from a different perspective: the contesting ideas of objects, their uses, their social roles and their power to transmit messages from designers to consumers – or the power to subvert these messages. Tracing the implementation of this vision in production, retail trade, mass media and consumption is a task that would require extensive archival and oral history research in multiple geographical locations: the concentration of certain industries in specific Soviet regions meant that objects had to travel long distances before reaching consumers, if they ever did. An added complication is that factory

archives rarely preserve records of the production of specific prototypes. The full story of the production of late Soviet objects requires the inclusion of those who gained even less recognition than designers: engineers, technical workers and craftspeople of different backgrounds. This book, therefore, can be taken as the beginning of a longer story, outlining how everyday objects were conceived and presented in institutional reports, in the press and at exhibitions.

### Terminological challenges

As is well known, the term *design* is broad: it may mean anything from decorative work to form-giving in mass production to the many ways of finding optimal solutions to complex problems in the information age.<sup>34</sup> The concept of the object, on which this book is centred, highlights the material aspect of design across modes of production: different industries, semi-mechanised manufacture and handicrafts. Accordingly, 'design' is understood here not as a 'universal project-oriented activity'<sup>35</sup> but, instead, in the materialist sense proposed by Judy Attfield: as 'just one aspect of material culture of everyday life'.<sup>36</sup> Yet, as I have explained, unlike Attfield's inquiry into the post-production stages of the life of objects, I focus on pre-production and production stages of objects, including other material structures such as interiors or complexes of objects (so-called 'design programmes').

My preference in referring to the *object* over the *thing* as the central concept of this book derives from the new materialist distinction between two concepts that have a long tradition, beginning with Heidegger. In short, things are often presented as 'larger' than objects, as material entities irreducible to their functioning in human everyday life. Since my book focuses on design professionals' ideas concerning the material culture of daily life, *object* is a more appropriate operative term. However, I use the term 'things' when I need to emphasise the limits of designers' intentions to rationalise consumption and everyday life. This distinction is helpful in analysing Soviet professional discourse, which was based on an ambiguous vocabulary. Soviet design professionals usually used the term *veshch* (pl. *veshchi*), which can be translated both as 'object' and 'thing' (the latter can be used similarly in an abstract, non-material sense). Another popular and similarly ambivalent term was *predmet*, which means object, but can also be used in the sense of 'subject', like 'the subject of conversation'. My aim is to identify and characterise the gradations of meaning behind either usage among Soviet designers. For example, in the quote opening this introduction, critic Nina Iaglova acknowledges the possibility that objects might have a message larger than the designers' intention and that artists may act as interpreters rather than masters and creators of *veshchi*. The interplay between the two meanings of *veshch* is perhaps the most

interesting aspect of the second historical attempt to create a socialist material culture that commenced in the 1960s.

In addition to a professional design vocabulary, Soviet material culture was affected by economic categories. Household objects, together with sports equipment, musical instruments and other accessories for leisure activities, constituted the category *tovary kul'turno-bytovogo naznacheniiia* (commodities of cultural and everyday purpose), which was a subcategory of *tovary shirokogo potrebleniia* (consumer goods or commodities). However, this terminology appeared in design professionals' parlance rather infrequently, usually when they discussed retail trade and consumption, the desired targets of their work. For analytical purposes, I use the terms 'commodity' and 'consumer goods', but they do not apply to the entire area of professional activity considered in this book. My focus is on the different attempts to address the problematic nature of commodity culture in socialist society and to create non-capitalist commodities, or even non-commodities.

A late Soviet object could not entirely belong to commodity culture. This was not only because of its subjection to the planned economy, but also because of its proximity to the category of art. The complex interrelations between art, design and production is a crucial theme of this book. It poses another terminological challenge: finding a vocabulary for artists' efforts to create a world of comradely objects. The terms *decorative art* (*dekorativnoe iskusstvo*) and *applied art* (*prikladnoe iskusstvo*) became popular in Russia from the mid-nineteenth century under the influence of the European, primarily British, movement for art reform, prompted by rapid industrialisation and mass production. In Russia, both terms were associated with the decoration of objects mass-produced for utilitarian use and, more broadly, with the establishment of art and industry schools and the reorganisation of peasant craftsmen into cooperative handicraft workshops beginning in the 1860s, a process that reached its peak at the turn of the century.<sup>37</sup> In the education of decorative and applied artists, the main emphasis was placed on the meticulous study of traditional Russian and European ornaments, understood as decisive stylistic elements. The promotion of artisanal industry also played a role in popularising traditional ornaments. The leftist artists of early Bolshevik Russia, especially productivists, dismissed this approach as backward and described it pejoratively as *prikladnichestvo* ('corny craft') and *ukrashatel'stvo* ('kitsch decoration'). After the reform of artistic organisations in the early 1930s, accompanied by the condemnation of avant-garde movements as 'bourgeois', the terms *dekorativnoe iskusstvo* and *prikladnoe iskusstvo* were used more frequently, but usually to describe minor forms of art, secondary to painting and sculpture. At the same time the Soviet artisanal industry was instrumentalised for souvenir production and to showcase the diversity of traditional crafts in the Soviet republics.<sup>38</sup>

After Stalin's death, art professionals had to modernise this terminology. Aleksandr Saltykov, an expert on Russian religious art and peasant crafts, popularised the somewhat cumbersome term *decorative-applied art* to signify the art of organising everyday life. The term appeared in official names of specialised departments in artists' unions and sections of exhibitions and became part of the official terminology. However, not all of Saltykov's colleagues were satisfied with the term, and theoretical objections and corrections were continually expressed. Many thought that *applied* should instead signify the superficial application of decoration to poorly made utilitarian objects. *Decorative art*, though not totally satisfactory, caused fewer objections.

Drawing the line between 'decorative art' and 'design' is not always easy for a historian of state socialism, and neither was it for the protagonists of my story. Therefore, the choice of term is conditional in every instance. When speaking about the projects of the main Soviet design organisation, the All-Union Research Institute of Technical Aesthetics (VNIITE), I use 'design' as a shortcut for 'industrial design' – the activity concerned with the visual coherence, functionality, economic feasibility and user-friendliness of industrially produced objects. In the chapters dedicated to the artistic work on limited-edition or unique objects in traditional materials (e.g. ceramics, glass, textiles), I find *decorative art* to be the most succinct term, not least because my protagonists chose it as a compromise in terminological battles. In general discussions, I use the term 'design' with what Glenn Adamson et al. call an 'ecumenical attitude'<sup>39</sup> – that is, inclusively. I understand design as the creative work aimed at producing various objects. This choice of terminology is, I believe, the most useful in a book centred on the biography of objects across different professional settings before the consumer stage (which, in many cases, never occurred). In accordance with this choice, the umbrella term 'design professionals' will appear throughout the chapters to include decorative artists, designers and critics.

## A historical overview of Soviet design

The 1920s productivist vision of the artist as a producer of 'comradely' objects waned and eventually dissipated with the state's campaign for centralising art policies in the early 1930s. This period was marked by rapid industrialisation and mass mobilisation. The Soviet state promoted modest luxury objects as the reward for the hard work of outstanding workers, technical specialists and engineers; these objects were often decorated with conventional ornaments.<sup>40</sup> Beginning in 1932, with the (in) famous resolution by the Central Committee of the Communist Party 'On the reconstruction of literary and artistic organisations' (23 April 1932),<sup>41</sup> the avant-gardist idea of the artist as an organiser of life gave way to the

view of the artist as a collaborator with power, obedient to the tastes of the Party leaders. Visual artists were now expected to celebrate the Soviet 'bright future' in paintings, sculpture, graphic arts, monumental art (frescoes, mosaics or tapestries), and by decorating public interiors, city squares, parades and festivals. In the field of transportation and military hardware design, specialists responsible for the appearance of items and how this connoted their practical function were not called 'designers' but 'constructors' (*konstruktory*).<sup>42</sup> Their activity was perceived as purely technical and not aesthetic; the predominant criteria for their designs were practicality, durability and economic considerations.<sup>43</sup> The sole Soviet art journal *Iskusstvo* did not pay attention to their work, as its editors did not even regard it as related to aesthetics.

This did not mean the end of design, however. After 1932, many of the survivors of the avant-garde movement found refuge in set design, book illustration, clothing design and organising public celebrations. Soviet industrialisation and the thriving of transport engineering created a need for designers of vehicle interiors – ships, boats, aeroplanes, trams – many of whom came from architectural backgrounds. For example, the architect Iosif Vaks, an employee of the Leningrad Research and Project Institute of House Building and Civil Engineering (Lenproekt) in the 1940s–1950s, designed interiors for a number of passenger ferries and a tram car manufactured by the Leningrad car-repair plant.<sup>44</sup> Engineering and decorative art had little in common at that time: the former was oriented to solving utilitarian tasks, the latter to creating new socialist 'beauty'.<sup>45</sup> No systematic guidelines for creating different types of material objects existed at that time.<sup>46</sup>

However, the first steps towards establishing a design profession in the USSR were made in the midst of the Second World War in the besieged city of Leningrad: Vaks, then a camouflage-maker for the air division of the Baltic Fleet, recognised the need to train specialists for the restoration of damaged monuments and buildings after the war's end. In October 1943, with the support of the chief architect of Leningrad, Nikolai Baranov, Vaks obtained permission from the executive committee (Ispolkom) of the Leningrad Soviet of workers' deputies to establish a school of art and industry, based on the model of the Central School of Technical Drawing, which had been liquidated in 1922.<sup>47</sup> The LKhU (Leningrad Art School) officially opened, with the sanction of the Council of People's Commissars of RSFSR, on 1 January 1944 (a year after the siege had been partially broken).<sup>48</sup> It was staffed by pre-war graduates from the Ilya Repin Institute<sup>49</sup> and the School of Technical Drawing, who had survived the war and whom Vaks summoned from the far-flung destinations they had previously been evacuated to. Notably, the enrolment provided students – 15–18-year-olds who had earlier been evacuated from Leningrad and had now returned to be trained as restorers – with access to free housing, basic clothing and free meals, a real privilege in an exhausted city during wartime.<sup>50</sup>

The next step in making design a profession in the USSR was the governmental resolution ‘On preparing cadres for art industry and art-decorative works’ in February 1945. This document sanctioned the development of LKhU into a larger institution, the Art and Industry School, named after Vera I. Mukhina (known as the Mukhina School for short), which together with the Moscow Art and Industry School (a revived pre-revolutionary Count Stroganov School of arts and crafts) became the very best of Soviet design education and guided the thirty art-and-industry vocational schools nationwide, with a total of 3,140 students.<sup>51</sup> A parallel development occurred in engineering design, under the guidance of Iurii Soloviev, a son of an aircraft factory director who, thanks to his privileged social position, could influence the decisions of government officials.<sup>52</sup> As a graduate of the Moscow Printing Institute in 1943, Soloviev created and headed the Architecture and Art Bureau under the aegis of the Ministry of Transport Industry in December 1945.<sup>53</sup> The Bureau was responsible for designing public transport including river boats, railway carriages, Moscow trolley buses and, most prominently, the atomic-powered ice-breaker ship *Lenin* (designed in 1953–55).<sup>54</sup>

Meanwhile, some restructuring occurred within the Moscow and Leningrad Unions of Soviet Artists (MOSKh and LSSKh). The sector of decorative-ornamental art in MOSKh was renamed the ‘section of decorative-applied art’ and divided into three sub-sections: decorative-ornamental works, textiles and applied art.<sup>55</sup> This section, like its counterpart in Leningrad, became a centre for vibrant discussion on the social significance of form-giving to useful objects. In early 1953, and increasingly after Stalin’s death, when the ideological grip on artistic communities loosened, applied artists argued that their art was as important as painting and sculpture, if not more so. The latter affected Soviet people only in museums and public spaces, they argued, while ‘decorative-applied art’ permeates everyday life.<sup>56</sup> Such statements resonated with the state leadership, which had already realised in the early 1950s that the improvement of living standards and consumer goods could be an effective instrument for maintaining the public’s loyalty and the Soviet Union’s positive image vis-à-vis the capitalist West.<sup>57</sup> In October 1952 the XIXth Communist Party Congress outlined directives for the fifth Five-Year Plan, including a large-scale expansion of the state’s housing construction programme.<sup>58</sup> The new Party regulations, adopted at the Congress, guaranteed to satisfy ‘the constantly growing material and cultural demands of the Soviet People’,<sup>59</sup> a promise that necessitated intensive investment in the development of decorative art.

A crucial intersection between the interests of the state and of applied artists was mass housing. The post-war Soviet Union experienced a catastrophic shortage of living space, with barracks and communal flats as standard homes for a large majority of urban dwellers. A new housing

programme had already been developed by the Stalinist leadership, and between 1944 and 1954 some measures were taken. In November 1955 the Party and government issued a resolution 'On the liquidation of excesses in planning and building'<sup>60</sup> that called for the development of uniform housing complexes, the rational use of materials, and that rejected façade and interior decoration in favour of simplicity and economic feasibility. Later the housing decree of 31 July 1957 recognised the right to housing of all Soviet citizens and promised to overcome the housing shortage within 10–12 years. By then every Soviet citizen was to be provided with a separate, though small, flat.<sup>61</sup> People were gradually moving into their new flats and needed to turn them into homes, to furnish them with appropriate commodities, and the state needed experts to control and guide the new inhabitants.

Khrushchev's famous secret speech at the XXth Congress of the Communist Party in February 1956 greatly affected the development of Soviet design. However incomplete the process was, the de-Stalinisation that followed stimulated the liberalisation of culture and provided opportunities for rethinking Soviet aesthetics. There were two directions: learning from contemporary Western experience and a cautious revival of the ideas of the Russian avant-garde, including productivist art. A key event for the generation of professional design discussions was the First All-Union Convention of Artists, which took place in Moscow from 28 February to 5 March 1957.<sup>62</sup> This Convention not only completed the process of organising the Artists' Union of the USSR. It also responded to the vocal appearance of decorative art professionals by granting them representation on the Secretariat of the new Union's governing board, sanctioning the establishment of 'committees on decorative art'<sup>63</sup> on the governing boards of the Artists' Union of the USSR and the Art Fund (the social organisation that managed state commissions from artists), and founding an unprecedented monthly journal, *Dekorativnoe Iskusstvo SSSR (Decorative Art of the USSR)*. This journal would become a forum for debates on aesthetics, society and culture in Soviet society virtually until the end of the Soviet Union.<sup>64</sup>

The themes covered by the new journal grew to include the aesthetics of machines and appliances at the same time as the USSR was famously hosting the US national exhibition in the midsummer of 1959. This exhibition familiarised a broad stratum of Soviet society – not just the attendees but all those who followed the press coverage – with the appealing image of Western consumer culture. This momentous event has been described in detail by several historians, particularly emphasising the famous 'kitchen debate' between Khrushchev and the American Vice-President Richard Nixon. The debate made obvious the significance of domestic consumption as a component of political power.<sup>65</sup>

By the end of the 1950s several factors had come together for the emergence of the design profession in the USSR. First, Soviet trade organ-

isations, which provided commodities for export, showed an interest in the commodity culture of western Europe, especially Britain. Second, factory managers were interested in increasing labour efficiency.<sup>66</sup> Third, Iurii Soloviev strove to achieve the recognition and nationwide use of the methods that he practised in his Bureau. At the beginning of 1961 in the wake of the Soviet–British exchange of trade fairs, which included the showcasing of consumer goods, Soloviev travelled to England to learn from British design ideas and practical approaches to industrial design.<sup>67</sup> Upon his return, he managed to convince the stubborn Soviet authorities that industrial design was worth funding as ‘a powerful tool to improve the standard of living without substantial investment’, stressing its utilitarian aspect.<sup>68</sup> The confluence between the interests of applied artists, engineers, factory managers, trade workers and state leaders resulted in the governmental decree ‘On perfection of the products of machine-building industry and commodities of everyday purpose by the means of implementing methods of artistic engineering’ in April 1962.<sup>69</sup> Prepared by the State Committee on Science and Technology and formulated mostly by Soloviev, this document sanctioned the establishment of the All-Union Research Institute of Technical Aesthetics (VNIITE), a socialist counterpart to the UK Council of Industrial Design (CoID, est. 1945), with whose work Soloviev was familiar. Not surprisingly, Soloviev became the institute’s director (and retained this position until his emigration to England in 1991). The major aim of VNIITE was to develop a comprehensive theory of Soviet design and to establish design guidelines for prototypes for capital and consumer goods, as well as industrial graphics and corporate identity nationwide.<sup>70</sup> The decree authorised the establishment of design bureaus at major factories and regional economic councils and obliged all factories to have an ‘artist-engineer’ (*khudozhnik-konstruktor*) on the staff. The latter term was used instead of the Anglophone and then-considered capitalist term ‘designer’, while the term ‘design’ was considered too vague and was thus replaced by three different terms (these will be explained in [Chapter 2](#)). By the end of the 1960s VNIITE had ten regional branches in Leningrad, Sverdlovsk (now Yekaterinburg), Khabarovsk, Kiev, Kharkov, Minsk, Vilnius, Tbilisi, Yerevan and Baku.<sup>71</sup>

From the start, VNIITE actively strove to build an international network. Its monthly bulletin *Tekhnicheskaiia Estetika*, which first appeared in January 1964, regularly featured articles from Western design journals, and each issue was appended with an English summary. Acting as a skilled design diplomat, Soloviev consistently convinced the Soviet authorities to grant his employees access to foreign literature, research trips to the Eastern bloc countries and even, albeit less frequently, to the West. He also secured permission to host foreign designers, including such stars as Raymond Loewy and Kenji Ekuan, and to hold regular design exhibitions in the USSR.<sup>72</sup> From 1965 VNIITE was a member of the International



Council of the Societies of Industrial Design (ICSID) and participated in its annual congresses. In 1969 Soloviev was elected vice-president, along with such outstanding designers as Eliot Noyes and Gino Valle.<sup>73</sup> In this capacity, Soloviev organised an international design seminar, 'Interdesign', approved by both the ICSID and the Soviet government, which was held in Minsk, Belarusian SSR, and became an annual event.<sup>74</sup> In October 1975 Moscow hosted the 9th ICSID Congress.<sup>75</sup> In 1987, after years of negotiation, Soloviev convinced the government to authorise the establishment of the Designers' Union of the USSR.<sup>76</sup>

Another major institution related to the design of objects was the Artists' Union of the USSR. Through its regional branches and its Art Fund and through a complex system of workshop cooperatives, artists' retreats and exhibitions, the Artists' Union nurtured a vision of design as aesthetic and artistic, rather than just technical and economic. Even though the administrators of art institutions expected decorative art to act as an aid to traditional artistic industries such as textiles, porcelain, glassware, etc., they continually encouraged decorative artists to participate in general art exhibitions, thus placing their work in the category of visual culture.<sup>77</sup> Moreover, the label 'decorative art' often functioned as a pass for unconventional formal experiments. Decorative artists had more space for expression than their 'easel' colleagues. For example, the textile artist Anna Andreeva recalled working on state commissions for festivals and international exhibitions, where she was granted more freedom than easel painters, muralists and graphic artists. The marginal status of a decorative artist allowed Andreeva to experiment with techniques (such as *trompe-l'œil*) and motifs (such as Latin fonts) that would be unthinkable in 'big' art. As Ksenia Guseva notes, such 'visual experiments would have been impossible if not protected by the very logic of the textile media'.<sup>78</sup> Likewise, glass and ceramic art became leading arenas for daring compositions and imagery in the late 1960s and 1970s respectively, thanks to the 'protection' of the media.<sup>79</sup> Materiality, therefore, was the prerequisite for aesthetic breakthroughs. In addition, like VNIITE, the Artists' Union sponsored interregional and international exchange in the form of exhibitions, symposia, workshops and field trips, all of which stimulated a free flow of ideas that could otherwise prove challenging even in the seemingly safer waters of decorative art.

With all the differences between VNIITE and the Artists' Union in terms of principles, goals and approaches to managing Soviet socio-economic and cultural life, the two were interconnected through their personnel and agenda. Both, though to different extents, addressed the problem of educating the tastes of the Soviet people while also fulfilling their desires as consumers. In the time of Khrushchev's Thaw, both dealt with the organisation of labour and leisure of a society still overcoming the traumas of Stalinism and the Second World War. VNIITE and the decorative-applied art sections

of the Artists' Union played an important part in the post-Stalinist renegotiation of aesthetics and politics (this process may be compared to the efforts of the employees of the famous Ulm School of Design in West Germany to aid in the de-Nazification of culture, as Paul Betts demonstrates).<sup>80</sup> While Soviet design, broadly conceived, included a large number of organisations and institutions at different levels, my book focuses on these two as key players in conceptualising late socialist material culture, which created a space for the breaching of ideology and a debate about what constitutes properly socialist comradesly objects.

### The geographical challenge

The geographical scope of this study is confined to Soviet Russia to avoid generalisations about the many different republics and regions of the USSR. Even though the design system, like all Soviet institutional structures, was centralised, design developed differently according to each republic's economic situation, local public attitudes to art and craft traditions, and the use (or invention) of these traditions by state-employed specialists.

Needless to say, there was also a great diversity of design and material cultures within Soviet Russia. Regional and local histories of the Soviet era have become an important trend in scholarship, and a case study can reveal striking aspects of Soviet history that are not evident in those studies that only focus on Moscow or Leningrad. Recording the design histories of different Russian regions is a much-needed enterprise. However, arguably, such an enterprise would benefit from building on a general history of theories of objects, and the principles of design that in the Soviet case often started from the centre, and demonstrating how these authoritative guidelines were challenged or influenced by local initiatives. My aim is to provide the basis for such case studies by telling a story based on centrally issued documents and professional periodicals and by exploring the influential art/design collectives based in the two cities that concentrated a lot of creative forces – Moscow and Leningrad. Alternative geographies of Soviet design and material culture that would dispute this book's theses will be extremely valuable for studies of late socialism as well as for the general discussion of the global vs. the local in the history of design.

### Chapter outlines

The chapters proceed in a non-linear chronology. They trace the entangled development of the two professional spheres concerned with objects: industrial design and decorative art. [Chapter 1](#) expands on the historical background of socialist objects sketched briefly in this introduction. It introduces the concept of the *aesthetic turn* to describe the gradual

broadening of the meaning of aesthetics after Stalin's death in 1953, which culminated in the early 1960s. The aesthetic turn resulted in the formation in the USSR of what the philosopher Jacques Rancière calls an 'aesthetic regime of arts' – a mode of identifying different arts as equal and valuable in their specificity. I will analyse the new aesthetic regime of arts by highlighting its key categories: realism, contemporaneity and taste. These categories acquired new meanings during the 1950s and early 1960s. Realism was then seen as a specific quality of things, not as a way of depicting them. Contemporaneity appeared as a measure of the social relevance of an object. Finally, taste turned into a tool for probing the limits between authenticity and appearance. The chapter draws on professional discussions and designs from the 1950s–1960s to illustrate the new roles of these three categories.

The promise of the Soviet Communist Party and the government to 'fully satisfy the constantly growing material and cultural demands of the Soviet people' was central to the socio-political reformism of Stalin's successor, Nikita Khrushchev. It meant the mobilisation of various specialists in the campaign to increase the quality and quantity of available consumer goods and create a strong alternative to Western consumer culture. While historians have thoroughly explored the role of consumer goods' design during the Cold War, I will focus, in [Chapter 2](#), on the designers' approach to the existing pool of Soviet goods as unruly things that needed to be ordered into rational and well-functioning objects. The chapter will demonstrate how the professional debate regarding the borders between art, technics and everyday life paved the way for theorising industrial design under state socialism while some of its complexities became rapidly outdated with the institutionalisation of the design profession by the government. The chapter further analyses the methodology of VNIITE at the initial stage of its operation and thereby addresses the contradictions of the Khrushchev-era vision of the perfect order of things.

From the early 1950s Soviet decorative artists used their connection to everyday life as the main argument for their highly important status in the Soviet artistic community. The establishment of VNIITE in 1962 seemed like the beginning of a system of clear principles and guidelines for all types of objects and for the many different professionals who helped produce them. Decorative artists and designers all assumed the role of experts in improving material culture and particularly the modern home. This was the apogee of the Khrushchev-era aesthetic turn. However, as recent studies have shown, beginning in around 1965 with the removal of Khrushchev from power, the state and the experts that it employed changed their rhetoric from the praise of standard interiors and rational objects towards the permitting of a diversity of tastes and spirituality as an essential component of daily life. [Chapter 3](#) analyses the mid-1960s' conceptual change in decorative art and argues that it stemmed not only

from the official backlash against Khrushchev's reformist policies, but also from the Soviet designers' responsiveness to the global crisis of modernist aesthetics in the mid-1960s and the rise of the postmodernist critique of design. Comparing works of decorative art from the early and the late 1960s, the chapter reveals the techniques that the artists used in order to criticise the state-sponsored campaign for improving consumer culture. Far from an instrument of state propaganda regarding material well-being under socialism, Soviet decorative art in the late 1960s became a forum for commentary on the fundamental challenges of Soviet modernity. It raised such questions as the place of individuality in the world of uniform mass production and consumption, the fate of traditional crafts in the industrial age, the role of diverse folk motifs in Soviet cultural internationalism and the meaning of sincerity and emotional connection in a socialist society.

Meanwhile, the vision of a socialist object, promoted by VNIITE, was also far from uniform. [Chapter 4](#) identifies the elements of critique in state-sponsored industrial design of the 1970s. It shows that just as VNIITE designers had built a theoretical basis for action by the late 1960s and started developing new prototypes for modern domestic objects, such as vacuum cleaners and refrigerators, they also started to recognise the inadequacy of the object as a basic unit of socialist material culture. Following the theorists of the Ulm School of Design (1953–68) who were critical of American styling and promoted an interdisciplinary approach to design, VNIITE designers tended to see environments, and not objects, as ideal end products of their work. Without abandoning the avant-gardist idea of a comradely object, Soviet designers and theorists dwelled upon another notion of the avant-garde from the late 1960s: the artist as an organiser of all aspects of society's life, including the material environments of work and leisure. After discussing several projects for home appliances from the early 1970s, the chapter explains the notion of a design programme that answered to the interests of both the state and designers regarding the optimisation of life in late Soviet society. Through a case study of an early 1980s design programme, I will demonstrate that this type of designing was at once totalistic and flexible: it tended to regulate broad areas of human activity but also left space for consumer activity and variation.

Finally, the fifth chapter considers the identity crisis of the 1970s–early 1980s, experienced by decorative artists in the system of traditional art industries, state-sponsored workshops and exhibitions. It shows the joint attempt of artists and critics to renegotiate the position of decorative art vis-à-vis industrial design, industrial production and easel art. The proposed solution – the creation of a vigorous interdisciplinary production culture based on mutual respect between artists, engineers, technicians and administrators – proved insufficient to satisfy the decorative artists' creative and critical urges. Even factory-employed artists tended to dissociate themselves from the state-run campaign to improve consumer

products and life standards, instead focusing on consumers' 'spiritual needs'. While this tendency was connected to the rise of neo-traditionalist ideas and anti-Western attitudes among Soviet intellectuals, it was ideologically heterogeneous and was comprised of very different positions and motives. Ceramics came to be the leading arena for the seeking of a non-commodity-based material culture. I follow this role of ceramics through the decade-long activities of a group of Leningrad ceramic artists called One Composition (OK). Founded thanks to favourable institutional circumstances, the group reconsidered what constituted a useful object and questioned the role of decorative artists in a socialist society. Uncomfortable with their position as producers only of utilitarian objects, they advanced the concept of 'image-ceramics'. Limited by modest technical capabilities, the Leningraders tried to achieve the kind of expressive power usually associated with easel art. Though they focused on the symbolic meanings of objects, materiality instantly fascinated and informed them. The internal dynamics of the OK group reflected the tensions between Soviet intellectuals and the state in the early days of political and economic change under the leadership of Mikhail Gorbachev, known as *perestroika*, which would ultimately lead to the disintegration of the Soviet art and design system.

## Notes

- 1 N. Iaglova, 'Boris Smirnov – khudozhnik promyshlennosti', *Dekorativnoe Iskusstvo SSSR* 6 (1961), 11–15.
- 2 Dan Hicks, 'The Material-Cultural Turn', in Mary C. Beaudry and Dan Hicks (eds), *The Oxford Handbook of Material Culture Studies* (Oxford: Oxford University Press, 2010), pp. 25–98.
- 3 Ewa Domanska, 'Ecological Humanities', presentation for the keynote talk at the conference 'All Things Living and Not: An Interdisciplinary Conference on Post-Anthropocentric Perspectives in Slavic Studies', The Harriman Institute at Columbia University, New York, 23–25 February 2017.
- 4 The most notable works are Daniel Miller, *Material Culture and Mass Consumption* (Oxford: Blackwell, 1993); Steven D. Lubar and W. D. Kingery (eds), *History from Things: Essays on Material Culture* (Washington, DC: Smithsonian Institution Press, 1993); David Kingery, *Learning from Things: Method and Theory of Material Culture Studies* (Washington, DC: Smithsonian Institution Press, 1998); Bill Brown (ed.), *Things* (Chicago: University of Chicago Press, 2004); Lorraine J. Daston (ed.), *Things That Talk: Object Lessons from Art and Science* (New York: Zone Books, 2007); Daniel Miller, *Stuff* (Cambridge: Polity, 2009); Bjørnar Olsen, *In Defense of Things: Archaeology and the Ontology of Objects* (Plymouth: Rowman Altamira, 2010); Jane Bennett, *Vibrant Matter: A Political Ecology of Things* (Durham, NC: Duke University Press, 2010).
- 5 Miller, *Material Culture and Mass Consumption*, p. 142.
- 6 Hazel Conway, *Design History: A Student's Handbook* (London: Routledge, 1987), p. 9.
- 7 Judy Attfield, *Wild Things: The Material Culture of Everyday Life* (Oxford: Berg, 2000), p. 5.
- 8 For example, Kevin Davies, 'Markets, Marketing and Design', *Scandinavian Journal of Design History* 9 (1999), 56–73; Judy Attfield, *Bringing Modernity Home: Writings*

- on *Popular Design and Material Culture* (Manchester: Manchester University Press, 2007); Paul Betts, *The Authority of Everyday Objects: A Cultural History of West German Industrial Design* (Berkeley, CA: University of California Press, 2007); Kjetil Fallan, *Scandinavian Design: Alternative Histories* (Oxford: Berg, 2013); Kjetil Fallan and Grace Lees-Maffei (eds), *Designing Worlds: National Design Histories in an Age of Globalization* (New York: Berghahn Books, 2016); the detailed historiography up to 2010 is presented in Kjetil Fallan, *Design History: Understanding Theory and Method* (New York: Bloomsbury, 2010), pp. 1–54.
- 9 Jeffrey L. Meikle, *American Plastic: A Cultural History* (New Brunswick, NJ: Rutgers University Press, 1997); Peter-Paul Verbeek and Petran Kockelkoren, 'The Things That Matter', *Design Issues* 14.3 (1998), 28–42, doi:10.2307/1511892; Alison J. Clarke, *Tupperware: The Promise of Plastic in 1950s America* (Washington, DC: Smithsonian Institution Press, 2001); Kjetil Fallan, 'Goldfish Memories: Recounting Oslo's Streamlined Aluminium Trams', in Fallan, *Scandinavian Design*, pp. 117–35; Marta Filipová, 'Czech Glass or Bohemian Crystal? The Nationality of Design in the Czech Context', in Fallan and Lees-Maffei (eds), *Designing Worlds*, pp. 141–55; Jesse Adams Stein, *Hot Metal: Material Culture and Tangible Labour* (Oxford: Oxford University Press, 2017).
  - 10 For example, Marta Ajmar-Wollheim and Luca Molà, 'The Global Renaissance: Cross-Cultural Material Culture and the Creation of a Community of Taste', in Glenn Adamson, Giorgio Riello and Sarah Teasley (eds), *Global Design History* (London: Routledge, 2011), pp. 11–20; Anne Gerritsen, 'Domesticating Goods from Overseas: Global Material Culture in the Early Modern Netherlands', *Journal of Design History* 29.3 (2016), 228–44, doi:10.1093/jdh/epw021.
  - 11 Finn Arne Jørgensen, 'Green Citizenship at the Recycling Junction: Consumers and Infrastructures for the Recycling of Packaging in Twentieth-Century Norway', *Contemporary European History* 22.3 (2013), 499–516, doi:10.1017/S0960777313000258; Livia Rezende, 'Manufacturing the Raw in Design Pageant: The Commodification and Gendering of Brazilian Tropical Nature at the 1867 Exposition Universelle', *Journal of Design History* 30.2 (2017), 122–38, doi:10.1093/jdh/epx007; Kjetil Fallan (ed.), *The Culture of Nature in the History of Design* (London: Routledge, 2019).
  - 12 Kjetil Fallan, 'Our Common Future. Joining Forces for Histories of Sustainable Design', *Technoscienza* 5.2 (2015), 15–32.
  - 13 Boris Kushner, 'Organizatory proizvodstva', *LEF* 3 (1923), 97–103. The avant-gardist vision of the artist's organisational role is examined in Maria Gough, *The Artist as Producer: Russian Constructivism in Revolution* (Berkeley, CA: University of California Press, 2005).
  - 14 Aleksei Gan, *Konstruktivizm* (Tver: 2-ia Gostipografiia, 1922), p. 21.
  - 15 Aleksandr Rodchenko, *Opyty dlia budushchego. Dnevnik. Stat'i. Pis'ma* (Moscow: Grant, 1996), quoted in Ekaterina Degot', 'Ot tovara k tovarishchu: k estetike nerynochnogo predmeta', *Logos* 26.5–6 (2000), 37, [www.ruthenia.ru/logos/number/50/14.pdf](http://www.ruthenia.ru/logos/number/50/14.pdf) (accessed 11 June 2014).
  - 16 Boris Arvatov, *Iskusstvo i proizvodstvo. Sbornik statei* (Moscow: Proletkul't, 1926), p. 128.
  - 17 Boris Arvatov, 'Byt i kul'tura veshchi', in *Al'manakh proletkul'ta* (Moscow: Proletkul't, 1925), p. 79.
  - 18 Christina Kiaer, *Imagine No Possessions: The Socialist Objects of Russian Constructivism* (Cambridge, MA: MIT Press, 2005), pp. 17–28.
  - 19 For analysis of the role of design in the Cold War, see Greg Castillo, *Cold War on the Home Front: The Soft Power of Midcentury Design* (Minneapolis, MN: University of Minnesota Press, 2010).
  - 20 Sergei Oushakine, 'Dinamiziruiushchaia veshch', *Novoe Literaturnoe Obozreniie* 120 (2013), 29–34.

- 21 Sergei Tretiakov, 'Biografiia veshchi', in Nikolai Chuzhak (ed.), *Literatura fakta: pervyi sbornik materialov rabotnikov LEFa* [reprint of 1929 edition] (Moscow: Zakharov, 2000), pp. 68–72.
- 22 Igor Kopytoff, 'The Cultural Biography of Things: Commoditization as Process', in Arjun Appadurai (ed.), *The Social Life of Things: Commodities in Cultural Perspective* (Cambridge: Cambridge University Press, 1988), pp. 64–92.
- 23 Julie Hessler, *A Social History of Soviet Trade: Trade Policy, Retail Practices, and Consumption, 1917–1953* (Princeton, NJ: Princeton University Press, 2004); Amy E. Randall, *The Soviet Dream World of Retail Trade and Consumption in the 1930s* (Basingstoke: Palgrave Macmillan, 2008); Steven E. Harris, *Communism on Tomorrow Street: Mass Housing and Everyday Life after Stalin* (Washington, DC/Baltimore, MD: Woodrow Wilson Center Press/Johns Hopkins University Press, 2013); Christine Varga-Harris, *Stories of House and Home: Soviet Apartment Life during the Khrushchev Years* (Ithaca, NY: Cornell University Press, 2015); Natalya Chernyshova, *Soviet Consumer Culture in the Brezhnev Era* (New York: Routledge, 2013).
- 24 The materiality of everyday life in the USSR from the 1920s to the 1970s is addressed in Victor Buchli, *An Archaeology of Socialism* (Oxford: Berg, 2000). The most thorough examination of the role of materiality in the relationship between state and citizens is Krisztina Fehérvári, *Politics in Color and Concrete: Socialist Materialities and the Middle Class in Hungary* (Bloomington, IN: Indiana University Press, 2013). A recent volume on Russian material culture has made a progressive step in this direction: Graham H. Roberts (ed.), *Material Culture in Russia and the USSR: Things, Values, Identities* (London: Bloomsbury, 2017).
- 25 Katharina Pfützner, *Designing for Socialist Need: Industrial Design Practice in the German Democratic Republic* (London: Routledge, 2018).
- 26 Susan E. Reid, 'Destalinization and Taste, 1953–1963', *Journal of Design History* 10.2 (1997), 177–201; Victor Buchli, 'Khrushchev, Modernism, and the Fight against "Petit-bourgeois" Consciousness in the Soviet Home', *Journal of Design History* 10.2 (1997), 161–76; Iurii Gerchuk, 'The Aesthetics of Everyday Life in the Khrushchev Thaw in the USSR (1954–64)', in Susan Emily Reid and David Crowley (eds), *Style and Socialism: Modernity and Material Culture in Post-War Eastern Europe* (Oxford: Berg, 2000), pp. 81–100.
- 27 Susan E. Reid, 'Khrushchev Modern: Agency and Modernization in the Soviet Home', *Cahiers du Monde Russe* 47.1/2 (2006), 268.
- 28 Andres Kurg, 'Feedback Environment: Rethinking Art and Design Practices in Tallinn During the Early 1970s', *Kunstiteaduslikke Uurimusi/Studies on Art and Architecture/Studien für Kunstwissenschaft* 20.1–2 (2011), 26–58; Diana K. West, 'CyberSovietica: Planning, Design, and the Cybernetics of Soviet Space, 1954–1986', PhD dissertation, Princeton University, 2013; Tom Cubbin, 'The Domestic Information Machine: Futurological Experiments in the Soviet Domestic Interior, 1968–76', *Home Cultures* 11.1 (2014), 5–32, doi:10.2752/175174214X13807024691142; Tom Cubbin, *Soviet Critical Design: Senezh Studio and the Communist Surround* (London: Bloomsbury, 2018).
- 29 Alexandra Sankova, guided tour of the exhibition 'Design System in the USSR', All-Russian Decorative Art Museum, Moscow, 4 December 2017.
- 30 For example, S. O. Khan-Magomedov, *Pioneers of Soviet Architecture* (New York: Rizzoli, 1987); Larisa Zhadova, *Malevich: Suprematism and Revolution in Russian Art 1910–1930* (New York: Thames and Hudson, 1982); Susan Buck-Morss, review of Vladimir Paperny's *Architecture in the Age of Stalin* (2011), [www.paperny.com/k2\\_morss.html](http://www.paperny.com/k2_morss.html) (accessed 1 February 2015).
- 31 Paul Wood, 'The Politics of the Russian Avant-Garde', in *The Great Utopia: The Russian and Soviet Avant-Garde, 1915–1932* (New York: Guggenheim Museum, 1992).

- 32 For example, Stephen V. Bittner, *The Many Lives of Khrushchev's Thaw: Experience and Memory in Moscow's Arbat* (Ithaca, NY: Cornell University Press, 2008); Benjamin Tromly, *Making the Soviet Intelligentsia: Universities and Intellectual Life under Stalin and Khrushchev* (Cambridge: Cambridge University Press, 2013).
- 33 Cubbin, *Soviet Critical Design*.
- 34 David Raizman, *History of Modern Design* (Upper Saddle River, NJ: Pearson Prentice Hall, 2010), pp. 11–13.
- 35 Aleksandr Lavrentiev, *Istoriia dizaina. Uchebnoe posobie* (Moscow: Gardariki, 2006), p. 14.
- 36 Attfield, *Wild Things*, p. 2.
- 37 Wendy R. Salmond, *Arts and Crafts in Late Imperial Russia: Reviving the Kustar Art Industries, 1870–1917* (Cambridge: Cambridge University Press, 1996); Selim O. Khan-Magomedov, *Pionery sovetskogo dizaina* (Moscow: Galart, 1995).
- 38 David Aranovich, 'Khudozhestvennoe oformleniie dvortsia sovetov', *Iskusstvo* 4 (1938), 181–2.
- 39 Glenn Adamson et al., 'Modern Craft Studies: The Decade in Review', *The Journal of Modern Craft* 10.1 (2017), 9.
- 40 Djurdja Bartlett, *FashionEast: The Spectre That Haunted Socialism* (Cambridge, MA: MIT Press, 2010), p. 22; Jukka Gronow, *Caviar with Champagne: Common Luxury and the Ideals of the Good Life in Stalin's Russia* (Oxford: Berg, 2003).
- 41 'Postanovlenie Politburo TsKVKP (b) "O perestroike literaturno-khudozhestvennykh organizatsii"', 23 aprelia 23, 1932 g., *Partiinoe stroitelstvo* 9 (1932), 62, [www.hist.msu.ru/ER/etext/USSR/1932.htm](http://www.hist.msu.ru/ER/etext/USSR/1932.htm) (accessed 15 January 2013).
- 42 The confusion might stem from the translation of *konstruktor* as 'designer' in books on Soviet engineering.
- 43 Dmitry Azrikan, interview for the journal *Projector*, 23 September 2008, [www.designet.ru/context/interview/?id=37621](http://www.designet.ru/context/interview/?id=37621) (accessed 17 November 2012); Aleksandr Lavrentiev and Yuri Nasarov, *Russian Design: Tradition and Experiment, 1920–1990* (London: Academic Publishers, 1995), p. 47.
- 44 Sergei Khelmianov and Svetlana Mirzoian, *Mukha: Sankt-Peterburgskaia Shkola Dizaina* (St Petersburg: Iunikont Design, 2011).
- 45 Dmitry Azrikan, 'VNIITE, Dinosaur of Totalitarianism or Plato's Academy of Design?', *Design Issues* 15.3 (1999), 45.
- 46 As is evident from the only official art journal of this period, *Iskusstvo*; see also Vladimir Paperny, *Kul'tura dva* (Moscow: Novoe Literaturnoe Obozreniie, 1996), pp. 275–7.
- 47 The Central School of Technical Drawing, named after its founder, Baron Alexander Ludvigovich von Stieglitz, was opened on 29 January 1881, with the aim of preparing artists for industry. This was a part of the reform of art education in Russia which occurred in the second half of the nineteenth century and was based on Western European models. Reforms had been themselves inspired by international industrial exhibitions in Europe. In 1862 the Stroganov School of Technical Drawing was opened in Moscow; Stieglitz took this example and granted 1 million silver roubles to the Russian Finance Ministry to open a school of technical drawing in St Petersburg. The Stieglitz School gathered outstanding professors and gave its students a versatile education. After the 1917 Revolution, the school was renamed the Higher School of Decorative Arts, and in 1918 it was united with the Academy of Arts as the First State Art-Educational Workshops. In 1922 this institution was renamed the Petrograd Higher Art-Industrial Institute (Vkhutein). Thus it became a counterpart to the innovative design school in Moscow – Vkhutemas (Higher Art-Industrial Workshops), which in 1926 was also renamed Vkhutein. In 1930 both schools were closed. Khelmianov and Mirzoian, *Mukha*, pp. 13–69.
- 48 Khelmianov and Mirzoian, *Mukha*, pp. 123–5.
- 49 The Institute of Painting, Sculpture and Architecture in Leningrad was the heir of



- the Imperial Academy of Arts. After several reorganisations in the 1920s, it acquired the name of the nineteenth-century realist painter Ilya Repin in 1932.
- 50 Khelmianov and Mirzoian, *Mukha*, pp. 125–39.
  - 51 Russian State Archive of Literature and Art, Moscow (hereafter RGALI), f. 2460 op. 1, d. 337, l. 4.
  - 52 Iurii Soloviev, *Moia zhizn' v dizaine* (Moscow: Soiuz dizainerov Rossii, 2004), pp. 67–111; Vladimir Paperny, 'Vospominaniia o futurologii', in *Mos-Angeles-2* (Moscow: Novoe Literaturnoe Obozreniie, 2009), p. 70; Iurii Vasiliev, 'Korol' dizaina', *Itogi* 884 (20 May 2013), [www.itogi.ru/arts-spetzproekt/2013/20/190033.html](http://www.itogi.ru/arts-spetzproekt/2013/20/190033.html) (accessed 1 June 2012).
  - 53 Jonathan Woodham, *A Dictionary of Modern Design* (Oxford: Oxford University Press, 2004), p. 395.
  - 54 Vladimir Runge, *Istoriia dizaina, nauki i tekhniki. Kniga vtoraiia* (Moscow: Arkhitektura-S, 2007), pp. 225–6.
  - 55 RGALI, f. 2943, op. 1, l. 34.
  - 56 Central State Archive of Literature and Art, St Petersburg (hereafter TsGALI SPb), f. 266, op. 1, d. 291, l. 70; RGALI, f. 2493, op. 1, d. 2470, l. 34.
  - 57 Catherine Cooke, 'Modernity and Realism: Architectural Relations in the Cold War', in Susan E. Reid and Rosalind P. Blakeley (eds), *Russian Art and the West: A Century of Dialogue in Painting, Architecture and the Decorative Arts* (DeKalb, IL: Northern Illinois University Press, 2007), p. 173.
  - 58 'Direktivny po piatiletnemy planu razvitiia SSSR na 1951–1955 gody', *Pravda*, 20 August 1952, pp. 1–2.
  - 59 TsGALI SPb, f. 78, op. 4, d. 386, l. 1–3.
  - 60 'On Liquidation of Excesses in Planning and Building', 4 November 1955, [www.sovarch.ru/postanovlenie55/](http://www.sovarch.ru/postanovlenie55/) (accessed 28 August 2011).
  - 61 Mark B. Smith, 'Khrushchev's Promise to Eliminate the Urban Housing Shortage: Rights, Rationality and the Communist Future', in Melanie Ilic and Jeremy Smith (eds), *Soviet State and Society under Nikita Khrushchev* (London: Routledge, 2009), pp. 26–7.
  - 62 RGALI, f. 2082, op. 1–2, l. 1.
  - 63 In this period, the terms 'decorative', 'applied' and 'decorative-applied' were often used interchangeably, because the choice of the best term for art related to mass production was a subject of debate among specialists.
  - 64 RGALI, f. 2943, op. 1, d. 2514, l. 2.
  - 65 Castillo, *Cold War at the Home Front*, pp. 148–70; Walter L. Hixson, *Parting the Curtain: Propaganda, Culture and the Cold War* (New York: St Martin's Press, 1996), pp. 151–215; Susan E. Reid, 'Who Will Beat Whom? Soviet Popular Reception of the American National Exhibition in Moscow, 1959', *Kritika* 9.4 (2008), 855–903.
  - 66 RGALI, f. 2082, op. 2, d. 2192, l. 10.
  - 67 The British Trade Fair, jointly sponsored by the Association of British Chambers of Commerce and the All-Union Chamber of Commerce of the USSR, and organised by Industrial Trade Fairs Ltd, opened in May 1961 in Sokol'niki Park in Moscow, where the American National Exhibition had been held in 1959. The Soviet Trade and Industrial Exhibition was held at Earl's Court in London on 7–29 July 1961. 'Selling to Russia', *Design* 145 (January 1961), 67; 'USSR at Earl's Court', *Design* 154 (October 1961), 42–9.
  - 68 Azrikan, 'VNIITE', 48.
  - 69 RGALI, f. 2082, op. 2, d. 2171. l. 3.
  - 70 Runge, *Istoriia dizaina, nauki i tekhniki*, p. 229.
  - 71 Azrikan, 'VNIITE', 50.
  - 72 Katarina Serulus, "'Well-Designed Relations": Cold War Design Exchanges between Brussels and Moscow in the Early 1970s', *Design and Culture* 9.2 (2017), 147–65, doi:10.1080/17547075.2017.1326231; Soloviev, *Moia zhizn' v dizaine*, pp. 112–228.

- 
- 73 'Past Boards of Directors', World Design Organization, <https://wdo.org/about/people/board/past-boards/> (accessed 4 April 2019).
- 74 Runge, *Istoriia dizaina, nauki i tekhniki*, pp. 233–4; Soloviev, *Moia zhizn' v dizaine*, pp. 199–227.
- 75 Andres Kurg, 'The Prehistory of Contemporary Environment: Multimedia Program in the ICSID '75 Congress in Moscow', in Anna Romanova et al. (eds), *The Islands of Yuri Sobolev* (Moscow: The Moscow Museum of Modern Art, 2014), pp. 274–8.
- 76 TSGALI SPb, f. 781, op. 1, d. 1, ll. 8–10; Runge, *Istoriia dizaina, nauki i tekhniki*, pp. 366–70.
- 77 Z. Sherengovaia, 'O kombinatakh dekorativnogo iskusstva i ikh zadachakh', in N. Stepanian and V. R. Aronov (eds), *Sovetskoe dekorativnoe iskusstvo' 76* (Moscow: Sovetskii khudozhnik, 1978), pp. 98–106.
- 78 Ksenia Guseva, 'Anna Andreeva and her Experimental Designs', Russian Art + Culture, posted 13 September 2018, [www.russianartandculture.com/anna-andreeva-and-her-experimental-designs/](http://www.russianartandculture.com/anna-andreeva-and-her-experimental-designs/) (accessed 24 September 2018).
- 79 Ibid.; RGALI f. 2082, op. 3, ed. Khr. 866; Julia Vasilievna Gusarova, 'Leningradskaia keramika kak Fenomen Otechestvennoi Kul'tyry Vtoroi Poloviny XX veka', PhD dissertation, Herzen State Pedagogical University of Russia, 2011, p. 76.
- 80 Betts, *The Authority of Everyday Objects*, p. 150.

# 1

## The aesthetic turn after Stalin

In October 1967 readers of the journal *Dekorativnoe Iskusstvo SSSR* were probably surprised to find that the latest issue lacked its usual table of contents and was mostly devoid of text. Instead, they were confronted with forty-five pages of high-quality colour and black-and-white images of objects produced in the Soviet Union over the past five decades since its founding. This is how the journal's editors – made up of decorative artists, designers, critics and philosophers – chose to celebrate the jubilee of the October Revolution, joining the chorus of festivities organised all over the country in 1967. The editorial, appropriately entitled 'Glory to the 50th Anniversary of the Great October Socialist Revolution', explained that they wanted to 'give the floor to the wordless yet eloquent witnesses to our history, the products of the creative spirit of artists'.<sup>1</sup>

The following pages contained no text, only the images of the 'witnesses': monuments to the Soviet Constitution, Karl Marx and Jean-Paul Marat, built in 1918–19 in Moscow according to the Lenin Plan of Monumental Propaganda; a 1920 porcelain saucer, 'Red Baltic Fleet', decorated with the figure of a revolutionary sailor; the 1935 post-constructivist pavilion of the Moscow metro station Red Gates by the avant-garde architect Nikolai Ladovskii; an ensemble of traditional clay toys produced by Tajik, Uzbek and Russian craftsmen in 1960–61; the 1967 memorial to the victims of Nazism on the site of the labour camp Salaspils (Latvia); a 1967 *pulegoso*<sup>2</sup> glass vase made by Moscow artists; a selection of late 1920s textile patterns with industrial motifs; the interior of the Soviet Pavilion at Expo 1967 in Montreal; a decorative painting of a peacock by a village craftsman from the Kiev region; the recently finished high-rise building of the COMECON headquarters on New Arbat Street in Moscow; and many more (plate 1). The gallery concluded with a black-and-white photo of a 1920s statue of Lenin in Batumi, Georgia, resolutely facing the opposite page, coloured a pure, simple red.

To today's observers, the image gallery is striking because of the eclecticism of themes, types, scales and techniques within it. Its principles appear opaque. In a way, they can be considered similar to those of Jorge Luis Borges's Chinese Encyclopaedia, famously invoked by Michel Foucault in the preface to *The Order of Things*, in which the reader faces the 'oddity of unusual juxtapositions'. What was the reason for placing side-by-side a war memorial, a porcelain cup, the interior of a youth café and a monument to Lenin? The simple answer would be that they were all produced in the Soviet Union, but this does not explain precisely why these objects in particular were chosen. It also does not explain the slightly mixed chronology (interchanging objects from the 1920s and 1960s) or the conspicuous absence of anything from the late 1930s to the 1950s. The question remains: what was the logic behind this order of things?

I suggest that the commonality between these images, which would have been immediately comprehensible to the journal's readers, was a particular aesthetic that gradually emerged in the Soviet Union after Stalin's death in 1953 and became pronounced by the late 1960s. I do not use 'aesthetics' as it is used in art theory or in the philosophy of art. Instead, I interpret aesthetics in a broader sense, one first proposed by Jacques Rancière, as 'a specific regime for identifying and reflecting on the arts: a mode of articulation between ways of doing and making, their corresponding modes of visibility, and possible ways of thinking about their relationships'.<sup>3</sup> This new aesthetics came to replace the Stalinist regime of arts, which, following Rancière, can be deemed representative, that is, it adhered to a hierarchy of genres and subject matter and privileged speech over visibility.<sup>4</sup> Within such a representative regime, the publication of the image gallery in *Dekorativnoe Iskusstvo SSSR* discussed above would have been unthinkable. Even the idea of a special journal just for decorative art would have been impossible. *Dekorativnoe Iskusstvo SSSR* did not exist until December 1957. Although the rhetoric and meanings of art criticism changed throughout the Stalin era, text always overshadowed visual imagery. For example, the article 'Thirty-Five Years of Soviet Art' by the president of the Soviet Academy of Arts Aleksandr Gerasimov, published in the official art journal *Iskusstvo* in November 1952, included very few images – only figurative painting and heroic sculptures. This was accompanied by a long narrative glorifying the triumph of socialist realism with an abundance of references to the great works of Lenin and Stalin. The images were only illustrations for the text. By contrast, in the October 1967 issue of *Dekorativnoe Iskusstvo SSSR* the text was reduced only to captions, making the images the primary carriers of the ideals of the Revolution. In other words, the images themselves represented the new, post-Stalin order of things.

The aesthetic regime of arts emerged in Soviet Russia in place of the representative one in the 1950s, peaked in 1960, and took on a more or less clear shape by the start of the 1960s. I call this process the *aesthetic*

*turn* and consider it the cornerstone of post-Stalin Soviet modernism. The aesthetic turn was not just a return to the avant-garde or to the cultural pluralism of the 1920s, which had not been limited to the avant-garde. Rather, it was a gradual formation of new concepts, largely driven by people who had been connected to avant-garde movements in the 1920s. Therefore, the aesthetic turn refers to change without neglecting the importance of continuity. This chapter offers an overview of the key concepts of the new aesthetic regime of arts and provides background for my analysis of late socialist objects in the following chapters. In the overview I describe the following concepts: first, realism as a specific quality of things, not depictions of them; second, contemporaneity as a measure of the social relevance of an object; and third, taste as a tool for constructing social hierarchies and probing the limits between authenticity and appearance.

### Realism reconsidered

In the history of art, the Stalin era in the Soviet Union is widely known as the period of socialist realism. According to the 1934 formulation of the chief Party ideologist Andrei Zhdanov, presented at the First All-Union Congress of Soviet Writers, socialist realism was not a style but a method of art-making (its eclectic character is often emphasised),<sup>5</sup> a working method obligatory for artists in all fields. Despite its totalising rhetoric, socialist realism was not monolithic. In fact it had different faces depending on the artist, the genre and the medium.<sup>6</sup> It did not even preclude artistic individuality; this was exemplified by the cases of the painters Aleksandr Deineka and Aleksandr Laktionov, both of whom were incorporated into the framework of socialist realism despite being vastly different artists.<sup>7</sup> Nonetheless, regarding visual arts, socialist realism had a common feature: according to the official formula, an artist was expected to portray reality ‘in its revolutionary development’<sup>8</sup> – that is, to visualise the state’s promises by depicting recognisable life forms in the desired manner.

Formally, socialist realism remained the only permitted artistic method until perestroika. However, with the changes in cultural policies after Stalin, including the rise of decorative art and the emergence of the design profession, the notion of socialist realism could not remain the same. To fulfil the modern socialist material culture, the notion of socialist realism had to be updated. What follows is an overview of theoretical and practical attempts to adapt socialist realism to what Susan E. Reid calls the ‘Khrushchev Modern’<sup>9</sup> – the move towards the mass industrial production of commodities and to mass consumption.

In the early 1950s decorative artists gave topicality priority over materiality. For example, students of the newly established schools of art and industry were expected to render the powerful, positive image of a contemporary – a type. This was an unavoidable requirement of Stalinist

artistic policy, which had spread from literature to all the visual arts. The intention was to portray the ‘correct type’ of Soviet personality, a model for identification, while all the decorative techniques – use of light, colour, material, texture – were just means to achieve this. This is evident in the Leningrad critic V. Kalinin’s review of the 1953 graduate projects of the Mukhina School. He praised the works that had received the highest grades for the skilful adaptation of their materials to the subject matter. According to this logic, material such as stained glass was just a tool for creating figurative imagery in architecture. At that time, the Moscow Research Institute of Decorative and Applied Art was developing new techniques for decorating stained glass, such as etching, engraving and counter-reliefs. According to Kalinin, these innovations enabled the artist to ‘render more adequately and realistically life-affirming images of our reality, first of all, images of Soviet people in the fullest of their spiritual wealth’. He used two examples to illustrate his point:

The stained glass by the student V. Statun, depicting a girl collective farmer labouring, is carried out in a gold-yellow, sunny range of colours, which perfectly expresses its ideological content – free labour in our country as a source of joy and abundance. The stained glass is rich in chiaroscuro transitions without tinting [...]

A subtle mastery of various techniques is demonstrated by Galazova in her stained glass ‘Abundance of Ukraine’, rich and bright in colour, designed for the Kharkov bus station.<sup>10</sup>

What is noteworthy here is not the heroic and celebratory imagery – a universal and predictable feature of late Stalinist art – but the attention given to the very specific, technical skills of the artists in the official critique. The inherent qualities of glass were connected (or, rather, subordinated) to the Soviet symbolism of cheerfulness, prosperity and abundance. The traditional type of decorative art was used in a new way: instead of producing the transcendent, supernatural imagery of saints in Gothic churches, stained glass now generated expressly earthly, hyper-natural personifications of Soviet ideals: ‘free labour’, ‘abundance’, etc. Ironically, the transparency of glass was also intended to produce a divine effect – the true fulfilment of a miracle, according to Soviet mythology.<sup>11</sup>

Likewise, students in artistic ceramics employed traditional forms to render distinctly Soviet content. Kalinin marked a pair of porcelain vases with the portraits of Lenin and Stalin (co-created by S. Bogdanova and K. Kosenkova) as the most important works of the 1953 graduates of the Mukhina School. In Kalinin’s description, the vases’ ‘well-composed and sublime’ forms referred to antique amphorae, while their bodies served as ground for the subtly painted portraits in frames of ‘festive gold ornament’ – perfectly in tune with the classicist sympathies inherent to socialist realism. As properly ‘orthodox’ artworks, the vases were exhibited in the State Hermitage Museum.<sup>12</sup>

Yet one should not overestimate the role of figurative elements in early 1950s decorative art. Although encouraged, realistic depiction was avoidable. First, purely ornamental decoration was justified if it was based on folk art, which made it art of the ‘people’ and ‘democracy’. Second, not all realistic motifs were praised indiscriminately; that was reserved for art that the critics considered masterfully adapted to its medium. Moreover, the critique of ‘easel style’ (*stankovizm*) in applied and decorative art was present as early as 1953 and became stronger with the unfolding of Khrushchev’s Thaw. A heroic, perfectly socialist subject matter, even when combined with an artist’s supreme skill, was not enough to guarantee a successful result: the medium also had to be taken seriously.

In the spring of 1955 *Iskusstvo*, an official journal of the Artists’ Union of the USSR, published an article written by the prominent art historian Aleksandr Saltykov. The article argued that decorative art requires a different methodology of depiction compared to easel art. Saltykov asserted that the form, proportionality and naked beauty of an object should serve as the basis for decoration, and this decoration should not be a depiction with atmospheric perspective. Therefore, ‘of primary importance are the foreground, the clear, expressive contours, and the rhythmically arranged and harmonised silhouettes’.<sup>13</sup> Furthermore, Saltykov reasoned that decorative art was not psychological: the decorative artist chooses and arranges real phenomena ‘with great freedom’, and sometimes even selects only certain elements of those phenomena. Decorative compositions can be very close to illusory depiction but can also sufficiently differ from it. Additionally, ‘one of the indispensable qualities of a decorative artist is wide and daring fantasy’. The article clearly stated that socialist realism was by no means a universal method and that it could even become kitsch and banal when misapplied. Saltykov meticulously listed the atrocities produced by overly ardent followers of realist principles:

A glass factory in Diat’kovo [a town in the Briansk region] produces flower vases out of opal glass, with ugly forms, with the depiction of a monumental statue, ‘A tractor driver and a woman collective farmer’, copied from a photo. The depiction is integrated neither with surrounding ornaments nor with the object itself, and these vases can serve as examples of bad taste. The Leningrad factory of lead glass tableware fabricates similar vases, depicting the monument to [General Aleksandr] Suvorov, almost unrecognisable and also unrelated to the vases’ shapes. ‘Mosstamp’ factory produces metal cigarette cases with the bas-relief depiction of three epic heroes [from the famous 1898 painting] by [Viktor] Vasnetsov. Not much remained from the heroes [*ot bogatyrei malo chto ostalos*’], their distorted figures are in disharmony with the case, and the object indeed looks defective.<sup>14</sup>

Further examples included clumsy adaptations of famous scenes from nineteenth-century Russian paintings for the decoration of powder cases, purses, writing pads and lacquer boxes.

About a year later, *Iskusstvo* published a polemical article by the young Leningrad philosopher and art historian Moisei Kagan entitled ‘On the Specificity and Essence of Decorative-applied Art’.<sup>15</sup> Everywhere except in the title, Kagan preferred to use the term ‘applied art’ over ‘decorative’ in order to dissociate it from decoration, which he considered superficial, holding ‘decorative’ to be a pejorative term. While he disagreed with Saltykov on certain points, Kagan also contended that applied art is not illusory by nature and does not represent anything, but rather fulfils concrete practical needs. In this respect, it is akin to architecture. Of the two aspects of architecture and applied art – practical and what Kagan calls ‘ideological-aesthetic’ – the former is more important. Artistic content and aesthetic form – the elements fulfilling ideological function – should be subordinated and *applied* to the practical function, Kagan argued. Thus, he concluded, architecture is also an applied art and only distinct because of its monumental character.<sup>16</sup> Commenting on this same article at a professional meeting several months later (shortly after the famous XXth Party Congress, where Khrushchev denounced Stalin’s repressions), Kagan presented his vision of ‘everyday’ socialist realism:

I believe that one of the main principles of applied art and one of the requirements of socialist realism is a specific simplicity, concision, and modest use of decorative means, which are opposed, on the one hand, to the decorativist style that until recently prevailed in our architecture and applied art, and, on the other hand, to the asceticism of Constructivism that absolutely rejected any use of decorative means.<sup>17</sup>

Here, Kagan skilfully used forms of authoritative discourse to update the notion of socialist realism – *mutatis mutandis*, which could be applied to state socialism, in the spirit of de-Stalinisation. His goal was to correct the misdeeds of the recent past, arguing against corrupt Byzantine grandeur and advocating for a return to the original Bolshevik ethos, but avoiding what he perceived as the avant-garde’s asceticism. Stalinists and the ‘ancients’ of art were quick to respond.

The main counterattack came from Nina Iaglova, an established art critic. She objected that applied art *is* figurative, because it is always based on some recognisable motif, even if often indirectly. Iaglova illustrated this argument with slides showing ancient artefacts (pre-Scythian, Scythian, Egyptian and Russian artefacts of the seventeenth century): vessels resembling birds, tables with ‘animal’ legs, etc.<sup>18</sup> The only two contemporary examples given by Iaglova were art pieces of late Stalinism: lacework ‘Squirrels’ (she did not mention the artist) and a machine-made wall carpet by the artist Eremeeva, ‘The Feast of Harvest’. Both, I suggest, are examples of what can be called ‘lyric’ realism, which would soon come to be seen as Stalinist kitsch by decorative art reformers. Speaking of the ‘Squirrels’, Iaglova noted enthusiastically:



This object is meant to live in our *byt*, to bring warmth and joy into our life. The artist achieves this impression through the theme of Russian nature, which, maybe, could be expressed in painting far more concretely; but applied art, [in particular] lace, has its own means, and we enjoy looking at this poetic image of Russian nature ... Every type of art has its own degree of closeness to nature, its own measure of conditionality.<sup>19</sup>

This kind of realism, with its references to warmth, enjoyment and poetic feeling, can be termed 'lyric', as a counterpart to the 'epic' realism of celebratory glass, ceramic or textile tapestries.

In response, Kagan argued that an image (*obraz*) should not be confused with a portrayal (*izobrazheniie*). He added that all of the arts are image-bearing (*obraznye*) in their own way but that not all of them are figurative (*izobrazitel'nye*).<sup>20</sup> Kagan ultimately rejected both 'epic' and 'lyric' versions of socialist realism, offering a 'practical' one instead: 'I love art, but a chair is made for sitting, a cup for drinking, clothes for wearing, and architecture for living. And when this elementary and prosaic fact is forgotten, there appear various aesthetically unpleasant things.' This indicates that for Kagan not only does form follow function, as Louis Sullivan put it, but *artistic image* follows function.<sup>21</sup>

A particularly interesting instance of the post-Stalin reconsideration of realism was made by the art critic Aleksandr Chekalov at a lecture in the decorative-applied art section of the Moscow branch of the Artists' Union in January 1959. Like Kagan, Chekalov belonged to a young generation of art critics (he was 31 at the time). His lecture, titled 'Peculiarities of Reflecting Life in Artistic-Industrial Objects', outlined the principles and objectives of emerging Soviet design. At the start, Chekalov proposed three major questions for discussion:

- 1 What are artistic-industrial items – art or non-art? If [they are] art, can they be ascribed to visual art? *Where is the border between the artistic and the non-artistic?* [My emphasis.]
- 2 Can the term 'realism' be used regarding decorative-applied art? If yes, how should we deal with the notions of typicality [*tipichnost'*], artistic image and so on? Because, you know, we should speak of the standard [*tipovoil*] [items], but this is a different matter.
- 3 If we speak of realism, should we then speak of the opposite notions – formalism or abstractionism? Can we, for example, call geometrically shaped items of decorative<sup>22</sup> art 'abstract'?<sup>23</sup>

Chekalov's agenda can be viewed as ranging from the general philosophical question 'Where is the border between the artistic and the non-artistic?' to the more particular problem of resolving the canonical vision of realism with the practical tasks of industry. The latter, he emphasised, was an urgent problem for Soviet art theory.

In order to solve the conundrum of the unlikely marriage of realism and decorative and 'industrial' art, Chekalov proposed a 'revisionist'

theory of realism. His explanation sounds like an argument against Kant's theory of disinterested aesthetic judgement:

However ingenuously we perceive this or that object of decorative art – a rug, a statuette, an architectural decoration, wallpaper, furniture, a toy – we always mentally evaluate it. The basis of this evaluation is our general impression of this object, depending on whether we call it beautiful or not beautiful. Even the most superficial analysis makes us realise that we associate the beautiful with the living. Our eye distinguishes between 'vibrant' and 'dead' forms, between colours and lines [which are] intensive, taut, or, in contrast, languid. We always prefer bold, melodious, rich details and reject those that look dry, stiff and stunted. The vibrant for us is a kind of a synonym for the artistic.<sup>24</sup>

Evidently, the speaker downplays the concept of 'realism' by replacing it with the notion of vibrancy (*zhivost'*) and equating it with beauty. This notion is convenient, first, because it corresponds to the Soviet cult of health, cheerfulness and physical culture, and, second, because it is flexible enough to extend to stylised figurative and even non-figurative images. Thus, Chekalov argued that the characters in Greek vase painting or the grotesque figures of birds and animals that decorate ancient and folk vessels are no less vibrant than highly realistic art forms. Furthermore, he highlighted the vibrancy of geometric objects, ornaments and even 'monochromatic yet texturally expressive fabrics'.<sup>25</sup> Note the parallel with Iaglova's reasoning: if for her the animalistic forms of ancient artefacts were an argument in favour of figurativeness, for Chekalov they were valuable because of their stylised character, their particular abstraction from nature. Objects with very naturalistic shapes are often the worst, he argued. Naturalism is opposed to the 'vibrant beauty' that only bears a slight resemblance to reality; the viewer needs to recognise this resemblance and, therefore, to be attentive rather than passive in the act of perception.

While his critique of naturalism in painting corresponded to the official Soviet art theory of the early 1950s,<sup>26</sup> Chekalov's talk is notable because of how he implicitly defended abstraction: 'Even simple checks and chequers can be extremely "vivid" and full of artistic content, but they can also be dry, rigid, and "dead" like a technical drawing. It depends on intention and implementation.'<sup>27</sup> Chekalov argued that in art any close resemblance to life is deadly and repulsive, explaining that

We like the vibrant, the vital, but our taste requires that this vibrant, sensible, concrete become more abstract, lose its immediate concreteness, in a way, die as a concrete phenomenon. Then it would re-emerge in a completely different quality – as something absolutely unlike the habitual forms, built according to different principles. And only such a converted form is perceived as 'vibrant'; it suddenly gives us a new wonderful idea of the whole sensible, concrete, genuine life in all its beauty and variety.<sup>28</sup>

To justify this odd claim that the living should symbolically die and be resurrected in art, Chekalov relied on Marx's authority, but, peculiarly, that of a young Marx. Evidently, Marx's 1844 'Economic and Philosophical Manuscripts', particularly the part on alienated labour, became the most important point of reference for the generation of art critics during the Thaw. Special attention was given to the passage where Marx compares production processes between the animal and human world. While the animal produces only according to the immediate needs of itself or of its young, human beings can also produce 'free of physical need'; if the animal builds according to the standard of its species, a human being creates 'according to the laws of beauty'. Thus, humans' production is creative: it is a means of self-production 'not only intellectually, as in consciousness, but also actively in a real sense' as humans 'see themselves in a world they made'.<sup>29</sup> Drawing on this point, Chekalov portrays art objects as a 'real product of conscious human labour', as a human being's self-expression with the spiritual dimension, including one's aesthetic views.<sup>30</sup> Consequently, any human-made – or for that matter human-designed and machine-made – object is an expression of real life and real creative labour. We evaluate objects of 'everyday art' (*bytovogo iskusstva*) by human measure, and therefore good objects are those that correspond to our ideas of convenience and beauty alike, concluded Chekalov, anticipating Soviet designers' obsession with ergonomics.<sup>31</sup> From precisely this perspective, he appreciated folk art: its forms are organic and functionally justified.<sup>32</sup>

Further, Chekalov raised the problem of contemporary industrial production in relation to individuality. He admitted that 'the image of objects gradually becomes more and more general, that is to say, international. It more and more shows an abstract person, a human being as such ... Material culture knows no borders.'<sup>33</sup> This was a progressive argument for 1959, devoid of the usual reservations about the irreconcilability between socialist and capitalist values. However, what bothered Chekalov was not the danger of bourgeois consumerism but the threat to artistic individuality. He advocated researching better intrinsic qualities of materials, varying the treatments of surface, and creative uses of colour as ways of reducing such a threat. He described diverse qualities of industrially produced objects in a strikingly picturesque language:

Mass in the ready article is already not just a quantity of material but also a certain quality of a three-dimensional form: monumentality or fragility, lightness, completeness or openness and so on. The borderline of mass is not only the boundary of volume, but also an artistically found contour. The line itself becomes expressive – not just straight or curved, but flexible or restless, rhythmic or melodic. All the elements of form appear as if in the endless clash and movement and at the same time in harmonic coordination and unity. It is precisely this that we perceive as 'vibrant' in the best items of everyday art.<sup>34</sup>

This passage is noteworthy for two reasons. First, there is virtually no official cliché and no trace of authoritative discourse. Second, there is a clear (even if unintentional) echoing of the prominent art historian Nikolai Punin's description of Vladimir Tatlin's famous Monument to the Third International in 1919:

The form wants to overcome the matter, the force of gravitation; the force of resistance is big and massive; straining the muscles, the form seeks for emancipation along the most resilient and dynamic lines the world knows – the spirals. They are full of movement, striving, running, and they are tight like creative will and strained muscle.<sup>35</sup>

Just like the two counter-spirals of Tatlin's tower, the elements of form in Chekalov's 'perfect object' are in constant conflict and movement. Chekalov's organic metaphor is reminiscent of Punin's portrayal of the tower as a Promethean man, and, more broadly, reminiscent of the avant-garde obsession with drawing parallels between the organic world and industrial art.<sup>36</sup>

Finally, Chekalov forecast two ideas that would become very popular among Soviet designers a decade later – the design of environments and research on consumers' opinions. First, he claimed that a properly skilled and dedicated applied artist could humanise not only a single object of his or her making, but 'the whole sphere of activity related to this object'. Thus, a gunsmith does not just produce a rifle but 'organises the entire process of hunting', while 'sometimes human life depends on the form of his items'. Similarly, a tailor not only fits the seams of a piece of clothing, but is also responsible for making the client a better person by giving him or her a proper outfit. The same applies to the designer of a pavilion, a bus, a canteen.<sup>37</sup> Second, according to Chekalov, the humanism of this new art lay in its openness, allowing a consumer to actively participate in its making through creating ensembles of interior, dress and so on. Notably, this explanation of humanism has a didactic note: 'every person must be an artist, must have an active artistic taste'.<sup>38</sup> Therefore, when being invited to participate in the creative process, an imagined consumer is simultaneously pressed to accept the standards of taste established by the experts. In his concluding remarks, Chekalov urged artists to 'break the customs' and reflect in their art the 'new pulse of life', equating realism with functionality and feasibility, and formalism, conversely, with pretentiousness and uselessness.<sup>39</sup>

This argument provoked by Chekalov's concept of vibrancy was in itself vibrant. Some colleagues repudiated his reconceptualisation of formalism. Maria Nazarevskaja reminded Chekalov of the danger attached to abstract artworks that had been exhibited in Moscow during the International Youth Festival in 1957 and that were currently being shown at the exhibition 'Art of Socialist Countries' in the Manege exhibition hall.<sup>40</sup> She argued

that many artists' turn to the West as a source of fashion was simply due to a fear of seeming boring. Nazarevskaia went so far as to compare the adoption of geometric patterns in west European design to the widespread use of the swastika in Europe as a visual symbol of Nazi propaganda in the 1930s (a strange position from a Vkhutein graduate, whose textile patterns of the 1930s were based on highly stylised human figures and objects).<sup>41</sup>

However, there were sympathisers with Chekalov too: art historian Sergei Temerin noted that nature itself contains abstraction to some extent, and is thus appropriate for useful artworks. Pointing to the art exhibited in the room where the meeting took place, Temerin remarked: 'There is a rug, it is pictorial, but if a contemporary artist, a Soviet artist, exhibited a picture like this, he would be torn into pieces for showing pure formalism.'<sup>42</sup> The artist Grigorii Zamskii claimed that current ideas of realism and decoration were outdated. They were too narrow and reductionist:

The point is that if we look at all our fabrics, we will see virtually the same motifs everywhere, repeated in endless variations – these will be geometric, animalistic or floral ornaments. But our world is much richer. When a contemporary artist, in particular a Western artist, starts reflecting on today's world on a broader scale, it seems unusual at first, and many think that it is non-realistic. Currently I am working on decorating the pavilion 'Science' [for the All-Union Exhibition of People's Economy], and when I encounter drawings and photos of micro-organisms, I see there a lot of amazing motifs for textile patterns. Take various sections that we can see through the microscope; take animal organisms, some molluscs or shells – these are amazing things, but we do not see and do not repeat them [in our patterns].<sup>43</sup>

Zamskii questioned the ideological dichotomy of 'realism versus abstractionism': the abstract can also be organic, and therefore also realistic.

Although the idea of vibrancy per se did not generate a clear-cut artistic trend in late Soviet art, it nonetheless offered the possibility of criticising the principles of new Soviet modernism that were being formed in the late 1950s. This critical view, in turn, affected actual artistic production, which diverged from the strict requirements of standardisation and utility. Although far from Jane Bennett's post-anthropocentric notion of vibrancy,<sup>44</sup> the post-Stalin discussion of vibrant things in the Soviet Union signalled the growing self-reflexivity of applied artists and anticipated the extensive debates about design criteria that would unfold throughout the following decades in late socialism.

### Up-to-date materialities

As studies of socialist material culture clearly demonstrate, design in socialist countries was an integral element of socialist modernity. Notably, the landmark exhibition at the Victoria and Albert Museum that manifested the growing interest in socialist design was entitled (quite provocatively)

‘Cold War Modern’.<sup>45</sup> The leading historian of post-war Soviet design Susan E. Reid wrote of ‘modernization in the Soviet home’ and characterised the move towards mass housing and mass consumption, attended by changes in visual culture, as the ‘Khrushchev Modern’.<sup>46</sup> Recent scholarship argues that design in the socialist bloc and in the USSR in particular was a symptom of modernity, a tool of modernisation, a modern phenomenon, as well as a part of international modernism (notwithstanding all the official pronouncements against ‘bourgeois modernism’).

To be precise, all these terms that extend from the root word ‘modern’ are highly debated and polysemantic. If we take the understanding of modernism as the critique of, or resistance to, modernity,<sup>47</sup> then the meaning of design in socialist society appears quite ambiguous. Although Soviet design was generated by modern technology and science and influenced, through competition, by Western consumer culture, it could also offer a critical stance on Soviet modernity itself, particularly this modernity’s technocratic aspects.<sup>48</sup> In the context of Soviet design, modernity can also be considered in the immediate sense of ‘contemporaneity’ or ‘being up-to-date’, both translated into Russian as *sovremennost’*, literally, ‘in tune with the time’. This was the notion that guided designers in their actual work. The abstract idea of modernisation was fuelled by professionals’ desire to be cutting-edge. How was this desire translated into concrete strategies of updating consumer goods, interiors and outdoor decorative objects? While designing an aircraft or a vacuum cleaner in the 1960s is clearly a modernising act, what does it mean for a porcelain or textile designer to be up-to-date? Does a glass artist become ‘contemporary’ only when she or he also starts working with such innovative materials as plastic?

These questions prompt an inquiry into the very possibility of a useful, tangible object expressing the spirit of a present time, especially as defined by the rapid development of science and technology, vibrant consumer culture and fashion. In his attempt to arrive at ‘thing theory’, Bill Brown suggests that the objects of everyday life are not only constituted by consumer desires and affections, but also by the inevitability of obsolescence. He writes about ‘a basic disjunction, a human condition in which things inevitably seem too late – belated, in fact, because we want things to come before ideas, before theory, before the word, whereas they seem to persist in coming after: as the alternative to ideas, the limit to theory, victims of the word’.<sup>49</sup> According to Brown, the only way for a thing to escape belatedness is to move from everyday life into the realm of art, where it would recapture an affective power. A Surrealist readymade or Claes Oldenburg’s Pop-art ‘sculptures’ are not ‘dead commodities’, like their obsolescent everyday-life prototypes, but ‘living works’ that inspire the viewer to reflect upon the meaning of things and their functions. Thus, in Brown’s example, Oldenburg’s 1999 *Typewriter Eraser* of shiny chrome possesses the power ‘to dramatize the generational divide and to stage (to

melodramatize, even) the question of obsolescence'. He then generalises: 'Released from the bond of being equipment, sustained outside the irreversibility of technological history, the object becomes something else.'<sup>50</sup>

Considering Brown's argument along with Rancière's concept of the aesthetic regime of arts, I suggest that Soviet designers aspired to release the object from the doom of obsolescence by transcending the 'basic disjunction' between ideas and things and between art and everyday life. In this attempt, they relied on the theory of productivist art, which notably developed concurrently with Surrealism.<sup>51</sup> Boris Arvatov stated the following in his 1925 article 'Everyday Life and the Culture of the Thing' (*Byt i kul'tura veshchi*): 'The construction of proletarian culture, that is, of a culture consciously organised by the working class, requires the elimination of that rupture between things and people that characterized bourgeois society.'<sup>52</sup> Arvatov explained that as soon as class barriers fall, so do the divisions between labour and daily life and between production and consumption. In a bourgeois society, things are passive and static – merely ready-made objects to be rearranged (Arvatov's argument, I would suggest, is aptly illustrated by Duchamp's readymades). In the upcoming proletarian society, on the contrary, the thing becomes dynamic and active: 'The mechanism of a thing, the connection between the elements of a thing and its purpose, were now transparent, compelling people practically, and thus also psychologically, to reckon with them, and only with them.'<sup>53</sup> Such 'affective' objects<sup>54</sup> seem to be immune from obsolescence and, therefore, always up-to-date. Arvatov's 'dynamised' thing offers the possibility of continuous updating, in tune and in connection with the world of technology. Was this idea implemented, at least partially, in industrialised Soviet society, as it faced competition with Western consumerism in the 1950s and 1960s? This question will be explored throughout the following chapters. As a starting point, I consider the exercise in updating material culture conducted at the turn of the 1960s in relation to the construction of the Moscow Pioneer Palace. This case is significant as a landmark in Soviet modernist architecture and aesthetics, oriented at fostering the post-Stalin generation as the future inhabitants of communist society. Accordingly, the palace was built as a model for a future society with a harmonious material culture. Before my analysis of this vision, a brief explanation of the Pioneer Palaces (of which there were many) as an institution is in order.

Pioneer Palaces (or Pioneer Houses) were Soviet institutions, subordinate to the Ministry of Enlightenment in each Soviet republic and aimed at providing a well-rounded creative education for children and adolescents. Their programmes, which included a diverse set of activities from singing to aircraft modelling and from theatre to sports, were established and guided by the All-Union Lenin Communist Youth League or Komsomol. Pioneer Palaces were the headquarters of the Pioneer organisation that

emerged under the auspices of Komsomol in 1922 to prepare children from the ages of 10 to 15 to become proper Soviet citizens. The first Pioneer House opened in Moscow in 1922 and they spread throughout the USSR in the 1930s; by 1939 there were 852 in Soviet Russia alone.<sup>55</sup> Early Pioneer Houses were located in former aristocratic mansions, and those built in the 1930s often imitated classical models.

In 1958 the Komsomol Central Committee began to plan a new Pioneer Palace, which would be built from modern materials and be radically different from previous palaces. The chosen location, the Lenin Hills in the south-west of Moscow ('Sparrow Hills' before 1935), had traditionally been a popular leisure resort for Muscovites. Under Stalin, it gained importance as the location of the grandiose Moscow State University (MGU), one of the 'Seven Sisters' skyscrapers built between the late 1940s and the early 1950s as landmarks along with the never-realised Palace of Soviets. In the second half of the 1950s, Moscow's south-west region became a site of experiments in innovative urban planning and architecture, from the second project for the Palace of Soviets (also eventually abandoned) to the residential bloc of five-storey prefabricated buildings, the 'New Cheremushki'.<sup>56</sup> Accordingly, the Lenin Hills needed a new post-Stalin and 'post-excess' landmark, an architectural response to the MGU. In 1958 the Komsomol Central Committee and Moscow Party Committee announced a competition for the palace that would reflect the newest construction techniques as well as the Pioneer Palaces' task of building a future communist society. Unlike other Pioneer Palaces, it was not supposed to be one building but a whole complex of buildings, for which a 54-hectare plot in a park was assigned.<sup>57</sup>

The winners of the competition were a team of young architects from the construction institute Mosproekt: Viktor Egerev, Vladimir Kubasov, Feliks Novikov and their leader Igor' Pokrovskii. In resonance with contemporary tendencies in Western architecture and in contrast to the custom of the Stalin era, they suggested placing the building well within the plot rather than next to a street.<sup>58</sup> Their plan was for the palace complex to have one main, two-storey building with four perpendicularly attached wings. The main building was to be connected by a gallery to a concert hall. The main building and the concert hall would comprise an 'L' shape abutting the parade ground, where Pioneer ceremonies would take place. The plan also included several semi-enclosed outdoor spaces for various activities, which opened into the park where there would be recreational structures such as pavilions and artificial lakes. All the buildings were to be constructed using industrial methods from standard blocks of reinforced concrete.<sup>59</sup>

The project was further expanded with the help of the architects Boris Palui and Mikhail Khazhakian. It was envisaged as a crucial component of the new centrifugal city plan and an embodiment of the Khrushchevist



decentralisation of power, socialist democracy, and new optimism about scientific and technological progress. Egerev and his team employed the principles of free planning and functionalism,<sup>60</sup> characteristic of the architectural modernism of the 1920s–1930s, which now expressed the new Soviet ideals of the post-Stalin era. Thus, elements that were commonplace in Western architecture were reinterpreted on Soviet soil as innovative forces for the negation of Stalinist art deco and neoclassicism.

The palace's interiors also had to speak to the new direction of Soviet architecture. For this purpose, the construction team enlisted recent industrial art graduates from the Moscow Higher School of Art and Industry (MVKhPU). This decision was not accidental: the palace was designed by young architects (all, except for Khazhakian, younger than 40) for a young audience, the next generation of the Soviet people. Accordingly, the palace's interiors and environs would also be best designed by young people, who had started their design education in September 1954, only just before the famous anti-excess resolution, and who had generally not been exposed to Stalin-era aesthetic principles such as obligatory figurativeness, focus on subject matter and lush decoration. In addition, MVKhPU benefited from being involved in the palace's design because this suited the all-Union school reform, conducted by the Soviet government since 1958.<sup>61</sup> A part of this reform was the resolution 'On the forms and terms of education in higher institutions and the production internship of students', issued by the USSR Soviet of Ministers in August 1959.<sup>62</sup> In particular, it obliged full-time students of higher art schools to work as employees or paid interns in industrial enterprises for one year. The topics for graduation projects for the academic year 1959–60, given out by MVKhPU in September right after the issuing of the resolution, were all related to practical subjects – mass housing, public buildings, public transport and factory equipment. The projects for the palace's interior perfectly suited the Party-led campaign to update the architectural, social and cultural landscape of the Soviet capital city.

During the academic year, over thirty-three students were expected to design furniture, lamps, lattice screens, fountains, monument plaques, decorative sculptures and other types of decorative and utilitarian furnishings.<sup>63</sup> The students were granted access to workshops and had the technical assistance of the team of architects who designed the palace. In June 1960 the students presented their drawings and models to the State Examination Committee. The committee included the palace's architects Egerev, Kubasov and Khazhakian, as well as engineers Nikolai Maikov and Iakov Kerzon.

Several designs for the palace stemmed from the departments of metalworking and carpentry at the Faculty of Industrial Art, headed by architect and designer Aleksandr Korotkevich.<sup>64</sup> These two departments exemplified the continuity between the 1920s Russian avant-garde and

post-war Soviet design. They both incorporated woodworking and metalworking traditions from Vkhutemas and the teaching of such prominent instructors as Vladimir Tatlin, Aleksandr Rodchenko, El Lissitzky and Anton Lavinskii, who decisively broke with methods of traditional applied art and introduced advanced propaedeutic courses and technical disciplines. In 1926 the two departments were united into the department of carpentry and metalworking (known as *dermetfak*), which became the cradle of Soviet proto-design by training ‘the first detachment of qualified designers’, as Selim Khan-Magomedov phrases it.<sup>65</sup> In the late 1950s two of these pre-war graduates, Zakhar Bykov and Nikolai Sobolev (noted as being among Rodchenko’s best students by Varvara Stepanova in 1923),<sup>66</sup> headed the MVKhPU departments of metalworking and carpentry, respectively. Bykov was the school’s rector. Another *dermetfak* graduate, Boris Sokolov, taught in the carpentry department and supervised several graduation projects for the Pioneer Palace. What could their own students, intellectual ‘grandchildren’ of Rodchenko and other constructivists, offer for the crucial construction project of the Khrushchev era?

Furniture design was a particularly important point of continuity between Vkhutemas and MVKhPU. In the 1920s the ideal of asceticism in everyday life was generated both by economic necessity and by collectivist spirit, and projects for collapsible furniture were of equal interest for architects, designers and workers who inhabited rooms appropriated from the bourgeoisie and the newly built house-communes. Boris Arvatov celebrated collapsible furniture as an example of a new thing, ‘functional and active, connected like a co-worker with human practice’.<sup>67</sup> In accordance with the productivist image of socialist objects, students of *dermetfak* at Vkhutemas designed various types of collapsible furniture, mostly made of wood, but in some cases also with steel tubes. After graduating in the late 1920s, some of these ‘pioneers of Soviet design’<sup>68</sup> entered factories and influenced, though on quite a limited scale, Soviet furniture production.<sup>69</sup>

After the dominance of traditional furniture from the 1930s to the early 1950s, collapsible furniture again found state and Party support as a tool for modernising material culture. This time though, unlike in the 1920s, the industry had the capacity to produce such furniture on a mass scale. Thus, Arvatov’s ‘co-workers’ could now enter every Soviet home. Modernist public buildings such as the Pioneer Palace were supposed to display the best prototypes of mass-produced furniture. The three-decade-long interruption in furniture design education, however, meant that Soviet metal furniture was still, in the opinion of Khazhakian in 1960, ‘a lame-duck industry’ (*samyi otstaiushchii front*).<sup>70</sup> While assigning furniture designs to students, the palace’s architects also conducted research on the latest models of Finnish and Swedish furniture and as a result ordered 40 per cent of all of the palace’s furniture from Finland. They later regretted their decision when they saw the student projects, which far surpassed

their expectations. The architects decided that the student designs were of a high enough quality to equip the entire palace and were no worse than the Finnish furniture. The Soviet Union's lagging behind the West looked as if it was coming to end, at least in the field of furniture design.

In June 1960 both the carpentry and metalworking departments of MVKhPU presented metal furniture designs. Metalwork students combined metal frames with plastic and carpentry students combined them mostly with wood.<sup>71</sup> As a type of progressive furniture, invented and popularised by the Bauhaus student Marcel Breuer, tubular steel furniture appeared to be the most suitable for the new palace. This decision reflected a broader campaign for the updating of furniture production, begun by the Soviet government after 1958 in connection with the construction of mass housing and as a response to high demand.<sup>72</sup> The use of new technologies and materials, such as plastics and rubber foam, was promising as a way of overcoming the outdatedness of furniture production. This naturally necessitated new forms for the furniture itself. As architect N. Borushko expressed it in the summer of 1960, 'the established types of sideboards, cupboards, beds, etc., cease to be attractive not just because their size does not fit in contemporary flats, but also because outdated forms do not correspond to new aesthetic views'.<sup>73</sup> As such, the Pioneer Palace's furniture was the most convenient space to demonstrate cutting-edge Soviet designs, suitable for the more modern needs of the next generation.

When evaluating students' furniture projects, the term 'lightness' was often used by the examination committee. Outdoor furniture for the shore of an artificial lake in the palace's park was presented by its designer Igor Akimov as 'convenient, light and beautiful, and also easily collapsible, so it would last longer and be conveniently stored in winter'.<sup>74</sup> The furnishings for the waiting rooms, designed by Elena Bondarenko, would include convenient wooden chairs 'of a very light type'.<sup>75</sup> Valentin Konovalov's equipment for the concert hall was praised for the use of 'new progressive materials: thin-walled metal tubes in place of massive legs for chairs and foam rubber for seats instead of springs'.<sup>76</sup> For the kitchen of the palace's 'housekeeping school', the student E. Fomina designed functional and hygienic furniture arranged along the walls. Her reviewers found the design simple and convenient: the plastic coatings of work surfaces could be easily cleaned, while the central table had narrow metal legs that would appear light and evoke a sense of spaciousness.<sup>77</sup> Similarly, for the palace's park, Nodari Gogoberidze designed benches, chairs, tables and chaise-longues that were 'firm, light and easily transportable', easy to collapse, but also brightly coloured and reasonably cheap in terms of production costs.<sup>78</sup>

I suggest that 'lightness' here acted as a signifier of cutting-edge design, or what the philosopher Charles Peirce calls a 'qualisign'.<sup>79</sup> In her study of the material culture of socialist Hungary, anthropologist Krisztina

Fehérváry uses the concept of a *qualisign* to explore, within the framework of Peircean semiotics, the influence of materialities on the process of signification. As she explains, qualisigns are qualities that ‘can produce affective responses that may or may not come to constitute a recognizable aesthetic regime’. Textures, colours and properties, found in multiple objects, substances and bodies, have the potential to become qualisigns: ‘The qualia of grey in a rug, for example, is shared by a slab of concrete, a dawn fog, and pebbles on the lakeshore; this grey usually mingles with other material properties such as texture or fragility.’<sup>80</sup> According to Fehérváry, the presence of qualisigns allows diverse realms to be combined into a coherent style. Relying on this argument, one can suggest that post-Stalin ‘contemporary style’ was built upon the physical qualities of materials rather than a lexicon of figurative elements.

Lightness, therefore, acted as a crucial evaluation criterion and defined both the praise and criticism of post-Stalin Soviet designs. Two examples are particularly illustrative. First, the carpentry student M. Vlasov-Klimov was challenged with designing the palace’s dining hall, with space for 176 people and a passageway for a worker with a food-cart.<sup>81</sup> The task was further complicated by the unusual ellipsoid shape of the room, with a sail-shaped ceiling supported by a solid pillar in the centre, and a large glass wall that looked out on a stadium and pond. Vlasov-Klimov handled the task by designing small square tables, easily adjustable to the curve of the wall and to the position of the pillar. The tables were accompanied by light chairs of innovative construction: the seat and back were a single piece of bent nine-layer plywood, and the legs were two steel tubes that intersected at one point and were fixed to the seat. The tables would have two tops, the lower serving as a shelf for children’s possessions. The front surface of the chairs and the tops of the tables would be PVC and coated in a nitrocellulose lacquer. Vlasov-Klimov also presented models for a sharp-cornered collection table for dirty dishes and a complex buffet table, probably inspired by the late 1920s projects for kitchen units and transformable furniture. The buffet would include a table with two glass display cases, a cold-air unit and several shelves of adjustable height.

Nikolai Sobolev, a Vkhutemas graduate and the head of the carpentry department, found the table design uneconomical: ‘Why such effort just to support the tables? I calculated that you used [altogether] forty metres of excessive tubes, while we always use metal sparingly.’<sup>82</sup> Vlasov-Klimov defended his choice: the legs were fixed to the middle of a table top rather than its sides so that they would not disturb the legs of the sitters. Such a construction, though ergonomic, is not sufficiently stable and requires an additional fixing element – hence the use of extra tubes. Several committee members disapproved of the shape of the table for dirty dishes. Zakhar Bykov, another Vkhutemas graduate and head of the metalworking department, called it ‘accidental and unwarranted’ and, contrary to what

Vlasov-Klimov claimed, difficult to keep clean. In addition, Bykov and the engineer Nikolai Maikov criticised the pointed angles of the table top as ‘somewhat disturbing’ and suggested that rounded angles would be safer for children approaching the table with used dishes. Vlasov-Klimov explained that the sharp square form of the table top was determined by the parameters of the interior.

The quality of lightness, implied by tubular steel furniture, also appeared questionable: one committee member doubted that children would be able to move the chairs. Vlasov-Klimov again reassured his critics that the chairs were ‘very light’, and that their rubber ‘feet’ also made them more stable. These arguments revealed the contradictions between different principles of modernist design, embraced by Soviet architects and applied artists by 1960: economy, functionalism, ergonomics and ease of maintenance. While trying to follow some of these principles, Vlasov-Klimov unwittingly violated others. Square tables might be elegant but could also be potentially dangerous for their users. Formal considerations overshadowed ergonomic requirements. In the case of the tables’ legs, ergonomic considerations meant the overuse of production materials. These shortcomings were easily explicable in terms of the designer being a student who lacked experience. Yet they represent the contradictory legacy of Vkhutemas design that influenced Soviet design education in the late 1950s but was mostly untraceable in an everyday environment. The students needed to reconcile the requirements of aesthetic novelty, user-friendliness and economic efficiency.

The second example of lightness was the case of V. Goriunova, another student in the carpentry department, who designed furniture for a very spacious playroom for schoolchildren between the ages of 7 and 9 (*oktiabrita*), located in the main building of the palace in the winter garden.<sup>83</sup> Her work was influenced by the specific nature of the room’s walls: two walls were replaced by sliding glass doors, the third wall was made of wooden blocks and the fourth wall totally from glass; with opening side doors, the hall would be united with the main enfilade of the palace. In accordance with contemporary ideas on communist upbringing and educational space,<sup>84</sup> Goriunova was instructed to create a dynamic and interactive interior. The existing Soviet educational institutions did not provide her with proper models for emulation: ‘There was nothing to look at.’ Rejecting interiors that were familiar to her, Goriunova attempted to create a completely new arrangement of furniture, toys and wall decorations, where everything could be a tool for entertainment and education. She explained, ‘I aimed to create conditions for the children to feel free; to create a specific children’s world. Therefore, I proceeded from the principle of simple forms, accessible and amusing for children.’ She designed collapsible furniture that could be easily folded when the hall was in use and stored in the general enfilade. Using wooden pieces and foam-rubber

cushions, children could compose their own furniture, such as a table or couch. The toys were also designed to be collapsible and connectable. Architect Sergei Nikulin approvingly noted that both furniture and toys would stimulate children's creativity and interest in collective games, which would be 'correct in terms of the methodology of upbringing'. The sliding partition walls would be decorated with appliqué landscape compositions that would correlate thematically with the actual landscape visible through the glass wall. Presuming that an opaque wall would look boring, Goriunova decorated it with geometric patterns in mild colours. In all the decorations, she claimed to have relied 'on children's drawing and children's taste'. To make the children's play more comfortable she suggested covering the floor with a grass-like mat. Despite criticism that some toys' details could not be easily repaired if broken, her project generally met the expectations of the palace's architects.

Goriunova's approach to the playroom echoed the idea of playfulness that was prominent among post-war architects and designers in Europe and the US. As Sarah W. Goldhagen explains, an important component of this was the idea of *homo ludens*, human being at play, inspired by Johan Huizinga's 1938 book of the same name. Play, understood as the source of spontaneous self-expression and resistance to socio-political pressure, required proper architectural spaces. Accordingly, play often served as a reference point for architects, such as Alison and Peter Smithson and Cedric Price in Britain, Jaap Bakema and Aldo Van Eyck in the Netherlands and the members of the Situationist International in France, especially in the late 1950s.<sup>85</sup> Although Soviet architects and applied artists were concerned with facilitating collective leisure activities at that time, unrestricted playfulness was not considered to be a crucial part of human life. Childhood, however, was a prominent exception. The objects Goriunova designed were presented not as 'co-workers', like those designed by Rodchenko, but as toys or playmates. Goriunova's playroom, as well as the whole Pioneer Palace project, was envisioned as a segregated space of freedom within an otherwise regimented socialist society.

All the projects for the palace from the metalworking and carpentry departments – sixteen altogether – were expected to be implemented by the end of 1960. Khazhagian called for the finding of 'organising forms' for realising the projects in situ. 'It could be said that we are witnessing the birth of a great mastery', he mused.<sup>86</sup> Architect Georgii Zakharov, the pro-rector of MVKhPU, stated that the defining of these 'organising forms' should be the responsibility of the palace team and Komsomol as much as of the school.<sup>87</sup> However, cooperation between the palace's architects and the MVKhPU administration remained only at the level of good intentions. In April 1962, three months before the opening of the Pioneer Palace, the administration board of the Moscow Organisation of the USSR Union of Architects met with the MVKhPU representatives to discuss the students'

graduation projects and the prospects for their implementation into industry. At this meeting, rector Bykov complained that architects rarely turned to MVKhPU for help, and even if they did, the student works that came out of this were often neglected. He cited the Pioneer Palace as a vivid example: 'Unfortunately, none of the student projects has been realised, even though they all have been approved and the students strongly wished to implement them in situ.'<sup>88</sup> The available sources do not show that palace architects ever replied to this charge.

The palace was opened on 1 June 1962 on the International Day for the Protection of Children, with a grand ceremony. The book authored by the palace's architects, as well as archival sources, reveal that some of the MVKhPU projects were in fact implemented in modified forms without the involvement of the students or acknowledgement of their work. These sources, however, do not indicate the reason behind this decision of the architects (it was not a legal problem since student works were not protected by Soviet copyright law).<sup>89</sup> It is most likely that, while the students' ideas were indeed appreciated as relevant and innovative, the inclusion of students in the palace team long-term would have simply been too arduous organisationally and would have slowed down construction.

Vlasov-Klimov's suggestion of having square tables with thin metal legs was implemented in the end. As in his original design, the table tops were coated with white plastic and the chairs with red.<sup>90</sup> His idea of having chairs made from a single piece of bent plywood was rejected in favour of a more conventional chair with a metal frame. However, his chair design did appear in the buffet of the Pioneer Theatre, but it is likely that these were actually modelled on contemporary Nordic furniture rather than Vlasov-Klimov's design, given that some of the palace's furniture was produced at Finnish factories.<sup>91</sup> Indeed, Vlasov-Klimov himself could have very well imitated these same Finnish models. The rest of the furniture in the palace (Egerev does not specify the percentage) was designed by the Central Moscow Project and Construction Bureau of Moscow *sovmarkhoz* (TsMPKB), probably including the café's chairs, which clearly lacked the elegant simplicity of Finnish furniture. These chairs were obviously solid enough to withstand wear and tear from their young and hungry occupants, just as Vlasov-Klimov's chairs were supposed to do, but *en masse* they formed a rather chaotic assembly, a forest of metal legs, somewhat in discord with both the transparency of the café's wall and the sturdiness of its reinforced concrete support. Their slightly clumsy form would soon become ubiquitous throughout the USSR until the country's collapse, and the chairs remained in many public buildings, such as schools and cafeterias, well into the 1990s – obsolete, material signifiers of a past era.

V. Goriunova's project for the *oktiabriata* playroom was also partially modified. Reporting on the palace's opening, the official newspaper of the Komsomol paid special attention to this room:



All rights reserved and permission to use the figure must be obtained from the copyright holder.

### 1.1 Pioneer café interior in the Pioneer Palace on the Lenin Hills, 1961.

To the right [from the winter garden], behind the wall is a green lawn. This is the *oktiabriata* room. The floor is covered here by a thin carpet of soft plastics, and all the toys are on the floor. They are selected in such a way that one cannot play with them alone – only with peers.<sup>92</sup>

In his book, Egerev specified that the carpet was made from nylon, and the toys were ‘cars and cranes, construction equipment, rockets and ships, dolls and bricks – everything that can give joy to a child’.<sup>93</sup> The emphasis on joy, rather than prohibition and punishment, echoed Goriunova’s emphasis on entertainment and freedom of movement in her project. Indeed, two of her suggestions – the green, grass-like carpet and the dynamic toys – were incorporated by the architects in the actual room. However, instead of the sectional furniture in the original project, TsMPKB designed low tables with multagonal shapes. Although irregular and amusing, these tables were static props for children’s games rather than transformable objects/playmates. The decoration of the glass partitions, another of Goriunova’s suggestions, was also neglected in favour of transparency and, implicitly, easier control over the playing children. As a result, the actual playroom environment turned out to be more restrictive of children’s freedom than Goriunova’s design had intended.

While the story of the students’ painstaking work on designing the interior of the Pioneer Palace has been mostly forgotten, the building itself, on the contrary, has since become one of the main icons of Khrushchev-era Soviet modernism.<sup>94</sup> Enthusiastic reviewers praised the palace complex



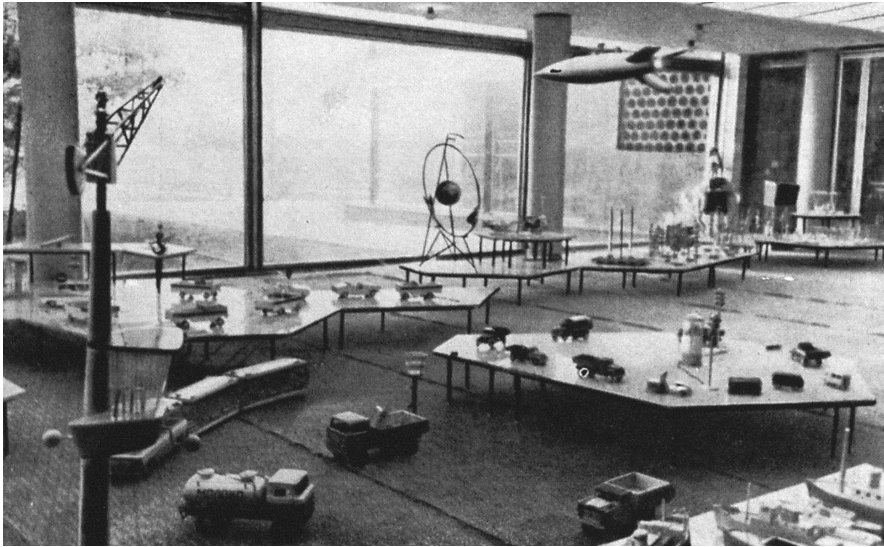

All rights reserved and permission to use the figure must be obtained from the copyright holder.

**1.2** Playroom for young children in the Pioneer Palace on the Lenin Hills, 1961.

with its numerous courtyards and artificial lake as a ‘country of romantics’. Professional critics believed it to be a breakthrough, or, as Lebedev phrased it, ‘a leap forward in the process of architectural development’.<sup>95</sup> In the eyes of its contemporaries, the Pioneer Palace came to signify the Soviet Union’s catching-up with modernity and an overcoming of its backwardness and its Stalinist past. The palace’s interior spaces, too, were perceived in that light. But behind this joyous image were clashing visions of what constituted modernity and functionality, of what was feasible and financially viable – visions held by different generations of designers and architects over what the future communist generation should be.

### Excess and taste

A 1964 film by Vasilii Shukshin called *There is Such a Lad (Zhivet takoi paren’)* has a memorable scene.<sup>96</sup> The main protagonist, the young truck driver Pashka (Pavel) Kolokolnikov, gives a lift to an educated woman from the city on a remote Siberian road. Pashka complains that country life is boring, and the woman answers that it is the villagers’ own fault, because they fail to make their lives ‘truly beautiful’. She additionally argues that the beauty is in the detail: ‘I have just been in the home of one young [female] collective farmer. She’s got all kinds of stuff! Pillows, bedside tables, stupid elephant figurines ... What do you think is it for? For “happiness”. You’re a young man – don’t you understand?’ On Pashka’s awkward attempt to defend domestic cosiness, she responds didactically:

Look, it is philistinism! Elementary philistinism. Incredible! Is it so difficult to replace all this with two or three reproductions of contemporary artworks, to have an ottoman instead of a merchant-style bed, to buy a floor lamp? By the way, lighting means a lot. To place a contemporary beautiful vase on the table. Is it really so hard? And such furnishings will be no more expensive [than the familiar ones]!

This passionate speech resonated with numerous articles on good taste that appeared in the Soviet press prior to the early 1960s. Obviously, the educated passenger is familiar with them. She has absorbed the expert discourse on good taste, and now acts as an agent of modernisation in the countryside. Her speech indeed affects the driver, an open-hearted country lad. The next shot captures Pashka's fantasy: a room arranged in a minimalist fashion, with modest furniture, window curtains with geometric patterns and a few reproductions on the walls, one of them even featuring abstract painting. This is a recognisable picture which one could have seen mirrored in *Dekorativnoe Iskusstvo SSSR*, *Tekhnicheskaiia Estetika* or even the popular magazine *Ogoniek*. A young woman in the latest dress, with a bubble haircut, welcomes Pashka in 'French' to his fantasy home. He appears as a caricature of himself, wearing a suit and a top hat, pretentiously imitating French speech.

The scene ironically reveals both the ubiquity of Soviet taste advice and its insensitivity to specific contexts, which led to superficiality and absurdity. However, did Soviet design professionals really believe, like Pashka, that the beauty of daily life is achieved by simply throwing out knick-knacks and getting a floor lamp? What was behind the post-Stalin dictatorship of taste?

Taste is a complex concept, laden with social, economic and political factors. For more than a century, taste has been discussed extensively by sociologists (and from the 1980s also by anthropologists) as not only a matter of aesthetics but also a powerful marker of social stratification and a tool for building symbolic hierarchies.<sup>97</sup> In his celebrated book, Pierre Bourdieu presented taste as a key component of *habitus* – the generative principle for social practices and simultaneously the system of their classification. He argued:

Taste, the propensity and capacity to appropriate (materially or symbolically) a given class of classified, classifying objects or practices, is the generative formula of life-style, a unitary set of distinctive preferences which express the same expressive intention in the specific logic of each of the symbolic sub-spaces, furniture, clothing, language, or body texts.<sup>98</sup>

In particular, Bourdieu emphasised that the tastes of dominant classes are largely built on restraint: 'It is well known that all dominant aesthetics set a high value on the virtues of sobriety, simplicity, economy of means, which are as much opposed to first-degree poverty and simplicity as to

the pomposity or affectation of the “half-educated”.<sup>99</sup> This dominant aesthetics is appropriated not only by the upper middle class, the possessors of economic capital, but also by middle-class intellectuals, for example secondary and higher education teachers, endowed with strong cultural capital but often with fewer economic resources.

Even though Bourdieu’s theory has been criticised as reductionist and applicable only to France, his understanding of the negation of the ‘vulgar’ as the act of social distinction accurately characterises the modernist stance against ornamentation. This modernist critique not only targets the pitfalls of mass production but also demonises the ‘uneducated public ... with too much money and no time, or with no money and no time’, as Nikolaus Pevsner phrased it in his famous history of modern architecture.<sup>100</sup> Taste, therefore, is never socially and politically innocent – it is intimately linked with social hierarchies and can be instrumentalised by intellectuals as a marker of their symbolic superiority over the ‘uneducated public’, or as a tool for radical criticism of mass culture stemming from capitalist economic conditions, as was done by Marxist thinkers from Theodor Adorno to Guy Debord.<sup>101</sup>

Under state socialism, such a class distinction as described by Bourdieu would be unthinkable. Several scholars have recently stressed a holistic understanding of culture, officially promoted in the Soviet Union from its beginning until perestroika. Instead of ‘high’ and ‘low’ or ‘mass’ and ‘elite’ cultures and diverse lifestyles, Soviet officials and professionals spoke of a universally popular and enlightening culture in which ballet, classic literature, film comedies and folk art were harmonically combined – ‘an anti-masscult culture for the masses’, in the apt words of Kristin Roth-Ey.<sup>102</sup> This implied a single universal taste. Yet the notion of a homogeneous culture was an ideological construct in Soviet society, which, as Stephen Lovell rightly notes, concealed various tensions and inequalities that never disappeared under socialism.<sup>103</sup> I suggest that taste, as it was configured in Soviet public and professional discourses, can be perceived as an unwitting acknowledgement and even barometer of these tensions.

In the 1920s taste was mostly portrayed in a negative way, as a hindrance to the rational reorganisation of social life in a post-revolutionary society. While in capitalist, French society, as Bourdieu suggests, tastes are justified through the refusal of other tastes and thus ‘tastes are perhaps first and foremost distastes’,<sup>104</sup> in Soviet society taste was often defined as an attribute of the defeated aristocracy and petite bourgeoisie. Accordingly, with the reappearance of the latter as *Nepmen* in the time of the New Economic Policy, taste became a characteristic of the class opponent for leftist intellectuals, especially the artists associated with Proletkult (an artistic organisation under the Commissariat of Enlightenment) and the journal *LEF*. In the new proletarian Soviet culture, taste had to be replaced

by a technical and utilitarian necessity; this stance was vividly expressed in the famous composition–construction debate at the Institute of Artistic Culture in January–March 1921. Osip Brik declared enthusiastically in 1923 that the constructivist artist Rodchenko was ‘revolutionising taste’,<sup>105</sup> while Arvatov portrayed taste in 1925 as an inherently bourgeois idea, a symptom of the alienation of consumption from production that would eventually be overcome in a proletarian society. In the broader socio-political context, taste appeared as a pejorative term in the state-supported campaign for the reorganisation of everyday life (*byt*) when the NEP was being curtailed and during the first Five-Year Plan. One of the strongest voices of this campaign, the newspaper *Komsomol’skaia Pravda* (the official print organ of the Communist Youth League), repeatedly urged its readers in 1928 to break ‘the dictatorship of the workshop of faience figurines’ and ‘summon bric-a-brac to public trial’.<sup>106</sup> Bad taste in home furnishing came to signify an alien class ideology.

As several recent studies have demonstrated, the 1930s, especially following the abolition of rationing in 1935, was a time when a specific Soviet consumer culture was formed that reflected the new social hierarchies of an allegedly classless society.<sup>107</sup> This new social order was disrupted by the dramatic experience of the Second World War, whose devastating impact was felt long after the official proclamation of victory. War trauma and exhaustion, as well as Soviet soldiers’ encounters with Central European countries during the offensive of 1944–45, prompted a desire for better living standards and even modest luxuries as justly earned by sacrifice.<sup>108</sup> Therefore, the painful process of post-war recovery and reconstruction was accompanied by the flourishing of the black market.<sup>109</sup> In these circumstances, taste emerged as both a resonance and instrument of social change: people often showed a penchant for material possessions – which became, as Vera Dunham famously argued, the prerogative and reward of the newly formed middle class.<sup>110</sup>

The social order was shaken again by the death of Stalin and Khrushchev’s denunciation of his ‘personality cult’ and abuses of power at the XXth Party Congress in 1956. Khrushchev’s reforms, most prominently the full-scale expansion of mass housing and the establishment of cultural exchange with the West, intensified industrialisation, scientific and technical progress and the dramatic growth of cities<sup>111</sup> and opened the door to the diversification of taste. Simultaneously, the campaign against architectural ‘excess’ brought strictures on domestic comfort and decoration, both in everyday life and in artistic production. In the case of everyday life, moving to a one-family, prefabricated flat from a communal one meant not only an advance in living standards but also the rejection of old beloved possessions, such as massive ornate furniture. Decorative artists could now use mass housing as an argument for their important status as creators of furnishings and arbiters of taste, but they also had to solve the

methodological puzzle of translating new principles of architecture into their profession.<sup>112</sup>

Since the aesthetic turn occurred largely as a result of architectural reform, the materials and designs of mass housing greatly influenced the idea of good socialist taste. I argue that honesty was a core value of this new taste. The advocates for the modernisation of Soviet architecture emphasised honesty as a positive value behind unadorned façades and industrial building methods. Applied artists, too, tended to view honesty as one of the main virtues that they should pursue in their work. While they did not always use the word ‘honesty’ (*pravdivost’* or *chestnuts’*), the theme of honesty as opposed to dishonesty (usually connected to pretension) ran through their professional discourse in the late 1950s and the early 1960s. This theme was expressed with different words, such as ‘clarity’, ‘harmony’ or the ‘accordance of form to material and function’. I suggest that, by appealing to honesty, design professionals were looking for a symbolic order that would unite art, industry and consumption in a way appropriate for a Soviet society overcoming the traumas of war and late Stalin-era oppression. At the decisive time of defining the future trajectory of decorative art, honesty emerged as the core of the socialist object, the basis for its symbolic meaning, utility and social impact. The notion of an ‘honest’ object can also be viewed in the context of the intelligentsia’s hunger for ‘objective truth’ and sincerity after Stalin’s death and especially after the XXth Party Congress.<sup>113</sup>

Criticism of excessive and pretentious ornamentation appeared in the Soviet press even before the official attack on architectural excess. In September 1954, the journal *Sovetskaia Torgovlia* (*Soviet Trade*) published an article by the art historian Aleksandr Saltykov, in which he explained to workers that a good commodity is ‘first of all convenient, solid and durable’. According to Saltykov, commodities that failed to meet this criterion had to be rejected as kitsch (*khaltura*) that ‘distorts people’s ideas of art and spoils the taste of broad masses’, and should be officially withdrawn from trade by the USSR Central Council of Producers’ Cooperatives.<sup>114</sup> In a 1955 article, already in tune with the changing policy of architecture and building, Saltykov promoted the idea of honesty, which was addressed to applied artists and the managers of artistic organisations. He argued that ‘artistry in decorative-applied art means first of all that the object clearly manifests its function by its appearance, being itself in form and material, and not imitating anything else’.<sup>115</sup> This article was an attempt to justify applied artists’ preference of form over decoration, which should not be mistaken for ‘bourgeois formalism’: form deserved attention as long as it was ‘honest’. Disregarding plain forms is an unfortunate mistake, Saltykov claimed, because ‘[t]he object itself must also be beautiful, its proportions, silhouette, and contours must be perfect, vibrant, emotionally saturated; its parts must constitute a well-rounded harmonic whole, simply

and clearly expressing its practical destination and fully corresponding to its material'.<sup>116</sup>

This article by Saltykov presented the first publicly available portrayal of the image of a socialist object. A socialist object should be well proportioned and clear, should not try to seduce its user but honestly declare the way that it was manufactured and the way it should be used. Saltykov's argument can be interpreted as the reinvigoration of the 1920s productivists' focus on construction, the necessary and sufficient basis of an artwork, rather than composition, an arbitrary and subjective arrangement of superfluous elements.<sup>117</sup> Design professionals in the 1950s demonstrated a similar strategy to that of the productivists: the belief in the honesty of the material as opposed to the changing 'Party line' and ideological pronouncements, the striving beyond ornamentalism towards the essence of things, towards the embodiment of the labour of an artist and a factory worker (who were, contrary to the productivist ideal, usually different people).

However, professional discussions and published texts of the 1950s betray a hesitancy to completely deny the 'mystery' of artistic creativity and, indeed, the importance of aesthetic appeal. To use the constructivist vocabulary again, the aesthetic turn was to a great extent organised around the fluctuation between 'composition' and 'construction'. For example, the glass artist and architect Boris Smirnov, at the theoretical conference at the Mukhina School in January 1954, argued that too much fixation upon functionalism leads to economic inefficiency, because ordinary Soviet people possess an inherent 'artistic sense' and expect a commodity to be first of all beautiful and only then convenient and durable.<sup>118</sup> Furthermore, according to Smirnov, the prevalence of constructive and 'functional-physiological' aspects was a feature of capitalist commodities, such as 'ultra-fashionable furniture'. One can read this as the reverse of the constructivist credo: exposed functionalism ('construction') as the source of commodity fetishism, and beauty ('composition') as the distinctive trait of a socialist object. However, design professionals, including Smirnov and Saltykov, undertook a more sophisticated attempt to draw the line between socialist honesty and dishonesty across the realms of function/construction and ornamental/aesthetic appeal. In search of appropriate criteria, they turned to folk art, which had been officially praised as an expression of truly popular creativity since the mid-1930s. In doing so, design professionals did not simply emulate the official rhetoric, but also followed the tradition of the professional study, preservation and promotion of peasant art. This stemmed from the late nineteenth-century patronage of artistic crafts and was gradually revived after the Revolution and the Civil War and again after the Second World War.<sup>119</sup>

A reference to folk art allowed not only functional structure and ornament to be reconciled ('construction' and 'composition') but also technical

skill and ‘artistic mystery’, which was positively reconceptualised as ‘fantasy’. Smirnov argued that fantasy, integral to everyday peasant life and art, serves for the development of a meaningful image, and so, say, an ornamental rooster is a means to provoke a festive mood and a signifier of certain typical features of peasant life.<sup>120</sup> Thus, an ornament was justified as an essential element of enjoyable labour and a source of the consumer’s positive emotions, and the ‘folk wisdom’, carefully mastered by professional applied artists, guaranteed the ornament’s ‘honesty’. In short, folk ornament was to be a measuring stick for an artist who struggled with the contradiction between pleasing the consumer and honestly revealing material and function.

Similarly, Saltykov, a connoisseur of folk art and ardent supporter of craft cooperatives in the traditional pottery region of Gzhel’, maintained that folk ornament is ‘deeply honest’ and has nothing to do with the ‘falsity and perversity of formalism’.<sup>121</sup> However, like Smirnov, he warned applied artists against the literal adoption of folk art models. In the autumn of 1955, reviewing an exhibition of applied art from the Baltic republics, Saltykov specified that contemporary artists should not mechanically copy the forms and ornaments of folk art, but should always carefully adapt them to their contemporary context. Forms, ornamental compositions and even colour schemes of certain objects can become obsolete and irrelevant. What the contemporary artist should take from folk art is the deep structural principle of the coherence of all parts and the subjection of form to function.<sup>122</sup> ‘Soviet artists must learn from the [village] folk to create simple and convenient things’, advised the art historian Nikita Voronov, the son of the prominent specialist on folk art Vasili Voronov (1887–1940), in a 1957 article in *Dekorativnoe Iskusstvo SSSR*. He believed that the heritage of peasant art should provide the solution of a ‘burning’ problem of expediency.<sup>123</sup> Among the objects illustrating this proposition was a ceramic fruit set by the artist M. Levina, produced at the faience factory in the Kalinin (now Tver) region through a combination of manual and machine techniques.<sup>124</sup> The set’s plate and saucer are decorated by the technique of free-flowing glaze, which produces different patterns on each particular object. Thus, the ornament is the explicit trace of the industrial process of glazing; it tells the story of labour invested in the product.

The key to the successful translation of folk art principles into mass production was often found in a ‘deep respect’ for the material.<sup>125</sup> Applied artists believed – or hoped – that material could not lie. ‘Considering the material as the means of embodying the ideal conception of the work, [an artist] should use its artistic and technological qualities to the utmost’, Smirnov argued. He added that each material possesses inherent decorative qualities. Using his favourite example, glass, he explained: ‘The main expressive qualities of glass [are achieved by] light: the refraction of light in facets; the condensation of light within glass; the free, almost unchang-

ing, passage of light through glass; and the colouring of light through glass by almost any colour.<sup>126</sup> Wood, textiles, ceramics, glass and plastics were expected to be treated skilfully, so that the best qualities of each material could be revealed.<sup>127</sup>

Plastic presents an especially interesting case of this line of thinking. As a new material, devoid of any history of artistic treatment, plastic provided a challenge to the decorative artist. In the same 1954 conference talk, Boris Smirnov suggested an approach to plastics that was at odds with the ideal of honesty. Since this material was still ‘in its infancy’, and its ‘expressive aesthetic qualities’ had not yet been found, it could be used as a cheaper replacement for gems, so beloved by Soviet people. One part of Smirnov’s argument for democratising good taste was that if gems were not available for mass production as commodities, their beauty should be reproduced in plastic. Was this a call for imitation and the deception of the consumer? By no means, Smirnov explained, suggesting ‘a sort of approximation of beautiful natural materials’.<sup>128</sup> He explained the difference:

If you thoroughly copy the structure, for example, of such a material as malachite, imitating the characteristic articulation of its pattern, produced by the technique of composition from different cut plates of a rock, then you get either a quite expensive museum copy, or in the case of bad-quality work, merely ersatz in the worst sense of the word. However, you can masterfully give new expression to a beautiful material, proceeding from the specific possibilities of plastic. Create a new, more or less similar, pattern, keeping the characteristic green colour, or probably even changing it. Create a new, not less beautiful red or blue ‘malachite’ – actually, ‘malachite’ only by association.<sup>129</sup>

The gem as a creative reference point rather than as a model for falsification was Smirnov’s peculiar scheme for what I would call ‘honest imitation’. An object made of ‘red malachite’ was not meant to fool the consumer but to make them appreciate the skill and creativity of its maker.

The actual production of plastic commodities was, however, a far sight from Smirnov’s ideal. In 1957 the Leningrad critic Virko Blek found that most plastic objects – such as baskets, plates and vases – produced by local industry were made with awful taste and overloaded with ornamentation. Blek argued that these plastics showed an extreme lack of respect for the material from which they were made. Unlike Smirnov, she urged artists to explore the inner qualities of this new medium: ‘Plastic is one of the most perfect materials, harbouring broad opportunities. And here one should predominantly operate with line, colour, strict and restrained forms. I believe that complex forms and ornamentation are not appropriate for plastics.’<sup>130</sup> At the conference on the ‘Problems of organising and maintaining the propaganda of visual arts in Leningrad’ in March 1959, the critic Moisei Kagan commented on this subject more sharply: ‘When [artists] try to hide the aesthetic qualities of new materials, being ashamed of these qualities, when these materials are used for faking traditional



and precious ones – gold or silver, velvet or marble – the result is sheer tastelessness in the sphere of applied art.’<sup>131</sup> His colleague B. A. Oleneva complained that objects that used to be produced from traditional materials look like cheap imitations when made from plastic. For this she blamed the directors of various small cooperatives (*arteli i artel’ki*) in addition to the lack of proper technical equipment for processing plastics.<sup>132</sup> Thus, ‘the age of plastics’, as Oleneva called her own time, made the task of producing ‘honest’ objects quite difficult. In the US and western Europe, plastic had acquired a dual reputation as both a super-modern material and an inferior substitute for more authentic materials by the 1960s. This was famously epitomised in popular culture by the film *The Graduate* (1967) and the song ‘Substitute’ by the rock band The Who.<sup>133</sup> Unsurprisingly, given that the Soviet Union emulated Western examples, plastic could hardly be a truthful material, despite artists’ and critics’ attempts to reveal its ‘hidden possibilities’. Yet these attempts, too, had Western precedents, which people such as Blek and Kagan might have well been aware of. For example, the Austrian-born British designer Gaby Schreiber had already argued in the early 1950s for the creation of new forms in plastic and against the simple imitation of the forms of traditional materials such as clay and metal.<sup>134</sup> An even closer example for Soviet designers to emulate was the state-sponsored development of high-quality, plastic household goods in East Germany (which are often still remembered as symbols of German socialist consumer culture).<sup>135</sup>

From professional discussions and articles in *Dekorativnoe Iskusstvo SSSR*, the theme of honesty spread into popular advice literature. This theme was considered in a peculiar way in a 1960 book by the prominent art historian Nina Dmitrieva entitled *On Beauty*. The book presented a comprehensive explanation of Soviet aesthetics of that era and its practical applications.<sup>136</sup> Dmitrieva insisted that the home of a modern person should be free of all things false and pretentious: no chairs where you cannot sit, no plates and dishes from which you never eat, no vases in which you cannot place flowers. Objects’ functions should not just be honestly expressed but also fulfilled. This position recalls a recent argument made by the art critic Ekaterina Degot’ regarding the ‘non-market’ aesthetics of Soviet goods. For Degot’, ‘Soviet things – in their ideal, rarely fulfilled variant – resist the aesthetics of “market appearance” and proceed straight to the essence of function: thick trousers make you warm, pasta feeds you, anti-aircraft machine guns shoot’.<sup>137</sup> However, if the ‘unfashionable’ and ‘formless’ objects that Degot’ describes filled Soviet flats and still constitute part of post-Soviet collective memory of Soviet everyday life, they were not the ideal to which the 1950s design professionals aspired. Like many of her colleagues, Dmitrieva advocated a beauty that was understood as essential rather than superfluous. ‘Everywhere in the domestic environment, beauty is inseparable from expediency’, she main-

tained. Functionality, expressed in an efficient material form, which corresponded to contemporary visual language, constituted the 'non-market aesthetics' of Soviet objects in the late 1950s and early 1960s, not formlessness or awkwardness. In her advice, Dmitrieva endowed Soviet objects with moral, human characteristics *and also* with visual appeal: you do not have to 'struggle' or conflict with them; they do not 'oppress' you, but predict your 'wishes and needs'.<sup>138</sup> Evidently, Dmitrieva understood these 'wishes and needs' as authentic and not imposed by any external force, and therefore easily met by simple, beautiful and useful goods.

Thus, the 'honest' socialist object was imagined at the intersection between functionalism and ornamentation, beauty and utility, artists' aesthetic principles and consumers' preferences. Indeed, who would prefer dishonesty over honesty, especially if, as Smirnov, Dmitrieva and others believed, urban consumers were predisposed to honest beauty just like peasant craftspeople? The Soviet consumer was imagined as the designer's ally in the battle for good taste against the agents of dishonesty and kitsch – undereducated managers of factories and craft cooperatives, narrow-minded trade workers and the philistine instructors of amateur craft-making circles.<sup>139</sup> This idealistic view culminated in the all-Union exhibition 'Art into Life' (*Iskusstvo v byt*) in April–June 1961. The event was sponsored by the Soviet Ministry of Culture, the Academy of Arts and the Unions of Artists and Architects and held in the Moscow Central Exhibition Hall (Manege). The exhibition aimed to showcase the best models of household goods for mass production – from furniture to glass – produced at factories across the Soviet Union, as well as model interiors for prefabricated flats. Design professionals optimistically viewed it as the beginning of a radical transformation of the mass production of household goods and the enhancement of their role as advisors to industry and arbiters of public taste. The scope, diversity and quality of the exhibits signified the triumph of art that was oriented towards mass production and the satisfaction of consumer needs. One reviewer enthusiastically noted that 'simple household objects' were exhibited alongside objects traditionally ascribed to applied art (such as porcelain cups or glass vases).<sup>140</sup> Aluminium and enamelled kitchenware produced at two Leningrad factories<sup>141</sup> was juxtaposed with a modestly decorated porcelain tea set from the Leningrad Porcelain Factory as embodiments of honest artistic labour. Glassware from Moscow and Moscow oblast, Leningrad and Byarozowka (Belarus), and highly praised Lithuanian furniture were perhaps the most obviously 'honest' items on display, as the light that played through the glass (as discussed by Smirnov) and the texture and structure of the bare wood produced a strong aesthetic effect. Above all, the exhibition was arranged in an 'honest' way: the designers A. Vilup and M. Plees were complimented for achieving 'maximal simplicity and clarity' and the avoidance of 'spectacular techniques' and 'deliberate embellishment'.<sup>142</sup>



All rights reserved and permission to use the figure must be obtained from the copyright holder.

### 1.3 Kitchenware, before 1961.

For the agents of the aesthetic turn, the exhibition was evidence that the Soviet artist was becoming fully integrated into industrial production and that art and everyday life were becoming unified. The choice of a productivist slogan as the title for the exhibition was no coincidence. The exhibition manifested the concept of Soviet design-as-practice (*khudozhestvennoe konstruirovaniie*, ‘artistic engineering’) and its profound impact upon applied art in terms of the relation to industry. As the applied artist I. Chizhova commented seven years later, ‘it seemed that the paths of *khudozhestvennoe konstruirovaniie* and applied art are converging, and this is the only possible way to further the creation of objects for people, first and foremost, rational in form, convenient and beautiful’.<sup>143</sup> However, as viewers and design professionals themselves complained, the majority of the exhibits were still unique objects rather than samples of already mass-produced goods.<sup>144</sup> While a newsreel about the exhibition in 1962 presented the visitors’ criticisms as minor and stemming from a general curiosity and excitement with the new,<sup>145</sup> the responses in guest books, as Susan Reid demonstrated in her study,<sup>146</sup> were far from uniformly enthusiastic. Evidently, taste hierarchies as imagined by design professionals (socialist honesty vs. petty-bourgeois excess and/or capitalist ultra-fashionable functionalism) could hardly reflect social reality.

## Conclusion

This chapter has offered a view of post-war Soviet design in a broad sense, not reducible to genealogies of institutions, biographies of professionals, or a stylistic evolution from socialist realism to socialist modernism. It

mapped the space of numerous ideas, activities and objects. Or, to use the terms of Régis Debray,<sup>147</sup> it analysed the ‘mediological’ basis for different creative activities that intensified, or emerged, after Stalin’s death. The development of each of the three major aesthetic categories – (socialist) realism, contemporaneity and taste – followed a similar path from a cautious evasion of the orthodoxies set by easel art through the appeal to folk tradition, to a decisive embrace of functionalism stimulated by unprecedented architectural reform. By the early 1960s, the time of the institutionalisation of industrial design, design professionals had developed a number of visions of and requirements for socialist objects that often conflicted. A vibrant, up-to-date and honest object was to become a strong material argument for the advantages of state socialism. The following chapters consider the practical attempts to make socialism tangible and enjoyable.

## Notes

- 1 ‘Da zdravstvuet slavnoe 50-letie Velikoi Oktiabr’skoi sotsialisticheskoi revoliutsii!’, *Dekrativnoe Iskusstvo SSSR* 10 (1967), 1–2.
- 2 *Pulegoso* (from the Italian dialect word *pulega*, ‘bubble’) refers to glass containing numerous bubbles of various sizes, produced by adding bicarbonate of soda, gasoline or other substances to the melt. The technique was elaborated in the late 1920s at Murano by designer and businessman Napoleone Martinuzzi. The irregular texture of the glass produced by the bubbles resonated with Soviet glass artists’ experimentation with textures in the 1960s; hence the popularity of *pulegoso* in the Soviet Union.
- 3 Jacques Rancière, ‘Foreword’, in *The Politics of Aesthetics: The Distribution of the Sensible* (London: Continuum, 2006), p. 10.
- 4 Jacques Rancière, ‘Artistic Regimes and the Shortcomings of the Notion of Modernity’, in *The Politics of Aesthetics*, p. 21.
- 5 Boris Groys, *The Total Art of Stalinism: Avant-garde, Aesthetic Dictatorship, and Beyond* (Princeton, NJ: Princeton University Press, 1992).
- 6 Matthew Cullerne Bown, *Socialist Realist Painting* (New Haven, CT: Yale University Press, 1998).
- 7 On Deyneka, see Bown, *Socialist Realist Painting*; Christina Kiaer, ‘Was Socialist Realism Forced Labour? The Case of Alexander Deineka in the 1930s’, *Oxford Art Journal* 28.3 (2005), 321–45, doi:10.1093/oxartj/kci031. On Laktionov, see Susan E. Reid, ‘Modernizing Socialist Realism in the Khrushchev Thaw: The Struggle for a “Contemporary Style” in Soviet Art’, in Polly Jones (ed.), *The Dilemmas of De-Stalinization: Negotiating Cultural and Social Change in the Khrushchev Era* (London: Routledge, 2006), pp. 209–30.
- 8 From Andrei Zhdanov’s formulation at the First All-Union Congress of Soviet Writers in August 1934. ‘Pervyi Vsesoiuznyi S’ezd sovetsskikh pisatelei. Stenograficheskii otchet’ (Moscow, 1934), p. 175. Quoted in Igor Golomshtok, *Totalitarnoe iskusstvo* (Moscow: Gallart, 1994), p. 86.
- 9 Reid, ‘Khrushchev Modern’.
- 10 TsGALI SPb, f. 78, op. 4, d. 533, l. 5.
- 11 For extensive historical analysis of the role of materiality and symbolism of glass in Russian culture, see Julia Bekman Chadaga, *Optical Play: Glass, Vision, and Spectacle in Russian Culture* (Evanston, IL: Northwestern University Press, 2014).
- 12 TsGALI SPb, f. 78, op. 4, d.533, l. 5.

- 13 Aleksandr Saltykov, 'Voprosy razvitiia dekorativno-prikladnogo iskusstva', *Iskusstvo* 2 (1955), 30.
- 14 *Ibid.*, 31.
- 15 Moisei Kagan, 'O spetsifike i sushchnosti prikladnogo iskusstva', *Iskusstvo* 1 (1956), 16–21.
- 16 Kagan, 'O spetsifike i sushchnosti', 17–18.
- 17 TsGALI SPb, f. 78, op. 4, d. 390, l. 14.
- 18 TsGALI SPb, f. 78, op. 4, d. 390, ll. 22–9.
- 19 TsGALI SPb, f. 78, op. 4, d. 390, l. 32.
- 20 TsGALI SPb, f. 78, op. 4, d. 390, l. 90.
- 21 TsGALI SPb, f. 78, op. 4, d. 390, l. 107.
- 22 Here Chekalov demonstrates the very 'terminological confusion' that so upset Kagan: he uses 'decorative' and 'applied' interchangeably.
- 23 RGALI, f. 2943, op. 1, d. 2550, l. 2.
- 24 RGALI, f. 2943, op. 1, d. 2550, l. 4.
- 25 RGALI, f. 2943, op. 1, d. 2550, l. 3.
- 26 For example, 'Sovetskoe izobrazitel'noe iskusstvo v 1952 godu. O Vsesoiuznoi khudozhestvennoi vystavke', *Iskusstvo* 1 (1953), 3–4; TsGALI SPb, f. 78, op. 4, d. 435.
- 27 RGALI, f. 2943, op. 1, d. 2550, l. 5.
- 28 RGALI, f. 2943, op. 1, d. 2550, ll. 5–6.
- 29 Karl Marx, *Writings of the Young Marx on Philosophy and Society* (Indianapolis, IN: Hackett Publishing, 1997), p. 293.
- 30 RGALI, f. 2943, op. 1, d. 2550, l. 8.
- 31 RGALI, f. 2943, op. 1, d. 2550, l. 9.
- 32 RGALI, f. 2943, op. 1, d. 2550, l. 19.
- 33 RGALI, f. 2943, op. 1, d. 2550, l. 21.
- 34 RGALI, f. 2943, op. 1, d. 2550, ll. 14–15
- 35 Nikolai Punin, 'Pamiatnik III Internatsionala', in Irina Punina and Vasilii Rakitin (eds), *Nikolai Punin. O Tatline* (Moscow: RA, 1994), p. 20.
- 36 In light of the resonances with Wilhelm Röntgen's experiments in Russia, the iron frame could be associated with the skeleton. As Olga Matich and John E. Bowlt argue, 'the artists of the avant-garde were fascinated to discover mechanical parallels between zoological structures made clear with the X-ray and the industrial frames of the new iron buildings towering above Moscow and St. Petersburg'. John E. Bowlt and Olga Matich, 'Introduction', in John E. Bowlt and Olga Matich (eds), *Laboratory of Dreams: The Russian Avant-garde and Cultural Experiment* (Stanford, CA: Stanford University Press, 1996), p. 12.
- 37 RGALI, f. 2943, op. 1, d. 2550, l. 10.
- 38 RGALI, f. 2943, op. 1, d. 2550, l. 28.
- 39 RGALI, f. 2943, op. 1, d. 2550, l. 30–1.
- 40 Susan E. Reid, 'Art of Socialist Countries, Moscow 1958–59, and the Contemporary Style of Painting', in Susan E. Reid and David Crowley (eds), *Style and Socialism: Modernity and Material Culture in Post-War Eastern Europe* (Oxford: Berg, 2000), pp. 101–32.
- 41 RGALI, f. 2943, op. 1, d. 2550, ll. 45–7. Nazarevskaya's creative biography is discussed in Maria Blumin, 'Vliianie iskusstva avangarda na ornamental'nye motivy tkanei 1910-kh–1939-kh godov: na promere stran Zapadnoi Evropy i Rossii', PhD dissertation, St Petersburg State Academy of Art and Industry, 2006; summary available at [www.dissercat.com/content/vliyanie-iskusstva-avangarda-na-ornamentalnye-motivy-tkanei-1910-1930-kh-godov-na-primere-st](http://www.dissercat.com/content/vliyanie-iskusstva-avangarda-na-ornamentalnye-motivy-tkanei-1910-1930-kh-godov-na-primere-st), (accessed 8 November 2011).
- 42 RGALI, f. 2943, op. 1, d. 2550, l. 57.
- 43 RGALI, f. 2943, op. 1, d. 2550, l. 78.

- 44 Bennett, *Vibrant Matter*.
- 45 The exhibition was co-curated by Jane Pavitt and David Crowley. According to Pavitt, it was quite difficult to convince the administration of the V&A to open the exhibition with such a provocative title (Jane Pavitt, 'Cold War Modern: Design 1945–70', public lecture, Open Society Archives, Budapest, 4 October 2013). See the catalogue of the exhibition: David Crowley and Jane Pavitt (eds), *Cold War Modern: Design 1945–70* (London: V&A Publishing, 2008).
- 46 Reid, 'Khrushchev Modern'.
- 47 This understanding appears, more or less explicitly, in the work of many critics and scholars of the twentieth century, most famously Walter Benjamin. On modernism's critical aspect as related to material culture, see Brown, *Things*.
- 48 Tom Cubbin, 'From Technocracy to Techno-Utopia: Futurology and the Soviet Home at VNIITE, 1964–1974', MA dissertation, Royal College of Arts, 2012.
- 49 Brown, *Things*, p. 16.
- 50 *Ibid.*, p. 15.
- 51 Notably, Brown considers Constructivism and Surrealism as two conscious attempts 'to achieve greater intimacy with things and to exert a different determination for them'. Brown, *Things*, p. 11.
- 52 Arvatov, 'Byt i kul'tura veshchi', pp. 72–5. Quotes are taken from Christina Kiaer's translation: Boris Arvatov and Christina Kiaer, 'Everyday Life and the Culture of the Thing (Toward the Formulation of the Question)', *October* 81 (1997), 119–28, doi:10.2307/779022.
- 53 Arvatov and Kiaer, 'Everyday Life and the Culture of the Thing', 126.
- 54 The concern with the affective components of objects, characteristic of Arvatov's theory and of the Russian avant-garde in general, was taken by Sergei Oushakine as the starting point for a new scholarly trend, which he calls 'the materiology of emotions'. The landmark event for this trend was the interdisciplinary conference 'Objects of Affection: Towards the Materiology of Emotions', Princeton University, 4–6 May 2012, <http://objectsofaffection.wordpress.com/about/>. Selected presentations from this conference constituted a section of Russian scholarly journal *New Literary Observer* in 2013. See Oushakine, 'Dinamiziruiushchaia veshch'.
- 55 M. V. Fokina et al. (eds), *Stranitsy istorii iunyh lenintsev (materialy dlia besed)* (Moscow: Kniga po trebovaniuu, 1976), pp. 71–2.
- 56 Bocharnikova, 'Inventing Socialist Modern', pp. 115–54, 198–205.
- 57 Susan E. Reid, 'Khrushchev's Children Paradise: The Pioneer Palace, Moscow, 1958–62', in David Crowley and Susan E. Reid, *Socialist Spaces: Sites of Everyday Life in the Eastern Bloc* (Oxford: Bloomsbury, 2002), pp. 154–6.
- 58 Sarah Williams Goldhagen and Rejean Legault, 'Introduction: Critical Themes of Postwar Modernism', in Sarah Williams Goldhagen and Rejean Legault (eds), *Anxious Modernisms: Experimentation in Postwar Architectural Culture* (Cambridge, MA: MIT Press, 2001), p. 22.
- 59 Viktor Egerev et al., *Moskovskii dvorets pionerov* (Moscow: Izdatel'stvo literatury po stroitel'stvu, 1964), pp. 5–19.
- 60 It should be noted that attitudes to functionalism differed among the architects of the modern movement, and not all of them even had functionalist intentions. See Stanford Anderson, 'The Fiction of Function', *Assemblage* 2 (1987), 18, doi:10.2307/3171086.
- 61 On 24 December 1958 the Supreme Soviet of the USSR accepted a statute 'On Strengthening the Connection of School with Life and Further Development of the System of People's Education', aimed at global-scale training of technically competent personnel for industry and agriculture. According to this, only eight years of secondary school education were mandatory, after which students could either enter vocational schools or study for three more years in high school, where two days a week would be scheduled for internship at industrial or agricultural

- enterprises. School graduates received a certificate of technical proficiency. 'Ob ukрупnenii sviazi shkoly s zhisniu i dal'neishem razvitiu sistemy narodnogo obrazovaniia', in A. A. Abakumov et al. (eds), *Narodnoe obrazovaniie v SSSR. Obshcheobrazovatel'naia shkola. Sbornik dokumentov. 1917–1973* (Moscow: Pedagogika, 1974), pp. 53–61. The lack of positions for school interns in industry impeded the successful realisation of this reform, and in the mid-1960s it was curtailed. 'Printiat zakon "Ob ukрупnenii sviazi shkoly s zhisniu i dal'neishem razvitiu sistemy narodnogo obrazovaniia"', the website of the B. N. Eltsin Presidential Library, [www.prlib.ru/History/Pages/Item.aspx?itemid=365](http://www.prlib.ru/History/Pages/Item.aspx?itemid=365) (accessed 18 December 2014). For a detailed account of Khrushchev's educational reform, see Laurent Caumel, 'The Scientist, the Pedagogue and the Party Official: Interest Groups, Public Opinion and Decision-Making in the 1958 Education Reform', in Ilic and Smith (eds), *Soviet State and Society under Nikita Khrushchev*, pp. 66–85.
- 62 'O formakh i srokakh obuchenii v vysshykh uchebnykh zavedeniakh i o proizvodstvennoi praktike studentov', resolution by the USSR Council of Ministers, 4 August 1959, <http://base.consultant.ru/cons/cgi/online.cgi?req=doc;base=ESU;n=9934> (accessed 18 November 2014).
- 63 RGALI, f. 2466 op. 2 d. 137, l. 12.
- 64 RGALI, f. 2460, op. 2, d. 1167; RGALI, f. 2460, op. 2, d. 1168. According to this source, out of thirty-four diploma works defended in June 1960 by students of the metalwork section, five were dedicated to the palace. In the carpentry section, the percentage was even higher: eleven of twenty-one.
- 65 Khan-Magomedov, *Pionery sovetskogo dizaina*, p. 366. Khan-Magomedov argues that the department of carpentry and metalwork most fully responded to the initial programme of Vkhutemas that was stated in the decree by the Council of People's Commissars from 25 December 1920. This programme aimed, essentially, at educating specialists to raise the quality of the industrial production of useful objects. The text of the decree was published in *Izvestiia*, 25 December 1920, p. 1.
- 66 Varst (Vasvara Stepanova), 'O rabotakh konstruktivistskoi molodezhi', *LEF* 3 (1923), 53.
- 67 Arvatov and Kiaer, 'Everyday Life and the Culture of the Thing', 126.
- 68 This is the term used by Selim Khan-Magomedov as the title of his seminal 1995 book, with a clear allusion to Nikolaus Pevsner's famous work *Pioneers of the Modern Movement: From William Morris to Walter Gropius* (London: Faber & Faber, 1936).
- 69 A. Abramova, 'Naslediie Vkhutemasa', *Dekorativnoe Iskusstvo SSSR* 4 (1964), 8–12; Khan-Magomedov, *Pionery sovetskogo dizaina*, pp. 383–99.
- 70 RGALI, f. 2460, op. 2, d. 1167, l. 131.
- 71 Students of both departments in many cases designed similar objects – furniture – and worked with similar materials – tubular steel, plastic and wood in different combination. This reveals the problematic nature of institutional division according to the materials processed rather than the products designed. The necessity of uniting industrial designers in one section, distinguishing them from sculptors and decorators working with similar materials, would soon be realised at the governmental level. This problem was realised by the MVKhPU administration in the 1960s, and during this decade the disciplinary division was several times restructured. In particular, in 1965 the carpentry section was transformed into the department of furniture and transferred into the department of interior and equipment, while a special section for 'artistic engineering' (the term used for industrial design) was organised on the basis of the metalwork section. RGALI, f. 2460, introduction to op. 2.
- 72 Harris, *Communism on Tomorrow Street*, pp. 231–7.
- 73 N. Orieva, 'Krasota truda', *Tekhnika – Molodezhi* 7 (1960), 4. On the criticism of old furniture types, see V. Dele, 'O sovremennot mebeli', *Dekorativnoe Iskusstvo SSSR* 5 (1958), 28–32.

- 74 RGALI, f. 2460, op. 2, d. 1168, ll. 127–33.
- 75 RGALI, f. 2460, op. 2, d. 1168, ll. 46–53.
- 76 RGALI, f. 2460, op. 2, d. 1168, l. 125.
- 77 RGALI, f. 2460, op. 2, d. 1168, ll. 36–44.
- 78 RGALI, f. 2460, op. 2, d. 1168, ll. 231–3.
- 79 Charles S. Peirce, *The Philosophy of Peirce: Selected Writings* (London: Routledge and Kegan Paul, 1950), pp. 101–15.
- 80 Krisztina Fehérváry, *Politics in Color and Concrete: Socialist Materialities and the Middle Class in Hungary* (Bloomington, IN: Indiana University Press, 2013), pp. 7–8.
- 81 RGALI, f. 2460, op. 2, d. 1168, ll. 89–91.
- 82 RGALI, f. 2460, op. 2, d. 1168, l. 92.
- 83 RGALI, f. 2460, op. 2, d. 1168, ll. 198–206.
- 84 E. Koridalina, ‘Oni zdes’ khoziaeva’, *Semia i shkola* 4 (1962), 9–10; Reid, ‘Khrushchev’s Children Paradise’.
- 85 Goldhagen and Legault, ‘Introduction’, p. 19. Several essays from this volume deal specifically with the theme of *homo ludens* as related to architecture.
- 86 RGALI, f. 2460, op. 2, d. 1167, l. 131
- 87 RGALI, f. 2460, op. 2, d. 1168, l. 160.
- 88 RGALI, f. 2466, op. 2, d. 137.
- 89 In 1960 there was no special law concerning industrial standards in the USSR. The 1924 resolution of the Central Executive Committee and the Council of People’s Commissars ‘On industrial standards’ (drawings and models) was invalidated in 1936. No replacement document was issued. Technical drawings were now protected by copyright law, while models (prototypes) fell under the category ‘technical improvements’ and were protected by the 1931 regulation on inventions and technical improvements, according to which ‘author licence’, rather than patents, became the main form of protecting the rights of inventors. Evidently, student projects, drawings as well as models, were not considered as belonging to either of these categories, because they were ultimately not admitted into industrial production and thus not given author licences. A. P. Sergeev, *Pravo intelektual’noi sobstvennosti v Rossiiskoi Federatsii* (Moscow: Prospekt, 2003), pp. 34–48.
- 90 Egerev et al., *Moskovskii dvorets pionerov*, p. 35.
- 91 *Ibid.*, p. 94.
- 92 E. Brusikova and S. Soloveichik, ‘Kliuch ot strany romantikov’, *Komsomol’skaia Pravda*, 2 June 1962, pp. 1–2. Notably, one of the article’s authors, Simon Soloveichik, initiated the liberal trend in upbringing, based on tolerance to children’s initiative. See Catriona Kelly, *Children’s World: Growing Up in Russia, 1890–1991* (New Haven, CT: Yale University Press, 2007), p. 388.
- 93 Egerev et al., *Moskovskii dvorets pionerov*, p. 32.
- 94 On the attitude of architectural experts and the broader educated public in Russia to this building today, see ‘Arkhitektura ot Stalina do Khrushcheva’; ‘Iurii Bolotov – o tom, pochemu Dvorets Pionerov – samoe luchshee mesto v Moskve’, 16 November 2014, [www.the-village.ru/village/city/modern-architecture/169531-dvorets-pionerov-na-vorobievyh](http://www.the-village.ru/village/city/modern-architecture/169531-dvorets-pionerov-na-vorobievyh) (accessed 18 November 2014).
- 95 RGALI, f. 2943, op. 2, d. 82, l. 6.
- 96 Vasili Shukshin, *Zhivet takoi paren’* (Kinosdudiia imeni M. Gor’kogo, 1962), [www.youtube.com/watch?v=mGLgp6AP1gQ](http://www.youtube.com/watch?v=mGLgp6AP1gQ) (accessed 31 May 2014). The role of Pashka was played by Leonid Kuravlev.
- 97 This understanding of taste is mostly associated with *fin-de-siècle* studies by two prominent sociologists: the American Thorstein Veblen and the German Georg Simmel. See, for example, Donald N. Levine (ed.), *Georg Simmel on Individuality and Social Forms* (Chicago: University of Chicago Press, 1972); Thorstein Veblen and C. Wright Mills, *The Theory of the Leisure Class* (New Brunswick, NJ: Transaction



Publishers, 1992). The theme of taste, along with manners, was famously treated in 1939 by the German sociologist Norbert Elias in his seminal book on the cultural and political development of European society, later published in English as *The Civilizing Process: The History of Manners* (New York: Urizen Books, 1978). Taste prominently appeared in post-war American sociology as an element of consumption and mass culture; see particularly David Riesman, *The Lonely Crowd: A Study of the Changing American Character* (New York: Doubleday, 1953); Herbert J. Gans, *Popular Culture and High Culture: An Analysis and Evaluation of Taste* (New York: Basic Books, 1999). A classic sociological study of taste is the 1979 book by Pierre Bourdieu, *Distinction: A Social Critique of the Judgement of Taste* (London: Routledge, 1992), which, though confined to the specificities of French society, became a theoretical inspiration for a number of studies. In particular, Bourdieu's vision of taste as a manifestation of class distinction was drawn on and also criticised in the 1980s and 1990s by anthropologists concerned with material culture and consumption: Miller, *Material Culture and Mass Consumption*, pp. 147–217, 106–25.

- 98 Bourdieu, *Distinction*, p. 173.  
 99 *Ibid.*, p. 227.  
 100 Pevsner, *Pioneers of Modern Design*, p. 21.  
 101 Max Horkheimer and Theodor W. Adorno, 'The Culture Industry: Enlightenment as Mass Deception', in Max Horkheimer and Theodor W. Adorno, *Dialectic of Enlightenment: Philosophical Fragments* (Stanford, CA: Stanford University Press, 2002), pp. 94–136; Guy Debord, *The Society of the Spectacle* (New York: Zone Books, 1995).  
 102 Kristin Roth-Ey, *Moscow Prime Time: How the Soviet Union Built the Media Empire That Lost the Cultural Cold War* (Ithaca, NY: Cornell University Press, 2011), p. 2.  
 103 Stephen Lovell, *The Russian Reading Revolution: Print Culture in the Soviet and Post-Soviet Eras* (Basingstoke: Macmillan, 2000), pp. 15–21.  
 104 Bourdieu, *Distinction*, p. 56.  
 105 Osip Brik, 'V Proizvodstvo!', *LEF* 1 (1923), 105.  
 106 *Komsomol'skaia Pravda*, 4 November 1928, quoted in Svetlana Boym, *Common Places: Mythologies of Everyday Life in Russia* (Cambridge, MA: Harvard University Press, 1994). The quotation is translated by Boym.  
 107 Gronow, *Caviar with Champagne*; Hessler, *A Social History of Soviet Trade*; Randall, *The Soviet Dream World of Retail Trade and Consumption in the 1930s*.  
 108 Susan J. Linz (ed.), *The Impact of World War II on the Soviet Union* (Totowa, NJ: Rowman and Allanheld, 1985); Vera S. Dunham, *In Stalin's Time: Middleclass Values in Soviet Fiction* (Durham, NC: Duke University Press, 1990), pp. 3–18; E. IU Zubkova, *Russia after the War: Hopes, Illusions, and Disappointments, 1945–1957* (Armonk, NY: M.E. Sharpe, 1998), pp. 31–56, 101–8.  
 109 Jeffrey W. Jones, *Everyday Life and the 'Reconstruction' of Soviet Russia during and after the Great Patriotic War, 1943–1948* (Bloomington, IN: Slavica Publishers, 2008), pp. 180–212.  
 110 Dunham, *In Stalin's Time*.  
 111 Chauncy D. Harris, 'Urbanization and Population Growth in the Soviet Union, 1959–1970', *Geographical Review* 61.1 (1971), 102–24, doi:10.2307/213369; Harris, *Communism on Tomorrow Street*.  
 112 Iurii Gerchuk argues that the critique of architectural excess by Khrushchev and a number of high-ranking architects brought 'radical aesthetic consequences' that affected decorative art. Iurii Gerchuk, *Krovoizliianiie v MOSKh, ili Khrushchev v Manezhe* (Moscow: Novoe Literaturnoe Obozreniie, 2008), p. 13.  
 113 This urge was both expressed and further stimulated by the series of essays by Vladimir Pomerantsev, entitled 'On Sincerity in Literature', published in the leading literary journal *Novy mir* in December 1953. V. M. Pomerantsev, 'Ob

- iskrennosti v literature', *Novyi mir* 12 (1953), 218–19. For the meanings of truth and sincerity in post-Stalin intellectual milieu and broader public culture, see Zubkova, *Russia after the War*; V. M. Zubok, *Zhivago's Children: The Last Russian Intelligentsia* (Cambridge, MA: Belknap Press of Harvard University Press, 2011). In a non-scholarly but essayistic manner, the issue of the 'search for deep truth' in the 1960s is considered in a book by two writers who reckon themselves among the *shestidiesiatniki* ('people of the 1960s'): Aleksandr Genis and Piotr Vail', *60-e: mir sovetskogo cheloveka* (Ann Arbor, MI: Ardis, 1988).
- 114 Aleksandr Saltykov, 'O khudozhestvennom kachestve promyshlennykh tovarov', *Sovetskaiia Torgovlia* 9 (1954), 22.
- 115 Aleksandr Saltykov, 'Voprosy razvitiia dekorativno-prikladnogo iskusstva', *Iskusstvo* 2 (1955), 30–2.
- 116 Ibid.
- 117 The debates on the nature of composition and construction were held at the Institute of Artistic Culture (Inkhuk) in January–May 1921. While the participants in this debate held diverse opinions, a particularly strong voice came from those who saw composition as an arbitrary combination of elements, depending on an artist's subjective vision, and construction as an essential and clear basis for an artwork, an architectural edifice or a useful object. For example, Aleksandr Rodchenko defined construction as the only possible expression of an artist's concrete aim, while composition had been a symptom of the aimless art of the past; he also compared construction to the organisation of politics and social life in Soviet Russia. ('Protokol no.9 of 1/1–1921 g. Rabochaia gruppa ob"ektivnogo analiza Inkhuka. Analiz poniatii konstrukttsiia i kompozitsiia i moment ikh razgranizheniia', private archive.) At another session, Varvara Stepanova stressed the 'tremendous distinction' between composition and construction: if the former is based on superfluity, the latter is devoid of excessive materials and elements. (Zasedaniie sektsii otdel'nykh iskusstv Inkhuka 25 ianvaria 1931 g. prot. no.22. Analiz poniatii konstrukttsiia i kompozitsiia i moment ikh razgranizheniia (prodolzheniie)', private archive; copies of both documents were provided courtesy of Serguei Oushakine.) The results of this debate were a decisive factor for the development of Constructivism as the movement for integrating art into industrial production and social policy. Like the 1950s discussion of the 'honest object', the composition–construction debate can be interpreted as the search for symbolic order in a situation of social and political turmoil and change. The debate has been analysed in a number of scholarly works. For a concise analysis, see Christina Lodder, *Russian Constructivism* (New Haven, CT: Yale University Press, 1985). For a more detailed discussion, based on newly available archival documents, see Gough, *The Artist as Producer*.
- 118 TsGALI SPb, f. 266, op. 1, d. 291, ll. 72–89.
- 119 Sergei Temerin, 'Izuchenie dekorativnogo iskusstva v sovetskom iskusstvovoznanii za 40 let', *Dekorativnoe Iskusstvo SSSR* 1 (1958), 30–6; Richard Stites, 'Anti-iconoclasm', in Richard Stites, *Revolutionary Dreams: Utopian Vision and Experimental Life in the Russian Revolution* (Oxford: Oxford University Press, 1989), pp. 76–8; Gusarova, 'Leningradskaia keramika', pp. 49–51. Though certain craft cooperatives received the support of art historians and were able to raise the artistic quality of their production (the most prominent example is Aleksandr Saltykov's work for pottery cooperatives in Gzhel'), many others were still poorly equipped and managed in the late 1960s, to a great extent because they had to subsume to general management and planning guidelines and wage norms set by the Central Council for Industrial Cooperatives. Russian State Archive of Modern History, Moscow (hereafter RGANI), f. 5 op. 36 d. 48, ll. 103–6.
- 120 TsGALI SPb, f. 266, op. 1, d. 291, l. 81.
- 121 Saltykov, 'Voprosy razvitiia dekorativno-prikladnogo iskusstva', 32.

- 122 Aleksandr Saltykov, 'Prikladnoe iskusstvo trekh respublik (o vystavke proizvedenii khudozhnikov Latvii, Litvy i Estonii)', *Iskusstvo* 6 (1955), 12.
- 123 Nikita Voronov, 'Narodnye traditsii I sovremennoe iskusstvo', *Dekorativnoe Iskusstvo SSSR* 1 (1958), 9. [AQ 1957 in text]
- 124 Ibid.
- 125 An expression used by Aleksei Balashov, head of the LSSKh section of decorative-applied art, at a meeting devoted to the discussion of Estonian applied art, 16 April 1954. TsGALI SPb, f. 78, op. 4, d. 287, l. 63.
- 126 TsGALI SPb, f. 266 op. 1, d. 291, l. 82.
- 127 TsGALI SPb, f. 78, op. 4, d. 287, l. 56.
- 128 TsGALI SPb, f. 266, op. 1, d. 291, l. 88.
- 129 TsGALI SPb, f. 266, op. 1, d. 291.
- 130 TsGALI SPb, f. 78, op. 4, d. 517, l. 6.
- 131 TsGALI SPb, f. 78, op. 4, d. 46, l. 11.
- 132 TsGALI SPb, f. 78, op. 4, d. 46, ll. 85–6.
- 133 Susannah Handley, *Nylon: The Story of a Fashion Revolution. A Celebration of Design from Art Silk to Nylon and Thinking Fibres* (Baltimore, MD: Johns Hopkins University Press, 2000).
- 134 'Flying Colours', *Design* 152 (1961), 66–7.
- 135 Eli Rubin, *Synthetic Socialism: Plastics and Dictatorship in the German Democratic Republic* (Chapel Hill, NC: University of North Carolina Press, 2009).
- 136 Nina Dmitrieva, *O prekrasnom* (Moscow: Iskusstvo, 1960).
- 137 Degot', 'Ot tovara k tovarishchu', 37.
- 138 Dmitrieva, *O prekrasnom*, p. 69.
- 139 Amateur craft-making circles (*kruzhki samodeiatel'nosti*) were encouraged in Soviet Russia, at least in big urban centres, after the restructuring of artistic organisations in 1932. In this year the sector of amateur art was opened in the newly founded Moscow Regional Union of Soviet Artists (MOSSKh) (RGALI, f. 2943, op. 1, l. 32). In 1953 the USSR Ministry of Culture allocated 90,000 roubles for maintaining amateur circles in the Russian Soviet Republic (RGAE, f. 7733 op. 42 d. 1152, l. 30). In Leningrad, by 1954 every House of Culture included a studio of knitting, open to visitors (TsGALI SPb, f. 78, op. 4, d. 287, l. 39). The popularity of these circles impelled professional artists to take control of their activity, which was perceived as potentially damaging to mass taste, since the circles' instructors often lacked special artistic education. This problem was often discussed in gender terms, since 'housewives' were reported to constitute the majority of the circles' attendees. RGALI, f. 2943, op. 1, d. 2477, l. 52.
- 140 'Iskusstvo v byt', *Dekorativnoe Iskusstvo SSSR* 6 (1961), 5.
- 141 This same kitchenware was considered out-of-date by the employees of Leningrad VNIITE and was to be replaced by rational models, designed in 1965–66, as discussed in [Chapter 3](#).
- 142 O. Baiar, 'Krasivoe v prostom', *Dekorativnoe Iskusstvo SSSR* 7 (1961), 1–6.
- 143 TsGALI SPb, f. 78, op. 5, d. 413, l. 10.
- 144 'Iskusstvo v byt'.
- 145 Sergei Gurov, 'Dlia vashego doma' (Central Red Banner Studio of Documentary Films, 1962), Russian State Archive of Cine-Photo Documents, Moscow (hereafter RGAKFD), d. 18199.
- 146 Reid, 'Khrushchev Modern', 227–68.
- 147 Régis Debray, 'Socialism: A Life-Cycle', *New Left Review* 2.46 (2007), 5–28.

## 2

### Technical aesthetics against the disorder of things

In March 1964 *Dekorativnoe Iskusstvo SSSR* published an overview of modern modular furniture. It opened with a description of modern objects' rapid intervention in the home:

The TV set required rearrangement. Turning its back to the light, it oriented the recreation zone around itself. This attracted soft chairs, a collapsible sofa, a coffee table and decorative objects, whereas a dining table, which used to occupy an honourable central place in the room, had to move closer to the wall. Doing so, it did not manage to preserve its round shape and became rectangular.

Despite the centrality of the television, the article's author, A. Piletskii, seemed not to consider it to be an all-important modernising force within the home. Rather, any changes in the home had to be carefully guided by a designer or by a properly informed inhabitant. The rational rearrangement of habitually used objects was only a transitory stage in the development of the home. A modern interior should take the form of a grid on which all objects are placed:

Contemporary cabinet furniture is a well-ordered structure of sectional cases that fills a wall. Regardless of its type (sectional, collapsible or shelves), it has a definite module and rhythm [...] Ceramics, glass, light fixtures, books, prints, souvenirs, plants, fabrics and other household objects infuse this structure, fill it, introduce vibrancy to it; everything ties in a coherent whole.<sup>1</sup>

Hence, while encouraging vibrancy and a certain diversity in the modern Soviet home, Piletskii specified that such diversity should be constrained, subjected to a spatial grid. However, he did not mean that all the objects in a room should be uniform in appearance. In the 'period of the predominance of excess in architecture and furniture' (late 1940s–early 1950s), both furniture and brown goods were bulky and ponderous,

often featuring polished surfaces, and each object demonstrated individual dimensions and finishing. These designs were distasteful, Piletskii argued. With the arrival of modernist aesthetics to the Soviet home in the 1960s, furniture became lighter in terms of weight and colour, and singular objects gave way to complexes of modular furniture – ‘a well-ordered structure of sectional cases that fills a wall’. Attempts to subordinate brown goods to modular principles were forlorn, because they remained ‘alien’ to furniture even when mimicking its external shapes and visual style. As a better alternative, Piletskii proposed the principle of contrast: brown goods should visibly differ from furniture units in terms of shape, material, finishing and colour, manifesting their more unique, interactive character. Yet a grid of traditional household objects and a set of expressive, modern electronic devices should always be balanced. After all, ‘what is most essential is integrity, interconnectedness and compositional unity. It is not even that important if these are achieved by contrast or by similarity.’<sup>2</sup>

This text illustrates remarkably Soviet design professionals’ recognition of the active role of objects in the home. Hitherto unknown objects that differed in their formal and functional qualities, in particular the ‘new-comers’ such as the TV set or vacuum cleaner, forced the inhabitants to think differently about their home and their everyday life. The promise of the Party and government to ‘fully satisfy the constantly growing material and cultural demands of the Soviet people’<sup>3</sup> by increasing the quality and quantity of available consumer goods implied the high social and cultural potential of objects. Historians emphasise the government’s promise of the proliferation of goods and better homes as one of the key characteristics of the post-Stalin period.<sup>4</sup> Denis Kozlov and Eleonory Gilburd argue that, in terms of the heightened attention to the living conditions of the now predominantly urban society, the USSR in the 1950s and 1960s was comparable to European countries whose material environment had been severely damaged by the Second World War.<sup>5</sup> As Kozlov and Gilburd note, ‘Unprecedented in the household context, Khrushchev’s mass housing campaign belonged with contemporary trends in urban planning, construction technology, welfare and aesthetic vision’. They label the government’s effort to reinforce its legitimacy by increasing people’s material prosperity and paying greater attention to consumer goods as the ‘Soviet regime’s new materialism’.<sup>6</sup> This is, evidently, an ironic allusion to new materialism as a currently popular school of thought that is based on reconsidering the epistemological and ontological premises of conventional social science research.

The full irony of Kozlov and Gilburd’s wording is in the strong contrast between the post-war Soviet modernist vision of material culture as manageable through and through, and the new materialist recognition of the agency of inanimate matter. According to Elizabeth A. St Pierre et al., there are many new materialisms practised by scholars in different disci-

plines, but they are all united by a critique of the foundational assumptions of Western thought, in particular the division between a knowing subject and an inert object, between an exceptional human being and passive matter ‘waiting to be acted upon’.<sup>7</sup> Additionally, St Pierre et al. explain that new materialisms are driven by curiosity and therefore have no definitive methodology – they are ‘always being laid out, becoming’.<sup>8</sup> This methodological fluidity is related to the reconsideration of the doer/deed relationship: ‘If we take seriously that there is no “doer behind the deed” but that the doer is produced either by or alongside the deed, then the work of method is not completely in our control and must be constantly re-thought and re-claimed in each specificity.’<sup>9</sup>

Contrary to this, the ‘new materialism’ of the Khrushchev government was a policy that favoured belief in the exceptional human being, an expert in urban planning, design and aesthetics, who is capable of organising inert matter into proper socialist objects and furthering rational consumption and daily life. Khrushchev’s modernisation campaign left little room for what new materialists call *thing-power* – ‘the strange ability of ordinary, man-made items to exceed their status as objects and to manifest traces of aliveness, constituting the outside of our own experience’, in Jane Bennett’s definition.<sup>10</sup> The structure of VNIITE directly manifested the state’s will to control, through a network of experts, the totality of things and their influence on consumers. The ‘TE’ in the institution’s acronym, ‘technical aesthetics’, was promoted as an interdisciplinary science that defined the ‘laws of artistic activity in the sphere of technology’<sup>11</sup> and optimised the production of consumer goods. VNIITE employees, therefore, shared the scientific establishment’s interest in cybernetics.<sup>12</sup> In the Soviet context, this entailed ‘the science of managing national planning and economy, administering perfectly calculated goods and services, collecting and interpreting data, and establishing and meeting production quotas’.<sup>13</sup> Design historian Margareta Tillberg suggests that Premier Aleksei Kosygin appreciated mathematical modelling and computer networks – important components of cybernetics – as tools for increasing the efficiency of the socialist production system without giving way to the evils of the capitalist market. The model of ‘industrial cybernetics’, developed in the 1950s by Stafford Beer for the steel industry in England, was well known in the USSR through the Russian translation of his 1959 book *Cybernetics and Management*. Beer’s model replaced standard market mechanisms of supply and demand with feedback loops that provided data about aspects such as sales rates, available materials and costs in managing complex companies. Within this model, the Soviet economy appeared ‘as an enormous organism that could be optimized by way of computer networks through the channelling and management of information flows’.<sup>14</sup> This optimisation would further the ordering of material culture. As Diana West argues in her study of Soviet cybernetics, by appropriating this Western

interdisciplinary science, ‘Soviet designers at VNIITE aimed to account for all human physiological and psychological needs in designing a comprehensive system of consumer objects’.<sup>15</sup>

This chapter addresses the contradictions of the ‘new Soviet materialism’ by focusing on the work of VNIITE during the initial stage of its establishment. In that period, the institution focused on overcoming what could be called, alluding to Foucault’s seminal work, the disorder of things.<sup>16</sup> Several theorists, referring to Kant’s notion of the ‘thing-in-itself’ and its later interpretation by Heidegger,<sup>17</sup> distinguish between objects as accessible, instrumental entities, and things as agents of social relations, acting outside human control. Bill Brown asserts that people have ready codes to grasp the meaning of objects and use them without confronting their materiality: for example, we look through windows. However, once objects stop working for us – for example if a window gets dirty – we start confronting their ‘thingness’, which is not immediately intelligible.<sup>18</sup> Similarly, Jane Bennett argues that unusable objects, such as those in a rubbish pile, appear as things: ‘as vivid entities not entirely reducible to the contexts in which (human) subjects set them, never entirely exhausted by their semiotics’.<sup>19</sup> Following this conceptual distinction, I suggest that the main goal of VNIITE in the 1960s was to replace the unruly and malfunctioning things that filled Soviet homes or piled up unsold in warehouses with neat, functional objects. The chapter begins with an overview of the genealogy of the key terms that defined VNIITE’s activity. Further, it discusses VNIITE’s methodologies for studying consumer needs, evaluating already produced objects, and designing new ones. Finally, it presents case studies exploring how these methodologies were implemented in the design of household objects.

### Coming to terms with design

As I demonstrated in the first chapter, the aesthetic turn included a great deal of conceptual and terminological confusion. The idea of a late socialist object and industrial design as a Soviet profession emerged partly because of art theorists’ attempts to overcome this confusion. In order to optimise the production of objects, design professionals required a solid, effective terminology. As early as 1955 the critic Moisei Kagan was frustrated that specialists working on furniture, clothes, kitchenware, etc., randomly referred to their own work as ‘decorative’, ‘applied’, or ‘decorative-applied’ art. He insisted that ‘decorative art’ was the term for decorative elements that have no practical use in themselves (such as decorative vases or wall-papers), while ‘applied art’ signified practically usable objects.<sup>20</sup>

The need for a clear differentiation gained urgency by the 1960s. Ivan Matsa (Macza János), an art critic of Hungarian origin with experience of the 1920s Hungarian avant-garde, published an article in *Dekoratívnoe*

*Iskusstvo SSSR* with the polemical title ‘Can the Machine be a Work of Art?’<sup>21</sup> Answering this question in the negative, Matsa specified that means of production (machines) can possess beauty but only as a consequence of their technical perfection, not as an intentionally produced quality. Moreover, even though artists sometimes partake in the production process through artistic labour, what they produce are not proper works of art. Household objects, however, including new ones, are made intentionally beautiful and act as ‘ideological facts’ by expressing certain social values. They, as such, belong to the sphere of art, or, at least, in the category of ‘aesthetically meaningful objects’. Matsa’s hypothesis implied that refrigerators and cars produced at the same Likhachev plant, for example, were situated on different sides of the divide, whereas refrigerators and porcelain tableware were united by ideological meaningfulness, although the former did not belong to decorative art proper.

Matsa’s attempt to draw further distinctions between different kinds of art-like objects was shaky, the argumentation cautious and the overall classification vague. Nonetheless, Matsa called for further work in this direction, seeing these distinctions as crucial for avoiding the ‘mistakes’ of the 1920s avant-garde:

If one transforms, say, a chair into an object of decorative art, a fabric into a propaganda leaflet, an ashtray into a hybrid of a sculpture and a poster, and interprets a carpet as an easel painting, this, in fact, strongly resembles the unfortunate attempts of those who tried to turn an easel painting into a construction and poetry into the ‘literature of facts’ [...] Neglecting the specificity of the artistic production of useful objects can not only lead to aesthetic nonsense and tastelessness, but also causes everyday troubles, physical discomfort and the waste of valuable materials.<sup>22</sup>

With the implicit reference to the ideas of Constructivism and the *LEF* group (particularly the 1925 volume *Literature of Facts* that included Sergei Tretiakov’s article ‘Biography of an Object’),<sup>23</sup> this passage signals not only Matsa’s attempt to downplay his avant-gardist past, but also the dialectics of modernism. Matsa accused the constructivists of dangerously mixing things of a different nature at the very same time as the Soviet Ministry of Culture and the official art institutions were preparing a large exhibition in Moscow entitled with the constructivist slogan ‘Art into Life’. The avant-gardist urge to fuse art with life that suited the state’s campaign to improve the quality of consumer goods and daily life was also accompanied by the effort of professionals to differentiate art from non-art. In fact, productivist theorists such as Tarabukin and Arvatov drew a line between traditional applied art and the ‘production art’ of the new proletarian society.<sup>24</sup>

Matsa’s article proved to be groundbreaking for the aesthetic turn. A month later it received a response from the painter of battle scenes Anatolii Gorpenko, who believed that Matsa had instigated an important discussion



that facilitated the clarification of ‘the basic principles of so-called industrial aesthetics’.<sup>25</sup> He warned against the limitless expansion of the notion of art and the ‘dissolution of art in production’, characteristic of the theorists of Constructivism. This dangerous confusion had already been realised, Gorpenko noted, in the ‘intentional technisation’ of household objects, which often looked like equipment from a technical laboratory. Thus, he did not rush to follow Matsa in calling everyday objects art or at least art-ish. Besides technics and applied art (understood as traditional household objects endowed with emotional and poetic meaning), Gorpenko distinguished ‘a broad sphere of non-artistic production, where an aesthetic factor plays a decisive role’. In this latter category he included such objects as cars, refrigerators, household appliances, radio receivers, standard furniture and even fountain pens. The main criterion for dividing this sphere from applied art was the direction of aesthetic evaluation. In the case of utilitarian everyday objects (*predmety shirokogo potrebleniia*, literally ‘the objects of broad consumption’, a standard Soviet expression), we evaluate the object itself rather than its symbolic meaning. Thus, for example, a pair of shoes can be light and refined; the form of a car can be elegant, smooth and dynamic. For applied art (which he occasionally calls ‘decorative’), Gorpenko’s aesthetic evaluation is directed not so much at the object, as to what this object signifies. Works of applied art ‘can be festive or lyrical, emotionally intense, can express different tones and hues of aesthetic feeling, provoke us to imagine the morning freshness of nature, the vivid colours of a sunny day, the spring bloom or the cold magnificence of a winter landscape’.<sup>26</sup>

This approach recalls Nina Iaglova’s vision of applied art as essentially representational, *izobrazitel’noe*. Unlike utilitarian everyday objects, which all share the same expressive meanings based on their type (e.g. cars express forwardness), each work of applied art reflects the individuality of its creator and his or her ‘spiritual constitution’ and life-perception. Most importantly, for Gorpenko, the utilitarian function in works of applied art changes by acquiring ‘decorative meaning’ due to their strong ‘semantic and emotional charge’. Utilitarian objects, on the other hand, often have a complicated and self-sufficient technical organisation that does not leave room for emotional expressiveness. This line of argument led Gorpenko to a compromise between an anti-excess modernist stance and a socialist realist insistence on depiction: images and ornaments are welcome in works of applied art, but for utilitarian objects they are inappropriate and excessive. This conclusion, moreover, reveals the different role of materiality in Gorpenko’s two spheres. In applied art, symbolic and emotional meanings predominate, whereas the aesthetic value of utilitarian objects resides in their sensory qualities: the ‘beauty of the material’, the ‘elegant and expedient construction’. Finally, at the very end of his essay, Gorpenko claimed that there was no universal working method that could be equally relevant for both spheres.<sup>27</sup>

Twelve more opinions followed: the initial discussion about art, machines and aesthetics lasted for almost three years in *Dekorativnoe Iskusstvo SSSR*. The need for the clear conceptualisation of artistic work in industry proved to be a key question of the post-Stalin aesthetic regime of arts. The philosopher (and future human rights activist) Boris Shragin immediately responded to the Matsa–Gorpenko debate, arguing that aesthetic theory in general tends to fall behind the development of technology and material culture and could not keep up with the rapid changes of recent decades. The result, he argued, was a paradoxical situation: his colleagues could admire machines and practical household objects as human beings, but they vigorously denied this admiration as professionals. In order to catch up with the development of technology, aesthetic theory needed self-criticism and to recognise that its principles should be fluid, socially conditioned and historically changing. Shragin presented the ancient Greek term *techne*, which referred to all types of creative activity, as useful for describing the material culture of post-industrial societies.<sup>28</sup>

Karl Kantor, a major theoretical contributor to *Dekorativnoe Iskusstvo SSSR*, objected to Gorpenko's classification, describing materiality as an artistic force that differed from decoration:

simple geometric forms of furniture, the clear rhythm of straight outlines, completeness and coherence between the elements of the form of each object and between different objects (achieved not only by strict calculation, but also by the artist's inspiration and intuition), the clarity of smooth surfaces of ash, covered by transparent polish that does not hide the beautiful texture of the wood, the solidity of planks – all this creates an indelible artistic impression. This simple, unostentatious furniture embodies reliability, restrained dignity, repose and light clarity, which is not the same as the clarity of rational thinking (because it possesses the warmth of vibrant human feeling), but neither is it alien to such thinking. It is good to live with such furniture. It will not oppress, overwhelm, and prevail over a person.<sup>29</sup>

While this passage recalls Aleksandr Chekalov's conceptualisation of vibrancy from 1957 (discussed in [Chapter 1](#)), Kantor's argumentation had a practical implication: artists are not only those who work on representational handicraft objects; artists are urgently needed in different branches of industry, from furniture to mechanical engineering. Kantor's belief was that art, understood as the masterful processing of material to shape it into expedient and functional forms through a fine balance of rational thinking and intuition, should be the precondition for comradely, non-oppressive objects. His contribution to the debate implied that applied art has no clear borders.

Similarly, art historian Iurii Gerchuk recognised the aesthetic component in machines and household objects, but expressed uncertainty regarding the relevance of the label 'applied art': notably, he titled his

article 'The Machine as a Work of *Industrial Art*' (my emphasis).<sup>30</sup> He criticised both Matsa and Gorpenko for drawing borders between art and technics, as he believed that contemporary technological development outran any such borders. Instead of a cosy world of habitual household objects, opposed to a 'cold and somewhat scary' world of technics, there emerged a diversity of objects with different types of beauty and degrees of technological advancement that constitute our everyday experience. He concluded that the recognition of technological progress as an aesthetic phenomenon affected the sphere traditionally viewed as applied art and transformed the appearance of household objects. 'Contemporary applied art' could not exist in the forms produced by handicraft. Thus, the division he suggested was not typological, but chronological: applied art as hand-made and ornamental belonged to the past, while applied art informed and reinforced by technological progress was urgently needed by modern Soviet people.

The roundtable, concluding the discussion initiated by Matsa, gathered at the *Dekorativnoe Iskusstvo SSSR* editorial office at the end of 1963, approximately a year and a half after the establishment of VNIITE.<sup>31</sup> Evgenii Rozenblium, art director of the 'special artistic-engineering bureau' of the Moscow Economic Council (*sovmarkhoz*), one of the first regional design institutions in the USSR, enriched the discussion by outlining the nascent theory of design in a socialist society. His colleagues at the bureau had been educated as sculptors, applied artists and architects, and now worked on a broad range of projects, from machines to theatre props. They followed the discussion with great attention, trying to figure out if what they did was art or not quite art: 'A year ago, we were all still creating artworks. And what now? Have we stopped producing them?'<sup>32</sup> From there, Rozenblium proceeded to raise the problem of the relationship between humans and machines and the problem of style as 'one of the means of technical progress'.<sup>33</sup> In essence, he delineated the problems that were currently central to the agenda of VNIITE. Additionally, Rozenblium noticed, Matsa's discussion had fulfilled its instigating purpose and had now exhausted its potential. The very notion of applied art had lost its decisive theoretical role.

Since its establishment, VNIITE had avoided the notion of applied art altogether. Drawing on his familiarity with the British experience of institutionalising industrial design, Soloviev and his colleagues faced the task of adapting this concept to the Soviet reality. The Anglophone term 'design' was ideologically unacceptable: Soviet authorities in the early 1960s would not sanction an institution that promoted a 'bourgeois' concept.<sup>34</sup> However, I suggest that the refusal of the term 'design' was additionally motivated by VNIITE's orientation towards creating clear systems: to combat the disorder of things, a designer first had to eliminate the disorder of terms, which the adoption of the Anglophone word would only exac-

erbate. A new system of precise terms would also ensure continuity with the earlier discussion among productivists on defining industry-oriented art, thus emphasising the specific character of Soviet design.

This continuity was explicitly stated by the prominent art historian Larisa Zhadova in her talk at the Convention on Artistic Engineering that was organised by VNIITE in Tbilisi in May 1964 and gathered designers from all over the Soviet Union (except for Central Asia where design organisations were not yet established), as well as from Poland, Czechoslovakia, Hungary, East Germany and Bulgaria.<sup>35</sup> This was, in fact, the first international event for socialist design. Calling for a universal design terminology throughout the socialist bloc, Zhadova searched for its roots in early Soviet Russia. She recalled the imperfect terms of the late 1910s to the 1920s, 'technical art' (*tekhnicheskoe iskusstvo*) and 'industrial art' (*industrial'noe iskusstvo*), the former meaning the artistic impact of technical tools and the latter adjusting applied art to industrial technology. A better term, from the early 1920s, 'production art' (*proizvodstvennoe iskusstvo*), accentuated the 'principal novelty of the nascent phenomenon' and the 'radical shift of aesthetics towards material practice and production'. However, Zhadova argued that in the current situation this term sounded 'naïve, limited and unclear', as 'production' could refer equally to handicraft, workshop and modern industry. It was considered no more relevant in 1964 than the Anglophone 'industrial design', which was criticised as too broad and vague.

For a model of clear and comprehensible design terminology, Zhadova turned to the European countries of the socialist bloc. They were not only the mediators of Western design, but also had their own knowledge on design to share. Czechoslovakia, an industrially developed country with a rich tradition of glassmaking, had attracted Soviet designers since the early 1950s. This interest intensified by the end of the decade, when Czechoslovakia became a popular destination for artists' research trips.<sup>36</sup> In 1960 Moscow hosted the exhibition 'Czechoslovakia 60', which included work instruments designed by Petr Tucny, the originator of the term 'technical aesthetics' (*technická estetika*).<sup>37</sup> In November 1960 the USSR Ministry of Higher and Vocational Education sent a group of artists, architects and engineers of different profiles, as well as economists and linguists, to learn from Czechoslovak industry, design, art and pedagogy for a year.<sup>38</sup> Aleksandr Korotkevich, the head of the Department of Industrial Art at MVKhPU, participated and was impressed by Czechoslovak designers' engagement in the mass housing campaign and industrial production of goods. He specifically noted 'the science of industrial aesthetics' promoted by Zdenek Kovar, professor of the Prague Institute for Arts and Crafts. Simultaneously, Tucny accepted an invitation to take a short-term job in Moscow. In cooperation with the construction bureau of the famous aerospace engineer Andrei Tupolev, he designed a number of machine

tools for the aviation industry.<sup>39</sup> This is how Tucny's 'technical aesthetics' was planted in Soviet soil, although in a distorted form. While Tucny used 'technical aesthetics' as a theory for improving the conditions of industrial labour through ergonomic machine tools, Soviet designers interpreted this term in relation to the design of both capital goods and consumer goods.<sup>40</sup>

The Czechoslovak import of still unstable terms, coupled with diverse interpretations of them in the Soviet design community, created a logical confusion, further intensified by the chaos of definitions for artists working in industry in cooperation with other specialists. The situation resembled the earlier search for proper terminology among industry-oriented artists in the late 1920s, when such terms as 'artist-constructor', 'constructivist', 'artist-technologist', 'engineer-artist' or even the cumbersome 'engineer-artist-constructivist' were used at different moments and in different settings.<sup>41</sup> Although Zhadova admitted at the 1964 Tbilisi convention that a 100 per cent stable terminology was impossible, she offered a conventional scheme, systematising the terms that had already been in circulation for a while: 'the new sphere of artistic creativity is industrial art [*promyshlennoe iskusstvo*]; the method of practical fulfilment of the task of industrial art – artistic engineering [*khudozhestvennoe konstruirovaniye*];<sup>42</sup> the theory of industrial art – technical aesthetics [*tekhnicheskaya estetika*], and the new type of artist, different from applied artists and decorators – artist-constructor [*khudozhnik-konstruktor*]'.<sup>43</sup> This terminology was officially accepted, even though the implications of each term continued to be debated, specified and expanded on at professional meetings and in *Dekorativnoye Iskusstvo SSSR* throughout the 1960s and after, until the Anglophone terms *dizain* and *dizainer* were officially accepted in the mid-1980s. Thus, coming to terms with the avant-garde legacy alongside the Western model and with the experiences of their East European socialist colleagues, Soviet designers outlined a contemporary way of speaking about their profession and a terminological toolkit to solve concrete tasks more effectively.

### Managing the chaos of forms

Armed with a clear system of terms, VNIITE specialists confronted the disorder of things that plagued Soviet industry and trade. As they stated in a 1965 report on current production, the variety of Soviet goods 'is not based on the advantages of the socialist economic system and, instead of producing a limited, optimal assortment of high-quality goods, we produce many defective objects that duplicate each other'. This approach, the VNIITE designers believed, was characteristic of capitalist countries and therefore alien to the USSR, and it could bring 'serious economic, ideological and political costs'.<sup>44</sup>

Indeed, socially oriented Western designers of the post-war period criticised the chaotic flow of mass-produced goods. Their search for comprehensive and responsible standards became central to the work of organisations such as the British CoID and was an important objective of the ‘good design’ movement.<sup>45</sup> The disorder in the material environment in industrialised societies was on the agenda of the 1963 ICSID congress in Paris<sup>46</sup> – Rozenblium called it a ‘chaos of forms’.<sup>47</sup> Notably, according to the design historian David Raizman, this disorder was perceived in connection not only to the market but also to totalitarian ideologies: ‘Shared standards and limits to the expressions of individual will, whether in product design, graphic design, or political or moral attitudes, were viewed as bulwarks against manipulations by advertisers or demagogues, especially in an age of mass communication and amid lingering fears of totalitarianism.’<sup>48</sup> It is possible to argue that VNIITE professionals, too, devised technical aesthetics as a stronghold against the arbitrary tastes of political leaders as well as managers in industry and trade, keeping in mind the exuberance of Stalinist architecture and interior design. Being a part of the aesthetic turn, technical aesthetics considered the needs of ordinary people instead of glorifying the state and Party leaders. As Soloviev explained, this young scientific discipline ‘represented consumers’ interests in production’.<sup>49</sup> In this respect, VNIITE followed the lead of post-war Western advocates of modern design in striving to serve public interests.<sup>50</sup>

For VNIITE designers, however, the main obstacle was not the deliberate manipulation of consumer interests for political purposes, but a rigid planned economy focused on quantity rather than quality. As designers unceasingly emphasised, newly built flats not only often had poor layouts, they were difficult to properly furnish and make comfortable.<sup>51</sup> The enterprises that produced household objects were blamed not so much for insufficient production as for the lack of coordination and the resulting excess and chaos of products. Generally, goods of the same type (such as refrigerators) were produced by several factories that were answerable to different ministries. These models closely resembled each other and were often, as designers painfully noted, obsolete. As such, demand for them lessened over time and unused, obsolete products filled Soviet warehouses. A related problem was that available household goods of different types and categories were often stylistically discordant. Therefore, people could not get proper furnishings for their homes not because of insufficient production, but because of an excessive variety. In the very first issue of *Tekhnicheskaja Estetika*, the economist Iakov Orlov presented this problem as evidence of ‘the lack of integral technical and aesthetic policy’.<sup>52</sup>

Claiming that the chaos of forms vitiated the advantages of a socialist economy, which was meant to produce a powerful alternative to capitalist consumer culture, Soviet designers also admitted that Soviet goods were significantly poorer than Western ones. VNIITE reports explicitly stated

that Soviet consumer objects were pale analogues of Western goods. In one 1965 report, the ergonomic factor was cited as playing an essential role. For example, the electric shaver *Utro*, designed entirely by engineers and produced by one factory under the oversight of the Leningrad Economic Council, had a handle with a small diameter, similar to a screwdriver or an awl. The use of such tools presupposes a direction of force along their axis, whereas shaving requires the sliding of the shaver's head over the skin, for which a tool-like handle is unsuitable because the holding hand is in a horizontal position. VNIITE designers characterised this shape with the colloquial term *neprikladista* – literally 'non-applicable'. The best translation may actually be 'not user-friendly', though it does not indicate the sense of touch as much as the Russian original does. In contrast, the *Milward Courier*, a British shaver designed in 1961 by Kenneth Grange for Henry Milward & Sons, was praised as well shaped to the specific hand movements of the shaving process, or *prikladista* – user-friendly.

The British shaver also seemed superior because of its ease of maintenance: it came with a knife for cleaning the cutter screen, while the Soviet shaver's design made cleaning more complicated. The *Milward Courier* also had a power button located under the index finger that prevented the user from accidentally turning the shaver off, as could easily happen with the *Utro*. Even the case of the British model impressed Soviet designers, as it was light, elegant and precise in holding the shaver, while the Soviet one looked more like a camera case and was unrelated to the actual shape of the shaver. VNIITE's analysis concluded that the *Utro* was disappointing, while the *Milward Courier* demonstrated 'high aesthetic qualities', harmoniously combined with 'convenience of use, logical and simple construction and, simultaneously, technological excellence': in short, it 'united the qualities that constitute the basis and principles of artistic engineering'.<sup>53</sup> Thus, while insisting that the socialist economic system was the only precondition for proper 'artistic engineering', VNIITE found its ideals in 'capitalist' objects. This was a necessary compromise. A similar conclusion resulted from the comparison between Western and Soviet vacuum cleaners, hot plates and other household objects.<sup>54</sup>

This was not a naïve lament over the disappointing, deficient objects still sold in a country that anticipated the arrival of full-blown communism in less than twenty years. The VNIITE report, like several articles in *Tekhnicheskaiia Estetika*, offered a precise list of causes for the disorder of things: a lack of scientifically justified variety in consumer goods; the poor development of consumer opinion research; a disregard for technical aesthetics by the State Committee for Standards; a lack of design services at the majority of enterprises producing consumer goods; a lack of coordination between the trade shows and the work of economic councils on approving new prototypes for consumer goods. The report went on to give a list of recommendations that included an urgent call to create optimal



All rights reserved and permission to use the figure must be obtained from the copyright holder.

**2.1** Comparative analysis of British electric shaver the Milward Courier (left) and Soviet analogue Utro (right), 1965.



varieties for different types of consumer goods; the development of norms and standards for consumer products informed by technical aesthetics; the abandonment of all existing systems for the approval of new prototypes in favour of a new, quality-oriented system; and placing greater responsibility on the heads of enterprises who gave final approval. The report also advocated direct agreements between industries and trade organisations and the establishment of a permanent exhibition of approved prototypes that would showcase them in clear arrangement according to their types: thus, shavers, for instance, produced by different factories, could be easily compared when juxtaposed with one another. This universal exhibition would be subject to regular inspections by an expert committee that would remove exhibits found to be irrelevant to consumer needs. The show would be open to the public and be used to research public opinion.<sup>55</sup>

From 1965 Brezhnev–Kosygin’s recentralisation of Soviet planning meant that the task of policy integration and production control became even more acute. In a 1966 article, the architect Aleksandr Riabushin, employed in the VNIITE department for the design of household goods, called for rigorous scientific methodologies for the regulation (*uporiadochenie*) of production, without which any discussion of stylistic unity would be impossible. Anticipating the objection that standardisation contradicts consumers’ interest in limitless diversity, Riabushin drew a distinction between the terms *nomenklatura* (typology) and *assortiment* (varieties), the former understood as the typology of goods and the latter as the total sum of produced goods. Ideal types of the *nomenklatura* would therefore constitute a harmonious order that would then be embodied by sensible and tangible models of the *assortiment*. While *nomenklatura*, Riabushin believed, would help rationalise production and modernise mass housing, *assortiment* would encompass the variety of consumer tastes.<sup>56</sup> The next logical step would be the total regulation of the material environment, which was indeed the major objective of VNIITE in the second half of the 1960s. Major proponents of this totalistic vision of design were Riabushin and the philosopher Karl Kantor, as well as the philosophers of the Moscow Methodological Circle, headed by Georgii Shchedrovitskii, who joined VNIITE in 1965. The Circle’s critical approach to systems theory in its Western variants and methodological understanding of all kinds of activity resonated with technical aesthetics’ aspiration for the status of a universal science of design.<sup>57</sup> This ambitious task required a system of clear algorithms: for studying consumer demand, evaluating currently produced goods, and for designing new objects that would comprise perfect order.

What ‘people’s needs’ exactly should designers satisfy?

A crucial measure for combating the chaos of forms was to strongly connect production plans to consumer needs. In the late 1950s and early

1960s, informal research on consumer demand was carried out through shoppers' conferences, complaint books that were mandatory for all shops, and letters to popular magazines.<sup>58</sup> In 1960 the Institute of Public Opinion emerged at *Komsomol'skaia Pravda*, the official newspaper of the all-Union Soviet youth organisation (Komsomol). This was not a government initiative, but a grassroots one by the newspaper's editorial board, which consisted of philosophers and journalists.<sup>59</sup> The Institute's second opinion poll in 1960 concerned the 'dynamics and problems of standards of living in the country' and was logically bound to the topic of consumption. According to the Institute's founder, the philosopher Boris Grushin, the four earliest polls lacked a clear scientific methodology, were not at all representative for various social groups throughout the country, and had to comply with the newspaper's ideological guidelines.<sup>60</sup> However, the Institute achieved a higher polling standard from 1961: it developed more representative samples, better systems for coding, and provided better preparation of interviewees and coders. As a result, the Institute's findings entered scholarly sociological publications beginning in 1962. Around the same time, the newly established VNIITE involved *Komsomol'skaia Pravda's* Institute in preparing a questionnaire on domestic radio and TV equipment. This was a part of the designers' project to study consumer demand for 12 groups of consumer goods considered the most socially and economically significant. Relying on methods developed by American sociologists such as William J. Goode in the 1950s,<sup>61</sup> the researchers from the two institutes structured the questionnaire around various consumer groups. Each group was defined by the following characteristics: living conditions, income, family size, type of settlement, occupation, 'cultural level' (education and aesthetic sensitivity), age and national traditions (gender was conspicuously absent from their study).<sup>62</sup> The results of the questionnaire revealed significant dissatisfaction with currently available goods in terms of appearance, performance, size and ease of use. According to a senior VNIITE researcher, these findings would help designers improve the typology of radio devices and provide trade organisations with recommendations for a more rational distribution of commodities throughout the country in accordance with actual consumer preferences. While the report on the initial stage emphasised the danger of 'blindly following' consumer demand and the necessity of educating consumers about taste, it nonetheless described the designers' awareness of consumer demand as a crucial aim of technical aesthetics.<sup>63</sup>

The joint research by VNIITE and *Komsomol'skaia Pravda's* Institute was a response to government discussions on the necessary measures for the systematic study of consumer preferences. A proper research institute for precisely this purpose was organised in June 1965 under the auspices of the USSR Ministry of Trade (abbreviated as VNIKS).<sup>64</sup> Its tasks included studying consumer needs, developing precise methods for

monitoring and predicting them, and presenting the research outcomes to trade and industry. Regional branches of VNIKS appeared in 150 Soviet cities.<sup>65</sup> Local shops and warehouses, which monitored consumer preferences through conferences and exhibitions of goods, assisted VNIKS branches.<sup>66</sup> While VNIKS was beginning, a group of socio-economic researchers at Department No. 8 of VNIITE (which dealt with consumer product design) prepared a precise methodology for consumer research, aiming to advise special artistic-engineering bureaus and designers at factories under VNIITE's supervision. This methodology would be a necessary guide for designing any new object. Trade organisations, too, would need to rely on this methodology in their investigation of consumer preferences because their currently used methods were, according to the VNIITE group, poor (for example, questionnaires were inconsistent and included vaguely formulated questions).<sup>67</sup> Instead, the designers suggested a concrete yet flexible methodology that did not aspire to be the ultimate source of information on consumer preferences (and which could be combined with other sources, such as statistics on marketing) and recognised the fluidity of the category 'consumer group' ('they can change, transfer from one type to another, or disappear').<sup>68</sup> According to the institutional report, this was the first comprehensive, theoretically informed and practically useful methodology for studying consumer demand in the Soviet Union.

The concrete methods the designers proposed can be summarised as follows. A necessary preliminary step was the collection and analysis of data from statistical institutions, trade organisations, wholesale fairs, shoppers' conferences and the press. The next step would include different types of polling: questionnaires with open and closed questions, interviews and panel surveys, as well as distributing new models of goods to small groups of consumers for temporary use. The results would be translated into computer coding at so-called machine-calculating stations, expressed in percentages and arranged in correlation tables. From there they could be examined along with the quantity of production of consumer goods and analysed with different consumer characteristics in mind (age, gender, occupation, etc.) and arranged again in 'tables of preferences'. This analysis would then be used to determine consumer tendencies and, ultimately, establish a universal system of guidelines for all Soviet design organisations.<sup>69</sup> Thus, VNIITE took what was conventionally called the 'constantly growing material and cultural demands of the Soviet people' very seriously. A diversity of needs, processed, systematised and comparatively analysed, would become an instrument for ordering things. As the report explained, consumer research was the necessary foundation for designing 'objects with a definite aim' (*predmetov s opredelennym adresom*) rather than 'objects as such' (*predmetov voobshche*).<sup>70</sup> Objects that responded to specific, carefully examined needs would not end up

unused in warehouses. In this way the VNIITE research group resolved the contradiction between the state's promise to satisfy consumer needs and the design experts' urge to teach consumers good taste: popular needs, organised through a clear taxonomy, would become the guidelines for intelligent and rational consumption.

As an example, the report included a poll about household appliances, aimed at optimising the varieties of this type of household objects. The poll, consisting of five multiple-choice questions on preferred types of appliances, their quantity per household, and the type of domestic labour that most needed mechanisation, was published on 25 July 1965 in the newspaper *Nedelia (Week)*, a daily appendix to the official government periodical. The poll was far from representative; only 1,751 people participated (though they answered on behalf of their families), predominantly technical specialists and civil servants. However, it signified an important move towards giving consumers a say in the design of the objects they used every day.<sup>71</sup>

### Evaluating objects

Consumer research allowed designers to decipher consumers' requirements for commodities to a certain degree. According to technical aesthetics, these requirements predominantly defined quality. The Department of Engineering Evaluation at VNIITE promoted quality as 'the reflection of the level and character of the requirements' given to an object, rather than the result of this object's natural characteristics. In evaluating prototypes or already produced objects, designers should first of all determine the degree of correspondence between 'the interest of a person as a consumer and the interests of society as a producer'.<sup>72</sup> Thus, technical aesthetics presented quality as an indicator of an object's social function: harmonising the relationship between the individual and socialist society.

Expert evaluation (*ekspertiza*) was a significant part of VNIITE's work and a necessary complement to design. Its three major goals were to inform industries about the adequacy of their current products in relation to the requirements of consumers; to define the principles of technical aesthetics in product design; and to further the rationalisation of varieties of goods. In short, expert evaluation was a cornerstone of the process of ordering things. In its manual for the expert evaluation of industrially produced objects, the Department of Industrial Evaluation at VNIITE admitted that determining quantitative measures for product quality was still a work in progress. However, they believed that a combination of sociological research, laboratory and in situ testing, consultation between different specialists, and the designer's artistic intuition would provide a good basis for the expert evaluation of products even in the absence of a rigid quantitative methodology.<sup>73</sup>

For a non-quantitative evaluation, the VNIITE guidelines suggested 'generalised quality criteria' conventionally divided into sociological, operational and aesthetic aspects. Each aspect presupposed a specific set of questions. For each specific object and for each type of expert evaluation a different set of questions would be of major importance.

The first group of questions concerned the social characteristics of an object: how necessary is the object for fulfilling a social need? If it is an object for personal consumption, how does it compete with public services for satisfying needs, how does it further the development of these services or rationally complement them? The question about the object's ability to satisfy specific needs no less adequately than public services is particularly notable. This formulation suggests a compromise between the collectivisation of everyday life, revived from the 1920s and conceptualised by the Party as 'service in the culture of daily life', and the large-scale building of individual family flats with furnishings that made domestic labour more convenient. According to the Third Party Programme, adopted in 1961, the development of more home appliances to ease housework (especially for women) should be a temporary measure before the full switch to 'public forms for satisfying the material-everyday needs of a family'.<sup>74</sup> In 1966 urban planning organisations in Moscow estimated that institutions such as public canteens, laundries, repair stations, nurseries and kindergartens would double in number in the capital city by 1969.<sup>75</sup> Yet VNIITE designers were cautious about dismissing the importance of commodities for individual homes. In the introduction to the aforementioned 1965 poll, the design team from Department No. 8 admitted that, however important the development of public services was, they would not suit everyone universally and it would take time before many people could get used to them. The switch to public services would not eliminate the problem of keeping the home tidy, and cleaning services who came to flats would need customised appliances. In addition, home cooking was considered a pleasure in its own right (though the VNIITE guidelines present it as one specific to housewives).<sup>76</sup> Considering the development of housing and urban planning in the 1960s, the position of a commodity in relation to the material structure of public services was a significant evaluation criterion for VNIITE experts. Consumer opinion research played an especially important role in this part of the evaluation.

The second set of questions in the 1967 VNIITE guidelines related to the technical and operational aspects of goods' quality. These were categorised within three different relationships: object-person (questions of safety, ergonomics, hygiene, durability, psychological effect), object-object (the object's role as a tool for maintaining another object, as in the case of a vacuum cleaner and a carpet) and object-environment (the choice of materials, the interaction between several related objects, the problem of storage and climate conditions for the object's function-

ing). This part of the evaluation required a particularly interdisciplinary approach involving different specialists – engineers, technicians, psychologists, physicians and economists.

Finally, the third group was comprised of questions on the aesthetic effects of an object on both its producers and its consumers. In the case of producers, the aesthetic effect was presented as a producer's emotional satisfaction with the harmonious proportions of an object, the rational choice of materials, convenience of assembly and operation and the clarity of the smallest details. The aesthetic feeling of a producer was described as being determined by the labour process. When it came to a consumer, the VNIITE manual recognised two components of an object's aesthetic effect. The first was a by-product of the object's social significance, functionality, user-friendliness and the quality of its construction (*konstruktsiia*, a term borrowed from 1920s Russian Constructivism meaning the essential and sufficient structure of an object). The second component of an object's aesthetic effect was an elusive 'artistic fullness' (*khudozhestvennaia polnotsennost*) with no definition. Both the producer and consumer based their aesthetic evaluation of an object on 'subjective judgements about the object's objective characteristics'. The consumer's evaluation depended on his or her social status and preferences (the manual gave no similar specification for the producer).

This sophisticated guidance for expert evaluation required interdisciplinary cooperation between the designer, engineer, ergonomics specialist, sociologist, technician, medical expert and economist. The result of the evaluation, if successful, would reveal the interrelations and coherence between an object's different characteristics.<sup>77</sup>

In practice, however, some of the stages or aspects of an evaluation could be skipped, depending on the character of the object in question. For example, in its evaluation of domestic tape recorders produced in the USSR in 1966, the same Department of Industrial Evaluation provided a detailed evaluation of their technical characteristics, but barely approached the social and aesthetic aspects of the objects.<sup>78</sup> Obviously, in the mid to late 1960s, ordering things was still a work in progress: a painstaking, sophisticated project, riddled with vague concepts and technical and organisational discrepancies. Therefore, evaluation guidelines produced by VNIITE at this time demonstrate on the one hand a striving for clarity and, on the other, a tendency for excessive, even messy, specifications.

### Artistic-engineering elaborations

The guidelines for designing new consumer goods at VNIITE were called 'artistic-engineering elaborations' (*khudozhestvenno-konstruktorskie razrabotki*, KhKR for short). In the Leningrad branch of VNIITE (LF VNIITE),

the enthusiastic researcher Vsevolod Medvedev took the lead on KhKR. He presented a detailed algorithm for KhKR in 1966 with four major stages: first, research into the sociological literature on consumption, foreign product models, existing varieties and consumer demand; then, sketch designs (*eskiznoe proektirovanie*), accompanied by consultations with customers and relevant experts; next, technical design (*tekhnicheskoe proektirovanie*), that is, figuring out the details of objects and preparing sketches and mock-ups for discussion at VNIITE's artistic-technical council and subsequent demonstration to the customer; and, finally, the mass production of the designed object.<sup>79</sup> While this algorithm included multi-level analysis of technological, functional, economic, ergonomic and aesthetic factors, user preferences were conspicuously absent. As a prominent Leningrad VNIITE designer, Mikhail Kos'kov, later commented, in KhKR 'a human being was considered in the tradition of functionalism: first, predominantly from an engineering, rationalistic point of view, ignoring their personal, spiritual needs, and, second, on average, as a person fitting into norms'.<sup>80</sup> This was not a specifically Leningrad feature: as Diana West has demonstrated, human agents appeared as little more than extensions of rational systems or were altogether neglected in many Soviet design projects of the 1960s and later.<sup>81</sup> The Soviet order of things envisioned in the 1960s, therefore, neglected not only thing-power – the force of things beyond human comprehension – but also the individual agency of a consumer, notwithstanding the official rhetoric about 'satisfying the constantly growing demands' of people.

In terms of the concrete application of KhKR, one of the major works of Leningrad VNIITE was the design of standard sets of kitchenware for the model flat, worked out in 1965–66 by Moscow VNIITE in collaboration with the Central Research and Project Institute for Housing and Public Buildings and other construction institutions.<sup>82</sup> This project demonstrates the Soviet aesthetic regime of arts: a seemingly banal theme, kitchenware, was one of the entries for the Soviet Union in the international debate concerning modernity. Recent scholarship has revealed the kitchen's critical role in the history of the twentieth century: as a laboratory of modernisation, a showcase of advanced technology and consumption, a space for embodying gender stereotypes, and a battleground of economic systems and ideologies. The debate between Nikita Khrushchev and US Vice-President Richard Nixon in front of General Electric's model kitchen at the American National Exhibition in Moscow in 1959 has become an iconic image of the Cold War.<sup>83</sup> In a special volume devoted to mid-century kitchen design, Ruth Oldenziel and Karin Zachmann presented the kitchen 'as a complex, technological artefact that ranks with computers, cars, and nuclear missiles', and more specifically, as 'the sum total of artefacts, an integrated ensemble of standardised parts, a node in several technological systems, and a special arrangement'.<sup>84</sup> In Soviet society under

Khrushchev, the modern kitchen was an integral part of the mass housing campaign and the site for implementing promises on technological progress and material abundance (the Moscow Pioneer Palace, discussed in [Chapter 1](#), included a modern kitchen where girls were trained in housewifery). According to the results of a questionnaire conducted by the central VNIITE in 1965, cooking was the most time-consuming burden on Soviet housewives, and it was expected to be mechanised first of all.<sup>85</sup> While utopian visions of the total collectivisation of cooking and dining, echoing those of the 1920s, appeared in the press,<sup>86</sup> a housewife's labour in the kitchen – now increasingly more often an individual, rather than communal, kitchen – was a ubiquitous reality. It needed to be maximally rationalised and automated, and, accordingly, the kitchen was presented in popular journals and household literature as a modern workshop, akin to the site of industrial production. VNIITE took the kitchen of a prefabricated flat as a proper testing ground for ordering things.

The Leningrad design team, headed by Medvedev, painstakingly passed through the three stages of the KhKR of kitchenware typology. First, they examined the latest Western literature on household management and kitchenware models (mostly British, French and West German sources), opinion polls undertaken by trade organisations, and the variety of kitchenware previously developed by the Central Research Institute of Housing (*TsNIIEP zhilishcha*), as well as the (uncoordinated) kitchenware production of Soviet factories. Second, on the basis of this research and consultation with an economist and art critic, Moisei Kagan, they created a typology of dimension-types (*tiporazmerov*) of kitchenware objects.<sup>87</sup> Third, they prepared detailed technical drawings and mock-ups with an eye to the current and potential production of relevant materials. This KhKR was focused on a kitchenware set for a family of 3–4 people, which was to complement a particular project for a kitchen furniture set, run in parallel at Moscow VNIITE. One set was made from polished aluminium, another from enamelled steel. According to the KhKR report, the kitchenware would fit the kitchen furniture perfectly so that space in the kitchen would be used effectively. Contrary to the conventional classification of kitchenware that was based on the type of material and the technology involved in production, Medvedev's team used a classification based on the specific labour processes in the kitchen, such as washing and cutting foodstuffs, different methods of cooking (boiling, frying, steaming, baking, etc.), and the storing of food. For the sake of space (and of course raw materials used in production), designers proposed multi-purpose pots into which different pannikins (*vkladyshti*) could be inserted for preparing different meals or boiling milk. All the modelled kitchenware had rational, concise forms, with functional details embodied in decorative elements. In the aluminium set, all of the lids' surfaces were heat-protected and decorated with colour anodising. This method followed Western examples



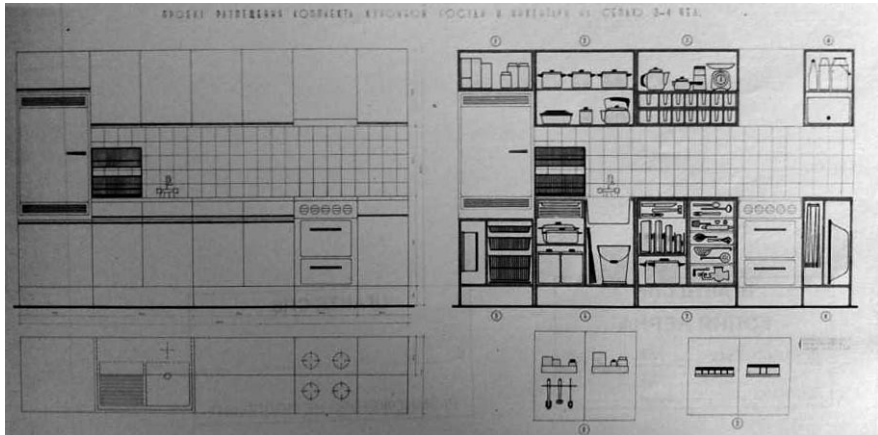

All rights reserved and permission to use the figure must be obtained from the copyright holder.

**2.2** Vsevolod Medvedev et al., project for an array of kitchenware and implements for a family of 3–4 people, 1966.

and would have been an innovation in the USSR. Suggesting various colours for anodising – from yellow to turquoise – the designers argued: ‘The addition of colour to the cold surfaces of polished ware, emphasized by the black spots of [plastic], significantly enriches its liveliness.’<sup>88</sup> This solution would meet consumer demand for ‘bright and trim kitchenware’, as indicated by opinion polls. Another technical innovation with decorative effect, chromium-plated polished rims, would be used in the enamelled set: ‘White or coloured enamel, accentuated by shiny edging, makes an item more expressive.’<sup>89</sup>

In addition to the kitchen tools, the prepared food was also supposed to be beautiful. Such items as vegetable or egg slicers (with thin wires for slicing) would make meals more aesthetically appealing, diversifying the domestic menu and, ultimately, stimulating healthy digestion. Of course, hygiene and economy, too, acted as important factors in design. Simple standardised plastic boxes with tight lids for storing different foodstuffs would impede the rotting or drying of food. Boxes for marinades would have square shapes with rounded corners for the convenience of washing. In the aluminium set, it would be technically impossible to put the teapot for brewing tea over the teapot for boiling water, as was customary in pre-revolutionary Russia and was still, evidently, practised by many in the 1960s. The project’s authors characterised this method of tea-making as unhygienic, so the very forms of the designed items were meant to preclude it. Thus, the varieties offered appeared up-to-date in terms of materials, technologies, colour combinations and hygienic standards. This vision of up-to-date design was presumed to be universally applicable, regardless of aspects such as individual social behaviour, culinary habits, ethnic/cultural identities or aesthetic views. The designers’ suggestion

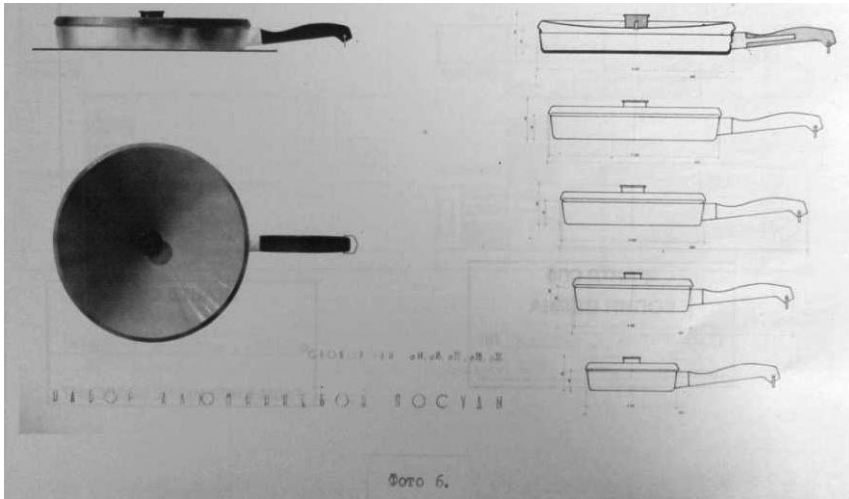

All rights reserved and permission to use the figure must be obtained from the copyright holder.

**2.3** Vsevolod Medvedev et al., technical drawing of aluminium kitchenware, 1966.

of selling the kitchenware not only in sets but also as separate items ‘to give consumers the opportunity to select sets according to their individual needs’<sup>90</sup> was a small step towards consumer flexibility.

However, the fourth stage of this KhKR was not successfully fulfilled. Medvedev’s team envisioned that the set would be most in demand among the many new inhabitants of prefabricated flats and that, unlike current kitchenware items, the new ones would not go unsold. It was planned to produce a pilot lot of 3,000–5,000 sets to more precisely determine the economic efficiency of these new varieties.<sup>91</sup> The guidelines for putting the design into production were prepared by 1968 and sent to several Leningrad factories.<sup>92</sup> The designers were ready to make compromises in terms of materials. However, the factories refused all their suggestions because they lacked the necessary materials and technological capabilities. The designers went to Vilnius and Kaunas in an attempt to establish agreements with local factories but found only limited success: the Kaunas factory Pirmunas agreed to select some pieces for production. Due to the failure to establish proper contracts with industry, Leningrad VNIITE discontinued work on these rational kitchenware sets.

Though the Leningrad kitchenware project never reached Soviet consumers, it can still be evaluated as having symbolic significance as an ultimate rejection of the chaos of forms. Unlike actually produced kitchenware that was in danger of going unused, VNIITE’s shiny pots and pans with ergonomic handles, transparent containers for grain and colourful jars for tea and coffee remain as pure concepts of eternally relevant socialist objects, and as documents of the designers’ painstaking attempts

to harmonise everyday consumption. KhKR in general can be seen not as a utopian undertaking that was impossible to implement in a rigid planned economy, but as a particular mode of making sense of the multiplicity of Soviet objects and of creating hierarchies of things and uses – ‘objectively defining the necessary and sufficient minimum of items, capable of providing a contemporary level of comfort’.<sup>93</sup> It was, therefore, an expressive element of what Serguei Oushakine calls ‘Soviet productivism’ – a cultural practice of late socialism that echoed the ideas of the 1920s theorists and focused on rationalising the relations between sensuous characteristics, forms and the social functions of things.<sup>94</sup>

## Conclusion

By the mid-1950s the rapid changes in everyday life had brought architectural reform and the mass housing campaign, and revealed the great discrepancy between the production of consumer goods, consumer needs and the Soviet Union’s aspiration to be an important participant in the development of modern culture and social policies internationally. On the level of material culture, this discrepancy revealed itself in the chaos of forms. While theorists were painstakingly developing a language to classify everyday objects, the state needed a smooth production of desirable commodities to fulfil its promises. Therefore, aesthetic considerations shrank to a modest component of a large, complex system of quality criteria that went far beyond the traditional realm of ‘art’. Classifiable and evaluable things would become easily updatable objects, suitable to a limited variety of homes and tastes. A well-designed Soviet kitchen represented a seamless web of social, technical and aesthetic perfection that could be easily tailored to the tastes of a few social groups. However, this restrictive vision became outdated as soon as it appeared. As I will demonstrate in the following chapters, the order of Soviet things was doubted by its very creators.

## Notes

- 1 A. Piletskii, ‘Pribory i mebel’, *Dekorativnoe Iskusstvo SSSR* 3 (1964), 24.
- 2 *Ibid.*, 25.
- 3 This standard formulation, recurrent in Soviet official documents and press of the 1960s, first appeared at the XXIst Party Congress in 1959. ‘Kontrol’nye tsifry razvitiia narodnogo khoziaistva na 1959–1965 gody’, in *Vneocherednoi XXI sezd kommunisticheskoi partii Sovetskogo Soiuza: 27 ianvaria-5 fevralia 1956 goda. Stenograficheskii otchet. Vol. 2* (Moscow: Gosudarstvennoe izdatelstvo politicheskoi literatury, 1959), pp. 456–549, 485.
- 4 Iurii Gerchuk, ‘The Aesthetics of Everyday Life in the Khrushchev Thaw in the USSR (1954–64)’, in Reid and Crowley (eds), *Style and Socialism*; Smith, *Property of Communists*; Harris, *Communism on Tomorrow Street*; Chernyshova, *Soviet*

- Consumer Culture in the Brezhnev Era*; Varga-Harris, *Stories of House and Home*; Anna Alekseyeva, 'Constructing Soviet Domesticity and Managing Everyday Life from Khrushchev to Collapse', in Roberts (ed.), *Material Culture in Russia and the USSR*, pp. 55–70.
- 5 Denis Kozlov and Eleonory Gilburd, 'The Thaw as an Event in Russian History', in Denis Kozlov and Eleonory Gilburd, *The Thaw: Soviet Society and Culture during the 1950s and 1960s* (Toronto: University of Toronto Press, 2012), p. 44.
  - 6 *Ibid.*, p. 42.
  - 7 Elizabeth A. St. Pierre, Alecia Y. Jackson, and Lisa A. Mazzei, 'New Empiricisms and New Materialisms: Conditions for New Inquiry', *Cultural Studies ↔ Critical Methodologies* 16.2 (2016), 102, doi:10.1177/1532708616638694.
  - 8 *Ibid.*, 103.
  - 9 *Ibid.*, 104.
  - 10 Bennett, *Vibrant Matter*, p. xvi.
  - 11 Iurii Soloviev, 'O tekhnicheskoi estetike', *Tekhnicheskaiia Estetika* 1 (1964), 1.
  - 12 Cybernetics is an interdisciplinary field, founded by the American scientists Norbert Wiener, Warren Sturgis McCulloch and others in the late 1940s and focused on elaborating theories of control and communication in animal and machine behaviour.
  - 13 West, 'CyberSovietica', p. 18.
  - 14 Margareta Tillberg, 'Made in the USSR: Design of Electronic/Electrical Systems in the Soviet Union from Khrushchev's Thaw to Gorbachev's Perestroika', *Baltic Worlds* 3.2 (2010), 38.
  - 15 Tillberg, 'Made in the USSR', 261
  - 16 Michel Foucault, *The Order of Things: An Archaeology of the Human Sciences* (New York: Vintage, 1994).
  - 17 Martin Heidegger, 'The Thing', in Martin Heidegger, *Poetry, Language, Thought* (New York: HarperCollins, 1971), pp. 174–5.
  - 18 Bill Brown, 'Thing Theory', *Critical Inquiry* 28.1 (2001), 4–5.
  - 19 Bennett, *Vibrant Matter*, p. 5.
  - 20 Moisei Kagan, 'O spetsifike i sushchnosti prikladnogo iskusstva', *Iskusstvo* 1 (1956), 16–21.
  - 21 Ivan Matsa, 'Mozhet li mashina byt' proizvedeniem iskusstva?' *Dekorativnoe Iskusstvo SSSR* 3 (1961), 14–16.
  - 22 Matsa, 'Mozhet li mashina', 16
  - 23 Tretiakov, 'Biografiia veshchi', 68–72.
  - 24 Nikolai Tarabukin, *Ot Mol'berta k mashine* (Moscow: Rabotnik Prosveshcheniia, 1923), pp. 21–3.
  - 25 A. Gorpenko, 'Iskusstvo I tekhnika', *Dekorativnoe Iskusstvo SSSR* 4 (1961), 25–7.
  - 26 *Ibid.*, 26
  - 27 *Ibid.*, 27.
  - 28 B. Shragin, 'Protiv privychnykh predstavlenii', *Dekorativnoe Iskusstvo SSSR* 5 (1961), 26–7.
  - 29 K. Kantor, 'Gde zhe granitsa prikladnogo iskusstva?' *Dekorativnoe Iskusstvo SSSR* 6 (1961), 21–3.
  - 30 IU. Gerchuk, 'Mashina kak proizvedeniie promyshlennogo iskusstva', *Dekorativnoe Iskusstvo SSSR* 2 (1962), 31–3.
  - 31 'K itogam diskussii: 'mozhet li mashina byt' proizvedeniem prikladnogo iskusstva?', *Dekorativnoe Iskusstvo SSSR* 12 (1962), 23–4, 45.
  - 32 *Ibid.*, 23.
  - 33 *Ibid.*, 24.
  - 34 See interviews with former VNIITE designers conducted by the curators of the Moscow Design Museum in 2012 on the museum's YouTube channel, [www.youtube.com/user/MoscowDesignMuseum](http://www.youtube.com/user/MoscowDesignMuseum) (accessed 2 August 2019). Irina Kostenko,

- director of VNIITE's design centre that operated from 1975, shared a memory of 'design' as a strictly forbidden word at the conference '(De)Constructing Utopia: Design in Eastern Europe from Thaw to Perestroika', Sheffield University, 2–3 May 2014.
- 35 Larisa Zhadova, 'O terminogogii i poniatiakh v sfere promyshlennogo iskusstva', *Tekhnicheskaiia Estetika* 7 (1964), 14–17.
  - 36 TsGALI SPb, f. 7, op. 1, d. 38.
  - 37 Runge, *Istoriia dizaina, nauki i tekhniki*, p. 285.
  - 38 RGALI, f. 2460, op. 2, d. 220.
  - 39 Runge, *Istoriia dizaina, nauki i tekhniki*, p. 285.
  - 40 Zhadova, 'O terminogogii i poniatiakh v sfere promyshlennogo iskusstva', 15–16; Mikhail Kos'kov, interview with the author, recorded in St Petersburg on 16 April 2011.
  - 41 Khan-Magomedov, *Pionery sovetskogo dizaina*, p. 383.
  - 42 Although it was not mentioned by Zhadova in her talk, the term *khudozhestvennoe konstruirivaie* was sometimes used by the constructivists in the 1920s. See Lodder, *Russian Constructivism*.
  - 43 Zhadova, 'O terminogogii i poniatiakh v sfere promyshlennogo iskusstva', 14–17.
  - 44 Russian State Archive of Scientific and Technical Documentation, Moscow (hereafter RGANTD), f. R-688, op. 1–1, d. 57, l. 21. I am thankful to Tom Cubbin for sharing the archival location of this document.
  - 45 David Raizman, *History of Modern Design: Graphics and Products since the Industrial Revolution* (London: Laurence King Publishing, 2003).
  - 46 Simon Bojko, 'Na tretiem kongresse IKSIDA', *Dekorativnoe Iskusstvo SSSR* 11 (1963), 23–48; 'Un esprit de l'Industrial design? Icsid Paris 1963', *Design et Histories, Le blog de Jocelyne Leboeuf*, 6 January 2013, <http://blogs.lecolededesign.com/design/ethistoires/2013/01/06/un-esprit-de-lindustrial-design-icsid-paris-1963/> (accessed 10 December 2017).
  - 47 Evgenii Rozenblium, 'Problemy dizaina', *Dekorativnoe Iskusstvo SSSR* 1 (1966), 2–5.
  - 48 Raizman, *History of Modern Design*, p. 240.
  - 49 Soloviev, 'O tekhnicheskoi estetike', 2.
  - 50 Raizman, *History of Modern Design*, p. 240.
  - 51 G. Liubimova, 'Veshchi v dome', *Dekorativnoe Iskusstvo SSSR* 8 (1965), 2–5.
  - 52 Ia. Orlov, 'Tsena plokhogo kachestva', *Tekhnicheskaiia Estetika* 1 (1964), 27–9.
  - 53 RGANTD, f. R-688, op. 1–1, d. 57, l. 4.
  - 54 RGANTD, f. R-688, op. 1–1, d. 57, ll. 5–8.
  - 55 RGANTD, f. R-688, op. 1–1, d. 57, ll. 24–5.
  - 56 Aleksandr Riabushin, 'Zadachi i sposoby opredeleniia bytovogo oborudovaniia', *Tekhnicheskaiia Estetika* 6 (1966), 3–5.
  - 57 Anatolii Piskoppel', 'G. P. Shchedrovitskii – podvizhnik i myslitel', in N. I. Kuznetsova (ed.), *Poznaiushchee myshleniie i sotsial'noe deistviie. Nasledie G. P. Shchedrovitskogo v kontekste otechestvennoi i mirovoi sotsial'noi mysli* (Moscow: F. A. S.-media, 2004), 24–4.
  - 58 Reid, 'Khrushchev Modern', 251.
  - 59 Literary critic and journalist Aleksandr Arkhangel'skii outlined in a public lecture on Soviet philosophy that the establishment of an institute was a matter of chance. Grushin, a graduate of the Philosophy Department of Moscow State University, could not find a position in research or teaching because of his difficult character and thus ended up as the head of the department of readers' letters of *Komsomol'skaia Pravda*. Thus, he devised an institute of public opinion as an outlet for his intellectual ambitions. Arkhangel'skii probably drew the information about Grushin's personality from informal communications with Grushin himself (who was thirty-three years older and died in 2003) or his colleagues or pupils. Aleksandr Arkhangel'skii, 'Nesovetskaia filosofiia v SSSR' (online course),

- educational website Arzamas, 5 March 2015, <http://arzamas.academy/courses/1/2> (accessed 25 January 2018).
- 60 Boris Grushin, 'Institut obshchestvennogo mneniia 'Komsomol'skoi Pravdy', *Monitoring obshchestvennogo mneniia* 1.63 (January-February 2003), <https://cyberleninka.ru/article/v/institut-obshchestvennogo-mneniya-komsomolskoy-pravdy> (accessed 25 January 2017).
- 61 Foreign sources for the methods of consumer research are listed in the VNIITE report from 1965: RGANTD, f. R-688, op. 1–1, d. 122, l. 37.
- 62 V. Shvili, 'Chto daiut konkretno-sotsiologicheskoe issledovaniia promyshlennosti I torgovle', *Tekhnicheskaiia Estetika* 2 (1965), 1–2.
- 63 *Ibid.*, 2.
- 64 Serguei A. Oushakine suggests translating the institute's exact name as the All-Union Research Institute for the Study of Popular Demands for Commodities of Popular Consumption, and of Commerce (*Vsesoiuznyi nauchno issledovatel'skii institut po izucheniiu sprosa naseleniia na tovary narodnogo potrebleniia i kon'iukhtury torgovli*, VNIKS).
- 65 Serguei Alex Oushakine, "'Against the Cult of Things": On Soviet Productivism, Storage Economy, and Commodities with No Destination', *Russian Review* 73.2 (2014), 251.
- 66 Chernyshova, *Soviet Consumer Culture in the Brezhnev Era*, p. 26.
- 67 RGANTD, f. R-688, op. 1–1, d. 122.
- 68 RGANTD, f. R-688, op. 1–1, d. 122, l. 11.
- 69 RGANTD, f. R-688, op. 1–1, d. 122, l. 13–36.
- 70 RGANTD, f. R-688, op. 1–1, d. 122, ll. 11, 40.
- 71 RGANTD, f. R-688, op. 1–1, d. 85.
- 72 *Metodicheskie ukazaniia po provedeniiu ekspertizy promyshlennykh izdelii s pozitsii tekhnicheskoi estetiki* (Moscow: VNIITE, 1967), pp. 5–6.
- 73 *Ibid.*, p. 14.
- 74 *Programmema Kommunisticheskoi partii Sovetskogo Soiuza* (Moscow: Politizdat, 1961), <http://museumreforms.ru/node/13891> (accessed 13 April 2018).
- 75 V. A. Nesterov and A. Ia. Kovalev (eds), *Arkhitektura: Raboty proektnykh i nauchnykh institutov Moskv 1966–1969* (Moscow: Stroizdat, 1970), p. 169, cited in Cubbin, 'The Domestic Information Machine', 25.
- 76 RGANTD, f. R-688, op. 1–1, d. 122, ll. 11, 40–1.
- 77 *Metodicheskie ukazaniia*, pp. 14–18.
- 78 RGANTD, f. R-688, op. 1–1, d. 181. I am thankful to Tom Cubbin for sharing the archival location of this document.
- 79 Central State Archive of Scientific and Technical Documentation, St Petersburg (hereafter TsGANTD SPb), f. 146, op. 2–1, d. 78, ll. 13–16.
- 80 Kos'kov, *Predmetnoe tvorchestvo*, pp. 11–12.
- 81 West, 'CyberSovietica', p. 152.
- 82 TsGANTD SPb, f. 146, op. 2–1, d. 77.
- 83 Nicholas Bullock, 'First the Kitchen: Then the Façade', *Journal of Design History* 1.3/4 (1988), 177–92; Ruth Schwartz Cowan, *More Work for Mother: The Ironies of Household Technology from the Open Hearth to the Microwave* (New York: Basic Books, 1983); Ghislane Hermanuz, 'Outgrowing the Corner of the Kitchen Table', in Joan Rothschild and Alethea Cheng (eds), *Design and Feminism: Re-Visioning Spaces, Places, and Everyday Things* (New Brunswick, NJ: Rutgers University Press, 1999), pp. 67–84; Victoria de Grazia, *Irresistible Empire: America's Advance through Twentieth-Century Europe* (Cambridge, MA: Belknap Press of Harvard University Press, 2006); Susan E. Reid, 'The Khrushchev Kitchen: Domesticating the Scientific-Technological Revolution', *Journal of Contemporary History* 40.2 (2005), 289–316.
- 84 Ruth Oldenziel and Karen Zachmann, 'Introduction', in Ruth Oldenziel and Karin

Zachmann (eds), *Cold War Kitchen: Americanization, Technology, and European Users* (Cambridge, MA: MIT Press, 2011), pp. 1–32.

- 85 RGANTD, f. 281, op. 1–1, ed. khr. 85, ‘Social-Economic Research of Consumer Demands to the Tools Mechanizing Domestic Labor’, December 1965.
- 86 Aleksandr Riabushin, ‘Zhilishche novogo tipa’, *Dekorativnoe Iskusstvo SSSR* 2 (1963), 5–10.
- 87 The results of the second stage of the KhKR were presented in the press: V. Medvedev, ‘Assortiment kukhonnoi posudy’, *Tekhnicheskaiia Estetika* 6 (1966), 13–17.
- 88 TsGANTD SPb, f. 146, op. 2–1, d. 77, l. 36. Unfortunately, the archival file of this KhKR includes only black-and-white illustrations.
- 89 TsGANTD SPb, f. 146, op. 2–1, d. 77, l. 39.
- 90 TsGANTD SPb, f. 146, op. 2–1, d. 77, l. 58.
- 91 TsGANTD SPb, f. 146, op. 2–1, d. 77, l. 61.
- 92 TsGANTD SPb, f. 146, op. 2–1, d. 79.
- 93 Riabushin, ‘Zadachi i sposoby’, 3.
- 94 Oushakine, ‘Against the Cult of Things’.

# 3

## Objects of neodecorativism

'Art into Life' was not only the name of an important 1961 exhibition in Moscow, it was also a key phrase of Khrushchev-era art theory that contributed to the emergence of technical aesthetics. It informed the creative choices of those who defined themselves as 'decorative-applied artists': those who worked with such traditional materials as ceramics, glass, textiles, metal and wood, shaping them into modern socialist objects. Warning against turning technical forms into commodity fetishes and imitating the austerity of Western functionalism, Soviet art theorists of the 1950s tried to find a balance between beauty and utility, between artistic fantasy and mass reproducibility. This balance would guarantee the honesty that, as I argued in the first chapter, emerged as a chief criterion of a modern, post-Stalin socialist object.

Even before VNIITE took responsibility for 'fully satisfying the constantly growing material and cultural demands of the Soviet people',<sup>1</sup> applied artists (the term I prefer for this profession in the Khrushchev period) used their work's connection to everyday life as the main argument for their highly important status in the Soviet artistic community. In their address to the First All-Union Convention of Artists, the *prikladniki* (as applied artists were colloquially called) of Leningrad asserted:

The ideological-artistic significance of this [applied] art is in no way smaller than that of painting or sculpture, for it has a much greater mass scale, it surrounds a person in her daily life. In addition, the interest, provoked by Soviet decorative-applied art at Soviet and international exhibitions, is widely known. Therefore, the neglect of the needs of decorative-applied art is, in fact, neglect of the needs of our people, and the problems of this art are strictly political.<sup>2</sup>

The practical everyday needs of people legitimised and justified the needs of an artist. Alongside the emerging 'artist-engineers', applied artists



employed in factories and in different subsidiaries of the Art Fund assumed the role of taste experts and guides for rational consumption.<sup>3</sup> In this respect, the state's commitment to raising living standards met the artists' professional ambitions and personal beliefs.

This confluence of interests between the state and applied artists gained momentum by the end of the 1950s. In his address to the readers of *Dekorativnoe Iskusstvo SSSR* in January 1960, Minister of Culture Nikolai Mikhailov stated that 'the whole army of Soviet artists', together with the media, should propagate the best prototypes of commodities and educate mass taste.<sup>4</sup> A few pages later, the journal's editorial board announced a new rubric for the 'reviews of objects'.<sup>5</sup> Just as reviews of theatre performances or films kept the public informed about new releases, these 'reviews of objects' were intended to educate consumers about new goods that met the standards of beauty, utility, affordability, durability and so on – in short, that would be close to the ideal of a socialist object, elaborated by theorists such as Aleksandr Saltykov. The next issue of the journal opened with an address to the State Planning Committee (Gosplan) concerning the urgent need to open an all-Union 'Institute of Artistic Culture', which was co-signed by the first secretary of the USSR Artists' Union board, Sergei Gerasimov; the president of the Academy of Arts of the USSR, Boris Ioganson; the chair of the organising committee of the Russian Socialist Republics' Artists' Union, Vladimir Serov; and the chief editor of *Dekorativnoe Iskusstvo SSSR* (and the chief urban designer of Moscow), Mikhail Ladur. Reiterating the call for the education of the public's tastes, these representatives of the Soviet art establishment declared: 'we want to actively help the Party in the everyday process of building a bright new life'. The organisation that they proposed would be the best institutional method of achieving this goal: it would 'practically help economic organisations of industry, transport and construction to elaborate the most expedient projects for the decoration of facilities and prototypes of different objects that were simple, cheap and beautifully designed'.<sup>6</sup> This institute would involve specialists of different profiles. This proposal was evidently later combined with Iurii Soloviev's initiative, inspired by the British example, in the establishment of VNIITE.

After the groundbreaking exhibition 'Art into Life', the applied artists who worked on contracts managed by the Art Fund or were employed in traditional enterprises of the art industry (textiles, glass and porcelain factories) or in the engineering bureaus of regional economic councils, tended to adhere to similar principles and pursue the same goal: improving the production of commodities. Honest, simple, mass-reproducible objects became the central concern of those who were trying to delineate the borders between art, technics and the everyday (*byt*). The establishment of VNIITE in 1962 seemed like the beginning of a system of clear principles and guidelines for all types of objects and for professionals of all affilia-

tions who designed them. At the beginning of the 1960s, applied artists and artists-engineers all assumed the role that Susan Reid calls ‘accredited taste professionals’: they were equipped with specialist knowledge and employed by the state to improve material culture and particularly the modern home.<sup>7</sup> This was the apogee of the Khrushchev-era aesthetic turn.

However, what followed this seemingly harmonious confluence of state and professional interests? While the material culture of the Thaw era has interested scholars for a long time, the post-Khrushchev changes have only recently been subject to scrutiny. In her recent study of Brezhnev-era consumer culture, Natalya Chernyshova poses the following question: ‘What happened after the energetic assault of Khrushchev’s design revolution?’<sup>8</sup> She identifies the conceptual change in art and design theory that occurred around 1965 and relates it to the heavy criticism of Khrushchev’s policies and promises, including the ideal of the modern home that he promoted with the help of professionals, after his removal from power. The design discourse after 1965 underwent what she calls ‘de-Khrushchevisation’, when the praise of standard interiors and rational objects was replaced by sensitivity to diversity of tastes and spirituality.<sup>9</sup>

How did this change from rationality to spirituality affect the ideal of the socialist object? Additionally, what happened to the position of applied artists as ‘accredited taste professionals’ at the point when the concept of a universal good taste disintegrated? In what follows, I will elaborate on Chernyshova’s argument by identifying an artistic tendency that emerged at the end of the Khrushchev period as a response and reaction to the state-sponsored campaign to modernise consumption and the home. Following the suggestion of the art critic Iurii Gerchuk, I call this tendency ‘neodecorativism’ – a set of artistic strategies to redefine the meaning of decoration and reconceptualise ‘decorative-applied’ art as decorative first and foremost.

This chapter follows the trajectory of neodecorativism. It initially scrutinises in more detail the earlier discussed notion of an ‘honest object’ and demonstrates a degree of complexity in the objects produced during the aesthetic turn (late 1950s to early 1960s). The chapter then goes on to identify the change in design professionals’ thinking regarding ideal objects and proper home making. Finally, it highlights the conceptual and material expressions of neodecorativism, using examples from critical articles and exhibitions. For the sake of convenience, and in accordance with this chapter’s argument, I will use the term ‘applied art’ for pre-1965 objects, and ‘decorative art’ for what came after the mid-decade conceptual change.

### Variations of ‘simplicity’

While an ideal object of the Khrushchev era was honest, simple, mass-reproducible and affordable, it was not plain. An attentive look would

reveal a degree of complexity. As art historian Galina Iakovleva argues, reducing objects to the basic functional elements, as was characteristic of the late 1950s and early 1960s, opened the possibility for focused contemplation and recognition of the ‘complexity behind simplicity’.<sup>10</sup> Drawing on this argument, I suggest noticing the variations within the tendency of decorative art towards simplification and rationalisation.

Objects such as carpets, curtains, ceramics and glass, produced in smaller or larger series by specialised factories, would act as vivid foci to accentuate the well-ordered minimalist interiors around them, a role of Soviet applied art often noted by art historians.<sup>11</sup> Just as electronic devices ought to differ strikingly from modular furniture, as the critic Piletskii suggested in 1964,<sup>12</sup> traditional applied art objects, too, should stand out in a standard modern flat. This would not be an intrusion, however, but rather harmonious integration, aimed at finding a perfect balance between tradition and modernity in the home. Summarising popular advice books of the late 1950s to early 1960s, Iakovleva demonstrates the dialectics of freedom and rigidity in the ideal of the modern Soviet home: while design professionals encouraged householders to ‘play’ with colours and textures, this ‘game’ had clear rules. For example, if one chose to ‘occupy the right part of a composition with a light-colour vertical object, one definitely had to place a low dark object to the left part, uniting the two parts with a contrasting background, matching the colour of a small cushion on a couch’.<sup>13</sup> Diversity, complexity and contrast were, therefore, elements of the Soviet modernist order of things, always to be managed through balance.

The principle of contrast could also be discerned *within* objects. An applied artist could pursue a contrast between a simple form and vivid (but not too sophisticated) decoration, between blank and decorated surfaces, between two different qualities of the same material. For example, the set of teapots ‘Tundra’ from the collection of the Moscow Museum (produced in 1959, factory unknown), demonstrates a temperate use of gilding to accentuate the structural elements (cover, handle, lid) and create modest ornaments out of figurative details (antlers) (plate 2). Even though the body of the pot is covered in a black overglaze pigment, the inherent whiteness of the porcelain is not obscured (this would be considered kitsch); rather it is emphasised through a schematic outline of a deer. The body of porcelain depicts the animal body; thus, the ‘honesty’ of the material is embodied in the decoration’s subject.

The objects produced in the early 1960s at the Leningrad Factory of Artistic Glass similarly demonstrate variations of contrast. Artistic glass of the Khrushchev era is often associated with simple transparent vessels, unornamented or with minimal geometric ornament. Boris Smirnov, a versatile artist and designer with experience of 1920s Constructivism, who joined the Leningrad Factory of Artistic Glass in 1949, praised exactly such objects eight years later: ‘Think about a thin, smooth, colourless drinking



*All rights reserved and permission to use the figure must be obtained from the copyright holder.*

**3.1** Leida Jurgen, water set, 'Strings', colourless lead glass, incising, 1962.

glass: it will never get boring, it is beautiful and pleasant exactly due to its simplicity [...] Ideally, all the objects of daily use should be like this.'<sup>14</sup> An example of such a minimalist glass object is a 1962 water service 'Strings', made from colourless lead glass by Smirnov's factory colleague Leida Jurgen, a graduate from the State Artistic Institute of the Estonian Socialist Republic. Its clear geometric forms and clusters of incised vertical lines for decoration serve as a good illustration of the late 1950s debates regarding realism, vibrancy and artistic image. A viewer can focus on the decoration that represents strings or on the functional forms of the vessels. Smirnov himself practised what he preached: he designed different functional forms of colourless glass. From 1959 he started experimenting with colourless decoration on lead glass through sandblasting.<sup>15</sup> The philosopher Andrei Troshin has recently compared transparent colourless objects to laboratory test-tubes. In his view, 'glass becomes but a raw material for the objects of particular forms subjected to utilitarian and strictly defined functions' due to the idealisation of transparency.<sup>16</sup>

However, it is unlikely that in their colourless decoration Smirnov and Jurgen were inspired only by test-tubes. Contrary to his 1957 pronouncement concerning the superiority of undecorated glass, Smirnov often leaned towards figurative and even literary decoration. Sandblasting, engraving and incising allowed him to visually inscribe figures in the body of an object, to play with the contrast of the different materials. In his well-known



*All rights reserved and permission to use the figure must be obtained from the copyright holder.*

**3.2** Boris Smirnov, vases, 'Glass Blowers', transparent lead glass, sandblasting, engraving; sandblasting by Helle Pyld and R. Antonenko, engraving by A. Soloviev, 1961–63.

service 'Orchestra' (1962–64), figures of musicians in dynamic poses as well as their instruments are cut into the thickness of lead glass. As a result, as two critics observed in 1965, the brilliance of faceting amplifies the perception of movement and probably even stimulates the viewer to imagine sounds. In another frequently cited artwork by Smirnov, a triptych of vases 'Glassblowers' (1961–63), the decoration refers to the process of making: unlike a constructivist object, where an artist's labour is imprinted in the clear structural form, Smirnov's object embodies a depiction of the labour process. Similarly, in her 1961 vase 'Kindergarten' with engraved images of children sleeping among the stars, Jurgen renders the immateriality of a dream through the materiality of transparent colourless glass.

It was often the case, however, that Leningrad glass artists avoided figurative ornament in favour of achieving contrast between different qualities of glass, such as full transparency and colour diversity, lightness and thickness of the facets. These combinations appear, for example, in a service 'Rainbow' which was designed by the factory's chief artist Ekaterina Ianovskaia (a 1949 graduate from Moscow Art and Industry School) in 1962 (plate 3), or in a 1961 piece by Jurgen's fellow graduate from the Estonian Art Institute, Helle Pyld. Smirnov, too, advocated the exploration of all the physical possibilities of glass for creating strong images as early

as 1954. In the late 1950s he approached his work with the idea of 'truth to materials': 'Considering the material as a means of embodying the ideal conception of the work, [an artist] should use its artistic and technological qualities to the maximum extent.' Providing an example of his favourite material, Smirnov explained: 'The main expressive qualities of glass [are achieved by] light: the refraction of light in facets; the condensation of light within glass; the free, almost unchanging, passage of light through glass; and the colouring of light through glass by almost any colour.'<sup>17</sup>

Another interest of Smirnov that complicates his role as an advocate of rational utilitarian objects was his attitude towards traditional glassmaking, particularly Ukrainian blown glass with hot applications (*gutnoe steklo*), in which *millefiori* (mosaic beads) were often used as decoration. Some of his works, produced at the factory as exhibition pieces (for example, the decanter 'Lady', 1957, the pitcher 'Horse', 1961, and others) demonstrate playfulness in the reinterpretation of folk tradition. Smirnov welcomed the appearance of such objects at exhibitions, because they revealed the creative individuality of each artist, but still prioritised simple forms and techniques for producing consumer goods for all. For example, pressing could be used to create rectangular shapes and simple decorative patterns of various configurations. Likewise, the method of thermal processing of zinc sulphide glass, developed by the factory's chief technologist Nikolai Kachalov, could be used to create an array of patterns, colours and textures and so produce cheap objects in great quantity.<sup>18</sup> In her 1961 review of Smirnov's versatile work as a glass artist, designer of optical tools, exhibition designer, graphic artist and book illustrator, the critic Nina Iaglova characterised him as first of all an 'artist of industry'. According to her, the most interesting aspect of Smirnov's work was 'his search for an impressive image in an everyday object of mass consumption, which he can poeticize by barely noticeable touches'.<sup>19</sup> One could characterise Smirnov's work in the 1950s and early 1960s as an exploration of the tension between rationality and expressivity.

Whether experimenting with colourless ornaments or contrasts between colour and texture, Leningrad applied artists exhibited a critical approach to the ideal of a mass-produced socialist object in their design philosophy, even if in public they embraced that ideal wholeheartedly. Similar examples of moderate experimentation could be found in other factories that produced traditional domestic objects. This emergent tension between rationality and expressivity would soon grow into a tendency that art critics could not ignore.

### 'Everything is much more complicated'

The first signs of the change in professional attitudes towards the design of domestic interiors emerged even before Khrushchev's resignation and his

successor's critique of his bold reformism. One of them was immediately connected to *Dekorativnoe Iskusstvo SSSR*. At the beginning of 1963, the art critic Leonid Nevler, commissioned by the journal's editorial board, undertook a 'field trip' to student and workers' dormitories in the town of Kalinin (now Tver) in order to learn about people's actual tastes in home furnishings and to give them specialist advice. The trip report was published in the journal's March issue.<sup>20</sup> What Nevler saw was far from the designers' vision of an ideal Soviet home. All dormitories had the following in common: 'first, a corridor system; second, the predominance of the colour brown; third, identical iron beds; fourth, identical milk-white, cone-shaped lampshades; fifth, the artistic and anti-artistic consequences of all this'. Yet there was a significant difference depending on the gender of the inhabitant: young men accepted these gloomy interiors as they were, whereas young women tried to make them cosier. In women's rooms, Nevler observed piles of cushions; coloured carpet strips over bed covers; red bows tied up to bed frames; postcards with flowers, kissing couples and movie stars pinned to cushions or on walls and bedside tables; artificial flowers; handmade cross-stitched embroideries (mostly kittens and flowers); figurines and kitten-shaped money boxes – the whole assortment of bric-a-brac that had been so frequently attacked by design professionals for the past decade.

However, instead of the usual condemnation of the remnants of petty-bourgeois taste, Nevler approached dormitory interiors as meaningful individual and social statements, or, as Bourdieu would have it, 'manifested preferences'.<sup>21</sup> He noticed that, first, the embroideries made by these women often showed 'an excellent sense of colour' and thus could not be dismissed as sheer kitsch. Second, the rooms' inhabitants proved not to be backward *meshchanki*, but 'quite modern women, with modern haircuts, in modern jumpers and convenient short trousers; jolly, nice, and independent'.<sup>22</sup>

Why did these artistically gifted people, with a taste for modern dress, decorate their homes in 'their grandmothers' fashion'? Nevler suggested that while the young women adhered to the requirements of their social environment (workplace, university, places for leisure activities) in their dress and behaviour, they recreated the atmosphere of their parental homes in their domestic space. Though the author does not articulate it clearly, the tone of his prose evokes the theme of social mobility: the transition from small villages and towns, where traditional ideas of domestic cosiness prevailed, to the bigger city with modern infrastructures of labour and leisure. Therefore, homemade decoration served as the means to settle in and adapt to the new urban and collectivised daily life. Rather than being tacky, Nevler argued, dormitory dwellers 'consistently and painstakingly' followed the tastes of their 'home environment' (*domashnei sredy*). Therefore, he suggested,

such widespread stylistic incongruity between the [residents'] attire and interiors is not only aesthetic, but also sociological and psychological. And it is absolutely meaningless (if not offensive) to equate outdated visions of domestic comfort [*nesovremennost'*] with philistinism [*meshchanstvo*] and grandparents' traditions with tastelessness, as some zealous journalists do. *Everything is much more complicated* [emphasis in the original].<sup>23</sup>

Moreover, Nevler suggested treating the popular method of dormitory decoration not as eclecticism, but as a specific style which, had it been the subject of an opinion poll, would prove to be popular in the USSR far beyond women's dormitories. If this style was loved by people, why should it be rejected, let alone destroyed? Nevler insisted that it should be taken seriously because it reflected real life and real values.

Nevler's article was the first manifestation of a move away from the dictatorship of taste towards the recognition of people's individual desires and preferences. However, rather than letting people enjoy what they preferred, Nevler suggested re-educating their tastes by removing old-fashioned knick-knacks from production and selling only brand new goods in urban stores. Additionally, he believed that old-fashioned domestication was prompted by the 'formal and bureaucratic' (*kazенno-biurokraticheskii*) style of dormitory interiors, with eclectic, clumsy furniture and dim, brown walls. Design professionals had to intervene and create 'modern, rational, and modest comfort' in homes that their inhabitants could truly appreciate. Nevler admitted that 'embroideries and kittens' would, probably, still be brought into modernised interiors, but less frequently over time. Here, he offered a sociological explanation for decoration choices: young women furnish their dormitory bunks in the way that they do because of a lack of information about modern alternatives, not because of any conscious choice to follow family traditions. In fact, Nevler noted that a dormitory (in Russian *obshchezhitie*, literally 'a place for communal living') is not a typical domestic environment, but rather a site of collectivism in much need of 'massive artistic intervention'.

The militarist rhetoric of Nevler's argument here contrasts strikingly with his earlier nuanced explanation of people's tastes, revealing the professional anxiety over social mobility and the growing youth culture at that time. While encouraging the youth's interest in Western fashion and certain elements of Western mass culture, designers and critics assumed the role of mediators in this process by publishing advice literature and shaping the spaces of socialisation, as in the spread of modern cafés heavily frequented by young people in the 1960s. Nevler, however, opined that such cafés attracted too much of designers' attention at the expense of the interiors of student and worker dormitories. These temporary homes, Nevler believed, could be excellent showcases of modern lifestyles precisely because they allowed for the greater intervention of design experts than family flats.<sup>24</sup>



Although still confident in professionals' capacity to regulate tastes and, through them, social hierarchies, Nevler clearly expressed his uncertainty in terms of the most efficient and ethical methods of doing this. Ironically noting how easy it is to criticise bric-a-brac, he concluded by blatantly questioning his colleagues: 'But can you offer something instead? Can you? Then why aren't you offering?'<sup>25</sup> A chorus of responses, repudiations, criticisms and revisions soon followed, which culminated in 1965, two years after the publication of Nevler's article.

### Towards more degrees of freedom

In 1965 *Dekorativnoe Iskusstvo SSSR* introduced an editorial – clearly modelled on the British journal *Design* – which became a platform for expressing doubts about the principles of modern Soviet design and offering solutions. In the very first editorial, Mikhail Ladur openly lamented the loss of the 'great mystery of art' in pursuit of rationality by 'the admirers of the aesthetics of numbers and compasses'.<sup>26</sup> 'Mystery' was no longer rejected as being fake or fetishistic but was instead seen as necessary for art to remain humanistic and responsive to people's complex emotions:

a true artist will never remove the outer covering of an image in order to show the harmony of ligaments, tendons and neurons of an object. So why does the naked function of our world of objects now claim the dominant place in our soul, why do I have to admire only the perfectly ideal harmony of a mathematical formula?<sup>27</sup>

A few months later, Ladur added that unified houses, flats and commodities implied unified consumers and thus jeopardised diversity, a fundamental characteristic of humanity. 'Our [Soviet] people are different, and we should not make them identical by means of art.'<sup>28</sup> Terms such as 'emotions', 'spirituality', 'depth', 'width', 'diversity' and 'complexity' became more frequent in *Dekorativnoe Iskusstvo SSSR* editorials over time, and often appeared in such open questions to its readers.

Moreover, many of the journal's articles on domestic interiors allowed for the agency of consumers in making their own decisions in organising their homes. Chernyshova interprets this tendency as evidence of the government's rejection of Khrushchev-era egalitarianism regarding taste and possessions, and as an example of the beginning of the 'Brezhnev-era domestic counter-revolution' that tolerated traditionalism and conservative tastes as opposed to modernist design ideals.<sup>29</sup> However, I suggest that design professionals were not entirely obedient enactors of the state's changing ideological guidelines. They were able to use the political and economic situation for their own benefit, initiating a debate over the relations between consumers and experts, and, through this, reflecting on fundamental questions of personal freedom. For example,

Viacheslav Glazychev, a connoisseur of Western industrial design, called readers' attention to the problem of home decoration in the May issue of *Dekorativnoe Iskusstvo SSSR* from 1966.<sup>30</sup> He recognised the dual nature of a home interior: standardised and yet individual. For him, this duality was a socio-psychological problem. As Glazychev admitted, even though Soviet people were more or less equal in terms of income, there existed different social strata defined by education, cultural habits, the prestige of one's profession, etc. These strata had varying tastes and consumer preferences, which could not be satisfied by standard domestic 'comfort'. However, Soviet people in general demonstrated the growing propensity for handmade home decorations, which echoed the similar trend in the capitalist West. Irrationality and spontaneity needed to be recognised as normal human traits. However, Glazychev argued, specialists ought not to let things go freely: 'designers need to elaborate a simple and effective system of small element-blanks [*elementov-zagotovok*] for assembling. Professional applied art and modernised folk crafts should provide a wide choice of irrational decorative objects.'<sup>31</sup> All the rest was up to the consumer. In Glazychev's view, specialists would be better to abstain from rigid recommendations. Instead, their job was to carefully plan for 'spontaneity'. This proposal can be interpreted as the disavowal of the dictatorship of taste, but also as its development into a more sophisticated form.

Glazychev's article quickly garnered criticism from Ladur in another editorial. From his more authoritative position as the journal editor, Ladur claimed that bringing DIY activities to a standard flat could only 'slightly conceal uniformity'.<sup>32</sup> Rather than giving a ready recipe for coping with individual consumers' wishes, Ladur urged the professional community – applied artists, designers and architects – to carefully reflect on this problem. He did not speak explicitly of taste, but warned against the dictatorship of functionalism, even in its disguised form, and raised the problem of 'the connection of architecture and environment' that had to be solved both by architects and by inhabitants. Ladur suggested looking for 'some kind of different, not constraining standards'. Ironically adopting the term from the exact sciences, he urged designers to create

a great number of 'degrees of freedom' for a person, with trust in her, and with the confidence that she can properly deal with them and use them to express her individual rational and aesthetic preferences, probably for things that exist only for the sake of beauty, but not for making one look like one's neighbour.<sup>33</sup>

In 1966, in addition to Ladur's editorials, *Dekorativnoe Iskusstvo SSSR* introduced another platform for debate – the section 'Problems'. The first appearance of this section included a polemical article by a young architect and theorist Viacheslav Loktev, 'On Dynamic Functionalism', that explicitly connected the flexibility of the material environment with the freedom of a consumer.<sup>34</sup> Loktev argued that the functions of material

structures (from cities to consumer objects) change much faster than their forms in the contemporary world, and that the latter hinder the development of these very functions. The result is disintegration and chaos, when conservative forms are not adequate to consumers' needs. 'The dynamism of needs is not satisfied, because the mechanism of the interconnection of the factors that define the direction in which the population's taste, interests and needs develop is not studied.'<sup>35</sup> Designers, Loktev complained, work on discrete objects, disregarding systems, and are not interested in consumer feedback. As a result of such 'blind designing', most of the produced commodities remained unsold. Loktev believed that random commodities do not guarantee flexible use and thus deny a consumer's creativity and self-expression; moreover, such objects 'deform the developing needs'. As a solution to this problem, Loktev suggested elaborating 'flexible spacious structures and ensembles of objects' and controlling them through cybernetic models. He claimed that the precise mathematical calculation of the interaction of elements within a system as well as the system's interaction with other systems would allow the management of their development, thus preventing the chaos of forms and, in addition, stimulating 'a consumer's maximal creative participation in forming his own objective-spatial environment'.<sup>36</sup> Today's designers and applied artists 'arrogantly impose ... standard level tastes and a single manner of living on the endless diversity of people's characters'. Control over flexible systems, which Loktev called the 'method of dynamic functionalism', on the contrary, presupposes consumers' active participation in correcting object systems. Simultaneously, Loktev adds, 'by modelling dynamic systems, we can manage consumers' initiative'.<sup>37</sup> This is the credo of a 'taste expert' adjusted to the age of cybernetics: the consumer is given freedom of taste, but this freedom is to be managed by the designer.

Thus, in Soviet design theory of the mid-1960s, not only was the household object made dynamic, as Boris Arvatov had said it should be in 1925, but the concept of consumer taste became more dynamic, too. While design professionals, continuing Khrushchev's policy, saw themselves as responsible for guiding consumer behaviour, this guidance became more flexible.<sup>38</sup> As Glazychev summarised in 1968, the 'journal managed to get rid of the illusory simplicity of convenient schemes, underwent the difficult break with habitual notions and proceeded to new pursuits'.<sup>39</sup>

This 'difficult break' was not purely a matter of Soviet political and economic circumstances. It was also a response to the global crisis of modernist aesthetics in the mid-1960s and design professionals' fascination with 'complexity and contradiction' (to quote the title of Robert Venturi's seminal 1966 book, which was most likely known in design circles in the USSR),<sup>40</sup> that would culminate in postmodernist architecture and design. Another important catalyst for change was the recent emergence of Soviet

semiotics and its growing influence on designers, who were receptive to the idea that objects have communicative functions and 'speak' with consumers in a specific language.<sup>41</sup>

Consequently, the role of tastemaker and organiser of the socialist material environment became more challenging. While obviously adjusting to the new economic policies of the state, applied artists pursued their professional aim of giving more nuance to their professional credos and granting more importance to artistic intuition and spontaneous creativity. One manifestation of the latter position was the Central Educational and Experimental Studio of the Artists' Union of the USSR, established in 1964, which emphasised the artistic rather than the engineering component of design.<sup>42</sup> Decorative artists working in the traditional spheres of textiles, metalwork, ceramics and glass proposed yet another manifestation.

### Questioning the criteria of applied/decorative art

From the mid-1950s, decorative artists' efforts to comply with the parameters of mass production became subject to criticism. In the *Dekorativnoe Iskusstvo SSSR* editorial from March 1965, Ladur censured the many imageless forms that did not reflect artists' individual thinking. The largest share of blame, he argued, belonged to the stubborn members of artistic councils who prevented original, creative works from entering exhibitions and eventually reaching the production line. However, he also referred to artists' own responsibilities: 'The artist's true and legitimate right, or, if you wish, duty, is to select the most meaningful from the sea of phenomena, without being false either to himself or to his friend, the viewer.'<sup>43</sup> This reconceptualisation of the professional duty of the artist, published in such an authoritative journal, reads like a radicalisation of the notion of 'honesty': not only true to materials, but also the honest expression of one's own artistic visions. Yet it also restated the dilemma that was first voiced by Smirnov and Saltykov in the early 1950s: unique artistic imagery vs. mass production (or, to use Walter Benjamin's famous formulation, 'The work of art in the age of mechanical reproduction').

Ladur's argument was a symptom of design professionals' uncertainty during the time of the growing authority of VNIITE-affiliated designers and their influence on the public discourse on material culture. In the mid-1960s decorative artists faced a number of burning questions. Do decorative artists have to subordinate their creative impulses to the requirements of mass production and mass housing? Or could they delegate these concerns to industrial designers and 'strive forward' to experiment with craft-based imagery? Would they then still be useful for Soviet society? Could they compete with industrial designers for the status of taste arbiters? Or could they answer people's spiritual needs, not calculable by statistical methods? To rephrase the question that the constructivist Vladimir

Khrakovskii had raised in 1921, how could a Soviet decorative artist of the post-Khrushchev era justify his or her existence?

One possible response was to treat work on unique objects as 'laboratory work' for updating the guidelines for designing mass-produced goods. This approach legitimised artists' work that employed forms and techniques not easily adaptable to mass production. While the reviews of decorative art expositions of the late 1950s and early 1960s, in particular 'Art into Life', are full of complaints regarding the exhibits' limited reproducibility, from 1965 *Dekorativnoe Iskusstvo SSSR* argued that singular or small-edition pieces also play an important social role due to their conceptual value. 'After appearing in a unique artwork, an idea often gets processed, adjusted to the conditions of industrial production and takes on new life in mass production. Notably, many among our artists work both in the sphere of unique works and directly for the artistic industry', explained critic Nonna Stepanian in her review of the exhibition 'Soviet Russia', held in Moscow in spring 1965.<sup>44</sup> She illustrated her thesis by reviewing three works of the Moscow ceramic artist Vladimir Olshevskii (who worked in Leningrad until 1962). His large decorative vase, made of chamotte, according to Stepanian, finely expressed gravity (due to the increased volume at the bottom) and made an impression of a natural form, thus perfectly suiting its function as an element of a park environment. The handmade geometric relief added the perception of integrity and 'architectural character'. The method of slightly increasing weight towards the bottom was used in a faience tea set with modest detailing on the handles and spouts; the handmade underglaze painting combined with relief echoed the decoration of the chamotte vase and 'underlined the basic volume of the objects'. Finally, Olshevskii's design found its way into people's homes in a porcelain tea set mass-produced at the Dmitrovskii porcelain factory. Here, easy reproducibility and 'machine clarity', accentuated by a mechanised geometric decoration, compensated for the loss of the 'feeling of the natural life of the material'. Stepanian noticed a similar skill in adopting artistic ideas to mass production in the work of many of the exhibition's participants, especially the artists of the Leningrad Porcelain Factory. The article concluded that the interrelation between unique works and the artistic industry, whatever form it might take, always essentially reflects 'the dialogue between the human being and the machine'.

The 'Soviet Russia' exhibition signalled the growing emphasis on experimentation in decorative art. Since this new tendency was not given a single clear name at the time, I use the one adopted by the prominent art critic and advocate of modernism Iurii Gerchuk: 'neodecorativism'. While Gerchuk's use of the term was critical (he worried about the artists' neglect of mass production), I believe that it aptly captures the urge to redefine the decorative and its relation to the utilitarian. Neodecorativism affected artists working in different media – ceramics, textiles, wood,

metal, glass, leather – though rarely plastic. Moreover, these artists strove to move beyond one particular material. Neodecorativism was also stimulated by the reinvigorated interest in folk art (this time far beyond the USSR borders, in tune with new Soviet internationalism), not only as a model of good socialist taste but also a source of diverse artistic motifs and techniques.

Creative reinterpretations of folk art, often in a playful, theatrical manner, were especially common among decorative artists in the Baltic and Caucasian Soviet republics, whose example was perceived enthusiastically by their colleagues in Soviet Russia. Rather than the simple modernist forms and modest geometric or stylised figurative decoration that prevailed in the early 1960s, what interested artists now were traditional forms and ornaments of Russian household objects such as a *kvassnik* (a pot for kvass – a traditional Baltic and Slavic lightly alcoholic fermented beverage). Some critics welcomed this enthusiasm for all things ‘primordially Russian’. For example, the art critic Irina Uvarova (who would become the second wife of the dissident writer Iulii Daniel) noticed a certain ‘Russian longing’ that suddenly overwhelmed intellectuals and writers in urban centres in Soviet Russia and incited their pilgrimage to old villages and ancient churches to ‘get as many largely useless things as possible’.<sup>45</sup> As Chernyshova supposes, such moods reflected the conservatism and anti-Western orientation of Brezhnev-era ideology and the state’s pragmatic flirting with moderate nationalists who could be ‘agents for mobilizing society at the time when Marxism-Leninism was losing its hold on the population’.<sup>46</sup> Chernyshova goes so far as to view decorative art’s embrace of tradition as an element of re-Stalinisation, explaining that ‘the positive re-evaluation of Stalin’s legacy sought not so much a return to Stalinist politics as a revival of a set of values from the Stalin era: in attitudes to family life, domesticity, the West and Russian nationalism’.<sup>47</sup>

However, the design professionals’ search for the interpretation (or even, to use the famous formulation of Eric Hobsbawm and Terence Ranger, ‘invention’)<sup>48</sup> of tradition was not just the obedient echo of the re-Stalinising state. While obviously influenced by the official discourse, which only started to turn more conservative in the late 1960s, design professionals such as Uvarova were also seeking personalised, intimate links with the past that artists could express through forms, textures and patterns, and present to viewers who had become tired of standard prefabricated environments. In addition, the embrace of the ‘primordial’ was not unanimous: for example, Gerchuk was sceptical of the proliferation of objects that imitated the ‘belongings of a medieval Russian prince [*kniiaz*]’). Being a prince, Gerchuk noted ironically, is not such a simple task, because it presupposes certain responsibilities, and the adoption of traditional forms of objects in the era of prefabricated flats and convenience foods should be undertaken with a good degree of criticism.<sup>49</sup> Other *Dekorativnoe Iskusstvo*

SSSR articles expressed interest in the tradition among artists of different Soviet republics of ‘sincere’ affirmation for cultural diversity and dialogue between people with different ethnic and cultural backgrounds.<sup>50</sup>

Although it was, in a way, a critique of Soviet art and design policy, neodecorativism developed within the official structure – experimental laboratories in factories and combines (*kombinaty*, institutions managing artists’ contracts with the state), supervised and financed by the Soviet Art Fund. Such experimental laboratories were instituted in the mid-1960s. Prior to that, artists employed in factories could use the facilities in their spare time for experimental work. However, those artists who worked under contracts supervised by the Art Fund had no access to the factories’ workshops.<sup>51</sup> Now, artists of different affiliations had better opportunities to develop new forms, textures and combinations of materials, without being constrained by contracts or thematic requirements.<sup>52</sup> The resulting works were shown at regular exhibitions – all-Union as well as regional and republican – as showcases of cutting-edge ideas to be adapted to industry or used in the design of public interiors. In the words of one artist, such exhibitions demonstrated ‘artistic capital in the sphere of decorative-applied art’.<sup>53</sup> Thus, the state, in fact, encouraged decorative artists to experiment freely – and they used the chance to challenge the canon of utility, just as they had challenged the canon of socialist realism a decade previously. This was, however, not a universal privilege: experimental laboratories were few, concentrated in big cities, and thus access to them was not easy. This was especially the case for artists not attached to particular factories but who worked on contracts through the Art Fund.<sup>54</sup> Using their limited time in the laboratories as much as they could, artists produced sophisticated, playful and sometimes paradoxical works, thus questioning accepted notions in a way that irritated some art critics and excited others.

Neodecorativism signalled the necessity for decorative artists to reconsider the criteria for proper socialist objects. Symptomatically, ‘Our Criteria’ was the title of an article by the critic K. Makarov, published in November 1967 as a reflection on the latest experiments by decorative artists. In a reversal of the 1950s portrayal of honest objects, Makarov opened his address by welcoming the change:

One of the major tendencies in the development of contemporary decorative-applied art has been the move away from narrowly understood utilitarianism and towards decorativeness and the monumentalisation of ordinary everyday form, on whose constructive basis unique decorative works are created. The latter are unique in terms of the originality of artistic solutions and the beauty of abstract form. Bottles, flasks and cups exist today not for wine, vases not for flowers, carpets not for making the living space warmer,<sup>55</sup> spinning wheels not for spinning, and chandeliers with candles not for lighting the house.<sup>56</sup>

This is also a reversal of Stepanian’s scheme: unique or small-edition objects do not act as inspiration for the mass production of commodities

but result from the synthesis of mass-produced forms and their detachment from habitual functions. As long as an artist is honest in his or her choices, the forms of objects are no longer required to ‘honestly’ express functions. For example, in spite of its functional obsolescence, a spinning wheel does not become an ethnographic item, but an ‘abstract’ decorative object, a tool of taste distinction in the modern world of prefabricated flats. Purely decorative objects were rehabilitated, and beauty was emancipated from the dictates of utility.

### A play of glass

Although neodecorativism spanned work in different materials – textiles, metal, wood, ceramics – glass was its foremost representative. As we have seen, this material had accumulated subtle critical tendencies in design since the beginning of the 1960s. Boris Smirnov became a leading figure in raising art glass to a new level of importance. Together with his Leningrad and Moscow colleagues, he became involved in mastering traditional techniques at the experimental workshop of the ceramics and sculpture factory in Lviv that opened in 1965.<sup>57</sup> The Lviv workshop became a laboratory for new forms of art glass, though it was the only one in the entire Soviet Union at that time (a similar production base was opened in Rostov-on-Don only in the 1970s).<sup>58</sup>

His ‘Tea Couple’ of colourful glass, produced by Lviv glassblowers, can be considered ‘decorative sculpture’ (plate 4). It has the form of a small teapot placed on top of a larger one – a method of making tea that VNIITE designers criticised as ‘unhygienic’ in the same year. Critic Natalia Titova praised the work for its ‘diversity and mirth of colours’,<sup>59</sup> while the author himself referred to the images of a traditional Russian tea-room, celebrated in famous late nineteenth-century plays by Aleksandr Ostrovsky and paintings by Boris Kustodiev<sup>60</sup> – that is, images of pre-revolutionary lower urban classes and merchants, whose tastes had been criticised by art reformists (including Smirnov himself) just a few years earlier. Openly declaring his intention to amaze the viewer, Smirnov referred not to superficial eye-catching decoration characteristic of the late nineteenth-century Russian commercial production of goods, but to the traditions of peasant art: ‘Amazement is the folk principle. Take everything from fairy tales to ceramics and glassware: all these aim to amaze. This is what an artist should provide ... Where amazement appears, art begins.’<sup>61</sup> As is clear from Smirnov’s later writing, these ideas were influenced by the concept of defamiliarisation, famously developed by literary theorist Viktor Shklovsky in 1916. Following Shklovsky, Smirnov saw a designer’s task as to disrupt the automatism of everyday actions by defamiliarising habitual forms and inspiring people to reflect on their daily lives, to think creatively.<sup>62</sup> Thus, Smirnov claimed that he



could not imagine a viewer who could perceive his decorative work as ‘real teapots’.<sup>63</sup>

However, when the ‘Tea Couple’ was shown at a Moscow exhibition in summer 1966, some viewers and critics saw it as a mockery of real teapots. Primarily this was due to the soldered lids. This seemingly trivial detail produced heated professional debates and can be considered an emblem of neodecorativism. The ‘Tea Couple’ was definitely a far cry from the ergonomic and highly functional teapots designed at VNIITE: it was of no practical help to a Soviet housewife, but, as Smirnov would argue, it was of importance to her critical thinking and creativity. Some criticised it as a ‘dishonest’ object and as the artist’s evasion of his duty to ‘serve the people’, but others took it as inspiration to redefine the concept of function. Among the latter was Makarov, who spoke of ‘spiritual utility’ – quite possibly under the influence of semiotics and the idea of objects as signifiers rather than just utilitarian things, promoted in design circles by the literary scholar Dmitrii Segal.<sup>64</sup> Makarov’s argument unfolded as follows: a teapot does not always have to be a device for tea drinking; it can be, like Smirnov’s, a decorative object that plays its role in the ‘aesthetic organisation of the objective-spatial environment’ and elevates people’s feelings.<sup>65</sup> Absurd objects such as Smirnov’s teapots, visible at all-Union and local exhibitions by late 1967, provided an opportunity to both artists and viewers to transcend narrow understandings of utility. Broadly conceived, utility relates to an artist’s clear sense of *what* and *for what aim* he or she is creating. Moreover, a contemporary decorative artist should reflect on *how else* his or her work can function in real life today. From this Makarov proceeded to the idea of different contexts of use. That is, a cup functions differently at a business breakfast than at a wedding ceremony; a teapot can be simply put on the table, but can also be ‘solemnly presented’. As the functions of industrial design and decorative art were being differentiated, Makarov reasoned that the latter tended to create objects for contemplation and aesthetic pleasure.

### Form follows the urge to amaze

Another work that outstandingly challenged the notion of the ‘honest’ and functional object was ‘Troika’ by the Leningrad glass artist Iurii Biakov – a vase, or glass, with no bottom, placed on its side. Made of transparent colourless glass, it was decorated with a stylised image of three harnessed horses – the traditional Russian *troika* – through sandblasting. Shown at the exhibition ‘Decorative Art of the USSR’ in Moscow in December 1968, this piece, like Smirnov’s, provoked debate. For example, it inspired the Leningrad ceramic artist Grigorii Kapelian to formulate the conceptual deconstruction of an object:



*All rights reserved and permission to use the figure must be obtained from the copyright holder.*

**3.3** Iurii Biakov, 'Troika', colourless lead glass, sandblasting, depolishing, wood, 1968.

if the glass is not for drinking, but for an exhibition, it can be without a bottom. In fact, if its original purpose is lost, why should it be a container, even if only for emptiness? It can be just a solid glass cylinder. And why necessarily a cylinder, and why necessarily of glass?<sup>66</sup>

At a time when VNIITE employees, following Western thinkers such as Reyner Banham, were discussing the prospects for a synthetic built environment, where functions were not tied to particular objects,<sup>67</sup> 'new decorativists' offered objects that were not tied to particular functions.

To be more precise, neodecorativism also had a moderate version, as exemplified by Olshevskii's work that was discussed by Stepanian. In this version, instead of blatant impracticality, artists opted for aesthetisation, or ritualisation, of practical functions. For example, tea sets made by the artists of the Leningrad Porcelain Factory, such as Eduard Krimmer, Vladimir Gorodetskii, Nina Slavina and others in the late 1960s, could be both functional goods and feasts for the eye. Praising Gorodetskii's set 'Blossoming Cobalt', critic Liudmila Kramarenko opined: 'With this set at home, you can specially invite guests for tea, as you do for listening to music or seeing a collection of paintings.' She also emphasised the 'incomparable joy' of touching a beautifully painted porcelain cup and drinking from it.<sup>68</sup> In this statement, joy or pleasure – visual and sensual – overshadowed 'taste' as the major element of socialist consumption and domestic order. However,

such pleasures would be available only on a limited scale, as the discussed objects were predominantly made by hand and could be produced only in small series – or even only as single exhibition items. However, when used in public interiors, they would aesthetically and spiritually enrich the Soviet material environment – or so design professionals believed.

The most vivid pronouncement of neodecorativism in Leningrad glass is probably Smirnov's 'Festive Table'. This was first exhibited in 1967 and is a large composition of coloured, free-blown glass, consisting of multiple objects, hardly attributable to customary categories (plate 5). The artist explained this work as an attempt to 'create in the human soul a joyful sense of a feast' and also as a set of curiosities, alluding to folklore images, such as a bear, a rooster and various demons, as well as to traditional vessels for a peasant feast.<sup>69</sup> While producing, as Irina Uvarova noted, the overall impression of a traditional trade fair,<sup>70</sup> 'Festive Table' can also be seen as a (self-)ironic commentary on the modern urbanite's fascination with tradition and penchant for spontaneous play as a retreat from order and rationalism (especially poignant given Smirnov's position as chief designer of the Leningrad State Optics Institute). Somewhat poetically, Makarov characterised this work as 'an expression of the contemporary artist's view regarding the nature of artistic glass through the prism of folk understanding of beauty'.<sup>71</sup> In relation to the reasonable question posed by the public and critics concerning the actual use of this artwork, Smirnov replied that he imagined the 'Festive Table' at an organisation such as the House of Friendship, for receptions or ceremonial dinners with foreign guests. This would be relevant, the artist argued, because 'today people not only in the USSR, but also in the whole world, demonstrate the thirst for something amazing, expressive and colourful'.<sup>72</sup> Obviously, and not by accident, Smirnov's explanation of the 'Festive Table' in the December 1969 issue of *Dekorativnoe Iskusstvo SSSR* was immediately followed by a survey of the work of the Italian designer Ettore Sottsass, famous for his provocative objects that betokened postmodern design.<sup>73</sup>

A large 1968 exhibition, 'Decorative Art of the USSR', where Biakov's 'Troika' instigated a debate, was the triumph of neodecorativism, and was attended in large numbers.<sup>74</sup> Visitors' responses were mixed: some complained about the unavailability of the exhibited commodities, some found them unsuitable for daily use; others, on the contrary, praised their colourfulness and diversity, and still others wanted more sophisticated decoration.<sup>75</sup> Approximately two-thirds of the January 1969 issue of *Dekorativnoe Iskusstvo SSSR* featured reviews of this exhibition and reflections on new directions for decorative art. Kramarenko positively admitted the arrival of 'a special genre of decorative-unique art'.<sup>76</sup> Defending the anti-utilitarianism of recent art, Makarov welcomed the 'division of labour' within Soviet aesthetics and, moreover, ascribed to decorative art a leading role in the synthesis between material objects and techni-

cal and natural environments. He argued: 'Narrowing its possibilities in producing specifically utilitarian objects, since this task has been partially transferred to [industrial] design, decorative art broadens its special rights in the synthesis, thus pressing monumental art to focus on certain urgent ideological tasks.'<sup>77</sup> The concern with a new synthesis became a publicly pronounced justification of decorative artists' existence as professionals within the Soviet field of (cultural) production.

Neodecorativism signalled design professionals' disappointment with the populist aspirations of the Khrushchev era and, evidently, their tiredness with the role of regulators of mass tastes and consumption patterns. Turning from regulation to reflection, decorative artists broadened the borders of good taste, and reconsidered the relationship between people and things in the age of people's growing dependence on machines. However, these artists also marked a new social distinction based on post-functional aesthetic – a distinction not only from their colleagues in the VNIITE system but also from mass consumers, who only had a limited chance to experience the 'spiritual usefulness' of unique conceptual objects at art exhibitions or in public buildings. One can presume that neodecorativist objects were produced more for their authors' colleagues than for 'the people'. Neodecorativism was probably more about symbolic and economic redistribution in the Soviet field of artistic production than about bringing amazement and joy to people's lives or achieving a happy synthesis of the built and natural environment.

However, the practitioners of neodecorativism hoped for an impact on the viewer/consumer. At the end of 1960, repudiating some critics' alarm about the crisis of Soviet decorative art, Smirnov maintained that true rationality is inseparable from emotional effectiveness: 'today we should not "apply" emotions to the rational; we should work in such a way that the rational becomes organically emotional. This is a human need, a human essence.'<sup>78</sup> Almost a year later, Smirnov explained in his interview with the secretary of the administration of the Artists' Union of the USSR, Leonid Karateev, that the meaning of his composition 'Man, Horse, Dog and Bird' was an invitation to contemplate the existential position of a modern human being vis-à-vis nature, expressed through the combination of transparent and ground surfaces and different shapes and volumes (plate 6). He concluded:

I offer a viewer a work of art, not a commodity, that is, I want to bring the viewer to the state of a non-consumerist attitude to it. I want to make him diverge from the perception of the form of a useful object and present it as an object of advanced emotion. I introduce this form into the circle of the values of artwork, not the values of everyday life objects.<sup>79</sup>

From this perspective, neodecorativism seems like a new, post-constructivist attempt to create an alternative to a capitalist commodity in spite of the

stubbornness of Soviet industry: an affective object, not reproducible on a mass scale, but responsive to people's longing for beauty and amazement.

## Conclusion

The avant-gardist slogan 'Art into Life', instrumentalised in Khrushchev's campaign to modernise the material environment, was reconsidered after his removal from power. However, rather than just a passive reflection of the course of the state ideology, this reconsideration demonstrated the artists' urge to diversify their creative and professional options. Rather than being the Party's tool for mitigating consumer frustration and breeding nationalist moods, as Chernyshova's analysis suggests, Soviet decorative art in the late 1960s became a forum for commentaries on the fundamental challenges of Soviet modernity. These challenges included the place of individuality in the world of uniform mass production and consumption, the fate of traditional crafts in an industrial age, the role of diverse folk motifs in Soviet cultural internationalism and the meaning of sincerity and emotional connection in a socialist society guided by Party dogmas. Working within the framework of Soviet institutions and policy guidelines, decorative artists and critics of the 1960s advocated for the personal freedom of artists and of ordinary people without explicitly resorting to the language of human rights and civil society.<sup>80</sup> Simultaneously, the resort to play and spontaneous expression as a means of handling recent social and political traumas and the current pressure of modern rationalism united Soviet decorative artists with post-war designers and architects across the globe.<sup>81</sup> Thus, neodecorativism was a response to both the Soviet and the global situation regarding art and politics.

## Notes

- 1 This standard formulation, recurrent in Soviet official documents and press of the 1960s, first appeared at the XXIst Party Congress in 1959. 'Kontrol'nye tsifry razvitiia narodnogo khoziaistva na 1959–1965 gody', in *Vneocherednoi XXI sezd kommunisticheskoi partii Sovetskogo Soiuz: 27 ianvaria-5 fevralia 1956 goda. Stenograficheskii otchet. Vol. 2* (Moscow: Gosudarstvennoe izdatelstvo politicheskoi literatury, 1959), p. 485.
- 2 TsGALI SPb, f. 78, op. 4, d. 391.
- 3 On the role of artists as experts acting on behalf of the state, see Reid, 'Khrushchev Modern'; Chernyshova, *Soviet Consumer Culture in the Brezhnev Era*, p. 46; Alekseyeva, 'Constructing Soviet Domesticity', pp. 57–8.
- 4 N. Mikhailov, 'Krasotu v zhizn', *Dekorativnoe Iskusstvo SSSR* 1 (1960), 1–3.
- 5 'Tovarishch! K veshcham primer'sia', *Dekorativnoe Iskusstvo SSSR* 1 (1960), 20.
- 6 'Nuzhen institut khudozhestvennot kul'tury', *Dekorativnoe Iskusstvo SSSR* 2 (1960), 1.
- 7 Reid, 'Khrushchev Modern', 26–7.
- 8 Chernyshova, *Soviet Consumer Culture in the Brezhnev Era*, p. 163.
- 9 *Ibid.*, 164–71.

- 10 G. N. Iakovleva, 'Sovetskaia arkhitektura 1960-kh gg. i predmetno-prostranstvennaia sreda', in Olga Kazakova (ed.), *Estetika 'Ottepeli': novoe v arkhitekture, iskusstve, kul'ture* (Moscow: ROSSPEN, 2014), pp. 338–9.
- 11 For example, Gerchuk, 'The Aesthetics of Everyday Life in the Khrushchev Thaw', 81–100; Iakovleva, 'Sovetskaia arkhitektura'.
- 12 Piletskii, 'Pribory i mebel', 24.
- 13 Iakovleva, 'Sovetskaia arkhitektura 1960-kh gg.', p. 342.
- 14 B. Smirnov, 'Khudozhestvennyi oblik veshchi i sposob ee izgotovleniia', *Dekorativnoe Iskusstvo SSSR* 1 (1958), 19.
- 15 N. Iaglova, 'Khudozhnik promyshlennosti Boris Smirnov', *Dekorativnoe Iskusstvo SSSR* 6 (1961), 11–15.
- 16 A. A. Troshin, 'Steklo v raznykh sferakh real'nosti 1950kh gg.', in Kazakova (ed.), *Estetika 'Ottepeli'*, p. 367.
- 17 TsGALI SPb, f. 266 op. 1, d. 291, l. 82.
- 18 TsGALI SPb, f. 266 op. 1, d. 291, ll. 19–20.
- 19 Iaglova, 'Khudozhnik promyshlennosti Boris Smirnov', 12.
- 20 Leonid Nevler, 'Tut vse gorazdo slozhnee', *Dekorativnoe Iskusstvo SSSR* 3 (1963), 29–32.
- 21 Bourdieu, *Distinction*, p. 172.
- 22 Nevler, 'Tut vse gorazdo slozhnee', 30.
- 23 *Ibid.*, 31.
- 24 *Ibid.*, 32.
- 25 *Ibid.*, 32.
- 26 Mikhail Ladur, 'Zametki redaktora', *Dekorativnoe Iskusstvo SSSR* 1 (1965), 1.
- 27 *Ibid.*
- 28 Mikhail Ladur, 'Zametki redaktora', *Dekorativnoe Iskusstvo SSSR* 8 (1965), 1.
- 29 Chernyshova, *Soviet Consumer Culture in the Brezhnev Era*, pp. 164–5.
- 30 Viacheslav Glazychev, 'Kak u vsekh ili ne kak u vsekh', *Dekorativnoe Iskusstvo SSSR* 5 (1966), 2–6.
- 31 *Ibid.*, 6.
- 32 Mikhail Ladur, 'Zametki redaktora', *Dekorativnoe Iskusstvo SSSR* 11 (1966), 1.
- 33 *Ibid.*
- 34 Viacheslav Loktev, 'O dinamicheskom funktsionalizme', *Dekorativnoe Iskusstvo SSSR* 1 (1966), 6–8.
- 35 *Ibid.*, 7.
- 36 *Ibid.*, 8.
- 37 *Ibid.*, 8.
- 38 Anna Alekseyeva argues against Chernyshova's assumption that Brezhnev's experts withdrew control over the domestic sphere in accordance with the state's intention to shift the responsibility for home arrangements to citizens in the light of economic failures. Alekseyeva demonstrates that, in fact, expert involvement in the home continued on the new terms. Alekseyeva, 'Constructing Soviet Domesticity', 70.
- 39 Viacheslav Glazychev, '1968 god – ot osnovaniia "Dekorativnoe Iskusstvo SSSR" odinadtsati', *Dekorativnoe Iskusstvo SSSR* 1 (1968), 21.
- 40 Robert Venturi, *Complexity and Contradiction in Architecture* (New York: Museum of Modern Art, 1966). It is safe to presume that people such as Viacheslav Glazychev, who attentively followed Western literature and had good reading skills in English, became familiar with this book soon after it was published.
- 41 Dmitrii Segal, 'Mir veshchei i semiotka', *Dekorativnoe Iskusstvo SSSR* 4 (1969), 38–41.
- 42 Tom Cubbin, 'Postmodern Propaganda? Semiotics, Environment and the Historical Turn in Soviet Design 1972–1985', *Journal of Design History* 30.1 (2017), 16–32, doi:10.1093/jdh/epw028; Cubbin, *Soviet Critical Design*.
- 43 Mikhail Ladur, 'Zametki redaktora', *Dekorativnoe Iskusstvo SSSR* 3 (1965), 1.

- 44 Nonna Stepanian, 'Unikal'nye obraztsy i khudozhestvennaia promushlennost', *Dekorativnoe Iskusstvo SSSR* 6 (1965), 2–6.
- 45 Irina Uvarova, 'Rus'-67', *Dekorativnoe Iskusstvo SSSR* 12 (1967), 1–10.
- 46 Chernyshova, *Soviet Consumer Culture in the Brezhnev Era*, pp. 173–4.
- 47 *Ibid.*, p. 182.
- 48 Eric Hobsbawm and Terence Ranger, *The Invention of Tradition* (Cambridge: Cambridge University Press, 1992).
- 49 Iu. Gerchuk, 'Buria v stakane bez dna', *Dekorativnoe Iskusstvo SSSR* 2 (1969), 45–7.
- 50 L. Kramarenko, 'Prazdnik vokrug tebia', *Dekorativnoe Iskusstvo SSSR* 12 (1969), 5; K. Makarov, 'Novye formy, novye zhanry', *Dekorativnoe Iskusstvo SSSR* 1 (1969), 27–9.
- 51 I. Nevskaiia, 'Nuzhna eksperimental'naia baza', *Dekorativnoe Iskusstvo SSSR* 3 (1962), 8.
- 52 Natalia Titova, 'Khudozhniki eksperimentiruiut', *Dekorativnoe Iskusstvo SSSR* 11 (1966), 20–2; Gusarova, 'Leningradskaia keramika', pp. 55–8.
- 53 'O krasote i pol'ze—eshche raz', *Dekorativnoe Iskusstvo SSSR* 11 (1969), 38–41.
- 54 TsGALI SPb, f. 78, op. 4. d. 408, l. 51.
- 55 Makarov refers to the widespread Soviet practice of using wall and floor carpets as both decorative elements and thermal insulation.
- 56 K. Makarov, 'Nashi kriterii', *Dekorativnoe Iskusstvo SSSR* 11 (1967), 11.
- 57 Titova, 'Khudozhniki eksperimentiruiut'.
- 58 Natalia Malevskaia-Malevich, conversation with the author, St Petersburg, 18 March 2014.
- 59 Titova, 'Khudozhniki eksperimentiruiut'.
- 60 L. Karateev, 'Vsesoiuznaia vystavka dekorativnogo iskusstva', *Dekorativnoe Iskusstvo SSSR* 9 (1970), 6.
- 61 Quoted in Titova, 'Khudozhniki eksperimentiruiut', 21. This idea received further development in Smirnov's 1970 book: Boris Smirnov, *Khudozhnik o prirode veshchei* (Leningrad: Khudozhnik RSFSR, 1970).
- 62 Smirnov, *Khudozhnik o prirode veshchei*.
- 63 Karateev, 'Vsesoiuznaia vystavka dekorativnogo iskusstva', 6.
- 64 Segal, 'Mir veshchei i semiotka', 40.
- 65 Makarov, 'Nashi kriterii', 11.
- 66 G. Kapelian, 'O krasote i pol'ze – eshche raz', *Dekorativnoe Iskusstvo SSSR* 6 (1968), 2.
- 67 Loktev, 'O dinamicheskom funktsionalizme'; Karl Kantor, *Krasota i pol'za* (Moscow: Iskusstvo, 1967). For a detailed discussion of this research at VNIITE, see Cubbin, 'The Domestic Information Machine'.
- 68 L. Kramarenko, 'Prazdnik vokrug tebia', *Dekorativnoe Iskusstvo SSSR* 12 (1969), 5.
- 69 Boris Smirnov, 'Krizis? Chego?', *Dekorativnoe Iskusstvo SSSR* 12 (1969), 27–9.
- 70 Uvarova, 'Rus'-67', 4.
- 71 Makarov, 'Nashi kriterii', 12.
- 72 Smirnov, 'Krizis? Chego?', 29.
- 73 L. Zhadova, 'Ettore Sottsass', *Dekorativnoe Iskusstvo SSSR* 12 (1969), 30–3.
- 74 Kramarenko, 'Prazdnik vokrug tebia', 5.
- 75 'Govoriat zritelii', *Dekorativnoe Iskusstvo SSSR* 1 (1969), 7.
- 76 Kramarenko, 'Prazdnik vokrug tebia', 4.
- 77 K. Makarov, 'Novye formy, novye zhanry', *Dekorativnoe Iskusstvo SSSR* 1 (1969), 27–9.
- 78 Smirnov, 'Krizis? Chego?', 29.
- 79 Karateev, 'Vsesoiuznaia vystavka dekorativnogo iskusstva', 7.
- 80 However, there was evidently interaction between design reformers and human rights activists. Two cases are well known. In 1968 Boris Shragin signed petitions in defence of four Moscow intellectuals accused of anti-Soviet propaganda and

---

agitation, and thus lost his position at the Research Institute of Theory and History of Fine Arts; he then actively published in uncensored periodicals and in 1974 emigrated to the US. Irina Uvarova, though not a human rights activist herself, belonged to the circles of critically minded intellectuals sympathetic to the liberal dissident movement; in 1970, she married the dissident writer Iulii Daniel. Further research is needed on the extent and impact of such interactions.

- 81 Goldhagen and Legault, 'Introduction', pp. 11–24.



## 4

### From objects to design programmes

Just as neodecorativism was generating the idea of a spiritually useful object, its leading proponent, Boris Smirnov, published his succinct *Artist on the Nature of Things*.<sup>1</sup> Its title alludes to the first-century BCE poem *De rerum natura* by the Roman poet and philosopher Lucretius. In the book Smirnov discussed the traditions, techniques and symbolic meanings of the design of consumer objects. In essence, it was a work of professional self-reflection. Smirnov paid special attention to the emergence of a new object, which he described as

a complex creative-industrial [*tvorcheski-proizvodstvennyj*] process involving different specialists: scientists, engineers and artists. The artist's role in this process is very large. He<sup>2</sup> devises at once an object itself and the way it can be used. An artist is a director [*rezhisser*] of the object's consumption; he organises the relationship between a user and an object and, on this basis, he defines its place and specificity among other objects, its consumer qualities. An artist should be broad-minded, cultured in his approach to a consumer object, whatever the purpose of this object is, and however small and insignificant it may seem.<sup>3</sup>

Although he used the term 'artist', Smirnov was in fact describing the work of a designer. His description bears a similarity to the statement of the First Congress of ICSID, held in Stockholm in 1959, which defined an industrial designer as 'one who is qualified by training, technical knowledge, experience and visual sensibility to determine the materials, mechanisms, shape, colour, surface finishes and decoration of objects...'<sup>4</sup> Like the ICSID definition, Smirnov's passage refers to the process of defining the qualities of objects on the basis of broad knowledge.

There is, however, an important distinction between Smirnov's and the ICSID's definitions if we consider the ending of the latter: '... objects, which are reproduced in quantity by industrial processes'.<sup>5</sup> Smirnov does

not specify any such scope or mode of production. His understanding of a consumer object includes both mass-produced and unique/limited-edition artefacts, such as, for example, his 'Tea Couple'. Even though Smirnov mentions industrial production in his book, what interests him most is not mass reproducibility, but the relationships between different consumer objects and between objects and their users. While theorists of productivism presented the artist as an organiser of both production and everyday life,<sup>6</sup> Smirnov believed that the artist, though educated in technology, should delegate nuts-and-bolts questions to engineers and technicians and concentrate instead on foreseeing possible consumption scenarios. It is not by accident that he uses the term *rezhisser* – 'film or theatre director' – to describe the artist's role in improving consumer culture. His vision of the artist/designer directing consumption recalls a 1957 lecture by Aleksandr Chekalov regarding vibrancy in applied art: Chekalov argued that an applied artist must be responsible for 'the whole sphere of activity' related to an object.<sup>7</sup> However, Smirnov, who combined the skills of a glass artist and a designer of optical tools, was definitely aware of the growing tendency of Soviet industrial designers (still called 'artist-engineers', *khu-dozhniki-konstruktory*) to think in terms of equipment and environment rather than in terms of separate objects.

This tendency of Soviet industrial designers manifested in a 1970 collection of reports on VNIITE research relating to domestic objects, characteristically titled 'Artistic Engineering of Everyday Equipment'. In the opening article, designers Aleksandr Riabushin and Elena Shemshurina, together with VNIITE director Iurii Soloviev, described a modern home as 'a complex system, resulting from the labour of different specialists – architects, artists[-engineers], media and communication workers, mechanical engineers, workers of light and woodworking industries, and so on'.<sup>8</sup> Design was not only recognised as a complex activity instead of a modernised applied art, but the product of design appeared more complex than just the object itself. While neodecorativists complicated their handmade singular or small-edition objects by embedding them in a web of symbolic meanings, VNIITE designers increasingly saw objects as being elements of 'equipment' and 'furnishings'.

This new vision relied on both the legacy of productivism and the contemporary western European shift towards *metadesign* (the approach to each industrially produced object as 'a part of the same combinatorial, commutative milieu').<sup>9</sup> Soviet designers reconceptualised consumer objects as tools, or props, of everyday activities. As Tom Cubbin demonstrated in his article on the Soviet design of domestic equipment,<sup>10</sup> this conceptual move was inspired by the writings of the philosopher Karl Kantor, head of the laboratory of technical aesthetics at VNIITE. Kantor drew inspiration from a particular line of productivist thinking of the 1920s that anticipated the disappearance of singular objects and their replacement by different

kinds of integral equipment: ‘material installations’ (the concept of Boris Kushner)<sup>11</sup> or ‘unembodied energy’ (as noted by Nikolai Tarabukin).<sup>12</sup> Discussing Kushner’s concept of ‘material installation’, Kantor believed in the ‘death of an object’ in the communist future, when commodity relations would disappear altogether and people would have the possibility of satisfying their needs without using objects. Material installation, for Kantor, is a dynamic system that takes diverse forms and satisfies continuously changing needs. Kantor viewed the projects for collapsible furniture, developed by Soviet designers in the 1960s, as a step towards such ‘material installations’.<sup>13</sup> However, the final goal of Soviet designers should be the overcoming of objects – *razveshchestvlennii*, which Cubbin aptly translated as ‘de-artefactualisation’.<sup>14</sup> Shifting from objects to ‘material installations’ would eventually lead to ‘total’ design that left no room for irrational consumer desires and the fetishisation of objects. While this idea, shared by Kantor and his colleagues Riabushin, Rozenblium, the architect Viacheslav Loktev and others, seems to align with the planned economy and ideological dictates of the Party, it also incorporated elements of diversity and play due to the dynamic character of this future, de-artefactualised material culture, reminiscent of the then popular western New Left critique of design and urban planning.<sup>15</sup>

However, while VNIITE developed clever predictions regarding the future of de-artefactualisation, millions of Soviet people still needed chairs and plates, refrigerators and vacuum cleaners, radios and TV sets to ensure that their everyday lives were modern and satisfying. What practical measures could designers take to meet the needs of Soviet people whose consumer choices were growing increasingly discerning and who were hardly dreaming of a de-artefactualised brave new world?<sup>16</sup> This chapter scrutinises concrete projects for the modern Soviet home, developed at VNIITE throughout the 1970s–early 1980s. It examines the different methods that designers used to overcome the narrow focus on a singular object in order to progress towards ‘total design’.

## Ideal objects

In the 1960s VNIITE was preoccupied with developing evaluation criteria and methodologies for design processes. Household objects were the first item on the agenda: from 1965 to 1966, in cooperation with the Design Institute of Poland, VNIITE conducted research on the contemporary standards of domestic space and furnishing for different consumer groups, and on consumer requirements for different categories of goods. This research was related to the development of typologies for household objects in new, prefabricated flats that I discussed in [Chapter 2](#). Altogether, these activities were aimed at preparing a solid ground for work under contracts with industries. In 1970 VNIITE published a final

report containing detailed descriptions of typologies (*nomenklatura*) for different functional zones (kitchen, bathroom, etc.) and types of equipment (for example, storage units, radio equipment).<sup>17</sup> The report suggested that by the start of the next decade, VNIITE would finalise an optimal typology for all domestic goods, thus achieving a perfect order of things. The designers could now concentrate on prototypes for concrete household objects – the domain of VNIITE Department No. 8, ‘consumer product design’.<sup>18</sup> Three consumer objects, designed by this department at three different points in the 1970s, illustrate the evolving ideal of an object for educated and discerning Soviet consumers.

### *Vitiaz’ alarm clock, 1972*

One of the first practical designs emerged from Department No. 8 in 1972: a new alarm clock model. According to the classification of household goods in Soviet trade, all types of clocks belonged to the category of *kul’ttovary* (‘cultural goods’), together with radios, photo and movie cameras, stationery and toys.<sup>19</sup> The twin practical and symbolic functions of a clock in modern urban society had been clear to Bolshevik leaders from the start of their power and was instrumentalised by the 1920s movement for the scientific organisation of labour.<sup>20</sup> One prominent participant in this movement, journalist and critic Platon Kerzhentsev, was concerned with the lack of efficiency at work and in daily life. He described time as a commodity that foreigners learned to revere, but that Russians kept disregarding and misusing. The League of Time that he established in 1923 not only engaged in fighting lateness, needless meetings and excessive speeches, but also in the rationalisation of working, public and domestic space in order to reduce unnecessary movement.<sup>21</sup> Some League of Time members wore oversized watches as their emblem; Richard Stites comments that it was a poignant choice in a country where less than a million watches and clocks were produced in 1928. Watches as a symbol of modernity emerged in a famous 1923 poster by Rodchenko and Mayakovsky, advertising the production of a Russian-Swiss firm Moser. The poster displays a human figure combined from different-sized timepieces and declares that ‘A person must have a watch’.<sup>22</sup>

Beginning in the 1930s, when all Soviet clock workshops were consolidated into several big factories and ultimately united in a trust, timekeeping devices primarily served the needs of the railways and the Red Army; needs that became even more pressing during the Second World War. After the war, Soviet factories gradually established the mass production of watches and clocks for ordinary consumers rather than just for high-ranking military men. In 1965 the USSR produced 30 million high-quality wristwatches.<sup>23</sup> A 1967 textbook for vocational schools claimed that the USSR was second in the world after Switzerland in the production of

complex and high-quality timepieces, 'leaving West Germany, Japan, the US and England behind'.<sup>24</sup> By the early 1970s the USSR had achieved the production of over 40 million timepieces of 80 engineering types and 1,800 modifications of external form per year.<sup>25</sup>

The aesthetic turn, emerging in the mid-1950s, immediately affected the watch industry. Timepieces entered the category of 'decorative-applied art'. In 1954 the Research Institute of the Time Measurement Industry (NIICHASPROM) asked the administration of the Mukhina School to include the design of clocks and watches in the topics for diploma projects in the departments of carpentry, glassmaking, metal-work and ceramics; projects that would later be used to develop new brands.<sup>26</sup> The aesthetic turn revived the 1920s campaign to rationalise everyday life, including time measurement. Watches and clocks became essential elements of modern Soviet flats as imagined by planners, engineers and designers. The newly established design services at watch and clock factories presented 'honest objects' of strict, expressively functional form and minimal decoration. Table clocks from the early and mid-1960s typically imitated home electronics that, in turn, resembled modular furniture, while wall clocks from this period often had plastic cases with sharp, asymmetrical, geometric shapes and simple combinations of colours (mostly black and white). Apparently, modern Soviet clocks would suit one of two home arrangement principles, highlighted by the critic Piletskii in 1964. They would either integrate into a rhythmical structure of home furnishing or present a striking contrast to it.<sup>27</sup> Both principles, however, negated the predominantly decorative meaning of the clock in the home, characteristic of the late Stalin era. The designer and collector of Soviet objects Azat Romanov explains this negation through two items from his impressive collection of Soviet objects: the table clock Vesna, produced in 1963 by the Vladimir clock factory (plate 7); and the wall clock Iantar' from the same year, a product of the Orel clock factory (plate 8).

The case of the table clock Vesna in the shape of an irregular trapezium looks as if it is declaring that the philistine attitude towards clocks as lavish decoration for furniture has ended and a new time has arrived. The triangle of the wall clock Iantar' by the Orel clock factory markedly differs from old-time wooden cases; it is devoid of 'excessive' details like continuous numbering on the clock face. Twelve wire stripes and three digits are now enough to tell the time: nothing extraneous!<sup>28</sup>

Both items would ideally fit a living room, study or bedroom in a new prefabricated flat. The asymmetry of Vesna could rhyme with the irregular trapezoid shape of the radio-receiver Moskvich, also issued in 1963 by the Moscow Aerophone factory (plate 9). The triangular black case of Iantar' would be balanced by an object of applied art: for example, by a minimalist black porcelain vase produced in the early 1960s at Leningrad Porcelain

Factory after the design of Anna Leporskaia, a ‘veteran’ of the avant-garde (plate 10).

For Riabushin and his colleagues at Department No. 8 in VNIITE, dedicated to ‘ordering the everyday environment in general’,<sup>29</sup> designing clocks was an opportunity to express a rationalised daily routine. After being commissioned to design a new model of alarm clock for the Rostov clock factory, Department No. 8 chose simplification of use as the guiding design principle.<sup>30</sup> The Rostov clock factory, founded in 1955 in Rostov-on-Don in south-eastern Russia, specialised in the alarm clock brand Vitiáz’. Its 1972 contract with VNIITE required that the design correspond to the factory’s materials and technology and the guaranteed patent clearance in the US, Switzerland, Japan and Yugoslavia. The design team, including the heads of Department No. 8 Boris Neshumov, Riabushin and A. Kholodkov, assisted by engineer A. Sergeev, proposed two variations of the alarm clock’s external design:

- A a brightly coloured case of spherical shape rotatable around a vertical axis;
- B a white case of horseshoe shape.

Both models could be produced from polystyrene by an injection moulding machine or stamped from a sheet of steel and then painted; the clock face’s covering and hands would be polystyrene (transparent and black/white, respectively) with winding knobs of chromium-plated steel.

In both designs, the influence of Swiss designer Max Bill, the rector of the Ulm Institute of Design, is evident. He was a proponent of the ‘good form’ concept, a science-based, socially responsible design that informed much of the development of Soviet technical aesthetics. Bill designed a series of white table and kitchen clocks for the West German manufacturer Junghans, which became classics of mid-century design.<sup>31</sup> However, the new Vitiáz’ variants were developed not only as an adaptation of the famous Swiss designs, but also as a response to the flaws of their Soviet predecessors. Both A and B models showcased how the level of detail had been reduced to enable more immediate comprehension, crucial for a person who has only just woken up. The designs required the replacement of an alarm hand with a dial in the form of an orbit around the clock face. In model A, the alarm dial is recessed in relation to the face, while in model B the dial and the face are separated by a chromium-plated metal ring. The design team believed that this solution precluded the previous confusion that often occurred between hour and alarm hands: ‘One mainly uses an alarm clock as a regular clock, and one uses the alarm hand only when setting the alarm. When the alarm rings, this hand is obscured by the hour hand. In the new models, we stress the main function of the clock face: indication of time.’<sup>32</sup> Therefore, rather than stressing the disciplinary



*All rights reserved and permission to use the figure must be obtained from the copyright holder.*

**4.1** A. Kholodkov et al., model of alarm clock 'Vitiáz' for Rostov clock factory, variant A, 1972.

function of an alarm clock – waking a user up for a working day and thus facilitating work discipline in the spirit of the 1920s League of Time – the VNIITE team minimised this function visually and spatially. Alternatively, one can see this design as increasing the functional capacity of an object, precluding its periodical function (a morning alarm) from limiting its usefulness as an instant time-measurement device.

The new Vitiáz' also promised functional convenience: its handles for time and alarm setting were knurled knobs, while the winding knobs were trapezoid. Instead of pictograms, typical of the control panels of Soviet clocks, this model had typographic labels. This was due to a recent

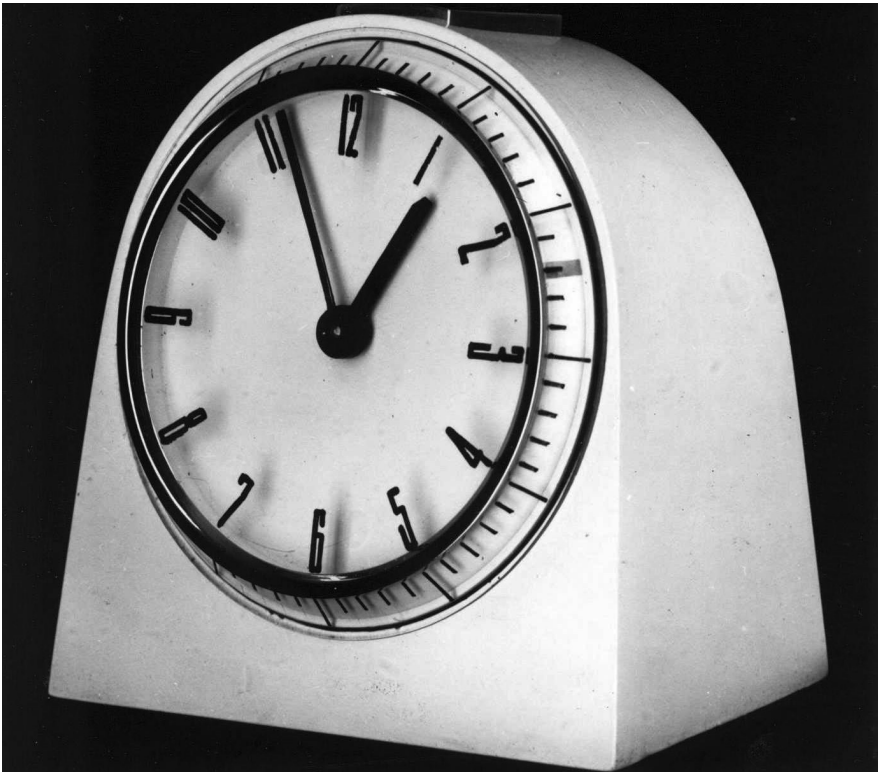

*All rights reserved and permission to use the figure must be obtained from the copyright holder.*

**4.2** A. Kholodkov et al, model of alarm clock 'Vitiaz' for Rostov clock factory, variant B, 1972.

consumer poll that showed the frequent difficulties users encountered in comprehending pictogram indicators on clocks' control panels, even after prolonged use. In model A, the control panel was protected by a dome of transparent polystyrene, whereas the horseshoe shape of the model B clock guaranteed steadiness. This aspect was crucial in the event of the user switching off the alarm while half asleep, which is often done in the dark by touch. As such, the 1972 'Vitiaz' appeared user-friendly both in terms of comprehensibility and handiness, demonstrating the important role of ergonomics in VNIITE's theoretical and practical activity.<sup>33</sup> User-friendliness was the ideal object-person relationship, which, according to the VNIITE system of quality evaluation from 1967, constituted a key part of the operational aspect of quality.<sup>34</sup> The system notably included an object-environment relationship as another component of the operational criterion. The alarm clock designers also considered this problem, at least in model A: the bright colour of the case distinguishes the clock in the interior as a mobile object, not fixed to a permanent place. As for the aesthetic aspect of quality, the designers treated the shape and physical





*All rights reserved and permission to use the figure must be obtained from the copyright holder.*

**4.3** A. Kholodkov et al., model of alarm clock Vitiaz' for Rostov clock factory, variant A, control panel, 1972.

qualities of the material as signifiers of an object's vulnerable position vis-à-vis the user: 'the round case of model A with a transparent dome over the control panel metaphorically expresses the character of the clock as a fragile and subtle mechanism.'<sup>35</sup> This appearance, the designers believed, would encourage users to handle the clock carefully. For model B, in contrast, the stable horseshoe shape made the object seem durable and steady even to not-quite-conscious users who had not fully awoken. Thus, by the means of design, Department No. 8 offered two modes of object-user interaction. In both cases, the designers downplayed the signification

of an alarm clock as a disciplining tool. Instead, a new Vitiaz' would enter a Soviet home either as a subtle reminder, through its materiality, of the fragility and thus high value of time, or as a reliable guardian of daily routine. A reading of Bill's 1956–57 kitchen clock by MoMA curator Pamela Popeson explains the aspiration of the 1972 Vitiaz' designers:

it is in charge, you just know it is. You can feel it, and not because it throws its weight around—no, not at all. It doesn't have to. It hangs up there, in its splendour, in its quiet understated elegance, ticking away, steady and sure, keeping and marking time, an ideal example of perfect form and moral purpose though design.<sup>36</sup>

### *OKA-USh refrigerator, 1973–74*

Since the unfolding of the aesthetic turn, its proponents have viewed the refrigerator as an exemplary modern object. 'Along with the excellent refrigerators and TV sets of modern forms that can beautify any flat, [our industry] forces horrible nickel-plated beds with decorative knobs and styleless ottomans into our daily life', complained the art critic Virko Blek in a 1957 article.<sup>37</sup> In the same year, *Novye Tovary* (*New Goods*), the bulletin of the All-Union Permanent Pavilion of the best models of consumer goods,<sup>38</sup> introduced two new models of domestic refrigerators, including Oka, produced by the Murom machine-building factory (the brand name comes from the river by which the city is located). The article argued that this new compressor-type refrigerator 'attracts us first of all by its beautiful internal and external finishing' and listed its conveniences, such as a capacity of 125 litres, numerous shelves (including door shelves, 'decorated with stripes of anodised aluminium') and a separate freezer of 18.5 litres. The illustration to this entry shows a housewife amazed at the view of a new fridge, proudly opened by her husband.<sup>39</sup>

Refrigerators attracted much attention from economists and art critics alike due to the centrality of the kitchen as a mid-century site of scientific modernisation.<sup>40</sup> Soviet officials' interest in modern kitchen and domestic appliances began in the mid-1950s and culminated in the famous display of the all-electric GE kitchen at the American National Exhibition in Moscow in 1959; the kitchen included a refrigerator-freezer.<sup>41</sup> Aiming to 'catch up and overtake' the US in the production of home appliances, the USSR exponentially increased the production of refrigerators over a decade: it produced approximately 529,000 in 1960 compared to a mere 1,200 in 1950, 49,200 in 1953 and 151,000 in 1955.<sup>42</sup> By 1964 this number had increased to roughly 1.7 million, and by the end of the eighth Five-Year Plan (1966–70), 4.17 million refrigerators had been produced<sup>43</sup> (though less than the planned number – 5.3–5.6 million).<sup>44</sup> Citing the data of VNIKS (Research Institute for Consumer Opinion), Natalia Chernyshova notes the growing availability of the appliance: 'A humble 17 percent could

keep their food fresh in a refrigerator in 1965, but in the early 1980s some families could even boast of having two fridges.<sup>45</sup> Chernyshova warns the reader against taking these numbers as an indication of a great Soviet lag behind the West, as American-sponsored mass consumption was a novelty in Western Europe and post-war statistics on electrical appliance ownership in the countries under the Marshall Plan were not very high either.<sup>46</sup> Refrigerators did not become indispensable in Western European kitchens until the 1960s. Even in the US, a fridge only became a home necessity rather than a luxury in 1960, as Helen Peavitt demonstrates in her recent study.<sup>47</sup>

As was typical for the Soviet consumer goods industry, the problem with refrigerator production was not so much quantity as quality. As the employees of VNIITE's department of social-economic research explained in 1965, the initial saturation of the domestic market by the increased production of household appliances, when the market 'absorbed the entire output', stimulated further production of the same models while obscuring the need for diversity. This dynamic eventually led to the production of specific models beyond demand: consumers observed many similar, low-quality goods of different brands produced by multiple factories (in the case of refrigerators, thirty-four brands were produced by twenty-six factories in 1965), but could not obtain models suitable for their specific purposes. This lack of optimal varieties of consumer goods was VNIITE's central concern from the start, as discussed in [Chapter 2](#). In the case of refrigerators, it meant the predominance of free-standing tall refrigerators ('cabinet refrigerators', in Soviet terminology) at the expense of various mini- (wall-hung, table-top and table-height) and built-in fridges. Soviet factories only produced a few models of table-height fridges. A wall-hung fridge was issued solely by the Council of People's Economy in Riga, and even that was too bulky for prefab kitchens; table-top and built-in fridges were completely absent from production. The responses to the VNIITE consumer opinion poll, published in June 1965 in the newspaper *Nedelia (Weekly)*, showed the significant demand for precisely those fridge types that the industry kept ignoring. The change in demographic trends and lifestyles increased the demand for refrigerator types that differed from the 'cabinet': for example, the decrease in the average family size, coupled with the growing public enthusiasm for hiking and automobile tourism, raised the demand for compact table-top refrigerators. While the demand for high-capacity refrigerators grew in the US and Western Europe, such models were unsuitable for the small kitchens of Soviet prefabricated flats. They also did not correspond to the modular structure that was established in the Soviet furniture industry. In addition, Soviet refrigerators had a greater weight per volume and mostly lacked temperature regulators, door-opening pedals, auto-defrost and moveable shelves. Moreover, they often had technical deficiencies.

However, as the VNIITE researchers bitterly admitted, Soviet consumers were forgiving: they simply had no choice but to buy imperfect models. Furthermore, they were barely familiar with the Western diversity of refrigerator types and thus had no opportunity to make a comparison. Lacking alternatives, individuals were happy to purchase inconvenient and oversized fridges.<sup>48</sup>

After half a decade of discussing these problems, the industry began to take steps towards improving the diversity of household appliances. For example, the Leningrad branch of VNIITE (LF VNIITE) designed a fridge bar for the Leningrad Association of Mechanical Engineering and Production of Electronic Devices (*Lenmashelektropribor*) in 1972. The artistic-technical council of LF VNIITE, which included VNIITE designers and representatives of the client, noted the high quality of the model but suggested reducing its height, including additional shelves and strengthening the stylistic unity of the external form. The initial plan for internal neon lighting had to be abandoned in favour of an incandescent lamp because of the lack of necessary equipment in production.<sup>49</sup>

A year later, Department No. 8 at the central VNIITE worked on two models of the Oka-USh electric refrigerator brand on commission from the Ordzhonikidze Machine Engineering factory in Murom.<sup>50</sup> This factory initially produced military and industrial equipment but began the production of household appliances after the Second World War. (Producing domestic goods in armaments and car factories was a common practice in the USSR, but not a uniquely Soviet one. For example, General Motors owned the famous American refrigerator-producing company Frigidaire from 1919 to 1979.)<sup>51</sup> In 1974 the designers Valerii Iabrov and Vladimir Rezvin presented the two models as part of a universal system of refrigerator types that could satisfy diverse needs. The system would be based on the combination of different-size compartments, composed of panels filled with polyurethane foam. Both models were full-height and two-compartment, accommodating 275 and 350 litres respectively. In both models, the upper compartment could work both as a freezer and a regular refrigerating unit, whereas the lower, larger compartment operated at temperatures above 0 °C and was meant only for short-term storage. The lower compartment included airtight containers for food-stuffs requiring low humidity, such as fruit, vegetables and unpackaged products, and a humidity accumulator to absorb excessive moisture. The control panel was located at the end of the fridge's top panel, above the upper compartment's door, supposedly at eye-level with the tallest family member. It included a temperature switch and thawing indicator that would signal a malfunction.

For further user-friendliness, the designers offered vertical division of both compartments into two zones: to the left, a wider zone with cantilevered moveable trays and shelves, nine altogether, and to the right,

a narrower zone with cantilever shelves for storing three-litre jars with homemade preserves and jams from the produce of ex-urban vegetable plots or countryside households, sent by relatives from the country. Such a division reflects the typical Soviet habit of using homemade preserves to compensate for food shortages (still prevalent in the 1970s beyond big urban centres). In addition, many people preferred homemade pickles or jams to those available in stores. However, as the VNIITE report observed, preserves were rarely used, mostly being consumed at special family dinners, and therefore it was logical to spatially separate them from the daily used foodstuffs. The shelves in the two zones differed in height, producing a staircase structure: the idea was presumably to avoid the impression of overcrowding and to smartly distribute the weight of the contents. Additionally, the door shelves would store cheese and butter.

In designing the external form of their refrigerator, Iabrov and Rezvin did not follow the vision of an immaculately white refrigerator as a symbol of perfect domestic hygiene, as popularised by Raymond Loewy in the 1930s.<sup>52</sup> Instead, they drew upon two recent Western trends. The first, the colour-coordinated kitchen of the 1960s, was used for a 275-litre fridge model. The second trend, the imitation of wooden furniture in kitchen equipment that was gaining prominence in the 1970s, informed the design of a 350-litre refrigerator. In the first instance, Soviet designers followed the example of the American and Western European refrigerator manufacturers who created ranges of 'fashionable colours' thanks to enamel paints by Du Pont. The VNIITE design report included a table of colours for the fridge's smooth side walls and doors. These, together with sculptured door handles, were supposed to produce a modern expressive object that would proudly replace the monotonous and clumsy Soviet fridges. In the second instance, the report carefully admitted that the model's outer appearance 'somewhat differs from a traditional, commonly accepted vision of a fridge', because its door was finished with a synthetic skin imitating the texture of wood, while its long horizontal metal handles and side walls were coated with leather-imitating synthetics.<sup>53</sup>

If the smaller Oka-USh model demonstrated a belated catching-up with Western product design in the 1960s, the larger model proudly displayed how cutting-edge Soviet kitchen technology was. In form and style, the larger model shared clear connections with American refrigerators of the same period. Peavitt summarises how opulent American fridge advertisements of the 1970s and 1980s were: 'you could buy a "sapele wood" finish Tricity or a "Copperline" Electrolux, whose "gleaming 'copper-tone' exteriors and shining trims" were "beautifully appointed" to complete the dream kitchen'.<sup>54</sup> The VNIITE report speaks of the same new, international trend: 'Recently the design of household appliances and interiors of kitchens and bathrooms has approached the decisive turn from pronouncedly



*All rights reserved and permission to use the figure must be obtained from the copyright holder.*

**4.4** Vladimir Rezvin et al., model of the refrigerator OKA-USH with a capacity of 275 litres, interior view, 1974.

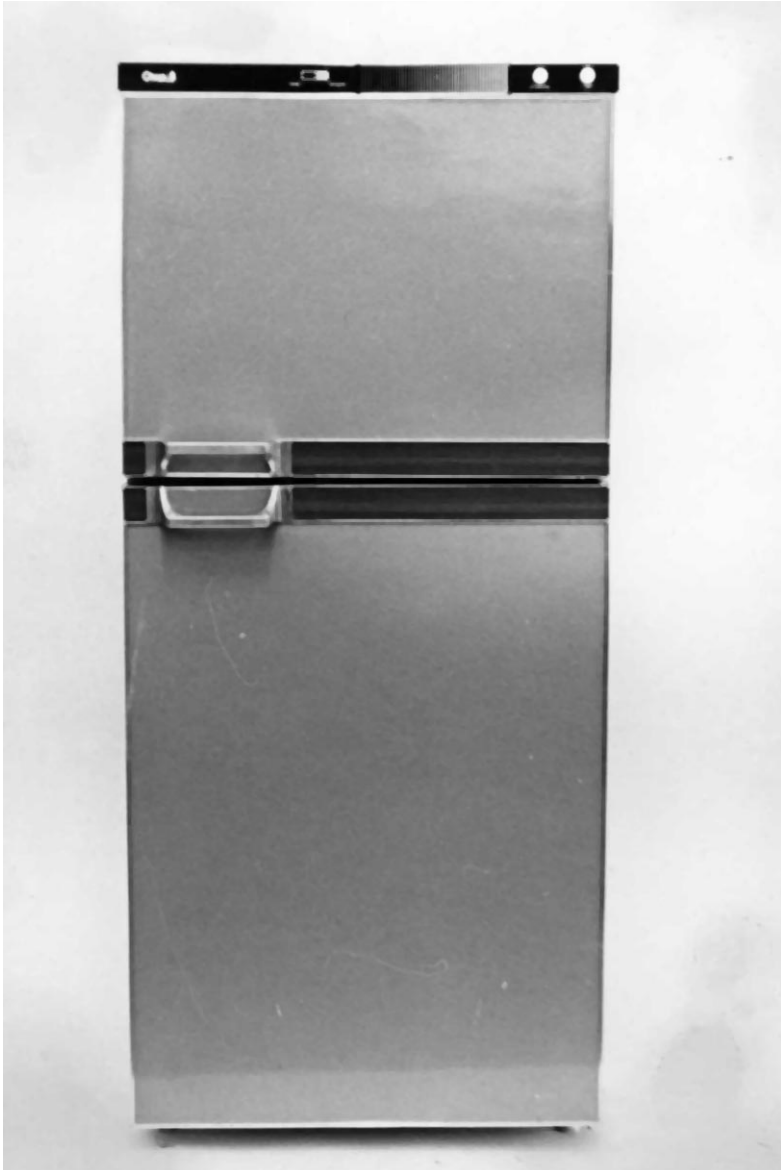

*All rights reserved and permission to use the figure must be obtained from the copyright holder.*

**4.5** Vladimir Rezin et al., model of the refrigerator OKA-USh with a capacity of 275 litres, general view, 1974.

rational, strict and technological solutions to softer, more humane ones. This has led to a widespread use (or imitation) of natural materials such as wood, leather, copper, etc.<sup>55</sup> Ten years previously, such imitation would have been an example of kitsch for the advocates of the aesthetic turn

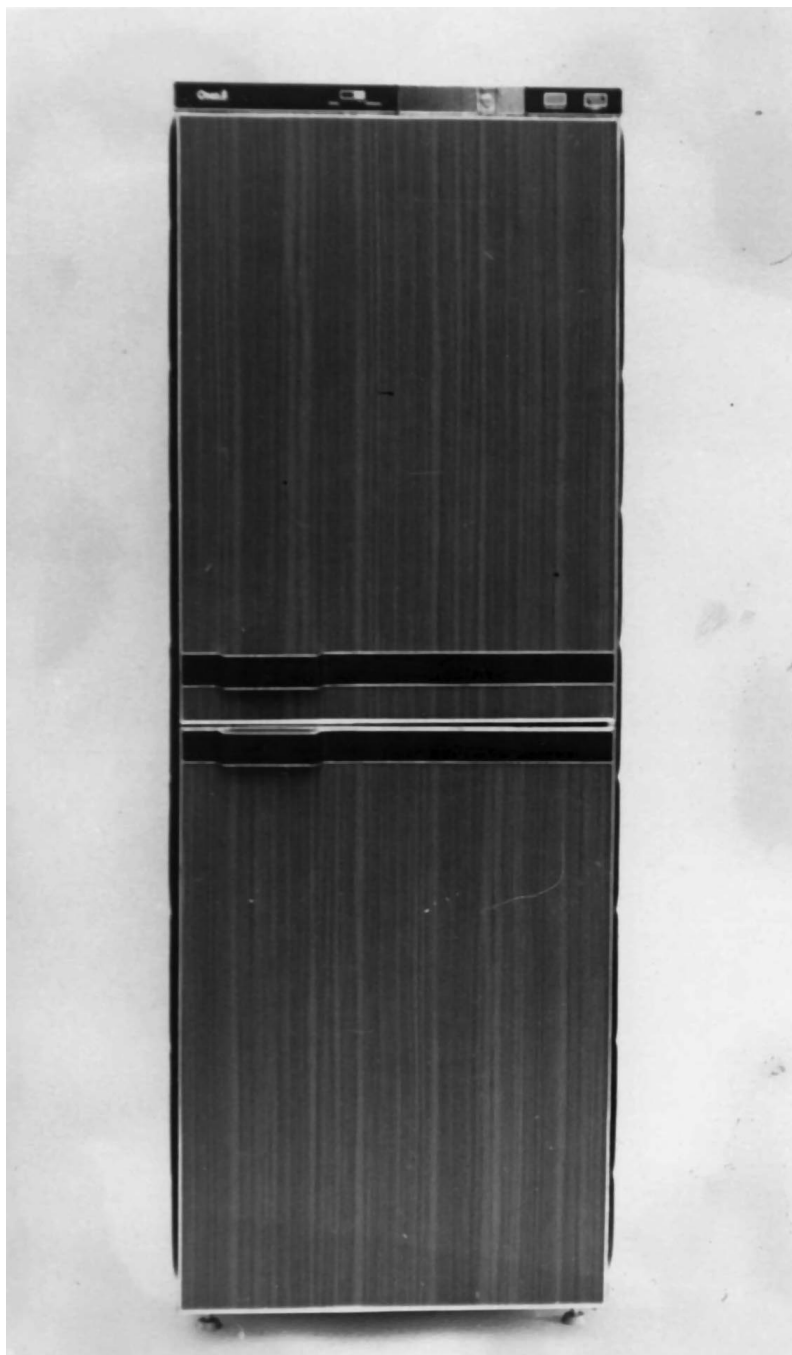

*All rights reserved and permission to use the figure must be obtained from the copyright holder.*

**4.6** Vladimir Rezvin et al., model of the refrigerator OKA-USh with a capacity of 350 litres, general view, 1974.



(recall Piletskii's 1964 article criticising electronic appliances that imitated furniture).<sup>56</sup> Soviet designers now explicitly presented the new Oka fridge as free-standing rather than built-in and 'similar to furniture in its character'.<sup>57</sup> However, if a fridge imitating an expensive cupboard would offend a Soviet modernist as a deceitful object in 1964, it appeared to be 'humane' by the 1970s – in tune not only with Western design trends, but also with the discussion of 'spiritual utility' provoked by neodecorativism in the decorative arts that was spreading to the larger community of art and design professionals.

The interior of the new Oka fridge, however, would surprise the first-time user with bright yellow and orange panels: 'such a contrasting combination of external and internal volumes produce a certain surprise effect'. The interplay between the cosy familiarity of a cupboard-like appearance and the striking brightness of its internal walls was meant to introduce diversity into the Soviet order of things. The two-version design of the Oka-USH granted consumers a choice between declining modernist aesthetics and the emergent postmodernist aesthetics, while also complicating the notion of domestic hygiene, presenting it as irreducible to the immaculate shiny surfaces. The VNIITE team strove therefore to not just catch up with Western design, but to immediately leap forward while broadening the space for diverse consumer preferences.

#### *Buran vacuum cleaner, 1977*

Even more than the brilliantly white refrigerator, the vacuum cleaner was an outspoken symbol of domestic hygiene in the mid-twentieth century. Moreover, with the post-war growth of consumer culture in the Euro-Atlantic world, it came to embody the materialist fantasies of the middle class, but also gender and class hierarchies, as epitomised in Richard Hamilton's famous collage *Just what is it that makes today's homes so different, so appealing?* (1956). Among the 'pop' household objects depicted in this artwork is a vacuum cleaner with a streamlined, rounded shape and an impressively long cable extending across the staircase ('ordinary cleaners reach only this far', says the tag on the middle stair level). This wonder of household technology defines the role and status of the (female) housekeeper, who looks, indeed, merely like the vacuum's appendage far behind the scene of the middle-class couple's obsessive and erotic personal care procedure.

Around the same time, in the late 1950s, the Soviet vacuum cleaner appeared as the rescuer of Soviet women from the burden of domestic chores that persisted forty years after the Bolsheviks' denunciation of women's ties to housework. The proponents of the aesthetic turn often referred to Lenin's 1913 anticipation that 'electric lighting and heating of every home will relieve millions of "domestic slaves" of the need to

spend three-fourths of their lives in smelly kitchens'.<sup>58</sup> Together with kitchen appliances and washing machines, a vacuum cleaner would not just ease the notorious double burden problem – the pressure to combine money-earning work with unpaid domestic labour – but also give women the time for hobbies and self-education. The introductory section of the 1965 VNIITE questionnaire about consumer preferences sadly admitted that housework occupied women's free time, leaving them with 'so many unread books, unseen theatre plays, and missed outings'.<sup>59</sup> Indeed, a Soviet woman remained not only a 'kitchen slave' to her family in 1965 – to use a popular 1920s expression – but also a slave of domestic dirt and dust. The growth in the national production of vacuum cleaners was more than twice as slow as that of refrigerators: starting at 45,500 in 1953 (compared to 49,200 refrigerators), the number of Soviet vacuum cleaners reached only 830,000 by 1965 (compared to 1,875,000 fridges).<sup>60</sup> Furthermore, this modest amount was made up of just two types: floor cleaners and hand-held upholstery cleaners. Upright cleaners, widespread in Western countries and favoured by VNIITE as the most suitable for a modern home, were completely ignored by Soviet industry.<sup>61</sup> Bulky, noisy, inefficient, lacking a typology for spare parts and a sufficient diversity of nozzles – in short, not user-friendly – Soviet vacuum cleaners perfectly illustrated the disorder of things in what was supposed to be a rational socialist consumer culture. The internal VNIITE report did not hesitate to highlight their poor design compared to Western models. For example, the Oreol cleaner, produced by the mid-1960s in the home electronics factory of the Leningrad Council of People's Economy, was considered a conglomerate of parts not just because it was visually discordant due to the different materials used, but also because it demanded different technical operations, burdening and confusing a prospective user. Moreover, it did not fit into a clear category: its weight (3.85 kg with nozzles) disqualified it as an upright, while a short hose made it a poor floor cleaner. In comparison, a light, low-noise Rapid by Siemens impressed the VNIITE designers due to its compact and visually harmonious canister made of shockproof thermoplastic and its ease of assembly.<sup>62</sup>

The 1960s fashion for Space Age forms received no better commendation than at VNIITE. From 1957, the Dnepropetrovsk Aggregate Plant (Ukraine) produced two similar vacuum cleaner models with elongated, streamlined shapes.<sup>63</sup> Both were the products of reverse engineering, widespread in Soviet factories' engineering bureaus. Raketa was based on a 1930s model by the famous Swedish manufacturer Electrolux, while Chaika closely copied a design by the Dutch firm Erres.<sup>64</sup> When modifying the Western models, the factory designers attempted to strengthen the Space Age allusions by further elongating the shapes of the cleaners and making them more 'dynamic'. The vacuum cleaner Saturn/Saturnas (with Russian and Latvian name variants), designed since 1962 at the Welding

Equipment Plant in Latvia, was a reverse-engineered 1955 Constellation model by the famous US brand Hoover.<sup>65</sup> Alluding to the recent triumph of the Soviet Union in space (Iurii Gagarin's flight took place on 12 April 1961), the designers made the form illustrate not just a planet but specifically Saturn with its rings. The 1965 VNIITE report dismisses all three models for 'unjustified striving to illustrate the cleaner's name by its appearance'.<sup>66</sup> Ironically, therefore, Soviet Space Age designs, which are often perceived today as vivid expressions of 1960s aesthetics,<sup>67</sup> were interpreted by Soviet designers as irrational and thus deficient. This contradiction neatly demonstrates the complex character of the post-Stalin aesthetic regime of arts that combined a striving for the rationalisation and ordering of things, and the search for a new imagery of socialist modernity.

The 1965 complaint about 'unjustified' vacuum cleaner forms apparently had little effect upon factory-employed designers. In 1968, for example, the Elektromashina ('electronic technology') factory in Prokopievsk (south-western Siberia) presented the Space Age variant of the Buran cleaner, with a shiny, gold canister in the form of two conjoined spheres, evoking images of Sputnik or the planets (plate 11). However, almost a decade later, in 1977, the factory recognised the need for a less imaginative but more user-friendly and original vacuum cleaner. The factory's Research Institute contracted VNIITE to design a No. 7 model of the Buran vacuum cleaner with 'advanced consumer qualities, currently lacking in domestic production'.<sup>68</sup> The VNIITE team, consisting of designers B. Korolev, E. Shtuden and G. Shmakov and the engineer V. Rozhkova, researched the current state of Soviet cleaner production and recent Western trends. They discovered that even though cleaners were produced in fourteen Soviet factories under six different ministries, this production was still far behind the West in terms of ergonomics, use of progressive materials and external appearance. Upright and portable 'backpack' models were almost non-existent: instead, low-turn engines that required larger dimensions and weight prevailed. In addition, Soviet industry had not mastered the production of paper and liquid filters, which were considered to be more advanced than those made from textiles at the time. The manufacturers produced only rotary power switches instead of the more convenient, but technically more complex, slider-type switches. This long list of the technical disadvantages of Soviet cleaners included, however, some notes on possible improvement. The Kiev Research Institute of Energy Engineering (VNIKIEMP) was elaborating a system of standard nozzle sets for domestic vacuum cleaners and planning to finish the work by 1978. Several Soviet manufacturers were also attempting to introduce models that could store the entire nozzle sets inside the canister, following the example of Hoover's C-62KC and Toshiba's VS-70EB and

SCJ-628, but had not succeeded.<sup>69</sup> VNIITE stepped in to help realise this plan.

The approach to the new Buran's external shape stemmed from the dismissal of the illustrative principle à la Raketa or Saturnas as irrational and outdated. Working in tune with the currently dominant Western approach to form-giving was essential for the VNIITE team, and their approach was functionalist – or, rather, neo-functionalist, meaning the abandonment of striking forms in favour of strict and elegant ones, usually close to a parallelepiped. Noticing another tendency originating from brands such as Toshiba and Juki in Japan of having more complicated and playful forms, the VNIITE designers nonetheless opted for a parallelepiped integrating different functional units and junctions to reduce the object's visual complexity.<sup>70</sup> Rather than masking the joint between the lower and upper parts of the canister by a strip of soft plastic, as the factory suggested, the VNIITE designers offered 'a neater solution for the form': moulding a handle (12) together with the upper canister (2) and continuing it as a relief strip around the canister.<sup>71</sup> This is an example of a structural decoration as favoured by the 1920s constructivists. Five different nozzles were stored in special sockets within a removable cassette on the top of the cleaner (9), while the bottom had clamps for fixing the hose and telescopic wand when the cleaner was stored in a vertical position. The controls – an on/off button and switch for automatic cord rewind (7) and an airflow indicator (8) were on the upper part of the canister and 'plastically processed in accordance with the general stylistic solution, informational clarity and convenience of use'.<sup>72</sup> The main objective of this design was, obviously, to achieve a harmonious integral form while also making all the different details equally comprehensible. Indeed, the initial Styrofoam model of Buran 7 looks like a sculpture, an aesthetically sound object bigger than the sum of its technical and functional parts. For a stronger effect of integrity, the designers suggested using the same material (ABS plastic) for all the details and a monochrome colour scheme: soft yellow, orange, ochre or salad green for the canister, telescopic wand and hose; beige for the nozzles.

This design was not an original VNIITE solution. As the report admits, it bore a close resemblance to the AEG 1973 model Vampyr Deluxe. Yet Buran 7 differed in a number of ways that VNIITE considered 'significant': the presence of the removable cassette for storing nozzles, the handle flexure for an easier grip, softer angles and unified colouring as opposed to the sharp red-and-white contrast of the Vampyr Deluxe. The latter, ironically, had a clear allusion to avant-garde aesthetics, whereas the VNIITE design demonstrates a softened, 'plastic' functionalism.<sup>73</sup> Buran 7 was meant to be not so much a productivist comrade and co-worker, but a modest helper, easily integrating into any home.

By the late 1970s such inconspicuous, rounded household objects had

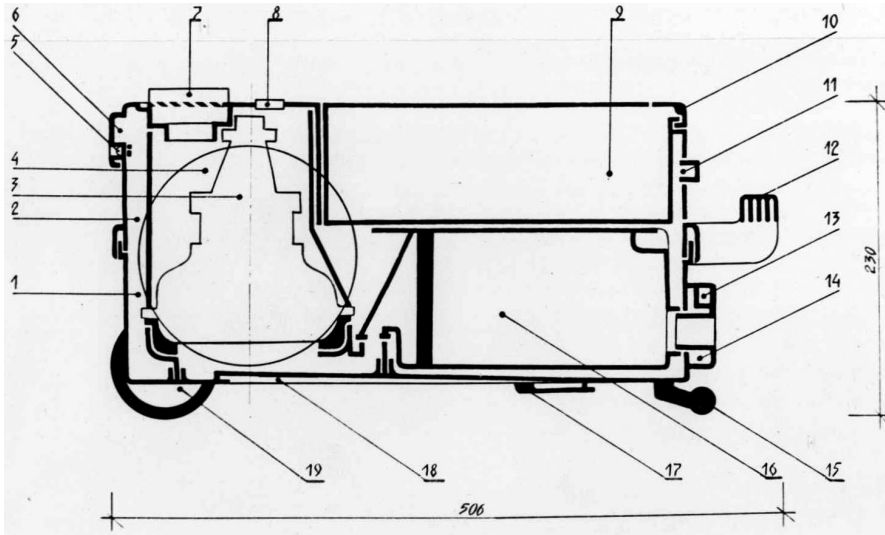

All rights reserved and permission to use the figure must be obtained from the copyright holder.

**4.7** B. Korolev et al., layout scheme of vacuum cleaner Buran 7, 1977.

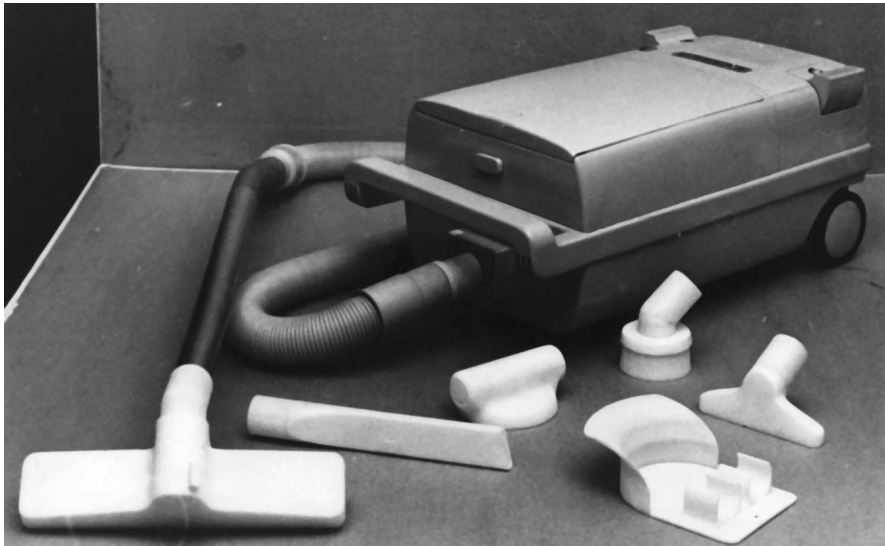

All rights reserved and permission to use the figure must be obtained from the copyright holder.

**4.8** B. Korolev et al., model of vacuum cleaner Buran 7 with a set of nozzles, 1977.

come to the forefront of design professionals' vision of proper, 'spirited' living. As art historian Liudmila Andreeva noted in *Dekorativnoe Iskusstvo SSSR* in 1975, it was 'important that objects do not displace people and that they are liveable [*uzhivchivymi*]'.<sup>74</sup> Rather than ordering things, she

proposed sharing the domestic space with them in an ethical way, whether they be household appliances or 'rehabilitated' knick-knacks. Buran 7 would nicely integrate into a home with a grandmother's cherished chairs and old photographs, and it had the appropriate nozzles for cleaning them gently.

### A home is not a house but an environment

At the same time as the Soviet government expected designers to improve the quality of consumer objects, VNIITE employees were realising that thinking in terms of separate objects was inadequate for socially responsible design. Following Tomas Maldonado, Gui Bonsiepe and Abraham Moles<sup>75</sup> of the Ulm School of Design (1953–68, the school that promoted interdisciplinary and socially responsible approaches to design), VNIITE designers tended to regard environments, rather than objects themselves, as ideal end products of their work. A team of Leningrad designers argued in 1973 that a singular object is the measure of an environment's order, and a designer's task is to define the qualities of objects, evaluate them in terms of compatibility, select compatible objects and harmonise them. The result would be an 'object ensemble' with distinct 'functional, technological and aesthetic characteristics'; subsequently, on a meta-structural level, such ensembles would be combined to constitute a diverse environment.<sup>76</sup> In such a vision, a designer obviously occupied the position of a rational observer and actor who was external to the environment in question. In a similar way, Riabushin spoke of a 'living environment' (*zhilais sreda*) as the main target of a designer's labour. The environment as an 'object-spatial unity' was presented here as a necessary framework for optimising the interrelations between planning, design and industrial production in the whole country, and thus overcoming the chaotic production of poor-quality, unwanted commodities. Riabushin characterised the environment as 'the material body [*predmetnoe telo*] of human activity' and, accordingly, argued that the designer had the power to organise the surrounding objects and materials into an integral, well-balanced environment.<sup>77</sup> This argumentation echoes the idea of an artist as an organiser of production and everyday life that was promoted in the 1920s by such avant-garde theorists as Boris Kushner, Nikolai Tarabukin and Boris Arvatov.<sup>78</sup>

However, Riabushin's vision was not rigid: it allowed room for flexibility, variation and spontaneity in designing the environment, which would counter the alienation of human beings from the world of industrially produced objects around them. Unlike his Leningrad colleagues, Riabushin took the environment as the starting point and measure for a designer, rather than the singular object: he argued that 'integral design' must precede the design of any object.<sup>79</sup>

This idea progressed over the second half of the 1970s and resulted in a more complex vision of the environment. An important role in this development belongs to the Central Educational and Experimental Studio of the Artists' Union that had been functioning since 1964 as an artistic alternative to VNIITE and its orientation to the practical tasks of the planned economy. The studio, called Senezh after the lake near Moscow next to which it was located, aimed to foster the collective, creative work of designers that its founders, philosopher Karl Kantor and designer Evgenii Rozenblium, thought of as 'the cultural self-critique of industrial design'.<sup>80</sup> For such a critique, they instrumentalised the notion of the environment. In search of an alternative to rigid city planning, Rozenblium employed a group of young architects who were knowledgeable about the latest Western critiques of modernism.<sup>81</sup> They developed the 'environmental approach' to urban planning that one of them, Andrei Bokov, later characterised as more flexible than the Soviet practice of planning and building. The environmental approach was sensitive to the dynamics of modern urban and rural life and granted equal importance to both the general and the particular. Its main method was 'cultivation' (*vzrashchivanie*), which relied on prognosis rather than a fixed plan, and therefore depended on 'comprehension and visualization of the nature of each specific site – the procedures very close to visual art'.<sup>82</sup> By 'nature', Bokov meant both the natural and the built environment, a unique combination of historical urban structures and natural areas. The environmental approach developed concurrently with the Soviet intelligentsia's interest in historical legacy and preservationist activism, which influenced the work of Senezh designers in addition to those architects who wished to make modernism more open to the diversity of human needs and natural sites.<sup>83</sup>

The conceptual move away from objects and towards environments revealed the inadequacy of the modernist vision of the order of things. As the engineer and philosopher Leonid Pereverzev, an employee at VNIITE and Senezh studio, observed in 1973,

Only recently, 10–15 years ago, many artists and designers believed that the main problem of the material world was its chaos. The path towards regulation and harmonisation seemed easy: a designer should define each thing's function and find a form adequate to this function. Impeccable in theory, in practice this path was often prohibitively simplified: function was understood in a crudely utilitarian sense, while form was seen in a mechanical-constructivist sense: a chair is a prop for sitting, a suit is a cover for thermal defence of the body, and a tea service is a system of reservoirs for storing and moving liquids. A house is a machine for living.<sup>84</sup>

If in the time of the aesthetic turn such sneering allusions to Russian Constructivism and Le Corbusier's functionalism would have placed Pereverzev in the camp of the retrogrades and Stalinists of art, the tiredness of rationalist design thinking had become common sense and *bon*

ton among art and design critics by the early 1970s. Moreover, whereas VNIITE designers continued to dismiss imaginative forms of household objects throughout the decade, as we have seen in the case of the Buran 7 design, the preference for old objects and the rise of 'artefactual conservatism [*predmetnyi konservatizm*] of grandmas and grandpas' was no longer under attack. On the contrary, these consumer choices found understanding as a legitimate reaction to 'the striving of a small group of design specialists to offer people, in a centralised manner, a ready and complete model of material environment'.<sup>85</sup> Pereverzev's text exemplifies an internal critique of VNIITE design policy and attitudes that unfolded simultaneously with the development of neodecorativism in decorative art. Both processes captured and responded to the growing popularity of antiques and rising anti-urban moods among Soviet intellectuals that were reflected in 1970s films such as *Autumn* by Andrei Smirnov (1974) or *The Theme* by Gleb Panfilov (1979).

Pereverzev argued that the repudiation of Khrushchev-era modernism was a grassroots process, initially not backed by any professional community, and labelled it 'the *anti-functionalist turn*'. Now, he continued, designers should take full responsibility for 'deforming and de-aestheticizing the artefactual world of their contemporaries', instead of pretending to be 'unrecognised geniuses' and shifting the blame entirely on to a stubborn industry. Rather than abandoning their ideas after frustrating negotiations with manufacturers, designers should open their eyes to recognising the hidden potentials of Soviet production. Electronics was especially promising in this respect, Pereverzev believed, because it had the capacity to provide immaterial yet informationally rich and dynamic objects, for example by using holography.<sup>86</sup> This rhetoric reveals Pereverzev's affinity with the critique of static materiality that had also been launched in the mid-1960s by his colleagues at VNIITE. While Karl Kantor, as mentioned earlier, anticipated the 'de-artefactualisation' of socialist daily life as the radicalisation of 1920s productivism,<sup>87</sup> architect Viacheslav Loktev, on the contrary, viewed productivism as too static to be useful for the dynamic post-war world of the late 1960s. Instead of reviving half-century-old visions, Loktev called for achieving the 'dynamic order' of things based on variation and flexibility, similarly to the environmental approach in urban planning promoted by Bokov and his colleagues.<sup>88</sup> Thus, even if the mid-1960s reaction to rigid Soviet modernism was indeed a grassroots initiative that was not directly backed by any professional instructions, as Pereverzev believed, it was a part of an important change sweeping through different social communities – from glassblowers to philosophers to the lovers of old furniture. Therefore, the anti-functionalist turn of the mid-1960s, identified by Pereverzev, can be expanded to signify this broad, multi-sited change, and to constitute a useful conceptual counterpart to the Khrushchev-era aesthetic turn.



Further into the 1970s, these revisions of functionalism and materiality informed the prognosis of the future domestic environment at VNIITE, in which Riabushin took a leading role. In 1970 Riabushin was contracted by the State Research Institute for Resistors and Capacitors to research the possible applications of automated search technology in the home. This research would result in a so-called 'Domestic Information Machine' (DIM) – a hardware system transmitting signals from the radio and television centres to individual homes. In his study of the DIM project, Tom Cubbin connects it to Riabushin's concept of domestic theatre, developed in the early 1970s – a system of packaged equipment that can be collapsed when not in use. Instead of definite objects, a domestic theatre offered mobile structures that could move on and off the 'stage' according to the consumer's changing needs.<sup>89</sup> As Cubbin explains, this vision of a post-object domestic environment was generated by Kantor's advocacy of de-artefactualisation and was also influenced by the ideas of internationally famous postmodernist design and architecture groups such as the British Archigram, the Japanese Metabolists, the Viennese Haus-Rucker-Co and Italy-based futuristic furniture designers Masanori Umeda and Joe Colombo. Riabushin's colleagues Evgenii Bogdanov and Vladimir Paperny (the future author of a seminal comparative analysis of avant-gardist and Stalinist architecture)<sup>90</sup> worked on visualising the 'domestic theatre', heavily borrowing from graphic images by the Western groups. Riabushin himself carefully praised these foreign sources as offering the solution for the flexible organisation of the home. He also quoted a famous 1965 essay by the English architectural critic Reyner Banham, 'A Home is not a House', that provocatively considered modern hardware as being sufficient to generate a domestic climate without any need for a building structure.<sup>91</sup>

This speculative prognostic work on the brave new domestic environment, conducted by Riabushin's team at VNIITE's Department No. 8, could hardly have had a substantial influence on the concrete projects commissioned by the manufacturers of urgently needed household objects. Nonetheless, in the 1970s VNIITE developed a notion of the environment that could be applied to the actual processes in Soviet industry and everyday life.

### Design programmes

By the late 1970s, VNIITE theorists had formulated a plan for 'design programmes' (*dizain-programmy*). It was based on the systemic approach to design – that is, on the vision of design as a complex system of objects, built environments, graphic elements and processes involving all these. According to the prominent VNIITE theorist Selim Khan-Magomedov, systemic design was an intellectual fashion at that time. The state's interest

in optimising the economy, which had been recentralised by Brezhnev/Kosygin's reforms beginning in 1965, concurred with the professional aspirations of VNIITE designers who were critical of a singular object approach.<sup>92</sup> Like productivist theorists of the 1920s, the designers were wary of *veshchizm* – the fetishisation of objects – and a systemic approach offered an effective antidote. Iurii Soloviev stressed the importance of design programmes not just for optimising the variety of goods, but also for inter-connecting the work of different research organisations and industries.<sup>93</sup> This type of design targeted not just the different characteristics of consumer objects, but also the processes of their production and consumption.

The first design programme was developed by VNIITE from 1973 to 1979 through a commission from the Ministry of the Instrument Industry for the All-Union Industrial Association of Electronic Measurement Instruments (*SoiuzElektroPribor*). The programme, entitled *EletkroMera* (the abbreviation for 'electronic measurement'), embraced production, logistical and material infrastructure of the whole electrical and electronic industry. It aimed at standardising the design of all electronic instruments (more than 1,500 types) and their packaging, the standardisation of workplaces and work uniforms for engineering and technical specialists, the optimisation of logistics, and the development of corporate identity. After the preliminary test, *EletkroMera* would reach a national scale: the new system of material objects, visual signs and logistics would enter thirty-two factories, each staffed by roughly 20,000 workers.<sup>94</sup> In this way, as design historian Margareta Tillberg explains, *EletkroMera* would compete with Western companies such as Siemens and General Electrics in the world market.<sup>95</sup> Even though only a small part of the programme was realised (though according to Vladimir Runge it still had a positive effect on the industry),<sup>96</sup> it demonstrates VNIITE's aim of integrating different sites of production and consumption, and managing large, complex systems. Design programmes that followed in the 1980s were dedicated to the optimisation of both consumer goods (watches, domestic audio-devices, bicycles) as well as production tools (for example, equipment for healthcare institutions).<sup>97</sup>

The design programme that most directly addressed the same problem that concerned the 'domestic theatre' proponents – namely the need to mitigate the challenges of growing international consumer culture – was born in Leningrad in 1979. The LF of VNIITE assumed the task of connecting the cultures of production and consumption through the notion of recycling. Before analysing this programme in detail, an overview of the sustainability problem in the USSR is in order.

### Waste into profit

While there is no question that late Soviet industrial projects were hazardous for the environment, one should be cautious about presuming

that all social practices under state socialism were outright unsustainable. The image of state socialism as wasteful – not only literally but also symbolically – owes a lot to the Western narrative that emerged soon after the formation of the Soviet bloc and that matured around the time of its collapse. After her emigration from Hungary to the US, sociologist Zsuzsa Gille noticed the persistence of the metaphor of waste in representations of the socialist economic and political order. Gille reminisces: ‘Visual representations of state socialism invoked the image of the state socialist landscape most familiar in the West – a grey still life composed of shoddy goods; people wearing poor, idiosyncratic clothes surrounded by houses that looked like they could fall apart at any time; and piled-up garbage.’<sup>98</sup> As she adds, Western scholars of the late 1980s and early 1990s explained the wastefulness of state socialism through the drawback of the Marxist labour theory of value that viewed natural resources as free and inexhaustible. These Western arguments and representations, however plausible, did not match Gille’s memories of her youth in socialist Hungary, such as collecting paper waste and metal scrap in competition among schoolchildren, queuing in a shop to return empty glass bottles and get a deposit, using your own bags when shopping, or coping with electricity-saving campaigns or scarcities of consumer goods.<sup>99</sup>

Similar memories often emerged in my personal conversations with people who had grown up in the USSR, which suggests that thrift marked the socialist regimes as much as wastefulness. Recent historical and sociological studies have demonstrated that reuse, recycling and saving were common practices in socialist societies, both in industry and in the consumer sphere.<sup>100</sup> Sociologists Ekaterina Gerasimova and Sofia Chuikina characterised Soviet society as a ‘repair society’, where objects had prolonged lifespans. As the planned economy, unlike the market economy, was not self-regulating, it underwent ‘constant improvement, experiment, and mandatory anti-crisis campaigns implemented by the authorities, meaning that it was perpetually under repair’.<sup>101</sup> Shortages of goods, typical of the socialist economy, facilitated people’s intimate relationships with objects and reluctance to dispose of them. Repair techniques in Soviet society included ‘fixing the item, adapting it to a secondary use, using it as material from which to make something else, redefining its symbolic status, changing the context in which it is utilised, and the like’.<sup>102</sup> Building on these authors’ arguments and on interviews with the last Soviet generation, sociologist Ol’ga Gurova suggested that the idea of disposability was barely known in Soviet culture. Coping with shortages, people constantly reused objects, or remade or exchanged them with friends and relatives (particularly children’s clothes passed to younger siblings or the younger children of friends). As a result, the ‘life of objects in Soviet culture was virtually endless’.<sup>103</sup> DIY practices for prolonging this life were encouraged by the state through advice books and articles in popular journals. A

Soviet consumer object could be repaired and reused many times before ending up in a rubbish bin, and Soviet homes could display 'rugs made of old tights and scraps, sweat pants cut up into dusters, seedlings planted in cardboard milk containers, and the like'.<sup>104</sup> Thus, if the recycling of industrial waste from the 1970s was regulated by the special sectors of the State Committees for Planning and Provision (Gosplan and Gossnab),<sup>105</sup> consumers, in fact, performed their own kinds of recycling, motivated by thrift and the understanding of resourcefulness as a virtue.

Gerasimova and Chuikina compare the Soviet 'repair society' to pre-industrial societies, where owners developed intimate relationships with things and attributed numerous symbolic meanings to them, and where 'the material environment changed little over the life of one generation; things had permanence and could long outlive their makers and first owners'.<sup>106</sup> However, as recent studies of recycling demonstrate, similar relationships to things were characteristic in Western industrial societies up to and, to some extent, beyond the 1950s. Refuting the generalisation that capitalist societies are always throwaway societies, Ruth Oldenziel and Heike Weber remind us that, in fact, the recycling of waste played a great role in twentieth-century social history, both in the West and beyond. While mass consumerism started in the US in the interwar period, it did not develop until the late 1950s and 1960s in most European countries, while thrift and reuse were never abandoned entirely.<sup>107</sup> Therefore, the environmental movement of the 1970s did not mean a radical change of practices for West European consumers but a reconsideration and optimisation of habitual ones. For example, Finn Arne Jørgensen demonstrates that different forms of recycling existed in Norway throughout the twentieth century, but in the 1970s, responding to the swift rise and crisis of Western throwaway culture, the state became more involved in regulating them.<sup>108</sup> The Soviet recycling policy developed along similar lines. While the 'repair society' in the USSR thrived in the 1930s as a result of an inefficient planned economy,<sup>109</sup> the state only attempted to govern the recycling of household refuse towards the end of the 1970s – quite possibly relying on the Western experience. The Leningrad recycling project was not, therefore, a critical response to a throwaway culture – which never fully developed under the planned economy – but an answer to the state's campaign for tightening control over waste that it viewed as a resource. Acting as experts on the state's behalf, the designers participated in forming a new 'waste regime' – to use the term proposed by Gille. A 'waste regime' is a configuration of institutional activities related to waste – its production, representation and politics.<sup>110</sup> The designers were responsible for the representation part: they determined society's perception of waste not as a matter of individual domestic management, but as a site of citizenship and relationship with the state.

Even though the image of wasteful socialism is in many ways true, the Soviet authorities in fact increasingly regarded the problem of waste

as crucial throughout the 1970s. From the start of the decade, five state agencies – the State Planning Committee (Gosplan), the State Committee of the USSR for Material and Technical Supplies (Gossnab), the Central Union of Consumer Cooperatives (Tsentrsoyuz) and the ministries of the ferrous metal industry and the non-ferrous metal industry – took control of the collection, processing and delivery of waste.<sup>111</sup> In 1975 the government founded the All-Union Institute for Secondary Resources (VIVR) within Gossnab, specifically for managing these tasks.<sup>112</sup> This initiative was not completely alien to Soviet culture: the collection of consumer and industrial waste (mostly paper and metal scraps) for recycling had been practised in the USSR since even before the Second World War, with the twin economic and didactic purposes of educating citizens in contributing to the state's prosperity.<sup>113</sup> However, as Birgitte Pristed explains, environmental concerns emerged within the official agenda for recycling paper from the late 1950s.<sup>114</sup> One can suppose that a similar tendency developed with regard to other materials, such as metal and textiles.

In the 1970s industrial enterprises were obliged to take care of the recycling of the waste they produced, and the costs of recycling were included in the general plans for production costs.<sup>115</sup> However, consumer waste was more difficult to manage. As designers expressed it, 'wasteless production' was a technical matter solved within industry, whereas 'wasteless consumption' required a complex solution. In the 1970s the task of collecting recyclable waste was shared by different organisations that lacked proper coordination.<sup>116</sup> The administration of VIVR, responsible for solving this problem, believed that it should be done through design, and commissioned Leningrad VNIITE to develop a relevant design programme. A team of five designers from the sector of complex studies, led by the sector's head Dmitrii Kochugov, developed the concept of the programme within a year. In the report on the preliminary research, they stated that the proliferation of different bodies dealing with household waste was counterproductive: 'there are too many cooks in the kitchen'.<sup>117</sup> However, the designers did not attempt to develop an ultimate solution to the problem and take full control over recycling – or, as they called it, VR-activity (VR for *vtorichnye resursy*, secondary resources). Kochugov's team admitted that the radical redesign of the recycling system required a global update of administrative, technological and personnel policy, which was beyond the designers' capacity. Therefore, the Leningrad team was careful to limit the scope of the design to adjusting the everyday habits of an average Soviet citizen in relation to the state's economic and ecological concerns. This adjustment, in turn, required a system of visual and material elements.<sup>118</sup> To use Gille's terminology, instead of designing a new waste regime, Leningrad designers took on a more modest and manageable task: to provide the current waste regime with an effective material and informational infrastructure.

The Leningrad design project targeted two areas: the household as a source of waste and public services that mediated between households and the recycling industry. The household, as the designers argued, was a growing source of waste due to increasing urbanisation (while the volume of production waste was, on the contrary, decreasing due to the inclusion of recycling within specific industrial processes). Unlike industrial enterprises, the population was a disorganised, ‘inconvenient’ partner of the state in managing resources. The two main factors in this ‘inconvenience’ were the wide geographic distribution of ordinary consumers and their lack of motivation to separate and collect waste. The first problem, the design project found, could be solved by creating a flexible network of recycling services; the second by finding effective means to encourage consumers to cooperate.

In contrast to the recent sociological arguments about the virtually endless life of Soviet things,<sup>119</sup> Kochugov et al. stated that consumption ‘inevitably ends with the phase when objects lose all their value for them [the consumers] because of moral or physical deterioration’.<sup>120</sup> At this stage, things turn into waste that a consumer, naturally, tries to get rid of in the easiest way possible: throwing it all out. In the late 1970s–early 1980s technology for the industrial separation of mixed waste was still a thing of the future, so it was essential to motivate people to separate it at home. The state could do this in several ways:

- 1 ‘Citizen obligation’ (*grazhdanskaia obiazannost*). Similar to how industrial facilities already worked, citizens would be obliged to separate and collect waste according to special regulations. However, this approach ‘would contradict the basic principles of a socialist society, whose development depends on the gradual disappearance of controlling and compulsory measures of the state and on the broad cultivation of communal forms of economy, voluntary social initiatives of the masses, and democratic social forms of administering’.<sup>121</sup> Legal compulsion had led to extremes before, such as forcing schoolchildren (or in fact their parents) to collect a monthly amount of scrap paper from old school work, with punishments if they failed to do so. Considering this, the designers considered compulsion an emergency measure, to be avoided at all costs.
- 2 The opposite of ‘citizen obligation’ was the formation of ‘citizen consciousness’ – the spreading of public understanding of waste separation and collection as crucially important for the ecology and economy. The Leningrad designers outlined a social stance that environmental historian Finn Arne Jørgensen later characterised as ‘green citizenship’: active participation in society through one’s consumption habits, ‘by choice and/or design, often motivated by an awareness of the full life cycle of any consumer products purchased’.

Recycling is a prime example of such green citizenship.<sup>122</sup> While Kochugov et al. did not use this term, they believed that conscious consumption was one of the bases of a socialist society. However, they admitted that it was not sufficient to be a strong motivational force, because a full understanding of the importance of recycling required a long-term ecological education.

- 3 The third motivation type, which was already practised in the USSR, was material rewards, such as deposits for returning glass bottles to the grocery shop, cinema tickets or ice cream for schoolchildren who won metal-collecting competitions, or vouchers for collecting at least 20 kilos of scrap paper that could be exchanged for books from the special *makulatura* series.<sup>123</sup> The Leningrad design team viewed this practice not as rewarding citizens' labour, but as re-ascribing value to things that had lost their value, resulting in the 'fetishisation of waste'. In addition, such material stimulation was based on the 'temporary' flaws of the Soviet economy and the resulting shortages of goods. An offer of certain limited goods in return for waste provoked unhealthy consumerist attitudes and, moreover, stimulated corruption and the smuggling of materials out of waste-collecting organisations.<sup>124</sup>

While in a market economy green citizenship allowed for material incentives, as Jørgensen demonstrates with the example of the state-sponsored recycling infrastructure in Norway that emerged in the 1970s,<sup>125</sup> Soviet green citizenship was imagined as free from any mercantile interests. Voluntary ecological activity had to be encouraged not by coercion but by design: creating an effective material and informational infrastructure would smoothly integrate recycling into people's daily routine. The currently uninterested population would consider recycling only if it required minimal effort on their part.

The next report on the design programme presented waste separation and collection both as automated processes and as conscious contributions to the economy and to environmental protection. A combination of industrial and graphic design would produce what Jørgensen calls a 'recycling junction' – the point of interaction between consumer and recycling agencies, 'the place and time at which the consumer chooses to recycle or discard something'. The decision processes, as Jørgensen specifies, 'depend on more than individual values; they involve competing sets of knowledge and information, disposal infrastructures, availability of new resources and goods, and time commitments, among other factors'.<sup>126</sup> To be functional, the Soviet recycling junction needed to adjust to the material structure of people's daily lives and simultaneously strongly affect their visual environment.

In 1981 Kochugov's team developed the first proposal for the design

programme that now went under the name Vtormar ('Secondary material resources'). In its initial version it only targeted urban areas, but it would later be expanded, *mutatis mutandis*, to include rural areas as well. The basic method of Vtormar was so-called 'scenic modelling' – the imagining of possible ways for consumers to be involved in a recycling project. With this method, designers exercised an environmental approach to recycling: they drafted different environments where ordinary people could interact with waste through the mediation of material objects and visual signs.<sup>127</sup> The key variations of these interactions were then illustrated by sketches. This totality can be divided into two categories: material objects and informational graphics.

The material means of recycling were presented through a vast array of collection bins, containers and transportation, suitable for different environments (flats, staircases with or without garbage chutes, courtyards, streets, parks, caterers, grocery shops, motor depots, etc.) and for different types of waste (scrap paper, glass, scrap metal, plastics, textiles, car tyres and bones). Various objects and items were introduced to maximally simplify consumers' contribution to the recycling system. These ranged from paper bags delivered to every household by mail for free, to large steel containers in neighbourhood courtyards, to specially equipped trucks, even to the uniforms worn by recycling service employees and souvenirs with the Vtormar logo. When citizens were receiving paper bags, having separate collectors on staircases and in courtyards, assisted by the municipal housing services and surrounded by eye-catching logos and slogans, they could easily adopt 'green' behaviour. The Vtormar objects, manufactured from recycled materials themselves, would also demonstrate how easy recycling had become. As meta-objects, they signified the resurrection of Soviet consumer objects without fetishising them as sources of profit. In this respect, Vtormar objects embodied the avant-garde idea of things as comrades and agents of social life – in this case, the agents of a waste regime.<sup>128</sup>

The informational means of recycling also echoed the concepts and aesthetics of the Russian avant-garde. Simultaneously, they demonstrated the influence of contemporary Western graphic design – for instance, the designers chose the Helvetica typeface for the logo and corporate identity, developed in 1957 by the Swiss designer Max Miedinger.<sup>129</sup> However, the Leningraders did not just build from Western forms of corporate identity, but rather relied on the method of 'scenic' (or as they also called it 'situational') modelling. Different everyday situations mandated different degrees of public comprehension of recycling – 'VR-messages', in the terminology of Kochugov et al. An ordinary citizen at home would be exposed to VR-messages mostly through mass media, while in an airport's waiting lounge she or he might need an element of entertainment to notice the same message. Therefore, the Vtormar programme required the involvement of a diversity of information channels: not only the familiar press,



radio and TV, but also outstanding, attention-catching elements: ‘an informational game machine, an agitation bloc, or a mobile exhibition’.<sup>130</sup> This multimedia approach again echoed the agitation and propaganda practices of the 1920s, which combined different media – from newspapers and radio to multifunctional street furniture that could combine kiosks, loudspeakers and information stands, to urban festivals.<sup>131</sup> However, unlike the 1920s avant-garde experiments, the Vtormar programme did not transmit explicit political messages. Its main educational goal was to downplay the association of trash with dirtiness and present recycling as both a profitable and environmentally conscious activity. This new image of waste was encapsulated in rhyming slogans: *Otkhody v dokhody* (‘Waste into profit’) and *Vtorichnoe – znachit otlichnoe* (‘Secondary means excellent’). The slogans, in turn, would enter urban environments in the form of *supergraphics* – a system of graphic elements in an urban space, such as banners, posters, façade decorations and street furniture. However, whereas the avant-garde supergraphics presented a striking contrast to the traditional architecture of the early Soviet cities,<sup>132</sup> the Vtormar visuals would harmoniously integrate into their environments. The choice of green and blue referred unambiguously to the natural resources that recycling helps to preserve. The neutral character of the Helvetica typeface underscored the individualised styling of the Vtormar logo, which included two Russian letters ‘R’ (Cyrillic ‘P’). While the diagonals of the two R-letters instilled a sense of movement that caught the eye, it also carried a symbolic meaning. The opposition of the two identical graphic elements with two different colours signified the change of a material’s quality in the recycling process, while the repetition itself symbolised secondary use, thus illustrating the slogan ‘Waste into profit’.<sup>133</sup> The curved semi-oval outline of the R additionally alluded to the meaning of recycling as qualitative change rather than mere repetition. The Leningraders had quite possibly been inspired by the famous recycling logo from 1970 designed by American designer Gary Anderson.

As the main producer of recycling propaganda, the Kochugov team offered an interactive mobile exhibition, the main purpose of which was to stimulate ‘active perception and instant challenging of one’s preconceived notions and, eventually, generate conscious attitudes to the [recycling] problem in general and the delivery of secondary resources in particular’. The optimal form for such an exhibition would be an ‘activity book’ produced by folding screens, made from corrugated fibreboard, representing the ‘expressive world of secondary resources’. Proceeding through the four parts of the exhibition – ‘Consumption’, ‘Pollution’, ‘Vtormar services’ and ‘The results of recycling’ – a visitor would absorb the state’s economic and ecological objectives – a soft, implicit propaganda. The emotional effect of this ‘journey’ would be achieved through spatial and colour dynamics. A visitor would proceed from dark stands to a dull grey

cube, to a 'sterile white-and-green volume' and, finally, to a vivid, colour-bursting environment. This *rite de passage* of sorts would place the visitor in the position of a folk hero who successfully overcomes challenges (environmental threat and economic disaster) and ends up 'pleasantly discovering her capacity to make the right choice and joyfully realise this choice's multiple benefits'.<sup>134</sup> However, because this 'right choice' would be pre-designed, it would be anything but free. As the Vtormar project suggests, the freedom of consumer choice had to be sacrificed for the sake of environmental protection and sustainable economy.

In 1985–86 the Vtormar design programme led to a recycling experiment in Beltsy, the third largest city in the Moldovan Soviet Socialist Republic (with a population of 143,000). This city had a well-developed industry and transport infrastructure with a stable, heterogeneous population, and had supposedly already proved responsive to public service innovations. It was considered a convenient ground for testing the new recycling approach. The project was approved by VIVR, the administrations of secondary resources of the State Provision Committees of the USSR and Moldovan SSR, and the All-Union and Moldovan trusts of secondary resources management. Whereas the material rewards programme for paper recycling resulted in the delivery of a mere 25 per cent of paper scraps to collecting stations according to the report produced by VIVR (cited by the Kochugov team),<sup>135</sup> the Vtormar programme promised to raise the figures by providing the population with all the earlier mentioned conveniences for separate collection of different wastes. Post officers and volunteer schoolchildren distributed paper or plastic collectors to households; some of the collection bags doubled as calendars. Differentiated waste containers were to be permanently set up at rubbish dumps (in older districts) or periodically at entrances to staircases (in the areas with high-rise buildings), as well as at different urban junctions: in parks, at bus stops, near kiosks and in department stores. These containers' colours and logos would make them stand out from the urban landscape. Additionally, the designers believed that 'their constant presence in sight will be an additional visual reminder of the scale and significance of the experiment'.<sup>136</sup> Before integrating these everyday recycling facilities into the domestic and urban fabric, the organising institutions planned a broad advertising campaign through mass media and a city festival with the extensive use of supergraphics.<sup>137</sup> The designers also developed special equipment for collecting stations and uniforms for collecting services employees. Kochugov's team enthusiastically anticipated the results of the Beltsy experiment, where citizens would be active participants and show their pure enthusiasm for recycling, 'unspoiled' by material incentives. However, there is currently no published or archival evidence available regarding the success – or failure – of this ambitious initiative. In any case, Vtormar never became an effective, nationwide recycling programme, and

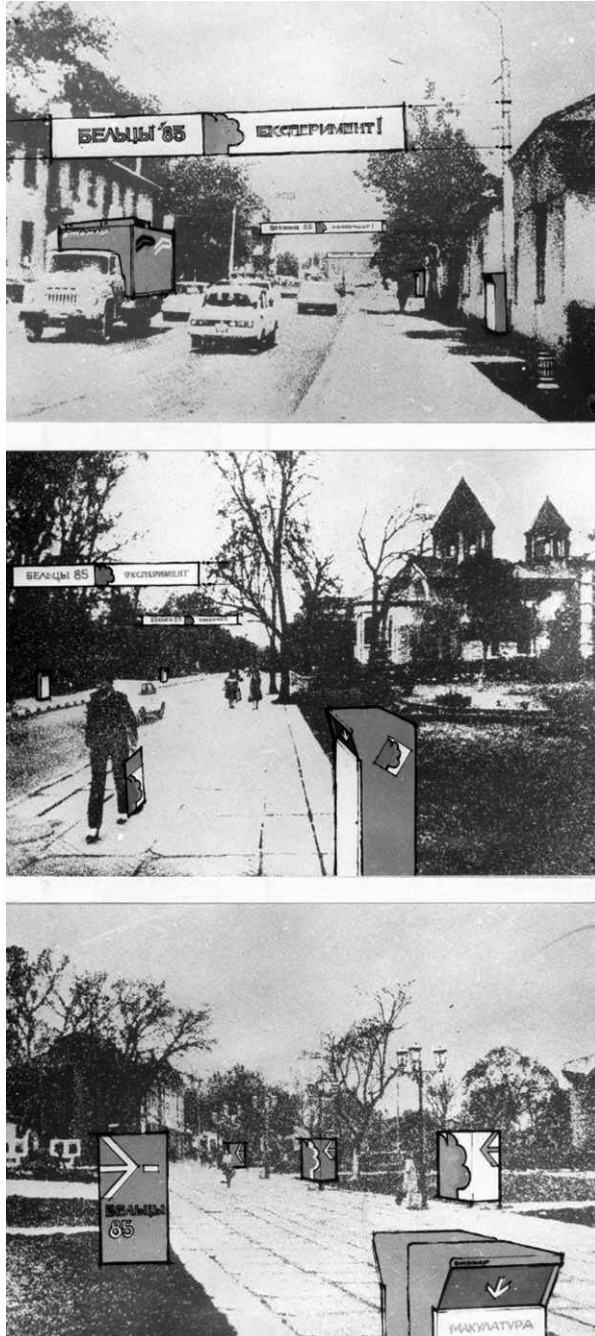

All rights reserved and permission to use the figure must be obtained from the copyright holder.

**4.9** Dmitrii Kochugov et al., design programme Vtormar ('Secondary material resources'), experimental implementation, 1984.

the approaching perestroika shifted the recycling problem to the margins of the state's agenda. Ultimately, Vtormar fell into the ranks of the many forgotten visionary projects, such as the Domestic Information Machine. That said, the idea of recycling infrastructure that was integrated yet visually striking may be of use to today's environmental activists in Russia.

## Conclusion

For Soviet design professionals, the Brezhnev era was marked by active state sponsorship for a project directed at solving the twin crisis of ineffective production and frustrated consumers. The notion of the environment, born in the late 1960s out of the crisis of functionalism (the anti-functional turn, as design theorist Leonid Pereverzev called it), became the most promising tool for improving the material culture of the present and the future. The environmental approach to design offered a solution both to the state's goal of optimising industrial production and to the designers' interest in the legacy of the Russian avant-garde and the 1970s Western socio-political critiques of design. The disenchantment with object-based functionalism had developed in parallel with the routine design of household objects. However, the latter tended to rely on rising social values such as the diversity of tastes, interest in antiques, and the search for spiritual fulfilment in the domestic environment. Furthermore, the notion of the environment was extended to signify the problematic interaction between nature and the world of commodities. As a result, the environmental threat of consumption was recognised by the state and design professionals not only as a hazard of capitalism but also as the reality of socialist societies. This new understanding of the object–environment relationship necessitated an important design task, and recycling became an important part of VNIITE's agenda. In the late 1970s the nationwide recycling system proved to be a highly relevant topic for the new format of VNIITE's work: design programmes. Combining material and visual elements, and relying on the Russian avant-garde's legacy and contemporary Western design ideas, the Leningrad design team produced an impressive programme that revealed the broad ecological implications of a socialist household. Predictably, however, this programme proved to be too ambitious for the state of the Soviet economy at a time of changing political leadership after Brezhnev's death in 1982, and was later obscured by the urgent goals of perestroika.

## Notes

- 1 Smirnov, *Khudozhnik o prirode veshchei*.
- 2 Smirnov uses the Russian male pronoun *on*, as is common in generic sentences in Russian, in the same way that masculine forms of nouns could be used as 'universal'. While the word *khudozhnik* (artist) does have a feminine form *khudozhnitsa*,

it was used only in relation to a specific female artist. Some saw (and still see) such feminine forms as pejorative, reflecting the incompleteness of Soviet gender equality. The introduction or popularisation of feminine forms for denoting professions is still a highly contested subject in Russia.

- 3 Smirnov, *Khudozhnik o prirode veshchei*, p. 129.
- 4 'Industrial Design Definition History', the official website of World Design Organisation (formerly known as International Council of Societies of Industrial Design), <http://wdo.org/about/definition/industrial-design-definition-history/> (accessed 6 June 2018).
- 5 Ibid.
- 6 Kushner, 'Organizatory proizvodstva'; Tarabukin, *Ot mol'berta k mashine*.
- 7 RGALI, f. 2943, op. 1, d. 2550, l. 10.
- 8 A. Riabushin et al., 'Tekhnicheskaiia estetika I bytovaia sreda', in Iurii Soloviev et al. (eds), *Khudozhestvennoe konstruirovaniie bytovogo oborudovaniia* (Moscow: VNIITE, 1970), p. 6.
- 9 Larry Busbea, 'Metadesign: Object and Environment in France, c. 1970', *Design Issues* 25.4 (2009), 103.
- 10 Cubbin, 'The Domestic Information Machine', 13.
- 11 Kushner presented this concept at a meeting at the Institute of Artistic Culture (Inkhuk) on 16 March 1922. The stenographic record of this presentation is in the personal archive of the architecture historian Selim Khan-Magomedov, who summarised Kushner's ideas in a chapter of his book: Khan-Magomedov, *Pionery sovetskogo dizaina*, pp. 251–2.
- 12 Tarabukin, *Ot mol'berta k mashine*, p. 30.
- 13 Kantor, *Krasota i pol'za*, pp. 255–76.
- 14 Cubbin, 'The Domestic Information Machine', 13.
- 15 Ibid., 15–19.
- 16 On consumer demand and activity, see Chernyshova, *Soviet Consumer Culture in the Brezhnev Era*, chs 3–7.
- 17 Soloviev et al. (eds), *Khudozhestvennoe konstruirovaniie bytovogo oborudovaniia*.
- 18 Azrikan, 'VNIITE'.
- 19 Central State Archive of Scientific and Technical Documentation, St Petersburg (hereafter TsGANTD SPb), f. 146, p. 2–1, d. 78, ll. 6–7.
- 20 Stites, *Revolutionary Dreams*, pp. 155–64.
- 21 Ibid., p. 156.
- 22 Marjorie L. Hilton, 'The Invention of Soviet Advertising', in Roberts (ed.), *Material Culture in Russia and the USSR*, pp. 119–34.
- 23 S. A. Selivankin and S. V. Tarasov, *Iuvelirnye izdeliia i chasy* (Moscow: Ekonomika, 1967), pp. 89–90.
- 24 Ibid., p. 90.
- 25 B. G. Radchenko, *Pokupateliu o chasakh* (Moscow: Ekonomika, 1967), pp. 16–17.
- 26 TsGALI SPb, f. 266 op. 1. d. 320, ll. 41–2.
- 27 Piletskii, 'Pribory I mebel'.
- 28 Azat Romanov and Eugenia Kikodze, text for the exhibition 'Moscow Thaw', Museum of Moscow, 16 December 2016–12 April 2017.
- 29 Riabushin et al., 'Tekhnicheskaiia estetika i bytovaia sreda', 8.
- 30 RGANTD, f. P-688, op. 4–1, d. 21.
- 31 'Kitchen Wall Clock, 1956–57', gallery label from 'Counter Space: Design and the Modern Kitchen', MoMA, 15 September 2010–14 March 2011, [www.moma.org/collection/works/139247](http://www.moma.org/collection/works/139247) (accessed 23 June 2018); Sean Lorentzen, 'The Art of Time: Max Bill and "Die gute Form"', Worn & Wound blog, 23 June 2016, <http://wornandwound.com/art-time-max-bill-die-gute-form/> (accessed 23 June 2018).
- 32 RGANTD, f. P-688, op. 4–1, d. 21, l. 5.

- 33 N. S. Gellershtein, 'Ergonomika – soizuznik khudozhnika-konstruktora', *Tekhnicheskaiia Estetika* 1 (1964), 17–18.
- 34 *Metodicheskie ukazaniia po provedeniiu ekspertizy promyshlennykh izdelii s pozitsii tekhnicheskoi estetiki* (Moscow: VNIITE, 1967), 15.
- 35 RGANTD, f. P-688, op. 4–1, d. 21, l. 5.
- 36 Pamela Popeson, 'The Perfect Kitchen Clock', *Inside/Out: A MoMA/MoMA PS1 blog*, 19 November 2010, [www.moma.org/explore/inside\\_out/2010/11/19/the-perfect-kitchen-clock/](http://www.moma.org/explore/inside_out/2010/11/19/the-perfect-kitchen-clock/) (accessed 24 June 2018).
- 37 TsGALI SPb, f. 78, op. 4, ed. khr. 517, l. 2.
- 38 The bulletin, addressed mainly to employees in industry and trade, but also to ordinary consumers, aimed to stimulate the expansion and update of goods' varieties in different regions of the USSR, and therefore emphasised new and outstanding qualities of each new commodity.
- 39 I. Gutman, 'Kholodil'nik 'Oka'', *Novye tovary* 1 (1957), n.p.
- 40 Oldenziel and Zachmann (eds), *Cold War Kitchen*; Reid, "'Our Kitchen Is Just as Good": Soviet Responses to the American National Exhibition in Moscow', in Crowley and Pavitt (eds), *Cold War Modern*, pp. 154–62.
- 41 Castillo, *Cold War on the Home Front*, pp. 130–6, 159.
- 42 *Narodnoe khoziaistvo SSSR v 1965 godu: statisticheskii ezhegodnik* (Moscow: financy I statistika, 1965), pp. 138–9; RGANTD, f. R-688, op. 1–1, d. 85, l. 3.
- 43 *Narodnoe khoziaistvo SSSR v 1965 godu: statisticheskii ezhegodnik*, p. 251.
- 44 Russian State Archive of Economy, Moscow (hereafter RGAE), f. 4372, op. 66, d. 4883, l. 22.
- 45 Central State Archive of Moscow (Tsentral'nyi gosudarstvennyi arkhiv Moskvy), f. 346, op. 1, d. 4424. Cited in Chernyshova, *Soviet Consumer Culture in the Brezhnev Era*, p. 186.
- 46 Chernyshova, *Soviet Consumer Culture in the Brezhnev Era*, p. 189. Chernyshova refers to the following study: P. Scott, 'Consumption, Consumer Credit Cards and the Diffusion of Consumer Durables', in Francesca Carnevali and Julie Marie Strange (eds), *20th Century Britain: Economic, Cultural and Social Change*, 2nd edn (London: Routledge, 2007), p. 169.
- 47 Helen Peavitt, *Refrigerator: The Story of Cool in the Kitchen* (London: Reaktion, 2017), Kindle edition, location 66.
- 48 RGANTD, f. R-688, op. 1–1, d. 57, l. 9; op. 1–1, d. 85, ll. 3–9.
- 49 TsGANTD SPb, f. 146, op. 1–4 d. 111, ll. 11–14.
- 50 RGANTD, f. R-688, op. 4–1, d. 52.
- 51 Peavitt, *Refrigerator*, Kindle location 735.
- 52 Adrian Forty, *Objects of Desire* (New York: Pantheon Books, 1986), p. 156.
- 53 RGANTD, f. R-688, op. 1–1, d. 57, l. 9; op. 1–1, d. 85, l. 7.
- 54 Peavitt, *Refrigerator*, Kindle location 959–60.
- 55 RGANTD, f. R-688, op. 1–1, d. 57, l. 9; op. 1–1, d. 85, l. 7.
- 56 Piletskii, 'Pribory i mebel'.
- 57 RGANTD, f. R-688, op. 1–1, d. 57, l. 9; op. 1–1, d. 85, l. 8.
- 58 V. I. Lenin, 'A Great Technical Achievement', in *Lenin: Collected Works*, vol. 19, trans. George Hanna (Moscow: Moscow Progress Publishers, 1977), pp. 61–2. Late 1950s references to this statement of Lenin are discussed in Reid, 'The Khrushchev Kitchen', 289–316.
- 59 RGANTD, f. R-688, op. 1–1, d. 122, l. 40.
- 60 RGANTD, f. R-688, op. 1–1 d. 85 l. 3.
- 61 RGANTD, f. R-688, op. 1–1 d. 57, l. 10.
- 62 RGANTD, f. R-688, op. 1–1 d. 57, l. 4.
- 63 'Pylesosy Raketa i Chaika', *Novye Tovary* 2 (1957), n.p.
- 64 Moscow Design Museum, *Designed in the USSR: 1950–1989* (Berlin: Phaidon, 2018), p. 192.

- 65 Ibid., p. 193.
- 66 Ibid., p. 10.
- 67 For example, the exhibition 'Moscow Thaw' at the Museum of Moscow in the winter of 2016/17 included a section 'Cosmic Theme in Soviet Design' that included a 1968 model of the vacuum cleaner Buran with a shiny surface, imitating a satellite. In his description of this section, design collector and historian Azat Romanov stressed that 'dashing contemporary forms, materials and graphic images' could be found everywhere, 'from a candy wrap or a pencil sharpener to a hydrofoil or a TV-tower'. Azat Romanov, 'Cosmic Theme in Soviet Design', wall text, *Moskovskaia Ottepel: 1953–1968*.
- 68 RGANTD, f. R-688, op. 4–1, d. 94, l. 9.
- 69 RGANTD, f. R-688, op. 4–1, d. 94, ll. 5–9.
- 70 RGANTD, f. R-688, op. 4–1, d. 94, l. 9.
- 71 RGANTD, f. R-688, op. 4–1, d. 94, l. 11.
- 72 RGANTD, f. R-688, op. 4–1, d. 94, l. 12.
- 73 RGANTD, f. R-688, op. 4–1, d. 94, l. 13.
- 74 L. Andreeva, 'Veshchi vokrug i my sami', *Dekorativnoe Iskusstvo SSSR* 7 (1975), 31.
- 75 On Western discussions of the design of environments, see Victor Margolin, 'Expanding the Boundaries of Design: The Product Environment and the New User', *Design Issues* 4.1/2 (1988), 59–64; Busbea, 'Metadesign: Object and Environment in France, c. 1970'.
- 76 TsGANTD SPb, f. 146, op. 2–1, d. 131, ll. 11–12.
- 77 Aleksandr Riabushin, 'Sreda – mera vseh veshchei', *Dekorativnoe Iskusstvo SSSR* 10 (1973), 43–6.
- 78 For example, Kushner, 'Organizatory proizvodstva'; Tarabukin, *Ot mol'berta k mashine*; Arvatov, *Iskusstvo i proizvodstvo*.
- 79 Riabushin, 'Sreda – mera vseh veshchei', 45.
- 80 RGALI, f. 82, op. 2, ed. khr. 2209, l. 50.
- 81 Cubbin, *Soviet Critical Design*.
- 82 Andrei Bokov, 'Sredovoi podkhod 10 let spustia', *Dekorativnoe Iskusstvo SSSR* 6 (1986), 7.
- 83 Bocharnikova, 'Inventing Socialist Modern', 255–7; Cubbin, *Soviet Critical Design*.
- 84 Leonid Pereverzev, 'Chelovek-veshch-chelovek', *Dekorativnoe Iskusstvo SSSR* 10 (1973), 1–2.
- 85 Ibid., 2.
- 86 Ibid., 3.
- 87 Kantor, *Krasota i pol'za*, pp. 255–76.
- 88 Loktev, 'O dinamicheskom funktsionalizme'.
- 89 Cubbin, 'The Domestic Information Machine', 13.
- 90 Paperny, *Kul'tura Dva*.
- 91 Reyner Banham, 'A Home is not a House', *Art in America* 2.4 (1965), [http://mind-control-research.net/wp-content/uploads/2016/12/4\\_banham\\_home\\_not\\_house.pdf](http://mind-control-research.net/wp-content/uploads/2016/12/4_banham_home_not_house.pdf) (accessed 10 July 2018). Tom Cubbin quotes Riabushin's book which mentioned this text: A. Riabushin, *Futurologiia zhilishcha za rubezhom* (Moscow: VNIITE, 1973), 134; Cubbin, 'The Domestic Information Machine', 19.
- 92 Mark Harrison, 'Economic Growth and Slowdown', in Edwin Bacon and Mark Sandle (eds), *Brezhnev Reconsidered* (Basingstoke: Palgrave Macmillan), pp. 52–7; Tillberg, 'Made in the USSR', 38.
- 93 Iu. B. Soloviev, 'Prolemy I perspektivy sovetskogo dizaina', *Tekhnicheskaiia Estetika* 10 (1984), 3–5.
- 94 Runge, *Istoriia dizaina, nauki i tekhniki*, pp. 263–4; West, 'CyberSovietica', pp. 179–80.
- 95 Tillberg, 'Made in the USSR', 36.

- 96 Runge, *Istoriia dizaina, nauki i tekhniki*, p. 264.
- 97 Ibid.
- 98 Zsuzsa Gille, *From the Cult of Waste to the Trash Heap of History: The Politics of Waste in Socialist and Postsocialist Hungary* (Bloomington, IN: Indiana University Press, 2007), pp. 1–2.
- 99 Ibid., p. 3.
- 100 Paul R. Josephson, *Resources Under Regimes: Technology, Environment, and the State* (Cambridge, MA: Harvard University Press, 2004), pp. 186–9; Ekaterina Gerasimova and Sof'ia Chuikina, 'The Repair Society', *Russian Studies in History* 48.1 (2009), 58–67, doi:10.2753/RSH1061-1983480104; Ol'ga Gurova, 'The Life Span of Things in Soviet Society', *Russian Social Science Review* 50.4 (2009), 49–60, doi:10.1080/10611428.2009.11065356; Milena Veenis, *Material Fantasies: Expectations of the Western Consumer World Among the East Germans* (Amsterdam: Amsterdam University Press, 2012); Jakob Calice, 'Garbage Recycling Rhetoric in the GDR: An Environmental Historic Perspective', *Trans-disciplinary Journal of Emergence* 3.2 (2005), <http://textfeld.ac.at/text/713/> (accessed 12 March 2018); Birgitte Beck Pristed, 'Reading and Recycling: Soviet Paper Debate and the Makulatura Books, 1974–1991', forthcoming in *Russian Review*.
- 101 Gerasimova and Chuikina, 'The Repair Society', 59.
- 102 Gerasimova and Chuikina, 'The Repair Society', 60.
- 103 Gurova, 'The Life Span of Things in Soviet Society', 58.
- 104 Gerasimova and Chuikina, 'The Repair Society', 68.
- 105 Viazheslav Deviatkin, 'Upravleniie otkhodami v Rossii: pora Ispol'zovat' otechestvennyi I zarubezhnyi opyt', *Otechestvennye Zapiski* 2 (2007), [www.strana-oz.ru/2007/2/upravlenie-othodami-v-rossii-pora-ispolzovat-otchestvenny-i-zarubezhny-opyt](http://www.strana-oz.ru/2007/2/upravlenie-othodami-v-rossii-pora-ispolzovat-otchestvenny-i-zarubezhny-opyt) (accessed 14 March 2018).
- 106 Gerasimova and Chuikina, 'The Repair Society', 60.
- 107 Ruth Oldenziel and Heike Weber, 'Introduction: Reconsidering Recycling', *Contemporary European History* 22.3 (2013), 349, 354, doi:10.1017/S0960777313000192.
- 108 Finn Arne Jørgensen, 'Green Citizenship at the Recycling Junction: Consumers and Infrastructures for the Recycling of Packaging in Twentieth-Century Norway', *Contemporary European History* 22.3 (2013), 499–516, doi:10.1017/S0960777313000258.
- 109 Gerasimova and Chuikina, 'The Repair Society', 64.
- 110 Gille, *From the Cult of Waste to the Trash Heap of History*, pp. 34–5.
- 111 Staly V. Dudenkov, 'The Recycling of the Wastes of Production and Consumption as an Aspect of the Environmental Protection in the USSR', in K. Kuri (ed.), *Appropriate Waste Management for Developing Countries* (New York: Plenum Press, 1985), pp. 95–100.
- 112 Deviatkin, 'Upravleniie otkhodami v Rossii'.
- 113 Pristed, 'Reading and Recycling'.
- 114 Ibid.
- 115 Deviatkin, 'Upravleniie otkhodami v Rossii'.
- 116 *Razrabotka dizain-programmemy 'Vtorichnye resursy'. Zakliuchitel'nyi otchet po teme 1969–1* (Leningrad: LF VIITE, 1980), [www.waste.ru/uploads/library/design-programmem-vr.pdf](http://www.waste.ru/uploads/library/design-programmem-vr.pdf) (accessed 12 November 2016).
- 117 Ibid., p. 5.
- 118 Ibid., pp. 5–37.
- 119 Gerasimova and Chuikina, 'The Repair Society'; Gurova, 'The Life Span of Things in Soviet Society'.
- 120 *Razrabotka dizain-programmemy 'Vtorichnye resursy'*, p. 11.
- 121 Ibid., p. 12.
- 122 Jørgensen, 'Green Citizenship at the Recycling Junction', 500.



- 123 Pristed, 'Reading and Recycling'; 'Kak sobirali vtorsyr'e v SSSR', blog of the Association of St Petersburg bloggers, 2 May 2017, <https://goodspb.livejournal.com/673912.html> (accessed 20 March 2018).
- 124 *Razrabotka dizain-programmemy 'Vtorichnye resursy'*, p. 12.
- 125 Jørgensen, 'Green Citizenship at the Recycling Junction'.
- 126 *Ibid.*, 501.
- 127 TsGANTD SPb, f. 146 op. 2–2 d. 141, ll. 5–6.
- 128 TsGANTD SPb, f. 146, op. 2–2, d. 141, 142. The rest of this section is based on these documents and the one cited in note 78.
- 129 The classic Cyrillic version of Helvetica was developed in 1981–84 by a VNIITE designer Anatolii Kudriavtsev, [www.paratype.ru/help/designers/designer.asp?code=AD\\_KDA](http://www.paratype.ru/help/designers/designer.asp?code=AD_KDA) (accessed 20 March 2018). I am thankful to Alyona Sokolnikova for bringing this to my attention.
- 130 TsGANTD SPb, f. 146 op. 2–2 d. 141, l. 17.
- 131 Khan-Magomedov, *Pionery sovetskogo dizaina*, pp. 108–34.
- 132 *Ibid.*, p. 110.
- 133 TsGANTD SPb, f. 146 op. 2–2 d. 141, l. 17.
- 134 TsGANTD SPb, f. 146, op. 2–2, d. 143, ll. 38–9.
- 135 'Eksperiment Vtormar v deistvii', *Tekhnicheskaiia Estetika* 7 (1986), 13.
- 136 *Ibid.*
- 137 TsGANTD SPb, f. 146, op. 2–2, d. 146, ll. 8–13.

## 5

### A new production culture and non-commodities

After the two turns in Soviet material and visual culture – the Khrushchev-era aesthetic turn and the mid-1960s anti-functionalist turn – Soviet material culture became a site of great plurality and diversity, otherwise rarely associated with the Brezhnev era. Whereas VNIITE theorists explored the possibilities of flexible and user-sensitive systemic designing, as the preceding chapter has discussed, the critics and practitioners of decorative art chose self-reflection as their foremost professional strategy.

This choice had two important consequences. First, decorative artists gravitated further towards more complex forms. While between the late 1950s and early 1960s applied artists expected the Artists' Union to facilitate the production of 'simple and neat objects',<sup>1</sup> and critics saw 'beauty in simplicity',<sup>2</sup> a new view was expressed beginning around 1963 that now 'everything is much more complicated'.<sup>3</sup> By the 1970s, the complexity of material objects became not only undeniable but also welcome. Evaluating the 1970 All-Union Decorative Art Exhibition in Moscow, dedicated to Lenin's 100th birthday, the editorial team of *Dekorativnoe Iskusstvo SSSR* noted the exhibition artists' skill in solving 'complex, and sometimes deliberately complicated tasks'.<sup>4</sup> If at this point 1960s neodecorativism was often still seen by critics as a creative laboratory for mass-produced objects, 1970s decorative art affirmed the social value of complex designs, hardly adoptable for mass production. Simplicity lost its status as a universal value in socialist material culture and ceased to be a necessary characteristic of a comradely object.

The increasing distance from mass production was motivated by the professional ambition to elevate decorative art to the level of philosophical exploration, to make it a forum for discussing the universal human condition like any other field of art. As in the early 1950s, artists working with ceramic, glass, textiles and other materials demanded that they be

recognised as proper artists. This time, however, their argument did not hinge on the indispensability of the objects they designed to people's daily lives, but on the rich potential of the material to express complex ideas – the artists proposed a non-utilitarian materiality. A ceramic artist could now be like a sculptor or, even better, a painter; ceramics were more powerful and eloquent than the traditional materials of fine art. This new argument echoed contemporary discussions of decorative arts and crafts in the United Kingdom. According to Judy Attfield, professional craftspeople often rebranded their work as 'applied art' or 'decorative art' in the 1970s, hoping to gain public acceptance for their work as art. 'To those critics who saw craft as a retreat from innovation, modernism and progressive design, the bid was to elevate its status by redefining craftwork as a "creative" art and "craftspeople" as designer-makers with the right of entry into the circle of respectability enjoyed by fine artists.'<sup>5</sup> Although this ambition remained unrealised, British decorative arts did achieve some prestige as a middle-class profession through the growth of degree courses on ceramics, woodwork, plastics, jewellery and metalwork. In the Soviet Union, however, the decorative artist did not want a middle-class status – officially still non-existent in Soviet society – but rather yearned to enter the intelligentsia and take part in its traditional role as an educated sub-community cultivating critical attitudes in society. While not openly criticising the Soviet system and not taking the dissident path, decorative artists in the Brezhnev era navigated the muddy waters of late socialist cultural policy in order to make a difference in Soviet aesthetics and consumer culture through their mastery of materials. They attempted to make their objects say more than the official vision of decorative art allowed. They aspired to create much more than just commodities.

This chapter examines the development of non-utilitarian objects in the changing political, economic and social climate of the Brezhnev era. It begins by examining the mass redefining of Soviet material and visual culture at a time when many once considered rigid lines blurred: between arts, between types of objects and between modes of creative work. Further, this chapter addresses a recurrent and painful problem, first clearly formulated by the Russian avant-garde: the role of the artist in industry and mass production. The first section will focus on an interview series conducted by the *Dekorativnoe Iskusstvo SSSR* team in 1973 with artists, engineers and administrators at several Soviet factories that produced household objects. Then, proceeding to the mid-1970s, this chapter will discuss design professionals' investigation of the messages that 'talkative' objects conveyed to exhibition viewers and to everyday users. Finally, the chapter will outline the case of a Leningrad group of ceramic artists, One Composition, active from 1977 to 1986, as they exemplify the major inquiries and preoccupations in decorative art of the Brezhnev era – most of all, its anti-commodity stance.

## Celebrating clashes

From the mid-1960s, the All-Union exhibitions of decorative art became forums for lively professional debates about the social/economic responsibility of artists as much as about the aesthetic criteria of art. The 1968 exhibition prompted a clash of opinions between artists and critics: while some, such as Iurii Gerchuk, sensed the imminent crisis of decorative art, others – for example, Nonna Stepanian, Liudmila Kramarenko, Kirill Makarov and Boris Smirnov – attempted to reclaim the value of decoration in post-industrial society. The professional community of decorative art specialists welcomed this clash as clearly being a positive, productive development, and *Dekorativnoe Iskusstvo SSSR* repeatedly propagated this idea. At the roundtable of the 1968 exhibition, Belarusian designer and critic Oleg Surskii refuted some of his colleagues' worries that the reconsideration of aesthetic ideals brings chaos and harm to art:

Probably, what is happening is a very deep insight into a certain new, sharper, probably more extravagant aesthetic pattern. We are learning subtleties that we have missed in a crystal-clear system [of modernist aesthetics]. In the current disarray and vacillation, we can notice new connections, a new structure, and new artistic possibilities.<sup>6</sup>

By the next All-Union decorative art exhibition, held in the spring of 1970 in the premises of the USSR Academy of Arts and dedicated to Lenin's 100th birthday, perpetual confusion and indecision were broadly recognised as legitimate facts of Soviet artistic life, mostly due to the policy of *Dekorativnoe Iskusstvo SSSR*. Reporting on the 1970 exhibition, one editorial in *Dekorativnoe Iskusstvo SSSR* deliberately addressed professionals of different persuasions, believing that a 'clash of opinions will help with clarifying the crux of the matter'.<sup>7</sup> Notably, these professionals included both critics and artists, whose view on the future of decorative art varied according to their different positions in relation to it. With regard to decorative artists who were active from the late 1960s to the 1980s, their attitude to critical concepts and debates ranged from the indulgent ('let them talk their talk, while we do the actual work') to the sceptical and even dismissive.<sup>8</sup> However, during the 1970s, *Dekorativnoe Iskusstvo SSSR* often gathered artists and critics together by publishing their opinions in one section of the journal, or in person at roundtables. In the long discussion of the 1970 exhibition that occupied the majority of *Dekorativnoe Iskusstvo SSSR*'s September issue, the artists' words appeared on the very first pages, before giving way to the critics. This contraposition signalled the radicalisation of the post-Stalin aesthetic regime of arts, based not only on equalising different arts, but on the constant tension and clash between different opinions in search of new material forms and new symbolic meanings.

Several participants in the 1970 exhibition expressed their views on the urgent practical and conceptual problems of Soviet decorative art and the mass production of household goods in response to *Dekorativnoe Iskusstvo SSSR*'s interviews. Iurii Zhul'ev, the head artist of the Vosstanie glass factory in Chudovo, Novgorod oblast', contributed to the exhibition with his utilitarian services – clean forms, easily reproducible, intended for everyday use. Though a 'man of industry', he nonetheless admitted to being susceptible to fashion, 'like all artists', and driven towards creating 'useless' objects, such as 'a still life in glass'. Justifying this desire, he referred to the 'theorists' who 'argue that decorativeness is also a function': thus, instead of dismissing the critics' vocabulary, the artist adopted it strategically to make sense of his move beyond simply serving the production line.<sup>9</sup> This alternate function was, according to Zhul'ev's reasoning, a creative response to the problem of backward technology: 'We cannot have any design until we get [proper] machines.' While the mass production of household objects was hampered by technological flaws in Soviet factories, artists could affect society by presenting the unexpected, the unusual, by producing a 'strong impression'. This impression, in turn, could be produced by metamorphoses of materiality, such as using one material to imitate another (e.g. making glass look like metal through gilding) or contrasting different materials in one artwork. Zhul'ev especially noted jewellery by an Estonian Juta Paas-Aleksandrova, the head artist of the Russkie Samotsvety factory in Leningrad. Her combination of metal and fur made Zhul'ev think not only about the Monomakh's cap, a famous Russian medieval crown stored at the Kremlin Armoury, but also of Meret Oppenheim's 'Object' ('Breakfast in Fur' 1936) – a fur-covered teacup, saucer and spoon that caught Zhul'ev's attention 'in the catalogue of some foreign exhibition'. Although, to Zhul'ev, Oppenheim's work looked 'somewhat vulgar', he believed such a provocative use of materials was a necessary stage to pass for Soviet decorative art.<sup>10</sup>

Other artists' voices, presented by *Dekorativnoe Iskusstvo SSSR*, echo this anticipation of bolder techniques. The glass artist team of Galina Antonova, Svetlana Riazanova and Antonina Stepanova admitted that designing household objects for factory production did not allow them 'to say much'. The work on unique compositions for public interiors, on the other hand, gave more room for expression. The trio preferred creating objects that were not 'habitually classifiable', but, instead, 'decorative, festive and surprising'.<sup>11</sup> The notion of festivity came to the fore in an interview with the exhibition's 'star', Boris Smirnov. He noted that the shift from asceticism to decorativeness in Soviet material culture was, on the one hand, part of the international trend towards complexity in design aesthetics, and, on the other, a response to the official mandate to design festivals to celebrate the 50th anniversary of the Bolshevik Revolution in 1967 and Lenin's jubilee. 'For three years we, Soviet people, have been

saturated with celebratory mood. We [decorative artists] have been concerned less with household objects for everyday life and more with objects for exhibitions.’ However, this was not a misfortune, Smirnov continued, in response to some worried art critics such as Iurii Gerchuk and Tatiana Semenova. Rather, this was an achievement. The frustration of an exhibition viewer, unable to find the exhibited objects in mass production, was not the artists’ fault, but the result of ‘subsidiary circumstances’, Smirnov claimed. By ‘subsidiary circumstances’, he evidently meant the rigidity of the planned economy and the lack of proper technology to adequately adapt artists’ innovative designs into mass production.

As was discussed in [Chapter 3](#), Smirnov used the forms of everyday objects not for practical usefulness but for defamiliarisation (a concept he borrowed from the literary theorist Victor Shklovsky, though not explicitly). Designing teapots with soldered lids or vessels conjoined with human and animal figures, as in his latest composition ‘Man, Horse, Dog and Bird’, Smirnov intended to defamiliarise the forms of commodities, to cause the viewer to reconsider household objects – vases, teapots, etc. – as things full of symbolic meaning. In constructing these meanings, Smirnov emphasised, matter was important: the transparency of glass allowed him to ‘defamiliarise ordinary daily collisions, to inspire thinking’.<sup>12</sup> Like Zhul’ev, Smirnov referred to the example of pre-war Western modernist art, although as antithesis rather than as inspiration. A Western readymade artist, such as, for example, Man Ray with his 1921 *Gift* (an iron with thirteen thumb tacks), was, according to Smirnov, just ‘kidding around’, not expecting a serious response from the viewer. Meanwhile, Smirnov’s teapots referenced the images of nineteenth-century Russian tea-drinking in merchant homes and taverns, described by the playwright Nikolai Ostrovsky and painter Boris Kustodiev, thus appearing as allusions to the material culture of the past, not simply trivial objects.<sup>13</sup> Smirnov refused to recognise that the Dadaists and Surrealists also rescued household objects from the banality of everyday life, as Bill Brown argues in his ‘Thing Theory’.<sup>14</sup>

Whereas the artistic voices in the 1970 exhibition seemed to celebrate ‘useless’ forms and surprise in unison, the opinions of the critics varied. Iurii Osmolovskii, an art historian specialising in painting, admitted that, in spite of his insufficient expertise in decorative art, he could see the loss of its ‘democratic-and-vital basis’ that had been no less than the ‘artistic intervention into human habitat’. Exhibited in glass cases, the contemporary objects were alienated, non-belonging and devoid of a consumer, Osmolovskii complained.<sup>15</sup> This alienation, however, was explained not as an agency of objects beyond consumer culture – a thing-power, as Jane Bennett would describe it – but by the overgrown artistic ego. The artists now addressed their objects not to consumers but to exhibitions, that is, to themselves for the purposes of self-promotion: ‘Today, looking at a cup,

we think not “what a cup!” but “what an artist!”.<sup>16</sup> Additionally, even if this cup – or vase, or teapot – is used to express a philosophy of the new everydayness (*filosofiiu novogo byta*), they fail to do so because they are devoid of a functional form. According to Osmolovskii’s logic, a perfectly useful teapot can adequately express modern everydayness, but a teapot with a soldered lid cannot – when an object ‘is trying to stop being an object’, it gets stuck between functionality and ‘pure thought’, making no sense.<sup>17</sup>

Iurii Gerchuk spoke with similar scepticism, reiterating his criticism from the previous year. Like Osmolovskii, he warned about the alienation of objects from consumption and compared the latest exhibitions of decorative art to quasi-theatrical plays. Thinking of an object as a theatre prop, an artist imagines a consumer as a mask, or even a range of different masks, and so consumption turns into a masquerade. This work cannot be serious and consistent: ‘Maybe tomorrow we’ll wish to try yet another costume.’ The rhythmic structure of these theatrical objects reminded Gerchuk of the *fin-de-siècle* art group Mir Iskusstva (World of Art) that was inspired by Art Nouveau decorativism, symbolism and retrospectivism, and also particularly by the eighteenth-century Russian variants of Baroque and Rococo. In Gerchuk’s opinion, contemporary decorative artists’ retrospective fascination with the aesthetics of Mir Iskusstva (I would call this second-level retrospectivism) was merely ‘skimming the cream’ from this heritage without understanding it thoroughly.<sup>18</sup>

Evgenii Rozenblium, co-founder and head of the Senezh studio, took a different stance. He saw a clear purpose in seemingly useless objects: creative consumption, that is, the transfer of creative impulse from an artist to a consumer. Even if an object lacks practical applicability, it can satisfy ‘everyone’s need for independent creative choices’. That is, by purchasing or even merely observing an object, one is making a creative choice. Objects for creative consumption, Rozenblium believed, could be equally useful at an exhibition, at home or at work: this position echoed the avant-gardist object that would act as co-worker and life organiser. Consequently, Rozenblium argued against the division of objects into ‘decorative’ and ‘utilitarian’ and even against the distinction between ‘decorative artists’ and ‘designers’. Instead of the professional divide, Rozenblium placed the freedom of choice between a whole range of things and their uses. He identified three kinds of freedom in designing objects: formal, relating to the creative process; functional, relating to the different ways to use an object; and psychological, allowing both the artist and the consumer to feel their creative potential. Designing objects is a social need, Rozenblium argued, regardless of material well-being. Moreover, he concluded, there was no need to worry about the proliferation of disparate stylistic references: it was not eclecticism, but a normal process of searching for the new principles of form-giving, which would eventually lead to a ‘new integrity’.<sup>19</sup>

The following commentary decisively refuted Rozenblium's optimism. Aleksandr Kamenskii, the advocate of the monumental, simple forms of Khrushchev-era painting, for which he coined the term 'severe style', dismissed the new decorative art as philistine and a throwback to the Stalinist 'architecture of excess'. There was nothing to take home from the 1970s exhibitions, he argued – both figuratively and literally – because a Soviet person just cannot dream of pretentious teapots and the like. Despite his overt criticism, however, Kamenskii unwittingly acknowledged the thing-power of the exhibits: they are 'immodest', they 'stamp their feet' capriciously, they 'flirt', as if a visitor must 'walk on egg-shells around them'. These 'thing-characters' and 'thing-fetishes' did not seem, to Kamenskii, to be capable of facilitating the 'sustainable *byt* of a contemporary person'. Thus, contrary to Smirnov's proclamation of striving beyond commodity culture, Kamenskii viewed experimental decorative art as the manifestation of commodity fetishism, as a poor alternative to the uniform, prefabricated material environment.

This strong statement, in turn, was discredited by Kirill Makarov, the foremost advocate of late 1960s neodecorativism. There are no genuine reasons for rebuking artists for 'easelism' and 'folderols' (*ukrashatel'stvo*), he argued. In defending this argument, however, Makarov acted as the antithesis to Rozenblium, with whom he otherwise shared sympathy regarding the new tendency. While Rozenblium stood for the merger of professional activities, for Makarov the distinction between them was important, because it justified the new experimentation with figurativeness and ornamentation. He tried to reassure his colleagues, who were worried about the dawn of the rigorous modernist aesthetics, that what they were witnessing was by no means the return of Stalinist grandeur:

The problem of the late 1940s–early 1950s was not the creation of unique objects, but the extension of the principles of uniqueness, figurativeness and, eventually, easel-ness [*stankovosti*] on to the whole sphere of decorative art, including mass production, which led to superficial application of decoration [*prikladnichestvo*] of all sorts.

The situation in 1970 was very different, Makarov continued, because now not only art criticism, but 'real life' demanded that there be differences between unique works of decorative art and mass-producible objects. His further suggestion to use the term 'decorative art' recalled the 1962 attempt to use it as an umbrella term for different types of art and craft,<sup>20</sup> but was now informed by the institutional and conceptual changes of the early Brezhnev years:

Today, decorative art appears in different forms: in the form of creating unique and limited-edition objects of predominantly decorative character; in the form of the products of artistic industry; in the form of mass production [based on the prototypes] of artistic engineering; finally, in the form of folk and amateur



art. This differentiation in the sphere of material-artistic production requires a differentiating approach to analysing phenomena.<sup>21</sup>

Makarov's four-part scheme – unique/limited-edition exhibits; traditional production of household items from ceramics, glass, textiles, etc. ('artistic industry'); industrial design; and, finally, folk/amateur art – was, evidently, not another attempt at ordering terms, but a championing of diversity in object-making. This was differentiation for the sake of diversification, not for the sake of control and constraint. Seen in this light, his argument was not so different from Rozenblium's: in the former, decorative art was to merge with industrial design, while in the latter it was to encompass it. Decorative art, as a summation of diverse creative activities and produced objects and as a heterogeneous 'material-artistic production', was capable of having a strong impact on society. Makarov believed that as well as satisfying everyday needs, decorative art could and should also form them; this is why he considered an exhibition as important as a shop window. The ultimate mission of decorative art is the 'transformation of our *byt'* by going above the daily routine, by diverting our attention from stressful tasks and chores to the 'integral and joyful perception of the world', by awakening 'the memory of the dear and intimate past' and by 'directing us to the future'. The past that Makarov referred to was definitely not the moral and aesthetic crimes of the Stalin era, but rather a personal, intimate past, expressible in objects and in tactile and visual pleasures. The appeal to this cherished past, safeguarded from collective trauma, is what, at the beginning of the 1970s, distinguished decorative art from the decorativism of the Stalin era. Makarov's commentary, therefore, can be seen as a rehabilitation of all sorts of decoration, even those deemed excessive by the devotees of the Khrushchev-era aesthetic turn.

The idea that prototypes for industrial mass production, unique or limited-edition exhibition-oriented objects and small series of traditional 'artistic industries' all constitute one category of 'decorative art' became the mainstream attitude in *Dekorativnoe Iskusstvo SSSR* in the early 1970s. Critics identified common principles in all these various creative professions, tracing how these same principles were shaped into the objects they produced. Sculptor Dmitrii Bisti, for example, viewed the all-Union Youth Exhibition of 1972 as the manifestation of a fundamental unity of Soviet visual culture. This was the first Soviet art exhibition to display the work of artists younger than 35, who belonged to the youth section of the USSR Artists' Union and had been organised by the Union's youth committee established a year earlier.<sup>22</sup> Held in the prestigious Manege exhibition hall in Moscow, the exhibition was remarkable due to the unprecedented combination of design projects and decorative (in the older, narrower sense) and easel art displayed together. This was possible because the exhibited design projects belonged to the Senezh studio, which was supervised by

the USSR Artists' Union, and was labelled 'artistic projecteering', meaning that it was classified as conceptual design and not commissioned designs to be mass produced. Senezh studio was unique in this regard. A design project by VNIITE, an artistic-construction bureau or a factory design service would not have been admitted into an art exhibition. However, for Bisti, a sculptor, Senezh projects represented Soviet design in general and signalled a seamless visual culture; he noticed no ruptures between the exhibition sections. His conclusion was that design and easel art were based on common principles, and as such 'designers are not some special breed remote from artists', but rather could be the very same people whose easel graphics or theatre props were on display in the same exhibition. Bisti argued that in addition to the conceptual interiors and urban environments, as in the case of Senezh studio, it was not possible to design everyday objects and machines without fundamental knowledge of the basics of visual art. His encompassing understanding of design was similar to Makarov's inclusive understanding of decorative art: it was all activities directed at shaping the material environment, including the home, the street, the workplace and all public places. Such design, according to Bisti, was based on image-conceptualisation (*obraz*). Designers and easel artists all work with composition, volume, space, and can learn from their respective approaches to these categories. Both design and easel art improve from mutual interaction and entanglement, and one can benefit from working in both professions.<sup>23</sup>

At the same time as the youth exhibition, another important exhibition, 'Artistic Glass of the Factories of the Russian Federation', was held at the Academy of Arts. This event also inspired critics to reflect on the openness and interconnectedness of Soviet visual and material culture. According to the Leningrader Nina Vasilevskaia, the anti-functionalism of contemporary artistic glass was a positive tendency, appropriate for the historical moment: 'The epoch when personal and social, the earthly and the cosmic, the contemporary and the historical are tightly intertwined in everyone's consciousness demands a new image-bearing structure of plastic arts.'<sup>24</sup> The term 'plastic arts' included easel, monumental and decorative art in all their diversity, as a single visual and material system carrying a range of meanings, from intimate to global. The border between 'easelism' and 'monumentalism' was disappearing, whereas decorative art could accommodate both characteristics. As a result, Vasilevskaia noted, decorative art transmitted artists' beliefs, and it was this 'sharp intellectualism', rather than any formal qualities of artworks, that made decorative art truly modern. Predicting the irritation of some fellow critics, she stressed that the new permeability of art was notably different than it had been for 1950s kitsch, which was exemplified by poor copies of Repin's and Surikov's masterpieces on lacquer boxes and vases.<sup>25</sup> This new 'easelism' was very serious and self-reflective.

### The artist as producer, the artist vs. production

Although this clash of opinions in *Dekorativnoe Iskusstvo SSSR* may seem abstract, it essentially revolved around the problem of bringing decorative art closer to the reality of Soviet daily life and consumer culture without damaging its artistic quality. The concerns of people such as Osmolovskii, Gerchuk and Kamenskii did not just stem from their stubborn vision of decorative art as ‘applied’ and ‘utilitarian’, but from the discrepancy between the Brezhnev government’s celebration of socialist consumption and the systemic failures of Soviet light industry to provide desired goods to everyone. Prime Minister Aleksei Kosygin’s reforms were intended to boost production by introducing some flexibility and incentives for the workers, but they proved untenable and were abandoned by 1970. While commitment to citizens’ prosperity was Brezhnev’s strategy to oppose the voluntarism of his predecessor and maintain his own popularity, the quality of consumer goods could not steadily grow because of systemic industrial flaws, such as outdated equipment, poor supply of materials, and the ongoing prevalence of quantitative plan indicators that precluded qualitative improvement. At the same time, as Natalia Chernyshova demonstrates in her study of Brezhnev-era consumption, by the 1970s Soviet people had grown more familiar with Western consumer goods through exhibitions, films, literature and because of the increasing number of imported goods from Western and Eastern Europe, however limited. This made them more discriminating and demanding consumers who were not willing to simply grab whatever the shops were selling. They wanted more and expected the government to be true to its promises.<sup>26</sup>

Given this change in Soviet consumerism in the 1970s, bold experiments by decorative artists might have indeed appeared as nothing more than self-gratification, annoying consumers. It was clear that simple appeals to the social duty of artists would not change the situation without a significant improvement in the condition of artists’ work in industry. Therefore, the *Dekorativnoe Iskusstvo SSSR* editorial team understood that it was not enough to publish disputes among artists or to reiterate the 1920s slogan ‘into production’ repeatedly. In the early 1970s, it seemed necessary instead to highlight the major tensions between artists and other factory employees and detail the urgent problems of production, in order to find possible solutions to the ongoing professional conflicts at factories and render artists’ bursting creativity actually useful in mass production.

In 1970 the journal covered a conference held as a joint event with the Jubilee exhibition that was dedicated to the problem of artistic labour in industry. Organised by the Soviet Academy of Arts, the Artists’ Union and the Ministry of Culture of the USSR, the conference brought together artists working in factories, art critics and government officials from var-

ious levels.<sup>27</sup> In his welcoming speech, the president of the Academy of Arts, sculptor Nikolai Tomskii, brought up the troubling dilemma of Soviet decorative art: the general increase in artistic creativity and the quality of designs had little actual effect on mass-produced products. He more or less reiterated the official view that decorative art was creative work in the service of the economy, according to which no daring design could go 'merely' to an exhibition or be placed in a public interior. All successful works of decorative art must 'necessarily go into production and be available either in limited edition or in large circulation' and thereby offer 'everyday joyful companionship' to people. However, this would not be possible until both the financial and technological profiles of industry were determined by stylistic tendencies and quality standards. Such a hierarchy of settings, in turn, was possible only by giving artists more power in decision-making. The chief artist (*glavnyi khudozhnik*) should have the status of art director at a factory, equal in status with a technical director. The position of the artist in industry must finally be solidified by a consistent decree, and all factories producing household objects must institute an official position of 'artist-productivist' – here, Tomskii used the exact term as it had been used in the 1920s. Leonid Karateev, the secretary of the Artists' Union, added that unique experimental works and prototypes for mass production were 'the two inseparable sides of one whole process of the development of Soviet decorative art'. The glass artist Svetlana Beskinskaia made some practical requests: more room for creative work in factory workshops, the artists' right to have free copies of their own work, and regular industrial design exhibitions in addition to decorative art exhibitions. The main suggestions of the conference were forwarded to the relevant ministries.<sup>28</sup>

The discussion progressed to the next stage in 1973, when the Academy of Arts hosted an exhibition for Russian artistic glass factories and the Leningrad Factory of Artistic Glass celebrated its 25th anniversary. The problem of art in production now involved material, financial and administrative aspects. Since the mid-1960s, glass art had been the leading arena of innovation in Soviet decorative art and the most noticeable material used in neodecorativism. Boris Smirnov, thanks to his daring 1960s experiments with surprising and defamiliarising objects, appeared in *Dekorativnoe Iskusstvo SSSR* as the driving force behind glass as an avant-garde material. While other glass artists, too, did receive attention in the journal in the 1960s, the 1973 issues presented for the first time a comprehensive panorama of artists' profiles which included current social and economic challenges. Congratulating the Leningrad Factory of Artistic Glass – the leading producer of unique and limited-edition lead glass items – on its 25th anniversary, the *Dekorativnoe Iskusstvo SSSR* editorial team emphasised the importance of good management for maintaining efficient cooperation between different specialists. Honouring such veterans

of the 1920s and 1930s Russian avant-garde as the previously mentioned Smirnov and Eduard Krimmer, a student of Kazimir Malevich, who had worked for the factory since its opening in 1948, the editorial presented their work as artists as being inextricable from the administrative skills of the factory's director Ivan Dmitriev and art director Ekaterina Ianovskaia.<sup>29</sup> It was thanks to Dmitriev's expertise as a professional chemist, the editorial stated, that the factory was approved by the Ministry of Trade in the late 1940s to start working on lead glass production that was costly and labour-intensive, but also visually impressive. In 1965 Dmitriev obtained permission for the factory to end the production of regular glassware altogether and become a specialised producer of high-quality lead glassware.<sup>30</sup> This new specialisation entailed the 'steady expansion and updating of the variety of goods' and strengthened the Leningrad factory's tradition of close cooperation between artists, manufacturing technicians and craftspeople – glassblowers, grinders and engravers.<sup>31</sup>

The Leningrad Factory of Artistic Glass became the first in the Soviet glass industry to test the Kosygin reforms by introducing welfare and bonuses for innovations in design and technology. As a result, the factory's production was completely updated by the early 1970s, and even though the government discontinued the reforms on the all-Union level, Dmitriev continued to stimulate technological and artistic modernisation in the factory. As the art critic Nikita Voronov stated enthusiastically, 'the artists could [better] see their goal when their ideas became embodied in real objects' – not only due to the greater freedom in planned targets, but also due to Dmitriev's introduction of 'creative days', when artists could focus on their experiments, and by increasing the number of research trips.<sup>32</sup> For her part, Ianovskaia demonstrated a striking combination of artistic and managerial skills, giving 'keen attention to each artist' and channeling their different personalities towards common practical goals.<sup>33</sup> The cumulative effect of economic incentives, the support for artistic experimentation, and the cooperation between different specialists made the Leningrad Factory of Artistic Glass a role model for the Soviet artistic industry: the factory provided limited-edition and medium-scope collections for retail trade while also receiving numerous awards at domestic and international exhibitions.<sup>34</sup>

The tone of *Dekorativnoe Iskusstvo SSSR* in the editorial suggested that even though Ianovskaia and Dmitriev were outstanding managers, they were not unique: every administrator, with due effort, could raise their factory's production to the same level of success. In the meantime, the factory administration could boast to foreign delegations: 'Objects that are true works of art had been recently considered exhibition pieces, but now they are available for wide consumption.' Leningrad lead glass – or 'Leningrad crystal' – became an internationally known brand not only through exhibitions but also through high-quality household goods avail-

able almost everywhere – at least in all major cities – from Ukraine to the Russian Far East. Moreover, the factory leadership was sure to note that ‘people in Italy, the Netherlands, Sweden and Finland can buy goods with the label of the Leningrad Factory of Artistic Glass’.<sup>35</sup> By the time the government increased the import of goods in an effort to mitigate the growing consumer crisis,<sup>36</sup> the practice of exporting goods – even though on a very limited scale – was already outstanding and benefited the factory’s reputation within the Soviet Union. While this success story may sound like a typical case of Soviet exaggeration, the archival records of a consultation of factory employees and trade workers in 1973 demonstrates that the latter were satisfied with the timely supply and high quality of the products, although they still identified areas for further improvement.<sup>37</sup>

This success story by no means obscured the ongoing tensions between artists and other workers in factories. On the contrary, it provided a convenient opportunity to highlight them. Praising the scope, diversity and clear composition of the exhibition ‘Artistic Glass of the Factories of the Russian Federation’ that had grown out of the 1970 conference on artists in industry, *Dekorativnoe Iskusstvo SSSR* urged its readers to ‘think about unresolved problems’. ‘When, at last, will glass factories produce medium and large editions of the objects which, just like exhibition items, demonstrate the hard work and fantasy of artists?’ inquired the editorial, directly addressing the Soviet Ministry of the Industry of Construction Materials.<sup>38</sup>

To lend credence to this issue, the journal published artists’ answers to a questionnaire it sent out – artists currently employed at different glass factories – over several issues in 1973 and 1974. The questions proceeded from the general to the particular: from the meaning of the medium (the expressive potential of glass and its role in shaping the environment) to individual creative goals, to the artist’s relationship with production (‘How do you manage to work both on unique pieces and on prototypes for mass production at the same time?’), to, finally, future plans and projects. The first question revealed the affective relation of an artist to his or her material: the intertwined recognition of its ‘thing-power’ and the will to master it. This dialectic was made especially vivid in the response by Adolf Kurilov, an artist at the famous Gus’ Khrustal’nyi factory (Vladimir oblast): glass ‘can be cut, moulded, faceted, etched, blown, engraved, glued, frosted, and fused with ceramics; one can paint over it with a brush and draw on it with carbide pencil ... It can be opaque, transparent, coloured and colourless. I do not know what other material has equal capabilities.’ Glass ‘intrudes’ into the environment as ‘boldly’ as do wood, metal and ceramics, and can eventuate not only as dinnerware or windows, but as ‘entire walls and skyscrapers’. Here Kurilov alluded to the strong utopianism of the Russian avant-garde, revived during the recent obsession with modernist clarity and transparency.

Other responses feature more intimate and less ‘corporeal’ visions of the material: according to the Leningrad factory artist Aknunii Astvatsaturian, glass is an ‘amazingly poetic material’ that can take any form, while for the Moscow artist Svetlana Beskinskaia, glass was the medium for transmitting one’s thoughts and feelings.<sup>39</sup> Boris Smirnov, who was usually very attentive to the sensory qualities of glass, gave a strikingly anthropocentric answer: glass by itself is no more special than any other material, because it is always the artist who has the upper hand and who must stay ‘above’ the material.

When it came to the ‘unique vs. mass-produced’ dilemma, all the responses leaned towards some sort of compromise. For Kurilov, the design of mass prototypes was ‘labour’, while unique works were the expression of ‘a soul singing’. When the soul is out of songs, an artist should turn to *massovka* (a rather pejorative term for mass production). So, according to Kurilov, mass production was not a noble duty but a constant obligation. He added, however, that production plans sometimes interrupt creative work on unique pieces, pressing an artist to resort to mass-producible prototypes. This would obviously mean silencing the singing soul.<sup>40</sup>

Other responses, though, were more positive towards prototypes for mass production. Svetlana Beskinskaia, the chief artist of the Glavsteklo (Main Administration of the Glass Industry) at the Soviet Ministry of Industrial Construction Materials and the secretary of the board of the Soviet Artists’ Union, characterised the work of a factory-employed artist as a ‘single, seamless process’:

When working on a unique piece, I find new solutions for mass objects. The work on a mass object [*massovoi veshch’iu*] is a necessary training of creativity, and the rigidity of the factory conditions charges and activates the thinking. I consider production the best and only basis for the true tempering of an artist.

Using the popular term from the 1920s–1930s – ‘tempering’ (*zakalka*) – Beskinskaia presented a modernised version of the myth of the New Soviet Person shaped by hard work and education.<sup>41</sup> This argument, however, was less motivated by personal beliefs and more by Beskinskaia’s status at Glavsteklo, which she headed in 1966 and wherein she initiated the ‘Resolution on artists in the glass industry’ that secured benefits for artists and gave them access to research trips. Dedicated to strengthening ties between artists and technical workers in factories,<sup>42</sup> Beskinskaia needed to present industrial production as beneficial and even necessary for one’s growth as an artist. She even stated that her dream was to find an end to the seemingly interminable debate over ‘mass vs. unique’. Beskinskaia had belonged to the staff of the Diat’kovo glass factory (Briansk oblast). Her colleague at this factory, Viktor Shevchenko, seconded her opinion on the indivisibility of unique and mass-producible objects in design: ‘I believe an artist who cannot establish good relations with production is also inca-

pable of solving the simplest creative task.' Likewise, Stepan Moiseenko, an artist from an older generation at the Vosstanie factory (Chudovo, Novgorod oblast'), optimistically noted that what is unique today can become mass production tomorrow, claiming that he always worked on unique pieces with mass-reproducibility and broad availability in mind.<sup>43</sup>

A particularly noteworthy part of this discussion was the relationship between artists and industrial workers, who, possibly alluding to the 1920s, were often called 'productivists' (*proizvodstvenniki*). Many artists called for closer cooperation. Leida Jurgen, one of a cohort of Estonian artists who had joined the Leningrad Factory of Artistic Glass in 1955, argued that only a team of specialists from various professional backgrounds could successfully solve the problems of artistic glass production. The Moscow artist Vladimir Filatov called for building a relationship of artists with industry on the basis of 'mutual respect and understanding of [common] interests, aims and needs'. Smirnov, who worked in many different areas of art and design simultaneously, acknowledged glassblowing as the truest embodiment of creativity. He described his cooperative work with a glassblower as 'the most interesting: this is an exceptional opportunity to directly and naturally enrich art by incorporating the artistry of the glassblower, naïve and free, untouched by the informational chaos from different channels, from which an artist has no means of relief'. This romanticisation of a craftsman's unalienated labour, free from the baggage of art theory, may be seen as condescending rather than respectful. However, it does make the glassblower more visible in the professional discussion. In her cultural history of glass in Russia, Julia Chadaga analyses glassblowing in new materialist terms, as a site of affinity between the human body and the material, of 'corporeal associations' that glass often produces. She cites the historian Isobel Armstrong who 'juxtaposes the invisibility of the glassblower with the unseen bubbles left in the glass as traces of the worker's breath, his presence'.<sup>44</sup>

For Smirnov, this corporeal presence of a glassblower, symbolically presented in his 1961–62 'Glassblower's triptych' (figure 3.2), was, in a way, superior to the intellectualism of the artist, but only in combination could the two be used to produce high-quality objects. Even though, as critic Alla Pavlinskaia noted, Smirnov always insisted that he was 'not a glass artist but an *artist*' (*ne stekol'shchik, a khudozhnik*), he also was continuously fascinated by folk, amateur and 'primitive' art, as is apparent in his 1970 book *Artist on the Nature of Things*.<sup>45</sup> In her article celebrating Smirnov's 70th birthday, Pavlinskaia regarded this alleged contradiction as a sign of his professional strength: 'The simplicity and naivety of folk art looks surprising in the works of such an intellectual artist. But this fascination is not accidental, and it is devoid of artificiality and stylisation, which are so frequently found in today's art.'<sup>46</sup> The embrace of folk simplicity



made Smirnov's work, as it were, immune from the 'capriciousness' that alarmed quite a few art critics at the time.

After quoting factory artists who had participated in the 1973 glass show, *Dekorativnoe Iskusstvo SSSR* dedicated an entire issue (October 1973) to the problem of the mass production of household objects. This special issue was opened by an article by the VNIITE design theorist Leonid Pereverzev. The article began by asserting the importance of thing-power:

the ready objects, like all other products of human activity, gain relative independence and start living by their own principles. People have to comply with these principles as long as they have no possibility to change the structure of the artefactual world [*veshchnoho mira*] in the direction they find desirable and necessary.

However, Pereverzev went on, the structure of human-object interrelations depends on a complex network of factors, including individual and group identity, social status, and production conditions and economic goals. Moreover, while many artists were praising handicraft as more symbolically potent than mass production, only the latter can be the 'main source of objects' in the contemporary world. While acknowledging the flaws of Soviet industry, which often refused to accept new prototypes, Pereverzev cautioned readers against blaming outright 'engineer-productionists' for the poor quality of Soviet goods. 'Instead', he suggested, 'we should ask if artists and designers recognise their share of responsibility for the deformation and de-aesthetisation of the contemporary artefactual world, and if they use all their knowledge, skills and capacities to solve this problem.' Readily assuming the role of a misunderstood genius, factory artists overlook 'the fundamentally different means of form-giving, hidden in technology'. Closer contact with engineers and 'dialogue and cooperation with up-to-date industrial technology' was necessary for artists and designers to make substantial contributions to modern culture, Pereverzev concluded. His article implicitly acknowledged thing-power not only as the (relative) self-sufficiency of objects-as-things, but also as the power of technology in guiding a designer.<sup>47</sup>

The following pages of the issue featured an editorial statement arranged in a 'ladder' fashion, akin to earlier avant-gardist manifestos and futurist poetry:

TODAY  
THE TASK  
IS FORMULATED  
AS FOLLOWS:  
TO INCLUDE THE MACHINE  
IN THE CIRCLE OF  
HABITUAL  
ARTISTIC  
MEANS

ALONG WITH THE BRUSH  
THE CHISEL  
THE POTTER'S WHEEL;  
TO PROVE  
THAT  
A MACHINE-MADE  
MASS-PRODUCED OBJECT  
CAN BE  
ON A PAR WITH  
HANDMADE OBJECTS.<sup>48</sup>

As the editorial team explained following this statement, it refuted the common belief of artists that the production process 'spoils' their designs, arguing that the artist is not the sole author of the object – he or she shares this role with the factory directors, technicians and craftspeople. 'On the way to the consumer', the editorial explained, 'the object acquires new authors, who leave their imprint on it.' Perhaps unwittingly, the editors invoked the concept of 'the biography of the object' made by the avant-garde theorist Sergei Tretiakov in 1929: an object passing through the hands of a range of people acts as a measure of their collective emotions and the dynamics of social relations.<sup>49</sup> A late socialist object was a product of a whole collective and a participant itself in cooperative labour.

The editorial's emphasis on how multiple authors leave their imprint on an object was also close to a theory proposed by the design historian Kjetil Fallan: an object's original script, devised by a designer, changes in the process of production.<sup>50</sup> The notion of a script originally came from the sociologist Madeleine Akrich, who argued that designers 'inscribe' their vision of the world in the technical content of objects they design. Fallan suggests not limiting 'script' to technical content, but rather seeing it as the designer's intentions, including 'utilitarian functions, aesthetic expressions, social meanings and cultural identities'. Thus understood, the script does not define the object for its entire lifespan: 'there is always the chance that the actors do not play the role the designers ascribe to them'.<sup>51</sup> Fallan further discusses mediation and consumption as the sites where the script undergoes changes and challenges. The articles in *Dekorativnoe Iskusstvo SSSR*, however, suggest that, even before an object reaches the retail trade its script is significantly modified by technicians and engineers. Those workers, the editorial team wrote, do not try to take away authorship from decorative artists and designers, but instead would name industry as the real author of objects.<sup>52</sup> In this understanding, the power dynamics of the factory unfold between non-human agents: industry, enforced by modern technology, produces objects for mass consumption, while people from different professions should adjust their plans and ambitions to this process. More precisely, modern industry here plays the twin role of tool and guide. Accordingly, rather than sticking to the pitiful position of a

misunderstood genius, the decorative artist or designer should modernise their attitudes to see the machine as their main instrument and the whole of industry as their workshop. Industry would then be able to ‘understand its goals aesthetically’, moving past simple production quotas to manufacture objects that would comprise the real world of high-quality goods.<sup>53</sup>

To illustrate their argument about the central role of technology in shaping objects of mass consumption, the editorial staff of *Dekorativnoe Iskusstvo SSSR* went into production, collecting joint interviews with artists, administrators, engineers, technicians and craftspeople. The first published interview related to glass – the material that had been in the spotlight in art and design criticism and was at the forefront of new design tendencies. Svetlana Beskinskaia, the chief artist at Glavsteklo, spoke with Boris Pozin – Glavsteklo’s deputy director and the head of the Planning Department at the USSR Ministry of Industrial Construction Materials – on behalf of *Dekorativnoe Iskusstvo SSSR*. Noting that glass production was developing exponentially and that the number of factories was growing, Pozin emphasised that the goal of the Soviet glass industry must be to produce more goods ‘at a high artistic level and in a single aesthetic mode’. To achieve this goal, factories must provide artists with time slots for ‘personal creativity’, so that they can work on unique exhibition items and thus polish their skills and be more efficient for mass production. Though she lauded Pozin’s intentions, Beskinskaia objected that participation in exhibitions, domestic and international, was by no means a ‘personal’ affair. She argued that exhibitions provided great opportunities for professional networking and the exchange of knowledge, which is as necessary for artists as their ‘daily bread’. In addition, travelling to exhibitions gave artists the opportunity to root around local home accessory stores and become more familiar with the realities of markets and retail at home and abroad. Welcoming these provisions, Pozin also suggested dedicating the meetings of the Glavsteklo Artistic Council not merely to assessing prototypes but also to discussing the current agenda with artists and engineers: ‘opinions will clash, and [thereafter] contacts will solidify’. Here, at Glavsteklo, art and industry seemed to achieve a blissful union, with all the agents of production working in harmony.<sup>54</sup>

However, despite these discussions, *Dekorativnoe Iskusstvo SSSR* portrayed an image of the artist in production that was far from saccharine and propagandistic. The editors admitted that, in practice, the relationship between the artistic collective and the administration at a factory could be painful. For example, at the Konakovo faience factory, an old centre of the ceramics industry in the Tver region, 90 per cent of the products consisted of crude dishware with primitive decoration, hand painting had been almost abandoned, underglaze painting had been almost totally discontinued, and faience figurines had completely disappeared. As a result, this previously renowned factory had nearly lost its artistic reputation.

Asked by the journal for the reasons for such failures, the deputy director Anatolii Likhonnikov simply responded that the factory had 'more important things to care about than artistry' – namely, an urgent need to satisfy the market with practical crockery. Sophisticated decoration methods slowed down production, and so the factory's administration had its artists designing patterns for stencils and stamping. 'We work in a large enterprise, not at an experimental factory', he reminded *Decorativnoe Iskusstvo SSSR*, 'therefore let the artist not be offended when I call them factory workers the same as everyone else. We work to supply the population with crockery.' In light of the chronic failure of Soviet crockery production to meet demand, Likhonnikov's arguments sound reasonable rather than arrogant. The common practice of crockery producers in the 1960s had been to produce labour-intensive, lavishly decorated objects, which would have been more expensive. Since the planned production value was set in terms of retail price, it was easier to fulfil by producing fewer expensive goods than a large amount of more affordable and practical ones. As a result, crockery factories technically fulfilled production requirements, but in reality expensive items remained unsold in warehouses.<sup>55</sup> Compared to this practice, Likhonnikov's attitude seems to have had a healthy dose of pragmatism, as did his treatment of all factory employees as equal in decision-making. The wider mechanisation of production processes, the replacement of crucibles with tunnel kilns and the introduction of stamp machines, he stated enthusiastically, enabled them to produce 109 million items per year.

Here, however, the artist from the Konakovo factory, artist Nikolai Kokovikhin, stepped in to contradict Likhonnikov, suggesting that mechanisation lowered the quality of goods and, hence, their saleability. Their product was failing to meet 'elementary artistic requirements'. The objects that were accepted as prototypes for mass production in the 1960s, when Kokovikhin joined the factory, would now be dismissed as too complicated and only feasible as unique exhibition pieces, a lowering of standards obviously harmful to the factory. No urgent tasks and targets, he insisted, could justify the neglect of experimental, creative work, which was not an indulgence of artists but the 'avant-garde of production'. Prioritisation of production goals marginalised creative work by reducing artists' tasks to devising stencils for standard decoration. Another important problem was the shortage and overburdening of patternmakers. Moreover, Kokovikhin complained, the USSR lacked special schools for patternmakers, engravers and painters for the ceramics industry, and these professions were gradually disappearing. As for the modernisation of technology, it was done at the expense of quality: tunnel kilns could not compare with crucibles in firing experimental pieces. Furthermore, even new machines, such as the English Murray Curvex for decorating flatware rims, could not be used to its maximum capacity because of a lack of high-quality dyes and

binders and, again, the shortage of properly skilled technicians. Clearly, while for the administrator the main bottleneck of production was artists' undue focus on 'individual' creativity, for the artist it was a neglect of professionalism coupled with the technical deficiencies of the factory.<sup>56</sup>

A similar polemic over the role of technology in the development of decorative art unfolded between Liubov' Pavlova, the senior engineer at a leading metal kitchenware factory, and the VNIITE theorist Evgenii Shchedrin. While Pavlova expected an artist to be a 'technologist' – in the sense of someone who learns and adjusts to existing technology – Shchedrin believed that an artist should be ahead of technology in order to satisfy the needs of consumers, not the requirements of the industry. Experimental work should be the driving force for updating technology, he argued, and production plans should include small experimental press-runs that would lead the way for technical modernisation. The editorial approved of this proposal: 'if currently new compositional suggestions from an artist-designer, which demand the reconstruction of technology, often hamper the fulfilment of the big industry's economic targets, special experimental forms may reveal the factors for stimulating and improving the technology of industrial production'. Small experimental series, they concluded, could facilitate many of the issues where artists and industry needed to compromise and find mutual understanding. Should that become reality, the debate on what should lead – art or technology – would become irrelevant.<sup>57</sup>

The critic Nikita Voronov further developed this proposal. According to him, the key problem in the relationship between artists and factory administrators was a mismatch of priorities and even jealousy. Artists often joined the factory at the start of their career and used the opportunity to take part in exhibitions and research trips as much as they could, provided by their employer. If an artist demonstrated both talent and networking skills, he or she would receive commissions for unique artworks for public interiors and would be allowed to go abroad as a part of the Artists' Union delegations, and receive publicity in mass media – in short, increasing the artist's social capital. For the factory administration, the success of the factory's artist could mean that they became distracted from production goals, and so the employer would have to cut down on the artist's time for research and creative work, participation in exhibitions and bonuses. Thus, the conflict between artist and administrator was not only economic and disciplinary but also psychological. Voronov referred to it as the opposition of 'the two structures of consciousness': one 'notional' and 'scientific-technological', another 'impressional' and 'artistic'. This clash, he argued, could be resolved in 'production culture': the organisation of workflow to prioritise the continuous updating of the variety of goods.<sup>58</sup> Such a production culture implies that artists focus not on style, but on the adequacy of their designs to changing daily lifestyles. For example,

rather than designing a mass-produced imitation of faceting for a drinking glass, an artist should consider whether people in the future will need drinking glasses at all. To reach this prognostic sort of thinking, the factory needs ‘mediators’ between artists and engineers: sociologists, merchandise experts and ‘object researchers [veshchevedy], specialists on material culture’.<sup>59</sup> Based on research and perfect organisation, future-oriented and interdisciplinary, the production culture envisioned by Voronov guaranteed the steady and constantly changing stream of comradely objects.

### Talkative things

A new ‘production culture’ that would finally act on the 1920s productivist vision of the role of the artist in a socialist society was one scenario promoted by *Dekorativnoe Iskusstvo SSSR* on behalf of the professional community. Alongside it, critics continued to develop the idea of a soon-to-be hybrid form of material culture that would incorporate decorative art, easel art and design. These discussions tended to move away from production and consumption, focusing instead on the formal, sensory and ‘spiritual’ qualities of objects. Critic Nikita Voronov himself spoke of the progress ‘from pure form to image’ in decorative art shown at exhibitions.<sup>60</sup> In this process, he noted, the critics’ favourite material, glass, was ceding its leading role to ceramics. While some artistic experimentation had already occurred in this material before, ceramics was now witnessing ‘the birth of something new’: a ‘non-canonical attitude to the determinants of decorative art – material, colour and form’. Symptomatically, in the spring of 1972 a group of young artists worked together on an experimental project at the Moscow Experimental-Creative Production Centre under the guidance of Adrian Bortsov. The resulting small exhibition and the participants’ later appearance at the all-Union Young Artists’ show and the Soviet Russia exhibition demonstrated a striking novelty. The diversity of the exhibition was, for Voronov, an advantage: some artists emphasised the material, presenting objects that were ‘ceramics to the core’, others demonstrated painterly and sculptural qualities; some artists focused on colour in their works, others emphasised spatial relations. All of this did not signal eclecticism, but rather progress towards a new synthesis of art that allowed for a multiplicity of combinations: ‘painterly plane combines with relief and volume, sculptural volume with spatial colour, and natural thingness [*natural’naia veshchnost’*] with illusory space’.<sup>61</sup> Apparently speaking of this new synthesis, Voronov referred to the material environment of late socialism beyond the factory floor, shop windows and prefabricated flats.

The impulse for ‘synthetic’ and non-utilitarian ceramics came, unsurprisingly, from the Baltic region, which since the 1950s had set the tone for Soviet decorative art. In 1971 Vilnius was the first Soviet city to host the All-Union Symposium of Ceramic Artists (the first such conventions of

ceramic artists had been held in Austria in 1965, and in Czechoslovakia in 1970). Organised by the Artists' Union of the Lithuanian Socialist Republic, the event brought together thirty artists from various Soviet republics and fourteen representatives of Soviet bloc countries, plus Vietnam and Mongolia. The symposium's theme, 'national traditions in Soviet ceramics', did not result in simple, formulaic salutes to the 'truly people's character of Soviet art', but in an eager exchange of ideas and technological know-how. For a month, the artists worked in ceramics workshops, visited traditional craft centres, talked to each other and to journalists and critics, and produced altogether 400 objects collectively. Many of these objects defied traditional ideas of what ceramics should be and featured abstract and fantastic forms reminiscent of folk clay toys, sculptures by Constantin Brancusi and ceramics by Picasso all at the same time (by 1971 Soviet artists were familiar with all of these sources due to greater access to professional literature and trips abroad).<sup>62</sup>

The Vilnius symposium was held for a second time in 1975, again with a great diversity of participants in terms of geography, age, professional credos and approach to material. According to the artist Juozas Adomonis, one of the initiators of these events, both symposia responded to international trends in studio ceramics while also demonstrating the specific styles of national and regional schools in socialist countries. Reviewing the collaborative summary exhibitions in his 1976 article, Adomonis used the term 'decorative author ceramics' (as opposed to 'household ceramics') and pointed to its relation to 'high art'. He argued that at the symposia of 1971 and 1975, 'applied-art qualities receded to the background, while the focus moved to emotional and metaphorical content, to the spatial, or, one can say, "architectural" qualities, and to not narrowly utilitarian, but the plastic nature and decorative functions of clay objects'.<sup>63</sup> Accordingly, the final discussions at the symposia announced that the traditional criteria of decorative art were obsolete, reiterating the late 1960s polemics on neodecorativism. Now, critics and artists were to learn 'to evaluate the spiritual qualities of ceramics, its connection with easel art and architecture, its new content and new beauty, its capacity to integrate to architecture'. Thus, if in the late 1950s to early 1960s the equality of easel and decorative arts was justified by the latter's practical usefulness and omnipresence in the home, now decorative art aspired to be 'big' due to its ability to achieve diverse visual effects either through or in spite of medium-specificity, and to tackle complex philosophical questions.

At the same time, Adomonis advocated preserving ties with the handcraft aspect of ceramics. Notably, many symposium participants did not stop at the design stage but worked through the entire production process, learning from craftspeople. Practical training in ceramic craft must be included in the curricula of all art and design schools, he argued, because artistic individuality should be embodied in the materiality of an object,

in the particulars of its making. In this respect, ceramics could be at once boldly innovative and perpetual: 'however saturated our daily life becomes with objects made from synthetic materials, however convenient, simple and cheap they are, people will always be drawn to crockery, to a vibrant object that reflects a thousand-year-long history and that preserves the spirit of handicraft, the folk spirit'.<sup>64</sup> Though he greatly understated the age of ceramics, Adomonis did make a good point regarding the artists' effort to synthesise tradition and modernity by creating a particular Soviet version of studio craft – the state-supported professional activity that aimed not to improve mass consumption but to reimagine ceramics in dialogue with the long tradition of the craft.

By the mid-1970s, the discussion of spiritual qualities, symbolic meaning and the expressive materiality of decorative art had become widespread. Critics, artists, designers and architects questioned the simplistic principles of socialist modernism. Their discussion generated a new theme: the talking (and 'talkative') object. Historian of science Lorraine Daston notes that, historically, things (the term she prefers) speak in two diametrically opposing ways: as idols (when they manipulate and deceive) and as evidence (when they demonstrate and testify). But this opposition, Daston argues, is misleading: both extremes 'appear to work by the same mechanisms of reversal and replacement', so that a copy may appear more authentic than the original, and an object's ability to speak the truth may in fact be a lie.<sup>65</sup>

The talking objects which were shown at Soviet exhibitions in the 1970s seem to have functioned in neither of the two modes described by Daston. Instead, these objects engaged in an intimate conversation with the viewers, where truth was less important than confidence. The objects shown at Khrushchev-era design exhibitions, like the famous 'Art into Life' in 1961, claimed to be true to their materials and to their intended, practical purposes. However, they could reach homes only through ministerial and factory bureaucracy, impeded by rigid planning and poor supplies of raw materials, as poor embodiments of original designs. Disappointed in the idea of the 'honest objects' of the aesthetic turn, critics and artists now placed value on objects that would not necessarily be simple and practically functional but could offer quiet reflection, awe and a feeling of intimacy. For example, the exhibition of sixteen young decorative artists (half of them women!) in the Yelagin Palace Museum in Leningrad, held in the winter of 1973–74, impressed the public with its subtlety. One critic characterised the exhibits at the Yelagin Palace show as 'shaded and soft-spoken', 'talking to the viewer confidently, in warm and soft tones, sometimes jokingly'. Objects such as the chamotte plate by Olga Nekrasova-Karateeva, decorated with the Cezannesque landscape of Leningrad's Summer Garden, and the campanile-shaped ceramic sculpture by Mikhail Kopylkov, aspired to act as intimate friends to the viewer, not as comrades who call loudly



to propagate new visions of everyday life.<sup>66</sup> Because of their affinity with easel art and complex imagery, these objects contrast with the mass-produced ceramics of the time that often demonstrated a continuity with the geometric forms and minimalist abstract decorations of the 1960s (plate 12).

The artists' growing preference for 'quietly speaking' objects may sound like a typical manifestation of the Brezhnev-era state-sponsored embrace of domesticity as an antidote to political discontent – what Natalia Chernyshova calls the 'Brezhnev-era domestic counter-revolution'.<sup>67</sup> However, the trope of a 'talking object' stemmed from artists' growing tiredness with the state campaign for socialist consumer culture. To be sure, in 1976 the government accepted the proposal of the Artists' Union and the Academy of Arts of the USSR to issue 'Regulations on artists in industry' that broadened the power of factory art directors in decision-making and thus raised the status of artistic personnel.<sup>68</sup> However, factory artists still refused to dedicate the majority of their creativity to mass production. Likewise, the artists who were affiliated with the Art Fund and worked under contract from state commissioners sought opportunities to release their creative drive without restraint. The mid-1970s thus witnessed a strong effort by decorative artists to create oases of freedom in the system of exhibition committees and factory production plans. Obviously, the state could effectively utilise this effort to broadcast an image of a happy and unrestrained artistic life under socialism by exhibiting the most interesting experimental works of decorative art abroad. Therefore, Soviet decorative artists' international networking grew exponentially in the 1970s.<sup>69</sup> The artists, in turn, used this cynical support of the state as much as they could in order to catch up with the international development of studio craft.

So, what did Soviet decorative art in the 1970s 'talk' about? The most successful attempt to decode the messages of the artworks produced at this time was probably the young art critic Margarita Izotova's, in her contribution to a 1978 edited volume on the mid-decade state of affairs in Soviet decorative art.<sup>70</sup> The stylistic unity of the late 1950s to early 1960s had ended completely, she argued, as had the belief in a 'paradise dense with artefacts *lopredmechennyi rail*', the door of which was supposed soon to be unlocked. As it turned out, the 'contemporary objects' were becoming not simpler but, instead, more complex and enigmatic. As Izotova noted, the artists' common interest in the construction, material and spatial nature of objects had nearly faded, because these concepts had become overused and trivialised. Even decorative art's relation to architecture, seen by other critics as one of its distinct features, was, for Izotova, negative: objects stood out as antagonists to enduring architectural modernism. Harmony was no longer an ideal, and elementary sensory qualities of materials were no longer sufficient for making a statement:

If yesterday an accidental streak of glaze, the natural structure of wood, or a drop of glass were regarded as aesthetic discoveries, and we thought that the author should just help to reveal the force of nature; if a prism, a cone, and a cylinder were so convincing in their formative value that we looked at the world through them, then today all the rhythms have been dispersed and complicated. Links between objects have lost the clarity and simplicity that now seem primitive. Our consciousness is now looking for deep and subtle conflicts, and the formal unity and elusive, seemingly sufficient harmony of the architectural-artefactual environment cannot satisfy us any more.<sup>71</sup>

1970s Soviet objects, therefore, became talkative – or, rather, chatty – for a reason. Their quiet monologues signalled their refusal to integrate into plain, modernist environments where one needs to speak loudly to be heard. Izotova pinpointed the theatricality of new decorative art as a mode to create multiple scenes, each with its own ‘micro-climate’ that was indifferent to the whole. Such scenes could emerge at the level of exhibitions or single artworks. One group of ceramic artists in Leningrad made an effort to create such an alternative order of Soviet things.

### ‘Image-ceramics’ by the One Composition group

In the bright early springtime of 1977, in a small hall of the Leningrad Artists’ Union, opened an exhibition with the light musical name ‘One Composition’ that would resound as a call for freedom for several years. There was no crowd, but not a small number visited this hall, walking among the podiums with ‘ceramides’ that were ‘useless’ as never before and incompatible with ‘common sense’. People would go there to think, laugh, marvel and ponder over the intricate puzzle in which life captured us at that time. Odd clay things grew on white plywood oases; these things sprawled, then arranged themselves in elegant lines, only to suddenly fall to pieces.<sup>72</sup>

This is how Margarita Izotova recalled the first public event organised by a group of young Leningrad ceramic artists. This group was inspired by the Vilnius symposia and the 1973–74 Yelagin Palace exhibition. From 1977 to 1986, roughly twenty artists were exhibited together informally at the premises of LOSKh – the Leningrad branch of the Artists’ Union of the Russian Soviet Socialist Federal Republic (RSFSR). Each could present only one work, so both the group and the exhibition series took the name ‘One Composition’ (*Odna kompozitsia*, or OK, as it was sometimes abbreviated). One of OK’s core members, Mikhail Kopylkov, describes it today as more than just a decorative art show; it was a gathering of ‘free artists’ who approached ceramics as visual art and used this material as a medium for transmitting their ideas.<sup>73</sup> Indeed, the group’s main objective was to take refuge from the design of commodities and focus on the formal, plastic and symbolic aspects of form-giving. They termed their pursuit *izokeramika* (‘image-ceramics’), as opposed to pottery.

However, the idea of ‘free artists’ hardly reflects the genesis and practical basis of the OK exhibitions accurately. The group emerged within the institutional system of Soviet decorative art and relied on the material supplies and technical labour that the system provided. Kopylkov himself, in his history of OK, co-authored with Izotova, admits that the system of workshop cooperatives (*kombinaty*) and Houses of Creativity, supervised by the Soviet Art Fund, provided the material foundation for *izokeramika*. These institutions were, in the words of Izotova and Kopylkov, ‘birthing homes’ for modern ceramics in many Soviet cities. As they explain, the state budget for major construction works included funds for so-called *sotskul’byt* (‘social, cultural and everyday facilities’) – fittings and interior design. The surplus from this funding was spent on commissioning various artworks from decorative artists affiliated with the Art Fund. These payments constituted the financial basis of the Artists’ Union of the USSR and covered, among other needs, the work of the *kombinaty* and the Houses of Creativity, staffed by administrative and technical personnel to help the artists realise their experimental designs. This practice of ‘indirect financing of art spheres located at the periphery of ideological control’ was beneficial for the development of cutting-edge trends.<sup>74</sup>

The major production site for the OK group was the experimental workshop at the Kombinat of Decorative-Applied Art at LOSKh, founded in 1965 by the art historian Maria Zelentsova, who was also its first director (and consistently advocated for the interests of decorative artists in the Artists’ Union and the Art Fund of the USSR). The experimental workshop attracted artists not affiliated with ceramic factories but who were working on commissions through the Art Fund, most of them graduates of the Department of Artistic Ceramics and Glass at the Mukhina School. Recent graduates could work at the LOSKh workshop side-by-side with experienced artists, while the absence of market competition allowed for the sharing of design techniques and concepts. This collective mode of working compromised the usual notion of authorship, as it was often difficult to identify the person behind a particular piece made in the workshop. Since ceramic departments at Soviet art schools did not train students in the practical drudgery of ceramics (preparing ceramic mixtures, glazes, dyes, building kilns and managing baking temperatures, and working on the potter’s wheel), the Art Fund’s workshops employed potters, technicians and tool-makers to implement the designs. The dependence of artists on potters further eroded the borders of authorship. Even if an artist refused to be just a ‘paper ceramicist’ (to use Adomonis’s expression),<sup>75</sup> learning all the technical processes and going through all the stages of production, he or she still needed the guidance of technical workers.

The Baltic region, too, played an important role in providing material preconditions for *izokeramika*. In the 1970s the House of Artists’ Creativity (the state-sponsored residential art centre that had existed since 1945 in

Dzintari, a neighbourhood in Jurmala, Latvia) became the centre of Soviet experimental ceramics. A special commission from the administration board of the Artists' Union of the USSR attended the regional exhibition and decided which artists were worthy of participating in the yearly symposium in Dzintari. Being selected was considered to be a great honour. Konstantin Rozhdestvenskii, the leading Soviet exhibition designer and student of the famous avant-garde artist Kazimir Malevich, played a significant role in the selection process and actively supported experimental ceramics.<sup>76</sup> The two-month-long symposium in Dzintari gave the artists access to intra-Soviet networking, to developments in Western studio ceramics, and, in terms of technology, to the use of high-temperature wood- and oil-fuelled firing (as opposed to low-temperature firing in the Leningrad workshops). As Kopylkov and Izotova explain, Latvian artists demonstrated their know-how, such as using soft clay strata pressed with cloth. They 'generously shared their experience of achieving different surface textures [*faktural*], salts and oxides of metals [for decoration] and other handicraft techniques, hitherto little known or unknown by Eastern colleagues until the early 1970s'.<sup>77</sup>

Furthermore, the exhibitions that ended the symposium were also attended by the Moscow-based committee who selected the best works for participation in the International Ceramic Competition in Faenza (historically home to majolica-ware that gave it the name 'faience') and at the International Ceramics Biennale in Vallauris (the home of Picasso's studio ceramics). While the Soviet presence in Vallauris was mainly extramural, the Faenza event welcomed Soviet artists personally at the insistence of Count Edmondo Marabini, an art critic and the key organiser of the competitions, as well as a communist and lover of Soviet culture.<sup>78</sup> Thus, Dzintari was a window to the West for the Leningrad artists who later formed OK.

Both production bases – the Art Fund's Kombinat with its experimental workshop and the Dzintari symposium – provided a postgraduate education for young Leningraders and furthered what the art historian Julia Gusarova calls the 'Leningrad school of ceramics'. Referring to Russian art theorists, she defines 'school' as a complex system of training artists, including formal institutional curricula, work experience and informal networking, as well as the practical realisation of this system's principles in artworks. The Leningrad school of ceramics was strongly defined by the Department of Artistic Ceramics and Glass that emerged through the conjoining, in 1955, of the Departments of Architectural-Decorative Ceramics, headed by Anatolii Mikhashevskii, an expert in ceramics technology, and the Department of Artistic Glass, led by the famous Boris Smirnov.<sup>79</sup> Upon the unification of the two, the new department was headed by the charismatic architect Vladimir Markov, who, like Smirnov, belonged to the cohort of the Architecture Department of the Ilya Repin Institute<sup>80</sup> that had been unwilling to partake in Khrushchev's prefabricated construction

campaign. As one of the leaders of OK, Vladimir Tsivin, recently recalled, Markov consistently spoke of the architectural nature of ceramics and urged students to approach designing a tea set in the same way as designing an architectural ensemble, arguing that the architectonics of useful objects influences the surrounding architectural space.<sup>81</sup>

Though the department had several strong specialists trained as architects, both women and men, its graduates singled out Vladimir Vasil'kovskii as Markov's counterpart in guiding the students. While Markov gave predominant attention to the plastic qualities of clay and work with expressive form, Vasil'kovskii favoured figurative imagery inspired by St Petersburg's architectural heritage, classic Russian literature and foreign literature, *fin-de-siècle* Russian symbolism, Greek and Roman antiquity and Russian folk art. Tsivin views the contrast between Markov's and Vasil'kovskii's artistic credos – rationality, abstraction and adherence to rules versus emotion, a penchant for vivid figuration and an urge to break the rules – as the key factor for the successful development of the department. One charismatic leader only has epigones, whereas the tension between two creative personalities provokes independent thinking, Tsivin argues.<sup>82</sup> Notably, this vision was informed by the cult of the male genius that was generally strong in late Soviet culture, particularly decorative art, despite the officially proclaimed gender equality and widespread presence of women in creative professions. Even though OK included several women, there were only half as many women as men. The gender politics of these late Soviet intelligentsia circles is a topic worthy of its own study. It is also notable that the majority of OK graduated from and/or taught at the Mukhina School.

Women, however, played a key role in starting OK. While Maria Zelentsova helped to secure workshops and equipment for ceramic artists in the Art Fund system, the tapestry artist Natalia Eremeeva came up with the idea of holding informal exhibitions displaying ceramics considered 'too daring for official shows', in the so-called 'Blue Hall' in the LOSKh headquarters. This initiative was a part of the 'intersectional club' at LOSKh, formed in 1976 as a forum for internal discussions and events. Responsible for the club's programme, Eremeeva considered ceramics to be the most advanced and critical area of Leningrad decorative art and proposed a regular, uncensored ceramics exhibition – on the condition that it would not be advertised and kept as a strictly internal affair.<sup>83</sup> The resulting first exhibition in 1977, however, soon became known to Leningrad artists of many different backgrounds and even the broader circle of creative intelligentsia. Nineteen young artists – most of them in their early 30s – could contribute to the show, the only requirement being that the works had to have a non-utilitarian character. Vladimir Gorislavtsev, Nina and Aleksandr Gushchin, Aleksandr Zadorin, Mikhail Kopyl'kov, Olga Nekrasova-Karateeva, Natalia Savinova, Vladimir Tsivin and, later, Natalia Rotanova and Vasili Tsygankov constituted the core of

the group. They invited Vasil'kovskii, an older artist, to join as a revered intellectual leader. Other inspirational figures, such as Anna Leporskaia and Nina Slavina, long-term employees of the Lomonosov porcelain factory, as well as Boris Smirnov, were not invited – the OK group presumed that these celebrated artists would not be interested in such an odd initiative of a younger generation.<sup>84</sup> Unlike senior porcelain artists, the members of OK considered porcelain to be a more traditional material and less open to experiment.<sup>85</sup>

These objects exhibited by OK had to differ substantially from the prototypes designed within contemporary 'production culture'. For the entire decade of its existence, the group persistently departed from the framework of consumer culture, even though quite a few of its members were or had previously been employed in factories and worked in mass production. OK functioned as a refuge – both from censorship and from the pressure of the planned economy. For example, in 1976 Vladimir Tsvinin had just finished his four-and-a-half-year employment at the ceramic factory in the Siberian town of Bogashevo, Tomsk oblast. Now affiliated with the Art Fund's Kombinat, he considered the improvement of daily life a 'petty utopia' and wanted to create 'useless objects' – at least, so he remembers it today.<sup>86</sup>

Initially, OK emphasised materiality. In the group's manifesto, the artist and critic Grigorii Kapelian stated:

The oldest of crafts – ceramics – was born at the moment when the dumb primary consciousness developed a sympathy for three elements – earth, water and fire, when human beings started to deeply feel the life of clay that they aroused [...] Later, creating the myth of their origin, people handed to God nothing else but clay as the only imaginable material for moulding the first human being. We are very far from the time when art coincided with the craft of survival. Industry emancipated (or alienated?) human hands from the direct material production of utilitarian objects. But ceramics, as before, remains the art that gives an artist access to the creative mystery of nature, to the basics of the creative element in a human being. Ceramics is not sculpture even though sometimes it can play this role. The origin of ceramics is a vessel, that is, the thing itself, not its depiction.<sup>87</sup>

Though this mythologising was intended as an introduction, it was in effect a conclusion, because they moved away from the ancient tradition of pottery where the material used determined the finished product. OK was bidding farewell to the utilitarian object, the vessel. The exhibition poster, which Kapelian designed to complement the manifesto, depicts a pot with a stitch, as if it were a textile, or a once-broken and then awkwardly repaired thing. The first OK show in 1977 displayed a porcelain vase by the celebrated artist Vladimir Gorodetskii in a glass case separated from the rest of the exhibits, as a beautiful relic – a tribute to the recently and untimely deceased artist. The traditional object symbolically passed

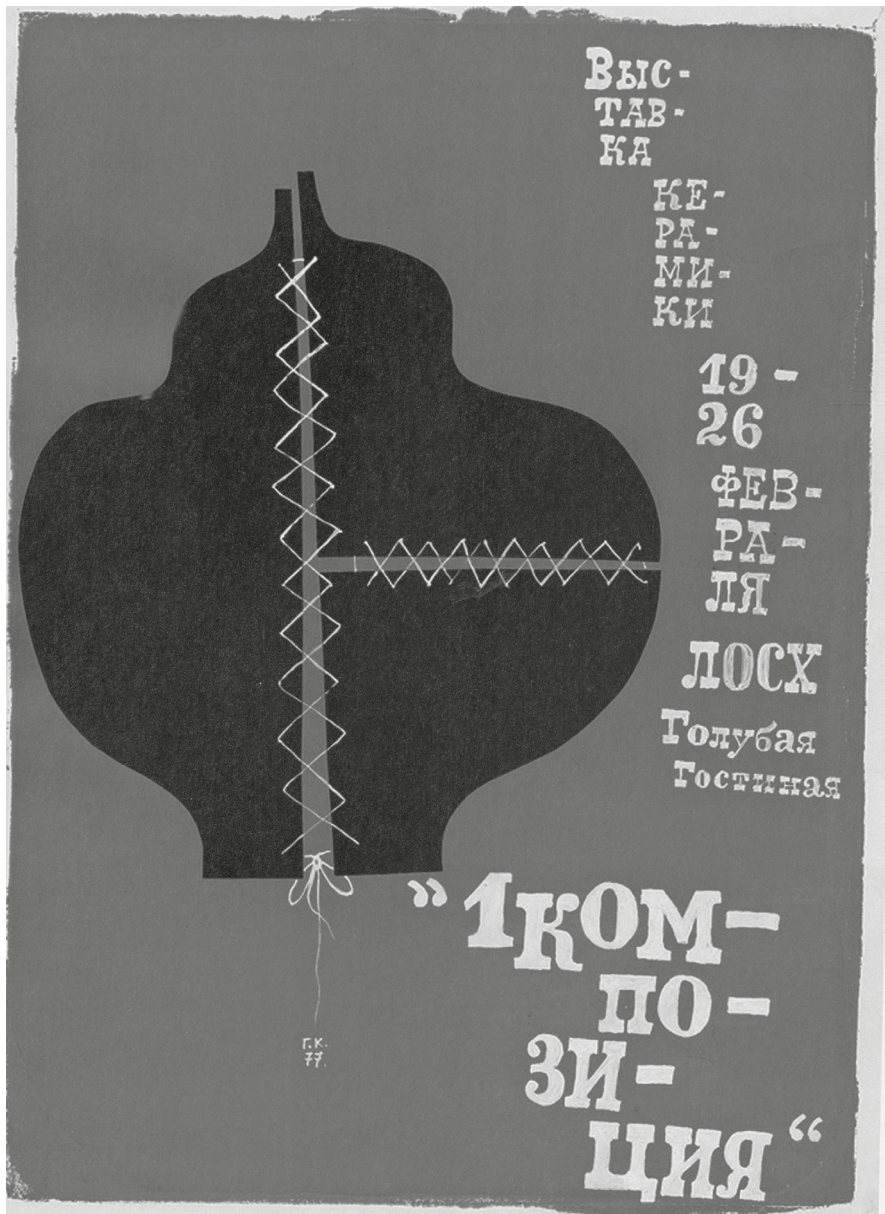

All rights reserved and permission to use the figure must be obtained from the copyright holder.

5.1 Grigorii Kapelian, sketch of the poster for the 'One Composition' exhibition, 1977.

away together with its creator; the status of avant-garde now belonged to *izokeramika*. The exhibition logo, a figure of a departing pot-seller, borrowed by Kapelian from a sixteenth-century etching by the German artist Franz Hohenberg, also symbolically acted as a point of departure. As

Kopylkov later remembered it, 'the seller was removing the pots from the Blue Hall'.

What OK offered was what I call non-commodities – objects defying commodity form. For example, at the debut OK show in February 1977, several artists used the physical qualities of different types of clay to imitate structures, colours or shapes of natural things. One of the youngest participants, Vladimir Tsivin, presented the composition 'Autumn', made in the Bogashevo factory: amphorae of different sizes, covered by shiny ochre, dark red and grey glazes, arranged on latten brass sticks. The artist explains that he was inspired by the unusually warm Siberian autumn of 1975 and viewed 'foliage as amphorae turned upside down and hills as vessels resting on their sides'. Instead of painting this landscape, he sculpted it in ceramics, following his ambition to render 'all the colours of the beautiful Siberian autumn' through antique vessels.<sup>88</sup> The resulting objects look multivalent – not just leaves and hills, but also rocks, fossils, or even reptiles of some kind. This effect could be achieved by different techniques. For example, the works of Olga Nekrasova-Karateeva and Nina Gushchina – 'Winter Morning' and 'Calla Lilies', respectively – emphasise the interplay of light and shadow rather than volume; they gravitate towards relief rather than sculpture in the round. Nekrasova-Karateeva's work was probably inspired by lessons in Cezannist and Cubist painting that she had taken with the porcelain artist Anna Leporskaia, a student of Malevich (plate 13).<sup>89</sup>

Along with 'bio-plasticity', OK challenged the commodity form by what the critic Margarita Izotova called 'portraying ordinary objects', that is, mimesis of the everyday forms and textures of non-ceramic materials such as textiles, leather, metal or plastic. According to her, the artists were enchanted by the appearance of real objects and by the magic of mimesis, and could thus see the world anew and 'erase the conventional border between art and non-art'.<sup>90</sup> Kirill Makarov described this phenomenon with a different genre metaphor: 'Animation of lifeless matter, of habitual everyday objects – chairs, armchairs, lamps, lanterns and irons – has become widespread. A still-life attitude to the world [*inatumortnoe otnoshenie k miru*] now predominates.'<sup>91</sup> Both critics carefully avoided the obvious comparison with Pop-art. However, they probably believed that the Soviet imitation of things was of a different nature: not an ironic or critical commentary, but an attempt to create dialogue between different materials, to question the difference between the tangible and the visible, to reveal the vibrancy of what is habitually perceived as *nature morte*.

The most famous example is probably Mikhail Kopylkov's contribution to the first exhibition, the composition 'Pink Dress and Autumn Coat', produced in Dzintari (plate 14). To make it Kopylkov employed the technique of pressing a stratum of chamotte (calcined fireclay) with cloth to reproduce the texture of clothes covered in autumn leaves (evidently this season was



especially inspiring for ceramic artists). As Gusarova observes, although this composition (like Kopylkov's other works) is comparable to sculpture, he works with the material in a specifically 'ceramic way': not building the volume as in classic sculpture but shaping the material at once inwards and outwards. Therefore, what may look like a Pop-art-ish imitation of another material, textile, is actually the result of chamotte's plastic potential and its interaction with cloth that made it a form-giving tool. However, the composition also depicts gendered objects, reflecting late Soviet gender hierarchy constructed and seemingly 'naturalised' through commodities. The dimensions of these objects – 111 cm high for the dress, 116 cm for the coat – reinforce this impression. Thus, we see the interplay of different materialities: of chamotte, of actual cloth and of simulated fabrics, and the gendered bodies that these fabrics are supposed to cover. As an artwork, 'Pink Dress and Autumn Coat' is immune to changes of fashion. Like Oldenburg's *Typewriter Eraser* in Bill Brown's analysis,<sup>92</sup> Kopylkov's 'clothes' are removed from fashion, consumption and craft, and 'elevated' to 'high art'.

Portraiture became an increasingly important theme in OK's exhibitions: the artists used ceramics as the medium to reflect on their everyday interactions with other people and with objects. The latter type of reflection was most vivid in Vladimir Tsivin's 1980 composition 'People and Objects' (chamotte, slipware, glaze, metal, wood and glass; produced at the Kombinat of decorative-applied art, Leningrad). Formally, it is a sculptural composition of three streamlined figures from the hips up holding seemingly random objects: a girl with a hula hoop, a boy with a magnifying glass and a featureless man with a ladder (plate 15). The first two objects represent the tools of late Soviet gender socialisation: hula-hooping was considered a proper pastime for girls, while setting fires with a magnifying glass was a popular, though reproachable, activity for boys. The symbolic meaning of the ladder is quite transparent too: the connection between earth and heaven, a difficult path towards perfection, or, more particularly, an artist's personal and professional development. The combination of these symbols gives wide room for speculation. The artist himself recently explained the essence of this work to be a contrast between stylised human figures and realistic, ready-made objects. One might further say that they act like protagonists, defining human activities and choices.

For Tsivin, however, what matters most is not the objects but the space they organise: 'they draw the border of space, the volume of air that belongs to the sculpture, captured by it'.<sup>93</sup> Objects define the direction of people's gestures, and the potential trajectory of these gestures – turning and bending of heads, movement of hands – 'charges' the space and makes it 'a field of forces'. Therefore, the artist concludes, 'this work is about people and their space, the ways they master, conquer and direct it, and the title could be "People and space"'. But I am afraid of pretentious titles, and I understand that people interact with the space through objects (even

if they are “paranormalists”).’ At the same time, Tsvin added, ‘People and Objects’ was exceptionally ‘painterly’ among his works: the slipware coloured by oxides created a fresco effect: restrained blue, pink, terracotta and white colours alluded to the artist’s fascination with medieval Russian frescoes. The painterly approach to human figures goes against the idea of ceramics as a material akin to human flesh, as the mythological origin of human beings, mentioned in Kapelian’s manifesto. Playing on this metaphor was not typical for OK: for them, human figures alluded to images from easel art rather than to human physicality, and those works that show ‘bio-plasticity’ are remarkably non-anthropocentric. In Soviet decorative art of the 1970s, ceramics appears to be less comparable to human skin than does glass. For example, the sculpture ‘Galatea’ by Adolf Ostroumov from the Leningrad Factory of Artistic Glass is explicitly biomorphic and erotic (and obviously alludes to Vera Mukhina’s 1952 glass torso achieved after a long series of efforts);<sup>94</sup> the torsos from Tsvin’s 1980s ‘Antique’ series represent Greek sculpture rather than human figures, marble and bronze rather than flesh.

‘People and Objects’, therefore, echoes a key tendency of decorative art at the time, pinpointed by such critics as Izotova and Kirill Makarov: the use of space as an active element of the composition and experimentation with sculptural and painterly techniques.<sup>95</sup> Tsvin’s people, interacting with space via objects, constitute what Izotova calls ‘artefactual theatre’ (*predmetnyi teatr*) that turns inward instead of integrating with the modernist architectural space of late socialism.

Theatre props and puppets, sculptural groups, painterly canvases and landscape architecture were all art forms that OK leaned towards in rejecting utilitarian objects. These works were often inspired by contemporary easel art – for example, Tsvin admitted that he was strongly influenced by the graphics and sculpture of Giacomo Manzù and Ernst Barlach, whose exhibitions were held in Leningrad in 1966 and in the early 1970s.<sup>96</sup> Pondering the success of the exhibition among the creative intelligentsia across the USSR, Izotova suggested that ceramics revealed the tragicomic aspect of Petersburg culture, represented by the Petersburg stories of Nikolai Gogol, as opposed to the ‘grey, cold and bleak official art’. She argued that each object here ‘frivolously’ denied its traditional function:

a plate dreamed of becoming a lake of unseen azure and generating nymphs and mermaids, pots turned into streetwise cats, clay clothes proved to be a double portrait-landscape, a chamotte ball cracked like a watermelon and ‘treated’ viewers to a fantastic still-life, a vase transformed into an urban courtyard, whereas colourful amphorae performed a leaf fall.<sup>97</sup>

However, carnivalesque imagery was only one aspect of OK’s visual language. Many of the works, produced over the ten years of the group’s activity, address such serious topics as time, freedom, faith, death and memory.



*All rights reserved and permission to use the figure must be obtained from the copyright holder.*

**5.2** Adolf Ostroumov, sculpture, 'Galatea', lead glass, sandblasting, 1977.

From the start, OK's work often showed signs of self-portrayal. The 1983 exhibition, on the suggestion of group participant Aleksander Zadorin, had a definite theme for the first time: self-portraiture. Many artists contributed installations representing themselves in studio environments (Aleksandr Gushchin, Zadorin), sculptural self-portraits as Renaissance artists (Mikhail Kopylkov, Elena Rudina), or otherwise expressed themselves through objects whose surface acted as a painterly canvas (Natalia Savinova, Natalia Rotanova, Vasili Tsygankov). Some portrayed themselves as part of a collective, such as the family (Tsivin) or the actual OK group (Nina Kochneva).<sup>98</sup> This exercise in self-reflection looks like the antithesis to Soviet production culture: the self-portraits say little about consumption and mass production. However, they do sometimes 'comment' on the position of a decorative artist in late Soviet society. For example, in her composition, produced at the Kombinat by the Leningrad potter Aleksandr Sokolov, Nekrasova-Karateeva presents herself as an angel-like figure whose creative impulse is constrained by the 'wheel' of work and family responsibilities: the inscriptions on the wheel shafts are the names of institutions (LOSKh, the Art Fund, and the Mukhina School) and of the artist's two children and husband, as well as the word 'home'. Nekrasova-Karateeva's self-portrait, therefore, embodies the double burden of a female artist under state socialism (plate 16).<sup>99</sup> Tired of the state's requirement to continuously design commodities, OK came close to institutional critique.

This critique did not focus on improving production cultures and achieving the productivist hope for setting comradely relations with useful objects. And OK's works were non-commodities not by virtue of their transparent relations with users (as the 1920s productivists would imagine); rather, these objects aspired for autonomy from Soviet economic and cultural institutions. They departed from the Khrushchev-era aesthetic regime of arts both through their diverse and provocative imagery and through their materiality. Instead of revealing the specificity of their materials, the OK artists, each in his or her own way, emphasised the properties of clay that produced sculptural or painterly effects. Today, the surviving participants attribute the group's nationwide acclaim to its universality and its status as a creator of 'image-ceramics', not of decorative art. Mikhail Kopylkov insists that 'decorative art' was just an official label, a requirement for the approval of the LOSKh authorities, while what he and his colleagues really created was a new kind of visual art.<sup>100</sup> Likewise, Tsivin identifies his work during the OK period (and later, up to now) as sculpture rather than art ceramics. Referring to his teacher and role model Vasil'kovskii, he argues that a great artist 'can be great in all media'.<sup>101</sup> While quite a few of OK's members worked in factories, the group offered a refuge from the still non-prestigious and undervalued status of the artist-in-industry. The development of the group's creative credo did not go without envy or competition, similarly to what happened

with studio craft in the United States in the 1970s–1980s when it aspired for acceptance in the art world. As Glenn Adamson et al. conclude (referring to the arguments of Garth Clark), that effort of the American craftspeople was doomed ‘partly because craft’s medium-orientation was so at variance with the conceptual and cross-disciplinary tendencies of the art world’.<sup>102</sup>

In the Soviet context, however, medium-specificity also brought envy from easel artists. The official label ‘decorative art’ often acted as a pass for formal and conceptual experiments that would not be allowed in sculpture or painting. Deciding whether to accept an artwork for an official show, an exhibition committee needed to categorise it: due to its ‘minor’ status, ceramics accommodated greater artistic freedom. Tsivin’s ‘People and Objects’ is an illustrative case. In 1985, while deciding whether it could go to a big all-Union exhibition ‘We Are Building Communism’, the Leningrad evaluation committee, composed of various honoured artists, had an argument over whether it was ‘ceramics’ or ‘sculpture’. While the painter Evsei Moiseenko suggested that it was ‘a beautiful thing’ and that labels therefore did not matter, the sculptor Mikhail Anikushin demanded clear categorisation. With the verdict ‘ceramics’, ‘People and Objects’ went to Moscow to be featured among the best Soviet artworks. Admitting that he still has no hard feelings about those numerous committees, Tsivin recently remarked ironically that nobody bothered to ask if his people with objects were building communism.<sup>103</sup> The artist implies that their looks and gestures were not directed to any communist utopia but elsewhere. In 2007 he created several variants of a clay sculpture representing a biblical theme: Jacob with the ladder.<sup>104</sup>

By 1986, when the changing political situation exacerbated differences in professional and ethical views within OK, envy grew from a motivational drive into a destructive, divisive force and the group disintegrated. Today it is remembered as a crucial, though perhaps underappreciated, group in late Soviet cultural and intellectual life. Its brainchild, *izokeramika*, was a way of interacting with contemporary trends in foreign studio ceramics (especially Japanese and British), to overcome ideological constraints and to suggest a model of autonomous material environment, or, rather, a set of diverse micro-environments.<sup>105</sup> It was, at the same time, a child of Soviet institutions with their very specific material conditions and a product of Soviet technicians and craftsmen. The objects of *izokeramika* ultimately ‘talked’, therefore, about the impossibility of full artistic autonomy.

## Conclusion

The Brezhnev government’s dedication to furthering consumer culture in order to maintain the population’s loyalty imposed a great responsibility not only on industrial designers, but also on decorative artists who were

working in traditional art industries. Concurrently, increasing access to international cultural exchange and networking stimulated Soviet artists' creative ambitions and inspired them to pursue and intensify the late 1960s trend of challenging the established criteria of what constituted decorative art. As a result, the ideal of a proper, socialist, 'comradely' object ultimately disintegrated, while mutual mistrust between artists, on the one hand, and engineers, technicians and factory administrators, on the other, deepened. *Dekorativnoe Iskusstvo SSSR*'s attempt, as a guide of the professional community, to promote a new, attractive and prestigious image of 'production culture' met with only limited success. While continuing to be dedicated to industry, decorative artists also gravitated towards experimentation with materials, forms and symbols that would set them apart from their earlier stomping grounds as mediators of mass production and consumption. Highly receptive to international developments both in studio craft and visual art, decorative artists used institutional support – in the form of workshops with kilns and the supply of clay, exhibitions, creative symposia, research trips and international competitions – as much as they could to grow as artists.

Aspiring for acceptance in the world of 'high art' and in the international community of studio crafts, Soviet decorative artists persistently tried to deconstruct the idea of a utilitarian object, resorting to non-traditional and unexpected uses of media. This aspiration was most evident in ceramics, and at the end of the Brezhnev and beginning of the post-Brezhnev period, Leningrad became the centre of a new artistic trend, image-ceramics. Applying Akrich's concept of script to this case, I argue that the artists of One Composition inscribed the burning questions of the late Soviet intelligentsia in their ceramics: the limits of personal freedom, the meaning of spirituality and religion in the modern world, collective and individual memory, the relationship between humans and nature. These scripts proceeded from the ideal of an autonomous artist, free from political, social and economic constraints. However, the implementation of these scripts was only possible because of state institutions and financing, and the physical work of craftspeople and technicians, which the artists could closely control in the Art Fund's workshops. It turns out that this script was a story of continuous interdependence between the artist and society rather than the tale of an autonomous artist.

## Notes

- 1 RGALI, f. 2943, op. 1, d. 2550, l. 53.
- 2 O. Baiar, 'Krasivoe v prostom', *Dekorativnoe Iskusstvo SSSR* 7 (1961), 1–6.
- 3 Leonid Nevler, 'Tut vse gorazdo slozhnee', *Dekorativnoe Iskusstvo SSSR* 3 (1963), 29–32.
- 4 'Vsesoiuznaia vystavka dekorativnogo iskusstva', *Dekorativnoe Iskusstvo SSSR* 9 (1970), 1.

- 5 Attfield, *Wild Things*, p. 67.
- 6 'Govoriat spetsialisty', *Dekorativnoe Iskusstvo SSSR* 1 (1969), 34.
- 7 'Vsesoiuznaia vystavka dekorativnogo iskusstva'.
- 8 Vladimir Tsvin, interview with the author, recorded in St Petersburg, 26 March 2018. I encountered similar scepticism towards the art critiques of the past in conversations with the dynasty of decorative artists in St Petersburg in the summer of 2009.
- 9 'Vsesoiuznaia vystavka dekorativnogo iskusstva', 3.
- 10 *Ibid.*
- 11 *Ibid.*, 4.
- 12 *Ibid.*, 5.
- 13 *Ibid.*, 6.
- 14 Brown, 'Thing Theory', 16.
- 15 'Obsuzhdaem vystavku. Govoriat kritiki', *Dekorativnoe Iskusstvo SSSR* 9 (1970), 9.
- 16 *Ibid.*
- 17 *Ibid.*
- 18 *Ibid.*, 9.
- 19 *Ibid.*, 11.
- 20 The *Dekorativnoe Iskusstvo SSSR* editorial from January 1962 presented decorative art as a sphere encompassing not only applied and monumental art, but also all sorts of decorative works (*oformlenie*) as well as folk crafts organised in the USSR through artisanal cooperatives (see introduction, p. 33). IAQI 'XX s''ezd KPSS I zadachi dekorativnogo iskusstva', *Dekorativnoe Iskusstvo SSSR* 1 (1962), 1–2.
- 21 'Obsuzhdaem vystavku. Govoriat kritiki', 11.
- 22 RGALI, f. 2943, op. 3, ed. khr. 581.
- 23 D. Bisti, 'Obshchnost' printsipov', *Dekorativnoe Iskusstvo SSSR* 1 (1973), 12–15.
- 24 N. Vasilevskaia, 'Tvorchestvo I proizvodstvo', *Dekorativnoe Iskusstvo SSSR* 2 (1973), 16.
- 25 *Ibid.*
- 26 This paragraph is based on Chernyshova, *Soviet Consumer Culture in the Brezhnev Era*, pp. 18–37.
- 27 'Khudozhnik i proizvodstvo', *Dekorativnoe Iskusstvo SSSR* 9 (1970), 20–1.
- 28 *Ibid.*
- 29 'Leningradskomu zavodu khudozhstvennogo stekla – 25 let', *Dekorativnoe Iskusstvo SSSR* 1 (1973), 15.
- 30 N. Voronov, 'Direktor', *Dekorativnoe Iskusstvo SSSR* 1 (1973), 17–19.
- 31 TsGANTD SPb, f. 1234, op. 11, d. 119, l. 6.
- 32 Voronov, 'Direktor', 17.
- 33 N. Vasilevskaia, 'Glavnyi khudizhnik', *Dekorativnoe Iskusstvo SSSR* 1 (1973), 19–21.
- 34 TsGANTD SPb, f. 1234, op. 11, d. 119, l. 7.
- 35 *Ibid.*
- 36 Natalia Chernyshova highlights the increase in the importation of consumer goods in the Brezhnev era: between 1970 and 1980 it doubled. Chernyshova, *Soviet Consumer Culture in the Brezhnev Era*, p. 31.
- 37 TsGANTD SPb, f. 1234, op. 11, d. 119.
- 38 'Khudozhestvennoe steklo zavodov SSSR', *Dekorativnoe Iskusstvo SSSR* 2 (1973), 12.
- 39 'Khudozhniki o svoem tvorhestve' (anketa *Dekorativnoe Iskusstvo SSSR*), *Dekorativnoe Iskusstvo SSSR* 2 (1973), 13–14.
- 40 *Ibid.*, 13.
- 41 The concept of the 'New Soviet Man/Person' has been addressed in several works over the last two decades. Some examples include Lilya Kaganovsky, 'How the Soviet Man Was (Un)Made', *Slavic Review* 63.3 (2004), 577–96, doi:10.2307/1520345; Tijana Vujošević, *Modernism and the Making of the Soviet New Man* (Oxford: Oxford University Press, 2017).

- 42 'Khudozhnik dolzhen videt' budushchee', *Dekorativnoe Iskusstvo SSSR* 10 (1973), 10–13.
- 43 Ibid.
- 44 Julia B. Chadaga, 'Embracing Stars: On the Corporeal Qualities of Russian Glass', *Russian Studies Faculty Publications Paper 2* (2012), 17, <http://digitalcommons.maclester.edu/russianfacpub/2> (accessed 2 August 2019).
- 45 Smirnov, *Khudozhnik o prirode veshchei*.
- 46 Alla Pavlinskaia, 'Talant i lichnost' khudozhnika', *Dekorativnoe Iskusstvo SSSR* 3 (1973), 35.
- 47 Leonid Pereverzev, 'Chelovek-veshch-chelovek', *Dekorativnoe Iskusstvo SSSR* 10 (1973), 1–7.
- 48 Editorial statement, *Dekorativnoe Iskusstvo SSSR* 10 (1973), 7–8.
- 49 Tretiakov, 'Biografiia veshchi'.
- 50 Madeleine Akrich, 'The De-Description of Technical Objects', in W. Bijker and J. Law (eds), *Shaping Technology/Building Society* (Cambridge, MA: MIT Press, 1992), pp. 205–24.
- 51 Fallan, *Design History*, p. 79.
- 52 Editorial statement, *Dekorativnoe Iskusstvo SSSR* 10 (1973), 7.
- 53 Ibid., 8.
- 54 'Khudozhnik dolzhen videt' budushchee'.
- 55 Chernyshova, *Soviet Consumer Culture in the Brezhnev Era*, pp. 25–6.
- 56 'Seichas nam ne do khudozhnika', *Dekorativnoe Iskusstvo SSSR* 10 (1973), 14–17.
- 57 'Khudozhnik obiazab byt' konsruktorom', *Dekorativnoe Iskusstvo SSSR* 10 (1973), 22–5.
- 58 Nikita Voronov, 'Khudozhnik i inzhener: problem sotrudnichstva', *Dekorativnoe Iskusstvo SSSR* 10 (1973), 31–4.
- 59 Ibid.
- 60 Nikita Voronov, 'Ot chistoi formy – k izobrazitel'nosti', *Dekorativnoe Iskusstvo SSSR* 4 (1973), 20–5.
- 61 Ibid., 21.
- 62 *The First International Symposium of Ceramics in Vilnius* (Vilnius: The Unions of Artists of the USSR and of Lithuanian SSR, 1973); Juozas Adomonis, 'Vstrechi keramistov v Vil'niuse', in Stepanian and Aronov (eds), *Sovetskoe dekorativnoe iskusstvo* '76, pp. 85–92.
- 63 Adomonis, 'Vstrechi keramistov v Vil'niuse'.
- 64 Ibid., 89.
- 65 Daston (ed.), *Things That Talk*, p. 15.
- 66 M. Ostroumova, 'Liricheskie obrazy', *DISSSR* 8 (August 1974), 17–22.
- 67 Chernyshova, *Soviet Consumer Culture in the Brezhnev Era*, pp. 164–5.
- 68 K. Ronskii, 'Khudozhnik i proizvodstvo', in Stepanian and Aronov (eds), *Sovetskoe dekorativnoe iskusstvo* '76, pp. 94–7.
- 69 The Vilnius symposia were attended by an Italian delegation headed by art critic Edmondo Marabini from Faenza, an old ceramics centre. From 1971, thanks to Soviet links to the French and Italian Communist parties, Soviet artists were increasingly presenting their works at international ceramics competitions in Faenza, where Marabini was the secretary, and at the International Ceramics Biennale in Vallauris, southern France, where Picasso experimented with studio ceramics in the 1940s–50s. *The First International Symposium of Ceramics in Vilnius*, p. 5; RGALI, f. 2082, op. 3, d. 859, l. 2.
- 70 Margarita Izotova, 'Predmet i ego sreda', in Stepanian and Aronov (eds), *Sovetskoe dekorativnoe iskusstvo* '76, pp. 49–60.
- 71 Ibid., p. 50.
- 72 Margarita Izotova and Mikhail Kopylkov, *Odna kompositsiia* (St Petersburg: Novaia Niva, 2011), p. 11.



- 73 Mikhail Kopylkov, telephone conversation with the author, 7 November 2018.
- 74 Izotova and Kopylkov, *Odna kompozitsiia*, p. 31.
- 75 Adomonis, 'Vstrechi keramistov v Vil'niuse'.
- 76 Vladimir Tsivin, conversation with the author, recorded in St Petersburg, 26 March 2018.
- 77 Izotova and Kopylkov, *Odna kompozitsiia*, p. 39.
- 78 Vladimir Tsivin, *Kommentarii* (St Petersburg: Avrora Dizain, 2008), p. 64.
- 79 Gusarova, 'Leningradskaia keramika', pp. 62–3.
- 80 The Institute of Painting, Sculpture and Architecture in Leningrad was the successor to the Imperial Academy of Arts. After a number of reorganisations in the 1920s, it acquired the name of the nineteenth-century realist painter Ilya Repin in 1932. A number of its graduates from the late 1930s would teach at the Mukhina School from the 1950s, in particular in the department of artistic ceramics and glass.
- 81 Tsivin, *Kommentarii*, p. 64.
- 82 *Ibid.*, p. 19.
- 83 Izotova and Kopylkov, *Odna kompozitsiia*, pp. 15–29.
- 84 Olga Nekrasova-Karateeva, conversation with the author, recorded in St Petersburg, 1 December 2017.
- 85 Izotova and Kopylkov, *Odna kompozitsiia*, p. 16.
- 86 Tsivin, conversation, 26 March 2018.
- 87 Quoted in Izotova and Kopylkov, *Odna kompozitsiia*, p. 12.
- 88 Tsivin, *Kommentarii*, p. 183.
- 89 Olga Nekrasova-Karateeva, interview with the author, recorded in St Petersburg, 17 March 2014.
- 90 'Naturstil' 70-kh', *Dekorativnoe Iskusstvo SSSR* 12 (1979), 6.
- 91 Kirill Makarov, 'Naturstil' 70-kh', *Dekorativnoe Iskusstvo SSSR* 2 (1979), 24.
- 92 Brown, *Things*, p. 15.
- 93 Tsivin, *Kommentarii*, p. 53.
- 94 Chadaga, 'Embracing Stars', 18–19.
- 95 Izotova, 'Predmet I ego sreda', 51; Makarov, 'Naturstil' 70-kh', 22.
- 96 Tsivin, *Kommentarii*, pp. 22–8.
- 97 Izotova and Kopylkov, *Odna kompozitsiia*, p. 11.
- 98 All these works can be seen in Izotova and Kopylkov, *Odna kompozitsiia*, pp. 172–88, available at [http://glassceram.ru/wp-content/uploads/2013/04/odna\\_kompozitsiia.pdf](http://glassceram.ru/wp-content/uploads/2013/04/odna_kompozitsiia.pdf) (accessed 2 August 2019).
- 99 Olga Nekrasova-Karateeva, email correspondence with the author, 14–20 November 2018.
- 100 Kopylkov telephone conversation, 7 November 2018.
- 101 Tsivin conversation, 26 March 2018.
- 102 Adamson et al., 'Modern Craft Studies: The Decade in Review', 7, citing Garth Clark, 'How Envy Killed the Crafts Movement', in Glenn Adamson (ed.), *The Craft Reader* (Oxford: Berg, 2010), p. 448.
- 103 Tsivin *Kommentarii*, p. 54.
- 104 Vladimir Tsivin, *Skul'ptura* (St Petersburg: Avrora dizain, 2008), pp. 170–4.
- 105 Mikhail Kopylkov, 'Afterword', in Izotova and Kopylkov, *Odna kompozitsiia*, pp. 314–15; Nekrasova-Karateeva interview, 1 December 2017.

## Epilogue

A considerable amount of the work on this manuscript was undertaken in Denmark, where I stayed as a postdoctoral fellow at Aarhus University in 2016–18. As one of the leaders of European product design and a country with a profound national design mythology, Denmark is a magnet for a design historian. Exploring the European context for the comradely objects of late socialism, I frequently visited the library of Designmuseum Danmark Copenhagen. One afternoon in the autumn of 2016, during a lunch break in the museum café, the librarian Anja Lollesgaard introduced me to Boris Berlin, one of the leading Danish designers and a co-founder of the well-known company Komplot Design, who started his career at VNIITE before emigrating in 1983. Berlin is closely affiliated with Designmuseum Danmark: he designed the furniture for its library and regularly participates in its exhibitions, so his visit to the museum's café was not an accident. Hearing about my research topic, he responded with scepticism, noting that there was not much good design of household objects in the USSR.

This view is neither surprising nor unique. The foundation of the Designers' Union of the USSR in 1987, the fulfilment of Iurii Soloviev's old dream, did not usher in the triumphant age of the comradely object. The political and economic circumstances of perestroika were very different from those envisioned by either the 1920s productivists or the design professionals of the 1960s to early 1980s. The establishment of semi-autonomous design studios within the Designers' Union gave the most successful and ambitious designers relative freedom from the guidelines of VNIITE and further dissolved the idea of a comradely object which was by that point seen as either naively utopian or cynical.<sup>1</sup> Meanwhile, the tendency towards studio craft and easel art forms among decorative artists grew completely apart from the goals of a changing Soviet economy. The

comradely object lost its relevance even more with the disintegration of the Soviet Union and remains an incomplete project.

This inquiry into the post-avant-garde biography of socialist objects presents an alternative to the two narratives of Soviet design, predominant in the public discourse of contemporary Russia and informed by the politics of memory about the Soviet past. One narrative is reflected in Boris Berlin's response to my research interests. It depicts Soviet design as plagiaristic, low-quality, neglectful of the consumer, or altogether non-existent. It is shared by some former employees of VNIITE who felt constrained by the bureaucratic structures of these institutions and upset that so few of their ideas could be implemented. In particular, Soloviev (who lived a long life until 2013) is remembered within the Russian design community as an odious figure – an adventurous politician and functionary (according to some mythologies, in the employ of the KGB), who aspired for personal fame rather than for real impact on Soviet production and people's daily life. The outstanding graphic designer Sergei Serov, president of the Moscow Global Biennale of Graphic Design 'Golden Bee', expressed this attitude in a 2006 online commentary on the announcement of Soloviev's then newly published autobiography:<sup>2</sup> 'I have worked in design for 33 years and spent my best years at VNIITE. But I do not want to go back to the USSR,<sup>3</sup> and I do not want to be a part of this false and mythologised history that is being written by former and current design bosses.'<sup>4</sup> Serov's colleagues, who were probably less successful in building post-Soviet design careers, remember their VNIITE experience with a mixture of nostalgia, reproach and regrets about missed opportunities. Mikhail Kos'kov, former Leningrad VNIITE designer and currently a design theorist and lecturer at the Stieglitz Academy of Art and Design (the Mukhina School's successor), criticises the Soviet design community for insufficient rigour in establishing methodologies, for its utopianism and, in particular, for its undue infatuation with 'fashionable sciences' such as semiotics.<sup>5</sup>

The negative narrative of Soviet design is supported by graphic designers who started their careers during perestroika and especially during the time of the painful restructuring of the Russian economy, when the collapse of industry precluded any development in product design, but the infant market for advertising opened new opportunities for talented and business-like graphic designers. This narrative was wholeheartedly expressed on a recent Internet talk-show by the graphic designer Irina Dragunskaja (a 1999 graduate of Moscow State University of Printing Arts) and her father, the writer and liberal journalist Denis Dragunskii. According to them, Soviet design was amoral, corrupted by the absence of rules (and thus the proliferation of plagiarism), replete with hack-work and neglectful of the consumer – part of the broader Soviet system in which 'a person was alienated from the world of things'.<sup>6</sup>

The second, positive narrative on Soviet design is centred on notions of national pride and lost heritage that should be revived and popularised. This narrative has also been recently supported by former VNIITE employees,<sup>7</sup> who expect their decades-long, painstaking work to be justly acknowledged, and by sympathetic younger designers and critics. From the latter group came a recent initiative to republicise the VNIITE legacy by establishing a Moscow Design Museum. The museum started in 2011 as a mobile exposition in a bus, inspired by early Soviet agit-trains, which travels around Moscow, and it is planned that it should tour other Russian cities. In addition, the museum organises temporary exhibitions in different Moscow settings. The museum's first exhibition, 'Soviet Design 1950s–1980s', opened on 30 November 2012, in the prestigious setting of the Manege Exhibition Hall near Red Square.<sup>8</sup> Based on meticulous archival research at VNIITE and state industrial enterprises and on contacts with VNIITE employees, including the 93-year-old Soloviev, the exhibition showcased a variety of objects – both mass-produced goods and prototypes that were never realised – as well as video-interviews with designers. The museum's director, the designer Alexandra Sankova, aimed to demonstrate to a young generation that post-war Soviet visual culture was not only propaganda and to present a complex approach to design, of the kind professed at VNIITE. As she explained, 'according to the contemporary idea of design, an object should possess at least two qualities: functionalism and consumer appeal. Is this idea compatible to the notion of "the Soviet?" Our exhibition aimed to answer this question.'<sup>9</sup> The great popularity and high attendance at the exhibition implied an affirmative answer – or, at least, the willingness of Russians to dwell on it now.

Western design historians and curators, too, increasingly contribute to this positive narrative of the history of Soviet design, but from a more critical, distanced position. They appreciate precisely what people such as Kos'kov consider to be errors: interdisciplinary approaches, drawing on the findings of philosophy and sociology, and an orientation towards the harmonisation of the environment rather than sheer profit.<sup>10</sup> In her review of the Moscow Design Museum's debut exhibition, the Swedish design historian Margareta Tillberg shifted the focus of her analysis from plagiarism and imitation to the affective power of Soviet objects:

Even if Soviet design was often – but far from always – based on originals borrowed from the West, the individual objects exude a personal charm, variation, and quiriness that makes them well worth preserving, exhibiting, and discussing. Certainly, one might think the Vyatka is merely an unnecessary repetition of the original Vespa, only heavier, of poorer quality, and, because it was not mass-produced, much more expensive. However, I still believe that the Russian-made scooter deserves more attention than it has been given thus far. It says something about a time and a system that may seem alien, but which had a tremendous impact on what our world looks like today.<sup>11</sup>

Tillberg's evaluation may suggest that in the Soviet system, the exchange-value of Soviet models, such as Italian Vespa scooters or American Hoover vacuum cleaners, was converted into what Soviet economists termed 'use-value' (*potrebitel'naia stoimost'*),<sup>12</sup> based on honest practicality and the sensory qualities of objects – their 'realism, weight, volume, and earth', to use an expression from the 1920s internationalist Russian avant-garde.<sup>13</sup> In this interpretation, the perceived immorality of designers appears instead as their great care for consumers and their wish to translate the advancements in world design into their daily environment – while working on original models, developing sophisticated systems of domestic equipment and envisioning de-artefactualisation. The stereotype of clumsy and unoriginal Soviet commodities obscures the story that took place behind and beyond them – the theoretical debates, lectures, interdisciplinary seminars and conceptually daring projects. The profound interest in this story informed Tom Cubbin's evaluation of the Moscow Design Museum's first exhibition: 'Importantly, this show makes the point that during late socialism there was a community of designers who believed that design in the Soviet Union could be a socially active discipline that would change the lives of citizens for the better.'<sup>14</sup> I hope that I have demonstrated in this book that this community was diverse and genuine in its belief in the power of objects to create different ways of everyday living and thinking. The thing-power of Soviet material culture, however, proved too complex to be managed by design.

## Notes

- 1 TsGALI SPb, f. 781, op. 1, d. 2, ll. 711; Runge, *Istoriia dizaina, nauki i tekhniki*, pp. 366–400; Dmitry Azrikan, interview for the journal *Projector*, 23 September 2008, [www.designet.ru/context/interview/?id=37621](http://www.designet.ru/context/interview/?id=37621) (accessed 17 November 2012).
- 2 Iurii Soloviev, *Moia zhizn' v dizaine* (Moscow: Soiuz dizainerov Rossii, 2006).
- 3 The phrase 'back to the USSR' was used in English in the original – as a reiteration of the announcement's title, but also, evidently, as a bitterly ironic reference to the catch-phrase resonant with post-Soviet nostalgia that developed in 2000s Russia.
- 4 A commentary on the entry in the Internet version of the journal *Kak*: Aleksandr Matveev and Vladimir Samoïlov, 'Back to the USSR', <http://kak.ru/columns/designet/a1517/> (accessed 28 March 2015).
- 5 Author's interview with Mikhail Alekseevich Kos'kov, recorded in St Petersburg, 16 April 2011.
- 6 'Dizain, kotorogo ne bylo', video recorded 17 March 2011, <http://gogol.tv/video/122> (accessed 30 March 2015).
- 7 VNIITE announced the decision to officially close its doors on 14 June 2013, but this event passed virtually without notice in the Russian press, and it still nominally exists in the same location at the All-Russia Exhibition of Economy (a successor of a famous Soviet VDNKh, whose historical name has just been revived after the area's massive reconstruction). It co-organises design conferences; in the spring of 2014 I was able to work in its rarely visited library, thanks to its only librarian, Rulf Liutfievna Nurrulaeva. However, VNIITE evidently no longer has authority and prestige among Russian designers of various profiles.

- 
- 8 'Soviet Design 1950s–1980s', [www.moscowdesignmuseum.ru/en/exhibitions/1/](http://www.moscowdesignmuseum.ru/en/exhibitions/1/) (accessed 30 March 2015).
  - 9 'Dizain – massovoe proizvodstvo. A v Rossii proizvodstva net', Alena Lapina's interview with Aleksandra San'kova, *Bolshoi Gorod*, 28 November 2012, [http://bg.ru/entertainment/my\\_byli\\_po\\_odnu\\_storonu\\_barrikad\\_a\\_vstali\\_po\\_druguju-15852/](http://bg.ru/entertainment/my_byli_po_odnu_storonu_barrikad_a_vstali_po_druguju-15852/) (accessed 30 March 2015).
  - 10 This evaluation is most prominently proposed by Susan E. Reid, Margareta Tillberg and, from a younger generation, Tom Cubbin and researchers on design in the Baltic countries – Lolita Jablonskiene, Iliana Veinberga, Mari Laamanets and Andres Kurg. A number of scholars and curators similarly approach design in the European countries of the socialist bloc, most prominently David Crowley, who has researched and published extensively on design and popular culture in Poland, Czechoslovakia and Hungary; in 2008, with Jane Pavitt, he co-curated the exhibition 'Cold War Modern' at the Victoria and Albert Museum, London.
  - 11 Margareta Tillberg, 'Exhibition in Moscow, Soviet Design 1950s–1980s', *Baltic Worlds* 1 (2013), 28–9, <http://balticworlds.com/soviet-design-1950%E2%80%931980/> (accessed 30 March 2015).
  - 12 'Kachestvo – trebovanie dnia', *Sovetskaia torgovlia* 2 (1976), 63. Quoted in Oushakine, 'Against the "Cult of Things"'.
  - 13 These elements were presented as constitutive of a new type of object, anticipated in an editorial in the famous trilingual avant-garde journal *Veshch/Gegenstand/Objet* published by the artist (or, more properly, designer) Lazar' Lissitzky and the writer Ilya Ehrenburg in 1922 in Berlin. El Lissitzky and Ilya Ehrenburg, 'Blokada Rossii konchaetsia', *Veshch/Gegenstand/Objet* 1–2 (1922), 1–4.
  - 14 Tom Cubbin, 'Back to the Future: What the New Moscow Design Museum Can Learn from the Soviet Past', *The Calvert Journal*, <http://calvertjournal.com/comment/show/378/back-to-the-future-what-the-new-moscow-design-museum-can-learn-from-the-sov> (accessed 30 March 2014).

## Select bibliography

### Archival materials

*State Archive of the Russian Federation, main depository, Moscow (GARF)*

F. A-643 – Research Institute of Artistic Industry

*Russian State Archive of Economy, Moscow (RGAE)*

F. 7733 – USSR Ministry of Finance

*Russian State Archive of Cine-Photo Documents, Moscow (RGAKFD)*

Ed. khr. 18199 – Sergei Gurov, 'Dlia vashego doma' (Central Red Banner Studio of Documentary Films, 1962)

*Russian State Archive of Literature and Art, Moscow (RGALI)*

F. 2082 – Artists' Union of the USSR

F. 2460 – Moscow Higher School for Art and Industry (former Stroganov School)

F. 2466 – Moscow Branch of Architects' Union of the RSFSR

F. 2943 – Moscow Branch Artists' Union of the RSFSR

*Russian State Archive of Modern History, Moscow (RGANI)*

F. 5 – Central Committee of the Communist Party of the Soviet Union

*Russian State Archive of Scientific and Technical Documentation, Moscow (RGANTD)*

F. R – All-Union Research Institute of Technical Aesthetics

---

*Russian State Archive of Social and Political History, Moscow (RGASPI)*

F. 556 – Central Committee of the Communist Party, Department of Propaganda and Agitation for RSFSR

*Central State Archive, St Petersburg (TsGA SPb)*

F. 311 – Leningrad State Porcelain Factory named after M. V. Lomonosov

*Central State Archive of Cine-Phono-Photo Documents, St Petersburg (TsGAKFFD SPb)*

Ed. Khr. Ar- 94432 (Maldonado's visit to the Mukhina School)

*Central State Archive of Literature and Art, St Petersburg (TsGALI SPb)*

F. 78 – Leningrad Branch of the Artists' Union of the RSFSR

F. 266 – Leningrad Higher School for Art and Industry named after V. I. Mukhina

*Central State Archive of Scientific and Technical Documentation, St Petersburg (TsGANTD SPb)*

F. 146 – Leningrad Branch of the All-Union Research Institute of Technical Aesthetics

Soviet periodicals of the 1920s and 1950s–1970s

*Dekorativnoe Iskusstvo SSSR*

*Iskusstvo*

*Komsomol'skaia Pravda*

*LEF*

*Novyi mir*

*Pravda*

*Tekhnisheskaia Estetika*

Western periodicals of the 1960–1980s

*Design*

*Industrial Design*

Interviews

O. L. Nekrasova-Karateeva, 11 January 2010, 17 March 2014, 1 December 2017

M. A. Kos'kov, 16 January 2011

N. P. Malevskaia-Malevich, 18 March 2014

V. A. Tsivin, 26 March 2018



## Unpublished dissertations

- Bocharnikova, Daria. 'Inventing Socialist Modern: A History of Architectural Profession in the USSR, 1954–1971'. PhD dissertation, European University Institute, 2014.
- Gusarova, Julia Vasilievna. 'Leningradskaia keramika kak fenomen otechestvennoi kul'tury vtoroi poloviny XX veka'. PhD dissertation, Herzen State Pedagogical University of Russia, 2011.
- West, Diana Kurkovsky. 'CyberSovietica: Planning, Design and the Cybernetics of Soviet Space, 1954–1986'. PhD dissertation, Princeton University, 2013.

## Published secondary sources

- Akrich, Madeleine. 'The De-Description of Technical Objects'. In W. Bijker and J. Law, eds, *Shaping Technology/Building Society*. Cambridge, MA: MIT Press, 1992, pp. 205–24.
- Arvatov, Boris, and Christina Kiaer. 'Everyday Life and the Culture of the Thing (Toward the Formulation of the Question)'. *October* 81 (1997), 119.
- Attfield, Judy. *Wild Things: The Material Culture of Everyday Life*. Oxford: Berg, 2000.
- Azrikan, Dmitry. 'VNIITE, Dinosaur of Totalitarianism or Plato's Academy of Design?' *Design Issues* 15.3 (1999), 45–77.
- Bennett, Jane. *Vibrant Matter: A Political Ecology of Things*. Durham, NC: Duke University Press, 2010.
- Bourdieu, Pierre. *Distinction: A Social Critique of the Judgement of Taste*. London: Routledge, 1992.
- Boym, Svetlana. *Common Places: Mythologies of Everyday Life in Russia*. Cambridge, MA: Harvard University Press, 1994.
- Brown, Bill. 'Thing Theory'. *Critical Inquiry* 28.1 (2001), 1–22.
- Buchli, Victor. *An Archaeology of Socialism*. Oxford: Berg, 2000.
- Busbea, Larry. 'Metadesign: Object and Environment in France, C. 1970'. *Design Issues* 25.4 (2009), 103–19.
- Castillo, Greg. *Cold War on the Home Front: The Soft Power of Midcentury Design*. Minneapolis, MN: University of Minnesota Press, 2010.
- Chadaga, Julia Bekman. *Optical Play: Glass, Vision, and Spectacle in Russian Culture*. Evanston, IL: Northwestern University Press, 2014.
- Chernyshova, Natalya. *Soviet Consumer Culture in the Brezhnev Era*. New York: Routledge, 2013.
- Coole, Diana, and Samantha Frost. *New Materialisms: Ontology, Agency, and Politics*. Durham, NC: Duke University Press, 2010.
- Cowan, Ruth Schwartz. *More Work for Mother: The Ironies of Household Technology from the Open Hearth to the Microwave*. New York: Basic Books, 1983.
- Crowley, David, and Jane Pavitt, eds. *Cold War Modern: Design 1945–1970*. London: V&A Publishing, 2008.
- Cubbin, Tom. 'Postmodern Propaganda? Semiotics, Environment and the Historical Turn in Soviet Design 1972–1985'. *Journal of Design History*, 14 September 2016, epw028. doi: 10.1093/jdh/epw028.
- 'The Domestic Information Machine: Futurological Experiments in the Soviet Domestic Interior, 1968–76'. *Home Cultures* 11.1 (2014), 5–32. doi:10.2752/175174214X13807024691142.

- *Soviet Critical Design: Senezh Studio and the Communist Surround*. London: Bloomsbury, 2018.
- Daston, Lorraine J., ed. *Things That Talk: Object Lessons from Art and Science*. New York: Zone Books, 2007.
- Degot', Ekaterina. 'Ot tovara k tovarishchu: k estetike nerynochnogo predmeta'. *Logos* 26.5–6 (2000), 37, [www.ruthenia.ru/logos/number/50/14.pdf](http://www.ruthenia.ru/logos/number/50/14.pdf) (accessed 19 August 2019).
- Dmitrieva, Nina. *O prekrasnom*. Moscow: Iskustvo, 1960.
- Douglas, Mary. *Thought Styles: Critical Essays on Good Taste*. London: Sage, 1996.
- Dunham, Vera Sandomirsky. In *Stalin's Time: Middleclass Values in Soviet Fiction*. Enlarged edn. Durham, NC: Duke University Press, 1990.
- Fallan, Kjetil. 'Our Common Future. Joining Forces for Histories of Sustainable Design'. *Technoscienza* 5.2 (2015), 15–32.
- *Design History: Understanding Theory and Method*. New York: Bloomsbury, 2010.
- Fehérváry, Krisztina. *Politics in Color and Concrete: Socialist Materialities and the Middle Class in Hungary*. Bloomington, IN: Indiana University Press, 2013.
- Forty, Adrian. *Objects of Desire*. New York: Pantheon Books, 1986.
- Foucault, Michel. *The Order of Things: An Archaeology of the Human Sciences*. New York: Vintage, 1994.
- Gerasimova, Ekaterina, and Sof 'ia Chuikina. 'The Repair Society'. *Russian Studies in History* 48.1 (2009), 58–74. <https://doi.org/10.2753/RSH1061-1983480104>.
- Gille, Zsuzsa. *From the Cult of Waste to the Trash Heap of History: The Politics of Waste in Socialist and Postsocialist Hungary*. Bloomington, IN: Indiana University Press, 2007.
- Goldhagen, Sarah Williams, and Rejean Legault, eds. *Anxious Modernisms: Experimentation in Postwar Architectural Culture*. Cambridge, MA: MIT Press, 2001.
- Golomshtok, Igor. *Totalitarnoe iskusstvo*. Moscow: Gallart, 1994.
- Gough, Maria. *The Artist as Producer: Russian Constructivism in Revolution*. Berkeley, CA: University of California Press, 2005.
- Gronow, Jukka. *Caviar with Champagne: Common Luxury and the Ideals of the Good Life in Stalin's Russia*. Oxford: Berg, 2003.
- Groys, Boris. *The Total Art of Stalinism: Avant-garde, Aesthetic Dictatorship, and Beyond*. Princeton, NJ: Princeton University Press, 1992.
- Gurova, Ol'ga. 'The Life Span of Things in Soviet Society'. *Russian Social Science Review* 50.4 (2009), 49–60.
- Handley, Susannah. *Nylon: The Story of a Fashion Revolution. A Celebration of Design from Art Silk to Nylon and Thinking Fibres*. Baltimore, MD: Johns Hopkins University Press, 2000.
- Harris, Steven E. *Communism on Tomorrow Street: Mass Housing and Everyday Life after Stalin*. Washington, DC/Baltimore, MD: Woodrow Wilson Center Press/Johns Hopkins University Press, 2013.
- Hessler, Julie. *A Social History of Soviet Trade: Trade Policy, Retail Practices, and Consumption, 1917–1953*. Princeton, NJ: Princeton University Press, 2004.
- Ilic, Melanie, and Jeremy Smith, eds. *Soviet State and Society under Nikita Khrushchev*. London: Routledge, 2009.
- Izotova, Margarita and Mikhail Kopylkov. *Odna kompositsiia*. St Petersburg: Novaia Niva, 2011.

- Jones, Jeffrey W. *Everyday Life and The 'Reconstruction' of Soviet Russia during and after the Great Patriotic War, 1943–1948*. Bloomington, IN: Slavica Publishers, 2008.
- Jørgensen, Finn Arne. 'Green Citizenship at the Recycling Junction: Consumers and Infrastructures for the Recycling of Packaging in Twentieth-Century Norway'. *Contemporary European History* 22.3 (2013), 499–516. doi: 10.1017/S0960777313000258.
- Kelly, Catriona. *Children's World: Growing Up in Russia, 1890–1991*. New Haven, CT: Yale University Press, 2007.
- Khan-Magomedov, Selim O. *Pionery Sovetskogo Dizaina*. Moscow: Galart, 1995.
- Khelnianov, Sergei, and Svetlana Mirzoian, *Mukha: Sankt-Peterburgskaia Shkola Dizaina*. St Petersburg: Iunikont Design, 2011.
- Kiaer, Christina. *Imagine No Possessions: The Socialist Objects of Russian Constructivism*. Cambridge, MA: MIT Press, 2005.
- Kozlov, Denis, and Eleonory Gilburd. *The Thaw: Soviet Society and Culture during the 1950s and 1960s*. Toronto: University of Toronto Press, 2012.
- Kurg, Andres. 'The Prehistory of Contemporary Environment: Multimedia Program in the ICSID '75 Congress in Moscow'. In Anna Romanova et al., eds, *The Islands of Yuri Sobolev*. Moscow: The Moscow Museum of Modern Art, 2014, pp. 274–8.
- Lodder, Christina. *Russian Constructivism*. New Haven, CT: Yale University Press, 1985.
- Lovell, Stephen. *The Russian Reading Revolution: Print Culture in the Soviet and Post-Soviet Eras*. Basingstoke: Macmillan, 2000.
- Margolin, Victor. 'Expanding the Boundaries of Design: The Product Environment and the New User'. *Design Issues* 4.1/2 (1988), 59–64. <https://doi.org/10.2307/1511388>.
- Marx, Karl. *Writings of the Young Marx on Philosophy and Society*. Indianapolis, IN: Hackett Publishing, 1997.
- Miller, Daniel. *Material Culture and Mass Consumption*. Oxford: Blackwell, 1993.
- Moscow Design Museum, *Designed in the USSR: 1950–1989*. Berlin: Phaidon, 2018.
- Oldenziel, Ruth, and Heike Weber. 'Introduction: Reconsidering Recycling'. *Contemporary European History* 22.3 (2013), 347–70.
- Oldenziel, Ruth, and Karin Zachmann. *Cold War Kitchen: Americanization, Technology, and European Users*. Cambridge, MA: MIT Press, 2011.
- Oushakine, Serguei Alex. "'Against the Cult of Things": On Soviet Productivism, Storage Economy, and Commodities with No Destination'. *The Russian Review* 73.2 (2014), 198–236.
- Paperny, Vladimir. *Architecture in the Age of Stalin: Culture Two*. Cambridge: Cambridge University Press, 2011.
- Peavitt, Helen. *Refrigerator: The Story of Cool in the Kitchen*. London: Reaktion, 2017.
- Pfützner, Katharina. *Designing for Socialist Need: Industrial Design Practice in the German Democratic Republic*. London: Routledge, 2018.
- Raizman, David. *History of Modern Design: Graphics and Products since the Industrial Revolution*. London: Laurence King Publishing, 2003.
- Rancière, Jacques. *The Politics of Aesthetics: The Distribution of the Sensible*. London: Continuum, 2006.

- Randall, Amy E. *The Soviet Dream World of Retail Trade and Consumption in the 1930s*. Basingstoke: Palgrave Macmillan, 2008.
- Reid, Susan E. 'Khrushchev Modern: Agency and Modernization in the Soviet Home'. *Cahiers du Monde Russe* 47.1/2 (2006), 227–68.
- 'The Khrushchev Kitchen: Domesticating the Scientific-Technological Revolution'. *Journal of Contemporary History* 40.2 (2005), 289–316.
- Reid, Susan Emily, and David Crowley, eds. *Style and Socialism: Modernity and Material Culture in Post-War Eastern Europe*. Oxford: Berg, 2000.
- Roberts, Graham H., ed. *Material Culture in Russia and the USSR: Things, Values, Identities*. London: Bloomsbury, 2017.
- Rothschild, Joan, and Alethea Cheng. *Design and Feminism: Re-Visioning Spaces, Places, and Everyday Things*. New Brunswick, NJ: Rutgers University Press, 1999.
- Rubin, Eli. *Synthetic Socialism: Plastics and Dictatorship in the German Democratic Republic: Plastics and Dictatorship in the German Democratic Republic*. Chapel Hill, NC: UNC Press Books, 2009.
- Runge, V. F. *Istoriia Dizaina, Nauki i Tekhniki. Kniga Vtoraia*. Moscow: Arkhitektura-S, 2007.
- Serulus, Katarina. "'Well-Designed Relations': Cold War Design Exchanges between Brussels and Moscow in the Early 1970s". *Design and Culture* 9.2 (2017), 147–65 doi:10.1080/17547075.2017.1326231.
- Smith, Mark B. *Property of Communists: The Urban Housing Program from Stalin to Khrushchev*. DeKalb, IL: Northern Illinois University Press, 2010.
- St Pierre, Elizabeth A., Alecia Y. Jackson and Lisa A. Mazzei. 'New Empiricisms and New Materialisms: Conditions for New Inquiry'. *Cultural Studies ↔ Critical Methodologies* 16.2 (2016), 99–110. <https://doi.org/10.1177/1532708616638694>.
- Tillberg, Margareta. 'Made in the USSR: Design of Electronic/Electrical Systems in the Soviet Union from Khrushchev's Thaw to Gorbachev's Perestroika'. *Baltic Worlds* 3.2 (2010), 34–40.
- Varga-Harris, Christine. *Stories of House and Home: Soviet Apartment Life during the Khrushchev Years*. Ithaca, NY: Cornell University Press, 2015.
- Veenis, Milena. *Material Fantasies: Expectations of the Western Consumer World among the East Germans*. Amsterdam: Amsterdam University Press, 2012.
- Zubkova, E. IU. *Russia after the War: Hopes, Illusions, and Disappointments, 1945–1957*. Armonk, NY: M.E. Sharpe, 1998.
- Zubok, V. M. *Zhivago's Children: The Last Russian Intelligentsia*. Cambridge, MA: Belknap Press of Harvard University Press, 2011.

# Index

Note: page numbers in *italic* refer to illustrations.

Note: an 'n' after a page reference indicates the endnote number.

- abstraction 30–1, 34
- aesthetic regime of arts 16, 25–6, 36
- aesthetic turn 15–16, 25–6
- All-Union Research Institute of  
Technical Aesthetics *see* VNIITE
- American National Exhibition in  
Moscow 84, 127
- applied art 55–6, 95–6
  - definition of 8–9
  - theory of 29–30, 68–73
- architecture 29, 36–8, 50
- Art Fund 12, 14, 94, 108, 182, 184–7,  
193, 195
- Art Into Life exhibition 55, 69, 93–4,  
106, 114, 181
- artistic engineering 56, 74, 76
- Artists' Union of the USSR 6, 12,  
14–15, 28, 94, 105, 113, 140,  
159, 166–9, 172, 178, 180–5
- Arvatov, Boris 3–4, 36, 39, 49, 69, 104,  
139
  
- Baltic Soviet republics 52, 107,  
179–80, 184–5
- Banham, Reyner 111, 142
- Beskinskaia, Svetlana 169, 172,  
176
- Biakov, Iurii 110, 111, 112
- biography of an object 5, 69, 175
- Brezhnev era 102, 107, 153, 159–60,  
168, 182
- Bykov, Zakhar 39, 41–2, 44
  
- ceramics 18, 27, 176–7, 179–95
  - chamotte 106, 181, 189–91, plates  
13–16
  - image-ceramics 18, 183, 193
  - faience 49, 52, 106, 176, 185
  - porcelain 14, 24–5, 27, 55, 96, 106,  
111, 122–3, 187, plates 2, 10, 12
- Chekalov, Aleksandr 30–4, 71, 119
- class
  - hierarchies 48–9, 134
  - lower urban 109
  - middle 48–9, 134, 160
  - working 36
  - see also* proletarian culture/ society
- clocks 121–7, plates 7, 8
- Cold War 4, 16, 35, 84
- commodity fetishism 3, 51, 165
- communal flats 11, 49
- communism 76, 194
- composition-construction debate 49,  
51, 63n.117
- Constructivism 4, 29, 59n.51, 63 n.117,  
69, 70, 83, 96, 140
- consumer culture
  - Soviet/socialist 17, 49, 54, 95, 119,  
135, 143, 160, 168, 182, 187
  - Western/capitalist 4, 12, 16, 35, 75,  
134
- consumer demand 68, 79–80, 84, 86
- contemporaneity 16, 26, 35, 57
- CoID (Council of Industrial Design, UK)  
13, 75

- craftspeople 55, 160, 180, 194–5  
 glassblowers 109, 141, 170, 173  
 cybernetics 67, 89n.15, 104  
 Czechoslovakia 73, 180
- de-artefactualisation 120, 141–2, 202  
 decoration 8–9, 28–9, 34, 49–50, 71,  
 94–103, 106–9, 161, 165–6,  
 176–7  
 decorative-applied art 11  
 definition of 9  
 sections of 14, 30  
 decorative art 14, 17, 69, 95–6, 113,  
 159–69, 178–84, 193–4, 195  
 definition of 8–10  
 theory of 25–31, 105–8  
*Decorative Art of the USSR* (journal) *see*  
*Dekorativnoe Iskusstvo SSSR*  
 defamiliarisation (ostranenie) 109, 163  
*Dekorativnoe Iskusstvo SSSR* (journal)  
 12, 24–5, 47, 52–4, 65, 68, 71–4,  
 94, 100–7, 112, 138, 159–62,  
 168–79, 195, plate 1  
 Designers' Union of the USSR 14, 199  
 de-Stalinisation 12, 29  
 dissidents 107, 117n.80, 160  
 DIY 103, 144  
 Dzintari 185, 189
- Egerev, Viktor 37–8, 44–5  
 environmental approach to design  
 140–1, 153  
 ergonomics 32, 42, 82–3, 125, 136  
 Europe 145, 199  
 Eastern 74, 168  
 Western 54, 119, 128, 130, 168  
 evaluation  
 aesthetic 41, 70  
 expert (*expertiza*) 81–3
- folk art 5, 17, 28, 31–2, 48, 51–2, 99,  
 103, 107, 165–6, 173, 186  
 form-giving 7, 11, 137, 164, 174, 183,  
 190  
 France 43, 48  
 Vallauris 185, 197n.69  
 functionalism 51, 55–7, 59n.60, 84, 93,  
 103–4, 137, 140, 142, 201  
 furniture 31, 47, 49, 51, 55, 60n.71,  
 70–1, 199  
 collapsible 120, 150  
 imitation in refrigerators 134, 141–2  
 Finnish 39, 40, 44  
 kitchen 85, 130  
 modular 65–6, 96, 101, 122, 128  
 street 150  
 student projects 38–45  
 Swedish 39
- gender 64n.139, 79, 80, 84, 100, 134,  
 153–4n.2, 186, 190  
 Gerchuk, Iurii 62n.112, 71, 95, 106–7,  
 161, 163–4, 168  
 Germany  
 East 5, 54, 73  
 West 15, 122  
 glass  
 blown 99, 112, plates 4–6  
 lead 28, 97–8, 169–70, plate 3  
 Glazychev, Viacheslav 103–4, 115n.40  
 Gorodetskii, Vladimir 111, 187  
 graphic design 6, 75, 148–9, 200  
 Grushin, Boris 79, 90n.59
- honest object 50, 54–5, 57, 63n.117,  
 94–5, 105, 108, 110, 122, 181  
 human rights activists 71, 116–17n.80  
 hygiene 40, 82, 86, 109, 130, 134
- Iaglova, Nina 1, 7, 29, 31, 70, 99  
 Ianovskaia, Ekaterina 98, 170, plate 3  
 ICSID (International Council of the  
 Societies Industrial Design) 14,  
 75, 118  
 image-ceramics *see* izokeramika  
 industrial design 9, 13, 15–17, 57,  
 60n.71, 68, 72–3, 103, 110, 113,  
 140, 166, 169  
 industrial designers 6, 60n.71, 105,  
 118–19, 194  
 intelligentsia 50, 140, 160, 186, 191,  
 195  
 interior design 75, 184  
 internationalism 17, 107, 114  
 Italy 57n.2, 112, 142, 171, 197n.69, 202  
 Faenza 185, 197n.69  
 izokeramika 183–4, 194  
 Izotova, Margarita 182–5, 189, 191
- Kagan, Moisei 29–30, 53, 54, 68, 85  
 Kantor, Karl 71, 78, 119–20, 140–2  
 Kapelian, Grigorii 110, 187–8, 191  
 Khrushchev, Nikita 12, 14, 16–17,  
 28–9, 37, 49, 60n.61, 66–7,  
 84–5, 99, 104, 114, 185  
 Khrushchev era 5, 16, 39, 45, 93,  
 95–6, 102, 106, 113, 141, 165–6,  
 181, 193

- Khrushchev, Nikita (*cont.*)  
 Khrushchev Modern 5, 26, 35  
 Thaw 14, 28, 32, 95, 156n.67  
 kitchen 40–1, 84–6, 88, 121, 123,  
 127–8, 130, 135  
 debate 12, 84  
 clocks 123, 127  
 ware 55, 56, 68, 84–7, 178  
 Komsomol 36–7, 43–4, 79  
*Komsomol'skaia Pravda* (newspaper)  
 49, 79, 90n.59  
 Kopylov, Mikhail 181, 183–6, 189–90,  
 193, plates 13–16  
 Kosygin reforms 67, 78, 143, 168,  
 170  
 Kramarenko, Liudmila 111–12, 161  
 Kushner, Boris 120, 139, 154n.11
- Ladur, Mikhail 94, 102–3, 105  
 late socialism 4, 15, 26, 34, 68, 88,  
 160, 175, 179, 191, 199, 202  
 leisure 8, 14, 17, 37, 43, 100  
 Leningrad Factory of Artistic Glass 96,  
 97–8, 111, 169–71, 173, 191,  
 plates 3, 6  
 Leningrad Porcelain Factory *see*  
 porcelain  
 Leporskaia, Anna 123, 187, 189, plate  
 10  
 LOSKh/LSSKh Leningrad branch of the  
 Artists' Union of the RSFSR 11,  
 183–4, 186, 193  
 LVKhPU *see* Mukhina School
- Makarov, Kirill 108, 110, 112, 161,  
 165–7, 189, 191  
 Malevich, Kazimir 170, 185, 189  
 Markov, Vladimir 185–6  
 Marxism 48, 107, 144  
 mass housing 11, 35, 38, 40, 49, 50,  
 66, 73, 78, 85, 88, 105  
 material installation *see* Kushner, Boris  
 Matsa, Ivan 68–72  
 Mayakovsky, Vladimir 121  
 Medvedev, Vsevolod 84–7  
 metalwork 40, 60n.64–5, 60n.71, 105,  
 122, 160  
 modernism 34–5, 38, 69, 106, 140,  
 160, 182  
 Soviet/socialist modernism 5, 26, 34,  
 45, 56, 141, 181  
 Moscow Art and Industry School  
 (former Stroganov) 11  
*see also* MVKhPU
- MOSKh Moscow Branch of the Artists'  
 Union of the RSFSR 11  
 Mukhina school 11, 27, 51, 122, 184,  
 186, 193, 198n.80  
 Mukhina, Vera 191  
 MVKhPU 38–40, 43–4, 60n.71, 73
- Nekrasova-Karateeva, Olga 181, 186,  
 189, 193, plates 13, 16  
 neodecorativism 95, 106–14, 118, 134,  
 141, 159, 165, 169, 180  
 Nevler, Leonid 100–2  
 New Economic Policy (NEP) 4, 48  
 new materialism 1, 4, 66–7  
 Novikov, Feliks 37
- obsolescence 35–6, 109  
 One Composition (OK) 18, 160, 183–95  
 ornament 8–9, 11, 27–8, 31, 34, 48,  
 50–3, 55, 70, 72, 96, 98–9, 107,  
 165
- painting  
 ceramics 31, 106, 175, 189, plate 2  
 decorative 24, plate 1  
 easel 8, 10–11, 25, 28, 30–1, 47, 69,  
 93, 109, 163, 165, 194  
 peasant arts/crafts 8–9, 51–2, 55, 109  
 Pereverzev, Leonid 140–1, 153, 174  
 perestroika 18, 26, 48, 153, 199, 200  
 Pioneer Palaces 36–7, 39, 43–6, 85  
 planned economy 5, 8, 75, 88, 120,  
 140, 144–5, 163, 187  
 plastic (material) 35, 40, 44, 53–4,  
 60n.71, 86, 107, 122, 137, 151,  
 189  
 plywood 41, 44, 183  
 Poland 73, 120, 203n.10  
 Pop-art 35, 189, 190  
 postmodernism 17, 104, 112, 134, 142  
 pottery 52, 62n.119, 183, 187  
 prefabricated flats 49, 55, 85, 87, 107,  
 109, 120, 128, 179  
 productivism 3–4, 9, 12, 36, 39, 51, 56,  
 69, 88, 119, 137, 141, 143, 169,  
 179, 193  
 proletarian culture/society 36, 48–9,  
 69
- recycling 2, 144–51, 153  
 refrigerator 127–34  
 Rezin, Vladimir 129, 130, 131–3  
 Riabushin, Aleksandr 78, 119–20, 123,  
 139–42

- Rodchenko, Aleksandr 3, 39, 43, 49, 63n.117
- Rozenblium, Evgenii 72, 75, 120, 140, 164–6
- Russian avant-garde 3–4, 6, 8, 10, 12, 26, 38, 58n.36, 69, 74, 139, 149–50, 171, 202
- Saltykov, Aleksandr 9, 28–9, 50–2, 94, 105
- Second World War 10, 14, 49, 51, 66, 121, 129, 146
- semiotics 41, 68, 105, 110, 200
- Senezh studio 6, 140, 164, 166–7
- Smirnov, Boris 51–5, 96–9, 109–18, 161–3, 169–73, 185, 187, plates 4–6
- Artist on the Nature of Things* 118–19
- socialist realism 25–30, 56–7
- Soloviev, Iurii 11–14, 72, 75, 119, 143, 200–1
- Stalinism 14, 29
- Stepanian, Nonna 106, 111, 161
- Stepanova, Varvara 3, 39, 63n.117
- studio ceramics 180, 185, 194, 197n.69
- supergraphics 150–1
- Surrealism 36, 59n.51
- sustainability 2, 143
- taste 46–57, 61–2n.97, 64n.139, 79, 81, 94–5, 100–9
- Tatlin, Vladimir 33, 39
- technical aesthetics 67, 73–81, 93, 123
- Tekhnicheskaiia Estetika* (journal) 13, 47, 75–6
- textile 14, 24, 30, 34–5
- thing theory 1, 35, 163
- transport design 10–11, 38, 149
- Tretiakov, Sergei *see* biography of an object
- Tsivin, Vladimir 186–7, 189–94, plate 15
- Tucny, Petr 73–4
- Ulm School of Design 15, 17, 139
- user-friendliness 9, 42, 76, 83, 125, 129, 136
- vacuum cleaner 17, 35, 66, 76, 82, 134–8, 156n.67, plate 11
- Vaks, Iosif 10
- Vasil'kovskii, Vladimir 186
- vibrancy 30–4, 65, 189
- Vilnius 13, 87, 179–80, 183
- Vkhutein 21n.47, 34
- Vkhutemas 21n.47, 39, 41–2
- VNIITE
- history 13–17
- Leningrad branch (LF) 77, 83, 86, 129, 138
- methodological guidelines 68, 74–83
- product design 83–8, 119–39
- Voronov, Nikita 52, 170, 178–9
- wood 39–42, 71, 122
- imitation of 130–2
- Zhadova, Larisa 73–4







1 Double page spread in the journal *Dekorativnoe Iskusstvo SSSR* 10 (1967), 40–1. Left: M. Primachenko, decorative painting, Bolotnia, Kiev oblast, 1965. Right: Mikhail Posokhin et al., COMECON building at Novyi Arbat in Moscow, 1967.



2 Teapots 'Tundra', USSR, porcelain, overglaze painting and gilding, 1959.



3 Ekaterina Ivanovskaia, set of bottles and glasses, 'Rainbow', coloured and colourless lead glass, incising, 1964-72.



4 Boris Smirnov, decorative sculpture, 'Tea Couple', coloured ground and transparent non-lead glass, blown with hot applications, 1966.



**5** Boris Smirnov, composition, 'Festive Table', fragment, coloured and colourless transparent non-lead glass, coloured ground non-lead glass, blown with hot applications, 1967.



6 Boris Smirnov, sculpture, 'Man, Horse, Dog and Bird', colourless transparent non-lead glass, coloured ground and polished non-lead glass, blown with hot applications, before 1970.

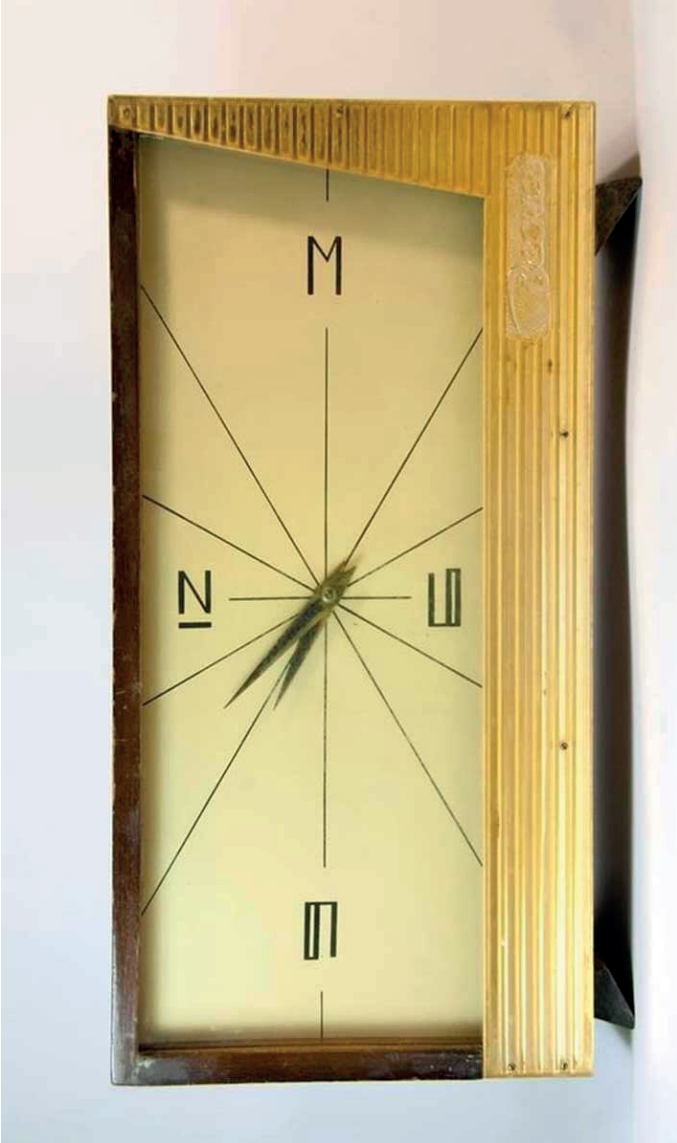

7 Table clock with chime, Vesna, 1963.





8 Wall clock, 'lantar', 1965.



9 Radio receiver, Moskvich, 1963.



**10** Vase, 'Narcissus', porcelain, colour monochrome glaze, shape by Anna Leporskaia, 1962.



11 Buran vacuum cleaner, 1968.



12 Teapot, USSR, porcelain, 1970s.



13 Olga Nekrasova-Karateeva, 'Calla Lilies', chamotte, salts, glazes, 1976.



14 Mikhail Kopylkov, 'Pink Dress and Autumn Coat', chamotte, salts, glazes, metal, 1976.

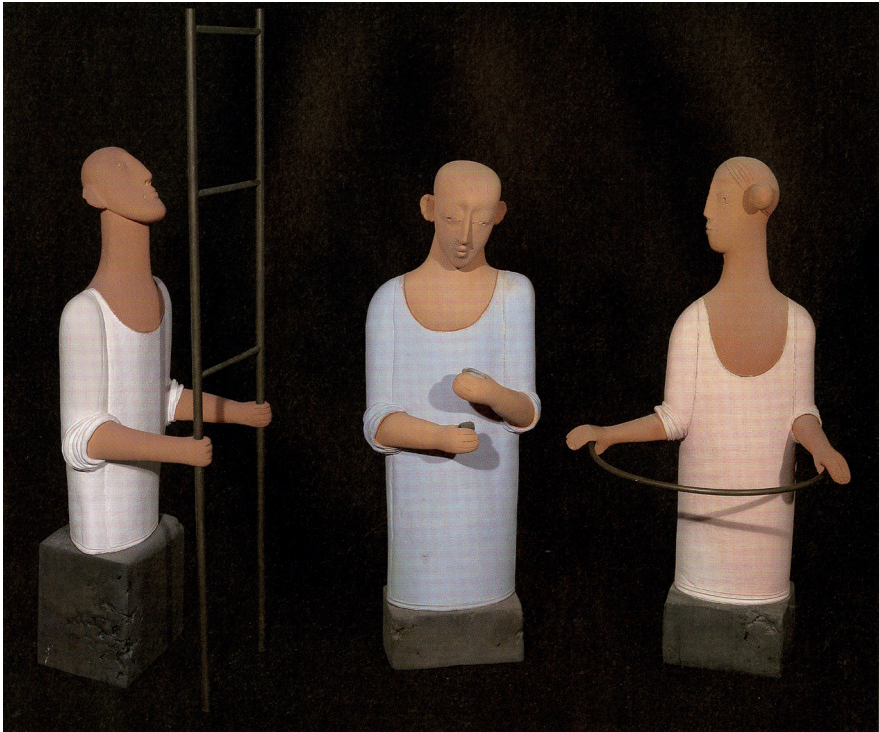

15 Vladimir Tsivin, 'People and Objects', chamotte, engobe, glaze, metal, glass, 1980.



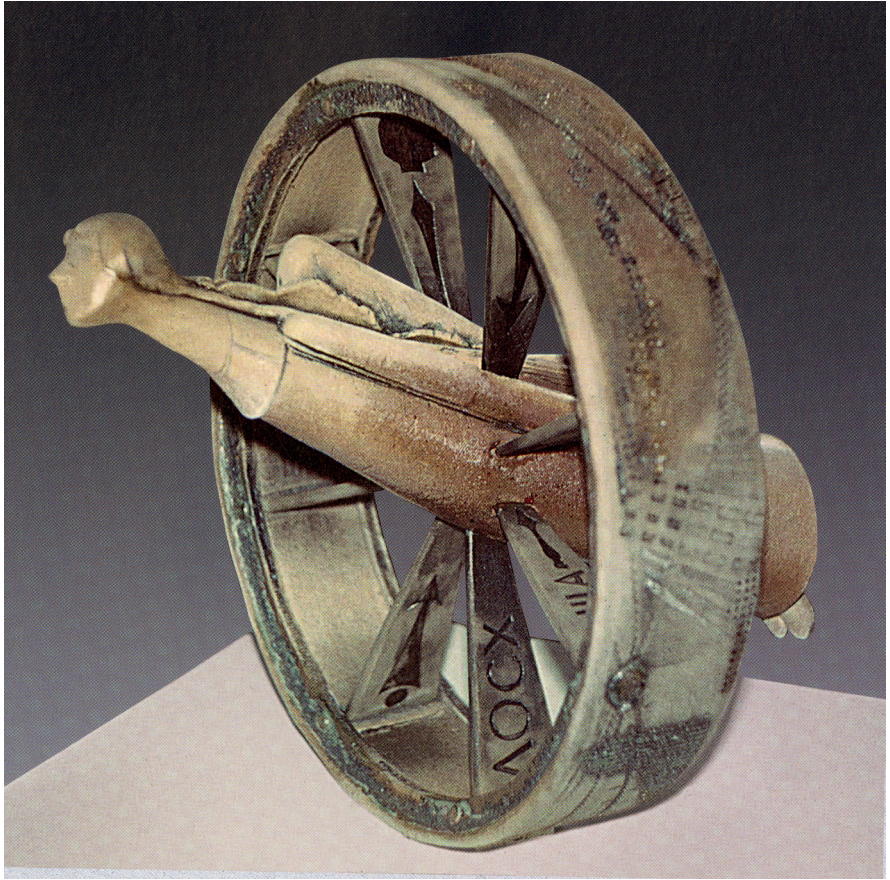

16 Olga Nekrasova-Karateeva, 'Self-Portrait', chamotte, enamels, glazes; potter A. Sokolov, 1984.