

We are IntechOpen, the world's leading publisher of Open Access books Built by scientists, for scientists

5,300

Open access books available

130,000

International authors and editors

155M

Downloads

Our authors are among the

154

Countries delivered to

TOP 1%

most cited scientists

12.2%

Contributors from top 500 universities



WEB OF SCIENCE™

Selection of our books indexed in the Book Citation Index
in Web of Science™ Core Collection (BKCI)

Interested in publishing with us?
Contact book.department@intechopen.com

Numbers displayed above are based on latest data collected.
For more information visit www.intechopen.com



Antennas for Space Applications: A Review

Volkan Akan and Erdem Yazgan

Abstract

It is well known that antennas are inevitable for wireless communication systems. After the launch of Sputnik-1 which was the first artificial satellite developed by USSR (Union of Soviet Socialist Republics), telecommunication technologies started to develop for space excessively. However, significance of the antennas as first or final RF-front end element has not been altered for the space communication systems. In this chapter, after introducing telecommunication and antenna technologies for space, which space environmental conditions are to be faced by these antennas are summarized. Then, frequency allocation that is a crucial design factor for antennas is explained and tabulated. And finally at the last part, different types of antennas used in different space missions are presented with their functional parameters and tasks.

Keywords: space, antenna, communication, satellite, spacecraft

1. Introduction

With the II World War, especially radar and military communication technologies gained thoughtful importance, and studies on antenna design, analysis and measurement caught a great momentum. Particularly, low volume antennas were needed for installation in air and naval combat vehicles. By the development of digital computers aftermath of the war, antenna design and analysis began to be carried to the computer environment to realize analytical and computational electromagnetic techniques. This era accelerated development process of antennas like other communication elements.

Nowadays, studies on microwave integrated circuits and components, which are frequently used in communication systems designed to operate at high frequencies, are going ahead at a dizzying pace. In addition, theoretical and experimental studies focusing on solid-state devices and planar transmission lines have greatly contributed to the development of microwave integrated circuits and components and expanded their use. In the light of these developments, interest to antennas, particularly for planar ones, has increased and thus, in order to reduce the cost and also volume occupied by microwave and RF systems, printed antennas are generally preferred to use them with high frequency circuits in the same plane.

As is well known, the space race of humankind started with the first artificial satellite *Sputnik-1* which was developed and placed into orbit by the USSR in 1957. A model of Sputnik-1 is shown in **Figure 1**. In the same year, *Sputnik-2* placed a living being into orbit of Earth for the first time. In the following year, the USA

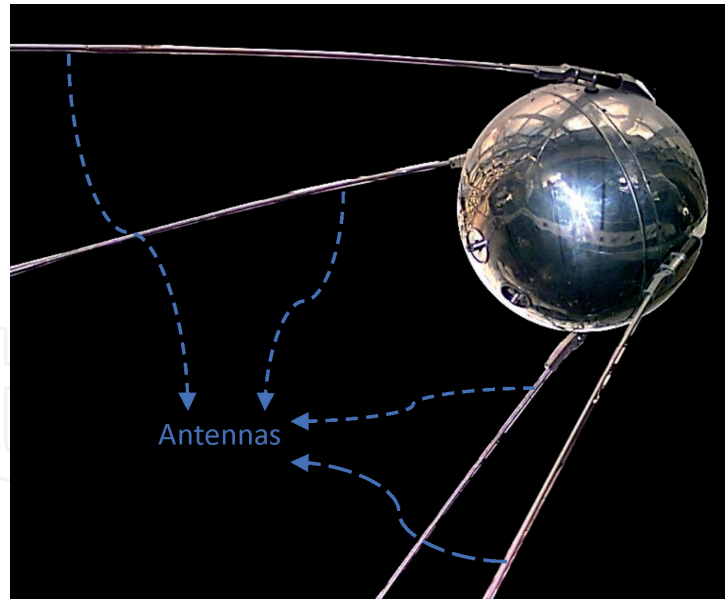

Figure 1.
The Sputnik-1 with monopole antennas (image courtesy of NASA/NSSDCA).

joined this race with *Explorer-1*. The Explorer-1 was placed into an orbit with a perigee of 360 km and apogee of 2535 km as mentioned in [1]. It had a cosmic ray sensor, an internal temperature sensor, a temperature sensor on the cone nose, and a microphone to detect the micro-meteoroid effect. Its most important task was to detect high-energy atomic particles with a cosmic ray sensor. The sensor therefore contained a Geiger-Müller tube. There were two transmitters at 108 and 108.03 MHz. It transmitted the relevant data to the station with those modules. As can be seen from **Figure 2**, the fiberglass slot antenna is positioned toward the nose of the vehicle. In addition, four flexible monopoles are placed in the middle of the vehicle. Its most important achievement was the discovery of the generations of Van Allen belt around the world. Afterward, this discovery was confirmed by Explorer-3 spacecraft [1].

By 2017, there were 4635 satellites orbiting the planet for different purposes based on the published Index of Objects Launched into Outer Space maintained

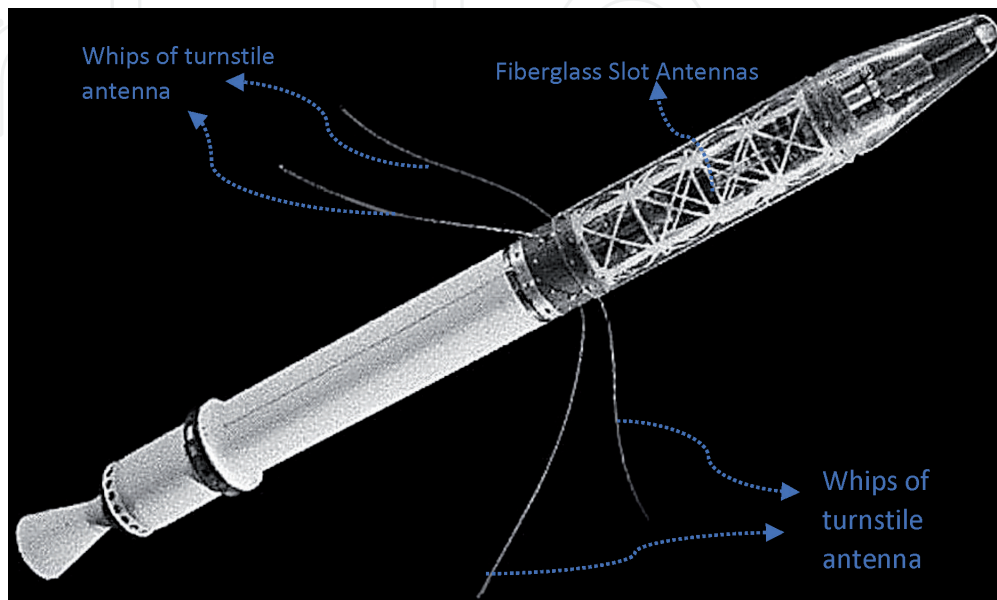

Figure 2.
The Explorer-1 with its turnstile antenna for VHF communication (image courtesy of NASA).

by the United Nations Office for Outer Space Affairs (UNOOSA). According to the report of 2019, while this chapter was being written, about 5000 satellites have been evolving around the world.

In recent years, especially antennas used in satellite communication systems are expected to have low volume, lightweight, low cost, high gain and directivity. Since the antennas used here are the last elements of the transmitting and receiving systems, they enable the connection of both sides over the space. They must be therefore suitable to the structure on which they are used, both electrically and physically. In addition, the gain and radiation pattern characteristics must be considered together with the general approaches used in the design of these antennas. The characteristics of the printed circuit antennas in meeting these criteria are more appropriate. Another important feature is that it is compatible with printed circuit technology and can be produced as a persistence of RF and high frequency circuit topology. Another advantage of printed circuit antennas is that they can be easily mounted on non-planar surfaces or manufactured using flexible printed circuit boards. In order to realize matching circuits, in very small areas inductive, resistive and capacitive surface mount device (SMD) components can be used with the printed circuit technology. Similarly, the frequency tuning of the antennas can be achieved electrically and mechanically in a variety of ways, which makes it particularly advantageous for the printed circuit antennas.

Depending on the orbit around the world in general, space vehicles and satellites can be divided into six main groups:

- Satellites with low earth orbiting (LEO) satellites
- Satellites with middle earth orbiting (MEO) satellites
- High elliptical orbiting (HEO) satellites
- Geostationary (GEO) satellites,
- Scientific research and exploring for solar system, deep space and others,
- Manned space flights-for now generally in LEO for example International Space Station (ISS).
- In addition, space launch vehicles can be added to this list.

There are also telemetry/telecommand (TM/TC) communication units in different frequency bands, global positioning systems and other telecommunication modules for transmitting and receiving the RF signals in launch vehicle, respectively. Consequently, suitable antennas should be designed and utilized according to planned mission for the space launch vehicles similar to the satellites.

One of the most needed satellites is LEO satellite. LEO satellites orbit between 160 and 1600 km from the Earth's surface. These satellites are usually small compared to communication GEO satellites, easy to launch and put into orbit. They can be used for different purposes. For ground monitoring purposes, satellite constellation can be placed into orbit and used for voice, fax and data communications. In addition, due to the limited surface area and volume available on the satellite, the antenna must be as small as possible in weight and volume. Finally, considering the limited power budget of the satellite, it is important that the antenna may have a passive and conical radiation pattern to direct the electromagnetic energy to low elevation angles.

Antennas used in LEO-type satellites can be divided into three types: payload data transmission (PDT) antennas for downloading high-density data to the ground station or inter satellite link (ISL) communication, payload antennas for special missions like mobile communication, GNSS services or remote sensing operations and TM/TC antennas to control the satellite and receive health parameters to monitor its functionality. The frequency ranges allocated for LEO satellites vary according to the characteristics of the payload on the satellite, but are determined by International Telecommunication Union (ITU).

After a LEO satellite is launched, it must be brought to desired position or orbit in order to fulfill the function of the satellite or be required to stabilize tumbling. This phase is called as Launch and Early Orbiting Phase (LEOP). In this case, hemispherical or omnidirectional antennas are very beneficial and used for the transmitting and receiving TM/TCs since they have wide coverage capability [2]. Antennas having directional or shaped conical radiation pattern are preferred in order to transmit telemetry and payload data to the ground station after it has been commissioned. Since line of sight (LOS) communication time interval is limited over one ground station, it is desirable to use this interval in the most efficient manner. This can be acquired by starting downlink and uplink communication at low elevation angles of the satellite. Because it will provide more time to download high-density payload data from the satellite. Therefore, at lower elevation angles of the satellite, a higher antenna gain is required, whereas in the case where the satellite is at higher elevation angle with respect to ground station, the antenna gain may be relatively lower so as to maintain link margin positively.

2. Antennas exposed to effects of space environment

In space not only functionality should be taken into consideration but also durability and reliability of antennas should be taken into account. Consequently, in design phase of antennas to be used in space applications, environmental conditions are decisive factors. Materials to be used on space antennas should meet requirements based on space qualifications and factors [3]. These factors can be listed under two main subjects: *effects due to the launching activity* and *space environment*.

2.1 Launch phase

During launch of spacecraft, acoustic vibrations, shocks, mechanical stress based on static loads, dynamic loads and sudden atmospheric pressure fall occur and those effects should be taken into account in the course of antenna design step. In addition, in commissioning phase pyrotechnical shocks are generated while deploying solar panels and payloads like deployable antennas. All of those may affect objects, for example antennas, detached to surface of spacecraft, adversely.

2.2 Space environment

After LEOP, antennas will be exposed to harsh space environment. Those can be listed as vacuum, high temperature changes regarding nonconductive thermal feature of vacuum typically between -150 and 150°C , outgassing or material sublimation which can create contamination for payloads especially on lens of cameras, ionizing or cosmic radiation (beta, gamma, and X-rays), solar radiation, atomic oxygen oxidation or erosion due to atmospheric effect of low earth orbiting.

2.3 Verification for launch and environmental effects

In order to verify that antennas can perform functionally in space environment and withstand launch effect mentioned above, some tests should be performed as addition to functional tests before mission started. These environmental verifications can be listed as:

- thermal qualification,
- sine vibration,
- random vibration or acoustic,
- quasi-static acceleration,
- stiffness measurement, and
- low outgassing compatibility [4].

To verify the modules, requirements and tests have been defined by NASA and ESA in their published standards. For space programs, the related requirements and tests are prepared based on those standards. Some important and general ones can be listed as:

- ECSS-E-ST-32-08C—materials
- ECSS-Q-ST-70-02—thermal vacuum outgassing test for the screening of space materials
- ECSS-Q-ST-70-71C Rev.1—materials, processes and their data selection
- ECSS-E-ST-10-03C—testing
- ECSS-Q-ST-70-04C—thermal testing for the evaluation of space materials, processes, mechanical parts and assemblies

which have been published by ESA and

- GSFC-STD-7000A—General Environmental Verification Standard (GEVS) for GSFC Flight Programs and Projects
- Outgassing Data for Selecting Spacecraft Materials
- NASA-STD-7002B—Payload Test Requirements
- NASA-STD-5001—Structural Design and Test Factors of Safety for Spaceflight Hardware
- NASA-STD-7001—Payload Vibroacoustic Test Criteria
- NASA-STD-7003—Pyroshock Test Criteria

which have been published by NASA.

2.4 Other effects

2.4.1 Multipaction and corona discharge

Multipaction is, basically, an event that can be reason of breakdown because of high power RF signal in a vacuum or near vacuum medium. It can reduce RF output power of device, cause noise in RF signal and even *corona discharge* because of ionization in presence of electromagnetic wave. Therefore, it can result a catastrophic failure of an antenna, RF component and even another payload module. There are two main factors for multipaction: high RF power and vacuum medium. Thus, related RF components including antennas should be either analyzed or tested for these phenomena. There is an analysis tool designed by ESA/ESTEC named as “ECSS Multipactor Tool”. By using this tool one can calculate threshold and safety margin levels for pre-defined structures according to the operating frequency, impedance, RF power level, material finishing and minimum distance between metal tips or edges.

2.4.2 Passive intermodulation

As is known, in active RF devices there can occur intermodulation products of applied two or more tones at the output of the device. Similar phenomenon can be seen at antennas because of two main reasons: nonlinearity of material and nonlinearity of contact.

To avoid multipaction and passive intermodulation there are some published standards for design and verification phases. One of them is ECSS-E-20-01A Rev.1—*multipaction design and test*.

3. Frequency allocations for space missions

Radio frequency spectrum usage must be regulated to guarantee a cost-effective and high-capacity utilization for terrestrial and satellite communication systems all over the world. Although, the frequency intervals used for the spacecrafts vary according to the characteristics of the TM/TC modules and payload on the space vehicle, they are determined and coordinated by International Telecommunication Union (ITU). ITU, which is a United Nations structure, acts under the contract accepted by the executives of member states. For this aim, ITU holds a forum and owing to this forum it can do coordination of radiofrequency spectrum, define standards for communication protocols, device or equipment characteristics and interference levels between private sector and member states [5].

There are radio communication services defined for space applications to transmit or receive radio signals by the Radio Communication Regulations. Those are

- ASS: amateur satellite service
- BSS: broadcasting satellite service
- EES: Earth exploration satellite service
- FSS: fixed satellite service
- ISS: inter-satellite service

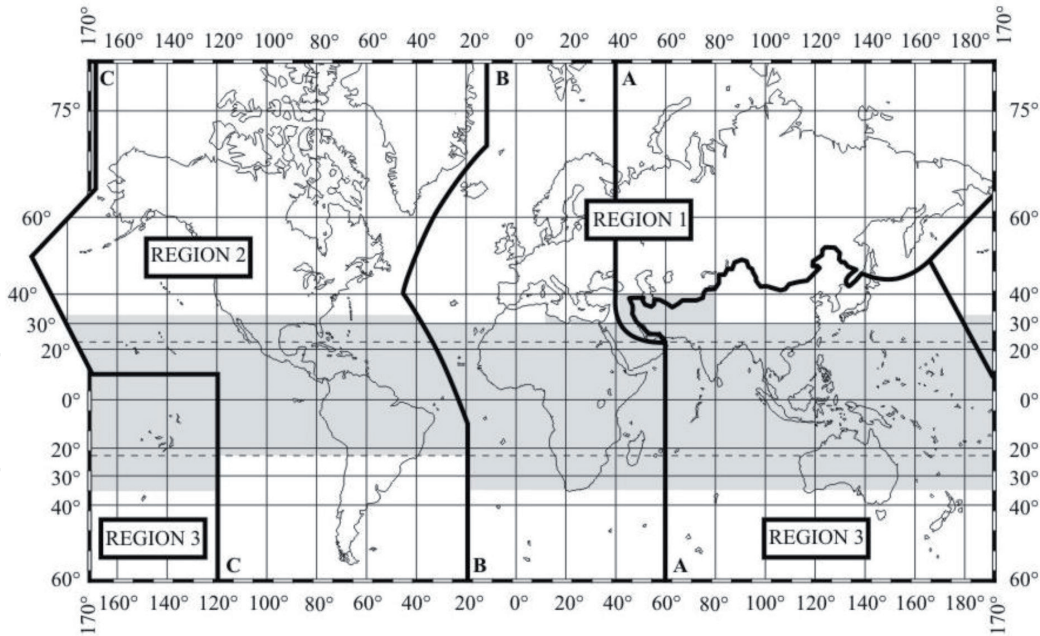

Figure 3. ITU regions of the world for frequency allocation as given in [6] (image courtesy of ITU, source: ITU radio regulations (2016 edition)).

- MSS: mobile satellite service
- RSS: radio determination satellite service
- SOS: space operation service
- SRS: space research service

Based on the radio communication services mentioned above, the defined or allocated frequency bands can be private for one of them or shared between these services. Moreover, the world has been divided into three parts for the coordination as accepted and published in 1988. It is seen in **Figure 3**.

Region 1 consists of Europe, Africa, the Middle East and the land of former USSR; Region 2 is the Americas and finally region 3 is Asia Pacific but not including the Middle East and land of former USSR. In **Table 1**, some specific frequency bands used for space communication are presented. An interested reader to see full frequency spectrum allocations of terrestrial and space application can visit the web site created by IEEE Geoscience and Remote Sensing Society given in [7].

4. Antenna types used on spacecrafts

There are many different spacecrafts to conduct various missions for humankind. Consequently, they need different subsystems like communication subsystems, microwave imaging payloads, instrument landing systems which use radar technology, scientific and experimental research devices to explore deep-space and many others. This leads to a need for different type of antennas to fulfill defined missions successfully. Spacecrafts can be divided into four main groups: missile launchers, satellites, radio astronomy and deep space vehicles. Based on this categorization some antenna types used on those vehicles will be reviewed in the following sections.

Frequency band (MHz)	Primary allocation	European common allocation	Applications	Standard
144–146	Amateur Amateur satellite 5.216	Amateur Amateur satellite	Amateur Amateur satellite	EN 301 783
434.79–438	Amateur Radiolocation Earth exploration-satellite (active) 5.279A 5.138 5.271 5.276 5.277 5.280 5.282	Amateur Amateur satellite Radiolocation Earth exploration satellite (active) 5.279A 5.277 EU2 EU12	Active sensors (satellite) Amateur Amateur satellite	EN 301 783
1164–1215	Aeronautical radio navigation 5.328 Radio navigation satellite (space-to-Earth) (space-to-space) 5.328B 5.328A	Aeronautical radio navigation 5.328 Radio navigation-satellite (space-to-Earth) (space-to-space) 5.328B 5.328A	Aeronautical navigation GALILEO GLONASS GNSS repeater	EN 302 645
1215–1240	Earth exploration satellite (active) Radiolocation Radio navigation satellite (space-to-Earth) (space-to-space) 5.328B 5.329 5.329A Space research (active) 5.330 5.331 5.332	Earth exploration satellite (active) Radiolocation Radio navigation satellite (space-to-Earth) (space-to-space) 5.328b 5.329 5.329a Space research (active) 5.331 EU2 5.332	Active sensors (satellite) Defense systems GLONASS GNSS repeater GPS Radiolocation (civil)	EN 302 645
1559–1610	Aeronautical radio navigation Radio navigation satellite (space-to-Earth) (space-to-space) 5.208B 5.328B 5.329A 5.341 5.362B 5.362C	Aeronautical radio navigation Radio navigation satellite (space-to-Earth) (space-to-space) 5.208B 5.328B 5.329A 5.341 5.362B	GALILEO GLONASS GNSS pseudolites GNSS repeater GPS	EN 302 645
2025–2110	Earth exploration satellite (Earth-to-space) (space-to-space) Fixed Mobile 5.391 Space operation (Earth-to-space) (space-to-space) Space research (Earth-to-space) (space-to-space) 5.392 5.392	Earth exploration satellite (Earth-to-space) (space-to-space) Fixed Mobile 5.391 Space operation (Earth-to-space) (space-to-space) Space research (Earth-to-space) (space-to-space) 5.392 EU2 EU15 EU27	Defense systems Fixed PMSE Space research	EN 302 217 EN 302 064

Frequency band (MHz)	Primary allocation	European common allocation	Applications	Standard
2200–2290	Earth exploration satellite (space-to-Earth) (space-to-space) Fixed Mobile 5.391 Space operation (space-to-Earth) (space-to-space) Space research (space-to-Earth) (space-to-space) 5.392	Earth exploration satellite (space-to-Earth) (space-to-space) Fixed Mobile 5.391 Space operation (space-to-Earth) (space-to-space) Space research (space-to-Earth) (space-to-space) 5.392 EU15 EU27	Defense systems Fixed PMSE Radio astronomy Space research	EN 302 217 EN 302 064
8025–8400	Earth exploration satellite (space-to-Earth) Fixed Fixed satellite (Earth-to-space) Mobile 5.463 5.462A	Earth exploration satellite (space-to-Earth) Fixed Fixed satellite (Earth-to-space) Meteorological satellite (Earth-to-space) Mobile 5.463 5.462A EU2 EU27	Defense systems Earth exploration satellite Fixed Radio astronomy Radio determination applications	EN 302 217 EN 302 729

Table 1.
 Some specific frequency bands for space communication defined by ITU.

4.1 Antennas for missile launchers

In order to acquire TM/TC communication, guidance, transmitting and receiving radar signals, sending video and image, communicating with satellite after departing, there are many antennas used on missile launchers. Up to now, a lot of different antenna types have been designed for this purpose. However, since the main objective of missile is military usage (ballistic missiles a good example), it is hard to find adequate info about subsystems on them in open literature. In the following subsections some examples are given.

4.1.1 Transmission line antennas

Particularly for TM/TC communication subsystems, missiles need Omnidirectional antennas to communicate with ground stations. Since antennas are the final or first component of RF transmitter or receiver, respectively, they must be on outward or just underneath surface of missiles with RF transparent radome. Nevertheless, they must comply with aerodynamic structure of missile. Otherwise, it will increase air-drag during trip along the atmosphere. Therefore, if antennas will be used over the surface of a missile, they must be compatible with aerodynamic structure. A well-known type of antenna for this goal is *transmission line antenna* [8] which is also commonly used for other aerospace vehicles. It is known that radiation resistance of a transmission line is quite small. In order to increase the radiated power rather than power dissipated as heat, a transmission line can be terminated with reactive elements like capacitors, conducting bridges or open ends. Based on this technique, in [8] four types of them have been presented. These are *inverted L antenna*, *shunt-driven inverted L antenna with open end*, *shunt-driven inverted L antenna with capacitive end loading* and finally *m antenna*.

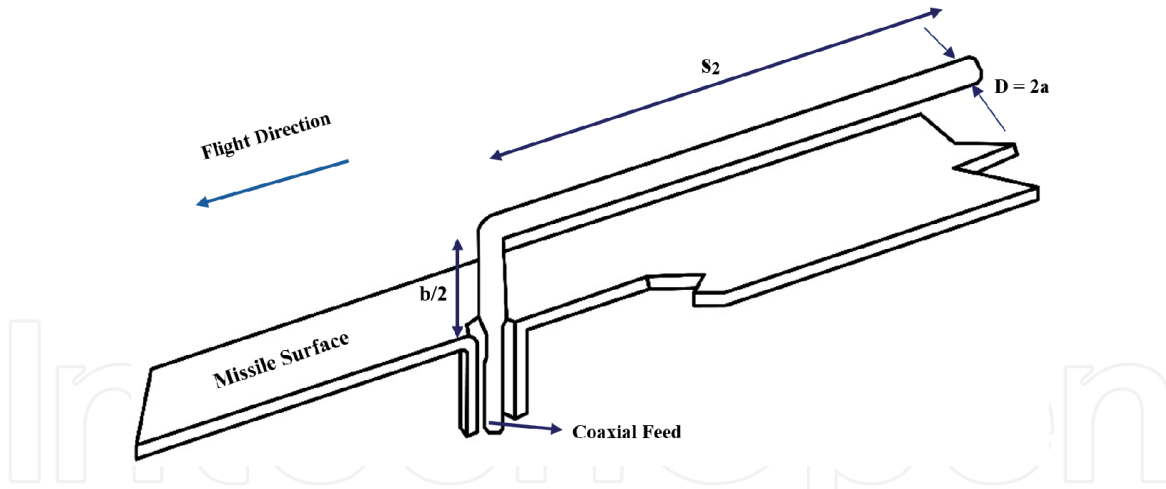

Figure 4.
Inverted L antenna for use on missiles [8].

Inverted L antenna is a simple wire antenna structure, which is folded on a point of a transmission line as illustrated in **Figure 4**. It should be emphasized that its open end is at the reverse direction to flight in order to afford aerodynamic conformity to the missile. It is fed by coaxial line. Distance between the ground surface of missile and the antenna wire is $b/2$, horizontal length of the antenna is s_2 and the diameter of wire that is used to form the antenna is $2a$. Inverted L antenna has been analyzed based on the transmission line theory in [8]. Therefore, the diameter of wire $2a$ and height over surface $b/2$ must be smaller than operating wavelength. The derived relations for transmission line modeling of these antennas are valid for $2a < 0.01\lambda$ and $b \leq 0.1\lambda$ as mentioned in [8].

Equivalent circuit model of inverted L antenna is shown in **Figure 5**.

Using transmission line theory radiation resistance of the antenna can be derived as

$$R^e = \frac{30\beta^2 b^2}{\sin^2 \beta s_2} \left\{ 1 - \frac{\sin 2\beta s_2}{2\beta s_2} \right\} \quad (1)$$

where β is phase constant for the transmission line [8].

The second type of transmission line antenna is shunt-driven inverted L antenna with open end as illustrated in **Figure 6**. In this case, there is a shorting line with a distance of s_1 from center of the feeding line. Again open end is opposite to the direction of flight.

Its equivalent circuit model is presented in **Figure 7**.

By using transmission line theory radiation resistance of the antenna can be derived as given in [8].

$$R^e = \frac{30\beta^2 b^2}{\cos^2 \beta s_2} \left\{ \frac{1}{2} [\cos^2 \beta s + \sin^2 \beta s_1 + \cos^2 \beta s_2] - \cos \beta s \cos \beta s_2 \frac{\sin \beta s_1}{\beta s_1} \right\}, \quad (2)$$

where $\cos \beta s \neq 0$

Here, $s = s_1 + s_2$. If this antenna is modified by adding a tunable capacitor instead of open end it will be easy to tune input impedance of the antenna. It is shunt-driven inverted L antenna with capacitive end loading. Its illustration is shown in **Figure 8**.

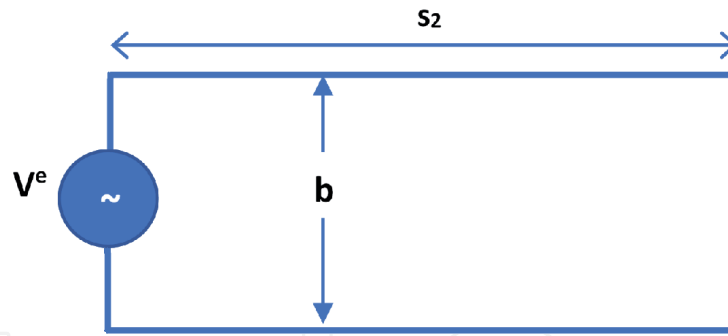

Figure 5.
 Equivalent circuit model of inverted L antenna: end-driven open-end section of line [8].

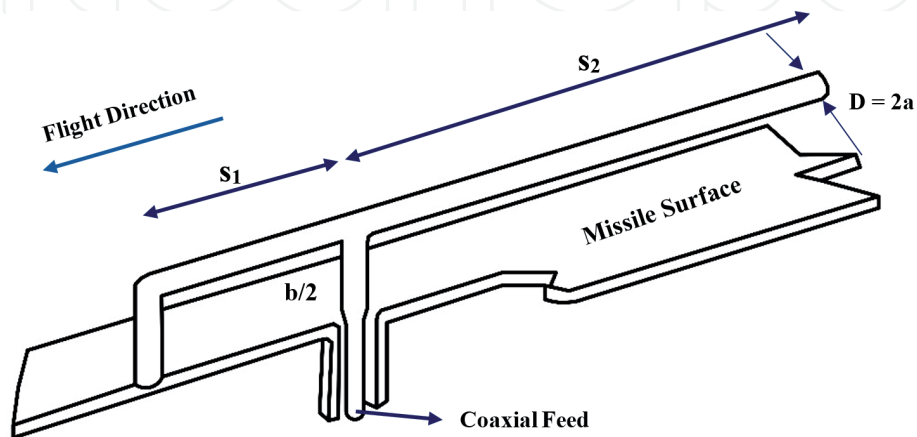

Figure 6.
 Shunt-driven inverted L antenna with open end for using on missiles [8].

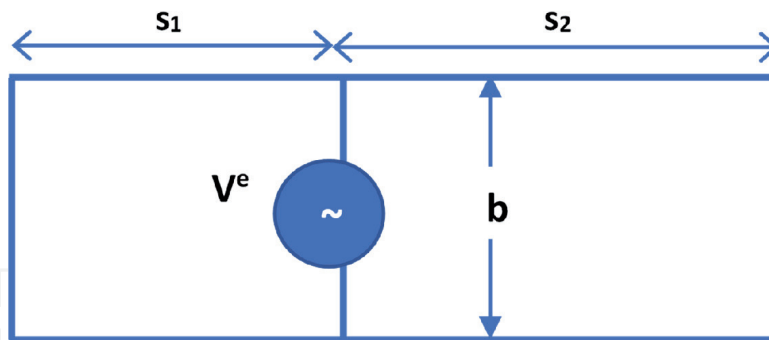

Figure 7.
 Equivalent circuit model of shunt-driven inverted L antenna with open end: shunt-driven line with an open and a short-circuited termination [8].

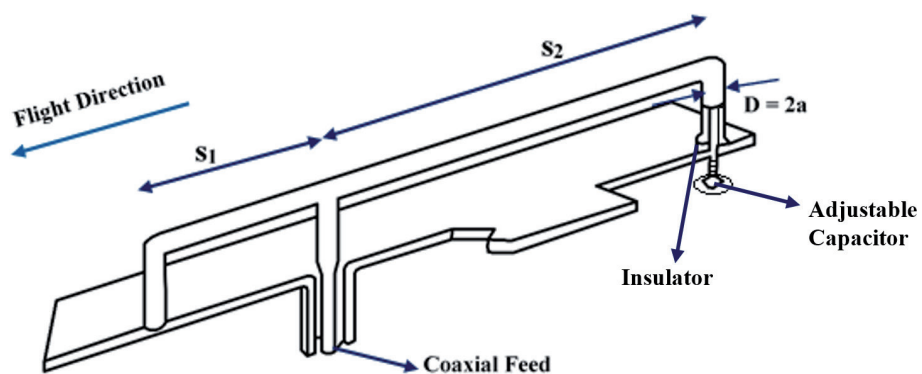

Figure 8.
 Shunt-driven inverted L antenna with capacitive end loading for using on missiles [8].

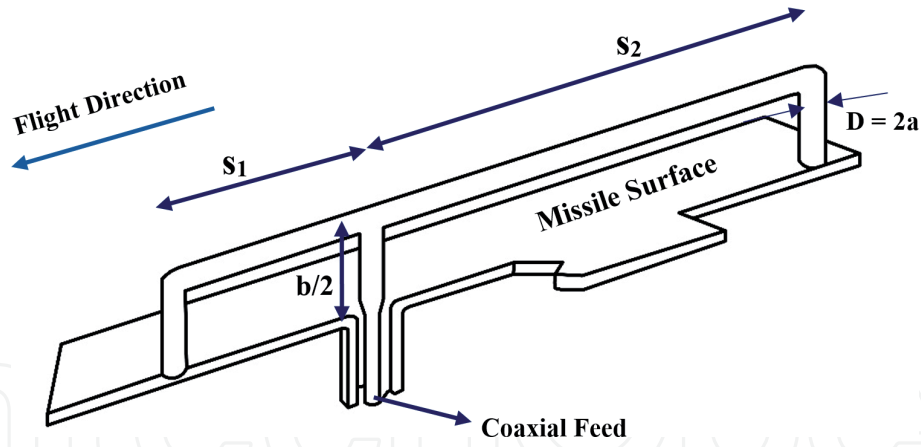

Figure 9. *m*-Antenna with capacitive end loading for using on missiles [8].

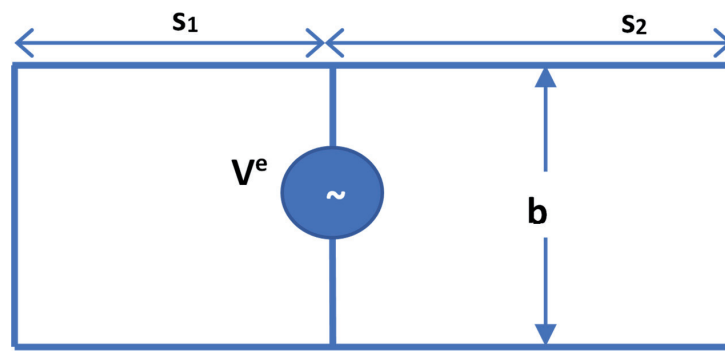

Figure 10. Equivalent circuit model of *m* antenna: shunt-driven line with short-circuited terminations [8].

In order to derive the radiation resistance of reactive element ended inverted L antenna the relations given in [9] can be used. For the sake of brevity, derivation of radiation resistance has not been given within text.

The final type of transmission line antenna is *m*-antenna. Its illustration is given in **Figure 9**.

Its equivalent circuit model is presented in **Figure 10**.

Similarly, as used in previous antenna types, using transmission line theory radiation resistance of the antenna can be derived as [8].

$$R^e = \frac{30\beta^2 b^2}{\sin^2 \beta s_2} \left\{ \frac{1}{2} \left[\sin^2 \beta s + \sin^2 \beta s_1 + \sin^2 \beta s_2 \right] - \left(\frac{s_1^2 + s_1 s_2 + s_2^2}{\beta s_1 s_2} \right) \sin \beta s \sin \beta s_1 \sin \beta s_2 \right\} \quad (3)$$

$(\sin \beta s \neq 0)$

and $s = s_1 + s_2$.

Up to date, many different versions of those basic antennas have been published in the literature. Particularly, their printed circuit versions are also available and used for different communication devices in cellular phones, tablets and portable computers as well.

4.1.2 Extremely thin and omnidirectional slot antenna array for launch vehicles

Another basic antenna used on missiles is conformal slot array structure. In order to get enhanced coverage for launch vehicles, array antennas are versatile

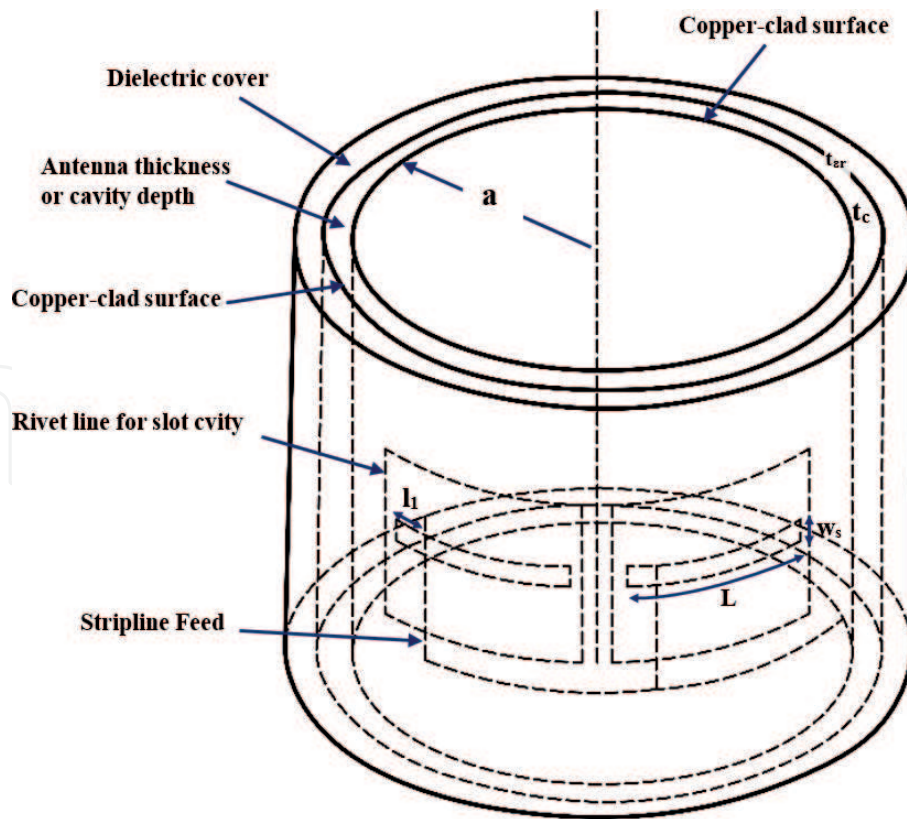

Figure 11.
 Outline drawing of stripline-fed cavity-backed slot array antenna on space launch vehicle [10].

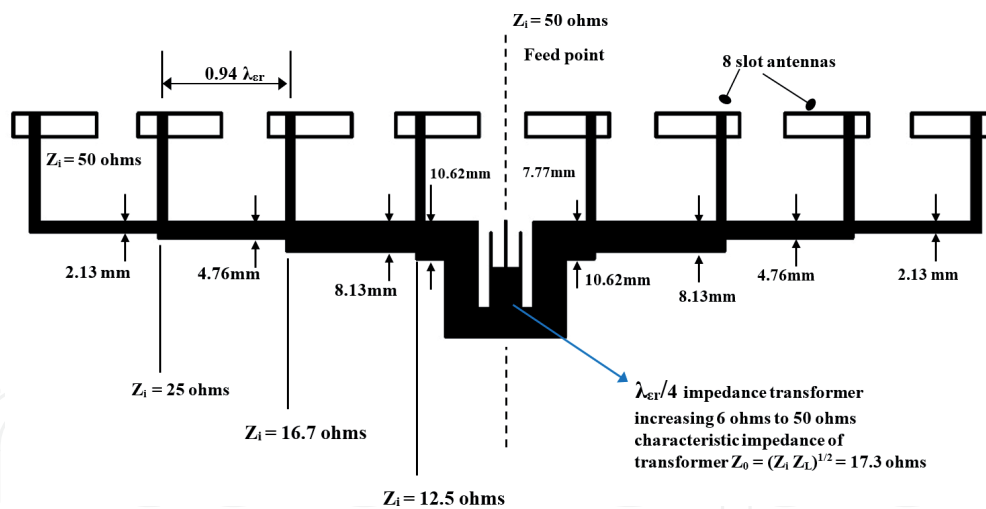

Figure 12.
 Series stripline feed structure for the array of eight slots [10].

and effective. Almost omnidirectional pattern can be achieved using circumferential or conformal array antennas on the launch vehicles. There are various examples for this type in the general literature. One of them is presented in [10] Its outline illustration is shown in **Figure 11**. As shown in this figure eight slot elements were used and to decrease the number of branch lines the author used series feedline as shown in **Figure 12**. Input impedance of each slot antenna element is designed as 50 Ω . Moreover, in **Figure 12** matching of the main input port of the array is explained in detail. For matching 6 Ω input impedance of eight-element slot array to 50 Ω , $\lambda/4$ transformer is employed at the input. To suppress higher order modes and edge excitation of the slots, bolts are inserted circumferentially to form a rectangular transmission line. In Ref. [10], it is particularly

Description	Dimensions (mm)
Single slot antenna	
Slot size without coating	64.77 × 2.54
Minimum cavity size	50.8 × 83.82 × 2.39
Feeding point position from end of slot to obtain 50 Ω	15.24
L (slot length) where $te_r = 0.15$	57.4
L (slot length) where $te_r = 0.10$	58.17
Array of slots	
L (slot length) where $te_r = 0.10$	55.88
Cavity size	50.8 × 83.82 × 2.310
Feeding point position from end of slot to obtain 50 Ωs	15.24

Table 2.
Physical design parameters of conformal stripline fed slot array antenna [10].

highlighted that spacing between each bolt and number of bolts are crucial to obtain continuous short circuit around slot aperture and also at transition area from RF connector to stripline feed.

Design parameters of this conformal array are presented in **Table 2**. Those physical design parameters were obtained for a substrate having a dielectric permittivity of 2.1 and a dielectric cover whose permittivity is 2.54. The dielectric cover was used to protect the array antenna from heat arising because of atmospheric friction. To obtain 50 Ω input impedance for each slot antenna, offset feeding technique was used.

Azimuth and elevation patterns of the array are presented in **Figures 13** and **14**, respectively. In these figures, omnidirectional radiation pattern characteristic is seen clearly around the launch vehicle.

In those figures red line represents the radiation pattern with superstrate and black dashed line represents radiation pattern without superstrate.

Today, different types of wrap around slot arrays are still being used on launch vehicles to form omnidirectional radiation pattern around the vehicle. The number of the array element can be increased depending on the circumferential electrical

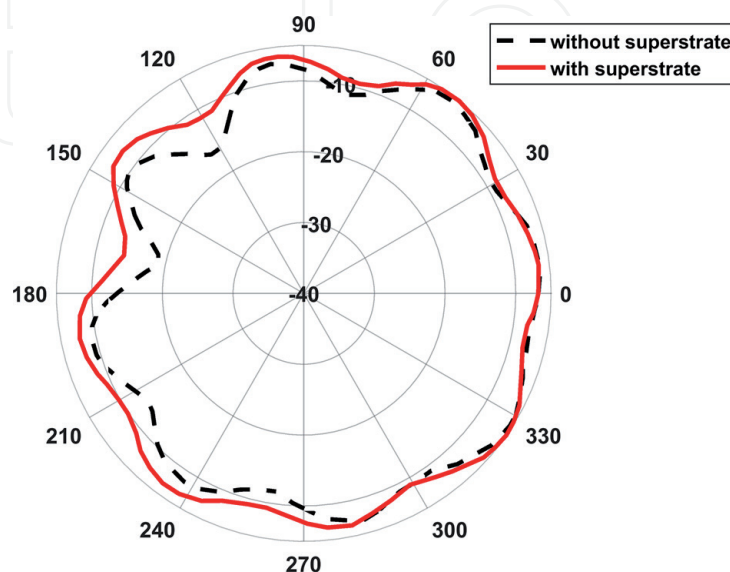

Figure 13.
Radiation pattern of the slot array in the azimuth plane with and without dielectric cover [10].

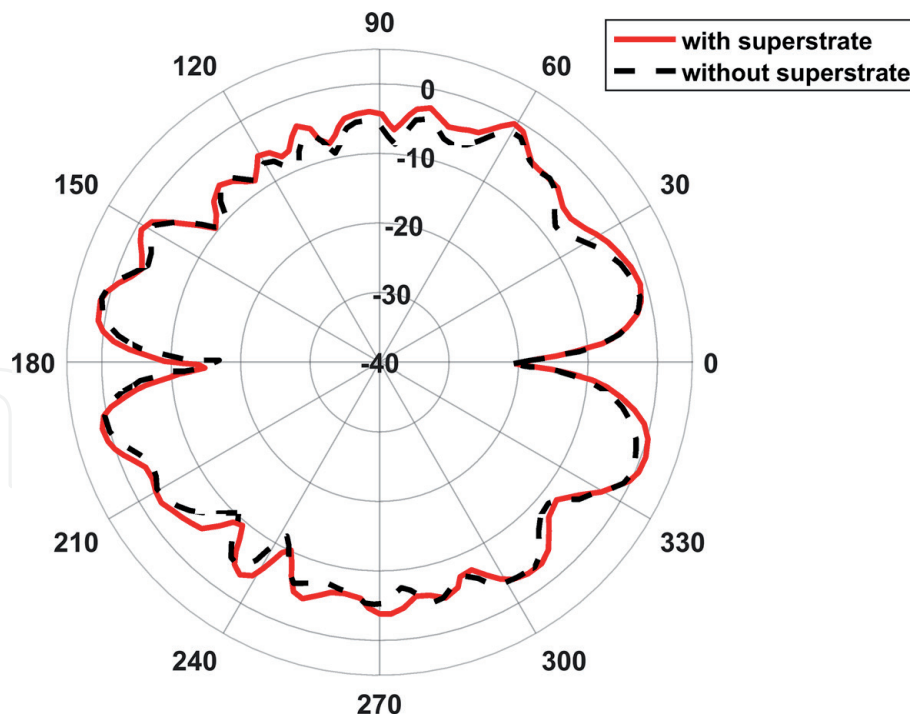

Figure 14.
Radiation pattern of the slot array in the elevation plane with and without dielectric cover [10].

length. Thanks to those antennas, TM/TC RF signals can be sent or received easily. An interested reader can find commercial products based on this type, since it has many advantages like ease of manufacturing and good conformity to aerodynamic structure of the vehicle.

4.2 Satellite antennas

Up to date, numerous antennas have been designed and employed for different space missions. As mentioned in previous parts, most of them are for satellite communication systems like TM/TC and PDT subsystems, broadcast payload etc. As given in the first section, satellites are usually categorized according to their orbits. Those orbits define and affect general characteristics of satellites to be designed and manufactured for power generation from their solar panels, communication period and slot with ground station, radiation endurance, parts to be used because of atmospheric effects like atomic oxygen and their payload specifications.

After frequency definition for subsystems, types of antennas to be used for communication, remote sensing instrument and scientific instruments are selected. For example, circularly polarized antennas are usually preferred for TM/TC antennas not to be affected from polarization mismatch, which can be caused by maneuvers during low earth orbiting phases and atmospheric effects like Faraday rotation [11]. Besides antennas used on small satellites should be as low profile as possible due to surface and volume restrictions. However, for PDT and remote sensing applications medium and high gain antennas are needed. To use high gain and therefore narrow beamwidth antennas efficiently, they should be steered whether directing whole satellite platform or using additional steering mechanism like electromechanical structures or electronically steerable phased array antenna systems.

As is well known there are different types of antennas used for satellites but since there is very limited place in this part, only some noteworthy ones will be taken into consideration and presented for the sake of brevity.

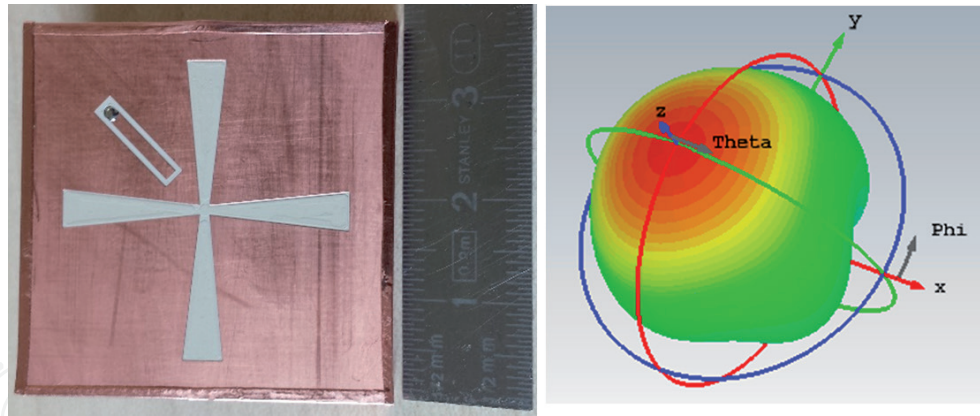

Figure 15. Manufactured prototype of cavity-backed antenna with tapered crossed-slot aperture and its 3D radiation pattern [13].

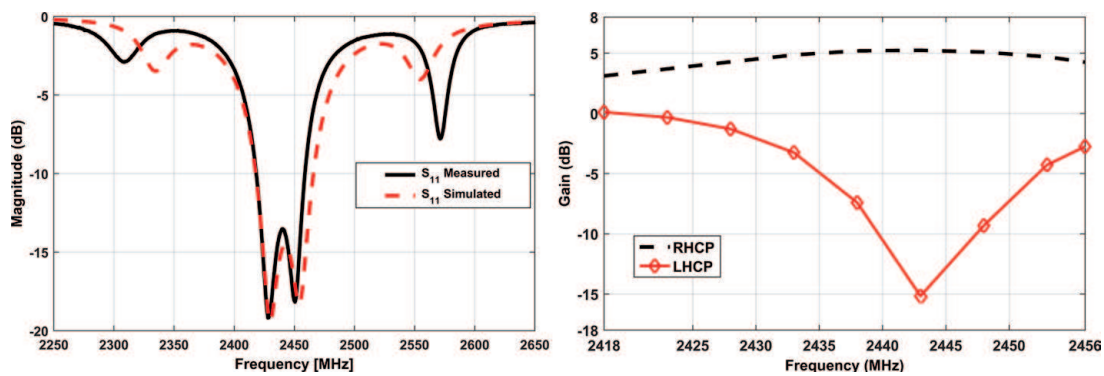

Figure 16. Measured S_{11} , co-pol and cross-pol gain results versus frequency for cavity-backed antenna with tapered-slot aperture [13].

4.2.1 Small antennas for tiny satellites

There is tremendous demand to accomplish space research at reasonable prices for universities and commercial entities therefore CubeSat is a practical and functional platform for this objective. Dimensions of a 1 U CubeSat are 100 mm x 100 mm and it has aluminum T6061 structure with a total mass of up to 1 kg. However, 1 U can be easily enlarged to larger sizes like 2 U, 3 U, etc. Comparing to other satellite platforms, CubeSats have limited volume therefore submodules and antennas should fit into those tiny platforms.

There are good small antenna study examples developed under GAMALINK¹ [12] project for CubeSat antennas and one of them is given in [13]. In this study a miniaturized cavity-backed tapered cross-slot antenna has been presented. $38 \times 38 \text{ mm}^2$ and $30 \times 30 \text{ mm}^2$ footprints have been obtained on substrates having dielectric permittivity 6 and 9.2, respectively, at operating frequency about 2.44 GHz. Manufactured prototype of the antenna and its simulated 3D radiation pattern are shown in **Figure 15**.

Its maximum gain is at boresight and efficiency is small as expected because of miniaturization. However, its tiny dimensions make this antenna beneficial to save space on surfaces of small spacecrafts like CubeSats. In addition, prototype was manufactured to verify the simulation results shown in **Figure 16** as mentioned

¹ GAMALINK (Generic SDR-based Multifunctional spAce LINK) is a project for European Union's FP7-Seventh Framework Programme for research, technological development and demonstration under grant agreement no 312830.

in [13]. S11, gain and cross pol gain are presented in this figure and the measured values support electromagnetic simulation results. These types of miniaturized antennas have low efficiency. Nonetheless, since they have small footprints they can be installed to the CubeSats easily especially for TM/TC communication and even for Inter Satellite Link (ISL). Therefore, for distinctive missions even 3 or 4 of them can be gathered to form an array.

However, an interested reader should review other studies where mesh and optically transparent or mesh type antennas are proposed as well as small antennas [14–22].

4.2.2 Deployable large antennas for tiny satellites

For some specific operations electrically large antennas can be needed on CubeSats. Those antennas are folded, stowed or packed in a CubeSat before and during launch process. After satellite platform is placed into orbit they are deployed to conduct their missions. For this aim, there are deployable antenna examples where cutting edge mechanical technologies are employed (Figure 17).

A stowed 0.5 m Ka-band mesh reflector antenna was installed into RaInCube platform to initiate usage of Ka-Band radar for meteorology on a low-cost and fast

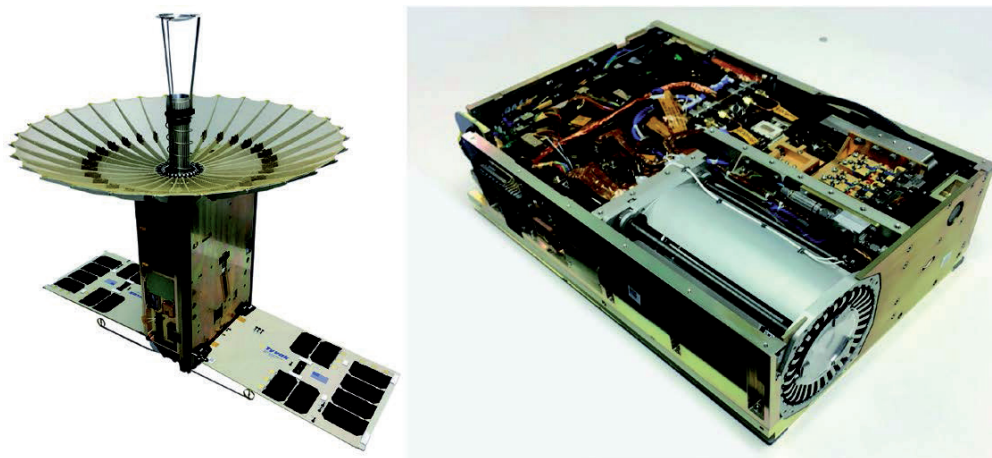

Figure 17. Ka-band deployable parabolic dish antenna which has 30 ribs similar to an umbrella to be stowed and installed into RaInCube platform. Left deployed and right stowed into RaInCube (image courtesy of NASA/JPL-Caltech).

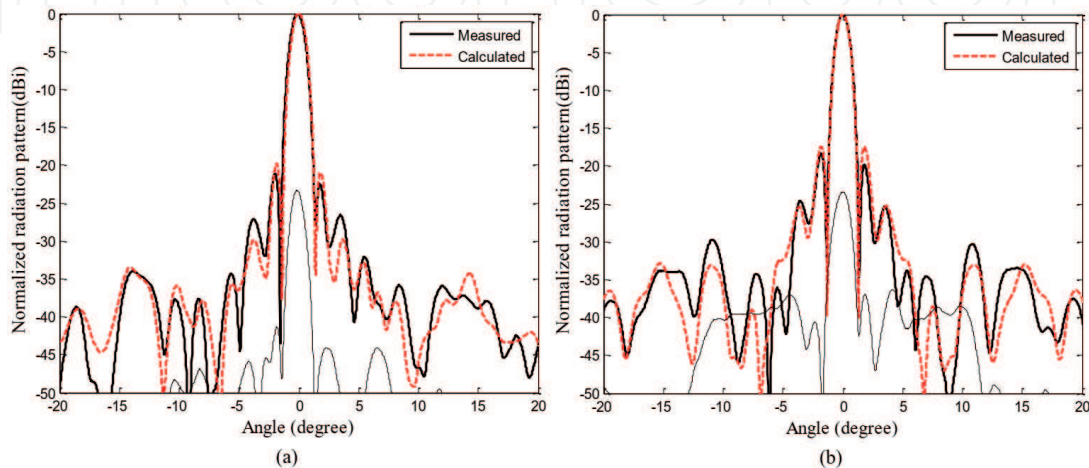

Figure 18. Measured and calculated radiation pattern of the deployable mesh reflector antenna model. (a) $\phi = 0^\circ$. (b) $\phi = 90^\circ$. (Reprinted, with permission, from [25], © 2016 IEEE).

applicable 6 U CubeSat platform of NASA [23–25]. The measured gain and efficiency of this antenna are 42.6 dBi and 52%, respectively, at 35.75 GHz [23].

Radiation pattern of the reflector antenna is given in **Figure 18**. Its beamwidth is about 1.2° in E- and H-planes. RaInCube was launched into a near circular orbit where its altitude of ~ 400 km and with inclination of 51.6° on 21 May 2018 and the mesh reflector antenna deployment process achieved on 28 July 2018.

4.2.3 GEO satellite communication antennas

In the past, GEO satellites' main mission was only television broadcasting and voice data transmission. Therefore, there are many communication satellites as geosynchronous. In the last decade, they have started evolving and internet communication mission has begun to take place instead of TV broadcasting. The main reason for this is that the internet goes into all areas of life like business, education, entertainment, etc.

Since GEO satellites are about 36,000 km away from earth, they need high effective isotropic radiated power (EIRP) levels. So usually large aperture reflector antennas are employed. Based on ITU regulations generally these antennas shape their beams according to geographical regions. This is because to reuse frequencies allocated over regions as shown in **Figure 3**.

There are many different applications of reflector antennas for GEO communication satellites [26–33].

There is a good example to illustrate evolutionary change of GEO communication satellites. To provide high speed internet data communication JAXA started The “KIZUNA” – Wideband InterNetworking engineering test and Demonstration Satellite (WINDS) project. Its main mission was to enable super high-speed data communications of up to 1.2 Gbps. In this way, everybody can reach high-speed communications, no matter in which geographical region of Japan they live. Its illustration and its payload antennas are shown in **Figure 19**.

As shown in **Figure 19** there are three payload antenna structures on the satellite. Two of them are Ka-Band multibeam reflector antennas and the other one is Ka-Band Active Electronically-Controlled Scanning Array (AESA) antenna. The multibeam antennas have 2.4 m diameter and in type of 2 offset-feed Cassegrain. The AESA has 128 elements to establish transmit and receive beams. Multibeam reflector antennas are responsible for Japan with Asia and AESA is operational for Pacific and partly Asia.

KIZUNA was launched and put into Geosynchronous Orbit to acquire the highest-speed data communication of the world in 2008. Its planned operational life was 5 years and failed in February 2019 and started to drift. Therefore, it exceeded its planned operational life successfully.

4.2.4 Reflector antennas

A big number of scientist and communication antenna specialists are working on the increase of performance properties of reflector antennas for the widely usage in deep space communication, satellite communication stations, radio astronomy, current microwaves such as radio-links and radars. Parabolic reflector antennas are preferred to use as main reflector in communication systems due to its high gain and directivity properties. Also, these types of reflector antennas can give the opportunity for usage in multi-band and multi beam applications. For these reasons parabolic reflector antennas have attracted the intense interest of researchers for many years [34, 35]. A simple and known physical structure of a parabolic reflector antenna is in **Figure 20**.

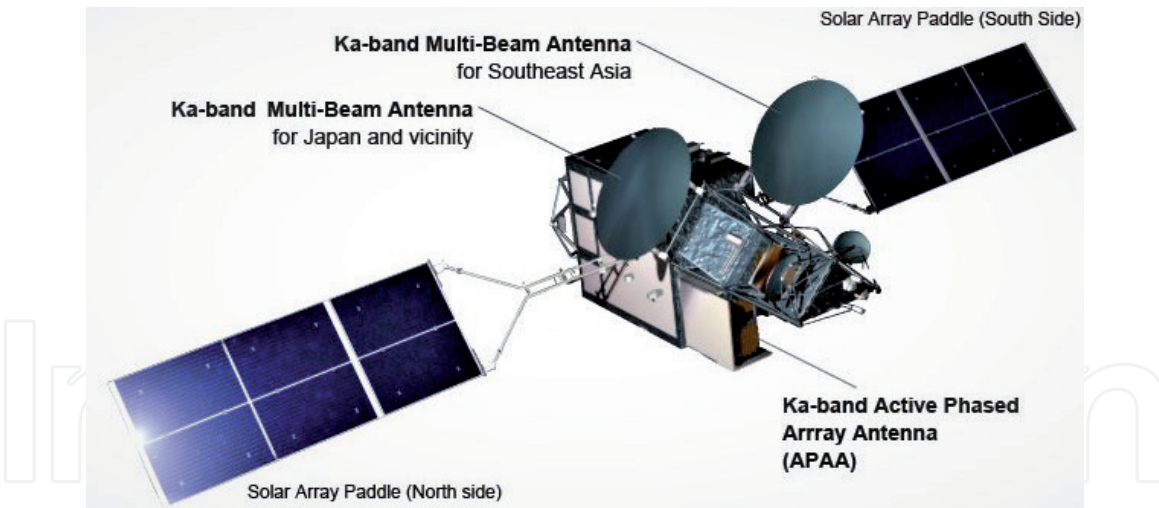

Figure 19.
KIZUNA” – WINDS high speed data communication satellite (image courtesy of JAXA).



Figure 20.
Parabolic reflector antennas at The NASA Deep Space Network Goldstone Ground Station Complex (image courtesy of NASA).

A parabolic reflector antenna consists of many important sections such as main reflector, feed, struts and control units, pedestal or support. Each of these should be carefully analyzed and designed.

Additionally, it is possible to use reflector antennas in various forms as:

- Receiver-transformer operation (single earth antenna at the end of down-up links on the same path) form
- Transmitter and receiver (two different earth antennas at the ends of uplink-satellite-downlink paths) form
- Transmitter, satellite control unit and receiver (three different earth antennas at the ends of uplink-satellite-control unit paths and control units-satellite-receiver paths) form
- A number of earth reflector antennas depending on coverage areas of satellites.

Parabolic reflector can be fed as in axisymmetric, asymmetric and off-focus fed forms as seen in **Figure 21**. Symmetric feeding causes aperture blockage effects of feed and struts. To avoid this blockage, asymmetric and off-focus fed forms are preferred. For multiple beam generation array type feedings have been used. The approximate maximum gain of a parabolic reflector is given as below:

$$G_{\max} = \frac{4\pi A_{\text{eff}}}{\lambda^2} \quad (4)$$

Here, A_{eff} is effective aperture area including the effect of losses due to spillover, aperture taper, Joule type heating and distortions on the surface of reflector.

Reflector antennas have different shapes such as parabolic, hyperbolic, elliptic, circular and line profiles. Although the shapes are quite different, for mathematical analysis they can be converted to each other by defining a parameter called eccentricity. Using eccentricity parameter, the whole family can be analyzed in a unified form [36]. Various shapes and their eccentricity values are illustrated in **Figure 22**.

Incident and reflected field directions for a feed located at the focus of parabolic and hyperbolic antennas are seen in **Figure 23**.

In order to increase gains of parabolic reflector antennas, dual antenna structures can be used. Cassegrain (main reflector parabolic antenna and sub-reflector hyperbolic reflector) and Gregorian (main reflector parabolic antenna and sub-reflector ellipsoid reflector) are two most common types of dual antennas. As an example, a Cassegrain type reflector antenna is presented in **Figure 24**.

A dual-antenna can be fed in symmetrical, asymmetrical and off-focus forms as given in **Figure 25**.

There are several methods for the analysis of reflector antennas. Physical optics (PO) comes first among the known methods [37]. As it is known, it gives the correct results for the main lobe and first side lobe patterns [38].

PO integral has main difficulty in application due to the complexity of the physical structure. The diffraction effects are also considered in order to obtain the full and correct radiation patterns particularly to determine side and back lobes. Physical theory of diffraction (PTD), equivalent edge currents (EEC) [39], aperture field method (AFM) and Jacobi-Bessel series method have been applied to find the radiation patterns for front space of reflector antenna [40]. The uniform theory of diffraction (UTD) [41–43]

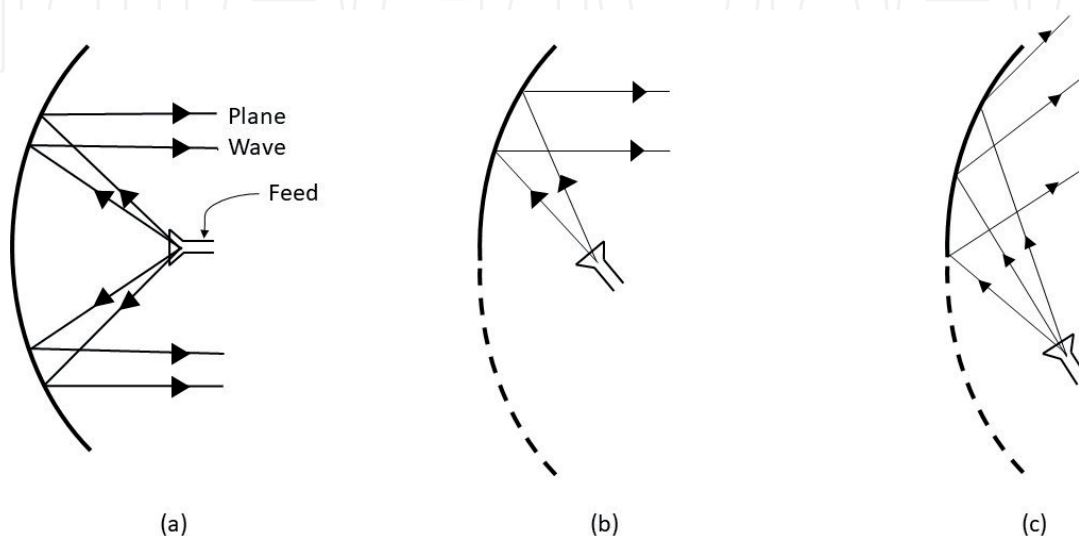

Figure 21. Feeding types of a parabolic reflector antenna, (a) symmetric, (b) asymmetric, and (c) off-focus fed.

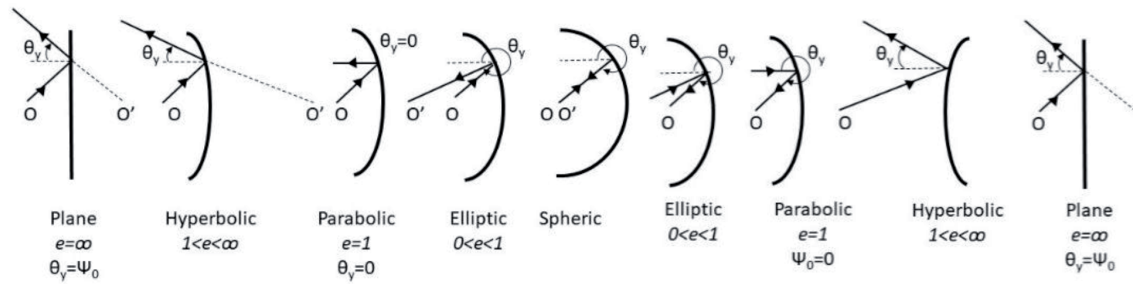

Figure 22.
 Variation of reflector shapes with eccentricity.

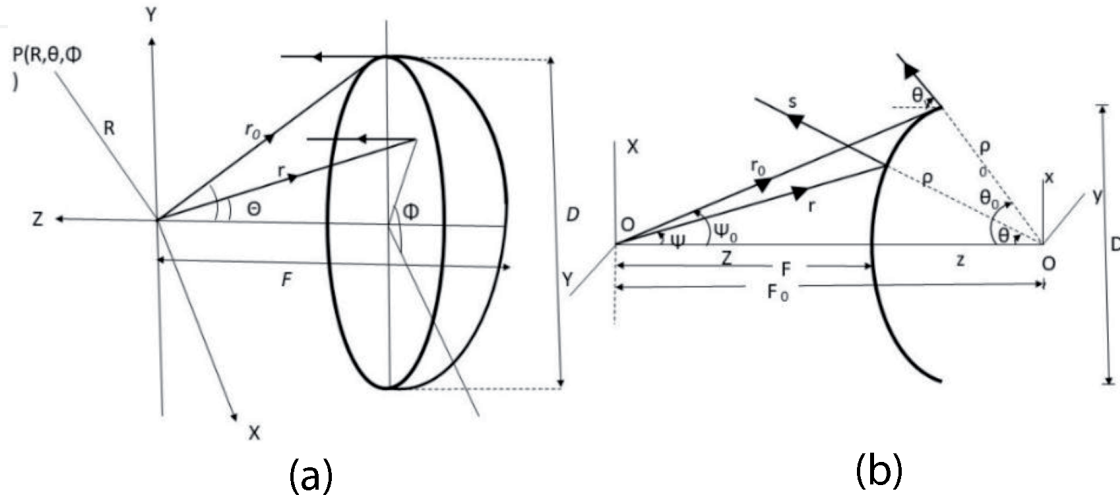

Figure 23.
 Incident and reflected field directions of a reflector antenna (a) parabolic and (b) hyperbolic.

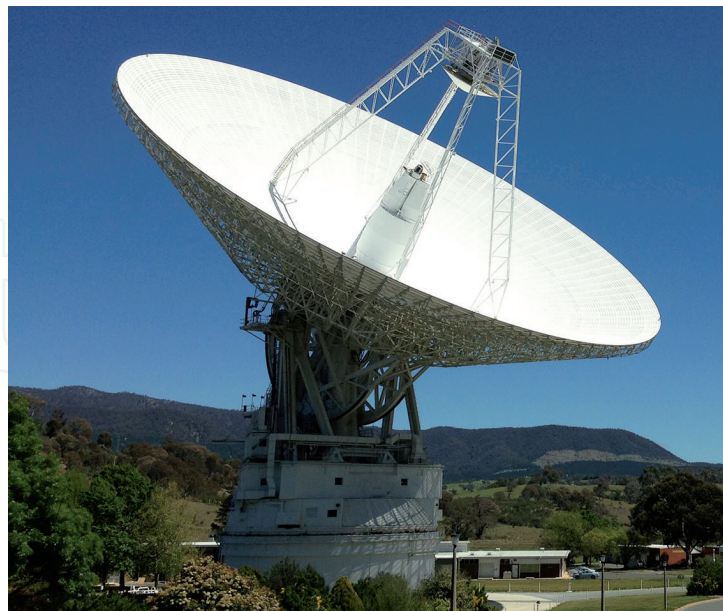

Figure 24.
 DSS-43 dish at the Canberra Deep Space Communication Complex (CDSCC): a Cassegrain antenna whose diameter is 70 m (image courtesy of NASA).

and the uniform asymptotic theory (UAT) [44] based on the geometrical theory of diffraction (GTD) [45, 46] can be used in the analysis of radiation patterns of reflector antennas for various directions. These methods applied to the analysis of reflector antennas by many researchers [44, 47, 48] as seen in **Figure 26**.

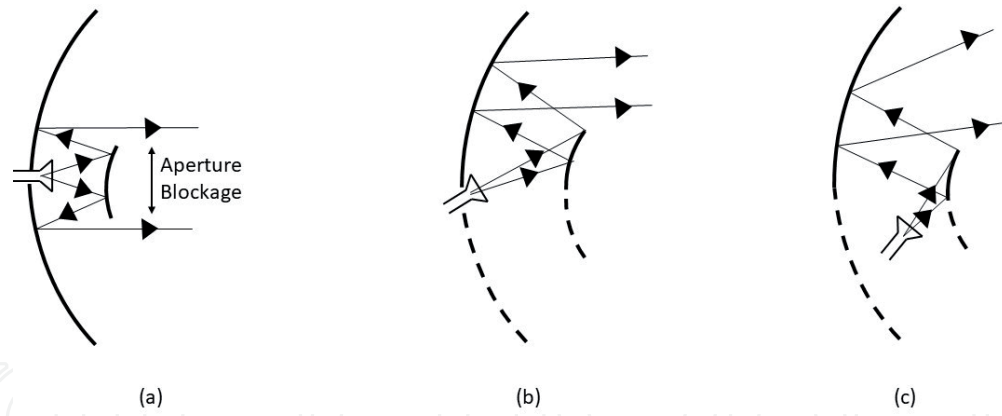

Figure 25. Feeding types of dual antennas, (a) symmetrical, (b) asymmetrical, and (c) off-focus.

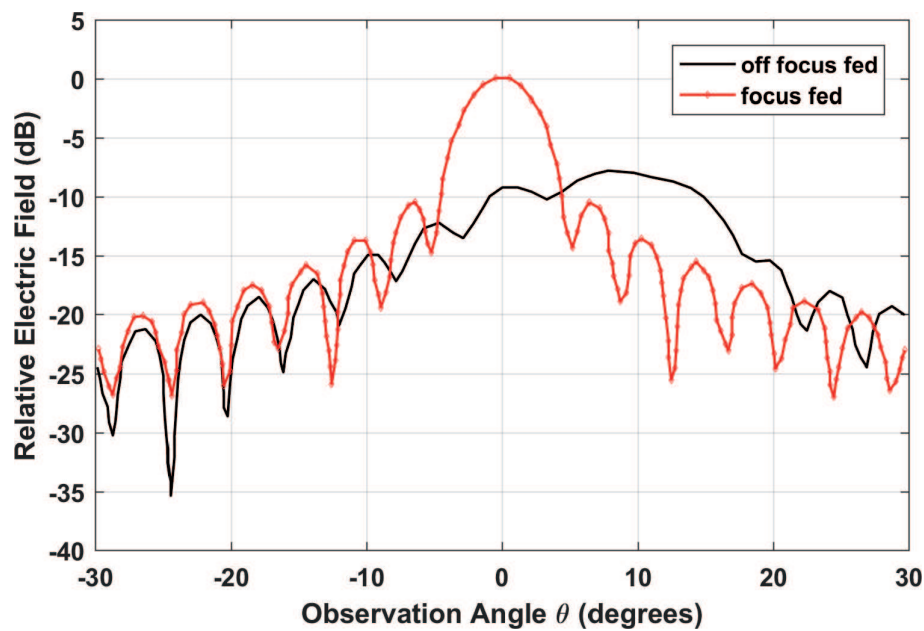

Figure 26. Radiation pattern of a parabolic reflector antenna, $D = 15\lambda$, $\alpha = \pi/3$, for focus fed [39] and off-focus fed with $f_x = f_y = f_z = \lambda$. [40].

The use of array type feeding has been preferred for easy beam scanning in single and dual-reflectors by some scientists [29]. Also in recent years, some new techniques have been developed in the analysis of off-focus fed and array feeding in single and dual reflectors for preventing aperture blockage of feeds, struts and subreflectors. These techniques are called as equivalent feed [49, 50] and equivalent parabola techniques [51]. By using the combination of these two techniques, it is possible to minimize side and back lobes [52, 53] (**Figure 27**).

As well known, it is important to reduce fields due to such lobes. Additional advantages of these techniques are optimization of the location of off-focus feeders and array elements. Thus beam scanning and corrections for catching the best receive/transmit signal are achieved. All these give the ability of increasing the performance of the space communication systems from the aspects of reflector antenna systems.

4.3 Antennas for deep space vehicles

For exploring other planets, comets, moons etc., space vehicles carrying scientific instrumentation are designed and launched. To compensate overmuch free

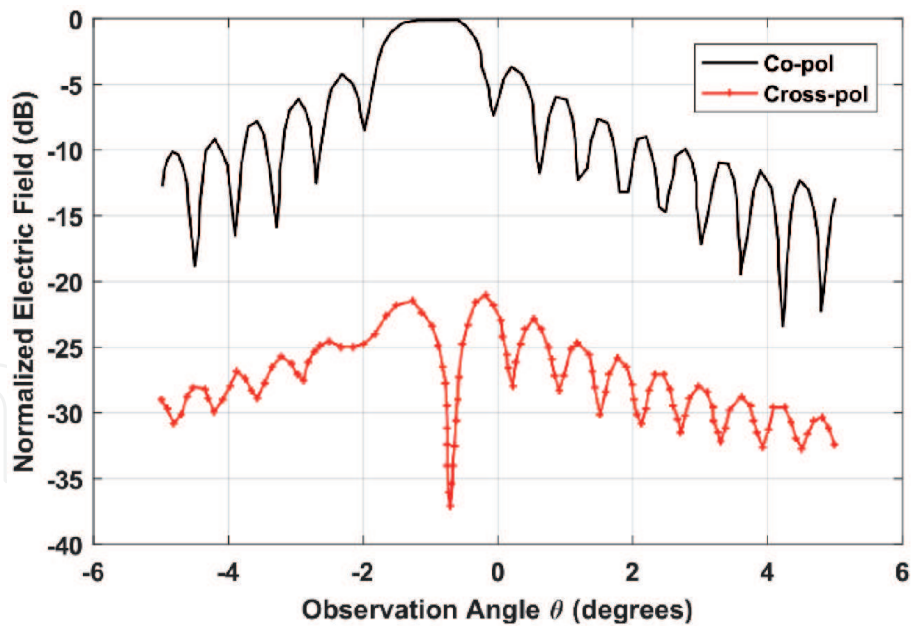

Figure 27. Radiation pattern of a defocused fed Cassegrain antenna with $D = 100\lambda$, $d_o = 90\lambda$, $F = 62.5\lambda$, $\beta = 150$, $e = 1.996$, $n = 8$ and $f_x = f_y = f_z = 3\lambda$ by using equivalent feed and equivalent paraboloid techniques [40, 53].

space loss in communication budget, high gain antennas are needed. Therefore, challenging design and manufacturing technologies are employed for those antennas. Moreover, they have to comply with hard space qualification standards to operate in harsh space environment.

High gain antenna (HGA) on Mars rover *Curiosity of Mars Science Laboratory (MSL)* can be given as a pertinent example. HGA was developed by EADS CASA Espacio for NASA/JPL-Caltech [54]. This is circularly polarized microstrip patch array antenna consisting of 48 elements on a gimbal system to send and receive data between Mars and Earth at X-band.

In **Figure 28**, Engineering Qualification Model (EQM) of HGA is seen. The gimbal system has two degree of freedom for pointing. This RHCP antenna's gain values for Rx and Tx frequencies are listed in **Tables 3** and **4**, respectively, at different elevation angles.

This antenna is still being used on *Curiosity* at X-Band for uplink and downlink data from Mars surface to Earth. Its image taken by itself on Mars is shown in **Figure 29**.



Figure 28. EQM of HGA used for MSL (image taken from [54]; ©EurAAP; used with permission).

	At $\Theta = 2^\circ$		At $\Theta = 5^\circ$	
	Measured gain (dBi)	Required gain (dBi)	Measured gain (dBi)	Required gain (dBi)
7145 MHz	21.4	18	18.9	16
7170 MHz	21.5		18.8	
7195 MHz	21.5		18.8	

Table 3.
Rx gain values of HGA [54].

	At $\Theta = 2^\circ$		At $\Theta = 3.8^\circ$	
	Measured gain (dBi)	Required gain (dBi)	Measured gain (dBi)	Required gain (dBi)
8390 MHz	22.9	21.5	20.7	19.5
8420 MHz	22.9		21.1	
8455 MHz	22.7		20.7	

Table 4.
Tx gain values of HGA [54].

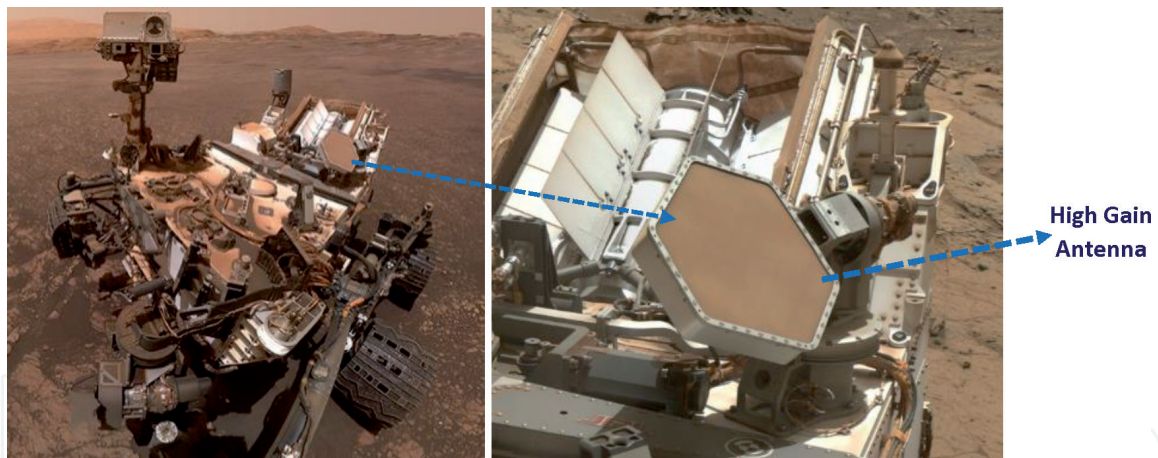

Figure 29.
HGA shown on Curiosity Mars rover (image courtesy of NASA/JPL-Caltech).

MSL was launched on 26 November 2011 and landed on 5 August 2012 onto Mars surface successfully. It was still working while this book chapter was being written.

Another challenging antenna design and application for deep space mission is *Mars Cube One* (MarCO) project of NASA/JPL-Caltech. NASA launched a Mars lander whose name is *Interior Exploration using Seismic Investigations, Geodesy and Heat Transport* (InSight) to Mars on 5 May 2018. There were two accompanying CubeSats: MarCO-A and MarCO-B to relay data to Earth from InSight on Mars [55]. As shown in **Figure 30** there is a deployable X-Band reflectarray antenna on the back surface of solar arrays.

The main task of this antenna with X-Band transponder is to support the communication of NASA's Mars Reconnaissance Orbiter (MRO) for downlink of the telemetries during InSight Rover's entry, descent and landing phases. This reflectarray antenna has 29.2dBic gain at X-Band as mentioned in [55].

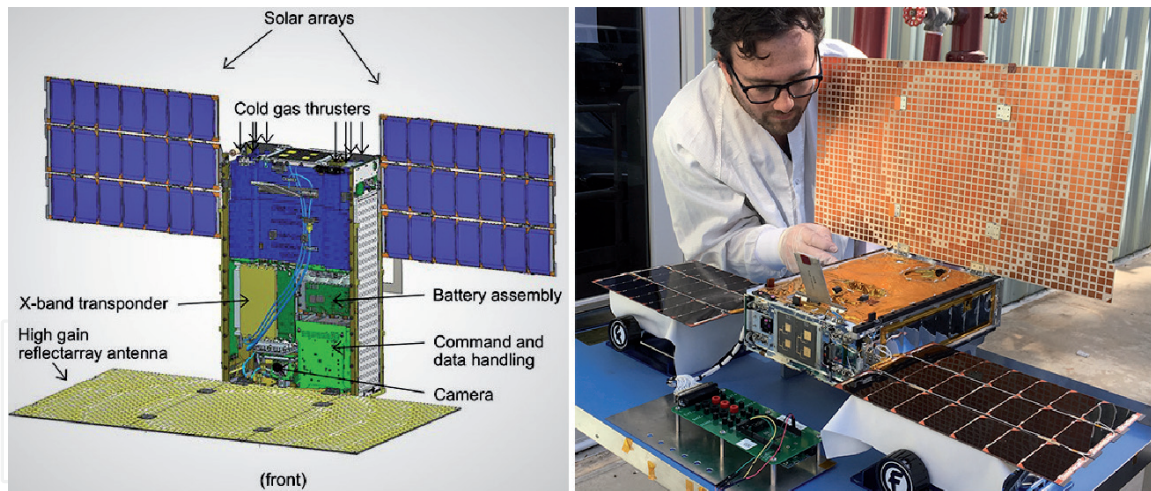

Figure 30.
Front view of MarCO CubeSat (image courtesy of NASA/JPL-Caltech).

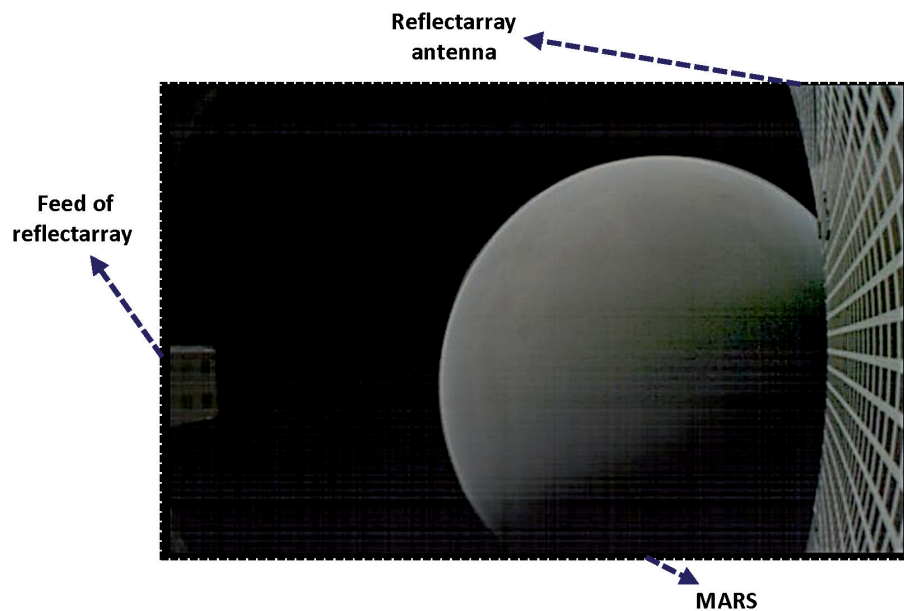

Figure 31.
Deployed reflectarray antenna with Mars scene. This photo was taken by onboard camera with fisheye lens of MarCO-B (image courtesy of NASA/JPL-Caltech).

An impressive image was taken by onboard camera with fisheye lens of MarCO-B after reflectarray antenna and its feed were deployed as given in **Figure 31**. In this figure, reflectarray elements and microstrip patch array feed of it are seen obviously. MarCO sent related telemetries from InSight successfully until its contact with the ground station was lost in February 2019.

Since reflectarray antennas have low stowage volume, manufacturing easiness using printed circuit board technology and lightweight mass, they became attractive in space industry. TUBITAK² Space Technologies Research Institute started a project named as YADAS in 2015 to develop X-Band reflectarray antenna to be used on LEO satellites [56]. Through this project many reflectarray prototypes in different element arrangements were designed, manufactured and measured. In **Figures 32** and **33**, simulation and measurement of the reflectarray antenna where the elements have been arranged in rectangular form at X-Band are shown.

² TUBITAK: The Scientific and Technological Research Council of Turkey.

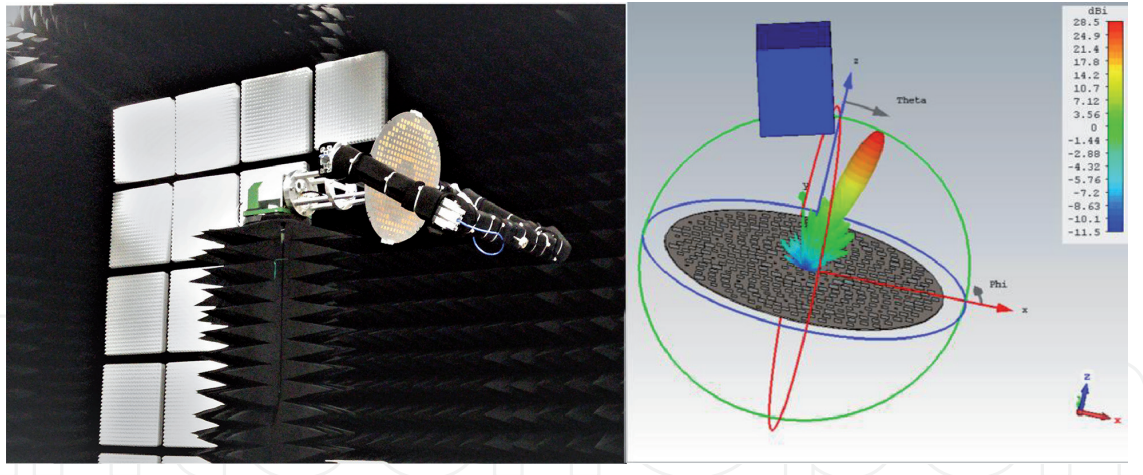

Figure 32. Simulated and measured reflectarrays within YADAS project at X-band [56] (image courtesy of TUBITAK Space Technologies Research Institute).

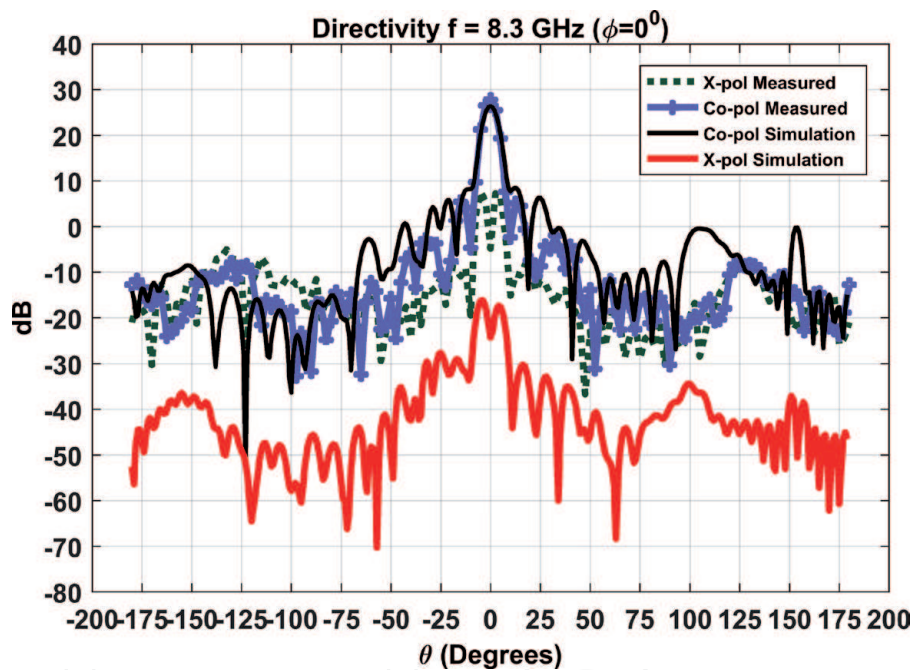

Figure 33. Directivity comparison of simulation and measurement result for reflectarray antenna where the elements have been arranged in rectangular form (YADAS) [56] (image courtesy of TUBITAK Space Technologies Research Institute).

The developed antennas reached Technology Readiness Level (TRL) 4. Some studies are going on to bring beam-shaping capabilities to the designed reflectarrays.

5. Conclusions

Since Sputnik-1 was launched into orbit, the space technologies and antennas for spacecraft and satellite communications have been making progress rapidly. Thanks to this progress humankind have been learning about planets, comets, stars and moons, briefly near, deep and even interstellar space. Moreover, exploiting this technology, people can communicate with each other easily even if they are not in same country or continent. This is also an important cause of globalization.

In this chapter, antennas have been discussed as an RF-front end element of communication subsystems on spacecrafts and satellites. As can be seen from subsections of the chapter, there are many different antenna types used to provide communication services of space vehicles. Because of the limited space and for the sake of brevity only remarkable ones have been given as examples. An interested reader can find many other antenna examples used for space applications in open literature. Design parameters and their types are generally defined according to their frequency bands, transmit RF power, mass and volume requirements, mission type and environmental conditions. Therefore, like other equipment and subsystems to be used on the mission, they should be tested based on the published standards. Many of parts of these standards have been created from past mission experiences, experiments and trials. Two well-known space agencies, NASA and ESA have been publishing detailed standard documents and they are continuously updating them based on the “lessons learned” and experimental improvements.

Today countries are trying to enhance budget and qualified man power devoted to the space all over the world. Because they know that by this means they can develop many different technologies in fields of aerospace, defense, and mobile communication. Nevertheless, space industry is a long-term investment and it needs passion, sustainability, and also patience, because in this technological area the final product emerges after many detailed research and development stages.

Acknowledgements

The authors would like to express special thanks to TUBITAK Space Technologies Research Institute (TUBITAK UZAY), National Aeronautics and Space Administration (NASA), Japan Aerospace Exploration Agency (JAXA), The Institute of Electrical and Electronics Engineers (IEEE) and the European Association on Antennas and Propagation (EurAAP) for permissions of some specific photographs and figures to use in this chapter. The authors also thank to Dr. Asli ER AKAN for editing and redrawing figures within the text.

Abbreviations

AESA	active electronically-controlled scanning array
AFM	aperture field method
ASS	amateur satellite service
bps	bit per second
BSS	broadcasting satellite service
CDSCC	Canberra Deep Space Communication Complex
EEC	equivalent edge currents
EES	Earth exploration satellite service
ECSS	The European Cooperation for Space Standardization
EIRP	effective isotropic radiated power
EQM	engineering qualification model
ESA	European Space Agency
ESTEC	European Space Research and Technology Centre
EurAAP	European Association on Antennas and Propagation
FSS	fixed satellite service
GEVS	general environmental verification standard
GEO	geostationary orbit
GNSS	global navigation satellite system

GTD	geometrical theory of diffraction
HGA	high gain antenna
HEO	high elliptical orbiting
IEEE	The Institute of Electrical and Electronics Engineers
InSight	Seismic Investigations, Geodesy and Heat Transport
ISL	inter satellite link
ISS	International Space Station
ITU	International Telecommunication Union
JAXA	Japan Aerospace Exploration Agency
JPL-Caltech	Jet Propulsion Laboratory-California Institute of Technology
LEO	low earth orbiting
LEOP	launch and early orbiting phase
LOS	line of sight
MarCO	Mars Cube One
MEO	middle earth orbiting
MRO	Mars Reconnaissance Orbiter
MSS	mobile satellite service
NASA	National Aeronautics and Space Administration
NSSDCA	NASA Space Science Data Coordinated Archive
PMSE	programme making and special events
PDT	payload data transfer
PO	physical optics
PTD	physical theory of diffraction
RF	radio frequency
RSS	radio determination satellite service
SMD	surface mount device
SOS	space operation service
SRS	space research service
TED	Türkiye Eğitim Derneği
TM/TC	telemetry/telecommand
TRL	technology readiness level
TUBITAK	The Scientific and Technological Research Council of Turkey
TV	television
UAT	uniform asymptotic theory
UNOOSA	United Nations Office for Outer Space Affairs
USSR	Union of Soviet Socialist Republics
UTD	uniform theory of diffraction
WINDS	Wideband Inter Networking engineering test and Demonstration Satellite

IntechOpen

Author details

Volkan Akan^{1*} and Erdem Yazgan²

1 Microwave and Antenna Systems Group, TUBITAK Space Technologies Research Institute, Ankara, Turkey

2 Department of Electrical and Electronics Engineering, TED University, Ankara, Turkey

*Address all correspondence to: volkan.akan@tubitak.gov.tr

IntechOpen

© 2020 The Author(s). Licensee IntechOpen. This chapter is distributed under the terms of the Creative Commons Attribution License (<http://creativecommons.org/licenses/by/3.0>), which permits unrestricted use, distribution, and reproduction in any medium, provided the original work is properly cited. 

References

- [1] Imbriale WA, editor. *Spaceborne Antennas for Planetary Exploration*. New Jersey, Wiley: Hoboken; 2006. 592 pp. DOI: 10.1002/0470052783
- [2] Öncü E, Akan V. Single stub tuning application via semi-rigid coaxial cables for VHF and UHF monopole antennas on RASAT. In: 10th Mediterranean Microwave Symposium (MMS'10); 25-27 August 2010; Guzelyurt, Cyprus. 2010
- [3] Ozturk F, Akan V, Topalli K, et al. Complex permittivity measurements of dielectrics for space antenna radome and substrates in x-band. In: International Applied-Computational-Electromagnetics-Society Symposium – (ACES); 26-30 March 2017; Firenze, Italy. 2017
- [4] NASA Outgassing Data for Selecting Spacecraft Materials [Internet]. 2018. Available from: <https://outgassing.nasa.gov> [Accessed: April 20, 2020]
- [5] ITU Booklet on National Frequency Management. Geneva; 1988
- [6] International Telecommunication Union (ITU). Radio Regulations. Articles. 2016;1
- [7] Frequency Allocations. [Internet]. Available from: http://www.grss-ieee.org/frequency_allocations.html [Accessed: April 20, 2020]
- [8] King R, Harrison CW, Denton DH. Transmission-line missile antennas. *IRE Transactions on Antennas and Propagation*. 1960;8:88-90. DOI: 10.1109/TAP.1960.1144802
- [9] King RWP, Harrison CW. *Antennas and Waves: A Modern Approach*. Massachusetts, USA: The MIT Press; 1969. 778 pp. ISBN-10: 0262110334
- [10] Campbell TG. An Extremely Thin, Omnidirectional, Microwave Antenna Array for Spacecraft Applications. Hampton, VA, United States: NASA Langley Research Center; 1969
- [11] Akan V, Yazgan E. Analysis and design of circularly polarized and frequency tunable microstrip antenna having conical radiation pattern characteristic. In: 32nd ESA Antenna Workshop on Antennas for Space Applications, European Space & Technology Centre (ESA/ESTEC); 05-08 October 2010; Noordwijk, Netherlands. 2010
- [12] Akan V, Dudak C. Antenna subsystem of GAMALINK platform. In: 6th European CubeSat Symposium; 14-16 October 2014; Estavayer-le-Lac, Switzerland. 2014
- [13] Akan V. Electrically small printed antenna for applications on CubeSat and nano-satellite platforms. *Microwave and Optical Technology Letters*. 2015;57:891-896. DOI: 10.1002/mop.28989
- [14] Mizuno TJ, Roque JD, Murakami BT, et al. Antennas for distributed nanosatellite networks. In: IEEE/ACES International Conference on Wireless Communications and Applied Computational Electromagnetics; April 2005; Honolulu, HI, USA. 2005
- [15] Murakami BT, Ohta AT, Tamamoto MA, et al. Self-steering antenna arrays for distributed picosatellite networks. In: 17th Annual/USU Conference on Small Satellites; Utah, USA. 2003. pp. 1-5
- [16] Simons RN, Lee RQ. Feasibility study of optically transparent microstrip patch antenna. In: IEEE Antennas and Propagation Society International Symposium and Digest; 13-18 July 1997; Montreal, Quebec, Canada. 1997
- [17] Turpin TW, Baktur R. Meshed patch antennas integrated on solar cells. *IEEE*

Antennas and Wireless Propagation Letters. 2009;**8**:693-696. DOI: 10.1109/LAWP.2009.2025522

[18] Volakis JL, Chen C-C, Fujimoto K. Small Antennas: Miniaturization Techniques and Applications. New York: McGraw-Hill; 2010. 448 pp. ISBN-10: 0071625534

[19] Chen SY, Chou HT, Chiu YL. A size reduced microstrip antenna for the applications of GPS signal reception. In: IEEE Antennas and Propagation Society International Symposium; 9-15 June 2007; Honolulu, HI, USA. 2007

[20] Leisten O, Vardaxoglou JC, McEvoy SP, Wingfield RA. Miniaturized dielectrically loaded quadrifilar antenna for GPS. Electronics Letters. 2001;**37**:1321-1322. DOI: 10.1049/el:20010906

[21] Sievenpiper DF, Dawson DC, Jacob MM, et al. Experimental validation of performance limits and design guidelines for small antennas. IEEE Transactions on Antennas and Propagation. 2012;**60**:8-9. DOI: 10.1109/TAP.2011.2167938

[22] Akan V, Köse S, Kuzu L. Simulation and realization of a miniaturized tunable microstrip patch antenna. In: 31st International Review of Progress in Applied Computational Electromagnetics; 22-26 March 2015; Williamsburg, USA. 2015

[23] Chahat N et al. CubeSat deployable Ka-band mesh reflector antenna development for earth science missions. IEEE Transactions on Antennas and Propagation. 2016;**64**:2083-2093. DOI: 10.1109/TAP.2016.2546306

[24] Chahat N. A mighty antenna from a tiny CubeSat grows. IEEE Spectrum. 2018;**55**:33-37. DOI: 10.1109/MSPEC.2018.8278134

[25] Chahat N et al. Ka-band high-gain mesh deployable reflector

antenna enabling the first radar in a CubeSat: RainCube. In: 2016 10th European Conference on Antennas and Propagation (EuCAP); 10-15 April 2016; Davos, Switzerland. 2016

[26] Wan J, Lu S, Wang X, Ai Y. A steerable spot beam reflector antenna for geostationary satellites. IEEE Antennas and Wireless Propagation Letters. 2016;**15**:89-92. DOI: 10.1109/LAWP.2015.2430894

[27] Jensen L, Sekora R, Schröder N. Advanced reflector antennas for geostationary spacecraft. IETE Technical Review. 1999;**16**:19-25. DOI: 10.1080/02564602.1999.11416798

[28] Greda LA, Winterstein A, Dreher A, et al. A satellite multiple-beam antenna for high-rate data relays. Progress in Electromagnetics Research. 2014;**149**:133-145. DOI: 10.2528/PIER14072502

[29] Saka B, Yazgan E. Pattern optimization of a reflector antenna with planar-array feeds and cluster feeds. IEEE Transactions on Antennas and Propagation. 1997;**45**:93-97. DOI: 10.1109/8.554245

[30] Alexovich J et al. The Hughes geo mobile satellite system. In: Proceedings of the Fifth International Mobile Satellite Conference; June 1997; Pasadena, CA. 1997

[31] Ekelman EP, Lee BS. An array-fed, dual-reflector antenna system (of offset confocal paraboloids) for satellite antenna applications. In: IEEE Symp. Antennas Propag.;, 26-30 June 1989; San Jose, CA, USA. 1989

[32] Thomson M. The Astromesh deployable reflector. In: IEEE Symp. Antennas and Propag.;, 11-16 July 1999; Orlando, FL, USA. 1999

[33] Chandler C, Hoey L, Hixon D, et al. Ka-band communications satellite

antenna technology. In: 20th International AIAA Communication Satellite Systems Conference; 12-15 May 2002; Montreal, Quebec, Canada. 2002

[34] Balanis CA. *Antenna Theory*. 3rd ed. New York, NY, USA: Wiley; 2005, 1136 pp. ISBN-13: 978-0471667827

[35] Rahmat-Samii Y, Haupt RL. Reflector antenna developments; a perspective on the past, present, and future. *IEEE Antennas and Propagation Magazine*. 2015;57:85-95. DOI: 10.1109/MAP.2015.2414534

[36] Yazgan E. A simple formulation of UTD for some reflector antennas. *International Journal of Electronics*. 1989;66:283-288. DOI: 10.1080/00207218908925385

[37] Love AW. *Reflector Antennas*. Piscataway, NJ: IEEE Press; 1978, 428 pp. ISBN-13: 978-0471046066

[38] Scott C. *Modern Methods of Reflector Antenna Analysis and Design*. Boston: Artech House; 1990, 144 pp. ISBN-13: 978-0890064191

[39] James GL, Kerdelidis V. Reflector antenna radiation pattern analysis by equivalent edge currents. *IEEE Transactions on Antennas and Propagation*. 1973;21:19-24. DOI: 10.1109/TAP.1973.1140409

[40] Wood PJ. *Reflector Antenna Analysis and Design*. London: Peter Peregrinus Ltd.; 1980, 221 pp. ISBN-13: 978-0906048214

[41] Yazgan E, Şafak M. Comparison of UTD and UAT in axially symmetric reflectors. *IEEE Transactions on Antennas and Propagation*. 1987;35:113-116. DOI: 10.1109/TAP.1987.1143965

[42] Yazgan E, Göksel H. The effect of surface loading on the radiation pattern of a spherical reflector. *IEEE Transactions on Electromagnetic*

Compatibility. 1988;30:561-563. DOI: 10.1109/15.8770

[43] Yazgan E. The radiation pattern of a surface loaded ellipsoidal reflector. *IEEE Transactions on Antennas and Propagation*. 1987;35:437-439. DOI: 10.1109/TAP.1987.1144102

[44] Lee SW. Comparison of uniform asymptotic theory and Ufimtsev's theory in electromagnetic edge diffraction. *IEEE Transactions on Antennas and Propagation*. 1977;25:162-170. DOI: 10.1109/TAP.1977.1141559

[45] Keller JB. Geometrical theory of diffraction. *Journal of the Optical Society of America*. 1977;52:116-130. DOI: 10.1364/JOSA.52.000116

[46] Kouyoumjian RG, Pathak PH. A uniform geometrical theory of diffraction for an edge in a perfectly conducting surface. *Proceedings of the IEEE*. 1974;62:1448-1461. DOI: 10.1109/PROC.1974.9651

[47] Rudge AW, Adatia NA. Offset-parabolic-reflector antennas: A review. 1978;66:1592-1618. DOI: 10.1109/PROC.1978.11170

[48] Şansal GT, Yazgan E, Afacan E. Determination of the radiation pattern of an array fed paraboloidal reflector antenna by using equivalent feed in 3-D. In: *NATO Symposium on Smart Antennas RTA*; 7-10 April 2003; Chester, United Kingdom. 2003

[49] Rusch WVT. An equivalent focused reflector feed in place of any generalized defocused or extended feed. *Electronics Letters*. 1978;14:5-6. DOI: 10.1049/el:19780004

[50] Yazgan E, Şansal GT. Three-dimensional equivalent focused feed for an offset paraboloidal reflector antenna. *Electromagnetics*. 2004;24:597-605. DOI: 10.1080/02726340490513329

[51] Rusch WVT, Prata A, Rahmat-Samii Y, Shore R. Derivation and application of the equivalent paraboloid for classical offset Cassegrain and Gregorian antennas. *IEEE Transactions on Antennas and Propagation*. 1990;**38**:1141-1149. DOI: 10.1109/8.56949

[52] Turgut G, Yazgan E. Analysis of the asymmetric dual reflector antenna systems by using equivalent feed and antenna concepts. In: *ELECO 2017*; 30 Nov.-2 Dec. 2017; Bursa, Turkey. 2017

[53] Turgut G, Yazgan E. Application of equivalent paraboloid antenna and equivalent feed methods for off-focus fed dual asymmetric reflectors. *Journal of Faculty of Engineering and Architecture of Gazi University*. 2019;**34**:1929-1938. DOI: 10.17341/gazimmfd.571637 (in Turkish)

[54] Olea A, Montesano A, Montesano C, Arenas S. X-band high gain antenna qualified for Mars atmosphere. In: *Proceedings of the Fourth European Conference on Antennas and Propagation*; 12-16 April 2010; Barcelona, Spain. 2010

[55] Hodges RE, Chahat N, Hoppe DJ, Vacchione JD. A deployable high-gain antenna bound for Mars: Developing a new folded-panel reflectarray for the first CubeSat mission to Mars. *IEEE Antennas and Propagation Magazine*. 2017;**59**:39-49. DOI: 10.1109/MAP.2017.2655561

[56] Akan V et al. Technical Report for Research Project: YADAS, 7I150800-MASG-RPR-2017007-01. Ankara, Turkey: TUBITAK Space Technologies Research Institute; June 2017 (in Turkish)