

# SERIES

alpine space – man & environment: vol. 7

Series Editors: Roland Psenner, Reinhard Lackner, Axel Borsdorf





COST is supported by the EU  
RTD Framework programme



ESF provides the COST Office  
through an EC contract



This publication is supported by COST.

The legal notice by COST Office:

Neither the COST Office nor any person acting on its behalf is responsible for the use which might be made of the information contained in this publication.

The COST Office is not responsible for the external websites referred to in this publication.

© *innsbruck* university press, 2009

University of Innsbruck, Vice-Rectorate for Research

1<sup>st</sup> edition.

All rights lie with the respective authors.

Coverdesign & photography: Gregor Sailer

Layout: Reinhard Lackner

Printed by Fred Steiner, Rinn

[www.uibk.ac.at/iup](http://www.uibk.ac.at/iup)

[www.uibk.ac.at/alpinerraum/publications/](http://www.uibk.ac.at/alpinerraum/publications/)

ISBN 978-3-902571-97-7

Robert Jandl, Axel Borsdorf, Helga Van Miegroet,  
Reinhard Lackner, Roland Psenner (Eds.)

**Global Change and Sustainable  
Development in Mountain Regions**  
**COST Strategic Workshop**



## Inhalt

### Introduction

*Axel Borsdorf*

Mountain Waters in a Changing World ..... 11

*Rolf Weingartner, Daniel Viviroli, Greg Greenwood*

Mountain Vegetation under Environmental Change ..... 25

*Christian Körner*

Is there a Future for Mountain Forestry? ..... 31

*Dieter Stöhr*

Mountain Tourism in a Climate of Change ..... 39

*Philippe Bourdeau*

Natural Disasters and Climate Change in the Alps ..... 53

*Gerhard Berz*

Supply and Demand for Ecosystem Services in Mountainous Regions..... 61

*Thomas Koellner*

Global Changes and Economic Globalization in the Andes.

Challenges for Developing Nations ..... 71

*Hugo I. Romero, Pamela Smith and Alexis Vasquez*

Land Use Change in the Northern Carpathians ..... 93

*Jacek Kozak*

The Past and Future of Rocky Mountain Forests: Connecting People and Ecology ... 97

*Dan Binkley*

Transfer of Forestry Expertise Between Mountain Regions ..... 103

*Robert Jandl, Helga Van Miegroet, Alexander Ač and Radek Pokorný*

Global Change and Sustainable Development in Mountain Regions –

The Pacific Northwest Region of North America ..... 115

*Paul Mitchell-Banks*

Optimizing a Monitoring Network for Assessing Ambient Air Quality

in the Athabasca Oil Sands Region of Alberta, Canada ..... 127

*Włod Frączek, Andrzej Bytnerowicz and Allan Legge*

The New Era has Begun: Renewable Bioenergy Production as

a Progressing Interdisciplinary Research Approach ..... 143

*Yolina Hubenova, Mario Mitov*



# Global Change and Sustainable Development in Mountain Regions

## An Introduction to the Proceedings of the Conference

Axel Borsdorf, Innsbruck and Robert Jandl, Vienna

COST supports strategic workshops in order to provide the participants an opportunity to identified future research needs. The Strategic Workshop „Global Change and Sustainable Development in Mountain Regions” was convened at the Congress Hall of Innsbruck, Austria, from April 7-9, 2008. The event attracted more than 350 scientists, experts, practitioners, students, and scholars from 29 European and 10 non-European countries. It was based on three pillars ‘keynotes’, ‘discussion groups’, and ‘presentations of ongoing projects’. The keynotes were presented by leading experts in their specific field and addressed current key research questions. The format of the discussion groups ensured that every participant could articulate his experiences and ideas. The project presentations gave an overview on ongoing activities, and were used as networking opportunities.

### *COST*

COST – the acronym for European Cooperation in Science and Technology – is the oldest and widest European intergovernmental network for cooperation in research. Established by the Ministerial Conference in November 1971, COST is presently used by the scientific communities of 35 European countries to cooperate in common research projects supported by national funds.

The funds provided by COST – less than 1% of the total value of the projects – support the COST cooperation networks (COST Actions) through which, with EUR 30 million per year, more than 30000 European scientists are involved in research having a total value which exceeds EUR 2 billion per year. This is the financial worth of the European added value which COST achieves.

A “bottom up approach” (the initiative of launching a COST Action comes from the European scientists themselves), “à la carte participation” (only countries interested in the Action participate), “equality of access” (participation is open also to the scientific communities of countries not belonging to the European Union) and

“flexible structure” (easy implementation and light management of the research initiatives) are the main characteristics of COST.

As precursor of advanced multidisciplinary research COST has a very important role for the realization of the European Research Area (ERA) anticipating and complementing the activities of the Framework Programmes, constituting a “bridge” towards the scientific communities of emerging countries, increasing the mobility of researchers across Europe and fostering the establishment of “Networks of Excellence” in many key scientific domains such as: Biomedicine and Molecular Biosciences; Food and Agriculture; Forests, their Products and Services; Materials, Physical and Nanosciences; Chemistry and Molecular Sciences and Technologies; Earth System Science and Environmental Management; Information and Communication Technologies; Transport and Urban Development; Individuals, Societies, Cultures and Health. It covers basic and more applied research and also addresses issues of pre-normative nature or of societal importance.

(Web: <http://www.cost.esf.org>)

### *Background*

The **central focus** of the Strategic Workshop was **sustainable development in European mountain regions**, i.e. generating economic wealth in mountain regions without eroding their natural and social capital. This focus was addressed with respect to a variety of cross-thematic issues – climate change, biodiversity, demographic change, land-use change, tourism, water, transport, science-policy interface – whose occurrence in mountain regions is of key importance in the European context; as well as a fifth issue: earth observation, an essential means of identifying occurrences of natural hazards and changes in land covers in these dynamic regions (European Commission, 2004: Mountain areas in Europe: analysis of mountain areas in EU Member States, acceding and other European countries; European Topic Centre for Land Use and Spatial Information, 2008: Integrated assessment of Europe’s mountain areas, internal report, ETC-LUSI, Barcelona).

The Workshop focused on mountain regions for the following reasons:

- Mountains cover a significant proportion (29%) of the area of the European Union, and are home to 18% of its population.
- Mountain regions are not just rural areas, but also include many urban areas.



They share a range of natural and economic handicaps:

- Many mountain areas suffer high unemployment rates (Balkan, Southern Spain, Scotland, South Italy, Carpathians: 10-55 % above national average).
- Many mountain regions suffer demographic loss and aging (Carpathians, Southern Alps, Galicia, Balkans, Apennines, parts of the Scandes: decrease rate > 2% per year).
- Most mountains are remote areas with poor accessibility (more than 30 km to the next highway).
- Thus mountain areas are often peripheral regions, 'islands' in their national and international contexts.

On the other hand, mountains provide key resources to Europe:

- Mountains are European centres of both biological and cultural diversity, often arising jointly through centuries of landscape management and modification.
- Mountain regions are important current and potential sources of renewable energy, particularly hydro-electricity, but also wind, biomass, and solar.
- Mountains provide diverse important goods and services to Europe as a whole, including water, tourism, and mitigation of natural hazards.

Thus, while many of Europe's mountains are peripheral, all of them provide important resources to European populations. Yet, due to the diverse handicaps, mountain regions are frequently at risk of unsustainable development: extractive development that does not protect the natural or social capital of these regions. This challenge is exacerbated by climate change, to which mountain regions – especially the cryosphere – are especially sensitive (Price, M.F. 2008: Maintaining mountain biodiversity in an era of climate change. In: Borsdorf, A., J. Stötter and E. Veulliet (eds.) *Managing Alpine Future. Proceedings of International Conference October 15-17, 2007*: Vienna: 17-33), as development projects seldom consider the cumulative and synergistic impacts of development and climate change. This means that the continued provision of these many goods and services is uncertain: a key risk for Europe as a whole.

Mountain regions – their ecology, economy and society – are particularly sensitive to Global Change. These three pillars need to be in balance in order not to jeopardize the livelihood of future generations. Land use is affected by the interactions of processes relating to these three pillars. Vice versa, land use management can mitigate the adverse effects of global change (e.g., protective forests, slope stabilization). In the same vein, globalization is manifest in mountain areas, for instance, in depopulation in remote regions, restructuring of urban centres, and tourism.

In spite of the dramatic impacts of global change in mountain regions, it must be stated that international research programmes have not yet reflected the urgent need for investigation on the effects and on adaptive strategies to face the challenges and to implement measurements to ensure sustainability, life quality and stability in mountain regions. At least two international research strategies were outlined in the last year: The Research Agenda to the Multiannual Working Programme 2005-2010 of the Alpine Convention (worked out by ISCAR, the International Committee on Alpine Research), the GLOCHAMORE Research Strategy by the Mountain Research Initiative, Bern.

The attendance of representatives of global networks on mountain research, like FAO's Mountain Partnership (*Douglas McGuire*) and the Mountain Forum (*Martin Price*) demonstrated the international attention the conference arose. The presence of leading national, regional and local politicians (Governor of Tyrol, *Hervig van Staa*, Vice Mayor of Innsbruck, *Eugen Sprenger*, as well as a Representative of the Austrian Minister for Agriculture, *Hubert Siegel*) also demonstrated the interest of policy makers in the results of the conference. The most important organizations responsible for alpine sustainable development like CIPRA, ALPARC, Alliance of the Alps, Club Arc Alpin and others may be seen as an indicator for the weight of the COST Strategic Workshop and also indicates that the conference really reached the stakeholders responsible for mountain sustainable development.

Until today the international research funding organizations could only partially fulfil the expectations of the scientists. It must also be stated, that the Interreg IVb Programme Alpine Space changed the objectives and funding strategy towards application and implementation of the first campaign, so that new and innovative research can no longer be financed by this programme. Scientists all over the world are convinced that new research is an urgent need, as there are still many questions open, and strategies without a sufficient theoretical framework will fail.

### *Objectives*

Against this background the Strategic Workshop aimed at putting research topics on mountain ecosystem services on the political agenda and identifying the implications of climate and socio-economic change for current and future forms of land use. The workshop assessed impacts on selected ecosystem services such as hazard protection, recreation, and natural resources.

Furthermore, scenarios of change and their implications for societies depending on these ecosystem services were appraised. In addition to the Alps, other mountain systems were also considered.

### *Relation to Policy*

The Strategic Workshop had a significant European dimension. Most European mountain regions cross multiple national boundaries. Solutions for sustainable development of these regions require action at a European level.

International cooperation is essential for sustainable development in mountain regions, as these regions face similar challenges and will profit from experiences in other mountain ranges. The COST Strategic Workshop is consistent with the EU Sustainable Development Strategy 2006 (SDS; see [http://ec.europa.eu/sustainable/sds2006/index\\_en.htm](http://ec.europa.eu/sustainable/sds2006/index_en.htm)). This strategy states that the participation of citizens in decision-making should be enhanced, and education and public awareness relating to sustainable development should be promoted. Citizens should be informed regarding their impact on the environment and their options for making more sustainable choices.

In accordance to the SDS, the workshop strived for detecting, identifying and conceptualizing knowledge deriving from research in order to foster proactive relationships between researchers and practitioners and enhance sustainable development in European mountain regions.

The Workshop was also designed in accordance to the European Spatial Development Perspective (European Commission, Luxembourg 1999). It aims for balanced and sustainable development, and specifically mentions mountains as a specific spatial unit. The conference can also be seen in relation with the current debate on the future of cohesion policy and territorial cohesion, debate in which mountains are regarded as territories with specific potential and specific handicaps needing adequate and tailored response. Thus the workshop intended to encourage practitioners to base their solutions on a research-based strategy presented by leading researchers in mountain regions from all over the globe.

A further effort of the workshop was to encourage international and national research funding institutions to focus more on mountain issues. Mountain regions provide ecosystem services (water, energy, fresh air, biodiversity, mineral resources, recreation) for millions of Europeans, who live in the lowlands. It is hard to under-

stand, why other areas like coastal regions, deserts and industrial regions are dedicated to receive specific programmes, and not mountains.

The research needs were formulated during the workshop as follows:

The research needs were formulated for the following key topics of global change and sustainable development in mountain regions:

### ***Climate change***

Monitoring of climate change, development of locally valid climate scenarios, using appropriate downscaling instruments. As climate change affects natural hazards, adaptation strategies must be developed.

### ***Demographic change***

As demographic changes (aging, migration, household changes etc.) are very obvious and may be regarded as a second key driver of change in mountain regions. Depopulation and marginalization of remote areas cause many problems for ecology, economy and social coherence.

### ***Land-use change***

The desired sustainable land use requires updated concepts for land management. Research on land management and ecosystem services is a central need.

### ***Tourism***

Tourism in mountain areas is affected by climate and demographic change and other effects of globalization (new destinations, growing mobility, and new target groups). There are positive and negative effects. Research on new concepts and adaptive strategies are a strong need. Tourism in mountain regions is strongly connected to the ecology and to traditional forms of land use. Therefore climate and land use change are decisive for the development of this sector.

### ***Water***

Water is a central ecosystem service. As with the climate change and the effects of socio-economic globalization the demand will rise, but production will slow down, adaptive strategies are to be found. This also deals with juridical, ownership and governance questions.

### ***Transport***

The rising transport originate problems for the Alps. Other mountains lack by accessibility. This is why transport and transit questions have to be investigated in the regional context.

*International comparison*

The Alps are the best investigated mountain region. The relevant Experiences and results can serve as an excellent base for comparative studies.

*Science-policy interface*

Research is no longer to be done in an ivory tower. A strong theory-practice compound is as well a need as a well functioning interface with policy.

As the participants had different disciplinary backgrounds and came from almost all mountain regions of the world, the discussions demonstrated very clearly, that future research must be designed in an interdisciplinary manner, as mountains are very complex systems. Furthermore it became very clear, that stage and problems of the different mountain regions are not similar. Therefore the strategies to face the global change must be defined within the local or regional context.

*Success*

One year after the Innsbruck Strategic Workshop it can be stated that the conference had a strong impact. New project proposals were elaborated on the base of the workshop's results (such as mountain.TRIP and AAP [FP7]).

Researchers and practitioners formed new networks or were integrated to existing networks (like Mountain Partnership, Mountain Forum, Mountain Research Initiative). A concrete result was the formation of a research network for the Carpathian "Science for the Carpathians: S4C" right on the conference. Since than this group is the most important driving force of research in the Carpathian in strong relationship to the Carpathian Convention.

Mountain research as a whole was strengthened, and institutions received more money, staff or research infrastructure. The most important success factor can be measured by the manifold new personal contacts and even friendships in the scientific community and between researchers and practitioners, who since then found a new base of communication and exchange. The first result was the Innsbruck Memorandum, which was commonly formulated and unanimously accepted by all participants of the conference.

### **Innsbruck Memorandum**

The more than 350 participants of the COST Strategic Workshop on Global Change and Sustainable Development in Mountain Regions, leading scientists, practitioners, stakeholders and decision makers are...

... aware of the enormous scientific expertise and human capital available in mountain regions,

... convinced that this capital must be invaluating to timely respond to the challenges of global change (climate, demographic, economic, social, political and cultural) in mountain regions,

... emphasizing that global change will have much stronger impacts on mountain than on lowland regions,

... highlighting the importance of the mountains for protection against natural hazards, as providers of water, renewable energy, and other natural resources, recreation and touristic amenities for the lowlands.

The participants request the responsible in the European and International Bodies, in Research, Political and Economical Programmes, in National and Regional Corporations and Institutions to initiate, facilitate and expand their programmes and research strategies for mountain science to secure sustainable development under global change in mountain regions. The participants of the conference are convinced that this would not only sustain people's livelihoods in mountains but also in the adjacent lowlands.

### *Final remarks to the Conference and acknowledgments*

It was impressive to see the enormous progress of mountain related research not only in the Alps but in all mountain ranges. Not only the state-of-the-art was presented by the keynote speakers, they also identified priority research questions for future. It became clear that there is a large human capital and research experience, which can be in-valuated to address/solve the problems of global change and to implement strategies for sustainable development in mountain regions.

Any conference has side-effects: Networking, contact-making, exchange of plans, visions, and project ideas. For this conference the informal scientific exchange was considered to be determinant for the success. Coffee breaks, lunch times, workshops and the poster session provided the platform for these informal encounters. We got the impression that we reached our goals in this aspect.

We would like to thank COST for its considerable support in the organisation of this conference, particularly the President of the Committee of Senior Officials Prof. Francesco Fedi, the Director of the COST Office Dr. Martin Grabert and the organising team from the COST Office, Senior Science Officer Günter Siegel and Ms. Svetlana Voinova. Furthermore, to the Scientific Committee of the Conference (Astrid Bjørnsen MRI; Roland Psenner, LFU; Thomas Scheurer, ISCAR; Ulrike Tappeiner, EURAC), to the conference helpers of the Mountain Research Institute IGF of the Austrian Academy of Sciences, especially Kati Heinrich and Sigrun Kanitscheider; to the realization of a web-cast by Astrid Bjørnsen, which was a key factor for the dissemination of the results in the virtual web; to all keynote speakers, workshop chairs and participants in the discussions; to all presenters of posters on the Mountain Research Market Place, and to the Congress Innsbruck, the Federal State of Tyrol and the Ministry for Agriculture, Forest, Environment and Water Management, which contributed to the realization of this conference.

### *The publication of the conference proceedings*

A conference is a single event, and in many cases, when time goes on, the results may be less and less acknowledged. The web-cast, which presents not only videos of all presentations but also the illustrating material, is a quite innovative method not only to disseminate the results immediately to all mountain researchers and practitioners all over the world but also to provide the results even for those, who could not attend the workshop. However, the organizers furthermore decided to look for a more traditional method to provide the findings for future research: the publication of this book. It presents the main topics of the conference, the key notes and speeches, and the findings of the many intensive workshops. The editors are convinced that these will enhance all kind of necessary research in mountain regions on a global, national, regional or local scale.

The book is structured in accordance to the conference agenda. In 13 chapters it presents contributions to basic research, to socio-economic topics and regional studies. The risks related to climate change are also addressed as water issues, high elevation ecosystems and monitoring methods. Forestry, tourism and ecosystem services of mountains are most important to evaluate the economy and the output of mountain systems. Mountains all over the world are challenged by global change. This is illustrated by regional examples of the Carpathians, the Andes, the Rocky

Mountains and the Pacific North West of Canada. Well known authors in the scientific community and high ranking practitioners, like Gerhard Berz (Germany), Dan Binkley (U.S.A.), Philippe Bourdeau (France), Witold Fraczek (USA), Yolina Hubenova (Bulgaria), Thomas Köllner (Switzerland), Christian Körner (Switzerland), Jacek Kozak (Poland), Paul Mitchell-Banks (Canada), Hugo Romero (Chile), Dieter Stöhr (Austria), and Rolf Weingartner (Switzerland) contribute to this issue. A complete overview on all contributions and the results of the workshops are published in Jandl, R., A. Borsdorf & G. Siegel 2008: Global Change and Sustainable Development in Mountain Regions. Executive Summary. Recommendations for Research. (ed. by M. Khorchidi & M. Price). Wien, Brüssel.

This publication is supported by COST. The editors appreciate very much the support of the COST Office. They also want to thank the publisher, Innsbruck University Press, and the Vice Rector for Research of the Innsbruck University, Tilmann Märk, for their permanent encouragement of the publication. It was a good experience to realize the support of the editors of the series “Alpine Research: Man and Environment” to the publication. It was Reinhard Lackner, who made the final redaction and perfect layout of the book whom we want to thank wholeheartedly for all his efforts.

It is a common human experience, that joint ventures may create good friendships. For us, one of the striking effects of the cooperation organizing the conference and publishing the proceedings is the foundation of a deep friendship of the editors of this book. We are convinced, that the workshop not only will lead to more joint activities in our case, but also for common efforts of those participants who found new friends in those days or deepened their existing friendships.

Axel Borsdorf  
Institute of Mountain Research: Man  
and Environment (IGF),  
Austrian Academy of Sciences (ÖAW)

Robert Jandl  
Federal Research and Training Centre  
for Forests, Natural Hazards and  
Landscape (BFW)





# Mountain Waters in a Changing World

Rolf Weingartner<sup>1)</sup>, Daniel Viviroli<sup>1)</sup>, Greg Greenwood<sup>2)</sup>

<sup>1)</sup> Group of Hydrology at the Institute of Geography, University of Bern (Switzerland)

<sup>2)</sup> Mountain Research Initiative (MRI) at the Institute of Geography, University of Bern (Switzerland)

## *1) Introduction*

The Inn River just outside the Conference hall in Innsbruck exhibits a typical alpine river regime with low water conditions during winter and high flow during spring and summer due to snow and ice melt (cf. Figure 4). This regime results from an interaction of different factors: the alpine climate including precipitation, temperature and especially snow and ice, the alpine ecosystem with topography, soils, and vegetation, and human activities with hydropower production as the most important. Global change has and will alter all of these factors. Do we already see any changes in the hydrological system? Have the water balance of alpine basins and the runoff conditions already changed? What do we know about the hydrological cycle in mountains in the future? Does hydrological research in mountain areas focus on the right questions?

This paper, which provides an overview of a talk given at the COST strategic workshop in Innsbruck in April 2008, discusses these questions with a special focus on the Swiss Alps.

## *2) The significance of mountain waters*

If someone asked a hydrologist to illustrate the basic features of mountain hydrology with only one figure, the result would be something like that shown in Figure 1. It depicts the gradients, i.e. the changes of precipitation, evapotranspiration and runoff with altitude.

Runoff increases with altitude as a result of the gradients of precipitation (approx. 0.7 mm/a per meter in altitude in the northern part of the Alps; Schädler and Weingartner 2002) and evapotranspiration (approx. - 0.2 mm/a per m; Menzel et al. 1999). We have to bear in mind, however, that the spatial variability of these gradients is

## Global Change and Sustainable Development in Mountain Regions

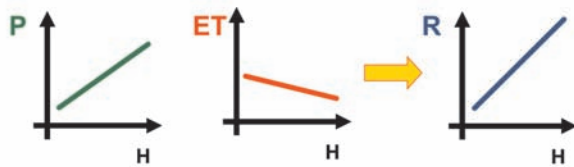

$$R(H) = P(H_0) + a \cdot \delta H - (ET(H_0) + b \cdot \delta H) = P(H_0) - ET(H_0) + \delta H(a - b)$$

$R(H)$ : annual runoff [mm/a] at altitude  $H$  [m asl.]

$P(H_0)$ : annual precipitation [mm/a] at basic altitude  $H_0$  [m asl.]

$ET(H_0)$ : annual evapotranspiration [mm/a] at basic altitude ( $H_0$ ) [m asl.]

$H$ : altitude [m asl.]

$a$ : gradient of precipitation [mm/m]

$b$ : gradient of evapotranspiration (usually negative) [mm/a]

$\delta H$ : difference in altitude between  $H$  and basic altitude  $H_0$  [H]

*Fig. 1: Gradients of precipitation (P), evapotranspiration (ET) and – as a result – of runoff (R)*

considerable (Schädler and Weingartner 2002) which means that local and regional gradients may differ considerably from the figures given in the last sentence. This elevationally dependent rise of annual runoff is the main reason why mountains could be entitled “water towers”. The abundance of runoff in mountain areas can also be demonstrated by a comparison of the water balance of the Alps and of the whole of Europe (Table 1). Due to much greater precipitation, runoff in the Alps is as much as three to four times higher than that in the rest of Europe.

*Table 1: Long-term mean water balance of the Alps and of Europe*

[mm/a]	Alps	Europe
Precipitation	1450	657
Evapotranspiration	535	375
Runoff	915	282
Source	<i>Baumgartner et al. (1983)</i>	<i>Baumgartner and Reichel (1975)</i>

These figures emphasize the role of the European Alps as the water tower of Europe. This also means that the adjacent lowlands profit from the alpine water resources. For the Rhine River, for example, the alpine region contributes about 34% to total runoff in the Netherlands, although the respective catchment area comprises only 15% of the total watershed (Viviroli and Weingartner 2004). The adjacent lowlands especially profit from the abundance of water during the lowland dry season in

spring and summer as the major rivers like the Inn, the Rhine, the Po and the Rhone transport water originating from snow and ice melt.

This leads us to the question of the role of world's mountains for the supply of Earth's land surface with blue water (i.e. river runoff). Viviroli et al. (2007) assessed the significance of world's mountain regions for the lowland water resources with a spatial resolution of  $0.5^\circ$  (approx.  $50 \text{ km} \times 50 \text{ km}$ ). They showed that mountains and hills outside of the humid tropics cover only 40% of total land surface but produce as much as 56% of total runoff. In the arid zones where mountains are almost the only source of water, the contribution of mountains increases to about 70% of total runoff (cf. Figure 6), thereby reducing the variability of supply.

### *3) A changing mountain water world*

In this paper, we use two different perspectives to look at global change. The retrospective view focuses on instrumental records over the last decades and uses time series analyses to detect changes. The prospective view tries to estimate possible developments by combining climate change scenarios and hydrological models.

We explore five working hypotheses under these two perspectives. These hypotheses are not exhaustive, but rather illustrate the problem at different spatial and temporal scales. These hypotheses are used primarily to demonstrate possible influences of climate change on the hydrological system in mountainous areas.

#### **Hypothesis 1 (retrospective): The water balance of alpine catchments has not yet changed significantly.**

To explore this hypothesis, we analyse the time series of the large river basins of Switzerland, i.e. of the Rhine River at Basel (northern part of Switzerland), of the Ticino River at Bellinzona (southern part of Switzerland) and of the Inn River at Martina (inner alpine zone). These series cover the period 1901-2000 (Figure 2).

In the Rhine River catchment, precipitation (P) has increased by about 100 mm in total between 1901 and 2000. Most of this change is due to higher winter precipitation which has increased over the 20<sup>th</sup> century by 20% to 30% in the northern part of the Alps (OcCC 2007). In the same period, evapotranspiration (ET) has increased by a similar amount due to global warming (temperature increase in Switzerland between 1901 and 2000: 1.3 to 1.6 °C in the northern part, 1.0 °C in the southern part (OcCC 2007)). As a result, no change occurred in runoff (R) because R equals P minus ET (cf. Figure 2).









Rhine 1901-2000 (northern Alpine)	Ticino 1901-2000 (southern Alpine)	Inn 1901-2000 (inner Alpine)
<b>Precipitation (P)</b>  +118 mm/100a P = 1404 mm/a (mean 1901-2000)	 -22 mm/100a P = 1829 mm/a	 -11 mm/100a P = 1215 mm/a
<b>Evapotranspiration (ET)</b>  +107 mm/100a ET = 461 mm/a	 +192 mm/100a ET = 411 mm/a	 +15 mm/100a ET = 302 mm/a
<b>Runoff (R = P - ET - dS)</b>  +7 mm/100a R = 949 mm/a (dS = -6 mm/a)	 -218 mm/100a R = 1421 mm/a (dS = -3 mm/a)	 -42 mm/100a R = 928 mm/a (dS = -15 mm/a)

Fig. 2: Change in water balance for the selected river basins of Switzerland (based on data from Schädler and Weingartner 2007); dS: change in storage (especially glaciers); red arrows: statistically significant trends ( $\alpha = 5\%$ )

The situation is totally different for the Ticino River. Here we find a significant decrease in runoff due to a significant increase in evapotranspiration, with just a slight decline in precipitation.

Both the northern alpine Rhine River and southern alpine Ticino River differ from the inner alpine Inn River which shows yet another behavior with almost no change in precipitation, evapotranspiration and a slight change in runoff over the last century.

We conclude from these examples that

- changes in the large alpine river basins are not yet dramatic, as precipitation, the main driver of the hydrological system, seems to be quite stable, especially in the inner alpine region as well as in the southern part of Switzerland,
- runoff in the southern part of the Alps seems to be affected the most and
- we are currently at a critical point, i.e. we must assume that the changes in the alpine hydrological system will increase in the light of the future climate characterized by less precipitation and warmer temperatures (cf. OcCC 2007).

We have shown above that the rise in winter precipitation is significant in the northern part of Switzerland. This leads us to the second hypothesis:

**Hypothesis 2 (retrospective): The low flow conditions in winter are affected the most, especially in the middle and lower parts of the Alps.**

We select the Rhine River at Basel to explore this hypothesis. This river drains almost all of northern Switzerland (area approx. 36'000 km<sup>2</sup>). The runoff regime of the Rhine includes low flow in winter and high flow during spring and summer. Hypothesis 2 focuses on winter low flows characterized here by the annual lowest mean over 7 days (AM7).

Figure 3 suggests that low flows during winter have increased since 1871. Pfister et al. (2006) found two main reasons for this change:

- 1) Man-made: Mainly since 1945, a considerable volume of water is stored in alpine reservoirs within the Upper Rhine basin (1945: approx. 0.5 km<sup>3</sup>, today: 1.6 km<sup>3</sup>). These reservoirs are usually filled over the course of the summer half-year. During the winter half-year, they are gradually emptied for power generation, which increases discharge. At present, the estimated mean rise in winter discharge at Basel due to power generation is between 70 and 80 m<sup>3</sup> s<sup>-1</sup> (cf. "AM7 simulated 'power stations'" in Figure 3). Prior to World War II, the increase in winter discharge was correspondingly less. As it can be seen from Figure 3, a considerable proportion of the rise in AM7 during the 20<sup>th</sup> century can be attributed to hydropower generation. Other man-made factors (e.g. the correction of the Jura Waters, 1868-1991 and 1962-1973), which lowered the water levels of the three lakes in the western

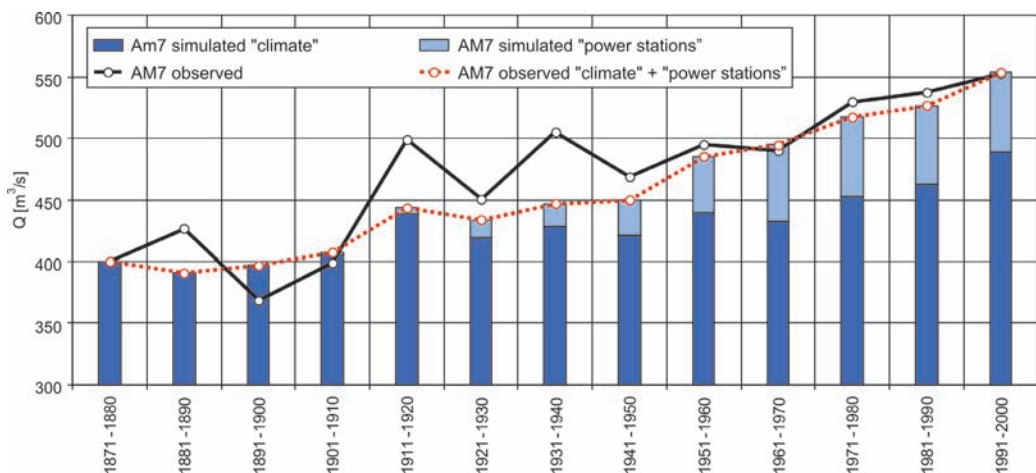

Figure 3: Rhine at Basel: observed and simulated AM7 values (10-year means) from 1871 to 2000 (Pfister et al. 2006)

Swiss Plateau to a common level (Vischer and Feldmann, 2005), may affect low flow, but their influence is far less significant because the size of their watershed is but a small fraction of the total (Breinlinger et al. 1992).

- 2) Climate change: In order to determine the influence of climate change on AM7 values, a regression model was calibrated in the period 1869-1910. During this time, the influence of hydro-electric power stations was minimal (Pfister et al. 2006). This model then was applied to the period 1910 onwards to simulate the low flow of the Rhine using climate data as input parameters. The result in Figure 3 (Am7 simulated “climate”) shows that climatic change, i.e. warmer and wetter winters, indeed promoted an increase in low water discharge, in particular during the second half of the 20<sup>th</sup> century (see Widmann and Schär 1997; Begert et al. 2005). The warmth of the winters also increased the proportion of the precipitation occurring as rain instead of snow.

### **Hypothesis 3 (retrospective): Extreme floods, which normally occur during summer, have increased.**

At first glance, there is no clear answer to this hypothesis! A comparison of flood time series of Swiss alpine mesoscale catchments shows a quite heterogeneous picture (Diezig et al. (in prep.)): For some rivers (but not the majority!) the magnitude of floods has increased significantly, whereas in others, it has not. However, most of the time series investigated show a tendency of increasing floods. This uniform signal can be interpreted as an indicator that flood risk will likely increase in the near future.

The reaction of a catchment to heavy rainfall events depends strongly on the dominant processes in runoff generation. Some rivers are more sensitive to a change in rainfall intensity (e.g. the Allenbach at Adelboden), while others are sensitive to a change in the amount of rainfall occurring over 2 to 3 days (e.g. the Saltina at Brig; Naef et al. 1999). Furthermore, processes of flood generation may change dramatically when a certain threshold value (e.g. rainfall intensity) is reached because they are non-linear (Naef et al. 2008).

But there is also another remarkable fact that influences the flood behavior of a catchment: flood cycles, i.e. periods with a higher frequency of floods followed by a period with a lower frequency (Pfister 1999 and Naef 2006). The origin of these cycles is still unclear. Only a few indications of possible reasons can be found in the literature (e.g. Benito et al. 2003). Sturm et al. (2001), for example, postulate a connection with changes in the atmospheric circulation pattern.

According to Naef (2006), periods with high frequency of floods occurred in Switzerland at the beginning of the 17<sup>th</sup> century, in the late 18<sup>th</sup> century, and between 1850 and 1910. It seems that we are now entering a new “high frequency period”. Does this mean that both climate change and flood cycle are overlapping or will overlap within the next years or even decades? If so, this could have an enormous impact on flood hydrology!

The next two hypotheses look into the future:

**Hypothesis 4 (prospective): Snow cover, not glaciers, is the key factor for understanding future runoff conditions.**

Snow and ice melt are the most important driving factors of alpine river regimes (Figure 4). Snow melt strongly influences the mean monthly flows in May and June, while ice melt influences the flows between July and September. A classification of Swiss alpine river regimes can be based on the order of mean monthly flows between May and September (Weingartner and Aschwanden 1992): A characteristic ordering of a snow melt driven regime (so-called nival regime) is June > May > July > August, i.e. the highest mean flows occur in June, the second-highest in May, and so on. A typical ordering for a glacial regime is July > August > June > September.

Changes in snow cover as well as in the extent of glaciers will influence the seasonal runoff pattern. There is, however, a big difference between these two driving factors: The influence of glaciers on runoff strongly depends on the portion of a catchment covered by glaciers. In highly glaciated catchments, the expected disappearance of the glaciers (OcCC 2007) will alter runoff during the summer months. However, snow cover is the most important factor in all catchments because of its large spatial extent. For instance, a modelling experiment by Zappa et al. (2003) in the Dischma river in the Grisons (mean altitude: 2378 m asl., glaciated area: 2.1%) showed that snow melt accounts for as much as 80% of total runoff.

Horton et al. (2005) simulated the runoff of the alpine river Weisse Lütschine (mean altitude: 2170 m asl., glaciated area: 17.6%) in a warmer climate (Figure 5). Due to the disappearance of glaciers, summer flows will decline significantly. Furthermore, the contribution of snow melt will decrease due to a higher snow line and less snow-covered area. On the other hand, winter flows will increase (cf. hypothesis 2). Horton’s simulation illustrates, however, that this increase in winter runoff will not compensate for the decrease of spring and summer flows, which means that on the whole, annual runoff will decline. As a consequence, hydropower production will

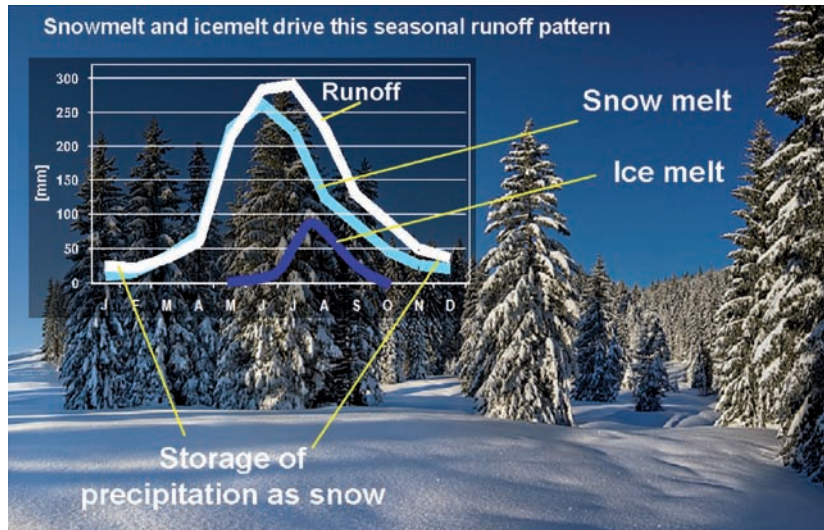

Fig. 4: A typical alpine river regime

also decline. A rough calculation by Piot (2005) gives a figure of -7% for the period 2020-2049 which seems not very dramatic. However, climate change will also alter the electricity market and the consumption pattern. According to OcCC (2007), the number of days during which electricity is needed to heat houses will decrease by 10 to 15%, whereas the number of days during which energy is needed to cool them during summer will at least double by 2050 compared to the period 1984 to 2004.

Climate change may also influence the year-to-year variability of river runoff. This variability is quite important from a water management perspective. A small year-to-year variability is favorable for the use of water because a similar amount of water can be expected almost every year. Due to decreasing influence of snow and ice melt, the year-to-year variability will increase in the future. The runoff pattern will be increasingly driven by rain.

Despite these changes, the Alps will remain the water tower of Europe; however, in large rivers like the Rhine, the supporting function of summer flows from the Alps will diminish (cf. Figure 5, right).



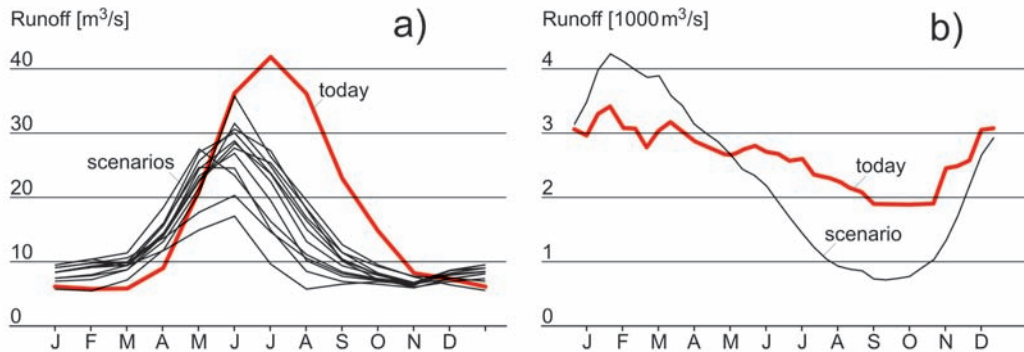

Fig. 5: a) River regime of River Weisse Lütschine (Bernese Oberland) today and in a warmer climate (depicted by several scenarios acc. Horton et al. 2005 ).

b) Regime of the Rhine River (Netherlands) today and in a warmer climate towards the end of the 21<sup>st</sup> century (acc. Lenderink et al. 2007).

With the last hypothesis, we shift to the global scale to address the future role of mountains:

**Hypothesis 5 (prospective): The pressure on mountain water resources will increase, especially in the semi-arid low latitudes.**

Figure 6 summarizes the hydrological significance of world's mountains. The larger the triangles, the more important are the mountains for the lowlands. The map underlines the important role of mountains for the water supply of the adjacent lowlands, particularly in the semi-arid low latitudes (cf. chapter 2).

Mountain water resources will be influenced by climate change. Changes in precipitation, snow cover patterns and glacier storage are likely to affect discharge with respect to timing, volume and variability and will influence runoff characteristics in the lowlands as well (cf. Figure 5, right). It must be noted, however, that the accuracy of current estimates is limited because of the uncertainty of regional climatic forecasts (Occc 2007).

Dramatic population growth in the semi-arid lowland areas, already prone to water scarcity today (cf. Viviroli et al. 2007), will exacerbate the situation in the future (Messerli et al. 2004) when combined with climate change. The effect will be the strongest in semi-arid regions and also the monsoon belts, especially when seasonal deficits occur, which until now have been attenuated by mountain water supply. This change will provoke the construction of dams for irrigation, but also

of canals to transfer mountain water to water scarce regions (e.g. the “Inter Basin Water Transfer link project of India”, cf. Jain et al. 2005). These measures are, in turn, expected to cause changes in runoff regimes with impacts on water availability and ecosystem health in the lowlands.

Population growth is also anticipated within the mountain regions themselves. According to FAO (2002), more than half of the mountain population in developing countries (in the range of 250 to 370 million people) are vulnerable to food insecurity (year 2000), and this despite of the fact that they are living in the water towers of the world where water for agriculture should be abundant. Traditional livelihood strategies are no longer sustainable in many places due to an intensification of land-use, which in turn leads to soil degradation, rapid deforestation, and erosion. Furthermore, some mountain countries with rich resources of water, e.g. Nepal, are even prone to so-called economic water stress. This phenomenon occurs when growing water demand faces an underdeveloped infrastructure caused by insufficient investment and exacerbated by a lack of human capacity (IWMI 2006).

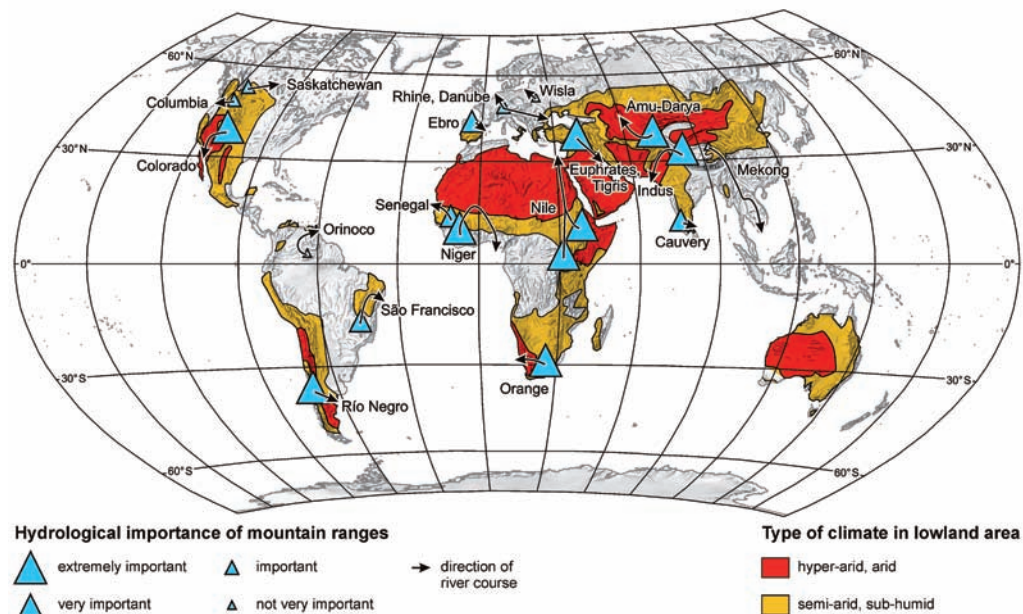

Fig. 6: Hydrological role of mountains (acc. Vivioli and Weingartner 2002)

#### 4) *Conclusion*

These five working hypotheses clearly demonstrate that mountain hydrology is changing. However, the picture that emerges is fragmentary and heterogeneous, a result of today's incomplete understanding. Therefore it is not surprising that several scientific programmes are starting right now to get a more quantitative understanding of possible changes in the alpine hydrological system. The Swiss project "CCHydro", initiated by the Federal Office for the Environment, is a good example. Starting in late 2008, several research groups in Switzerland will study the effect of climate change in a comprehensive way by using a common set of downscaled regional climate scenarios, thereby enabling a direct comparison of results during the synthesis of the project in 2011. The main problem faced by such a project is that climate change affects not only the input parameters like temperature and precipitation but also the hydrologically relevant catchment parameters like vegetation, soils etc. This is a serious interdisciplinary challenge as we can no longer afford to use the hydrological models calibrated on today's catchment parameters and merely change climate input parameters when we wish to project the impact of future climates. Changes in the catchment parameters are, however, non-linear, which means that system behavior is even more difficult to model and to understand.

Climate change research often faces a second problem. It is often disconnected from application and has little impact on daily practices or relevance to policy makers. Let us consider this point using an example of the Swiss Canton of Uri. In March 2008, the government of Uri organized a workshop entitled "Canton of Uri and the consequences of climate change – Science in dialogue with politics, economy and society" ([www.uri.info/files/?id=7120](http://www.uri.info/files/?id=7120)). This workshop demonstrates that the government of Uri has urgent questions concerning climate change and is trying to improve the dialogue between science and politics, economy and society. One of the important questions is the degree to which the flood protection measures valid for today's climate must be changed to mitigate the effects of climate change (Figure 7). The government expects to receive recommendations and strategies related to this question; but has science compiled the existing knowledge? There are reasonable doubts. First, the generation of locally useful data and understanding is often hampered by a lack of financing and time. In addition, the strong emphasis by universities on the generation of international peer-reviewed scientific papers tends to discourage the generation of such local data and understanding. Thus climate change research requires both peer reviewed papers and local data and understanding (NRC 2007).

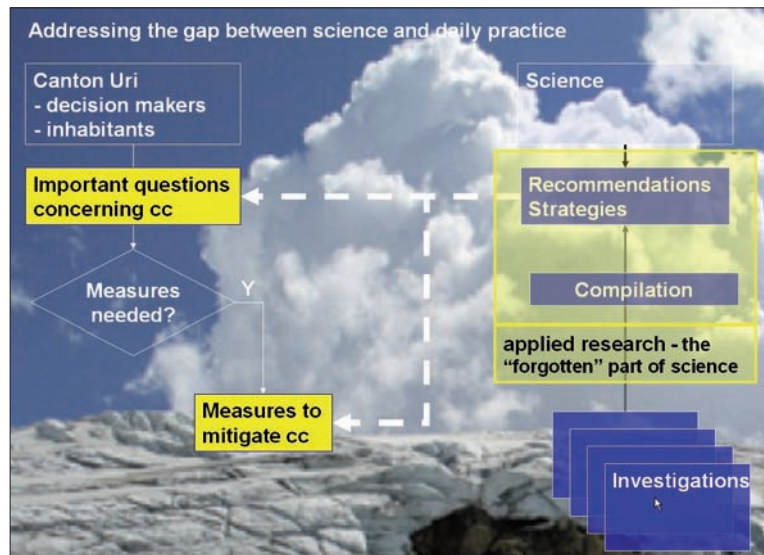

Fig. 7: Applied climate change research (example of Canton Uri)

This emphasis on practices leads to a final statement: In our research, we often focus exclusively on the effects of climate change in the distant future. We focus on the years 2050, 2070 and 2100 and tend to forget the current hydrological problems. There are already a lot of water problems on different scales, in the mountains as in the lowlands, in science as well as in daily practice. It is as important to solve these problems today as it is to understand how the hydrological cycle will change in the future.

### *Acknowledgment*

The authors thank Tom Reist (University of Bern) for comments and for the final editing.

### *References*

- Baumgartner, A., Reichel, E. (1975): Die Weltwasserbilanz. München.
- Baumgartner, A., Reichel, E., Weber, G. (1983): Der Wasserhaushalt der Alpen. München.
- Benito, G., Diez-Herrero, A., Fernandez de Villalta, M. (2003): Magnitude and frequency of flooding in the Tagus basin (Central Spain) over the last millennium. Climatic change 58:171-192.

- Begert, M., Schlegel, Th., Kirchhofer, W. (2005): Homogeneous temperature and precipitation series of Switzerland from 1864 to 2000. In: *International Journal of Climatology* 25:65-80.
- Breinlinger, R., Gamma, P., Weingartner, R. (1992): Kenngrößen kleiner Einzugsgebiete. *Hydrologischer Atlas der Schweiz*, Tafel 1.2, Bern.
- Diezig, R., Kan, C. et al. (in prep): Hochwasser. *Hydrologischer Atlas der Schweiz*, Bern.
- FAO (2002): Environment, poverty and Food insecurity – the vulnerability of mountain environments and populations. *FAO special feature*, 19 pp.
- Horton, P. et al. (2005): Prediction of climate change impacts on Alpine discharge regimes under A2 and B2 SRES emission scenarios for two future time periods. *Bundesamt für Energie*.
- IWMI [International Water Management Institute] (2006): Insights from the Comprehensive Assessment of Water Mangement in Agriculture. *Stockholm World Water Week 2006*.
- Jain, S.K., Reddy, N.S.R.K., Chaube, U.C. (2005): Analysis of a large inter-basin water transfer system in India. *Hydrological Sciences Journal* 50(1):125-137.
- Lenderink, G. et al. (2007): Estimates of Future Discharges of the River Rhine Using two Scenario Methodologies: Direct versus Delta Approach. *Hydrol. Earth. Syst. Sci.* 11(3):1145-1159.
- Menzel, L., Lang, H., Rohmann, M. (1999): Mittlere jährliche aktuelle Verdunstungshöhen 1973-1992. *Hydrologischer Atlas der Schweiz*, Tafel 4.1, Bern.
- Messerli, B., Viviroli, D., Weingartner, R. (2004): Mountains of the World: Vulnerable Water Towers for the 21<sup>st</sup> century. *AMBIO*, Special report 13:29-34.
- Naef, F. (2006): Extreme Hochwasser verstehen – Beispiel aus der Schweiz: In: Gutknecht, D. (ed.): *Extreme Abflussereignisse*, Wiener Mitteilungen Wasser-Abwasser-Gewässer, Band 206:59-68.
- Naef, F., Scherrer, S., Zurbrügg, CH. (1999): Grosse Hochwasser – unterschiedliche Reaktionen von Einzugsgebieten auf Starkregen. *Hydrologischer Atlas der Schweiz*, Tafel 5.7, Bern.
- Naef, F., Schmocker-Fackel, P., Margreth, M., Kienzler, P., Scherrer, S. (2008): Die Häufung der Hochwasser der letzten Jahre. In: *Ereignisanalyse Hochwasser 2005 – Teil 2* (in Druck).
- NRC [National Research Council] (2007): *Evaluating Progress of the U.S. Climate Change Science Program: Methods and Preliminary Results*. Washington, National Academies Press. 120 p
- OcCC (2007): *Klimaänderung und die Schweiz 2050 – Erwartete Auswirkungen auf Umwelt, Gesellschaft und Wirtschaft*. Bern.
- Pfister, Ch. (1999): *Wetternachhersage – 500 Jahre Klimavariationen und Naturkatastrophen*. Bern.
- Pfister, Ch., Weingartner, R., Luterbacher, J. (2006): Hydrological winter droughts over the last 450 years in the Upper Rhine basin: a methodological approach. *Journal of Hydrological Sciences*, Vol. 51, No. 5 (special issue: Historical hydrology):966-985.
- Piot, M. (2005): Auswirkungen der Klimaerwärmung auf die Wasserkraftproduktion in der Schweiz. In: *wasser, energie, luft*, 97, H. 11/12:365-367.
- Schädler, B., Weingartner, R. (2002): Ein detaillierter hydrologischer Blick auf die Wasserressourcen der Schweiz – Niederschlagskartierung im Gebirge als Herausforderung. *Wasser-Energie-Luft*, 94. Jg., Heft 7/8:189-197.
- Schädler, B., Weingartner, R. (2007): Impact of 20<sup>th</sup> Climate Change on Water Resources in Mountainous Regions of Switzerland. *Proceedings of the “The Third International Conference on Climate and Water*, 3-6 September 2007, Helsinki ([www.environment.fi](http://www.environment.fi)): 412-416, Helsinki.
- Sturm, K. et al. (2001): Hochwasser in Mitteleuropa seit 1500 und ihre Beziehung zur atmosphärischen Zirkulation. *Petermanns Geographische Mitteilungen* 145:14-23.

## Global Change and Sustainable Development in Mountain Regions

- Vischer, D., Feldmann H.U. (2005): The first correction of the Jura waters, 1868-1891. *Cartographica Helvetica* 32:17-32.
- Viviroli, D., Weingartner, R. (2002): Mountains: Sources of the World's Fresh Water. *GAIA* 11, Nr. 3:182-186.
- Viviroli, D., Weingartner, R. (2004): Hydrologische Bedeutung des europäischen Alpenraums. *Hydrologischer Atlas der Schweiz*, Tafel 6.4, Bern.
- Viviroli, D., H. H. Dürr, B. Messerli, M. Meybeck, and R. Weingartner (2007): Mountains of the world, water towers for humanity: Typology, mapping, and global significance, *Water Resour. Res.*, 43, W07447, doi:10.1029/2006WR005653.
- Weingartner, R., Aschwanden, H. (1992): Abflussregimes. *Hydrologischer Atlas der Schweiz*, Tafel 5.4, Bern.
- Widmann, M, Schär, Ch. (1997): A principal component and long-term trend analysis of daily precipitation in Switzerland. *Int. J. Climatol* 17:1333-1356.
- Zappa et al. (2003): Seasonal water balance of an alpine catchment as evaluated by different methods for spatially distributed snowmelt modelling. *Nordic Hydrology* 34(3):179-202.

# Mountain Vegetation under Environmental Change

Christian Körner

Institute of Botany, University of Basel, Switzerland

Global trends of climatic warming are more pronounced in mountains as evidenced for the Alps (Beniston 2005, Keller et al. 2005), but also holding for the Andes (Vuille et al. 2003) and equatorial Africa (Hemp 2005). At the same time, temperature is the major driver of the elevational stratification of life zones and the distributional ranges of plants and other species in mountains. Hence, warming should strongly affect mountain biota in general and life under marginal low temperature conditions in particular (Körner 2003).

As climatic warming progresses, extreme events are likely to become more frequent (Schär et al. 2004), several other important components of the atmosphere, particularly the ever rising concentration in CO<sub>2</sub>, but also atmospheric loading by soluble nitrogen compounds may affect mountain biota. On top of these abiotic drivers of life, mountain biota face significant changes through human landuse, globally. Effects range from abandonment of old cultural landscapes at high altitude to intensified and destructive over-utilization.

In this very brief account, I will summarize some of the evidence and trends for plant responses to these ongoing environmental changes. For more detailed information I refer to the literature cited below and Körner (2000, 2003).

## *Rising temperatures*

The effects of climatic warming in the recent past have left clear fingerprints on vegetation. Trees at the climatic treeline have never grown as fast as they do today. Radial stem diameter increments at the treeline are as high today as they were 100 years ago in the montane forest belt. In fact, the elevational differences in radial growth across the uppermost 300 m of elevation has nearly disappeared in recent years (Paulsen et al. 2000), underlining that trees are clearly relieved from thermal constraints, with no need for any other drivers (such as elevated CO<sub>2</sub> or nitrogen deposition) to explain the trends currently observed. There is compelling global

evidence the trees at their low temperature limit are not constrained by carbon, but by their ability to invest acquired photoassimilates into new tissue (Körner 2007).

The reason why trees reach their range limit at lower altitudes than shrubs, grasses and herbs has to do with their stature. Tall, aerodynamically open tree canopies are closely coupled to ambient air conditions, causing trees to track air temperature including the current trends of warming. In contrast, plants forming shrub, grassland and fellfield vegetation engineer their microclimate by small stature and compact growth forms (Körner 2007). For these plants climatic warming will become less effective and microhabitat mosaics will facilitate local re-arrangements rather than a general upslope migration (except for a few pioneer taxa).

There is evidence that some alpine/nival plant species respond by spreading upslope. The responses are much faster in ruderal plants such as rockfield pioneers (Grabherr and Pauli 1994) or snowbed vegetation (Bahn and Körner, 2003) and are slower in trees. When historical treeline data are compared with current data, one must carefully distinguish between infilling of open terrain due to landuse changes and true elevational advances of treeline. A recent assessment for the Alps revealed that 96% of the increase in tree cover in upper Swiss mountain forests is due to such infilling, and only 4% can be attributed to an upslope advance of the forest line (Gehrig-Fasel et al. 2007).

The question of whether the current upslope migration of some taxa is reflecting (1) a natural trend or (2) a response to anthropogenic warming is not easy to resolve, given that the reference observations from summit regions were made at the beginning of the 20<sup>th</sup> century's recovery from the impact of the little ice age. New data from decadal monitoring of nival vegetation suggests a direct influence of the most recent warming (Pauli et al. 2007). Unbiased effects of recent climatic warming may be more clearly seen in less marginal habitats. A very broad comparison of plant species inventories over large parts of France suggest a general upslope migration of taxa in the montane belt (Lenoir et al. 2008).



*Elevated CO<sub>2</sub>*

Whether atmospheric CO<sub>2</sub> enrichment is able to stimulate growth in high elevation plants is rather uncertain. From the evidence we have from in situ CO<sub>2</sub> enrichment in the Alps, neither late successional (Körner 1997) nor early successional alpine grassland and herb communities (E. Hiltbrunner et al. unpublished) take any advantage from higher CO<sub>2</sub> concentrations. The same was found for dwarfshrubs near the treeline (T. Zumbunn et al. unpublished data). For young treeline trees the evidence is split. While there was no response to 6 years of CO<sub>2</sub> enrichment in *Pinus uncinata*, the deciduous, more pioneer-like *Larix decidua* shows a stimulation of growth (Handa et al. 2006, Handa et al. 2005). Should this difference persist we may anticipate a re-arrangement of the treeline ecotone's species composition in the future.

*Nitrogen deposition*

In the long run, CO<sub>2</sub> enrichment can only stimulate plant growth to the extent that resources other than CO<sub>2</sub> permit. Hence, one could expect that plants receiving extra mineral nutrition could exert a growth response to CO<sub>2</sub>. However, for alpine grassland this has been disproven (Schäppi and Körner 1996). Even ample nutrient supply did not lead to a measurable growth stimulation in response to CO<sub>2</sub>, but nutrient addition alone (as NPK or N-only-fertilizer) caused biomass to double. Based on this and other still limited evidence (Fig. 1) it seems, the major changes in terms of growth in alpine biota will be introduced by climatic warming (and the associated changes in precipitation and snow pack) and nitrogen deposition, and not by CO<sub>2</sub> enrichment. Without exception, nitrogen addition does stimulate plant growth in cold environments including high alpine vegetation. Even very moderate rates of wet deposition (around 10 kg ha<sup>-1</sup> a<sup>-1</sup>) are likely to cause significant biomass responses (ongoing work by E. Hiltbrunner, Basel).

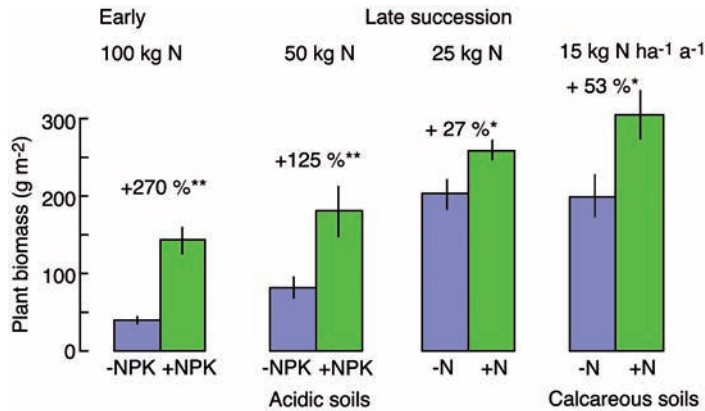

Fig. 1: Biomass responses to different rates of nutrient addition in alpine vegetation in the Alps (data from Schächli and Körner 1996, Heer and Körner 2002, E. Hiltbrunner, unpublished). Note that in some cases N was added in form of NPK-fertilizer and in other cases as  $\text{NH}_4^+$  and/or  $\text{NO}_3^-$ . From circumstantial evidence, P and K are unlikely to be effective. For comparison, lowland wet deposition of N in this region is in the order of 20-50  $\text{kg ha}^{-1} \text{a}^{-1}$ , whereas current rates in the central Swiss Alps at 2500 m have been found to be 5  $\text{kg ha}^{-1} \text{a}^{-1}$  (Hiltbrunner et al. 2005).

### Conclusions

Overall, none of the responses of biota seen so far suggest dramatic losses of species or habitats in the Alps, and responses lag substantially behind climatic trends, with species still nested in a thermal niche, commonly broader than the extent of predicted climatic warming. This does not preclude a narrowing of a species' range or expansion of species into new areas (Guisan et al. 1998, Guisan and Theurillat 2000, Randin et al. 2006), and for some already marginal habitats these changes are significant. A loss of species is still very unlikely for the Alps, given the enormous topographic diversity of mountain regions. Small scale mosaics of life conditions commonly permit short distance escapes from what might become a too warm or too dry microhabitat.

The public debate suffers from a confusion between the local or regional disappearance of a species and the extinction of a species from the planet, both often addressed by the same, thus misleading term 'extinction'. Quite often we are reported the 'extinction' of a species (from a certain area) that is otherwise still very abundant in other regions. Such alarmistic jargon does not serve the credibility of science and will exert negative feedback of public opinion in the long run as we had witnessed during the forest decline debate. I do not wish this to be understood as a neglect of the significance of ongoing changes in some biota, but suggest a more careful communication.

*References*

- Bahn M, Körner C (2005) Recent increase in summit flora caused by warming in the Alps. In: Nagy L, Grabherr G, Körner C, Thompson BDA (eds.), *Alpine biodiversity in Europe*. Berlin.
- Beniston M (2005) Mountain climates and climatic change: An overview of processes focusing on the European Alps. *Pure Appl Geophys* 162:1587-1606
- Gehrig-Fasel J, Guisan A, Zimmermann NE (2007) Tree line shifts in the Swiss Alps: Climate change or land abandonment? *J Veg Sci* 18:571-582
- Grabherr G, Pauli MGH (1994) Climate effects on mountain plants. *Nature* 369:448
- Guisan A, Theurillat JP, Kienast F (1998) Predicting the potential distribution of plant species in an Alpine environment. *J Veg Sci* 9:65-74
- Guisan A, Theurillat JP (2000) Assessing alpine plant vulnerability to climate change: a modeling perspective. *Integrated Assessment* 1:307-320
- Handa IT, Körner C, Hattenschwiler S (2006) Conifer stem growth at the altitudinal treeline in response to four years of CO<sub>2</sub> enrichment. *Glob Change Biol* 12:2417-2430
- Handa IT, Körner Ch, Hattenschwiler S (2005) A test of the tree-line carbon limitation hypothesis by in situ CO<sub>2</sub> enrichment and defoliation. *Ecology* 86:1288-1300
- Heer C, Körner Ch (2002) High elevation pioneer plants are sensitive to mineral nutrient addition. *Basic Appl Ecol* 3:39-47
- Hemp A (2005) Climate change-driven forest fires marginalize the impact of ice cap wasting on Kilimanjaro. *Glob Change Biol* 11:1013-1023
- Hiltbrunner E, Schwikowski M, Körner Ch (2005) Inorganic nitrogen storage in alpine snow pack in the Central Alps (Switzerland). *Atmos Environ* 39:2249-2259
- Keller F, Goyette S, Beniston M (2005) Sensitivity analysis of snow cover to climate change scenarios and their impact on plant habitats in alpine terrain. *Clim Change* 72:299-319
- Körner Ch (2000) The alpine life zone under global change. *Gayana Bot (Chile)* 57:1-17
- Körner Ch (2003) *Alpine plant life* (2nd ed.) Springer, Berlin
- Körner Ch, Diemer M, Schächli B, Niklaus P, Arnone J (1997) The responses of alpine grassland to four seasons of CO<sub>2</sub> enrichment: a synthesis. *Acta Oecologica* 18:165-175
- Körner Ch (2007) Climatic treelines, conventions, global patterns, causes. *Erdkunde* 61:316-324
- Lenoir J, Gégout JC, Marquet PA, de Ruffray P, and Brisse H (2008) A Significant Upward Shift in Plant Species Optimum Elevation During the 20<sup>th</sup> Century. *Science* 320:1768-1771
- Pauli H, Gottfried M, Reier K, Klettner C, Grabherr G (2007) Signals of range expansions and contractions of vascular plants in the high Alps: observations (1994-2004) at the GLORIA\*master site Schrankogel, Tyrol, Austria. *Glob Change Biol* 13:147-156
- Paulsen J, Weber UM, Körner Ch (2000) Tree growth near treeline: abrupt or gradual reduction with altitude? *Arctic Antarct Alp Res* 32:14-20
- Randin CF, Dirnbock T, Dullinger S, Zimmermann NE, Zappa M, Guisan A (2006) Are niche-based species distribution models transferable in space? *J Biogeogr* 33:1689-1703
- Schächli B, Körner Ch (1996) Growth responses of an alpine grassland to elevated CO<sub>2</sub>. *Oecologia* 105:43-52

## Global Change and Sustainable Development in Mountain Regions

- Schär C, Vidale PL, Luthi D, Frei C, Haberli C, Liniger MA, Appenzeller C (2004) The role of increasing temperature variability in European summer heatwaves. *Nature* 427:332-336
- Schäppi B, Körner Ch (1996) Growth responses of an alpine grassland to elevated CO<sub>2</sub>. *Oecologia* 105:43-52
- Vuille M, Bradley RS, Werner M, Keimig F (2003) 20<sup>th</sup> century climate change in the tropical Andes: observations and model results. *Climatic Change* 59:75-99

# Is there a Future for Mountain Forestry?

Dieter Stöhr

Tyrolean Forest Service, Innsbruck, Austria

Tyrol has a powerful timber industry, processing at least 3 million m<sup>3</sup> of timber every year. The share of trees derived from tyrolean forests is relatively small (30%), while the majority of timber processed in Tyrol is grown in Bavaria and other neighbouring countries, where harvesting is done fully mechanized and at low production costs. Forestry on steep mountain slopes has become an exception in Europe and has an uncertain future.

In addition to economic uncertainty, ecological risks for forests are also rising. Climate change may affect trees and forests of the Alps in diverse ways. Trees may either suffer from heatwaves and drought or increase in growth even on forest sites that are close to each other. Effects on the treeline are uncertain as well. Expanding forests in the timberline ecotone are attributed to landuse changes rather than to climate change.

## **Alpine forests are managed since centuries**

Timber and fuelwood were the key resources for the mining and refining of salt in Tyrol. Timber and fuelwood were floated along the river Inn from St. Moritz (CH) to Hall. According to Palme (1975) the total timber consumption of a single mine amounted to more than 100.000 m<sup>3</sup> in the 16<sup>th</sup> century. Even today, the Engadin-valley in Switzerland still shows the scars of deforestation and its consequences in an alpine landscape. Tyrolean forest history is a story of overusage and resource depletion. We have learned from the past that sustainable forestry is essential for the alps.

## *Current state of forests*

### **Forest area**

Since the middle of the 20<sup>th</sup> century, forests in the Alps have been expanding (Russ, 2004; Strobel et al., 1999), as a consequence of land use and maybe also due to climate change. In Tyrol, the forest area has been expanding at an annual rate of 800 ha since 1960, resulting in an 5% increase of forest area in Tyrol during this period.

The main reasons for this development are:

- as steep meadows and pastures were abandoned, trees have invaded agricultural land through natural regeneration,
- high elevation afforestations were implemented in some regions to protect settlements from avalanches, land slide or floods.

The expansion rate of forests might further increase in the future, if climatic effects stimulate an accelerated upward movement of the tree line.

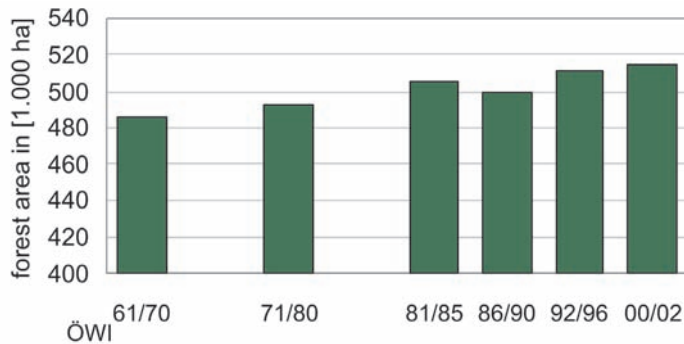

Fig. 1: Development of forest area in Tyrol (data from Austrian forest inventories, ÖWI)

### Growing stock

In most regions of the Alps, forests have closed in the last decades. Cautious timber removals, well below the annual increment, have led to high growing stock levels. Other reasons for this development are the decreasing intensity of cattle and sheep grazing inside forests and the disappearance of other forms of agricultural use in forests, such as litter racking and tree pollarding (Haas, 2002, Stuber and Burgi, 2001), resulting in better conditions for tree regeneration .

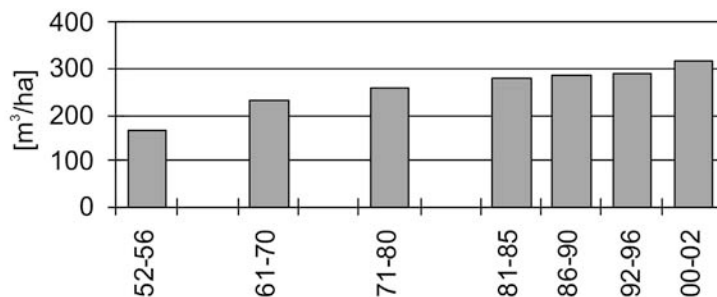

Fig. 2: Development of growing stock in Tyrolean forests (data from Austrian forest inventories)

### Forest health and vitality

Forest health and vitality indicators have not developed in the same direction as forest growth indicators, especially in protective forests (characterized by a dominance of older trees). Crown conditions are still a cause of concern as the amount of trees with satisfactory crown condition is still decreasing (Amt der Tiroler Landesregierung, 2006).

Mass propagations of bark beetles are another threat for alpine forests that have become more important in the last decade, even though the incidence of windthrow and snow break, which trigger outbreaks of bark beetles, did not show a clear trend during this period (Krehan and Steyrer, 2007). The increasing frequency of massive bark beetles outbreaks might be influenced by climate change and eutrophication of forest ecosystems by atmospheric deposition.

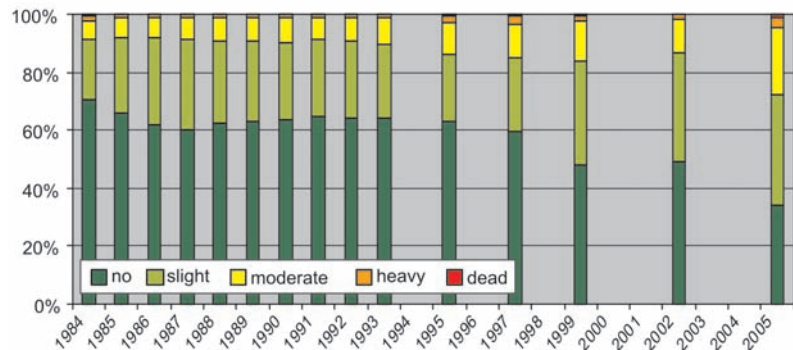

Fig. 3: Crown condition in protective forests in Tyrol (Amt der Tiroler Landesregierung, 2006)

### Growth rates increase whereas crown conditions decline

This directly opposite trends between growth rates and crown condition seem to be inconsistent and hard to explain. The following comparison may be helpful: Forests might respond similarly to people with an imbalanced diet, increasing in weight but loosing overall fitness at the same time.

### Scientific questions to be answered:

- How do we identify sites affected by:
  - eutrophication
  - climate change
  - massive pest outbreaks
- What are possible measures to limit the effects of eutrophication and climate change on these sensitive sites

### *Productive functions*

Alpine forests were often over-exploited in the past, but after World War II the general conditions changed. Reduction of agro-forestry, eutrophication with nitrogen by atmospheric deposition and climate change have led to increasing increments in most of the alpine forests. In most areas of the Alps, fellings were reduced due to the decreased timber prices, growing production costs and rigorous forest laws.

In Tyrol the situation is considerably different: Forest owners, advised by the Tyrolean Forest Service, have conducted fellings at an „all time high“ rate in recent years. One of the primary objectives for this enhancement of harvest activities in Tyrolen forests is to rejuvenate the old stands in protective forests to sustain their protective function in the future.

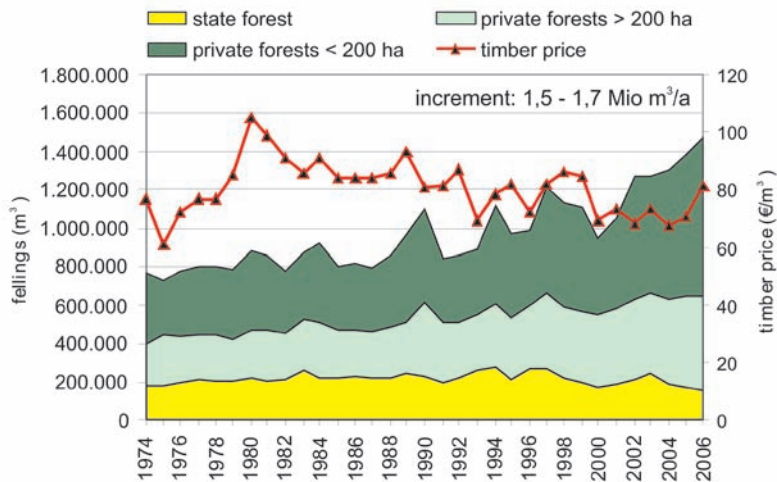

*Fig. 4: Timber and fuelwood production in Tyrolean forests (Amt der Tiroler Landesregierung, 2006)*

### **Forestry on steep slopes is expensive**

In Tyrol only 10% of timber harvest is done fully mechanized, while 90% of all the trees are still cut with manually operated chainsaws. To sustain forestry in mountain forest, the Tyrolean Forest Service provides a package of subsidies to encourage forest owners to manage their forests. Ninety percent of all the government aid is invested in measures to improve the stability and rejuvenate protective forests.

### **Efficient forestry is restricted by small plots**

In many areas of the Alps, forests are owned by a multitude of landowners. In Tyrol alone 30.000 forest owners own a total forest area of 510.000 ha. In addition, more



than 20.000 beneficial owners have specific rights to obtain fuel wood and timber and to graze cattle in the forests. As a consequence, most timber harvests need to be harmonized between neighbours. Our local foresters in the communities try to convince land owners to coordinate their timber harvest, to share the costs and bring an appropriate assortment of timber to the market.

A first attempt to manage timber logistics from forest to the sawmill efficiently, is a GIS – system providing the timber industry with all the information about the planned timber harvests within the current season.

### **Timber industry plays an important role in the economy of the Alps**

In Austria wood products are exported, representing 8,5 billion € in annual revenues. So the timber industry plays a key role in the economy of some regions in the Alps. However, some of the risks, as mentioned above, jeopardize the timber supply.

### **Scientific questions to be answered:**

- How to manage forests with a multitude of land owners, most of them without any experience in forestry?
- How can forests on steep slopes, affected by avalanches, erosion and rockfall be managed efficiently?
- How to enhance productivity without adverse effects on other functions (biodiversity, erosion,...)
- How to maintain sustainable forestry with landowners living far away from the forest and with no experience in forestry?

### *Protective functions*

In Tyrol, only 12% of the land area is suitable for permanent settlements. The rest is too steep, endangered by natural disasters, or located at too high an altitude. So the protective functions of our forests play an important role to the safety of our settlements. Figure 5 shows the hazard zone map of the village of Neustift. The map illustrates the shortage of areas where the risk of natural disasters is low. In areas surrounded by red lines, buildings may be destroyed by torrents or avalanches; the yellow lines indicate areas where buildings may be damaged by these hazards.

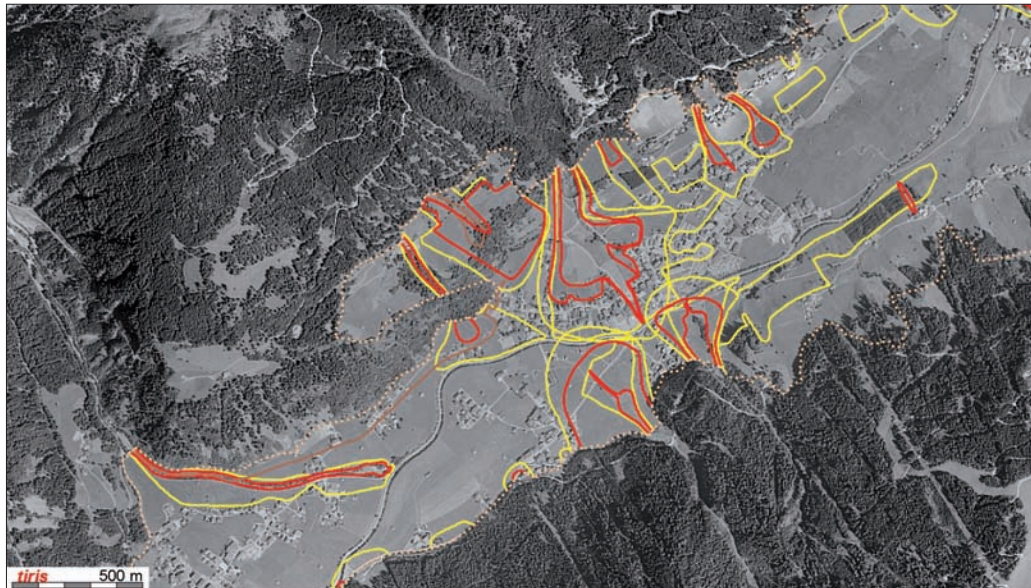

*Fig. 5: Hazard zone map (Amt der Tiroler Landesregierung, tiris)*

### **Is forestry needed to preserve a forests protective functions?**

There is no single general answer to this question. Due to specific site conditions, forest community composition and historic forest management, every stand bears a specific risk. The so-called “Stockwald” in St. Jakob i. Defereggental is an example of



*Fig. 6: Stockwald, St. Jakob i. Defereggental (Amt der Tiroler Landesregierung)*

how things might go wrong when forest management is absent for several decades in a steep mountain forest. Some characteristic features of the “Stockwald” are:

- protective forest by decree
- no fellings since 1850
- forest dominated by a single tree species (spruce)
- unfavourable height/diameter relationship

In 1977 Mayer and Pitterle (1988) stated that uniform stands dominating the whole Stockwald, bear a high risk of windthrow. This forecast proved to be surprisingly accurate, as most of the stands mapped as unstable, collapsed within 30 years, leaving behind an area of 20 ha without mature trees. Massive snowpack-stabilizing structures which also protect the village from rockfall had to be established on the site.

**Scientific questions to be answered:**

- Are there new opportunities, linked with climate change, to prevent natural disasters
- How can forests on steep slopes, affected by avalanches, erosion and rockfall be managed efficiently?
  - reliable techniques of pest control
  - are there sites, which do not need be managed?
- Which tree species will cope best with the future climate?
- How to establish forests now, in anticipation of future climatic conditions that might be quite different?
- How to reintroduce tree species that are vulnerable to deer browsing?

*Biodiversity*

Biodiversity may not be a priority goal for local foresters, but the way forests are managed has strong implications for biodiversity.

**Scientific questions to be answered:**

- Does increasing growing stocks, dense forests and eutrophication lead to decreasing biodiversity?
- How does damage by wildlife affect biodiversity in the long run?

### *Recreation and forestry*

Forests are also an important „sport facility“ for tourists and locals in many areas of the Alps. This development produces conflicts with the traditional land users such as forest owners, hunters and farmers. To find consensus between different groups of land users, the Tyrolean Forest Service has developed some nice examples for cooperation between tourism, land owners and other user groups:

- The Tyrolean mountainbike model: opening more than 5.000 km of forest roads for cycling and transferring fees from tourism to landowners (all the routes are accessible via the internet).
- The ski mountaineering project in cooperation with the Austrian Alpine Club: establishing small pastures in certain forests to reopen common ski routes which have become impassable by expanding forests.
- Various projects where landowners receive rent from tourism for allocating their land for recreational activities like climbing, paragliding, canyoning and others.

#### **Scientific questions to be answered:**

- What are the effects of recreational activities on wildlife and deer damage?
- How can forestry and tourism coexist or benefit from each other?

### *Literature:*

Amt der Tiroler Landesregierung (2006): Tiroler Waldbericht 2006

Haas J.N. (2002) 6000 Years of tree pollarding and leaf-hay foddering of livestock in the alpine area. Centralblatt f.d.ges. Forstwesen, 119., Heft ¾, S 231-240.

Krehan, H.; Steyrer, G., (2007): Borkenkäfer 2006: Situation und Monitoring. Forstschutz Aktuell Nr. 39

Mayer H., A. Pitterle (1988): Osttiroler Gebirgswaldbau. Österr. Agrarverlag, Wien

Palme R. (1975): Die Anfänge der Holzschaffung für die Saline und das Bergwerk Hall in Tirol. Centralblatt f.d. gesamte Forstwesen, 92, 3.

Russ W. (2004): Mehr Wald ein positiver Trend? BFW Praxisinformation 3/04

Strobel, T.; Keller, M.; Paschedag, I.; Schnellbacher, H.J. (1999): Waldfläche und Waldeigentümer. 39-52. In: Schweizerisches Landesforstinventar, Ergebnisse der Zweitaufnahme 1993-1995 eds: Peter Brassel, Urs-Beat Brändli

Stuber M., M. Bürgi (2001): Agrarische Nutzungen in der Schweiz 1800-1950. Waldweide, Waldheu, Nadel- und Laubfutter. Schweiz.Z.Forstwes. 152, 12: 490-508

# Mountain Tourism in a Climate of Change

Philippe Bourdeau

Institute of Alpine Geography (University of Grenoble), UMR Territoires-PACTE

The uncertainty and the crisis in European mountain tourism are both caused by climate and geo-cultural change. This is why, for many observers, the kind of tourism established during the second half of the 20<sup>th</sup> century appears to be a « worn-out » model, and should be reorganised thoroughly. This will involve drastic adaptation measures. Such new watching grids will be required to understand and monitor the way out of « all ski », « all snow » and even «all tourism». The tourism research agenda and the networking project of the International Scientific Committee on Alpine Research (ISCAR) is an operational contribution to start this process.

## *Mountain tourism under stress*

In spite of optimistic forecasts about global tourism industry from the World Travel Organization, and a wider offer than ever (sports, heritage, wellness), mountain tourism is experiencing uncertainty, stress and crisis. In this context, climate change both is an indicator for structural contradictions and weaknesses of alpine tourism, and a “booster” for cultural, geographic and economic revolution in the tourism industry. But climate is far from being the only factor in mountain tourism, it is also challenged by major changes such as market « maturity », loss of shares in the tourist market in the Alpine countries throughout Europe, competition from other tourist destinations, the growing economic and territorial divide between large and small resorts, new recreational practices, the ageing of the tourist population, demands for environmental quality, the changed notion of resort, the social issue of seasonal work, the need for huge new investments against the background of a reduction of public funding, and risk management. For many observers the tourist system based on winter sports becoming popular in the second half of the 20<sup>th</sup> century, is now considered a “worn-out” model and will need to undergo major reorganisation requiring drastic adaptation measures.

1. *Change in alpine tourism: paying more attention to geo-cultural rising forces*

If one reads skiing and snowboarding magazines regularly, one will not be surprised by the omnipresence of icons and slogans containing a great number of promises about powdery snow and exciting experiences. But, digging deeper, one discovers that there is a growing geo-cultural fragmentation between the pictures of urban surf culture (e.g., *wall-ride*, omnipresent references to buildings and industrial structures: concrete, tarmac, trucks, quads, helicopters) and the pictures of travel and exotic « spots » (e.g., Kashmir, Kamchatka, British Columbia, Australia). On the other hand, with the exception of a few advertising spaces devoted to them, the winter sport resorts seem to have a very low profile in the media landscape. This decline in visibility becomes evident by the prominence given to equipment brand names in resort advertisement, and in the use of high level “riders” as promoters of these brands. Increasingly, this can be seen in hybrid sport-festival events which have taken root in urban areas, such as “*Air & style*” in Munich which brings together snowboard, motocross and music; on one and the same stage, or the “*Imperium & Technine Harbour Rail Jam*” organised in the port of Antwerp. Therefore, climate is not the only variable of mutation in the world of winter sports, a change in the mythology of tourism is ongoing, infusing new ways of using space and practising snow sports not only in the resorts, but also in between and outside them. The numerous raids, camps, walking and cycling tours which ostensibly triumph over the static world of the resorts are further evidence of this trend.

The idea of the resort as a unity of place, time and action, based on the functional triptych « accommodation - ski-lift - slopes », can thus be circumvented or deviated by a new interpretation of the mountain playground. One example is the striking contrast that can be observed by the expansion and interconnection of large ski areas, and the micro-scale of space in which the new sports are practised by young snow surfers. The module of a *snowpark*, but also increasingly a *mundane slope*, an “improved” bump, a rock, a tree trunk, a snow-covered flight of steps or the door of a building, become possible means for an expression focused on movements and shared emotions. Creating a “tailor-made” activity space, fashioning it and putting it together with simple tools (e.g., hands, spades, snowboards) become an integral part of these new activities, while the need for ski lifts turns out to be of secondary importance. These selective or alternative games with standardised resources provided by the resorts, favouring proximity, simplicity, openings and deviations – and quite happily adapt to a lack of snow – also corresponding to the

desire of many visitors to get off the slopes and explore new types of playgrounds - on skis, snowshoes or on foot.

This geo-cultural change of everything illustrates the important role of counter-cultures in tourism, and their ability to bring new uses and new experiences to the mountain. It also shows a shift from an initial technical and sports image (modern) to a play image (post-modern) and even an eco-image (transmodern). Finally, it indicates the establishment of novel and symbolic links between town and mountain, between “Here” and “Elsewhere”, and between common places and famous places. This is why skiing in a snow-dome, climbing on a resin wall, “trekking” in a rural area, or “nordic walking” in town are becoming more common. Such a rise of mixed and hybrid phenomena – transition and cross-overs, multi-identities – can be seen as “betweenness”, “a place or a time where differences and borders are redefining themselves” (Sibony, 1991).

In this context, recreational practices close to home are being reintroduced. This is illustrated by numerous local and regional communication campaigns where slogans like “*No need to go far to feel good*” (Rhône-Alpes Regional Tourism Committee, 2005) or “*Madagascar? No, the Jura!*” (The Departmental Committee of Jura Tourism 2008) are becoming common. In the same way, in the “*Explore Unusual Worlds*” campaign (Swiss Federal Railways, CFF, 2008), pictures of the Alps are mixed with those of astronauts, Loch Ness or King Kong in New York. This crossing of the traditional divide between everyday vs uncommon space, time and activities constitutes a growing hybridization between the sedentary vs mobility; work vs leisure; residential, productive and recreational functions; close-to-home tourism vs tourism involving a stay away from home; visitors vs those who are visited. This movement also corresponds to multiple reinterpretation of close-to-home space and time which transform their triviality and lead to a (re)discovery of a multitude of experiences. Symbolic of this approach is, for example, the three-week hike “*Here becomes Elsewhere*” organised in 2002 in the urban area of Grenoble by a group of artists and described in a book entitled “*The Scenery was Exceptional*” (Ici-même, 2004). The event was conceived as an new exploration of the uses of urban space: camping in public spaces, accommodation with a family, ”performances” and get-togethers at markets, collecting and broadcasting sounds and images. Here we are getting close to an “experimental” tourism, served by an unbridled, playful creativity (Anthony et al., 2005).

## 2. The need for new watching grids

### 2.1. From « Mountain » to « mountains »

As mountain tourism is getting more and more diversified, a growing separation of sub-cultures (“tourists”, “mountaineers”, “performers”, “adventurers”) becomes evident, corresponding to different ways of partaking in outdoor recreation and giving sense to mountain nature. It is linked with a symmetrical separation of sub-playgrounds (“indoor”, “aroundoor”, “outdoor”, “wildoor”<sup>1</sup>) defined by distinct ways of managing equipment, amenities and security (Augustin et al., 2008). A shift from “mountain” to “mountains” is then to be considered in both functional and symbolic terms.

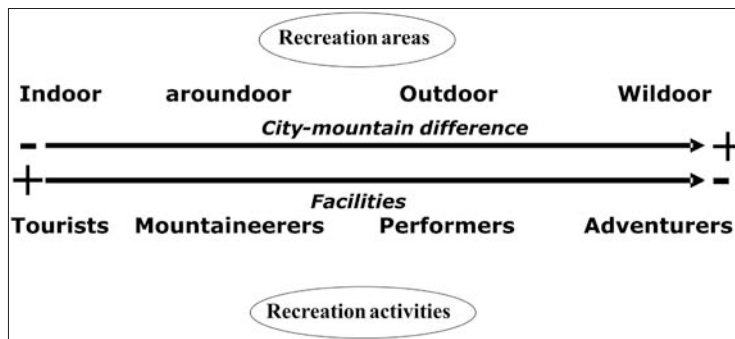

Fig. 1: The shift from “Mountain” to “mountains”: a geo-cultural gradient (J. Corneloup & Ph. Bourdeau)

### 2.2. From tourism to post-tourism

While towns are rejoicing once more and are becoming exotic thanks to urban ecology (for example : Paris-Plage), tourist sites and practices seem, on the contrary, to be stricken by a sort of end of tourism utopia and uchronia facing population crisis (ageing population), climate crisis (greenhouse effect), energy crisis («the end of oil»), economic crisis (precariousness), identity crisis (alarming otherness, guilt feelings), sanitary crisis (pandemics) and security crisis (attacks at tourist destinations) (Bourdeau et Al., 2006). While becoming crucial to the economy, the culture and lifestyles of « developed » societies, tourism seems thus to dissolve and to shy away increasingly like an autonomous practice and object, as several authors point out or suggest (Urry, 2002; Viard, 2006).

Of course, such mutations can be interpreted in terms of a tourism crisis, and show that they are leading to the development of tourism of crisis, particularly

<sup>1</sup> “Wildoor” is a neologism (contraction of wilderness + outdoor) meaning a very low level of equipment and management of a nature area in the context of European mountains, e.g. quite different from wilderness areas in America, Asia or Australia.



based on a relocalization of the relationship between Here and Elsewhere. It is even more interesting to analyse them in terms of post-tourism. Post-tourism provides an account of a change of status of tourist practices and destinations in the context of globalisation and post-modernity: amenity migration (Perlik, 2006) and new residential practices (Viard, 2006), a calling into question of the tourist utopia and uchronia, a search for continuity between holiday practices (recreational, social, cultural and spatial) and everyday practices (Urry, 2002), the turn of ordinary places into tourist destinations, experimental tourism and neo-situationism, new relationships between town and mountain in the context of metropolisation. This widened sense of post-tourism therefore refers to a work outside the framework of tourist thinking, structuring and practices because of the global evolution of society and the sectorial evolution of recreational areas. It will be necessary to renew the social sciences « tool box » by mobilizing new notions and references: the transition from staying there to living there (Lazzarotti, 2001, Stock, 2004 et 2006), from tourist-mode economy to presence-mode economy (Davézies, 2008), from tourist to « recrerésident » (Lajarge, 2006).

### 2.3. From a space-time order to another

The first half of the 20<sup>th</sup> century witnessed a space-time revolution in the tourist sector: the sea became the dominant summer destination while mountains established themselves as the most popular winter destination; that is to say, a complete reversal of geographical and seasonal polarity in regard to the initial situation in the 18<sup>th</sup> and 19<sup>th</sup> centuries took place. This overturning of habits which is linked to geo-cultural factors in particular (increase in heliotropism, evolution of our relationship with our body, development of skiing, mass recreation ...) has of course created great demands for adaptation capacity of tourist operators

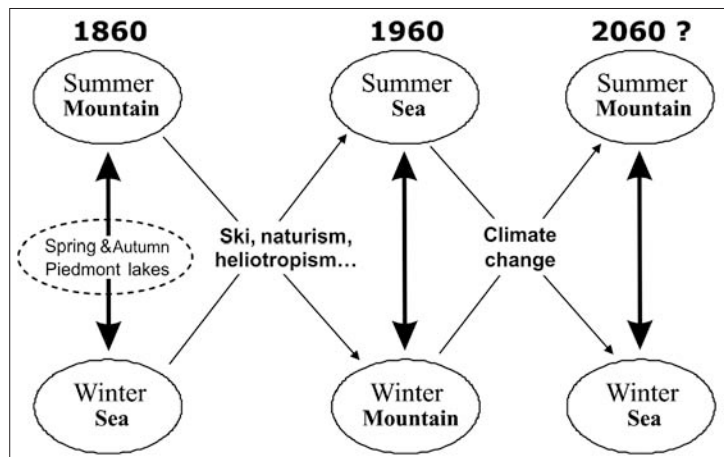

Fig. 2: Towards a New Seasonal Turnaround of Tourism Polarities? (Ph. Bourdeau)

and destinations. While it is at the origin of contemporary tourism, it is obvious that this geo-seasonal balance cannot be considered as an immutable fact. Moreover, close observers are not mistaken in suggesting that the current climate change, acting as a catalyst in the structural mutations of tourism, (Elsasser & Messerli, 2001), could eventually lead to a new space-time repolarisation. We would therefore witness a sort of « back to square one » of tourism with summer flow turned towards the mountains as a natural « air-conditioned zone », and winter flow drained by the seaside offering a large selection of various swimming, sailing and wellness activities without the drawbacks of heat wave and the danger of sunburn.

### **2.4. Mountain to the fourth: four seasons, four spaces, four activities, four economies**

Being a vector of an economy of substitution towards agriculture and mountain industry, the tourist sector finds itself facing the limits of its own stability, indeed of its durability. Without losing sight of the diversity of regional tourist topologies and destinations, the multiplicity of variables which influence the future of this sector, there seems to be an urgent need to advance beyond a number of certitudes. This « step to the side » cannot be satisfied with a simple tactical *aggiornamento*, in terms of marketing and communication, for instance, but it must constitute an authentic turnaround in strategy. The preoccupation with diversification linked to the attenuation of the effects of climate change is therefore not only based upon an offer of a variety of new recreational activities, but also upon the interest in new spaces, new publics, new times, new meanings. This is due to the assertion of the legitimacy of a multiplicity of protagonists and operators, of working methods, of choices of professional life, of everyday life and recreational models. And at the same time, intensifying respect for the environment. On that condition, the way out of « *all ski* » can be serenely contemplated as a way out of « *all snow* » and even of « *all tourism* ». In the future, the living mountains can hope to assert themselves as mountains of the « four seasons » (winter, spring, summer, autumn), of the « four spaces » (resorts, villages, protected areas, market town centres<sup>2</sup>), of the « four activities » (agriculture, crafts-services, recreation, information and communication technologies) and of the « four economies » (production, public, residential, social).

---

<sup>2</sup> Or “indoor”/“aroundoor”/“outdoor”/“wildoor” (see above paragraph 2.1).

### *3. Towards a mountain tourism research agenda: the propositions of ISCAR*

#### **3.1. Overall needs, goals and actions**

As mountain tourism is at a “crossroad” regarding to the growing complexity and uncertainties of climate change and the international tourist market, the programming, coordination and animation of research on this topic must:

- follow a multi-field approach crossing natural and social sciences: history, economy, geography, ecology, sociology, ethnology, law sciences;
- provide case studies in different countries allowing first to make comparisons which are currently lacking, and then to identify innovative practises;
- take into account the diversity of the forms and models of tourism development , from its more “industrial” forms (winter sports resorts, leisure centres) to its more “spontaneous” forms;
- take into account the weight of history, heritage and culture of tourism and tourist places as regards the importance of these variables in the capacity of sustainable innovation;
- recognise the need for replacing tourism in the context of the evolution of mountain areas at a European scale: transport infrastructures and their environmental impact; new residential strategies and request for services; phenomena of metropolisation; relations between urban and natural areas;
- recognise the need for crossing local and global approaches of crucial questions like the impact of the climate change, sustainable mobility, new information technologies.

According to such context and goals, 7 research topics are suggested by ISCAR, referring to the topics emphasized by the “Tourism, leisure, sports” chapter of the 2005-2010 MAP of the Alpine Conference:

1. Evaluation of competitiveness of existing and new tourist models in the context of globalization;
2. Relationships between culture and tourism in tourist areas;
3. Interactions between urbanisation and alpine tourism;
4. Sustainable management of winter stations;
5. Governance and co-operation in alpine tourism: developing policy-based and agent-based approaches: How to organize tourism within and among tourist areas?
6. Potentials and strategies of sustainable nature-based tourism and sports in the Alps;
7. Tourist transport infrastructures in mountain areas.

*Conclusion. Networking as a first step (ISCAR mountain tourism project)*

Taking into account the fact that scientific exchanges and cooperations at the European level. are very poor in the field of mountain tourism. One must improve this cooperation and stimulate interdisciplinary and intercultural approaches, in connection with political, economical, social demand and related to other research fields (climate, demographic, economic, social and cultural change in mountain areas).

Two approaches could be to improve the regarding the research agenda of the Alpine Convention:

- identify research needs in mountain and alpine areas more precisely ( at European Union level following an interdisciplinary approach), and
- provide information to the bodies of the European Union and of the Alpine Convention, in collaboration with SOIA.

To reach these approaches, the following actions will be needed:

- First, set up a network of research centres and researchers. It should be based upon the existing networks, if possible, and include basic – though still lacking– actions like the creation of an address book and a thematic bibliography, the identification of available databases and surveys, the gathering of information about disciplines, research topics and areas, local and international partnerships. This will allow the production of cartographic compilations of existing –or lacking– alpine tourism research.
- Secondly, develop shared expertise to enable the launching of transalpine case studies allowing to make currently lacking comparisons, to stimulate relationships with public and private stakeholders (according to social relevance of topics), and foster enhanced research cooperation through meetings, publishing, and communication activities.

*Bibliography*

- Augustin J.-P., Bourdeau Ph., Ravenel L. (2008). Géographie des sports en France. Vuibert, Paris.
- Anthony R., Henry J., Nystrom A.-D. (2005) Lonely Planet Guide to Experimental Travel. Lonely Planet Publications, London.
- Bourdeau Ph. (Ed.), (2006). La montagne, terrain de jeu et d'enjeu. Ed. du Fournel, L'Argentière-la-Bessée.
- Bourdeau Ph. (Ed.) (2007). Les sports d'hiver en mutation. Crise ou révolution géoculturelle ? Lavoisier, Paris.
- Davézies L. (2008). La République et ses territoires. La circulation invisible des richesses. Le Seuil, Paris.
- Debarbieux B. (2005), Le tsunami de l'Océan indien : la première catastrophe naturelle mondialisée, Le temps, Genève, 5 janvier 2005, p. 11.
- Elsasser H., Messerli P. (2001). The Vulnerability of the Snow Industry in the Swiss Alps, Mountain Research and Development, Vol. 21.4, 335-339.
- Lajarge R. (2006), Des parcs sans jardin et des récréatifs sans touristes ? In Tourisme en campagne : scénarios pour le futur, POUR n°191, Paris, pp.42-46.
- Ici-même (2004), Les paysages étaient extraordinaires. Ed. Tous travaux d'art, Grenoble.
- Lazzarotti (2001), Les raisons de l'habiter, Habilitation à diriger les recherches, Université de Paris 7-Denis Diderot.
- Perlik M. (2006), The Specifics of Amenity Migration in the European Alps, in Moss L.A.G. (ed.), The Amenity Migrants: Seeking and Sustaining Mountains and their Cultures, CAB International, pp. 215-231.
- Sibony D. (1991). Entre-deux. L'origine en partage, Seuil, Paris.
- Stock M. (2004), L'habiter comme pratique des lieux géographiques, EspacesTemps.net, Textuel, 18.12.2004 <http://espacestemps.net/document1138.html>
- Stock M. (2006), L'hypothèse de l'habiter poly-topique : pratiquer les lieux géographiques dans les sociétés à individus mobiles, EspacesTemps.net, Textuel, 26.02.2006 <http://espacestemps.net/document1853.html>
- Urry J. (2002), The Tourist Gaze, Sage publications, London.
- Viard J. (2006), Eloge de la mobilité, l'Aube, La Tour d'Aigues.

**Annex. ISCAR (*International Scientific Committee on Alpine Research*) mountain tourism research agenda**

**1. Evaluation of competitiveness of tourist models in the context of globalisation**

**Rationale:** the evaluation of competitiveness has to be analysed regarding the future of tourism in the mountains. The main challenge is to link models of tourist development, as the life cycle model, with other models, like climate models, demographic models, trend in globalisation. This topic is not really present in scientific research, and no current research programmes have been identified so far.

**Research goals:**

- Develop a transalpine research programme to the proposed topic
- Competition and complementarity between “corporate and industrial” tourist model and “community and cultural” model
- Importance (international/big) sport events are for competitiveness

**Actions:**

- Programmatic (policies, programmes, EU, INTERREG, etc): please specify which policies, programmes; see also below: research institutions
- Cooperation, networking, meetings (dissemination, stakeholders)

**Research projects:** effects of climate change on summer and winter tourism in the mountains, will seniors tourism be a chance for the mountains? ; environmental and economic evaluation of sport events ; evaluation of sports events as regards ecological compatibility and improvement of environmental performance evaluation; evaluation of sports events as regards local/regional economic value creation as well as developing models to optimise local/regional values.

**Social relevance:** tourism is one of the most important economic sectors worldwide and is still growing. For many alpine regions, tourism is considered as the only sector with economic perspectives, notably to generate employment in alpine areas. But this strength is also a weakness as regards the increasing competition between tourist places on a worldwide scale, and regarding the loss of tourists noticed the Alps in the last 15 years.

**Addressed Stakeholders:** public and private tourist authorities (companies?) and organizations

**2. Relationships between culture and tourism** (including interactions between traditional and tourist cultures)

**Rationale:** includes both, traditional cultures (conservation, PR) and “tourist” cultures (promotion, innovation). Cultures have been studied in detail (more the traditional ones), but interactions are hardly known.

**Research goals:** better understanding of the interactions between traditional (domestic) and “tourist” (urban) cultures. Better understanding of cultural transformation in tourist resorts, compared to rural settlement. Better understanding of the role of tourism for the survival of local cultures (by keeping the local population on place). Historical comparison with former anthropological (case) studies.

**Actions:**

- Transalpine Research Programme on “interactions between traditional and ‘tourist’ cultures”.
- Case studies in different types of tourist/non-tourist areas
- Transalpine Research Programme: Role of culture (landscape, history, heritage, professional and local relationships, etc.) in tourist places identity and competitiveness

**Research projects:**

- Leading role of counter-cultures in the tourist innovation
- Culture as a major resource of the sustainable development of tourist sites and places in the Alps (relationships, information and knowledge, shared identity, heritage and territorial anchoring)

**Social Relevance:** Culture (in a broad sense) is a major variable of sense, development and competitiveness for tourism. Alpine tourism can rely here on a strong heritage (from landscape and traditional architecture to alpine clubs history, place identity, etc.) which is often neglected by political and economical stakeholders. It is therefore essential to point out this input.

**Addressed Stakeholders:** Tourist resorts, tourist engineering boards and departments (public and private)

**3. Interactions between urbanisation processes and alpine tourism, leisure and residence**

**Rationale:** more and more people are living and will live in urban areas, inside and outside the Alps. The urban, economic and demographic tendencies point out an emerging “post-tourism” process linked with retirement migrations, metropolisation, increase of neighbourhood tourism, social request for living all year round in holiday places. What will be the effects of this trend on alpine tourism: Will population concentrate on alpine towns (Innsbruck, Grenoble) and tourist centres (Chamonix, Davos)? What will be on the other hand the development in rural areas: will tourism decrease, or even increase, as a counterpart to urban tourism? International comparisons between case studies in different alpine areas seem to be an essential condition to understand the coming future of alpine status in Europe, not only as a “playground” but also as a place to live and play in a respected nature.

**Research goals:**

- analyse the transformation of economic structure, socio-cultural practices and land use changes in mountain areas in the frame of alpine-wide urbanisation processes and changes in tourism. This means especially the development of new forms of services in the mountains under the conditions of different demands in tourism (e.g. residences instead of classical tourism), new forms of habitats and settlement structures (e.g. stronger regional cooperation, densified settlement structures) and coping decline as “brain drain” and losing significance (e.g. by developing urban heterogeneity).
- analyse the effects of changing alpine-specific regional production systems
- analyse the effects of growing metropolitan areas (metropolisation) on adjacent regions
- Documentation of changes, evaluation of the results, interpretation of the consequences under the perspective of the goals of sustainable spatial and economic development, socio-cultural regional cohesion, bio-physical diversity and energy saving.

- give advice for spatial policies and governance rules of best practices for the applied research.
- enhance scientific progress for researchers in regional and social sciences such as spatial planning, urbanism, sociology, regional and economic geography

**Addressed stakeholders:**

- National and regional planning institutions according to their goals of sustainable spatial development
- Regional actors in tourism, government/administration, NGOs and also in other economic branches according to their goals of planning security and the capability for innovation.
- Transdisciplinary knowledge transfer to scientist in natural sciences as natural hazard research, climatology and hydrology and to researchers in the field of traffic/communications.

**4. Sustainable management of winter stations**

**Rationale:** the tendency to the reduction in the social request for winter sports in the Alps combined with the upcoming climatic change impose an effort of adaptation, economic and tourist diversification (winter-summer, sport-cultural heritage, etc.) on most of the tourist sites as well as an effort of quality (reception, landscape, architecture, respect of nature, etc.) facing to competition of other tourist places in Europe and in the world. Very often also a work of partial or even total restructuring and redeployment is imposed, for instance from tourism to residential and services functions.

**Research goals:** to identify and evaluate classic or innovative ways, methods and governance answers of restoration and restructuring of winter stations in different kinds of alpine context, to help to prevent crisis and to facilitate sustainable development. Furthermore, analyses of the property market in tourist resorts (not merely winter tourism) are required: How does this market work? Which are the goals of the different actors?

**Actions:**

- International comparisons between case studies in different alpine areas and different kind of winter sports stations
- Writing of a guide of innovative and exemplary answers in winter stations restoration
- What is happening with constructions built in the 1960ies: Slums, demolition, restoration, new/rebuilding?
- How can a destination for winter tourism develop to an all-year touristic destination?
- Developing models for a better balance between winter and summer/autumn seasons (economic, infrastructure, human resources aspects).

**Addressed stakeholders:** Public authorities, winter station managers, NGOs

**5. Governance and co-operation in alpine tourism**

**Rationale:** to analyse the decision and co-operation processes in the mountain resorts. Co-operation and “good” governance are widely recognized as key factors for the successful development of tourist destinations. But in general we know relatively little about the policy and decision-making processes and the public-private partnership in alpine destinations. If there is a lot of literature regarding “urban governance” in Europe, there is almost nothing regarding “tourist governance”.



**Research goals:** to carry out a certain number of case studies in the mountain areas in order to analyse the policy making processes in the tourist destinations and the role of the different stakeholders in this process / Analyse of the influence of each national context on the local/regional governance / Comparison of decision making processes in alpine resorts with the ones of other parts of the World (e.g. North America, Scandinavian countries) / Analysis of the relationship between certain features of local/regional governance and their influence in terms of sustainability (economy, ecology, society) for the tourist destinations.

**Actions:**

- Tourism / guest relevant co-operation of tourist destinations within the whole alpine region (marketing, product development, quality, events, nature-oriented tourism, etc.) under the aspects of co-operation management.
- International comparisons between case studies in different alpine countries

**Social Relevance, addressed stakeholders:** Recommendations for the local, regional and national authorities regarding the influence of local governance on the sustainable development of tourist destinations in the Alps / Better management of the destination through a better understanding of the relationship between private and public actors (tourist enterprises, local authorities, NGO's, etc.) / Learning from the experiences of other countries where the governance model in the resorts is more integrated (e.g. North America)

**6. Potentials and strategies of sustainable nature-based tourism and sports in the Alps**

**Rationale:** if nature-based and nature-sports tourism are recognised as “soft” or “slow” “tourism, their impact on alpine environment is increasing with their growing and diversification, both in winter and summer. Oscar Wilde aphorism “every one kills what he loves” is verified every day in spite of an inflation of “good practices guides”. In this context, concrete solutions have to be referred to a thorough study of perceptions of nature, ethic and mediation stakes involving literature, mountain press, nature and sports instructors.

**Research goals:** to better understand the recent and actual development, future potentials and success factors of nature-based tourism. to better understand conflict-resolution instruments as regards nature-based activities (nature sports) and natural heritages.

**Actions:**

- Promotion of the cooperation between tourism, nature and landscape protection and research institutions
- Transalpine Research Programme on nature-based tourism and nature sports
- Close-to-home nature-based tourism as a sustainable answer to manage leisure mobility
- Research projects:
- Critical review of 15 years of sustainable charters, labels and good practices guides in nature sports
- Perceptions of nature in nature-based and nature sports press and literature
- Proposal of methods and tools for mediation and dialog between professional operators (ski instructors, mountain guides, etc.) and protected areas
- Concerted action to integrate environmental ethics into sporting ethics
- Examination of solutions like Diary 21 including nature-based and nature-sports tourism

**Social relevance:** tendency of concentration of economic investments in competitive regions, so potentials of rural areas have to be highlighted and recognized / the increasing role of protected areas in nature-based and nature-sports management / the increasing number of conflicts between protected areas and mountain sports operators.

**Addressed Stakeholders:** Authorities for regional policy and development (European, national, regional); Protected Areas; Community Network Alliance in the Alps

### 7. Tourist transport infrastructures in mountain areas

**Rationale:** many tourist infrastructures developing mountain areas are in economic difficulties. It seems, that tourist infrastructures will concentrate more and more in some regions and expand from there into areas which are still undeveloped, mainly by linking several stations on both sides of mountain ranges. On the other hand, little and medium tourist stations cannot sustain their tourist infrastructure and will decrease or depend from larger tourist areas.

**Research goals:** trends in the development of high mountain areas have to be analysed from an economic and a social point of view, to understand processes of concentrations and extensions of tourist infrastructures. To understand these processes, an Alpine-wide spatial concept for tourist development in high mountain areas (remain undeveloped, status quo, extension) should be designed for political discussion.

**Actions:**

- Alpine-wide conference on tourist development of high mountain areas (CAA, ISCAR, etc.)
- Thematic focus of one of the meetings of the Standing Committee of the Alpine Conference
- Research projects on case studies (national, regional)
- Research project: basic information for the compilation of an Alpine-wide strategic map with different development of tourist infrastructures (none at all, status quo, possibly new)
- Research project: Who owns high mountain areas? Who can have properties? Who can decide on what?

**Social relevance:** undeveloped landscapes have to be preserved complementarily to areas developed for mass tourism, important areas for regeneration, areas without mass tourism.

**Addressed stakeholders:**

- Alpine Convention for thematic setting and leading transalpine discussion,
- Authorities in spatial planning (European, national, regional)
- Club Arc Alpin, national alpine clubs, hiker organisations (users of undeveloped high mountain areas)
- Tourist associations, cable car associations and other pressure groups

# Natural Disasters and Climate Change in the Alps

Gerhard Berz

University of Munich

Over the last few decades, the global community has been confronted with a drastic increase in the scope and frequency of major natural disasters. This trend is attributable primarily to the continuing steady growth of the world population and the increasing concentration of people and economic values in urban areas. Another factor is the global migration of populations and industries into areas such as coastal and alpine regions that are particularly exposed to natural hazards. The natural hazards themselves, on the other hand, are assuming ever more threatening dimensions as global warming continues to intensify many atmospheric extremes.

If the global warming predictions come true, the present problems will be magnified drastically. Changes in many atmospheric processes will significantly increase the frequency and severity of heat waves, droughts, bush fires, tropical and extra tropical cyclones, tornadoes, hailstorms, floods and storm surges in many parts of the world. In the alps, risks from flash floods, rock falls, landslides, avalanches, severe storms and forest fires will lead to more and heavier disasters. These events will inevitably have a profound impact on all types of property insurance as well as of health and life insurance.

## *Introduction*

The last thirty years or so have prompted growing concern among insurers in regard to the rapidly increasing burden of claims resulting from natural catastrophes. Because most of these losses had been caused by extremely powerful atmospheric phenomena such as windstorms, floods, heat waves and hailstorms, insurers soon began to suspect that the environmental and climatic changes observed throughout the world were playing an important role in this trend toward more frequent and more extensive disasters. Even though this correlation cannot easily be confirmed scientifically, there can be no doubt as to its plausibility and staggering significance. In planning and providing for the future, the political and financial world must take into account the likelihood that the expected climatic changes will further intensify this trend in catastrophic events, and weigh their consequences against the costs of implementing effective mitigation strategies.

*Trends in the frequency and severity of catastrophic events*

Particularly in the last few decades, the burden of claims resulting from natural catastrophes has taken on dramatic dimensions, especially for the insurance industry. Analysis of all the natural catastrophes that have cost the insurance industry more than US\$ 1bn, shows that prior to 1987, this threshold had been reached by only a single event, Hurricane Alicia of 1983. Since 1987, however, this figure has been surpassed by two more events in the 1980s, but no less than 28 in the 1990s and already 26 between 2000 and 2007. The new record holder, Hurricane Katrina in 2005, cost insured losses of approximately US\$ 60bn and some US\$ 125bn in economic losses.

Statistics of great weather-related natural catastrophes since 1950 reveal very clearly that there has been a dramatic increase in losses resulting from such catastrophes in recent decades (Munich Re 2008). Economic losses in the last decade (1998-2007) have increased by a factor of 7.2 over the 1960s level, and insured losses by even a factor of 27.2 (table 1). These figures reflect only the claims that are attributable to great weather disasters; all the other claims resulting from smaller events, of which Munich Re registers approximately 700-900 around the world each year, increase the volume of total losses substantially.

Table 1: Great weather catastrophes, 1950-2007. Decadal comparison, worldwide.

	Decade 1950-1959	Decade 1960-1969	Decade 1970-1979	Decade 1980-1989	Decade 1990-1999	last 10 1998-2007		
<b>Number</b>	15	16	29	44	74	41		
<b>Overall losses</b>	52.0	67.1	94.4	150.7	507.3	482.1		<b>Factor last 10:60s</b>
<b>Insured losses</b>	1.6	7.2	14.5	28.1	120.4	195.7		<b>2.6</b>
							<b>7.2</b>	
							<b>27.2</b>	

Losses in US\$ bn – 2007 values

© 2008 Munich Re, Geo Risks Research, NatCatSERVICE

As at January 2008

Certainly, these increases in losses are attributable in large part, or even for the most part, to increasing values and insured liabilities, particularly in conurbations in regions of high exposure (table 2, Munich Re 2000). Moreover, natural catastrophes have demonstrated repeatedly that buildings and infrastructures have become not less, but even more susceptible to damage, despite all building regulations and technological advances. This was shown very clearly by many recent earthquakes, storms and floods.

**The frequency and size of losses due to natural disasters are increasing dramatically all over the world**

*The reasons:*

- Rise in population
- Better standard of living
- Concentration of people and values in large conurbations
- Settlement in and industrialisation of extremely exposed regions
- Susceptibility of modern societies and technologies to natural hazards
- Increasing insurance density
- Changes in environmental conditions

*Table 2: Main reasons for the increase in natural catastrophes*

At the same time, however, there is an increasing body of evidence that the emerging climatic changes are influencing the frequency and intensity of natural catastrophes (Munich Re 2005). On the one hand, there are the major windstorm catastrophes of recent years, which have set new loss records and, on the other hand, there are the innumerable flood, tempest, drought and forest-fire catastrophes that seem to occur more frequently now than ever before.

In spite of these phenomena, the forth IPCC report (2007) still sees no general scientific proof of the correlation between global warming and the increased frequency and intensity of extreme atmospheric events. Many studies and simulations, however, have provided a good deal of evidence that the probabilities of various meteorological parameters reaching extreme values have already changed or will change significantly. Some examples are provided below:

The anticipated further increase in average temperatures causes an extraordinarily sharp rise in the probability of extremely high temperatures. For example, an increase of 1.6°C in central England’s average summer temperature, which is expected to occur by approximately 2050, will mean that a hot summer such as that of 1995 – which according to the 1961-1990 temperature distribution was a 75-year event – would then occur once every three years on average (figure 1, Dept. Environment 1996). Similarly, a heat wave like the one in summer 2003, which caused more than 70,000 deaths in Central and Western Europe, will probably become a rather normal summer situation in the last third of this century. Since we are currently in no way prepared for such heat waves, considerable adjustment costs and losses are to be expected.

In Central Europe, recent decades have brought significantly wetter winters and drier summers. A greater proportion of winter precipitation falls as rain, rather than

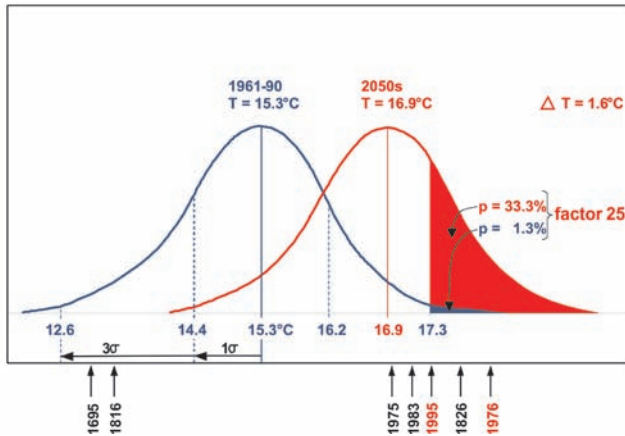

Fig. 1: Increasing Probabilities of Extremes. Example: Summer Temperatures in Central England. Source: Climate Change Impacts UK 1996

snow, with the consequence that most of it runs off before being absorbed. Evidence of increasing runoff quantities is provided by measurements from the Rhine basin and other major rivers. Global warming also increases the capacity of the air to absorb water vapour and thus the precipitation potential, as well. In conjunction with intensified convection processes, this will lead to ever more frequent and ever heavier downpours, which are already responsible for a large part of flood damage.

The milder winters that have meanwhile become typical of Central Europe have reduced the extent of the snow-covered areas, above which stable high-pressure zones of cold air used to form a barrier against low-pressure storm fronts approaching from the Atlantic. The barrier is therefore often weak or shifted far to the east, with the consequence that series of devastating gales such as occurred in 1990, 1999 and 2007 can no longer be considered rare and exceptional phenomena (figure 2, Dronia 1991).

Against the bleak backdrop of these dreaded changes, which are summarised in table 3, the crucial question is not whether or even when there will be conclusive

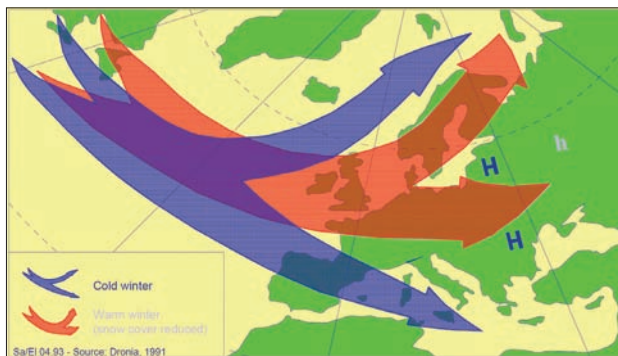
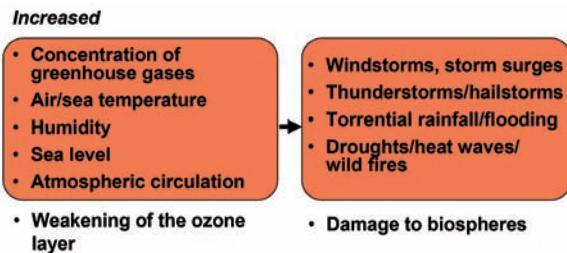

Fig. 2: European Winter Storm Tracks in Warm vs. Cold Winters (Dronia, 1991)

proof of anthropogenic climatic changes, but whether the climatic data and models used thus far offer an adequate basis for sensibly assessing future changes and developing appropriate adaptation and avoidance strategies in a timely fashion. Given the fact that the risk of error will remain great for the foreseeable future, it is all the more important that the strategies themselves be adaptable, and their results be measurable in terms of the losses that are to be avoided. Success is guaranteed from the start in the case of “no-regret” strategies such as measures to reduce the fuel consumption of motor vehicles or energy consumption in general because, even if the strategies prove to be less relevant to the climate than is currently supposed, they will in any case yield desirable savings and demonstrate the industrial nations’ awareness of their responsibility toward the Third World.

However, not all the effects of climatic change will necessarily be negative. In many countries in the temperate and subpolar latitudes, for example, there would be reason to expect increased agricultural yields and substantially reduced heating costs during the winter. On the other hand, regions closer to the equator will need more energy for cooling during the summer, and more frequent heat waves and droughts may be expected to cause additional losses.



*Table 3: Effects of climate change on weather extremes. The anthropogenic greenhouse effect increases the hazard of catastrophes.*

Recently, several attempts have been made to estimate the worldwide costs of anthropogenic climatic changes and to compare them to the costs of measures for bringing about lasting climatic stabilisation. The results are disturbing, as they indicate that climatic changes will trigger worldwide losses that could total trillions of US dollars per year or up to 20% of the global GDP, if nothing is done to curb the greenhouse gas emissions. In contrast, the costs of taking action now are lower by a factor of 10-20 and would mean for most countries, that they can expect their losses to range from a few per mille to a few per cent of their respective GDP each year, but even then certain countries – especially small island states - could face losses far exceeding ten per cent of their GSP (Stern 2006). These studies might now be able to convince even those governments and business enterprises that are still undecided or even oppose the framework agreement for a world climate convention reached in Rio de

Janeiro in 1992 as well as the climate protection strategies provided by the Kyoto Protocol 1997.

### *Consequences in the Alps*

Natural catastrophes in the Alps are dominated by weather extremes like windstorms, flash floods, heat waves and forest fires. Out of a total of 825 catastrophes recorded during the period 1980-2006 only 3% were caused by earthquakes, whereas almost all of the € 58 bn in economic losses, 20% of which were insured, occurred due to extreme weather (figure 3). Some major loss events are listed in table 4.

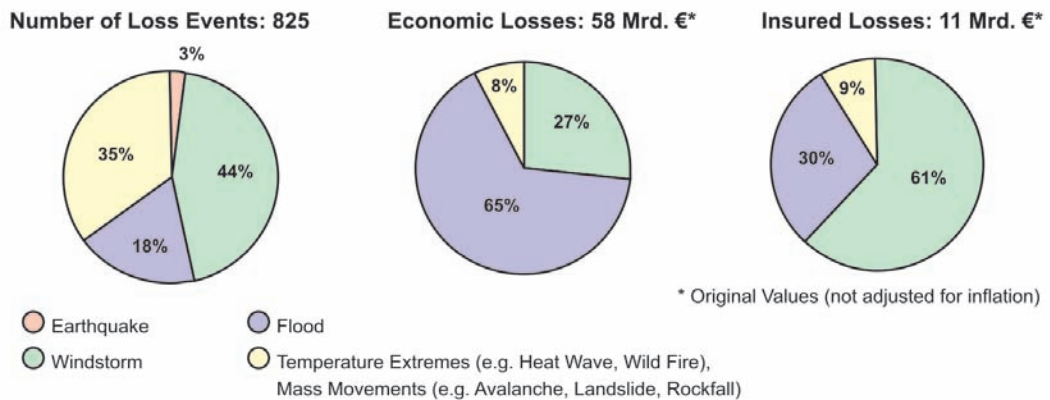

© 2007 Munich Re, Geo Risks Research, NatCatSERVICE

As at February 2007

Fig. 3: *Natural Disasters in the Alps, 1980 - 2006*

A quarter of a century is not sufficient to derive a representative picture of the catastrophe exposure of the alpine region. Nevertheless, this period seems to be quite typical with regard to the observed catastrophes. On the other side, several factors which are of critical influence on the frequency and effects of catastrophic events have changed so drastically during the last few decades that any comparison does not seem reasonable for longer periods.

Temperatures in the Alps have increased much faster (by some 2°C during the last century) than in central Europe (ca. 1°C) and worldwide (ca. 0.7°C). Similar to the polar regions the decreasing snow and ice cover leads to an increased absorption of solar radiation and, as a consequence, to a self-amplifying warming.

Combined with changing seasonal precipitation patterns (drier summers, wetter winters) and with increasing rainfall intensities due to a higher water vapour content in a warmer atmosphere as well as with rising snowfall and permafrost elevations a



Table 4: Major Loss Events in the Alps, 1980-2006

Date	Region	Event	Deaths	Economic Losses (Mio €)*	Insured
12.7.1984	Southern Germany	Hailstorm		950	480
18.-28.7.1987	Northern Italy (Veltlin)	Landslides, flash floods	44	625	0
July- Aug. 1987	Switzerland (Brig)	Flash flood	8	800	175
25.2.-1.3.1990	Alpine region	Winter storms	7**	700**	460**
Sept.- Oct. 1993	Switzerland	Flood	2	620	320
4.-6.11.1994	Northern Italy (Veltlin)	Flood	64	9,300	65
Jan.-March 1999	Alpine region	Avalanches, winter damage	108	850	150
1.5.1999	Germany, Switzerland	Flood	8	670	290
3.-7.7.2000	Austria	Hailstorms	2	125	70
14.-21.10.2000	Northern Italy, Switzerland	Flood	38	8,500	ca. 420
6.-7.7.2001	Southern Germany	Severe storms	6	300	200
7.-8.7.2001	Northern Italy	Severe storms, tornado		175	30
3.8.2001	Southern Germany	Severe storms, Hailstorm		300	200
Aug.02	Southern Germany, Austria, Italy	Floods, severe storms, hailstorms	30	10,000	1,000
Aug.03	Austria, Switzerland, Italy, France	Severe storms, land slides, heat wave	5	500	5
20.-27.8.2005	Switzerland, Germany, Austria	Floods	11	2,500	1,400
Feb. 2006	Austria, Germany	Winter damage	3	650	290

© 2007 Münchner Rückversicherungs Gesellschaft, GeoRisikoForschung, natCatSERVICE

\* Original Values

\*\* Austria and Switzerland

very substantial aggravation of a number of catastrophe risks and of the resulting catastrophe scenarios will take place (figure 4). This disastrous trend will endanger the economical, ecological and social development of the alpine region through some extraordinary loss potentials in densely populated areas. These problems can only be solved or at least mitigated, if rapid and sustainable counter-measures are introduced to stabilise the climate and, at the same time, to adapt timely enough to the unavoidable environmental changes, e.g. through respective land use planning and construction codes. Precautionary measures are of vital importance also in many other sectors like the power industry, agriculture, tourism and insurance.

### *Concluding remarks*

The frequency and scope of loss of major natural catastrophes will continue to increase dramatically throughout the world. Unless drastic measures are taken soon to prevent it, this trend will be intensified considerably by the ever more evident warming of the atmosphere, the resultant increase in sea level, and the intensification of storm and precipitation processes.

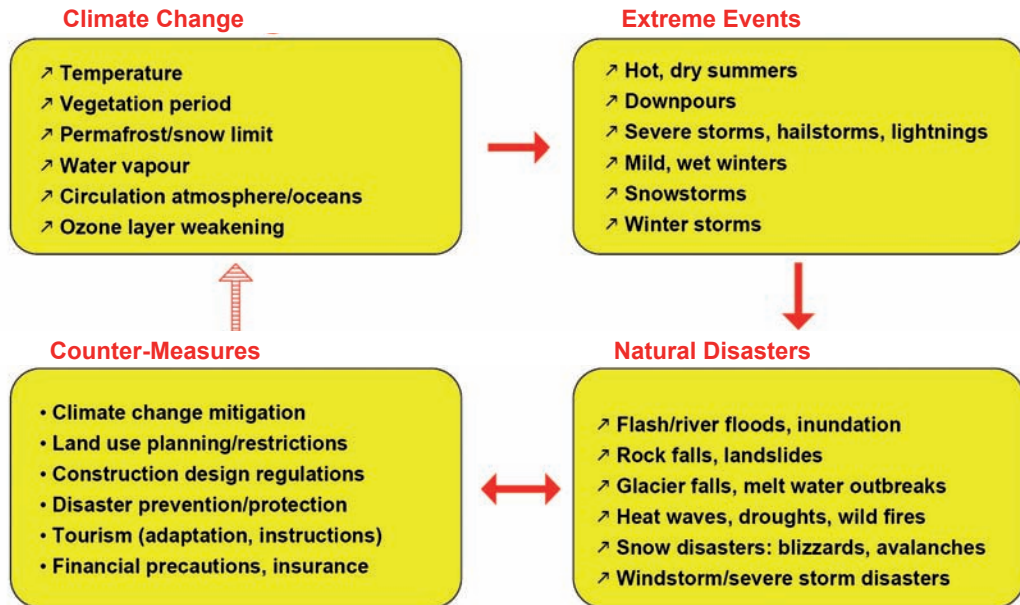

Fig. 4: Climate Change and Natural Disasters in the Alps

In its own interest, the insurance industry must assume a major role in implementing preventive measures in order to ensure that it can provide cover for natural hazards over the long term. By designing insurance products appropriately, the insurance industry can motivate not only policyholders, but even government agencies to adopt loss-prevention and -minimisation measures and thus also reduce its own loss potentials.

### References

- Dronia, H. (1991) Zum vermehrten Auftreten extremer Tiefdruckgebiete über dem Nordatlantik in den Wintern 1988/89 bis 1990/91. Die Witterung in Übersee 39, 3, 27.
- Department of the Environment (1996) Review of the Potential Effects of Climate Change in the UK. HMSO, London, 50 pages.
- Munich Reinsurance Company (2000) World of Natural Hazards, CD-ROM. Munich Re, Munich.
- Munich Reinsurance Company (2005): Weather Catastrophes and Climate Change. Knowledge Series. Munich Re, Munich, 264 pages.
- Munich Reinsurance Company (2008): Annual Review of Natural Disasters 2007. Topics, Munich Re, Munich, 50 pages.
- Stern, N. (2006): The Stern Review on the Economics of Climate Change. London, 700 pages.

# Supply and Demand for Ecosystem Services in Mountainous Regions

Thomas Koellner

Research group *Ecosystem Services* at NSSI-ETH Zurich

While ecosystems deliver goods and services of enormous value to the human society (Pearce and Moran 1994, Daily 1997), intensive land and water use, extraction of natural resources, and chemical emissions into the environment are leading to a worldwide loss of biodiversity and degradation of ecosystem functioning (Hooper et al. 2005, Millennium Ecosystem Assessment 2005). Climate change has intensified the dynamics of this human-environment interaction, which is more severe in mountain regions compared to the lowlands (see Körner this volume). Because of topographical complexity and altitudinal gradients mountain ecosystems are particularly sensitive to global change compared to the lowland (Becker et al. 2007, Bugmann et al. 2007). However, the lowlands are also heavily influenced by undesired changes in mountain areas, because of their importance for biodiversity and for providing ecosystem services. Downstream actors benefit from clean water, flood control, reduced sedimentation, scenic beauty and many more positive mountainous ecosystem services.

By definition ecosystem services are functions of nature with value for the human wellbeing.<sup>1</sup> This polarity between nature and human well-being implies that it is essential to understand the interdependences between the ecological system and the socio-economic system (Figure 1). We use the concept of human-environment systems in sensu Scholz (2003) as the rationale for the research program. This allows studying the supply and demand for ecosystem services in an integrated manner.

---

1 This simple definition is not completely in line with that of the Millennium Ecosystem Assessment (MA), which defines ecosystem services as the “benefits people obtain from ecosystems”. The difference in the two definitions is that the MA claims that food, water, timber and fiber are also ecosystem services. I would rather say it is not the commodity from forestry and agriculture, which is the service, but the function of nature to *produce* such commodities. Anyway, currently there is much confusion around the exact definition of ecosystem services (see Boyd 2007, Boyd and Banzhaf 2007, Wallace 2007, Costanza 2008).

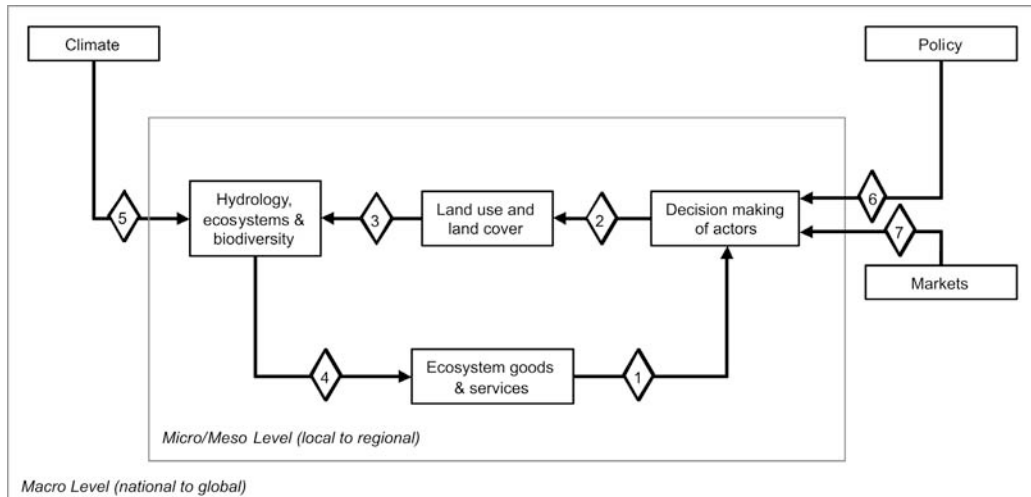

Figure 1: Conceptual framework of a research program on supply and demand for ecosystem services. (1) Effects of changes of ecosystem goods and services on the decision-making of actors demanding ecosystem services in a regional socio-economic system. (2) “Decision-making” of actors implies changes in land use and land cover. (3) Effects of changes to land use/ land cover on regional hydrology, ecosystems and biodiversity. (4) Effects on the ecosystem goods and services supplied. (5), (6) and (7) describe exogenous variables, which influence the modeled system, especially (5) effects of changes in climate on regional ecosystems, (6) Effects of developments in policy on decision-making and (7) effects of developments in (financial and trade) markets on decision-making.

Within this general framework for human-environment systems three main objectives of the research on *Ecosystem Services* would be

- A) to model land and water use and its impact on biodiversity and ecosystem services regionally, given scenarios of global change (i.e., changes of climate, markets and policies);
- B) to analyze the decision-making that drives supply and demand for ecosystem services, and
- C) to explore national and international payments for ecosystem services (PES) and their linkages to the financial sector.

Improving knowledge related to these three objectives is important to develop strategies for the adaptive and sustainable management of ecosystems services. The research results of such a program should inform and support policy-makers and ecosystem managers. For example, probabilistic and spatial models that quantify

land use/land cover, levels of biodiversity, and intensity of ecosystem services for various global change scenarios can be implemented as decision support tools by ecosystem managers or decision-makers in policy and industry. Similarly, the factors (cost-benefit expectations, norms, and behavioral control), which influence the decisions made by supply and demand side actors should be understood and taken into account in designing new policy instruments like PES schemes as well as “green” financial products.

### *A) Modeling land use, biodiversity and ecosystem services facing global change*

Many ecological economic models exist to understand the complex interdependencies between land use, biodiversity and ecosystem services under global changes of climate, markets and policies. They were developed to investigate ecological factors, economic decision-making and land use/land cover change on a landscape scale (see review in Baker 1989, Irwin and Geoghegan 2001, Bell and Irwin 2002, Heistermann et al. 2006) and the interdependency of trade, land use, biodiversity and environmental impacts on a global scale (Polasky et al. 2004, Mayer et al. 2005, Würtenberger et al. 2006).

Complemented with knowledge on hydrology, ecological economics models were used to investigate land use, (forest) ecosystem status and hydrological services in watersheds (Voinov et al. 1999, Bergh et al. 2004, Bruijnzeel 2004, Hörmann et al. 2005, Wattenbach et al. 2005). In the field of impact assessments of climate change and land use on ecosystems and economies such models considered the impacts from changing climatic variables on vegetation pattern and biodiversity (Ostendorf et al. 2001, Parmesan and Yohe 2003, Thomas et al. 2004), impacts of land use on biodiversity (Gaston et al. 2003), impact of global change on ecosystem services (Alcamo et al. 2005, Schröter and et al. 2005, Metzger et al. 2006), and the cascading effects from changing climatic variables, to land use, ecosystem impacts, economic consequences and policy implications (e.g. MINK model Dowlatabadi and Morgan 1993, Rosenberg 1993, Krysanova et al. 1999). Reversely, also the impact of policy interventions on farm level income and the environment in watersheds was modeled (Barbier and Bergeron 1999, Lant et al. 2005), however, not yet the link to ecosystem services.

In those models land-users’ decision-making and behavior is normally explained with economic rationality based on expected profits and opportunity costs (e.g.,

Nieuwenhuysen et al. 2000), but neglect other factors, which explain behavior of land users. The People and Landscape Model (PALM) has made effort towards full integration of human decision-making and biophysical simulation models (Mathews 2006).

Meanwhile the idea of ecosystem services has also reached environmental accounting tools, which support decision makers. Two prominent tools are the Life Cycle Assessment, which quantifies environmental impacts of products and companies, and Green National Accounting, which puts the value of natural resources on the accounting sheets of nations. In the past, Life Cycle Assessment did focus mainly on land use impacts of biodiversity (Koellner and Scholz 2007, Koellner and Scholz 2008), but impacts on ecosystem services will be quantified soon<sup>2</sup> (see Koellner 2003 for conceptual framework). With respect to Green National Accounting it is currently discussed how ecosystem services can be taken into account (Weber 2007, Mäler et al. 2008).

### *B) Analyzing the actors' decision-making related to ecosystem services*

In recent years many market based instruments to the management of ecosystem services emerged. Little is however understood about the decision-making process of suppliers and demanders of ecosystem services. The work of Sell (Sell et al. 2006, Sell et al. 2007, Sell et al. submitted) has filled this gap and has analyzed the expected benefits and market potentials of ecosystem services from tropical forestry, particularly focusing on the perception of international market actors. The three surveys suggest that the decision-theoretic combination of criteria, preferences and expected benefits is a useful approach to analyze the decision making of market actors. The surveys indicate that the perspective and decision making differ between market actors of tropical and non-tropical countries, with the former having a business and the latter tending to have a sustainability focus. Yet, similar studies for the relationship of lowland and mountains are missing.

Because the private sector is a beneficiary of such ecosystem services a large survey of over 900 international and Costa Rican companies was implemented to investigate their demand for ecosystem services from tropical forests (Koellner et al. in prep.). The results showed that international companies are interested in buying

---

2 Current project under the UNEP/SETAC Life Cycle Initiative entitled Operational Characterization Factors for Land use Impacts on Biodiversity and Ecosystem Services in the Life-Cycle Impact Assessment. LULCIA

certificates mainly for carbon sequestration; Costa Rican companies, for all four ecosystem services in the following order: watershed protection, biodiversity conservation, carbon sequestration, and scenic beauty. This information about factors driving demand was used to develop concepts for marketing ecosystem services (Gähwiler 2004, Gähwiler et al. submitted).

*C) Exploring the links between ecosystem services and the financial sector*

It is of the highest relevance for sustainable ecosystem management to link the provision of biodiversity and ecosystem services (being a positive externality) to public and private payments. For that reason much work was done on Payments for Ecosystem Services (PES) in the past (see the special issue on that topic by Engel et al. 2008). Especially, in Costa Rica—the birthplace of the PES idea—research did focus on identifying spatial priorities for ecosystem services in order to support national authorities to distribute payments more efficiently (Chan et al. 2006, Wünsch et al. 2007, Imbach et al. submitted). PES schemes are explicitly designed around ecosystem services, however, payments for biodiversity and ecosystem services can be also implement in existing fiscal instruments (Koellner et al. 2002, Ring 2002). Another current trend is that Payments for Ecosystem Services are put into an international context (Koellner and Engel 2008). On the one hand this clearly is relevant for “global” ecosystem services like carbon sequestration, but also for services like flood regulation, which can cross national borders, when beneficiaries downstream are situated in the next country. On the other hand, this concept allows integrating not only downstream users of ecosystem services in a physical sense, but also foreign beneficiaries, which financially benefit from ecosystem services in a given region. For example, regions with intact ecosystem services potentially can have a price advantage in the production of agricultural commodities (e.g., pollination services impacts coffee growing in mountainous regions). This price advantage can trickle through the global value chain linking producers and consumers internationally. However, this effect was not investigated yet.

Payments for Ecosystem Services can have a significant influence on global environmental change, but traditional financial markets have due to their sheer market volume the potential to even more strongly influence global ecosystems. For this reason Koellner (2008) reviewed financial market innovations, which integrate sustainability and natural resource management. Environmental commodi-

ties like biodiversity and ecosystem services were explicitly included in the analysis. The analysis embraced all types of financial markets ranging from conventional commodity markets, environmental commodity markets, capital (stocks & bonds) markets, real estate markets, to insurance markets. Actors in all those markets in fact proved to be quite innovative in developing new financial products based on the sustainable production of soft commodities—like timber and food—as well as of environmental commodities—like clean water, clean air, biodiversity or ecosystem services. For example, small loans to farmers or forest owners, which comply with sustainability criteria and thus have positive influence on ecosystem services, can be securitized as micro credit funds and are traded on formal exchanges (e.g., in Costa Rica FONAFIFO was planning to issue a forest credit fund backed by the World Bank, <http://www.fonafifo.com>). Although this is a rather indirect influence on ecosystem services such instruments can have substantial impacts on ecosystems in a given region.

### *Conclusion*

This by far not complete review of research covering the supply and demand for ecosystem services makes clear that the topic is widely covered and many facets are intensively investigated. However, especially when it comes to mountainous ecosystem services it becomes clear that there are still important research gaps. To identify this gap a workshop on supply and demand for ecosystem services was organized during the COST conference (see this volume). What is especially missing is that mountain ecosystems are not clear enough conceptualized in the relationship to their lowlands. For that reason analyzing disparities between mountain regions and lowland regions with respect to level and rates of change of ecosystem services as well as disparities in wealth and well-being of the people are an important research goal. This together with the modeling of impacts of global change needs to be the basis for adaptive land use planning and optimization. Until now much was done to model global *environmental* change, but the impacts of socioeconomic changes are still an open field. Only, when those factors are clearly understood it is possible to design instruments in the private and public sector to address unsustainable development. Such a research program clearly requires interdisciplinary and transdisciplinary research.



*Literature cited*

- Alcamo, J., van Vuuren, D., Ringler, C., Cramer, W., Masui, T., Alder, J. and Schulze, K. (2005) Changes in nature's balance sheet: Model-based estimates of future worldwide ecosystem services. *Ecol Soc.* 10(2), 19.
- Baker, W. L. (1989) A review of models of landscape change. *Landscape Ecology* 2, 111-133.
- Barbier, B. and Bergeron, G. (1999) Impact of policy interventions on land management in Honduras: results of a bioeconomic model. *Agricultural Systems* 60, 1-16.
- Becker, A., Körner, C., Brun, J. J., Guisan, A. and Tappeiner, U. (2007) Ecological and Land Use Studies Along Elevational Gradients. *Mountain Research and Development* 27, 58-65.
- Bell, K. P. and Irwin, E. G. (2002) Spatially explicit micro-level modelling of land use change at the rural-urban interface. *Agricultural Economics* 27, 217-232.
- Bergh, J. C. J. M., van den, Barendregt, A. and Gilbert, A. J. (2004). *Spatial Ecological-Economic Analysis for Wetland Management*. Cambridge Univ Press: Cambridge.
- Boyd, J. (2007) Nonmarket benefits of nature: What should be counted in green GDP? *Ecological Economics* 61, 716-723.
- Boyd, J. and Banzhaf, S. (2007) What are ecosystem services? The need for standardized environmental accounting units. *Ecological Economics* 63, 616-626.
- Bruijnzeel, L. A. (2004) Hydrological functions of tropical forests: not seeing the soil for the trees? *Agriculture, Ecosystems and Environment* 104, 185-228.
- Bugmann, H., Gurung, A. B., Ewert, F., Haeberli, W., Guisan, A., Fagre, D. and Kääb, A. (2007) Modeling the Biophysical Impacts of Global Change in Mountain Biosphere Reserves. *Mountain Research and Development* 27, 66-77.
- Chan, K. M. A., Shaw, M. R., Cameron, D. R., Underwood, E. C. and Daily, G. C. (2006) Conservation Planning for Ecosystem Services. *PLoS Biology* 4, 1-15.
- Costanza, R. (2008) Ecosystem services: Multiple classification systems are needed. *Biological Conservation* 141, 350-352.
- Daily, G. C., ed (1997) *Nature's Services. Societal Dependence on Natural Ecosystems*. Washington, D.C., Covelo, California, Island Press.
- Dowlatabadi, H. and Morgan, M. G. (1993) Integrated assessment of climate change. *Science* 259, 1813, 1932.
- Engel, S., Pagiola, S. and Wunder, S. (2008) Designing payments for environmental services in theory and practice: An overview of the issues. *Ecological Economics* 65, 663-674.
- Gähwiler, M., (2004). *Marketing of Ecosystem Services in Tropical Forestry*. Master thesis, Zurich, NSSI, ETH-NSSI.
- Gähwiler, M., Gross, B., Koellner, T., Proctor, W. and Zilberman, D. (submitted) *Marketing Ecosystem Services*. In Edited by P. Kumar and Muradian, R., *Payments for Ecosystem Services* Oxford University Press: India.
- Gaston, K. J., Blackburn, T. M. and Goldewijk, K. K. (2003) Habitat conversion and global avian biodiversity loss. *Proc. R. Soc. Lond. B* 270, 1293-1300.

## Global Change and Sustainable Development in Mountain Regions

- Heistermann, M., Müller, C. and Ronneberger, K. (2006) Land in sight? Achievements, deficits and potentials of continental to global scale land-use modeling. *Agriculture, Ecosystems and Environment* 114(2-4), 141-158
- Hooper, D. U., Chapin, F. S., Ewel, J. J., Hector, A., Inchausti, P., Lavorel, S. et al. (2005) Effects of biodiversity on ecosystem functioning: A consensus of current knowledge. *Ecological Monographs* 75, 3-35.
- Hörmann, G., Horn, A. and Fohrer, N. (2005) The evaluation of land-use options in mesoscale catchments. Prospects and limitations of eco-hydrological models. *Ecological Modelling* 187, 3-14.
- Imbach, P., Pedroni, L., Alpízar, F. and Koellner, T. (submitted) Spatial priorities for the Payment of Ecosystem Services (PES) in Costa Rica.
- Irwin, E. G. and Geoghegan, J. (2001) Theory, data, methods: developing spatially explicit economic models of land use change. *Agriculture, Ecosystems and Environment* 85, 7-23.
- Koellner, T. (2003). *Land Use in Product Life Cycles and Ecosystem Quality*. Peter Lang: Bern, Frankfurt a. M., New York.
- Koellner, T. (2008) Trading on Scarcity: Ecological Progress and Financial Market Innovations. Input Paper for 9th International Sustainability Leadership Symposium 2008 "Capitalising on Natural Resources: New Dynamics in Financial Markets". 10 / 11 September 2008, Swiss Re Centre for Global Dialogue, Rüschlikon/Zürich, Switzerland.
- Koellner, T. and Engel, S. (2008) Globale Finanzinstrumente für Ökosystemdienstleistungen. *Die Volkswirtschaft* 7/8, 60-62.
- Koellner, T., Schelske, O. and Seidl, I. (2002) Integrating biodiversity into intergovernmental fiscal transfers based on cantonal benchmarking: a Swiss case study. *Basic and Applied Ecology* 3, 381-391.
- Koellner, T. and Scholz, R. (2007) Assessment of land use impacts on the natural environment. Part 1: An analytical framework for pure land occupation and land use change. *International Journal of LCA* 12, 16-23.
- Koellner, T. and Scholz, R. (2008) Assessment of land use impacts on the natural environment. Part 2: Generic characterization factors for local species diversity in Central Europe. *International Journal of LCA* 13, 32-48.
- Koellner, T., Sell, J. and Navarro, G. (in prep.) Why and how much pay firms for ecosystem services from tropical forests? A comparison of international and Costa Rican companies.
- Krysanova, V., Wechsung, F., Becker, A., Poschenrieder, W. and Gräfe, J. (1999) Mesoscale ecohydrological modelling to analyse regional effects of climate change. *Environmental Modeling and Assessment* 4, 259-271.
- Lant, C. L., Kraft, S. E., Beaulieu, J., Bennett, D., Loftus, T. and Nicklow, J. (2005) Using GIS-based ecological - economic modeling to evaluate policies affecting agricultural watersheds. *Ecological Economics* 55, 467-484.
- Mäler, K. G., Aniyar, S. and Jansson, A. (2008) Accounting for ecosystem services as a way to understand the requirements for sustainable development. *Proc Natl Acad Sci US A*.
- Mathews, R. (2006) The People and Landscape Model (PALM): Towards full integration of human decision-making and biophysical simulation models. *Ecological Modelling* 194, 329-343.

## Supply and Demand for Ecosystem Services in Mountainous Regions

- Mayer, A. L., Kauppi, P. E., Angelstam, P. K., Zhang, Y. and Tikka, P. M. (2005) Importing timber, exporting ecological impact. *Science* 308, 359-360.
- Metzger, M. J., Rounsevell, M. D. A., Acosta-Michlik, L., Leemans, R. and Schröter, D. (2006) The vulnerability of ecosystem services to land use change. *Agriculture, Ecosystems and Environment* 114, 69-85.
- Millennium Ecosystem Assessment (2005). *Ecosystems and Human Well-being: Synthesis*. Island Press: Washington, DC.
- Nieuwenhuysse, A., Hengsdijk, H., Bouman, B. A. M., Schipper, R. A. and Jansena, H. G. P. (2000) Can forestry be a competitive land use option? Model simulations from humid tropical Costa Rica. *Forest Ecology and Management* 137, 23-40.
- Ostendorf, B., Hilbert, D. W. and Hopkins, M. S. (2001) The effect of climate change on tropical rainforest vegetation pattern. *Ecological Modelling* 145, 211-224.
- Parmesan, C. and Yohe, G. (2003) A globally coherent fingerprint of climate change impacts across natural systems. *Nature* 421, 37-42.
- Pearce, D. and Moran, D. (1994). *The economic value of biodiversity*. Earthscan: London.
- Polasky, S., Costello, C. and McAusland, C. (2004) On trade, land-use, and biodiversity. *Journal of Environmental Economics and Management* 48, 911-925.
- Ring, I. (2002) Ecological public functions and fiscal equalisation at the local level in Germany. *Ecological Economics*. 42, 415-427.
- Rosenberg, N. J. (1993) A methodology called 'MINK' for study of climate change impacts and responses on the regional scale. *Climatic Change* 24, 1-6.
- Scholz, R. W. and Binder, C. R. (2003) *The Paradigm of Human-Environment Systems*. Working Paper No. 37. Natural and Social Science Interface, Institute for Human Environment Systems. Department of Environmental Sciences, Swiss Federal Institute of Technology Zürich (ETH), Switzerland Working Paper No. 37.
- Schröter, D. and et al. (2005) Ecosystem service supply and vulnerability to global change in Europe. *Science* 310, 1333.
- Sell, J., Koellner, T., Proctor, W., Weber, O. and Scholz, R. W. (submitted) Expected benefits and market potentials of ecosystem services from tropical forestry – The perception of international market actors.
- Sell, J., Koellner, T., Weber, O., Pedroni, L. and Scholz, R. W. (2006) Decision criteria of European and Latin American market actors for tropical forestry projects providing environmental services. *Ecological Economics* 58, 17-36.
- Sell, J., Koellner, T., Weber, O., Proctor, W., Pedroni, L. and Scholz, R. W. (2007) Ecosystem services from tropical forestry projects – The choice of international market actors. *Journal of Forest Policy and Economics* 9, 496-515.
- Thomas, C. D., Cameron, A., Green, R. E., Bakkenes, M., Beaumont, L. J., Collingham, Y. C. et al. (2004) Extinction risk from climate change. *Nature* 427, 145-148.
- Voinov, A., Costanza, R., Wainger, L., Boumans, R. M. J., Ferdinando, V., Maxwell, T. and Voinov, H. (1999) Patuxent landscape model: integrated ecological economic modeling of a watershed. *Environmental Modelling & Software* 14, 473-491.

## Global Change and Sustainable Development in Mountain Regions

- Wallace, K. (2007) Classification of ecosystem services: Problems and solutions. *Biological Conservation* 139, 235-246.
- Wattenbach, M., Hattermann, F., Weng, R., Wechsung, F., Krysanova, V. and Badeck, F. (2005) A simplified approach to implement forest eco-hydrological properties in regional hydrological modelling. *Ecological Modelling* 187, 40-59.
- Weber, J. L. (2007) Implementation of land and ecosystem accounts at the European Environment Agency. *Ecological Economics* 61, 695-707.
- Wünscher, T., Engel, S. and Wunder, S. (2007) Spatial targeting of payments for environmental services: A tool for boosting conservation benefits. *Ecological Economics* forthcoming.
- Würtenberger, L., Koellner, T. and Binder, C. R. (2006) Virtual land use and agricultural trade: Estimating environmental and socio-economic impacts. *Ecological Economics* 57, 679-697.

# Global Changes and Economic Globalization in the Andes. Challenges for Developing Nations

Hugo I. Romero, Pamela Smith and Alexis Vasquez

Departamento de Geografía, Universidad de Chile, Santiago de Chile

## *1. Introduction*

Global changes are a very relevant issue for the whole world, but especially for developing countries that depend mainly on their natural resources to sustain their economic and social development. In the case of the Andes, most of the Latin-American countries source their raw materials, biological goods and environmental services from this mountain chain (IGM, 1983). Before the Spanish colonization that started in XV century, natural resources were used for the development of local territories, but with the establishment of colonial centres they were sent to the metropolis, thus forming the first economic and cultural globalization process.

Today for the first time global changes, such as climate change and economic globalization, challenge simultaneously the subsistence of many ecosystems, regions and places in Latin America. The Andes is a very diverse, complex and fluid environment. In this essay we deal with the Chilean part of this mountain chain, i.e. a section of the Central Andes (Northern Chile) and Southern Andes (Chilean Patagonia). These regions could be understood as a good representation of the present interaction between global changes and global economy that is taking place.

Chile is one of the longest countries in the world, extending for more than 4.500 km, from subtropical (18 °S) to temperate and sub-Antarctic latitudes (56 °S). The northern section of Chile contains the Atacama desert, one of the driest ecosystems and regions in the world (Romero, 1983). The availability of water is the most critical natural resource for the development of this part of the country. Paradoxically, however, the Atacama desert is, at the same time, the most important reserve, on a global scale, of highly sought minerals for industrial development, like copper and molybdenum. Chile supplies almost 40 % of the global demand for copper, and in order to produce this amount of ore and to satisfy the increasing international market, enormous amounts of water quantities are required. Providing them is almost impossible in this very arid environment (Ibañez & Pizarro, 2003).

Difficulties for development that affect Northern Chile are typical for the environmental constraints that sustainable development is confronted with in many developing countries. Chilean society is expecting the international scientific community to contribute to finding a solution to these challenges.

Patagonia in Southern Chile represents different environmental conditions from those in the Atacama Desert. There the Andes reach the Pacific Ocean at latitudes where westerly winds predominate throughout the year. High rates of annual rainfall are responsible for the extraordinary quantity and quality of water which is stored in many glaciers and in two immense glacier fields or deposited along thousand of rivers, streams and lakes. Temperate rainforests, clean air, soils and waters, and a high biodiversity, located in orographically complex landscapes have been maintained up to now far away from human influence. Pristine ecosystems abound, especially in remote areas that were declared nature conservation areas many decades ago.

Clean water in Chilean Patagonia becomes a critical resource for future sustainable development, taking into consideration the generalized scarcity of resources in the country. Climate change is already reducing the annual mean rainfall by 50% in the southernmost section of Chilean Patagonia, mean and minimum temperatures are increasing, snowlines are rising and glaciers are retreating. These days economic activities, such as aquaculture and salmon farming, tourism and hydropower generation are competing for the control and appropriation of the most productive regional watersheds.

In both cases, mining installations and operations in Northern Chile and the competition for water from several economic sectors in Southern Chile, scientific knowledge is required to support the decision-making process. Unfortunately, scientific knowledge is a social resource that is currently not available, at least as a public good that could be accessed by the general people and the local communities.

An erroneous decision strongly supported by economic drivers could result in severe damages and devastation of natural and cultural landscapes. Probably, when Chile will suffer the most relevant effects of climate change in the future, its environmental landscapes will have already become completely devastated.

## *2. The Chilean Andes*

The Chilean Andes illustrate the extraordinary ecological diversity of this mountain chain. In the Atacama desert, aridity and water scarcity is a general pattern, but with

many differences according to ecological altitude belts, aspect and exposition to air masses. Even under the most arid conditions, oases, valleys, salt lakes and lagoons can be found, playing an important role in terms of habitability, concentrating available waters. Biological and human traditional communities have developed long-term spatial structures to complement natural resources and cope with ecosystem services diversity, and seasonal and annual uncertainties.

Available ground water – which is increasingly the most important source in Northern Chile – was stored under different climate, soil and vegetation conditions and at different places. While the core of the desert has always been a very arid environment, the highlands have experienced large climatic variations over time. Today these interannual changes in rainfall are mainly controlled by the El Niño-La Niña/Southern Oscillation. It is difficult to expect large climate changes in the future in this already arid environment. Ground and superficial waters will become a more critical constraint for the survival of biological species and native people. The current issue for the survival of Andes highlands in many areas is the persistent and increasing establishment of mining projects that need increasing amounts of water to sustain their production, but also to maintain all the related economic activities, such as urban functions and services that need to be provided by modern large cities.

The Chilean government has tried to protect the mountain sources of water, establishing national parks and nature reserves around the highland's main lakes and lagoons. For people concerned about nature conservation, these areas are not sufficient to represent the variety of highland ecosystems of the arid Andes. On the other hand, in many of these conservation areas, native people have settled for thousand years, and have developed their cultural and social practices. Native people have steadily complained against governmental appropriation of lands and water resources that they consider have always belonged to them. Many public authorities think that water is misused by native and traditional farmers and should be assigned for more profitable activities such as mining and urban consumption. Historically, the capture and diversion of water sources have forced local populations to emigrate once they had lost control and ownership of water in the middle of the desert. New mining development has added a very powerful actor to the conflict over land and water property and management in the north-Chilean Andes.

During the Pinochet dictatorship (1973-1990) a special water code was passed and water became a commercial good. From 1981 water rights could be purchased and sold without public restrictions in Chile. Although theoretically water rights

keep the public ownership, in fact they constitute private property because they are perpetually allocated, even if they have never been used or never will be used. On the other hand, these water rights could be exchanged separately from the land. As a consequence, between 1981 and 1990 many local communities lost their water sources. It was not until a new law was passed under a democratic regime in 1991 and aimed at protecting native people, that the complete sell-off of water rights in this part of the Andes was stopped. Only an adequate exchange of knowledge about the high social, ecological, cultural and environmental costs that have been paid by local communities could avoid a repetition of this practice in other Andean places.

An extraordinary diversity of mountain landscapes can also be found in the Southern Andes, especially between slopes exposed to or protected from rainfalls. While Western slopes receive and accumulate large amounts of precipitation resulting in a very wet landscape, there is a clear leeward gradient towards substantially reduced humidity across a very short distance, resulting in a semi-arid region. Glaciers and snow cover most of the Andean peaks and many rivers and lakes connect highlands with numerous lowlands of valleys, fjords and canals.

At the beginning of the 20th century, hundreds of thousands of hectares of rainforest and shrubs were burned in an attempt to introduce livestock and agriculture in unsuitable lands, resulting in soil erosion. Limited available resources and degrading of ecosystems, together with the isolated location have limited the small and autarchic population that lives in concentrated and unconnected settlements. 95% of the regional land belongs to the state and 50% is under nature protection, either as national parks, natural reserves or national monuments. However, most of these conservation areas are completely abandoned and unconnected because the scarce material, human and technological resources made available by public institutions. The Chilean Patagonia that administratively belongs to the Aysen (or XI) region remains mainly as near-natural landscapes, and in some areas, even as virgin ecosystems (Borsdorf 1987).

As a result of the small population that inhabits this region, clean air, water and soils could be found in most places. In fact, the regional slogan used by the authorities and people to promote development, has been “Aysén, a life reserve for humanity”.

However, today, like in the case of Northern Chile, water is becoming a strategic resource, especially water coming from glaciers and ice fields, which, even if they are retreating, would still support heavy and stable discharges compared with other Chilean reserves. Currently Chile is confronting a serious lack of energy because



this country lacks oil deposits and has not invested enough in the development of alternative energy sources such as wind and solar power that are very abundant in its longer coastal zones and in the Atacama desert, respectively.

Foreign and national hydropower companies are interested in establishing a series of projects in natural landscapes of Patagonian rivers such as Baker and Pascua, with many others to follow. On the other hand, the salmon farming industry – Chile is the second most important producer worldwide – is also interested in the use of lakes, rivers, fjords and canals in the coastal zone. The pressure from the salmon industry is rather bigger because currently several diseases are affecting farms concentrated further north. The industry needs new locations in isolated and pristine landscapes such as those offered by this southern region.

Apart from the potential conflict between nature conservation, hydropower installations and salmon farms, tourism is another economic sector afraid that their expectations are in jeopardy. International tourism is beginning in these isolated regions. An increasing number of tourists are looking for natural places to satisfy their interests, such as fly fishing, ecological safaris, adventures, rafting, trekking, or simply nature observation. One controversial point relates to the conflict between the goals and features of unique natural places of national parks and natural reserves, and dams or transmission lines for hydropower generation and transportation. This controversy has been especially voiced by international environmental organizations and by foreign entrepreneurs, like Douglas Topkins, who has bought several hundred thousand hectares of regional lands for nature conservation and tourist development purposes.

Conflicts between public and private use of resources can be observed all over Chile after thirty years of extreme application of liberal economic and political ideas. Unlimited exploitation of natural resources and increasing threats to nature conservation areas are important and controversial issues. Public policies seem to be more interested in attracting productive investments than to protect natural goods and services. The privatization and commoditization of territories and their natural resources, fiercely pursued by global economic financial and economic organizations, and the strict adherence to corporate objectives, are powerful obstacles for public policies and institutions that try to protect local ecosystems and social communities.

The high priority given to economic and financial objectives in Chile is preventing an alternative look at nature and the environment from a non-exploitative point of view. As long as economic aims are considered the only accepted public aims, with

priority over social objectives and values, the destruction of ecological integrity or the lack of sustainable development are, at worst, not even recognized by society. At best, they are considered necessary environmental externalities.

### 3. Geographical patterns in the current occupation of the Andes

The regional distribution of key variables for economic, social and environmental development in Chile is shown in figure 1. Figure (1a) shows that the northernmost (Atacama Desert, I and II) and southernmost (Patagonian, XI and XII) Chilean regions, are the largest regions in terms of land surface. However, considering that the former are arid lands and the latter cold landscapes, the population in both zones is fairly small, reaching densities below 1 inhabitant per square km.

In Central Chile, with mediterranean climate types and a concentration of agriculture and industry, live near 80% of the Chilean population (Fig. 1c). It means that mineral northern regions and wildlife southern regions are largely uninhabited. Chile is a very centralized country with near 40% of its total population living in

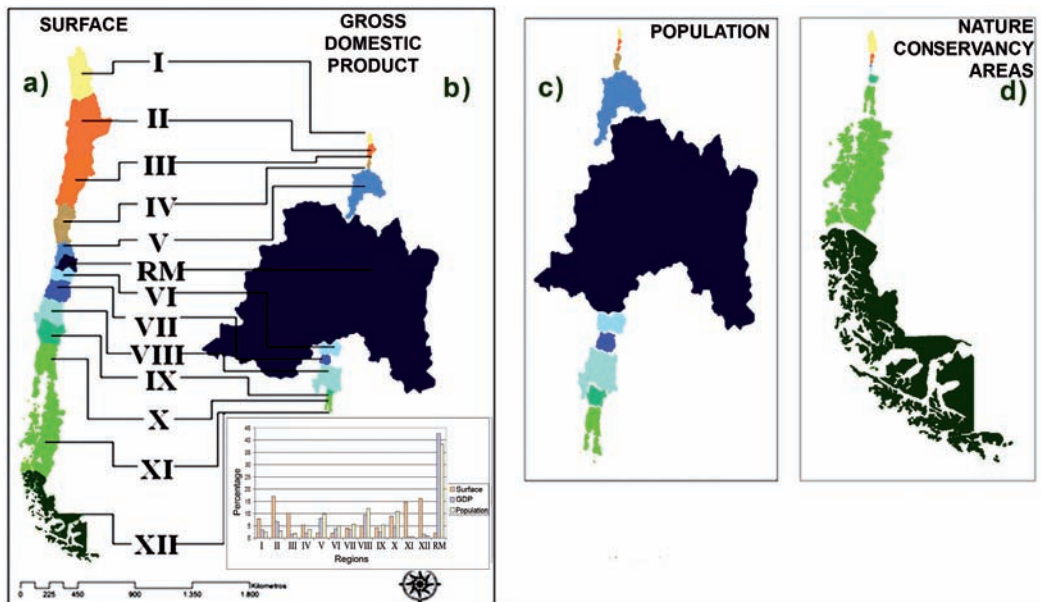

Fig. 1: Comparison between surface area and the distribution of economic, demographic and nature conservation areas in Chile. Source: Authors' own calculations.

its capital Santiago. While in Central Chile population, services and goods are available without restriction in the lowlands; social development is clearly constrained in marginal geographical regions, especially in Andean mountain areas.

The distribution of nature conservation areas (Fig.1d) forms a completely different pattern from that of socio-economic centres. In northern regions, national parks and natural reserves are concentrated in the highlands, while in the southern regions (Fig. 1d). they can be found anywhere. In Patagonia, nearly 95% of the land is in public ownership and 50 % of Aysen regional surface is occupied by the public system of wild protected areas.

The geographical representation of domestic economic product and population differs greatly from the spatial concentration of nature conservation zones. Socio-economic geographical patterns are becoming very unequal in Andean countries. Inequalities are even more marked between large metropolitan and modern urban areas and the location of economic enclaves and marginal and traditional mountain areas (Fig.1b). Public policies and private investments, even if they are significant in some mountain enclaves, are not able to produce a more even distribution of sustainable development factors and elements.

Mountain areas with extreme orographic complexity severely reduce accessibility, transforming physical distances into rather higher cost distance and time distance. Increasing costs seriously diminish comparative opportunities for socio-economic development in such mountain regions. Compensating these territorial inequalities requires particular public policies to mitigate the impacts of mountains barriers and conflicts. However, the liberal and global economic concepts applied everywhere in Chile disregard these geographical differences, which in turn explains lower levels of development in Andean areas, such as Chilean southern Patagonia. Figure 2a shows physical distances between the main Chilean cities, and

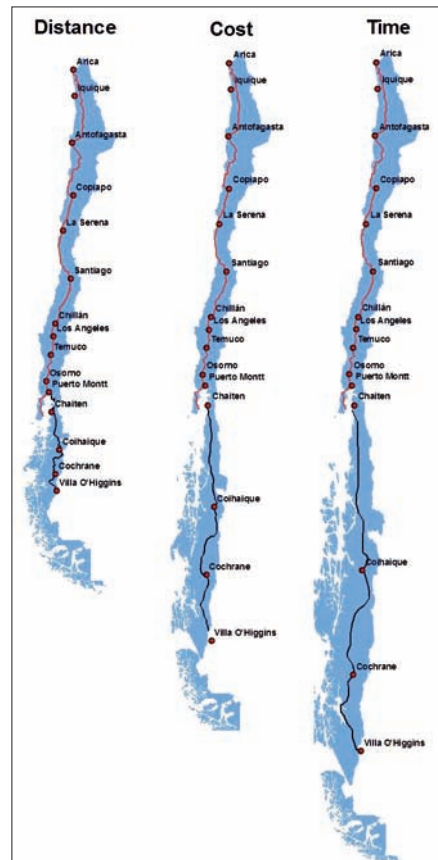

Fig. 2: Absolute and relative distances (in km.) in Chile. Source: Authors' own calculations.

figure 2b, the equivalent of physical distances in terms of economic costs. Figure 2c shows the time that is required to move within and outside the region.

Figure 3 shows the distribution of mining and related investment projects in the Atacama desert and its surrounding areas, including Andean highlands and semi-arid regions located further south. Economic investments form complex clusters and corridors that severely impact on whole landscapes. Apart from mining that forms dotted interventions and are mainly located in inland areas of intermediate height, gas pipes and roads are creeping up and crossing Andean peaks. Some of the new large mining projects like Pascua Lama have sites at both the Chilean and Argentinean slopes of the Andes, creating a sort of new frontier between the two countries.

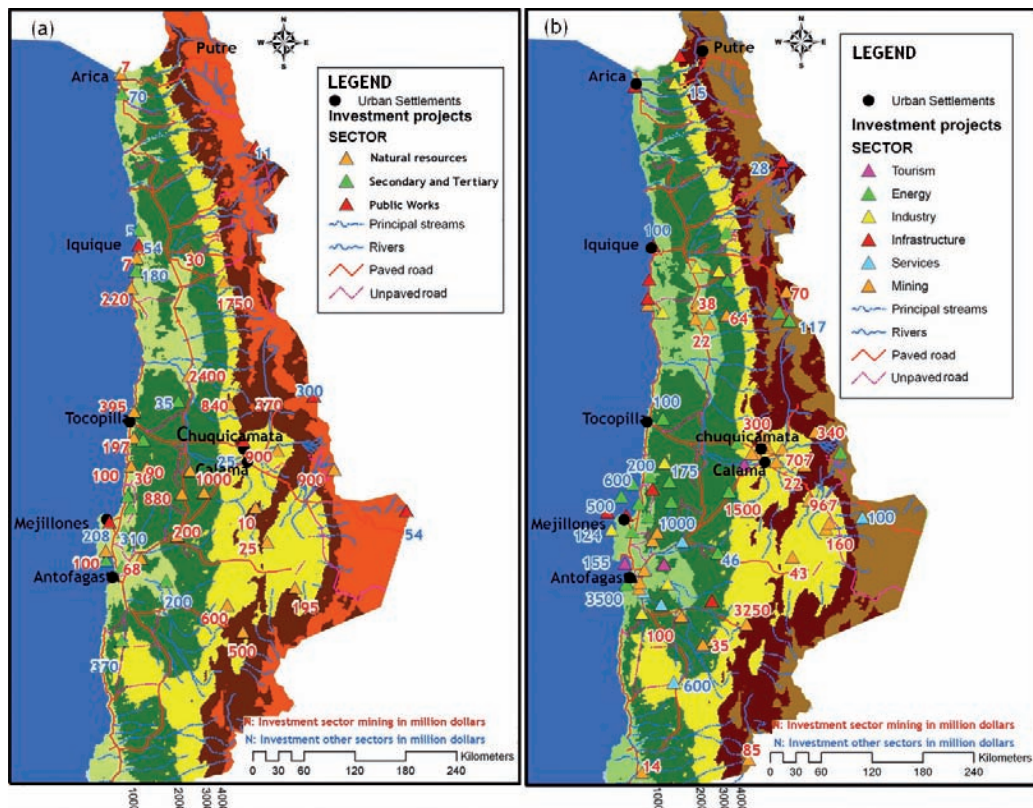

Fig. 3: mining and related investment projects in the Atacama desert and its surrounding areas. (a) 1990 – 2000 and (b) 2006 – 2008. Source: Authors' own calculations.

Figure 3a shows investment projects implemented between 1990 and 2000 in and around the Atacama desert. Mining is connected with power plants and harbours installations to import industrial necessities and export raw materials. They are also connected with cities, where the labour force lives and where they obtain local goods and services. All the necessary water must be captured at Andean highlands lagoons, salty lakes and rivers. Given the extraordinarily arid conditions of the Atacama desert, most of the thin rivers and streams disappear down water by evaporation, where they cross the core of the arid lands.

Water sources are located at the highlands, where native people live and where nature conservation areas have been declared, as can be seen in figure 3a. There is an increasing and unresolved conflict between local communities, conservation authorities, and mining companies, about the ownership and management of water sources. Local communities formed by native farmers are trying to enforce their ancestral rights to use and control the highlands as their historical heritage, against the government and private companies' interests. Conservation authorities are always confronted by pressure from local communities and by public and private mining companies to decertify large areas currently under the protection of the State. National and international mining companies are increasingly interested in using as much as possible superficial and ground water which is needed for their production processes.

Chile is the main producer of copper and associated minerals in the world and the demand is continuously increasing, especially as a result of recent Chinese industrialization. Copper has reached its highest historical price in recent years and this has triggered many new investments. Figure 3b presents an update of mining projects that have been or will be implemented in 2008. 60% of the total national mining investment is in the Atacama desert. In year 2000 it was already evident that available water in some of the most important Andean watersheds was completely allocated. To secure the supply of these resources water was reallocated to the different economic activities (mining, agriculture, and drinking water companies), facilitating the function of water markets, reassigning water used by farmers and native people, and extracting water from lakes and ground sources. Water was even imported from neighbouring Bolivia.

In the year 2000 the first cluster of mining and related installations was located at Iquique latitude (20°S) and was clearly spatially organized by Doña Ines de Collahuasi, a large copper mine that also produces molybdenum, located at more than 3000m altitude in the Andes. Main spatial interaction related to harbour facilities,

services and housing for the work force, situated in the nearby towns of Iquique and Patache, and energy plants located in the latter place. Doña Inés de Collahuasi is one of the most productive and successful companies operating in the Atacama desert. It belongs to companies linked to Anglo American (USA, 44%), Xstrata (Switzerland, 44%) and Mitsui (Japan, 12%). This company extracted 19,1 m<sup>3</sup> of water in 2003 and has increased that figure to 29,1 m<sup>3</sup> in 2005. Its rate of consumption was 0,66 m<sup>3</sup> per ton of concentrated mineral in 2005, which is obtained from the nearest salt lakes ground water. The growth of the installations and production depends in large measure on a proposed uptake of ca. 1000 l/sec of water from wells located in Huasco Salar, the largest salt lake in the region.

The second cluster was located at Antofagasta latitude (23°S) and was mainly organized by a spatial corridor from Escondida Mining to the sites of CODELCO (the Chilean State Company) near and above Salar de Atacama, at between 2000 and 3000m altitude. In the year 2000 this mining cluster and corridor was the most important in the country and included a vigorous development of the coastal border due to the establishment of thermoelectric energy plants, harbour facilities and urban services.

La Escondida is the largest copper producer at world scale. In 2006 it produced 1,256,000 metric tons or 8,1% of the total world production. 57,5% of this company is owned by Australian BHP Billington, 30% by Rio Tinto (U.K.) and 10% by the Japanese Jeco Co. Japan (Mitsubuchi Corporation and Nippon Company of Mining and Metals). In 2006 its water consumption was 0.80 m<sup>3</sup> per ton of sulphured copper and in 2007 0.69m<sup>3</sup>/ton.

Water used by La Escondida is obtained from deep wells located in salt lakes and watersheds in the upper Andes. 1,318 l/sec is extracted from Salar de Monturaqui, located at 3,200m. It is estimated that 196,901,804 m<sup>3</sup> of water has been extracted from this ecosystem since the plant started operation. Other mountain sources of water are deep wells located at Salar de Punta Negra, and proposed extractions in Pampa Colorada watershed, all of them situated in the Andes highlands, in the zone called Puna de Atacama, where most of the rivers and streams have their origin (Fig.3a).

The extraction of ground water in salt lakes and other water bodies located at the higher Andes lands is an increasing matter of concern for Chilean society that is expecting scientific inputs than can sustain the right decisions. Andean water sources are the recharge areas of aquifers that support rivers and streams, which finally emerge in the lowlands, where agriculture and urbanization take place. Romero and

Kampf (2003) have demonstrated that ground water tables are sinking in the central and coastal areas of the Atacama desert.

Figure 3b shows the distribution of mining in 2007 in the northernmost section of the Atacama desert. The main cluster of mining projects is in and around Salar de Atacama, the largest salt lake in the region, where a series of highland rivers and streams converge. But on the whole there is a migration of the larger mining investments further south, towards semi-arid regions (figures 4a and b). Water scarcity in the North and the discovery of new mineral reserves further south contribute to this trend.

In the semi-arid Chilean regions (figures 4) that extend from 27 to 32°S Chile has its narrowest section. The distance between the mountain peaks and the coast is less than 120km. Several Andean rivers reach the coast here and have created fertile agricultural valleys in the Norte Chico (“Small North”) or region of transversal valleys.

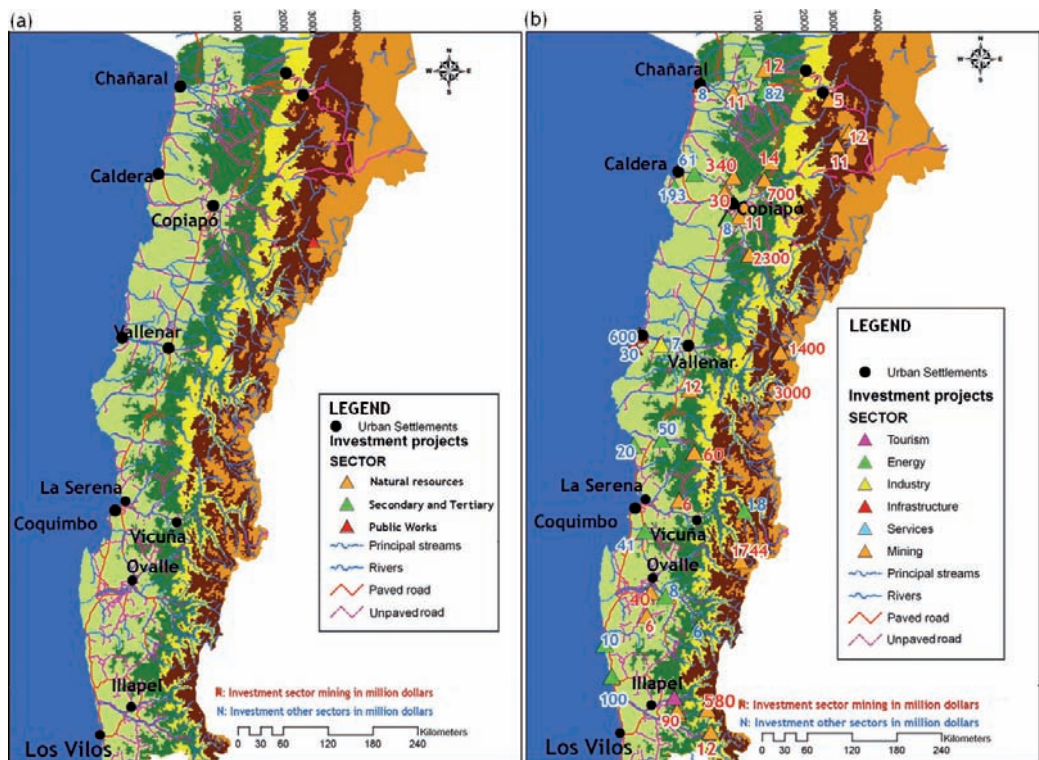

Figures 4: mining and related investment projects in semi-arid regions. (a) 1990 – 2000 and (b) 2006 – 2008. Source: Authors' own calculations.

Copiapó river (Figure 4a) is one of the Andean semiarid valleys that has supported modern agricultural development in recent decades. Earlier this valley was mainly involved in small-scale mineral production, but has recently shifted to producing table grapes and other fresh fruit for export to North American, European and Asian markets. To sustain this agricultural production, the irrigation infrastructure must capture water in the highlands and transport it along canals. In the Copiapo valley, annual rainfall is around 10mm and climate change promises a reduction. In the map, which represents the situation in the year 2000, a projected gold mine was the only relevant investment located in the highlands.

The southern valleys Huasco, Elqui, Limarí and Choapa have also strongly specialized in the production and export of fresh fruit, taking advantage of permanently clear skies and more abundant water coming down from Andean highlands. In the Huasco valley annual rainfall is around 50mm, in Choapa around 200mm. In intermediate and lower mountains, rain-fed traditional farming communities have sustained local settlements since colonial times. These communities still practice livestock (especially goats) transhumance, using grasslands in the Andes highlands during summer and at the coastal lowlands in the winter season.

However, as observed in year 2007 (Fig. 4b), several mining installations have been or are going to be located in upper and intermediate lands. Cerro Casals, with an investment of 2,300 million dollars, is the largest project in Copiapó valley and leads to a dispute with modern farmers and the urban population, because they are extracting water in the uplands that had been used for rural and urban purposes before. The Copiapó river has been completely dry in recent years.

Cerro Casals is an open copper and gold mine that belongs to Star Arizona. This company owns 51% of Arizona Star, 49% belongs to the Kinross Gold Corporation, both Canadian companies. Currently they are exploring and getting water extraction licences to withdraw 1,237 l/sec from 17 deep wells located in Piedra Pómez, an aquifer in the highlands, 121km upwards of the mine. Another water source is Pedernales, situated in the highlands, 210km north of the mine.

The environment of the Copiapó valley is threatened by the establishment of numerous other mining projects that compete with several other economic and social activities for the use of water. One of the other largest mineral investments was made by Caserones Pan Pacific Copper (700 million US dollars), owned by the Japanese company Lumina Copper (Fig. 4b). This large open mine is located at 4,600m a.s.l. and its expected production will be around 160-220 tons per day. When they have extracted 6,000 million tons of mineral, the open mine would have reached a depth of 610m, a length of 1.7km and a width of 1.6km.



Another very relevant and typical water conflict has arisen between traditional farmers, highlands local communities and the Canadian company Barrick Gold, which is trying to establish the largest project (more than 3,000 million US dollars) called Pascua Lama. This company has attempted to relocate Andean highland glaciers to a place far away from its proposed ore to facilitate its installation. This action was strongly resisted by Chilean society, and the Canadian company eventually decided to postpone this project. They offered a lot of money to modern farmers in the lowlands as compensation for extracting the required water from the river, but they did not reach an agreement with poorer rural communities living at medium and higher lands and depending much more on livestock. Apart from this unresolved water conflict, the situation has become more complicated because recently new mining projects like El Morro, owned by the Swiss Xstrata company, are also planning to extract water from the upper Huasco watershed. According to existing information there is a series of proposed mining projects to be built at highlands that were previously only used as grasslands, water reservoirs and nature conservation areas.

Pascua Lama is an open gold, silver and copper mine, situated above 4000m altitude at Andes highlands shared by Argentina and Chile. This location has required a special international agreement between both countries to facilitate the transport of industrial inputs, outputs and labour. This agreement creates a de facto international free territory and has been postponed several times because of difficulties with setting up custom and tax systems. Argentina and Chile want to receive as much money as possible from this investment.

The time frame for this project of mineral exploitation is up to 23 years and the estimated reserves are 18 million ounces of gold and 731 million ounces of silver as well as 662 million pounds of copper. Water requirements are 370 l/sec provided by the Andean Argentinean river Las Taguas, and 42 l/sec from the Chilean Estrecho river, a highland tributary of the Huasco river. Main concerns are not only water uptake but also water pollution that could affect irrigation schemes.

In the same valley Swiss company Xstrata Coppers is setting up El Morro. Falcombridge holds 70% of the company and Metallica Resources Limited 30%. The estimated life-cycle of this project is 16 years and the mineral resources are estimated at 489 million tons of copper containing 0.52 gold grams per ton.

Similar large mining investments are currently taking place along the Choapa river, a traditional agricultural and small mining valley that is situated in the southernmost part of the Chilean semi-arid region, near the Mediterranean climate type of the Central Chile landscapes. Around 200mm of annual rainfall have supported a

substantial rainfed and irrigated agricultural development for many centuries.

In Choapa Valley, Los Pelambres, 40% of the largest mining project is owned by Chilean capital (Luksic family) and 60% by Japanese investors. Estimated reserves of copper reach 4,000 million tons of ore and are situated in the Andean highlands, near the Chilean border with Argentina. The most impressive investments in connection with this project are the construction of two large dams to contain mineral wastes. These dams are going to flood 4,000 ha of land and will be connected by a canal of 15km length. Another canal will transport the mineral from the neighbouring Salamanca valley.

Table 1 presents a synthesis of the most important existing or proposed mining investments in the Atacama desert and its surroundings. It is clear that the environmental sustainability of the Northern Chile Andes highlands is increasingly at risk.

Figure 5 presents the complex geographical and environmental structure of Chilean Patagonia and the present situation in terms of natural environments, land uses and spatial organization.

## Global Changes and Economic Globalization in the Andes

*Table 1: Synthesis of the most important existing or proposed mining investments in the Atacama desert and its surroundings. Source: Authors' own calculations based on SOFOEA.*

COMPANY - PROJECT	Status	Total Investment	Investment Balance	Country
Compañía Minera Nevada (Barrick Gold Corp.): Proyecto Pascua Lama	Pending	3000	1500	Canada
Minera Estrella de Oro (Arizona Star Resources - Kinross): Proyecto Minero Cerro Casale	Pending	2300	2300	Canada
Minera Esperanza (Antofagasta Minerals): Proyecto Esperanza	Pending	1500	1500	Chile
Minera Falconbridge (Xstrata Coppers): Proyecto El Morro	Potential	1400	1400	Switzerland (70%) Canada (30%)
Codelco (División Codelco Norte): Minera Gabriela Mistral (ex Gaby)	In Progress	967	36	Chile - State
Codelco (División Codelco Norte): Chuquicamata Subterránea	Potential	707	707	Chile - State
Pan Pacific Copper: Proyecto Caserones (ex Regalito)	Potential	700	700	Japan
Minera Los Pelambres (Antofagasta Minerals): Proyecto Tranque de Relaves El Mauro	In Progress	580	19	Chile
Minera Carmen de Andacollo: Proyecto Hipógeno (Andacollo Sulfuros)	Pending	350	350	Canada (70%) Chile (30%)
Codelco (División Codelco Norte): Expansión Mina Ale Alejandro Hales (ex Mansa Mina)	Potential	340	340	Chile - State
Compañía Minera del Pacífico: Hierro Atacama, Fase II - Cerro Negro Norte	Pending	340	340	Chile
Minera Falconbridge (Xstrata Coppers): Extension Lomas Bayas	In Progress	335	168	Switzerland
Antofagasta Minerals: Proyecto Antucoya	Potential	300	300	Chile
Codelco (División Codelco Norte): Extracción y Movimiento de Minerales Mina Radomiro Tomic	Pending	300	300	Chile - State
SQM Salar: Cambios y Mejoras de la Operación Minera en el Salar de Atacama	In Progress	234	176	Chile
Codelco (División Codelco Norte): Minera Gabriela Mistral (II Fase)	Potential	160	160	Chile - State
Atacama Minerals Chile: Ampliación Aguas Blancas	In Progress	100	67	Chile



First of all, Chilean Patagonia is the most Andean Chilean region, and mountains dominate everywhere. In the eastern section the mountainous landscape is broken up by numerous lakes and narrow river valleys, the western archipelagic part contains fjords and sea canals.

The spatial organization is controlled by large watersheds: Cisne valley in the North, Simpson in the Centre, General Carrera lake and Baker river in the South, and Pascua river in the extreme South, link the mountain chains with the sea coast. The Northern and Southern ice fields drain glaciers and waters towards the continental eastern side and towards the maritime western coast. In the Aysén region all the landscape features are strongly interconnected and the environmental and ecological integration explains the presence of the cleanest air, water and soils, plus an extraordinary biodiversity.

Taking into account this high environmental complexity, diversity and quality, most of the region is public land and 50% of its territory is made up of nature conservation areas. These public protected areas form a continuum in the western section, from Las Guiatecas Nature Reserve and Magdalena Island National Park in the North to Laguna San Rafael National Park in the Centre and Katalalixat Nature Reserve and Bernardo O'Higgins National Park in the South.

On the eastern side there are important nature conservation areas, but this region is also used extensively for animal husbandry and forestry. Important ecological transects and corridors can be found in the northern section, including Queulay National Park, and at the Centre, in Río Simpson National Park and in the Cerro Castillo and Jeinimeni Natural Reserves.

To ensure connectivity between conservation areas and to protect some biodiversity hotspots, environmental authorities have introduced Biodiversity High Priority Sites, e.g. Islas Guamblin in the North; Anna Pink-Estero Walker, Islas Kent and Sector Hudson in the Centre and Baker and Pascua watersheds, O'Higgins Lake and Canal Messier in the South. Although these priority sites are not equivalent to protected areas that belong to the National System of Wild Protected Areas, they constitute necessary land to link up the whole system designed to promote the conservation of many pristine zones.

Human settlements are isolated and self-sufficient places and situated along rivers and around Lake General Carrera, the binational (Argentinean-Chilean) and largest Chilean lake. All the land that surrounds this lake has been declared a tourist zone in an effort to protect nature and cultural goods and services. Given the topography and climate, roads and human settlements can only occupy very specific places. As

a consequence, Aysen has only a small population; around 100,000 inhabitants live in a territory of approximately 100,000 km<sup>2</sup>. Most of the region is unpopulated and many nature reserve areas are inaccessibly by road.

Ice fields are especially relevant to supply abundant and permanently high discharges to Baker and Pascua rivers. These rivers, together with many others, constitute the principal Chilean hydropower reserve. For decades this region was not considered for hydropower generation. Nature conservation priorities, difficult access and the distance to the areas of major demand (industrial urban centres in Central Chile are located in a distance of 2.000 km, and the Northern mines are located in a distance of 3.000 and 4.000 km) were strong arguments against building any hydroelectric power stations.

Over the last ten years Chile has doubled its domestic product and its energy consumption has increased threefold. The country must import all the oil that it needs and the Argentinean natural gas import has been completely reduced. As long as public authorities show no real interest in developing alternative sources of energy, the national society is forced, without any real and serious debate, to accept the establishment of foreign-owned installations in Chilean Patagonia to produce some of the energy that is needed.

Table 2 shows the amount of money that will be invested by national and foreign companies in the construction of the first five hydropower dams and the respective transmission line. However, there is a long list of new projects which are expecting the construction of the transmission line to be installed in several large rivers.

*Table 2: Amount of money that will be invested by national and foreign companies in the construction of the first five hydropower dams and the respective transmission line. Source: Authors' own calculations based on HidroAysén.*

<b>COMPANY - PROJECT</b>	<b>Status</b>	<b>Total Investment</b> (in million US dollars)
Transelec: New electricity transmission lines between Aysen and Santiago (Project HidroAysén)	Potential	1.600
HidroAysén (Endesa Chile-Colbún): Hydroelectric Project Aysén (Pascua 2.1)	Potential	820
HidroAysén (Endesa Chile-Colbún): Hydroelectric Project Aysén (Baker 1)	Potential	710
HidroAysén (Endesa Chile-Colbún): Hydroelectric Project Aysén (Pascua 2.2)	Potential	550
HidroAysén (Endesa Chile-Colbún): Hydroelectric Project Aysén (Pascua 1)	Potential	510
HidroAysén (Endesa Chile-Colbún): Hydroelectric Project Aysén (Baker 2)	Potential	410

As in the case of mining in Northern Chile, energy production seems able to change the environmental conditions of Chilean Patagonia abruptly and definitively. In the current debate only economic priorities seem to count. Again, environmental and ecological values are completely subordinated to decisions that are going to be made by national central services in coalition with foreign transnational companies.

The following tables illustrate the current situation in what can only be interpreted as a general abandonment of public responsibilities for nature protection. The first table (Table 3) demonstrates the capacity for managing the environment of the five municipalities in the area. Municipalities are the main local government institutions in the country. Seven out of nine do not have any person, office or unity in charge of environmental issues. Only one of nine municipal governments has set up an environmental agenda or environmental management plan and uses some financial resources for the protection of the environment. Only two of them have introduced some local legal instruments to control environmental issues in their territories. The only municipality that has some complete environmental management institutions is Coyhaique, the main city and regional administrative capital.

Table 3: Environmental management capacity of Southern Aysen municipalities. Sources: CONAMA-CAS, 2007. *Encuesta sobre Capacidades Municipales en Gestión y Planificación Ambiental.*

Municipality	Environmental management office, unit or person	Environmental strategy, plan or agenda	Environmental management financial resources	Environmental management Municipal legal instruments
<i>Provincia de Capitán Prat</i>				
▪ Cochrane	No	No	No	No
▪ Tortel	No	In preparation	No	No
▪ O'Higgins	No	No	--	No
<i>Provincia de General Carrera</i>				
▪ Chile Chico	Yes	No	No	No
▪ Río Ibáñez	No	No	No	No
<i>Provincia de Aysén</i>				
▪ Aysén	Yes	In preparation	Yes	Yes
▪ Cisnes	No	No	Yes	No
▪ Guaitecas	No	No	No	No
<i>Provincia de Coyhaique</i>				
▪ Coyhaique	Yes	Yes	Yes	Yes
▪ Lago Verde	No	No	No	No

However, the lack of local governance is not the only deficiency that confronts the environmental protection and management at Chilean Patagonia. Table 4 illustrates the institutional capacity of the national public services to plan, manage and control regional protected areas and natural resources. The service in charge of wildlife protection has more professionals and technicians because it is also responsible for animal health. However this public service does not have the financial and information resources to play its important role. In the National Forestry Commission – which in Chile is the public service in charge of protected areas – most employees are devoted to control summer forest fires but not to protect national parks or nature reserves. In fact there are no park rangers in regional protected areas and nor do they seem to have any financial or technical information to play their fundamental role in this area.

Money that is available for promoting tourism in the region is there because of a one-off international loan ring-fenced for this purpose. However, the tourist service does not provide any information or technical resources. The lack of professionals, information and techniques and of financial resources is typical for the situation of environmental management in the Chilean public services. Under these institutional conditions it is very clear that environmental protection and control are not a public priority.



Table 4: Capacity of public national institutions to protect and manage protected areas and natural resources in the Aysén region. Source: Based on field interviews.

Institution	Competences	Professionals and technicians	Financial resources (in '000 US dollars)	Information and technology	Location
Servicio Agrícola y Ganadero (wildlife protection)	Natural resources and wildlife protection	23 professionals and 25 technicians	No data	No	Coyhaique, Puerto Aysén, Chile Chico and Cochrane
Corporación Nacional Forestal (National Forestry Commission)	Protection of conservation areas	18 park rangers and 147 workers	No data	No data	4 national parks and 12 nature reserves and national monuments No park rangers in the region Offices at Coyhaique, Puerto Aysén, Chile Chico, Cochrane, Puerto Tranquilo, La Junta, Tortel, Villa O'Higgins
Servicio Nacional de Turismo (National Tourism Service)	Tourism development and promotion	8 workers	700	No	Offices in Coyhaique and in the municipalities
Gobernación Marítima (maritime authority)	Marine environmental protection	No data	No	No	Capitanías de Puerto en Melinka, Puerto Cisnes, Chacabuco, Chile Chico, Caleta Tortel & Puerto Aguirre
Servicio Nacional de Pesca (National Fishing Service)	Fishing and marine environmental protection	30 workers	No data	No	Puerto Aysén & Melinka
Dirección General de Agua (National Water Authority)	Water quantity and environmental quality control	8 professionals	No data	No	Coyhaique
Ministerio de Bienes Nacionales (Ministry of National Assets)	Fiscal properties inventory and administration	21	100	No	Coyhaique

*References*

- Borsdorf, A. 1987. Grenzen und Möglichkeiten der räumlichen Entwicklung in Westpatagonien am Beispiel der Region Aisén. Natürliches Potential, Entwicklungshemmnisse und Regionalplanungsstrategien in einem lateinamerikanischen Peripherieraum. Acta Humboldtiana 11, Stuttgart.
- Ibañez G, C y Pizarro, R. 2003. El cobre y su inserción en el mundo: cómo cobrar el sueldo de Chile. rpp14. Terram Publicaciones, Santiago, Chile.
- Instituto Geográfico Militar (IGM). 1983. Fundamentos geográficos del territorio nacional. Tomo I Geografía de Chile. Editor, Instituto Geográfico Militar (IGM), 1ª. Ed, Santiago, Chile.
- Romero, H. and Kampf, S. 2003, Impacts of climatic fluctuations and climate changes on the sustainable development of the arid Norte Grande in Chile. In: Diaz, H. F. and Morehouse, B. J. (eds.), Climate and Water, Transboundary Challenges in the Americas, Kluwer Academic Publishers, Dordrecht, The Netherlands: 83-116.
- Romero A, H. 1983. Geografía de los climas. Tomo XI Geografía de Chile. Editor, Instituto Geográfico Militar (IGM), 1ª. Ed, Santiago, Chile.
- Sociedad de Fomento Fabril (SOFOFA). 2007. Catastro de Proyectos de Inversión. Departamento de Estudios.

# Land Use Change in the Northern Carpathians

Jacek Kozak

Institute of Geography and Spatial Management, Jagiellonian University, Krakow, Poland

The Carpathians are middle mountains that stretch across the Czech Republic, Poland, Slovakia, Hungary, Ukraine and Romania in the heart of the Central Europe. Forests are the wealth and a major resource of the region, a habitat of many species, including large mammals. For the whole Carpathian region (including Transylvania), forests cover approximately 50% of the area and up to 80-90% between 1000-1500 m a.s.l. Alpine areas above the timberline are isolated, especially in the northern part of the mountains, and comprise only 2% of the region.

In the 19<sup>th</sup> century most of the mountains belonged to the Austrian Empire. After the World War I the region was divided among several independent states which later experienced the turmoil of the World War II. Its consequences were substantial shifts of political boundaries and almost 50 years of communism.

Until 1945 development trajectories were relatively similar across all the area: colonization of the mountain area, development of small-scale agriculture and grazing, exploitation of forests and mineral resources. In 1945 the continuity was broken in the eastern part of the Carpathians due to re-settlement actions. Between 1945-1990 several new factors of land use change appeared, like rapid industrialization, collectivisation or mass tourism. After 1990 a socialist, centrally-controlled economy was transformed to the market-oriented one, with tremendous consequences for land use and mountain landscapes. Two processes currently dominate in the region: forest expansion and urban sprawl (Fig. 1), both benefiting from a gradual decline of mountain agriculture, and hence a supply of land and labor.

In the northern Carpathians in Poland a slow decline of mountain agriculture has started since the peak of agricultural expansion around the middle of the 19<sup>th</sup> century (Kozak 2003). Throughout the 20<sup>th</sup> century the decline of agriculture resulted in a steady increase of forest cover – forest transition in the sense proposed by Mather (1992) – strengthened in some regions by re-settlement actions and depopulation processes (Kozak et al. 2007). Especially in the sub-alpine and alpine areas depressed anthropogenic timberlines were gradually expanding up. This expansion has led to the removal of many mountain pastures and re-establishment of spruce communities in the formerly deforested areas (Sitko & Troll, 2008).



*Fig. 1: Afforestation, Beskidy Mts., hotels in construction, Pieniny Mts., photographs by the author*

Forest cover change rates in the 20<sup>th</sup> century varied from 0.2% to more than 2% annually (Kozak, in press), the highest values recorded in the depopulated areas. Conversion of agricultural, open land into forests has speeded up in the Carpathians after 1989, when the transformation of economies in former communist countries triggered a significant abandonment of agricultural land, and forest succession (Kuemmerle et al. 2008). However, the contribution of the recent agricultural land abandonment to future forest cover is still a matter of question due to the variability of driving forces affecting agriculture.

The last 20 years have witnessed also a rapid urban sprawl in many locations in the mountains. Estimates on a basis of aerial imagery show a twofold increase in the built-up area in the Polish Beskidy Mts. between 1950s and 1990s (Woś 2005). Urban sprawl in the Polish Carpathians is fuelled additionally by a rapid development of tourist infrastructure (e.g. skiing areas; fig. 2) and second homes. For example, in the Silesian Beskid Mts. the number of second homes increased five times between 1980 and 2001 (Mika 2004).



*Fig. 2. New skiing areas in the Polish Carpathians, photographs by the author*

Both major forms of land use change in the northern Carpathians – forest expansion and urban sprawl – significantly modify or even erase the former cultural landscapes of the region, dominated once by agricultural activities (Angelstam et al. 2003). Both are controlled and driven by complex interactions within the socio-economic system, at different levels of spatial hierarchy, leading to present-day variation of land use change trajectories. Political boundaries, important in the region since the early 20<sup>th</sup> century have practically disappeared, hence an increasing dynamics of land use change may be expected.

### *References*

- Angelstam P., Boresjö-Bronge L., Mikusiński G., Sporrang U., Wästfelt A., 2003, Assessing Village Authenticity with Satellite Images: A Method to Identify Intact Cultural Landscapes in Europe. *Ambio*, 32, 594-604
- Kozak J., 2003, Forest Cover Change in the Western Carpathians in the Past 180 Years. A Case Study in the Orawa Region in Poland. *Mountain Research and Development*, 23, 369-375
- Kozak J., Estreguil C., Troll M., 2007, Forest cover changes in the northern Carpathians in the 20<sup>th</sup> century: a slow transition. *Journal of Land Use Science*, 2, 127-146
- Kozak J., Forest cover changes in the Polish Carpathian Mts. since 1800. In: H. Nagendra, and J. Southworth (eds.), *Reforestation landscapes: linking pattern and process*, in press
- Kuemmerle, T., Hostert, P., Radeloff, V.C., van der Linden, S., Perzanowski, K, and Kruhlov, I., 2008, Cross-border Comparison of Post-socialist Farmland Abandonment in the Carpathians. *Ecosystems* 11, 614-628

## Global Change and Sustainable Development in Mountain Regions

Mather A.S., 1992, The forest transition. *Area*, 24, 367-379

Mika M., 2004, Turystyka a przemiany środowiska przyrodniczego Beskidu Śląskiego [*Tourism and the environmental changes in the Silesian Beskid Mts.*], Instytut Geografii i Gospodarki Przestrzennej Uniwersytetu Jagiellońskiego, Kraków

Sitko I., Troll M., 2008, Timberline Changes in Relation to Summer Farming in the Western Chornohora (Ukrainian Carpathians). *Mountain Research and Development*, 28, 263-271

Woś B., 2005, Zmiany pokrycia terenu w wybranych gminach Beskidów w drugiej połowie XX w. na podstawie analizy zdjęć lotniczych. *Teledetekcja środowiska* 35, 1-114

# The Past and Future of Rocky Mountain Forests: Connecting People and Ecology

Dan Binkley

Colorado Forest Restoration Institute, Warner College of Natural Resources, Colorado State University, Ft. Collins, CO USA 80523

## *The Forests*

The Rocky Mountains form the backbone of the North American continent, separating waters flowing eastward to the Atlantic and westward to the Pacific. The mountain range reaches from northern New Mexico in the south to Alberta and British Columbia in the north, with elevations ranging from 1500 to 4300 m. The forests found in this extensive segment of the continent vary substantially, from semi-arid woodlands of juniper and pinyon pine at lower elevations to the south, to boreal spruce and alpine ecosystems at high elevation and to the north (Peet 2000).

Colorado sits near the southern end of the Rocky Mountains. The major issues that will shape the future of Rocky Mountain forests are shared across the range, so the situations in Colorado can be expanded to a larger scale.

The six major forest types were shaped to varying extents by the frequency and severity of fire (Fig. 1). Lower elevation forests are frequently dry enough to burn, and lightning storms are common. However, the continuity of fuels in the driest pinyon-juniper woodlands does not support the frequent, extensive fires carried by the well-developed grass and shrub understories in the ponderosa pine forests. Higher forests are generally too humid to burn, except during once-a-century droughts. The highest elevation forests burn at intervals of several centuries, if at all. Other disturbance factors have been important in these forests, including bark beetle outbreaks and severe windstorms (especially at higher elevations) (Veblen et al. 1994).

Colorado has 8.6 million ha of forests with public lands comprising about two-thirds of the forested area. Over 200,000 private land owners control 3.5 million ha; the proportion of private forest land is much greater at lower elevations. At the level of the entire state, the forests are changing rapidly. The standing growing stock of wood has increased by more than 40% over the past 50 years, to the current level of 500 million m<sup>3</sup>. The rate of forest harvest fell by more than 80% in the 1990s,

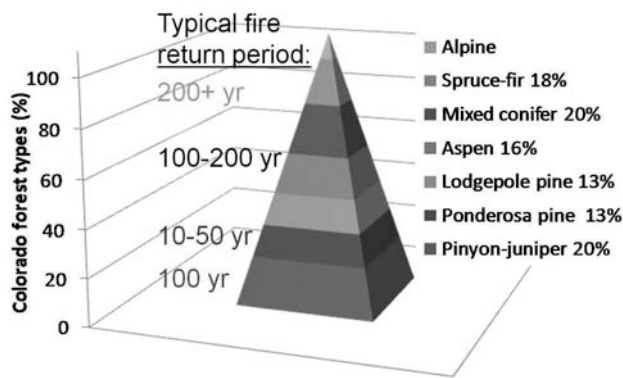

*Fig. 1: The forests of Colorado are composed of similar proportions of six major types. The historical fire regimes in low-elevations forests of pinyon pine and juniper were limited by low accumulations of fuels, and fires occurred at a time scale of a century (or longer). The productivity of ponderosa pine forests was higher, and abundant growth of understory plants supported fires every 10 to 50 years, either mild surface fires or more intense, mixed severity. Forests of lodgepole pine, aspen, and mixed conifers experienced fires on a time scale of one to two centuries, typically during periods of severe drought. The highest forests of Engelmann spruce and subalpine fir burned at intervals of 2 centuries or longer.*

in part as environmental issues took precedence over timber harvesting goals for public lands. The forestry industry infrastructure contracted substantially, with only one major mill still operating in Colorado. Current harvests now represent less than 5% of annual growth.

This dramatic increase in wood content of Colorado forests also represents a major increase in potential fuels for wildfires, particularly at lower and mid elevations. The cessation of periodic fires allowed the density of some ponderosa pine forests to increase very dramatically (Colorado Forest Restoration Institute; [http://www.cfri.colostate.edu/docs/cfri\\_ponderosa.pdf](http://www.cfri.colostate.edu/docs/cfri_ponderosa.pdf))(Fig. 2). Fire regimes have been less altered from historic patterns at higher elevations, but the low rates of forest harvest combined with natural stand development led to extensive landscapes occupied by old forests. For example, more than half of the lodgepole pine forests are over a century old, and only 7% of the forests are under 60 years old. The susceptibility of forests to insects and diseases often increases with stand age, and Colorado is experiencing a massive mountain pine beetle outbreak with more than 80% mortality of old trees across entire landscapes (more than 400,000 ha statewide). Warm and dry weather may also have fostered the population explosion of mountain pine beetles (Colorado Forest Restoration Institute; [http://www.cfri.colostate.edu/docs/cfri\\_insect.pdf](http://www.cfri.colostate.edu/docs/cfri_insect.pdf)).

In the 1990s, foresters were concerned that normal stand development was increasing the proportion of conifer forests in Colorado at the expense of aspen (Shepperd et al. 2001). A sudden, widespread death of old aspen trees broadened concerns about the current condition and future of aspen forests. In the past 5 years, the majority of old aspen trees died across 130,000 ha. Younger aspen trees were less affected, and aspen regeneration may be high enough to recover the forests



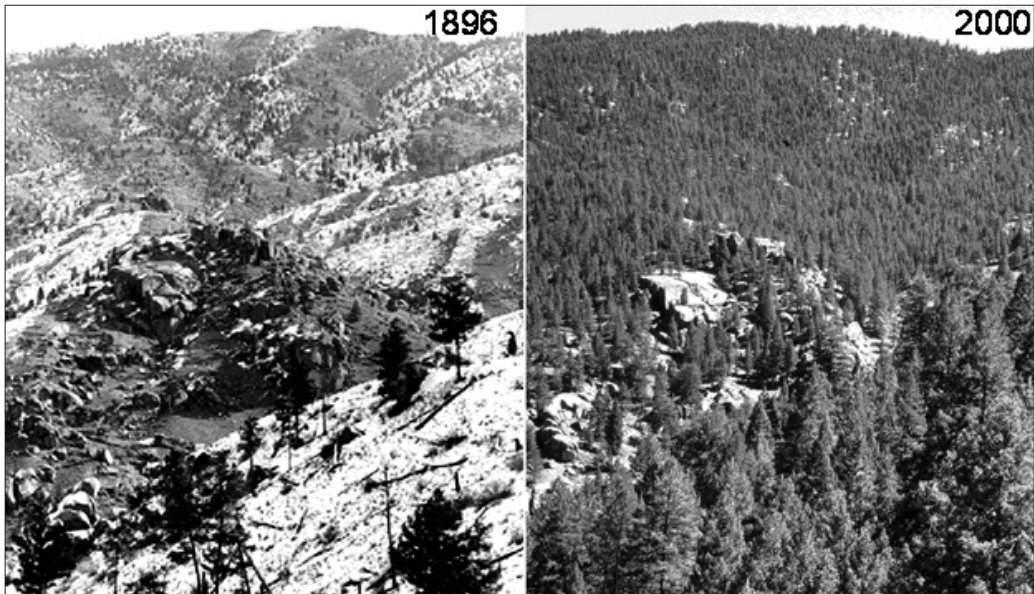

*Fig. 2: Fires once every two decades or so kept some ponderosa pine forests open, with diverse and productive understories (left, picture from Denver Water Board). A century without fire allowed more than a 10-fold increase in tree numbers, basal area, and canopy fuels (right, picture from Merrill Kaufmann). Two years after the photo was taken, a stand-replacing canopy fire converted the hillside to a meadow; forest recovery will be a very slow process owing to a lack of surviving trees to provide seeds (photos from Denver Water Board (left) and Merrill Kaufmann (right); [http://www.cfri.colostate.edu/docs/cfri\\_ponderosa.pdf](http://www.cfri.colostate.edu/docs/cfri_ponderosa.pdf)).*

if browsing by elk (same species as red deer in Europe) is not severe. The cause of the sudden aspen decline is not known with certainty, but extremely dry and hot conditions in 2002 to 2004 are suspected (Colorado Forest Restoration Institute; [http://www.cfri.colostate.edu/docs/aspen\\_change.pdf](http://www.cfri.colostate.edu/docs/aspen_change.pdf)). At the same time, many pinyon-juniper woodlands shifted to primarily juniper woodlands, as the less-drought-tolerant pines died on hundreds of thousands of hectares.

### *People and communities*

The population of Colorado increased from two million in 1970 to five million in 2008, a rate of population growth of 2.5% annually. Colorado has attracted new residents with a desirable climate (almost 300 days of sunshine, moderate winters and summers), dramatic scenery (more than 50 peaks taller than 14,000 feet (4270 m)), and moderately strong economy. None of these factors is likely to change, so rapid population growth will likely continue.

Historically, people were concentrated in the major cities and towns at lower elevations, but the recent influx of people led to major increases in the numbers and density of forest residents. Most forest development has occurred at lower elevations, where the risks of wildfire are particularly severe. In 1960, Colorado had 475,000 ha of low density residences (1 to 10 houses/ha). This value rose to over 150,000 ha in 2000, and will likely growth to 200,000 to 300,000 within one to several decades. A “wildland-urban interface” (WUI) can be estimated, accounting for the proportion of this low-density development that occurs in the mountains (not including the plains), and the area within 1.5 km of houses. In 2005, the WUI comprised more than 300,000 ha, and this area is expected to triple by 2030 (D. Theobald, unpublished information; <http://www.nrel.colostate.edu/~davet/wui.html>).

### *Climate*

Climate warming in Colorado was complex in the 20<sup>th</sup> century. Across the state, spring temperatures rose by about 1°C from 1950 to 2000 (climate information from Wolter and Doesken, 2006; <http://www.colorado.edu/resources/klaus.wolter.Colorado.temps%20v2.pdf>). The rate of warming appeared to accelerate in the past 30 years, although the change in the rate of warming was not statistically significant. In the southwestern part of the state, with the highest mountains and largest snowfall, springtime maximum temperatures increased by about 2°C from 1950 to 2000; summer maximum temperatures cooled by about 1°C, and winter and autumn maximum temperatures showed no trends. Similarly, springtime minimum temperatures rose by about 2°C from 1950 to 2000, with little change in minimum values for other seasons.

Precipitation is far more variable than temperature at times scales of years and decades. The coefficient of variation in precipitation is about 15% for Colorado, and droughts are common. More than half the state experiences a substantial drought every 20 to 30 years, with droughts typically lasting one to 5 years. High variation among years and decades makes it difficult to detect long-term trends, but at least some mountain locations saw a 20% decline in precipitation through the 20<sup>th</sup> century.

These trends in temperature and precipitation have led to substantial changes in Colorado’s hydrology. The rise of rivers with snowmelt in the spring shifted about 5 to 10 days sooner by the end of the 20<sup>th</sup> century, and the peak in snowmelt occurs one to two weeks sooner (Stewart et al. 2005). However, the implications of climate

changes are unclear for Colorado forests. Warmer temperatures might be expected to increase drought stress on trees, but across the state the potential evapotranspiration showed a declining trend in the late 20<sup>th</sup> century as a result of increased relative humidity and lower surface wind speeds. Weather affects more than just the water physiology of trees; warmer winter temperatures may play a role in supporting higher populations of forest insects such as mountain pine beetles, with major impacts (and legacies) on forest ecosystems.

### *Connections*

Forests, people, and climate connect in simple and complex ways. The historic conditions in forests resulted largely from interactions with climate, including drought years where large proportions of landscapes burned. Humans and livestock reduced fire frequency and extent in the 20<sup>th</sup> Century, but the continued accumulation of unharvested forest biomass may lead to more extensive and severe fires when droughts occur. Even in the absence of fire, droughts and changing temperatures may combine to stress trees and favor bark beetles and other mortality agents.

Climate-driven changes in forests also connect to concerns about water yields and economies. Colorado's mountain economies rely heavily on tourism, and winter sports are particularly important. A projection of impacts for the ski resort in Aspen, Colorado included later development of snowpack (and onset of skiing season) by 2 weeks by 2030, along with thinner snowpacks, increased snowpack density (and poorer quality skiing), and four week sooner melting in spring (Aspen Global Change Institute 2006). These climate-driven changes might reduce the economic value of the ski industry by more than 50% in the next 20 years.

The forests and communities of the Rocky Mountains have undergone profound changes over the past 2 centuries, as a result of changes in population, cultures, policies, land management, and climate. In the past ten years, a variety of place-based citizen collaborations developed around Colorado, aiming to improve management of public lands, as well as the integration of land management into landscape-based approaches that encompass multiple ownerships (Colorado Forest Restoration Institute; <http://www.cfri.colostate.edu/partners.htm>). These collaboration groups will be fundamental to informing people (including forest managers) about changes in forests, and developing the social and political basis for active responses.

The forests of Colorado will be different in the 21<sup>st</sup> century, and climate changes may be a major contributor to a cascade of ecological and social interactions.

## Global Change and Sustainable Development in Mountain Regions

*Table 1: Nine points uniting forests, people, and climate in Colorado*

---

1	An intimate matrix of public and private lands complicates active forest management.
2	Colorado is an attractive place to live, and population growth averages 2.5% annually.
3	The increase in population has driven an even larger amount of new development of houses and towns in the mountain forests.
4	Development has led to a massive wildland-urban interface of 300,000 ha, and the WUI is likely to triple within 2 decades.
5	Colorado has six major types of forests, with varying natural histories and fire regimes
6	One million ha of low-elevation forests pose a major fire risk as a result of a century (or more) without fires.
7	Most forest types are in a period of rapid change, from fires, bark beetles, and drought; the current changes may be driven partially by changing climate.
8	Changing climates will change the economic base of mountain communities, especially if snowfall lessens and snow pack melts sooner.
9	The future forests cannot be controlled by management, but place-based forest collaborative groups may play a major role in helping shape forest landscapes.

---

Forests commonly change at time scales of decades and centuries, and changes are not automatically good or bad. We may have the opportunity to influence some of these changes, so discussions about mountains, forests, and people will be the cornerstone for understanding, adapting, and influencing our future.

### *For more information:*

- Aspen Global Change Institute. 2006. Past and Future Changes in Aspen's Climate (<http://www.agci.org/>)
- Peet, R.K.. 2000. Forests and meadows of the Rocky Mountains. In: North American Terrestrial Vegetation, Barbour, M.G. and Billings, W.D. eds. Cambridge University Press, New York. pp. 75-122.
- Shepperd, W.D., D. Binkley, D. Bartos, T.J. Stohlgren, and L.G. Eskew (eds). 2001. Sustaining Aspen in Western Landscapes. USDA Forest Service General Technical Report RMRS-P-18. 460 pp.
- Stewart, I.T., D.R. Cayan, and M.D. Dettinger. 2005. Changes toward earlier streamflow timing across western North America. *Journal of Climate* 18:1136-1155.
- Theobald, D. Land-use website (<http://nrel.colostate.edu/~davet/>)
- Veblen, T.T., K.S. Hadley, E.M. Nel, T. Kitzberger, M. Reid, and R. Villalba. 1994. Disturbance regime and disturbance interactions in a Rocky Mountain subalpine forest. *Journal of Ecology* 82:125-135.

# Transfer of Forestry Expertise Between Mountain Regions

Robert Jandl <sup>1)</sup>, Helga Van Miegroet <sup>2)</sup>, Alexander Ač <sup>3)</sup> and Radek Pokorny <sup>3)</sup>

<sup>1)</sup> Bundesforschungs- und Ausbildungszentrum für Wald, Naturgefahren und Landschaft (BFW), Seckendorff Gudent Weg 8, A-1131 Wien, Österreich

<sup>2)</sup> Department of Wildland Resources, Department of Watershed Sciences, Utah State University, Logan UT, U.S.A.

<sup>3)</sup> Institute of Systems Biology and Ecology, Academy of Sciences of the Czech Republic, Brno, Czech Republic

## *Introduction*

Mountain regions around the globe provide numerous ecological and economic services such as drinking water for lowlands; natural resources that are used in agriculture, forestry, and mining; recreation and scenic beauty; wildlife habitats; carbon sequestration and biodiversity (Daily et al., 1997; Baron et al., 2002; Schröter et al., 2005; Naidoo et al., 2008). Many are undergoing shifts away from traditional land uses due to changing economics and/or societal demands. Natural hazards play an important role in their dynamics (McGuire, 2008, Kurz et al. 2008). Here we explore similarities between the Alps, the Carpathian Mountains, and the central part of Rocky Mountains in the western U.S., in order to evaluate whether experiences in land management in one region can be applied to the other region. The expectation is that potential pitfalls can be avoided and successful examples can be transferred.

The three regions were chosen because they represent examples of economies that were originally largely resource based but have undergone important shifts in the last 50 years. Similarities between the Alps and the Carpathian Mountains are already utilized in the Alpine Convention (<http://www.alpineconvention.org>), a comprehensive framework for land use in the Alps that serves as a conceptual template for the presently emerging Carpathian Convention (<http://www.carpathianconvention.org>). All three regions are rich in forests, have historically been exploited by a mining industry, and now have tourism as an important economic driver.

### *Societal demands*

The people in mountain regions, in a global comparison, have traditionally suffered from economic disadvantages, and could even be called the poorest of the poor. The reliance of the local resources and the bucolic life style has often been narrated. Due to climatic constraints, agriculture and forestry in high elevation is less lucrative than in lower elevations. Furthermore, increasing mechanization of agriculture and forestry enables more efficient (and less labor-intensive) land management. As a consequence, the mere conservation of traditional agricultural mountain landscapes has often become economically unsustainable. As the traditional land uses disappear, and society in general becomes more affluent, increasing recreation and tourism provides a new economic stimulus to mountain regions. However, with this new source of income also comes increasing share of a more demanding population with an urban life style (Moser and Peterson, 1981, Haas, 2008), and higher demand for infrastructure and services.

While the population of rural area has generally declined, the population in the foothills of mountain ranges has increased, creating an urban-wildland interface (UWI) with new management challenges. An increasing number of people, often retaining their economic ties to cities, find retiring to or living in a rural environment increasingly attractive, but demand full access to the amenities of a city, and require non-traditional infrastructure. Commuters, in particular, generate a substantial amount of road traffic.

Fourteen million people are currently living in the Alps, 60% of them living in cities, and 80% with employment either in cities or in tourism. Nine percent of the Austrian Gross Domestic Product is generated in tourism, which is the highest share on all industrialized nations (WKÖ, 2008).

In the valleys between the mountains and on the northern slopes of the Western Carpathians, the population density is high, whereas, close by, practically uninhabited mountain ranges are found. On the whole, the Southeastern Carpathians are less densely settled than the Western Carpathians. The hotly debated topic is the establishment of secondary homes (Kozak, this issue). The road system is currently expanding for the sake of creating an economic stimulus from tourism. It is safe to predict that transit traffic on pan-European corridors will develop into a controversial issue.

The Rocky Mountains are a good example of the complex role of roads in UWI management, including protection from natural hazards. Establishing a rich infrastructure for private car traffic is generally undisputed. Traffic issues are generally less severe than in the Alps, as the mountains are crossed by only a few major traffic arteries, and the valleys with highways are wider than in the Alps. On the other hand, this less dense road network poses a significant challenge during wildfires when the protection of sensitive structures and the safety of the inhabitants in the UWI becomes of critical importance.

### *Landownership*

A decisive role on land use is coming from landowner ship. In the Alps in Austria forest is typically privately owned. Forestry has a long history and timber was in high demand (Johann, 2002).

Forest management in Carpathians has a long history and human influence and harvesting of the wood can be traced into Mesolithic age (CEI, 2001). Forest landownership is country specific. In Slovakia, the previous percentage of public ownership of forests of almost 90 % was reduced to 40 % after the fall of communism (2004). Now, more than 10 % of forest is in the highly fragmented private sector (Frič and Pilná, 2005). In Romania, more than 85 % of forests are owned by the state and managed by National Forest Administration (Georgescu and Daia, 2002). In Ukraine, till 1917 about 70 % of forests were in private ownership and deforestation was a problem. In 1918, the forests were nationalized and forest area as well as growing stock substantially increased.

The intensive exploitation in the Rocky Mountain region started relatively late (late 1800) and that the majority of the forest and rangelands are on public lands, with private owners accounting for less than one quarter of the timberland resources (Price, 1976; Morgan et al., 2006). While use these public lands have traditionally been made available to private ranchers to graze their cattle and sheep through a permitting system, the management of the forest largely remained the mandate of federal land management agencies. Consequently, management is dictated by a strict set of regulations (e.g., Forest Management Act, Threatened and Endangered Species Act), often reflecting changing societal needs and demands.

### *Characteristics of land use / forestry*

#### **Alps:**

In the Alps the central paradigm of land use is multifunctionality. In addition to achieving high productivity, natural hazard control is also an important goal in management, often at odds with the first one. Several times in history the reduction of the forest cover, driven by the demand for agricultural land, timber for mining, and fuel wood for industry, had brought in its wake natural disasters such as flooding, erosion, and avalanches (Glatzel, 1994).

Under the present economic situation, agriculture has lost importance and permanent grassland and forests are encroaching abandoned alpine pastures (Johann, 2002; Russ 2004; Tasser et al., 2007; Borsdorf and Bender, 2007; Hunziker et al., 2008). These forests are mostly coniferous and have a low growth rate. Especially where forests have no protective function their management will become less intensive (Broggi, 2002), especially when job opportunities outside of forestry are more attractive. Even extensive forest management has to care for the choice of appropriate tree species (retention of precipitation in the canopy; transpiration of soil water; longevity) and the maintenance of an optimised stand structure (Mayer, 1976; Bebi, 1999). Low harvest rates have already led to an over-maturity of high-elevation forests.



Active forest management is also important for the detection of undesired developments. Only recently has a climate-change related migration of bark beetles into mountain forests been observed, whereas this type of natural disturbance has remained less important role to forest dynamics in the past (Schwerdtfeger, 1981). Effective control requires a monitoring system and additional mitigation efforts that further impose an economic pressure on forest owners. Ignoring bark beetle infestations would invariably lead to a dieback of stands, exposure of the surface, and soil erosion (Figure 1), which in turn jeopardizes the inhabitability of the land.

*Fig. 1: Soil erosion in the wake of the disintegration of mountain forest after bark beetle attack. Picture: Austrian Alps, courtesy of Markus Neumann (BFW).*



### **Carpathian Mountains:**

Large parts of the Carpathian Mountains have a history of small-scale agriculture. Presently, 60 % of the surface is forested, with deciduous tree species dominating. Twenty seven percent are in agricultural use (Ruffini et al., 2006). The Carpathian montane beech forests have undergone less intensive exploitation by humans and consequently the tree species composition is generally much less changed than in Western Europe. The percentage of beech has decreased in favor of conifers due to demand for softwood. At present, the forests are usually managed by different systems and clear cutting is still common (BFH, 2007). Traditional sustainable village system in Ukraine's Carpathian Mountains are successful since centuries (Elbakidze and Angelstam 2007). As a consequence of management, many forests are close to the potential natural vegetation. In the wake of political change between 1988 and 1994, forest cutting rates have nearly doubled, associated with increased forest fragmentation. Since 1994 cutting rates decreased to lower rates. (Kozak, this volume; Kümmerle et al., 2007). At the same time, the forested area as well as the area of protected forests (from less than 8 % in 1950 to more than 15 % in 2007) is increasing in Slovakia (Green Report, 2007). In Romania, about 10 % of forests are currently managed without harvest cuttings.

In the long term, climate change is viewed as the most significant threat to Carpathian forests (BFH, 2007). For instance, recent pest outbreaks in parts of Carpathian region are of increasing concern as well as challenge for forest management (e.g., Zúbrik et al, 2005). Combination of wind disturbance and subsequent pest damage on standing trees (e.g., in High Tatras in Slovakia) will cost more than 46,5 mil. € by 2013 in Slovakia alone, in order to prevent further economic damage to Carpathian managed forests of Norway Spruce (*Picea abies*).

### **Rocky Mountains:**

As in many areas of the western US, forestry in the classical sense has been discontinued in the Rocky Mountains. Between 1850 and 1920 extensive logging and human-set fires have reduced old-growth forests (Stohlgren et al., 2000). Post-WWII timber extraction reached its peak during the 1960s, but has declined since, mostly due to a reduction in the timber derived from National Forest lands. Two-thirds of the timber processed in Colorado is now harvested on private and tribal lands, whereas the National Forests were major contributors in the 1970s and 1980s, accounting for 80-90% of the timber harvests (Morgan et al., 2006) For example, current harvest levels in Colorado fulfill only half of the timber processing capacity in the region

(Morgan et al., 2006). Nationwide timber demands are now mostly supplied by areas with higher productivity such as the southeastern U.S. Whereas in Europe governments are directly or indirectly subsidizing forestry, traditional forestry in the U.S. has given way to other forms of land use. With the disappearance of timber production, has come a paradigm shift in forest management towards other ecosystem services such as the conservation of natural habitats for wildlife and threatened and endangered species and the maintenance of scenic beauty for recreation.

The Rocky Mountains are characterized by a distinct climatic gradient with elevation from xeric to mesic, reflected in the composition and structure of forests and woodlands, and the natural fire regime (Binkley, this volume). The intense wildfire season of 1910, when more than 1.5 million hectares of forest burned in the Rocky Mountains, signaled the beginning of the era of active fire suppression in the region (Keane et al. 2002), which had important consequences for forest development in much of the 20<sup>th</sup> century. This has resulted in a change in the forest structure towards denser stands, especially in the low-elevation ponderosa pine forests. Fire suppression policies, declines in harvesting volumes, and beetle-caused mortality result in the accumulation of dead wood that can fuel a wildfire. While there is some salvage timber harvesting [e.g., dead timber was 28% of timber harvest in Colorado in 2002, vs ~ 8 % in 1982 (Morgan et al. 2006)], little revenue is generated in the process, as there is little local demand for the timber. The closure of forest enterprises has several consequences. Without local supply the timber processing industry went away. The expectations in the skills for forest engineers in that region have changed. Main issues are habitat management and biodiversity. Expertise in silviculture is sought to a lesser degree. The landscape develops from a managed forest ecosystem to a wilderness area. The difference with respect to scenic beauty may be subtle, but the response time to avert undesired dynamics does differ. Already in history the rather extensive forest management dealt with insect outbreaks always in a rather passive way. It was always seen as a part of the natural forest dynamics that cannot be controlled in an economic way.

### *Ecosystem services linked to forestry*

In the three mountain regions, the declining production of wood is balanced by an increasing demand for other ecosystem services (EEA, 2008), several of which still require active forest management (Gret-Regamy et al., 2008). The dilemma of assigning value to these services in a market economy stems from the fact that

there is no clear market relation between provider and customer. Although many are benefiting directly, it is difficult to single out an economically potent group of beneficiaries from whom monetary compensations can be claimed. Valuation of non-market price services in natural resources is a relatively new field in economics. A recent survey has shown that ecosystem services were ranked in descending order of esteem as follows: biodiversity, scenic beauty, timber production, watershed protection, and carbon sequestration. When asked for which of these ecosystem services one would be willing to pay directly, the sequence changed to carbon sequestration, watershed protection, biodiversity, and scenic beauty (Joachim Sell, Pers. Commun; Koellner and Scholz, 2007).

The role of mountains as *water towers* for the underlying lowlands is well known (Weingartmann, this issue). Water may be the single one commodity that has the most direct economic value. Forest management has numerous effects on the hydrology. The effects range from (1) retention of water at the site, (2) lowering the peak flow of floods, and (3) enhancing the chemical water quality. In Austria, 50% of the total water demand comes from mountains; in the Rocky Mountains the montane and subalpine ecosystems supply as much as 25% of the freshwater supply for agriculture and domestic use (Stohlgren et al., 2002).

Mountain forests are locations of high carbon retention, and the main issue in management is the preservation of the existing carbon stocks. In addition, the change in the carbon stocks of managed land in Europe is reported according to the Kyoto Protocol (IPCC 2006), while no such standardized reporting system is currently in place in the U.S. Land-use change such as the reforestation of alpine pastures will lead to an increase in the aboveground carbon pools, but the effects of land use and vegetation change on soil carbon are often less certain and far from consistent (Guo and Gifford, 2002).

Forests offer protection against natural hazards such as avalanche, flooding, landslides and increasingly rockfall. The protection encompasses both human life and infrastructures (e.g. roads, railways, energy supply lines). Due to the comparably high population density in the valleys of the Alps, comprising both local population and tourists, roads are kept open almost permanently. Experience has proven that intact forest ecosystems often are an economic way of providing the desired protection. In many regions forests are expanding and appropriate forest management is necessary to ensure its effective protective function. Only in areas where new skiing slopes are developed is forest cover declining, and these land-use changes are currently scrutinized by the authorities.

Figure 2 shows a farmhouse in a high elevation dwelling in the Austrian Alps. The steep slope above the building is partly forested and extends to the timberline. Such locations require protective measures against land slides and avalanches and expensive infrastructures would be needed to replace the function of the forest. The Carpathian Mountains play an important role in the regional hydrology. Several catastrophic floods in the recent past in the lowlands have shown that any retention of water in intact forest ecosystems is important. Furthermore, the area has recently been affected by storms that lead to regrettable losses of income in forestry. Otherwise, the natural hazard situation is considered less critical than in the Alps, mostly because the mountain range is less high and has less steep slopes (Ruffini et al., 2006), which cause avalanches to be generally less of a problem.



*Fig. 2: Farmhouse in Poschach, Ötztal, Austria. The buildings are ducked behind large geologic outcrops and are well protected against avalanches. Piles of timber, hay stacks, and the managed pasture land give evidence for the ongoing emphasis on forestry and agriculture.*

In the Rocky Mountains fire constitutes the most severe natural hazard. Avalanches pose less of a problem to infrastructure and human life, because the relief ratio is generally smaller than in the Alps, and valleys at the bottom of steep slopes are often unpopulated and seldom contain major roads. On the other hand, the fire danger is increasing, due to a combination of past fire suppression policies, drought cycles, widespread insect attacks general changes in the forest structure. Particularly the accumulation of woody debris on the ground can dramatically fuel severe fires (Binkley, this issue).

### *Summary*

The dominant factor affecting forestry in the compared mountain regions is the expectation of the society. A changing economic background is changing the role of forestry. In the past the economy was defined by the locally available resources. Whenever the forest cover was too low, the regions suffered from natural catastrophes such as erosion, flooding, avalanches. Through a trial & error process and an increasing scientific fundament forest management has been optimized so that simultaneously the timber production and protection could be achieved. Since several decades local timber production in mountain regions is becoming less relevant. However, active forest management cannot be abandoned because it ensures several ecosystem services that are otherwise not ensured. Novel concepts of land management are required that are geared to the provision of ecosystem service and still are economically sustainable. The three compared region are arranged along a gradient of economic wealth. Common is that forestry, as a part of the primary economy, is losing relevance when the economy improves. The natural settings and external pressures in the compared regions are different. However, we encounter as a similarity that an active forestry is an efficient way of maintaining and controlling the landscape.

A common challenge for the compared mountain regions is to face the Urban-Wildland-Interface appropriately. The regions differ with respect to the legal framework. In Europe private land development is based on stringent regional planning principles. The development of private land is therefore a highly controlled process. Land owner face numerous restrictions for the sake of a public interest. In the United States, instead, land ownership is highly valued and widely unrestricted by legal matters. The development of private land is therefore mostly a personal decision. Permanent homes can be established at locations even when an expert would, in recognition of natural hazards, strongly advised against it.

On public land the differences of the regions are in the complexity of the legal framework. It is undisputed that active silviculture can create and sustainably maintain a forest stand structure that diminishes the danger from natural hazards. In the Alps and the Carpathian Mountains the same laws apply for public and private land. The Austrian Forest Act is an example of strictly defining the dos and do-nots on land use in mountain regions, based on the paradigm of sustainable forestry. In the United States a challenge is the over-regulation of public land. Numerous laws are valid and not prioritized and allow stakeholders to express per se valid but contra-

dictory claims on land use. Land managers in the Rocky Mountains find themselves locked between the interests of many stakeholders and have difficulties to implement the principles of sustainable forestry.

The loss of the expertise in forestry has different consequences in the compared regions. In the Carpathian Mountains the forestry sector is strong and presently not jeopardized. In the Alps the revenue generated by timber production hardly covers the production costs. Forestry is an integral part of the control of natural hazards. Forgoing forestry would lead to tremendous problems in the protection of infrastructure and lives. In the Rocky Mountains the loss of active silviculture is already reality. However, the pressure from natural hazards is less accentuated than in the Alps, mostly due to the low population density, less infrastructure, and the smaller relief energy in the mountain regions.

*Table 1: Similarities and dissimilarities between different mountain regions with consequences on forest practices.*

<b>Factor</b>	<b>Carpathian Mountains</b>	<b>Alps</b>	<b>Rocky Mountains</b>
Traffic	Efforts to increase accessibility	Perceived as major problem; efforts to ban/limit transit traffic	Few major gateways crossing W-E; Not perceived as problem, except in the case of fire hazard
Agriculture			
Forestry	Viable economy	Only marginally productive/ increased efforts to ensure sustainable forestry	Forestry widely given up for economic reasons and due to regulatory constraints / more emphasis on habitat management
Insect outbreaks in forests	Monitoring, control at high costs	Monitoring, control at high costs	Seen as natural part of ecosystem dynamics; few counter measures
Natural Hazards	Flooding	Torrents and avalanches	Fire
Ecosystem services	Water tower, carbon sequestration; tourism	Water tower, carbon sequestration; tourism	Habitat; water; tourism
Society	Currently depopulation of traditional population; summer homes	Increasing population, mostly in urban centers	Ski resorts, major cities (Denver, Salt Lake city, Boulder)
Land ownership	Forests on public land	Private forest; community forest	Forests on public land

## References

- Baron, J. S.; Poff, N. L.; Angermeier, P. L.; Dahm, C. N.; Gleick, P. H.; Jr., N. G. H.; Jackson, R. B.; Johnston, C. A.; Richter, B. D. & Steinman, A. D. Meeting ecological and societal needs for freshwater *Ecological Applications*, 2002, 12, 1247-1260
- Bebi P. 1999. Erfassung von Strukturen im Gebirgswald als Beurteilungsgrundlage ausgewählter Waldwirkungen. PhD thesis, ETH Zürich.
- Borsdorf, A. & Bender, O. Kulturlandschaftsverlust durch Verbuschung und Verwaldung im subalpinen und hochmontanen Höhenstockwerk: Die Folgen des klimatischen und sozioökonomischen Wandels. *Innsbrucker Geographische Gesellschaft, Sonderheft Hugo Penz*, 2007
- Broggi, M. F. Alpine Space: A challenge for research. *Centralblatt für das gesamte Forstwesen*, 2002, 119, 247-254
- Carpathian Ecoregion Initiative (CEI), WWF report, 2001, 68 pp.
- Daily, G. C.; Alexander, S.; Ehrlich, P. R.; Goulder, L.; Lubchenco, J.; Matson, P. A.; Mooney, H. A.; Postel, S.; Schneider, S. H.; Tilman, D. & Woodwell, G. M. Ecosystem services: benefits supplied to human societies by natural ecosystems. *Issues in Ecology*, 1997, 2, 1-16
- EEA. European forests - ecosystem conditions and sustainable use: *EEA Report No.3*, 2008
- Elbakidze M, Angelstam P (2007) Implementing sustainable forest management in Ukraine's Carpathian Mountains: The role of traditional village systems. In. Elsevier Science Bv, pp 28-38
- Federal Research Centre for Forestry and Forest Products (BFH). The conditions of forests in Europe, Executive report, 2007.
- Frič, L.; Pilná, I (ed). Lesy na Slovensku. National Forest Centre, Zvolen, 2005, 16 pp.
- Guo, R.M. and Gifford, L.B. Soil carbon stocks and land use change: a meta analysis. *Global Change Biology*, 2002, 8, 345-360.
- Glatzel, G. Leben mit dem Wald: Österreichs Wälder im Wechsel der Zeiten In: Morawetz, W. (ed.), *Ökologische Grundwerte in Österreich - Modell für Europa?*, *Österreichische Akademie der Wissenschaften*, 1994, 289-303
- Green Report – Report on the status of forestry in the Slovak Republic 2007, (Eds Moravčík, M.) National Forest Centre – Forest Research Institute, Zvolen, 175 pp.
- Georgescu, F.; & Daia, M., L. Forest regeneration in Romania. *Revista Padurilor*, 2002, 117, 1-5.
- Gret-Regamey, A., Watz, A., Bebi, P. Evaluating ecosystem services for sustainable landscape planning in alpine regions. *Mountain Research and Development*, 2008, 28 (2), 156-165.
- Haas, W. (ed.) Integrative Forschung im Ötztal. Footprints future past present. Endbericht. Institute for Social Ecology, *Universität Klagenfurt* 2008
- IPCC. Good Practice Guidance for LULUCF. 2006 <http://www.ipcc.ch/ipccreports/methodology-reports.htm>
- Hunziker, M, Felber, P., Gehring, K., Buchecker, M, Bauer, N., Kienast, F Evaluation of landscape change by different societal groups. Results of two empirical studies in Switzerland. *Mountain Research and Development*, 2008, 28 (2) 140-147.
- Johann, E. Multiple use forestry and utilisation conflicts in history. *Centralblatt für das gesamte Forstwesen*, 2002, 119, 191-203.
- Keane, R.E.; Ryanm K.C.; Veblen, T.T.; Allen, C.D.; Logan, J. ; Hawkes, B. Cascading effects of fire exclusion in Rocky Mountain ecosystems: A literature review. USDA Forest Service, Gen. Tech. Rep. RMRS-GR-91 Forest Service, Rocky Mountain Research Station Fort Collins, CO., 2002.

## Global Change and Sustainable Development in Mountain Regions

- Koellner, T. & Scholz, R. W. Assessment of Land Use Impacts on the Natural Environment Part 1: An Analytical Framework for Pure Land Occupation and Land Use Change *Int J LCA*, 2007, 12, 16-26
- Kuemmerle, T.; Hostert, P.; Radeloff, V. C.; Perzanowski, K. & Krühlov, I. Post-socialist forest disturbance in the Carpathian border region of Poland, Slovakia, and Ukraine. *Ecological Applications*, 2007, 17, 1279-1295
- Kurz WA et al. (2008) Mountain pine beetle and forest carbon feedback to climate change. *Nature* 452:987-990
- Mayer, H. Gebirgswaldbau – Schutzwaldpflege. *Gustav Fischer Verlag*, 1976
- McGuire, D. Education and capacity building. In international conference Mountain forests in a changing world. April 2-4, 2008, Vienna
- Morgan, T.A., T. Dillon, C.E. Keegan, A.L. Chase, M.T. Thompson. The four corners timber harvest and forest products industry, 2002. USDA Forest Service, Resour. Bull. RMRS-RB-7. USDA Forest Service, Rocky Mountain Research Station Fort Collins, CO., 2006.
- Moser, W. & Peterson, J. Limits to Obergurgl's growth. *Ambio*, 1981, 10, 68-72
- Naidoo, R.; Balmford, A.; Costanza, R.; Fisher, B.; Green, R. E.; Lehner, B.; Malcolm, T. R. & Ricketts, T. H. Global mapping of ecosystem services and conservation priorities. *PNAS*, 2008, 105, 9495–9500
- Price, R.. History of Forest Service Research in the Central and Southern Rocky Mountain Regions, 1908-1975. For. Serv. Gen. Tech. Rep. RM-27, USDA Forest Service, Rocky Mountain Research Station Fort Collins, CO., 1976
- Ruffini, F. V.; Streifeneder, T. & Eiselt, B. Implementing an international mountain convention - An approach for the delimitation of the Carpathian Convention area. *EURAC*, 2006
- Russ, W. Mehr Wald – ein positiver Trend? BFW Praxisinfo, 2004, 3, 4-7
- Schröter, D.; Cramer, W.; Leemans, R.; Prentice, I. C.; Araújo, M. B.; Arnell, N. W.; Bondeau, A.; Bugmann, H.; Carter, T. R.; Gracia, C. A.; de la Vega-Leinert, A. C.; Erhard, M.; Ewert, F.; Glendining, M.; House, J. I.; Kankaanpää, S.; Klein, R. J. T.; Lavorel, S.; Lindner, M.; Metzger, M. J.; Meyer, J.; Mitchell, T. D.; Reginster, I.; Rounsevell, M.; Sabaté, S.; Sitch, S.; Smith, B.; Smith, J.; Smith, P.; Sykes, M. T.; Thonicke, K.; Thuiller, W.; Tuck, G.; Zaehle, S. & Zierl, B. Ecosystem Service Supply and Vulnerability to Global Change in Europe. *Science*, 2005, 310, 1333-1337
- Schwerdtfeger, F. Die Waldkrankheiten. Ein Lehrbuch der Forstpathologie und des Forstschutzes. *Verlag Paul Parey*, 1981
- Stohlgren, T. J.; Veblen, T. T.; Kendall, K. C.; Baker, W. L.; Allen, C. D.; Logan, J. A. & Ryan, K. C. In Baron, J. S. (ed.). *The Heart of the Rockies: Montane and subalpine ecosystems*. Chapter 10. *Island Press*, 2000, 203-218
- Tasser, E.; Walde, J.; Tappeiner, U.; Teutsch, A. & Noggler, W. Land-use changes and natural reforestation in the Eastern Central Alps. *Agriculture, Ecosystems and Environment*, 2007, 118, 115-129
- Wirtschaftskammer Österreich (WKÖ) Tourismus in Zahlen. Österreichische und internationale Tourismus- und Wirtschaftsdaten. 44. Ausgabe, März 2008, [http://portal.wko.at/wk/startseite\\_dst.wk?angid=1&dstid=252&opennavid=34384](http://portal.wko.at/wk/startseite_dst.wk?angid=1&dstid=252&opennavid=34384)
- Zúbrik, M., Kunca, A., Turcani, M., Vakula J., Leontovyc R. Invasive and quarantine pests in forests in Slovakia 2005. OEPP/EPPO Bulletin 36, 402-408, 2005. (Paper presented at the EPPO conference on Phytophthora ramorum and other forest pests (Falmouth, Cornwall, GB, 2005-10-05/07).



# Global Change and Sustainable Development in Mountain Regions – The Pacific Northwest Region of North America

Paul Mitchell-Banks

Central Coast Consulting, Vancouver BC, Canada

What makes global change and sustainable development more challenging in the Pacific Northwest, but in some ways more hopeful, is that this is an area characterised by great physiographic diversity and thus also climactic conditions and biodiversity. This suite of habitats and ecosystems/inhabitants creates a range of biodiversity that offers a potential regional ability to absorb an indeterminable amount of global change before there are systems' collapses and potentially profound changes, and if limits or thresholds are reached, an ability for the various appropriate ecosystems to re-stock the recently impacted areas.

The Mountain Pine Beetle (*Dendroctonus ponderosae*) creates devastation directly on the lodgepole pine (*Pinus contorta*) and ponderosa pine (*Pinus ponderosa*) stands and indirectly on the associated forest ecosystems. The habitat flexibility may assist in the resilience of the survival of many species and indeed many habitats. It is a more complicated situation with introduced species, where the physiographic and climactic diversity may facilitate the successful establishment of them, such as the case with the yeast-like fungus *Cryptococcus neoformans* var. *gattii* that originated from the tropical areas, but which seems to have adjusted very well to the temperate habitat of the Pacific Northwest.

There are significant socioeconomic and environmental repercussions of both the local beetle - whose epidemic is potentially going to sweep from British Columbia across the country and the foreign fungus – that is more lethal in the Pacific than in the tropical areas from which it originated. Global change is having profound impacts on this area of the world, and the accounts are still being added up and will be for generations to come.

## *Global Change and Sustainable Development – A Vancouver Perspective*

If you were to ask someone interviewed on a Vancouver street what global change meant to the Pacific Northwest, they might cite climate change as 'evidenced' by

hotter summers and dryer summers, some might suggest that the weather seemed less predictable, the more informed might mention the devastating Mountain Pine Beetle outbreak. While they are likely correct in attributing these two phenomena to Global Change, they would actually be falling far short in understanding the potential magnitude of the impact of Global Change. They would likely have little grasp of the scale and scope of the issues that we, and future generations, will be facing or perhaps more accurately, need to be addressing.

Why is this? Simply put, the situation we face today and in the decades, and indeed centuries to come, stems from activities that have been carried out for decades, and in cases centuries. This has been done either in ignorance (as in the worst case of the word and acting while ignoring the obvious) or through a lack of awareness and understanding. Regardless, we are facing the consequences of a series of actions and inactions that have created a plethora of problems/consequences and their related symptoms which all interact and create the world as we know it, and perhaps even more sobering, as our descendants for many generations will know it.

So how do you begin to approach trying to comprehend such an all encompassing situation? When one begins to think in terms of earth, air, water, and all the interactions, and concepts of bioaccumulation, carrying capacity, limits of acceptable change (which can change), and multiple generations - and this is a rather trite look at the complexity - one's reference points can quickly become obscured. It is very easy to become lost and overwhelmed in terms of data and to have little (or lose what little you had) appreciation for the interrelationships, that may or may not be understood, between the various elements of the ecosystem.

To try and drill things down to a more understandable degree, to essentially create more simple examples, this paper will focus on global change and its impacts, and the impacts in turn, of two organisms. The first organism considered is the Mountain Pine Beetle (*Dendroctonus ponderosae*) an insect that is indigenous to British Columbia and which has traditionally infected lodgepole pine (*Pinus contorta*), a widespread species found throughout the Pacific Northwest. The second is *Cryptococcus neoformans* var. *gattii*, (often referred to simply as 'Crypto', and which I will use throughout the paper) a tropical fungus, historically associated with the Eucalyptus species that has made its way into the temperate forests of the Pacific Northwest.

### *Mountain Pine Beetle Dendroctonus ponderosae*

Lodgepole pine (*Pinus contorta*, and its three subspecies) is an endemic species, known as being highly adaptable to a number of habitat types and found throughout the

Pacific Northwest. It is one of the first species to re-establish after a fire (its cones are opened by the heat) and it is able to live in habitats varying from water-logged bogs to dry, sandy soils. Lodgepole pine is found in varying densities throughout the Pacific Northwest, and its distribution is indicated in Figure 1 below ([http://en.wikipedia.org/wiki/Image:Pinus\\_contorta\\_map.png](http://en.wikipedia.org/wiki/Image:Pinus_contorta_map.png)).

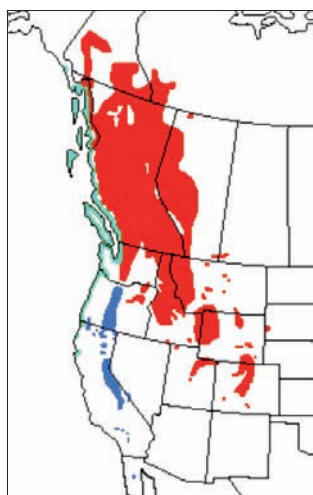

*Pinus contorta* subsp. *contorta*  
*Pinus contorta* subsp. *latifolia*  
*Pinus contorta* subsp. *murrayana*

Fig. 1: Distribution of Lodgepole pine (*Pinus contorta*) in the Pacific Northwest. After Critchfield & Little, *Geographic Distribution of the Pines of the World* US Department of Agriculture Forest Service Misc. Publ. 991 (1966).

Lodgepole pine has historically played an important role in aboriginal cultures, particularly for those First Nations living within the interior of British Columbia who used the poles for the roof structure for pit huts (homes recessed into the soil that one climbed down into). In the spring, they stripped off long strips of the sweet succulent inner bark (cambium layer), and it was eaten fresh in the spring, sometimes with sugar, or stored. The pitch was used as a base for many medicines, and was boiled, mixed with animal fat, and used as a poultice for rheumatic pain and all kinds of aches and soreness in muscles and joints. Pitch was also chewed to relieve sore throats (BC Ministry of Forests and Range website, nd).

Lodgepole pine has also played a significant role in our modern history. In the early development of the province, interior settlers used the wood for cabins, firewood, and fence posts. The railways used lodgepole pine for trestles and ties, the mines for mine props and the pulp and paper industry as a source of fibre, once the challenge of lignin was solved. Lodgepole pine is one of the province's largest sources of dimensional lumber, and is used for doors, windows and furniture (ibid).

There is a well known and documented relationship between lodgepole pine and Mountain Pine Beetle (MPB), with the beetle having been present within BC's forests for millennia, and foresters recording MPB outbreaks since 1910. Evidence of MPB activity for hundreds of years can be found in the scars of lodgepole pine trees in the interior (Taylor and Erickson, nd), though these mature trees are become fewer now with the massive outbreak. Weather plays a key role in the maintenance of Mountain Pine Beetle populations to sub-epidemic levels as information from the BC MoFR website describes,

- In the winter, temperatures must consistently be below -35 Celsius or -40 Celsius for several straight days to kill off large portions of mountain pine beetle populations.
- In the early fall or late spring, sustained temperatures of -25 Celsius can freeze mountain pine beetle populations to death.
- A sudden cold snap is more lethal in the fall, before the mountain pine beetles are able to build up their natural anti-freeze (glycerol) levels.
- Cold weather is also more effective before it snows. A deep layer of snow on the ground can help insulate mountain pine beetles in the lower part of the tree against outside temperatures.
- Wind chill affects mountain pine beetles, but is usually not sustained long enough to significantly increase winter mortality ([http://www.for.gov.bc.ca/hfp/mountain\\_pine\\_beetle/facts.htm#weather](http://www.for.gov.bc.ca/hfp/mountain_pine_beetle/facts.htm#weather)).

Historically forest fires and insects have both played important roles in the natural disturbance and replacement of lodgepole pine forests throughout the province's interior. However, fire control measures that first commenced in the early part of the 20<sup>th</sup> century, to protect the standing timber, infrastructure and private property have resulted in a distortion of age class distribution and an accumulation of old pine forests above historical levels. Mature lodgepole pine trees (typically older than 80 years), are highly susceptible to attack by MPB.

The Canadian Forest Service has estimated that the area of mature lodgepole pine forests is about three times larger than it was in 1910, largely due to fire suppression. In British Columbia in 2003, approximately 14.9 million hectares of the forest was composed of lodgepole pine of all ages, representing approximately one billion cubic metres of merchantable timber (Pedersen, 2003). The area of mature pine forest increased from about 2.5 million hectares in 1910 to over 8 million hectares in 1990 (Taylor and Carroll, 2003).

The second factor has been hot, dry summers and mild winters that have allowed the mountain pine beetle population to reach epidemic levels in mature pine forests. The warmer weather has created favourable conditions allowing the beetle to spread

into higher elevations and more northern latitudes. The drier conditions have created drought-stressed trees in many areas of BC, which increases their susceptibility to beetle attack. One 2002 (British Columbia Ministry of Water, Land and Air Protection, 2002) report indicates that the south and central interior area of the MPB epidemic has experienced average minimum winter temperatures increasing by +2.2°C to +2.6°C over the last 100 years – something projected to continue by some climate models.

If this trend in climate warming continues, then some regions that are currently too cold for the mountain pine beetle are likely to become more suitable – with some potentially significant impacts. Climate cannot be managed, and even suggestions of using silviculture and fire management to address MPB - are perhaps overly optimistic. This over optimism fails to acknowledge the real lack of resources (funding and staffing) available with respect to using silviculture. In terms of fire management, there is the primary issue of massive volumes of standing and downed dead wood from the MPB epidemic and other forest pathologies, to say nothing of the wide dispersal of infrastructure, utility and access corridors and private property throughout the forested areas of the province. The challenge is daunting.

This is not a new beetle to the area, its population has historically risen and fallen in cycles, but we suspect that nothing of this magnitude has occurred to date. Simply put, British Columbia has not recently experienced the severe cold winters and springs required to kill the beetle back and keep the populations to the historically low endemic levels. So what are the repercussions of this change in the weather or climatic conditions? Well, to put it simply, we have had an outbreak, a short description of which is provided below,

During epidemics, widespread tree mortality alters the forest ecosystem. Often, beetles have almost totally depleted commercial pine forests and, in some cases, have converted valuable forests to less desirable timber species, such as subalpine fir. Sometimes, forested areas are converted to grass and shrubs. The profusion of beetle-killed trees can change wildlife species composition and distribution by altering hiding and thermal cover and by impeding movement. Tree mortality may increase the water yield for several years following an infestation. Moreover, the dead trees left after epidemics are a source of fuel that will, in time, burn unless removed. (Amman et al, 2002)

Unusual hot, dry summers in conjunction with mild winters and springs have all contributed to this massive outbreak, which originated in the centre of the province and has now spread throughout much of the north and southern central portions (Figure 2). The gray area in the centre of the outbreak indicates an overrun forest, the range of dark red to pink encompasses those areas that have severe, high, and moderate infestations.

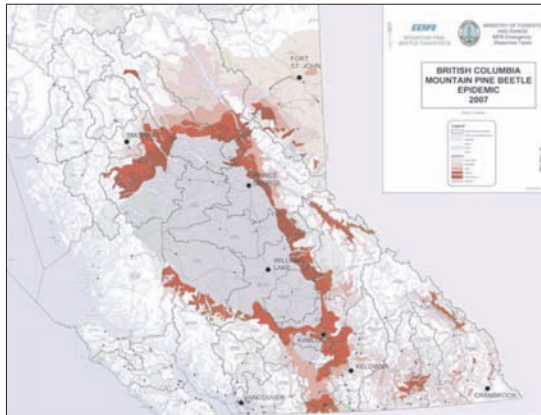

Figure 2. British Columbia Mountain Pine Beetle Epidemic, as of December 31, 2007.

The extent of this outbreak is significant for a number of reasons. The following demonstrates by way of structure, the cascading consequences of the Mountain Pine Beetle Epidemic. For ease of analysis, a breakdown has been made between impacts within British Columbia and impacts outside of British Columbia.

1. The Mountain Pine Beetle Epidemic extends throughout much of British Columbia's interior and has had a profound impact on the environment, economy and communities of people who live not only there but throughout the province. A short list of the provincial environmental, economic and social impacts is provided below:
  - a. Environmental
    - i. Massive die off of lodgepole pine, ponderosa pine and impact on their related habitats and wild-life
      1. Shifting tree and related shrub and herb layer species composition and numbers
        - a. Potential loss of threatened or endangered species and resultant biodiversity impacts
    - ii. Massive die off of lodgepole pine, ponderosa pine and impact on forest physical structure
      1. Reduced canopy resulting in reduced solar insolation
        - a. Reduced snow accumulation
          - i. Reduced release of water during spring and summer
            1. Reduced water levels
              - a. Increased water temperature
                - i. Reduced oxygen levels
                - ii. Impact on salmon spp. spawning success
            - b. Increased snow melt
              - i. Higher flood events during freshet
                1. Impact on level of water
                  - a. Damage to rivers, streams
                    - i. Impact on aquatic and terrestrial species
                2. Increased temperature of water
                  - a. Impact on spawning areas and success of spawning salmon
    - b. Economic
      - i. Massive die off of lodgepole pine, ponderosa pine and impact on forest physical structure
        1. Reduced canopy resulting in reduced solar insolation
          - a. Reduced snow accumulation
            - i. Reduced release of water during spring and summer
              1. Reduced water levels
                - a. Impact on water access for agricultural irrigation
                - b. Potential negative impact on hydrology of ecosystem and resultant economic impacts through decreases in fibre quality and quantity.

- b. Increased snow melt
    - i. Higher flood events during freshet and potential for flooding events
      - 1. Higher water levels
        - a. Damage to rivers, streams
        - b. Increased potential for damage to bridges, dams, dykes, irrigation systems, roads, and communities downstream.
- c. Social/Community
  - i. Massive die off of lodgepole pine, ponderosa pine and impact on forest physical structure
    - 1. Decision to change harvesting practices to 'chase the beetle'
      - a. Harvesting pattern focuses on infected or threatened lodgepole pine stands with pre-existing long-term forestry plans essentially set-aside
        - i. Short term harvest rates generally significantly accelerated in order to recover value of dead or dying lodgepole and ponderosa pine wood and hopefully slow down the spread of beetle infestation
        - ii. Some harvested timber transported longer distances to mills designed to harvest high volumes of small diameter wood to exploit economies of scale, with mills closer to the harvest area not benefiting from increased harvesting rates to the same degree.
          - 1. Long term sustainable harvest rates significantly reduced as a result of massive increase in salvage harvest rate.
            - a. Implications for the long term viability of the community and the reduced long term timber harvest rates
            - b. Forestry employment in the province is uncertain and this has led to contractors deciding to find more certain work in the oil and gas sector
              - i. Some Forestry dependent communities suffering significant economic depression and resident exodus
    - ii. Massive die off of lodgepole pine, ponderosa pine and impact on forest physical structure
      - 1. Reduced canopy resulting in reduced solar insulation
        - a. Reduced snow accumulation
          - i. Reduced release of water during spring and summer
            - 1. Reduced water levels, resulting in reduced water temperature
              - a. Reduced oxygen levels and Impact on spawning success
                - i. Impact on commercial fisheries and fisheries communities
                - ii. Impact on First Nations and their socio-economic and cultural reliance on salmon to sustain them.
- b. Increased snow melt
  - i. Higher flood events during freshet
    - 1. Impact on level of water
      - a. Damage to rivers, streams
        - i. Impact on other species
    - 2. Impact on temperature of water
      - a. Impact on spawning areas and success of spawning salmon
        - i. Impact on commercial fisheries and fisheries communities
        - ii. Impact on First Nations and their socio-economic and cultural reliance on salmon to sustain them.

This has provided a very cursory view of some of the consequences of the potential impacts of the Mountain Pine Beetle epidemic within British Columbia. Obvious impacts have been the decimation of the lodgepole pine and ponderosa pine forests. The recent sub-prime meltdown and stock market/financial market chaos and collapse of the American housing market has had a massive impact on the major market for Canadian forest lumber - a market that is already suspicious of Canadian exports as a result of the longstanding US-Canada Softwood Tariff Dispute. Trying

to dump salvaged MPB lumber into a depressed market is optimistic at best. Less obvious have been the profound impacts on water and salmon, and the very culture of the First Nations who rely on the salmon as part of the culture – for if the salmon swim and spawn within BC’s rivers, it can just as truly be said that they swim within the very blood of the First Nations peoples whose diet is so heavily dependent upon the fish. The loss of the salmon would represent the loss of a key element of the First Nations culture, and how can one put a price to that? How can one estimate the profound impacts on the cultural survival of First Nations who have depended on those fish for millennia?

The Mountain Pine Beetle Epidemic has also crossed over the Rocky Mountains and there is great fear that it could infect jack pine (*Pinus banksiana*) which would then potentially involve an infestation that would cover Canada eastwards to the Atlantic Ocean. See Figure 3 (<http://www.nvwetlands.com/beetle/>). The scale and scope of the impacts would be even further and wider as briefly listed above for the epidemic within the province of British Columbia, but with different elements and aspects.

So what are we doing to try and address this epidemic. This paper is far too short a vehicle to adequately address the strategy and all of its elements. The BC Government Ministry of Forests and Range has a website section on the Mountain Pine Beetle outbreak ([http://www.for.gov.bc.ca/hfp/mountain\\_pine\\_beetle](http://www.for.gov.bc.ca/hfp/mountain_pine_beetle)) and it focuses on a multiyear strategy called the Mountain Pine Beetle Action Plan. It describes as,

...the cornerstone of the Province’s coordinated response to the mountain pine beetle infestation. The Action Plan guides provincial responses and helps coordinate all levels of government, communities, industries and stakeholders working to mitigate impacts of the pine beetle. It addresses forestry and environmental issues as well as economic, social and cultural sustainability (ibid).

The strategy also emphasises,

While accelerated salvage harvesting and reforestation takes place, it will be necessary to carry out reforestation and restoration activities with an awareness of climate trends and long-term risks (ibid).

There are a number of things of concern. We have observed Mountain Pine Beetle infecting fairly recently planted pine stands (some of which the author was involved with while working with First Nations silviculture crews). We still refer to ‘chasing the beetle’ as opposed to having ‘caught’ or ‘controlled’ the beetle, and while the rate of spread may be slowing (largely from a lack of available uninfected trees), there are still other areas that could be recruited with an increase in average temperature. Ultimately, we are at the mercy of Nature itself, and the lead provincial entomol-



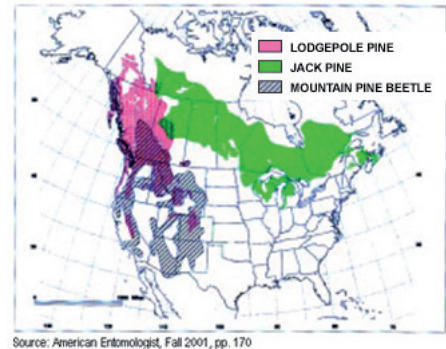

Fig. 3: Distribution of MPB as of 2001 and location of Lodgepole pine and Jack Pine

ogist for Saskatchewan, in the potential path of the Mountain Pine Beetle, and thus closely watching the advance of the epidemic, may have the most realistic outlook on what we can expect in terms of a realistic strategy,

“The best control is nature itself,” says Environment’s McIntosh. “Birds and very cold temperatures, in the -35 to -40 Celsius range over a long period, will kill the beetles, slowing their advance. But one of the best controls is forest fire. Fires are nature’s engine of renewal. Fires remove habitat, including dead and dying trees, kill insects, regenerate the forest and provide homes for the plants and animals that need new growth forest to survive. We may have to step back and, within reason, allow nature to take its course. (McIntosh and Jones, 2008)”

### *Cryptococcus neoformans var. gattii*

The second organism that can serve as an indicator for global change is *Cryptococcus neoformans var. gattii* (often referred to as ‘Crypto’). Crypto is a tropical yeast-fungus historically associated with the Eucalyptus species that has made its way into the temperate forests of the Pacific Northwest. Recent research results have indicated that the *C. gattii* population in B.C. comprises at least two divergent lineages, corresponding to previously identified VGI and VGII molecular types with the nucleotide sequence diversity among isolates from B.C. being similar to that among isolates from other areas of the world (Kidd et al. 2005).

Cryptococcal disease is a very rare disease caused by the *Cryptococcus* fungus. People and animals exposed to this fungus can become sick by breathing in the spores of the *Cryptococcus* fungus. It is not a contagious disease, i.e., not spread from person to person or from animal to person. Cryptococcal disease initially infects the lungs resulting in pneumonia and then can spread through the blood to the nervous system causing meningitis, which is the inflammation of the brain lining. In rare cases, this disease can be fatal.

Most people living in areas where *Cryptococcus* can be found in the environment will be exposed to the fungus sometime during their life, and the vast majority of these people will not get sick. In those people who do become ill, the symptoms appear many months after exposure. Symptoms of cryptococcal disease include:

- A cough lasting weeks or months
- Sharp chest pain
- Unexplained shortness of breath
- Severe headache
- Fever
- Night sweats
- Weight loss

Approximately 25 people in British Columbia now become sick from *Cryptococcus* each year, with one of these cases being fatal. People over 60 years of age and those who take medications that suppress their immune system are at a slightly higher risk of cryptococcal disease (BC Health file #98, 2005).

How did a tropical fungus travel from the southern tropics to the northern temperate zone? A recent study conducted has demonstrated anthropogenic dispersion through air resulting from urban forestry activities such as chipping and physical vectors such as car wheel wells and shoes (Kidd et al. 2007). The potential for peoples' shoes to transport the fungus, and the direct Sydney, Australia –Vancouver, Canada air travel makes that, if not the most likely, then a very likely travel vector for the introduction of this exotic tropical species to the temperate Pacific Northwest. The changing weather patterns, many of whom would argue represent climate change, facilitate the spread of the fungus throughout the Pacific Northwest with the expanding hospitable habitat.

Arguably, Global Change manifests itself in a number of manners in this example, namely:

- Global Change in societies and economies that were previously linked by sea travel but with modern air travel this linkage almost takes on a kind of 'intimacy' in terms of how fast communication and interaction can be.
- Global Change in the movement of exotic species, greatly accelerated by air travel, and perhaps more difficult to manage given the increased numbers of people travelling by air and the focus on convenience and processing time for passengers coming through terminals.
- Global Change in the change of climate that supports the successful establishment of exotic species.

The first documented case of Crypto appeared in Canada on Vancouver Island in 1999 and has since spread to the mainland, and presents in infections in both animals and humans, and can be lethal (Bartlett et al, 2004). In just over two years, by the end of March 2002, a total of 45 laboratory-confirmed animal cases and 50 human cases had been identified. This count only represents those cases that were substantiated by cytological, histopathological, or culture methods, and represents the first report of a large-scale outbreak of cryptococcosis that involved humans, terrestrial animals, and marine mammals (Stephen et al. 2002).

What is of great concern is that the lethality of the fungus appears to have increased in the temperate zone of the Pacific Northwest. In Australia, the infection rate is approximately four per million and rarely fatal, while on Vancouver Island the rate is approximately 27 per million and it was more often killing people (Struck, 2007). Perhaps this is a fourth element of Global Change represented by this organism, in that the lethality has greatly increased, and this is within a decade of its documented arrival in the Pacific Northwest.

### *Summary*

Global Change in the Pacific Northwest presents a myriad of challenges, the vast majority of which remain to be identified, let alone understood. This paper has focused briefly only two indicators of Global change, one a local beetle that has become an epidemic and the second a foreign fungus that has become more lethal and is rapidly spreading. The repercussions of the Mountain Pine Beetle epidemic, and the potential for it to literally spread across Canada to the Atlantic Ocean will not only be disastrous for the forestry sector but also environmentally. Crypto seems to have established itself with a vengeance in the Pacific Northwest and almost reinvented itself into a more virulent form, and we have little understanding of what might be the limits to the scale and scope of its spread – but we know that this presents a very lethal threat. It is as if Pandora's box has been opened, and we cannot push its contents back into it and lock it back up - and even the knocking of Hope, as reputed in the ancient legend, does not offer much for us to hold out for as we grapple with just two of the current challenges we face with Global Change in the Pacific Northwest.

## References

- Alberta Sustainable Resources Development. 2008. Mountain Pine Beetle In Alberta. <http://www.srd.gov.ab.ca/forests/health/pestalerts/mountainpinebeetles.aspx>
- Amman, Gene D., Mark D. McGregor, and Robert E. Dolph, Jr. 2002. Mountain Pine Beetle, Forest Insect and Disease Leaflet 2, United States Department of Agriculture, Forest Service, Reprinted 1990, updated 2002. <http://www.barkbeetles.org/mountain/fidl2.htm>.
- Bartlett, Karen, H., and M. Fyfe, L. MacDougall, C. Duncan, S. Mak, and S. Kidd. 2004. *Cryptococcus gattii*, a tropical pathogen emerging in a temperate climate zone. In the Proceedings of the American Meteorological Society, The 26th Agricultural and Forest Meteorology/13th Air Pollution/5th Urban Environment/16th Biometeorology and Aerobiology, August 22-26, 2004. Vancouver, BC. Canada
- British Columbia Ministry of Health. BC HealthFile #98. 2005 <http://www.bchealthguide.org/healthfiles/hfile98.stm#E46E435>
- BC Ministry of Forests. Nd. Tree Book. Queen's Printer. Victoria. 130 pp.
- British Columbia Ministry of Forests and Range. Nd. Mountain Pine Beetle. [http://www.for.gov.bc.ca/hfp/mountain\\_pine\\_beetle](http://www.for.gov.bc.ca/hfp/mountain_pine_beetle).
- British Columbia Ministry of Forests and Range. Nd. Mountain Pine Beetle. [http://www.for.gov.bc.ca/hfp/mountain\\_pine\\_beetle/facts.htm#weather](http://www.for.gov.bc.ca/hfp/mountain_pine_beetle/facts.htm#weather)
- British Columbia Ministry of Water, Land and Air Protection. 2002 Indicators of climate change for British Columbia, Victoria, B.C.
- Critchfield & Little, *Geographic Distribution of the Pines of the World* US Department of Agriculture Forest Service Misc. Publ. 991 (1966).
- Kidd, Sarah E., Hong Guo, Karen H. Bartlett, Jianping Xu, and James W. Kronstad. 2005. Comparative Gene Genealogies Indicate that Two Clonal Lineages of *Cryptococcus gattii* in British Columbia Resemble Strains from Other Geographical Areas. *Eukaryot Cell*. 2005 October; 4(10): 1629–1638.
- Kidd, Sarah E., Paxton J. Bach, Adrian O. Hingston, Sunny Mak, Yat Chow, Laura MacDougall, James W. Kronstad, and Karen H. Bartlett. 2007. *Cryptococcus gattii* Dispersal Mechanisms, British Columbia, Canada. *Emerging Infectious Diseases Journal*. Volume 13, Number 1–January 2007: 51-57.
- McIntosh, Rory, and Art Jones. 2008. The Mountain Pine Beetle - A Growing Concern. <http://www.environment.gov.sk.ca/Default.aspx?DN=345f140a-746a-4fa3-9f49-e34ea60b31ba>
- Pedersen, Larry. How Serious is the Mountain Pine Beetle Problem? From a Timber Supply Perspective. 2003. In Mountain Pine Beetle Symposium: Challenges and Solutions. October 30-31, 2003, Kelowna, British Columbia. T.L. Shore, J.E. Brooks, and J.E. Stone (editors). Natural Resources Canada, Canadian Forest Service, Pacific Forestry Centre, Information Report BC-X-399, Victoria, BC. 298 p.
- Craig Stephen, Craig, S. Lester, W. Black, M. Fyfe, and Stephen Raverty. 2002. Multispecies outbreak of cryptococcosis on southern Vancouver Island, British Columbia. *Can Vet J*. 2002 October; 43(10): 792–794.
- Struck, Doug. 2007. Alien Invasion: The Fungus That Came to Canada. April 8, 2007 Article in the Washington Post.
- Taylor, Steve and Bob Erickson. Nd. Historical Mountain Pine Beetle Activity. [http://www.pfc.cfs.nrcan.gc.ca/entomology/mpb/historical/index\\_e.html](http://www.pfc.cfs.nrcan.gc.ca/entomology/mpb/historical/index_e.html)
- Taylor, S.W. and A.L. Carroll. 2003. Effects of disturbance on Lodgepole pine forest susceptibility to mountain pine beetle infestation in British Columbia. Natural Resources Canada, Canadian Forest Service. Unpublished report, Victoria, BC.

# Optimizing a Monitoring Network for Assessing Ambient Air Quality in the Athabasca Oil Sands Region of Alberta, Canada

Witold Frączek<sup>1)</sup>, Andrzej Bytnerowicz<sup>2)</sup> and Allan Legge<sup>3)</sup>

<sup>1)</sup> ESRI, Application Prototype Lab, Redlands, California, USA

<sup>2)</sup> US Forest Service, Pacific Southwest Research Station, Riverside, California, USA

<sup>3)</sup> Biosphere Solutions, Calgary, Alberta, Canada

To ensure a high level of confidence in the results of any geostatistical interpolation, it is very important to have an adequate number of well distributed air quality sampling stations in a monitoring network. What is the adequate number of sampling stations and what is the best approach to optimize their distribution? Could GIS with a special emphasis on geostatistics help to answer these questions?

## *1. Introduction to geostatistics*

Geostatistics is a discipline of science which applies statistical methods for spatial interpolation. Even though geostatistics was developed independently from geographic information systems (GIS), today it has become an integral part of GIS. The research performed by meteorologists, geologists, foresters, and other scientists can benefit from applying GIS aided by geostatistics.

Geostatistics is applicable when the studied phenomena are the regionalized variables, which fall between random and deterministic variables. Geographic distribution of the regionalized variables cannot be mathematically described as deterministic; yet the distribution of intensity of those phenomena is not random. Most of the natural phenomena that take place in the atmosphere, seawater or soil meet the criteria of this category. Distribution of air temperature, salinity of oceans, soil moisture, and ore deposits concentration in a geologic layer are all examples of regionalized variables. Crop yield prediction and the distribution of air pollutants might also be a subject of geostatistical analysis even if those are not representative of the natural phenomena.

Since we cannot observe the world exhaustively, we must sample. The ultimate criterion for sampling is to obtain an adequate representation of the phenomenon under study. Spatial sampling is an important problem in environmental studies

because the sample configuration influences the reliability of a survey, its effectiveness, and ultimately its cost. Dense sampling (monitoring) networks are expensive but give a precise picture of spatial variability of a given phenomenon. Sparse sampling networks, however, although less expensive, may miss significant spatial features of the studied phenomenon. Good understanding of sampling constraints and other available preexisting information can help to enhance the sampling scheme. Therefore appropriate geostatistical tools should be applied for optimizing monitoring networks, in this case the passive sampler air quality monitoring network located in the Athabasca Oil Sands Region of Alberta, Canada.

One technique used to design an optimal sampling network for a regionalized variable, such as an air quality parameter, is sequential sampling (Goovaerts, 1997; Van Groenigen et al., 1997). Sequential sampling is based on extended knowledge of the area to be sampled and factors controlling the distribution of a regionalized variable. Familiarity with the terrain and various phenomena that could affect an air pollutants concentration and distribution are applied to set an intelligent initial sampling network. The results of this preliminary study are used to densify and optimize the sampling scheme by adding new sampling points in the areas of the lowest reliability of interpolation, highest spatial and temporal variability, and vicinity of the uncertain measurements and at the possible hot spots (maximum concentrations).

The science of geostatistics developed numerous methods of interpolation, out of which kriging is considered to be the most sophisticated and accurate way to determine the intensity of a phenomenon at the unmeasured locations. The application of kriging allows for creation of a continuous layer of information from the set of individual sampling points, called a prediction map. Except for generating an estimated prediction, kriging can provide a measure of an error, or uncertainty of the estimated surface. Since the estimation variances can be mapped, a confidence placed in the estimates can be calculated and their spatial distribution can be presented on a map in order to assist in a decision making process. The prediction standard error maps show a distribution of a square-root of a prediction variance, which is a variation associated with differences between the measured and calculated values. The prediction standard error quantifies an uncertainty of a prediction.

The Geostatistical Analyst, an extension to ArcGIS, a product of the Environmental Systems Research Institute (ESRI), Redlands, California, USA, can be applied to analyze the data from air quality monitoring networks and to generate maps of spatial distribution of the monitored air pollutants and their respective maps of the prediction standard error.

## *2. Environmental concerns related to the rapid growth of oil extraction from the Athabasca Oil Sands*

The Athabasca Oil Sands Region is located in the north-eastern part of the Canadian province of Alberta. The region takes its name from a geologic layer of sands rich in oil that sits over the central part of the Athabasca River basin. Until recently, the boreal forest, a complex ecosystem that comprises a unique mosaic of forest, wetlands and lakes, composed the undisturbed natural habitat. Thousands of buffalos used to roam in and around the region in an area now called Wood Buffalo National Park, which is the largest national park in North America. The First Nations or aboriginal people were enjoying the life style of their choice. The area was only sparsely populated and it was primarily a wilderness outpost of a few hundred people whose main economic activity included fur trapping and trading. Since then, the Town of Fort McMurray has grown from a population of few thousands to about 37,000 in 1996 and 80,000 people in 2006, leaving the community struggling to provide adequate services and housing for those working in the region ([http://environment.gov.ab.ca/info/faqs/faq5-oil\\_sands.asp](http://environment.gov.ab.ca/info/faqs/faq5-oil_sands.asp)).

The Athabasca Oil Sands refers to a large deposit of a naturally occurring viscous mixture of hydrocarbons and sand called bitumen. Historically, bitumen was used by the aboriginal people in the region to waterproof their canoes. The Athabasca oil sands deposits are unique in that some of the oil sands are located very near the surface and can be economically surface mined. About 10% of the Athabasca oil sands are covered by less than 75 meters of overburden, while the underlying oil sands are typically 40 to 60 meters thick and sit on top of the underlying limestone bedrock. The world's first commercial fully integrated oil sands mining and upgrading operation called Great Canadian Oil Sands (now called Suncor Energy Incorporated) began full scale production in the region in 1967, producing 30,000 barrels per day (4,800 m<sup>3</sup>/d) of synthetic crude oil. The second commercial operation, Syncrude Canada Limited, began operating in 1977. Since 2003, as a result of rapid increases in the price of oil, the mining and extraction activities have been greatly expanded and new facilities are being planned - by 2010 oil sands production is projected to reach 2 million barrels per day (320,000 m<sup>3</sup>/d)(<http://www.energy.alberta.ca/OilSands/793.asp>).

Oil sand is made up of a combination of clay, sand and water along with a viscous mixture of hydrocarbons known as bitumen. This bitumen must be heated in order for the oil to flow. Hot water of 50 °C to 80 °C is added to the oil sand to enable

separation of the bitumen (60%), water (30%), and solid material (10%) (Xu, 2002). The process of hydrocarbon extraction from the oil sands requires large amounts of energy. Potential environmental effects of large-scale extraction of crude oil from oil sands are of great environmental concern (<http://thetyee.ca/Views/2007/09/20/TarSands/>). The following provides a brief overview of the extraction and upgrading of bitumen to high quality synthetic crude oil.

One major step in extracting bitumen from oil sand is called conditioning. In this step, large lumps of oil sand are broken up and coarse material is removed. After the oil sand is crushed, it is mixed with warm water and then moved by pipeline to the extraction plant ([http://www.oilsandsdiscovery.com/oil\\_sands\\_story/pdfs/extraction.pdf](http://www.oilsandsdiscovery.com/oil_sands_story/pdfs/extraction.pdf)). The water used in the extraction process is discharged into tailings ponds, which are the settling basins. The water contains a mixture of sands, clays and fine silts that can take decades to settle out of the water. The tailing ponds in this area cover 50 km<sup>2</sup> (Fig. 1, [http://www.oilsandsdiscovery.com/oil\\_sands\\_story/pdfs/enviro\\_protection.pdf](http://www.oilsandsdiscovery.com/oil_sands_story/pdfs/enviro_protection.pdf)).

Another major step is upgrading the process that changes bitumen into synthetic crude oil. Bitumen, like crude oil, is a very complex mixture of chemicals (hydrocarbon chains in excess of 2,000 molecules). Some upgrading processes remove



*Fig. 1: Aerial view of the Athabasca Oil Sands area with visible air pollution emissions from the Suncor Oil Sands Plant (May 2005). Brown horizontal haze in the background is caused by emissions from the Syncrude Oil Sands Plant main stack. The Athabasca River crosses the landscape while the water body in front of the Suncor Oil Sands Plant is a tailings pond (Photo courtesy Andrzej Bytnerowicz).*



carbon, while others add hydrogen or change molecular structures. Upgrading also involves sorting bitumen into its component parts and then using them to produce a range of additional products and byproducts. The main product of upgrading is the synthetic crude oil that can be later refined like conventional crude oil into a range of consumer products ([http://www.oilsandsdiscovery.com/oil\\_sands\\_story/pdfs/upgrading.pdf](http://www.oilsandsdiscovery.com/oil_sands_story/pdfs/upgrading.pdf)).

The major sources of air pollutants in the Athabasca Oil Sands Region are the emissions associated with the processes of mining, extracting and upgrading of bitumen and transforming the bitumen into a high quality synthetic crude oil.

The Wood Buffalo Environmental Association (WBEA) is responsible for the ambient air monitoring in this area using both continuous monitors and passive samplers. Continuous ambient air quality measurements are made in a network of 14 monitoring stations in the core area of the Athabasca Oil Sands for air contaminants such as hydrogen sulfide ( $H_2S$ ), total reduced sulfur (TRS), sulfur dioxide ( $SO_2$ ), nitrogen oxides ( $NO$  and  $NO_2$ ), carbon monoxide ( $CO$ ), ozone ( $O_3$ ), total hydrocarbon (THC) and particulate matter measured as,  $PM_{2.5}$  and  $PM_{10}$  ([http://www.oilsandsdiscovery.com/oil\\_sands\\_story/pdfs/enviro\\_protection.pdf](http://www.oilsandsdiscovery.com/oil_sands_story/pdfs/enviro_protection.pdf)).

A network of passive samplers was established for monitoring integrated, month-long, concentrations of the selected pollutants and consists of the sites collocated with the continuous ambient air quality monitoring stations and additional 11 remote forest health assessment sites. Maxxam passive samplers (Tang, 2001) are used for monitoring concentrations of  $NO_2$ ,  $SO_2$  and  $O_3$ . Passive samplers of the US Forest Service design (Bytnerowicz et al., 2006) are used for monitoring nitric acid vapor ( $HNO_3$ ) while the passive samplers of the Ogawa design are used for  $NH_3$  monitoring (Roadman et al., 2003).

The objective of this paper is to illustrate how geostatistical analysis can be applied to find the optimal locations for passive samplers to be added to the existing network in order to gain a better understanding of the spatial distribution of air pollutants in the Athabasca Oil Sands Region. This is done using as an example the data from the passive sampler network monitoring for  $HNO_3$  and  $NH_3$ .

### *3. Practical limitations to optimize the ambient air quality monitoring network*

The study area is considered to be the region that is directly affected by the air pollution emitted as a result of oil sand mining, extraction and upgrading in the Athabasca Oil Sands Region. This region might be referred as an airshed. At this point, however, there is no clear picture as to the distance and direction that air

pollutants originating in the region might extend. Further studies are needed to more accurately determine the size of the area needed for air quality monitoring. However, at this point, a rough assessment of the size of the area that needs to be monitored is in a range of 90,000 to 120,000 km<sup>2</sup>.

The Athabasca Oil Sands Region is connected with the rest of the world with only one major road. Within the region there are very few roads and some are only assessable during the winter months. The lack of adequate transportation infrastructure has been caused by the fact that until the recent oil boom, the area was very sparsely populated and because the natural conditions (harsh climate, widespread wetlands) are not favorable for building a denser road network. This has caused a major logistical and fiscal challenge to developing and maintaining an air quality monitoring network.

The rapidly growing rate of oil recovery and processing, as well as the expansion of the resource exploitation area have increased the emissions of air pollutants. Consequently, there has been a growing concern that ambient concentrations of air pollutants could increase to levels which have the potential to be unhealthy to people and forest ecosystems. This concern has resulted in a need for more extensive monitoring of key air pollutants such as NO<sub>2</sub>, SO<sub>2</sub>, HNO<sub>3</sub>, NH<sub>3</sub> and O<sub>3</sub> that can potentially cause damage to forest ecosystems. Nitric acid and NH<sub>3</sub> are also important components of the atmospheric dry nitrogen deposition with potentially negative effect on forests and other ecosystems (Bytnerowicz et al., 1998). In this area, especially lichens, Jack pine, trembling aspen and acid sensitive soils are potentially affected by air pollution.

The continuous air quality monitoring stations in the region are located within a close proximity to the main road going through the core of the bitumen mining, extraction and upgrading area and connecting the two major population centers of the area, Fort McMurray and Fort McKay. Remote forest monitoring sites which are away from the main road have to be accessed from the air by helicopter. For the monitoring seasons of 2005 and 2006, HNO<sub>3</sub> and NH<sub>3</sub> passive samplers were operational in 23 locations since May 2005. Nine additional passive sampling stations were added in 2007 and 2008 in remote forested areas which enhanced the monitoring network and the total number of stations has reached 32 (Fig. 2). The passive samplers were changed every month in the summer and every two months in the winter.

The geographic extent of the Athabasca Oil Sands Region is large and roughly defined as 40,000 km<sup>2</sup> ([http://www.oilsandsdiscovery.com/oil\\_sands\\_story/pdfs/](http://www.oilsandsdiscovery.com/oil_sands_story/pdfs/)

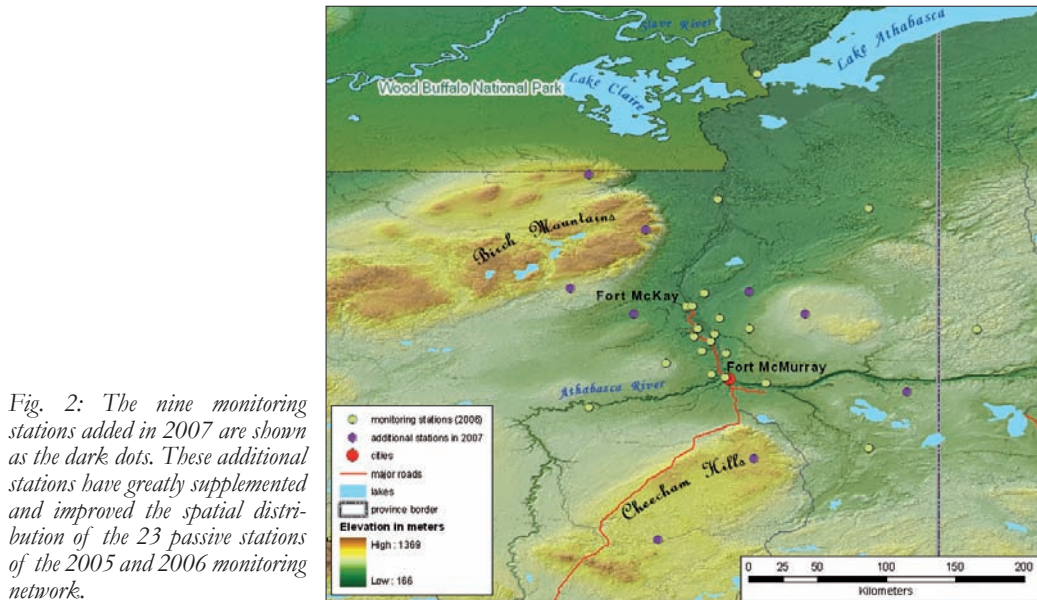
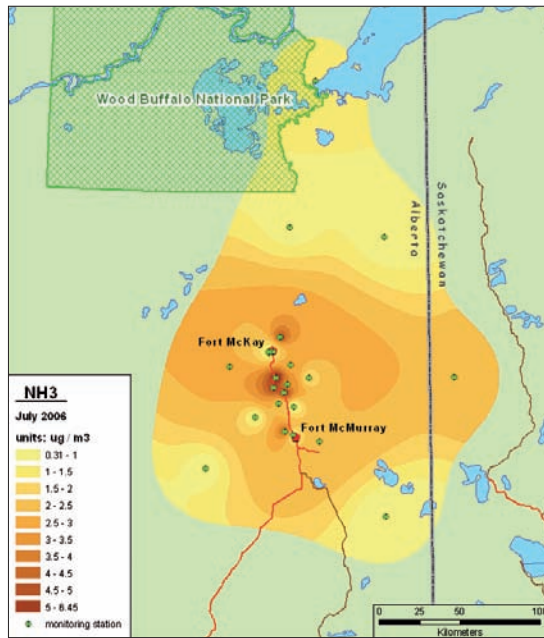

Fig. 2: The nine monitoring stations added in 2007 are shown as the dark dots. These additional stations have greatly supplemented and improved the spatial distribution of the 23 passive stations of the 2005 and 2006 monitoring network.

vastresource.pdf). The boreal forest ecosystem that endures most of the disadvantages of the intense oil extraction is obviously not limited to the spatial extent of the mining activities or the relevant oil sands geologic layer. None of the geographic or administrative divisions is in any way associated with the area over which the plumes of air pollution caused by activities related to oil extraction processes may result in damage to the environment. This constitutes the technical problem for the GIS/geostatistical analysis since the extent of the study area can not be defined other than arbitrarily.

#### 4. Challenge to perform the geostatistical analysis in the Athabasca Oil Sands Region

Based upon results from the passive sampler monitoring network for the years 2005, 2006, and 2007, high spatial and temporal variations in concentration of the air pollutants measured have been observed. Despite the fact that the monthly passive monitoring period integrates and smooths real-time concentrations of air pollutants, large differences in the concentration of the pollutants between some of the adjacent stations have been observed (Fig. 3). Similarly, a passive monitoring station that indicated high mean concentration during one monitoring period could show lower mean concentration during the very next monitoring period.



*Fig. 3: Spatial distribution of NH<sub>3</sub> in July of 2006 determined from 23 passive samplers. This is an example of a characteristic strong spatial variation of NH<sub>3</sub> across the landscape. Many neighboring stations recorded very different concentrations of NH<sub>3</sub>.*

Industrial activities related to the oil extraction and upgrading as well as emissions from trucks and other heavy equipment in the area are considered the main causes of the observed elevated concentrations of the air pollutants monitored. However, other causes have to be taken into account as well. Changing wind directions could be one of the causes of the observed high spatial variability of HNO<sub>3</sub> and NH<sub>3</sub> concentrations. During the summer months, prevailing winds come most frequently from the west (combined W, NW, and SW winds stand for 50.2% in July and 53.8% in August, of all winds).

Forest fires are a natural occurring phenomenon in the boreal forests. Frequently, however, such fires are hard to control and can last until summer rain storms extinguish them. While the passive sampling network is mostly designed to monitor air pollution caused by the activities related to the oil extraction and processing, the frequently occurring summer forest fires may have a strong influence on the results obtained. Forest fires can generate high concentrations of HNO<sub>3</sub> during their flaming phase and elevated concentrations of NH<sub>3</sub> at their smoldering phase. Getting forest fire data including location and the duration of fires and estimates of NO<sub>x</sub> emissions from fires and other sources is needed to better understand causes of the elevated levels of the measured pollutants (Fig. 4).

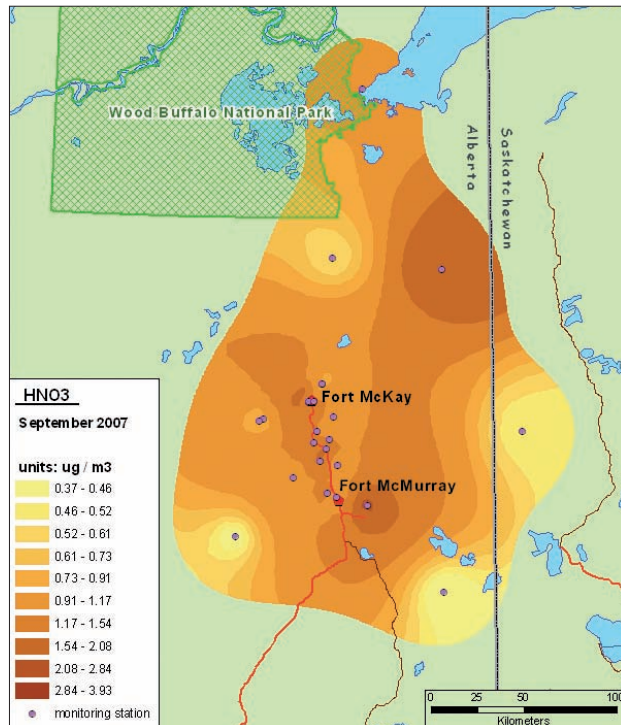

Fig. 4: Spatial distribution of HNO<sub>3</sub> in September 2007. The monitoring station located at the north eastern site recorded the highest concentration of HNO<sub>3</sub> which could be potentially caused by a local forest fire.

### 5. Initial results of the geostatistical analysis of air pollution in 2007

On all of the figures shown, which are just the graphic examples of a general pattern, the neighboring passive monitoring stations often show very strong differences in the recorded monthly average concentrations of pollutants. For most of the monthly monitoring periods, the spatial distribution of all monitored air pollutants seemed to be random. Moreover, the temporal distribution of the air pollutants monitored indicates that there was no steady pattern of high and low concentration at the same locations (Fig. 5).

Not only it is hard to find the spatial or temporal trends in the distribution of particular air pollutants, but also there is no correlation between concentrations of HNO<sub>3</sub> and NH<sub>3</sub> at many locations and time periods (Fig. 6). This is not surprising considering that the origin of two pollutants is different.

These large variations seem to be typical for the area despite the fact that the Athabasca Oil Sands Region is relatively flat and that wind patterns are relatively stable. Such strong variations and the apparent randomness in the distribution of

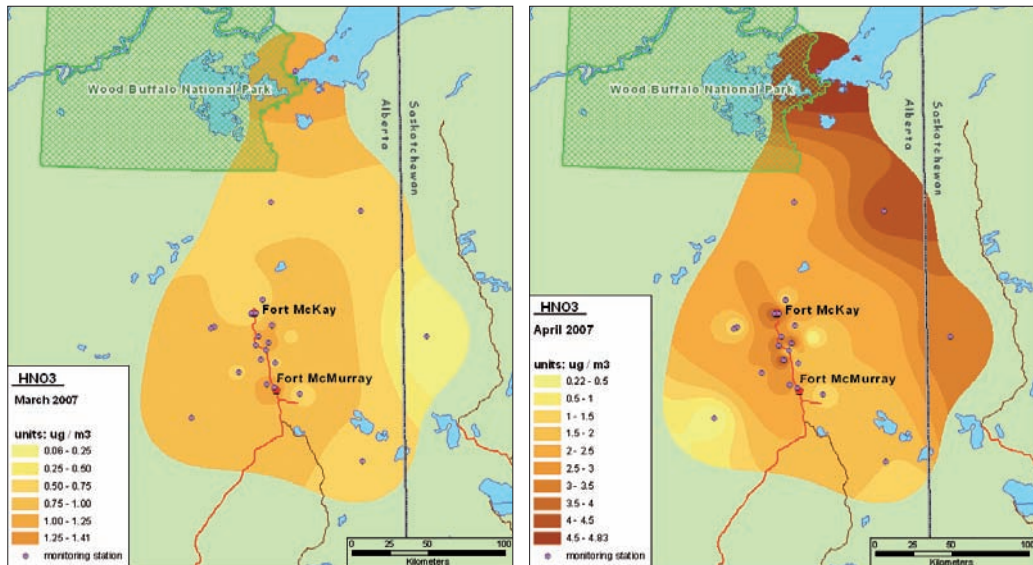

Fig. 5: Large variation in the concentrations of air pollutants in space and time is characteristic for the Athabasca Oil Sands region. On the left, the passive sampling network indicated that in March 2007, the highest concentrations of  $\text{HNO}_3$  occurred around Fort McMurray, while the lowest on the Saskatchewan site of the study area. One month later, the distribution of  $\text{HNO}_3$  changed considerably with the highest concentration of  $\text{HNO}_3$  on the north and east (the right picture). Additionally, the maximum concentrations in April were about four times higher than in March.

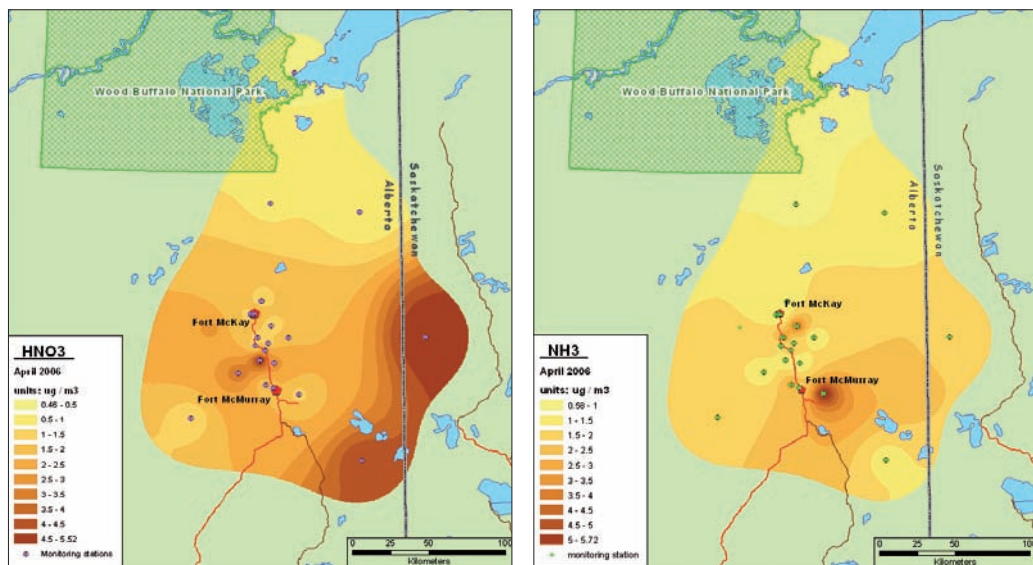

Fig. 6: Spatial distributions of  $\text{NH}_3$  and  $\text{HNO}_3$  are not correlated with each other for most of the monthly monitoring periods. This can be seen in the randomly selected example of April 2006.

air pollution make it very hard to perform the geostatistical analysis on the results from a monitoring network consisting of an insufficient number of monitoring stations. Having the monitoring network expanded by adding additional sampling locations could contribute to the elimination of potential outliers, to finding trends and patterns, and consequently result in a more accurate prediction of the spatial concentration distribution of each of the air pollutants monitored. The denser network, with more numerous air quality monitoring sites may also help to better demonstrate contribution of the point sources, including potential new ones, to the overall distribution of air pollution concentrations in the studied area.

#### *6. Preliminary analysis of the extent of the area that could be trustworthily predicted for the growing monitoring network*

The geostatistical method of kriging has an option to generate a map of the standard error of prediction that can be interpreted as the layers of confidence of the relevant prediction map. An example of such a map is shown on Fig. 7, where the relative zones of confidence are shown in the shades of yellow (high confidence), orange, and brown (low confidence). The map of the prediction confidence (also known as the prediction standard error map) has been clipped along the outline of the darkest zone, which happened to be the eighth one. The spatial clipping was performed to emphasize that beyond that zone, the relevant prediction map does not have much of a chance of accurately estimating the pollutant concentration. What level of confidence should be considered as trustworthy may depend on the project, the significance of decisions that might be taken based on the prediction map, the required accuracy, and the cartographic scale of the monitoring network.

While generating geostatistical surfaces of the concentration prediction of any air pollutant, it is necessary to be aware that such surfaces are only estimations and that their trustworthiness depends on the number of sampling points, their distribution, and the measured values. Since especially the extreme values may influence the surface of trustworthiness, each monitored period and each pollutant may have their individual distribution of prediction confidence, thus a prediction standard error map may have to be generated for it individually.

A map of the prediction standard error (Fig. 7) was created based on the network of 23 monitoring stations operating in 2006. Next year, in 2007, nine new stations were added to the network. These new stations enhanced the trustworthiness of predictions generated on the enlarged monitoring network of 32 stations. Due to the distribution of the newly added stations vs. the previously existing stations, the

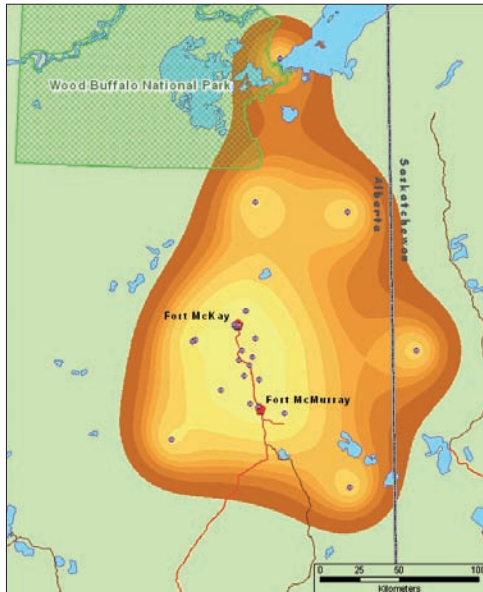

Fig. 7: The geostatistical method of simple kriging was applied to create the map of the standard error of prediction for the network of 23 monitoring stations that operated in the 2005 and 2006 seasons.

spatial enhancement in trustworthiness has been accomplished by expanding the area of confidence. Moreover, with the nine new stations, each individual layer of confidence inflated its size. Note that on the map of prediction standard error for the monitoring network of 2007, the threshold of confidence was clipped along the outline of the seventh (instead of the eighth) relative zone of confidence (Fig. 8).

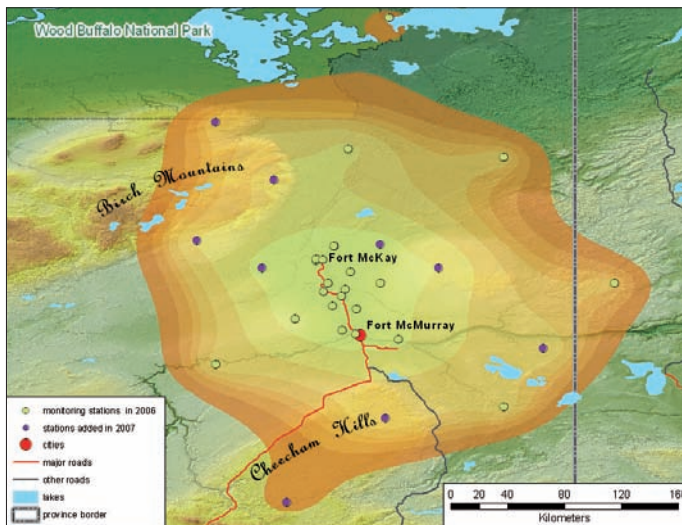
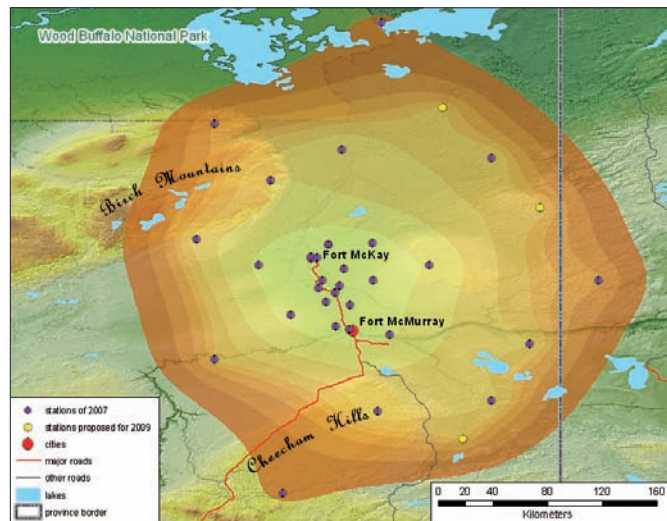

Fig. 8: The area where the prediction of HNO<sub>3</sub> based on the network of 32 passive monitoring stations as of 2007 could reach the acceptable level of confidence.



From the point of view of the geostatistical reliability of the created prediction, the monitoring network of 32 points should generally be considered insufficient. Besides, for the area that in the past monitoring seasons was characterized by very strong spatial variation of the  $\text{HNO}_3$  and  $\text{NH}_3$  concentrations, while the condition of stationarity was not frequently fulfilled, the number of monitoring stations should be significantly higher than 32. At this juncture, it is desirable and feasible to supplement the existing monitoring network with an additional 3 stations, so in 2009 the monitoring network of 35 stations could operate.

How does one locate these new stations so the resources are most effectively used and the overall quality of the passive air quality monitoring network is enhanced the most? One way of approaching the problem would be to analyze the map of the prediction standard error and to locate the proposed new stations at the edges of the zone of the acceptable confidence of prediction. For this study, the wind direction should be considered. Since the prevailing winds are blowing from the W, NW, and SW, the plumes of gaseous emissions typically travel to the E, SE and NE. Consequently, in order to observe the impact of the pollutants on the local vegetation, the three proposed stations should be located as shown on Fig. 9. A simulation of the prediction standard error has been performed and the results of the further expanded zones of confidence are presented in Fig. 9. Since at this point, the proposed locations of the three supplemental stations and the relevant simulation are only a preliminary assessment, the location of each one of the new stations is approximate. New stations could be positioned within a radius of about 10 km from



*Fig. 9: A simulation of the expansion of the area of the acceptable level of confidence with the proposed three additional stations. The total extent of the zone of acceptable confidence has moved eastward.*

the location indicated on Fig. 9, depending on the local situation, accessibility of the site, as well as the vegetation and the nearby topography.

### *7. Conclusions and final remarks*

For reliable and consistent monitoring of air pollutants concentrations in an area as complex as the Athabasca Oil Sands Region, more passive sampling stations should be added to the network of 32 stations operating in 2008. As the future optimized network will have to respond to the additional new sources of emissions, the approach to the network design has to be flexible. It is imperative to account for a dynamic expansion of the resource exploitation area and for the potentially migrating locations of the primary mining and the oil sand extraction and upgrading activities.

Further studies are required to provide more accurate maps of the standard error of prediction and the models of the levels of confidence in the prediction. The maps of the standard error of prediction presented in this paper show the relative levels of confidence, while the value of the theoretical standard error should be interpreted as the potential maximum error of prediction. The values of the standard error of prediction are essentially unitless. An effort should be made to provide maps of the potential standard error expressed in percentages. Such maps would be crucial for locating the additional points of the passive monitoring network according to the method of network design referred to as sequential sampling. With this method, for enhancing the existing networks it is imperative to locate the new points in such a way that their influence on the reliability of the entire network would not only be positive but also optimal. In every step of the sequential network improvement, the most advantageous locations for the new monitoring stations need to be taken from the points of view of the geostatistical theorem and the practical feasibility. These efforts can readily be translated into improved cost effectiveness. In other words, this approach can achieve the biggest increase in the reliability of the entire monitoring network from the minimal number of additional passive air quality monitoring stations.

More complete information on forest fires, their location and duration should be analyzed together with the data from the monitoring network. Collateral analysis of meteorological data (precipitation, winds, temperature) from as many weather stations as possible may help to improve the accuracy of prediction.

Properly performed geostatistical modeling is needed for optimization of the monitoring activities resulting in acceptable reliability of data for understanding air pollution hazards and cost saving. More research is necessary to address the challenges of assessing the impact of air pollution on the natural landscape of the Athabasca Oil Sands Region.

Geostatistical Analyst, an extension to ArcGIS proved to be the versatile software for development of spatial models of air pollutants distribution and surfaces of uncertainty of prediction. This geostatistical software may allow creating simulated monitoring networks. Such simulations are very effective in designing optimal networks for monitoring air quality in the Athabasca Oil Sands Region.

### *Acknowledgements:*

The study was sponsored by the Wood Buffalo Environmental Association, Fort McMurray, Alberta, Canada. The authors thank Ted Sutton, Carna MacEachern, and David Spink for their continuous support of this study, Cynthia Huppie for assistance with field monitoring activities, Diane Alexander for coordinating chemical analyses of passive samplers, and Susan Schilling for data processing.

### *References:*

- <http://www.energy.alberta.ca/OilSands/793.asp>  
[http://www.oilsandsdiscovery.com/oil\\_sands\\_story/story.html](http://www.oilsandsdiscovery.com/oil_sands_story/story.html)  
<http://tothetarsands.ca/2007/09/24/tailings-ponds/>  
<http://theyee.ca/Views/2007/09/20/TarSands/>  
[http://environment.gov.ab.ca/info/faqs/faq5-oil\\_sands.asp](http://environment.gov.ab.ca/info/faqs/faq5-oil_sands.asp)  
<http://www.sprol.com/?p=80>  
[http://www.greencarcongress.com/2007/05/study\\_oil\\_sands.html](http://www.greencarcongress.com/2007/05/study_oil_sands.html)  
[http://www.swstechnology.com/pdfs/case\\_studies/syncrude\\_canada.pdf](http://www.swstechnology.com/pdfs/case_studies/syncrude_canada.pdf)
- Arbaugh, M. J., Miller, P. R., Carroll, J. J., Takemoto, B., Procter, T. 1998. Relationship of ambient ozone with injury to pines in the Sierra Nevada and San Bernardino mountains in California, USA. *Environmental Pollution*, 101, 291-301.
- Bytnerowicz, A., Dueck, T., Godzik, S. (1998). Nitric oxide, nitrogen dioxide, nitric acid vapor and ammonia. In: R. Flagler (ed.) *Recognition of Air Pollution Injury to Vegetation: a Pictorial Atlas*, Air & Waste Management Association, Pittsburgh, PA, 5-1 through 5-17

## Global Change and Sustainable Development in Mountain Regions

- Bytnerowicz, A., Sanz, M. J. Arbaugh, M. J. Padgett, P. E. Jones, D. P. Davila, A. 2005. Passive sampler for monitoring ambient nitric acid ( $\text{HNO}_3$ ) and nitrous acid ( $\text{HNO}_2$ ) concentrations. *Atmospheric Environment*, 39, 2655-2660.
- ESRI – White Paper. 2001. ArcGIS Geostatistical Analyst: Statistical Tools for Data Exploration, Modeling, and Advanced Surface Generation.
- Frączek, W., Bytnerowicz, A., Arbaugh, M. 2003. Use of geostatistics to estimate surface ozone patterns. In: A. Bytnerowicz, M. Arbaugh and R. Alonso (eds) *Ozone Air Pollution in the Sierra Nevada: Distribution and Effects on Forests*. Elsevier, Amsterdam, p. 215- 247.
- Gertler, A. W., Bytnerowicz, A., Cahill, T. A., Arbaugh, M., Cliff, S., Kahyaoglu-Koracin, J., Tarnay, L., Alonso, R., Frączek, W. 2006. Local air pollutants threaten Lake Tahoe's clarity. *California Agriculture*, 60, No. 2, 53-58.
- Goldman, C. R. 2006. Science a decisive factor in restoring Tahoe clarity. *California Agriculture*, 60, No. 2, 45-46.
- Goovaerts, P. 1997. *Geostatistics for Natural Resources Evaluation*, Oxford University Press, Oxford, Applied Geostatistical Series, 483 pp.
- Gu, G., Xu, Z., Nandakumar, K., Masliyah, J.H., 2002, Influence of water-soluble and water-insoluble natural surface active components on the stability of water-in-toluene-diluted bitumen emulsion, *Fuel*, 81, pages 1859–1869.
- Krupa, S. V., Tonnejck, A. E. G., Manning, W. J. 1988. Ozone: In: Flagler, R. B. (ed.) *Recognition of Air Pollution Injury to Vegetation*. Air and Waste Management Association, p. 2-1 through 2-28.
- Roadman, M. J., Scudlark, J. R., Meisinger, J. J., Ullmann, W. J. 2003. Validation of Ogawa passive samplers for the determination of gaseous ammonia concentrations in agricultural settings. *Atmospheric Environment*, 37, 2317-2325.
- Van Groenigen, J.W. and Stein, A., Zuurbier, R. 1997. Optimization of Environmental Sampling Using Interactive GIS”, *Soil Technology* 10, pp. 83-97.

# The New Era has Begun: Renewable Bioenergy Production as a Progressing Interdisciplinary Research Approach

Yolina Hubenova<sup>1</sup>, Mario Mitov<sup>2,3</sup>

- 1) Department of Biochemistry and Microbiology, "Paisii Hilendarski" University, Plovdiv, Bulgaria
- 2) Department of Chemistry, South-West University "Neofit Rilsky", Blagoevgrad, Bulgaria
- 3) Institute of Electrochemistry and Energy Systems – Bulgarian Academy of Sciences, Sofia, Bulgaria

The aim of this study is a verification of possibilities for introducing budding yeast cells as a microreactor into biofuel cells. The investigation includes optimization of conditions for high efficiency utilization of in vivo produced electrons within the main biochemical pathways, which naturally cover the energy needs of the living cells. We trace out the three stages of cellular respiration - glycolysis, citric acid cycle and oxidative phosphorylation in eukaryotic cells, aspiring to shuttle the electrons between the biological system and the fuel cell anode by using appropriate mediator. The challenge is to use the biological energy from subcellular level. We modulate the biofuel cell/cell suspension elements in such manner that the mediator could capture the electrons from the biological electron transport chains and transfer them subsequently through the double mitochondrial membrane and outer membrane of intact cells and/or from cytosol under anaerobic conditions and finally, to the electrode, where they are transmuted into electricity.

## *Introduction*

One of the greatest challenges at the onset of the 21<sup>st</sup> century is to solve the problem of permanently increasing energy consumption. On the one hand, because of the progressively enlarging population on our planet and the rapidly developing technical progress as well as regardless of consequences the constant exhaustion of the natural fuel resources. On the other hand, the use of traditional carbon-containing fuels aimed at satisfying energy needs today has led to a hazardous increase of the environmental pollution and climate changes. In this regard, the application of ecologically friendly energy sources and innovative converters has turned into one

of the most urgent and primary tasks of our time. This includes research, development and demonstrations (European Commission C 5765, 2007) aiming to:

- Improve energy efficiency throughout the energy system taking into account the global environmental performance;
- Accelerate the penetration of renewable energy sources;
- Decarbonise power generation and, in the longer term, substantially decarbonise transport;
- Reduce greenhouse gas emissions;
- Diversify Europe's energy mix;
- Enhance the competitiveness of European industry.

From all developed up-to-now energy converters, hydrogen fuel cells possess the highest efficiency, reaching up to 85%, when the electric and the heat energy are co-generated. The production and application of the different fuel cells types is still quite limited, mainly due to the high price of hydrogen production and storage and to the use of expensive catalysts. However, in the next 10-15 years fuel cells are expected to replace a big share of the currently used energy converters, not only in the transport and mobile applications, but also in the stationary ones.

As alternative to the conventional fuel cells we are looking for new ways for sustainable energy production combining the biotechnological principles with those of electrochemistry. Biofuel cells are a perspective approach for overcoming both the dramatically increasing energy demands and the irreversible environmental pollution caused by the use of non-renewable carbon-based fuel resources. In addition, biofuel cells potentially offer solutions to the trend towards miniaturization and portability of computing, communications as well as implantable electrically operated devices.

The use of entire microorganisms as microreactors in fuel cells eliminates the need for isolation of individual enzymes and allows the active biomaterials to work under conditions close to their natural environment, thus at high efficiency. Microorganisms have the ability to produce electrochemically active substances that may be metabolic intermediates or final products of anaerobic respiration.

The most investigations up-to-now include the usage of prokaryotes as a proton/electron source. Those are hydrogen gas producing bacteria (Das and Veziroglu, 2001), (Maness and Weaver, 2001), bacteria, which generate fuels such as methane (Kim et al., 2002), ethanol, methanol (Kosaric and Velikonja, 1995) from waste products, sulphate reducing bacteria (Cooney et al., 1996), etc.

The aim of this study is a verification of possibilities for introducing budding yeast cells (eukaryotes) as a microreactor into biofuel cells. The investigation includes biochemical and electrochemical studies of conditions for high efficiency utilization of *in vivo* produced electrons within the main biochemical pathways, which naturally cover the energy needs of the living cells.

### Experimental

In this *ab initio* study, the log-phase of growth during *Saccharomyces cerevisiae* yeast cell cycle was examined under aerobic as well as anaerobic conditions. Different amounts of yeast were cultivated in suspension media containing carbohydrates and phosphate buffer pH 7. The assimilation levels of monosaccharide glucose and disaccharide sucrose in the yeast medium were quantified by 3,5-dinitrosalicylic acid (DNS) colorimetric method (Kozłowska et al., 2007). In parallel, the quantity of the inorganic phosphate converted into organic one in the progress of cell cycle was analyzed by means of Molybdenum blue phosphorous method (He and Honeycutt, 2005). The values of glucose and phosphate concentration in the cell suspensions were determined by standard calibration curves methods.

Electrochemical experiments were performed in a model two-compartment cell. Suspension of 0.1 g/ml yeast, 0.25 mol/l glucose or sucrose, methylene blue as an electron mediator and phosphate buffer was used as an anolyte. The suitable pH of buffer solution was verified as described by Benetto (1990). The neutral pH choice was considered as an optimal value for the cell growth. Solution of 0.1 mol/l  $K_3[Fe(CN)_6]$  or  $NH_4VO_3$  in phosphate buffer (pH7) was used as a catholyte. For accomplishment of a galvanic cell both solutions were poured into separate closed vessels connected with a salt bridge. Segmented graphite rods were used as electrodes.

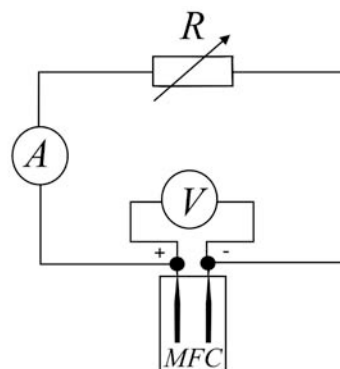

Fig.1: Circuit diagram for realization of polarization measurements: MFC – model fuel cell, R – variable resistor, A – ammeter, V – voltmeter.

Polarization characteristics were achieved by realization of electric scheme, drawn in Fig. 1. Varying the resistance  $R$  values, pairs of voltage and current were recorded and the corresponding volt-ampere as well as power curves were plotted. Discharge curves at constant ohmic resistance were also monitored.

### *Results and discussion*

The three stages of cellular respiration - glycolysis, citric acid cycle and oxidative phosphorylation in eukaryotic cells, were traced out in the present study, aspiring to shuttle the electrons between the biological system and the fuel cell anode by using appropriate mediator. Conditions for optimal electron harvest during the cell cycle development of *Saccharomyces cerevisiae* were searching for. To realize that, the biofuel cell/medium elements should have been modulated in such manner that the used mediator could capture the electrons from the biological electron transport chains and transfer them subsequently throughout the double mitochondrial membrane, cytosol and outer membrane of intact cells and finally, to the electrode. The results from quantitative analyses, showing the progress of yeast cell development, are summarized in Table 1.

*Table 1: Quantitative determination of glucose and inorganic phosphate by DNS and Molybdenum blue phosphorous methods during yeast cultivation.*

Yeast suspension	0.1 g/ml yeast + 250 mM glucose/ 67 mM phosphate buffer, pH 7				0.1 g/ml yeast + 250 mM sucrose/ 67 mM phosphate buffer, pH 7			
	aerobic		anaerobic		aerobic		anaerobic	
Conditions	glucose	PO <sub>4</sub> <sup>3-</sup>	glucose	PO <sub>4</sub> <sup>3-</sup>	glucose	PO <sub>4</sub> <sup>3-</sup>	glucose	PO <sub>4</sub> <sup>3-</sup>
Incubation time (at 30°C), minutes	mM	mM	mM	mM	mM	mM	mM	mM
20	11	48	9	20	40	20	39	21
30	9	20	8	19	40	16	34	15
40	5	19	7	19	40	16	32	15

The time limit, during which enough adenosine 5'-triphosphate (ATP) amount had been synthesized without inhibiting effect for the glycolysis regulation enzymes, was determined. In such manner, we indirectly proved the stage of further running of processes involved in Krebs cycle and the conversion of the inorganic phosphate into ATP as well as the transfer of electrons by the electron-carriers nicotinamide-adenine-dinucleotide (NAD) and flavine-adenine-dinucleotide (FAD) into respi-



ratory chains under aerobic conditions. The same analysis was made under anaerobic conditions, by which carbohydrates metabolize to ethanol. In general, this is of importance for the fuel cell application because if oxygen is present then it will collect the electrons as it has a greater electronegativity than the mediator.

Under aerobic conditions, the oxidation of glucose in the examined yeast strain runs more intensively than the further pyruvate transmutation in citric acid cycle and oxidative phosphorylation. In a contrast, the glycolysis and the processes of formation of ATP obviously take place with similar rates even at the first 20 minutes under anaerobic conditions.

The rate of phosphate assimilation was also verified by adding disaccharide into the yeast suspension. Due to sucrose hydrolysis and participation of fructose in the cell catabolism identical quantity of phosphate under both aerobic and anaerobic conditions was determined at the end of the first generation time.

The iso-osmotic conditions for cell culture development were chosen for running of electrochemical assays. Typical polarization voltage-current dependences and the corresponding power curves, obtained with the model biofuel cell by using *Saccharomyces cerevisiae* budding yeast, are presented in Fig. 2.

Both polarization characteristics and power curves are comparable with those reported for other types of microorganisms (prokaryotes) in literature (Bullen et al., 2006). The open circuit voltage exceeds 500 mV and the output power tends to 15  $\mu$ W. These results demonstrate the operational principles of biofuel cells utilizing yeast and could be used as a base for further investigations.

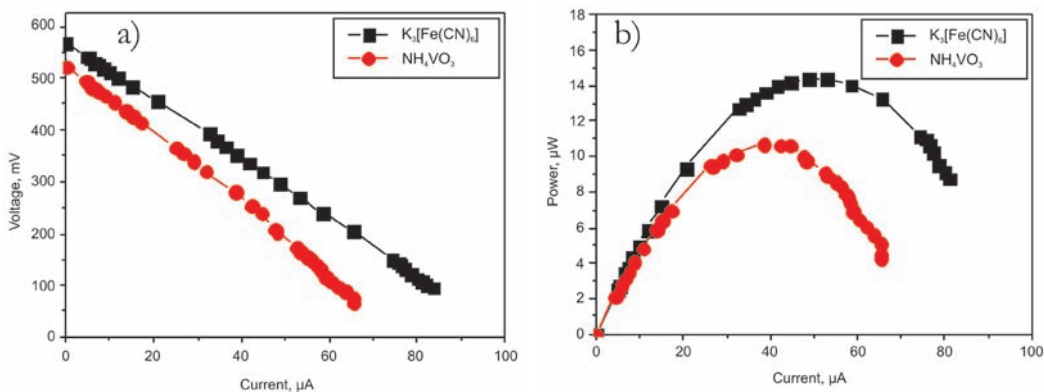

Fig. 2: a) Polarization characteristics and b) power curves obtained with 0.1 g/ml yeast + 250 mM glucose/67 mM phosphate buffer, pH 7 as an anolyte and 100 mM  $K_3[Fe(CN)_6]$  or  $NH_4VO_3$ /67 mM phosphate buffer, pH 7 as a catholyte.

As seen from Fig. 2, at equal other conditions better performance was observed with  $K_3[Fe(CN)_6]$  in comparison with ammonium vanadate solution as a catholyte. By this reason, the potassium ferricyanide solution was further used in the subsequent experiments.

Discharge of the model biofuel cell at a constant resistance equal to this, at which maximum power had been obtained, was also carried out. Resulting curves, presenting the change of generated current within time, are plotted in Fig. 3. The electrooxidation of carbohydrates (glucose or sucrose) without yeast suspension has been monitored as control test (blank) and the corresponding discharge curves are also shown in Fig. 3.

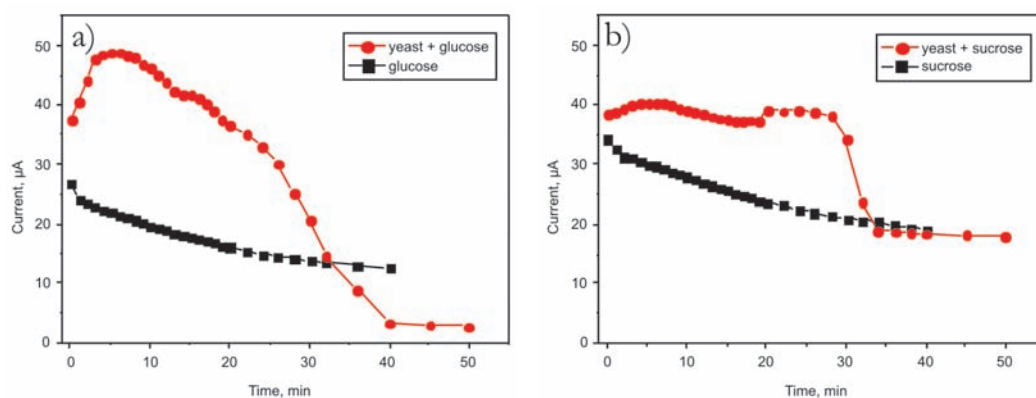

Fig. 3. Current vs. time curves obtained at constant ohmic resistance ( $1000 \Omega$ ) by using: a) glucose; b) sucrose as a substrate.

As expected, most intensive current generation was observed during the log-phase growth of yeast cells, determined by biochemical analysis. Probably, the slower assimilation of sucrose, used as a carbohydrate source, leads to more uniform levels of generated current. However, after 30 minutes the current values significantly decrease and become comparable and even lower than those obtained with pure substrates. The obtained results indicate that the generated electricity is mainly due to the electrons gained from the biological electron-carriers in the processes of glycolysis and anaerobic respiration. For comparison, values of current and cell voltage obtained with yeast-carbohydrate suspension as well as carbohydrate solutions without yeast are summarized in Table 2. The calculated differences between measured values are presented in separate columns.

Table 2: Experimental values of current and cell voltage. (Sg-Bg – calculated differences between Sample glucose and Blank glucose data; Ss-Bs – calculated differences between Sample sucrose and Blank sucrose data).

	Blank glucose				Sample glucose				Sg-Bg				Blank sucrose				Sample sucrose				Ss-Bs							
Anolyte content	250 mM glucose/ 67 mM PO <sub>4</sub> <sup>3-</sup>				10g yeast + 250 mM glucose/ 67 mM PO <sub>4</sub> <sup>3-</sup>								250 mM sucrose/ 67 mM PO <sub>4</sub> <sup>3-</sup>				10g yeast + 250 mM sucrose/ 67 mM PO <sub>4</sub> <sup>3-</sup>											
Time, minutes	0	20	30	40	0	20	30	40	0	20	30	40	0	20	30	40	0	20	30	40	0	20	30	40	0	20	30	40
Current, $\mu$ A	26,9	16,1	13,9	12,6	37,4	37,6	20,5	2,1	10,5	21,5	6,6	-10,5	34,2	23,6	21,0	19,1	38,4	39,2	34,3	18,6	4,2	15,6	13,3	-0,5				
Voltage, mV	40	23	20	18	57	57	30	2	17	34	10	-16	51	35	31	28	58	59	52	27	7	24	21	-1				

The electrochemical characteristics proved that at least 250 mM monosaccharide have to be present into the primary yeast cell suspension because the current values decrease significantly after the glucose amount falls down up to approximately 5 mM at the 40<sup>th</sup> minute (*see* Table 1).

### Conclusions

The results from this investigation confirm the possibility for electricity generation by using *Saccharomyces cerevisiae* budding yeast as a microreactor into biofuel cells. Although the values of generated current and power are relatively low, they demonstrate the basic principle of how our model fuel cell converts the *in vivo* produced electrons into electricity.

Further interdisciplinary cooperation between researchers in biochemistry, microbiology, electrochemistry and engineering is required for optimisation of microorganisms-mediator-electrode interaction as well as improvement of biofuel cell operational characteristics. The expected economical and ecological effect is related both to green electricity production and waste water treatment technologies.

## References

- Bennetto HP, Delaney GM, Mason JR, Roller SD, Stirling JL, Thurston CF (1985) The sucrose fuel cell: efficient biomass conversion using a microbial catalyst. *Biotechnol. Lett.* 7: 699-705.
- Bennetto HP (1990) Electricity generation by microorganisms. *Biotechnology Education* 1 (4): 163-168.
- Bullen RA, Arnot TC, Lakeman JB, Walsh FC (2006) Biofuel cells and their development. *Biosens Bioelectron.* 21 (11): 2015-2045.
- Cooney MJ, Roschi E, Marison IW, Comninellis C, Stockar U (1996) Physiologic studies with the sulfate-reducing bacterium *Desulfovibrio desulfuricans*: evaluation for use in a biofuel cell, *Enzyme Microb. Technol.* 18 (5): 358-365.
- Das D, Veziroglu TN (2001) Hydrogen production by biological processes a survey of literature. *Int. J. Hydrogen Energy* 26: 13-28.
- Gascon S, Lampen JO (1968) Purification of the internal invertase of the yeast. *J. Biol. Chem.* 243: 1567-1572.
- Hartwell LH, Mortimer RK, Culotti J, Culotti M (1973) Genetic Control of the Cell Division Cycle in Yeast: Genetic Analysis of *cdc* Mutants. *Genetics* 74 (2): 267-286.
- He ZQ, Honeycutt CW (2005) A modified molybdenum blue method for orthophosphate determination suitable for investigating enzymatic hydrolysis of organic phosphates. *Communications in Soil Science and Plant Analysis*, 36 (9/10):1373-1383.
- Kilkenny BC, Hinshelwood C (1951) The Utilization of Carbon Sources by Certain Yeast Strains. *Proc. R. Soc. Lond. B Biol. Sci.* 138 (892):375-385.
- Kim JK, Cho HC, Lee JS, Hahm KS, Park DH, Kim SW (2002) Mass production of methane from food wastes with concomitant wastewater treatment. *Appl. Biochem. Biotechnol.* 98-100:753-764.
- Kosaric N, Velikonja J (1995) Liquid and gaseous fuels from biotechnology: challenge and opportunities. *FEMS Microbiology Reviews* 16:111-142.
- Kozłowska M, Rybus-Zajac M, Stachowiak J, Janowska B (2007) Changes in carbohydrate contents of *Zantedeschia* leaves under gibberellin-stimulated flowering. *Acta Physiologiae Plantarum* 29 (1):27-32.
- Liberatore PA, Cintra 10e – Enhanced Sensitivity from 600-1,200 nm, Analysis of Phosphorus to Sub-ppb Levels. *GBC Scientific Application Notes – UV-Visible*, 35-40.
- Maness PC, Weaver PF (2001) Evidence for three distinct hydrogenase activities in *Rhodospirillum rubrum* *Appl Microbiol Biotechnol.* 57 (5-6):751-756.
- Palmore GTR, Whitesides GM (1994) Microbial and Enzymatic Biofuel Cells. In: *Enzymatic Conversion of Biomass for Fuels Production*, Himmel ME, Baker JO, Overend RP (eds) ACS Symposium Series № 566, American Chemical Society, Washington DC, 271-290.
- Prasad D, Arun S, Murugesan M, Padmanaban S, Satyanarayanan RS, Berchmans S, Yegnaraman V (2007) Direct electron transfer with yeast cells and construction of a mediatorless microbial fuel cell. *Biosens Bioelectron.* 22 (11):2604-2610.





COST- the acronym for European Cooperation in Science and Technology- is the oldest and widest European intergovernmental network for cooperation in research. Established by the Ministerial Conference in

November 1971, COST is presently used by the scientific communities of 35 European countries to cooperate in common research projects supported by national funds.

The funds provided by COST - less than 1% of the total value of the projects - support the COST cooperation networks (COST Actions) through which, with EUR 30 million per year, more than 30 000 European scientists are involved in research having a total value which exceeds EUR 2 billion per year. This is the financial worth of the European added value which COST achieves.

A “bottom up approach” (the initiative of launching a COST Action comes from the European scientists themselves), “à la carte participation” (only countries interested in the Action participate), “equality of access” (participation is open also to the scientific communities of countries not belonging to the European Union) and “flexible structure” (easy implementation and light management of the research initiatives) are the main characteristics of COST.

As precursor of advanced multidisciplinary research COST has a very important role for the realisation of the European Research Area (ERA) anticipating and complementing the activities of the Framework Programmes, constituting a “bridge” towards the scientific communities of emerging countries, increasing the mobility of researchers across Europe and fostering the establishment of “Networks of Excellence” in many key scientific domains such as: Biomedicine and Molecular Biosciences; Food and Agriculture; Forests, their Products and Services; Materials, Physical and Nanosciences; Chemistry and Molecular Sciences and Technologies; Earth System Science and Environmental Management; Information and Communication Technologies; Transport and Urban Development; Individuals, Societies, Cultures and Health. It covers basic and more applied research and also addresses issues of pre-normative nature or of societal importance.

<http://www.cost.esf.org>



**The Institute of Mountain Research: Man and Environment (IGF)**

was founded in 2006 by the Austrian Academy of Sciences. It aims to carry out inter- and transdisciplinary research in mountain areas across the world in cooperation with international groups of scientists. To facilitate this, international networking is a central task of IGF. Since the beginning IGF, in cooperation with the University of Vienna, is responsible for the GLORIA network (Global Observation Research Initiative in Alpine Environments). In 2008 the institute took over the responsibility for the Europe agenda of MRI (Mountain Research Initiative, Berne),

Thematical foci of IGF are: Research on regional sustainability, man-environment relations and global change in mountains.

Methodologically its activities are directed to remote sensing and

laserscanning, monitoring, geo-information, data-bases and data harmonisation, cartography, and field work, but also to new communication technologies and IT-techniques for education.

<http://www.oeaw.ac.at/igf>



**The Federal Research and Training Centre for Forests, Natural Hazards and Landscape (BFW)** is a multidisciplinary Research and Training Centre of the Federal Republic of Austria, constituted as an autonomous institution based on public law. BFW contributes to the economically, ecologically and socially sustainable development of society through the scientific based generation and transfer of knowledge for the multifunctional use of natural resources.

BFW strives for an objective, long-term, application-oriented and interdisciplinary approach. Private enterprises, government decision-makers, public and research institutions capitalize on the services and scientific knowledge made available by BFW.

BFW cooperates closely with other national and international institutions, especially under joint European research, development and training programmes.

<http://bfw.ac.at>

## The Series 'alpine space – man & environment'

### vol. 1

#### **Die Alpen im Jahr 2020**

Roland Psenner, Reinhard Lackner (Eds.)

2006, brosch., 121 Seiten

ISBN: 978-3-902571-01-4

### vol. 2

#### **Politische, kulturelle und wissenschaftliche Perspektiven der nachhaltigen Raumentwicklung in den Alpen**

Axel Borsdorf, Sigrun Lange (Eds.)

2006, brosch., 135 Seiten

ISBN: 978-3-902571-02-1

### vol. 3

#### **The Water Balance of the Alps**

#### **What do we need to protect the water resources of the Alps?**

Roland Psenner, Reinhard Lackner (Eds.)

2007, brosch., 86 Seiten

ISBN: 978-3-902571-33-5

### vol. 4

#### **Ist es der Sindtfluss?**

#### **Kulturelle Strategien & Reflexionen zur Prävention und Bewältigung von Naturgefahren**

Roland Psenner, Reinhard Lackner, Maria Walcher (Eds.)

2008, brosch., 128 Seiten

ISBN: 978-3-902571-32-8

### vol. 5

#### **Über Almen**

#### **Zwischen Agrikultur & Trashkultur**

Christoph Kirchengast

2008, brosch., 148 Seiten

ISBN: 978-3-902571-46-5

### vol. 6

#### **Klimawandel in Österreich**

#### **Die letzten 20.000 Jahre ... und ein Blick voraus.**

Roland Schmidt, Christoph Matulla, Roland Psenner (Eds.)

2009, brosch., 192 Seiten

ISBN: 978-3-902571-89-2

### **Special Volume**

#### **Die Alpen**

#### **Einblicke in die Natur**

Rudolf Hofer (Ed.)

2009, brosch., 160 Seiten

ISBN: 978-3-902719-02-7