



Gabriele Rosenthal (ed.)

# The Holocaust in Three Generations

Families of Victims and Perpetrators of the Nazi Regime

Barbara Budrich Publishers



# The Holocaust in Three Generations

Gabriele Rosenthal (ed.)

# The Holocaust in Three Generations

Families of Victims and  
Perpetrators of the Nazi Regime

2<sup>nd</sup>, revised edition

Barbara Budrich Publishers  
Opladen & Farmington Hills, MI 2010



An electronic version of this book is freely available, thanks to the support of libraries working with Knowledge Unlatched. KU is a collaborative initiative designed to make high quality books Open Access for the public good. The Open Access ISBN for this book is 978-3-86649-740-5. More information about the initiative and links to the Open Access version can be found at [www.knowledgeunlatched.org](http://www.knowledgeunlatched.org)

© 2010 This work is licensed under the Creative Commons Attribution 4.0 (CC-BY 4.0). It permits use, duplication, adaptation, distribution and reproduction in any medium or format, as long as you give appropriate credit to the original author(s) and the source, provide a link to the Creative Commons license and indicate if changes were made.

To view a copy of this license, visit <https://creativecommons.org/licenses/by/4.0/>

© 2010 Dieses Werk ist bei der Verlag Barbara Budrich GmbH erschienen und steht unter der Creative Commons Lizenz Attribution 4.0 International (CC BY 4.0):

<https://creativecommons.org/licenses/by/4.0/>

Diese Lizenz erlaubt die Verbreitung, Speicherung, Vervielfältigung und Bearbeitung unter Angabe der Urheber\*innen, Rechte, Änderungen und verwendeten Lizenz.

This book is available as a free download from [www.budrich.eu](http://www.budrich.eu)

(<https://doi.org/10.3224/86649282>). A paperback version is available at a charge.

The page numbers of the open access edition correspond with the paperback edition.



© 2010 by Verlag Barbara Budrich GmbH, Opladen, Berlin & Toronto  
[www.budrich.eu](http://www.budrich.eu)

ISBN 978-3-86649-282-0 (Paperback)

eISBN 978-3-86649-740-5 (PDF)

DOI 10.3224/86649282

A CIP catalogue record for this book is available from  
Die Deutsche Bibliothek (The German Library) (<http://dnb.d-nb.de>)

Verlag Barbara Budrich GmbH  
Stauffenbergstr. 7. D-51379 Leverkusen Opladen, Germany  
86 Delma Drive. Toronto, ON M8W 4P6 Canada  
[www.budrich.eu](http://www.budrich.eu)

The first edition of this book was published by Cassell, 1998.

Jacket illustration by disegno, Wuppertal, Germany – [www.disenjo.de](http://www.disenjo.de)  
Printed in Europe on acid-free paper by  
paper&tinta, Warsaw

# Contents

Preface .....	3
Part 1: The Dialogue about the Holocaust in Families of Survivors and Families of Perpetrators .....	5
1. Questions and Method .....	7
<i>Gabriele Rosenthal</i>	
2. Similarities and differences in family dialogue .....	13
<i>Gabriele Rosenthal</i>	
3. Similarities and differences in public discourse about the Shoah in Israel and West and East Germany .....	21
<i>Bettina Völter and Michal Dasberg</i>	
Part 2: Families of Survivors in Israel, West and East Germany .....	27
4. Traumatic family pasts .....	29
<i>Gabriele Rosenthal</i>	
5. Surviving together and living apart in Israel and West Germany: The Genzor family .....	45
<i>Gabriele Rosenthal, Petra Jordans and Bettina Völter</i>	
6. The collective trauma of the Lodz Ghetto: the Goldstern family .....	69
<i>Gabriele Rosenthal, Michal Dasberg and Yael Moore</i>	
7. Surviving as inmate-functionaries: The Shapiro/Sneidler family .....	91
<i>Noga Gilad, Gabriele Rosenthal and Yael Moore</i>	
8. Shared and divided worlds: The Stern family .....	123
<i>Waltraud Schade, Sabrina Böhmer and Gabriele Rosenthal</i>	
9. The Kubiak/Grünwald family dialogue: blocking out the theme of migration from Israel to East Germany .....	151
<i>Maria Nooke in cooperation with Christine Müller</i>	
Part 3: Israeli Families of Forced Emigrants from Germany .....	183
10. Families with grandparents of the "Youth Aliyah generation" .....	185
<i>Gabriele Rosenthal, Bettina Völter and Noga Gilad</i>	
11. A love-hate relationship with Germany: The Arad family .....	197
<i>Gabriele Rosenthal, Bettina Völter and Noga Gilad</i>	
12. The intergenerational process of mourning: The families of Fred, Lea, and Nadja Weber .....	217
<i>Gabriele Rosenthal, Bettina Völter, Noga Gilad and Yael Moore</i>	

Part 4: East German Families of Forced Emigrants .....	249
13. Remembering in the light of anti-fascism in East Germany .....	251
<i>Bettina Völter</i>	
14. Anti-fascism as substitute mourning: The Basler family .....	261
<i>Gabriele Rosenthal and Bettina Völter</i>	
15. An anti-fascist "legend"? The Kaufmann Family .....	273
<i>Bettina Völter</i>	
Part 5: Families of Nazi Perpetrators and Accomplices in West and East Germany .....	303
16. National Socialism and Anti-Semitism in Intergenerational Dialogue .....	305
<i>Gabriele Rosenthal</i>	
17. Passing the guilt on to the grandchildren: The Sonntag family .....	315
<i>Gabriele Rosenthal in cooperation with Christine Müller</i>	
18. We are the victims of history: The Seewald family .....	333
<i>Bettina Völter and Gabriele Rosenthal</i>	
Part 6: Two family dialogues compared .....	359
19. Veiling and denying .....	361
<i>Gabriele Rosenthal</i>	
References .....	373
Appendix .....	385
Glossary .....	385
Transcription Symbols .....	387
Authors .....	388

## Preface

After working together for a number of years, Prof. Dan Bar-On and the editor came up with the idea of conducting a study in which we wanted to dare, despite all reservations, to make a comparison between Jewish families and non-Jewish German families. Apart from the content-based problems arising from a comparison of this kind, such a project also raised the question of whether a team of Israelis and Germans would be able to work together successfully over a number of years. Would we even arrive at comparable analyses? In Germany, Prof. Fritz Schütze (University of Magdeburg) and, in the second stage of the project, Prof. Regine Gildemeister (University of Kassel) agreed to get involved with this project, to apply for funding to the German Research Association (Deutsche Forschungsgemeinschaft, DFG) and to take responsibility for it. The funding we received for the project covered the period from December 1992 to August 1996. The editor, Prof. Gabriele Rosenthal (Kassel University), headed the academic research that went into this book.

The team of researchers - the authors of this volume - was an interdisciplinary one, comprised of sociologists, psychologists and political scientists from Israel, West and East Germany; Jewish Israelis and non-Jewish Germans. This constellation led to very different perspectives in the analyses of our interviews; something that proved to be an incalculable advantage. As members of the second and third generation of survivors of the Shoah and of forced emigrants, as well as of Nazi accomplices and Nazi perpetrators, we found again and again that we were trapped in our own perspectives and in some cases had to deal with very different feelings that came up during the course of our work. The critical dialogue within our team, one that spanned a number of years and was not always free from conflict, helped us to grow beyond these limitations. A number of colleagues were helpful to us in this process. Fritz Schütze and Regine Gildemeister acted as our link to the DFG. More than anything else, they put their trust in our work and offered us a great deal of support. We owe special thanks to them, and to our reviewers and the DFG. The study in Israel would not have been possible without Dan Bar-On's support. He assisted us in countless ways, helping us get over some of our interactive low points, giving us many important impulses regarding the content of our work and simply being there to offer advice. We would like to take this opportunity to thank him. We also wish to thank our colleagues Tamar Zilberman and Revital Ludewig-Kedmi, who worked on the project for the first two years. We are grateful to Angelika Heider for the historical research she undertook: the archive inquiries she made required a great deal of effort and persistence.

Catherine Johnson translated most of this book and carefully revised some of the translations we already had. Many thanks to her, and to the other translators, Michael Zuntz, Simon Srebrny, Promita Sengupta, and Libby Shapiro. Johanna Kröber has been transcribing our interviews very carefully for many years now: many thanks to her for her commitment and willingness to help.

Our special thanks go to all the families who agreed to take part in our interviews, who gave us their trust and shared their paths through life with us. All the families who are not directly mentioned in this book were very important to the research process nonetheless, but the scope of this work only allows us to present selected case studies that must serve as examples.

Berlin, January 1997  
Gabriele Rosenthal



Part 1:  
The Dialogue about the Holocaust in  
Families of Survivors and Families of  
Perpetrators



# 1. Questions and Method

Gabriele Rosenthal

What form does the dialogue<sup>1</sup> about the family past during the Nazi period take in families of those persecuted by the Nazi regime and in families of Nazi perpetrators and accomplices? What impact does the past of the first generation and their way of dealing with it have on the lives of their descendants? What are the structural differences between the dialogue about the family past and the Holocaust in families of perpetrators and in families of victims of Nazi persecution? These are the general empirical questions that our research puts forward. The specific focus of our study lies in comparing different family constellations based on whether the first generation can be categorized as having been victims<sup>2</sup>, perpetrators, or Nazi accomplices during the Nazi period. Primarily from a sociological perspective, we examine how family histories that differ biographically after 1945 - in Israel, in West Germany and in former East Germany - affect the process of transmitting the family past from one generation to the next. We look at the process in which family history is passed down through the generations in three generations of Jewish and non-Jewish German and Israeli families. Our aim is to reconstruct constellations in life stories which may facilitate the psychological and social integration of people burdened with a collective and family past that they find threatening. In general, we do this by pursuing an interactive-intergenerational concept which does not view the second and third generations as passive recipients of the past, but rather as active agents in the way they deal with their parents and grandparents and their pasts. Our experience has shown accordingly that the way the first generation interacts with the second and third generation can change their own perspective on the past (cf. Moore 1994).

## *The method*

We do not wish to burden the reader with the methodology and fairly laborious methods involved in our study (Rosenthal 1993b). The few remarks made here serve to facilitate a better understanding of the empirical findings we have reached using our instruments. Findings acquired through an open interview style and hermeneutical case reconstructions can not be compared to

- 
- 1 In our considerations of family dynamics, we are primarily orienting ourselves on the Helm/Stierlin dialogue model (1981/1987).
  - 2 Cf., too, Dan Bar-On's 1995 study on three-generation families of survivors.

quantitative analyses or results based on structured interviews or questionnaires. Statements made by interviewees in response to direct questions about their past and the impact of that past on their lives have a completely different significance than our analyses of latent biographical structures and the family dialogue. In some cases, the insights gained here contrast blatantly with the manifest statements of our interview partners.

In this study, we have conducted **narrative-biographical interviews**<sup>3</sup> with at least one member of each generation in every family studied. After conducting individual interviews with the various family members, we conducted family interviews in order to examine the dynamics within the family dialogue. Our work for this study involved completed interviews of members of twenty families in Israel and eighteen families in Germany. We got in touch with our interviewees through personal contacts - the snowball effect - and through putting advertisements in Israeli and German newspapers.

Before proceeding any further, a brief statement about our interviewing method. At the beginning of every individual interview, we<sup>4</sup> made the following request to the biographer<sup>5</sup>: *"Please tell me/us your family story and your personal life story, I/we am/are interested in your whole life. Anything that occurs to you. You have as much time as you like to tell it. We/I won't ask you any questions for now. We/I will just make some notes on the things that we would like to ask you more about later, if we haven't got enough time today, perhaps in a second interview."* By posing this narrative initial question, we are not specifying any particular theme in the first part of the biographical-narrative interview. Generally, this request to hear the interviewee's family history and life story is followed by a long biographical narration, (i.e. biographical self-presentation) often lasting for hours, not interrupted by questions from the interviewers at any time. The interviewers use nonverbal and paralinguistic expressions of interest and attention to encourage this narrative, which is known as the main narration. This leaves it up to the biographer to determine which themes are addressed, and in how much detail, as well as how they present them and in what sequence. It is only in the second part of the interview, the questioning part of the interview, that the interviewers ask questions about topics referred to in the main narration. In this "questioning period", the interviewer uses narrative questions to initiate more detailed stories or narrations of themes and biographical events touched on in the main

---

3 This interview technique (Schütze, 1976, Rosenthal, 1995a) works with an initial opening question aimed at eliciting and maintaining a lengthy narrative by the interviewee. The method is based on the assumption that narration of an experience comes closest to the experience itself. The narration of biographical events gives social scientists a chance to get a sense of some of the motives and interpretations guiding their subject's actions.

4 Some interviews were carried out by two interviewers.

5 We prefer to use the term "biographer" instead of "autobiographer" in this context. It is our opinion that the latter term does not place adequate emphasis on the social construction of life stories.

narration. In the third part of the interview, the interviewer asks questions about themes that the biographer has not addressed. These questions are also asked with a view to generating narration; we refrain from asking questions like "why?", "what for?", as this would tend to provoke argumentation rather than narration. Our requests to hear more about a certain theme are formulated along these lines: "*Perhaps you could tell us something more about your school years.*" Where our interviewees have trouble remembering certain events, we work with the technique of "scenic memory", to help them put themselves back into scenes in the past. Working from fragments of sense-based or body memories, we help them to gradually reconstruct these scenes by asking them questions about specific details. Provided our interviewees want help remembering, we ask them to put themselves back into the situation in the past and then begin to reconstruct the scene, formulating our questions in the historical present. We move forward from one detail to the next: "*What do you see?*"; "*Who are you standing next to?*"; "*What do you hear?*"; "*Is it dark?*"; "*Is it cold?*". This technique allows biographers to extricate the scene that has been blocked out of their memory; by naming individual details, it begins to take shape. Eventually, our detailed questions are less and less needed, and the biographers can gradually remember the chain of events and begin to translate them into a story. Another type of questioning targets fantasies and dreams that we reconstruct in the same way used in the scenic memory technique. After the interview, we ask our interviewees to make a family sculpture, associate to it and explore what it means to them, much like the technique used in family therapy (Jefferson, 1978, Papp et. al., 1973, Simon, 1972). We give them adhesive circles in four different colours and ask them from their own perspective to group themselves and the members of their family by their emotional closeness or distance (putting them into positions that symbolize their relationships). When the sculpture is finished, we ask them to make a one-sentence statement to each member of their family and then to have each family member say a sentence back to them. The interviews are done in a research setting, rather than in a clinical environment. None of our first generation interviewees have ever been hospitalized for mental health reasons<sup>6</sup>. It should be noted, however, that we see our interviews as social-therapeutic intervention that facilitates communication. In the course of telling their stories, a number of our interviewees have become more aware of the extent to which their feelings, behaviour and fears are related to their family past. After a general analysis of the individual interviews, we decide which family members we wish to invite to take part in a family interview. The consideration of how we can best help the family to open up the family dialogue is a key criterion here. Like Ivan Boszormeny Nagy und Geraldine Spark

---

6 We have since discovered that two of our third-generation interviewees have required psychiatric treatment at certain times and have spent time in a clinic.

(1973) or advocates of the Stierlin School (Stierlin et al. 1987), we are thinking here in terms of helping to uncover family secrets and making family members aware of strong invisible bonds of loyalty as well as encouraging them to deal with family myths in a more reality-oriented way. In this process, it is important to ensure that the combination of family members chosen for the family interview does not lead to a discussion of too many or too different conflicts in one interview. This is why we conducted two family interviews in a number of families with different constellations each time. Our experiences illustrate the effect of these interviews in terms of opening the family dialogue, an impact that can be considered the start of family restructuring. We open the family interview either with the question: *"What is it like for you to be taking part in a joint interview?"* or with the request that they tell us what has happened in the family in the meantime since our last visit. From here, our interviewing method concentrates primarily on asking one interviewee to take on the perspective of another (i.e. *"Can you imagine how your mother feels about this?"*) or asking one family member what impact another member's statements has on them (i.e. *"How do you feel after what you've just heard from your father?"*). A further intervention is undertaken using the following question: *"Are there any questions that you would like to ask your relatives?"* The method used here **to analyse** narrated family and life stories is one of hermeneutical case reconstruction<sup>7</sup> developed by the author over many years in combination with various other methods. In analysing the interviews, particular attention is paid to the structural differences between what is experienced and what is narrated: between experienced life and narrated life, i.e. life history and life story<sup>8</sup>. On the one hand, we tried to reconstruct what the biographer actually experienced during this sequence of their life and, on the other hand, how they present their life in a present-day interview. In analysing their biographical self-presentation, or life story, what we are aiming to achieve is an analysis of the biographer's present perspective. We interpret in what form, i.e. at what sequence of the text, they speak about certain parts of their lives, and we reconstruct the mechanisms behind the themes they choose to talk about and the experiences they choose to tell. We assume that it is by no means coincidental and insignificant when biographers **argue** about one phase of their lives, but **narrate** another at great length and then only give a brief **report** of yet another part of their lives or **describe** the circumstances of their lives in detail. As the analysis proceeds, it becomes clear how the indi-

---

7 For details of the hermeneutical case reconstruction procedure, cf. Rosenthal, 1993, 1995a. Reconstruction and sequentiality are the key principles in this method. The texts are not subsumed under specific categories, but rather are analysed for meaning in the context of the entire text (= interview). The sequential compilation of the text of the life story and the chronology of biographical experiences in the life history play an essential role.

8 By life story we mean narrated personal life as related to another in conversation or as written down in the present-day; by life history we mean the experiences that a person has lived through.

vidual sequences of the main narration are thematically linked. In this context, we speak of thematic fields, referring to Aron Gurwitsch (1964). The underlying assumption is that the narrated life story does not consist of a haphazard series of disconnected events, but that the narrator's autonomous selection of stories is based on a context of meaning, namely, the biographer's overall interpretation. The narrated life story thus represents a sequence of mutually interrelated themes, which between them form a tight network of interconnected cross-references (Fischer 1982, p. 168). In Aron Gurwitsch's terminology, the individual themes are elements of a thematic field. The construction of a genogram of the family under analysis is of considerable help in this process. This schematic diagram of the relationships within the family system based on the family tree is helpful for recognizing complicated family structures as well as historical developments and the complexes of problems linked to them within the family. Only now do we begin to formulate initial readings or questions about the family system that offer orientation in analysing the life stories. It is at this point that we start to undertake historical research and archive inquiries. However, for reasons of personal data protection, we are not always able to give an exact account of our findings or of the information that we turned up in the archives. To this end, we have also changed not just names, but in some cases places and other personal data as well. Slight historical discrepancies or inaccuracies may crop up as a result. The general questions behind our analysis can be formulated as follows: how is the collective and family past integrated into the presentation of the individual's life story? What significance is assigned to this past in the biographical construction of the biographer? What form does the interplay between the individual life stories and the interactively generated family story take?<sup>9</sup> What biographical repair strategies are used to heal the effects of a threatening past? As biography researchers, we are working on the assumption "that a deviation from the normal represents an active life achievement, which in itself entails the solution to a problem and which has a certain function in the life history in question" (Fischer-Rosenthal 1992, p. 20). Thus, we make a concerted effort not to subsume the development of symptoms into psychopathological concepts, but rather to reconstruct their function in the individual's biography and family system. In doing so, we refrain from evaluating them, for example, by dividing symptoms up into conscious coping mechanisms and unconscious defence mechanisms. Accordingly, we tend to initially develop our concepts in a descriptive manner, in the sense of the question: how is the past dealt with in the individual's biographical construction and in the family dialogue?

---

9 By family story we mean the shared construction of a single family history in the family dialogue.

## *General findings*

An empirical comparison of families from West Germany, East Germany and Israel demonstrates clearly that the structural differences inherent in the family dialogue with regard to National Socialism result less from differing socialization processes after 1945 and more from pre-1945 differences. That is, these pasts have a far greater impact on the biographer's deep structure than the family history after 1945, be it in Israel, in West Germany or under socialism in former East Germany. It is of crucial importance for the life stories of subsequent generations, as well as for the dialogue within the individual family, whether and, if so, how the great-grandparents, grandparents or parents were persecuted in Europe, and how they survived this persecution. Or, on the other hand, to what extent and how the grandparents were implicated in Nazi crimes. Our analyses indicate that the Jewish families we interviewed differ considerably depending on whether the generation of the grandparents<sup>10</sup> survived ghettos or concentration camps and death camps or whether they were able to leave Eastern Europe or Germany before 1939. A contrastive comparison showed that the families of these two groups demonstrate both different family dynamics and different family and life history constructions in all three generations. Both the family dialogue and the individual biographical constructions are defined by different themes in each case. In families of survivors (cf. Part 2), the operative themes are "death" and "fear of extermination", whereas the family and life histories of families of forced emigrants - regardless of whether they now live in Israel, West or East Germany - revolve around the themes of "emigration" and "life in the new society". However, it becomes apparent that in Israel, but not in Germany, the children of young forced emigrants tend to block out the theme of "emigration", because, unlike the second generation of Holocaust survivors, they wish to present themselves as Sabres, as Israelis with no European roots (cf. Part 3). Families from former East Germany, on the other hand, have been able to embed the theme of "emigration" into their socialist self-conception in all three generations, for by emigrating, their grandparents were either setting out on their "anti-fascist" path through life or were continuing along it (cf. Part 4). We have structured the book into the following parts in accordance with these empirical findings, distinguishing between families of survivors (Part 2), of forced emigrants in Israel (Part 3), of forced emigrants in East Germany (Part 4) and families of Nazi perpetrators and accomplices (Part 5).

---

10 Many of the grandparents living in Israel who took part in this study were interviewed as early as 1989/1990 by Gabriele Rosenthal within the scope of a study on survivors of the Shoah.



## 2. Similarities and differences in family dialogue

Gabriele Rosenthal

Do descendants of Nazi perpetrators and descendants of survivors of the Shoah have similar problems? This question is one being raised more and more frequently in academic discourse and in everyday life. So far, responses to it have had a tendency either to equate the two, a position expressed in an article by Mona Weissmark et al (1993), or to vehemently reject any possible similarities. A growing number of self-help groups, set up to provide a forum for descendants from different types of families to talk about their family past and the suffering it causes them, struggle between an open and sometimes aggressive dialogue about the differences and dealing with them in a harmonizing way (Dan Bar-On 1995b).

At first glance, similarities do emerge in a comparison of how Jewish families, in which the grandparents either survived the Shoah, or managed to flee Germany in time, deal with their traumatic past under National Socialism and how families, in which the grandparents were either Nazi perpetrators or active National Socialists, deal with their past. Whereas the way the first generation deals with the past differs significantly depending on whether they were among the victims, perpetrators or accomplices (cf. Section 2.1.1), descendants of both families of victims and families of perpetrators exhibit the following symptoms: blocking out information about the family past, fear of extermination, separation anxiety, guilt feelings, impeded separation-individuation process, and acting out the past in fantasies and psychosomatic symptoms. In addition, similar mechanisms can be observed in the inner-family dynamics within families of those who were persecuted and within families of persecutors. The silence surrounding the past, that has institutionalized itself within perpetrator families, also extends to families of those who were persecuted (Danieli, 1982). Moreover, in both kinds of families, one may observe the tremendous impact of family secrets (Karpel, 1980), as well as family members obstructing each other in any attempt to address themes relating to the past, accusations that render family dialogue impossible, an institutionalization of family myths (Ferreira, 1963) to circumvent conflict within the family, and a bound family system (Stierlin, 1981) resulting from a problematic past.

Behind these manifest similarities on a superficial level, however, lies the level of the latent deep structure, which is different in each case depending on the experiences in the family past. In other words, no matter how strong the superficial similarities, their function within the family system, and, more specifically, their psychological impact on individual family members differ based on the differences in the family pasts.

In survivor families, the silence of the grandparents about their experiences is connected to completely different problems and motives than the silence of grandparents who were implicated in Nazi crimes. A grandmother who survived the ghetto and the death camp is not denying the persecution in her past if she does not speak about it, whereas this certainly is the case when Nazi perpetrators or accomplices remain silent. If she does not articulate this part of her past, one of her reasons for choosing not to do so is an attempt to protect her children and grandchildren from the fantasies and nightmares that haunt her. Survivors very often remain silent to spare their children the burden that weighs so heavily on them and to avoid exposing others to their painful experiences (Danieli, 1982). In contrast, a grandfather and grandmother or parents who were implicated in Nazi crimes primarily keep silent and deny the past to protect themselves from accusation or loss of affection. Similarly, common reactions found in children or grandchildren of survivors are motivated by different causes than those found in descendants of perpetrators. Examples of such reactions include withdrawing from the horror depicted in survivors' narrations of persecution and killing, failing to grasp the full meaning of certain details of the experience, or even repeatedly forgetting the information that has been communicated to them. These self-protective responses are an attempt to ward off very different pressures than those that children or grandchildren in perpetrator families are trying to evade, even if they use similar methods of self-protection. Children and grandchildren of survivors do not want to imagine their parents and grandparents in situations where attempts were made to rob them of their human dignity and where they were helpless to prevent the humiliation and murder of other people, such as their parents, siblings or even their own children. Another reason that they resist knowing and realizing what their grandparents or parents suffered is because they feel guilty for not being able to relieve them of this suffering or for not having endured this suffering themselves. These guilt feelings "include the pressure to compensate parents with *naches* (happiness) for their suffering through accomplishment; a desire to protect and care for parents; a deep sadness and pain awakened by Holocaust memories; and feelings of powerlessness to undo the Holocaust for their parents" (Klein-Parker 1988, p. 208). In contrast, descendants of Nazi perpetrators are protecting themselves from having to realize the cruel deeds, lack of guilt feelings, emotional coldness and racism and anti-Semitism that continue unabated to this day in their closest reference individuals. And they are also trying to defend themselves against both guilt feelings and fear that their grandparents or parents will murder them or classify them as *lebensunwert* (a Nazi term meaning "unworthy of life").

A fear of being murdered that in some cases intensifies into a genuine **fear of extermination** is something we find in children and grandchildren of both perpetrators and survivors. Fear of extermination in children and grand-

children of perpetrators tends to relate to an unconscious fantasy of being murdered by their own parents (cf. Kestenberg/Kestenberg 1987; Rosenthal/Bar-On 1992), while the potential threat that children of survivors feel tends to be a general anxiety towards the extra-familial and non-Jewish world<sup>11</sup>. In descendants of perpetrators, we also observe a fear of being considered "unworthy of life". Thus, for instance, the daughter of a Nazi euthanasia physician felt this fear as a child in connection with her father and concealed her shortsightedness from him for this reason (Rosenthal/Bar-On 1992). As a child, she had to witness her father throwing her younger brother, a mere baby at the time, into a swimming pool as a test aimed at dispelling his father's doubts of the child's "racial purity". Children and grandchildren of perpetrators also express fears of being murdered by their parents or grandparents if they attempt to expose the family past. A grandson of a Nazi perpetrator, who talked to his grandfather, trying to motivate him to admit his crimes with a certain amount of success, barricaded himself in his room the night of the conversation. He was tormented by the fantasy that his grandfather might shoot him because he was on to his past or was beginning to dissolve the bonds of loyalty he felt towards his grandfather. In another of the families we interviewed, a son of a perpetrator has had a recurring dream since childhood that he is being choked to death by unknown men who sneak up behind him soundlessly. Just a few years before our interview, his father told him that he *"always keeps a length of wire with him to throttle the enemy silently from behind, like a sentry for example"*. His son also imagines taking part in a special duty operation with his father and being murdered by him because he has proven unsuitable for the task. He knows for a fact that rather than leave wounded comrades in enemy territory, his father and his unit murdered them instead. In contrast, descendants of survivors often become afraid in situations that they - often unconsciously - associate with the persecution in their relatives' past. For instance, one hears of them becoming mortally afraid of being gassed when they enter unknown or confined spaces. The grandson in the Goldstern family presented below suffers from a phobia of heights, of being pushed down from somewhere high. In the ghetto, his grandmother had to witness her girlfriend being thrown out of a window by a German.

**The separation anxiety** that may be observed also differs significantly in all three generations if we are comparing families of survivors and those of Nazi perpetrators. While in families of survivors, anticipated separations trigger deeply-felt mortal fears on both sides, by the abandoner and the abandoned (Barocas & Barocas 1979); with perpetrators and their relatives, an impending separation from the family triggers a fear of their crimes being exposed and of the emotional consequences that may result from this. For

---

11 For more on fear of persecution or extermination in the third generation, cf. Ahlheim (1985); Rosenthal, P.A. / Rosenthal, S. (1980).

survivors, present-day separations that do actually occur reactivate their memory of the separation they experienced from family members whom they lost in the Shoah (Shiryon 1988, p. 241). When descendants of Nazi perpetrators separate or distance themselves from their parents or grandparents, the latter become afraid that their descendants might now begin to ask questions and discover new perspectives outside of the family that could threaten the family myth.

A further phenomenon common to families of perpetrators and families of victims is the bond that the second and third generation feel to their family of origin, one which often considerably impedes their **separation-individuation process**. Descendants of survivors often assume the caretaker role in their families and learn to look after their parents, suppressing their own needs in the process, especially their conflicts and desires to separate during adolescence, and their aggressions towards their parents. No detailed description of the disorders in their separation-individuation process is needed here, as they are well-documented in clinical case analyses (Barocas & Barocas 1979; Davidson 1980; Freyberg 1980). Bar-On's interviews with children of Nazi perpetrators (1989) indicate that they tend to either have strong bonds to their parents and thus to deny or dispute their Nazi past, or to completely break off contact with their parents and completely reject them. We can also interpret this disassociation from their parents, often accompanied by self-hatred, as a form of bond to their parents. Their separation-individuation process is impeded by their concerted effort to be different than their parents, to reject or deny any possible similarities in themselves, to lead a different life and above all to suppress any desire to have contact with their parents. Our analyses, which focus more on family dynamics than on individual psychodynamics, indicate that where there are a number of children in both families of perpetrators and of survivors, different roles are allocated to each child: for example, one child assumes the position of the parents' bound delegate<sup>12</sup>, while another leaves the family and takes on the role of the accuser. Another common pattern is that of a very bound family structure in the children's and grandchildren's generation in conjunction with an exclusion or avoiding of contact with the grandparents' generation<sup>13</sup>. One of the functions this serves is that described by E. Sperling (1979, p. 211) of "not being unfaithful to the past by not coming to terms with it". By keeping contact to the grandparents to a minimum, an attempt is made to maintain the illusion of being a good family nonetheless, of not threatening the family myths or, worse still, airing the family secrets.

Our case analyses show clearly that silence and family secrets as well as family myths constitute some of the most effective mechanisms of ensuring

---

12 Yael Danieli's clinical experience (1982) is that the firstborn child generally takes on this role in families of survivors.

13 Cf. the Kaufmann family; cf. Chapter 4.3.

the sustained impact of a problematic family past. This is true in families of survivors, perpetrators and Nazi accomplices. This can be more generally formulated as: the more closed or guarded the family dialogue, or the greater the attempt to make a secret of or whitewash the past, the more sustained the impact of the family past will be on the second or third generation (Bar-On, 1995, Danieli, 1993, Sigal et. al., 1973). Our biographical case reconstructions indicate that these subsequent generations often unconsciously suffer from extremely detailed fantasies relating to undisclosed family history or family secrets. It emerged very clearly in the families we analysed that these fantasies correspond quite remarkably in their content to the specific experiences in the parts of the family history that are denied.

An aura of secrecy and shame hangs over survivor families where crucial information and experiences are not passed down to subsequent generations. "The children develop fearful and embarrassed attitudes to the 'family secret' and often weave horrifying fantasies about what was done to their parents and how they survived" (Davidson, 1980, p. 19). The children and grandchildren of Nazi perpetrators, on the other hand, are preoccupied with fantasies from the perspective of the perpetrators as well as with conceptions about their crimes. At the same time - unlike the descendants of survivors - they keep trying to soothe themselves by telling themselves that these fantasies are not remotely grounded in reality or are not connected to the family history. However, in the case of some children and grandchildren, far from alleviating their unease, these attempts to soothe themselves make them begin to doubt their own perception and fear that they suffer from psychotic delusions.

The respective family secrets differ both in content and in function within families of survivors and those of Nazi perpetrators or accomplices. The fantasies created around these secrets by the subsequent generations are also correspondingly different in content. These fantasies revolve either around the powerlessness and suffering experienced by a survivor, or around the crimes of a perpetrator. Moreover, the psychological dynamics differ in each case, too. Examples from the Sonntag and Steinberg families offer some preliminary insights into these differences. Both in the Sonntag family, where the grandfather was very likely implicated in Nazi crimes, and in the Steinberg family, where the grandmother survived the Shoah, the children and grandchildren only have access to certain information and fill in the gaps with their fantasies. The creation of such fantasies demonstrates how, despite narrative silence, the grandparents' experiences and deeds are handed down on a latent level.

In the Sonntag family (Chapter 5.2), the grandfather, whom our archival research shows may well have been involved in constructing crematoria in concentration camps, wonders how there could still have been so many corpses left after 1945, arguing that they tried to burn them all. His whereabouts during the war, and the crimes he was implicated in, remain a secret

within his family. His son, however, continues to ask "burning" questions with regard to his own life story; he is preoccupied with whether he could bring himself to shoot people or even burn women and children locked inside a church building. He subsequently concludes that, though he does not think he could, he "*wouldn't put my hand in the fire to prove*" that he would not be. He exonerates the perpetrators of such crimes mainly by blaming them on the victims. One of the main arguments he puts forward is that, in some places, the victims themselves were to blame for the Nazis murdering their entire population, because they aided and abetted the partisans. On the other hand, in the Steinberg family (cf. Zilberman & Rosenthal 1994), the interview with the mother, who was tortured as a political prisoner and incarcerated in several concentration camps, is riddled with unspecified allusions to repeated abuse and rape. In her own narrative, the daughter, who is extremely close to her mother, makes veiled allegations against her. On an unconscious level, she is haunted by the fantasy that her mother prostituted herself to the Nazis.

Thus, we have the son of an alleged perpetrator tormenting himself with the question of his own potential to perpetrate such crimes, and exonerating the real perpetrators in the process and, instead, blaming the victims for the crimes committed against them. In contrast, the daughter of a survivor struggles with suppressed accusations against her mother and with the guilt feelings that these generate in her. These scenarios clearly illustrate the way that a pattern, that exists in the first generation, is handed down to later generations. While the real perpetrators attempt to deflect responsibility from themselves by blaming the victims (Rosenthal, 1992), survivors continue to be plagued with guilt for having survived, and repeatedly call into question having abandoned their parents, or their failure to help others in certain situations, or else torment themselves by asking why they only thought of themselves during "selection procedures", instead of thinking of those who were being sent to their death in the gas chamber. Their children take on these feelings of guilt at having survived, too, and feel guilty for not being able to make their parents' past go away, as well (cf. Danieli 1980).

Our analyses of family dialogues also show that coalitions of family members blocking a discussion of a family past, that weighs very heavily on all of them, can be a decisive precondition for a closed or bound family system being formed and maintained. Thus, the more comprehensive the silence about the past, the more closed the respective family system. The bound family closes itself off from the outside world, while at the same time permitting almost no limits to be set between individual family members. These families, of which the Seewald family discussed in Chapter 5.3 is an example, avoid conflicts, cultivate a harmonizing style of communication, and place large parts of the family history under taboo (Wirsching & Stierlin 1982, p. 123ff.). To avoid having to address the theme of threatening parts of their past, bound families often tend to create family myths (Ferreira 1967): unquestioned justi-

fication strategies shared by all the family members, a collectively maintained belief that factually diverges from reality.

A comparison of survivor and perpetrator families also illustrates structural differences with regard to the content of family myths. In survivor families, the construction of and identification with such myths focuses on the themes of "strength" and "resistance" (such as the fantasy that the grandfather boxed an SS officer). In families with a Nazi past, this takes on the form of emphasizing the victimhood of the family members. In the Seewald family below (Chapter 5.3), we will examine the fabricating interpretation, complete with detailed fantasy images, of how the grandfather was a victim in a prisoner of war camp. A striking feature in Jewish families is the fact that children and grandchildren of grandparents who both survived concentration or extermination camps take a particular interest in finding parts of their family history related to "fighting". The Goldstern family, for instance, (Chapter 2.3) identify strongly with the grandmother's brother, who was killed in action during the War of Independence in Israel. An analysis of this family dialogue illustrates that identifying with this great-uncle serves as a repair strategy that attempts to heal intense feelings of powerlessness. While on a superficial level, this phenomenon may be explained as an expression of collective interpretation patterns institutionalized in Israel, it is also found in families of Jewish survivors living in Germany.

In non-Jewish German families, one repeatedly comes upon the myth of the "clean" soldier who helped enemy civilians or even treated prisoners of war with respect, maintaining a sense of justice in the midst of injustice. This belief corresponds to the long-standing social myth of the "clean" *Wehrmacht*, whose members, unlike those of the SS, were supposedly not implicated in dishonourable crimes.<sup>14</sup>

---

14 An exhibition and publication by the Hamburg Institute of Social Research entitled "A War of Extermination: Crimes of the Wehrmacht" have contributed to calling this myth into question in Germany to some extent (Heer & Naumann, 1995). The exhibition has traveled to several cities in Germany and has unleashed innumerable controversies.





### 3. Similarities and differences in public discourse about the Shoah in Israel and West and East Germany

Bettina Völter and Michal Dasberg

The phenomenon of collective silence about the Shoah is something we find in Israel and in West and East Germany. In all three societies, the history of the genocide and its aftermath only gradually found its way into public discourse. However, this development must be seen differently in the historical and social context of each country.

**In Israel**, the 1940s and 1950s were defined by great ambivalence towards the Shoah and its victims. In the struggle for an independent country, the ideals of Zionism were definitely in the foreground. The "Yishuv", or community of Jews in Palestine, before a Jewish state existed, pinned its hopes on the new generation of "Sabres", Jews born in Palestine or Israel: they were to build the country and defend it (Segev 1993). In contrast, the survivors of the Shoah, who immigrated to Palestine and Israel after the liberation, corresponded to the negative cliché of the conforming, helpless Jew in the Diaspora. In the eyes of the Zionists, they were "human dust". The history of their persecution was more or less a taboo in public discourse: in Palestine, the media hardly covered the Nuremburg trials, for instance. This conspiracy of silence *"was accompanied by harsh value judgements, which blamed the survivors, who went, it was said, like sheep to the slaughter"* (Bar-On 1995, p. 19). The group of survivors, who had fought in the Warsaw ghetto uprising and those who had died in it, partisans and other members of the Jewish Resistance, came closer to corresponding to the ideal of the Zionist hero, however. They were awarded public recognition and gratitude. This differentiating attitude towards survivors and those who died in the Shoah was expressed in the prevailing culture of memory. Thus, the Remembrance Day to the Shoah and Heroism (*Yom HaShoah veHagevurah*) was moved to the date of the Warsaw ghetto uprising. The name of this day of remembrance - "to the Shoah and Heroism" - expresses the importance assigned to resistance.

The Eichmann trial in 1961 represented a turning point in Israel's culture of memory. The trial, which contained accounts and testimonies of the persecution and suffering endured by survivors, was broadcast on public radio, focusing public attention on this theme (Danieli 1980; Segev 1993). From this point on, the Shoah was not only linked to the history of the Jewish people, but to the history of the founding of the state of Israel.

Caught by surprise in the Yom Kippur War of 1973, Israel began for the first time to identify more with the powerlessness of the victims of the Holocaust. Nonetheless, a socially imposed tendency in Israel to focus on the "heroic", with issues of powerlessness remaining unvoiced, was operative until the early 1980s. It is only in the last ten to fifteen years that survivors have been denounced less for showing weakness during their persecution, and that a growing number of them have begun to speak about their past. An educational project launched in Israeli high schools in the seventies has also contributed to this. About the time of their Bar-Mitzvah/Bat-Mitzvah, all young people are given an assignment to ask their parents and grandparents about their pasts and write down their family history. Many Holocaust survivors tell their story for the first time in connection with these "roots papers".

In the wake of the 1982 Lebanon War and later during the Intifada, there was very vocal criticism in Israel of the army's actions and its treatment of civilians. In television reports, commentaries, poems and songs, Israelis protested publicly against the military operations sanctioned by their state and warned - also in reference to the Shoah and National Socialism - against the violation of human rights. During the Gulf War in 1991, when the population had to seek shelter in sealed rooms and bunkers from possible poison gas attacks by Iraq, the great majority of Israelis began to identify with the victims of the Shoah. In fact, the end of the 1980s marks the beginning of a public discussion - both in film and literature - of the tribulations not only of survivors but also of their descendants. While the years before this turn of events were characterized by a collective attempt to differ from the Diaspora and shed all types of behaviour reminiscent of it, now many families began to unearth their memories and let their origins show. Part of this process involved numerous families going back to their European names which they had hebraized after coming to Israel.

**In West Germany**, widespread silence around the issue of Nazi crimes became institutionalized and the prevailing myth was one of an innocent populace that had followed Nazism unsuspectingly. According to this myth, the responsible Nazi perpetrators had all been sentenced in the war crimes trials. The collective majority of Germans was thus free to reassure one another that they had seen and heard nothing about the persecution of the Jews, or about others who were persecuted, until 1945. Empirical analyses of life stories by Germans who were not persecuted (Rosenthal 1990; 1993a) illustrate the myriad of ways in which members of all generations attempt to extricate accounts of their lives from any possible complicity with the Nazi regime. Although, for several years now, the media have been trying to address the theme of Nazi crimes in a very general way, this has hardly ever taken the form of examining the reality of people's experiences during that time. This silence surrounding the issue of the perpetrators and of Nazi crimes experienced by bystanders has led over time to certain rules being established that

effectively obstruct any intergenerational or intragenerational dialogue. Even the enormous amount of energy brought into the debate on anti-fascism in West Germany by members of what is known as the (19)68 generation could not stop them from unconsciously obeying these rules, in spite of their concerted effort to re-examine fascism, criticize relics of the "Third Reich" in post-war society and squarely confront their parents' generation with its complicity in the Nazi regime. It emerges in our interviews with members of the '68 generation, how little they actually know about their own family histories. Often the very act of accusing their parents or grandparents of being Nazis functioned as a very effective defence mechanism against any specific knowledge of their relatives' actual pasts as Nazi perpetrators or accomplices (Rosenthal 1995b). However, the genocide of the Jews did become an issue of public debate leading to wider social dialogue after the first broadcast of the US television series "The Holocaust" in 1979 (Märthesheimer/Frenzel 1979). This more extensive debate of Nazi persecution and the fate of those who were persecuted - in the media, in school and even within families - do not, however, rule out a reluctance or even resistance to directly addressing the question of perpetrators either in public discourse or within families. It must be said, however, that members of the younger generation are increasingly confronting the impact of the past on the children and grandchildren of perpetrators.

**East Germany** saw itself, contrasted to West Germany, as the true anti-fascist Germany and as the successor state to the Resistance movement. Its supporters declared the socialist state free of all continuity to the Nazi past. While in West Germany, all debate that focused on the Holocaust more or less ignored the issue of political resistance, in East Germany exactly the opposite held true. Here, communist resistance to Nazism was overemphasized and the Shoah was played down (Kulturamt Prenzlauer Berg et al 1992). The passive Jew, who was not politically active and was unable to save himself for this reason, was the dominant image. This image was contrasted with the anti-fascist member of the Resistance, styled as a hero, who had read the signs of the times early on and had risked his life in the anti-fascist struggle. Jewish resistance fighters were often exalted as anti-fascists, but their Jewish background was completely ignored. Our interviews illustrate how this absence of a public discourse on 'racial' persecution contributed to the Holocaust and Jews being talked about even less in East German families than they were in West German ones.

In East Germany, the Eichmann trial of 1961 also initiated increased debate about the National Socialist mass annihilation. But here, the power apparatus tried to use this issue as a weapon to fight the Cold War: West Germany was presented as the land of the murderers and anti-Semites while East Germany was stylized as the sole heir of anti-fascism (Wolffsohn 1995, p. 27-56).

The eighties heralded a significant growth in public interest in Jewish life in East Germany and in remembering the Shoah. Initiatives such as the decision to rebuild the New Synagogue in East Berlin must be seen in the context of growing international interest in Jewish issues (Bodemann 1996, p. 106f). In 1988, the East German regime unexpectedly signaled its fundamental willingness to make restitution payments to Jews who had been persecuted by the Nazis. The State Department's demand that it settles Jewish compensation and restitution claims had gone unheeded since 1973. Now, the country's desolate trade balance made diplomatic and economic relations with the US urgently necessary, forcing it to make these concessions. But the East German regime continued to reject any share of the responsibility for National Socialist crimes (Goschler 1993, p. 110). And it was only in 1990 that the People's Chamber finally approved a resolution that East Germany - in the final throes of its existence - recognized the state of Israel.

Since the fall of the Wall in 1989, both parts of Germany have seen a decidedly critical public rethinking of the anti-fascist culture of memory that tended to emphasize the Resistance and keep silent about the genocide and its perpetrators. It was now possible to give new emphasis to sites of public commemoration, such as the memorials where the concentration camps of Sachsenhausen and Buchenwald once stood. Holocaust exhibitions were rearranged to allocate more space to the genocide, while at the same time paring down the parts of the exhibition devoted to political resistance. Public debates like the dispute unleashed by Daniel Goldhagen's book "Hitler's willing executioners" (1996) or the controversy arising from the exhibition entitled "A War of Extermination. Crimes of the *Wehrmacht*" (cf. Heer/Naumann 1995) addressed the theme of crimes perpetrated by the "perfectly ordinary" German.

On the whole, it must be stressed that the silence surrounding the Holocaust has similar motives in both East and West Germany, but altogether different ones in Israel. A concluding comparison, that examines the different ways in which Jewish families in former West and East Germany and in Israel deal with the past, aims at shedding more light on the differences in social dialogue on the Holocaust in these three countries.

Until well into the 1980s in **former East Germany**, there was a strong tendency not to talk about having a Jewish background, about persecution or even about anti-Semitism experienced after 1945. By contrast, the history of political resistance and anti-fascist elements in the family past tended to be stressed (cf. Part 4). This was part of an identification with the socialist ideals propagated by the East German state (Ostow 1989). In other words, this way of dealing with the family history was symptomatic as well as reflective of the general way in which East German society dealt with the Nazi past. Moreover, the state placed little value on the development of Jewish self-awareness. According to the official state definition, only those who were

registered members of one of the eight religious Jewish Community Centres were considered Jewish (Runge 1990, p. 942f). And yet estimates indicate that the number of Jews living in the East German state was actually ten or fifteen times greater than the number of members of the Jewish Community Centres suggest (Ibid., p. 156). The more their faith in the socialist state crumbled, the more some felt the need to reflect on their Jewish background. With the demise of the East German state, even communists of Jewish descent began to concern themselves with Jewish culture and their family past (Genin 1994, p. 383-402). Thus, for instance, from 1985 on, over 200 East Berliners with biographical links to Judaism, who felt a need for a Jewish-Jewish dialogue, formed the "We-for-us" group under the auspices of the Jewish Community Centre (Runge 1990, p. 944f).

The self-definition of Jews living in **West Germany** was based to a greater extent on their Jewishness. However, even here, many of them played down their Jewish identity and acquired a form of self-presentation, which allowed them to avoid necessarily being identified as Jewish within non-Jewish circles, until well into the eighties (cf. Chapter 2.2). Furthermore, they avoided raising the issue of Nazi crimes within the realm of public discourse. Eventually, though, some of the children of families of Jewish descent began to voice their political opinions on these issues more openly.

While Jews in East Germany identified with the East German state, we can observe that in West Germany many Jews have a negative bond to the country they are living in. A comparison of Jewish families in the two countries must consider the fact that the life histories of the grandparents living in each state had very different trajectories before 1945. In West Germany, most of the generation of Jewish grandparents were camp survivors of Eastern European origin who had gone to Displaced Persons camps right after the liberation (Richarz 1988). In East Germany, on the other hand, a large number of them had been members of the Resistance or had emigrated from Germany before 1939 and, as members of the Communist party, had decided to return to live in a socialist state after the war. Those, who were forced to emigrate and subsequently returned to East Germany, bear interesting similarities to those who left Germany before 1939 for Israel as part of the Youth Aliyah. In Israel, both the first and second generations of these families generally live on a kibbutz and often hold strong decidedly Zionist views. Analyses of interviews with them show that, among other things, identifying with Zionism serves to alleviate the guilt that torments the first generation (cf. Part 3), who accuse themselves of having abandoned their relatives to die in Europe while they were able to build a new life for themselves in Israel. Both identifying with Zionism in Israel and identifying with the socialist state in former East Germany are therefore accompanied by playing down the negative aspects of each system.



Part 2:  
Families of Survivors in Israel, West and  
East Germany





## 4. Traumatic family pasts

Gabriele Rosenthal

### *Disjointed lives - fragmented life stories*

#### Social functions of remembering

A comparison of the life stories of Holocaust survivors with those of German accomplices and also perpetrators (Rosenthal 1990, p. 1991) indicates certain structural differences. These differences can roughly be characterized as follows: while non-Jewish Germans who did not suffer persecution - the accomplices of the "Third Reich" - can easily narrate their experiences during World War II at great length, survivors have considerable difficulties with the processes of remembering and narrating what they went through. In fact, one can even say that for German accomplice biographers who were not persecuted, the war period generated autobiographies; whereas in the case of survivors, this period actually impeded autobiographies. For women and men who were accomplices and perpetrators, the war generated detailed, epic, and dramatic narrations (Rosenthal 1991). In contrast, the life stories of biographers who suffered persecution are primarily comprised of isolated events or fragmented stories, or of a disjointed narration of a chain of events, in which they jump back and forth between several time frames. These disjunctures lead to considerable inconsistencies in the chronology of narrated events. Even life stories of Holocaust survivors characterized by an obsessive narration of the persecution exhibit the same fragmentation within individual stories as well as in the larger story that is made up of these individual stories. This is exemplified in an interview we conducted with a Jewish doctor, Dr. Shaul Prawda. When the Germans attacked the Soviet Union, Dr. Prawda was 32 years old, married and expecting his first child. While he was able to speak at length about his attempts to escape and his struggle to survive, his account of the first few weeks after the attack was disjointed. He began his account as follows: *"When the Germans came to A-Stadt (9 second pause), a week later they established a ghetto, that was on June 22, 1941"*<sup>15</sup>.

The narrator broke off his narration here. The process of constructing a story from his memories was too hard for him. Instead, he pulled out some

---

15 Transcription symbols in appendix.

photographs of mass graves excavated after the liberation: *"When the Russians came, they dug them up, they asked me to be present for the record, but I couldn't do it"*.

While we looked through the photographs, Dr. Prawda hesitatingly and indirectly alluded to the fact that the SS had ordered Jewish men to dig graves in a nearby forest. During the first "Aktion", or killing operation, that followed immediately after this, 200 Jews were shot here, and numerous mass killings were committed here until the ghettos were liquidated in October 1942. Dr. Prawda found it very hard to talk about this. His mother and two of his sisters and their families were killed in this forest. He attempted to communicate some of these horrifying scenes to the interviewer, but broke off his narration every time, or departed from the chronology of his life story and confused this period with other phases of his life.

At first glance, the differences between the ease of narration experienced by German accomplices and perpetrators, who were not persecuted, and the narrative difficulties of Holocaust survivors might be characterized in the following way: accomplices and Nazi perpetrators want to talk about the war years and are able to do so, because they are not as traumatized as the survivors, even in cases where they were also confronted with traumatic situations. Although it is impossible to compare the war experiences of accomplices and perpetrators with the suffering endured by Holocaust survivors, it is possible to ask how German accomplices and perpetrators deal with the traumatic situations in their lives. Our analysis (Rosenthal 1990; 1991) clearly demonstrates that the accomplices and perpetrators of the Nazi regime have learned to eradicate all traumatic and embarrassing experiences from their life stories. A German war veteran can talk for hours about being stationed at the Eastern front, just as a German female civilian can give an account of a city that was subjected to daily air raids during the final months of the war. However, not a single dead or dying person appears in any of these accounts. They are often poignant and serve to portray the protagonists as victims of their age, but scenes of horror, fear, or of witnessing the death of others or even the destruction of villages are not elaborated on and are often only implied. This tactic of evading unpleasant scenes holds equally true for experiences that bring up guilt feelings because of the narrator's failure to offer help to people faced with persecution and annihilation. These stories can only be reconstructed, when the threat and emotional anguish they actually entail are eradicated. To block out these tormenting and gruesome experiences, other less threatening stories are often told - "screen stories", as they can be described in reference to Freud's (1899) concept of "screen memories". The narrator generally succeeds in filling in the gaps with stories of experiences that occurred around the same time, and are in keeping with collective narrative rituals. In narrations of World War II, for instance, war anecdotes serve to cover what is being omitted - such as confrontations with death and killing - with something

less problematic. World War II veterans will fill a lengthy narrative about the war with descriptions of military tactics, armaments and vehicles, and details of arriving and withdrawing, and peaceful experiences with civilians.

Narrations of the survivors differ dramatically in this respect. Those, who do talk about the persecution they experienced, set themselves the task of trying to articulate the atrocities and terror. They tend much less to fill in the gaps in their narration with "harmless" stories and seldom use strategies to distance themselves from the horror they experienced. Only one interviewee diverted his story from his traumatic experiences in Auschwitz by telling anecdotes to distance himself and his listeners from what he went through.

In the last few years, many survivors have tried to communicate some of the atrocities they endured to those who did not experience them. It has cost them a great deal of effort to articulate their thoughts, pieced together from fragments of memory. Some survivors have insisted on speaking or writing about their experiences since the liberation: for them, this expression has been the very basis of their continuing survival - Primo Levi is a good example here, while others have chosen silence. But since memories refuse to be erased, finding expression in nightmares and daily anxiety, and since panic reactions can later turn into psychosomatic illnesses, the latter survivors feel a growing need to break their silence. In recent years, many have tried to speak about what they suffered, before their generation becomes incapable of bearing testimony to the persecution.

Many of those, who have begun to speak, who are trying to piece together an exact recollection of the crimes committed against them, suffer from gaps in their memory and can only deal to a limited extent with a stream of narration or with re-living their experiences. These narrative difficulties arise from the trauma they have experienced and from several decades of silence. There were no willing listeners after the liberation, and they did not wish to burden others with what they had gone through; also, they were afraid of being overwhelmed by their feelings if they spoke about their traumatic experiences.

Comparative case analyses of accomplices and victims of National Socialism bring up yet another factor which makes for narrative difficulties on the part of the victims: the partial speechlessness of the victims contrasted with the verbosity of German accomplices and perpetrators is a result of the differing social functions served by addressing the theme of this historical period. Paradoxically, where so-called "witnesses" are concerned, far from serving to expose the injustice of the National Socialist system, its crimes and/or their own implication in them, these narrations attempt to gloss over all of this with other anecdotes. By talking at length about the war years, portrayed as a period of suffering, and by simultaneously playing down the pre-war years and their role as active agents in them, German accomplices and perpetrators manage to avoid the theme of "National Socialism" and their own involvement in this system. By doing so, they succeed in bolstering the

idea that "we suffered a lot, too". This deferral of responsibility puts the narrator's suffering on an equal footing with that of a victim of the Nazi tyranny and forms the basis of their circumventing the theme of Nazi crimes - a crucial element in their narration of war stories.

On the other hand, Holocaust survivors, who have decided to break their silence, want to talk about their traumatic experiences in a response to the tendency to forget Nazi crimes and to the thesis of the "Auschwitz lie". And so they try to articulate very traumatic experiences that are the hardest to relate. While German accomplices and perpetrators try to gloss over these atrocities with anecdotes, survivors' attempts are geared towards bringing these atrocities to light. They want to make a testimony, to use their personal experiences to prove the kind of unspeakable cruelties that were committed in Europe by the Nazis and their accomplices. In the process, they are often faced with the problem of uncovering and recounting something so intensely traumatic that it seems impossible to express or include in a narration. Of the atrocities they experienced, the ones they suffered on a daily basis seem to stand out most: situations that had become routine - daily humiliation and mortification, the death of fellow-inmates, roll calls, not being able to wash, hunger and cold. Thus, Holocaust survivors are imposing an almost impossible task on themselves: that of relating experiences that were so traumatic that it is very hard to tell them, meaning that before this narration, they had not been constructed into stories. Survivors need help during the process of constructing stories in the form of a supportive listener, if they are to be able to construct a narrative of their lives during persecution.

It is the author's experience that this kind of active support not only helps survivors to articulate their experiences, but that their doing so marks the beginning of a healing process as well (cf. Rosenthal 1995a, p. 167-185). The seeming impossibility of recounting these experiences leads to the danger of the individual remaining entangled in the past, incapable of distancing themselves from it. This also makes it impossible for them to experience the past as distinct from the present. In this sense, the narrative represents a transformation from the unknown to the known, in which the unfamiliar becomes recognizable and comprehensible to both narrator and listener (Schütze 1976). In contrast, if the biographers cannot communicate their suffering, they tend to get little empathy from those who do not share their experiences or have never suffered anything similar themselves. It is my opinion that an inability to talk about traumatic experiences leads to a second traumatization after the actual suffering is over. The inability to turn experiences into narration - life history into life story - leads to a consolidation of the trauma accompanying the original experiences. This is not to say that there are not survivors who have to protect themselves from recounting their experiences, as to do so would present too great a risk for them. These survivors would either refuse to take part in an interview or would use narrative techniques to avoid

telling their stories. We can assume that survivors, who are capable of successfully living their daily lives and not being completely oppressed by their past, have enough strength and competence - presumably more than other people - to protect themselves in an interview from interventions that go too deep. Wolfram Fischer-Rosenthal (1992) speaks of a man who, rather than telling the story of the persecution he had experienced, asked the interviewer to inform himself about this phase of his life by reading his biography, which his wife had written based on documents from his psychotherapy sessions. He added that he himself only wished to speak about the period after the liberation.

### Different types of fragmentary life stories

Interviews with survivors of the Holocaust illustrate, how persecution - the physical and psychological disruption of their environment and of parts of themselves - has destroyed their sense of continuity for any sustained period of time. Their life stories are presented in a disjointed and fragmented way. The individual phases of their lives - the period before and during the persecution, as well as the period that followed their survival of it - can only be pieced together with considerable difficulty. Similarly, the connections between the individual experiences within these periods are often very disjointed. In addition, entire periods of their lives are lost in speechlessness, and the biographers can only recall them as individual fragments, images and emotions.

Some survivors are barely able to present their recollections of the period of persecution in story form<sup>16</sup>. They use the following narrative structure to solve the problem of speechlessness: they tell the story of the persecution before their arrival in the extermination camp, leave out the time in the camp, and resume their narration after the liberation. An Auschwitz survivor from Jerusalem, Mrs. Silbermann, provides an example of this strategy. She gave a detail account of three extremely hard years she spent in the ghetto, during which time her entire family was murdered, with the exception of her mother. She spoke briefly of having arrived at Auschwitz with her mother in the summer of 1944 and then immediately shifted the time frame to the end of her time in the camp. She then continued with a detailed description of the reason

---

16 While these cases are described as the "rule" in the literature of psychiatry (cf. Eissler 1963; 1968), in our interviews they form the exception. This is due to the fact that we did not interview people undergoing psychiatric treatment and our interviewees were all volunteers. Most survivors however, who took part in amnesic interviews with psychiatrists, did so to aid the diagnosis of "persecution-related damage" as part of what are known as West German indemnification methods. In these interviews, psychiatrists had to evaluate, whether the victims' present-day illness and physical and/or emotional damage was caused by Nazi persecution (cf. Niederland 1968).

for her survival: she said that she had survived because she wanted to die. In January 1945, shortly before the SS evacuated the camp and all the inmates, apart from the seriously ill, her mother was taken to the infirmary. In extermination camps, this usually meant certain death. After repeated, persistent attempts, Mrs. Silbermann managed to get inside the revier: she wanted to die with her mother. This meant that mother and daughter were not sent on the "death march", which in their weakened physical condition they would have been very unlikely to survive. Instead, they were liberated by the Red Army. Temporally, the narrative structure of Mrs. Silbermann's life story ends with an account of her being transported in a cattle car in inhuman conditions for fourteen days. The seventeen-year-old, as she was at the time, disappears as the agent in her life story at this point. Presumably she was totally dependent on her mother at the time and only recovers agency when she is left to fend for herself without her mother. In my interview with Mrs. Silbermann, I tried several times to bring her to speak about the period she spent in Auschwitz, but to no avail. She was only able to only respond with such images as "the inmates all looked mentally ill" or "Auschwitz was a lunatic asylum" and could not manage to tell any stories. The time she spent in the camp has lost all chronology; it has been reduced to an asynchronous structure that can only be recounted as one overall impression, without the individual elements or experiences that comprise this impression. The impression of a lunatic asylum presumably expresses her self-image at the time. When I met with Mrs. Silbermann again, a year later in February 1991 during the Gulf War, the reason that stories of Auschwitz had not been forthcoming despite my encouragement became acutely apparent. In response to my question as to how she felt, sitting in a sealed room during the Iraqi air raids, she said: *"I feel like I did during the Aktionen in the ghetto. I feel this awful, paralysing fear, this pain in my stomach. After the all-clear, I feel completely empty, completely weak and paralysed - like in the ghetto."*

She replied to my question, *"Do you feel like you're in Auschwitz again?"*, in the negative: *"No, I don't think about that, 'cause I was practically dead then, I didn't feel anything any more."*

For Mrs. Silbermann, being practically dead, completely numb already a "Muselmann", meant a total lack of agency and future perspectives. As an inmate, she drifted, functioned like a machine going through life in the camp, passively subjected to the traumatic routines there, such as the roll calls. And in the process, she increasingly disappeared from her own life story as the agent and could barely recount it later. This contrasts with the life stories of survivors who did not renounce themselves, but fought with all the cunning and deceit they could muster to survive, who were not condemned to total passiveness because of the specific situations they were in; people who were cooped up in cramped hiding places, for instance. These survivors can talk at great length and in great detail about their experiences, in some cases even

becoming obsessive. Mrs. Silbermann can relate her "liberation history" in detail: she had committed herself to something, stirred herself into action and managed to get into the revier despite resistance from the physicians.

Apart from these difficulties in telling the story of the period of persecution - which are well-documented in the literature on the Shoah and its impact (cf. Eissler 1963; Niederland 1980) - a comparison of life stories also shows that the experience of persecution can cause a loss in the chronology of the period before and after it. These specific experiences contribute to whether biographers can:

- a) barely talk about the period before the persecution, or
- b) barely talk about the time after the persecution, or
- c) only talk about the period of persecution itself.

Mrs. Weiss (born in 1934) belongs to the group who are barely able to relate the part of their lives before their arrival in Auschwitz. At the beginning of her life story, she only mentioned her parents' professions, how many siblings she had and that she had been in a ghetto for a little while. Then she began a detailed account of being transported to Auschwitz, of the circumstances surrounding her separation from her mother on the ramp and, together with her twin sister, of being one of Mengele's "guinea pigs".

During the questioning part of the interview, I repeatedly tried to encourage her - with no success - to tell me more about her childhood before Auschwitz. The interview was conducted in English. Mrs. Weiss' language of habitual use is Hebrew (she no longer speaks her native language, which is Hungarian). My first question, following the main narration of her life story, was: *"What can you remember about the time before the war?"* She answered: *"About the time before the war, uh-, you was, uh, you are- uh very- (2) uh- (2) happy family"* Her husband intervened: *"We was, we was"* Mrs. Weiss: *"We was a very, a very happy family, eh-, and-, eh- (2 seconds) very rich family."*

Her confusing 'we' and 'you' was not the result of a poor command of English. Rather, it is our first indication that she has "lost" the story of her life before Auschwitz. Interestingly enough, Mrs. Weiss used the first person plural in her narration - the appropriate pronoun - until she was brutally separated from her mother upon their arrival at Auschwitz. During the course of her narration about her time in Auschwitz-Birkenau, where she was sent with her twin sister while her parents and two elder sisters were killed in the gas chambers as soon as they arrived, she dropped the "we" that was destroyed for ever at that time. Mrs. Weiss was ten years old when she arrived at Auschwitz; her childhood has shrunk to nothing more than the label of a happy family and a few photographs, in particular, a sweet reproduction of herself and her twin sister as children, which she gave me as a present. Her childhood was brutally cut short once and for all, when the SS men tore her

and her sister away from their mother, because the twins were selected to "live" for medical experiments. This break is manifest in her biographical self-presentation as well. The first story she recounted in her life story clearly indicates the caesura in her life:

*"In this moment we came from the wagon some German were crying "Zwillinge heraus, Zwillinge" ("twins get out") and they take my sister and me from my mother in a place are making numbers on the arm. I remember that you don't want, eh give him my hand to make a number, you are CRY-ING (very loud) you want my mummy and then some people was speaking Hungarian, they told that tomorrow you are seeing all the family and then I give him the hand to make the number."*

While all my inquiries about the time before Auschwitz only led to brief accounts or to argumentation, those pertaining to her arrival in Auschwitz evoke a clear narration. It seems unmistakably clear on the basis of this text structure, that the moment of her separation from her mother represents the "threshold of the present" (Fischer 1982) in her life story. This seems to signal the turning point that separates her past from her present.

Unlike Mrs. Silbermann, Mrs. Weiss was able to give an account of her time in Auschwitz-Birkenau. She talked about the experiments that she and her sister were subjected to, about how her sister fell ill because of the injections the Nazi doctors gave her, and about her tireless search for her mother which even led her to look through the piles of corpses. Mrs. Weiss' time in Auschwitz has not shrunk to a timeless image, because even though she was only ten years old at the time, she fought actively to survive. While Mrs. Silbermann lost her will to live, in Mrs. Weiss' case, her own survival was the only guarantee for that of her sister. If she had failed to withstand the various cruel experiments conducted on her by Dr. Mengele, her sister would certainly have been murdered and vice versa.

It could be argued that Mrs. Weiss cannot tell the story of her childhood, because she was only ten years old when she came to Auschwitz, and that this is why her recollections are unclear. But there are other cases of much older survivors, where the same phenomenon emerges, as is discussed in the literature on the subject (cf. Grubrich-Simitis 1979): it is quite clear that these blanks are usually connected to an overly defined memory of the persecution. All the survivors involved in our study, who are unable to tell the parts of their life story relating to the time prior to the persecution, have lived for long periods under very extreme circumstances in extermination camps as opposed to in concentration camps or forced-labour camps. They differ from those who are able to talk about their life before the persecution, in that they lost everything they had before the war. They lost not only their family, country, language, and belongings, but also all their plans for the future, incipient ca-



reers, hope, belief in God<sup>17</sup> and belief in themselves as well. In other words, their lifeline before the Shoah was abruptly and irreversibly severed by the persecution (cf. Niederland 1980, p. 229). The period prior to the persecution is no longer part of their life story, that is, it cannot be integrated into it. The destruction effected by the Holocaust was so all-encompassing that it becomes impossible to find connections to any part of one's former life, whether professional or personal. Formulated in the language of Gestalt theory this reads: the shape of life before the persecution cannot be integrated into the shape after persecution. No lines of connection exist to the life before the persecution. Moreover, this type of survivor tends to idealize the time before Auschwitz and to condense it into a single image - "We were a happy family". It may be assumed that these survivors already idealized their family during their time in the camps, as is illustrated in the psychological literature, where this is discussed as a coping strategy (cf. Matussek 1971). The idealization may be another reason for the survivor's reluctance to go into details about the pre-war period, since such investigation might endanger this idealization.

Another reason, that speaks for the above interpretation of the loss of life history before the persecution and the destruction of all continuity, is the fact that those, who can talk about the period prior to the persecution, extend these biographical strands to the period after the war in their narration of them. Thus, for example, another survivor who was in Auschwitz and lost her parents, her sister and her husband there, focuses her narrative on her education - a biographical strand that she can pick up again after 1945. Other strands, however, such as her marriage, are simply added on by way of the relevant dates.

Furthermore, as seen in their narratives about the pre- and post-persecution periods, the life story of these survivors is only told within the framework of the Holocaust. In other words, they refrain from telling parts of their life history that do not fit into the main theme of persecution. The biographical strands, that they do not see as belonging within this framework, are lost. The structuring principle of these narrations, their thematic field, as Aron Gurwitsch calls it (1964), is the persecution itself. The individual stories are embedded in this thematic field. This field is defined differently by the various biographers: sometimes by the recurrent question of why they did not emigrate; or why they did not try to combat anti-Semitism before the war. In the case of those who migrated in time, the question of why they left their parents behind seems to be of primary importance. For example, Amalia Teschner (born in 1916), a survivor from Slovakia, whose thematic field in her life story rests on the question of why she did not emigrate, despite having

---

17 Mrs. Weiss, for example, came from an orthodox family who were strictly kosher. Like many other survivors, she claims to have lost her faith in God in Auschwitz. And since she could not keep any kosher rules there at all, the entire thing failed to make any sense to her after a while.

an opportunity to do so, responded to my request for more details of her childhood and youth with accounts that were embedded in this thematic field. She spoke of her good relations with her gentile neighbours and friends and about the general absence of anti-Semitism in her hometown. Her stories seemed intended to prove that she had not realized that leaving Slovakia was necessary.

When I asked: "*Maybe you could tell me more about your parental home?*", she replied: "*My parent's home, my parents were religious Jews. As I mentioned, we were six children. I was the second. We lived in a small town ... and we had a wonderful youth. Maybe we were blind. I don't know. Maybe we didn't want to see. As children, as a child, we (I) didn't know what anti-Semitism was.*"

The phenomenon of the impact on narration of the pre-war period of the Holocaust and the different problems, that go along with it, also makes itself felt in relation to the post-war period. As mentioned earlier, these life stories are related entirely to the thematic field of the persecution. Thus, for example, Mrs. Weiss, quoted above, was able to talk about her life after the liberation; the story of her illnesses, that were the result of her time in the camp and the experiments carried out on her by Mengele and his physicians.

The question then is, how do these differ from other life stories? Generally when analysing a narrated life story, one finds a main theme that functions as a structuring principle for the entire biography, as shown for instance in the reconstruction of an interview with a daughter of a perpetrator (Rosenthal/Bar-On 1992). This woman recounted her entire life in situations where she was invariably the victim while the main perpetrator was her own father. The difference between her story and interviews of Holocaust survivors lies in the ability of those, who did not suffer persecution, to change this underlying thematic field in the course of an interview. Sometimes biographers who were not traumatized, have more than one central theme in their main narration, or else they change this central theme in response to the interviewer's questions. They are also able to narrate their life stories along varying central themes in different situations. It is therefore my assumption that, even in different contexts, Holocaust survivors are generally only able to tell their life stories within the thematic field of the persecution. In my opinion, this represents a real opportunity for the listener to provide effective support; namely, in helping them to construct experiences that are not in the thematic field of the persecution. This also means giving them back their future and with it their present. Just as biographical narration of the persecution can have a healing effect, reclaiming the parts of their life story, that come before and after it, and embedding these phases in thematic fields not connected to the persecution, is also of crucial significance for living with this past more easily. What emerges not only from interviews with Holocaust survivors but also from those with other people who have suffered trauma, is that a precondition

for these processes of integration is the necessity of getting these traumatized people to talk about their entire life story and supporting them in this exercise. When confronted with a request to tell only the story of their lives during the period of persecution, interviewees tend to lose their grasp of the other phases of their lives, and to re-centre their lives around the experience of survival. On the other hand, if they succeed in reconstructing their lives after the persecution within the framework of other thematic fields and in reclaiming traces of lived continuities with their life stories prior to the persecution, they will have taken the first steps towards an easier relationship with their pasts.

### *Five Families of Survivors of the Shoah*

In the section below, we consider five survivor families from the point of view of the impact on the children's and grandchildren's generation of the fragmented life stories their grandparents tell them, and of the parts of their past that they refrain from talking about. The families we present in this part differ considerably in terms of their experiences of persecution, their family histories after the liberation, and the way they deal with the past.

In the Kovacs and Kubiak families, we focus on the lives of the second and third generation in Germany. Both the sons in the Kubiak family and the daughter in the Kovacs family are married to non-Jewish German partners. Using Miriam, the Kovacs daughter, as an example, we try to illustrate a mechanism found in other daughters and sons of survivors who choose partners who embody the aspects of themselves that they have split off. A number of children of survivors have always suppressed their own aggressions. An aggressive partner can vicariously express their suppressed aggression for them; in some cases it is even directed at them. In the case of this couple, Miriam and Achim, it emerges that Achim voices the accusations against his parents-in-law that Miriam has presumably had to suppress her entire life. In the Kubiak family, we present a family history of persecution in Poland followed by migration to Israel and then, in 1961, to former East Germany. Here, we are dealing with a family secret pertaining to the family's migration from Israel to East Germany. Like many other second-generation survivors, both sons in this family suffer, because they live in the land of the perpetrators - a life imposed on them by their parents - but are unable to attack their mother openly for making them come to live in Germany. The grandchildren in this family have considerable problems living in Germany, too, and one has already emigrated to Canada.

The Goldstern family illustrates the tremendous impact that a collective history - the history of the Lodz ghetto -, bound up with the traumatic experiences suffered by the grandparents, can have on their children and grandchildren. By developing phobias and self-destructive tendencies, the grandson in

this family acts out the family past that has been passed on to him at an unconscious level. His father, on the other hand, tries to keep the past out even more, putting up an emotional wall around himself in the process. The Sneider family gives us an opportunity to examine the problems that prevail in a family in which the grandfather and grandmother survived as inmate-functionaries. There are considerable differences in these two families in terms of their family dialogue, the myths they create, and the family secrets linked to these myths. Whereas the Goldsterns represent a family who have created a myth focusing on the parts of their family history that involve fighting, and who remain silent about experiences involving powerlessness and helplessness, the persecution in the Sneider's past required the creation of a different myth. This family has established a myth that the grandparents are perfectly ordinary survivors, while the theme of forced collaboration hardly features in the family dialogue at all.

The Stern family from Israel illustrates the impact on the second and third generations of different family pasts being combined by marriage where the non-Jewish family past is blocked out of the family dialogue. The mother in this family is a child-survivor of the Shoah. Her son provides an example of how generational boundaries can be blurred and how children born after the Shoah try, in the words of Auerhahn and Prelinger (1983, p. 33): "to re-enact the experience of trauma via an activation in fantasy so as to understand the parent and the present familial atmosphere".

In the Goldstern, Shapiro/Sneider and Genzor/Kovacs families, we had the opportunity to interview siblings of the grandparents' generation. While all three of the sisters we interviewed in the Genzor family survived the ghetto, Auschwitz and the Stutthof concentration camp, they survived under very different conditions in different concentration and death camps. The shared experience of having survived has led to a lifelong bond between the Genzor sisters, but also to them controlling what each other reveal about the past. The dialogue between the sisters in the Shapiro family revolves primarily around the question of who suffered most. In the Goldstern family, two of Amos Goldstern's sisters lived with the family in the Lodz ghetto until 1944. Amos, who left in 1940, always tries to evade his sisters' memories of the family's suffering in the ghetto, but keeps being confronted with it non-verbally by his wife, who was also in the Lodz ghetto until 1944.

Like in many other of the families we interviewed, in three of the families depicted here there are indications that the grandmothers experienced sexual violence: many survivors were raped by Germans and then after the liberation by Soviet soldiers and were forced to have sexual relationships with female guards, *Wehrmacht* soldiers, doctors in Auschwitz and concentration camp inmates. It is only in the past few years that Holocaust studies has addressed this violence inflicted on women (cf. Ringelheim 1994). It is our opinion as researchers that our methods of eliciting narration about such experiences and

of evaluating hints of sexual violence in interviews are still very much in their infancy. Again and again, the women in the interviews we conducted dropped unmistakable hints of sexual violence, or addressed the theme of experiences they had gone through themselves by telling stories of what had happened to other women who had experienced the same thing. But our female interviewees did not explicitly talk about their own experiences of violence. We are forced to admit here that our interviewing method may fall short when it comes to uncovering these experiences, which are linked for these women-survivors with a great deal of shame and guilt. To what degree a more directive interviewing method involving direct questions about this theme could help women to verbalize their experiences requires further investigation.

The hints in our interviews only permit us to make valid indications of sexual violence in our analyses of the interviews in a limited way. But we feel a responsibility nonetheless to draw attention to these hints so as not to perpetuate the taboo placed on this theme.

As in many other of the families we interviewed (cf. Gilad 1995), it becomes apparent in the marriages of the Sneider, Goldstern and Kovacs grandparents that one partner tends to do most of the talking about the past, while the other tends to remain silent. The partner, who remains silent, suffers without being able to express their traumatic experiences in words: this suffering takes the form of clearly psychosomatic symptoms, nightmares, nervous breakdowns and depression. Based on her therapeutic experience, Yael Danieli (1982, p. 408) states that in families in which both parents are survivors of the Shoah, it is often the one who suffered more who does not speak about the past. I, however, would not like to speak of greater or lesser suffering, but rather of different suffering. Thus, my empirical analyses suggest that the amount of scope for agency in the persecution situation is one of the decisive conditions for being able to talk about traumatic phases of life (cf. Rosenthal 1995c). This emerges very clearly in the case of Rebecca Sneider, who takes on the role of the one who does the talking in both the dialogue with her husband and with her sisters. We will go into the dynamics of the allocation of roles in greater detail when we examine the family dialogue within the Goldstern family (cf. Chapter 6.1).

Where there is a constellation of one parent or grandparent who talks about the past and one who remains silent, it becomes very apparent that the fantasies and symptoms, that develop in the second and third generation, are more closely linked to the past of the silent one than to that of the one who talks about their experiences. Their descendants either use fantasies to fill in the gaps of stories that are not told, or they put a great deal of energy into denying the past that they can sense is there. Like the parts of the family history that are not discussed, the parts that are denied have an impact on the biographer's own life history, too, without them being aware of it. In this respect, it makes no initial difference whether the children and grandchildren

are in Israel, in West Germany or in East Germany. Even Israel's future-oriented society and the children's and grandchildren's orientation on the image of the Sabra, who lives and fights to build Israel, cannot lessen the impact of the past on the present. Rather, the children and grandchildren of survivors in Israel - as Ronit Lentin (1996) puts it referring to second-generation women - live in the tension between this image of the fighting and future oriented Sabra and the shadow of the persecution in their parents' past. As the sons and grandsons of the Goldstern and Stern families illustrate, male Israelis are confronted with their own role as soldiers, unlike their second and third generation counterparts in Germany. Particularly the war in Lebanon and Israeli policy in the occupied territories have led to the sons, and even more so the grandsons, of survivors asking themselves the painful question of to what extent they themselves could become or have had to become "perpetrators". The extent to which they are preoccupied with questions pertaining to their guilt and compare themselves to Nazis becomes apparent in both of these families. In the case of the daughter in the Sneider family, we see how, as a woman, this orientation on the future is expressed in her life as a strong orientation on success in her career.

The strong bond that the second generation feels to the generation of their survivor-parents emerges very clearly in all five families. This is strikingly manifest in the biographical self-presentations of the children's generation: their own life history either virtually disappears behind the family history or is textually linked to the persecution in their parents' past. Here, life stories of the children of survivors differ considerably from members of the second generation of forced emigrants (cf. Part 3), who have a tendency to present their biographies as detached from their parents' biographies and family history. It becomes especially apparent in the fantasies and dreams of children and grandchildren of survivors how close the persecution feels to them. These often contain scenes where they are being persecuted themselves; they often visualize themselves with their relatives in the ghettos, concentration and death camps, or in other persecution situations. A phenomenon predominantly observed in firstborn children of survivors is that of locating themselves in the past and not being able to distinguish between past and present. In both the Goldstern and Kubiak families, the younger son has managed to put somewhat more distance between himself and the persecution in his parents' past, feels less rooted in this past himself and as a result can speak more freely about it than the elder son. In this way the younger children resemble those members of the third generation who are able to distance themselves somewhat from the persecution by confronting it verbally, as opposed to those who act it out more through psychological or psychosomatic symptoms.

Members of the third generation also have a symbiotic attachment to their parents. Thus, they are struggling for both greater autonomy from their parents and for more distance to the persecution in their grandparents' past. In

some cases, the grandchildren of survivors experience their parents in the parenting role in relation to their grandparents and themselves in the parenting role in relation to their parents. In other words, while the second generation "parent" the grandparents, they also have a tendency towards parentifying their children by imposing the caretaking role on them. The difference, that can be observed here between the second and third generation, is that while the parents can hardly even complain about parenting the grandparents, the grandchildren openly rebel against this role imposed on them by their parents. While the grandchildren have grown up in a financially and socially more sheltered milieu than their parents, and have more temporal distance from the Shoah as well (cf. Bar-On 1995, p. 344), the family dynamics, in which the grandparents' persecution plays a major role, are still quite complex and difficult for them, too, as we will see below.





## 5. Surviving together and living apart in Israel and West Germany: The Genzor family

Gabriele Rosenthal, Petra Jordans and Bettina Völter

*Three sisters who support each other through the persecution: Irina, Sarah, and Tamara*

Irina (born in 1924), Sarah (born in 1926) and Tamara (born in 1928)<sup>18</sup> are daughters of the orthodox Jewish family Genzor in Oradea, a town in northern Transylvania. Oradea was the second largest Jewish community in Hungary. In 1941, 21,337 Jews lived there, making up 22.9% of the population (Encyclopedia 1995:1066). Until 1919/1920, Oradea belonged to Hungary. Their father David Genzor served in the Austro-Hungarian army in World War I. After the war, Rumania annexed northern Transylvania and in 1940, it was ceded to Hungary. After the Second World War, it became Rumanian again. These changes of sovereignty influenced the course of the persecution of the Genzors. The family of Viola, the mother, and her parents and sisters with their families lived in Carpatho-Ukraine, a region which had also been part of Austro-Hungary until 1919/1920 and then became part of Czechoslovakia. In March 1939, it was annexed by Hungary. The massive persecution of the Jewish population began in both these regions, when the Germans occupied Hungary in March 1944. The Genzor family was forced to move to the Oradea ghetto, which housed some twenty thousand Jews until May of that year. The entire family was sent to Auschwitz in June 1944, except for one brother who was in a forced-labour camp. As soon as they arrived at the Auschwitz ramp, the SS separated Irina, Sarah, and Tamara from their parents and two younger siblings, Benjamin and Hannah. The three sisters survived the persecution together, in the Auschwitz-Birkenau death camp, a sub-camp of the Kaiserwald camp near Riga, and the Stutthof death camp near Danzig.

They and their older brother Jacob were the only members of the family to survive the Holocaust. Their maternal grandparents and the families of their aunts were killed in Eastern Galicia. Jacob is now dead. Irina lives in West Germany, Sarah spends the winter in Israel and the summer months in West Germany. Tamara lived in Israel and died in 1995.

---

18 Irina was interviewed in Germany twice by Gabriele Rosenthal and Bettina Völter in German. Bettina Völter interviewed Sarah twice in 1994 in German in Israel. Tamara was interviewed in Hebrew by Yael Moore in 1995 in Israel.

## History of the family before the deportation

In the period before they entered the ghetto in 1944, each sister experienced the years of persecution differently. Their accounts of those years contradict each other on many points. Irina's fragmented account of the family past and her biography made it particularly hard to reconstruct the chronology. She rarely talked about what happened in chronological order. The time before she reached Auschwitz figured mainly as background information for the time thereafter. The structure of the interview text reveals that the 'selection' in Auschwitz represented the 'threshold of the present' for Irina (cf. Fischer 1982), which divides the present from the past. While she talked more about the time after she crossed this threshold, her sister Tamara spoke more about the time before Auschwitz: *"They took us to Auschwitz and that meant the end of everything. That's what it is. That is my past, in Auschwitz when we got out of the trains."* There are issues concerning the sisters' lives before 1944, that are very painful and have become taboo in their dialogue.

All three sisters pointed out that they each see the past differently. The crucial differences have to do with their experiences in Auschwitz. Sarah began her interview with the comment that her memories differ from those of her sisters, although they experienced the same thing in the concentration camp. Tamara, the youngest sister, went so far as to say they could not all be children of the same parents because their characters were so different. Tamara is the one who repeatedly threatens the harmony among the three sisters. She has a particularly bad relationship with the oldest, Irina.

The lives of the three sisters began to diverge in 1938, when the family was divided for the first time. Their oldest brother moved to Bucharest to learn a trade. The fourteen-year-old Irina went to visit her maternal grandparents in Carpatho-Ukraine in August 1938. While she was there, the border between Slovakia and Rumania was closed.<sup>19</sup> Irina, her grandparents, and the families of her aunts and uncles were cut off from the Genzor family in Transylvania. Irina was only able to return to her parents two years later, after Hungary seized both regions and the borders came down. The separation from her parents also marked the premature end of Irit's schooling. But as her detailed stories about those years showed, Irit, who had grown up with four younger brothers and sisters, loved living with her grandparents and enjoyed their attention.

Just as Irina returned to her family, the phase of intense persecution began. Irina scarcely talked about it in the interview. Her sisters told us that, after she came home, the Hungarian authorities suspected her of being a spy. She and her father were summoned to the secret police and interrogated. Then

---

19 The border between Slovakia and Rumania was closed in 1938 because of the Munich Conference and the annexation of Bohemia and Moravia by Germany and the establishment of an independent Slovak state, which collaborated with Nazi Germany.

the whole family was arrested and taken to prison in Budapest. A few days later, the mother Viola and the five children were released from prison but interned. The father was sent to a forced-labour camp. Irina also briefly mentioned this time in jail but said it was because their Hungarian citizenship was not recognized and that their mother had the greatest difficulties because she was from Carpatho-Ukraine. She said they were released after a few months on the strength of a guarantee and went home to Oradea.

In Budapest, the mother felt overwhelmed without her husband and alone with her three younger children. She put Tamara in an orphanage. For Tamara, who was twelve at the time, this separation was one of the greatest disappointments of her life. It featured much more prominently in the interview than all the subsequent torments. The children in the orphanage were all assigned foster-parents who took them home for the weekends. The elderly childless Jewish couple, who looked after Tamara, gave her all their love. Tamara likes to recall their outings and visits to the theatre. She spoke very positively about those years. Tamara enjoyed being her foster-parents' only child, just as Irina enjoyed being alone with her grandparents. Tamara said she had always felt disadvantaged in her own family as one of the children in the middle; her parents had never had much time for her. Tamara went back to her family when she was sixteen in early 1944. It was painful to leave her foster-parents. She assumes they did not survive the persecution. After the liberation, she went to look for them but found their house in ruins.

The Genzor family was forced to move to the ghetto in the spring of 1944. The father had been released from a forced-labour camp in 1942. It is not clear, how long the mother and the children spent in internment in Budapest or when they went home to Oradea. The three sisters' accounts contradict each other. Irina says they were released after just three months. We believe that the time Tamara lived apart from the family is one of the themes that are taboo in the sisters' dialogue with each other. Were they to talk about when exactly their mother and the children left Budapest - whether it really was as early as 1940 -, Tamara would probably feel even more acutely that she had been abandoned by her family.

Contact with the mother's family was interrupted in 1941. The maternal grandparents, aunts and their families were expelled from Carpatho-Ukraine and sent to Stanislawow in Eastern Galicia. Entire communities were driven out of Carpatho-Ukraine under the pretext that they were "alien nationals" and were murdered by the SS in Eastern Galicia (cf. Encyclopedia 1993, p. 1420f). Irina talked at length about this part of the family, and everything she heard after the war about their fate. She feels very attached to the grandparents and feels guilty about having left them in 1940.

## Surviving the death camps

In early June 1944, the Genzor family was deported to Auschwitz. From then on, the three sisters were together until the liberation. They supported each other and survived many dangerous situations and serious illnesses because they helped each other. In this constellation, Irit took on the role of "mother" and looked after her younger sisters. Sarah adopted the role of "the beauty" in the sisterly triad. In the interview, she described Irina as "the clever one": *"We always listened to my big sister; what she said we accepted without question."* Tamara took on the role of the "little daughter". Sarah said: *"With the little sister I am like a mother with her daughter. We ((Sarah and Irina)) were the grown-ups and it's stayed that way ever since."* While Irina and Sarah remained in close contact after the liberation, Tamara was always somewhat more distanced. While Sarah continued to look after Tamara, the contact between Irina and Tamara was not very close. Irina and Sarah both told us several times that Tamara was not able to remember, what happened properly, and mixed everything up because at the time, she was just a child.

During the time they spent together in the concentration camp, they may well have had experiences that they would rather not talk about or would rather conceal – especially the two older sisters. For all three, the separation from the other members of their family at the ramp in Auschwitz marked the "threshold of the present", which irrevocably separated them from their earlier life. While many Polish Jews had witnessed killings by the German army and then by the SS mobile killing units (*Einsatzgruppen*) since the very beginning of the war and long before they themselves were sent to Auschwitz, the three sisters had hardly seen anything comparable in Hungary. During their weeks in the ghetto, they suffered hunger and the quarters were very crowded, but nothing they had experienced until then prepared them for what they would face after they arrived at Birkenau.

Irina talked about their arrival at the Auschwitz ramp: they saw a baby torn away from its mother who was then savaged by dogs. Tamara said she watched as a baby was thrown to the dogs and killed. Years later, she is still plagued by nightmares in which dogs are set on her. In the interview, Sarah recalled a scene at one of the first roll-calls in Birkenau. A child was taken away from its mother; the mother tried to resist and was shot by an SS man. This scene still haunts Sarah in her dreams: *"It is so vivid (2) she (1) is crawling on her knees to her daughter she wants to go to where her daughter (1) and they shoot her. I watched too closely, the woman, how she crawled to her child"*

Sarah hears the shot of the revolver and wakes up at once, before she catches sight of the dead mother. The day after she told this story to the interviewer, Sarah called her to say that the same night, after their meeting, she dreamed the dream to the end: she saw the mother lying there dead and she

felt relieved, that the woman could at long last meet her death in her dream. Of the three sisters, only Sarah imagines what it is like to die in a gas chamber, with the adults standing on the children to get more air. She said that she and her sisters once had to clean the crematorium in Stutthof.

After a month in Auschwitz, the sisters were sent to Krottingen, a sub-camp of the Kaiserwald concentration camp near Riga in Latvia. They worked there in the military (*Wehrmacht*) uniform workshop. In the summer of 1944, the Soviet Army was getting closer and the SS started to kill large numbers of inmates and to send others away to other camps. In August, the sisters arrived at the Stutthof concentration camp, where they suffered the most. In the interview, Irina said again and again that Stutthof was even worse than Auschwitz-Birkenau. A typhoid epidemic broke out that winter (cf. Skutnik 1979, p. 14). She can still remember the piles of corpses. Irina recalls: *"The gas chambers were broken in Stutthof and they piled up the corpses behind the block like wood. The corpses were swollen and the pile grew and stank."* Then a pyre was built and the corpses were burned.

In Stutthof, the three sisters again had to work for the German army (*Wehrmacht*) in the uniform workshop. Male inmates with better jobs in the camp used to buy sex from female inmates. Sarah was eighteen at the time, she was given presents and was expected to offer something in return. She says she always managed to avoid fulfilling such demands and left the camp a virgin.

The theme of prostitution and sexual violence in the camps recurred throughout the interviews with the three sisters. They also talked repeatedly about one of the most cruel of the female guards, who was in love with Sarah and for whom Sarah worked as a maid. Sarah's job meant improved living conditions for all three sisters. Sarah said she was frightened of the guard's sexual wishes and stressed that most of the female guards were lesbians. Sarah also talked about a brothel in which female inmates were forced to submit to sex with German *Wehrmacht* soldiers. In her account, Irina focused more on the male prisoners who offered food in exchange for sex. Irina said Sarah was *"an attractive young girl and she was very skilled she kept everything clean there ((in the home of the SS guard))."* Irina also said she helped Sarah maintain her appearance and make the most of her beauty. Irina saw it as a way to get gifts from male prisoners. She saw herself in the role of mother, as the following slip of the tongue made clear: *"And my daughter, my daughter- oh, my sister"*. Irina wanted to tell us about Sarah's success and thereby unintentionally indicated that she too attracted men's attention: *"After a while one of these engineers approached me and slipped her something."* Irina said that both she and Sarah were so naive back then and thought: *"My god, he wants to put his arms around you or kiss you and for that you can make a little sacrifice to survive."*

Irina talked repeatedly about the sexual demands of the prisoners in the camp. She made a point of stating explicitly, however, that she could not have imagined having a sexual relationship there. Irina is also the one sister who mentioned Soviet soldiers raping women survivors after the liberation. But here too, we could not establish whether she or either of her sisters was actually raped. In their interviews, Sarah and Irina hinted that their younger sister Tamara improved their living conditions for a while through prostitution. While Tamara did not address the issue, her daughter Viola<sup>20</sup> did. When the interviewer asked, if her mother had told her herself, Viola answered that Tamara had always approached the issue by telling stories about other women in the camp, never about herself. Tamara was at any rate the one who was always able to "organize" some food. Once, a German army officer saw Tamara slip Irina something to eat and threw a piece of wood at Irina. It hit her in the face and injured her. She has suffered from severe headaches ever since. It was not until the mid-seventies, that an X-ray revealed a splinter of bone, which was then surgically removed.

Sarah became ill with tuberculosis in Stutthof, and the lymph glands on her neck swelled up. She was operated on without anaesthetic. She said the doctors tortured her by cutting open the same swelling again and again in order to find out how long she could endure the excruciating pain. Tamara mentioned that injections were given in Stutthof and talked about being beaten. Once, a female Kapo beat her twenty-five times with a stick on the back, because she had shifted from one leg to the other at a roll-call because of the cold.

Stutthof was evacuated in mid-February 1945. It was the middle of winter, and the inmates were forced to march towards the west. Many died on the way. The sisters were liberated by the Soviet Army on March 13 1945. Irina and Sarah contracted typhoid and after several weeks in hospital, they set off on foot and then by train for Oradea. Of the 35,000 Jews who had been deported from their hometown, 5000 came back (Rosh/Jäckel 1990, p. 178). Oradea became a gathering point after the war for returning Hungarian and Rumanian Jews. In 1947, 8000 Jews lived in Oradea, and in 1976 there were 820 (Encyclopedia 1995, p. 1068).

### Founding new families after the liberation<sup>21</sup>

A new period began for the three sisters now, a period of waiting and hoping for other members of the family to return, but most of those, who had survived the Shoah, were younger relatives or friends.

---

20 Viola was interviewed in Hebrew by Yael Moore in 1995.

21 Between 1993 and 1996, we interviewed all the members of the second generation, Irina's two granddaughters, and Sarah's oldest granddaughter.

Soon after their return to Oradea, Sarah and Tamara married men they already knew before they were sent to the concentration camp. Irina married a man from Transylvania in 1947. All three husbands had been in forced-labour camps during the war.

1947 saw the birth of Irina's daughter Miriam and Sarah's son Karl-David, who was named after his murdered grandfather. Sarah did not feel strong enough to have another child. And it was Irina's husband who did not want to have any more children after Miriam. Tamara had two children: David, who was born in 1951, and Viola, born in 1954. Both were named after murdered grandparents. Tamara very much wanted to have children, even though doctors had warned her that a pregnancy might kill her. Between the liberation and her emigration to Israel in 1964, Tamara was almost permanently very ill and spent long periods in hospital because of her lung disease. After the birth of her daughter, Tamara felt so overwhelmed because of her illness, that her son went to live with his father's parents when he was two. He stayed with them until he was six. So David spent a large part of his childhood away from his parents, just as his mother had been apart from hers. He too still struggles with the feeling of having been abandoned. His sister Viola also felt neglected by her parents. She said they were always working: "*We didn't have any parents.*"

The three families applied repeatedly to the government over a number of years for permission to leave Rumania. Sarah and Tamara finally left for Israel with their families in 1964. Irina and her family emigrated the year after to West Germany. After a few years, Sarah and her husband also decided to move to Germany, since the Israeli climate did not agree with her. Their son Karl-David was in the army at the time and wanted to stay in Israel. At the request of his mother, however, he agreed to come to Germany for five years, where he completed high school and attended university. The relationship between mother and son is close. For Sarah, Karl-David is "*the most important person in my life.*" While serving in the Israeli army, Karl-David met the woman who was soon to become his wife. They married young, she came with him to Germany for the five years that he had promised his mother he would spend there. Their daughter Naomi was born in Germany in 1971. When his father suffered a heart attack and was forced to work less, Karl-David broke off his studies to help run the family restaurant. But when the five years were over, he and his family returned to Israel. His parents remained in Germany until they retired. Now they spend the winter in Israel and a few months in the summer in Germany. Back in Israel, Karl-David and his wife had another daughter and a son.

At Sarah's urging, Tamara and her family also moved to Germany in 1973. Tamara and her husband, their son David, their daughter Viola, and Viola's husband all worked in Sarah's restaurant. After two years, they returned to Israel. David has two daughters, Viola has two daughters and a son.

*Living in the land of the perpetrators: Irina and the family of her daughter Miriam Svoboda*

Irina: "The seduction"

Let us consider Irina's experiences and her family biography.<sup>22</sup> The separation from her family in Auschwitz marked for Irina the break between the past and the present. What this means for Irina became clear in the very first minutes of the interview.

It began with a dialogue about the interviewers' research. Irina said she could understand the Germans' enthusiasm for the Nazis. She drew parallels between Nazi sympathizers and herself, arguing that the masses can be seduced: "*I have experienced it myself how the mass can be seduced, and I was terribly upset at myself (2).*" The story she then proceeded to tell explains why she accuses herself of being susceptible to seduction.

Irina began talking about her arrival in Auschwitz-Birkenau in the summer of 1944 with a lengthy narration of the "selection procedure" at the ramp. What she related was a "seduction" by Mengele, the Nazi physician who decided who would live (temporarily) and who will die:

*"I had an experience with Mengele. I didn't know that it was Mengele, so I hadn't noticed when-, because we had to line up in rows five abreast. And we were four girls and my mother I was the oldest on the one side and my mother on the other side. There was a dashing officer standing there with his little whip in his hand (1) and he even spoke to me. Although it was so hot and we weren't allowed to take anything with us, but we took only our best things with us from the ghetto because, we weren't allowed to take everything. And I still had a flannel costume on, and on top of the flannel costume a trench coat. And in the ghetto one wasn't allowed to, one wasn't allowed to have long hair. My father was very proud of his daughters, and I was the only one who was dark, all my three, other sisters were blond. We made plaits and we put the plaits up, and I had a red silk scarf and they were, somehow, tied up in it, and despite the five days, in cattle cars we still had, at twenty you look young. Youth makes you beautiful. Really you can be as ugly as anything, (as long as) you are young. And this officer spoke to me, he said: 'Why are you looking at me so angrily?', and I said: 'I have no reason to be feel pleased', and with that I was past- yes, and he said: 'You could be a little friendlier' (1) and with that we were past him. And then I look round quickly and my, my mother and my little sister aren't there, she was twelve years old, she looked like my Ingrid, like my young, youngest granddaughter*

---

22 For a detailed case study, cf. Jordans 1996.



*in the face, she has different features but similar, but so blond, such long yellow plaits. There were helpers there at the ramp in these striped outfits we thought we're in a mad house we didn't know, we came from civilization, and he said: 'For goodness' sake why weren't you a bit more friendly you don't know who that was', I say: 'And I'm not interested either' and he says: 'But that was Mengele' (1) but the name didn't mean anything to me. (1) So, that was my Mengele experience, afterwards it, I can- , I wouldn't be able to recognize him today I can only remember there was a good-looking (1) officer such a dashing (1) man, and, (1) the next day we were registered by name (2)"*

Let us try to reconstruct what happened in that situation at that moment. During the incredibly fast "selection procedure" on the ramp at Auschwitz-Birkenau, Mengele addressed Irina. She reacted boldly, unaware that her life was at stake. But it all happened so quickly that she did not notice that her mother and youngest sister were separated from herself and the two other sisters. She could only have realized afterwards what the separation meant – that her mother and the twelve year old Hannah were most probably killed immediately in the gas chamber. If we detach Irina's story from the context of Auschwitz for a moment, we could view it as follows: a young and dashing officer addresses a young and well-dressed woman, who is still looking fresh despite a long and arduous journey. The young woman responds with a pert remark. How should we interpret the differences between the experienced situation and Irina's presentation of it? First, Irina's narration not only makes clear, that her appearance was very important to her but also that she survived because of her looks. Perhaps concentrating on her appearance helped Irina feel she had some control over her fate, that she could deploy her looks to improve her chances of survival. The narration focuses on the fact that Irina did not appreciate Mengele's importance, which is an indirect indication of Irina's feelings of guilt. She reproaches herself for not perceiving how dangerous the situation was. Afterwards, Irina could not face the thought that her mother had been killed. She spoke differently, however, about her father. Asked again about what happened at the "selection procedure", she said her father went voluntarily with her younger brother to the left. She was sure her father had died then, but in Stutthof she was always looking for signs that her mother was still alive. She would often reassure her sisters that their mother had come on another transport.

*"The experience with Mengele", as Irina refers to the "selection procedure" in Auschwitz, was so painful that she cannot visualize her mother in the situation following their separation. Asked if she had a mental image of her mother at the "selection procedure", she answered: "Don't have one, don't have one (1) it is such a terrible thing that I don't have any because, as I said he spoke to me (2) I answered and we moved on."* Irina explained what the separation meant for her:

*"I always have the feeling they amputated me (1) as if something had been cut off (1) like an amputation. Suddenly (1) there were just three of us (3) It was as if, as if one had had a hand chopped off, so that I don't have any any memory. I don't know how she, how she went le-, eh, left. I don't know what kind of a face she made. I have absolutely no-, it is such a terribly painful thing that he, distracted me (3) that I, I I don't know, it isn't, it isn't there."*

Irina has never allowed herself to picture her mother's death. Someone she knew, who worked in the crematorium, told her exactly "how it happens", but she could never imagine her mother in that situation: *"I know how the people were killed, but I never connect that to my mother. That is probably too, too painful for me that I (2) that you bring it up now, now I realize that I have never imagined it, in my mind's eye, because probably it is too painful to be able to picture that at all."* Irina goes on to say that after the liberation it took her a long time to accept the fact that her mother had been murdered.

Back in Oradea, Irina, then twenty-one, got to know her future husband Miron Kovacs, who had survived the war in a forced-labour camp. Miron's first wife and three-year-old son had been killed in Auschwitz. Miron was twenty-two years older than Irina and had a doctorate in law. He came from a prosperous family and had converted to Catholicism in the thirties in order to elude the anti-Jewish measures. Irina was happy to cede to her husband some of the parental role she had adopted toward her sisters: *"At last I could give up being grown-up and could be a child. My sisters were provided for and I just fell in love with this man."*

Irina and Miron's daughter Miriam was born in 1947. They lived in Communist Rumania until, after applying many times for permission to emigrate, they were allowed to leave for Germany in 1965. Miron could not qualify to practise as a lawyer in Germany and worked as an assistant in a law practice. He died in 1981 at the age of 79.

Miriam: "I have always been a stand-in for someone else"

Miriam<sup>23</sup>, who was born in 1947, has a doctorate in musicology and lives with her non-Jewish husband Achim Svoboda and their three daughters in Germany. Miriam concentrated on her roles as mother and homemaker until a few years ago. Now she is again undertaking small research projects.

The way Miriam feels about her life has been determined by the delegation imposed by her family history. It is an assignment that she has accepted: to live as a proxy for others, for those who were killed. She exemplifies what Dina Wardi has described as members of the second generation adopting the role of "memorial candle": "Not only must they fill an enormous emotional void, but they must also construct the continuation of the entire family history

---

23 Miriam was interviewed twice by Gabriele Rosenthal in 1993.

all by themselves, and thus create a hidden connection with the objects that perished in the Holocaust (Wardi 1992, p. 27)."

Miriam's entire biographical self-presentation is marked by her difficulty in separating her own life from her family history. She depicts a life in the shadows cast by her murdered relatives. Her own projects, as a musicologist and mother of three teenage daughters, find scant mention in Miriam's life story.

### Miriam's life in the shadow of the Shoah

When Miriam was asked to recount her family history and her own life story, she made clear from the start that she cannot separate the two: "*It is not easy for me to separate them from each other because I never knew any of my grandparents.*" The interweaving of her own life and the family history was evident throughout the interview. Having stated that her grandparents are part of her life story, because she only knows them through stories her parents told her, she concluded that that is the reason why she "*inevitably swings back and forth*". After presenting an outline of the family history and the childhood and youth of her mother, Miriam ended with a brief account of her father's professional career. So far, she had not said anything about her parents' experiences in the war or their persecution. Instead she asked the interviewer to ask her some more questions since "*nothing more comes to mind at the moment.*" Breaking off in this way can probably be interpreted as a manifestation of how hard she finds it to see her parents' life before the war, their suffering during the war, and her own life as connected, as a continuum. When the interviewer asked Miriam to recount her life story, she answered that it too "*indirectly had to do with the prehistory*". She first talked about how her parents met after the war and mentioned that her father lost his first wife and three-year-old son in Auschwitz. She said her father could never really get over the loss of his first family and never overcame his grief at the death of his son "*whom he probably loved with all his heart*". Miriam ended the sequence about the "*prehistory*" by saying her father had driven his first wife and son to the ghetto himself before he went off to a forced-labour camp. Although his wife had a visa for the United States, she wanted to remain with her family in the ghetto.

Miriam's own life is overshadowed by this prehistory, the central element of which is the killing of her father's first family. The family biographical constellation is such that Miriam was only born because her father's first family was killed. This becomes clear in the textual structure of Miriam's account of her own life. Miriam began her biography with a "*family anecdote*", which she had heard from both her father and her mother and which is still part of the repertoire of stories told within the family dialogue: When she had just been born and her father looked at her for the first time, he cried out: "*A girl*

*and ugly to boot!"* This story, the first she told us about her own life, reveals more than just her father's wish for a son. It was often told within the family, continually reminding Miriam that she could never replace the son her father had lost. Miriam was thus condemned to fail, like many other children born after the war to parents who had lost a child in the Shoah (Kestenberg 1982, p. 95).

Miriam presented a lot of evidence to suggest that her childhood and youth had been quite normal. She argued that there were many children in Rumania who had had it much worse than she had; that the grown-ups' stories about the concentration camps had not upset her; for her it was a part of everyday life to see the grown-ups sitting together *"talking about the camp"*: *"I can remember often falling asleep as a child on the couch or sitting in the armchair and I always heard them, again and again, the same stories and about my mother's parents, the phrase was always 'stayed in camp'"*.

She also said that her Jewish background was not a problem for her, since the family did not celebrate religious festivals or observe Jewish customs. This account of an untroubled childhood was interrupted - despite Miriam's best efforts - when the issue of her "own suffering because of the past" surfaced. But since she does not believe she has the right to suffer - in light of or in the shadow of the children who were killed -, she cannot give voice to her own suffering because of the past by talking of what she herself has gone through. Instead she talked about suffering in her dreams. In dreams that have recurred since her childhood, she is with her parents and they are being pursued; they try to run away. The predominant feeling is anxiety. Miriam distinguished this anxiety from other kinds of anxiety; she called it a "we-anxiety" and not her own personal fear. Miriam feels so wrapped up in her parents' years of persecution that they have become the setting of her own dreams. Miriam has become part of that time and herself feels her family's fears.

After talking about these dreams Miriam immediately made light of her pain and said being Jewish had not been a problem for her as a child:

*"Of course there were many children who had it much worse than I did, I never suffered because of that, never, suffered I can't remember that. And that I heard the stories from the camps, again and again, that didn't make me suffer either. For me it was normal, I ((amusedly)) grew up with it (2). The only bad thing was when I dreamed, about these things, and the dreams were, I can remember quite vividly they were very, real and I was always in the midst of it all I didn't dream my parents were being pursued or in jeopardy, instead, I was always in the midst of what was happening, right in it (3) eh (2) being Jewish or not was as a child not a problem (4)".*

She did not allow herself to have problems or to be a cause of worry for her parents, even as a child. She said as much during a joint interview with Miriam and her mother conducted by Gabriele Rosenthal and Bettina Völter

in 1995: *"I always really had the feeling that it was my highest duty not to anger my parents to do everything just the way they wanted me to, just to be a joy for them."* Traces of the frustration this role involved and of suppressed aggression toward her mother could be discerned during the interview. The mother and daughter gave voice to their own pain, but they hardly addressed each other. At the same time, they declared that they have a *"really good relationship"*. Irina talked about having been humiliated and dehumanized. Miriam said she feels she has had to adopt the role of her parents' protector. The interviewers tried to encourage the mother and the daughter to address each other directly. When asked how she felt when she hears her daughter say she feels she has to protect her, Irina answered firmly, almost aggressively: *"I do not need protecting"*. She brushed aside the interviewer's request that she say that to her daughter directly: *"I never said she should protect me"*. Irina interpreted her daughter's behaviour as a result of her husband's traumatization. Then she cried and said she had desperately wanted another child but her husband pleaded with her: *"I don't want any more children, I can't bear the feeling of losing a child any longer"*. She said her husband oppressed their daughter *"with his excessive love, assailed her with his love, overwhelmed her; this love was egoistic and she felt that, because he was so frightened, it wasn't normal, he couldn't bear the feeling he might lose another child."*

When asked by the interviewers to talk about what they wished for in their relationship, the mother and daughter made clear that they wanted closer contact to each other. At the same time, they remained distant from one another. Miriam said she wished she could talk to her mother sometimes about her own problems and worries instead of keeping quiet about them out of consideration. Irina for her part said she was hurt sometimes by her daughter's reticence. There were indications in the dialogue, that the problems Miriam refrains from talking about have to do with her husband, and that Miriam is caught in a conflict between loyalty to him and loyalty to her mother. Miriam would like her mother to visit her more often. But Irina wants to lead her own life. Then Irina mentioned that she lost her mother when she was twenty. Both said they can each feel the other's affection and do not need any outward signs of affection such as embraces. Miriam stated: *"In our family in general it's not done to hug each other all the time or give each other a kiss, to hug when we say goodbye"*. Her mother added: *"I don't need the proof, anyone to touch me"*.

### Miriam's internalized objects

Talking about her cousin Ibi, who was killed in the Shoah, Miriam said, *"I have always been a stand-in for someone else"*. Ibi was the daughter of her father's sister. She was taken away on a transport when she was eighteen and *"stayed in the camp"*. As a young child, Miriam was called Ibi. It was only at

school that she learned that the name on her birth certificate was Miriam. Looking back, she said it was a burdensome role that had been imposed on her: *"I was always the (1) stand-in for someone else and I think it was like that for many after the war, that in some way they had to make good for the children 'who stayed in camp'".* Miriam speaks of "making good" to express that she feels she was forced to endure something very unpleasant. For which elements of the family history does she feel she has to 'make good'? Does she also feel aggression from her parents? Miriam continued:

*"Had to, that sounds harsh perhaps. It wasn't meant like that at all on the part of the older generation but I do think that the other children like me certainly felt it. And probably learned in this way either, eh, positively or negatively or either in terms of an identification with this, delegation, or in opposition to it."*

Many passages in the interview confirm just how much Miriam identifies with this delegation and accepted the assignment to live on behalf of, to stand-in for, the dead - and not only for her dead cousin Ibi. Even more crucially, she has had to stand in for her father's murdered son and for her mother's murdered mother. Miriam feels that her grandmother is a part of her: *"The mother of my mother eh (4) lives in me as eh as a- (2)".* Miriam hunted for the right term: as what does she live in her? Miriam was trying to express that she has internalized her mother's mother as an object, but that it has remained indeterminate. She continued: *"as a set of attributes (2) that I somehow tried to emulate, probably to make my mother happy".*

We can interpret that statement as follows: Miriam internalized the mother of her mother as an unknown object and accepted the delegation to keep this object alive by trying to emulate the set of her attributes.<sup>24</sup> But Miriam cannot fulfil her mother's expectations by adopting her grandmother's qualities. How could a daughter succeed in replacing her mother's mother? For Irina, delegating her daughter to replace her mother was probably also linked to Irina's wish to resolve conflicts with her (cf. Wardi 1992, p. 32). Miriam, like any other member of the second or third generation, has no choice but to fail in such an assignment.<sup>25</sup> After the statement quoted above, Miriam added that her mother rebukes her regularly for working too much and for not letting her daughters help her. Miriam said she resembles her grandmother in this respect: *"Now I realize that I still try to verify in my family a lot of what my mother told me, respectfully and with love, about her mother."* What is it she wants to "verify" in her mother's reports? Does

---

24 Cf. Kestenber (1989) and Danieli (1993) on the internalization of murdered relatives in the second generation.

25 The dynamic between a daughter and a survivor mother, who has lost her own mother, is defined to a significant extent by the mother's feelings of guilt towards her mother and her anger at having been abandoned by her (cf. Wardi 1992, p. 40ff.).

Miriam have doubts about what her mother told her, and does she try to counter these doubts by living in a certain way with her own family, with her husband and their daughters?

Miriam's stories about her mother's separation from her mother in Auschwitz also reveal, that Miriam cannot accept that her grandmother really died in the gas chamber:

*"The younger brother and the youngest child a girl were driven, to the side, at once by Mengele (2), the ones who were to go to the gas chamber. My mother never saw her mother again after that. But how specifically the grandparents, were killed, I don't know and as far as I know my parents don't know that, didn't know that either."*

Miriam talked as if her grandmother had not been sent to the gas chamber like the two youngest children. When asked about her mother's youngest sister, she said: *"She ((Miriam's mother)) always talked about how, the little one, how Hannahle stood there and held tight to her mother (3) Since then, they never saw each other again (6) but as I said, exactly when and how they were killed (3) that I don't know."*

Miriam has a vivid fantasy image of the "selection procedure": *"as if from a cinematic perspective, from up on high, with my mother and her family around her"*. She talked of a blurred image, could vaguely make out the faces of her grandfather and Hanna, with her blond plaits, and her mother's brother, but she cannot see her grandmother at all.

### Miriam's Life Story: Being Jewish and living in the land of the perpetrators

Miriam grew up in Rumania in a Hungarian-speaking environment. She spoke only Hungarian, at home and in kindergarten, until she started school. Most of the main figures in her life were relatives of her mother. The only other child, with whom she had much contact, was her cousin Karl-David, Sarah's son, who was the same age as her. Miriam was first confronted with the world outside the family when she started school at the age of six. She had to learn Rumanian. It was a challenging constellation, but one that also offered Miriam the opportunity of socialization outside the family. Miriam became a member of the pioneers (a socialist youth organization) and was successful at school, almost always among the best in the class. When she was fourteen, she went to a high school specializing in music and the arts. Miriam had not quite finished school, when in 1965 the family finally received permission to leave the country. Her two aunts and their families had left for Israel the year before. Looking back, Miriam says she understands cognitively why her parents wanted to emigrate, but that emotionally it was very hard for her to leave. They moved to Germany, and Miriam went to a special boarding school to learn the language. She only spent the weekends with her parents. Miriam was

eighteen when she left home, the age at which her cousin Ibi was "deported" and never came back.

Emigration marked a radical biographical turning point in Miriam's life – she lost her language, country and much of her family. She was separated from her aunts and their families, including her cousin Karl-David, who was like a brother to her. Miriam has never been to Israel to visit her relatives. When the interviewer asked her about this, Miriam said she had never even thought of telling her husband about her long-standing wish to visit Israel. From the family in Israel we know that they are very disappointed at what they see as ignorance about Israel and being Jewish. Karl-David said this was further proof that Jews should not live in Germany. This turning point in Miriam's life – moving to Germany when she was eighteen – involved above all switching to a non-Jewish German environment. She met her future husband Achim at the school where she learned German. They were both on a special course for young ethnic German immigrants from Eastern Europe to complete the German high school diploma. They then both went to university and lived together for several years. Miriam completed her doctorate but withdrew from professional life when their first daughter was born in 1975. She said she also stopped making music at that time. In her late thirties, when her third daughter started kindergarten, she began to work again, to undertake research projects, and to play music.

Since she was eighteen, Miriam has lived with a man whose parents were active in Nazi organizations until 1945. Achim Svoboda<sup>26</sup> calls himself a Sudeten German. He was born in 1944, before the end of the war, and spent his childhood and youth in Czechoslovakia. He emigrated to Germany with his mother in 1965. His father died of a heart attack in 1958, a year after he was released from prison, suffering from tuberculosis, after having served ten years. The court file<sup>27</sup> on his trial in 1947 says he was convicted of "supporting and propagating the National Socialist movement". He was charged with membership in diverse "fascist organizations". He had been the director of a clinic. A further charge was denouncing a Czech resistance fighter, who was then taken away by the Gestapo. Achim's mother, since deceased, was also active in the Nazi women's organization.

Achim's childhood was overshadowed by the imprisonment of his father or rather by his absence, which was not explained to Achim for a long time. Achim said a neighbour told him that his father was in prison, when Achim was five and his father had been gone for two or three years. Until then, his mother had always said his father was "*on holiday*". Achim can only remember visiting his father in prison two or three times. His relationship to his father was based almost entirely on projections and hardly at all on time they

---

26 Bettina Völker interviewed Achim Svoboda twice in 1993.

27 This information comes from archival sources.



had spent together.<sup>28</sup> He formed a very close bond to his mother. Achim's feelings about his father are still ambivalent even today – as the following story indicates: shortly after Achim started school, he found a suitcase in the attic at home. In it was a Nazi badge (perhaps the party emblem) and his father's Nazi party membership book. Achim was shocked by this discovery and felt "*pain and anger*". Achim says today: "*It wasn't the finest of things but I could relativize it.*" At school, he had been told that all Germans were Nazis and criminals. And now, suddenly, his father belonged to that category. The issue was not mentioned within the family. Achim's mother had no sympathy for his moral doubts. He said in the interview, that his mother had also been "*duped by Nazi propaganda*". At the time, Achim needed to "*relativize it*". For Achim, these "relativizations" are still valid today: he says his father could only pursue his career as a civil servant as a member of the Nazi party. He claims he was not guilty of any serious crimes. After his father died, Achim found the arraignment document. He still has it. He said his father was condemned for being a member of the NSDAP and for handing over "*radio-active material to the German Wehrmacht*". He did not mention the charge of denunciation. He did, however, talk about persecuted individuals, whom friends told him his father allowed to hide in his hospital.

Achim said the first years at university in West Germany were the worst time of his life. He was confronted with the '68 student movement. He was called a "*fascist*" and a "*reactionary*" by other students who "*raved about Communism with gleaming eyes*" and were busy accusing their fathers of having been Nazis. He was frightened Communism could "*break out*" in Germany. "*I had the impression we should have our packed suitcases ready in the corner*", he said, invoking a metaphor that is commonly used by Jewish families in Germany. Below, we shall show that he draws many parallels between his own biography and the Nazi persecution of the Jews.

What does Miriam's marriage mean to her?

In the course of her biographical self-presentation in the interview, Miriam talked about her husband within the thematic field of "*my being Jewish*". The story about her husband is one of three stories she told during the main narration. The rest was made up of arguments, reports or descriptions concerning her family history and life history. The three stories all have to do with being Jewish.

The first story she told is about a girl she knew who was given a bad grade because she did not come to school on Yom Kippur. The injustice of it troubled Miriam a lot. She complained to the school director who then

---

28 The central importance in his biography of a childhood without a father is something Achim shares with many of his generation whose fathers were prisoners of war (cf. Michael Liebig in Chapter 4.3).

awarded the girl the grade she deserved. Miriam said: *"That was the first time that I felt Jewish."* This story was one of the few passages in the interview in which Miriam presented herself as an autonomous agent. She acted to counter an anti-Semitic act in the non-Jewish world around her that had to do with Yom Kippur, a day on which Jews remember their dead. Although she at first stated firmly that she had not been brought up religious and that in line with Socialist ideology she had seen Judaism merely as a religion, she recounted this situation in which she defended another Jewish girl, whose problem had to do with a Jewish holy day and in which she, Miriam, felt Jewish for the first time.

The second story was about how she met her future husband. Early in their relationship, Miriam told Achim, after they had been to the cinema one evening, that she was Jewish:

*"I felt the need to tell him that I am Jewish, he said he knew that (2) probably because I had never made a secret of it and (3) told stories about my parents and so on, and with that the issue was closed. It was never an issue again (6)."*

Like the first story, the second is also about being Jewish. With the sentence, *"The issue was closed"*, Miriam made very clear what being Jewish and her marriage to a non-Jew mean to her. Miriam said explicitly that her background was not an issue in her dialogue with Achim. Since the start of their relationship *"the issue was closed"*. In line with that, they did not address the theme of their very different family pasts. The couple concentrated more on something that had affected them both - suffering under a socialist regime:

*"Interestingly it was more the case that our experiences under Communism (2) were more important. That occupied us more than membership in some people or religion. It was more central for us to (1) we had many more conversations about, eh, various incidents, with eh, the harassment, there were under Communist rule, that was also probably a common denominator."*

The third story Miriam told us was also about being a Jew. An old man on his death bed calls for the rabbi, because he wants to be recognized as a Jew and be buried in the Jewish cemetery. The rabbi comes and he asks the old man, why he had never made himself known to the Jewish community before. The old man answered: *"I never wanted to be on a list again"*. Miriam ends the story by saying, *"And I think my reasons are similar"*.

All three stories are about Miriam's being Jewish. In the first story, she revealed that she was Jewish; in the second, being Jewish was no longer an issue when she met her future husband; and in the third, she explains why she does not want to belong to the Jewish Community. By marrying a non-Jewish German, Miriam entered a family with an entirely different background. It is

striking in her biographical self-presentation that after the story about how she told her husband about her Jewish ancestry, she jumped over all the years of her marriage and started to talk about the present. She ended her main narration by talking at length about how she and her husband have a very small circle of friends. She ended her life story in 1965 and did not talk about either her career or her children. The interviewer asked repeatedly about her life after 1965 and her career, but Miriam still did not tell any stories. When asked about her years at university, she said she had *"spent all those years in a kind of chrysalis state."* She said again that she had few contacts outside her marriage and ended as follows: *"That is probably why I don't have any memories, or no real memories of my school years or student years, because I really only started to live my life much later, to be precise in my mid-thirties."*

### The supportive marriage system

In order to understand the significance of her marriage to Achim, let us see how he deals with their very different family histories. Achim is one of those who through a strategy of pseudo-identification with the victims appear to adopt their perspective and thereby avoid dealing with the perpetrators. He presents his family history and his own life as the story of victims of Stalinism. He draws parallels between the Nazi persecution of the Jews and the persecution of ethnic Germans in Czechoslovakia after 1945. When the interviewer asked how it felt to have married a woman, both of whose parents had been in a concentration camp, he answered: *"Of course I can understand it quite well, because in a certain sense I also experienced it myself and I can put myself in their shoes quite well."*

He said his mother-in-law talked about it a lot and that a *"certain wave of satiation had been reached and one has the feeling it's time to roll down the shutters"*. His answer to the question of what he knew about the past of his parents-in-law reveals even more clearly, that he refuses to appreciate their perspective and draws parallels between his own family history and that of his wife. He mentioned the restrictions on travel that had been in force in the socialist states: *"I grew up in a situation like that, in an enormous concentration camp and you weren't allowed to get out. Basically we only heard about other regions and countries in school."*

By equating the two situations, Achim can avoid addressing issues about his own family's past and possible accusations of being implicated in the Nazi system. The background to this is his own experience of persecution as a German in a European socialist country after 1945.

We have seen in other families already that focusing on cruel treatment under a Communist regime in Eastern Europe after 1945 has been used as a means to avoid facing possible guilt for crimes before 1945. It is a typical strategy adopted in the former socialist countries for dealing with the Nazi past.<sup>29</sup>

As art of his repair strategy, Achim attempts to displace guilt on to Miriam's family. That became clear in an interview that Gabriele Rosenthal and Bettina Völter conducted with Achim and Miriam in 1994, when he openly attacked his wife and her parents. He accused his mother-in-law of being too demanding during her visits and talking too much about having been persecuted. He was also outraged that in the family Miriam was called Ibi, which was the name of Miriam's cousin who was killed. He was most aggressive in attacking his late father-in-law. Asked if there were any unanswered questions in the past of his wife's family, he said: *"Yes, there is one point I would have liked to ask your father about. There were times when he so-to-speak left his family in the lurch - his first wife and his son. It was a murky story why they were separated and the wife and child disappeared in the concentration camp and he remained alive."*

One might have expected Miriam to react with anger to such an implicit accusation. But when her husband left the room to answer the telephone, she told the interviewer that Achim projected the anger he felt toward his own father onto her father. When Achim came back, Miriam told the story: her father was in a forced-labour camp and his wife wanted to be taken to the ghetto to be with her family. She relativized this account by adding, *"At least that is what I was told" and "that's the way I know the story"*. Her husband pressed home his accusation: *"I never understood that, it contradicts any rational logic"*. Miriam corrected him: *"any retrospective rational logic"*. Then Achim turned his aggression against Miriam: *"That reminds me of the misunderstanding we had today"*. This *"misunderstanding"* had been thematized in the first half of the interview. Achim had accused his wife of coming late to an appointment. Whenever Achim attacked Miriam during the interview, she more or less accepted his charges. This time she said: *"Could be. But it could also be that I am now trying to defend my father."* But in a firm voice she carried on: *"But I don't think one could judge from his perspective at the time what a ghetto really was and what it wasn't."*

To view this exchange simply as an attack by Achim on his wife and her parents would be to overlook the function Achim's accusations have for Miriam. We propose that Achim asks the questions that Miriam does not dare to ask herself. Achim is the one who expresses the aggression towards her parents

---

29 In the case study of a Russian family, the grandmother's collaboration with the Nazis was clearly offset and excused by her subsequent banishment after 1945. The second and third generation talked about the grandmother's life without mentioning her active role in both the Nazi system and the Soviet system. They presented her only as a victim. A similar tendency was observed in the Seewald family (Chapter 5.3).

that Miriam has to suppress. This is a mechanism that we have observed in the system of other second-generation marriages between a Jew and a non-Jewish German – marriages in which a Jew from a survivor family seeks a partner with a different family history who can express aggressions in his or her stead. John Byng-Hall (1973, p. 241) has described such a distribution of roles: *"Each spouse finds his or her split-off aspects in the other, thus both sides of the split, e.g. aggressive/submissive, are represented in outward and visible form and in a more hidden form in the reverse order."*

Her marriage to a non-Jewish German presumably also helps Miriam to feel secure in the land of the perpetrators and to ease the burden of the persecution in her parents' past. We assume that Miriam and Achim both find support in the marriage system and that it serves in their avoidance of awareness of certain parts of the family history.

### The granddaughters: The neutralized family history

Miriam and Achim Svoboda have three daughters, Susanne, born in 1975, Klara, born two years later, and Ingrid, who was born in 1981. The two older daughters were interviewed by Bettina Völter in 1993. The younger of the two did not want to be interviewed alone, so they were interviewed together. The youngest daughter did not want to be interviewed at all.

Susanne and Klara could not say much about their family history before 1945. They know some stories about their mother's parents, but they know nothing about the history of their father's family during the Nazi period. Instead, they concentrate on the family's past after 1945 and emphasize, much like their parents, the common experiences of both sides of the family under socialism. They said repeatedly that their parents and grandparents in Rumania and Czechoslovakia were not *"loyal to the system"* and therefore did not *"please the regime"*. Susanne and Klara made almost identical statements using almost the same words on this topic. For them, the differences are "blurred" between National Socialism and the Communist state, *"in which the system was similar to the way it had been under Hitler"*. From this perspective, the fundamental differences between the past of their mother's family and that of their father's family before 1945 is also "blurred".<sup>30</sup>

Susanne and Klara both said that their father's father, who died in 1958, had been a prisoner of war for many years and that he had been in a Czech prison for a while because *"society did not like him"*. Klara said he had also been against the Nazi system. Despite his Nazi past, both granddaughters presented him as a victim of World War II and the Communist regime. Klara pictures him as very authoritarian because he was *"very hurt by the war not*

---

30 The grandchildren of the Baslers (Chapter 4.2) also blur the differences between their Jewish and non-Jewish family histories.

*only physically but also mentally*". Susanne has a very clear image of how he died: she visualizes how he feels feint, collapses and dies on the street, not long after his release from prison. This fantasy resembles the images they have of the deaths of their Jewish relatives in the Shoah. Susanne said one always hears about the gassings, but the death of their family was "*much more concrete*". The idea of people being killed in the gas chambers is so threatening, it cannot be imagined. The idea of dying of illness is more bearable:

Susanne: *"They often died because of all the strain they were subjected to, they were often killed by disease, they were just skin and bones and in that sense they weren't really killed, they just-"*

Klara: *"The torments they had to work so hard and didn't have enough to eat, they just dropped on the death marches."*

While the two sisters have a virtually identical perspective of their father's family history, a division of roles could be discerned in their accounts of their mother's family history. Susanne avoided talking about the persecution of her grandparents Irina and Miron, Klara brought it up persistently. Susanne started her account of her mother's family history by talking about the professional situation of her grandparents in Communist Rumania. Klara added that her grandmother had lots of younger siblings and therefore had to help in the house as a child. She carried on: "*So later, in the concentration camp, she had to look after the younger ones*". Two of the children were "*taken somewhere else*" with their parents and "*were killed*". The ensuing dialogue between the sisters made very clear, how Klara moves from post-war history to the period of persecution:

Susanne: "Then in forty-seven my mother was born and she was the only child in the family and uuhh"

Klara: "Although our grandfather, he already had a wife before and he had a child with her, but, they were also both killed in camp (1) and it was after that that he got to know our grandmother (5)."

Susanne: "Now I only know from my mother that she grew up under pretty strict conditions. My grandpa he was pretty disappointed that she was a girl and not a boy. At the beginning he couldn't build up a relationship with her, because he always lived with that disappointment that he didn't have a son."

Klara: "especially because he lost his first son."

Susanne and Klara both said they learned most of what they know about the persecution of the Jews at school and from books. Susanne said how "*surprised and shocked*" she was when she heard in passing that her grandmother

had also been in a concentration camp. Klara can remember that her grandmother once told her about her persecution *"after the separation from her parents"*. We could sense more and more strongly Klara's sadness as she continued to talk about her grandmother Irina. Her older sister blocks out the feeling. She argued, just as her father did, that the family also had it tough in Rumania and Czechoslovakia after the war. It is too threatening for Susanne to distinguish between the two family histories. She does not want to *"think about her Jewish ancestry because I think in principle it doesn't really matter what their ancestry is because a person is a person."*

Klara, on the other hand, is not so sure. She brought up the matter in the interview and, talking about her mother's *"Jewish ancestry"*, said: *"that we are also somehow descended from there, that it has to do with us too"*. The interviewer asked, *"Would you also say that you had Jewish ancestors?"* and Klara replied, *"No, not really. I am not really aware of that."*





## 6. The collective trauma of the Lodz Ghetto: the Goldstern family

Gabriele Rosenthal, Michal Dasberg and Yael Moore

### *A family past of persecution*

In the Goldstern family, the grandfather and grandmother survived the Lodz Ghetto, forced labour camps and the death camp of Auschwitz-Birkenau. As the genogram indicates, Amos Goldstern was the fifth child born into a German-speaking Jewish family in 1917 in Lodz. Before Amos was born, his parents had lost a daughter at the age of six months. They went on to have five more children, one of whom also died when he was six months old.

When the ghetto in Lodz was established in 1940, Amos lived with his mother and his four younger brothers and sisters. His youngest sister Nava was fifteen years old at the time. Their father had died in 1938, and Amos' three elder siblings already had families of their own. Thus, Amos was the oldest son still living at home and assumed the father role in the family in certain ways.

In 1940, Amos left the ghetto and his family, having "volunteered" to go to work in Germany, to be better able to provide for his family from there. He had found it very hard to see his mother, who hardly ate bread herself any more, go hungry and sacrifice herself for her children. He talks about this again and again in the individual interview and then in the family interview, as well<sup>31</sup>:

*"So I was the oldest at home and I took off for everybody a piece of bread ... and I found out that my mother gave her ration of bread to the youngest sister. I couldn't take this. The Germans were looking for workers, strong young people. I said to myself in this way perhaps I will help them".*

For Amos, this was the beginning of a journey lasting four years through many different camps. From 1943 to January 1945, he was an inmate in Auschwitz and worked in the Buna factories of the I.G. Farben Company. Under the most extreme conditions, he survived an evacuation to Buchenwald as well as transports to other camps just before the liberation. In April 1945, he managed to run away from a "death march" with a friend.

---

31 This is the original English. The family interview was conducted in English, although some participants occasionally spoke German, Hebrew and Polish, as well (cf. 6.1).

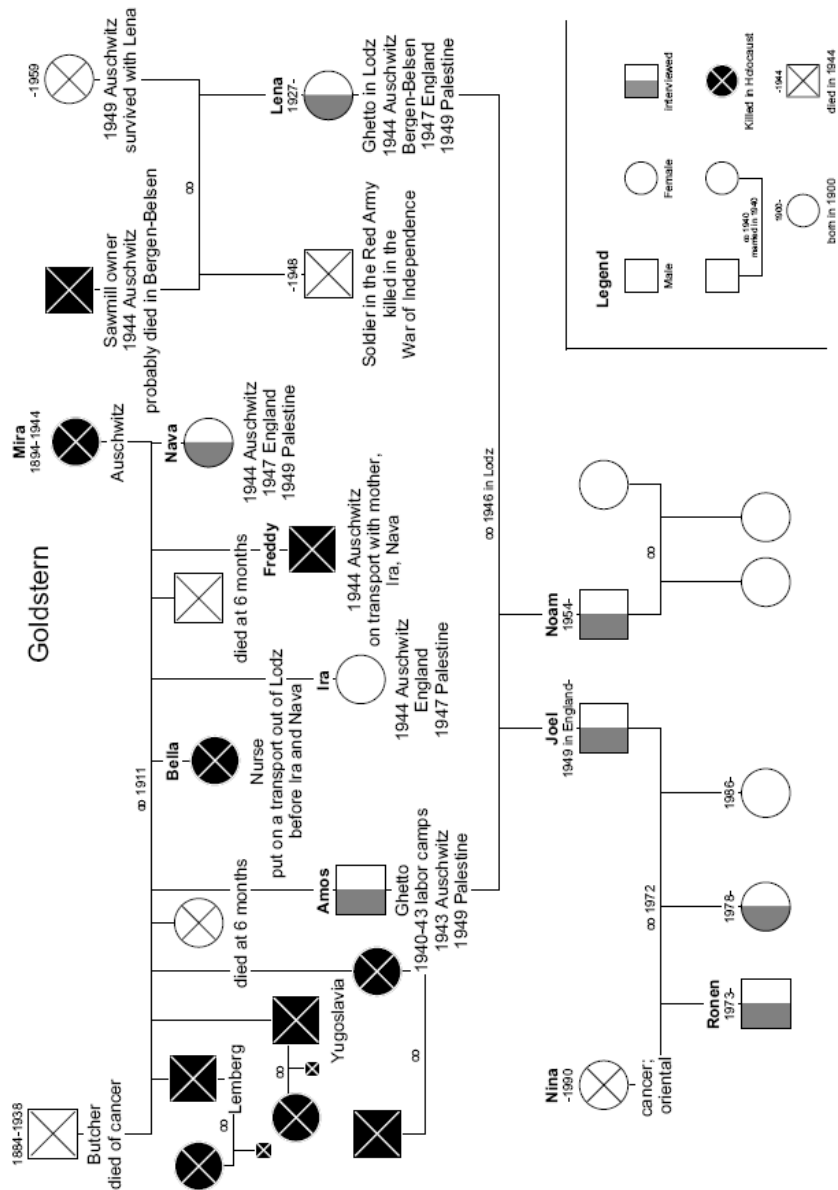

Figure 1: Genogram of the Goldstern family

Under cover of night, the two men let themselves fall into a ditch and, narrowly escaping shots fired by the SS, they ran away into the neighboring woods.

Of his seven siblings, only two sisters survived the Shoah. Amos also found out after the liberation, that his mother had been murdered in Auschwitz.

After the liberation, the first thing Amos did was to go back to Lodz to look for his family. There he met Lena, who had survived Auschwitz and other camps with her mother and Amos' sister Nava. Born in 1927, Lena is ten years younger than Amos. Thus, while Amos was already 22 years old when the period of persecution began in 1939, Lena was still a twelve-year-old child at the time. Lena's father owned a saw mill and was a member of the *Judenrat* (Jewish council) in the Lodz ghetto. In the family interview, she recounts: *"My father had a lot to do with Germans. ... They gave us a little house, near the office of the Germans"*.

This was presumably one of the reasons why she and her family were not put on a transport until the ghetto was liquidated in August 1944. Nonetheless, Lena and her family also suffered terribly from hunger and from the harsh living conditions in the ghetto. Her grandfather Joel, who lived with Lena's family, died of undernourishment in the ghetto. As a result, Lena still frequently talks about the starvation there even now and by doing so reminds Amos of the reasons why he left the ghetto. When Lena and her parents were eventually put on a transport, her father sensed what lay in store for them. Lena recalls that on the transport to Auschwitz he said: *"Now they're going to burn us"*. Lena's father did not survive his incarceration in the concentration camp. While Amos lost his mother and five siblings in the Shoah, Lena survived the camp with her mother. She, her mother, and Amos' sister Nava were liberated in Bergen-Belsen. Amos and Lena married in 1947 and, after spending two years in England, emigrated to Israel in 1949 with Amos' sisters and Lena's mother. Their eldest son Joel, named after Lena's grandfather, was born in England in 1949, and their second son Noam was born in Israel in 1954. Amos' two sisters also live with their families in Israel. Lena's mother lived with the Goldstern family until her death in 1954. Lena's significantly older brother emigrated to Palestine before World War II and was killed in action in 1948 in the War of Independence. Amos and Lena have an enlarged photograph of him in a prominent position in their living room, whereas they keep the unenlarged photos of their murdered parents packed away in a cupboard in their bedroom. There are another two large photographs of Lena's brother in uniform in their bedroom. Her brother is not just an important identification figure for Lena and Amos; their children and grandchildren identify with their uncle/great-uncle, too. An analysis of the interviews shows clearly that this identification serves the purpose of repairing strong feelings of powerlessness.

Whereas Amos<sup>32</sup> can talk obsessively for hours in great detail and chronological clarity about the persecution in his past, and in fact can hardly stop talking about it, Lena finds it very hard to talk about it.

As in quite a few other families, here, too, the man has taken on the role of the "veteran of Auschwitz", while his wife has assumed the role of the fragile, traumatized survivor who has to be protected from remembering. It becomes clear in the Goldstern family as well, that the past of the silent grandparent has a greater impact on the second generation's fantasies and development of symptoms than the past of the grandparent who talks about these experiences. And yet during the interview, we had a clear sense of Lena's desire to talk about the persecution she suffered. However, she could only speak more freely once her husband, who was present at the interview to start with, had left the room. Lena's life story is very fragmentary, and it is difficult to reconstruct the chronology from her presentation of the time when she was persecuted. It consists more of hints than clearly narrated stories. Whereas Amos tells many stories of his adroitness in the fight for survival, thus presenting himself as an active agent, Lena speaks mainly of memories that continue to haunt her today. She tells us that to this day she can still hear the children of the Lodz ghetto screaming: "*Don't give me to the Germans*". She has recurrent images in her mind of scenes where Germans threw small children out of the window onto open trucks waiting below. Lena was forced to witness how her sick girlfriend, who was in hospital at the time, was killed by being thrown out the window. These images haunt Lena to this day. To get a sense of the horrific reality that Lena's descriptions are part of, a brief account of the history of this ghetto seems appropriate at this point.

The Litzmannstadt ghetto, the first to be established by the Nazis and the last to be liquidated, plays a special role in the history of these ghettos. Chaim Rumkowski, the highly controversial Eldest of this ghetto, led it in a very authoritarian way and sought to save Jewish lives by cooperating with the Germans in all manner of ways. One of the most painful chapters in the history of this ghetto was what was known as the "*Kinderaktion*" ("Children Roundup"). In September 1942, when Lena was fifteen years old, the Germans demanded that all children under the age of ten be put on transports. All children up to the age of twelve had already been registered in April 1942 (cf. Bloom, 1949, p. 129). By this point, everyone in the ghetto knew what this meant, knew that these were transports to death. Rumkowski addressed the ghetto inhabitants, calling on them to send their children on transports the next morning to save the ghetto. The parents refused, and so a week-long curfew was imposed on the ghetto (from 5 - 12 September 1942). The Jewish police took 16,000 children, sick and old people from their homes and put

---

32 Gabriele Rosenthal interviewed Amos twice during the Gulf War in 1991. In 1994, Bettina Völter interviewed both him and this time Lena, too. All of the individual interviews with the couple were conducted in German.

them on transports (Hilberg 1990, Vol. 2, p. 542). The well-documented history of this ghetto - a chronicle of Lodz exists (Dabrowska & Dobroszycki 1965) - contains a great number of references to the murder of infants. One occasion on which such murders were committed, presumably the one Lena's memories refer to, was the liquidation of the hospital in September 1942 (cf. Gilbert, 1985, p. 440 ff.), one week after the so-called "*Kinderaktion*". In the course of this liquidation, infants, children, and frail people were thrown out of the hospital window on to trucks waiting below. Many of the children who were taken from the hospital and put on transports that day were not sick, but rather had been brought to the hospital because their parents thought that they would be safer there. Presumably Lena's friend was thrown out of the window during the evacuation of this hospital. Lena also talks about children being taken away from their parents during the curfew. In the family interview she goes further, revealing that a child entrusted to her mother was put on this transport of children.

Another of Lena's painful memories is being separated from her father at the ramp in Auschwitz, where the guards selected who would do forced labour and who would be killed immediately. She comforts herself with his last words to her mother: "*Look after her, she's all we have left*". She has good memories of her father and emphasizes repeatedly in the interview how much he spoiled her, saying: "*I was a child of cream and chocolate*". Lena initially lost her will to live in Auschwitz and wanted to take her own life by throwing herself at the electric fence. But her mother stopped her, and time and again, strengthened her courage to go on living.

Lena can barely describe the time that she spent in the death camp and later in the concentration camp in a chronological narrative. But she remembers everything vividly nonetheless and lives with a lot of horrific images that she cannot forget. One of the fragmentary stories she recounts, presumably from the time she spent in one of Auschwitz's outlying sub-camps, is this: she had come to the infirmary because she had collapsed and was given an injection there by a medical student. She says that this student was the son of a doctor and had pretended to be a qualified doctor to get out of being sent to the front. Lena says that her arm swelled up from the injection and her mother thought that she was dying. After this, she spent six or seven months in the infirmary. This story is still bound up with a great deal of fear, which can be sensed when Lena tells it. One of the things she says is that the "doctor" threatened to kill her if she screamed. Lena's story contains a lot of hints - particularly in reference to this doctor - and listening to her speak, one senses that more happened at the time than she can share with us now. Sexual violence emerges between the lines combined with gratitude towards this "doctor". We must bear in mind, too, that Lena may have been the victim of medical experiments.

Lena's memories of her time in the ghetto are linked to certain problems within the dynamics of her marriage to Amos. The pervasive theme expressed by Amos, who left the ghetto and his family on his own initiative, is that it was easier for him to survive in the camp than it was for those left behind in the ghetto: *"I was a lucky man being alone in the camp. I mean that I didn't have any family. The families were brought to Auschwitz, they were separated the children separate and the women separate. That was very tragic for the people. I only had to take care of myself."*

Amos feels guilty for going away, for the murder of his mother and his younger brothers and sisters. He feels guilty that he could not stand by them during the hard times in the ghetto. Their murder made his fight for survival seem meaningless at first. He says that it was *"the most awful moment"* in his life, when he came to Lodz and found out that his mother and siblings were dead: *"I said to myself (3) what did you fight for (2) what did you fight for? 'Cause I believed that someone-"*

Amos links his family's fate with Lena's family and life history. For him, she represents the suffering in the ghetto, which Amos considers harder than his suffering in the death and concentration camps: *"You know I was half a year in the ghetto, my wife was four years in the ghetto (3). When I came back (3) I heard what happened in the ghetto"*. At this point, Lena, who was present during the interview with Amos, adds something that clarifies her role in her relationship with Amos. She says: *"That's my work."* It is thus Lena's family biographical work to remember the time in the ghetto. Amos continues, saying: *"I heard what happened in the ghetto. Then I said (3) it's good I wasn't here. ... They imposed the curfew in the ghetto, they told the Elders of the Jews to round up the children"*. Lena adds: *"We had a friend, she was in the hospital, they threw her down from it"*.

We discover from the interview with Amos' sister Nava<sup>33</sup>, that Amos' younger sister Bella had worked in the hospital in the Lodz ghetto and had spoken on numerous occasions of newly-born babies being murdered. She was presumably put on a transport with the others when the hospital was liquidated. But Amos cannot talk about these parts of his family history, his theme is the fight for survival or his adroitness as an inmate. The aspects of his history of suffering, that he can talk about, are the active ones. The theme of "the murder of my mother and younger sister and brother Bella and Freddy" does not come into this thematic field.

We find out from Amos' sister Nava that she and her mother, her sister Ira and her brother Freddy were put on one of the last transports to Auschwitz in 1944. Her brother had tried to stop them from going. Nava recounts:

---

33 This interview was conducted by Bettina Völter in German and occasionally in English in 1994.

*"We were confined to the ghetto, every day transports left 'til they sent us away too. My brother said: "Mum I beg you not to leave, we can stay here, I know where we're going, I have a hiding place where we can stay". My mother said: "Don't be silly, we're going to work, I'm not afraid of work. We'll stay together, we'll work". He said: "Mum it isn't work (3) stay here". She said: "You know what, stay here". He said: "If you go I'm going with you" (3). I wish he'd stayed. 800 people stayed in the ghetto. I don't know if he would still be alive today. But he could have gone on living his life. And then we went away, too"*

Of the 800 people who hid themselves in the ghetto, one was a friend of Nava's who survived and lives in Israel today. Amos will have found this out from his sister. He says a number of times in a guilty tone that after the liberation he heaped reproaches on his sister Nava:

*"I wanted to find out what happened in the ghetto, why, how it was. She said ((Nava)): "Mother was taken on to the other side". I said: "Didn't you take her, why didn't you take her with you". She started to cry. I'd hurt the poor girl. 'Course I knew what that meant. But it's my mother, I wanted my mother back".*

*"I wanted my mother back",* Amos says and after the liberation it was very important for his emotional stability that Lena's mother took on the role of mother for him, as he says himself. Losing his mother is something that haunts Amos in his dreams to this day. For years after the liberation, Lena regularly had nervous breakdowns in the day, while Amos cried out loud for his mother at night. "Mama, Mama", he used to cry out, and Lena used to close the window, ashamed of what the neighbours would think. She always woke her husband up and tried to calm him down. Lena took on the role of the caring mother at night, while by day Amos tried to protect his wife from the after-effects of the persecution in their past. Thus in this family - as in other families of survivors -, the generations were shifted in a certain sense (Boszermeny-Nagy / Spark 1973). The reversal of the generational roles is continued in the Goldstern family in the way that the eldest son Joel assumes a parental role. As a father, Amos regularly thrashed his two sons Joel (born in 1949) and Noam (born in 1954) when they were children. His pent-up aggression, which occasionally vents itself, was something we interviewers could sense in the interviews with him: he became very verbally aggressive when certain themes were addressed. Amos survived four years in a number of different camps and, like other concentration camp inmates, he had to suppress his aggression during that time in order to survive. With some survivors, years of suppressing their aggression this way led to them bursting into fits of aggression at their children and even calling them Nazis (Wardi 1992). Some survivors unconsciously give their children the delegation to live out their own suppressed aggressions (cf. Solomon et al 1988).

### *The sons: struggling to separate*

Before we go into the interview with the eldest son in more detail, a few remarks about the similarities and differences between Joel and his brother Noam<sup>34</sup> may not be amiss here. The firstborn son, Joel, has the role in the family of the bound delegate, speaking to his parents every day on the telephone and visiting them often. This allows his brother to get out of caring for the parents' daily needs somewhat and to oppose them more, as well. Even as a child, Noam, who is five years younger than Joel, was the one who provoked the parents and fought with them.

Both sons stress that their parents almost never talked about the persecution in their past. In particular, they know almost nothing about their mother's past. However, a comparison of their interviews reveals, that Noam provides more details of the persecution in their past, asks more questions about it, and also takes on the perspective of his parents while they were being persecuted more than his brother does. Because, in comparison to his brother, he was more able to assume the role of the son who does not submit to parental authority so much, it is somewhat easier for him to look more closely at his parents' past. Even as a child, he used to imagine that he was in a concentration camp with his parents. He himself considers it masochistic that he was always trying to feel what his parents suffered: *"to know how they suffered to go into it and to try ... maybe to get into his ((his father's)) skin and to try to imagine what it was like or to try to experience what it was like"*. He talks about his father's escape in the last few days before the liberation, imagining how his father and his friend let themselves roll into the woods. He tries to physically feel what he thinks they must have felt, and in his imagination he hears and senses the guard dogs behind that had been set on him.

Noam's accounts of the time his father spent in the ghetto somewhat contradict those made by his father. He imagines that his father lived in the ghetto for a very long time. Using their imagination to try to heal the traumas of their parents is something that comes up again and again in interviews with children and grandchildren of survivors (cf. Samuel Stern, Chap. 2.5).

Noam speaks with embarrassment and a great deal of sensitivity about the persecution in his mother's past when she was a young girl:

*"I know she went through experiences that weren't very nice and maybe that's why she doesn't want to talk about them (4). Because she went through the Holocaust at a very young age, as a child of 14, 15, she really lost all her youth there ... at that age when she was becoming a woman, the experiences she went through weren't nice. ...Imagine a child who's an adolescent, imagine if you take a fourteen-year-old girl and stand her up take her clothes off*

---

34 Joel was interviewed by Tamar Zilberman in 1994 and Noam was interviewed by Yael Moore in 1996. Both interviews were conducted in Hebrew.



*and shave the hair off her head in front of a gang of lunatics. It's not exactly an experience that can leave a person sane".*

The image of how his mother and the other women in Auschwitz had to take their clothes off is one that he is especially preoccupied with. He says that this is one of the few things that his mother has told him, but adds that she has never gone into detail about it, presumably because she is ashamed of it. Perhaps Noam senses something of his mother's "shame-filled" experiences in the infirmary. But like his brother, he is afraid of finding out more about this past and admits quite openly: *"The truth is that I asked questions and got answers but I don't remember them".*

In adolescence, a fight he had with his mother once brought on one of her nervous breakdowns:

*"We had an argument, I don't remember what about and she lost her temper and collapsed on the bed, lay down and afterwards the whole story of the doctors came out ... she lost her temper with me in a very different way than usual. She beat me, too. I remember her lying in bed 'cause it hurt her that she had physically beaten me. I can't remember whether she fainted."*

His father was called home from work, the doctor had to be sent for, his mother was given sedatives and was in psychiatric care for a while afterwards. Noam vaguely remembers being beaten by his father in connection with this. He explicitly asserts in the interview that he refused to take the blame laid on him for the incident then and still does: *"I was blamed for it, but I didn't blame myself for it"*. However, his repeated justifications indicate how much this incident weighs on him:

*"I thought I wasn't the cause of this. I told them I'm not to blame for it. She has problems with her nerves, but you blame me but it's not me. Even now I still don't feel guilty about what happened 'cause I still know that it wasn't me ... she repressed it for X years and it had to come out"*.

While Noam openly expresses his protest against his parents, his brother suppresses the aggression he harbours particularly against his father in direct communication with his parents. Even in the interview with us, he finds it hard to talk about it. His loyalty to his father forbids him to tell us about how he was beaten by his father. His son Ronen tells us about this. On the other hand, Joel tells us about how much his brother was beaten. Noam, who talks about the thrashings his father gave him, justifies his father with the argument that he only hit them if he or his brother had made their mother angry, never because they had made him angry.

As adolescents, Joel and Noam perceived the overprotectiveness at home as an act of aggression by their parents. It was mainly expressed in forcing the children to eat. While Joel had a weight problem, and says that he was quite a

fat child, his brother says of himself: *"I was very thin. As a child I hated eating"*. Having been forced to eat is something that still haunts them today, and something both clearly connect to the persecution in the family past. Thus, Joel says: *"My parents were worried all the time about whether we were eating 'cause if we didn't eat we might die"*. Joel says that his brother was thrashed on numerous occasions for not wanting to eat: *"It's really unbelievable how much they beat him to make him eat. I remember that from my childhood"*. While Noam braved his father's thrashings, his elder brother "stuffed" himself with food, in acquiescence to his parental authority. We find traces of this being made to eat in connection with the theme of death with Joel's son Ronen. He tells us that he tried to breed chickens, but that they all died because of overfeeding. We must bear in mind, that his grandmother had to witness her grandfather starving to death in the ghetto and that Amos left his family, because he could not bear to see his mother go hungry any more. Thus, this specific aspect of the persecution can be seen to have had an inter-generational impact. The marks, that the persecution has left on the children and grandchildren, are not coincidental. On the contrary, they are expressions of specific problems in the respective life histories of the grandparents.

Both Joel and Noam still struggle in their lives for greater separation from their parents. Their life histories are an example of the considerable problems that many children of survivors have in separation-individuation (cf. Barocas & Barocas; Freyberg 1980). The brothers' desire for more distance from their family of origin is also expressed in their choice of partner. They both married women who were not from families of survivors. Joel married a woman from an Oriental Jewish family, and Noam's wife is from a family that has been living in Palestine for several generations. In 1990, Joel's wife died of cancer and presumably this bound him closer to his parents again. In contrast to Noam, he finds it very hard to separate his life history from his family history. This becomes manifest in the way he tells us his parents' reactions to his biographical decisions all the way through the interview, whether they were proud of him, or continued to worry about him even if they approved of the decisions he had made. His parents' past overshadows his own life to such an extent that his presentation of his own life history is noticeably shorter than that of his family past. Let us now proceed to a closer examination of Joel's biography.

### *The eldest son: "An unclear burden"*

At the time of the interview, Joel was 46 years old and had had a very successful career for many years as the manager of a well-known Israeli company. He himself attributes his professional success to his upbringing at home: *"The upbringing I got at home was to work the work ethic, to start*

*work at an early age, through the holidays to work hard. These are the values I was taught at home and the values of the army, that's what I'd say made me succeed".*

In 1990, Joel suffered a great personal loss: his wife died, just weeks after the doctors had diagnosed her as having cancer. Joel felt like his life had no meaning any more at first. But then he says that he decided he had to be strong especially because he had three children to take care of. His son Ronen was seventeen at the time, and his two daughters were twelve and four years old. The feeling that accompanies Joel through life is very strongly defined by a recurrent desire for greater distance to his parents and at the same time by the bond he has to them. By identifying very strongly with present- and future-oriented Israeli society, he tries to distance himself from his parents' Holocaust past. It was chiefly during adolescence that Joel's struggle for separation turned into a fight with his parents. On numerous occasions he had to face heated arguments if he wanted to take part in the trips that are so much a part of young Israelis' lives. These adolescent trips have become a symbol for the construction of an Israeli identity. It is thus hardly surprising that taking part in these trips was extremely important to young Joel and that these were the times when the symbol of belonging clashed with his parents' fears and overprotectiveness: *"There was not one trip that didn't cause arguments ... and crying, tears and threats and everything".*

When Joel reached the age of fourteen, he wanted to go on a trip with his friends from the Sea of Galilee to the Mediterranean Sea. This 'coast to coast trip', as it is known in Israel, has something of an initiation rite into the culture. But this time no matter how he begged and cried, his parents were adamant and Joel was not allowed to join his friends. This experience emphasized the way he was different from the other 'Sabra' children. It had such a strong impact on him that years later - when he was in his twenties -, after he had completed his military service, Joel made the 'coast to coast trip' alone and by doing so went through one of the main rites of passage to acquiring an Israeli identity. There was more conflict when Joel joined the army. Because he strongly identified with Israeli values, he chose to join the parachutist unit even though he knew that by doing so he would cause his parents a great deal of fear:

*"In short this overprotectiveness was an obsession with my parents, it was so strong that I would even say they tried to stop me from joining the parachutists and- even tried through some indirect connections. I fought with her ((with his mother)) it was clear to me that I was going to join the parachutists and that it was important for me to join the parachutists. I was very proud of it and I think that in the end my parents were very very proud that their son came back with 'wings' and a red beret and at the same time I tried to hide this subject from them, they didn't really know what was going on and how it happened, it was a secret until I just showed up with the red beret."*

As in his story of the 'coast to coast trip', a key conflict arises again here between his uncompromising wish to belong and to assume an Israeli identity (at the time the parachutist unit was a symbol of a proud new Israeli identity) and his desire to protect his parents from the fears that his aspirations generated in them. However, this protest was directed more at his father than at his mother. If, on a manifest level, Joel was opposing his father here, he was at the same time fulfilling his father's latent delegation by assuming the role of the fighter. By choosing to become an active fighter, he was emulating the part of his father's biography that was talked about over the years, namely, the part about actively surviving, rescuing others, and heroism.

Joel is one of those second generation Holocaust survivors who compare their own behaviour as soldiers in the Israeli army with the behaviour of the Nazis, sometimes even see or experience themselves in the role of perpetrator, and suffer greatly from guilt feelings. Joel, who fought in the Yom Kippur War and in the war in Lebanon, tells us that he knows exactly what dying and killing mean. He speaks of a comrade of his dying, and in front of his parents, says: *"I know exactly what is the meaning of killing and what is the meaning of to enter to houses and to search, to search and to look for somebody that is more or less the-, it is not the same of course but it is not far away"*<sup>35</sup>.

As for many soldiers who fought in the Lebanon War, this is the war that signifies moral issues for Joel: *"I felt like this German who come to search for Jews in the trenches and holes, houses- I certainly felt, a difficulty, there is a problem because you don't always know if it really is the house of a terrorist. There is a great difficulty to enter these houses, where some women is crying a heart-breaking cry and the children are just miserable, screaming and crying."*

Joel also speaks of situations in the war where he thought he would die. He always had two thoughts in such situations: How will my parents react after everything they have survived? What will happen to my son? These questions illustrate the role of the second generation very clearly: they have assumed the carer role for both their children and their parents. Dan Bar-On (1995, p. 45ff.) discusses a family, in which the desire of the second generation to take care of their parents is even stronger than the desire to take care of their children. How does Joel deal with his parents' past? He says that his parents have hardly spoken to him about the persecution in their past. Nonetheless, Joel recalls a situation that he remembers as being traumatic. He was around thirteen years old when his father showed him all of the photographs taken by the Allies after they liberated the camp: *"I saw these pictures- it was very frightening but right afterwards they hid them away, they put them in some locked drawer there you couldn't open."*

---

35 This is the original English; the quote was taken from the family interview (cf. Chap. 6.1)

In the interview, Joel reduces his father's experiences down to this statement: *"He was in Auschwitz, suffered terribly and survived"*. Joel knows the facts, who was murdered and who survived and in some cases knows which camps his parents were in. It can be said of the parents that they both live very much in the past, along the lines of J. Lomranz et al (1985). However, while the mother's story is suppressed and goes untold, the father's story is the one that is given space in this family. Nevertheless, the father's story is not told in its entirety; he only tells the parts that reflect strength where he rescued others and escaped. Amos selects certain aspects from his life history that create a life story in which he is primarily an active agent. This pattern of selecting certain aspects is reflected in his son Joel's life story as well. In his life story, Joel emphasizes the strong, rebellious, active aspects and suppresses the aspects that reflect fear, weakness, and helplessness. Even if his parents have hardly spoken to him about the atrocious events they experienced, the mark that the persecution in his parents' past left was ever-present for him and his brother. Joel expresses this as follows: *"It was a life in a house that is the Shoah, with some envelope containing pictures hidden deep deep in- .."*

Joel grew up with his father crying out *"Mama, Mama"* at night, and his mother waking him and calming him down. But he tried, as he puts it, to play deaf and when the subject came up: *"I tried not to be part of these conversations. I always tried to sit in the corner, to put up some kind of barrier, not to hear."*

His father's cries of *"Mama, Mama"* also confronted Joel with his mother's trauma. He would have to have been deaf not to hear the screaming in the night. His father was screaming for his lost mother. Thus, Joel's mother had to be his father's mother, too, and the son developed aggression towards the father. In his family sculpture, Joel places his father between himself and his mother. Thus, the father is between mother and son.

Even as a child, he experienced how his mother had repeated nervous breakdowns as an after-effect of the persecution. He says that his childhood was not a normal one, that his parents always provided for him amply in terms of material things, but stopped him from doing many of the things he wanted to do because of their fearfulness and that they were unable to give him any joy.

Joel lives so much in the shadow of this past that to some degree he has had to split off from it emotionally. Thus, in the interview it is striking that in connection with the Shoah, he speaks repeatedly of *"Ha-esek Haze"*, of *"this subject"*. He also says: *"I've tried to suppress this subject maybe even 'til today"*.

The heavy burden that the persecution in his parents' past has placed on him has led to him doing all he can to close himself off from it. To prevent the threat that emanates from this past from becoming overpowering, he tries to identify with Israel's past. One way in which he does this in the interview is

by emphasizing again and again that the Memorial Day to Fallen Soldiers (*Yom Hazikaron Lechalaley Zahal*) is more important to him than the Memorial Day to the Shoah and Heroism (*Yom HaShoah veHagevurah*). Both of these memorial days are commemorated within one week. Referring to the second Memorial Day, to the Shoah and Heroism, Joel argues: *"For me this day is very- the symbol of the Memorial Day to Fallen Soldiers, comparing it to the Shoah Day for example, that does nothing for me, absolutely nothing"*.

He speaks again and again in this connection of his uncle, Lena's brother, who was killed in action in the War of Independence in 1948. His uncle is someone he can identify with, unlike the members of his family who were murdered in the Holocaust. He uses this uncle to try to establish continuity with the family past: *"Till this day we go every year to the grave ((the uncle who died in 1948)) on the Memorial Day to Fallen Soldiers. I and my brother see it as a kind of continuity."* These emotions and responses are completely different to those he expresses towards his relatives who were murdered in the Holocaust. He neither mentions their names nor tells any stories about them but merely states their number.

But there have been times in Joel's life, when aspects of the persecution in his parents' past, that he has split off, have become a theme for him and have sometimes even completely overwhelmed him. Thus he says: *"When I was young I played the tough guy. Maybe in the past few years I've started falling to pieces - even crying- my falling to pieces started when I was in Bergen Belsen"*.

This process started when he was sent into the war in Lebanon (1982-1984). This set off the first of his nervous breakdowns which reached their peak in 1988 when he went to the memorial of the Bergen-Belsen concentration camp where his mother and grandmother were incarcerated last, and flared up again after his wife died. In Bergen-Belsen, the latent stratum that he had suppressed all his life surfaced and overwhelmed him. He tells of how he broke down at the entrance to the memorial and could not go inside the former camp at first. All of the images, that he had tried not to imagine on the Memorial Day to the Shoah and Heroism, now flooded into his mind: *"I had a kind of flashback from Shoah movies that I would say that I saw. I didn't see many, this is also an issue that is in the framework of suppression I tried on the Shoah Day not to see, to ignore it"*.

His legs began to shake, and it took nearly half an hour before he could go into the camp. He repeated to himself over and over: *"...but my parents-"* and then with trembling legs he stepped inside the camp. He describes the symptoms that he experienced while he was there. He started to shiver, to cry and as he put it:

*"I think I broke down then and I suddenly felt (5) what- what a load I'd been carrying and- a kind of a ((cough)) kind of unclear burden that for years you absorb silence and you ((coughs)) put up a wall, you don't hear*

*((cough)) try to ignore not to live it and suddenly you find yourself in a situation where you- have to visit the place".*

His mother's untold story came up in Bergen-Belsen, and so did her symptoms. When asked earlier in the interview about how he reacted to his mother's breakdowns, he replied: *"I closed myself off and... like an ostrich you could say, I put up a wall around myself uh .... I don't remember crying in my whole life..."* In Bergen-Belsen, this defence mechanism broke down, and Joel had a nervous breakdown of the kind he had seen his mother having on numerous occasions, and he began to cry desperately. For the first time, in Bergen-Belsen, he had images of his mother being in the camp. He found it hard to put the images he saw into words. The interviewer asked him several times about the fantasies that he had in the camp, and it was only after a few attempts that he managed to reply that he had imagined scenes of fear and helplessness. Joel has considerable difficulty putting these scenes into words, and we can interpret this as expressing that while the symptoms were transferred to him from his mother, the words were not. This is what Titchener (1967) describes as unconscious messages that are transported to the next generations and that have a considerably stronger impact on them than messages that are manifestly transferred.

After the death of his wife, he fell into a profound sense of hopelessness, and through it, began to understand better the feeling that accompanied his parents through life. But he adds that it is a mystery to him, how his parents and other survivors can even go on living with this feeling. Joel argues that "living with the Holocaust" has made him a closed man who always hides his emotions. Just as he cannot talk to his parents about emotions, so he is unable to communicate with his son about them. Joel projects his own "deafness" towards his parents' past on to his son:

*"I think my children are in the same situation that they're actually totally unfamiliar with the subject. It would have been very convenient for me if my father had sat down with my children and told them what he went through 'cause I think it's important that the next generation knows what really happened. It was easier for me not to hear these things 'cause I find it hard to live the- near these things".*

While Joel relates his children's lack of knowledge back to his own problems, at the same time he accuses his children of not being interested in this subject. This is the very same mechanism that operates in his relationship to his own father (cf. Chap. 6.1).

How does Ronen, a member of the third generation, see this subject? How does he see his relationship with his father and grandparents and the communication in his family?

*The grandson: "The emotional issue is an issue all of its own, a mystery"*

Ronen Goldstern<sup>36</sup>, the son of Joel and grandson of Lena and Amos, was born in 1973 in Israel during the Yom Kippur War while his father was away on the battlefield. Ronen sees a parallel here to something that happened in the past:

- Ronen: "...and then the Yom Kippur War started, I was born and the whole story uh (2) this story that repeats itself..  
Interviewer: What story that repeats itself?  
Ronen: Father in the war, mother with the child and grandfather and grandmother bringing everyone up and and (10) and that it..."

This answer with its stops and starts and its conspicuously long pause of ten seconds about a story that repeats itself of a father in the war, a mother who stays behind with the child, and grandparents who raise the child refers to the traumatic family theme of the Goldstern grandparents. However, we must also see these remarks against the background of Ronen's own traumatic loss of his mother, who died when he was seventeen years old. This loss marks a traumatic turning point in his life. Ronen separates his life before his mother's death from his life after it: *"It was just an ordinary life, I don't know (2) I didn't have (2) any ups and downs in my life 'til I was seventeen (3) and that's it. When I was seventeen my mother died (2). So that closed a chapter in my life (3) and that's it. I mean, everybody started another chapter, I don't - mmm, I stayed there"*.

Ronen says that his mother's death closed a chapter in his life. He tries to block out his memories of his mother and to split off his grief. One effect this has is that he can hardly remember things he experienced before his mother's death. In the interview with Ronen, it emerges very clearly that, after his mother died, he behaved according to the family pattern of suppressing sorrow and making a show of strength in situations of loss. He concentrated on his final examinations at school and, as he puts it, on functioning:

*"I don't remember basic things... I don't know from the moment she died (2) I don't know I had final exams then. There are many things I don't understand, apparently that's part of my upbringing that- I don't know, it's over and (1) she died and that put an end to it. I mean something stopped but, I went on moving with the stream I mean uh nooo (6) I didn't think about things deeply and and I think that was part of my mistake I mean uh- (1).*

---

36 Ronen was interviewed by Noga Gilad and Hagit Lifshitz in 1995. The interview was conducted in Hebrew.



Ronen sees the connection to his upbringing himself, and we can assume that this family pattern is partially due to the persecution in his grandparents' past. His grandfather's latent delegation to fight is connected to this past, too. One year after his mother died, Ronen joined an elite unit of the Israeli army: the *Mista'arevim* unit, whose members are sent into the occupied territories disguised as Palestinians; one of their assignments is to murder specific people.

Although on a manifest level both his grandfather and his father disapprove of his taking part in this elite task force, which they compare to the Nazis, at the same time they support his choice. Speaking of Ronen in an appreciative tone, his father says:

*"I have a son in the army who didn't fall far from the tree. He went, even though he could have used his privilege of not going and joining a special unit 'cause he lost his mother at an early age and could have stayed close to home. And nonetheless and not 'cause of my encouragement but because he had a home where children were raised to have values."*

For Ronen, the values shared by his family also involve not showing one's feelings. He speaks about the emotional difficulties in his family, above all in relation to his father, saying: *"The emotional issue is an issue all of its own, a mystery."* He says that his father passed on his grandparents' values to him, those of suppressing feelings and keeping problems to oneself. Ronen is afraid that one day he may have the same problems with his own children that his father has now: *"My worst fear is how to act with a child. Because I don't have- I have nothing I can pass on. I have the negative behaviour that is- that's the only way I know to behave with children"*.

How does Ronen deal with the persecution in the past of his grandparents, Amos and Lena? What is initially striking is that the way he presents their life before the persecution is very similar to the way he presents his own life before his mother's death: *"My grandfather and grandmother were born in Poland, they lived in Lodz and, that is I mean until 1939 they had an ordinary life..."*.

The parallel that Ronen draws between his own traumatic loss and the persecution in his grandparents' past emerges in a number of sequences in the interview. Ronen repeatedly compares his suffering with the suffering of his grandparents. He infers his right to doubt the existence of God from his own suffering:

*"All the time, there=there's one thing that (1) my grandfather all the time I told him I don't believe in God (3) ...because of what happened in the Holocaust ... it used to be on my mind a lot, he used to tell me I have no right to say that ... I wasn't there and I have no right."*

He subsequently compares the world "there" with the loss of his mother: *"When my mother died I asked him can I now? (1) Now I have the right to*

say there's no God I mean- (6)" Ronen sees himself in the role of the survivor and connects this to his role as aggressor in the occupied territories:

*"The moment the person closest to you dies, then, whoever else around me dies is already not, it's not the same thing I mean uh- ... Let's put it this way because, I lost a lot of humanness in that regard in the territories. I just lost what I used to believe in. You lose your humanness a, a=a a hundred percent I mean you're not, you're not human, even the strongest people there."*

Losing "your humanness" is an archaic expression that has become very loaded since the Shoah and is now only used in the context of people in camps. This expression has come to describe their struggle not only to survive but also to keep their "humanness". Ronen links the Shoah and the role of victim with his army service and the role of aggressor. Even the strongest people can lose their humanness and can even become aggressors. Is he thinking of his grandfather in this connection? If we bear in mind that his statements were made in relation to his dialogue with his grandfather, they suggest the assumption that victims of persecution can become aggressors. Ronen's argumentational figure here is that both the losses suffered by the Jews in the Holocaust and the early loss of his mother have made other deaths unimportant for him and made him lose his faith in God and in humanness. Whether he is unconsciously linking the murder of Amos' mother or the violent death of Lena's father to this is something his remarks leave open. Like his father, he does not want to go into this further. And like his father, he only speaks of the murdered members of his family and the powerlessness and helplessness of being persecuted in a few sentences. He, too, concentrates on the version passed on by his grandfather, the story of active deeds, escape and heroism. For instance, he tells the story of how his grandfather stole some gold coins to rescue himself and a good friend of his. After this, he argues:

*"I was more interested in this point of going like sheep to slaughter, I never reconciled with this point (2) in eleventh grade there was a delegation to Poland and I went with them (2).....it was only then that I understood that the real battle was a battle for existence no more than that not about escaping and (2) from the Warsaw ghetto you could see how successful the uprising there was it's not exactly uh (8)."*

Straight after this sequence, he tells a detailed version of the story of how his grandfather saved himself and his best friend. Ronen is preoccupied with the story, that he has been told, and with its messages of activism and heroism.

But Ronen also constantly has fantasies about the family's untold stories and acts them out in a number of ways. He argues that all he can remember about his childhood are stories about wounds, injuries, and diseases. He says that he suffered from fear of heights and claustrophobia. It was striking in the

interview that Ronen claimed he could hardly remember anything that happened in his childhood, but he did remember the following situation: when he was a small boy, his aunt wanted to cure him of his fear of heights. She took him out on to a balcony, held him up by the legs, and shook him in the air and pretended she was going to drop him over. Ronen evaluates this memory as follows: *"it is strange...she ((the aunt)) is a person that I felt good with..."* We might ask ourselves at this point whether there is a connection between Ronen's phobia and the untold story of his grandmother's: that of throwing children out of the window in the ghetto of Lodz?

Ronen had serious problems with phobias during his time in the army, too. Whenever he was in a closed armoured vehicle and did not know where he was or where he was going to, he used to purposely fall asleep *"to be unconscious"*:

*"It started with the armoured vehicle in the army, that I used to sit down there and not knowing my orientation used to drive me crazy, I mean feeling sick and headaches. I didn't know what to do with myself. I used to fall asleep on purpose so as not to be conscious there. Afterwards I had the same thing with tanks apparently the suffocation and the dark, plus the fact that you don't know where are you at all."*

Another problem he had during the army time was that he could not climb guard towers.

On one hand, Ronen has strong fears and on the other, he seems to go out of his way to put himself in dangerous situations. He seeks danger for danger's sake. We can either interpret this as a defence mechanism against his own fears or against the fears of his overprotective grandparents. Ronen really tested the boundaries between life and death around the time his mother died:

*"As far as accidents and things like that are concerned, I used to test myself a lot, in the time between the army and my mother dying (1) and doing crazy things in the car and all kinds of things like that, driving into intersections at crazy speeds (6)... I don't know like a person who's not really conscious"*.

Another way Ronen dealt with the issue of death was by joining the *Mista'arevim* unit in the army: *"In the army, there were very few moments when I felt I wasn't in danger of dying... But on the other hand it served a need to overcome obstacles and to survive"*.

Like his father, Ronen also tries to put some distance between himself and his Holocaust past by orienting himself on the Israeli ideal of the fighter-soldier. He, too, attributes more importance to the Memorial Day to Fallen Soldiers: *"Today I can say clearly, the Memorial Day to Fallen Soldiers is much closer to me than the Memorial Day to the Shoah and Heroism"*.

This is a way for both him and his father to deal with issues of death and mourning, which are central issues in this family, through a symbolic day that allows them to avoid dealing with the painful details behind the symbol. This symbol allows the son and grandson to link the delegation to fight with their actual life histories. At the same time, they try to separate their lives from the past of the Shoah and the untold, but very much sensed, experiences of powerlessness and helplessness. Through their professional activism and by becoming fighters, they try to heal the helplessness that their parents and grandparents, resp., suffered. In the process, the grandson in particular finds himself in a moral conflict. Ronen fights with serious guilt feelings in connection with his "military" operations. The dual role of victim and aggressor is both confusing and threatening for him. And yet it is worth recalling here that he experiences his grandparents in this dual role as well. On the one hand, they are victims who need to be protected, and on the other, in certain situations they are aggressors. Ronen knows the stories about Amos beating his sons; he says that when his father was a child his grandfather beat him with a belt. He reflects on the way he himself acts out suppressed aggression: *"I fly into fits of rage a lot and, it's not, not really clear, until I actually have them, I can suddenly lose it, just about little things as if, and I fly off the handle"*.

As we have seen, Joel repressed his own aggressive impulses because of the dual role of his father, who on the one hand needed to be protected, who cried out for his lost mother at night, and on the other, was aggressive. This family biographical constellation can lead to later generations struggling between the two extremes of passively enduring and active defending themselves. Taking part in military operations in the wars in Israel only served to heighten this role confusion. In addition, the operations in the Lebanon War and in the occupied territories brought moral conflicts in their wake. The grandchildren, who received part of the military socialization within this framework, suffer from such moral conflicts far more than the generation of their fathers did (cf. the Stern family 2.5).

Ronen goes a long way to confronting the effects of the persecution in his grandparents' past on his family. The generational distance allows him to look more closely than his father can at this past<sup>37</sup>. Also, he did not have to take on responsibility for the grandparents like his father did, and so harbours no aggressions against them and can open up to them more freely. In the same way, it is sometimes easier for grandparents to establish closer relationships with their grandchildren. The generational proximity of the first generation and their children means that the second generation has a very complex relationship to their parents, one that is very often mixed with feelings of obligation, mutual overprotectiveness, suppressed anger and guilt feelings. Despite, or

---

37 Carter and McGoldrick (1988) have observed a similar phenomenon in the generation of the grandchildren of emigrants to the USA: they feel secure enough in their "national" identity to look more closely at their grandparents' pre-emigration past.

rather because of this proximity, these relationships lack the openness characteristic of grandparents-grandchildren relationships (cf. Dasberg 1993). With their grandchildren, the grandparents are able to satisfy their longing for a sense of continuity (Lomranz 1990, p.113). For them, knowing, that some continuity to their murdered family members exists, gives meaning to the suffering they went through to survive and eases their feelings of guilt for staying alive. This desire for continuity and the significance of children for Amos and particularly for Lena Goldstern has a special meaning as the trauma of the murdered children of the Lodz ghetto is definitive for the family dialogue (cf. Chap. 6.1). Moreover, the generational distance gives the grandparents a chance to relive their experience of parenthood with their grandchildren while at the same time allowing them to reconcile themselves with the mistakes of the past. This can repair their experience of having been inadequate parents. For grandparents who are survivors, this feeling is often even stronger as their parenting was done in an atmosphere of mourning and loss. This sense of repairing the past is partially due to seeing that their grandchildren are healthy and "normal" which in turn vouches for the "normalness" of the grandparents. For Ronen, his grandfather is the main person who has become important to him as someone he can talk to: *"If I talk to anybody it's my grandfather I mean uh (2) we're pretty good friends, I mean uh, we have no problem talking to each other for a long time and (6) that's it and he feels comfortable talking to me 'cause I'm more open"*.

Ronen's relationship to his grandfather is more open than to his father, and part of the reason for this is that his grandfather has no problems letting him go. Ronen accuses his father of not allowing him to separate from him:

*"My father, apparently 'cause he hasn't grown up enough, so he needs me alone, he can't accept me being with anyone else, I'm 22 years old and he needs me alone, but, I wish when he needed me and I come that he would then sit down and talk to me, but what happens is he talks to me for two minutes and goes back to his jobs"*

Ronen's communication with his father is full of misunderstandings, accusations, and pain. Just like Joel, Ronen rebels and closes himself off, but at the same time tries to fulfil his father's expectations. It is extremely important to him to please his father and gain his love. He speaks with longing and pain of moments when his father has stood by him and supported him. He says that family is the most important thing anyone can have in life.



## 7. Surviving as inmate-functionaries: The Shapiro/Sneidler family

*Three sisters who survived in very different situations: Ariela, Rebecca and Edna Shapiro*

Noga Gilad and Gabriele Rosenthal

While the three sisters in the Genzor family (2.2) survived their time in the camp together, in the Shapiro family we interviewed three sisters who survived in camps separately and suffered very different fates.

The Shapiro family lived in Carpatho-Ukraine, an area that belonged to Hungary until World War I, was then made part of Czechoslovakia, and was given back to Hungary in March 1939. After World War II, the region was annexed by the Soviet Union. About 15% of the population were Jews, roughly half were Ukrainians, and a third were Hungarians (Encyclopedia 1995, p. 1419). The Jewish men of Carpatho-Ukraine were sent to forced-labour camps from 1941 onwards, among them the sons of the Shapiro family. Deportations to the annihilation and concentration camps only got underway after the German occupation of Hungary in March 1944. Only 20% of the Jews from Carpatho-Ukraine survived persecution. Most of the survivors decided to leave the region after the Soviet Union had annexed it, emigrating to Israel and other countries after a brief stay in Bohemia (ibid, p. 1421).

Of the six sons and four daughters in the Shapiro family, nine children survived the Shoah. This is something that the three sisters, Ariela, Rebecca and Edna, repeatedly emphasized in the interview. They see it as a sign that they are a blessed family, protected by God. Rebecca says: *"We're the only family in the world where nine out of ten children came back."*

The family's eldest child in the family, Saul, was born in 1909 and the youngest, Eva, in 1925. Eva and her parents did not survive the persecution.

The family history before persecution

The Shapiro sisters<sup>38</sup> parents came from Budapest and Bratislava to Carpatho-Ukraine at the turn of the century. Their father, a qualified accountant

---

38 Ariela Dgani, Rebecca Sneidler and Edna Har-Zvi were interviewed by Noga Gilad in 1993-4 in Hebrew.

from Bratislava, worked on the estate of an Austrian prince. Both parents immigrated to this multi-cultural region from the developed "heart" of the Austro-Hungarian Empire. The family identified with German culture and liberal European Judaism. Their mother was socially and politically active in WIZO (Women's International Zionist Organisation). The parents managed to give their four eldest children, three sons and Ariela a university education.

Ariela (born in 1912) finished high school and went on to study German and Czech in Bratislava. Of the three sisters, she is considered the intellectual, and the clever one. After her marriage, she lived in her husband's hometown in Hungary and gave birth to a son in 1941. During this period, she worked as a seamstress. In the interview with her, we discovered very little about this phase of her life before Auschwitz. She lost her son at the ramp in Auschwitz-Birkenau, and her husband did not survive the camps.

Rebecca was born in 1918 and as the sixth child, she was the middle one in the family. She tells us that she and her younger siblings had far less schooling than the elder children. She still recalls warm, hearty Sabbath evenings at the family table. While the elder daughter Ariela served the parents and the five older children, Rebecca served the five younger children at table. They joked about "the lower class" and "the upper class", dividing Rebecca from her five elder siblings. All three sisters explain the difference between the elder ones and the younger ones as one of age and education. But Rebecca found a way out of her "inferior position" in the family hierarchy of looking after the others. In the triad of sisters, Rebecca took on the role of the pretty one. She tells us: *"They always said they had to marry off Ariela 'cause Rebecca's growing up, and I was prettier."*

Rebecca and her siblings received some schooling from their mother, who prized German literature and poetry very highly. Rebecca is still able to recite a number of the poems that her mother taught her. But she has very ambivalent feelings about doing so and about speaking German in general. She tells us how, in an act of revenge, she burned the German books of a German doctor who had left Czechoslovakia, shortly after the liberation. To this day, she wishes she had kept these books.

When the German *Wehrmacht* invaded in March 1944, Rebecca was staying with her sister-in-law in Ushgorod, the Carpathian capital. She was there to help deliver her sister-in-law's baby. They were taken to the city ghetto together in April 1944 (cf. Sdei-Ur 1994). Rebecca talks mainly about how hard it was with the newborn baby, whom she felt co-responsible for. She, her sister-in-law and the baby were put on a transport to Auschwitz together. Rebecca was engaged to be married; her fiancé did not survive persecution.

Edna was born in 1920, two years after Rebecca, and shares many of her childhood memories. Edna paints a disparaging portrait of herself as a young child, depicting herself as a spoiled and weak girl, who had problems with



self-esteem, and longed for her parents' affection. She, too, speaks of her mother's love of German culture and of her father, whose motto in life was: "A sound mind in a sound body". In the interview with Edna, we get a sense of her competitiveness with Rebecca. Edna feels inferior to her sister and feels forced into the role of the "little sister".

Edna was taken to the ghetto in Munkacs with her parents and her younger siblings and from there was also put on a transport to Auschwitz.

### Surviving in Auschwitz and other camps

Arrivals at Auschwitz were divided into those who were allowed to live for the time being and those who were to die immediately. This was a crucial moment, as the guards selected those on the ramp who were considered 'worthy of life' - the young and healthy ones - from those who were not - the children, the sick and the elderly - who were immediately gassed and their bodies burned. For all three sisters, Ariela, Rebecca and Edna, this selection procedure on the ramp at Auschwitz was one of the most painful things they experienced during the persecution. All three women lost their closest relatives in this procedure. Edna was the first of the three sisters to arrive at Auschwitz with her parents, her youngest brother Nathan and her sister Eva in 1944. She was separated from her father, her brother and her mother on the ramp at Auschwitz. She never saw her parents again. Her sister did not survive the camp. Ariela arrived at Auschwitz with her parents-in-law, her husband and her three-year-old son. Her son and her parents-in-law were murdered right after their arrival at Auschwitz. Her husband survived in the camp for a while, but was later murdered in a forced-labour camp in Germany. Rebecca went through a traumatic separation from close relatives at Auschwitz-Birkenau, too, in June 1944. She was put on a transport with her sister-in-law and the baby, both of whom were murdered in the gas chamber. How do these three sisters talk about these traumatic separations now, and what did they go through in the annihilation and concentration camps?

Ariela speaks of the traumatic separation from her three-year-old son at Auschwitz:

*"We arrived at Auschwitz, when I got off the train, the doors were opened, there were already inmates in striped uniforms. One said in Yiddish that I should give the child to his grandmother, because if I worked there would be something for his grandmother and me to live on. It was a lie. I believed it, everyone clutches at straws, I actually gave him ((her son)) to his grandmother, three times I ran back to get him, until I was standing in front of Dr. Mengele, he asked whose child is this, the grandmother took him and a good friend of mine with a small nine-year-old they took the child. He ((her son)) called out to me to come back, the child called out, I was glad someone had taken him I didn't have the strength, we hadn't eaten during the journey,*

*I don't know for how many days, there was no food there was no water, we were a mess all of us, until we got off ((the train)), it was good a bit of air, 'cause there were no windows... before we even arrived at Auschwitz some had fallen asleep forever, some young ones like myself somehow reached Dr. Mengele, and he separated us, my husband was still saying, just before that, 'don't forget to give the child to mama', and later when we had passed through this procedure, we met, just for a minute, he said 'it's too bad you gave him to her maybe you can still get him back', that's what he said, I was stupid."*

This traumatic separation from her three-year-old son has stayed with Ariela all her life and, time and again, has weakened her will and courage to live. She reproaches herself, accuses herself of stupidity and ignorance for not knowing what they were being selected for at the ramp. In the interview, Ariela repeatedly expressed her wish to die and talked about her quarrel with God for allowing her child to be murdered. Despite this quarrel, she says that she is grateful to God for her own survival:

*"Later something happened I felt special powers looking after me, in the most difficult conditions, I didn't want to, something happened, I sensed that someone is pushing me along, and taking care of me, I could tell because I'm religious, even though I was completely free, do you understand?"*

Today, Ariela is the most religious of the sisters.

Ariela was in Auschwitz-Birkenau for three months. She was able to better her situation there somewhat by doing tailoring and sewing work for a female SS guard. She says that every day the SS guard had a blouse sewn for a Jewish woman whom she was presumably having a lesbian relationship with, and who lived with her in the barracks. Ariela was given bread in exchange for her work. In October 1944, Ariela was transported from Auschwitz to a forced-labour camp near Breslau. Towards the end of the war, members of the *Volkssturm*, the "people's army"<sup>39</sup>, were sent there as guards. Ariela got to know one of them, a 52-year-old German from Breslau, who helped her in the weeks that followed. He regularly slipped her food. It was primarily thanks to his help that she survived the death march to the Gross Rosen concentration camp. In her conversations with him, she got to know a German who was different than the others whom she had only known until then as persecutors. He gave her the feeling that there were Germans who did not strip her of her humanness because she was Jewish. She tells of her parting from him:

---

39 On 25 September 1944, Adolf Hitler decreed that all men of German citizenship between the ages of 16-60 were to be conscripted to serve in the *Volkssturm* to "defend their native soil".

*"We were brought to Gross Rosen, it was a notorious camp, a huge camp, with an electric barbed wire fence. My guard hadn't believed me when I told him that they'd taken my child, but here he believed me. He had to stay outside, we cried, we parted and I never saw him again."*

She still speaks with deep gratitude of this man, whom she refers to as "my guard", and asked us to make contact with him or his children. She regrets never having written to him. She tells us that there are two things in her life that she has left undone: thanking this man and visiting the grave of her first husband, who was buried in Germany.

From Gross Rosen, she was put on a transport to Bergen-Belsen, where she was liberated in April 1945.

Let us turn now to the middle sister, Rebecca. She arrived at Auschwitz with her sister-in-law and the baby:

*"When we arrived at Auschwitz, the train was opened so fast, it's impossible to describe, we were left empty-handed, everyone was. I got out with just whatever I was wearing, my sister-in-law got out with the baby and a little pillow. And before we knew it we were lined up, men separate, women separate, and were standing in front of Mengele. I remember how he stood with his legs apart, with a stick in his hand and a giant dog, and was already doing left-right. When our turn came he asked 'whose baby is it' in German, and we both answered 'mine' [in German], so he asked 'who's the mother?' And then my sister-in-law said she was the mother, so he ordered me to give her the child, and when I gave her the child then, and she had a pillow in her hand he gave her such a kick with his leg that the pillow fell on the ground, and so he ordered her to go left and I tried to catch my sister-in-law's eye to look good-bye, because right and left, I didn't know what else would happen but I tried to catch her eye to say good-bye, but our eyes never met again in this life, she looked at the ground with great pain at the pillow that was on the ground and the child that was left in her arms with nothing and she went. I never saw her again in my life"*

While Ariela has to live with the trauma of her child having been murdered, Rebecca feels guilty for surviving because she had no child, as opposed to her sister-in-law who perished. This experience is a painful one which the two sisters have in common but which divides them at the same time. In the joint interview with both of them<sup>40</sup>, Rebecca asked her sister to tell the German interviewer about the persecution in her past and repeatedly emphasized that Ariela had suffered more than she had. However, Rebecca could barely listen to what her sister was saying, but rather kept escaping from the interview to

---

40 This interview was conducted by Gabriele Rosenthal and Noga Gilad in 1996. Ariela primarily spoke German with G. Rosenthal, while Rebecca sometimes spoke Hebrew in parallel discussions with N. Gilad.

do jobs around the house. Ariela's trauma triggered her own traumatic experiences. And yet it was important to Rebecca that this part of the persecution in their past be told by Ariela, and to the German interviewer in particular. Rebecca was also the one who insisted that her younger sister Edna be interviewed. She wanted to be present at this interview, because she had never allowed Edna to tell her how their youngest sister Eva died and how the two of them were separated from their parents. While Edna was telling the story of what happened, Rebecca could barely allow herself to cry. Here again, she began to busy herself with housework. As we will see below, her daughter uses a very similar defence mechanism in the family interview.

What did Rebecca go through herself in the camp? Shortly after her arrival in Birkenau, she met her younger sister Edna who was working in the Canada commando. This was "concentration-camp jargon for the warehouse area at Birkenau where all clothing and food confiscated from incoming inmates was sorted, prepared, and stored." (Linden 1993, p. 167). Edna had heard, that a transport from Ushgorod had arrived, and she was on the lookout for her sister. To be allowed to do this, she had to bribe an SS guard with a beautiful women's coat. Edna caught sight of Rebecca standing naked in a line waiting to be "shaved". In her joint interview with Rebecca, Edna says: "*I found her, the beautiful hair she had, she was beautiful, she stood in line, everyone was already naked. I knew they would cut off her hair. But I didn't tell her ((starts to cry))*".

Edna cries and it comforts her somewhat to be able to tell us that she managed to slip her sister a piece of bread. These little things, these gestures of mutual help, offer the women some comfort now, as they did at the time. Rebecca had only been in Auschwitz-Birkenau three days, when she was deported to the Riga-Kaiserwald concentration camp<sup>41</sup>. This concentration camp in Latvia was one for both female and male inmates. It started up on 15 March 1943 and evacuation began on 6 August 1944. At first, Rebecca did hard forced labour in an armaments installation, suffering terribly from cold, hunger and loneliness as well, as she had no acquaintances. She says that she managed to create a sense of belonging for herself by cutting portions of bread into two for pairs of women who were unable to divide up the single piece allocated to them to their satisfaction. Like her sister, it comforts Rebecca that she was sometimes able to help others in the camp.

Rebecca was put in charge of her barrack. She explains the fact that she was chosen by a female SS guard to be "Senior Block Inmate" (*Blockälteste*) in charge of 150 prisoners through her knowledge of German<sup>42</sup>. This position

---

41 For details of this concentration camp, cf. Schwarz 1990, p. 185.

42 "Each barrack had its own Senior Block Inmate, nominated by the Senior Camp Inmate and confirmed by the camp headquarters. He was responsible to the Block Leader for everything that happened within his domain. ... the Senior Block Inmate picked as his assistants two or three Barrack Orderlies, who had to be confirmed by the Senior Camp Inmate.

meant that she no longer had to work outside the camp with the rest of the inmates, and that she was given extra food rations. This and many other privileges made her repeatedly stress in every meeting with us that: *"I had it best of all the sisters and brothers"*.

She says little of her own suffering. Rather, she talks primarily of what she actually did, of the positions she held in the various camps and of the situations where she was able to help other inmates. In contrast, she barely touches on the theme of the painful experiences she went through, of having to watch other inmates die, of her own fears or guilt feelings.

In August 1944, when the Soviet Army was advancing towards Riga-Kaiserwald, the camp was evacuated and the inmates transported by train to the Stutthof concentration camp near Danzig. After a week there, Rebecca and a number of others were selected for what she feared was the gas chamber, as she was ill at the time, but what turned out to be forced labour in Germany:

*"Later one day, again again there was a selection procedure, we stood in line, always five in a line, ... the minute they said "Appell" (roll call), if there weren't five of you, you got terrible beatings, so we were scared the minute they said "Appell", we'd already formed a group of five ... and then they selected us, I remember I had a fever then, and I cried terribly the whole time, and I thought this is the end for me but, I was sent to a labour camp"*.

Having arrived in the forced-labour camp in Germany, Rebecca was nominated as work team leader (*Arbeitsführerin*). Here, too, Rebecca says she owed this appointment to her knowledge of German. This position meant that Rebecca was responsible for organizing forced-labour teams and above all for supervising and reporting on the inmates' "fitness for work". Thus, here too, she was in the very difficult position of on the one hand being able to help fellow inmates, but on the other, because of the camp system, of being forced to cooperate with the SS and being involved in the "selection procedures". How does Rebecca speak about this herself? Rebecca recounts that this position allowed her to remain in the camp while the other inmates were forced to work in a distant aircraft factory. She says that she had to take care of sick inmates. She talks about being responsible for bringing sick inmates to the revier and writing a daily report for the camp commandant. The consequences that these reports could have emerge clearly in her story of two women who were murdered; one of them because she had been crippled and the other because she was pregnant. Rebecca could not get out of making these reports, a task imposed on her by the SS: *"Generally no one dared say anything. But, in such difficult cases, uh we had to tell, right."*

---

They were responsible for maintaining order and distributing (food) rations... they were often under considerable pressure from the SS". (Kogon 1950, p. 62)

In March or April 1945, Rebecca was selected by an SS guard for what turned out to be a transport to a forced-labour camp near Leipzig:

*"That's it so one day the "Aufseherin" (guard) came and selected 150, including me, and I thought this is the end, I cried a lot to tell the truth, and we were all afraid, and we were taken away at night, on a train to Leipzig, and we were taken to B."*

Rebecca says that when they arrived in Leipzig, the female SS officer who already knew Rebecca made her "Senior Camp Inmate" (*Lagerälteste*)<sup>43</sup>. She was allowed to choose two inmates to help her as her assistants:

*"I had to choose, and one, a nurse, she came from Ushgorod, there were three of us, me the Senior Camp Inmate and two more I had to help me. I got this black stripe, which said Lagerälteste, ... and I could go out to the Obersturmführer (commander) if I had to, because I had that, and a whistle"*

In this position Rebecca says that she had better food and improved living conditions, sharing a separate barrack with her two assistants. Some of the inmates she was in charge of worked in the woods. Rebecca says that it was important for the others to be seen to be working, even if they were doing nonsensical jobs. *"I decided that work had to be done in the yard, what's the yard, collecting stones and putting them on one side, the next day putting them back, but not working was impossible"*. She describes her position as dependent on the cooperation of the inmates: *"I had to go from room to room, from barrack to barrack, and beg them to come to work for one hour, 'cause otherwise- I would have been hanged, so out of mercy on me, and they liked me a lot because I wasn't uh- I was good just good, and, I did things you weren't allowed to do but when you're young you don't think, you just act"*.

It emerges how much Rebecca tries to see herself in this imposed role as the helper of her fellow inmates. To illustrate how much danger she herself was in and how the SS forced her to do what she did, she describes a situation where a mother was separated from her daughter in one of the selection procedures. Rebecca told them to change places with another couple so that they could stay together, and told all the inmates to keep it a secret: *"a hundred and fifty people knew, and I said, no one knew anything, they just did it on their own, or else they would have shot every tenth one of us"*. When the SS guard discovered that they had swapped places, Rebecca was ordered to take the young girl to the camp commandant. Rebecca describes her fear very vividly: *"we were afraid we'd die"*, and goes on to tell us that in the end, the pun-

---

43 "Among the prisoners there was an official and extensive system of self-government with the Senior Camp Inmate, appointed by the SS, as its head. ... The S. C. I. was the responsible representative of the prisoners before the SS. ... his job was crucial and dangerous, and to take it on required courage and character. The wrong man in this spot meant untold harm to the camp." (Kogon 1950, p. 60-61)

ishment turned out to be just cutting the young girl's hair off. The next day this forced-labour camp was liquidated. The inmates were sent on a death march towards Dresden. Masses of inmates marched in different directions, and thousands of corpses lay by the roadside. In the interview, Rebecca was only able to speak of her helplessness when she arrived at the point in her story where her group was finally liberated by the US army. She says that she just sat down and started to cry, and it was only later that she felt up to looking for food. She adds that everyone was too exhausted and starved to take revenge on the two female SS guards, who took off their uniforms and put on inmates' uniforms. Edna, the younger sister, still has painful memories of the ghetto in Munkacs. In tears, she told us of how, completely unexpectedly, a German soldier suddenly started beating her father. Rebecca, who was present at the interview, was amazed at this story, and said that she had never heard it before. Her response to Edna's crying was: *"Don't get so upset"*. Turning to the interviewers, she commented: *"After 50 years she's crying. That's the difference between us, I talked about it. So today it's easier for me, but she never wanted to talk about it"*.

Edna arrived at Auschwitz with her parents and two younger siblings. She describes how she was separated from them although her mother struggled to defy Mengele and stay with her children:

*"We got out with mother and father, suddenly, they took father and my brother away, and we kept walking with mother and they took us away from mother, we ran after her and started crying. I think it was Mengele, he said 'what are you running after your mother for like that, you're going to see her this evening, you're all going to meet up in the evening, you're going to work and everyone's going to meet up in the evening'. ... And mother cried terribly and shouted 'you should let them stay with me, I don't have anyone any more, leave me them, I want to go with them.' ... But he yanked us from her hands, and we cried all the way, and my sister was so weak, she was sick."*

After this violent separation from her mother, Edna devoted all her care and love to her sister Eva, who had a lung disease. In Auschwitz-Birkenau, she managed to get work in the Canada commando, where she was able to get some food and clothing to help her sick sister. In the interview, Edna's fear of her own annihilation was mixed with fear for the life of her sick sister. She said that a Senior Block Inmate had threatened her during roll call once: *"Look after her ((her sister)) or they'll burn her". And I took her"*. Edna started to cry at this point, and Rebecca, remembering her own position in the camp, said in reference to this Senior Block Inmate: *"She never came back"*.

Edna went on to describe how she used to look after her sister every day when she came back from the commando. They took turns trying to get each other to eat their own food rations and were mocked by the other inmates for their solidarity:

*"In the corner sat two other sisters from our hometown who said, 'what do you think, that you're still a Shapiro, you're still in A.?' They were always fighting among themselves: 'you took more than me'. And I cried, because I was thinking about my sister all the time, how hungry she is, and I eat and she's so sick".*

In January 1945, Edna and Eva were sent on a death march and then put on a transport in an open cattle wagon via Ravensbrück to a camp in Northern Germany. Edna was very worried that Eva would not survive the transport. When they arrived in the camp, Eva was so weak that Edna had to bring her to the revier. She was terribly worried about her sister and feared that she would be murdered: *"We were afraid they would take her to the crematorium, or kill her"*. Edna cried desperately as she told us of her sister's death:

*"The night she died my friend came to tell me that her last word had been my name. But before that I went in to her with potatoes and kissed her, and told her 'Eva, eat for me, because I can't stand it if you don't eat'. ... The next morning we were lined up, I saw them taking the dead, I knew she was among them, but they didn't let me go, to see where they were taken, fifteen days later I was liberated."*

Thus, Edna experienced the liberation just fifteen days later, full of grief at the death of her younger sister. Rebecca cut into the interview at this point, speaking of her more privileged situation in the camp:

*"I didn't have such a hard time of it as Israela ((her daughter's name)) uh, as Edna. Because I was alone. I didn't know, I was lucky 'cause my father was always looking after me. I felt it. And I always held a position. I don't know why they picked me."*

At this point a dialogue ensues in which we can sense a certain amount of bitterness on Edna's part.

- Rebecca: "I had an easier time of it, and I came out healthier. Those who worked got a bowl of soup."  
Edna: "We worked and didn't get one"  
Rebecca: "True, because you did a different kind of work. Our work-"  
Edna: "I know 'was essential"  
Rebecca: "Essential, no I'm saying, that you were- I was alone that's why I had an easier time of it. I was strong, too"  
Edna: "No. I was strong".

Rebecca tries to mitigate the competitiveness that emerges here by saying in a conciliatory tone: *"Actually a strong family. That's how we stayed nine. ... That comes from our parents."*



## After the liberation: starting a new life

After she was liberated, Ariela returned to Prague and met up with her brothers and sisters. In 1945, Ariela was 33 years old. In 1947, she married Yanush, a forced-labour camp survivor, who had lost his wife and little daughter in Auschwitz. They both agreed not to talk about the past. Their first son Shimi was born in 1948. One year later, they emigrated to Israel, where their daughter Ofra was born in 1950. Ariela and her husband ran a textiles store until Yanush died in 1984.

Ariela was plagued by fears that stemmed from the horrors she had experienced. She says that when her son was a baby, whenever he was sick she refused to give him to a doctor, afraid that she would lose him, too. Her son got married and had two young children of his own. Several years ago, his wife died suddenly of cancer, and now Ariela lives with his family. Even though she is eighty-four years old and very sick herself, Ariela feels obliged to take on the role of mother for her grandchildren. She also worries about her daughter Ofra<sup>44</sup> and her family a lot. Ofra lives with her husband and her six children in a Jewish settlement on the Golan Heights and knows she may one day have to leave this area. Ariela associates this with her life in Carpatho-Ukraine and argues that no Jewish government should drive out Jewish citizens.

Ofra Dgani is the first "Sabra" of this family, and she clearly distinguishes between her parents' life histories, which she presents under the theme of "Jewish life in the Diaspora", and her own life history as a pioneer who "has done everything with her own hands" on the Golan Heights. Unlike Rebecca's daughter Israela, Ofra speaks at length in the interview about the persecution in her parents' past. She addresses the theme of her father's and her mother's murdered children. This is the part of the persecution in their past that she finds the most threatening. She tries to heal the generation of murdered children by emphasizing the number of offspring in each branch of her family, and in her own life by having six children herself. It is striking that in her family sculpture, she places her murdered half-sister and half-brother very close to herself and uses the same colour codes that she uses for her own children to depict them.

The remembrance of these murdered children is something that is also very present in the life of the granddaughter Meirav Raz<sup>45</sup> (born in 1974). The first story that she tells in the interview is of how Mengele selected her grandmother to live, a story that her mother told her when she was four years old. Until recently, Meirav often thought about which of her siblings she

---

44 Ofra Dgani, Ariela's daughter, was interviewed in 1995 by Bettina Volter and Noga Gilad in English.

45 Meirav Raz, the granddaughter, was interviewed in 1995 by Bettina Volter and Noga Gilad in English.

would have rescued in such a selection procedure. She is haunted by nightmares where she is hiding in a synagogue and the Nazis are looking for her. As a pregnant, married woman, she stresses that it is very important for her that her grandmother lives to see her great-grandchild.

Having children is an important theme in Edna's family, too. She married a man who survived as a partisan with his father. Like her sister Ariela, Edna hardly spoke with her husband about the persecution. After immigrating to Israel in 1950, she studied social work at university. She went on to work with underprivileged children, to compensate for the fact that she could not have any children herself. When in 1954 she did become pregnant against all odds, she carried the child to full term against the advice of her doctor. Today her son is married and has three sons of his own. She says herself that she still has a symbiotic relationship with her son: *"My daughter-in-law says, if he could go inside your womb again, he would"*.

After the liberation, Rebecca returned to Carpatho-Ukraine first and met two of her brothers there. Like her sisters, she also went back to Bohemia, initially to Prague. There she met Herman Sneider, who came from Munkacs and had survived Auschwitz. At first, the couple lived in a health resort in Bohemia, marrying in 1947. Their eldest daughter Israela was born here in 1948. The birth of her daughter triggered Rebecca's fears. She became afraid that the German soldiers would come back and take her child. It was only when she emigrated to Israel in 1950 that she began to feel safer:

*"I felt released when I arrived in Israel, because there ((in Bohemia)) I always thought that, I dreamt that the Germans would come back, because we were even living in apartments from Germans, you see? So the recurring dream was that one knocks on the door, that they come back, so I always hid Israela, I dreamt how I protected her, that I lay over her so that they wouldn't shoot her, just me."*

Her son Yochanan was born in 1952.

She speaks about her husband Herman in much same way that she talks about her sister, saying that unlike herself, he hardly ever spoke about the past until a few years ago. She says that this is one of the reasons why he suffered far more than she did from the persecution right until his death in 1993: *"He never talked about it either, but, once he started to talk about it later, but he didn't- he wasn't liberated until his death"*.

In contrast to Herman, Rebecca held talks in schools about the persecution and met with survivors to talk about the Shoah. She argues that her husband had no wish to meet with survivors: *"He didn't want to hear anything about the camp any more, he went through an awful lot, a thousand times more than I did"*.

## *Learn, Observe and Study: The Sneider family*

Noga Gilad, Yael Moore and Gabriele Rosenthal

The grandfather Herman Sneider: Responsible for looking after the twins and dwarves in Auschwitz

Herman<sup>46</sup> was born a twin in 1915 and lived with his family in Munkacs in Carpatho-Ukraine. Besides his twin sister, he had two younger brothers. When he was older, Herman went to business school and studied accounting. His father, who was in the same profession, gave his children the message that education was the most important thing in life. In the interview, Herman repeatedly referred to his father's message, which he passed on to his own children, too: *"You have to learn. You can eat dry bread and onions. But fill your head with whatever you can because no one can take that away from you. That was his motto: learn, learn, just learn"*.

Herman wanted to get ahead, too. In 1937, at the age of twenty-two, he enlisted in the Czech army and went to an officers' academy. He identified with the new state of Czechoslovakia, founded after World War I; in his view, Carpatho-Ukraine was occupied by the Hungarians and liberated by the Czechs. This sense of belonging culturally to the Czech nation is something he shares with his wife Rebecca.

When Carpatho-Ukraine was annexed by Hungary, Herman served briefly as a soldier in the Hungarian army. Then he was arrested and made his way from one forced-labour camp to another. In 1944, he was deported to Auschwitz-Birkenau with his parents, his sister, her son and her husband. His younger brothers survived in forced-labour camps. He saw his parents for the last time on the ramp at Auschwitz, where he and his sister Eva were selected to "live", because the camp physician Josef Mengele was interested in them for his experiments. Mengele deceived Eva into thinking that her seven-year-old son had been taken to a children's barrack. She herself was taken to the women's camp. It was only some time later that Eva realized her son had been murdered in the gas chamber right after they had arrived. Her husband did not survive the camp either. Herman was put in what was known as the "twins' block", which was about one hundred meters from the crematorium, near where the Sinti and Roma were housed in what was known as the family camp for gypsies.

Before we go into Herman's experiences in Auschwitz-Birkenau in more detail, a few remarks about the situation of the twins, who were designated for Mengele's experiments, are perhaps called for. Josef Mengele, who became camp physician in Auschwitz-Birkenau in May 1943, had an experimental

---

46 Herman Sneider was interviewed by Gabriele Rosenthal in German in 1991.

laboratory in the camp where he carried out pseudo-medical experiments on twins and dwarves. He tortured his victims in the most cruel way imaginable. He gave them injections to try to change the colour of their eyes or their hair, had twins sewn together, sterilized them, removed their genitals, inner organs and limbs, infected them with sicknesses by giving them painful intravenous injections of typhus and tuberculosis bacteria and tried to do sex change operations on them (cf. Lagnado/Dekel 1991). After the experiments, he murdered his victims by injecting phenol into their hearts, then conducted pathological analyses of their organs and sent them to the Kaiser-Wilhelm Institute in Berlin (cf. Encyclopedia 1995, p. 942). Of an estimated three thousand twins, only about a hundred survived. Whenever transports arrived in Auschwitz-Birkenau, the guards "searched" for twins. For these children, being selected for Mengele's experiments meant escaping death, if only temporarily. Some of the child-survivors still have an ambivalent attachment to this doctor, some still call him "Uncle Mengele", as they did then, and think of him as the man who treated them in a "friendly" way, gave them sweets and cuddled them, to whom they believe they owe their lives<sup>47</sup>. Herman Sneidler, who was 27 when he arrived in Auschwitz-Birkenau, was spared having to undergo this doctor's experiments. Mengele gave him the task of taking care of the children and dwarves. Herman has an explanation that seems plausible to him for why Mengele chose him for this position:

*"And the first time we saw Mengele, he went past, came back, asked me 'were you a soldier'. Why? I was standing in front of him like a soldier. Yes, sir! (Mr. Sneidler imitates a soldierly posture). He says: 'You're responsible for the children'. He made me the twinfather. 'And if anything happens, you're a goner'."*

And this is how Herman Sneidler came to be in the position of having to look after the children and the dwarves. For him, the pleasant parts of his job involved keeping the children entertained and being able to give them some schooling in makeshift lessons. Herman saw himself as the twins' father, not as their "Kapo". But the Nazi doctor Mengele also made Herman his assistant in his experiments. Herman had to "prepare" the children for the experiments: he had to bath and wash them before they were taken into Mengele's laboratory. When they came out afterwards, he had to take care of them, calm them down and report back to Mengele on how the "experiments" were progressing.

How does Herman deal with this past today? What does he himself communicate about his forced collaboration with camp physician Mengele? In the interview, he repeatedly spoke about having "three things" to say about it. He

---

<sup>47</sup> For more on interviews with twin-survivors, cf. Lagnado/Dekel (1991). In addition to the interview with Herman Sneidler, Gabriele Rosenthal conducted other interviews with twins who survived Mengele's experiments.

is referring here to three situations in which he was able to help the children. He told us the story of how one day an officer was given the order to *"take the children to the crematorium at once"*. Herman reacted immediately: *"I run courage now, it was already dark, run to the gate and say 'I want to talk to Mengele'. Mengele was more than God. Yeah I talk to Mengele, tell him about it and he gives an order 'all back'"*.

After this story, Herman went on to relate the "second thing". He told us of a transport where there were two children of roughly the same age who were dressed alike. He faked their birth dates, making twins of them, and saved them from being murdered in the gas chamber this way. Evaluating this deed, he said: *"That was the biggest lie that anyone told Mengele. If Mengele had noticed it, instantly I get a bullet through the head. That is the second thing and the third thing is that I brought the children home"*.

After the liberation, the surviving children held him to his promise that he would bring them home. He set off with 36 children to bring them back to their "homelands". For Herman, this story concluded his account of Auschwitz. He added: *"Yes these three things, where I say that is extraordinary, everything else-."* He reduces "everything else" to the statement: *"Everyone knows what Auschwitz was."*

Rebecca, who was present in the second half of the interview with Herman, took on a very similar role here to the one she assumed during the joint interview with her sisters. She tried to protect her husband, but in the process blocked him from talking about the persecution in his past. She kept explaining that her husband had suffered far more than she had, but talked about it far less. She said that this was why he had suffered more after the liberation from the after-effects of the persecution than she had. She gave the interviewer the message that her husband had made everything out to be somewhat simpler than it actually was out of consideration for his listener:

*"He stayed. He was in constant fear. More than anything else he was afraid. He was afraid, he's sitting here calmly now, but he isn't calm, don't you believe it. And in the early years he was afraid, that he would go crazy. It was never as simple as he told it. He told it very nicely, but it wasn't so nice. He wants to make it nice, because he's a good man. He wants to help you. My husband is a hero. He brought the 36 children home, he saved them."*

Here, the interviewer asked Rebecca about a loaded aspect of her husband's past, with a question about what relationship Herman had to Mengele. Rebecca replied: *"He doesn't feel any hate. That's very interesting. Sometimes people have said to him, 'You talk about Mengele as if he were an angel, the white angel'. Very interesting."*

## The daughter Israela: The many hidden faces of the past

How does Herman and Rebecca's daughter, Israela<sup>48</sup>, who was born in 1947, live with her parents' past? How does she speak about the fact that her father was responsible for the twins and dwarves in Auschwitz and her mother survived as an inmate-functionary?

But first, let us look at Israela's biography.

### The delegations: professional success and victory over the Nazis

Israela, who has been very successful in her professional life, belongs to the generation of "The New Life" (cf. Gilad 1995), who were brought up by their parents to compensate directly for their horrible past, marked by loss and death. They were required to use their own lives to heal their parents' painful memories. As "Sabre", they were supposed to grow up to be strong Israelis. The fact that her mother interpreted every step of her life as a victory over the Nazis made Israela orient herself even more on this image: *"I have to emphasize it, my mother specially used every event that took place in my life as a victory over the Germans"*.

By focusing on victory over the Nazis, her mother blocked out her grief at the loss of those, who were murdered in the Shoah, and at the pain she had suffered herself:

*"Now concerning the Holocaust, there was not a day my mother didn't tell us. Every detail but from the perspective of how she had won. How we survived. How we beat them. Even though we knew that they had lost I mean lost a brother or lost children"*.

In Israela's biography, her mother's delegation to beat the Nazis is linked to her father's delegation to be successful in her career. Professional success is of crucial importance to her. Israel presents herself with the biographical global evaluation: *"I always wanted to study"*. Even at school, she was able to make her parents happy by getting good marks: *"Any good mark, they showed it to all the uncles and aunts, my father took it to work in his bag, meaning that there was a feeling that- being a good girl is very important to the parents"*. Her father especially spurred his daughter on to study: *"My father wouldn't let me sit outside after school with the girls. ... `What are you sitting doing nothing, it's forbidden to do nothing"*.

Israela's orientation on her father becomes apparent in the further course of her life: in the army and in her choice of partner. After she was drafted into the army, the eighteen-year-old opted for a career as an officer. After her military service, Israela went on to study psychology. In 1967, at the age of

---

48 Israela was interviewed in 1994 by Noga Gilad in Hebrew.

twenty, she married Amnon Lichtenbaum. Amnon comes from a family who emigrated to Israel in the twenties because they were socialists and who live on a kibbutz. Amnon is a trained pilot and professional soldier. The couple moved from one Israeli air force base to another. Their first son, Ethan, was born in 1971 and their second, Ehud, in 1975. In 1980, the couple went to the US with their sons to do post-graduate degrees. Their third son Yuval was born there in 1983. Israela and Amnon were successfully awarded their doctorates and the family returned to Israel. While Amnon went back to work for the army, Israela embarked on another degree, this time in business administration.

This change of field was also oriented on her father's values. Israela rejected what she saw as psychology's lack of objectivity, opting for a professional field that was more oriented on "hard facts": *"All of a sudden I realized that my views are as conservative as my father's, who knows what's bad or good, that law would do, or medicine, because it's hard facts, such black and white answers"*.

Israela has since set up her own business and is very successful at it.

### Joy after the Holocaust

Even at the beginning of the interview, when Israela was telling us her early childhood experiences, it became obvious that she presents herself in the thematic field of the Holocaust:

*"There are a few stories about me, that I got lost and I was saved and I was undernourished. I remember myself at the age of three or four, struggling to get into the kindergarten 'cause I was younger than all the rest, now perhaps it's worth noting, that the whole neighbourhood were Holocaust survivors."*

Struggling, surviving undernourishment, getting lost and being found are all things that are embedded in the field of "Holocaust survivors". Thus Israela presents the early part of her life within the thematic field of surviving and struggling against the background of the Holocaust. This presentation continued throughout the interview. Israela did not talk about her parents' suffering during the Holocaust. Instead, when she spoke about her family, Israela emphasized the themes of harmony, the aesthetics of food, and victory over the Germans. She idealizes her childhood, continually emphasizing the *"positive atmosphere we grew in"*, the happiness and joy that her mother always created. She stressed the way her mother talked about *"how we beat the Germans"*. It is painful for Israela to look at the horrors of the past. However, she does reflect on the emotional denial in the way she deals with the Holocaust.

When she talked about her husband's involvement in the war of attrition<sup>49</sup> against Egypt, she argued:

*"My way of dealing ((with the war)) was a way that was based very much on the way my parents dealt with the Holocaust: a kind of an absolute denial, no relation whatsoever to reality...not being aware of the dangers, I kept studying, like nothing's happening. It's related to the way my parents denied painful things and just kept going"*

Since Israela acknowledges this structure and nonetheless remains trapped in a structure of denial throughout almost the entire text, it is worth asking - what is it that is too painful for her to look at?

The horrors of the Holocaust "sneak" into her text. She is quick to silence them by stressing the joyful atmosphere at home with her parents:

*"Even though we knew that they ((members of the family)) lost I mean that they lost a brother or a a lost children, my mother's sister lost her girl, the joy of life, I know from friends of mine too, that at our house it was always so happy and there were lots of aunts and uncles"*

When Israela relates to the past, she generalizes experiences, particularly her mother's; she relates to the theme of the "general suffering of survivors" and presents her mother as a "typical survivor". Whereas when speaking of her father in this context, she indicates that he survived "horror", in connection with her mother, she repeatedly speaks of hunger and of cold:

*"He ((her father)) went through horrors, we didn't know, better not ask, and mother all day long, Shoah, when a piece of bread fell we had to pick it up, kiss it, remember the hunger in the Shoah and finish everything up- food and clothes were special topics".*

By using this generalization, she successfully circumvents the realm of her mother's personal experiences: those of being in a privileged position, being in charge of others and having better conditions - including more food - than the other concentration camp inmates. Instead of drawing nearer to this part of her family past, Israela concentrated on the theme of food; she talked about how beautifully food was always decorated and served at home and about the importance of food in the family. We interpret this as a kind of family myth that covers up the theme of having had privileges in the camp. Israela physically expresses her own thoughts about the family's excessive preoccupation with food through a symptom: *"I was not a good eater...I didn't want to eat, I was a very thin child, so thin that they told her ((her mother)) that I was undernourished"*.

---

49 After the Six Day War (1967), President Gamel Abdel Nasser of Egypt initiated a war of attrition along the Suez Canal, which lasted around three years.



Further on, Israela's unconscious thoughts about her parents' experiences in the Shoah emerge, especially about her mother's position in the camp:

*"My mother used to say to me 'you can do anything' and then tell me what she did ((our emphasis)) in the concentration camp. Millions of times I heard the stories about the camp. And my father used to say every once in a while: 'a lousy world'- half schizophrenic, on the one hand I can do anything and on the other hand the world is lousy".*

She was given different messages by her father and her mother. We may well ask what is behind this reference to what her mother did? She tells her daughter she can do anything; what was she able to do in the camp in her various positions of "Senior Block Inmate" (*Blockälteste*), "Work Team Leader" (*Arbeitsführerin*) and "Senior Camp Inmate" (*Lagerälteste*)? Israela does not talk about this. Likewise, she does not speak about her father's experiences. But when asked by the interviewer to say something about her father's experiences in Birkenau, she replied:

*"I have stories about twins he dealt with. We only knew that it was very difficult for him and that you shouldn't ask him, or that you should finish up all your food. There was a picture of a pair of twins who thanked him for bringing them home. There was a permission slip at home that Mengele gave him so he could get 20 cigarettes a day. I didn't want to know more, he didn't want to talk and I didn't want to ask, I have to ask you what your aim is?"*

In Auschwitz, cigarettes were considered a unit of payment; a piece of bread could be bought on the "*Lagermarkt*" (camp market) for five to ten, and sometimes even just one, cigarette (Pawelczynska, 1979, p. 104). Thus, the mention of a goods receipt for twenty cigarettes a day means that the theme of her father's privileges is co-present here. Her father's history not only brings up questions of collaboration but also traumatic themes like experiments on children, torture and Herman's relationship to Mengele. It is too painful for Israela to deal with these horrific themes. To change the threatening subject of the experiments, Israela asks the interviewer about the intention of her research ("*what your aim is*"), which brings her closer to her own academic interests. In another sequence in the interview, she presents happy memories of her father: "*I remember him coming back home I was so happy... feelings of happiness that father's come home ...I didn't dare in my life be angry at him or think badly of him.*"

Thinking "badly" is censored: several times in the interview, this sets off a mechanism whereby Israela changes the subject from talking about her parents' past to relating to the present of the actual interview: "*I was born to them after, after they are released from the army, ah army I say. Do you have children of your own? I was born to them two years after they were released from the camps.*"

Locating her parents in the "army" may indicate Israela's fantasy that her parents were different from other survivors. It is also reminiscent of Herman's being "selected", or chosen, by Mengele for his "Kapo" position because Mengele realized that he was a soldier. This position meant that he was in charge of children, and it is at this point that Israela asks the interviewer whether she has any children. Israela does not allow herself to question her parents' past, or to express anger towards her father. But how do her aggressions come out? She has to cover them up with harmony. This emerges very clearly in the following sequence where she speaks in the context of the Shoah of her fantasies of murdering her brother: *"When a piece of bread fell we had to pick it up and kiss it, because of the Holocaust. I was never given food that wasn't decorated, one more thing, when my brother was born I was five years old, I remember I was so excited, I remember I said I'll throw him down the toilet...we ((she and her brother)) always got on well together."*

It must be mentioned here that fantasies like Israela's of throwing the baby down the toilet are quite common among five-year-olds; what interests us here is the sequence of associations: in her chain of association, Israela connects her death wishes towards the baby with her mother's Holocaust experiences. Israela's aggression at being forced "to kiss the bread that had fallen on the floor" and subjected to stories about the Holocaust all day is associated with the theme of "killing babies". We could interpret this as her redirecting this aggression at her brother. But between the lines in this sequence is also the hidden theme of children and babies who were murdered in the Holocaust.

Decorated food may be a symbol for the Holocaust, which was given to Israela "decorated": "decorated" with the victory over the Germans, covering other painful themes like suffering, death, torture and forced collaboration.

The grandson Ethan: The observer

Ethan<sup>50</sup>, Israela and Amnon's first son, was born in 1971. At the time of the interview, the twenty-three-year-old was serving in an elite unit of the Israeli army, having enlisted for five years. When he has finished his military service, Ethan plans to study so as to be able to have *"a real career"*. His biographical self-presentation focuses noticeably on the theme of "science". He presents himself as someone who has been very interested in mathematics and physics since childhood. Like his mother, he is oriented on "hard facts" and tried to give the interviewer exact years in the outline of his biography; in contrast, he does not express his feelings much. Thus, Ethan corresponds to the image of the young Israeli: "The young Israeli often demonstrates emotional restraint, compulsive avoidance of any pathos ... in a discussion where it

---

50 Ethan was interviewed by Noga Gilad in 1994 in Hebrew.

is obligatory to express emotions, young Israelis cling devotedly to a crude way of articulating them..." (Elon 1981, p. 239).

Let us examine Ethan's individual biography. The first years of his childhood were marked by constant transitions as his father's career meant that the family moved from one air base to another: *"I grew up more or less as the son of a pilot, running around on air force bases. ... Nobody brought me up to be a pilot and I didn't hear too many hero stories ... It was something father did, father's job"*.

He uses the image of a kibbutz to normalize having grown up in this environment: "It was like a kibbutz, just that the fathers of my friends were pilots too, and our swing was made from the wing of a Syrian plane".

Ethan uses this repair strategy to completely eradicate any trace of the Israeli wars, including the Yom Kippur War of 1973, and of his father's experiences in combat.

This life changed when Ethan was nine and he and his family moved to the United States. For Ethan, this next phase of his life is linked to spending time in the research lab where his father was experimenting on animals as part of his PhD. It was during this time that Ethan found out about the persecution that his grandfather had experienced in Auschwitz. Herman had come to the United States for a gathering of the "Mengele twins" and Ethan read all of the reports that were published about it in the newspapers. Ethan's grandfather became a hero for the eleven-year-old boy. He saw him as the man who had saved the twins and brought them home after the liberation.

The things that Ethan observed in the lab are thematically linked for him to Herman's past in Auschwitz: *"Both of my parents were at the Academy...my father was in the laboratory a little bit...I used to sit with him during the experiments...monkeys and cats. It'll be interesting for you the story about grandfather...the twin who came and met him..."*

During these years, Ethan developed his skills as a "child researcher", both in a special mathematics program for children and by conducting his own "research projects" at school. He did biophysics research, like his father was doing in the experiments that he used to watch: *"I would sometimes sit with him during the experiments. ... He would sit in the laboratory and record results, of monkeys and cats, ... And I would pretend to understand"*.

Ethan gave a vivid description of the room where the experiments were conducted, of the special electronic equipment and the way the animals looked when they were hooked up to the electrodes:

*"It was always in some laboratory, always in the centre was some cage, with a cat, or a monkey that had an electrode in its brain, their head was open ... They were anesthetized but their eyes were open ... The whole room was darkened... The truth is that it was quite boring"*.

At this point, he hesitated, made a lengthy pause and wondered why he had stayed in the lab anyway. He concluded that the reason was:

*"Either because mom would send me, so that dad isn't alone, or because I felt I was a hero if I sit with dad the whole night long. And in the end I decided that I was having fun there. I think it was especially about being with father".*

Ethan felt like a hero, too. For him, the experiments on animals were linked to the ideal of the heroic observer. We may well ask whether he is unconsciously identifying with his grandfather here. Ethan's description of the chimpanzees with open craniums also brings this association to mind: one of the American newspaper articles on the twins' gathering contains a report in connection with Herman Sneider on a twin whose cranium was opened by Mengele, who survived this and now lives in Israel in the neighbourhood where Ethan's grandfather lived.

Back in Israel, Ethan was present at an interview that a British historian conducted with his grandfather and even helped with the interpreting. He was amazed by a list he saw of all the twins who had left Auschwitz with his grandfather: *"Columns of all the twins, numbered, where from, a name, where to return them to, who their twin was, what happened to their parents"*.

Like his grandfather, Ethan focused on the part of his history linked with helping and saving the children:

*"Eventually that story became very big, with a lot of details, ... I know them all. The gist is that he was an 'Auschwitz Zwilling' ((twin)), ... He fell into the hands of Mengele, and since he was practically the oldest twin, he was appointed by Mengele as being responsible for all the rest of the twins. And he more or less treated them like, a father, everything they went through, and like a teacher he did math and history lessons and all those things with them, all of it was in Auschwitz, from there with hundreds of stories about all kinds of opportunities he used to save twins".*

Ethan also told us the three stories that we had heard from his grandfather; the "three things" relating to instances where Herman was able to help twins.

But Ethan also has questions about his grandfather's past. For instance, he is preoccupied with the question of why Mengele chose him for the position of "twinfather". His explanation is different than the one Herman gave about it being related to his soldierliness. Ethan explained: *"Actually grandfather was the eldest twin...I guess that his value for experiments was low because he had a twin sister, these two factors may have led to him being responsible for the twins, his responsibility was to take care of them, see that they are organized, collected, that everything's alright with them, that they come on time and go on time, that was more or less his role..."*

On a latent level, Ethan wonders about the "definition of the position" Herman had in the camp, and what it involved besides what Herman has explicitly told him about being "*the father and teacher of the twins*". But when it comes to the other procedures involved (experiments and torture), Ethan is only able to give a brief argumentation about his grandfather keeping the twins in order and making sure they were on time. Ethan has difficulties relating to the experiments that were conducted on the twins. When he relates to "*that they come on time and go on time*", he does not go into detail about what took place between these different comings and goings: he omits the time during which the experiments - that were really more than torture - took place. In contrast to his mother, however, Ethan comes much closer to his grandfather's experiences in Auschwitz and the threatening questions that they raise. But unlike her, he did not speak in the interview about the persecution that his grandmother Rebecca suffered. The extent of his denial of any knowledge of her past becomes very clear in the family interview.

*The family dialogue: A family who do not ask*

Yael Moore

After several cancelled appointments, a family interview took place in spring of 1995 in Israela's home. The interviewers were Gabriele Rosenthal and Noga Gilad, a German and an Israeli. For the first half of the interview, only Israela and Rebecca were present. Ethan joined in about three-quarters of the way through and towards the end of the interview Amnon, Israela's husband, and Ehud, one of the other grandsons, joined in as well.

Writing a summary of the Sneider's family interview was a difficult task. Words were debated for hours and then discarded. A commitment to the written word seemed dangerous and became an obstacle: especially the use of words like "experiment" or "science" in relation to Mengele's crimes. It seemed as though certain words forced the user to enter into the realm of the Nazi linguistic system. Thus, the act of writing (of self-expression) became, in a sense, an act of cooperating with and assimilating the "rule of language" (Arendt 1964). Guarding the language we used made it necessary to have two systems of words on hand simultaneously: one deriving from the "clean" bureaucracy of Nazi ideology and the other exposing the crimes behind these euphemisms. Thus, "experiments" for example, means nothing more in this context than brutal torture. Or choosing between the words "witness" "observe" or "participate": each one would suggest a different relationship between Herman and Rebecca and the Nazi persecutors. The question is why this dilemma took on these dimensions in the case of the Sneidlers. Both of the Sneider grandparents were forced to take on a position in the bureaucracy

of a criminal system. They were the forced mediators between persecutors and victims. The difficulties inherent in writing about this case mirror the questions and problems that the Sneiderls have relating to this past.

Herman's experiences of the Holocaust are at the centre of the family dialogue. On both a manifest and latent level, the other family members circumvent Herman's past. The family dialogue is loaded with attempts to prevent anyone from touching the core of Herman's past, indeed with attempts to silence this core - his relationship with Mengele and the experiments done on the twins. These scenes are at the centre of the narratives of all three generations and are hidden in the family discourse.

Herman died a year before the family interview, an occurrence that increased his centrality in the family dialogue. Talking about him allowed processes of mourning and remembrance to take place. At the same time, Rebecca's experiences are actively dismissed by Israela and Ethan. This was probably also the case when Herman was alive: his special position in the Holocaust was a bright light in the family. The fact that the family focus on the persecution in the grandfather's past allows the grandmother's past to remain in the sidelines of the family dialogue. The other family members pay little attention to her past, allowing questions about her positions in the camp system to be avoided.

The interview was conducted in four languages: Hebrew, German, English and Hungarian. Hungarian was used as Israela and Rebecca's private language and was used to form a private "pocket" of communication between the two, where no one could intervene or ask questions. Even though Rebecca, the grandmother, does not understand English very well, this was the language of open dialogue: when the family wanted almost everyone to understand and be able to communicate, this became the dominant language. Hebrew was the language used for communicating about things outside of the theme of the Shoah: everyday activities, like making coffee, ordering pizza, asking for a certain book, etc. No one talked about the Holocaust in Hebrew; it constituted the language of the "new" reality of the present. And German was also spoken: the language Rebecca used to communicate her Shoah experiences to the German interviewer alone. This was the language of the Shoah, of hatred of the perpetrators: the "skill" that helped her being chosen for a privileged position and also the language of Rebecca's longing for her mother, who loved German language and culture. These four languages are an analogy of the pendulum of the family dialogue.

### The Myth: Humaneness and Modesty

The grandfather Herman's persecution serves the creation of a family myth. This myth consists of three main features: Herman's saving children in the camp, his modesty and his humaneness. The grandmother Rebecca told us:

*"He didn't want to speak. He was very modest".* Israella confirmed this by saying: *"At the funeral of my father and during the mourning period everyone...concentrated on his Holocaust experience and mainly on his very admirable behaviour. We admire his unusual capability to remain human, humaneness."* The grandson Ethan also confirms this image: *"It was some sort of decency, plain human decency in all respects had it been in the Holocaust or not. A person without- it has nothing to do with himself, everything to do with everyone else..."*

The second and third generation emphasize the aspect of humaneness and dignity. These abstract, generalized concepts are a means of silencing Herman's personal story, the specific details: how he suffered in his capacity of witness of cruel experiments, his relationship with the twins and especially his relationship with Mengele. This myth conceals Herman's traumatic experiences. The second and third generations find these experiences so threatening that they cling very tightly to the myth. It serves to avoid painful questions about the children, whom Herman could not save, and the situations where his humaneness was discarded; it serves to protect his descendants from the terrible questions that Herman's personal story raises. Modesty is a repair strategy for silence. The modest do not speak of their good deeds. Another family secret hidden behind the myth of modesty is Herman's curiosity. There are hints that this curiosity led to Herman seeing horrific things. Rebecca gave this account: *"He told me something that he was (3) actually he was where the revier ((infirmary)) was. He knew everything, because he was very curious, too. Told me what they did. He saw too, how they laid the bodies in the bathroom, with the tub full of water. It all, the flesh came off the bones. And saw how two twins were sewn together. He saw a an awful lot but he didn't tell everything".*

In this sequence, Rebecca has penetrated the thin layer of myth to what lies beneath it. On a latent level, Israella protested against her doing so and changed the subject. She turned to her mother and said: *"Today you asked me if I've got bread with me, right?"* Israel finds what Herman witnessed - twins being sewn together, the bathtub, children being tortured - extremely threatening. Here, this member of the second generation tries to deflect the dialogue to her own experiences of ways in which the Shoah had an impact on her life. During the entire interview, it is the grandmother who "drops" hints here and there about the past. Rebecca is a survivor who wants to talk about her experiences. Perhaps her own experiences during the Holocaust allow her to see Herman's experiences from a different perspective and have a different sense of proportion about them than members of the second and third generations. But whatever the case, whether Rebecca drops hints or not, the second and third generation make a concerted effort to block all attempts to ask questions and all curiosity about the past.

## Blocked questions

The second and third generation avoid asking questions about Herman and Rebecca's past. In the following sequence, Israela indicates how greatly she feared asking Herman questions about his experiences in Auschwitz: *"When he was alive I wouldn't have dared ask him tough questions and he wouldn't even have been capable of answering because he wouldn't have wanted to deny anything and especially not to hurt me."* We may conclude from Israela's argumentation that "tough questions" are doomed to denial. Denial, or silence, are repair strategies used to avoid the pain of the past, to cover up Herman's horrific experiences.

Where Herman's history is concerned, a knowledge of actual facts is perceived by the third generation as more frightening than fantasies. Ethan, the grandson, told us: *"I don't think I had anything to ask him, even during the last few years when he was alive I didn't ask him anything, I guess I didn't feel the need, it is not important for me to know the actual facts."*

Instead of asking questions about the experiences in the first generation's past, the second and third generations use two repair strategies that allow them to relate to the past without feeling threatened: using collective experiences of the persecution to conceal individual ones and using abstract, general ideas to conceal the details. To make her parents' past seem less threatening to her, Israela avoids her parents' individual experiences. Her son, Ethan, uses another repair strategy. He avoids all of the details of his grandparents' past. Instead, he prefers to relate to an abstract global impression of his grandfather and avoids the specific reality of the past by replacing it with symbolism.

Let us look more closely at these two strategies. Israela relates to the collective story of the Shoah with its scenes of mass murder, hunger and cold, among others. Hunger and cold both conceal a family secret kept by the first generation - that they were in a position where they had more food and clothes than the others. Israela reflects back on the cold she felt, when she was skiing once, and imagines the cold people suffered in the Holocaust, or imagines a crowd in a public place in Israel in connection with the Holocaust to "get" a sense of what mass murder means:

*"When I see big groups I always think that the Nazis killed this entire group. Or the numbers are inconceivable, so, I think of Tel-Aviv, how can a whole city be erased, hundred, half a million. The Nazis in two months, systematically killed four hundred thousand, well, you read it, well you=don't=understand it you try to translate it into reality like that, four hundred thousand killed."*

This sequence was followed by an incredible unrest in the room: suddenly Israel was talking on the telephone, the younger son was looking for a book, everyone was talking all at once. When a certain level of concentration de-



scended on the room again, the German interviewer confronted Israela with a possible connection between this fantasy and her father's past: "*While I was listening to you (1) I kept thinking of your father who lived next to the gas chambers in Birkenau*".

Israela, who had said earlier that she was informed about the history of the death camp, replied that she had not been aware of the location of her father's barrack. Rebecca responded to this by saying to her in Hungarian: "*He saw everything*". Israela translated this into English and commented on it by remarking that her father had never told her this. Rebecca went on to say, this time in German, that Herman had seen the *Sonderkommando* (special commando)<sup>51</sup> at work and had watched them "liquidate" the family camp for gypsies and lead its inmates into the gas chambers<sup>52</sup>. Again Israela asserted that she had never heard about this from her father. Rebecca again asked her in Hungarian in an irritated voice whether she was saying that she knew nothing about the gypsies. Here again the daughter referred to her father, thus distracting from herself: "*He never got free from it*". It becomes apparent that Rebecca is willing to talk about Herman's traumatic past in Auschwitz-Birkenau. She also wants to talk about her own traumatization. Encouraged by the interviewer, she speaks of how much she is haunted by fantasies about the death of her parents in the gas chamber: "*...I always see my mother that she's there ((in the gas chambers)) and she can't get any air and father ALWAYS, MORE AND MORE*" (*Rebecca shouts very loudly*)).

When Israela hears this, she cannot bear to listen to her mother's terrible pain and turns to her son, saying: "*Ehud put the phone down*", then she turns to the German interviewer and says: "*I'll give you an example my mother told me.*" Her mother intervenes, though, wanting to repeat what she has just said and begins to say it to Israela in Hebrew. But Israela interrupts her and talks about herself. This interaction is typical of the dialogue structure between mother and daughter throughout the interview: Israela cannot listen to her mother. Whenever Rebecca spoke, Israela walked around, when Rebecca mentioned her mother's death, Israela ordered a pizza, when Rebecca talked about her family, Israela spoke to someone on the phone. Thus Israela allows her mother to speak but blocks any chance of hearing what she says. It appeared in the interview that whenever Israela was busy doing something else (talking on the phone, for example), Rebecca felt free to talk about her past. Israela competes with Rebecca for the floor. On the other hand, it would seem that from her own perspective, Israela's biography is in the shadow of the traumatic and problematic biographies of her parents. In other ways, too, some members of the second generation struggle for the right to have an individual biography and some, consciously and unconsciously, accept the domi-

---

51 The gangs of inmates in Birkenau who had to work in the gas chambers and crematoria.

52 On 2 August 1944, the family camp for gypsies, located near the twins' barrack, was closed off and that night nearly all of the inmates were murdered in the gas chambers.

nance of the first generation's life history over their own (Moore 1994). But both mother and daughter suffer from the impact of the past, and both want recognition and empathy for their suffering.

The dynamics of this family dialogue enforce the structure of blocked questions. Questions open the door to the act of listening to someone else. As mentioned earlier, the structure of blocking the emergence of questions is something found in the third generation, too. Let us now turn to Ethan, the grandson, and examine his repair strategy of blocking questions as a means of diminishing the threat of the past by relating to it through global and abstract impressions. Ethan was not yet in the room when his grandmother was talking about what his grandfather had experienced in Auschwitz and about her own traumatic fantasies about her parents. When he was present at the interview, he focused on Herman's past, too. Ethan is preoccupied with the global impression of Herman in his memory (modesty) and refuses to hear any details of Herman's experiences. Arguing about Herman, Ethan claimed:

*"It ((the Shoah)) isn't really about facts...it's not really important whether the exact days were X and Y or the number of children were Z or G. Whether he actually did something- ((author's emphasis)) It's not really about the fact, but more about the symbolics of the whole thing...I have a sort of generalized view `of my grandfather' in connection to and without any connection to the Holocaust...a view, an observer...from the side...not something that was in any way built up through a conversation, questions and answers or anything like that..."*

What are the "facts" that Ethan dismisses? Days, children and deeds. Unconsciously, these issues occupy Ethan. But he will not ask for details, because such questions would inflict a knowledge of Herman and Rebecca's specific history on him. As an `observer', Ethan can maintain a position of control: he can stop observing whenever the pain and horror grow too strong. As an `observer', he can draw conclusions and visualize images that are rooted in his inner reality. Although like Israela, Ethan avoids questions, unlike his mother, he is willing to come a little bit closer to his grandfather's experiences. When the interviewer asked Ethan what role he sees his grandfather in, he replied: *"As a servant, as someone who serves other goals, other things, serving his beliefs, in the Holocaust serving his employers, as an employee, serving his family."* When he was asked directly afterwards about Herman's relationship with Mengele, his reply was: *"I don't judge things without having been there. I believe that the man was completely incapable of doing any evil to any living thing in the universe."*

Beneath Ethan's argumentation, he has thoughts about the relationship between Herman and Mengele. Judging is associated with evil; "serving other people's goals" also relates to Herman and Mengele. Ethan is exposing his own latent, unconscious, questions about the past here. Ethan is holding an

inner dialogue that fluctuates between tentative glances into his grandfather's past and a censoring of all questions and curiosity that perpetuates this silencing of the past.

Blocking questions about the past is something that pervades all three generations. Rebecca reinforces these strategies. While she needs to talk about her own and her husband's experiences, at the same time Rebecca argues that the second and third generation should not hear about the pain of the past. The following dialogue exemplifies this structure: The German interviewer (1) asked Ethan: *"Do you have any idea what kind of images your mother has in her mind?"* Ethan answered this and the same question in reference to his grandmother, in the negative. Turning to Rebecca, the interviewer asked her: *"Do you want to tell him what your main images are now?"* When Rebecca declined, saying in English that her grandson was a self-assured Sabra, Ethan responded to this statement with non-verbal praise (a thumbs-up sign). After this, Ethan laughed about his grandmother's English and began a parallel conversation with his brother, who was walking around the apartment. At this point, Israela remarked: *"The big things, in general he knows, general things he knows, and she doesn't want to put upon him-."*

When relating to her daughter and grandson, Rebecca prefers to maintain the structure of blocked questions. She wants her 'Sabra' grandson to have no memory of the past so he will not be 'corrupted by recollections'.

While all three generations block questions, the nuances of the strategies they use to do so vary: while Israela, a member of the second generation, transfers the past into her own present to block all questioning processes, Ethan locates himself in the position of the observer, while carrying on an inner dialogue of questioning the past on a latent level. It remains an inner one, because the family system prohibits directly questioning Herman's and Rebecca's past. Another theme, that is blocked out and denied in the family dialogue, is the inner pain and suffering in the lives of the second and third generation.

### The denial of suffering

Throughout the interview, Israela latently blames her parents for constantly relating the present to the Holocaust. Speaking of her father, she says: *"He was in the Holocaust 24 hours a day"* and in reference to the denial of pain in her family, she argues: *"I was raised to deny suffering...not to speak about suffering...`we experienced it in the past and therefore we can overcome everything"*. And Rebecca explains: *"We wanted them to be happy children."*

From Rebecca's perspective, any suffering expressed by Israela could indicate a failure on her part to protect her daughter from the past, from pain in life. This attempt to block feelings of suffering is perceived by Israela as playing down the importance of her own experiences, her own difficulties. The

denial of suffering does not stop with Israela, but pervades the next generation, too. Ethan says of himself:

*"There's never been any discussion of suffering in this family...it has to do with...the Holocaust, she ((his grandmother)) and he ((his grandfather)) never talked about suffering to me...my best friend getting killed I don't think I've ever spoken a word of sorrow about it...that's just the way we do things as a family."*

Israela's response to Ethan's statement is: *"It is related to the Holocaust."*

The denial of suffering is a "genetic" message that passes from one generation to the next. But on a latent level, there is more to it than this: in the Sneider family, the perception of suffering is a complicated one. Herman's and Rebecca's positions in the Shoah not only bring up questions of suffering; they also pose difficult ethical questions. Because they held positions, where they were in charge of others, there is a feeling that relating to the narrative of the past simply in terms of suffering might give rise to difficulties. Rebecca says of herself: *"I had it best. Yes, primarily because I had a valuable job ((in the camps))."*

Holding a position of power, even as a victim, raises questions of ethics, and there is a fear that this aspect could overshadow the aspects of suffering. The persecution in Rebecca and Herman's past is in the shadow of the suffering of others. Thus, the theme of the denial of suffering is related to the terribly difficult questions that this family has to confront, questions that are concealed and silenced, like: What did Herman see? What happened to the children whom he could not save? What did Rebecca do in the camp? What did she do in the three positions she held?

"Outside agents"

The existence of "outside agents" emerges in the analysis of this family; people who can relate to the painful themes and to the myths that are blocked out of the family dialogue. Amnon, Israela's husband, takes on the role of such an "outside agent". As an analysis of the family interview shows, as an outsider in the family system, Amnon can permit himself to see things from another perspective. He is able to look at the grandparents' special positions and the difficulties that arise from them; he sees Herman's humiliation, his suffering and his shame. In the following sequence, Amnon clarifies this perspective:

*"One of the most terrible things you can do to a human being is to make him a victim, and put him in such a degrading system that will convert him, into almost believing...identifying with the role of the hunted animal, and mix the hatred with fear and respect for his tormentors and, he (Herman) had this respect...he would sometimes describe... Mengele in terms of tall, nice,*

*authoritative...He was brought to see himself as the subdued, degraded...I was a soldier in the air force, a high ranking officer and at times he would unconsciously play that subdued role with me, combining towards me some kind of mixture of respect and fear...I think I could identify it as copied from there...he would belittle himself in front of me".*

This sequence clearly shows Amnon's attempts to penetrate the myth of modesty imposed on Herman. Instead of seeing Herman in abstract terms or heroic conceptions, Amnon sees the complexity of Herman's tragedy. He tries to enter into the realm of Herman's experiences with Mengele. By doing so, he enables other family members to work through some of the themes that are taboo in the family dialogue.

### Concluding remarks

In the Sneider family, silence and secrets are used to hold back the past of the Shoah. The family dialogue is blocked when it comes to relating to Herman's and Rebecca's past. As a result, dialogues become monologues; a structure that deepens feelings of loneliness and solitude. A great fear of asking questions strengthens this structure of monologues, which is especially apparent between the first and second generations. It takes this specific form because of the specific experiences that the past hides: experiments on twins, atrocious torture, the actual laboratory of Nazi ideology, working with Germans and being responsible for the life and death of others. The question of collaboration by having a role involving power in the camp also shapes the structure of these blocked questions.

The second and third generation gain access to the past through other means. Both generations have taken on the grandfather's delegation to study and develop an academic career. Unconsciously, this repair strategy takes them closer to the grandfather's trauma in Auschwitz. Processes of working through the traumatic past take place in the form of inner monologues, abstract thoughts, concepts and experiences of self. The various myths - "modesty" and "hunger" - protect the family system from questions about the position of the grandparents.



## 8. Shared and divided worlds: The Stern family

Waltraud Schade, Sabrina Böhmer and Gabriele Rosenthal

### *The Family System*

Let us consider the genogram from the perspective of the parents' (or second) generation. The marriage of Stefan and Irit created a link between two families with very different histories and social and cultural backgrounds, the Plankas and the Sterns. The families have, above all, been affected in very different ways by Nazi persecution. The Stern grandparents did not themselves experience persecution because they had already emigrated to Palestine. The Planka grandmother, however, survived extreme persecution, and two of the Plankas' children were murdered in the Shoah. A look at the family biographical data will help us orientate ourselves in the family system. Some preliminary questions and readings will serve as points of reference in the analysis of the life stories.

Let us start with Stefan's family. His parents, Nathan und Martha, emigrated to Palestine in 1936, shortly after they married. Two years later, in March 1938, Austria was annexed and absorbed into the German *Reich*. Nathan Stern was born into a prosperous Jewish family in Vienna. He studied medicine and qualified as a physician before his marriage. Martha grew up in a Catholic family in a small town near the Ebensee Lake. Her father was a casual labourer, her mother a cook. After training as a seamstress, Martha worked as a nanny for Jewish families in Vienna. Through her work, she got to know Nathan. Before they married, she converted to Judaism. On the basis of this biographical data we might surmise that both of their families of origin had reservations about the marriage. The question of Martha's motivation will be addressed below. Was her conversion to Judaism the result of religious conviction or was it undertaken "pro forma", so that their marriage would be recognized as legitimate by Jewish institutions and the children would, under Jewish law (*halakha*), be Jewish?

Stefan was born in 1937 in Palestine. Nathan and Martha's second child, Artur, was born in 1944. Nathan had a very successful career as a physician in Israel. The family spent the years 1946 to 1950 in Finland, where he pursued advanced professional training. During the four years Stefan spent away from his country of birth as a child, the state of Israel was founded and the War of Independence fought (1948). Later we will consider the significance for Stefan of the years he spent abroad.

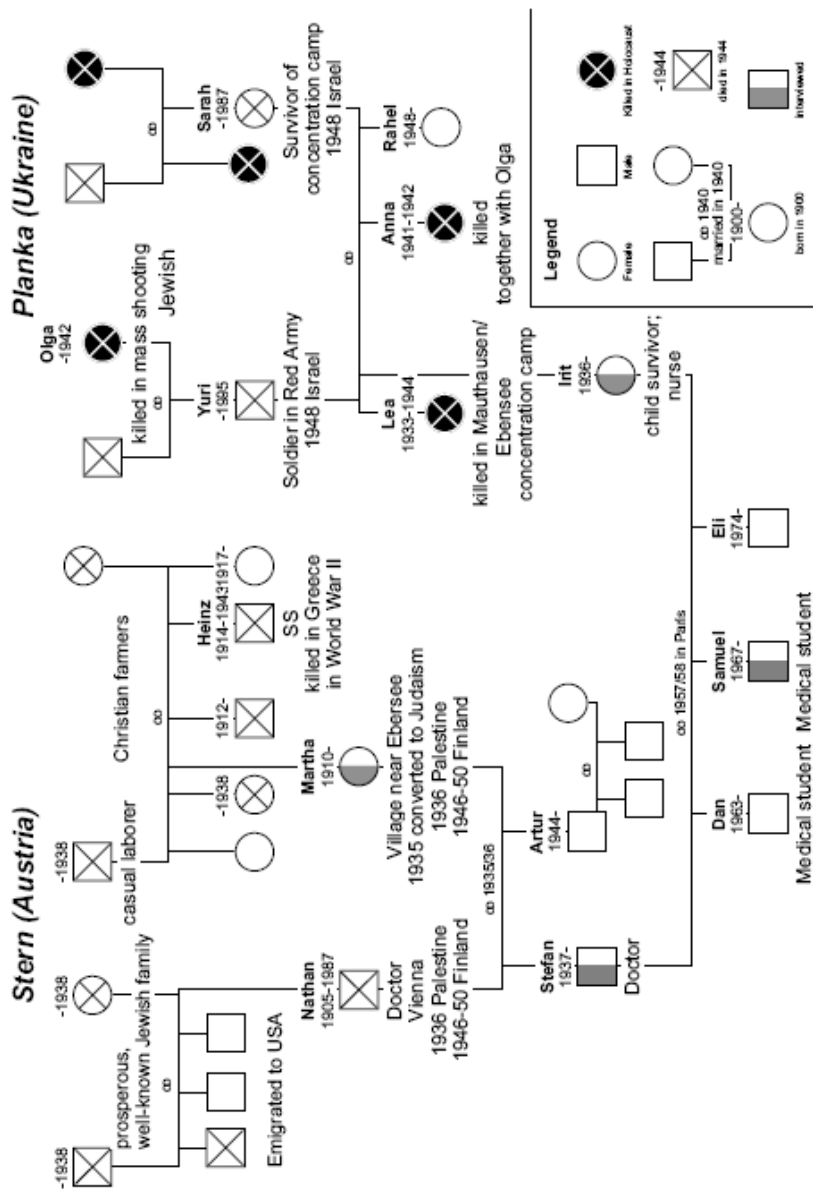

Figure 2: Genogram of the Stern family



While serving in the army, Stefan got to know Irit Planka. Irit trained to be a nurse, and Stefan studied medicine. They both went to study in France and married there in 1957 or 1958. Like his father, Stefan also continued to study in Europe. Stefan and Irit have three sons, who have also made a successful start to their careers, following the tradition of their father and their grandfather.

Let us turn to Irit's family of origin. She was born in 1936 in a small town in the Ukraine, which belonged to Poland until 1939. Irit had an older sister Lea and a younger sister Anna. Of the three, only Irit survived Nazi persecution.

Irit's father, Yuri Planka, was drafted into the Red Army in 1939, after their home area was annexed by the Soviet Union. He spent the war serving in a supply unit. He saw his oldest daughter Lea for the last time when he was on leave from the front. He never saw Anna, who was born in 1941. Irit and her mother Sarah survived the ghetto, the Auschwitz-Birkenau death camp, the Mauthausen concentration camp, and its sub-camp at Ebensee. Irit's grandmother Olga and Anna were killed in a mass shooting. Lea was murdered in the Ebensee concentration camp. Sara managed to have Irit smuggled out of Ebensee in 1944 or 1945 and hidden on a farm nearby. After she was liberated, Sarah did not try to contact Irit at first, who was then eight years old. When Sarah and her husband Yuri met again in 1947, she still did not know whether her daughter had survived.

It was not until shortly before they left for Palestine in 1948, that the parents met Irit quite by chance, in a refugee camp in the south of France. Irit was then twelve. Reunited, they emigrated to Palestine and lived there together as a family. Irit's sister Rahel was born in 1948.

The following questions will be addressed below. What effect did the marriage of Irit and Stefan, a survivor and a Sabra, have on the family dialogue? What experiences have been transmitted within the family, and which members of the family are interested in and identify with which parts of the family's past? We will also consider the patterns of identification available for the third generation within the Planka/Stern family to adopt.

### *Irit: Waiting in vain for her mother*

Irit was born in the Ukraine in 1936, her sister Lea was three. Her paternal grandmother, her mother's sister and the sister's son all lived with the family. In 1939, Eastern Europe was divided into a German and a Soviet sphere in accordance with the Hitler-Stalin pact, and Soviet soldiers occupied that part of the Ukraine. Irit, then three, was separated from her father Yuri. He was drafted into the Red Army and, as a car mechanic, served in a supply unit. His family stayed in their hometown and would not move, even when Yuri, home

on leave, insisted they leave town. After the German invasion in 1941, life for the five-year-old Irit and her family underwent a dramatic change. Attacks on Jewish people were stepped up and many fled. Despite the worsening situation, Irit's mother Sarah decided to stay. She was forced to work for the Germans in a laundry. The German Wehrmacht moved on, and the SS troops that came after them established a ghetto for the Jews in the town. The Plankas had to share cramped quarters with other families.

Irit<sup>53</sup> recalls that she and her mother became very close during the time in the ghetto and that they would only leave the house together. She often saw people being beaten on the street or subjected to random identity checks. In summer 1941, the Nazis ordered Jews to wear a star in public. In order to hide hers, Sarah, who was pregnant with Anna at the time, would often carry Irit on her arm. They endured many frightening situations, when Germans claimed the blond and blue-eyed Irit could not be the daughter of a woman with black hair: *"It happened many times that, they took me from my mother, they said, "That's not your child." Actually, my mother, she used me as an excuse<sup>54</sup> for many things. She almost never went anywhere without me."*

The statement, *"she used me"*, indicates, from Irit's present perspective, a latent accusation against her mother.

The situation in their town was becoming ever more dangerous. The family was particularly frightened of the Germans' brutality towards small children. Anna had been born by now. Once Irit and her grandmother had to go to the town high school, her mother and other women were also brought there. Irit started to cry when she saw her mother, and her mother picked her up. The women were all taken to the gym; the floor was covered in broken glass. On benches along the walls were Ukrainians with whips. They forced the women to walk barefoot over the glass: *"and the women had to march back and forth over the broken glass" until the room was "full of Jewish blood."* Sarah Planka was frightened she might fall and tried to protect her little daughter's back with her arms. Then she stumbled and they fell; the glass cut deep into her mother's arms; Irit was also hurt. She screamed in fear and pain. Then she saw a neighbour of theirs at the other end of the hall:

*"Our neighbour a Ukrainian who really he and my mother they went to the same school since they were little. And on passover they always came to us because they liked to eat the matzos. My grandfather, when he bought the matzos, he also gave some to them. We got bacon from them. It was like one family. And when I saw him I thought he will save us, but, well-."*

---

53 Cf. the detailed case study in Schade (1995). Irit was interviewed by Gabriele Rosenthal in 1991 in German.

54 Underlining signifies words that were spoken in English in the otherwise German interviews

The image of the bleeding and screaming women still torments Irit today. Soon after that, at Whitsun 1942, the family along with the other residents of the ghetto were driven into the marketplace. The grandmother and mother stood on either side of the children and tried to shield them as a crowd of Ukrainians hurled abuse. Among them were many peasants who had come to sell their products at the market. Irit knew them: *"The people they were really a part of our life we would go with grandmother to the market and buy geese from these peasants and the peasant would bring us carrots. Those were all people they were like a puzzle in our life."*

The people standing around gestured quite unambiguously that they wanted the Jews, herded together on the marketplace, dead. The grandmother kept telling Irit, then five, and Lea, nine, to keep their heads down and not to look around. Then they were all driven through the town and into the forest. Irit was frightened of losing her mother and grandmother. When they reached freshly dug pits among the trees, they were divided into groups: *"And it was terrible that they were all naked, all of them, men and the elderly and children, and they all had to stand there naked and everybody, each felt the other's presence."*

Group by group, they lined up at the edge of the pit and were shot by the SS men. Irit and her family were standing some way away but she heard the shots: *"My grandmother had the baby on her arm. It was nine months old then, I and my older sister were with mother."* She sensed the adults' fear and heard them say: *"Try and push the children towards the back, don't let them stand with you."*

The children were pushed towards the back. Irit witnessed how her grandmother holding Anna on her arm was shot and killed. Irit, Lea, and their mother Sarah only survived because the Germans ended their 'Aktion' (killing operation) punctually in the afternoon: *„Because they worked according to time, no later than three. Everybody still remaining we all marched back to town."*

They were all driven back into the ghetto. While they were gone, their quarters had been ransacked and plundered:

*"And when we returned in the afternoon from the graves, they, the Ukrainians, were inside the houses and took everything. And the washing ((that had been hanging on the line)) they lost some of it along the way. And there was a short white coat of mine, it was there and I can imagine that I didn't cry that my sister is gone and didn't come back with us, or my grandmother. But I cried terribly that someone wanted to take that white coat away from me. And I was so happy that it was still there."*<sup>55</sup>

---

55 Laub and Auerhahn (1991, p. 261) also describe the phenomenon whereby things replace people for children who experience frightening events: "If a close relationship to those nearest to them appears too dangerous, inanimate objects can take their place".

Later, her mother told Irit more about the children's reactions to what was happening:

*"My mother says I asked a few times I asked when, when is Anna coming back and grandmother and they told me and that was the end of it. (5) But my mother says that, the older sister cried a lot that they take back she wanted to see where=where the grandmother is buried they said you can't go there."*

Unlike her sister who was nine at the time, Irit, then six, was not able to fully understand what they had witnessed or fully appreciate its meaning.

According to Irit, the ghetto was liquidated in 1943<sup>56</sup>. The six-year-old Irit, her ten-year-old sister Lea, her mother and aunt were deported to Auschwitz-Birkenau. They travelled in an overcrowded truck. Inside it was dark and there was no water; people were forced to relieve themselves in the truck. Many died. Irit sensed the powerlessness of the adults and did not ask any questions:

*"When we arrived then we all had to get out. And there were terribly many people. The SS, they were there with dogs, they waited for us and drove us to Birkenau. We went into the barracks and some of the older people stayed ((behind)) but it wasn't a real Selektion."*

Irit can hardly remember that time: *"I can't remember exactly what it was like. I know we went into a room and I was on my mother's lap and they took our hair away."*

Irit, her mother, sister and aunt were then sent to Mauthausen. After an unspecified period of time, the women and children were taken to the Ebensee sub-camp beside the lake of the same name.<sup>57</sup>

Irit can scarcely deal with this period of persecution emotionally. As a child, she appears to have reacted by closing off psychologically (cf. Lifton 1968) or with the automatization of ego functions (cf. Niederland 1968); even today, she still has to protect herself from the associated feelings. Yolanda Gampel (1988; 1992) has written about this closing off in child survivors she has interviewed. Their most common symptom was an inability to cry, before and after they were liberated: "The ego of the Shoah child was forced to function automatically and without expression of feeling" (1992, p. 391). That enabled the children to behave like adults. Irit has virtually hypermnestica memories of some of what happened, memories that are extremely clear (cf. Niederland 1980) but *"without feeling"*, as she puts it. It is striking that in her narration Irit did not use the German words for 'feeling' or 'emotion':

---

56 According to Hilberg (1982, p. 271), the liquidation took place in 1942.

57 This camp was set up on 8 November 1943 and was liquidated on 6 May 1945 (cf. Schwarz 1990, p. 175).

*"I can remember things very precisely, but they are like separate images without connection, it is, it is very hard for me to go back to feelings, how, what I felt, was I frightened or was I very content, my emotional state, that is blank. I can't remember at all what my emotional state was like."*

In the camp, the people were starving. Mrs Planka tried to obtain food for her daughters. They often sensed her despair: *"and on such evenings when my mother came back and, I and my sister were sitting there crying. And mother cried because she couldn't give us anything, she couldn't hide anything or bring us anything."*

Irit said that while she spent the days trying to "organize" scraps of food, Lea became ever more passive and apathetic. Like the other children, Irit had to overcome her terrible fear of the dogs; she went out and came back with things for Lea to eat. These scenes in the camp are among the few memories of her older sister that Irit mentioned during the interview:

*"She too is so blurred because she really she suffered very much, Hunger, she was not at all active with me to get food or to find some, she was always near the barracks, she did not go away. When I brought her something, she took it. But herself, she didn't, and I, when I think about it now and I try to interpret that, I think it was perhaps one of the reasons why my mother thought she won't live but that one will live."*

Her mother gave Irit encouragement and new strength by letting her know of her conviction that Irit would survive. Sara Planka woke Irit every night and gave her precise instructions as to what she should do if they were separated. She told Irit over and over again where she should go and who she should look for:

*"and she kept asking me, what is your name? What is the name of your father, the name of your mother? Where will you go when it is all over? Palestine. And who will you look for in Palestine? My grandfather. And where is your grandfather? His name is Moshe and he is in kibbutz G. Good, now you can go to sleep. And two hours later she wakes me up again. What is your name, and so on, every night. Every night."*

Years later, Irit wanted to know from her mother: "'Why did you never, ask Lea that, did the same with her.' She said: 'somehow I had the feeling that the only one to survive will be you. Your sister will not live.'"

In the winter of 1944/45, the situation in the camp became even more extreme. The Allies were getting closer, and the guards were nervous. The man in charge of the workshop advised Sarah to smuggle Irit out of the camp. With a heavy heart, Sarah decided to separate from her daughter. Irit escaped hidden in a barrel filled with scraps of food that was picked up and taken to feed pigs outside the camp. As they said goodbye, Sarah promised to come

and fetch Irit as soon as the war was over. Irit lived in a lean-to in the cowshed on a farm. The farmer's family knew that she was Jewish and were frightened she might be discovered. They treated her ambivalently:

*"When the nights were so cold and snow, I always, the old grandmother walked around and made the sign of the cross and, ((imitating her voice)) 'Oh Jesus, oh Jesus, this little child it will perforce freeze.' And I always thought, now I could say 'Here I am, you can take me.' But I was also frightened so I stayed quiet."*

During this period in hiding, the eight-year-old Irit was left entirely to fend for herself and was very lonely. In the interview, she said she had nobody to talk to and only thought about what she had gone through and about the loss of her family when she was sent out into the forest with the cows and the pigs: *"I made lots of crosses out of wood for graves, I always found a little bird that I had to bury and a frog."*<sup>58</sup>

We can see this as her, through play, actively dealing with the fact that she had no place to mourn her dead.<sup>59</sup> She longed for her mother. The Hope, that she would soon come back, gave Irit courage and strength. After Germany capitulated in May 1945, the farmer talked to Irit about what she should do. He wanted to try and find her mother but offered to let her stay with his family if that failed. She waited for her mother, hoping intensely that she would keep her promise and come for her. Irit expected her to appear any day, but she did not come. After waiting in vain for two years, Irit was taken by the Joint (American Jewish Joint Distribution Committee) to a camp for children in Bad Reichenhall in Germany to prepare to go to Palestine. From Bad Reichenhall she was taken to the south of France, where in 1947 she unexpectedly met her parents. The meeting with her mother proved very disturbing and frightening for Irit; her feelings for her mother are very ambivalent.

On the one hand, there is a special closeness that derives from the time of the persecution they underwent together:

*"It was enough for us both to have seen something or looked at it, and we could, either the situation or the association with that moment with the past and laugh, or be sad and, we didn't need to talk at all we could look at something and in one second we think exactly the same thing."*

On the other hand, Irit is disappointed that her mother did not come for her after the war ended:

*"Years later I accused my mother many times, you didn't look for me I waited so long for you and you didn't come. My mother said that she, that all those years she was terribly frightened of looking for me, that they tell her I*

---

58 Note that Irit used the Christian symbol of the cross to mark the graves.

59 On the significance of play, cf. Eisen (1988).

*perished she says she know many other children died she says the idea that you are not alive and I don't know why not, that you died that was so hard the she decided not to look for me."*

It is hard for Irit to understand her mother's situation at that time, her feelings, and her actions. Again and again she asks why her mother never tried to find her. The intense and stabilizing closeness to her mother during the persecution helped Irit to survive. Later, while she was separated from her mother, it also underpinned her will to survive. The decisive traumatic turning-point in Irit's life came with the deeply painful realization that her mother had not tried to find her. A further indication that that is the case is that, in the interview, Irit ended her main narration with her reunion with her mother in the south of France. The traumatization through the loss of trust in her mother came at the end of a process of sequential traumatization over a number of years (cf. Keilson 1979).

Irit presented herself in the interview as a disappointed and abandoned child that only survived persecution on her own strength. This probably has a lot to do with Irit's feelings of guilt about her mother's decision to smuggle her and not her sister out of the camp or, to put it bluntly, her mother's decision that Irit would be the one to survive. She had hardly anything to say about her older sister Lea, who was murdered at Ebensee after Irit had escaped. She talked most about how she brought Lea food in the camp and stressed Lea's passivity.

In 1948, the family emigrated to Palestine. Adapting was a great challenge for Irit. She was twelve when she entered fourth grade. She had problems with the language; she could not read, write or count. In order to make contact with other children, she told her schoolmates "stories" from her past. But their parents were outraged. They said Irit was retarded and should be taken out of the class and sent to a special school. Irit experienced this marginalization as another existential threat and was seized by panic. She saw that stories about how she was persecuted provoked reactions of shock, paralysis and horror. This in turn convinced Irit that she could not make others understand what she had gone through - something other survivors have also reported (cf. Laub/Auerhahn 1991, p. 262). Other people's doubts about the reality of her experiences reinforced Irit's bond with her mother, who now became for Irit a 'guarantor' of the reality of her past. Sarah could confirm that her daughter's stories were true. She was also the only person with whom Irit could talk about her memories: *"And for years I sat with my mother and I always asked, now listen, I will tell you something, tell me, was it a dream or was it true?"*

Irit's teacher encouraged her. She made Irit promise to work very hard the next year, to concentrate on her school work and not on making friends with other children. Irit followed her teacher's instructions, and the following year, she managed to move up to the grade that corresponded to her age group. The

year after, she skipped a grade. Success at school helped Irit become more independent. She developed her own system of relevance, which allowed her to draw a boundary between herself and her past and thus between herself and her mother. The textual structure of the interview makes this very clear: Irit distinguishes clearly between the period of persecution, in which her mother is a central figure, and her life in Israel. In her narration, the separation of past and present is manifested in the following sequence, which followed her account of seeing her mother again in the south of France: *"How everything that happened happened, that is one chapter, and now an entirely different chapter begins."* She calls her life in Israel *"the new life"* and when talking about it hardly mentions her mother. Her achievements at school and her subsequent professional success helped her to live with the trauma of persecution she had suffered as a child, to mitigate it and, above all, to face actively her fears and the helplessness she had experienced.

After graduating from high school, Irit trained as a nurse for three years and then went into the army, where in 1955 she met her future husband Stefan, who was then nineteen. In 1957 they both moved to Paris to study. A short time later, they sent their parents a telegram letting them know that they had married. In explaining the decision not to marry in Israel, Irit said she had been frightened of explosive emotional scenes among her parents' friends, like the ones she had witnessed at other family events:

*"and their children aren't alive, some of these people who ran away back then ((from the ghetto)) live in Israel today. They were very pleased when they heard that I was alive but many times it was like this, 'If our child were alive now, she would also have done this or that'. I said no, all the years I took it but my wedding, no. I don't want anyone to be there."*

By marrying into a Jewish family that had emigrated from Austria early and thus escaped persecution, Irit entered into a different family system with a different past, a family which also has Christian members. This probably corresponded to her need to separate her *"new life"* from the past in which she had suffered persecution. In the Stern family, she is only rarely reminded of her own family. Irit also marked her entry into the new system by living in the house of her parents-in-law with her husband and children for some ten years, between 1963 and 1973. Her mother-in-law Martha looked after the children while Irit and Stefan were at work. The relationship between Irit and her mother-in-law is problematic. Martha Stern demanded from the start that Irit speak German: *"The German language, it was so hard for me, being in Israel and hearing the language that was a connotation with my past, that his mother said I must speak German."*



The significance of Martha's Christian family of origin for Irit was only addressed indirectly in the interview. Irit mentioned a plan to visit Stefan's grandmother in the Tyrol. She can remember vividly the ride in the post bus from Italy in the direction of Austria: she enjoyed the beautiful scenery. Then they reached the border and were waiting to have their passports checked:

*"We arrive at the border and I am sitting with my husband and we look at the map and the bus stops and I look out and I see - my husband says I was completely white. I say, Stefan, look, there are the SS men. He says, what are you talking about? And it was right the police who were standing at the border they have green uniforms they have the same hats. That was in fifty seven, and for me that was exactly the way I knew them in the camps. I say no, I am sorry, I am not going any further."*

Irit was seized by panic and broke off the trip. Seeing the uniformed border police, she suddenly felt she was back in the camp. She felt so threatened that she has never since gone to Austria and never met her husband's grandparents or other Christian relatives.

After they finished their studies, Irit and Stefan returned to Israel. Their first son Dan was born in 1963, their second son Samuel in 1967, the youngest son Eli in 1974. For Irit, as for other survivors (cf. Kestenberg 1991), her children are a sign of triumph, a sign that she has survived and created a 'new life' in Israel:

*"When the children were born ((laughs)), that was (3) really the peak of it all, because that was (2) many times in my life when I did things and they were successful, very successful, then I had the feeling, they didn't kill me and now I can do this and do that and I do it so well, and I do it so well, but actually, they wanted to kill me."*

### *Martha Stern: "Our life wasn't so eventful"*

Irit's mother-in-law played an important role in the family. For many years, she looked after Irit and Stefan's sons. The interview with Martha Stern<sup>60</sup> was conducted in 1995. She seemed disconcerted when first asked to recount her family history and life story. Although she had a long and eventful life to look back on, she tried to present her life as "not worth mentioning": *"We just lived our lives quietly I mean (4) the children, they learned something (2) and (3) it wasn't so eventful our life thank God it wasn't I mean we are a normal family."*

Let us review some of the periods in Martha Stern's life. She was born in 1910 in a small Catholic town in Austria. Her two older sisters had already

---

60 Martha Stern was interviewed by Bettina Völter in 1995 in German.

been sent to live with their mother's sister, quite possibly because the parents were poor. Martha's mother was a cook, her father a casual labourer. Their fourth child, Günter, was born in 1912. Martha's brother Heinz was born in 1914; little Elisabeth, in 1917. As the oldest child in the family, Martha soon had to take on housekeeping duties and look after her younger siblings while her parents were out. In the school holidays, she often went to stay with an uncle, who lived with her paternal grandparents. He was a priest, as were her other paternal uncles: *"My father's four brothers studied to be priests. That's about the maximum."*

Although she had a large family when she was a child, Martha tried to present herself in the interview without reference to her family. When asked to tell us about her family history and life history, she began by talking about her apprenticeship as a seamstress, which began in 1926: *"My mother always thought a trade was a goldmine and so I had to learn to be a seamstress, even though I hated it."* This statement suggests her parents were authoritarian, forcing their daughter to learn a trade she said she hated. After completing her training, Martha continued to live at home at first. But shortly thereafter, she lost her job and decided to move to Vienna, where she found work as a nanny in a Jewish family. Turning to the interviewer, she said: *"So write down: a higher class of nanny. Really! ((laughs)) So that's how I came to Vienna and that's what I did and: (2) I was really quite content. But I must say that I was almost always in Jewish houses."* Her social advancement back then to a *"higher class of nanny"* in Jewish houses is still of importance to Martha today.

Martha grew up in a traditional Catholic environment. She attended Catholic school, went to church regularly, and sang in the church choir. Moving to Vienna, she left her family and entered an entirely new milieu, the world of *"Jewish houses"*, a realm she locates in the thematic field of *"wealth and status"*. While the biographer links the Catholicism of her own family to its poverty, she connects Judaism with prosperity and status. Her time as a nanny, from about 1930 to about 1935, is the horizon against which, in her biographical self-presentation, she introduced her future husband Nathan: *"I went to the mountains in the summer with the child ((that she was looking after)) and so forth, you see. And then I met my husband and that was that. Then we came here."*

In her main narration, she mentioned neither Nathan's background nor her own conversion to Judaism before their marriage. Martha spent just ten minutes during the interview talking about her family history and life history. The biographical self-presentation ended with her emigration: *"that was that. Then we came here."*

Let us look more closely at her migration from one milieu to another in the light of information derived from the interview with Martha's son Stefan. By marrying Nathan Stern, a medical student from a good family, Martha

escaped poverty. She was twenty-six, he was thirty-one. Nathan came from a very prosperous and respected Jewish Austrian family. His three brothers also went to university. After finishing his studies, Nathan could not find work as a physician because of growing anti-Semitism in Austria, Nathan decided to emigrate to Palestine with Martha. For Martha, emigration marked yet another turning point in her life. After having left her family and the milieu she grew up in, she now changed her cultural sphere again.

Martha came from a milieu and a family in which there was anti-Semitism. Some members of her family identified with National Socialism. In the interview, Martha recounted how she introduced her husband to her parents. Martha said she could never have taken Nathan to her hometown because of the risk of anti-Semitic violence: *"I didn't go to S., I would never have done that, some one or other might have thrown him a punch, perhaps nothing would have happened, but just to risk it."* So they met her parents in her older sister's inn outside of town.

Martha's son Stefan told us that her younger brother Heinz had been in the SS. Martha conceded that her brother was pro-Nazi, but she did not mention the SS and tried to make his *"activities"* appear harmless: *"I almost think he didn't half enjoy being a soldier. They had some hard years ahead of them, the great unemployment. That all left its mark."* Both Martha and her son said Heinz was a paratrooper and was killed in 1943 on Crete.<sup>61</sup> Martha said he had been a waiter but became unemployed and then *"the war came while he was still a sports instructor there-"* and then she suddenly stopped. What did she mean by *'there'*? Was he a *'sports instructor'* for the SS, and did he stop being unemployed when he joined the SS? All Martha said about Heinz's political involvement had to do with his activities in the Hitler Youth. This is informative. One had to be under eighteen to be a member of the Hitler Youth. Heinz turned eighteen in 1932. If he continued to be active in the organization after that, then as a youth leader (*Führer*) in the illegal Nazi youth movement, since the Nazi party and its organizations, including the Hitler Youth, were banned in Austria in summer 1933 and remained so until the *Anschluss*, Germany's annexation of Austria, in 1938.<sup>62</sup> By only mentioning that her brother was in the Hitler Youth, Martha played down the significance of his involvement with Nazi organizations. What effects did her concealment of this part of the family history have on her family?

Martha said very little about her wedding. She indicated that none of her family attended the ceremony: *"It was only Nathan's family and no one else was there and I was there ((laughs)) I mean alone"*. Nothing in the interview indicated how Martha's family felt about her Jewish husband. One might infer from their absence from the ceremony that they were not entirely pleased

---

61 The SS began the mass deportations of Jews from Greece in March 1943.

62 Compare the case study of a Hitler Youth leader (*Führer*) in Sieder 1995. Only a hard core of youths remained active in the Hitler Youth after it was banned, in "illegal struggle".

about the marriage. Even before she chose to emigrate with her husband, Martha had already separated from her family of origin through her marriage and the preceding conversion to Judaism: „*That was really something, wasn't it, when I became Jewish if that interests you ((laughs)) I will tell you I don't remember much about it because I found it unpleasant there's a-you have to go to a bath.*”

"Becoming Jewish" is not presented as a process of changing attitudes but as a "*something*". Martha Stern distanced herself from her conversion and from "*being Jewish*". She found the bath ((Mikvah)) unpleasant. We cannot, however, say whether she also found the entire ritual of conversion unpleasant. Perhaps her feelings about conversion had to do with a conflict of loyalty between Judaism and the Catholic Church. Later in life, in Israel, Martha tried to create a certain continuity with her Christian past. For example, she celebrated Christmas with her family and installed a decorated Christmas tree in the living room.

While her husband soon found his feet in their new home country, at least through his work, for Martha the country remained alien. After sixty years, her command of Hebrew is still rudimentary. She brought up her children and grandchildren speaking German.

What did Martha's demand that her daughter-in-law Irit speak German mean for Martha? By holding on to her mother tongue, she maintained continuity with her past in Austria. Irit's entry into the family may well have drawn attention to questions that had long been avoided about Martha's past and her family history. Perhaps Martha felt threatened. The very first time she met Irit, she attempted to assert her dominance by stating: "*German is spoken in this house.*"

Martha also consolidated her position in the family system by looking after her grandchildren. After Nathan's death in 1987, her grandchildren, the children of her second son Artur actually came to live with her.

What role does her older son Stefan play in the family? His parents emigrated early and did not experience persecution "directly". There were Nazis in his mother's family. His wife survived persecution as a child. Stefan's maternal relatives lived very close to the concentration camp where Irit, her mother, and her sister Lea were held and where Lea was killed. This adds a further threatening component to the family constellation.

### *Stefan Stern: "I had to take a stand and I took a stand"*

In 1950 Martha and her thirteen-year-old son Stefan<sup>63</sup> visited her mother, Stefan's grandmother, in their hometown in Austria, near Lake Ebensee and

---

63 Stefan Stern was interviewed twice within one week by Bettina Völter in German in 1995.

not far from the former outlying sub-camp of the Mauthausen concentration camp. In the interview, Stefan only mentioned the visit after he was asked whether he had known his maternal grandmother:

*"I saw her once she was a very old woman (4) and, (2) the German they speak there in ((deep breath)) Upper Austria you can understand it with difficulty. But we had very little contact. I don't remember it anymore (2). Well, as I said, we grew up without a family."*

Stefan tried to preempt further questions about his maternal grandparents and relatives. He said he did not remember them and wanted to change the subject. A short while later the interviewer asked Stefan when he had realized that it might be meaningful for him, too, if he were to deal with his wife's past. He replied:

*"It just came together, slowly, like a puzzle, a picture (1) from things. (6) My wife was in a concentration camp at the time, which (2) wasn't far (2) from (1) the little town. I was there near the place on a boat ride before I knew that it, that there was a concentration camp nearby ((laughs silently)) (2). Of course everybody in the area knew that there was a concentration camp there but of course nobody talked about it. (7) It was very nice...and then suddenly there was a great storm on the lake but we made it back. And (2) many years later (1) my wife told me about storms there had been on this lake (1). It was quite clearly the same lake...but she was a terrified little girl in a concentration camp and (1) I was there as a little tourist who was visiting his family in Upper Austria."*

The persecution his wife had suffered was also brought home to Stefan by the fact that his family lived so close to the camp Irit had been in: it slowly came together like pieces of a puzzle. Let us stay with this image of a puzzle: we might suppose that some of the pieces between the two family groups are still missing and that Stefan does not want to look for them. He said he did not want to think about his mother's family any more or about whether members of the family had witnessed or taken part in Nazi crimes. His statement, *"Of course everybody in the area knew that there was a concentration camp there but of course nobody talked about it,"* is an implicit accusation of his family. Saying he had been in danger - from the natural force of a storm - during his visit to his family's home near Ebensee, he was in a certain respect identifying with his wife. One might at first infer that, in talking of the storm and saying *"but we made it back"*, Stefan was drawing a parallel between himself and his wife, who had made it back from the camps. We saw that in Achim Svoboda (cf. Chapter 2.2.). But Stefan also stressed the difference: while his wife was a *"terrified little girl"*, he was a *"little tourist who was visiting his family."*

Let us review Stefan's biography. He was born in 1937, one year after his parents arrived in Palestine. When he was born, one could not have predicted

that a Jewish state would be founded. His parents' life was oriented toward Europe. They spoke German and Stefan learned no other language until he was three. His nanny also spoke German. The family celebrated Christmas. In kindergarten, Stefan was expected to learn Hebrew; he had little contact with the other children and did not feel at ease in the group. He often ran away and went for walks alone.

Stefan felt isolated because he was being brought up speaking German. He felt it was a barrier that prevented him from making friends and above all from feeling that he belonged in the country where he was born. In contrast to home, Stefan discovered that at school Christian symbols were spurned: *"In my time we weren't allowed to make a plus sign because it is a cross. The plus sign was, the bottom part was missing so it wouldn't be a cross. That can only show how hard these things really were."*

Stefan was seven when his brother Artur was born in 1944. Two years later Nathan Stern decided to go with his family to Finland for further training as a medical specialist. Stefan had to adapt to a new language yet again. He was sent to a Finnish school. He enjoyed living in Finland. His teachers helped him. They practiced the language with him after school, invited him to their homes and helped him make contact with other children: *"Yes, it was a good time, I learned Finnish very fast"*.

In 1948, the British mandate in Palestine came to an end. The Sterns were still abroad when the state of Israel was founded and during the War of Independence. They returned in 1950 and moved back into their old house. While Stefan's father settled in quickly and soon became successful in his profession, it was much harder for the rest of the family to adapt. Artur, now six, had to learn Hebrew from scratch and Stefan, now thirteen, had to readapt once again. He had not enjoyed a common socialization with his peers at school. Above all, he could not share with them the period of the founding of the state and the War of Independence. We can infer that, in addition to the usual problems of adolescence, it was difficult for Stefan to feel that he belonged in Israel. His mother's non-Jewish family background did not make it any easier for him to establish a sense of belonging; it offered little with which he might identify. During the interview, we could sense Stefan's ambivalence towards his mother's Christian family.

The cultivation of Christian traditions in his parental home bothered the adolescent Stefan, and the silence within the family intensified his insecurity about where he belonged. Stefan also felt his mother's conversion to Judaism had been imposed upon her and was not an expression of her own needs: *„She wanted to marry my father and then she had to convert to Judaism. If they had gone to America, they would probably only have had a civil marriage somehow. The ceremony or what went along with it was totally alien to her but it was totally alien to my father as well."* Stefan can also adopt the perspective of his maternal grandparents: *"I think it was very hard for the*

*whole family. It was probably very serious, to marry a Jew. They believed Jews had horns."*

Stefan also made clear that there had been anti-Semitism in his mother's family: "I think they were anti-Semitic everywhere in Austria, even if they had never seen a Jew. I don't think much has changed."

Indirectly, Stefan addressed his problem with having a sense of belonging right at the start of the interview. He began by saying that he had been in Palestine throughout World War II and added: "*So I don't really have any war memories from my childhood.*" In response to the interviewer's remark, "*So you surely have memories of war here in Israel,*" he said, as if to justify himself, that he had been drafted in both the Six Day War (in 1967) and the Yom Kippur War (in 1973). Stefan addressed the theme of the absence of memories of wartime from his childhood. It is not certain whether he meant the Israeli War of Independence or the World War II in Europe, which his wife had experienced as a child.

Irit and Stefan met while he was serving in the army. He enlisted in 1955 and served during the second Suez crisis<sup>64</sup> as a medic. In the interview, he said it was through Irit that he was first confronted with the theme of Nazi persecution: "*That was really more the first time that (I) the problem from that time or the Nazis at all in a more personal way that I heard anything (I) more about it through her. Before that it was a theme that one did not talk about.*"

So Stefan already knew about the Shoah, but not in a "personal way". Presumably Irit was the first survivor with whom he had closer personal contact. There was no one in Stefan's family who could have told him "in a personal way" about the Nazi period. His parents preferred to avoid the topic. Stefan began to face the theme of Nazi persecution of the Jews at the same time as survivors started to make public statements and testify at the Eichmann trial, which began in April 1961. That is when the theme first entered public discourse in Israel: "*Hard to say, when I heard of it for the first time, probably at school but one didn't have any kind of clear picture of it. The Eichmann trial was the first clear experience.*"

Stefan recounted what happened when he first presented Irit, then twenty, to his parents and how restrained and distant his mother was. He also mentioned that she required Irit to learn German: "*Irit learned German after she got to know me. Through my mother who said, 'In our house German is spoken, only German' ((laughs)).*"

---

64 After President Gamel Abdel Nasser intensified the blockade of the Suez Canal in September, Israel could not use the harbor in Eilat or import Iranian oil. In late summer 1956, Britain decided to regain control of the canal. In order to do so, Britain, France and Israel signed a secret deal that foresaw an Israeli invasion of Egypt. For more on the Suez crisis, see Schreiber/Wolffsohn 1989.

Stefan was and is more or less helpless in the face of the conflicts in the relationship between Martha and Irit. In the interview, he interpreted it as a typical mother-in-law/daughter-in-law conflict and played down its intensity: *"Life isn't always a picnic. There were certain conflicts in the past and I had to take a stand and I did take a stand."*

Irit disclosed new realms of experience to Stefan. He tried to keep them out of his dialogue with his parents, presumably in an attempt to avoid conflict. Above all, he sees no sense in talking to his mother about the Holocaust or the fact that her hometown was so close to the concentration camp where Irit had been incarcerated. He believes he can sense his mother's unwillingness to discuss it:

Interviewer: And you think her family also knew at the time that there was a concentration camp there ((in Ebensee)).

Stefan: Definitely, definitely (4).

Interviewer: What does that feel like?

Stefan: (3) Like (2) how the world how strange the world is. I think it was a matter of fate.

Interviewer: Did you and your mother talk about that place?

Stefan: No, (1) no, she would certainly say that no one knew anything about it. There's absolutely no point in discussing these arguments.

In 1957, Stefan and Irit went to Paris together and married there. Stefan did not cite Irit's motives when he explained why they decided to marry without their families; nor did he say, as we might have expected, that they wanted a secular wedding, which would not have been possible in Israel. What he said was: *„I didn't want a wedding and such a lot of confusion. I said, a wedding is something for the people who are getting married, not for the others."*

What kind of confusion, one might ask. Perhaps the confusion of the various parts of the family. There are also certain parallels to his parents' wedding. His mother's family did not attend and that precluded possible conflicts.

The interview showed clearly that Stefan, like his mother, scarcely addresses the theme of the non-Jewish part of the family background. Stefan subsumes his mother under his father's family, about which he can tell anecdotes and stories. When asked about his mother's side of the family, he said: *"It wasn't (1) something that one (3) it wasn't an important part of our life in any way."* He described his relationship to his mother's family: *"I think I ignore my, (1) let us say (2) Upper Austrian ancestry."* But it was Stefan who told us that his uncle had been in the SS: *"And her brother was in the SS so that there was a (1) certain a serious conflict there (3). I mean my uncle ((said very quietly))."* After Stefan said this, there was a long pause, then he laughed and the interviewer also laughed. Stefan ended this sequence by say-



ing that his uncle *"was killed in the war"*. Asked what he associates with the SS, he said: *"marching and the (4) and naturally (2) the (2) concentration (2) camps and, gas chambers and so on."* Then there was another long pause, lasting 29 seconds. The ensuing dialogue made clear, how vivid the terrible images from the camps are for Stefan and also how he avoids making any connection between them and his uncle:

Interviewer: What's making you pensive now?

Stefan: What?

Interviewer: What's making you so pensive now? Are you thinking of the brother or –

Stefan: No, I'm not - so (5). I am thinking about (2) the crimes (5) about (1) the (2) terrible deeds of the (2) Nazis in the war ((very quietly)).

Interviewer: (4) Can you imagine the brother or (how) can you see them together? The crimes and the brother ((very quietly)) (3)

Stefan: No (1).

Stefan finds it threatening to think about a possible involvement of his mother's family in Holocaust crimes. Instead, he takes an interest in his wife's past, in her traumatic childhood experiences of persecution. He tries to avoid addressing the theme of the role parts of his family might have played as Nazi accomplices or as perpetrators. Stefan's statement that *"Our children also grew up knowing what the Holocaust is and what the family on my wife's side suffered"* makes clear that he also wants the next generation to concentrate on Irit's family history and to ignore his own.

Let us consider Stefan's own experiences as a soldier in wartime. While still a student, he served as a medic during the Suez Crisis. He served as a physician in Israel's subsequent wars.

He was called up in 1967 during the Six Day War and spent several months as physician to a tank battalion. During that time, he did not see his family. Stefan views that war from the perspective of his experiences in the Yom Kippur War: *"In the Six Day War it wasn't so bad for me. We didn't have many dead or wounded."* Stefan served in the 1973 war, which was very traumatic for Israel, after his return from England. He talked about his work in a team of physicians in a field hospital in Sinai:

*"The whole time, day and night, the helicopters came from the front filled with seriously wounded men that were brought down to us. In a big hall, where one had to decide quickly, where they would be treated, where operated on. And that was very hard and very intense, very hard, veery heroic (2) with wonderful colleagues."*

Stefan said how he had to summon all his skills. He experienced the many operations, the treatment of very serious wounds, and his encounter with so

many dead as a great professional challenge. The interview made very clear that being a physician is central to his identity. As a nurse, Irit shares his vocation.

We assume that their marriage provides shelter to both Irit and Stefan. Entering Stefan's family system helped Irit separate from her own family. She bound herself to a man who had not experienced an equivalent traumatization. Unlike her sister, Irit survived the persecution, because her looks did not correspond to any Jewish stereotype. It is possible that Irit feels - perhaps unconsciously - that she is safe in the Stern family, with its partly Christian background. Something else that binds Irit to her husband is that they both felt out of place in Israel. As children, both were outsiders in Israel. They were unable to share their horizons of experience with their peers.

Stefan can approach the theme of Nazi persecution through his wife, but he has blocked out parts of his own family history. By playing down the intensity of the conflict between the two families he tries to reconcile the two sides, the non-Jewish and the Jewish, that of his mother and that of his wife.

### *The Grandson: Living with separate family histories*

When the German interviewer asked Samuel<sup>65</sup> to tell her about his family history and then his own life story, he asked: *"What side, the Holocaust side or the-*". At the very start, Samuel already distinguished between the two sides of his family - the Holocaust side and the other side, which does not have a name. When the interviewer said *"both sides"*, he decided as follows: *"My grandparents on my father's side, yes?"* He began with his father's side and talked briefly about the Sterns, his grandfather's *"aristocratic family"* in Vienna. He said his grandmother came from a small town near Vienna. The entire passage about this side of the family focused on the theme of his *"grandfather's career"*. This sequence, which is textually separate from the account of the *"Holocaust side"*, he rounded off by saying: *"So that is that part of the family. That is my father's side"*. Then he began to talk about the other side, clearly demarcated from the first: *"my mother's side of the family"*. Samuel then presented that family in a remarkably similar way. He recounted many more details, talked about twice as much about this part of the family, but the structure of his text is very similar. Here too, the sort of text Samuel chose to use is the report. Here too, he first described the geographical background of his mother's family of origin and then the various stages of her persecution; they were the main theme in his presentation of this part of the family. He concentrated on how his mother was saved from the camp and the murder of her sister Lea. Samuel said his grandmother and her daughters were

---

65 Compare the detailed case study in Schade (1995). The interview was conducted by Bettina Völter in English in 1994.

in the Ebensee concentration camp and that his mother's sister, his aunt *"was killed during the last Aktion in the camp"*. He did not, however, specify where his paternal grandmother was from, saying she came from somewhere near Vienna. In fact, her hometown is south of Linz and some 150 kilometres from Vienna. Thereby he performed a geographical separation of the two sides of the family. Also, Samuel and Irit presented part of her family history in quite different ways. Samuel "healed", so to speak, the separation trauma of his mother, who after the liberation waited in vain for her mother to come and fetch her: *"She ((the mother)) was taken to this German's family and later on reunited with my grandmother, who was by that time already a partisan in the forest. Together they more or less ended the war. I mean they were never separated. That is what I know, my grandmother escaped from Ebensee and she became a partisan"*.

This shows that Samuel tries in his fantasy to bring together his grandmother and his mother. He introduced his grandmother as a partisan, thus stressing that she put up a fight and did not suffer passively. He is himself unsure whether his information is correct; it is based on stories he heard in the family. He said his grandmother hardly ever talked about it and his mother told her stories from her perspective as a child at the time: *"What she recalls from the war, are more the impressions of a child"*. Perhaps in order to shield her son from her trauma, Irit did not tell Samuel what she told us about her separation from her mother. Samuel experiences his grandmother Sarah as a good and kind woman, who is *"full of love."* He finds it hard to reconcile that with the hurt his mother suffered. Samuel stressed again and again that his mother only told him fragments and that he put the rest of the story together himself, in his fantasy. Samuel ended this part of his family history with the comment: *"That is my family"*. The remarkably structured presentation and the clear separation of the two sides indicates, on the one hand, that he wanted to be fair to both and to present them in an objective, balanced manner, without voicing his own opinions. On the other hand, it marks his effort to keep the two sides apart. This distanced and controlled presentation presumably derived in part from Samuel's wish to maintain a certain distance from his non-Jewish German interviewer. The analysis of the interview made clear, however, that it was also an expression of the way he deals with his threatening family past.

Apart from the clear division of the two sides of his family, Samuel also divided the story of his life from the history of his family. After his final remarks on his family history, he did not carry on and recount his own life. He had to be asked again to do so by the interviewer. Samuel replied: *"okay, my life story is very short"*. The account of his life he then delivered was very brief. At the time of the interview, Samuel was twenty-seven years old, studying medicine, and about to take his final exams. The transcript of the interview is 103 pages long; the text of his life story in the main narration takes up

just half a page. He merely listed biographical data, concentrating on his father's career and his own. In this brief report he mentioned neither his mother nor any other members of the family. He ended after a few minutes with the sober remark: *"That is my life story"*. While his account of his family history (3 pages) contains a number of details, Samuel's own life seems to fade into insignificance against that background. It is also striking that the themes he addressed in his self-presentation resemble those of his account of his father's family, focusing on his education and profession. He consciously identifies with the career of his father and grandfather. The extent to which he also identifies with his mother's past as a victim of persecution became clear later in the interview.

First let us consider his life history more closely. Samuel was born in 1967 in Israel. His brother Dan is three years older. Their grandmother Martha looked after them during the day. When Samuel was three, his life underwent a great change, when he, his parents and his brother went to live in England. Samuel talked positively about that period. His earliest childhood memory is remarkable. He remembers being stung by a bee in England when he was three and being taken very quickly into the house by his brother Dan. This first memory is about a danger, from which he is "rescued" by a sibling. While not wishing to accord too much significance to this memory, we do want to mention the association it called to our minds of his mother's persecution as a child.

Martha Stern visited them several times in England. Samuel's comments about his grandmother indicate that their relationship was affected by the separation while they were in England and that, when they returned to Israel to live in the house of his father's parents, the relationship did not really recover. Samuel can only recall a few outings with his grandmother and he talks about her in a distanced manner. He only hints at the problem of her emphatically Austrian way of life and mainly resolute resistance to Israel.

In terms of language, however, Samuel is still very bound to his grandmother, since in the first three years of his life, his first and only language was German. He then learned English in England, where he also started school. He found it hard to learn Hebrew when he returned to Israel. He learned Hebrew with the help of his grandmother tongue: *"I used to ask how do you say it in grandmother's language and how do you say it in Hebrew. Because most of the language I knew was German and I had to learn Hebrew."*

Let us recall again the important role language plays in the family: Martha still clings to her mother tongue many decades after her emigration. Her son Stefan felt out of place in Israel as a child because he had been brought up in German; when he was nine, he was confronted by another language barrier - this time in Finland. Irit was not only confronted by a foreign language, which carried menace with it, during the years of persecution, she also had to learn a new language when she emigrated in 1948. In addition, she then had

to adopt the language of her erstwhile persecutors in order to be accepted by her mother-in-law. Difficulties with socialization in language recur in Samuel's life history. Like his father, he first learnt German in Israel, then he went to school in England and returned to his home country, which had become alien to him, when he was seven, unable to speak the language. What or who in this labile configuration of linguistic and perhaps also collective belonging could offer Samuel help in finding himself?

Samuel found someone he could identify with in his paternal grandfather. Especially after his return to Israel, he developed a close relationship with Nathan Stern that was based on respect and admiration. The issue of language also played a role in this relationship. Samuel recalled that as a child he used to help his "Opa" with scientific translations. Samuel felt their joint "scientific" efforts marked a close bond with his grandfather, who respected Samuel even as a child and acknowledged his abilities. Samuel's relationship to his grandfather Nathan was an important stimulus to his intellectual and professional development.

Samuel left high school before the end of his last year to go with his parents and younger brother Eli (born in 1974) to England for a year. In 1986, he began his military service in Israel as a medic. The political climate in Israel was strongly influenced by the Lebanon War, the mounting criticism of the Israeli invasion and the discourse on Israel's 'strengths and weaknesses'. When the Palestinian uprising or Intifada began in December 1987, Samuel, who was in the reserve, was drafted and served in the Gaza Strip. Like many others of his generation, he suffered a serious crisis of orientation (cf. Bar-On 1992b). Quite unlike their fathers' generation, these young men could not simply identify with the military operations. Samuel saw himself as both persecuted and a persecutor. His parents were actively committed to the peace movement, seeking reconciliation with the Palestinians. Samuel experienced his military service against this horizon of his parents' experiences. Like other children and grandchildren of Holocaust survivors (cf. the Goldstern family, Chapter 2.3), Samuel compared Israel's armed forces to the Nazis. He adopted the perspective of the Palestinians, in particular that of Palestinian children, and saw parallels to the persecution his mother had suffered. These two themes came up repeatedly in conversations with his mother:

*"Every time we talk about the Palestinians it comes up, because there is a deep fear of being a conquering nation, having people under your control. It has a lot of connotations for her with the Second World War. And whenever I serve in the territories, I have that in the back of my mind (2) that is thanks to her."*

Taking the perspective of the Palestinians led to a moral dilemma. On the one hand, Samuel believed these military efforts were necessary in order to defend Israel; on the other hand, he did not want to face unspoken accusations

from his mother. That is, he was frightened of acting - in her eyes - like a Nazi. Samuel found it particularly hard to reconcile nightly patrols and enforcing curfews with his conscience.

Palestinian children would often wake up in terror, as soldiers of the Israeli Defence Forces (IDF) searched their houses. Samuel identified strongly with these persecuted children:

*"The impact on the children is for me the most tragic thing that can happen. I always think that I'm doing something terrible to these children and I'm doing something that probably can't ever fix, there is no way that these children would learn to live with me in a peaceful and respecting way if they see me do this to their brother or to their father ... It's something very frightening to me."*

Samuel was frightened the children might respond violently in self-defence and frightened of how he might react. He talked about stones being thrown at Israeli soldiers, stones that could kill. He said children once threw a refrigerator at his commanding officer and almost killed him. But he also ended that story with the comment: *"But (3) you know that (3) they are children"*. He then went on to talk about the persecution of children in the Holocaust. He mentioned his mother's fear of German soldiers, saying *"she gives me some deep feeling about what we are actually doing"*. As he continued to talk, it became clear that the Palestinian children made him think of his mother's murdered sisters. He also repeatedly made slips of the tongue, describing his aunt, his mother Irit's older sister, as his own sister. For example:

Interviewer: "Did your mother tell you about her sister?"

Samuel: "She didn't tell me no I don't know about my sister much"

A little later, when talking about how his mother was saved from the concentration camp, he again referred to her sister as his own: *"He could only save my mother he couldn't save my sister because she didn't have the right colour of hair and the right colour of eyes and he couldn't pass her off as an Aryan."*

By referring to his mother's sister as his own, he also adopted, unconsciously, his mother's perspective and assumed her moral conflicts. She survived because she, unlike her sister, had the *"right color(s)"*. Samuel sees his mother's murdered sisters as his sisters, as becomes clear at other points in the interview. He conceives the sequence of generations as if his mother were the mother of her own siblings. He said, for example, when discussing the killing of his mother's youngest sister: *"When my mother lost her smallest daughter"*. This confusion of the intergenerational relationships and thereby the blurring of generational boundaries is evident throughout the entire sequence on the persecution of his mother's family.

Samuel is hardly able to put together the various events into a chronology, as he himself realized in the course of the interview. In his fantasy, his

grandmother was with his mother hiding on the farm. He realizes there might well be a disparity between the stories of persecution his family told him and the way he visualizes them: *"Everything that they tell you, brings up a picture but it is not a real picture, you connect something that you hear with a picture that you make up, but it is never a true one."*

Samuel also described how these fantasy images changed with time. This is how he imagines the killing of his great-grandmother and his mother's youngest sister today: *"Basically I see an old woman running with a child in her hands and being shot down. That's what I see I don't see much more than that."*

The interviewer asked him "scenic memory" questions that helped him to draw hesitantly closer to his fantasy images:

Samuel: 'Oh' (6) basically it's a village scenery and (7) don't know if it=has=any=meaning but I can see a cart, I see in the scene a cart, but=it=has=no=horse=there, it's just a=cart. And I see them running

Interviewer: So you see that, village scenery

Samuel: and: my grandmother and my-, and=the=baby"

Here too Samuel used the possessive 'my' - evidently seeing the baby as his own sister. The interviewer asks him about the image of the cart without a horse, Samuel answered: *"It used to be a bit different, it used to be my mother, her daughter, eh sister: and my, grandmother sitting in the cart, no horses and no rider and my grandmother trying to get to the cart, and being shot, used to be that. Today, it's much less dramatic. It's just a cart that's there with no horses and no driver', and that's it. Today when I imagine the scene I just imagine my grandmother with the baby in her arms being shot with the cart in a scenery.... because it's a fantasy, I just changed it, that's all"* (underlining by the author)

Earlier Samuel saw the grandmother, that is his great-grandmother, running to the cart and saw how she was shot. Now he imagines how she is shot with the baby on her arm. Samuel described this fantasy, which is closer to reality, as less dramatic, but he still doubts the reality content of this image: *"There's no basis for that fantasy. I mean even today, there is no real ground for it. I don't know why I never asked my mother what the real situation looked liked."*

Samuel said he thought his mother would tell him but that it would be "inappropriate" to ask. The statement, *"I think it's my problem it's not her problem,"* implies that he not only wants to protect his mother but also protect himself from the dangers that would come with adopting her perspective:

*"I just, don't want to bring up this, specific, situation with my mother. I don't know how it affected her, when she was aware of the fact that her grandmother got, shot down before her eyes. I mean, for a child it must be a*

*terrible experience, and: I'm not sure if- 'how it affected her and: I'm not sure I want to find out how it affected her' ((underlined by the author))*

Is Samuel only frightened of realizing the extent of his mother's multiple traumatization, or does he also want to protect himself? Reflecting on such traumatization bears a close relationship to the serious moral conflicts he experienced as a soldier in the occupied territories. Just how seriously these moral conflicts trouble him became clear in his extensive account of the half year he spent in India. In long talks with a Buddhist master he sought answers to questions of existential importance:

*"I asked him a few questions concerning general ethics .... People are getting killed and you, one person is serving in the army and he has a duty to defend his country I mean (4) what can one do, when he's in a situation like that? So (4) what they have taught me is, that there's a different place to look at every situation and it's also to do with medical ethics and also war-time ethics they gave me some ideas (3)."*

While a medical student in a hospital, Samuel witnessed the death of his grandfather Nathan Stern. He talked about it soberly - like a physician. Only at the end of the interview did he reveal what his death meant for him. He then talked about the death of his grandmother Sarah Planka, who died just one week later. Samuel thinks the two deaths are related: *"She liked him very much ... there is a connection, deep down inside. It is still strange for me, a week later, exactly the seven days of Shiva, the seven days of mourning"*

At no other point in the interview did Samuel talk so emotionally about someone close to him: "She was a wonderful woman, very loving, she had all the love in the world, TOTALLY EMOTIONAL, EXACTLY THE OPPOSITE of my grandfather."



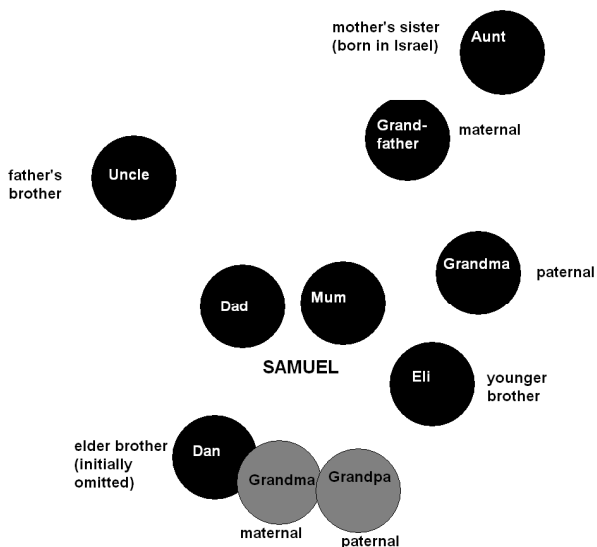

**Figure 3: Samuel's family sculpture**

During the family sculpture exercise, Samuel positioned Sarah and Nathan very close together, sticking their adhesive circles right on top of each other. In the process, he asked Sarah whether there was any connection between her death and that of his grandfather Nathan. He then talked about the days immediately after the grandfather died:

*"When he died, I got very very sick, I don't know why, probably some- (5) and (7) suddenly it was something, nobody could understand I mean I got a very high fever. It passed, two days after that I think it's some-, it has something to do with my emotional state at the same time."*

Samuel tried to split off his mourning and acted it out psychosomatically. He had hardly had time to mourn his grandfather when his grandmother died: *"I just found it quite impossible to deal with these two deaths and the same time. Both of them were very close to me and I love them very much both of them."* His fantasy, that Sarah's death and Nathan's death were connected, signifies an imagined union between the two sides of his family - represented by the one grandparent on each side to whom he was close, whether intellectually or

emotionally. He links the intellectual Jewish grandfather from an "aristocratic family" in Vienna and the emotional grandmother who had survived the Holocaust.

At the beginning of the interview, Samuel attempted to keep the two sides of his family apart, but here he unites these two grandparents. While his father sees the family as composed of pieces like a puzzle, Samuel has two separate pictures, one of each side of his family: the Holocaust side and the other side, to which he ascribes no distinguishing attribute. With this symbolic merging in the family sculpture of grandfather Nathan and grandmother Sarah, Samuel excluded from the ensemble both his grandmother Martha and his maternal grandfather, who had been absent from the family during the years of persecution.

In summary, we can infer that Samuel feels as though he falls between two stools, both between the two sides of his family and within Israeli society, where he is both a citizen whose duty it was to serve as a soldier and the son of a survivor. While he can formulate the differences in his perspectives on Israeli policy in the occupied territories, he - like his parents - avoids confronting the different perspectives and pasts within his family.

Facing these divergent family pasts is still too threatening for the Stern family. Samuel's father, Stefan, declined to take part in a family interview.

## 9. The Kubiak/Grünwald family dialogue: blocking out the theme of migration from Israel to East Germany

Maria Nooke in cooperation with Christine Müller

### *Preliminary Remarks*

It was on the initiative of the grandmother Rahel Kubiak that we came into contact with this family<sup>66</sup>. In response to our advertisement in a Jewish Community Centre newspaper, she offered to take part in an interview with us. Rahel introduced herself as a survivor of the Gross Rosen concentration camp. At the age of thirteen, in 1941, she was deported to a forced-labour camp that was made a part of the Gross Rosen concentration camp in 1944. Rahel showed a great deal of interest in being interviewed. She asked us to make a copy of the tapes of her interview and later gave them to her children, grandchildren and some of her friends on special occasions. Rahel wants her relatives and friends to see her as a survivor of the Shoah and to become familiar with the history of the persecution she suffered as a child. One of the ways that her two sons and her non-Jewish second husband express their attachment to Rahel is by visibly wearing a Star of David around their necks on which she has had her inmate number engraved.

Right at the beginning of our first meeting with her, Rahel shared the psychological problems of the persecution she suffered with us. After we had exchanged hellos, she started by complaining of sleeping problems. She said that because of her regular headaches she needed a lot of fresh air, adding that she had to keep her bedroom window closed because she found the noises it let in from the brothel across the road extremely disturbing. She said that she could not stand the car exhaust, either. Rahel made it clear that she found it very hard to bear the idea that the noise of the brothel and the exhaust could penetrate her privacy. Already at this point in the interview, in her description she had touched on two themes that play a central role in the persecution in her past: "sexuality" and "exhaust fumes". Throughout her life story there are sequences revolving around the theme of "sexuality" that suggest that Rahel witnessed others being subjected to sexual violence and may have been exposed to it herself. Another of the themes in the interview that refers to Ra-

---

66 Rahel Kubiak was interviewed twice by Bettina Völter and Maria Nooke in 1994.

hel's most traumatic experience is her violent separation from her mother and the murder of her parents. She only found out that they had been murdered, when an uncle told her after the liberation. Rahel is convinced that her parents were deported to Treblinka and murdered there. The historical research she undertook revealed that the Nazis and their accomplices used exhaust fumes from diesel engines to operate the gas chambers there (cf. Hilberg 1994, p. 941).

We assume that noises from the brothel across the road and car exhaust entering her bedroom presumably trigger Rahel's traumas linked to these themes and reactivate her fears. After the interview had been going on for about five hours, during which time Rahel had focused on the period when she was persecuted, her sons joined us. Rahel had asked them both to take part in the interview. We were amazed to discover from her younger son that the family had lived in Israel for thirteen years (from 1949 to 1961). Her sons often speak Hebrew among themselves and with their mother to this day. This raises the question of why Rahel had not even hinted at this phase of her life up to this point in the interview. Again almost by coincidence, it emerged only in the second interview that the family had also lived in East Germany for many years. On the basis of the first interview, we had assumed that the family had emigrated from Israel to West Germany.

Rahel's need to discuss only certain parts of her life defined the way she presented herself in the interview. She spoke with confidence about her life and confined herself almost entirely to her experiences before the liberation. At the beginning of the interview, she took control of its course and increasingly put the interviewers on the defensive. It was important to her to know, what would happen to the interview, what purpose it served, what would be published. When she was told that the names of the interviewees would be changed to protect their anonymity, she reacted angrily and stressed that she was not afraid of her story being public knowledge. She took us to task, asking: *"Am I supposed to be ashamed, have I done something wrong?"* Rahel made an effort to get straight what she wanted to communicate in the interview, namely: how much her life has been shaped by the persecution and the enormous suffering she has endured due to the aftermath of the Shoah. Only once it was clear to her that we were genuinely interested in the persecution in her past could we ask the initial question; only then did Rahel begin to tell her life story. In telling it, she presented herself primarily as a survivor with the image: "I was a little inexperienced child". In her main narration, she repeatedly argued that she was just a little child at the time, who did not know what was happening to her, could not understand it and was still so inexperienced. The analysis of the family dialogue showed that it is very important to Rahel that her sons see her as a child survivor and not so much as a mother who in

her adult life decided when and where the family would emigrate. But before we turn to this part of the family history, let us first focus on the traumatic experiences Rahel went through as a child.

*The grandmother Rahel: "I lived until the age of twelve and since the age of twelve I have existed"*

Rahel was born in 1927, the third daughter of a religious Jewish family in Polish Czestochowa. Before World War II, 28,486 Jews lived here, accounting for 30% of the population (Gilbert 1995, p. 32, Map 28). Living according to Jewish traditions shaped her family life. The family had close contact to its numerous relatives and was respected and well-integrated into its social environment. As the youngest child, Rahel enjoyed a special position within the family. She experienced the tender, loving care lavished on her by her mother, but also found her parents strict, especially her very authoritarian father. Rahel was a very lively child who inquisitively explored the world around her and claimed it as her own. She went to a Polish school and learned Yiddish at Hebrew school in the afternoons. As a young girl, she was curious about the non-Jewish milieu. Without her parents' knowledge, she sat in on Catholic religion lessons. She regularly disregarded the rules and did not shy away from breaking taboos, either. Rahel told one story that displayed her rebellious behaviour towards the traditions kept by her parents. When she was eleven years old, she arranged to go to the cinema with Christian boys on the Shabbat. When her father realized what she was up to, Rahel denied it to his face. To punish her for her lie, her father tied her to the table in front of her friends. *"If he had beaten me, I might have done it again. I would have thought, it'll pass, you won't feel it tomorrow. But no, the boys saw it, too. ((softly)) That was too much."* Being humiliated by her father this way hurt her deeply.

Throughout the stories of her childhood, Rahel linked rebelling against her parents with not observing religious practices. This begs the question of what role religion played in her later life.

As well as its authoritarian strictness, Rahel also experienced a sense of security in her family, who were particularly important to her in difficult situations. She remembers a pogrom that she experienced as a nine-year-old girl before World War II, in which buildings were plundered. Her memory of this event is not dominated by feelings of fear and menace, but by the experience of her mother protecting her and making her feel safe. This experience took on existential significance for her when the persecution began in Czestochowa in September 1939. In the interview, Rahel began her life story with

the most decisive event in her life, which occurred at this time: *"Yes and like I said the war started when I was not quite twelve"*.

This statement marks the crucial biographical turning point that separates the past before the persecution from the persecution itself and her life afterwards. Rahel finds it hard to talk about this traumatic experience, and only when asked did she give details of the first brutal killing operations committed by the German *Wehrmacht* on the Jewish population. Her parents were away on a trip at that time and Rahel was being looked after by an aunt. Her sisters were not at home either. Rahel was shocked at the rough and violent behaviour of soldiers who had given her candy at an earlier time. She and her aunt and cousin were driven out of the house and marched off to a schoolyard with many others. There, they had to stand with their hands in the air for hours in the scorching heat and watch, as the Germans inhumanly mistreated their acquaintances and relatives. She witnessed a child being brutally murdered:

*"I LOOK (2) our building's on fire. (2) ... And a soldier has the mother - three children she was holding two children BY THE HANDS and the third child was running behind her. I don't know how old it was but anyway ((takes a deep breath)) (2) and I kn- KNEW (1) the the uh man (1) ((softly, shakily)) Oh man you can't you mustn't say it. He took the child and threw it into this burning building."*

Women and men were separated from one another. Rahel had to watch, as the men were marched off and shot<sup>67</sup>:

*"They picked out ten men and marched them off to this paper factory. (2) Shot them. (1) Ten new other men (2) brought them, those who had been shot, and were shot THERE. (2) And that's how it went. Always ten men. (1) Suddenly we see how they're leading (1) my cousin, too (2) and (2) then (1) ((shakily, softly)) hands up (3) hands up (1) and it was such a great sunny day, you know?"*

Rahel was terribly afraid that something might happen to her and that her parents would not be able to find her. They were not allowed to leave town until evening. She and her aunt took shelter in the home of some relatives. Rahel could not sleep the whole night for fear of further acts of violence, uncertainty about where her sisters were and despair at what had happened to her cousin. The next day, when things had calmed down, Rahel went with her aunt to look for her cousin:

---

67 On 3 September 1939, 180 Jews were shot in Czestochowa (Gilbert, 1988 p. 33, Map 29).

*"Come on now first let's go over to the ditches and see if the boy's still alive. And he really was still alive. He had a penetration wound and had groped his way out of there. Any number of corpses had been lying on top of him. (1) And to get some air, he couldn't walk, and then we dug him out."*

They brought her wounded cousin to relatives and waited in desperation for the return of the other family members. It was in this horrific situation that Rahel experienced the loss of safeness and protection for the first time. She felt helplessly at the mercy of the violence and had to overcome her fear alone. She was very relieved when her sisters were found and her parents returned home soon after. Her mother's loving care in particular helped her over the difficult time that followed. When the Czestochowa ghetto was established in 1940, the family had to move. Food supplies were extremely scarce. Rahel undertook a number of risky forays for food outside the ghetto. She was frightened especially by the many shots that fell around her. Rahel remembers how lovingly her mother tried to calm her down: *"And when they were shooting, the Germans ((takes a deep breath)) (2) I couldn't sleep for fright and for fear. Then she said: 'come to me'. And she sort of wrapped me up in herself in herself."*

In late 1940, her father brought her illegally to her elder sister in Upper Silesia, because food supplies were somewhat better there. That night was the last time Rahel saw her father. Her mother managed a few visits to her two daughters. During one of these visits, Rahel was discovered during a raid and deported. This experience was the first story Rahel told in the interview and thus is presumably of particular biographical significance. For Rahel, it is linked with her separation from her mother. She was at home alone with her mother, her sister had gone out, when a Gentile neighbour came to warn them:

*"Hide your daughter (1) 'there's a raid' and there were never raids on Sundays. And my mother, she wasn't thinking of me. She said: 'my daughter's just gone out to the Community Centre' (1). No she said, hide the little one! And in her agitation, my mother put me in bed and covered me up. But the women saw her do it ... The Germans came IN (2) and went straight (2) to this bed where I was tucked up, went in-', that was Dece- January. And 'cause I was hiding I wasn't allowed to wear a coat. And just the way I was in the apartment, I was deported."*

Whereas at the beginning of the war, Rahel had endured powerlessness and being at the mercy of the Nazis when her parents were not there, now she experienced her mother having to watch powerlessly and being unable to either protect her or come to her aid. For Rahel, the trauma of separation from her mother is linked to a loss of warmth and safeness and all sense of security.

Keilson (1979) emphasizes in his concept of sequential traumatization<sup>68</sup> the particular significance in the persecution of children of being separated from their mother and indicates the psychological after-effects that result from this separation. Rahel is still suffering today under the loss of her mother whom she has idealized ever since.

When the *Wehrmacht* soldiers entered her bedroom, Rahel experienced herself as being completely at their mercy. We may well ask ourselves whether her present-day unease regarding her bedroom and the problems that she has sleeping are an after-effect of this experience of persecution.

Rahel was taken to an assembly camp. On one occasion, when SS guards were putting inmates on a transport, she saw them set dogs on a girl who resisted. Rachel had to stand by and watch as the dogs tore the girl to pieces. We did not hear the details of this experience from Rahel, but rather from her son Reinhard, who finds this particular experience of his mother's extremely threatening. Rahel only mentioned her fear of dogs, which she attributes to this experience.

The transport took them to a forced-labour camp set up by the Schmelt organization<sup>69</sup>. Here, Rahel had to do hard labour at a spinning mill. She felt very oppressed by the separation from her family and the uncertainty of what would happen to her. She tried to take her own life on two occasions. It was only through the support and care of the older girls that she regained her resolve to live. In March 1944, the camp was made part of the Gross Rosen concentration camp, which resulted in conditions becoming extremely harsher. Rahel, however, dates this event back to 6 February 1942, two years earlier, and links it to a selection procedure that she experienced<sup>70</sup>. This is the only exact date in the interview, that relates to the time she spent in the camp, and we can assume that it has special significance. But why does Rahel associate a different date with the forced-labour camp becoming part of the con-

---

68 Keilson differentiates between three traumatic sequences in the traumatization of children by the National Socialist persecution. The transition between the first and second sequence, which is linked to a direct threat to their lives, is generally marked by separation from their mother. The third sequence is their return into another world after the liberation. This phase often led to an intensification of the traumas that the child had suffered. This also becomes clear in Rahel's case later on.

69 SS-Oberführer Albrecht Schmelt was "Special Commissioner for Alien Labor in Upper Silesia" from 1940 to 1944. He organized Jewish forced labor (cf. Konieczny 1994, p. 8 and 1983, p. 97ff.). At the end of November 1940, an assembly camp was set up in the new Jewish school in Sosnowitz for Jews who had evaded registration (Konieczny 1983, p. 99). Presumably Rahel was picked up and deported in this connection.

70 In connection with the disbanding of the Schmelt organization and with the forced-labor camp becoming part of the Gross Rosen concentration camp, the SS guards selected some inmates for the gas chamber (Konieczny 1983, p. 106) and some for transports to Auschwitz (Konieczny, 1994, p. 13).



centration camp? Possibly she is merging two decisive events that she experienced in the camp in her story. Let us examine her narrative in more detail. In February 1942, Rahel was fifteen years old. She told us that the girls were allowed to shower for the first time on that day. Afterwards, they were made to go to a barrack and had to take all their clothes off and stand there naked. Rahel recalled:

*"Yeah when my name was called (1) we had to go past this row of men there. (1) The SS men looked which ones they wanted. I went in (2) then uh to - the camp commander sat in the room (=there) (1) and a man in a white coat. Well we assumed, that's a doctor. ((takes a deep breath)) (1) There was like a circle actually drawn with chalk. We had to step into the circle and turn around. (1) And he evaluated whether we were suitable or we were not suitable."*

Women from other concentration camps run by the Schmelt organization describe being selected in a similar procedure when forced-labour camps were being dissolved in 1944 (Konieczny 1994, p. 13). But Rahel's words that *"the SS men looked which ones they wanted"* as well as other hints in the text call to mind the association that Rahel may be hinting at experiences of sexual violence here. It is striking that Rahel does not talk about what she was selected for and what the consequences were. We only find out that the working conditions became more extreme and that towards the end of the war she was forced to dig trenches. A few weeks before the liberation, Rahel was brutally beaten by a female SS guard on the way to work for disobeying the ban on talking. This left her blind in one eye.

On 9 May 1945, Rahel lived through the liberation of the camp by the Red Army. Speechless with happiness at first, these women then had to endure terrible things. Rahel recounted:

*"Well then the uh, the second battle started, you know? (1) with hiding and and and and and rapes and ah- ((hums and haws soundlessly)) (4) You just can't talk about that again. You can't go through that. And you can't share the feelings of people who survive that. WHY, why can you survive all that!"*

This sequence permits the assumption that Rahel was also one of their victims, but when asked directly she denied this. Possibly she still finds it too hard to break through the taboo surrounding this theme. And yet throughout the interview, there are indications of sexual experiences characterized by a feeling of powerlessness and of being at the mercy of the other person. She also speaks of her wedding night in a way that makes it sound like a rape.

After she was liberated, Rahel went back to her hometown. There she found out that her parents and her sisters had been murdered. She felt alone and in despair. It was in this situation that she met an acquaintance of her family. Like her, Aaron Grünwald was the only survivor of his immediate family. After a certain amount of hesitation, Rahel agreed to marry him. She fell pregnant soon after and her eldest son Dietrich was born in 1946 in a Displaced Persons camp in Germany. In the beginning, she had ambivalent feelings towards her son. On the one hand, he gave his eighteen-year-old mother a sense of self again and a meaning in life: *"Somehow I woke up then ... that was my heart and that was something of mine and that was me!"* But on the other hand, Rahel suffered from serious depression during this time and lost her faith in God: *"At that time I was in a phase where I wanted to renounce myself, where I had renounced myself (honestly), you know? Where I'd said there is no God (I) If a God allowed that then he's not the one responsible for me."*

In 1947, the young family went to Brussels illegally where they found an aunt and uncle of Aaron's. These relatives were Communists and inspired Rahel with enthusiasm for Communist ideas. In her search for security and hope for the future, they offered her something new that she could identify with. In the summer of 1948, she bore twins, Reinhard and Christoph. Just before they were about to leave for Israel, the twins became ill and Christoph died of meningitis at the age of six months. Rahel now devoted all her attention to Reinhard's recovery, who was strong enough to get over the illness, and to her new life in Israel. There, she became a member of the Communist Party.

Let us look now at the further course Rahel's life takes, which she herself told us hardly anything about. In response to the interviewer's questions, she spoke hesitantly about why she had left Israel with her family after having lived there for thirteen years. She said that, as a member of the Communist Party, she had trouble in Israel and had to move to East Germany as a result. She related the trouble that she had to the Eichmann trial. She said that, after she had published a statement in a newspaper protesting against Eichmann's attorney for the defence, Dr. Robert Servatius, being paid although he had claimed that children had not been murdered, she was arrested. (In fact, he made no such claim). To escape a six-year prison sentence that was hanging over her head, she said that she had followed the party's advice and, with its help, had left the country and gone with her family to the *"democratic Germany"*. This depiction begs several questions. It is hardly conceivable that this protest could have led to such a heavy prison sentence. The research we did in Israeli archives and newspapers turned up no evidence of the conflict Rahel described. We must ask ourselves what connection there could be be-

tween Rahel, the Eichmann trial and East Germany. With relations to Israel having been extremely strained since the early fifties, East Germany was very interested in the Eichmann trial. The state's self-conception as the "anti-fascist German state", as representing the "good" Germany in contrast to West Germany, which was seen as the successor state to the Nazi regime, also played a role in connection with the Eichmann trial (cf. Segev 1995, p. 450; Wolffsohn 1996, p. 27ff). East Germany tried to influence the course of the trial<sup>71</sup> by presenting explosive documents on Hans Globke, one of the closest advisors to the first (West) German Chancellor Konrad Adenauer, who had been one of the architects of the restitution agreement (Segev, p. 450). During the Nazi period, Globke played a major role in drawing up the Nuremberg laws. East Germany's objective was to make a joint effort with the rest of the Eastern bloc to become directly involved in the Eichmann trial for the purpose of denouncing West Germany to the international community, and by doing so, both isolating it and exonerating itself. This aim must also be seen in the context of the political situation of the time, manifested in the building of the Berlin Wall - the "anti-fascist rampart barrier" - in August of the same year. East Germany's plan was thus to use the Eichmann trial to legitimize this move of political separation. It is therefore safe to assume that the East German regime had a real interest in critics of the Eichman trial, which Rahel was, according to her statement. However, no evidence of Rahel's activities is to be found in any of the East German sources on the Eichmann trial that are currently accessible. Thus, her reasons for moving to East Germany in November 1961 are unclear. It is possible that her portrayal of her motives is a screen story to conceal the real reasons for her emigration. What other reasons could she have had for what she describes as her illegal move to East Germany? We discovered from her sons that Rahel had held a high position in the party, had had good contacts to the ruling party of the time and had played an important role in preparing for the Israeli elections of autumn 1961. After the Eichmann trial and these elections, which were preceded by a government crisis, the Israeli public was rocked by a spy scandal coming to light (Naor 1996, p. 326-330). In the wake of this affair, Israeli security forces arrested the spies they had exposed, who were accused of contacts to a foreign intelligence service and to Arab states, and were given sentences of five to ten years in prison. Whether it is possible that Rahel had any connection to these incidents remains unclear. However, it is certainly safe to assume that there were pressing reasons for her migration. This part of her life history is one of the phases that Rahel concealed.

---

71 Analysis of the Eichmann trial, no date, SAPMO ZPA, Ulbricht estate, NL 182/1121.

In the interview, Rahel said nothing of all the problems in the family right after the emigration to East Germany, either. We discovered from her sons, that she had had a heart attack shortly after the family moved, that there were problems in the marriage, that her husband left her and moved to West Germany and that her eldest son reacted by falling into a state of active refusal to the point where Rahel was prepared to send him to boarding school.

Her political convictions as a Communist and the fact that she was a recognized "victim of fascism" remained ways in which she could identify with the new society. In material terms, Rahel was relatively well-off in East Germany. When they arrived in the country, the family was met by a government delegation, and to start with, they lived in government accommodation. Because she was a recognized victim of Nazi persecution, she was given special support in matters of everyday life. Rahel had direct contact to high state and party functionaries until late into the eighties, and she repeatedly turned to them for help. But Rahel found it very hard to bear the discrimination of not being placed on an equal footing with members of the Resistance<sup>72</sup>. The move to East Germany was not something she experienced as the fulfilment of her political ideals. She was loyal to the new state and accepted its political course but never joined the SED<sup>73</sup>.

Her eldest son married in the mid-sixties, but his marriage broke up shortly afterwards, even before Rahel's eldest grandson, Stefan, was born. In 1970, Dietrich married a second time, shortly after his brother Reinhard. Reinhard's eldest daughter Hannah was born in 1970, and Dietrich's second son Jens was born two years later.

Rahel's husband and the father of her sons, Aaron, died in a car accident in Poland in 1975. Rahel remarried in the same year. Her non-Jewish second husband, Karl Kubiak, was born in 1930 and was a member of the Nazi youth organization, the Hitler Youth. The significance this choice of partner had for her family did not emerge. But it is striking that a year after Rahel's marriage, her sons applied to leave East Germany<sup>74</sup> and moved to West Germany with

---

72 In East Germany, recognized victims of Nazi persecution and members of the Resistance were entitled to special health care and other benefits as well as an honorary pension, but members of the Resistance received more money. (Zimmermann, H. et al 1985 Vol. 2; p. 1484).

73 The German Socialist Unity Party, the SED, was the ruling party in East Germany.

74 After the Wall was built in 1961, people were only legally allowed to leave East Germany and move to West Germany, if their application to leave was approved. However, with a view to East German economic interests, only a limited number of applications to leave were approved. These tended to be ones where the move to West Germany was motivated by a desire to be reunited with family members and were generally confined to elderly people. From 1984 onwards, the application procedure for leaving East Germany eased up somewhat, increasingly permitting younger people to leave the country. Such applications

their wives and their children Hannah and Jens at the end of the seventies. To begin with, direct contact across the border could only be maintained through Rahel's initiative, because as a recognized severely handicapped person, she was allowed to travel. However, her steadily declining health made it hard for her to make the trip. She suffered from asthma, an intervertebral disc disorder, sleeping problems and depressions. Rahel tells us of increasingly frequent battles with the authorities because they made visits from her sons very difficult or impossible. Reinhard was refused permission to visit her for seven years, something Rahel found very hard to bear. At the insistence of her sons, she eventually applied to leave and in the summer of 1989, left East Germany with her husband. In the meantime, her fourth grandchild had been born in 1982, Reinhard's son Adir.

Looking back, the 28 years that she lived in East Germany seem to her like self-punishment. Rahel said about her migration: *"That was the biggest mistake of my life"* and sees this phase of her life as *"fate"*.

After moving to West Germany, Rahel increasingly turned her attention to her Jewish family background and the history of her persecution. Jewish traditions that she had not kept in East Germany regained their importance for her. Above all, she began to feel the need to keep Jewish holidays and, by doing so, to pass these traditions on to the second and third generations. She is very supportive of her grandson Adir's interest in Judaism and occasionally keeps Shabbat with him. Keeping Jewish traditions has become something that binds the family together. The older she becomes and the more she feels worn down by her illnesses, the more Rahel grieves at the loss of her parents and longs to be united with them. She always gets especially upset at the time of the year when her parents were presumably murdered: *"But when that time approaches like now, (1) then I suffer (1) day and night."*

At this time of the year, her nightmares become more frequent and she feels the urge to go to the place where she presumes that her parents were murdered. The trip to Treblinka with her sons helps put her mind at rest somewhat: *"Then the children go with me to Treblinka, because I get so restless. And when I come back from there it's like a weight off my mind, then I think to myself, 'I stayed alive'."*

Rahel wishes to keep alive the memory of those who were murdered and of the persecution in her past by making these trips to Treblinka, which have taken on great significance for her since she left East Germany. She passes on this delegation to remember to her children and close friends. With this in mind, she has given them chain pendants with a Star of David and her con-

---

were usually accompanied by long waiting periods and subtle repression exerted by the state organs, (cf. Deutsche Bundestag publication, 1995; Ronge 1991).

centration camp number engraved on it. How do her sons live with this delegation and above all with their experiences of migration of which Rahel told us so little?

### *The second generation: a twin-like relationship*

The persecution in their family past and their life in the land of the perpetrators have pivotal biographical importance for the two sons, Dietrich and Reinhard<sup>75</sup>. Even a superficial look at their biographies shows striking parallels: after moving to East Germany, they both learned the same trade and lived with their mother until they had their own families. Both married non-Jewish women in 1970, and their children, Hannah and Jens, who were born shortly afterwards, grew up almost like brother and sister. After Reinhard applied to leave East Germany in 1976, Dietrich decided to leave the country as well. Reinhard moved to West Germany in 1978, and in 1979, the East German authorities approved Dietrich's application to leave the country. Dietrich and Reinhard are both convinced that they will leave Germany one day. Without ever having discussed the matter, it goes without saying for both of them that they will take this step together, too. The many things they have in common speak of a close relationship; however, a comparison of their live stories shows considerable differences.

The eldest son Dietrich: "My mother, my brother and I we are one soul"

Dietrich began his interview with this statement: "I was born in Kassel in Germany in 1946. From there my parents went to Belgium..."

He presented himself as a migrant, whose path of migration led from Germany via Belgium to Israel, then to East Germany and ended in West Germany. In just 28 lines, he had completed his account, which is oriented on the history of the family's emigration, with the remark: "*My life is not particularly special*". For Dietrich, the turning points in his life are associated with changes of place. A fifteen-year-old at the time, Dietrich especially experienced the emigration from Israel as a break in his life.

However, his loyalty to his mother prevented him from being able to speak openly about this. In reference to the family's migrations, he said at first: "*I'm sure my mother told the story better than I did, well I was relatively very young then*".

---

75 Dietrich Grünwald was interviewed by Maria Nooke in 1994. Reinhard Grünwald was interviewed twice, the first time by Maria Nooke and Bettina Völter and the second by Maria Nooke.

His close relationship with his mother binds him to her version of these events, at the same time allowing him to remain in the role of the "little son". At the beginning of our meeting, he described himself in terms of their close bond. He told us that he spoke to his mother on the telephone several times a day, had spoken to her directly before the interview and would call her as soon as it was over. It became apparent in the course of the interview that he avoids taking his own stance on things, referring instead to his mother or to his brother.

However, this presentation faltered in the sequences where he spoke of himself as an Israeli, presenting himself as a self-confident young man who knew exactly what he wanted. These sequences indicate clearly that he found it easier to live with the persecution in his family past in Israel:

*"It was nothing out of the ordinary that your parents had gone through something like that, these concentration camps and that you had no aunts, that you had no grandmothers ((takes a breath)) and no family. That was completely normal, because most people were like that."*

In Israel, he felt part of a community with a background of similar suffering. In contrast, when he and his family moved to Germany, he was confronted with the society that had brought forth the perpetrators of this suffering. In Germany, the persecution in his family past became a burden that increasingly got in the way for him.

Let us turn now to Dietrich's biography. His birth in 1946 in a Displaced Persons camp came at a difficult time directly after the liberation. It was a time when his parents were still desperately hoping to find members of their family and were searching for a perspective for the future. The emotional difficulties his mother was going through then were definitive for Dietrich's first few months of life. Rahel was struggling with conflicting feelings: on the one hand, she was happy about the closeness she felt to her child, but on the other, her infant son triggered the pain she felt in connection with the loss of her mother. Her relationship to her child was one of loving care but also one tinged with grief. This emotional ambivalence becomes apparent in Dietrich's present relationship to his mother, one defined by fear of abandonment, aggression and grief. The name he was given is linked to an ambivalent delegation, too. His parents intentionally gave him a German name; Rahel did not want her child to be instantly recognizable as a Jew. In Israel, this created problems for Dietrich.

In the summer of 1948, his twin brothers were born. The birth of the twins meant that a great deal of his mother's attention was focused on them. Like other children, Dietrich will presumably have been jealous of his little brothers and felt aggressive impulses towards them, as well as being afraid of

losing his mother's love and of being abandoned. This difficult phase for the two-year-old reached its traumatic climax when one of the twin brothers died at the age of six months. How did little Dietrich, who was two and a half years old when this happened, experience this event? He was at a phase in his development when toddlers want ever-greater freedom as well as needing loving attention from their mother. His security in his separation-individuation process will have been shattered by the death of his brother and his mother's reaction to it - she was preoccupied with grieving the loss of her child and presumably became overprotective of her other two sons at the same time. We can assume that this intensified Dietrich's separation anxiety and fear of losing his mother's love.

Furthermore, children under the age of ten have a tendency to attribute causes of death to magic and to imagine that they share some of the blame when someone dies (cf. Bank/Kahn 1982). It is completely possible that Dietrich unconsciously feels partially to blame for the death of his brother.

This phase of his life, one of symbiosis and individuation (cf. Mahler/Pine/Bergman 1975), was defined by insecurity. Traces of this found in Dietrich's adult life are his strikingly symbiotic relationship to his mother and to the other twin brother, Reinhard. The analysis of the family dialogue showed clearly the extent to which Dietrich identifies with his brother and the positively symbiotic attachment that he has to Reinhard, much like the bond between twins (Bank/Kahn 1982), and how he sees himself as inseparably bound to his brother. This is also apparent in his desire to be interviewed with his brother. He expressed the opinion that a joint interview would "*make more headway*". He was convinced that the individual interviews would be identical. In his view, he and his brother take the same course of action in any given situation. Dietrich's symbiotic attachment to his brother is an attempt to heal the trauma of loss in his childhood.

This need for symbiosis with his mother and brother grew even stronger in the phase of his life overshadowed by his separation from Israel. During the part of his childhood and early adolescence that he spent in Israel, he had an opportunity to identify with people and things outside of the home; this fostered the development of his autonomy and self-confidence. Even when he was going to nursery school, Dietrich insisted on having a hebraized name; in response, his parents gave both of their sons new names in memory of their murdered grandfathers. This is something that continues to be of importance to Dietrich. He spoke with pride of the fact that his hebraized name is written on a plaque at his old school. As one of its first pupils, he identifies with this school and helped to build it up. He has good memories of the straightforward way that children from different countries of origin played together.



*"All of them were in my situation ... all of them spoke their own language and yet we still got on very well together and we improved and learned our Hebrew together".*

He insisted that the family speak Hebrew and not Yiddish at home. But at that time, he wanted more than anything else to distance himself from the country of his birth, Germany: *"In Israel I was a man who was ashamed of having been born in Germany. The German language was something I- Germany was not a theme for me, I downright hated it."*

Against this background, moving to East Germany at the age of fifteen was something he experienced as a traumatic turning point. He was made to leave Israel without prior warning, with no time to say good-bye and, most of all, against his will, and to emigrate to the country that he utterly *"hated"*. Dietrich was particularly hurt by the fact that his parents did not take him into their confidence, but rather made the decision alone. The only time in the entire interview, that his pent-up aggression against his parents came out, was when he was talking about his last evening in Israel:

*"About our departure well I have to, normally I can't say anything about it, because I was under sixteen. And our parents and their friends decided it and we were (I) to put it plainly raped. We were just presented with the facts we're leaving Israel tomorrow".*

His use of the word "rape" shows how violently Dietrich experienced his parent's decision. He also spoke of rape at another part in the interview. This time, it came up in the context of his fantasies about his mother's persecution:

*"I assume just maltreatment and some kind of experiments on her body ... It's more a feeling of well between the lines uh that she well went through uh an awful, lot. Things that you have to be ashamed of that you uh well for example (I) when you get raped, like along those lines."*

Dietrich's choice of words indicates that he felt abused and at the mercy of others by being made to leave Israel similarly to how he imagines his mother felt in the concentration camp. However, his loyalty and bond to his mother prohibit him from reproaching her for this. And thus directly after the accusation he made above, he excused his parents as follows: *"My parents had a very hard time in Israel, too, especially my mother, because on top of everything else she was in a party that (I) was not particularly popular in Israel."* Because he is unable to reproach his parents, Dietrich can barely articulate this crucial turning point in his life and thus cannot express his grief and anger about the move. To this day, Dietrich accepts his mother's justification for taking this step and avoids questioning her motives. However, in the interview we discover that the fifteen-year-old initially reacted to the move by

falling into a state of active refusal. He refused to leave the house or learn German. The problems in the family became steadily worse. Six months after the move, Dietrich's father left the family and his mother became seriously ill. Dietrich was sent to a boarding school a little later. He accuses his father of having left his mother and the children in the lurch. In the interview, Dietrich said nothing more about his father and did not mention his death either.

If we examine the crisis in his biography as an adolescent, triggered by losing his life in Israel and being separated from his father as well as by the time he spent in boarding school, we can assume that the pain he experienced during his first few years of life was reactivated. We can deduce from the interview that Dietrich "solved" the crisis he was going through as an adolescent by abandoning the attitude of protest that he had taken on and forming a closer bond with his mother again.

While he was at boarding school, Dietrich fell in love, and the girl soon became pregnant from him. At his mother's recommendation, the eighteen-year-old got married, but the relationship broke up after just a short while. Dietrich moved back in with his mother and brother, even before he and his wife had separated. Dietrich began to adjust more and more to life in the new society. He acquired East German citizenship and, like other men of his age, completed basic military service as a soldier in the National People's Army. We discover nothing of what it was like for him to be in a German army. Dietrich resigned himself to his role as a citizen of East Germany. It was all the more unnerving for him when he discovered that his brother had applied to leave the country in 1976, without his prior knowledge. This triggered the old traumas of separation he had experienced in the past. Just like his parents had done years before, his brother had not involved him in the decision-making process. Now Dietrich was faced with a conflict: should he follow his brother and make an application to leave the country as well or should he stay with his mother. After struggling with the decision for a year, he applied to leave East Germany, too. When his brother was granted permission to leave, their mother reacted by having a nervous breakdown. This placed Dietrich in another conflict of loyalty, but one which his mother then released him from. Rahel told him that he needed to be with his brother and encouraged him not to withdraw his application to leave East Germany.

In West Germany, Dietrich oriented himself on his younger brother to a great extent. This is especially apparent in the fact that they work together in their own company. Although separated from his mother, Dietrich's close bond to her remained intact. Dietrich experiences her, as he does his brother, as part of himself; he can hardly put any distance between himself and them. His symbiotic relationship to his mother and brother emerged very clearly in the discussion of the family sculpture as well as when he was asked by the inter-

viewer to say one sentence to each member of his family. While he was able to verbalize his love for his wife and his son, he could find no words to say to his mother and his brother:

*"To my mother and to my brother there aren't any words I can say. My brother, my mother are like part of my flesh. I can't just say to my mother I love you (I) and to my brother (I) uh, how should I say it ... Well I'll describe it like this, that my mother my brother and I we're one soul."*

This symbiotic attachment to his mother or her incorporation is definitive of Dietrich's way of dealing with the persecution in his past. The murder of his grandparents and his parents' persecution are so frightening for him and so close that he cannot talk about them. He repeatedly emphasizes in the interview: *"I know all of that, I live with it, but I can't go into detail about it"*.

He lives with it as if it were a part of him. The minimal distance he has to his mother prevents him from being able to gain some distance from her experiences by transferring them into language. This becomes clear in his description of a visit to the Treblinka memorial:

*"When you get there (I) I have to say quite honestly, I=get goosebumps. You can't I can't talk about that. (I) You can't talk about that, you can- you have to live through it ... Well I can't talk about that ... It's impossible to describe, well for me impossible to describe (I) what the woman goes through there ... Well I have to be in very good shape to get my mother out of there healthy, that she doesn't somehow: (I) like 'n attack or (I) that's what I'm afraid of."*

Dietrich's biggest fear is that his mother might die and he and his brother would have to go on living without her. To escape this experience, he hopes he will die one day before his mother.

The second son Reinhard: identifying with his father

Unlike Dietrich, Reinhard took on the delegation of reminding others of the persecution. Like his mother, he was also worried about how we would deal with the interviews and whether we were considering publishing them. He, too, is very concerned about how the Germans deny this chapter of their history. It was his intention to use the interview to commemorate the persecution in his mother's past but also that in his father's. He knows more about the persecution than his brother does and, what's more, can talk about it.

Reinhard tries to separate the persecution that his parents suffered in the past, and the impact that this had on the family, from his own history. He told

us that he only wanted to talk about his own life in Germany, his problems in this country and above all the way he rebelled against East German society in a second interview. He said that it would be too much for him to combine his family history and this theme in one interview. We interpret this separation as an indication, that he wishes to separate the habitus of protest that he adopted from his relationship to his family past and to his mother. By doing so, he avoids seeing himself as a victim and criticizing his mother for imposing a life in Germany on him.

Let us first examine Reinhard's life history before his emigration to East Germany. He embedded his life story in the story of what happened to his family after the Shoah: *"After an odyssey through Europe my parents as I said came to Belgium, where shortly after (1) the birth of twins (2) took place. One of them died unfortunately, I'm the other one, who survived it."*

The beginning of his life was linked to a very early experience of loss, to death and to survival. The death of his twin brother Christoph was presumably of crucial significance for Reinhard's individuation development. For twins, the mother is not the only object of love in their earliest childhood; rather, they live in physical symbiosis and as such are even more continuously available for one another than their mother (cf. von Schlieben-Troschke 1981, p. 125 ff.). Twins experience themselves as part of a whole. They identify very strongly with the other and see him or her as "part of themselves". The death of his twin brother in an early phase of his life, at six months, meant that Reinhard lost his brother at a time when he still experienced himself and his twin as an inseparable unit. The identity problems often observed in twins, the question of "am I similar to or different from my twin brother" (v. Schlieben-Troschke, p. 135) were intensified for Reinhard by his parents' lack of certainty about which twin had died. Rahel related that both children were sick at this time, recalling:

*"Now I don't know for sure, which child died (1) because they usually had a little band, because as identical twins of course they were very similar ... And we didn't know (2) and somehow it occurred to me that Reinhard was alive (1) ((soundlessly)) and that Christoph had died."*

This poses the question for Reinhard of am I "me" or am I the "other one". And it was thus his mother who made the decision, that Reinhard was the one who survived and Christoph the one who could not go on living.

Unlike Dietrich's account, Reinhard's stories of his life in Israel were primarily connected to his father, whom he identifies with. Reinhard has an image of his father as an Israeli soldier from his earliest memories. For his second son, Aaron symbolizes the fighter; but his father was also the one who acquainted him with the persecution in his past.

For Reinhard, this past is linked to a delegation to actively resist anti-Semitism.

Reinhard recalls how his father told him about his family and life before the Shoah and had made an effort to familiarize him with Jewish culture and Yiddish: *"He often took me to Jewish theatres so that I would get to know the Jewish language and so that I would get to know Jewish culture and strangely never took my brother."*

The closeness between the two and Reinhard's identification with his father becomes apparent in his depiction of his parents' persecution. He talked about the persecution suffered by his father and his father's family first. His portrayal of this part of his family history is linked to the themes of "resisting the Nazis, flight and death". Reinhard told us that his father was brought to a forced-labour camp in 1939 and was later taken to Buchenwald. He hinted that he was exposed to horrific acts of deliberate cruelty and was one of the survivors of the death march from Buchenwald to Theresienstadt<sup>76</sup>. Like other members of the second generation, Reinhard spoke primarily of his father's active deeds, such as his attempts to escape:

*"He tried to get away (1) from Buchenwald, two attempts to escape. (1) Once they'd already put up against the wall (2) and (1) shot him (1) and he fell over but wasn't dead. And then came the SA or SS man, went with his foot "Aw the Jew's dead". And they kept going and my father took off, but was caught again (1) 'cause the body wasn't there, when they came back, this other unit you know? And then the business of searching for him got going again."*

Reinhard recounted other examples documenting his father's courageous behaviour. But he himself is not quite sure whether he can believe these tales: *"Asking questions well I wasn't allowed to ask questions. I don't know whether it's fair to say you weren't allowed to ask or he forbade me to, you know? I never asked questions, he told me things. My father told me about Barrack Seven."*<sup>77</sup>

Reinhard told us that, during a visit to the Buchenwald memorial, he found out that members of the Resistance were housed in this barrack. It is important for him not to see his father as a defenceless victim but as someone who put up resistance.

---

76 On 10 April 1945, one day before the camp was liberated, 1500 inmates and 500 Soviet prisoners of war were evacuated from Buchenwald and marched towards Theresienstadt (Carlebach et al, 1988, p. 186). Those who survived reached Theresienstadt on 7 May 1945 (Drobisch 1977, p. 153).

77 The Soviet prisoners of war were housed in Block Seven (Drobisch 1977, p. 136). There was an illegal group of the Communist Party of the Soviet Union there (Ibid, p. 57).

In contrast, he sees the persecution in his mother's past from the perspective of her suffering and the dehumanization that she had to endure. He sees his mother as a little child who suffered indescribably. Much like his brother, he is preoccupied by the physical abuse that the female inmates suffered at the hands of the SS: *"They made the whole, barrack (2) take all their clothes off and stand on the roll call- roll call grounds like eight (1) twelve hours ... If one of them fell over, they were shot right away, well 50 girls for sure died from this roll call, she says."*

He associates upsetting fantasies with these roll calls. When asked which of his mother's experiences upsets him most, he replied: *"The roll calls (3) yeah (3) the roll calls and this ((takes a deep breath)) (1) setting-, dogs on people (1) And that's the same with me too. (1) I'm afraid of dogs too."*

Reinhard sees his fear of dogs against the background of the persecution that his mother experienced. We will see the intergenerational impact of this trauma of persecution when we look at the interview with his daughter.

People who helped his mother survive this difficult time emerge in Reinhard's description of the period when his mother was persecuted. He mentioned the director of a factory that she had to work at:

*"There was one of these selection procedures again ((sniffs)) (2) and (2) "you to the right you to the left" (2) and she ((his mother)) was supposed to go to the left and then this director said "No (1) I'll keep the girl". And the ones who went there, didn't come back. They all went into the gas chamber".*

While the outcome of the selection procedure in Rahel's story remains unclear, in Reinhard's conception of it, this man saved his mother from the gas chamber.

Let us examine now how Reinhard experienced the move to East Germany. He described the oppressive atmosphere that surrounded their arrival:

*"We arrived in Germany (2) on the eleventh of the eleventh (1) sixty-one (3) it was raining (2) dark (1) we were picked up by Stasi cars ... We had flown in from Zurich, everything brightly lit. Here slot machines there street-cars, we were crazy. (1) Asian children in a country like that and then here. We get out, everything's dark ... And (2) even then I already - we already said well uh (2) we're not going to be happy any more."*

This description gives an indication of how problematic the period that began for him now was. Thirteen years old at the time, Reinhard only found out where they were going in the airplane. While his brother Dietrich spoke about his last evening in Israel and gave us a sense of how heavily the loss of his life in Israel weighs on him, Reinhard presented the beginning of an oppressive period in Germany. Reinhard also avoided talking about his parents'

separation, which occurred in this period. Even when we asked questions, we discovered only that his father had already left the family by May 1962. It must be assumed that this period was very hard for him. His father left the family, his mother suffered from heart trouble and later his brother was at boarding school. Before he could even speak the language, Reinhard had to go to school. He became a member of the East German state youth organization, the "Free German Youth" (FDJ), and took part in preparations for the Initiation Ceremony (Jugendweihe)<sup>78</sup>. It was within this framework that Reinhard went on a class trip to the former concentration camp of Sachsenhausen. This trip was a key experience for the fifteen-year-old. He felt included in what had taken place at that time and felt threatened himself. Reinhard felt a growing closeness to his mother and the persecution in her past: *"I came home and said: 'Mummy (2) I know what a terrible time you had' and straightaway took my mother in my arms. I'll never forget it, that day was a Tuesday, I'll never forget it."*

It became clear to him through his visit to the concentration camp memorial that he was a Jew living in the land of the perpetrators. This sense of being in danger, because he was Jewish, became increasingly unbearable for him in the years that followed in view of experiences of anti-Semitism: *"Always these difficulties Jews Jews Jews (2) without it being (2) meant that way or whatever (1) but that was the point, where I was vulnerable."*

He began to rebel against stigmatization and anti-Semitism and in the period leading up to his departure for West Germany got into a number of fights that eventually landed him in prison for a time. His conflict with Germany became a substitute for the conflict generated by his parents' decision to live in Germany. Like his brother, Reinhard does not question the motives behind this decision either. However, he did express the idea that their departure from Israel may have been connected to political contacts to Arabs. We can assume that Reinhard secretly doubts his parents' justification or even knows more about it than he was willing to share with the interviewers. But his loyalty to his mother does not allow him to address this theme.

Let us look now at how the next few years of his adolescence in East Germany progressed. At the age of sixteen, he went into vocational training and moved into an apprentices' hostel. It was during this period that he had his first experiences of anti-Semitism. Other youths attacked him, saying that Jews should not even be trained at all, that they were only of any use as labour, that it was a shame that they had not all been gassed.

---

78 A ritual organized by the East German state to "receive young people into the ranks of adulthood".

Reinhard had a growing sense that he was different and was being rejected. Nonetheless, he tried to integrate, working in the Free German Youth organization along with the others. But the functionaries did not even come to his aid when he was verbally abused as a "*Judenschwein*" (Jew-swine). Reinhard came to the conclusion that he had to defend himself. The upshot of this was fist-fights that gained him the respect of the other adolescents. But at the same time, these led to new conflicts that isolated him even more. Reinhard increasingly withdrew from the life that had been forced upon him. In the years that followed, situations cropped up time and again, in which he experienced anti-Semitism and fought back against it with his fists. It emerges in the interview that he saw his physical strength as the only reliable means of tackling difficulties. Reinhard came to the conviction that he could only survive on his own strength.

The situation escalated when he was drafted into the army for basic military service. He felt trapped and powerless. The atmosphere in the barracks, especially the roll calls, triggered his fears and he associated it with his mother's experiences in the concentration camp. Once when without permission he entered a military installation guarded by dogs, he felt hunted in a way much like his mother had been during her persecution. His sense of being in danger grew ever-stronger. Being integrated into the institution of the army and its insistence on unconditional obedience eventually led to him having a total crisis. The *éclat* came during morning roll call. "*I was standing at roll call early one morning (1) and I was still yawning, couldn't help it. And then the officer said to me in front of all the men (2) 'Well children of Moses can't sleep'. (3) And my nerves snapped.*"

Reinhard beat the officer up. It was only when another officer pointed a weapon at him that he let off. He was arrested and sentenced to sixty days in solitary confinement. When we asked him about his memories of this imprisonment, he said: "*The solitary confinement was well uh (1) in principle no different than under Hitler.*" He describes the terrible conditions in the narrow damp basement cell that he was locked in. The worst for him was that he could not physically act out his feelings. He had no way of using his own strength to defend himself in this situation. Other experiences from his time in the army show clearly that he was no longer prepared to submit to the demands of the system. In the summer of 1968, during the crushing of the Prague Spring, he refused an order when his unit was scheduled to be transferred to near the Czech border. Reinhard mentions being arrested on another occasion, too. But even though she asked questions repeatedly, the interviewer was unable to ascertain why, how long and where Reinhard was arrested. While in his life story up to this arrest he presents himself as a fighter, he more or less omits from his presentation the next seven years that he spent in



East Germany before he left the country. We do not discover why his arrest led to a biographical turning point. Let us examine his biographical development over the years that followed.

After he had finished serving in the army, Reinhard met up with an acquaintance with whom he had gone through vocational training. The couple married shortly after because of the imminent birth of their daughter Hannah. Reinhard's wife Monika is non-Jewish and comes from a church-going family. As an adolescent, she had neither taken part in the Initiation Ceremony nor been a member of the Free German Youth organization. By choosing Monika as a partner, Reinhard was taking the process of distancing himself from the East German system one step further.

The young family lived with Rahel at first and had little contact to Monika's parents. Reinhard's father occasionally came to visit him. His father's death in a car crash in 1975 on a trip to his home town of Czestochowa was very hard for Reinhard. He went straight to the scene of the accident and received permission from the East German authorities to go to his father's funeral in West Germany.

In the period that followed, Reinhard sought contact to the Jewish Community. In 1976, he decided to apply to leave East Germany with his family for Israel. The East German authorities rejected his application, saying: "*You can't move to Israel (2) Israel does not exist and you sure don't want to go to Palestine*".

After this application was rejected, he applied to leave the country for West Germany. After two difficult years, in which Reinhard was put under considerable pressure by the authorities, he was allowed to move to West Germany with his wife and child in February 1978.

Reinhard explains his desire to leave East Germany with the repressive measures that were inflicted on him. But perhaps his decision was also linked to the fact that the year before he made his application, his father had died and his mother had remarried. In West Germany he was able to reexamine his father's past. Like Aaron, Reinhard joined the Jewish Community after he moved, consciously embracing his Jewish background. His wife converted to Judaism around the same time. But Reinhard felt out of place in West Germany, too. The move had not solved the problem of living in Germany for him. He accuses the Germans of neglecting their duty to educate people about the Shoah and sees it as his responsibility to keep the memory of the Shoah alive. He does not relate this role to the general public, however, but just to his own family. His self-conception of being responsible for keeping the family together is manifested in his family sculpture. He gives his brother the role of head of the family, while he himself makes sure "*that no one gets out of line*". He sees it as his responsibility to take care of his mother and to involve

his children in this process. After his move to West Germany, he started bringing up his daughter Hannah and his son Adir, born in 1982, according to Jewish traditions and expects them to comply with his ideas. He forbade his daughter to have a non-Jewish German boyfriend, for instance. Reinhard has a close relationship to Hannah and feels especially responsible for protecting her. Let us now examine the role that his wife Monika assumes in the family system.

#### Reinhard's wife Monika: separation anxiety

Monika<sup>79</sup> finds it very difficult to talk about herself and her family. She was born in East Germany in 1950. Both her parents' relationship and the family's economic situation were extremely troubled. As a result, she was given into the care of her mother's step-parents for a lengthy period of time as a small child. The tensions between her parents dominated her family life. Her father, an alcoholic, had numerous relationships with other women. Monika, who identified more with her father, was very unsettled by these conflicts. Her parents divorced when she was twelve years old. At the age of sixteen, she went into vocational training as a paediatric nurse and left home. During this period, she met Reinhard and was attracted by his manliness. But it was only after he had been in the army that a relationship formed between them, one that quickly led to marriage when Monica became pregnant. Monika oriented herself on her husband and his family and left the decisions about their shared life up to him. After they moved to West Germany, she converted to Judaism.

Monika's life is defined by her need for security and her fear of being abandoned. An analysis of her interview indicates that this anxiety stems from her mother's background. Deborah<sup>80</sup>, her mother, was born in Hamburg in 1927, the illegitimate child of a Catholic woman from Upper Bavaria. Her mother gave her into the care of a home for infants right after she was born. At the age of eleven months, Deborah was taken out of the home by her mother's parents. She grew up with her grandparents and only saw her mother when she occasionally visited. Her grandparents were enthusiastic members of the Nazi party and brought their granddaughter up with these values. After her grandmother died in 1938, Deborah was given into the custody of her father, whom she hardly knew. In 1940, on leave from the frontline, he brought her to Hamburg. From then on, Deborah lived with her stepmother, and sometimes even with her step-grandparents, to whom she later entrusted her own daughter. Her father was killed in action in 1943. Deborah's child-

---

79 Monika was interviewed by Maria Nooke in 1995.

80 The author interviewed Deborah on two occasions in 1996.

hood is marked by constantly changing reference individuals, some of whom were complete strangers to her. It suddenly occurred to Deborah during the interview that, based on what her mother had told her, she must have already been pregnant when she met Deborah's father. Deborah realized that according to her mother's statements, her father could not have been her biological father. She was shocked and bewildered at this realization and changed the subject. What could be hiding behind the secret about her father? Why did her mother hide her real origin from her? Deborah's mother left her parents' home because she was pregnant. She worked in Hamburg as a maid in Jewish households and boardinghouses and only returned to her Catholic hometown after the death of her mother in 1938. Deborah's Jewish name also begs the question of her descent. What Deborah does know about her mother is that she witnessed the persecution of Jews, whom she was acquainted with, and that she still keeps a letter from acquaintances who were in Theresienstadt. However, Deborah does not go any further than that towards confronting this theme or her mother's behaviour during this period.

It is striking in Deborah's life history that she has converted many times. She was baptized a Protestant at the instigation of the man whom she had presumed to be her father, converted to Catholicism at the request of her grandmother and then took on the Protestant faith again when she married her first husband. In each case, her converting was directly connected to changing reference individuals. Thus we see a link in her life history between unstable relationships and changing religious affiliation. In her daughter's case, the significance of converting to Judaism was stabilizing Monica's relationship with her partner.

The family constellation took on another dimension when Reinhard and Monika married. While the grandmother Rahel still suffers from the loss of her parents and binds her sons to her, Monika's family of origin is dominated by unsolved questions of extraction and emotional affiliation.

### *The third generation: a need for distance*

Let us move on to Dietrich's son Jens and Reinhard and Monika's daughter Hannah<sup>81</sup>. Let us recall what the family past means to their fathers: Dietrich cannot speak about the persecution as it is an inseparable part of him, whereas Reinhard takes on the delegation of keeping the memory of the Shoah alive within his family. Dietrich remains his mother's son and has difficulties assuming the role of father in his relationship to his own children, while

---

81 Hannah was interviewed by the author in 1995 and Jens in 1996.

Reinhard feels responsible for protecting his children and his mother. Reinhard also has close ties to his mother.

As the interviews with their children Jens and Hannah indicate, both grandchildren suffer from the symbiotic relationships in their family. The burden of persecution in their grandmother's past weighs on them and they deplore the silence surrounding it. They have no more than a fragmentary knowledge of their family history. They know that their grandmother comes from a religious family, but do not know where she was born or which concentration camp she was incarcerated in. They know nothing of the persecution suffered by their grandfather on their fathers' side. Confusion also reigns about the family's move from Israel to East Germany. Jens assumes that his grandfather wanted to go to East Germany and cannot comprehend why he is buried in a graveyard in West Germany. Hannah is convinced that her grandparents had already separated in Israel and can see no reason for why her grandfather went to West Germany alone. However, this family secret concerns her far less than the persecution in the family past.

The grandson Jens: "It's always hanging over everything like a shadow"

Jens was born in 1972 in East Germany and was seven years old when the family moved to West Germany. In his biography, too, migrations are significant for his life history. Unlike his father, whose separation-individuation process was disturbed by migration to East Germany, migration has given Jens an opportunity to gain autonomy.

After finishing high school, he went to Canada for a few months. During his stay, he met the woman who was to become his wife: a Canadian Jew, whose grandparents were Holocaust survivors. On the strength of this visit, Jens decided to emigrate and set about pursuing this goal single-mindedly. He has been living in Canada now since he was twenty-two years old. This geographical separation has allowed Jens to gain some distance from his family and to begin to build up his own life.

Jens was interviewed during his first visit to Germany since he emigrated. The main theme that concerned him in the interview was the impact of his grandmother's experiences in the concentration camp on his family, without them actually being the subject of discussion. Instead of telling his family and life history, he proceeded to talk about this theme, addressing the silence in his family as the main problem. He also accused his grandmother of making everyone dependent on her. He argued that, since she did not talk about her past, he did not know what she expected him to show understanding for. But it was just as impossible for him to discuss what weighed on his own mind. In the interview, he referred to it as "*that theme*". Jens began the interview with

the words: *"My life story had absolutely nothing to do with that 'theme' for the first fifteen years of my life. During the first fifteen years I didn't find out anything at all, about what happened there, because it was not talked about."*

Jens was fifteen years old when his grandmother moved to West Germany. The direct contact that he was now able to have with Rahel and the close family relationship made the persecution in the family past meaningful for him. Jens made it clear that he had been concerned with *"what actually happened and what went on"* since then. For him, the things, that are not talked about, feel like a shadow hanging over himself and his family: *"It's there in every aspect of life (1) in every aspect. It's present at every festivity (1) at every event. If it's not talked about you sense it. (You sense) it's like a big cloud that doesn't go away."*

He deplored that he could not pass these memories on, because he said that he had not been told anything and stressed that, what he did know about the persecution, he had found out himself. On his own initiative, Jens went to former concentration camps to discover something about the Shoah. The fantasies, that he associates with it, disturb him deeply. He does not dare to imagine how his grandmother survived the terrible time in the camp:

*"I couldn't even, because I had no information at all. How she was, where she was, whether she was in a small building, big building. How many she shared a bed with (1) and (1) how many people around her uh (1) died. And how she was liberated, how she was treated. I don't know any of that."*

He repeatedly expressed the hope in the interview, if he knew what had gone on, it would help him shake off this oppressive shadow of persecution. At the same time, he finds it too threatening to expose himself to this knowledge. Thus, at the time of his interview, he had not yet listened to the tape recording of Rahel's interview which she had given him as a parting gift when he was leaving for Canada for good. His visit to Germany confronted him again with the fact that *"that theme"* in connection with his family has not gone away for him. His experience of the new distance he gained through his life in Canada contrasts with his tormenting experience in Germany of how problematic remaining silent about the past can be: *"I think it's not open, it is not on the table, it's always under the table and like a shadow over our family. And it's always there, without anyone talking about it. (2) Like a closed book that you can't open, aren't allowed to open."*

Jens senses the impossibility of confronting this problem alone. As important as a more detailed knowledge of the terrible things, that his grandmother lived through, could be for him, an open dialogue in his family could go still further towards making the experience of looking at the persecution in his family past a less threatening one.

The granddaughter Hannah: "I have the feeling that I'm too deeply involved in the family"

Reinhard's daughter Hannah was born in 1970. Like her grandmother and her father, she wanted to know beforehand what was going to happen to the interview and whether it was going to be published. However, her worries centred on things she planned to say getting out to other members of her family. The interviewer's assurances, that nothing she said in the interview would be repeated to her family, were important to her, because she said that she was going to say things that would hurt her father and grandmother. Hannah tried to present herself as an independent person beginning to loosen her close ties to her family. At the beginning of the interview, she talked about the first seven years of her life in East Germany, linking these to the break in her family and life history that took place with the family's move to West Germany. She presented the first seven years of her life as a happy time. But the fears, that she had as a small child, also came up. Hannah told us of a large dog that used to frighten her when she was playing in the yard. While Hannah's father is able to relate his fear of dogs back to his mother's experiences of persecution, the background to Hannah's fear in the family history is not clear to her. Hannah recalled other childhood fears, too. She remembers waking up one night when her parents had left her alone. She can clearly remember calling for them and getting no response. She still imagines this situation today and we may ask ourselves whether there is any connection here to her mother's fears of abandonment.

For the seven-year-old girl, the move to West Germany was linked not only to a dramatic change in her surroundings, but also to her family's involvement in Jewish life. Hannah felt ambivalent about these changes. In the interview, she described the external change of scene positively, associating it with an enticing and vivid world. The problematic part for her had to do with the new social contacts that became definitive for her life at the time. During this period of change, the young girl oriented herself on her mother. While she repeatedly portrays her father as the one who made the decisions, her mother is associated with responsibility for social contacts. Hannah started going to a primary school with a relatively high proportion of Jewish children and after school, she went to the Jewish Community Centre day-care centre. There she became familiar with Jewish festivals and rituals, which were very new to her. Just less than a year after the move, when she was eight years old, Hannah and her mother converted to Judaism. In the interview, Hannah accused her mother of making her into a Jew this way. She said that a decision was made for her without her permission about which faith she should belong to. Referring to the Mikvah, she said:

*"We came into this room there ((swallows)) well there were several there who were converting. I can't really remember any more (1) and there (2) then we had to get undressed but then in front of the door I (1) the door was closed and then we had to get undressed and plunge into a sort of basin. And the Rabbi he said something then and we had to repeat it after him and then well go right under in this cold basin of water and then get dressed again. That was it really and I didn't even really know what was actually going on here."*

Hannah was so afraid that she urinated in the basin. For her, the ritual embracing her into the Jewish community is associated with fear and feelings of being at the mercy of others. The way Hannah describes it is reminiscent of Rahel's experience of persecution. Like Rahel, Hannah makes it clear that she felt at the mercy of others because she did not know what was happening to her. The way she associates her fears with nakedness also points to the experiences in Rahel's background. While to Monika, converting to Judaism meant stabilizing her relationship to her partner, it made Hannah feel at the mercy of the persecution in her past, which she finds threatening. What emerges in the analysis of the interview is her latent desire to be able to see herself as non-Jewish by identifying with her maternal line, and by doing so, to put some distance between herself and the persecution in the past of her father's side of the family. Her mother's converting makes this option less open to her.

Her close bond to her father also makes her feel entangled in the symbiotic family system which is dominated by her grandmother Rahel. Hannah accused her father of never having separated from her grandmother:

*"I just think that he somehow hasn't cut the umbilical cord that joins him to her, that there's still an incredibly thick umbilical cord, that still binds the two of them really tightly together... Sometimes he tries to build up this umbilical cord to me, and that's why I put up a fight."*

It was her father who confronted her with the reality of the persecution. When she was twelve years old, he let her watch documentary material on television. She recalled:

*"It was like film scenes, where they wheeled out the dead and how I sat in front of the TV, and stared at it and couldn't comprehend what I was seeing there at all. Stared at it. And then my father said: 'Your grandmother was that thin too'. And I just kept staring at it and didn't get what he was telling me and I didn't get what I was actually seeing there either. But the images kept coming back to me at night".*

Hannah suffers from nightmares, panic attacks at night and depression. She is haunted by images of piles of dead bodies and emaciated people. This also emerges from her description of a film that she saw with her class when she was in high school:

*"We went into the room and the film was shown, it was a documentary film black and white, and some SA or SS man must have filmed the Jews ... and again a group who were going somewhere maybe they were just going to have their hair cut off before they went into the gas chamber ... And they sang a Yiddish song that I knew, that was too much".*

Hannah left the room. It was unbearable for her to cry in front of non-Jewish fellow students who did not comprehend the significance these images had for her. Hannah sensed how close she felt to the survivors. This was also on her mind when she was preparing for the interview. Like her uncle Dietrich, she feels a (physical) oneness with her grandmother:

*"Because my grandma because I'm a part of my grandma and because I also have a part, I wasn't in a concentration camp myself but maybe some part of me was. I sometimes- we don't know how it works, what happens between people, you know? What's passed on through the generations, what continues in the blood or in the genes or in the soul or whatever."*

Hannah's desperate attempts over the past few years to distance herself from her family and from Judaism are an effort to achieve separation and with it some distance from the Shoah and the fantasies that she finds so threatening. The process of separating from her family started with her stay in Israel. After finishing high school, she worked on a kibbutz for several months. This was a carefree time for Hannah. She felt happy among the other young people and fell in love with a Swede. At her family's urging and her father's threat to come and get her, she returned to Germany when the Gulf War started in January 1991. This was the end of her relationship with her Swedish boyfriend. The period that followed was one that Hannah described as the *"process of cutting the umbilical cord"*. She told us of various relationships that she had had, including one with a Palestinian. But she kept this relationship a secret from her father.

Hannah left home at the age of 22. She still has problems managing on her own. For a long time, she visited her parents and her younger brother every day and slept over in their apartment. Hannah has little contact to her grandmother Rahel, despite her father's constant urging that she see her more.

In 1995 she went into client-centred therapy, which has a stronger focus on the present than on the past. Hannah feels a need to talk about her problems, something not possible within her family. In Hannah's view, all the con-



flicts in the family are suppressed out of consideration for her grandmother. It was during this period, that she met Florian, a non-Jewish German, whose last girlfriend had taken her own life. Hannah persuaded Florian to move into her apartment. This led to an escalation of her conflict with her father. Reinhard threatened his daughter that he would break off all contact to her if she married a non-Jewish German. Florian accused Hannah of using him in her conflict with her father, but also of not being able to separate from him. Hannah insinuated that Florian was trying to separate her from her father and her family. Hannah's fear of being abandoned intensified in this conflict. Her separation process is fraught with fear of forming attachments, loyalty to her family and a desire to separate from her family and the persecution in the family past.

With Florian's help, Hannah was able to look more closely at the problems in her family. By getting involved with him, she was bringing someone into the family system who took on the role of questioner.

Florian, who was present during part of the interview with Hannah, reflected upon his own perpetrator traits as a non-Jewish German. He addressed this theme in connection with the family of Hannah's mother, as well. With Florian's help, Hannah has started confronting the blanks in her grandmother Rahel's story. She has begun to wonder why her grandmother decided to come to Germany of all places, as has Florian. It seems strange to both of them that Hannah's grandmother was not more politically active in East Germany, considering that in Israel she was apparently very much a strong woman in the public eye. Although Hannah accuses her grandmother of keeping her father dependent on her and dominating the family with her sufferings, at the same time she feels understood by her grandmother when she talks about her depression.

However, in Hannah's case, none of this ambivalence has led to her avoiding a confrontation with the persecution in her family's past. On the contrary, she has recently begun to deal with it creatively, using art to come to terms with the persecution in her family past.

## Summary

The extent to which the Kubiak/Grünwald family is defined by symbiotic attachments is striking. Close ties between the generations, which make the separation-individuation process much harder for the children and grandchildren, are dominant traits in other families of survivors, too, but are intensified in this family by its history after the persecution. The death of Reinhard's twin brother is partially responsible for the relationship between the two surviving sons, who in many ways relate to each other like twins. Their migration to

East Germany and separation from their father made their bond to their mother even closer.

Like other daughters and sons of survivors living in Germany, the sons in this family are unable to openly work out their difficulties with living in Germany within the family, as doing so would mean reproaching their mother. While the eldest son, Dietrich, remains completely stuck in a symbiotic relationship to his mother, Reinhard has been able to distance himself a little more through by rebelling against life in East Germany.

The grandchildren in this family suffer from these close relationships and are trying to disentangle themselves from them. The granddaughter Hannah tries to do this through relationships to non-Jewish boyfriends and the grandson Jens by emigrating to Canada.

Part 3:  
Israeli Families of Forced Emigrants from  
Germany



## 10. Families with grandparents of the "Youth Aliyah generation"

Gabriele Rosenthal, Bettina Völter and Noga Gilad

The initial situation of German emigrants in Palestine

*"There were about two hundred of us ((young people, Ed.)) and we were divided up among five different kibbutzim, it was August 1937 when we arrived. I didn't speak for half a year, on kibbutz K. they only spoke to us in Hebrew. After half a year a good friend of mine said a German swearword. I said "What? You can speak German". He said "Now it's okay for you to know." That was hard. But the news from Germany was even harder...we were more afraid, we heard more than our parents in Germany. We always told them to come, come, come."*

We took this quote from an interview with an Israeli man who managed to emigrate from Germany to Palestine as a sixteen-year-old boy in 1937 as part of the Youth Aliyah. His parents were unable to leave Germany in time; they were murdered by the Nazis or their accomplices. In this brief sequence, Mr. Jarkoni expresses what may well have been the most significant biographical constellations of his generational unit: in Palestine, these young people found protection and even recognition, but at the same time, they were under strong pressure to conform, which, among other things, required that they deny their German socialization and their bond to Germany. But their difficult start in a new country was completely overshadowed by the news that reached them after they immigrated. They heard of the persecution, and later of the murder, of family members, of their parents, grandparents, siblings, and other close relatives and friends. This further biographical dynamic, linked with the initial constellation, was definitive not only for this generation, but also for the dynamics in their families and for the biographies of their children and grandchildren, too. A central theme here in each generation is their individual stance on Israel and to Germany.

Jews from Europe, who fled the Nazis between 1933 and 1945 and either directly or via third countries came to Palestine, at that time under British mandate, increased the Jewish proportion of the population there, the "Yishuv", by approx. 150%. Whereas in earlier waves of immigration<sup>82</sup> the

---

82 The first three waves of immigration (in Hebrew: Aliyah) came mainly from Russia, with the fourth coming from Poland. The first Aliyah was in 1882; the second, connected with

majority of immigrants (Olim) had come from Eastern Europe, this fifth Aliyah included many Jews from Germany and Austria. Depending on the source, German-speaking Jews made up between 20% (Segev, 1995, p. 52) and 30% (Pinner, 1972, p. 89) of the total immigration of this Aliyah. Of these approx. 52,000 German-speaking Jews, some 5,000 twelve to seventeen-year-olds came into the country without their parents, as part of the Children and Youth Aliyah, a project which came into being in 1932 in Germany.<sup>83</sup> The Youth Aliyah, a form of organized group emigration, with which Mr. Jarkoni and another 3261 boys and girls (Wetzel 1988) immigrated to Palestine, was an option for young people over the age of fifteen who had gone through vocational training in Germany to prepare them for immigration. The declared aim of the Children and Youth Aliyah was to train young immigrants for life in an agricultural settlement.

Most of the children and young people went to a kibbutz in Palestine. The same was true for young adults, who could immigrate to Palestine after completing craft trade or agricultural training, generally lasting one and a half years, provided for young people over the age of fourteen by the Zionist Palestine organization "Hechalutz" (Hebrew for pioneer)<sup>84</sup> at training centres, training camps and farms. In Germany in 1935, what was known as the youth Hachsharoth was institutionalized especially for young people between the ages of fourteen and eighteen (Reinharz 1986, p. 327).

Thus, German-speaking Jews came to a country populated by a Jewish community consisting mainly of Eastern European immigrants, who had not come to Palestine because of National Socialism and who for the most part did not experience their Aliyah as "deliverance", but rather as "salvation". They had generally come to the country because of Zionist motives to found and build a Zionist state. In contrast to Eastern European Jews, German, Austrian, and Czech immigrants, too, were often from the assimilated middle class; they were well educated, professionally qualified, and financially well

---

persecution in the context of the war and revolutionary unrest in Tsarist Russia, was between 1904-1914, and the third Aliyah started after World War I. The fourth Aliyah was between 1924 and 1931 (cf. Schreiber/Wolffsohn 1989).

83 These figures refer to the period between 1934 and the end of March 1939. However, they vary depending on the source. Segev (1995, p. 225ff.) speaks of 5000 children and young people coming from Germany by 1939, whereas Pinner (1972, p. 95) puts the figure at 4788. Even during the war, several thousand children and young people managed to immigrate to Palestine (Segev quotes 10,000, with Pinner, in contrast, referring to just 2618). Also, from the end of World War II to the founding of the state of Israel, another 15,000 young people managed to emigrate to Israel as part of the Children and Youth Aliyah project.

84 The "Hechalutz" organization was founded in 1918 for the purpose of carrying out vocational preparation for the Aliyah. Such training also implied the possibility of later immigrating with a "worker certificate". The vocational preparation, which included Hebrew lessons, was known as "Hachsharah" (training).

off due to the Haavara transfer system<sup>85</sup>. As a result they encountered considerable resentment from the Jewish population already living there. Apart from all the taunting and jibing about their German character, particularly their obedience to authority, they were reproached with not being real Zionists, it was said that for them Zionism was only a means to "deliverance". Tom Segev illustrates this attitude by citing the example of the then Prime Minister Ben Gurion, who shared many of the negative clichés about the "Yecken" and made fun of their "longing for German culture and their embarrassing law-abidingness" (Segev 1995, p. 84). This widely-held attitude even went so far as to put some of the blame for Hitler's seizure of power on German Jews. Whereas young or middle-aged adults, who had come into the country on "capitalist visas"<sup>86</sup>, were more likely to conform to the cliché of the German Jew, who preferred life in the city, which revolved around culture and trade, than life in agricultural settlements, this cliché was not true of the children and young people who immigrated as part of the Children and Youth Aliyah, or as young adults on the Hechalutz program. Most of these devoted their lives and their future plans to the kibbutzim or later settled in "moshavim"<sup>87</sup> (cf. Pinner 1972) and thus embodied the image of the new Israeli, the Haluzim. But because of the cliché of the German Jew, these adolescents and young adults were under considerable social pressure, both on their kibbutzim and in their social lives in general, to constantly prove through their lifestyle and their approach to life that they did not conform to this cliché, but rather, were upstanding Zionists - in the sense of Zionism as "salvation" and not as "deliverance" (cf. Segev 1995) - and that as pioneers or Haluzim they were helping to build new agriculturally-oriented settlements.

### The family dialogue: Our commitment to Israel

The overall finding of our study is that both the family dialogue and the biographical constructions of the individual family members in families, whose grandparents managed to emigrate from Germany before 1939, are defined by other themes than families of survivors of the Shoah. In families of survivors, the operative themes are "death" and "fear of annihilation", whereas the family and life stories of the families of forced emigrants, whether they now live in Israel, or West Germany or the former GDR, revolve around the themes of

---

85 A Hebrew term for resettlement. On the basis of the Haavara agreement of August 1933, emigrants were allowed to take with them some 15,000 Reichsmark (1000 pounds sterling) in foreign currency and goods valuing 20,000 Reichsmark. 1000 pounds sterling was required to get a so-called capitalist visa from the British. For details of the Haavara transfer, see Feilchenfeld (1972).

86 Nearly half of the immigrants from Germany were over 30 years old and had entered the country on a capitalist visa (Beling, 1967, p. 87). Cf. the case study by Fischer-Rosenthal (1996).

87 A kibbutz is a collective and a moshav a cooperative settlement of small individual farms.

"emigration" and "life in the new society". In Israel, in contrast to Germany, it becomes apparent that the children of young forced emigrants tend to block out the theme of "emigration", because unlike the second generation of Holocaust survivors, they want to present themselves as Sabres, as Israelis without European roots. Instead, the life stories of members of this generational unit revolve around the realization of Zionist ideals (through a strong bond to the kibbutz or a Zionist life in Israel, among other things). On the other hand, they reject the German past of their parents and with it their own European family history, playing down their significance. It is only the third generation that is now beginning to deal with the emigrant fate of their grandparents and to get in touch with their latent but still tangible longing for Europe/Germany<sup>88</sup>.

Let us concentrate now in detail on three generation families with grandparents who were born between 1918 and 1924 and who came to Israel with the Zionist Youth Aliyah, either directly or through third countries. We refer to the generational unit of the grandparents as the "Youth Aliyah generation", as it became very clear in the course of interviews with them, how much their vital sense and their life story were permeated by their emigration as part of the Youth Aliyah or Hechalutz when they were adolescents, as well as by the Zionist orientation initially imposed on them by National Socialism. It is striking that, unlike older German forced emigrants, young forced emigrants felt a much stronger commitment to a Zionist way of life on the kibbutz. If they did end up leaving the kibbutz after deep moral conflicts, they tended to opt for a life oriented on agriculture in small towns and settlements, such as in the Negev desert for instance, or along the Dead Sea, rather than permitting themselves to give in to their longing for a cultural life in the city. Unlike many older German forced emigrants, the biographical constellation in their youth led to the Zionist way of life they had initially chosen to save themselves turning into a life devoted to the state of Israel, and to them developing a decidedly Zionist stance in the sense of a Zionism of "salvation".

The members of this generational unit see themselves in their manifest self-definition as conspicuously separate from the Shoah. Although their parents and other reference individuals were persecuted and murdered, they try not to present themselves in this family history context. In our interviews with them, it struck us again and again what pains they took to separate their own life from the Shoah. It was not a rare occurrence for them to only speak of the murder of their relatives in response to being asked about it by the interviewers. In their attempt to separate their own life from their family history, they demonstrate a strategy of dealing with a threatening family past which we find with children of survivors. But whereas members of the "Youth Aliyah gen-

---

88 Families from the former GDR, on the other hand, incorporated the theme of "emigration" into the socialist self-comprehension of all three generations, as emigration either began or continued their grandparents' "anti-fascist" path through life (cf. Chapter 4).



eration" are able to tell their life story in Israel (particularly along the thematic lines of "Zionism" and "life on the kibbutz"), children of survivors experience something akin to a block when it comes to establishing a life story of their own, independent of the theme of the Holocaust (cf. Moore 1994). In interviews with children of survivors, their suffering on account of their parents' persecution is clearly manifest as a theme, in both individual interviews and in family interviews as well, whereas children of murdered parents tend to avoid this theme. This difference is also apparent in later generations. For example, the children and grandchildren of the Youth Aliyah generation know a great deal less about who was murdered in their family than the children and grandchildren of survivors.

However, interviews with forced emigrants show clearly how much their family history is a cause of suffering for them, but also that they cannot admit to this suffering. Instead, more or less manifest expressions of their guilt feelings about their emigration pervade their biographical self-presentation. They reproach themselves for having had to leave their parents, relatives and friends in Europe and for not having recognized the dangers those they left behind were exposed to. Their feelings of guilt for having survived are specifically linked to the time when their parents were still alive in Europe. Often, they managed to tell their children of their persecution or write letters asking for help for their own emigration. This guilt is the result of their own helplessness at the time and the fact that it was too much for them to have to adjust to life in a foreign country on one hand, and feel responsible for their parents and siblings in Germany, on the other. At the time, many of these young adults were occupied with starting families of their own and creating a future and a new home for themselves. In retrospect, this biographical constellation weighs very heavily on them. To stop these self-reproaches from gaining the upper hand, many of them in their biographical constructions try to separate their life after emigration from their life in Germany<sup>89</sup>. As we will show using the example of the Arad family, others basically avoid talking about their life before emigration and about their family of origin.

Let us get a sense of the situation of young forced emigrants in the period from 1945 to the founding of the state of Israel. They lived in existential and political insecurity: Will there be a state of Israel or will the Arab states drive the Jews out again or even destroy them? How many Jews will the British prevent from entering the country? What is happening in Europe to the relatives and friends they left behind? These uncertainties were part of their lives, but they did not want to be overwhelmed by them. Thus, particularly during this time, they tried to suppress doubts about whether their relatives would be saved and tried to avoid a realization of the crimes that were being committed during this period. In their interviews they emphasize how as young Zionists

---

89 Cf. the case analysis in Rosenthal (1995a), Chapter 4.4.4.

and kibbutzniks they tried to look into the future with optimism and certainty. By working to build up Eretz Israel, they sought to do justice to the duty inherent in their being chosen for the Youth Aliyah. They wanted to help a Jewish state flourish, wanted to be Israelis and to forget their German past. We believe, however, that the optimism of this period and their dismissal of news from Europe are overemphasized in present-day interviews because of their guilt feelings. As Mr. Jarkoni's statement quoted at the beginning of this chapter indicates, these were difficult years in which these young people had to make a great effort to fulfil social expectations. They were hardly able to show their longing for home and for their parents openly, but concern for their parents and relatives was part of their daily lives.

In the 1940s and 1950s in Eretz Israel, "a youth without parents" was a socially operative myth of the new Israeli, who renounced European family tradition, loved working in the fields, was physically healthy and above all tried to distance him- or herself from the image of the inferior Jew from Eastern Europe (cf. Rubinstein 1977). The effectiveness of this myth was due, among other things, to the fact that it corresponded both to the reality of life of young people living on kibbutzim in the 30s and 40s, and to the needs of the adolescents, who were trying to separate from their families and who wanted to lead their own lives. However, this kind of sense of self, of having no past and no parents, entails the risk for young people of them getting stuck in adolescent conflicts in later life (Rubinstein 1997). In the case of members of the Youth Aliyah generation, this risk was heightened by the fact that they were confronted with the murder of their parents after World War II, which virtually froze their separation-individuation process, or blocked them from dealing with the family relationships they had experienced before emigration.

Against this background, they were unable to take in the full significance of the news that members of their family were dead, news which generally reached them after 1945, and which was linked to the collective fate of the Jewish population of Europe, the murder of six million Jews. Their grief at this loss was more or less suppressed, and this comes across in interviews with members of this generational unit. Because they feel guilty for having left their families and then not helped them, they are still very attached to their parents today. It is precisely these guilt feelings which prevent this generation, separated from their parents in mid-adolescence, from mourning the loss of their parents and thus loosening their bonds to them. They cannot permit themselves to think about their parents critically, but rather feel an obligation to present their family and their childhood as a whole in an exclusively positive light. The need to present their family in an extremely positive light is a structural similarity common to all those who were forced to emigrate as young people and had to leave their parents behind. We assume that suppressed grief at the death of their parents has had a considerable impact on the relationship this generation has to their own children. Not only that this

suppressed grief was unconsciously transmitted to their children; it can also be assumed that because this suppression meant that they were only partially able to loosen their bond to their own parents, that this will have interfered with their own relationships to their children.

With the realization, that members of their family had been murdered, and the awareness of the extent of the crimes, the relative lack of concern about events in Europe became a problem for this generational unit, as it did for all other Jews living outside of Europe. In Israel, this problem was clearly reflected in the public discourse about the Shoah. In Palestine between 1933 and 1945, the Jewish population was concerned with fighting to create the future state against the British mandate, as well as with building up state structures: the fate of the Jewish population in Europe was not a central issue in public discourse at this time. If anything, to a certain extent the mass media protected the population from realizing the cruel reality of the Holocaust, by reporting the Holocaust in the past tense and cladding information about persecution in Europe "in Biblical laments and poetic mottos": "in this way the press distanced the Holocaust from everyday life and absolved their readers from the duty of seeing it as part of reality" (Segev 1995, p. 145). This attitude, as well as the failed and abandoned assistance measures which became more public after the Second World War, led to a collective sense of guilt, which resulted in the institutionalization of a collective silence. It was not until the Eichmann trial in 1961 that this silence was broken, leading in Israel to a dramatic transformation of the relationship to the Holocaust. The trial was broadcast on radio, and many testimonies by survivors of the Shoah were transmitted. As a result, their suffering began to become a public issue which attracted considerable attention (Danieli 1980; Segev 1995).

The way young forced emigrants deal with the Shoah corresponds much more to the public Israeli justification discourse than to the reflections of Holocaust survivors. Whereas survivors tend to torment themselves with questions of their own individual guilt, forced emigrants tend to argue on a collective level and exonerate their generational unit as a whole and the Yishuv as well. Thus, for instance, they speak of how Palestine as a mandated territory without an army could have done nothing against the Nazis.

What is striking in our interviews with members of the Youth Aliyah generation is their strong Zionist orientation and their commitment to the kibbutz movement. In stark contrast to older German forced emigrants, as well as survivors of the Shoah, members of this generation make a greater effort to deny their connection to Germany or Europe, and, to present themselves as Sabres in their manner. Whereas, in some cases, older emigrants have still hardly learned any Hebrew, still talk about the good old days in Europe, are completely dismissive of the oriental way of life in their country, and have hardly changed their eating habits, the Youth Aliyah generation identify with their immigration country. Many of them even refused to speak German for a

long time. The analysis of the interviews shows that living for Zionism and taking an active part in building up Israel are among the things that help ease their tormenting guilt feelings about their murdered relatives. They can give a meaning to having left their family by legitimizing it through the necessity to live and work for a Jewish state. However, doing so means they have to play down the significance of their painful experiences in Israel and on the kibbutz. They are bound to their positive identification with the Zionist way of life on the kibbutz or with a life devoted to the Israeli collective community. This mechanism is comparable with that observed in young forced emigrants who joined the emigration to the West of the Communist Party before 1945 and returned after the founding of the GDR to lead a life there oriented on Socialism (cf. Chapter 4).

However, our interviews in Israel also show that, in line with the public discourse over the past ten or fifteen years, the Youth Aliyah generation has gradually and reluctantly begun to deal with their life before Palestine and with their repressed longings. They are travelling to Germany and Europe, visiting their home towns and the buildings they lived in as children, and are writing their life stories and cultivating contacts to Germans. As we will illustrate using the example of the Arad family, this changing attitude to Germany and the Germans has consequences for family dynamics.

The second generation, which has always rejected their parents' latent but tangible longing for Europe, is having considerable problems with the fact that their bond to Germany is becoming manifest and that they are beginning to work through their grief. This generational unit was born roughly between 1943 and 1957 and belongs to the generation of the first Sabres after the Holocaust. In line with public discourse, they received the delegation from their parents to live for the future of Israel and not to look into the past. With their parents beginning to work through grief and loss, they themselves are for the first time confronted with, and made aware of, the fact that their image of belonging to a family untouched by the Holocaust does not tally with their family history. This makes them realize that they themselves belong to the third generation of Holocaust victims because their grandparents did not survive the camps. Linguistically, this awareness becomes manifest in their gradually beginning to speak of "my grandparents" and no longer of "my parents' parents".

But what comes across in interviews even more strongly is how, just like their parents, they avoid the theme of the part of their family history that is linked to the Shoah. This is why it is difficult for them to get a perspective on their parents and their guilt feelings. In order to not be threatened by their parents' problems themselves, they block out empathy with their parents, and instead accuse them of having a European way of life or lacking an Israel approach. This generation conflict is particularly exacerbated by the fact that the children of the Youth Aliyah generation can hardly measure up to their

ego ideals which are oriented on their parents. Many of the members of the Youth Aliyah generation took part in the illegal fight against the British before 1948 and were involved in illegal entry into the country. Many fought in the War of Independence from 1948-1949 and since their Aliyah have worked hard to make the land fertile, with no consideration for the professional careers they had begun or planned in Europe. Their children were faced with the problem of trying to emulate heroes, something they could hardly manage in the changed living circumstances in Israel. There were literally hardly any stones left for them to move aside and the days of living in tents were over. The positively loaded image their parents presented them with of "a youth without parents" did not match their reality. The next generation could no longer experience this "orphan existence". In the eyes of the second generation of the Youth Aliyah generation, their parents were therefore inaccessible heroes, without whom the country would not have begun to flourish. They could no longer be the pioneers their parents had been. Thus, their image of being Sabres (Israelis born in the country with their parents, but without German or Yekke socialization), which disassociated them from their parents (pioneers with German/Yekke habitus), became a crucial part of their identity. This image also helped them to repair their unfulfilled ego ideal. As "Sabres", they are in opposition to their "European" parents and attack them for everything they themselves interpret as a European way of life or disposition. It is not rare for this to be expressed in a very emotionally loaded anti-German stance.

We could at this point assume that this characterization of the second generation is specifically true of the age-groups born between 1943 and 1953, who were the first generation of European Jews born shortly before the state was founded or in Israel. However, if one contrasts the life stories of children of forced emigrants with those of children of survivors of the Shoah in the same age-groups, clear differences emerge. But let us look first at the similarities: these age-groups experienced their childhood in the shadow of two wars, the Second World War in Europe and the War of Independence in Israel. As children, they experienced the founding of the state of Israel and the victory of the War of Independence. Both wars resulted in many victims, but were also a prerequisite for the creation of the state of Israel. After the suffering in Europe, this generation was able to identify with the first Jewish state. They grew up in a period in which active struggle was emphasized in disassociation from the passive suffering of the persecuted Jews in the Holocaust. This gave them the opportunity to identify with the image of the Israeli who lives and fights actively for his country. But whereas the Youth Aliyah generation and their children identified with a "Zionism as a collective duty", for the families of survivors of the Shoah, Zionism meant "protection" to a much greater extent. Whereas the children of forced emigrants oriented themselves far more on the collective ideal of the state and its preservation, the life of the

children of survivors, sometimes contrary to their intention and self-definition, revolved far more around caring for their parents. Whereas in their life stories, the children of forced emigrants present themselves as Sabres with their own life histories, the children of survivors find it hard to portray their lives independently from their parents' suffering.

A comparison of both generational units illustrates that the children born in these years as a generation are defined by a childhood characterized by the impression of losses and of fighting in both wars. This gives both children of survivors and children of forced emigrants the feeling that their own individual life stands in the shadow of these events. But whereas with children of survivors, their own life is in the shadow of the past persecution of their parents and the Shoah in general, for children of young forced emigrants, this pales in significance in the face of the great duty of working together to establish and strengthen the Israeli state. The life stories of the latter differ in that they are closely interwoven with the history of the creation of the Israeli state. They emphasize the present in their life stories. They can hardly comprehend their parents' interest in their European countries of origin, especially Germany, considering that they have learned that the consequence of a long history of persecution with the Shoah as its most extreme manifestation can only be a life lived according to Zionist ideals. And to this generation, being a Zionist means orienting their lives on Zionist collective within a developing Israeli society.

This difference between children of survivors and children of forced emigrants in the way they present their own family history generally emerges in the first sentences of the biographical self-portrayal. Thus children of forced emigrants begin talking about themselves without rooting themselves in their family history. A typical beginning goes like this: *"I was born in kibbutz M. in 1950, when I was six years old we moved to Dimona, where I went to school. And my most vivid memories of my childhood are of the trips we went on, of sleeping in tents. I was active in the youth movement"*. In contrast, the daughter of a survivor<sup>90</sup> tends to begin in the following way: *"My mother's entire family died in the Holocaust...We had a clothing factory in Slovakia..."* The difference in the linguistic microstructure becomes apparent in the way she begins her life story. When she mentions her grandfather's clothing factory, the autobiographical narrator - or biographer - speaks in the plural and thus becomes part of her family history herself. In contrast, in the beginning of the interview with the son of a forced emigrant quoted above, the parents do not feature as characters, nor is the family history a theme. The biographer presents himself as Sabra, born in Israel, whose childhood was mainly defined by trips with other children.

---

90 Cf. the case study of the Steinberg/Noifeld family in Rosenthal u.a. 1994, p. 124ff.

In contrast to the children of survivors, this generational unit of "Zionism as a collective delegation" appears less bound to their parents and their family history on a manifest level. Their life histories demonstrate a much stronger bond to Zionist ideals or to the kibbutz or the state of Israel. However, we assume that this bond - as in the case of their parents before them - is based on an unconscious or suppressed bond to their parents and the fact that they have failed to loosen this tie. Because they have not separated from their parents, but rather have transferred their loyalty obligations to the kibbutz or the state, they feel bound to the kibbutz or to Israel even though some of them long for a life elsewhere. It is not rare for their children, born approximately between 1969 and 1975, to act out these longings.

The grandsons and granddaughters of the Youth Aliyah generation were born between the end of the 60s and the beginning of the 80s. This is a generation born after the Six Day War in 1967 into a greater and more powerful Israel than their parents, but one that, as children, had to then go through the shock and grief of the Yom Kippur War in 1973. This war, which came fully unexpectedly for the Israelis, the attack by the Egyptian and Syrian army on the Day of Atonement (Yom Kippur), and the high number of casualties<sup>91</sup> reactivated a deeply-rooted fear of annihilation and once and for all destroyed the myth of invincibility (cf. Segev 1995, p. 517ff.). The generation of grandchildren was therefore socialized at a time when Israeli society was shaken in its self-assuredness, in its illusion of indomitability. Malkinson and Witztum (1993) speak in this connection of a turning point from private to public grieving. With the gradual begin of public work of mourning came a movement away from focusing on resistance, and the victims, who had previously been accused and reproached with having gone like "sheep to the slaughter", became people one could identify with. The turning point which had begun became increasingly more manifest, partially as a result of the Lebanon War (1982) and the pain people felt at the ensuing deaths, particularly parents who had lost sons, became a public issue. This also had a considerable impact on educational work with young people. From 1984 on, trips to the memorials of extermination camps in Poland were made available to young people, initially organized by the kibbutzim; since 1988, the Ministry for Education has taken on this program and provides state funding for it (cf. Feldman 1995). The young people often came back with many questions that they asked their grandparents, by doing so, opening a family dialogue<sup>92</sup>. Another activity initiated by the kibbutzim since the 70s is that thirteen-year-old boys and girls are instructed to write "roots papers", family histories based on interviews with their grandparents or other family members. It is often only through this re-

---

91 "There were 2500 deaths to mourn, every thousandth Israeli citizen. Only in the War of Independence had more people fallen in battle". (Segev 1995, p. 518)

92 Based on interviews with young people, Dan Bar-On (1992) writes in this connection that trips which included family members had a far greater effect in opening the dialogue.

search of the children that the parents find out about the grandparents' past (cf. Bar-On 1995, p. 32).

The change in the way Israeli society deals with the Shoah and in the Israeli myths and values related to this, as well as the specific impact on educational work this change has had, mean that the generation of the grandsons and granddaughters was socialized to have a different relationship with the first generation. They pay more attention to the traumas, longings and European past of their grandparents. But despite this, in interviews with us, the grandsons and granddaughters of the Youth Aliyah generation emphasize the immigration and the building up of the kibbutz or the state of Israel and minimize the family past in the Holocaust in their version of their family history. For their parents, they are a symbol of continuity of life on the kibbutz or in Israel. If they leave the country or the kibbutz, their parents' generation which fought in all the wars for Israel or built up the kibbutz, which lived to create stable living conditions and to realize Zionist ideas, often feel they have failed.

Again and again in families, we find that it is precisely the second generation that puts considerable pressure on their children to make them stay in Israel or on the kibbutz for ideological reasons. Thus, for example, one of the fathers we interviewed in the family sculpture said to his son: *"I want you to stay on the kibbutz, not for yourself, but for society"*. The father anticipated his son's answer as follows: *"Yes father, I know you are right"*.



## 11. A love-hate relationship with Germany: The Arad family

Gabriele Rosenthal, Bettina Völter and Noga Gilad

The Arad family grandfather (Aharon Arad, born in 1920) as well as grandmother (Dorit Arad, born in 1922) were born and raised in Germany. As young people, they emigrated to Palestine shortly before the start of World War II. The Arads, who have always lived on a kibbutz, have a daughter (born in 1943) and three sons (born between 1945 and 1957). None of the four Arad children married spouses of Western European background. The two oldest ones are or were married to spouses of oriental background. The middle son married the daughter of early Eastern European immigrants and the youngest one, Dror, married an American gentile. While the sons left the kibbutz and the youngest of them emigrated to the United States, the daughter still lives on the same kibbutz as the parents, where she has raised four children. Dror's leaving Israel has been a great disappointment to the entire family; his father and sister, in particular, consider it "treason against Zionism." His mother takes it more calmly, saying she doesn't accuse him as "we, too, would have left the nest, even without Hitler."

Taking an overall view, the dialogue with the family is largely determined by the themes of "rejection of Germany" and "Zionism." Until this day, extremely strong, ambivalent feelings bind Aharon and Dorit to Germany. Interviews with the second and third generation reveal that the children and grandchildren, too, have to protect themselves from these ambivalent feelings. On the manifest level, they adopt an aggressive, negative attitude toward Germany and the Germans, but because of the family's history, they have the same ambivalent ties. This dynamic also determines the interaction with the German non-Jewish interviewers, Gabriele Rosenthal and Bettina Völter. Both are members of the generation whose grandparents lived as adults in National Socialist Germany.

In the following pages, we present an analysis of the biographical and familial constitution of this dialogue. This is based on our interviews with both grandparents, the daughter Paz, the son Josef (b.1950), as well as with the oldest granddaughter Galit (b.1967), the daughter of Paz. In addition, we elaborate on two conversations with the family. In the first one, Dorit and Aharon Arad, as well as daughter Paz Israeli participated; in the second, which took place a year later, the grandparents and their granddaughter Galit took part.

The emigration experiences of Aharon and Dorit were very similar. In response to National Socialist racial policies, both became members of a Zion-

ist youth organization in the 1930s. In the spring of 1939, both succeeded in emigrating to Palestine. Shortly thereafter, they met each other and married. In 1936, at the age of sixteen, Aharon had already left his family to go to Holland, to prepare himself for the emigration. For Dorit, the separation from her family came in 1939, when she travelled directly to Palestine. Forced separation from their families took place in mid-adolescence, that is, at a time when the process of forming an autonomous personality, the process of individuation and separation, had begun but had not yet been completed. This is a typical structural criterion which continues to define Aharon and Dorit's grief over the loss of their parents. Both feel guilty that they did not write to their parents more often from Palestine, and both are tormented by the thought that they should have done more to save their parents and siblings. Their marriage, too, can be understood in the context of the forced separation from their parents. One may assume, from the reconstruction of their narrated life stories, that by forming their own family they tried to find a substitute for the families in which they had grown up, and at the same time prove their own personal autonomy. As is the case in other marriages of this constellation, Aharon's and Dorit's marriage is burdened by very high expectations, with the partners serving more or less as substitutes for their lost parents.

Forced emigration during mid-adolescence caused a further problem for Aharon and Dorit. Both had done well as students in highly-rated high schools and, in effect, had planned to continue their education at a university. When they first emigrated, they had hoped to return to their families, once the war was over and to embark on academic careers. The murder of their parents in the Shoah also destroyed this future plan. Aharon and Dorit have suffered all their lives from the loss of status brought about by their emigration.

Beyond the similarities in Aharon's and Dorit's life histories, and beyond the constellation that strengthened their marriage, one finds, however, differences in their socialization at home. Let us look first at Dorit Arad's life up to the time of emigration. Dorit was born in 1922, the first child of a Northern German Sephardic merchant family that was highly respected and proud of its tradition; she was already seven years old when her brother was born. The parents expected great accomplishments from their daughter, and Dorit always tried to live up to their expectations. Particularly after 1933, she spared no effort to be the best student in her class, being Jewish. In 1936, she had to leave high school and transferred to a Jewish Orthodox school. There she became a member of a Zionist youth group and within the framework of the Youth Aliyah began a retraining program in 1938. She stated the opinion of her parents as follows: *"Let her go; two years of Youth Aliyah are not too bad; that's two years; then she will return and get a proper education; it'll have lost its charm by then."*

The family saw the war coming but, prior to the pogrom of November 1938, they could not imagine that German Jews might face the threat of

planned extermination. Based on his own experience during World War I, Dorit's father hoped that German Jews would be drafted again to fight as soldiers in World War II<sup>93</sup>, and that anti-Semitism would only be a passing phase at the beginning of the National Socialist era: *"Pogroms took place in Poland but not here.... You thought Hitler would remember during the war that there were some more people who he might send to the front lines, just as long ago the emperor had issued an important decree 'To my dear Jews!'"*

It was not until after the November pogroms in 1938 that Dorit's family started thinking of emigrating. But only Dorit managed to escape from Germany in the spring of 1939; her parents and probably her younger brother, too, were killed. Dorit tries to avoid this subject. Upon Dorit's request, Gabriele Rosenthal interviewed her in 1990. This was the first conversation in which Dorit spoke of her life prior to her Aliyah and the murder of her parents. She emphasized that until then, she had tried to avoid thinking of her life in Germany and the murder of her family. She also argued that: *"My life prior to coming to Israel is gone forever; it's finished and has nothing to do with my life here."*

Nevertheless, some events, like the farewell from her parents, have haunted Dorit her entire life; but she had never talked about them with anybody before.

In 1939, Dorit first went to a kibbutz near the Syrian and Lebanese border. That is where she met Aharon, whom she married in 1941. On the whole, this was a time of great hardship but Dorit remembers how much she enjoyed life on the kibbutz during that period of building a new society. As she describes it, the beginning of the war put an end to contact with her family: *"Once the war started everything was over."* Dorit talks of her feelings of guilt, and about the fact that she at the time had hardly thought about the situation in which her parents and brother found themselves. She argues that it would have been better to have served in the British army, fighting against Germany, and to have waited a few years before having children. She mentions her guilt feelings, particularly concerning her brother. She is tormented by the thought that in those days, she considered her brother a burden and did not do enough for him. She adds, finally, that even after the start of the war, she received a twenty-five word letter from her parents but does not mention its contents. This last letter, written probably at a time when they were already in a ghetto or camp, represents for Dorit the turning point in the story that ended in her parents' murder. Her husband reported in his interview that this letter to his wife arrived after he and Dorit had married. In it, his parents-in-

---

93 It is not impossible that the Armed Forces and the High Command considered drafting Jews. When the General Defense Law (Wehrgesetz) of 1935 came into effect it stipulated that Jews could not be called into active service; but they, too, were subject to military mustering. Even after the outbreak of the war, this muster continued (cf. Ball-Kaduri 1964).

law inquired about his social and family background. Dorit reveals in an indirect way how this inquiry might have been a problem for her. She argues that her husband's family had been very religious, a background to which her parents strongly objected. According to Dorit, her parents kept their distance from religious and, particularly, Eastern European Jews<sup>94</sup>. For instance, they made sure that their children spoke German without any Yiddish colouring. Her father had become very upset once, when she used the term 'nebbish.' Here, Dorit's evaluation of her parents' attitude borders on the aggressive: "*Had it not been for the matter of anti-Semitism, my parents would have been good Nazis*". This statement exemplifies how feelings of disappointment and rage against her parents, which Dorit otherwise had to suppress, find indirect expression in this and other parts of the interview.

Dorit was able to find out that her parents and brother had been deported to a concentration camp in Poland. For many years, she had hoped that they had survived. Until this day, she is unable to accept the reality of her brother's death. Over and over she imagines finding him again; she goes through German, Dutch, and other countries' address books, dreaming that she finds his name, adorned with a preceding 'Herr Professor'. She visualizes the death of her parents; she imagines that her father was either killed fighting in the Warsaw ghetto uprising or shot trying to escape. Concerning her mother, she thinks, however, "*I am sure she did not resist.*"

While Dorit Arad is trying her best not to grasp the true significance of the Shoah for her family, her husband, as he gets older, makes increasing attempts to do so. Aharon Arad was born in Berlin in 1920; his sister was five years older. His mother was raised in a traditional Sephardic family in Danzig. Aharon insists: "*not a Danzig Pole, a true Danzig native.*" His father came from the province of Posen, "*the crucible*' of German Jewry", he explains in narrating his life history. His father was an employee of the Berlin Jewish Community. His parents were modern, enlightened reform Jews who kept their distance from orthodox Eastern European Jews: "*At home speaking*

---

94 Aharon Arad's parents considered themselves German Jews from West Prussia and wanted to be distinguished from Eastern European Jewish immigrants. But in the eyes of Jewish families in the Western part of Germany - like Dorit's family - they already were "Eastern Jews." Hermann Zondek, a physician born in Posen (Polish=Poznan), which formed part of Prussia from the eighteenth century until World War I, who had come to Berlin around the verge of the century, remembers that by no means was there a consensus about who should be considered an 'Eastern European Jew': "In the eyes of Jews who were proud to have been germanized, the geographical definition of this concept depended on the area they lived in. For Jews from Frankfurt on the Main, the demarcation line was the Elbe river; Jews from Berlin pushed that line further east to the Oder river. But there could be no doubt that Jews from the other side of the Warthe river were Eastern European Jews. Jews from "Congress Poland" (the area carved up in 1815-1818 at the Congress of Vienna between Austria, Russia, and Germany) were considered members of a more or less foreign race while we, residents of the German province of Poznan, enjoyed the status of mestizos." (Zondek 1973, p. 33f).

*German with a Yiddish accent - we called it "mauscheln"- was prohibited. It was considered the language of the gutter."* We may assume that Aharon Arad's parents belonged to the group of Berlin Jews who had come there at the beginning of the century or had migrated there when, as a result of World War I, Poznan and Western Prussia had to be transferred to Poland<sup>95</sup>. They considered themselves German Jews, in order to stress the difference between themselves and the Eastern European Jews, the great majority of whom had come to Berlin from Russia, Poland, and Galicia<sup>96</sup>.

German Jewish young people who, like Aharon, had grown up in homes, where this attitude prevailed, encountered exactly the opposite status relationship upon their arrival in Palestine. In those days all leading positions in Palestine were occupied by Eastern European Jews. Until then, their German upbringing had involved distance from Eastern European Jews; now suddenly they found themselves in a world where these values had been turned upside-down. This constellation in their life history certainly contributed to their attitude toward their German-Jewish background. Aharon presents himself in the interview, half jokingly, half ironically, as a person who before his life in Palestine was a blue-eyed, blond German bearing the name of Ludwig Schwarz. His need becomes obvious to present himself simultaneously as a German, who is Jewish, and as a Jew, who wants to have nothing to do with Germany:

*"If you want to know my personal attitude to Germany (1) in one word it's love-hate (2) love hate ... I can't tear myself away from what is German... as said, my thoughts are German... my (2) culture is German...but (5) it becomes again (2) very, very difficult to establish a normal relationship to Germans".*

These ambivalent feelings determine the tone of every encounter in which the German interviewers participate. On one hand, Aharon wishes to be interviewed by Germans and in these conversations tells them of feelings which, as he claims, the Israelis around him do not understand. To give an illustration of this, he describes the feelings he still has today, of sitting with his bags

---

95 The Jewish population of Greater Berlin amounted to 144,000 before the start of World War I (1910) or 4,0 percent of the city's inhabitants. There were 173,000 Jews in Berlin in 1925 or 4,3 percent of the city's inhabitants. (Richarz 1988, p. 179).

96 "Jews of Eastern European background usually lived in certain Berlin neighborhoods while Jews of Western European background usually resided elsewhere. This East-West differentiation had a 'social status' as well as a one of "geographic area of origin". In Berlin "Eastern European" and "Western European" Jew were concepts that had to do less with the geographic origin of a person than with the period in his or her life history. It occurred frequently that Jews who had recently come from Eastern Europe established themselves first in the above-mentioned neighborhoods. But as they gradually became more well-off they moved into the more elegant Bellevue neighborhood where the upper middle class resided. As they reached further heights on the social ladder they established residence in Charlottenburg and thus became Western European Jews". (Gronemann, 1979, p. 406ff.)

packed and waiting for his parents to ask him to return to Germany. He also vents his disappointment that none of his children and grandchildren have read his biographical notes. On the other hand, he clearly distances himself from the Germany of the nineties. The introductory phase of his first interview with Bettina Völter and Gabriele Rosenthal deals with the attacks against hostels for foreigners seeking political asylum in Germany and with anti-Semitic violence. Aharon explains that *"we want to forget...we want to open a new page in the book (I) recently we have been able to see this without feeling that much involved"*. The case of Aharon Arad and his wife Dorit illustrates how extremely negative feelings, of many years standing, against Germans and Germany may diminish with advancing age and in changed surroundings. Since 1971, the couple has made several official and personal trips to Germany. On every visit, however, the neo-Nazi movement and racism have renewed their scepticism.

For Aharon, the central interview theme is his relationship to Germany, to German culture, and to Germans. He describes these ties to his country of origin as extremely strong. But these very ties cause him great problems by repeatedly reactivating his aggression against the Germans as perpetrators. As he formulates it in a number of conversations: *"I hate myself because I cannot hate the Germans."* His ambivalent feelings and auto-aggression become even more understandable if we bear his family history in mind. For Aharon's parents, it was a given fact that they were German, and despite the all-pervasive threats of the mid-thirties, they could not make the decision to emigrate<sup>97</sup>: *"My father was of the generation that said "This will pass. I was a combat soldier, I received the EK II medal"* (the Iron Cross Second Class, a military medal awarded only to soldiers who had demonstrated extraordinary valour in battle).

We have to take into consideration that families of soldiers, who had fought at the front line during World War I, enjoyed certain privileges in the early years of the Hitler regime. For instance, the restricted entry imposed on Jewish schoolchildren and university students did not apply to the children of these soldiers for a while. By wishfully believing that the non-Jewish German collective saw them in a different light from other Jews, Aharon's parents, like many others, tried to interpret the daily encounter with anti-Semitism and persecution as a transitory phenomenon. But until this had passed, they thought it fitting that their son left the country.

Aharon joined the Zionist youth organization *Jugendbund*. In 1936, it was his good fortune to be selected for entry into a "Hechaluz" centre in Hol-

---

97 The great majority of the Berlin Jewish bourgeoisie were liberal and firmly rooted in the tradition of German higher education; its members considered the National Socialist regime and the excesses of its first weeks a passing phase. The Berlin Jewish community assured Hitler as late as March/April of 1933 of its identification with the German people and its willingness to cooperate in Germany's reconstruction (Ehmann, 1988, p. 245ff).

land. There, 50 young people with German passports were trained for agricultural Aliyah. Aharon returned to Berlin once to celebrate the 1937 high holidays with his family. His father cried copiously when he left: *"I did not understand (I) for two weeks that they had put on an act."* Mr. Arad reproaches himself bitterly that he did not take the situation seriously enough. He had no inkling that he would never see his parents again. To this day, Aharon Arad is haunted by the fact that he wrote his parents only a few times after he had arrived in Palestine. Stamps were rationed on the kibbutz. At another point in the interview, it becomes clear that his interest in Germany and in the family he had left behind also diminished because he had to use all his strength to adjust to a new situation: *"We arrived here (I) there were no parents (I) our group was dispersed over the entire country (I) the surroundings were completely strange to us (I) we tried to 'belong' (I) we were forced to try to establish a new family"*.

During the first years in Palestine, the Arad couple moved from one kibbutz to another. Their life was one of constant menace from the Arab states, hard work, poverty, and hunger. During this, Aharon Arad received mail from his sister in a French internment camp. She urgently asked him for food: *"We did not have anything to eat ourselves (I) at that time we lived on an urban kibbutz; there was no milk for the kids, no bread, no flour (I) we went begging from those who had nothing themselves."*

The interview clearly shows that for Mr. Arad, building a new country and life on a kibbutz is closely tied to the Shoah. The extreme deprivation he suffered in Palestine during these years made it more difficult for him to see his family's perspective in Germany. Thus, the grandfather's, Aharon Arad's, history especially binds him to the kibbutz that he invested so much energy in building up.

In the interview, he tells us that with advancing age, he dreams ever more frequently of his parents' fate. A recurring dream he has is that he finds himself in a moving train. The older he gets, the more vividly he imagines his family's sufferings. In 1945, when they first heard of the murder of six million, they simply *"could not grasp it."* Not until the end of the 1980s did Mr. Arad find out through painstaking research what happened to his parents and his sister. In an archive, he found the notice that his sister was considered "missing." He fantasizes that she starved to death in the camp or was deported from there. Her child was deported from a children's home and murdered. Exact information about the fate of his parents exists. They were taken to Theresienstadt in 1943 and were deported from there to Auschwitz more than a year later. The thought that they could have been saved a few months later, makes him utterly despondent. His parents' last postcard reached him in 1942. It said *"Dear Ludwig, we shall be travelling. Stick together. Wish descendants"*. Aharon hopes that his parents received the news of Dorit's pregnancy. His oldest daughter, Paz, was born in 1943. Her birth occurred at a time when

the family Arad no longer received news from Germany and had to fear the worst about their kin there.

Paz Israeli (née Arad) was born in 1943, during World War II, the first child of Dorit and Aharon. We may assume that her parents associate her much more with the Shoah than her siblings. Both of her parents mention this.

Let us look first at the life history of Paz. The family moved several times while she was a small child. She was five years old when her parents settled with her and her three-year-old brother on the kibbutz where she and her parents still live today. This was during the War of Independence. The kibbutz had been established only two years earlier, which makes the Arads members of the pioneer generation. As a child, Paz thus experienced the foundation of the state of Israel and the War of Independence as events related to the establishing of her home. Like all Israeli women, Paz did two years of military service, starting at the age of eighteen. There she met her future husband, Oren Israel, who is of oriental background and like her was raised on a kibbutz. Oren was brought up in a Zionist family that had come to Israel when he was seven years old. Shortly after Paz finished her military service, she married Oren and he moved to her kibbutz. Paz works there as a kindergarten teacher, as well as in other educational areas; one of her jobs was giving language lessons to recent immigrants. She and her husband have four children. Now, after 28 years of marriage, she is divorced.

Paz absolutely refused to talk to a German interviewer, so she was interviewed by Tamar Zilberman, our Israeli colleague. Paz reported her family and life story in the framework of the thematic field: "Zionism and the kibbutz." She introduces herself as a "Sabra," child of a country her parents built up in defiance of the German madness aimed at destroying everything Jewish. Paz condemns her brothers for choosing to live outside the kibbutz. She accuses her brother in America of treason against Zionism. Secretly, she attributes this desertion to her parents' failure to bring him up properly. On the other hand, she emphasizes that most members of her generation have stayed on the kibbutz and remained true Zionists. In the course of these declarations, she repeatedly compares herself with the pioneer generation of her parents, using phrases like *"I am nothing compared to the first generation."* Paz identifies herself strongly with her parents' original aim of building up a stable Israel; but she also clearly accuses them of treason against the old ideals. Paz cannot understand what made her parents reestablish contact with Germany and with Germans, referring, in particular, to her father's earlier opposition to having young Germans as "volunteer workers" on the kibbutz.

Paz is in very strong conflict with her mother. Though they live on the same kibbutz, Paz has hardly spoken to her for a number of years. She maintains that the bad relationship is the result of her mother's inability to show her feelings, and because her mother had given Paz's brothers preferential treatment. The way she sees it, this has something to do with her mother's



German upbringing. Between the lines, she lets us know that her parents were not the only ones who suffered because of Germany; she, too, had to suffer due to her mother's German upbringing. Like other women of her generational unit, Paz is incapable of putting herself in her mother's position. Because of this, she cannot understand that her mother's emotional difficulties might be an effect of the persecution and loss that she suffered. Paz does not see either her father or her mother as people who have been persecuted. A critical aspect in this context is that for a long time her parents split off their grief at the loss of their families and suppressed their memories prior to the emigration. This makes it more difficult for their children to empathize with their parents.

The interview text clarifies the manner in which Paz interrelates the themes 'Zionism', 'the relationship to her parents', and 'the relationship to Germany'. Paz starts telling her main narration in a manner typical for her generation unit: she does not present it as an integral part of the family history. When asked to narrate her family story and her own life story, she replies: "*I'll start with my own life story; that's easier. Well, I was born on kibbutz Z.*"<sup>98</sup>. The account of her childhood that follows this 'editor's aside' belongs in the thematic field "Israel's refugees found a kibbutz." For instance, after a few short remarks concerning where her family lived before moving onto the new kibbutz, she states:

*"...we moved to K. ... I was among the first children who arrived here and later the entire group of children joined us. We went through all the phases of building up my kibbutz. I grew up with the first children (of the kibbutz) and we had a very interesting childhood, compared with what you see nowadays. This is because we experienced the entire war as well as the liberation and all that was related to it: bunkers at night and all the other things that a child experiences during a war."*

While talking about her life on the kibbutz, she emphasized again and again the Zionist conception of Jewish history: "Constant emigration and suffering will end, once we arrive in the land of milk and honey." For Paz, the Promised Land is closely linked to the kibbutz. As in the preceding quotation, Paz shifts in her account between the articles "I" and "we" and tells much more about the collective history of the kibbutz than about her own life history. The analysis of this interview makes it clear that behind her identification with the kibbutz, and in particular with her age group, she hides a desire for a closer relationship with her parents. Concentrating on the history of the collective helps her to distance herself from the family history, which is highly problematic for her. She does not talk of the difficult relationship with her parents but prefers to present them as heroic pioneers who had clear ideals. When talking

---

98 These quotations have been translated from the Hebrew.

about her life as an adult woman, her main theme is her professional activities, which she describes as Zionist education work for the benefit of the collective.

In the self-structured part of the interview, Paz does not talk about her family history. When asked about it by the interviewer, she has little to say about it. Though she knows about the murder of her grandparents and of her parent's siblings, she shows no emotional reaction. She mentions only fragments relating to her mother's family, then changes the subject to her father's where she is on somewhat firmer ground. She tries to make the history of her grandparents fit into one of collective heroism: she speaks of the uprising in the Warsaw ghetto, of the concentration camp history, the letters which reached her parents from the concentration camp, and mentions the death of her parental grandparents in Auschwitz. While on this subject, Paz shifts to amplify on the relationship to the Germans after the Shoah. She argues that her hatred of Germans is somehow related to the fact that her father has forgiven the young Germans. We interpret this sequential order of the two themes as indicative of the following: Paz' hatred is related to the murder of her grandparents, but on the manifest level, she connects it to the behaviour of her father and young Germans. Thus, she transfers her feelings to present phenomena. This probably helps her to avoid being crushed by feelings of sorrow and rage about the murder of her grandparents. Related to this is the fact that Paz refuses to see things from her parents' perspective of that time. When asked by the interviewer if she ever tried to imagine what her father felt when he received his parents' last letter, she replies:

*"I cannot try to imagine that because the truth is that I have never talked with him about it. I don't know if he knew what happened to the Jews in 1944. I don't know how much information reached the Jews in Israel and others who did not live through it themselves. Had he had that information, I believe it would have been very hard for him. But I just cannot tell you. I don't know if he had that information".*

Asked by the interviewer if she remembers an occasion when she talked to her parents about the Shoah, she replies in the negative: *"I heard almost nothing from my parents for the simple reason that they did not experience it themselves."*

Paz has obtained information about that time from Shoah survivors rather than from her parents. In her argumentation, Paz considers only those, who suffered persecution themselves as being survivors of the genocide, and thus detaches her family history from the Holocaust. She does establish, however, a connection to the Shoah on an emotional level when she argues and becomes indignant over the Germans and her parents' connection to Germany. Most informative were the dynamics that took shape during the family interview to which we had invited Paz Israeli and both parents. This time, Paz

agreed to have a German interviewer present, too. The conversation was conducted by Bettina Völter, a German, and Tamar Zilberman, an Israeli, in English, German, and Hebrew. Aharon Arad does not speak English well enough to express and understand everything; his contributions in German, therefore, were translated into English for the benefit of Paz Israeli and Tamar Zilberman, and the English contributions were translated into German for Aharon's benefit. Toward the end of the conversation, it became obvious that Paz understood her father's German very well. When she revealed this, her parents let it be understood, that they did not believe her, and continued to avoid communicating directly with her in German. Even though the presence of the Israeli interviewer would have made a direct Hebrew dialogue between parents and daughter possible - an arrangement repeatedly offered by the interviewers -, Aharon addressed his daughter directly in Hebrew only at rare occasions. This complicated interaction already provides reference points concerning the communication structure in the family. As a result of this laborious translation arrangement, all verbal contributions had to be channelled by way of the German interviewer, that is, had to be translated and transmitted by an additional person. Thus, it was difficult for the family members to establish direct contact with each other. They rarely listened carefully to each other and had the greatest difficulty in responding to each other's contributions. The translation and the German interviewer served as intermediary for communication about the family history. But the ambivalence toward the German interviewer was ever-present. Paz arrived at the appointment half an hour late. Her father had established good contact with the interviewers, when he had talked to them alone, but now appeared very nervous and unwilling. He emphasized that he wanted to keep the conversation as short as possible. Paz, too, had announced over the phone that she could spare only half an hour. But during the conversation, she opened up more and more. This time, it was Aharon who took on the role of the one who rejected the German interviewer. In response to the general question about what had happened in the meantime, he initiated the conversation with the theme of "aging and sickness." He mentioned that having undergone coronary surgery, he had become more emotional. He called attention to a phrase that he had already used in the first interview. He thought of it often during the last year, as it shows his true feelings: *"I hate myself because I can not hate the Germans."*

Having said this, he brings up the "German" theme at the very start of the conversation. Dorit, too, talks about her ambivalent relationship to Germany, and Paz argues that even though she learned nothing about the Shoah from her parents, she has emotionally greatly distanced herself from Germany. But since her parents also maintain an emotional distance to Germany, Paz, surprisingly, can state that she wishes her children had learned more about German culture; but her parents' negation of their German past would have made this impossible. Paz primarily accuses her mother of letting her know too lit-

tle of the family history and reports that in the meantime she has read her father's biographical notes. In reply, Dorit argues that she could not put her story down on paper, the way her husband had. When we offered Dorit's life story tape to Paz, Dorit refused with the words: "*I want to keep the story for myself.*"

We may assume that Dorit's guilt feelings concerning her own family are based on specific personal experiences which she does not want to share with anyone. But keeping in mind her statement that to have served in the British army and waited before having children would have been better instead, another interpretation might be the correct one. It could also be that Dorit connects her guilt feelings with the birth of her daughter, and that she avoids talking about everything which is related to that time, so that she may protect her daughter from her ambivalent feelings. In the conversation, this clearly provokes non-acceptance from her husband and daughter; they talk and laugh in conversation among themselves while Dorit speaks. This robs Dorit of an opportunity in which she might have succeeded in sharing her painful experiences and guilt feelings with them.

In the course of the conversation, Aharon's wish to travel to Germany in the company of his daughter becomes apparent. Paz reacts negatively to this offer of approaching the family past. She talks at length of her psychological problems and fears related to Germany. Finally, she declares that she would travel to Germany if her father asked her to. Aharon, too, is ambivalent in his request. This is indicated by the fact that he does not address it directly to his daughter, but tells the interviewer about it instead. He answers the interviewer's question about whether he could imagine directly asking his daughter to travel with him to Germany, with: "*yes, but not on my knees.*" To that she responds: "*please, don't beg me.*" The significance of the dynamic between Paz and her parents for Paz's children is illustrated by the case of Paz's oldest daughter Galit.

Galit Israeli, interviewed by Tamar Zilberman, was born in 1967, the year of the Six-Day War, which in Israel gave rise to an atmosphere of self-confidence and belief in the country's strength. At that time, life on a kibbutz was no longer considered the best and only way of achieving a Zionist society. Zionist ideas were being increasingly scrutinized. As Galit grew up in this climate, we may ask what way she chose to continue the family traditions. In 1982, at the age of fifteen, Galit lived on a kibbutz located on the Lebanese border. There she experienced the Lebanese bombardment of the kibbutz, as her parents and grandparents had. Once, a bomb exploded near her home. This military situation, known as "Galilee Peace," provoked contradictory reactions in Israel<sup>99</sup>; but for those who lived in Galilee, in the North of Israel,

---

99 At the beginning, the population still accepted the military objective, which was declared to be the destruction of the PLO infrastructure in Lebanon. But the Israeli population found it incomprehensible that their army would advance into Beirut and not intervene, when Le-

it meant, first of all, securing a constantly threatened frontier. Before she was drafted into the army, Galit moved into a large town, where she volunteered for a year as group leader of a socialist youth group. In the military, she held a position that was highly desirable for girls. She served as a non-combatant soldier on a parachute infantry base. There she met Jaacov, like her father a man of oriental family background, whom she later married. After their military service, both lived for a year on Galit's kibbutz. Then the couple stayed for a year with her mother's brother, Galit's uncle, in the United States. On their return, they married and soon left the kibbutz. They now live in Tel Aviv where Galit has started her studies at the university. They had their first child in 1993.

Galit resembles her mother to a surprising extent. It is remarkable that she, also, accuses her mother of not having been a good mother. Like her mother, she tries to prove to the interviewer that she, however, is a very good mother. She, likewise, has the feeling of being more on her father's than on her mother's side, particularly after her parents divorced. Like Paz, Galit married very young. She, too, met her husband, a man of oriental family background, during her military service. But in contrast to her mother and her mother's expectations, she left the kibbutz. In Galit's life story, Zionism and kibbutz no longer have as important a role as in that of Paz, her mother, who constructs her life story out of the family history on the basis of these two concepts. The reconstruction of Galit's case demonstrates that "death" is one of her central themes, and that she connects this with the family history.

We notice that Galit starts the interview in a manner very much like that of her mother. She does not talk of the family history that precedes her, and begins with her own biography: *"I was born in 1967 on kibbutz Z., the first child and grandchild"*. She then relates her life story within the thematic field: *"My life on the kibbutz"*. This ends with the narration of how she became a mother. Her justification for having left the kibbutz is that she felt like she was suffocating there. She talks briefly about her studies. Speaking about the years after she left the kibbutz, she concentrates on presenting herself as a good Israeli who did not leave the country. Obviously, she feels a need to justify the fact that she no longer lives on a kibbutz. The theme "emigration from Israel" is present at the same time. Galit concludes the evaluation of her life by saying: *"It's a life between being a kibbutznik and an Israeli."* After this conclusion, she talks again of her childhood, without being asked to. This time her stories are related to the themes: "fear, danger, and death". Galit narrates about people in her life who have died, like four of the young people who grew up with her on the kibbutz. Instead of talking about friends of hers who are alive, she mentions only those who are dead. The granddaughter also

---

banese Christians committed massacres in Palestine refugee camps. This, so to speak, ended Begin's military 'leadership'. (cf. Guggenheim 1987, p.387)

dwells on the danger to her own life to which she had been exposed during the Lebanon and Gulf Wars. On the surface, these themes are not related to the Shoah. Like her mother, Galit does not take the initiative in talking about the family history, though in the initial question, she had been asked to do so. In other words, she narrates her autobiography in chronological order without talking about the family history theme as requested. Instead, she once more relates her life story within a new thematic field or context. While initially she had incorporated her life story into the collective history of her kibbutz generation, in the second part of the interview, she dwells on personal fear, danger and death experiences. Galit knows very little about the history of her grandparents and about that of her parents. The lack of dialogue between her mother and her grandparents recurs again in the third generation. Galit reports that her grandfather "gave up" talking about his past and, instead, has written a book. Asked by the interviewer if she knew what had happened to her great-grandparents, she replies "they died in a camp," but she does not know in which. And when asked if she ever had fantasies about their death, she replies that she has to remind herself from time to time that close relatives died in the Shoah, because she feels so little connection to this.

Galit and Paz are both blocked from dealing with the fate of the dead in their own family. Galit reports that her grandparents sometimes tell her stories about the family, but she always forgets them. We assume that Paz, her mother, shows little empathy towards her parents' past. Their guilt feelings and ambivalence, however, make a dialogue about the past more difficult. The grandfather, Aharon, tries to pass his story on by writing a book. In this family, direct communication about the family history seems fairly blocked.

In the family interview that Gabriele Rosenthal and Bettina Völter conducted with the Arad grandparents and their granddaughter Galit, the same structure of blocked communication is found. Similarly to what happened in the family conversation with her mother, interaction between the participating family members, this time too, is only possible through the interviewer. The dialogue does not function properly, though they have been asked explicitly to address each other in Hebrew. Furthermore, the granddaughter Galit says from the beginning that she can only spare half an hour of her time. She says goodbye the very moment her grandfather starts talking about his fantasies about the death of his parents. She probably feels excluded from the conversation because he speaks in German and hardly leaves time for translation. On the other hand, the interviewer brought up this sequence when she asked Aharon what he considered most important in the family history and wished not to be forgotten. This question and the first part of his reply, which deals with his ambivalence towards Germany, are translated for the benefit of the granddaughter. But she does not wait for the second part of Aharon's reply and leaves the room exactly at the moment when he is talking very emotionally about the significance of the Shoah for him and his family.

We can assume that the thematic fields "relationship to Germany" and "the Shoah" usually cause problems in the Arad family's intergenerational dialogue. This is also indicated by the interview with Josef Arad, the third oldest of Aharon and Dorit Arad.

Josef Arad, the third child of Dorit and Aharon Arad, was born in 1950. While the birth of his sister Paz is chronologically and emotionally related to the persecution and murder of his grandparents, the birth of Josef is connected more closely with the 1948/49 War of Independence. The biographies of the men of this generation are more closely tied to Israel's wars than those of the females.

Like his sister, Josef complains that his parents did not pay enough attention to him when he was a child. Like the other children of his birth cohort, he grew up in the children's house of his kibbutz. In his opinion, the lack of attention on the part of his parents made him rebel in his youth, and caused him to have serious problems in school. He was expelled before he could pass his university entrance examinations. Josef began an apprenticeship and then, shortly after the Six Day War, was drafted to do his military service on the Syrian frontier. "*We chased terrorists*", he states in an ironical and detached way. Generally, he views his military service in a critical light. After his army service, Josef Arad returned to the kibbutz. Two years later the Yom Kippur war of 1973 started and Josef was drafted again. Many of his friends were killed in this war. Josef Arad was also in mortal danger several times. He experienced the Lebanon War of 1982-1984 as a soldier at the front line as well, and during the Intifada (starting in 1987), he repeatedly saw action in the occupied territories while doing his obligatory annual reserve stint. In the middle of the 1970s, Josef began to travel to different countries in Europe. The dates coincide with those of his parents' first trips to Germany. The interview with him shows that Josef tries, more than his sister, to comprehend what caused his parents to change their attitude towards Germany. He, too, visited Germany several times and explains that he has friends there. In the meantime, he has lived for a while with a Swedish girlfriend in her country. We can interpret this as an attempt to try living outside of Israel. In this context, he relates several incidents in which he felt offended as an Israeli and a Jew. One of these was an encounter with a German who held it against him that Israelis allegedly put Arabs in concentration camps. In this situation, Josef reacted defensively, even though he felt very aggressive towards the German. A remark he makes to convey the significance of the story shows his general vulnerability when abroad: "*Every time I leave the country, they beat up on me one way or an other.*" This story indicates the difficulties of the biographer in expressing his aggression as well as his feelings of vulnerability towards Germans. Upon his return from Europe, Josef left the kibbutz and started to work in Tel Aviv with handicapped children of oriental background. There he met his future wife. She grew up on a kibbutz that was set

up been developed in the 1920s and early 1930s by Zionist immigrants from Eastern Europe, including her parents. Thus Josef, like his siblings, married into a family whose members had not experienced the Holocaust first hand. This is one mechanism that makes it possible for him to keep away from the ambience of his parents' German background.

Josef's first daughter was born in 1980. He started to study design, found work as a graphic designer for weekly publications and, among others jobs, worked with some authors who write about the Shoah. He did photo research for their reports and was responsible for the layout. In his spare time, he wrote.

How, then, does the presentation of Josef's family and life history take shape in the interview? Unlike his sister, he allowed himself in 1995 to be interviewed in English by a German as well as by an Israeli. Bettina Völter and Hagit Lifschitz conducted the interviews. During the conversations, he spoke almost exclusively to the German interviewer and only turned to her Israeli colleague to interject something in Hebrew; most of the time to ask *"why am I telling this to a German?"* At the most emotional point in the interview, Josef began to cry and, turning to the Israeli interviewer, asked in Hebrew *"why am I crying in front of a German?"*. The atmosphere of the entire conversation is defined by the strong ambivalence between his inclination to come into contact with a young German and the aggressiveness this contact brings up in him. This ambivalence also finds expression in the fact that, later, Josef Arad lets his parents know that he was very pleased with the interview because he had only rarely been able to talk that openly about his life.

Even before the interviewer has asked the initial question about his family's and his own life history, Josef tries to clarify something for himself. He had heard from his parents that the interviewers were doing research on "the second Holocaust generation". He says that his family does not belong to this group: *"My parents did not experience the Holocaust; I mean to say they only lost their parents (he breathes heavily)"*. Like Paz, Josef at first distances himself from the persecution in his family's history. But unlike her, he starts the conversation by choosing the murder of his family members as his theme. By using the formulation that his parents had "only lost their family", he avoids, just as his sister did, accepting the perspective of his parents and expressing his connection to these family members. In what follows, the biographer speaks mostly of "his parents' parents" and not of his grandparents or his family. Josef also differs from his sister in that he responds to the initial question by relating the family history of his parents prior to their emigration to Palestine. One could call the thematic field of his main narration "A life in Germany that has been lost forever". In trying to reconstruct his parents' life in Germany, the narrator finds that he has difficulties in retaining the story and making it his own:



*"It is a very hazy picture that I have of the home in which each of my parents grew up; I can hardly imagine how it was... I put it all on a video tape. Sometimes I can watch this and listen to their stories (laughs) I mean to say, I will still have it when they are dead."*

Josef Arad's main difficulty is understanding the family history as part of his own history; it is a task to which he feels inexplicably drawn. Some years ago, he questioned his parents about their history and preserved the interview on video tape. It becomes clear that Josef assumes the role of the one who preserves the family history. But some of the difficulties he faces in identifying with that history also become obvious. In his presentation, he concentrates on the comfortable bourgeois status of his grandparents. His evaluation is: *"It was difficult for us, who grew up in an almost communist society, to listen to this, to be proud of it"*.

His parents repeatedly mention, how completely integrated their families were into German society and how they had had nothing to do with "Eastern European" Jews. This represents a special problem for Josef: *"We always had the feeling (I) we are part of the whole. We were not just Eastern European Jews who had come to Berlin to find something to eat; we were not Eastern Jews."*

Furthermore, he is preoccupied with the close alliance between his father's family and non-Jewish high society, a matter of great pride to his father till this day. In his own mind, he makes the association that these were friendships with those who later became National Socialists. This coincides with his mother's characterization of her parents. However, he is primarily critical of his father; his father's ambivalence toward Germany causes Josef extraordinary problems. While his mother manages to avoid this ambivalence, his father to this day *"is practically magnetized by Germany"*:

*"She never spoke about her feelings concerning Germany; somehow she separated, I mean to say, she wanted to become an Israeli and she succeeded. My father is more of what we call a 'Galutee', he is an exile Jew, a person who arrived with a different mentality, not an Israeli, it's like he's in exile"*.

Josef reports that when he was a child, he felt his father had typically German qualities, such as his blind obedience to authority, and that this was treason against Israel. We may assume that he also felt personally hurt because he sensed that his father felt drawn back to Germany and thus did not pay him undivided attention. As he states, he would also have preferred to have had a father who was a fighter. In the eyes of Josef, his father's ties to Germany made it impossible for his father to become a genuine Israeli.

During the self-structured part of the interview, Josef talks about the dates of the persecution and murder of his grandparents. He does not know where his mother's parents were deported to at the start of the war. But he

does know, that his paternal grandparents arrived in Theresienstadt in 1943, and speculates *"like all Jews who belonged to the elite"*. As he sees it: *"I don't know much about it; I mean to say these are people I don't know."* He does not know anything about the fate of his father's sister and only that his mother's brother supposedly died of post-operational complications before the persecution started. Thus, he has no knowledge of those parts of the family history which for his parents are the most problematic ones. We may assume that the guilt feelings, which Aharon and Dorit have, concerning their siblings in particular, have blocked the transmission of this part of the family history. The constant switching in the text structure - from "what I know" to "what I don't know" - provides insight into the difficulties encountered by this member of the second generation in the reconstruction of his family history and his painstaking efforts to arrive at a coherent story.

The analysis of the way, in which Josef presents his own life story, elucidates how he is tied to the family past, and how in the course of his own life he tries to come to grips with his feelings of guilt which are related to that past. Josef, like his sister, relates his life story primarily within the framework of the collective biography of his generation. The themes "life on the kibbutz" and "soldier in several wars" are the main themes in his life story. Josef Arad describes himself as an Israeli whose task and purpose is to defend his country. He differs from his sister, who considers herself primarily a kibbutznik, in emphasizing his role in defending the country in time of war. Having left the kibbutz as a young adult, this is the part of the Zionist delegation which he fulfils, though he also has his doubts about it. He is tortured by strong guilt feelings that put his actions during his military service in the context of the Shoah. He asks himself whether he acted like a Gestapo agent during the Intifada.

The fears hidden behind his doubts become obvious if we bear in mind a play that Josef has written when interpreting his interview. His mother translated the play, which takes place in Germany, and gave it to us to read. Thus she, also, indirectly conveys a message to us. In the play, a young man, who claims to be a neo-Nazi, goes on trial for killing an old man. During the course of the trial, it turns out that the victim was an old Nazi, while the young man accused of murder is the son of a survivor. It is revealed that revenge against the old man was the young man's motive for killing him. Before 1933, his mother had had an affair with the murder victim. After the Nazis came to power, her lover had become a fanatic party member and delivered the supposed neo-Nazi's mother into the hands of the Gestapo, and was thus partially responsible for her being sent to a concentration camp. What does this play tell us about the motives of the author? We could interpret it as Josef's parable about his own feelings and the way he views his family history. We associate the figure of the mother of the supposed neo-Nazi with Josef's grandparents and their view of Germany which resulted in their mur-

der. The character of the supposed neo-Nazi probably reflects Josef's fantasy of being a later generation avenger of the perpetrator's crimes. We may ask ourselves if Josef also fears that his feelings of aggression might overwhelm him. Moreover, we may assume that the play also expresses feelings that his mother has suppressed and which she does not allow herself to communicate to us directly. But Josef has found a way to work through his feelings of aggression and guilt in connection with the history of his family in his biography. Not only his work as an author but also his commitment to oriental Jews helps him to do this. He argues at length in the interview, explaining how difficult it is for those who emigrate to become integrated into Israeli life. Against this background, he does not presume to judge his parents' behaviour, even though he wishes that in some respects they had acted differently:

*"They spent the best part of their youth here in Israel. When all of Europe was burning, when their parents were already incarcerated, they sang and danced and ate whatever was available to them in those days, in the 1940s.... I do not know how often they thought about it, I never asked them, how often, how much, what they felt at that time. But I know one thing, because I was young myself. When you are young and full of hormones, when the sun, this Mediterranean sun shines, when the sea is blue, then you don't care all the time about what happens, let's say in Somalia. You sip your coffee and have a good time".*

Josef was born in 1950, a few years after the end of World War II and of the Shoah. It is easier for him than for his sister, whose birth coincides with the murder of her family members in Europe, to take on his parents' perspective. Here we must take into consideration the highly disturbed relationship between Paz and her mother. To be able to keep a distance from her mother, Paz must actually protect herself from taking her mother's perspective, or reflecting on the consequences of the persecution in her parents' past. But even Josef finds it difficult to see his parents in the context of the persecution in their past. In his case, as in that of his sister, we can conceive of this also as an interactive product created by parents and children. As we have tried to demonstrate, this also has an impact on the third generation.

### Concluding remarks

The interviews with the grandparents of this family, who were forced to emigrate in their youth, indicate the difficulties in the mourning process related to their murdered family members. In their biographies, members of this generation try to resolve their traumatization by rejecting their German past and by strongly identifying themselves with Israel and the Zionist delegation. The case of this family also demonstrates that the children of the Youth Aliyah generation have likewise chosen the development of Israel, its preservation,

and its defence as their strategy for overcoming the past, preventing its recurrence, and fighting to live. But along with their parents' ambivalence and blocked mourning process, we encounter problems in the intergenerational dialogue. The example of the grandchildren of this family of the "Youth Aliyah Generation" clearly shows that the blocked dialogue between parents and grandparents even renders it difficult for the grandchildren to gain access to, and empathize with, the life stories of their parents and grandparents. The blocked mourning process, their denial of their longings for Germany account for the aggression towards Germany and guilt feelings which play such an essential role in the family dialogue as well as in the individual biographies.

## 12. The intergenerational process of mourning: The families of Fred, Lea, and Nadja Weber

*"Three siblings who survived under different circumstances"*

Gabriele Rosenthal, Bettina Völter and Noga Gilad

In the following pages, we present the story of a family whose first generation consisted of a brother and two sisters: Fred (born in 1922), Lea (born in 1923), and Nadja Weber (born in 1930). Thanks to the Children and Youth Aliyah, they were all able to leave Germany. Today they live in Israel with their families. Their life histories and the dynamics of their family are different from that of the Arads. Thus, they serve as a contrastive comparison to our earlier considerations. One critical difference between them and the Arad grandparents is the fact that the three Weber siblings did not live in Palestine during World War II. Thanks to the Youth Aliyah, Fred, the oldest brother, came to Palestine in 1938, but left the country in 1940 to fight against Nazi Germany as a soldier in the British Army. His two sisters, Lea and Nadja, managed to leave Germany and come to England thanks to what was known as the 'Children's Transport,' a British law enacted in 1938 that granted asylum to 10,000 (Jewish) children from Germany. The youngest of the children were six, the oldest fifteen years of age (cf. Wetzel 1938, p. 483).

The parents of Fred, Lea, and Nadja remained in Germany, though they - unlike the Arad parents - had spared no effort in trying to emigrate at an early stage of the Nazi regime. In the Arad family, the great-grandparents are reproached - though in a latent manner - for having felt too great an attachment to Germany, thus having failed to recognize the portents of the time early enough. In the Weber family, the dialogue is more strongly determined by criticism of the Zionist organization that failed to make it possible for the parents to emigrate. While the problematic ties to Germany represent the central theme in the Arad family dialogue, the theme that concerns the Weber siblings is the question of why they, but not their parents, were able to leave Germany. As a result, they quite openly admit their ties to Germany and to non-Jewish Germans. This is most obvious in the case of Lea, who is virtually obsessed with memories of her parents and her life in Germany prior to emigration.

Lea, like her brother, belongs to the generational unit which emigrated from Germany in mid-adolescence. In contrast, her sister Nadja was only nine

years old when she left. She was separated from her parents during a phase of development in her life, in which separation can be much more of a factor in causing insecurity than in mid-adolescence. Neither for Nadja nor for Lea did England become a new homeland. We shall show through the case of Lea, her children, and grandchildren, how these biographical constellations have caused her family to differ from what we have considered the ideal type of family established by those who had been forced to emigrate in their youth.

Let us first consider the family history of the siblings: Fred, Lea, and Nadja. Even before the Nazis came to power, the Webers were active members of a Zionist organization. The mother had been a Zionist since the beginning of the 1920s; it was she, primarily, who, starting in 1933, tried to get the entire family to emigrate to Palestine. In 1932, at the age of ten, her son Fred became a member of a Zionist youth organization; his sister Lea one year later. This is a significant difference between this family and the Arad family. By living in Israel, Fred, Lea, and Nadja carried out a delegation their mother had given them, while the parents of Aharon and Dorit had mixed feelings about the emigration of their children, who left with the intention of returning to Germany after the end of the war.

Fred Weber left his parents' home and his birthplace in the eastern part of Germany when he was 15 years old. In the spring of 1937, because he was Jewish, he was forced to leave the high school he had been attending; he went to a Zionist agricultural school in Berlin to prepare himself for Palestine. Only one year later, he stepped off a boat in Haifa as one of a Youth Aliyah group and became a member of a kibbutz in the south of the country. When in September 1940 the Italian airforce bombed Tel Aviv, he enlisted as a volunteer in the British Army.

Shortly before Fred left Germany, the family moved to Berlin after the father had had to close his small retail business. There the mother attempted to obtain an exit certificate to Palestine or find other means of emigrating. The maternal grandmother was the first to leave Germany; in 1937, she was able to go to Portugal with the family of her son. The Weber parents did not have the money to obtain a "capitalist's certificate" (the British administration in Palestine issued special immigration visas to German Jews in possession of a substantial amount of capital). The mother then searched desperately to find a way for her daughters to leave the country. After many failures, she succeeded in getting them safely to England which they reached as members of the "Children's Transports." Nadja, who had just turned nine, was taken in by foster parents in London. Her sister Lea found work as a domestic servant for a family in the north of England. Despite their strenuous efforts, the parents did not manage to get out of Germany. They sent letters to the children and their family in Portugal asking them for help with increasing urgency, they also begged for money so that they might buy capitalist's certificates. In 1942, they were deported to the Theresienstadt (Terezin) concentration camp.

The father died there in 1943; the mother informed their children of his death by a letter to the family in Portugal, a way of communicating still possible at that time. In May of 1944, the mother mailed her last post card to the family in Portugal, telling them that she would soon have a new address. Until liberation, the siblings were convinced that she was still alive. They absolutely refused to think it possible that their mother might have been murdered. This is indicated, among other things, in a letter in English that Fred wrote in May of 1945 to his sister Lea in England. He first described the beauty of Paris in enthusiastic terms; then he inquired about their mother: *"Did you hear anything of mummy? I couldn't find her name on all the lists here. Well, I am closing now to go to the cabaret."*

Not until 1946 did Lea learn through the Red Cross that her mother had been sent to Auschwitz. By that time, she herself was the mother of a little girl and lived in Palestine: *"That was the first time that I heard the word Auschwitz"*.

To this day, the murder of their parents is a central element of the family dynamics. An unspoken question is always in the air: "Why could we not save our parents?" Without talking about this, they reproach themselves and each other for their failure. Because of the resulting considerable tension and the accusations on all sides about having helped each other too little, they make great efforts to keep alive the memory of their parents and to comply with their parents' wish that harmony should prevail among the siblings. They remain in close contact and celebrate the holidays together. Fred helps to make them form a truly integrated group, his presence lessens the tension between the sisters since he is, psychologically, the most stable of the siblings.

While the Arad family members talk openly about their feelings of aggression against Germany and Germans, we encounter, in the case of Fred, Lea, and Nadja Weber, an obvious need to maintain contact to Germany and to avert feelings of aggression against that country. For the three of them, aggression and hatred are feelings, which are prohibited rather than permitted and, above all, must not be shown in the presence of the other siblings. Again and again they stress that they have not passed on to their children any feelings of hatred towards Germany. The following dialogue developed in a family interview<sup>100</sup> with Fred and Lea:

- Fred:            There is no right to hate.  
Lea:            That's what we share, the lack of being able to hate.  
Fred:            That was part of our education at home, even the word hate was taboo.  
Lea:            In our family there was never, never hate, never, never, not even between the lines. That is what saved us.

---

100 This family interview was conducted in English by Yael Moore and Bettina Völter.

- Interviewer: If you did not feel hatred, what did you feel when you had to leave Germany?
- Lea: I was very unhappy ... and I complained to my brother; he was the only one who could save me.
- Fred: There was no time to complain, because in the war I joined the army ((addresses Lea at the same time))
- Lea: But before the war, when I came to England I always said my big brother will save me.
- Fred: The big brother was seventeen; he had not much time to save, he could do nothing
- Lea: It was like with my parents. I could do nothing.

Condensed within this short sequence we can find the whole tragedy of this family. The central theme in the family dialogue is not rejection or even hatred of Germany but mutual accusation and justification. However, as we shall show in the following pages, this has a different meaning for each of the three siblings.

We start with some observations concerning Fred's role within the family. Lea and Nadja, as well as the children and grandchildren of all three siblings, present Fred as the hero and fighter in the family. He is seen in the perspective of the family myth of heroic fight against the Nazis. This fits within an identical collective Israeli myth. Related to this myth are their attempts to reject and even resolve the past experience of helplessness and defencelessness. Fred, too, was unable to save their parents. If we observe his life history during World War II, it nevertheless becomes obvious that this theme is quite threatening to him. When he was in Israel, Fred<sup>101</sup> received letters from his parents time and again in which they desperately asked him for help. He has carefully preserved these numerous letters and shows great emotion when he lets the interviewer see them. Whenever he mentions the letters in the interview, he next turns to the subject of 'my voluntary enlistment in the British Army'. This indirectly reveals that by enlisting at that time he tried to overcome his feelings of helplessness and guilt. The above quotation also makes it obvious that he rarely was able to write letters after he had entered the army in 1940 and, subsequently, had become a prisoner of war. He states this in response to his sister's reproach that he did not write - a reproach in which she also gives vent to her despair at the time. Moreover, he was engaged in a fight for survival. He justifies his engagement by saying: *"It was our Jewish-ah, our duty to fight. It was the only way to help stop this evil. That is the reason why I joined, why I fought"*.

He speaks of "Jewish duty" and thus gets across to us something of the collective spirit during that period in Palestine. At that time, the mass media depicted joining the British Army as serving the nation, and compared it to

---

101 In 1994, Fred was interviewed twice by Tamar Zilbermann.



becoming a member of the “Haganah” or “Palmach”. Tom Segev (1995, p. 117) mentions the many appeals to volunteer for military service which in those days appeared in the daily papers. By the end of the war, 30.000 soldiers had enlisted<sup>102</sup>.

Fred Weber fought first in North Africa. Captured in Greece in 1941, he was sent to a prisoner-of-war camp. More than 1.500 of the Palestinian Jews, who had volunteered to serve in the British Army, were captured and sent to POW or forced labour camps in Germany. But unlike Jewish members of the Soviet and Polish Army, Jewish soldiers of the British Army were treated the same as other British soldiers (cf. Jaeckel et al. 1995, p. 816). Fearing retaliatory action against his parents, Fred decided to hide his German origin and declared himself to be a native of Palestine. He says he thought this would make it easier for him to escape. He tried to escape several times but was always recaptured. At one of these attempts, two other soldiers who had fled with him were arrested and executed.

In the spring of 1944, Fred succeeded in escaping. He managed to reach Berlin and to establish contact with a resistance group. After only a few weeks, furnished with falsified documents that would allow him to go to Sweden, he was captured again. On this occasion, he had the presence of mind to chew up and swallow his documents. He pretended to be a native Palestinian serving in the British Army and not to be able to speak German. After he was cruelly interrogated and tortured in the Gestapo prison many times, his story was given credence. Together with more than 100 other prisoners of war, he was sent to the 'small fortress' of Theresienstadt. Prisoners of war and political prisoners were confined to this fortress, which was located outside the concentration camp established in Theresienstadt. Fred found himself very close to the camp where his parents had been sent. He knew that his parents had been detained there and that his father had died there, because in the meantime he had received occasional letters, and even packages, which Lea had sent through the Red Cross. But Fred could not at that time know whether his mother was still in Theresienstadt or not.

What might have been Fred's thoughts and feelings about his surroundings while he was in Theresienstadt? Did he try to search for his mother or did he find it too dangerous for him, a man who had taken on another identity, to make inquiries about a mother who had come from Germany? We found out nothing about this, neither in the talks with him nor in those with his son and grandchildren. Fred hardly wants to talk about this phase in his life. In interviews with him alone, he talks at length about the time before Theresienstadt but tries to avoid the topic of his time in Theresienstadt. He makes this explicit by stating that *"there is no need to tell you about the concentration*

---

102 The Jewish brigade, a unit of 5.000 men with its own flag, was activated, however, only during the last months of the war during which it saw action in Northern Italy.

camp". When the interviewer asks him to say more about it, Fred sticks to a description of his cell, shows pictures of executions, but relates no personal experiences. On the other hand, he talks of his renewed flight from Theresienstadt together with another prisoner. Both succeeded in escaping, and Fred joined the American Army and then fought in its ranks. Fred now talks of the hatred and the feelings of revenge the Americans had towards the Germans. He states pithily: *"We stopped taking prisoners"*. Regarding the murder of the German prisoners of war, he says: *"We became as inhuman as the Germans themselves"*. It becomes evident how hard this survivor tries to retain his moral integrity and how severely he judges himself. In a joint interview with his sister Lea, he speaks of an experience in his life when he could have killed some Nazi minion. But he stresses: *"because of his deeds, but it was never that I could kill him because I hate him, not because he is a member of a group."* Asked what cruelties he had experienced personally from the hands of Nazi persecutors, he mentions the public executions in Theresienstadt. He witnessed an inmate being beaten to death and another being hung by his feet. However, in this family interview, it becomes obvious that he does not want to talk much about these and other persecution experiences, for example of his being tortured in the Gestapo prison. Fred rather relates those occurrences in his life history that show him as an activist and fighter, not as one who suffers passively. Unlike his two sisters, in particular unlike Lea who stresses her suffering more than anything else, he pointedly minimizes this aspect. On the one hand, we interpret this as the consequence of his experiences which differed from that of his sisters: It was possible for him to fight; whenever he was able to take the initiative, he also had a chance to give expression to his rage against the perpetrators. These important experiences in his past endow him with psychological stability. On the other hand, Fred represses his own sufferings. The reason might be his feelings of guilt toward his parents whom he was unable to help. From his perspective, a comparison of his life history with the history of his parents' sufferings does not give him the right to complain. Dialogues with his sister Lea also make it obvious that Fred, unlike his sister, has a need to consider himself a survivor of the Shoah. He declares *"I am a survivor"*, to which Lea replies *"Who am I? I wasn't in a camp and my mother did not even survive"*. But Fred does not reply; he sticks to the definition of his own identity and says: *"I am I. I don't care"*. Lea now expresses her identification with the mother she has lost: *"We suffered. It's my mother and me"*. In this short sequence, there is a hint of the heavy burden weighing on the dialogue between the siblings by the difference in their experiences.

Fred found a way to offer active resistance against National Socialism, but Lea faced a completely different situation. The history of events leading up to her emigration, as well as her time in England, are so connected with experienced humiliations and passive suffering that she still finds herself full of accumulated disappointments, wrestling with her emotional hurt. Her anger

is directed less towards Nazi Germany than towards the Zionist organizations which had the power to decide how (Palestinian immigration) certificates were to be distributed. In her interview<sup>103</sup>, we gain insight into the difficulties a Jewish woman faces if she wanted to leave Germany. For instance, her parents submitted an application to a Jewish organization to have Lea adopted by a Jewish family in America; Lea's passport photo was attached to it. Lea says that she was turned down because she was considered to be too "ugly." When Lea speaks of this, one senses her despair even today. The themes of 'experiences of rejection' and 'feelings of inferiority' permeate the entire interview. Referring to the time she spent in a training camp doing job training prior to being sent to Palestine as member of the Youth Aliyah, she says that a physician found her to be too slim. To Lea, a girl in mid-adolescence, this was an extreme humiliation. In the interview, full of accumulated aggression and hurt, she characterizes her experiences of rejection as comparable to the Nazi "selection procedures": *"I would not say this to a camp survivor, but this doctor ((who judged her to be too slim)) to me resembles doctor Mengele in the camps who said this one shall live and that one shall die; for me the fact that I was not allowed to go to Palestine was just like a selection ...."*

Seen in the context of this declaration, which she formulated from her present perspective, Lea's problem caused by that rejection becomes clear: *"I was terribly ashamed to return home because I became- the- I feared my parents would not believe that I ((hesitates)) ah- that it was not my fault, that perhaps I did not study hard enough...."*

In her further statements, she again stammers and shows much emotion regarding her fears and reveals, as in many other parts of her interviews, the presence of sibling rivalry. It hurt Lea that she, unlike her brother, was not "selected" for the Aliyah: *"Am I worth less than my brother?"* The feeling of being less worthy and less preferentially treated than her sister was reinforced when, on top of it all, her mother registered her sister for the children's transport before Lea. In connection with the theme of 'hate', that we have discussed initially, she says: *"I was very angry that my sister was put on the list and not I. But this was anger not hate."* In her individual interview, too, we can read between the lines that she was furious primarily because her mother had initially only registered her sister. At that time, Lea had been almost too old for the children's transport. Only through her connections to Zionist circles did her mother succeed in having Lea put on a transport list, too. This initial constellation had consequences for the way in which Lea copes with her past and mourns her mother: her mother had saved her life, but later on, while in England, she was unable to help her mother. Due to this constellation, Lea still has to deny any negative feelings towards her mother and also

---

103 She already had been interviewed in 1991 by Gabriele Rosenthal. Through Lea, the interviews with the other family members could be arranged.

finds herself blocked in her attempts to mourn her mother's death<sup>104</sup>. Lea does not allow herself to admit, much less voice, either her anger towards her mother or her feelings that her mother treated her less favourably than her sister. She also cannot admit the feeling of having been abandoned by her mother. Instead, she displaces her anger onto the Zionist organization to which her mother belonged. In the family interview, Lea and Fred are asked whether they had a question to put to their mother that they would like to verbalize. When Fred then asks: *"Why did you not emigrate during the 20s?"*, Lea emphatically rejects this accusation against her mother by stating excitedly: *"You know this very well, they were too poor."* Yet she has more or less the same question for her mother: *"Why are you not here?"* While Fred is able openly to direct a reproach at his mother, Lea vehemently wards off the reproach that her mother had abandoned her. Other case studies, too, demonstrate that women, in particular those who lost their mothers during adolescence, tend to suppress their rage against their mothers who were unable to protect them; and in this context, they put the memories of their mothers, so to speak, into a "deep freeze". (cf. Wardi 1992, p. 53ff).

In every encounter we had with Lea, as in her biographical writings and poems, her main concern is to present an extremely positive picture of her heroic mother. Thus, she makes a point of calling her - even in the presence of her brother - "my mother." Only when we come to the conversations we had with her brother do we pick up faint signals of the mother's pronounced ambition and of the hurt this caused Lea. She was not a very sturdy child and was thus unable to live up to these challenges. Lea recounts that her grandmother had defended her from her mother. We may assume that, after her grandmother left the household, the already difficult life situation of the family became markedly worse and conflicts with the mother multiplied. A family atmosphere full of conflict, probably exacerbated by the mounting threat to the family during the years 1937-39, and the rejections Lea experienced are a significant biographical constellation in her life. This is a contributing factor to Lea's obsessive occupation with the memory of - as she puts it - her „courageous mother“.

We may assume that Lea also stresses her own experiences of rejection in order to mitigate her guilt feelings toward her parents. In this sense we also interpret the stories she tells about the time she spent in England, which she describes as being very unhappy. In complete contrast to the manner in which she talks of Germany, she rejects England entirely whenever she mentions. Even today, she can hardly make the British perspective her own:

*"... As for the war, they first scared us ... they gave us gas masks and told us not to go too far away from home because German parachutists might come ... ..if they were to find us they would eat or massacre us... we also*

---

104 To the processes of mourning, see Bowly 1961; 1980.

*were not permitted to speak German....they tried to convince me that I should feel ashamed to come from Germany..."*

Lea also greatly stresses how lonely and unhappy she was in England, and only indirectly do we learn about other phases and experiences in her life there. She fell in love with the leader of her children's transport, a young man with whose family her parents had been acquainted and whom she married as early as 1941, when she was eighteen years old. The description she gives of her married life does not tally, however, with that of an unhappy and lonely life.

Her mother sent many loving letters to Lea in England in order to motivate her to learn and work, and asked her again and again to help her get a visa. But Lea found no one who would give her the money her parents needed to buy the 'capitalist's visas' so they could settle in Palestine. What a burden it must have been for Lea to receive, month after month, news of the ever-intensifying persecution of Jews in Germany and to learn that her parents had been transported to a concentration camp, without being able to help in any way. Her mother wrote, as early as in April of 1939, after her father's request for a certificate was denied due to his age: *"Our fate seems to have been decided. We shall not get to Eretz Israel."* In the same letter, the mother explained that she was now willing to emigrate to any other country and asked her daughter to try getting them a British visa. She closed the letter by saying: *"Stay healthy and don't forget your parents"*. Lea was thus given the delegation of helping her parents and not to forgetting them. By invoking time and again the memory of her parents, Lea desperately tries to do justice to at least part of this delegation. In her letters, the mother also asked Lea to look out for her little sister Nadja, who was living with foster parents in London. As Lea remembers it, her mother wrote: *„It would be our (Lea and Fred's) duty to look out for my sister. Yes and - I was fifteen years old and they gave me so many duties."* In that situation, Lea felt that her mother was asking too much of her and in search of help, she wrote to her brother in Palestine: *"I implored him to do something so that I could get away from there, so that I could get to Palestine. I implored him; otherwise I would perish; if he were not to save me I would die emotionally and spiritually"*.

As the mother in her desperation asked her daughter for help, the latter asked for help of her brother. Nadja, the little sister, was excluded from this family dialogue in which the members asked, and also received, mutual support. In the dialogue with her parents, Nadja depended on the exchange of letters between Lea and their parents. One of the reasons for this was the fact that she had forgotten her mother tongue. From our conversations with her, we can conclude that at that time Lea considered Nadja a burden and took little care of her, the delegation to stand by Nadja, as if she were her mother, being too heavy a burden for Lea. At that time, Lea herself had hardly outgrown childhood and being stranded in England, she, too, felt herself aban-

done. Due to this difficult situation, Lea, unlike Fred, is not close to her sister. The family interview to which we jointly had invited Fred, Lea, and Nadja took place without Nadja. She was unable to find time for it. When we asked Fred and Lea, what the absence of their sister meant to them, Lea immediately answered: *"it is a pity, but also a relief"*. It is a relief for Lea not only because she gets along so well with her brother, but also because she competes with her sister for her brother's affection. *"Fred compares between us"* she says, and he vehemently objects to this statement. Finally, it also is a relief to her because Lea has guilt feelings towards her sister. In talking to her brother, she says: *"Of us three, Nadja had the most difficult time. I was her only hope."* Nadja had the most difficult time of managing in England without her parents. From the perspective of Nadja, Lea already was an adult woman at the time they emigrated; in 1941, Lea was already married. From Lea's own viewpoint, however, she was still a young girl who missed her parents and found what was expected of her to be too heavy a burden. Lea reproaches her brother, indirectly, for not having been more supportive of her: *"I did not understand: Why did he not write me more often? Why did they dare arrest him?"* While Lea seeks a symbiosis with her brother and still longs for his support, Fred distances himself from both his sisters. He stresses again and again the difference between himself and them. He describes himself as a soldier and concentration camp survivor, who - as he stresses - has passed on to his children something different from what his sisters have passed on to theirs. He is closer to Lea because she grew up with him; Nadja is considerably younger. But he resists Lea's need to monopolize the family history prior to their emigration for herself, in particular as far as their mother is concerned. He, like Nadja, complains in both his individual and in the family interview that Lea always speaks of "my mother", though she was his and Nadja's mother as well. Fred is also sceptical regarding Lea's lecture tours to Germany. Lea has the need to be loved and accepted, in particular by Germans. We, the German interviewers, experienced this ourselves, and we also can infer this from the message she delivers wherever she travels in Germany. She takes the initiative in addressing young Germans, who feel guilty, and explains to them that they are not responsible for the Shoah. What matters to her is the opportunity to talk again and again about her family and - most of all - of her "heroic" mother. In her lectures, she reads from her mother's letters. She has also written a poem about her "courageous mother" from which she recites on these occasions. As primary proof of her mother's courage and heroism, she mentions the fact that she did not abandon her father. Thus she writes: *"Her mother's heart was deeply affected and tormented by the separation from the children she loved; but the true sense of being a spouse never allowed her to think of leaving behind the man she loved. They were very devoted to each other and went together to their death."*

These lines indicate that Lea subconsciously reproaches her mother for not having left her husband. Her mother had also informed Lea by letter that she could obtain a visa to work in England as domestic servant, but that her husband, due to his age, did not qualify for a visa.

Nadja, the younger sister, appears somewhat left out of her sibling's memories. To this day, her older brother somewhat condescendingly calls her '*Puppe*' (doll), which is also what her parents called their daughter. This indicates that her brother still sees her as a little girl. Certainly, to Fred, Nadja is more of a stranger than Lea, but at the same time he feels the need to defend her against her older sister.

The differences in the siblings' experiential world have been conditioned to a significant extent by their age differences and different personal experiences at the time they suffered persecution in Germany and emigrated from that country.

Nadja<sup>105</sup>, who came to England at the age of nine, is less tormented by guilt feelings about her parents than her siblings. Unlike Lea, she manifestly expresses her suffering over having been sent away from home to be on her own when still a small child; of this, she indirectly accuses her brother, her parents and - most of all - her sister. But just like her siblings, she has a need to idealize the harmony that existed during her childhood in their parents' home. At the very beginning of the interview, she stresses: "*Until today I remember that our parents didn't quarrel, at least not in front of us.*" It becomes increasingly clear how decisive this theme of "harmony in the parents' home" is for the family dialogue between the three siblings and for their manner of dealing with the past. We assume that the siblings strive to preserve the myth of a family free of conflicts, a myth that had already been established during their childhood. By means of this myth, they attempt to mitigate the significant differences noticeable in the intragenerational dialogue.

Within her foster family, Nadja had to confront an extremely difficult constellation. The father of this family had wanted to offer a safe haven to a Jewish refugee child from Germany, but he died a few weeks before Nadja could leave Germany. After that, his widow, who had two children of her own, did not want to accept an additional child and made this quite obvious to Nadja. Nadja felt herself "abandoned" by her own parents, unwelcome by her British foster family, and, most of all, a stranger in her new surroundings. Even today, one can detect traces of a child's defence mechanism which can also be observed with other children who were separated from their parents. They mourn the loss of their erstwhile material possessions rather than the loss of their parents. For instance, in the interview, Nadja does not speak of her longing for her parents but complains that she missed the books in her

---

105 Nadja was interviewed in Hebrew by Tamar Zilberman in 1994. Unlike her siblings, she speaks Hebrew with a pronounced English accent.

parents' home: *"In the entire apartment there were not half as many books as in our home. I was used to books; one does not need to eat but one needs books. Books are books. That really distressed me..."*

At that time, Nadja received little support from her sister. Once, when Lea visited her in London and Nadja complained about the foster family, Lea allegedly reproached her lack of modesty and her ungratefulness. But Nadja represses her disappointment in Lea and her brother. During the interview, she repeatedly asks that the tape be turned off when she complains about Lea. She describes incidents in her parents' home in which Lea had acted toward her in an unfair and mean way. Thus, she can talk about some of the incidents in which her older sister had made her suffer; but she is unable to talk openly, or with humour, about the past to her brother and sister. She tries instead to keep her disappointments and rage out of the dialogue between the siblings. What bothers her most about Lea is her sister's claim that Lea is similar to their mother. In Nadja's view, Lea's behaviour hardly matches that of her mother.

It is probably due to this conflict with Lea that Nadja avoided a joint family interview with Lea and Fred. Her brother shares this impression. In a conversation held with him alone after a joint interview with Lea, he mentions that Lea's presence had been the reason for Nadja's not being there.

Nadja left her foster family, when she was fourteen years old (in 1944), and moved into a home run by "Hashomer Hatzair" (at the time the most left-wing part of the Zionist movement). Thus, she was continuing in the family's tradition; but unlike her siblings, her political commitment has remained strong all her life. In 1950, she moved onto a kibbutz in Israel. A few years later, she did Zionist work on a boat that brought immigrants from Morocco to Israel. There she met her future husband, who also worked on the boat. He had succeeded in emigrating from Europe to Israel just before World War II started. Later, she moved with her husband and her two daughters to South Africa, where her husband had accepted a job. The family finally moved to Germany, again, because of her husband's work. The family lived there for many years, until Nadja got a divorce in 1985 and moved back to Israel where one of her daughters was already living. Her other daughter moved there in the spring of 1994. Nadja became politically active in the Zionist-Communist movement.

After the end of the war, Fred, too, became politically active in the Zionist movement. First he worked abroad for the Haganah but returned to Israel in 1945 to fight as a soldier in the War of Independence from 1948 to 1950. In 1946, he married a woman he had known during his schooldays in Berlin; the couple has two children. While the marriages of his two sisters broke up, he and his wife remained married until his wife's died in 1985.

We interviewed Fred's son and granddaughter. In the way they deal with the past, they resemble the children and grandchildren of the Arad family.



They, too, identify with Israel and the Zionist movement and split off their own life history from that of the family which was tied to the Holocaust. Fred's son Roni, born 1949, presents his father in the thematic field 'he was a soldier, fighter, and Zionist pioneer.' His grandparents are no more to him than the "parents of my parents;" they are strangers to him whom he reproaches for not having emigrated. He thinks that his grandparents failed to leave Germany in time because they had been very well off in that country and did not wish to expose themselves to Israel's primitive living conditions. In the way he presents himself, Roni is the typical Sabra who tends to deny his European roots and identifies with the "young and fragile state of Israel that one always must be ready to defend". Roni's daughter Shira (born 1976), the granddaughter of Fred, also stresses the present and declares that the history of the family prior to the Aliyah does not interest her.

In 1946, Lea and her husband immigrated to Palestine. The husband's mother and sister were also murdered during the Shoah. The couple moved onto a kibbutz and her daughter Ofira was born the same year. Only two years after Ofira's birth, Lea separated from her husband and volunteered for military service in the War of Independence. She argues that her husband had failed to support her in mourning her parents. In summary, she states:

*"I married him only because he, too, came from Berlin; he knew somebody my mother knew. And I didn't have anybody else. When my father died, - well, he reacted as if nothing had happened. Well, when that happened I somehow no longer felt the need to be with him. My parents were gone and he was not interested in anything; he never talked about his mother and sister..."*

Lea left Ofira in the care of a foster family and agreed to let her husband act in loco parentis. We may ask to what extent Lea, who had felt abandoned by her own mother, found the role of being a mother too much of a burden. The close connection between these two themes becomes very evident in the family interview<sup>106</sup> to which Lea and her daughter Ofira had been invited. Lea is hardly able to see matters from her daughter's viewpoint; Ofira feels abandoned by her mother. When this theme comes up, Lea is overcome by despair over her own mother's death. The interviewer asks Lea to convey to her daughter her own feelings at the time she was separated from her mother. Lea first argues that her divorced husband had used Ofira as a weapon to force her to remain with him. Then she begins to cry bitterly and step by step, she comes to express her despair over the loss of her own mother:

*„I know this has nothing to do with Ofira; it has to do with me because I had my mother not with me. She would have helped me, either to live with him or to overcome leaving him. But I felt so alone. I always was scared of*

---

106 This interview was conducted in English by Gabriele Rosenthal and Noga Gilad in 1994.

*being alone ((she cries bitterly)) ... I didn't understand why it was that my mother died. I was left alone and I didn't understand the world and all I wanted to I want to live for myself...."*

In 1950, Lea married a British Jew, Jonathan Ashkenasi<sup>107</sup>, with whom he has two sons with him: Rafi, born in 1951, and Shuki, born in 1952. She went back to school and graduated with a degree in social sciences.

In the following pages, we shall introduce the daughter of Lea and her family as well as the older son of Lea and Jonathan. We want to show how Lea's way of dealing with the past, that is, her obsessive reliving of the memories of her mother, affects her children and grandchildren; for these are aspects in which Lea differs significantly from the Arad grandparents as well as from her brother Fred.

### *The Kibbutz as a family: The Caspi family*

Lea's daughter, Ofira: the hole

Yael Moore

In the first generation, there was a separation which marked Lea's biography with endless longing for her mother, with enduring thoughts about her parents and about her childhood. Lea asked us to interview her daughter Ofira. What marks will Ofira carry from the family history?

Ofira<sup>108</sup> was only two years old when her parents divorced and she was given away to a foster family. During the years that followed, both of her parents remarried and established a family of their own. At the age of ten, Ofira's father got custody of her and she moved to live with him and his second wife. She was not allowed to visit her foster family. Having been separated from her parents at the age of two, and again taken away from the foster family at nine may have had a great psychological impact on Ofira. Separation at the age of two above all dislocates the process of individuation and separation, which can have consequences for the further development of a child's sense of autonomy (cf. Mahler 1965, Winnicott 1965). John Bowlby, who primarily explored the resulting separation anxiety, summarizes his findings as follows: "Throughout this period (six months to four years, Y.M.) I believe there is a danger that the child may be subjected to experiences which can give rise both to separation anxiety and to grief and mourning of an intensity which can dislocate the development of his personality" (1960, p. 13).

---

107 This interview was conducted in English by Wolfram Fischer-Rosenthal in 1991.

108 Ofira was interviewed by Gabriele Rosenthal and Bettina Völter in 1993. The interview was conducted in English.

Let us now look at the way Ofira relates to the separations in her life history: what biographical constellations have helped her work through the separations in her life? What kind of biographical work has she done? In Ofira's life story, there are many questions which centre around having been abandoned, and her sense of identity: whom does she belong to? why was she given away? *"I was not brought up by my mother..."* This is the opening line of Ofira's interview. The interview begins with a statement about Ofira's place as a daughter. Ofira begins by emphasizing what she lacked, and the abrupt break in the natural process. The fact, that she was not brought up by her mother, is a theme which deeply upsets her. She continues: *"...my parents they divorced when I was very young and I was brought up, till I was ten with a family eh, not my family, they needed good money for, taking care of me"*.

The line of association indicates that, as a result of the absence of her mother, Ofira grew up in a foster family. However, there is a hidden fantasy: Ofira wonders if the foster family took her because they needed money. She is not certain of their love, as perhaps economic interests were the reason for taking her as a foster child. She perceives herself as an object that one can take or give away according to one's interests.

Her place as a daughter is in dispute. Is she a continuation of her own biology family? or does she belong to her foster family? On the manifest level, Ofira presents herself belonging in the foster family: *"...I remember that I loved very much to go there ((to her father's place: Y.M)) and be with him but my family was the family I grew up with...from when I was two years old...I called them mother and father...for me they were my family..."*.

The foster mother also came from Germany and had immigrated before the war. Her parents were killed in concentration camps, as had been Lea's parents and the father's mother and sister. During the time Ofira stayed with the foster family, she occasionally visited her mother and father. On her visits to Lea, Ofira was continuously confronted with a feeling of emptiness, with a "hole". Each visit to Lea emphasized her having been abandoned by her family, shook her confidence in her belonging to one family and amplified her jealousy of those who have a stable family, a firm sense of belonging. She describes her visits to her biological family: *"...I did not live with my mother and I came only to visit...I remember myself...envying her sons...because they had a family and a mother and a father...they had a lot of fun...they had a lovely life...lovelier than what I had..."*

Ofira continues to suffer from this experience of loss even today and struggles with feelings of distance and closeness to her mother. This became particularly clear in the family interview, which we had invited Lea and Ofira to attend. Ofira oscillates between her need to underestimate the importance of Lea in her life and the recognition of the "hole" which her mother's absence left in her. Thus she tries to argue: *"between me and my mother, I don't think about it too much"*. And two minutes later, Ofira asks: *"How can a mother*

leave her daughter?" And when Lea answers that she herself had no mother, Ofira says: *"The lack of her mother is stronger than the lack of me"*. Ofira can bear listening to her mother when she talks about her experiences of loss. She left the room when her mother started to cry desperately over the loss of her own mother. At the same time in another room, Ofira was crying desperately over the renewed rejection by her mother. Ofira, by attempting to exclude Lea from her thoughts, not only defends herself from her pain, but also somehow takes revenge upon her by refusing Lea her place as her mother. Both the defence and the need expose Ofira's continuing pain and anger about having been abandoned. For Ofira, the pain brought on her by Lea's absence cannot be healed: *"My soul is broken there...this part did not heal ((the absence of Lea)) it will stay, I think it will stay broken"*.

In her biography, grief at the loss of her mother is mixed with grief at the added loss of her foster mother. At the age of nine, Ofira's sense of belonging and being emotionally connected was interrupted again. Once again she lost a mother. As Winnicott conceptualizes: *"...trauma is the destruction of the purity of individual experience by a too sudden or unpredictable intrusion of actual fact..."* (Winnicott 1965). Ofira's natural growth was exposed at least twice to such intrusion. Presumably the second intrusion laid open the first trauma, the first abandonment. Thus old pains and sufferings perhaps unconsciously appeared again: *"I had a happy childhood with my foster mother. I loved her very much, I think she loved me too...I was a happy child (1) only after that, when my father got married, then all my bad feelings started"*

The separation from the beloved foster mother and family to go to the new wife of her father left scars:

*"...to say good-bye is the hardest part for me I cry for weeks, uh, it tears part of me- separations I think it was the main mistake and that made my life very hard, I always wanted to go back to that woman who was my mother ((the foster mother: Y.M))...I couldn't- all this made the other woman ((the father's wife: Y.M)) ...I don't love her..."*

In the interview, Ofira says little about the phase of her life she spent with her father. Her life afterwards has more biographical relevance for her. Graduating from school and entering the army at the age of eighteen represent a biographical turning point for Ofira. This was the beginning of a new phase in her life, in which she found a new home on the kibbutz, a replacement for her family. Ofira went to the army in a special program which integrates army and kibbutz life, the Nachal. She lived on the kibbutz, where she met her future husband Eliezer Caspi. Ofira stayed on even after she had completed army service and at the age of 22, married Eliezer. The couple have six children, five sons and one daughter.

The oldest son was born in 1969 and the youngest child in 1981. Thus Ofira fulfilled a wish she had had since childhood: *"We got married when I*

was 22 and I knew that this is the most important thing for me to, to build up a family and a big family".

Ofira, as a means to repair her own childhood, surrounds herself with family. She, as an adult, tries to fill up the "hole" caused by the absence of her mother, of a consistent family. The kibbutz and her big family are layers of protection against the lack she feels. Ofira turns to the places and the structures which give her the love and the sense of belonging she has longed for.

After her marriage, she went to university and studied education. After she graduated from university, she worked as a teacher.

embedded in Ofira's life history, there is a repetition between generations: just like Lea and her husband, Ofira was separated from her parents. Like Lea, she longs for the love and belonging which she was torn away from. However, her life history, especially her present life, indicates that Ofira, by having a big family and living on the kibbutz, is trying to repair the traumatic course of her life. The way she presents her biography reveals her psychological investment in the past of her family, in the Holocaust. Throughout her interview, Ofira exposes her preoccupation with the question of her being abandoned, with fantasies about her grandparents, with her lack of belonging. As derivative to the question of belonging, she is deeply occupied with the murder of her grandparents, with the Holocaust and her lack of knowledge as a child: "...as a child I knew nothing except for that they were all killed...".

The lack of knowledge can symbolize the lack of roots. By being put with a foster family, Ofira was not only abandoned but also disconnected from her history and roots. Having no knowledge opens the way for fantasies. Ofira can remember that already as a child she fantasized about the Holocaust:

*"and then my father got married and took me. I suffered a lot because I felt always that I'm not one of the family. I pity myself I used to tell myself eh-you know how children suffered in the concentration camp they had nothing, I used to tell myself in order to calm myself down".*

It is not only that Ofira comforted herself by relating to her suffering only as relative, but it is also that through these fantasies she could have some sense of belonging. She compares the tragic course of her life with the children in the concentration camps, she identifies with them: like them, she felt deserted, "had nothing".

As the analysis of the interview elucidated, Ofira entangles three themes together: her grandparents' death in the camps, her feelings in her family, and her fantasies about the children in the camps. The thematic field of her life story might be formulated as "my grandparents in the camps and my own suffering". Thus, she does not relate to her mother's suffering. She separates her parents from the Holocaust, while she locates herself in the Holocaust. Her identification with the children in the camps, especially her loneliness, is exemplified in the following text:

*"You know in, the pictures of Muselmen, children and hungry children and suffering children and orphans and children wandering around by themselves without grownups- Children (2) that, cannot walk, cannot talk, can hardly do anything, have nothing, no no parents no no family no nothing, this is the kind of picture that I do remember"*

In Ofira's fantasies, children and old people are in the camps: *"I could never understand how can they leave those children, old people, how? What gave them the strength to live? I wouldn't be able to go through it, I remember thinking about it and going to electric fence."*

It is a question what Ofira means by *"they leave those children, old people"*. Presumably she is thinking of the young adults who were separated from the old people and small children in the selection. Perhaps she is unconsciously referring to her mother here and perhaps to her father, too, who abandoned Ofira's grandparents. Ofira certainly believes she would be unable to continue living in a situation like that.

Yet, another aspect of this is that Ofira locates herself in the concentration camp with her grandparents as an unconscious attempt to heal the enduring trauma of her mother. Lea feels guilty about the death of her parents. In her interview, she relates to their lonely death. By presenting herself with her grandparents, Ofira does not leave them to their own fate. Ofira in her fantasies is together with her grandparents. Thus, she puts herself in the second generation, taking the place of Lea as the daughter of her grandparents. Being in the Lea's place, she cannot take her perspective. This fantasy is also hinted at when Ofira describes the letters Lea received from her mother:

Ofira: "It was very touching ((the letters, Y.M)). I told my self I wished my mother would write to me such letters, she ((the grandmother, Y.M)) loved her so much, warm letters".

Interviewer: "And you wish she were your mother?"

Ofira: "Maybe".

In order not to feel the pain, Ofira imagines her grandparent's death to be brought about by "natural" causes. Thus, she describes the journey to death like a trip to a foreign country, guarding the grandparents' honour and dignity:

*"I can see them when they were called out of the houses. They looked very, dignified appearance, even in bad times they still remained human beings and you know, dressed up nicely, going to the train, going down the train, into the huts that they were supposed to-. My grandfather died, I think he had a heart attack or something, he died in Theresienstadt. I see my grandmother broken-hearted by this and, I think she just she broke, she broke, ah mentally-. This is the way I think about her, I think that she did not stay long in Auschwitz, she was sent straight to- "*

The interviewer helps Ofira to formulate the cause of the grandmother's death: "to the gas chamber" and Ofira answers: "yeah, to the gas, I think so."

This process of minimizing imaginings of the Holocaust appears many times in Ofira's interview. In the beginning of the interview, she argues that "my grandparents were killed in the war". Later on she argues: "*When I was a young girl in school we didn't talk so much about this. We knew that things happened, most of the people thought that the Jews did not do anything in order to fight against the situation.*"

At this point, Ofira brings up her uncle Fred, in order to make it clear that she, too, has a fighter in the family: "*He fought against the Nazis, against the German army*". It is not only the pain that hinders Ofira from naming the act of murder, it is also the atmosphere of shame into which she grew up. Being gassed to death is merely helplessness, and she hurries to present the antitheses: her fighting uncle Fred. Thus, she, like many of her generation, seeks this heroism as a means of escaping feelings of helplessness, pain and despair. She is somehow ashamed of her relatives' fate, since they do not belong to the myth of the "strong and fighting", as her uncle does. Moreover, the Holocaust survivors have some frightening features. Ofira recalls how on her visits to her mother she was afraid of being grabbed by survivors on the way. She stammers as she speaks of this:

*"I remember very tense very:- a lot of uhm, uhm, a lot of uhm (1) uh people that uh , uhm , uh, uhm (2) uh how to say? a situation where, older people he, grabbed uh young a girls you know, people that came from the camps, uh that were a little crazy, part of being afraid, uh to go by myself."*

As a child, Ofira was not certain if her grandparents were dead. She had a fantasy that perhaps they would come back and take her with them. In this fantasy, there are a few different aspects: on the one hand, there is the frightening feeling of Ofira being taken away again. Yet there is also the hidden wish to belong, to have a family, to be the daughter of her grandparents. It is no wonder that these fantasies appeared when Ofira visited Lea: these times were full of sorrow, and the lack of her mother was magnified. Ofira then frightfully imagines "*people who came from the camps...*" taking her away. She also imagines them as crazy, insane, thinking that something in the camp made them insane.

According to Ofira, Lea never talked about her parents' death, "*only about their lives before the war*". Is it possible that Ofira, in the described fantasy, takes part in her mother's fantasy that the grandparents are still alive?

#### Concluding remarks

The centre of Ofira's life story is the "hole": it is this emptiness that she tries to fill by fantasies of belonging. The gaping hole was the metaphorical testi-

mony Lea left Ofira. Ofira makes efforts to minimize the power of Lea's testimony, yet this testimony acts as if it has a gravity of its own. Latently, and continuously, Ofira tries to deal with the results of the family history, with their traces in her own biography. She tries to heal and repair her pain by fantasies, reasoning and concrete acts. By "reading" again and again the testimony of her parents and grandparents, she tries to symbolize and formulate the "hole", she is thus also connected to the family history, she belongs to the family. Her place as the daughter of her grandparents softens her having been abandoned. Although by this, she unconsciously expels her mother from her place as a daughter, she evokes Lea's fantasies and unconsciously attempts to calm her mother's guilt feelings over her parents' death.

The metaphor of the "hole" is an inheritance which continues from one generation to the next. It is the testimony of the absence. It cannot be overlooked. Thus, Ofira wonders about the testimony she transfers to the next generation:

*"Children that were beaten, will be beating parents, she was torn from her family and this made her behave that way, eh when she became a mother, really got married too young. And that's all the similarity because I, I've decided that because I didn't have-, I'll be different, maybe my kids have, a lot of criticism about me and my upbringing, something that I can't help everything must be organized".*

We would like to make a few remarks concerning Ofira's half-brother Rafi, the oldest son of Lea and Jonathan, before we take up the story of Ofira's husband and their sons Tomer and Chen: similarities exist between the case of Rafi and that of Ofira; the life histories of both have been affected by the family history on their mother's side and by the effect that Lea's inability to mourn had on her children. Just like Ofira, Rafi does not avoid confronting the facts of his family's history in Germany and the murder of his grandparents. Rafi<sup>109</sup>, who was born in 1951, presents himself as well as his father Jonathan entirely in the context of the family history of his mother and of Ofira. Generally, he finds it difficult to talk about himself; instead, it is his mothers' family history that forms the thematic horizon of his biographical self-presentation. In a way, he refuses to admit even that his maternal grandmother is dead. For many years, he had looked forward to the day when she and other family members would finally arrive in Israel: *"For years I still waited that someone will knock on the door. But they ((the grandparents)) didn't make it in time, couldn't escape."*

There is a slight hint that in the case of Rafi, just as in that of Ofira, he is a little afraid of his hopes coming true. Unlike his half-sister Ofira, Rafi does not visualize his grandparents and himself in a concentration camp. Rather, he

---

109 Rafi was interviewed in 1993 by Noga Gilad, in Hebrew.



fantasizes about an unsuccessful escape attempt by his grandparents prior to their being sent to Theresienstadt.

For Rafi, it is important to be always prepared for an escape. Continuing the above quotation, he says: *"this was strongly imprinted in me and I know I am on alert, 24 hours all my life, on alert that if something happens I sur- I have all I need for survival."*

Ever since he was a child, the wish to develop the ability to escape was important in shaping his life history. When he was only twelve years old, Rafi, without informing his parents, went on a hike for several days along with his younger brother. They slept in the open. Survival tests on trips of this kind became his hobby. While Ofira thus has looked for protection by choosing life on a kibbutz and establishing a family, her younger brother, so far, has established no lasting relationships, has no fixed commitments, and is always ready to go away, or even leave Israel.

Rafi is aware of this difference between himself and his half-sister. He recounts that Ofira, when only ten or twelve, used to say on visits to the family *"how important it is for her to have a family, and she will have a big family with about 12 children"*.

In the ways they cope with the murder of their grandparents, Rafi and Ofira differ considerably from the second generation of the Arad family. The latter refuse to mourn; their thoughts and feelings are governed by their present and future life in Israel. Rafi and Ofira continue the mourning process of their mother. While Lea still deeply grieves the fact that she was abandoned, her children try to cope with the persecution of their grandparents (in the case of Rafi their being sent to a concentration camp; in the case of Ofira the time they spent in that camp). Their case, just like that of the Arad children, shows that the grieving process does not necessarily come to an end during the lifetime of one person but might continue, step by step, from generation to generation. First, Ofira approached the theme in the form of "old people in a concentration camp"; to her children this meant that they had to follow in her footsteps by accepting the burden of "murder of the grandparents."

### *Eliezer and his sons: to stay on the kibbutz or leave it?*

Noga Gilad and Gabriele Rosenthal

Eliezer Caspi: Bound to the kibbutz. Eliezer Caspi<sup>110</sup>, Ofira's husband, was born in 1946 on the kibbutz Ma'ale Hagai<sup>111</sup> which is located in the north of Israel near the Jordanian frontier. At the age of 22 and 24, his parents, to-

---

110 Eliezer was interviewed in 1994 by Noga Gilad, in Hebrew.

111 In order to protect the anonymity of Eliezers' kibbutz, we have substituted the name of another that resembles it.

gether with a group of young Zionists who all came from the same town in Eastern Poland, had emigrated to Palestine in the year preceding the beginning of World War II. Two of his father's brothers also belonged to that group. In Palestine, these young pioneers played a key role in the development of Ma'ale Hagai, and Eliezer's father was among the men who took over the leadership of the kibbutz.

Eliezer was socialized within this group of Zionist pioneers. For him - as probably for other children of his generation - this group represented a kind of substitute for the family members who had remained in Poland, as well as for the grandparents who all were murdered in the Shoah. Eliezer, just like his wife Ofira, belongs to those of his generational unit who did not distance themselves psychologically from their families' past prior to emigration. As a child, he had already been greatly interested in the Jewish community of his parents' home town and in their life in pre-war Poland. Now himself father of grown children, he is preoccupied with the question of how it was possible that his parent's generation left their parents behind in Poland? Not until his father and one of his uncles had died did Eliezer have the courage to ask his father's last surviving brother the question to which he had always been seeking an answer: "*what did you feel in your heart?*"

While the central question Ofira wanted to ask her mother was 'how were you capable of abandoning me?', Eliezer asks his parents this question in reverse. In the family dialogue of the Caspi's second generation, two problems have now merged: the abandonment of children by their parents and the abandonment of parents by their children. It is interesting that Eliezer sees a parallel between the abandonment of the grandparents in Poland and the action of his two oldest sons, who have left the kibbutz. By doing so, Eliezer on the one hand puts his parents' behaviour on the eve of World War II into a less dramatic historical context. On the other hand, he dramatizes the action of his sons in leaving the kibbutz. In this, there is also a bit of admiration in the way he looks at their choice. Again and again, Eliezer talks admiringly of what his parents did - perhaps in defiance of the grandparents' wishes - deciding to emigrate to a distant, unknown country where, later on, they did significant pioneer work. While his parents and his two oldest sons have uprooted themselves, Eliezer is the one who has remained on the kibbutz and has made the emulation of the pioneer generation the purpose of his own life, a goal he never will be able to achieve.

Unlike Ofira, his wife, Eliezer rarely confronts the problem of the Shoah and the murder of his grandparents. He thinks his parents never tried to find out anything about the fate of his grandparents. Whenever he touches on this theme in the interview, he veers toward two other themes: "My parents' Zionism" and "I, a Sabra and kibbutznik." The analysis of his biography makes evident his complete concentration on life on the kibbutz and his strong ties to it. We may assume that his commitment to Zionism and to life on the kibbutz

help Eliezer to avoid grieving the loss of his murdered grandparents, or help to mitigate that grief. In this, Eliezer's case is similar to that of other members of his generational unit. It is typical for his generational unit that after Eliezer has been asked to relate the family history and his own, he starts the interview by saying: *"I was born in the country, on a kibbutz."*

His early socialization on the kibbutz was decisive in shaping the course of Eliezer's life. As a small child, he experienced the 1948 War of Independence. Bombardments completely destroyed the Ma'ale Hagai kibbutz and many people died. After that, the kibbutz community was evacuated to a town beyond the danger zone. At the end of the war, the kibbutz community split up. Some of the kibbutzniks, including the family Caspi, returned to Ma'ale Hagai and rebuilt the kibbutz, while others decided to establish a new settlement far away from the frontier. To this day, Eliezer considers this treason against the ideals of the kibbutz movement. In general, commitment to the kibbutz is Eliezer's main theme in the interview. Likewise, the description of his childhood and youth as well as of the difficult times in Ma'ala Hagai, which did not come to an end until the victory in the Six Day War in 1967, completely centre on this theme. The themes of 'fear', 'loneliness', and 'lack of attention from my father' can only be detected "between the lines". Asked to tell more about his childhood, he speaks of the nights when the children were alone in the children's house on the kibbutz<sup>112</sup>. It comes as a surprise to Eliezer when he now remembers that, up to the age of nine or ten, three or four of the children snuggled up in the same bed. The reason for this is not quite clear to him, a grown man with six children of his own, the older ones of which also slept in the children's house, away from their parents: *"I really don't know if it was fear or not...I still can't understand the reason for it."*

At an other point, he is able to admit his fear but must stress that the other children were also afraid:

*"When one would come to Ma'ale-Hagai, it was dark there- I remember as a child it was dark. We were scared, there were only a few street lamps... we were frightened to go, and we were a frontier-settlement, we were by the border, the children's houses were 100 meters from the fence, and I remember we were really scared, but I was not the only one (2)"*

---

112 It was the custom in most kibbutzim until a few years ago that the children spend the nights in the children's house together with others of the same age. They joined their parents only in the afternoon after school.

Again and again Eliezer brings up the theme "my commitment to the kibbutz" and mentions his father in this connection. He introduces him as a figure in the public life of the kibbutz and not as one who has a role in Eliezer's family. The interview only indirectly permits us to assume that Eliezer wished for more closeness and security. Here it should be noted that his childhood memories centre on the theme of "loneliness." He thus tells us, for instance, that in the kibbutz he took care of lonely animals.

At times, Eliezer came close to considering the possibility of leaving the kibbutz. This happened during his adolescence and when he did his military service in the "Nachal" unit where he met Ofira. However, he returned to the kibbutz where he started a life of complete commitment to the community, and he endeavoured to overcome the formidable economic difficulties, which the kibbutz confronted. When he made this decision, he was the same age his parents had been when they left Poland. In talking about this phase in his life, Eliezer compares it with the one in which his sons are now:

*"In 1967 I was 21 years old, today I have three children over the age of 20....I say I in their age decided, that's my direction and I won't go to these pleasures of youth where - who would mention travelling abroad at all,... I bound myself body and soul to build the- farm and all in all I was a child."*

By stating his position as one who 'bound myself body and soul to the kibbutz', Eliezer also gives expression to a certain ambivalence. In a way, he gives permission to his sons - he actually delegates this to them - to leave the kibbutz and enjoy life more fully. For him, being 21 years old is associated with the idea of his parents, though, as mentioned before, they emigrated when they were already 22 and 24 years old. *"These parents, twenty-one years old, got up and left their home....and decided we are immigrating to the land of Israel."*

At the age of 29, already married and father of four sons, he started to study economics. But little more than a year later, the treasurer of the kibbutz left and he was asked to accept the post. Seven years of hard work now lay ahead of him. Eliezer accepted the post and continued his studies whenever he found the time. When Eliezer talks of these years, he sounds like a general who conducted a war against Ma'ale Hagai's financial problems and finally won. He compares his vision of the future with that of Theodor Herzl in spreading the vision of a Jewish state. As an example, he recounts the following story. In the summer of 1976, he was standing in front of the swimming pool which then was under construction, when an old lady voiced the opinion that this job would surely not be finished soon. Eliezer's answer was: *"Herzl visualized the State of Israel fifty years before people saw it, he saw it is possible. I also see the swimming pool ready on time, it is possible."*

In the '80s, Eliezer became the head of the kibbutz. He relinquished this position some time prior to this interview. As he tells us, now, finally, he

could dedicate more time to his children. But they were now ready to leave the kibbutz: *"Of course I would like them to stay on the kibbutz,...I want it for the kibbutz. I know that they can manage and all, but, I see it as, with them one can build a better society, with such people."*

He argues that he will not set any rules for his children and leaves the decision up to them.

What effect does the ambivalence of the delegation, to stay on the kibbutz or leave it, have on the children of Eliezer and Ofira? What marks are left on them by the themes: the parents leave their children and the children leave their parents? And how do they live with that part of the family history that happened prior to emigration? To go into these questions, we present two sons of the Caspi family. Tomer represents the type of the third generation kibbutz children who have left the kibbutz and care little about the family's past. His younger brother Chen, however, is still living on the kibbutz and is very interested in the Jewish community in Poland to which his father's family had belonged.

Tomer Caspi<sup>113</sup>: "Getting out of the commitment". Tomer, born in 1970, is the second son of Ofira and Eliezer. Noga Gilad interviewed him a few days after his younger brother Chen. Tomer participated in the conversation very much against his will and explained his reluctance as follows: He has very little to say regarding the family; it is a subject about which he does not know much and which does not interest him. He has always disliked dwelling on the past, as he had been obliged to do, for instance, when he had to write his "roots papers". What little information he has concerning the family history is limited to the age of the person in question and the dates when his grandparents left their parent's home. We assume what matters to him is the theme: when does one leave ones parents or the community. In this he resembles his father.

Tomer speaks of his grandmother Lea in an ironic tone, like somebody with whom he is not personally involved. To his knowledge, she started *"that business of her mother's letters"* and going on lecture tours in the early 1980s. When he was fifteen years old, Lea organized a family reunion. On that occasion, she showed them a family tree and asked if anyone had more information about the family. Tomer explains that since then he is tired of listening to her stories. But while he feels sympathy for Lea and his maternal grandfather because of the losses they have suffered, he talks cynically about the Caspi family history and makes fun of their "Zionist pioneer" myth. After all, he is the one Caspi who rejects the family's Zionist delegation of commitment to the kibbutz movement.

Just as in the case of his father, the turning point came for him during his military service. But unlike his father, he decided to leave the kibbutz: *"I was*

---

113 Tomer Caspi was interviewed in 1993 by Noga Gilad, in Hebrew.

*searching for myself (2). I left the kibbutz after the army. I was some two months in Tel Aviv then I travelled a bit, I returned and at the moment I'm in a transitional period".*

He also mentions that even during childhood he wanted to get away from home: *"I wanted to run away from home at a young age, we had such a duffel bag I remember that once I started to pack in order to run away...perhaps I'm making it up but that is the story"*

Unlike Tomer, his brother Chen feels there are close ties between his life and the family history.

Chen Caspi: Searching for the roots. His mother Ofira had suggested Chen as a suitable interview partner. The family considers him to be the one who has looked into the family history more than anybody else. The most remarkable aspect of the interview with him, which was conducted in 1993 by Noga Gilad and Tamara Zilberman, is the difficulty Chen has to condense his narration to its essentials. It is an obsession of his to describe the most unimportant details. He talks in a very fragmentary fashion and often stops in the middle of a sentence, especially when he touches on problematic themes. Very much like his father, Chen concentrates on the theme "commitment to the kibbutz and life in Israel". It is interesting that Chen, quite unlike Tomer, is interested in the names of persons but less so in dates. To him, only the 1948 War of Independence qualifies as a date of historical importance. We shall explain the significance of this later.

The interview with Chen took place a few months before he finished school and shortly before he was drafted into the army. About a year after the interview, while in the service, he suffered a psychotic phase and had to be hospitalized. He was discharged from the service and now once more lives with his parents on the kibbutz. We do not want to undertake an interpretation of this, and discretion requires that we dwell neither on the details nor on the nature of his delusions. But it caught our attention that in the case of all the Caspis whom we interviewed, their military service coincided with a biographically relevant turning point in their lives. Ofira moved to a kibbutz, met Eliezer and found a substitute for her family. To Eliezer and Tomer, military service was a time for reflection on their commitment to the kibbutz. At first sight, this cannot be considered of major importance because all kibbutzniks confront this problem during their military service. But it attracted our attention that this phase is of great significance in the biography of every member of the Caspi family.

Let us look more closely at Chen's actual life history and the way he narrates it. Chen starts the interview by giving exact data about the places and geographical areas of his grandparents' origin. He possesses more information concerning the family of his mother than that of his father. What bothers him most is the fact that he knows nothing about the fate of his paternal great-grandparents and his other relatives in Poland. Chen ends his story by narrat-

ing the life history of his uncle Fred who volunteered to serve in the British army. The thematic field of the presentation of the family history prior to coming to Israel could be summarized as follows: "parents stayed and were killed, children decided to emigrate and left." This indicates that his father's question, "how was it possible that the children abandoned their parents", creates a dilemma for him. After this report, Chen starts to narrate in great detail the history of the family in Israel. The way he sees it, the Shoah had less of an adverse effect on the family history than the 1948 War of Independence. He begins the story of this phase of his parents' life with the remark "With no connection to the Holocaust." Within the thematic field of "my parents who were not involved in the Holocaust", he reports that Ofira, his mother, grew up in a foster home and connects this with the 1948 War of Independence: *"After two years then they were drafted. It was the War of Independence, mother was born in 46 and the War of Independence was in 48, grandpa drafted, grandma Lea volunteered. So they gave her to a foster family and in the meantime they divorced (2)"*

For Chen, Ofira's experience of loss is thus related to the commitment of his grandparents to the State of Israel. He has a similar explanation for his father's feelings of being neglected by his parents. Chen interprets this neglect as a consequence of his grandparents' commitment to the kibbutz. The War of Independence and the reconstruction of Ma'ale Hagai also play a major role in his presentation. Chen idealizes "the full commitment to their ideals" of his paternal grandparents. Nevertheless, he also takes the perspective of his father. He starts out by saying that his father had a pleasant childhood in comparison with that of his mother, but then he continues: *"He had a well-arranged childhood, but even he altogether, according to my judgment it's a childhood of a terribly busy father, that managed also to rebuild a kibbutz from 48 kind of because not many had remained."*

Chen is ambivalent about his father's childhood. On the one hand, he sees his father as the child of a pioneer; his childhood was properly structured. On the other hand, he observes that his father felt neglected. This is also Chen's own dilemma.

Let us now look at Chen's own biography: He was born in 1975, the fourth son in a difficult family constellation. His father was busy with his studies, and his grandfather was on his deathbed. Chen mentions that due to the care they had to give his grandfather and the frequent visits they had to make to the hospital, his parents had little time to take care of him. Therefore, during this period, the parents left the baby in the care of Nachum and Sonya, a couple who were friends of the grandparents. The grandfather died when Chen was a year-and-a-half.

Today, Chen thinks that he has been a burden to his parents ever since he was a child: *"was not the most comfortable time the parents already had three more children. I was the fourth child and just a baby ..."*

Here, as in many other parts of the interview, Chen shares the perspective of his parents and shows no empathy for himself. Again and again in the course of the interview, he talks in great detail of his parents' heavy work load and mentions that they were and still are good kibbutzniks. In his opinion, they had little time for the children because developing the kibbutz was their main concern. As in the interview with his father, Chen talks only indirectly and between the lines about his own childhood problems. This is very similar to our experience when interviewing his father. Chen first emphasizes that he had a normal childhood on the kibbutz but then he mentions his problem with speaking: *"I hardly talked....kind of....I learned to speak because I spoke-I swallowed syllables"*. But this theme is unpleasant to him; he prefers to talk in detail about how he became active in the youth group of the kibbutz. Just like his father, he tries to find other people with whom he can establish close relationships. Since he was eight years old, he has regularly visited his grandmother Lea and her husband Jonathan. He says: *"I loved going to her terribly"* and then begins to accuse his mother, saying she always gave him too little money when he went on these visits. He says that he was ashamed to ask Lea for money. His statements concerning this theme make it clear that Chen has a conflict of loyalty between his mother and grandmother. On the one hand, he has a sense of obligation towards his mother; on the other hand, he can use the closeness to his grandmother to provoke his mother. Chen talks about his grandmother mainly in the context of her activities, giving lectures about the Holocaust. He hardly thematizes Lea's own experiences in Nazi Germany, her losses, and prefers to talk about the fact that Lea has made the Shoah her profession: *"She made it her occupation"*. Chen thus can hardly succeed in coming emotionally close to the feelings of his grandmother. He states in his interview that emotionally, he had felt closer to his paternal grandmother Malka. He complains, however, that Malka, unlike Lea, did not talk about the past: *"I feel the urge to investigate because, kind of I feel she hid, something. and I badly felt the need to know - I am the survivor"*. His declaration "I am the survivor" is indeed correct. For he is alive, unlike the murdered great-grandparents whose fate Malka had not divulged to him. Nevertheless, it sounds strange when the great-grandson of murdered great-grandparents calls himself a survivor. It reminds us of his mother's identification with her murdered grandparents, and of her childhood fantasies in which she imagined herself in a concentration camp. Chen, like his mother, thus considers himself member of a generation that immediately follows that of his murdered great-grandparents.

Chen is less interested in the maternal side of his family; this is Lea's responsibility, she is taking care of this. Instead, Chen has taken it upon himself to research the history of his paternal grandparents, which was hidden from him. When Chen was 13, during his Bar-Mitzva year, he wrote the family „roots paper“ on the Polish town from which his father's family had origi-



nated. At that time, he was unable to consult his grandmother Malka on the subject; she died when he was 16 years old. The following quote indicates how important she was to him as a source of information:

*"Growing up more and more grandma and I did talk, I also told her more about myself as if she was, as someone that I- which the parents were not, at the time, but I didn't need my parents because she existed kind of, that's why when she died kind of I missed so much someone that I could talk with."*

Chen tried to compensate for the loss of his grandmother by regularly visiting Sonya, his foster grandmother; who he still visits on a regular basis. He has her call him "my grandchild" in the family sculpture, and he argues that no other Caspi is so emotionally attached to her.

When he was seventeen years old, Chen took part in a trip to Poland by a group of youngsters who visited former concentration and death camps, as well as other places in the country which are of historic significance to the Jewish people. Ever since 1988, the Ministry of Education has organized these trips, expecting, among other things, that the young people taking part in them will return home aware that, today, the dynamic and strong nation of Israel will never again permit such suffering of helpless Jewish victims. Jacki Feldman, who analysed these tours, reached the conclusion that such a "voyage is one of the most intensive experiences that many students will have in the course of their education" (1995b. p. 338). Before the trip, Chen talked with his grandmother Lea. She gave him a map of her equivalent trip to Poland through "Lapid", an organization of first and second survivor generations. In addition, he interviewed a survivor from Greece. During the conversation, the survivor gave Chen the feeling that he would never be able to understand the experiences of those who had been persecuted. Chen felt that he could never experience emotions which would even come close to those of the survivors. This feeling was a heavy burden for Chen to bear during his trip to Poland. Together with 30 other youths, some teachers, and also survivors who accompanied them, they visited the death camps of Auschwitz, Treblinka, and Chelmo. It distresses Chen to this day that he could not show the feelings expected of him. The way he sees it, this happened because there were no survivors in his family:

*"I stood there in Auschwitz (3) in front of the shoes and it didn't prick me even. Because those pictures I know since I=was=a=little=child=I=know=those=pictures it is not new in Yad-Vashem we saw it in the preparation. Well then what do they expect me that I cry? I didn't cry because it isn't, because my grandmother hadn't been there nobody close had been there."*

Chen says, furthermore, that his great-grandfather, the father of Malka, perhaps had been in Auschwitz, but he had been unable to find his name there. Therefore nothing there could have touched him emotionally. It becomes clear that Chen tries to establish a connection between himself, the Shoah, and the family history. On that trip, he did sense such a connection, as well as an emotional closeness concerning the theme "life in the Jewish shtetl before to the Shoah". This closeness probably resulted from the stories his grandmother Malka had told him about her life in Poland before the war. In Treblinka, Chen was touched by the big memorial ground for the destroyed Jewish communities. There he searched for his paternal grandparents' home town. But, unfortunately, he was unable to find it. It bothers Chen that he does not know where his paternal great-grandparents were murdered and where they are buried: *"But I felt badly the need to know if she- in Chelmno or in Auschwitz or in Treblinka or in-where was it?"*

The context, in which this quote appears, leaves it unclear if Chen refers by 'she' to his great-grandmother. He is interested, first of all, in the locality where the annihilation took place. He continues: *"Or they shot them or-?"*

He is able to say "that they might have been shot", it is difficult for him to talk about other possibilities. He breaks off in mid-sentence after "or" and then continues: *"and then where are their graves, and that I would go there and- and- uh on grandma's behalf but grandma didn't, I don't know even on whose, on my behalf. I am the survivor."*

Chen is confused about who gave him the delegation to be the one who goes there, and he ends again with the astonishing remark: "I am the survivor". Like his mother Ofira, he puts himself into this position and is dealing with the problem in his family, who is the survivor. Chen has a problem connecting himself to the Shoah or to the family history. Chen feels that he cannot live up to what is expected of him. In describing his behaviour on the trip to Poland, he also says: *"I didn't like them play with my conscience, not in school and not at home and nowhere. Them making me feel that I wasn't all-right on that mission"*.

But who expects a certain manner of behaviour from Chen and what kind of behaviour? What is the mission Chen is speaking of? On the one hand, he feels no close personal involvement to the Shoah - in fact, others deny his capacity for empathy. On the other hand, he wishes to establish the closeness needed for empathy. Chen already had experienced this dilemma between feeling cut off emotionally and feeling emotionally close during a public lecture which his grandmother Lea gave on her memoirs. As he was sitting close to her, he felt cut off from what she had to say; but at the same time being physically close to his grandmother, sitting next to her helped him. He attempts to overcome his feeling of being cut off or separated by taking on the role of the survivor. But the question is whether this may not result in serious psychological problems.

## Concluding remarks

We assume that Chen lives and acts out a problem that is typical for his generation in general and particularly so for his family. In public settings and ceremonies intended to remind him of the Shoah, Chen is expected to show feelings that require a more intimate, let us say more authentic setting to express them in. Neither a trip to Poland nor his grandmother's public lectures help him to come close emotionally to the pain and sorrow connected with the murder of his great-grandparents. In this family, as in many others, grandparents and parents delegate to their grandchildren and children a task they themselves have been unable to carry out. Chen most likely feels this instinctively. His grandmother is making a "business" out of the persecution she suffered in the past - at least that is the way all the Caspi family members interpret what she does. How, then, could Chen feel close to these past events? His father was afraid to enter into a dialogue with the grandparents; he didn't dare to ask them how they had felt when they left their own families behind in Poland. Chen's mother nurses her own wounds; she is on guard against taking Lea's perspective of the persecution she had experienced in the past. His older brother Tomer refuses to live up to the expectations of the preceding generations. He neither accepts the delegation to remain on the kibbutz, nor is he interested in examining the family past. In contrast to the behaviour of other members of the family, Chen is the one in the family willing to approach the burdensome theme of his great-grandparents' murder. Thus, we can return again to the assumption we already formulated earlier, that the mourning process goes on from generation to generation - step by step. We refer to this as the intergenerational sequential process of mourning. The first generation grieves over and mourns the separation from their parents, the second concerns itself with the persecution of the grandparents, and in the case of the third, we can observe how they try to approach the theme of their murder. Chen searches for their graves and thus admits that the murder of his great-grandparents actually took place; he can accept it as a fact.

The interviews with Chen and others of his generation teach us the following: though their grandparents escaped persecution in time, the grandchildren feel very close to this persecution, in spite of the fact that it took place in the distant past. Exactly the reverse holds true of the common belief that the impact of persecution becomes weaker for later generations. The greater the distance from the time of the persecution, the less the specific knowledge that successive generations possess. And the less the specific knowledge they possess, the more powerful will be the effect of a diffused transmission that has come down through the generations.

No doubt, many of our descriptions generally apply to families living on a kibbutz. But in the Caspi and Arad family cases, something else becomes clear. The commitment to a life on the kibbutz and the relationship to the Zi-

onist ideals also depend on the family history. The latter is determined by the fact that the grandparents had to leave Germany or Poland in their youth and found a new community in the kibbutz. For these families, cooperation in building a new society coincided with the Shoah, the persecution and murder of their great-grandparents. On the one hand, this period evokes fond memories of a time when, full of hope, they were building a new country. On the other hand, this time period is connected with many guilt feelings.

The children and grandchildren of families, who made a commitment to the kibbutz movement, did, indeed, encounter great difficulties because of the commitment of their grandparents. But one must not underestimate the support these communities gave to the young immigrants in their efforts to adapt to the ways of the new country. The community of the kibbutz helped these young people, who had been forced to emigrate from Europe, as well as their children and grandchildren, to gain psychological stability. This makes it possible for them to gradually open up the family dialogue today, and talk about what happened before emigration, and about the murder of their families in Europe. This is made quite obvious by the willingness of the Arad, Weber, and Caspi families to be interviewed and to participate in family interviews, as well as by their openness when the themes of conflicts and family dissonances are addressed.

Part 4:  
East German Families of Forced  
Emigrants



### 13. Remembering in the light of anti-fascism in East Germany

Bettina Völter

#### Returning to Germany

Between 1933 and 1945, National Socialist tyranny forced thousands of Germans into emigration or into political exile. Only a fraction of them returned to Germany after the war.<sup>114</sup> In the early years after power was handed over to the Nazis, it was primarily political and intellectual opponents of the regime who fled the country. These 30,000 to 50,000 anti-fascists<sup>115</sup> left the country in the hope that the Nazi dictatorship would come to a swift end, allowing them to return from their temporary exile (Benz 1994, p. 9). Their situation was very different from that of the 250,000 refugees who between 1933 and 1941 were persecuted and driven out on the grounds that they were of Jewish descent. This emigration reached its height in the wake of the November pogroms of 1938. Jewish forced emigrants had to leave Germany under the most undignified of circumstances, "following discrimination and exclusion, robbed and derided, deeply humiliated and hurt. ... Many German-Jewish emigrants had survived concentration camps, had been maltreated and persecuted" (Ibid, p. 9ff). In nearly all cases, these experiences led to a decision never to return to Germany (Walter 1972, p. 204ff). In the post-war period, the tenor within international Jewish organizations was unanimous: Germany could no longer be a home to Jews. Jewish organizations in this country were seen as merely existing for the purpose of organizing the emigration of Jews (Burgauer 1993, p. 25).

The decision by some emigrants of Jewish descent to return all the same was one made for a variety of reasons (Ibid, p. 22; Verein Aktives Museum, p. 9). Many of those who returned only intended to do so temporarily to look for missing family members. For others, the motive behind their choice was their bond to German culture. Still others were tied to the German language professionally and could barely have eked out a living in a non-German-speaking country. But political motives, a desire to help rebuild democracy,

---

114 Cf., for instance, the documentation on those who returned to Berlin (Verein Aktives Museum 1995).

115 Benz (1994, p. 12) puts the figure at 30,000 to 40,000, while Grossmann (1969, p. 31) speaks of 50,000.

were also key factors behind the decision to live in Germany again. This was particularly true of returning emigrants who saw the future of a "better Germany" in the creation of a socialist-oriented society. Some of them, German Communists who had survived in the Soviet Union, were specifically sent back by Moscow to take over the party and state leadership in East Germany. But left-wing intellectual celebrities, who had gone into exile in Western countries, and many less well-known anti-fascists from West Germany, or from the Western countries to which they had emigrated, also decided to move to the Soviet-occupied zone or, as it was known after 1949, the German Democratic Republic (East Germany). Helmut Eschwege (1988, p. 65) speaks of some 3500 returning "emigrants from Western countries" of Jewish descent in the post-war period, who took their place "in all of the centres of economic, academic, cultural and political life".

For those of them who stayed, a key aspect of their bond to East Germany was its anti-fascist policies and the presence of anti-fascists in positions of power within the state. One of our interviewees expressed a feeling shared by many other returning emigrants:

*"There were also aspects of the East German regime that we totally agreed with, especially when you compared it to the West German state. For example, that over there the Nazis were actually allowed to take up their old jobs again, and bloodguilty judges got fat pensions, like Globke or Filbinger<sup>116</sup> to name a few, or others like them. ... That kind of thing was really impossible here, because a large number of the people who, well had a say up there in the Politburo, they'd been in concentration camps themselves or had emigrated, were of Jewish descent and so you somehow had a certain sense of security in that respect."*

Despite all the distance and, as a rule, suppressed criticism, too, that many of those, who had returned from emigration in Western countries, felt towards the East German regime, anti-fascism was one of the most important positive aspects that made the decision to return to this part of Germany seem the right one, even in retrospect.

When in some families, the children's generation began to call into question East Germany's anti-fascist culture of memory, they met with considerable resistance from their parents. As our research shows, these discussions led to heated intergenerational conflicts. This disillusioning and painful calling into question of anti-fascist ideals continued after the mid-eighties, particularly after the political changes of 1989, with anti-fascism - probably the last and most resilient basis of legitimation of the East German state - being

---

116 The interviewee is referring to lawyer Hans Globke, the commentator of the anti-Jewish Nuremberg Laws, who after the war was head of the German Chancellery under the first Federal Chancellor Konrad Adenauer, and to Hans Filbinger, a Nazi judge, who held the office of state premier of Baden-Württemberg in West Germany.



depicted as a "myth" (Grunenberg 1991) and as "state-prescribed anti-fascism" (Giordano 1990, pp. 215-228). One of the central criticisms was that while the East German leadership had declared the state - and by implication its population as well - the heirs to the anti-fascist Resistance movement, in the process it had de facto evaded coming to terms in any real sense with the National Socialist past and with its continuity.

Backed by and to some extent at the request of the Soviet occupying power, the leadership cadre within the German Socialist Unity Party (SED)<sup>117</sup> enforced a kind of anti-fascism from above as early as mid-1948. This primarily had the function of legitimizing the state and the regime (Meuschel 1992, p. 31). In the process, brutal means were used to thwart the realization of alternative perspectives and political approaches, primarily put forward by anti-fascists of Jewish descent.

#### Anti-fascism and the remembrance of the Shoah

Within the German Communist Party (KPD)/German Socialist Unity Party (SED), there were at least three distinct groups, each of which had a different standpoint on the question of what place remembering the Shoah should be allocated within an anti-fascist culture of memory (Groehler 1995, p. 9-14).

One of these groups was composed of individual emigrants, who had returned from Western countries, and Jewish survivors of concentration camps. It was because of their initiatives that the history of the persecution and suffering of the Jews at the hands of the Nazis was far more present as a theme in 1947/48 and was discussed far less dogmatically than in the decades that followed. Thus, Paul Merker, for instance, a member of the Politburo, who was himself non-Jewish, and a number of the Jewish Communists and Jewish community leaders, such as Julius Meyer or Leon Löwenkopf, considered the genocide the single most significant component of the Nazi system. They reflected on the complicity of the German population and called for very comprehensive political, moral and material "restitution" for the victims. They wanted to see Jewish community property and the private property of individual Jews returned to their rightful owners, and called for Jews in East Germany to be granted entitlement to national rights of minorities (Ibid, p. 12).

Representatives of political victims of Nazi persecution, who had survived in Germany in the underground, in prison or in a camp, were among those who rejected a perspective that focused on suffering, defencelessness and the victims. Although they did not hold key positions of power within the state, they nonetheless held powerful positions and exerted considerable po-

---

117 In the Soviet-occupied zone, April 1946 saw the compulsory merger of the German Communist Party (KPD) with the German Social Democratic Party (SPD) to form the German Socialist Unity Party (SED).

litical influence. The anti-fascist members of the Resistance stressed the *anti-socialist* component of the Nazi regime of terror and saw themselves as its archenemies who had emerged victoriously from the fight against the dictatorship. They wanted to see a distinction made between the "fighters" and the "victims" of the Nazi regime, and felt that, as fighters, they should be entitled to special recognition and a privileged status. They rejected the view that political and racial persecution should be placed on an equal footing. In 1965, they succeeded in enforcing this hierarchical classification of victims in the pension system as well. Thus, from 1965 on, victims of racial persecution received an honorary pension of 600 East German marks (in 1989: 1600 marks), while those, who were recognized as having fought against fascism, received 800 marks (in 1989: 1800 marks).

However, the group, that set the tone within the KPD/SED, was that of the emigrants who had returned from Moscow. The Soviet Military Administration backed them in the positions they held. As this group saw it, fascism had revealed itself to be the very form of rule that Georgi Dimitroff had characterized at the Communist International as early as 1933 and again at the 1935 VII World Congress as being: the "open terrorist dictatorship of the most reactionary, most chauvinist, most imperialist elements among the financial capitalists". According to Dimitroff's analysis, the quintessence of National Socialism was its anti-Communism. The fact, that victory over Germany was largely achieved thanks to the Red Army, was now seen as the best possible proof of the model character of socialism and the superior society it brought forth (Groehler 1992, p. 111). The prevailing opinion went on to assert that socialist society had banished the threat of a new rise of fascism and overcome phenomena typical of capitalist society such as racism or anti-Semitism.

Logically, this analysis of genocide and fascism emphasized the criminal war against the Soviet Union and the heroic resistance of the Soviet people and political opponents of the Nazi regime. In contrast, the genocide against the Jews was not seen as the principle crime committed by National Socialism, but rather as a further example of the criminal nature of German fascism.

### A policy of exclusion

In the immediate post-war period, the debate around "restitution" for the wrongs committed by the Germans was one of the first crystallization points at which the position taken by the elite in power began to take shape, and with it, their policy of excluding anti-fascists who held differing views.

Compensation to Jews in East Germany who had been persecuted by the Nazis, compensation that provided for the return of stolen Jewish property, at least in some cases, was predominantly advocated by representatives of victims of racial persecution within the KPD/SED and within the Association of

Victims of Nazi Persecution (VVN) and the Jewish community in the Soviet-occupied zone/East Germany. However, these demands clashed firstly with the interests of the Soviet Military Administration (SMAD), which had considerable vested interests in East Germany making reparations to the Soviet Union. They were also at loggerheads with the objective of the SED leadership of transforming the capitalist economic order into a socialist economy. With reference to the historical necessity of the class struggle, many were not averse to helping themselves to social prejudices and anti-Jewish clichés. Thus, for instance, Walter Ulbricht, himself an emigrant, who had returned from Moscow, and later East Germany's head of government and party leader, rejected the proposed return of stolen Jewish property with the words: *"Now, we were always against the Jewish capitalists just as we were against the non-Jewish ones. And if Hitler hadn't expropriated them, we would have done it after we came to power."* (translation of Ulbricht as quoted in Goschler 1993, p. 102).

In the end, a decision was made in favour of a "restitution" based on the "welfare principle". This comprised the integration of recognized victims of Nazi persecution into the social security system, including health care and pensions. This arrangement was limited to those victims of persecution who lived on Soviet-occupied zone/East German territory and had suffered in concentration camps or been exposed to other forms of persecution as "star-wearers". Those who had been in "mixed marriages" that the Nazis had designated "privileged", or who had been persecuted as *"Mischlinge"* (persons whom the Nazis defined as the "mixed offspring of Germans and Jews"), were not considered victims (Groehler 1994, p. 284).

The decision in favour of the "welfare principle" was a decision against a settlement oriented on the principle of compensation, such as the one that West Germany finally opted for in 1953. While this arrangement focused on material "restitution", questions of property were not settled in East Germany.<sup>118</sup> And only a fragment of the property, that had been expropriated from Jewish Community Centres during the Nazi period, was returned to them - in contrast to the parishes. The East German regime declared the majority of it state-owned property in 1952. Seen against this background, even what occasionally seemed like generous financial allocations from the state to the Jewish Community Centres appear no more than pittance, and this funding always demanded corresponding good behaviour (Goschler 1993, p. 97ff). And finally, all East German governments refused to make restitution payments to Israel, arguing that their state bore no responsibility for the crimes committed by the "Third Reich". The political background was dominated by the Cold War and the policy of alliance between Israel and the US

---

118 A temporary exception to this rule was the restitution law in Thuringia (Schüler 1993, p. 118-138).

from 1948 onwards, which led to the Soviet Union's initially pro-Zionist stance turning into one of anti-Zionism.

The show trials held in the Soviet Union and in a number of Eastern European countries starting from the late forties on can also be seen in this context. Their victims were distinguished Jewish Communists who faced trumped-up charges. They were accused of maintaining links to the Zionist movement and to the US intelligence service. In late 1949, stage-managed by the Soviet occupying powers, preparations were made for show trials in East Germany, too (Diehl 1993). A special commission was given the order to vet all party members, who had returned from emigration in Western countries, regarding their past and their contacts to the West. People who had returned from emigration in Western countries, especially Jews, were dismissed from leading positions and important functions in the state apparatus as early as 1950. The purpose of these measures was primarily to discipline the other comrades along Stalinist lines and to cement the dominant position in the party and its organizations of the emigrants from Moscow. In a series of trials, people who had returned from emigration in the West were cross-examined, particularly about their contacts to a certain US citizen, Noel Field. Leader of the Unitarian Service Committee, one of the organizations that had helped people to emigrate from Germany during World War II, Field was slandered in the Rajk trial in Budapest and in the Slansky trial of 1952 as an "imperialist agent" and his supposed collaborators were defamed as "cosmopolitans" and supporters "of Zionist monopoly capitalists". Most of those who were condemned were Jewish. Anti-Semitic persecution in East Germany reached its peak in December/January 1952/1953 in the wake of the sentence passed at the Slansky trial, which reeked of anti-Semitism. The offices of the Jewish Community Centres and Jewish homes were searched for evidence of suspected "Western contacts", Jewish community representatives were interrogated and pressed to give the authorities information about their members' Western contacts and to sign anti-Zionist declarations. Paul Merker, who was slated as one of the principle accused in the planned trial, was taken into pre-trial detention. He was accused of having called for the "sacrifice of German state-owned property" in the "restitution" debate, and of having pushed the "interests of the Zionist monopoly capitalists" "to pave the way for US financial capitalists to penetrate Germany" (Documents-SED, 1954, p.199ff). Merker remained in custody until 1956 and was rehabilitated after his release.

Alarmed by the rising number of interrogations and arrests in late 1952, some 450 Jews fled East Germany by late 1953 alone, including the most politically active members of the Jewish community and representatives of victims of racial persecution within the Association of Victims of Nazi Persecution. This meant that the representatives, who had publically advocated "restitution", were out of the way, leaving the field open for the state to disband the Association of Victims of Nazi Persecution, whose members were

predominantly Jews, and replace it with the "Committee of Anti-fascist Resistance Fighters".<sup>119</sup> The Jewish community had lost all significance as a political factor. When a sudden change of course was embarked on in 1953 towards a policy of supporting Jews in East Germany, the Jewish Community Centres had hardly any members left (Richarz 1986, p. 15-17)<sup>120</sup>.

#### Interviews of families of those who returned from emigration in Western countries

The families of emigrants who returned from the West, whom we interviewed, were made up of family members of Jewish and non-Jewish descent. In their family pasts, we find emigration, racial and political persecution as well as the life histories of family members who were among the collaborators and perpetrators of the Nazi regime. None of the interviewees of Jewish descent belonged to a Jewish Community Centre at the time of the interview. Most never had, others had not rejoined after the war or had cancelled their membership in the fifties. The grandparents' and parents' generation in particular identified as Communists at least during the East German regime and were members of the SED. Certain members of some of these families had agreed to work as informants for the East German secret service, the *Stasi*, in the belief that this was a way that they could support the state.

In our analysis of these interviews, one of the things we were interested in discovering was which memories dominate in the family memory over the successive generations. It emerged that in their presentations, members of all three generations focused on the anti-fascist aspect of their family past. Much like in families of those, who were forced to emigrate to Israel as young people (Chapter 3), in families where both grandparents were able to emigrate, a great deal is said about the history of their emigration. In contrast, the history of the suffering other family members endured during the persecution in Germany and the murder of Jewish family members are only mentioned in passing. The second and third generations are only able to give a fragmentary description of these parts of their family history. Some members of the second generation only found out about their Jewish background through philo- or anti-Semitic remarks from people outside of the family. The history of the non-Jewish family members, who were among the collaborators and perpetrators of the Nazi regime, was barely passed on at all. This part of the family background was generally only hinted at in the interviews. The non-Jewish

---

119 The disbanding of the Association of Victims of Nazi Persecution must be seen in a more complex context. It was also directed at what was seen as the excessively dominant position of those members of the Resistance, who had survived in the underground or in prison (as opposed to emigrating to Moscow), and against an underestimation of the role of the Soviet Union in liberating Germany (Groehler 1995, p. 21f).

120 For more on further developments, cf. Chapter 1.3.

grandparents themselves emphasize their own suffering during the war and in the post-war period. The generation of their children and even more so that of their grandchildren know almost nothing of the facts relating to the history of these grandparents.

We conducted our interviews at a time of widespread public debate about the Shoah, anti-fascism in East Germany and Jewish life in Germany. Some of the grandparents of Jewish descent whom we interviewed had already begun to confront their biographies in the eighties. A number of them committed the history of their families and their lives to paper, and others visited Jewish relatives in Western countries. This altered attitude towards their own life history and family biography led to a rethinking of the persecution they experienced during the Shoah. Many families started researching into the fates of their murdered family members in the immediate post-war period, but then broke off their inquiries for over four decades. In nearly all families, these efforts were resumed in the eighties and after the Wall came down in 1989.

While the generation of the grandparents increasingly began to reexamine their history before and during the Shoah, some members of the children's generation began to look at anti-fascism in East Germany in a critical light. They reflected on taboos, that they had experienced themselves in their family history, and of taboos in society, such as anti-Semitism in East Germany. This led to critical disputes with their parents, whom they accused of having gone along with the East German regime or of having justified its policies. Other members of the children's generation have strong bonds to their parents. This generational unit accepts the taboos in the family and continues to feel committed to the East German regime, even though it has ceased to exist, especially because of its anti-fascist ideals. In the grandchildren's generation, in both types of families we find a strong preoccupation with experiences after the political changes of 1989. While grandchildren in families, where political disputes arise, tend to distance themselves from their family history, grandchildren in bound families tend to have difficulties presenting a family history and an individual life history.

However, the tangible confrontation of the grandparents' and children's generations with the history of the Shoah has so far had little impact on the structural depths of the family and life stories. It is true that the first and second generations felt a need to reflect on their Jewish background or on the discourse around the Shoah within their family and in society, but the stories of all three generations continue to focus on the anti-fascist Resistance.

A comparison of the Basler family and the Kaufmann/Liebig family, both of whom are presented below, reveals both different experiences in their backgrounds and differing family dynamics. While the Basler family represents a more-or-less bound family, the Kaufmann/Liebig family evinces ten-

dencies of a split and disintegrating family.<sup>121</sup> The Basler family exhibits the marks of close intergenerational and intragenerational ties. The family members emphasize this closeness and permit themselves little distance from one another. The myth of a common history helps this family unite the differing parts of the family history into a single, harmonious version. This allows them to avoid seeing family members, who were collaborators and active Nazis, as potential persecutors of family members who were victims of "racial" or political persecution. The political changes in East Germany and the public reinterpretation of the Nazi past, that followed in the wake of the demise of the East German regime, if anything strengthened this family's defence mechanisms, rather than leading to more open family dialogue and to the themes of family secrets and taboos being addressed. This may also have to do with the fact that certain family members worked as informants for the *Stasi* and wished to keep these activities secret after the political changes of 1989.

In contrast to the Basler family, in the Kaufmann/Liebig family we find tendencies of a split and disintegrating family. The "break between the generations" is a theme that concerns all three generations here, particularly the distance between the grandparents' and the parents' generation. Among other functions, this conflict serves to exclude from the family dialogue parts of the family history that are biographically loaded or under taboo. However, unlike the Basler family, the grandparents' differing worlds of experience are not fused into a harmonizing version of the family history, but rather are the subject of political dispute. In the Kaufmann/Liebig family, the political changes in East Germany led, if anything, to an opening of the family dialogue between the generations.

---

121 For more on the concept of bound, split and disintegrating families, cf. Wirsching/Stierlin 1982, p. 123-150.





## 14. Anti-fascism as substitute mourning: The Basler family

Gabriele Rosenthal and Bettina Völter

The Baslers are typical of a family of Jewish origin in former East Germany, both with regard to the trajectory of their family history and their way of dealing with the history of persecution. We conducted five interviews with them: with the grandmother Gertrud Basler, her son Gerhard, his non-Jewish wife Silvia and with the grandsons Ralf and Roland. Both Gertrud and her son Gerhard refused to participate in a family interview. Let us now look at the life story of each member individually.

### The first generation

Gertrud, the grandmother, was born in 1919 near Heidelberg. Her family lived strictly according to Jewish rules. Her father was a tailor and her mother owned a textiles shop. Gertrud had seven siblings. In 1933, at the age of fourteen, she began to work as a maid in several Jewish households. One by one these families began to emigrate out of Germany. By 1939, four of her older siblings had also emigrated to Australia with the help of her father's relatives. In May 1939 Gertrud herself emigrated to Sweden on her own steam. In her interview, she goes no further than to hint at feelings of rivalry towards her older siblings. Shortly after her arrival in Sweden, she was initiated into the KPD by her new circle of friends. There she met her future husband, Manfred, who was non-Jewish and who had fled Germany as well. When the Nazis came to power in 1933, Manfred and his brother Paul, a well-known philosopher, were active in the resistance against National Socialism as communists. While Manfred managed to escape to Sweden, his brother was captured by the Nazis and died in a Gestapo prison.

Gertrud and Manfred married in 1940 and in 1944, their son was born. In 1946, the Baslers returned to Germany and lived in West Germany, until 1949, when they went over to East Germany. Not too many years later Gertrud and her husband separated. Since her return to Germany, Gertrud has repeatedly tried to look for information on her family that stayed behind. In 1947, she received archival information that her younger sister was transported to an extermination camp and died there. One of her brothers was murdered along with his family. She also found out that her paternal grandparents had been killed in Holland. Some years after the war, she was able to determine that her parents had been taken to the concentration camp in Theresienstadt. It was only after 1989 that Gertrud inquired at the archive at the

Theresienstadt memorial and found out that her mother and father were transported from Theresienstadt to different camps at different points in time. In spite of this knowledge, she tries to alleviate her grief at the loss of her parents by imagining that they died together in the gas chambers. She insists that her mother, eleven years younger than her father, voluntarily accompanied him to his death: *"It was typical of my mother to say that she wouldn't let my father go alone. I'm convinced that this is how it happened. And she must definitely have fought so they could go together."* Gertrud finds it easier to live with this fantasy than with the possibility that her father might have died alone. The thought that her mother fought against the passivity of her situation is equally soothing. Alone with her grief and her thoughts, she hardly ever has the opportunity to talk about her parents' deaths or to share her pain with others. *"Not a day goes by when I don't think about these things. I was the only one who went away to Sweden. I always lived without my family"*. How little of this is talked about within the family becomes clear, especially in the interviews with her grandsons. Just how threatening these memories of her family can be for Gertrud also becomes clear from the textual structure of her biographical self-presentation. Despite repeated attempts on the part of the interviewer to motivate her into talking about her family, her childhood and upbringing, she only answers with descriptions of everyday routine in a religious household, refusing to relate any stories about her parents or her siblings. Although she begins her interview by recounting relevant dates in her family prior to her emigration, her presentation focuses to a much greater extent on her own experiences of persecution after she left home at the age of fourteen. Rather than speak about her family, she concentrates her narrative from 1933 to 1939, i.e. up to the point of her departure, mainly on her life outside the family. We interpret this text structure as being influenced by her guilt at having survived. Like many of her generation, Gertrud was in a situation of despair. Her parents and younger sister had written to her for help, even for money, so they could pay for visas in order to emigrate, but she was in no position to help. Especially in the months before the war broke out, her days were entirely taken up with the *"problem of how to get the parents out of there."* The last set of letters Gertrud exchanged with her parents and her sister, providing further insight into this inner-family conflict, was in 1941. After a long silence, she writes to tell them about her marriage. Her parents and sister write back, complaining about her long silence, adding that they regretted that she had married a non-Jew. The mother writes: *"However, since it is already the case, then let it be so. As a mother, I wish you and your husband every happiness and send my blessings. I pray to God that your marriage may be a happy one."* Gertrud did not reply to this letter. Nor did she exchange any more letters with her siblings in Australia. Her political ideas and her related lifestyle, as well as her marriage to a non-Jewish academic, drew her further and further away from her background. She had moved away not

only from her family but also from her life as a Jew and had found instead a new home for herself in an atheist, communist world. Her marriage and her new circle of like-minded people were definitely a great help during her adjustment to a foreign country. When she moved to East Germany, she was asked by the communist party to make a clear decision as to whether she identified as a practicing Jew or not. The party line did not allow simultaneous membership of the Jewish congregation and of East Germany's ruling party, the SED. In the early fifties, Gertrud therefore renounced her Jewish identity. We surmise that this is a further reason for her guilt feelings, especially after the Wall came down in 1989.

Her efforts to construct a memorial, together with her family, to her non-Jewish brother-in-law, Paul Basler, in his hometown, provide further insight into her difficulties in dealing with her family history. Every year, the family conducts a memorial service there. As the interviews with Gertrud's son and her grandsons also show, this non-Jewish member of the resistance, whom she personally knew, is the only victim of National Socialism who is openly commemorated by the entire family. In psychoanalytic terms, this could be a displacement of the grief at the killings of her Jewish family members onto a process of grieving for a political member of the resistance from the non-Jewish side of the family. In this context, it is possible to use the term "substitute mourning". This displacement is also influenced by the social discourse in former East Germany, where members of the communist resistance earned far greater respect and acceptance in public memory than did religious Jews. Biographical case reconstruction shows that Gertrud Basler replaced her Jewish self-conception with her communist identity. While this exacerbates her guilt feelings towards her family of origin, at the same time, it helps her to block these feelings and provides her with a way of occupying herself with the politicized, non-Jewish side of her family. However, in contrast to other Jewish families we interviewed, Gertrud feels deeply connected to the time in her life she spent growing up in a Jewish milieu. As opposed to many other Jewish communists, she was still a member of the Jewish congregation during the initial years in East Germany. She says: *"Everyone who knows me, knows that I'm Jewish. It has always been that way."* However, she still sees herself as a communist and continues to be a member of the PDS, the party that came out of the former SED. If she were to question this identification, her distance from her parental family would become an even greater problem for her.

### The second generation

Gerhard Basler, born in 1944, is the only son of Gertrud and Manfred Basler. He works as a historian and was an active member of the SED.

Asked to narrate his family history and his life story, he begins with his biographical self-presentation: *"I was born in Sweden, on (...), in 1944, as the*

*son of an emigrant family*". After this introductory statement, which we may read as an identity tag, Gerhard Basler narrates his family history under the rubric "emigration". His life is specifically defined by the fact that his parents could escape persecution and that, after he was born, the family moved from a Western European country to East Germany. In concrete terms, however, he knows little about his family history prior to 1945. Although he can talk at length about the later part of his life story, when it comes to the topic "family history", he suffers from a total block, able only to hint at certain things, and often breaks off his report or lapses into silence. While to his relief he can recount a few "*facts*" about his maternal family, his knowledge about his paternal family is totally fragmentary. But from his implications and the gaps in his knowledge, we may surmise that there were some Nazis in this branch of the family. At least one of his father's brothers was a member of the Nazi party and therefore a potential threat to Manfred and his communist brother Paul. However, this aspect of their past was never discussed openly in the Basler family. This tendency to remain silent about, or even make a secret of, the unpleasant parts of family history comes up in other contexts as well. For instance, only after many pointed questions did Gerhard admit that his father died while under psychiatric treatment, in Gerhard's words "*surrounded in mental darkness*".

In his interview, Gerhard Basler, moreover, displays a noticeable need for harmony with regard to the relationships in his family. For example, he refuses to distinguish between people whom he feels close to and those he does not. He can only partly meet the request of the interviewer to illustrate this with the help of a family sculpture illustrating his emotional relationship with different members of his family. After he has stuck the circles representing his wife, his sons, his mother and her partner on top of each other, to signify that he is equally close to each of them, he refuses to position his uncles and aunts. He likens the request to demonstrate emotional closeness and distance through graphic representation with Nazi practice, which divided people into categories which read: "fit or unfit to live". He says:

*"I refuse to put human beings into hierarchies. I cannot do it. Even apart from the Holocaust, when one has two children one compares them and asks of oneself, which of the two do you love more. This question cannot be answered and I refuse to evaluate in this way. I don't consider it human."*

In the conversations that followed, regarding his vehemence on the matter, it became clear how strongly he fears the question of which of his sons he feels closer to, a question he often finds himself asking. He feels a tremendous pressure that it is wrong to differentiate within the realm of his family. In this context, Gerhard Basler begins to talk about his mother having survived the persecution, as opposed to her sister and her brother. When asked whether he thinks that his mother has guilt feelings, he responds strongly: "*I think it's*

*possible. But I would never discuss it with my mother. It's too personal, I wouldn't want to trespass. I would only hurt her with a question like that and I don't want to dig around in the past in that way."*

Like numerous members of the second generation of emigrants who returned to East Germany, Gerhard Basler had identified with socialism for as long as he could remember and had worked to fulfil its goals. After the Wall came down in 1989, bringing with it a crisis in his work life as well, he began to question his own behaviour during former East German times. The revival of Nazism, racism and anti-Semitism in Germany deepened his insecurity and lent greater importance for him to his Jewish origins. While earlier he would have identified more strongly with the communist tradition within his family and definitely knows more about it even today, his connection to his Jewish family history has grown in importance in the newly-unified Germany. What remains important for him, however, is the difference between the family history of his father, who was part of the communist resistance, and that of his mother, whose family members, according to him, "went to their death without resisting." Gerhard would like, above all, to resolve this difference. This becomes clear not just through his actions -- he too displaces his grief onto the non-Jewish resistance fighter Paul -- but also in his dreams. When asked what kinds of dreams he had as a child about his grandparents' fate, he describes persistent dreams in which he saw himself on the way to the gas chamber: "*Pretty realistic dreams, where someone says 'Let's see if you all are brave enough and if you can march in there', and I knew what it meant."*

Gerhard interprets this situation of ultimate powerlessness, i.e. the journey to the gas chamber, as a courageous act in his dreams, thereby dissolving the differences in the family histories of his father and his mother, fusing them into one shared image. Moreover, in this way he continues with his mother's fantasy in which she imagines her own mother fighting to be allowed to accompany her husband to the gas chamber.

In 1973, Gerhard married Silvia Scholz, a daughter of non-Jewish parents. Silvia was born in 1949. She too is a trained historian and was an active member of the SED. Silvia's grandfather worked for the Reichsbahn (the German railway) and was transferred in an important capacity to Posen, in the annexed part of Poland, when the war started. The Reichsbahn administration in Posen was responsible for loading Jews onto trains from Wartheland for transportation to the extermination camps (Hilberg 1990) and it seems highly probable that he was involved in the process.

Silvia never got to know this grandfather. In her family, he is considered missing, presumed dead as of 1945. Her statements about her grandfather's potential involvement in Nazi persecution are fairly unreflected and she blocks out the emotional underpinnings entirely. When asked by the interviewer, whether her grandfather had anything to do with the transportation of Jews, she answers succinctly: "*I think that in Posen he (the grandfather) did,*

*because it was a railway junction, and trains to Auschwitz and Treblinka had to pass through it."*

Silvia herself was born out of wedlock. Her father was a commanding officer in the Red Army and was stationed in the Soviet-occupied zone. He lived together with her mother and her, until she was a year old, and then returned to the Soviet Union. Since then, she has lost all contact with him and he is never mentioned in the family: *"that was always something that strained relations between my mother and me, because we never really talked about it"*. In 1954, her mother married again. Although Silvia always knew she had a different father, her mother kept his identity from her until she was eighteen. The secrecy around his real identity was sometimes the topic of gossip outside the family. When she was a child, Silvia was once told by a friend: *"My mother said your father is a Russian'. I said: 'No, that can't be, that's not true.' And I said it with total confidence"*. Today, she herself makes a secret of her father's existence within the family. In her interview, she emphasizes that her sons should not learn about him. For them, her stepfather is her actual father. The decision to keep the existence of their real grandfather from them has far-reaching consequences for the family. Ivan Boszormeny-Nagy (1975, p. 296) writes in a similar context: "One such decision makes every subsequent effort at honesty and openness among family members concerning important matters in life impossible." Silvia's husband is also forced into the role of the accomplice. The grandfather becomes part of internal family secrets (Karpel 1980) with which the parents keep parts of the family history from the children. Silvia therefore puts her children in a situation similar to the one she was in as a child, and one day they too could be confronted with statements such as, "your grandfather is a Russian."

The thematic field, that Silvia's life story is embedded in, is her political trajectory as a socialist. Silvia and her husband's common political orientation help them ignore unpleasant parts of their respective family histories. Her marriage to a Jew, who identifies himself as a communist first and foremost, enables her to distance herself from the Nazi elements in her family background and at the same time to identify with the victims, without having to deal with her grandfather's involvement in their persecution. Their common political ideas also take care of any potential conflict within the family which could otherwise result from the difference in their sensibilities and perspectives owing to different family histories.

### The third generation

The grandsons Ralf and Roland were born in 1975 and 1978, respectively, and are still in school. Their presentation of their family history also begins with the topic of "grandmother's emigration" and they know nothing of their family history prior to this point. The younger brother Roland, when asked to

recount his life story as well as his family history, begins: *"Well, I know that my grandmother (3 second pause) went over to Sweden with her entire family during the Nazi era."*

It is clear from the first sentence that Roland has never found out or felt the need to repress the threatening parts of his family history, for instance that his great great-grandparents, his great-grandparents and his grandmother's siblings were killed, and that the grandmother was alone in Sweden. He continues: *"....and there she (2) gave birth to my father (5 second pause, takes a deep breath) and then her brother and other relatives remained in Sweden or moved to Australia."*

At this point, Roland introduces his great-uncle Paul Basler, the communist resistance fighter, into the narrative, along with the information that he died of an illness in a concentration camp. Then he goes on to speak about himself: *"....well, that I have Jewish roots (2) and I don't really know in which, phf, well, I think my father's family is Jewish and my mother's is not. My mother comes from M. and (2) um..(3) well, I don't know anything about that (5)..."*

Roland is not sure who was or is Jewish in his family. His confusion about who is related to whom, in which way, is so great that he thinks Paul Basler is his grandmother's brother and therefore a Jew. The numerous pauses in his recounting of his mother's family point to his own confusion and above all the darkness her family history is cloaked in. However, at the very least, Roland has some vague feeling that there were Nazis in this branch of his family:

Roland: "Grandmother also said they had all cheered Hitler at the time, he gave them work..., obviously, it was a dictatorship, and anyone who didn't go along with it was done away with, and so they preferred to go along with it...more than anything he (Hitler) enticed them, everyone could get a job and the Jew is to blame and once the Jews have been removed, your situation will improve."

Interviewer: "Can you imagine that your grandmother also thought this way?"

Roland: "Well, I would rather not imagine that....I don't know."

As a result of his family tradition and his socialist education, Roland identifies strongly with the communist resistance. Faced with the question of what meaning he attributes to whether someone was persecuted as a Jew or as a communist, his initial response is based on a scene from the television series "Holocaust" in which *"...thousands of Jewish families were transported away and there were only about 20 guards. And the Russians made a run for it because they recognized they were numerically stronger and the Jews didn't try to defend themselves."*

In his conception, Jews, as opposed to communists, are passive. Since, however, he makes his great-uncle Paul Basler out to be a Jew, this causes great confusion. When asked *"And on which side do you see your uncle?"*, he answers:

- Roland: "If he was in the resistance he must have been a communist but he was (3) a Jew (15).  
Interviewer: "Are these mutually exclusive?"  
Roland: "(3) Well, I can't say now how I place him, as a Jew or as a communist (15).  
Interviewer: "What would you rather see him as?"  
Roland: "As a communist (4) but (16) I don't know (6).  
Interviewer: "What's going through your head at this moment?"  
Roland: "I don't mean that I'm ashamed that he was a Jew (3) that was stupid of me (5) I'm a Jew myself."  
Interviewer: "Have you ever thought about how you would have behaved?"  
Roland: "As a communist or uh, or how. If I wasn't alone, I would put up a fight, if one does that alone and not in a group it makes little sense. One always has to be part of a larger mass (7)  
Interviewer: "How do you imagine Paul Basler in the camp, alone or in a group?"  
Roland: "Well, as an outsider, because those in the camps were mostly either Jews or communists and he was both."

For Roland, Jews and communists do not belong in the same scheme; Jews, who are communists at the same time, do not belong to any group for him. This crucial statement in the interview corresponds equally to how Roland feels about his life after German unification. As the son of communist parents, he falls under the most attacked minority in Germany today. As a "leftist" and a Jew he fears the neo-Nazis and right-wing extremists who are now active in his school. However, he tells the interviewer that he is friends even with them. They are "sportsmen", and therefore unpolitical and not so radical. Obviously, he fears the role of the outsider and the thought of having no one to stand by him. As a result, he harmonizes his relationship with his potential persecutors, despite having been attacked by neo-Nazis in the subway once. By arranging the past and the present of both persecuted and persecutor into a harmonious picture, Roland tries to do away with the threat such a reality would otherwise present. This shows how behaviour patterns, present in the earlier generations of his family related to the refusal to disturb or confront certain family links to National Socialism, are handed down to later generations.

This confusion around the process of mourning and the handing down of



family history produces a sense of diffusion in the members of the third generation that defines their entire identity. Even if one interprets this in the case of the fifteen-year-old Roland as a lack of orientation during mid-adolescence, in the case of his eighteen-year-old brother Ralf it becomes increasingly clear that this confusion equally results from their specific family dynamics. In Ralf's case, both his confusion regarding his relatives and the lack of a concrete sense of identity that results from this are more pronounced. Although at the time of the interview he was eighteen years old, he could barely narrate either his family history or his own life story. His markedly brief response when asked to recount the above can be broken down into four headings: emigration, lack of knowledge about when his paternal grandfather actually died, Jewishness in the family, and great-uncle Paul:

*"Well, I know nothing of what happened before World War II, I only know that they escaped to Sweden, America, Australia, and got to know many of their present friends at the time. My father's father died there. I don't know if that was in the war or before. ... Well, they are very interested and involved in Jewish culture, museums and so forth, and they built a memorial or some such thing to my uncle, he was some kind of a philosopher and, well, (6) I guess that's it for starters."*

In his fantasies, Ralf has his grandfather die before his return to Germany. This is probably because no one in the family ever mentions that the grandfather died while receiving psychiatric treatment. Ralf's interview also illustrates that he substitutes addressing the theme of his Jewish family members with addressing that of his non-Jewish great-uncle Paul. When asked what he had been told by his grandmother about her past, he replied: *"Well, actually we only spoke about the philosopher all the time, not much about the rest of the family."* Ralf's confusion around his family history is especially striking with regard to his mother's family: *"I don't know whether they (the grandparents) were Jews or not."* He also wonders if they emigrated out of Germany under National Socialism. However, he clearly considers his mother Jewish: *"As far as I know she's Jewish, she's very into Jewish culture."* In his understanding, Jewishness is obviously defined by Jewish culture. He defines himself as a Jew but also fears being identified as one and tries to keep his Jewish family background as inconspicuous as possible in his school. He is especially fearful of the neo-Nazis in his class, *"although we get along very well."*

Asked to narrate his own life story, he says:

*"Hm, well, hm, so I was born at some point, and what really impressed me, well (3) hm (2) difficult to say (2) because the last thing I know is the radical change, the turning point here in East Germany, that's really impressive....the last two years now, also left their mark on me, because neo-Nazism and hatred of foreigners and suchlike keep growing in Germany (2)*

*that's also a little confusing (5) hm (6)..."*

For Ralf, as also for his younger brother Roland, the fall of the Wall brought about a sense of insecurity in their self-understanding, a simultaneous strengthening of the awareness of their Jewish origins and a growing fear of the neo-Nazis.

### Concluding remarks

The Baslers represent the type of family where the focus on the emigration within the family story allows a denial and warding off of the unpleasant and threatening parts of their family history. This repair strategy helps achieve two things: firstly, splitting off their grief at the loss of the murdered Jewish members of the family and secondly, blocking out of the family history what the non-Jewish members did from 1933 to 1945. In other Jewish families, where the grandparents were also forced to leave Germany, we observed the same repair strategy. Both in families in East Germany and in Israel, the family histories and life stories are narrated under the latent heading "Shoah" and the manifest ones of "emigration" and "living in the new society". In the families from former East Germany, the theme of "emigration" could and still can be embedded in the socialist self-conception of all three generations. This is because for the grandparents, the "anti-fascist" trajectory began or was again able to continue with this emigration.

What is specific to East Germany in the Basler family is that they commemorate the victims of National Socialism in a peculiarly indirect way, through strategies of mourning supposedly directed at a non-Jewish resistance fighter. This corresponds to its public variant in former East Germany, which was reduced to exclusively mourning the murdered communists. Anti-fascism therefore fulfils the function of substitute mourning in such families.

As in many other Jewish families, with the Baslers, the fact that some family members were implicated in the Nazi system remains undisclosed. Instead, the family's common identification with communism is emphasized and in this way, the divergent family pasts are harmonized. The specific family dynamics that arise from such harmonization correspond to the larger social dynamics in East Germany. In this context, it is necessary to note that, in order to present itself as the new, anti-fascist Germany, the East German state rejected all continuity or connection with the Nazi past. After 1945, only the things that bound everyone together were stressed, i.e., the building of a socialist society, so that the theme of the differences in family histories resulting from different backgrounds could not be addressed. Even when both persecuted and persecutor could be found in one's family history, this social reality strengthened, indeed demanded, the individual need for harmony and denial. This mechanism, institutionalized over years, was seriously called into question after the Wall came down in 1989. However, although this crisis widely

affects such family histories, it may not be wrong to assume that as an initial reaction it will be accompanied by even stronger defence mechanisms rather than an immediate opening up of family dialogue.

For the Baslers, the denial of divergent family pasts gave rise to family secrets and the myth of the communist resistance fighter. These can only be revised with the help of far-reaching biographical processes of reinterpretation in the future. In the case of the grandsons, the existence of these secrets and myths has led to extreme confusion regarding both their own life stories and the general family history. This insecurity was heightened by the fall of the Wall, bringing with it as it did the possibility of new forms of self-definition and religious identification for former East German citizens in general (Völter 1994). This transformation is not just a possibility today, but a demand they are socially required to meet. Social transformations require the reorientation of biographies and so hitherto unquestioned family and individual pasts have to be looked at anew. This process of looking into the past may bring up more difficulties than many individuals are equipped to deal with, and this, in turn, may lead to them again blocking out or making excuses for certain parts of their past.



## 15. An anti-fascist "legend"? The Kaufmann Family

Bettina Völter

### *Preliminary Remarks*

The grandparents on both sides of the Kaufmann/Liebig family were among those Germans who resettled in the German Democratic Republic (East Germany) from the Federal Republic of Germany (West Germany) after the war. They share a commitment to rebuilding Germany along socialist lines, however, there are clear differences in their paths through life and in their political stance during the period of National Socialism. Whereas Hilde and Martin Kaufmann were among those "racially" and politically persecuted by the Nazi regime, Herbert and Elisabeth Liebig were more on the collaborators' side during this period.

The marriage of their children Dorothee and Michael made these different worlds of experience the subject of family dialogue. And unlike in the Basler family discussed above, later generations do not merge these worlds into a harmonizing family history. Indeed, each of the four grandparents' individual biography is the object of sceptical examination by their children and grandchildren. In both the Kaufmann family and the Liebig family, heated political conflicts between the generation of the grandparents and the generation of their children are one of the key structural criteria of the family system. While the daughter Dorothee, for instance, accuses her father Martin Kaufmann of making the history of their resettlement in East Germany a taboo, instead telling his life story as an anti-fascist "legend", her husband Michael considers his father Herbert Liebig to be a "Nazi" who became a "Stalinist" and he refused to have any contact with him for years. With the help of each other's perspective, both partners try to loosen their ties to their family of origin. The generation of the grandchildren has grown up at an emotional distance from the generation of the grandparents and has developed an image of their family that is split into seemingly disconnected elements.

*The Kaufmann grandparents: Persecution as "non-Aryans" and the history of the Resistance*

The grandparents Martin and Hilde Kaufmann, both born in 1924, come from "mixed" families: their mothers were daughters of Christian parents, and their fathers were of Jewish descent. However, their fathers considered themselves no longer linked to religion and tradition and were not members of the community<sup>122</sup>. Thus, under Jewish law, Hilde and Martin Kaufmann were neither Jews, nor raised Jewish. Nonetheless, the Nazi's "race" ideology and laws applied to them, their fathers and their families of origin, stigmatizing them as "non-Aryans"<sup>123</sup>, and they were among those persecuted and victimized by the Nazi reign of terror. Their fathers had been active opponents of the National Socialists as early as the 20s and as politically active Jews were doubly in danger after 1933. Both were "taken into preventative custody" for the first time in the wake of the *Reichstag* fire of 1933.<sup>124</sup>

After years of political incarceration as a Communist and a Jew, Hilde Kaufmann's father was deported to Auschwitz, from where his family received notice of his death. Martin Kaufmann's father was released from a concentration camp in 1933, but was in danger of being re-arrested. He and his family emigrated to Belgium. Here, as a nineteen-year-old, Martin joined the Communist Resistance. Hilde survived in Germany. As a "first-degree *Mischling*", she was subjected to constant discrimination from 1933 on. Hilde and Martin managed to survive the Nazi period without being incarcerated in a camp. But the plans of the "Final Solution" threatened their lives too.<sup>125</sup>

---

122 According to the view of Jewish institutions in Weimar Germany, Hilde and Martin's fathers were therefore considered "dissidents", who were not recognized as Jews under civil law, although their mothers were Jewish (Oberlaender 1996, p. 18).

123 The classification into "non-Aryans" and "Aryans" came into force in 1935 with the "Nuremberg Laws". These stripped Jewish institutions and individuals of the right to decide who was to be considered Jewish. According to the criteria of the "ratio of mixed blood" of "Aryan" to "non-Aryan blood", four basic groups of "non-Aryans" were created: "full Jew", "part-Jew legally regarded as a full Jew", "first-degree Mischling" (the "mixed" offspring of Germans and Jews), and "second-degree Mischling". This categorization formed the basis for the degree of stigmatization, persecution and even murder of "non-Aryans".

124 At the end of February 1933, unknown arsonists set fire to the Reichstag. The National Socialists claimed this was the inception of a Communist coup d'état backed by the Social Democrats. In March/April 1933, over 25,000 people were detained and tortured without evidence, questioning or legal representation. Many were tortured to death.

125 For many years, the organs of the state- and party apparatus debated whether "part-Jews" should be subjected to forced sterilization or murdered as well. For technical and political reasons, however, the responsible authorities hesitated to include "persons of German blood" into the "Final Solution". From winter 1994/45 on, there were plans to compel "first-degree Mischlinge" to do forced labor (cf. Hilberg 1990, p. 69-84; p. 436-449).

The interviews with Martin and Hilde Kaufmann give a sense of the extent to which the "racial" discrimination and persecution, that they experienced as children and adolescents, was definitive for their biographies. But it is their anti-fascist family biography which is in the foreground in their stories.

The grandfather Martin Kaufmann<sup>126</sup> was the first son born to his parents after two sisters and he had a sheltered childhood in a small town near Rostock. His father had made a name for himself in left-wing liberal circles in the Weimar Republic and his mother worked as a housewife. Martin's father was of Jewish descent, but was christened a Protestant when he was just one year old. 1933 marked a turning point in Martin's carefree childhood: the nine-year-old was informed for the first time by a school friend that although his mother was "Aryan", his father was a Jew, and so he was no longer allowed to play with him. Martin says that he went home and told his father with conviction that he wanted to "*be like Mummy*". He says it was the last conversation of any significance that he had with his father before the latter's incarceration in a concentration camp.

In spring of 1933, Martin saw the SA arresting his father. Even today, he can hardly speak about this memory:

Martin: "...they had smashed the door down, they had axes. Then I saw (2) how they twisted my father's, um, arms, um, behind his back, and with the butt of their rifles (5) ((cries)) (5)

Interviewer: This image still haunts you today (5)

Martin: well (1) they-they, you know, beat him terribly (2)

Interviewer: And you were at the window above

Martin: I was at the window (3) I screamed very loudly (1) with a voice that was completely unfamiliar, "which" (2)

Interviewer: You were so beside yourself

Martin: Yeah, yeah (3) oh that was terrible, anything was possible now..."

After two months imprisonment, Martin's father returned home utterly weakened. He felt that he was in a hopeless situation and was afraid the Nazis would do something to his family. In his despair, he attempted suicide twice. Martin mentions in the interview that he only found out about this as a grown man. As a child, he had not understood why his father had been so distant to him after his release. At the time, he had wondered whether he was to blame for his father's behaviour. While he presents menacing situations that occurred later in his life more anecdotally and with greater detachment, here the biographer gives us a sense of the desperate fears and disappointments that he had to suffer as a child in 1933. We can assume that in later situations he tried to deny his fears or to overcome them on his own.

---

126 The author conducted two interviews with Martin Kaufmann in 1993.

In the interview, Martin links his being rejected by a school friend with his father's arrest, which occurred shortly afterwards. At that time, at an age when relationships outside of the family and acceptance by ones peers take on enormous importance, Martin wanted to belong to the dominant culture, a desire that was compounded by the fact that his unquestioning trust in a protective father was shaken with the onset of the National Socialist's policy of persecution. He began to identify with his non-Jewish mother, at first spontaneously, but presumably permanently. In the way he links and comments on these key experiences at the beginning of the interview, Martin indicates that he felt guilty about having distanced himself from his father's Jewish background after the latter's incarceration. In the next part of the interview, the biographer describes himself as a young man who was able to get close to his father by joining the anti-fascist Resistance.

On Mrs. Kaufmann's instigation, the family emigrated to Belgium in 1933. Despite economic difficulties, Martin experienced some relatively unburdened years there. His father worked as a writer again and remained politically active as a Social Democrat. Martin also joined a socialist youth organization. He speaks of having developed a desire to become active against the Nazis like his father. In 1940, at age sixteen, Martin experienced the invasion of the *Wehrmacht* as a renewed division of his family into those persecuted and those not persecuted. As he was still going to school at the time and his parents wanted him to graduate, he remained in Brussels with his mother, while his father and his two sisters fled to France. But as German emigrants, they were interned there.<sup>127</sup> With the help of friends, Martin's father managed to get out and hide in a village in the unoccupied zone, where he was able to escape persecution. He died of a heart attack shortly after the liberation without ever having seen his wife again. Martin's younger sister joined the anti-fascist Resistance after her release from the internment camp later in 1940, but then went back to her mother in Brussels and worked in a restaurant frequented by German officers. She became engaged to a *Wehrmacht* lieutenant who, though a member of the NSDAP (or Nazi party), disregarded the Nuremberg Race Laws and later became a member of the National Committee of Free Germany (NKFD)<sup>128</sup>. The couple were only able to marry after the liberation in 1945. Martin's older sister Lisa met an Italian Jew in the internment camp who was active in the Communist Resistance. In 1942, the couple had a

---

127 In the name of "national security", even before the invasion of the German Wehrmacht, some 100 camps were set up in France where "undesirable persons" were to be isolated from the rest of society. After the war began, mainly German emigrants were interned there. Under German occupation, the camps remained in use and their number was increased to around 400 internment camps. After 1942, thousands of Jewish internees were deported from them to the extermination camps (Mittag 1996, p. 11-43).

128 The Nationalkomitee Freies Deutschland (NKFD) was founded in July 1943 in the Soviet Union by emigrated Communists, trade unionists, workers, intellectuals and prisoners of war. The goal of the organization was to topple the Nazi regime and end the war.



child. Lisa also joined the Resistance after she was released from the internment camp. She belonged to a group who helped Jewish organizations in France attempting, with a great deal of success, to save Jewish children from deportation.<sup>129</sup> From Lisa Levi<sup>130</sup>, who now lives in Northern Italy, we heard parts of the family history that her brother Martin had not mentioned. She spoke of several relatives on her mother's side who became Nazi supporters after 1933, and of a cousin who denounced a Jewish shoemaker. Lisa presented herself less as a Resistance fighter, than as someone persecuted in the Shoah. Still, she found it very difficult to speak of the persecution she had experienced. She had to break off her story again and again to calm herself down. She described her terror, fears and feelings of helplessness in the face of the danger that threatened the children she cared for in the children's homes of Jewish organizations in France. To this day, she still finds it hard to bear that some of the children in her care were deported. Martin in distinction avoids talking about the persecution he experienced. Only when the interviewer asked did he mention the story of his sisters and the death of his father. In his presentation of his life story, he condensed the twelve years he and his family spent in emigration almost entirely to 1943/44. This is the period in which he became a member of the Communist party and was active in the Resistance against Nazi occupation. Martin repeatedly emphasized that he had not wanted to grasp the extent of the genocide: *"Something in us really resisted seeing it as a systematic policy of annihilation ordered from above. We often talked about it in anti-fascist circles."* Reading the book that Martin Kaufmann published in the mid-80s about the story of his emigration and the time he spent in the Resistance makes it easier to understand why he repeatedly spoke of his reluctance to grasp this: before he joined the Resistance, Martin narrowly escaped deportation in 1942.<sup>131</sup> During a raid, almost the entire Jewish hospital, where he was working as a nurse, was interned and taken to the Belgian camp of Malines. Martin managed to escape after being able to show his birth certificate as proof that his parents were registered members of the Protestant church. Many of his colleagues and patients, as well as Jewish children, who had been placed in the hospital, were deported to assembly camps and were presumably put on transports to Auschwitz not long afterwards.

---

129 In France, children under the age of fifteen were initially excluded from deportation and were separated from their parents when they were put on transports. But from July 1942 on, the authorities began deporting children over the age of two as well. Many of the children were saved, however, with the help of Jewish organizations and their non-Jewish helpers. They were placed in children's homes run by these Jewish organizations, disguised as "Aryan" children or hidden (Klarsfeld 1989; Klarsfeld 1994; Klarsfeld/Klarsfeld 1991).

130 Gabriele Rosenthal interviewed Lisa Levi in 1994.

131 From October 1940 on, the Jewish population was registered in registration lists. The first deportations to the east began in July 1942 (Hilberg 1990, p. 634; p. 638).

Having escaped deportation himself, Martin was forced to witness the deportation of others; during his time in the Resistance, he saw Jews from Belgium deported to the extermination camps of Eastern Europe. The mission he was entrusted with by the Communist Party of Germany, the KPD, was to engage in espionage and to recruit members for the Communist Resistance. He had to pretend to be a Belgian and applied to be a chauffeur at one of the military headquarters of the German *Wehrmacht*, which organized the transports of Jewish prisoners to the assembly camps and sent logistical supplies to the front. His mission required him to work regularly with the Nazis. For instance, he once had to take part in evacuating civilians whose buildings were needed by the *Wehrmacht*. Martin was hardly ever able to help pass on information to the sabotage units of the Resistance about the transport of inmates, as he only managed to catch sight of a few such documents and he was supposed to concentrate on transports of logistical supplies in his spying activities. This biographical constellation is presumably one of the reasons why Martin repeatedly mentions that he was not aware of the systematic nature of the genocide. It also makes it easier to understand why he talks about his experiences as a member of the Resistance and does not mention the raid on the Jewish hospital. It is easier for Martin Kaufmann to speak of the danger he was in as a Communist member of the Resistance than as a "part-Jew". He talks in detail about how he was denounced and imprisoned in 1944. He had been sentenced to death for high treason when he was freed in an attack on the prison by Belgian partisans. He fought in their ranks until the end of the war. He devoted a large part of his presentation to the death sentence he narrowly escaped and his experiences with the partisans. Martin's self-comprehension as a member of the Resistance allows him to achieve a stable biographical project that was not even shaken by the social upheavals in East Germany.<sup>132</sup>

Martin said little in the interview about his experiences of persecution, but also shed little light on the period after 1945 and his life as an East German citizen. This may be because the person interviewing him was a West German, with whom he may not have wished to share his experiences of East German socialism. His sparing remarks about his experiences after the liberation and his daughter's suspicions permit further assumptions. We know that after the war, Martin returned to West Germany, where he worked for the KPD. He worked as a journalist bringing war criminals to justice. His newspaper was closed down because of the Cold War and the banning of the Communist Party in West Germany. In the years that followed, he carried out "party work". He himself does not speak of this time. Our interview with his daughter Dorothee reveals that she only has a vague idea of what he actually

---

132 Oberlaender points out that many "non-Aryans" tried to compensate their subidentity as "Germans" by reinforcing other biographical projects (1996, p. 329).

did during these years. She remembers having lived under a false name for parts of her childhood, and suspects that her father did "*intelligence*" work. He confirmed this when she asked him whether it was true. At the request of the party, Martin Kaufmann and his family moved to East Germany in the early 50s. There he was offered a position in the Ministry of Foreign Affairs. He mentions that, in exchange for the anti-fascism of East Germany, he was prepared "*to take certain things into account*". We only discovered indirectly what he took into account. The biographer's detailed descriptions of the practice of prosecuting Nazis in East Germany reveal how much it weighed on him that, again and again, high-ranking functionaries were exposed as former Nazis there, too. Martin describes individual cases of de-Nazification which he implies were motivated more by reasons of outward appearance than by any real desires on the part of those in power.

Archive research permits further assumptions about what Martin took "*into account*": in a biographical reference book on forced emigrants under National Socialism, we discovered a note stating that in 1950, the former ruling East German Communist party, the Socialist Unity Party (SED), accused Martin Kaufmann of carrying out "American espionage". Martin may have been one of the emigrants from West Germany who were under the suspicious eye of the SED party. This is also suggested by statements made by his former KPD superior in the Resistance which we found documented in the former SED party archive. They testify to contacts between the "part-Jew" Kaufmann and the American allies. Martin's former superior was one of many SED party members who were asked detailed questions about their biography and their circle of acquaintances during the period when they were emigrants to the West. At that time, the SED was pursuing the goal of promoting Stalinist discipline and wanted to make examples for the benefit of potential "deviationists". Those questioned had to swear to absolute silence about the interview on pain of being expelled from the party and paying the consequences to their professional livelihoods (Kießling 1993, p. 120 ff.). It is still unclear whether Martin Kaufmann, who was still living in West Germany, was also interrogated. To this day, he refuses to allow his children and grandchildren access to his files.<sup>133</sup> This creates space for questions which - as we will see - later generations fill with suspicions and fantasies.

Whereas Martin tells the story of his life as if he had done so many times before, the grandmother Hilde Kaufmann relates her family and life story with far less routine.<sup>134</sup> She finds it hard to open up to her memories of the time

---

133 His grandson Alexander wanted to be released from compulsory service in the German armed forces on the grounds of his Jewish family background and wanted to do alternative service on a kibbutz in Israel. He asked his grandfather for his "VdN" files ("Verfolgter des Naziregimes"), which certify that Martin Kaufmann was persecuted by the Nazi regime, but Martin denied him access to them.

134 Hilde was interviewed in 1993 by Gabriele Rosenthal and Revital Ludewig-Kedmi on two

when she was persecuted. But in recent years she, too, has thought intensively about her childhood and youth under National Socialism. While Martin wrote a book about his experiences in the Resistance, Hilde wrote out the songs and poems of her father, who was murdered in the Shoah, so that her children could read them. She also commented on them in discussions with her daughter Dorothee. Hilde told us that reading these last testimonies was very painful and that she often had to interrupt her work. Unlike Martin's texts, her thoughts about the period of persecution are intended more for herself and the intimate circle of her family than for a wider audience. However, her daughter Dorothee published the songs and poems Hilde's father wrote in a book, which also depicts his family history before and during the period of persecution. Like her husband Martin, Hilde was born in 1924. Her father came from a Jewish Orthodox family, but he broke his ties with them as an adolescent, moving away from his East Prussian hometown to Augsburg and joining the German Communist Party (KPD). In Augsburg he met his future wife. Because she was not Jewish, Hilde's mother was ignored by her parents-in-law at first. It was not until Hilde and her brother were born, that the relationship became more relaxed. At a distance, but naturally, Hilde grew up with both the Jewish tradition of her paternal grandparents, and with the Catholic religion practised by her maternal grandmother. At home she had an atheist upbringing and became acquainted with her father's Communist views.

For Hilde, 1929 was a biographical turning point. Her father was expelled from the KPD and lost his job as a librarian in a worker's cultural organization. He had refused to go along with the theory of "social fascism" which the KPD leadership used to claim that Social Democracy was paving the way to fascism and therefore the archenemy of the working class. Hilde remembers the family's sudden poverty, but also the help they received from their Jewish relatives. In the 30s, when these relatives were exposed to increasing Nazi repression and eventually had to move into the ghetto, Hilde's mother maintained contact with them. She supported her husband's family as well as she could by sending them money and food packages. Unlike Martin, who experienced the division of his family through Nazi "racial" policy and sought to identify with things outside of the family, Hilde experienced the growing solidarity and intensity of the bond between the Jewish and non-Jewish parts of her family. But outside the family, she found herself in ever-greater isolation. Hilde internalized the ideal of a bond of solidarity to the family, whereas Martin mainly oriented himself on ideals outside the family that concerned society as a whole. While Hilde tends to desire a harmonious relationship between all family members, Martin has a tendency to ban family members who do not share his political convictions from the intimate family circle.

Like Martin's father, Hilde's father was arrested by the Nazis in 1933 and imprisoned in a forced labour camp. Despite all of the warnings from his friends, who urged him to emigrate, he remained politically active after his release. Over a number of years, he and a group of like-minded activists managed undiscovered to expound Marxist teachings and hold political debates about possible forms of organization of the workers' parties. It was because of these activities alone that the Gestapo arrested him for the second time in the mid-30s. After horrific interrogations, a court sentenced him to ten years imprisonment. In the early 40s, Hilde's father was deported to Auschwitz.

Unlike Martin, who says little of his father's fate, Hilde weaves her life story - a childhood and youth full of fear, ostracism and a destroyed professional career - into the story of her father's incarceration. Again and again she relativises her own suffering under National Socialism with descriptions of how much more her father had to suffer. Even at the time when she experienced these events, Hilde's life history was closely connected to her father's. Day-to-day life in her family revolved around his fate: *"It was really terrible, really terrible for us, too ((cries)). Here and there we heard details from comrades who'd been released about the horrific torture (1)."*

Her rare visits to the prison were long hoped-for but increasingly dreaded. Physical contact and speaking openly were no longer possible, rather everyone insisted on how well they were. As Hilde observed, there was *"less and less"* of her father all the time. She identified with his fate so much that her body's defences grew weaker and she fell seriously ill. She had to be treated in a sanatorium. While she was there, Hilde was told that her father had been deported. Shortly afterwards, the family was informed that he had *"died in Auschwitz"*. Hilde was informed of her father's death by a letter from her mother, and was left completely alone with her feelings. With horror, she realized that alongside the pain she felt relief: *"I thought now father doesn't have to suffer so much and I - I can just say now: "My father's dead", when anyone asks me about him."*

Hilde indicates that at the time her ambivalent feelings blocked her grief. When she thinks of her father's death today, she has a specific image in her mind's eye. She sees a lonely man lying on a bed of straw waiting for death. This image helps her avoid thinking about her father being murdered in the gas chamber. Her fantasy of a lonely man dying is presumably an expression of her despair at the circumstances in which her father was snatched away from his family. But it also corresponds to the life history of her father, who was ostracized because of his political convictions and his Jewish background. Unlike his non-Jewish comrades who were incarcerated with him, as a Jew he had to spend several years in solitary confinement, and as a Jew he was put on a transport to Auschwitz.

Just months after the death of her father, Hilde found out that the Nazis had murdered her aunts and uncles on her father's side. When this news

reached the family, the surviving relatives could barely grasp the fact that their relatives had become the victims of systematically organized mass murder. Even today, Hilde finds this hard to grasp. Like Martin, she points out that she only found out about the Nazi's systematic policy of extermination after 1945. In the interview, Hilde cannot recall the dates and circumstances of her relatives' last letters, but feels the need to repeatedly refer us to her daughter Dorothee, whom she says has researched their history in more detail. In the interviews with Hilde it becomes evident that her grief about the loss of her relatives is still with her today; it also emerges how relatively little she allows herself to express this grief. Her daughter Dorothee has taken on the task of researching and documenting the history of her mother's Jewish relatives. But as we will see, this close examination of the family history has also been a source of considerable conflict in the relationship between Dorothee and her parents.

If we try to get a sense of Hilde's daily life during the period of persecution, the great effort she must have made to conceal her Jewish background and her Communist family becomes apparent. She could only share her constant fear during the years of the Nazi reign of terror with the closest members of her family, but lived apart from them most of the time. She had to quit school, hardly dared to look for work and was dismissed on numerous occasions in succession because of her status as "first-degree *Mischling*". In 1942, she and her brother had to give the Gestapo their photographs and were registered at the employment office as "part-Jews". As the Kaufmann family repeatedly told us, Hilde's brother cannot remember any cases of discrimination at school or at work. Hilde, on the other hand, still suffers from her fears and insecurities. But she tends to blame herself for this, rather than seeing it as a consequence of persecution: *"No one stopped me getting my high school diploma after 1945 and going to university. But I wouldn't have managed it. I know that. That's the awful thing, I didn't think I was capable of anything. I don't know whether that may be from the Nazi period, too."*

After 1954, Hilde had only one desire: to escape her isolation and no longer feel like *"an inferior human being"*. However, she and her family felt a profound distance to the Germans who became perpetrators and collaborators in the Nazi system. Joining the KPD seemed like a way out, as most comrades had been in the Resistance or in emigration. And in Hilde's family, KPD membership was seen as her father's legacy, although her father had been expelled from the KPD in 1929. For many years, Hilde avoided talking about this expulsion. Foremost in the memory of the Kaufmann children as well is that Hilde's father "perished" in Auschwitz as a Communist anti-fascist.

Hilde met Martin Kaufmann in West Germany after the liberation. In him, she had encountered a man who was close to her in terms of his family history and his political past. If Hilde had previously always relativised her own suffering under the Nazi reign of terror in comparison with her father's

sufferings, she now compared her experiences with those of her husband and came to the conclusion that she herself had been exposed to far less danger: *"He'd fought as a partisan. He'd been in the most dangerous situations, compared to mine, uh (1), that is (1) the way I, had to see it basically nothing at all really happened. And he, he'd been practically sentenced to death."*

The stories of her husband and her father's involvement in the Resistance are not only more dramatic than her own history in Hilde's eyes. They also dominate the family stories of the daughter and the grandson as we will see.

The biographer interlinks the story of her life as a housewife and mother in the post-war period with the story of the professional career of her husband, whom she builds her life around. It is only in the second interview with Hilde when we ask that we discover that several years after the war ended, the consequences of the emotional strain her mother was under during the period of persecution had made her ill. Hilde said her mother suffered from intense trembling and a persecution complex and was unconscious for a certain period of time. Hilde's mother was admitted to a psychiatric ward. The doctors there did not see any connection to her past, but rather diagnosed purely physical causes. Hilde explains that during these years, she herself had been primarily occupied with starting a family and then with the move to East Germany. Whereas Martin Kaufmann primarily accounts for his choice to live in East Germany with his anti-fascist mission, Hilde Kaufmann cites her existential fears. She reasons that she felt safe in East Germany, where Politburo members had been in concentration camps themselves. When the interviewer asked her about her experiences of anti-Semitism, the biographer replied that she had not experienced anything of the kind in East Germany, that her circle of friends was entirely composed of Jewish former emigrants who had been suffered persecution.<sup>135</sup> We can sense that in a certain way she sees her circle of friends as offering her protection from an environment that she perceives as hostile. When asked whether the persecution in her past had left its mark on her life now, Hilde initially answers in the negative. Then she mentions the exaggerated fear with which she bound her children to her. She explains, however, that this is a *"typically Jewish fear"* that she inherited from her father. Hilde only suspects that this fear could have something to do with her experiences during the Nazi period in connection to the period after the Wall came down:

*"My children have remained part-Jews, according to this racial theory. I mean, I really (1) never really thought that that could somehow happen again (1) but recently I'm not so sure any more with so much of this hatred of foreigners around. And anti-Semitism is also (1) very much (2) on the rise (1) again."*

---

135 On the closed nature of the emigrant milieu in East Germany, see for instance Mitscherlich/Runge 1993, p. 17ff.

The formulation "*on the rise again*" indicates that Hilde was aware of anti-Semitism under the East German regime, but found it easier to rationalize away her fear of it.

In the 80s, Hilde and Martin Kaufmann began to allow their children indirect and direct access to parts of their family history: after he had retired from professional life, Martin Kaufmann published a book on the story of his emigration and the time he spent in the Resistance, and Hilde Kaufmann wrote out her father's songs and poems that had lain in a drawer for decades. The couple also visited the Auschwitz memorial for the first time. Timewise, their biographical work corresponded with a tendency evident in West Germany towards the - if fragmentary<sup>136</sup> - biographisation of memory of the National Socialist era. Like many other biographers, Hilde and Martin Kaufmann began thinking back to their childhood and adolescence after retiring from professional life. Their intensive preoccupation with this phase reactivated the process of grieving for the loss of their dead and murdered relatives which they had had to suppress, especially during the period of persecution.

The period after the political changes of 1989 opened new opportunities for giving space and symbolic expression to the commemoration of the dead: Hilde registered her father's name and his picture along with the names of her Jewish relatives in Yad Vashem. Since 1989, the Kaufmanns have been attending events held by the newly founded Jewish Cultural Centre in East Berlin. This biographical work, which is sometimes very painful, can be interpreted as an offer to the generation of the children and grandchildren to open up the dialogue about the family past.

Dorothee, the second-eldest daughter of the Kaufmann family, has also concerned herself in some detail with the family history since the 80s. During her research, she came upon family secrets kept by her parents for years. Dorothee was able to shed some light on some of them, but others remain unsolved riddles to this day.

### *The daughter Dorothee: delving into her parents' taboos*

The daughter Dorothee Liebig was born in 1949.<sup>137</sup> She has an older sister and a younger brother. She and her sister were both born in West Germany and were old enough to be aware of the family's move to East Germany in the early 50s. Dorothee was five years old at the time, and was sorry to separate from her two grandmothers, and from her aunts and uncles. The siblings grew up in East Germany without close relatives. The children were given the mes-

---

136 Fischer-Rosenthal describes biographies in Germany as "fragmentary texts of memory" (1995, p. 79).

137 Gabriele Rosenthal and Revital Ludewig-Kedmi interviewed Dorothee Liebig twice in 1993.



sage, particularly from their father, that there were both Communists and "unpolitical" relatives among the West German part of their family. The husbands of Martin's sisters, for example, belong to the latter group. One was a soldier in the *Wehrmacht* during the Nazi period and later "only" active in the German Social Democratic Party, and the other, a former member of the Resistance and a Jew, left the Italian Communist Party in the wake of the Hungarian Uprising of 1956. Martin Kaufmann did not try to hide from his children the contempt he felt towards these relatives.<sup>138</sup> When their father Martin went abroad on Ministry business for a year shortly after the Wall was built in 1961, the East German government refused to allow twelve-year-old Dorothee and her sister to go along with him. Both stayed behind in their parents' apartment. Dorothee remembers that during this period, she defended the building of the Wall in class using arguments that she had heard at home and, as a result, ended up in the position of outsider. She missed her parents greatly and felt abandoned by them. When they came back, the old untroubled relationship between parents and daughter could not be recreated. Dorothee found it hard to fit back into the role of the little daughter which led to considerable conflicts, mainly with her mother. Hilde worried a great deal about her daughters. Dorothee imagines that her mother found it hard to see her becoming independent without thinking of the hard times and missed opportunities of her own adolescence. Politically, Dorothee followed in her parents' footsteps and joined the SED at the age of seventeen. But Martin and Hilde responded with reserve. Speaking of her father, Dorothee explains: "*Of course he was quite aware of the whole dark side of this party membership, which he had not told me about yet at that point. So I was a victim of his powers of persuasion.*" In later years, Dorothee sometimes sensed her parents' ambivalent relationship to the party and how out of place they felt in East Germany. In the years that followed, she distanced herself far more aggressively than Hilde and Martin from the politics of the SED, but nonetheless remained a member until 1989. Dorothee married in 1971 while she was doing a teacher training course and became the mother of a daughter and a son. She chose a partner who was perceived as an outsider in her milieu of origin because he was a musician who was critical of the system and did not belong to any party. It was particularly in her discussions with her husband Michael that she began to call into question her socialization and her family history, bringing her into strong conflicts of loyalty with her parents.<sup>139</sup>

---

138 Later generations of "mixed" families often perceive their family of origin not as a unit, but as two or more families. The different experiences and perspectives under National Socialism within "mixed" families (depending on whether someone was persecuted, a collaborator, a sympathizer or a member of the Resistance) tended to leave their mark (Oberlaender 1996, p. 341). In the Kaufmann family, as in other families with a Communist background, we notice that differing political convictions are particularly emphasized after 1945 to mark divisions within the family.

139 Oberlaender describes the tendency of descendants of "non-Aryans" persecuted by the

Dorothee's presentation of her family story revolves around the theme of "the blocked dialogue with my parents about the Nazi period and the East Germany era". In the interview, the biographer particularly emphasizes experiences in her life history that are linked to questions her parents refuse to answer and to family secrets. Dorothee first began to deal with the history of her Jewish maternal grandfather in the 80s. She compiled his songs and poems into a book and researched the historical background of his biography. In doing so, she began to identify with him and to critically compare her version of his history with the stories her mother told her. She repeatedly argues in the interview that she only found out this or that part of the family history in the 80s and with considerable difficulty. One such discovery was the realization that her grandfather had been expelled from the KPD in 1929. Dorothee said she was:

*"...obsessed with this thought that that would have been someone I could have talked to about the things that move me. What would it have been like in 1968 if there'd been someone sitting at the dinner table who would have supported you in the things you had doubts about or protested against - everything would have turned out very differently."*

In 1968, she began to doubt the politics of the SED. It was in the context of the Prague Spring that Dorothee first heard about the Slansky trial in Czechoslovakia and corresponding anti-Semitic persecution in East Germany in the early 50s.<sup>140</sup> Dorothee tells of how in response to her questions at the time, her father merely expressed the opinion on the accused in the Slansky trial that *"their sentence was just"*. She adds that since then she has been interested in the circumstances surrounding this tribunal. It was during the Prague show trial and its aftermath that her family moved to East Germany. The background of this move is still only vaguely clear to Dorothee. It is another family taboo. She says that while her father admitted working for the *"secret service"* during this time, she never found out any more about it than that. Dorothee says that today, meaning after the changes of 1989, the atmosphere is no longer right for asking such politically explosive questions. While Dorothee began to air the secrets in her family, her daughter Sandra, as we will see, developed definite fantasies about some of her mother's questions about their family history.

For Dorothee, another of the taboos in her family is their Jewish family background. She says she was *"always told by other people that we're Jews"*.

---

Nazis to choose partners as a protest against the dominant culture. Oberlaender's theory is that in doing so, the descendants indirectly and unconsciously adopt a "stigma identity" like the one forced on their parents before them. The theory goes on to say that their choice of partner also often expresses a need to have their own construction of reality called into question (1996, p. 346-349).

140 For more on the Slansky trial and its consequences, cf. Chapter 4.1.

The biographer, who had long believed that only members of the Resistance were in concentration camps, began to look at her Jewish family history in connection with her grandfather. Motivated by a desire to break with the SED, she attended the newly-founded "We-for-us-group" at the Jewish Community Centre, whose organizers specifically invited her generation to get a better understanding of themselves. Dorothee says that at the time she asked herself: "*Why didn't I ever allow myself that, why did I always go to the others?*", but "*as if I were paralyzed*" she remained a member of the SED. In this phase of intensive preoccupation with the history of her grandfather's persecution, at the age of almost forty, Dorothee thought about what this part of her family history meant for her. For the first time in her life, she imagined that she herself could have suffered the same fate as her grandfather and thus gained access to her Jewish family history. But she is almost reluctant to allow herself feelings of sadness about the violent death of her grandfather: "*I guess maybe it's a bit silly that I'm crying because my grandfather was murdered, maybe it isn't my pain at all but something I've picked up.*"

Like her mother, Dorothee imagines that her grandfather died alone and "*of the conditions*": not in a gas chamber. She herself developed a fear of going into locked spaces that has been with her since childhood. This symptom, which can be interpreted as an expression of fear of annihilation, is something we find again and again in second and third generation relatives of people persecuted in the Shoah.<sup>141</sup> Dorothee does not make a connection between her fears and the persecution in her family past. She does, however, link another striking behavioural pattern to her family history in the interview: as an adolescent, Dorothee developed specific death fantasies around her father's history. During the year that her parents spent abroad, she used to read poems and letters from a book by people sentenced to death. While she did this, she used to imagine "*intensively*" what their last hours of life were like and thought of her father, who was also condemned to death after his imprisonment as a member of the Resistance. Dorothee explains that her father Martin never spoke to her of his fears: "*I could never get through to that place with him*". She says she had to imagine the fears herself. She describes her father's stories about fighting in the Resistance as "*nice legends*", as "*fairy-tales*" that she knew mostly from his published autobiography.

Prompted by experiences in her own family, the biographer has been critically examining East Germany's glorification of the anti-fascist Resistance for many years. In her classes, during guided tours of former concentration camps and in publications, she has repeatedly pointed out that by over-emphasizing the heroic history of the KPD, other resistance groups and people persecuted on other grounds have been forced into oblivion. It is therefore all the more astounding that in presenting her father's story in the interview,

---

141 Cf. Chapter 1.2 for more on the impact of persecution on the second and third generation.

Dorothee focuses on his arrest, his imminent death sentence and his surprising liberation by the partisans. She does not tell us that Martin only just escaped deportation when the Nazis raided the Jewish hospital where he was working. In fact, Dorothee mentions that the hospital was "*closed down*" in a subordinate clause.

Like in his story, her father's experiences of persecution as a "part-Jew" are not a theme in Dorothee's version of the family history either. In her description of her death fantasies and in the reconstruction that she presents of Martin's story, Dorothee emphasizes the danger her father was exposed to as someone persecuted on political grounds. Throughout the interview, Dorothee emphasizes the political persecution suffered by her relatives. This is also expressed by Dorothee's difficulty seeing her mother as a victim of persecution in any way. She responds in the negative when asked whether she believes her mother was afraid of being deported at the time and at another point in the interview argues that: "*She also sometimes felt discrimination where there wasn't any, she's really always been afraid.*"

Dorothee describes her mother's fears and illnesses and says she felt oppressed by them, especially as an adolescent, and that they gave her a bad conscience, but she depicts them as her mother's own personal problem: "*Well I related these psychosomatic things to the present of that time that she felt neglected by my father. I didn't really relate them to the past.*"

The second generation of this family, too, tends to address the theme of the parts of the family history that are linked to the Shoah as an individual fate or a subjective problem. In contrast, the story of political Resistance is remembered as the fate of the family and therefore structurally as a collective fate. The presentation the generation of the grandparents gives of their own story adds to this. Dorothee, too, is much more preoccupied with a critical examination of the glorification of the Communist Resistance in East Germany and with the anti-fascist biography of her grandfather and father than with her parents' experiences as people who were persecuted in the Shoah.

All interviewees in the Kaufmann/Liebig family spoke of the heated political disputes that occasionally arise between the generations of the grandparents and the parents. Martin and Hilde Kaufmann in particular give Dorothee's husband Michael Liebig most of the blame for these disputes. Over half of the family interviews, that we conducted with Dorothee and her parents, revolved around Michael having made his wife a stranger to her own family.<sup>142</sup> Dorothee is still trapped in a conflict of loyalty between her husband and her parents today.<sup>143</sup> Over 20 years ago, when she introduced them to Michael, then her boyfriend and not a member of the party, he affronted

---

142 Gabriele Rosenthal and Bettina Völter conducted a family interview with the constellation of Hilde, Martin and Dorothee in 1994.

143 Boszormeny-Nagy discusses this type of conflict of loyalty as a result of children taking on responsibility early on and thus remaining bound to their parents (1973, p. 161).

Dorothee's father with his critical comments about the East German regime. On that same afternoon, when Dorothee then started questioning the validity of the student work programmes customary in East Germany, Martin Kaufmann turned to his daughter and said: *"When the going gets tough, you'll be on the other side of the barricade."*

Michael has not forgotten this sentence. He still reminds his wife about this first meeting today. In the years that followed, Michael and his parents-in-law fought repeatedly. Dorothee felt torn between the two until 1989 just before the Wall came down when Michael's parents-in-law forbade him to darken their door again. The reason this time was a dispute about a family affair. Aiming his comment at Michael and Dorothee, father-in-law Martin Kaufmann is said to have remarked: *"We just have to be careful that you two don't get into a position of power because you would put people who think differently than you in camps."*

Dorothee was deeply hurt. She says she felt *"completely numb"*. She and Michael interpret Martin Kaufmann's words as a sign of fear about the imminent demise of the East German state. In the interview, Dorothee wonders whether she should approach her father again more sympathetically, bearing this perspective in mind.

### *The Liebig Family: The "Break between the Generations"*

Dorothee's husband Michael (born in 1941)<sup>144</sup> is among those of our interviewees with whom we were able to experience tangible biographical changes. We met Michael at a time when he was considering whether he should contact his father, who he had not seen for 30 years. The intensive reflecting he did about his life story during the interview resulted in him deciding to write to his father. His father responded promptly and telephoned Michael to arrange to visit him. Although he had only lived a few kilometres away from his son and his son's family all those years, this visit was the first time Herbert Liebig, then 80 years old, had met his daughter-in-law Dorothee and his grandchildren Sandra and Alexander. A few weeks later, we had the opportunity of conducting a family interview with the grandfather Herbert, his son Michael and grandson Alexander Liebig. I will go into this family dialogue in more detail at the end of this section. But first, let us look at the family and life history of Michael and his parents Herbert and Elisabeth Liebig.

Michael chose the *"break between the generations"* as his theme for the individual interview. He introduces himself as someone who - unlike his wife - takes a resolute approach to *"coming to terms with the past"*: *"I'm very aggressive and very consistent about it. I allowed my father to die in spirit. I*

---

144 Bettina Völter interviewed Michael Liebig in 1993 on two occasions.

*just disowned him as my father because of his human weakness. And Dorothee continues to have close contact with her parents despite all these remarks."*

Michael's justification of why he stopped having contact with his father combines family reasons with political categories again and again. In particular, he reproaches his father for the latter's political about-face after 1945: *"He was a very intelligent but very uncontrolled and aggressive guy, who acted like a little Hitler and then turned into a little Stalin after the post-war re-education."*

In the interview with Michael's mother Elisabeth Liebig<sup>145</sup>, we discover that during the Nazi period, her divorced husband Herbert tried to win over her and her Communist-oriented father: *"Nazism is a superior kind of Communism' was one of the things he came out with."*

Elisabeth Liebig speaks of how after the war Herbert was suddenly *"as if possessed"* by Marxism-Leninism. Michael does not like to recall the political education his father tried to give him in the post-war period. He said it was all the less credible, because his father had been a Nazi just a few years before. Herbert had demanded of his wife that she greet people with "Heil Hitler" and had believed in the "Final Victory" until the very end. Michael asserts the political convictions of his father in the Nazi period without ever having spoken to him about them directly. He says Dorothee read Herbert's letters from the front when he was a prisoner of war, saying he could *"not deal with them"*. Michael explains: *"Everything I know, I know only from hearsay."*

The grandfather Herbert Liebig<sup>146</sup> himself tells an unpolitical biography full of anecdotes, most of them about his affairs with women, his experiences in the war and as a prisoner of war. We get to know the life story of a collaborator in National Socialism who saw an opportunity for his own professional advancement in East Germany after 1945. As a trained craftsman, Herbert Liebig was able to study at the Teacher Training College in East Berlin when he returned from the war, even though he had not graduated from high school. Subjected to intensive recruiting by SED party comrades here, he joined the SED in 1950 and moved to East Berlin with his family. The Marxist-Leninist view of the world and its political practice suited him and he began to work towards a *"better Germany"*. He had a sense of being needed to rebuild the country and took the opportunities offered him. Because of the lack of qualified staff, as a college graduate Herbert was promoted directly to the position of school superintendent, with 50 schools under his jurisdiction. He remained in a key position until he retired.<sup>147</sup>

---

145 Gabriele Rosenthal and Bettina Völter interviewed Elisabeth Liebig in 1993.

146 Gabriele Rosenthal and Bettina Völter interviewed Herbert Liebig in 1993 in two individual interviews.

147 Herbert's rapid career rise is typical for the "career advancement society", as one can describe East Germany in its initial phase (Niethammer et al 1991, p. 45). The brain drain of

We can consider this self-presentation of the father and the accusations of his son as typical for the relationship between the generation who were young people during the Weimar period and the generation who were children during the war (Rosenthal 1997). The parent generation, born between 1906 and 1920, were adults during the Nazi period and as such had leading roles in the political organizations, the economy, the *Wehrmacht* and the extermination machinery. Empirical analyses show that today they feel the need to present themselves as "victims" of Hitler or of the Allies. People of this generation tend to portray the twelve years of National Socialism in a thematic field of "Our Suffering in the War". In contrast, Nazi crimes are not usually mentioned in the interviews.<sup>148</sup> Focusing on this aspect allows the interviewees to avoid touching on the theme of their own implicated guilt. However, it also corresponds to the biographical relevance that the war had, particularly for this generation. The empirical comparison with other generations shows that people of this generation had the greatest difficulty adapting to everyday civilian life after the war was over.

Their children, who were born between 1939 and 1945, in what is known in Germany as the "generation of '68", or - more appropriately - the "generation of war children"<sup>149</sup> are regarded as the "Fatherless Generation", as they grew up at a time when their soldier fathers were absent from the family system. As young people, they were best known for accusing their fathers of the crimes committed during the Nazi period, without generally knowing any concrete facts about them.<sup>150</sup> As we can see from this case study as well, this accusing stance generally tended to lead less to the parent's generation describing concrete facts and experiences, and more to them concealing these even further.<sup>151</sup> At the age of 22, Michael Liebig broke off contact with his father and thus with the dialogue about his father's past, as well. While a parallel emerges here to the intergenerational dialogue between the generation of those who were adolescents in the Weimar period and the '68 generation in West Germany, the contents of the accusations differ regarding the period after 1945. While the parents' generation in West Germany had to answer for the great silence surrounding the Nazi past, Michael Liebig accuses his father of exchanging National Socialist convictions for Stalinist ones after 1945. If

---

qualified personnel, de-Nazification and the social restructuring process gave members of the lower social classes in particular opportunities for meteoric career rises (Meuschel 1992, p. 59; Schlegelmilch 1994, p. 39f).

148 Cf. the case study of Hans Seewald in Chapter 5.

149 The experience shared by the generation born between 1939 and 1945 is experiences of war in their early childhood (Rosenthal 1997).

150 In contrast, Eberhard Sonntag (Chapter 5) represents a generational unit of "war children" distinguished by an uncritical bondedness to their fathers.

151 Tilmann Moser describes it as tragic that the '68 generation' "delayed a coming to terms with the past, in the sense of being able to speak about it in a safe space, by another one or two decades." (1992, p. 401).

we examine his life history, it becomes clear that it is precisely the period after 1945 that generates the greatest amount of conflict in the relationship between father and son.

Michael Liebig was born in Berlin in 1941, at the end of the third year of the war. One year after his birth, his mother fled with him from the city and its air raids to the countryside. His father remained in Berlin where he worked as a specialist in the armaments industry. Michael's sister was born in the country in early 1943. During his wife's second pregnancy, Herbert Liebig begot a child by a holiday acquaintance. Herbert and Elisabeth's marriage was very much put to the test by this. The children sensed this when their father came to visit them every two to four weeks.

In 1944, when Michael was three years old, Herbert Liebig was called up as a sergeant (*Unteroffizier*) and sent to the Western front to take part in the *Wehrmacht's* last large-scale offensive.<sup>152</sup> He was taken captive and held as a prisoner of war for two years. Michael was six years old by the time he saw his father again. He was a stranger to Michael and a rival. Michael had already begun to take on the role of the man in the house<sup>153</sup> and he rejected his father for a long time. Herbert Liebig was unable to respond with understanding to his son's mixture of childish overconfidence and independence. He had lacked a role model of a balanced, caring father himself.<sup>154</sup> Herbert tried to get his child to respect him by humiliating and beating him. Elisabeth Liebig still reproaches herself today for not coming between her husband and her son.

It emerges in the analysis of the interview with her that the abuse of her son touched on her own childhood trauma: between the ages of six and twelve she experienced her mother becoming ill with multiple sclerosis and several times trying to take her own life. One day in February 1933 when Elisabeth came home from school, she found her mother dead in the kitchen in front of the open gas tap. The way she tells of her mother's suicide attempts gives a

---

152 The "Ardennes Offensive" towards Antwerp was launched in December 1944 and pushed back by the Allied forces at the end of January 1945. The aim of the offensive was to achieve a "change of course in the Western operation" and to physically "annihilate" the Allied troops in Alsace with a "wave of terror and horror". In the course of the Ardennes offensive some 20,000 soldiers were killed in all on both sides, some 80,000 wounded and over 40,000 soldiers were taken prisoner (Schumann et al 1988, p. 124-139).

153 Children whose fathers were away from everyday family life for many years during the Nazi period and afterwards as prisoners of war were often - overtly or covertly - recruited by their emotionally and physically overburdened mothers as confidants, and boys were even recruited as substitute husbands. The generational boundaries were thus often blurred. The children turned into "bound delegates" of their mother and were overtaxed with "impossible missions" (Stierlin 1981, p. 381f).

154 Herbert's father became an alcoholic after he returned from World War I and in his behaviour towards his son he was authoritarian. Thus, much like his son Michael, Herbert also experienced the absence and return of a father who had been defeated and morally deprived of power.



sense of how little empathy Elisabeth has for herself. This suggests that as a young girl she reacted to her mother's suicide by blocking it out emotionally and was unable to grieve the loss of her mother. As a result of suppressing this grief, Elisabeth found it hard as a mother to empathize with what her son was going through.<sup>155</sup> Elisabeth was very attached to her husband, whom she met as a young girl shortly after the death of her mother. Even though he began an extramarital relationship after returning from the POW camp, she tried to keep the marriage going. She and the children followed Herbert when he moved to East Berlin (GDR) in 1951. But Elisabeth was not prepared to tolerate her husband's new love affair there. She filed for a divorce. Michael was eleven years old when his father moved out. He felt an initial sense of liberation that he no longer had to take part in meetings of the Communist Party Youth Organization. As an adolescent, Michael felt an irrepressible urge to assert himself in physical fights and rebellious protests during his apprenticeship. He was "banned from Berlin" in the early 60s because of his defiant attitude and was sent to the south of the country for a year. We can assume that the energy and anger that emerge from Michael's descriptions can also be interpreted as a reaction to his experiences in the family.<sup>156</sup>

Michael finally broke off contact with his father when Herbert refused to support him financially during his apprenticeship, at his second wife's instigation. However, his conflict with Herbert never ceased, not even during the period of manifest silence. Michael dealt with his conflict in poems and songs and published them in the hope of getting through to his father. He became a professional musician and later worked as a singer-songwriter. Michael continued to live with his mother until shortly before he got married at the age of 25. Michael had hoped that in marrying into Dorothee's family "*I would be able to experience a new father in her father*". But he quickly realized that as a non-party member, he was not the Kaufmann family's desired son-in-law. Michael describes the relationship his father-in-law had to Dorothee as a love affair that, as the successful rival, he brought to an end. He says Dorothee's father Martin let his daughter be taken away from him "*without putting up a fight*". The two men clashed at one of their first encounters. When Martin mentioned that he worked at the Ministry of Foreign Affairs, Michael remarked tersely: "*Oh, a big shot*". He went on to say that the language of the SED party was the language of the "*Third Reich*". Martin Kaufmann was outraged and left the room with the parting shot: "*And we risked our necks for this.*"

---

155 Lily Pincus describes the phenomenon of lack of compassion as a consequence of "suppressed grief" (1978, p. 269).

156 James L. Framo cites observations in family therapy that indicate that children can "react with anger and later with attacks on the establishment" if the generational borders in their family were blurred and they themselves were allocated parental functions as children. (1972, p. 345).

Michael also had conflicts with his mother-in-law Hilde. He said she had put her husband's needs too much before her own, and had tried to interfere in Dorothee and his affairs. Referring to Hilde's childhood and youth, he explains in the interview: *"You can understand her erroneous behaviour when you know how she grew up, the social problems that she lived with, the narrowness (2), the way her father oppressed her."*

Here, Michael makes Hilde Kaufmann's father the active agent who oppresses his daughter and is therefore basically to blame for her overprotectiveness. He tries to understand his mother-in-law's behaviour through her biography, but in doing so steers attention away from the persecution in her history and thus unintentionally exonerates the real perpetrators.

Michael's relationship to his parents-in-law was ridden with conflict from the very beginning and, after a number of years, finally led to his refusing to have any further contact with them.

The case analysis indicates that both Michael and his wife Dorothee tried to loosen their ties to their family of origin with the help of the other partner. In doing so, Michael in particular settled the ensuing conflicts openly which led to a break in contact between Michael and the parents' generation for a time. Dorothee and Michael make this break a key theme in their interviews. Despite all of the differences, there are striking parallels in the family and life histories of the two partners. Both Dorothee and Michael grew up with mothers who had to deal with the early loss of one of their parents and who were blocked in their grieving process by difficult biographical constellations. In forming a close bond to their husbands, both Hilde Kaufmann and Elisabeth Liebig sought a substitute for their lost parent. Dorothee and Michael both suggest that during their childhood they experienced their parents as a unit that they were excluded from. They felt abandoned and tried to compensate for their feelings of loss by behaving like adults prematurely.

Like his wife Dorothee, Michael has been dealing intensively with the history of the Shoah and the theme of *"conflict between the generations"* since the mid-eighties. He says this has eased the political dispute that had always existed between himself and his wife. Michael tells of their visit to Auschwitz together, which greatly stirred him up emotionally. He was particularly preoccupied with the spectator perspective of the people living near Auschwitz. He imagined the hopelessness of the camp inmates in view of the fact that they could not expect any help from outside. In the interview, Michael links this spectator perspective with the distanced reports he is used to hearing from his mother about the *"disappearance of Jewish classmates"*. He sees his mother as being *"hard-hearted"* in this context. In Elisabeth's interview with us, she also mentions that *"girls disappeared"* from her class. She sums it up like this: *"That's all done on the quiet, isn't it? The whole Jewish thing and all that, right? It didn't concern us really."*

We can assume that one of the reasons Michael is affected by statements of this kind coming from his mother is because, as a child, when he needed support against his father, he himself experienced her as an apparently uninvolved spectator.

Michael stresses that it was only through contact with Dorothee that he heard more about the Shoah and its aftermath:

*"If my mother mentioned memories, than just that she had her suitcases when the war was over, that some Pole wanted to steal her suitcases, that was the only thing we heard as children about Poles, the suitcase-stealing Pole, and about about Jewish (1) um nothing was ever said."*

Michael explains in the interview that he has given up talking to his mother about her experiences during the Nazi period because her stories, that only ever featured her as a victim, used to regularly make him furious.

The changes in 1989 brought on a biographical crisis for Michael. He became unemployed and at the age of nearly 50 was forced to look for new spheres of activity. This was compounded by the fact that he and his wife were in the process of adjusting to a life without children in the house. In these circumstances, he began to reflect on his past. The interview took place at a time when he was as old as his father had been when Michael had broken off contact with him 30 years earlier. He was unsettled by the question of whether through his own life he was exemplifying a kind of behaviour to his children that they might adopt. He had a fantasy of being left by them the way that he had left his father. Michael considered whether, from a position of being the stronger one, he should make contact with his father and decided to write to him.

A few months later, we were able to conduct a family interview with Michael, his son Alexander<sup>157</sup> and his father Herbert.<sup>158</sup> In response to the interviewers' first question about what had happened for each of the interviewees since the first individual interview, all three men spoke at length about personal biographical changes, without responding to the answers given by the others. None of them mentioned the reunion of father and son after 30 years silence. This theme was only raised through a question asked by the interviewers.

In the following part of the interview, Herbert Liebig expressed his feelings of guilt about having failed as a father, while Michael accused his father of having *"failed politically"*. In response to this, Herbert Liebig said he had always been against the Nazis. His grandson, Alexander, then nineteen, followed this conversation with keen interest and intervened to keep the peace.

---

157 Revital Ludewig-Kedmi interviewed Alexander Liebig in two individual interviews in 1993.

158 The family interview took place in 1994 and was conducted by Gabriele Rosenthal and Bettina Völter.

He asked his grandfather to tell him about *"how he fought in the army just normally like anybody else."* He said he only knew the stories of the members of the Resistance in the family.

Herbert Liebig went into a long-winded narrative about the time he spent in the reserves and as a prisoner of war. He only mentioned the period when he was stationed at the front in a few sentences. He summed up as follows: *"I had a relatively good time in the army and in the POW camp I had a rotten time at first."*

In describing his life in the POW camp, Herbert uses an expression that all of the others taking part in the interview take exact note of. Herbert explains: *"Everyday there were two or three roll calls. We always had to line up and they counted, counted us to death-by-gassing [Vergasung]<sup>159</sup>(1)."*

We interviewers, Michael, and Alexander exchanged awkward looks. Herbert was confused for a moment, but then continued his story unabated. In the following part of the interview, neither Michael nor Alexander took the opportunity to start a dialogue with the grandfather about his choice of words and presentation. When the interviewers asked the grandson what impression his grandfather's story had made on him, Michael Liebig stepped in and said that his son would have preferred it to have been *"more political"*. Alexander rejected this assumption, which he characterized as being *"typical"* of his father. He expressed the hope of hearing more about his grandfather's *"feelings"* during his daily life in the army another time. Michael yielded, stressing how important it was to him to enter into a dialogue with his father, particularly for his children's sake. He said that as far as he himself was concerned, he was somewhat afraid *"that the things I remember will get completely blurred by too much talking or a new interpretation."*

Michael and Dorothee's eldest daughter, the granddaughter Sandra (born in 1972) was spending a semester abroad in Brussels in early 1994 and so was unable to take part in the family interview. During the individual interview that we were able to conduct with her in early 1993, shortly after the first meeting between Michael and Herbert Liebig, she only knew her grandfather Herbert from her father's descriptions.<sup>160</sup> How does this granddaughter present her family history and her own life history?

---

159 The German expression "bis zur Vergasung", meaning "to do something to death (-by-gassing)" came out of World War I and derives from the context of the poison gas attacks, but is generally associated with the Holocaust.

160 Bettina Völter and Revital Ludewig-Kedmi interviewed Sandra Liebig in 1993.

*The granddaughter Sandra: "model story" instead of "victim identity"*

In response to the first question about her family history, Sandra gave a lengthy portrayal of the tensions between her grandparents' generation and her parents' generation and a description of a disintegrating family<sup>161</sup>: *"The grandparents didn't play a decisive role in the family because the parents kept them out. Our real family life went on between my parents, my brother and me."*

It emerges in all passages of the interview how much Sandra would sometimes have liked to have been part of a big family. However, she makes a big effort to portray the distance to her grandparents and other relatives as *"not particularly tragic"*. Sandra initially has a lot of trouble telling a coherent family story. It is only in response to specific questions asked by the interviewers about each of her four grandparents individually, that she can tell us what she experienced with them and what she knows about their lives.

In presenting her own life story, Sandra focuses on the period after 1989. The twenty-one-year-old tells us what she describes as a *"model story"*, a success story about her studies and her career. She is one of those East German young people who were able to use the changes in 1989 very much to their own advantage in terms of their professional biography. However, the façade of what at first seems to be a serene self-presentation appears to hide elements of a construction that is still missing. It emerges in the interview that, among other things, this has to do with her questions regarding her self-comprehension as the descendant of a family with a Jewish background. Sandra explains how proud she is to have such an *"exotic"* Jewish family history. But she says she does not feel Jewish herself. She does say, though, that she has noticed how sensitively she reacts to anti-Semitic comments and jokes. After all, her mother Dorothee taught her to reject any kind of discrimination against minorities. Sandra refers to J.P. Sartre, saying:

*"You can't decide if you're Jewish or not Jewish. Other people let you know that alright. ... I'm convinced that a situation may arise again when it will be important to take action. ... Although I think that when it does you won't even have to speak out as a Jew and say I'm not in favour of that, but I think you can speak out of the whole humanist comprehension and say: no, I'm against that."*

It is striking that, like her maternal grandparents and her mother, Sandra sees Jewishness primarily as an imposed stigma. It becomes apparent how threatening it seems to be for her to look more closely at her family's history of

---

161 We find that bonding and exclusion coexist in disintegrating families (Wirsching/Stierlin 1982, p. 142).

persecution when she talks about her maternal great-grandfather in response to a question. She explains that until now she has given the "*Auschwitz theme*" "*a wide berth*" because she did not want to have a "*victim identity*":

*"It's hard for me to imagine that my family landed in gas chambers ... I'm afraid that you put yourself in this isolation of experience, you sit there with experiences that no one can reconstruct, and that afterwards it'll somehow make me develop some kind of anger or hatred ... I want to master this theme rationally."*

Sandra cannot tell the story of her grandmother Hilde Kaufmann, a story defined by exactly this kind of "*isolation of experience*". She presents Hilde as the daughter of an opponent of the regime, who "*might possibly have*" had problems as a result. But Sandra says that Hilde was "*not attacked*" for being Jewish. Sandra asks the interviewers whether her grandmother survived in hiding perhaps, and then says: "*That's always a real gap, I'll have to ask her about that directly.*"

In the following part of the interview it emerges that years ago, the biographer's grandmother showed her the prison where her grandmother's father was incarcerated for years. But she says that as an adolescent, she found this story "*not so interesting*". Sandra had introduced her grandmother Hilde as her grandfather Martin's "*appendage*" and in response to a question then describes him as a "*hero*". She remembers particularly vividly a trip she made with her grandfather to the place in Belgium where he was liberated by the partisans. Sandra says she is "*fascinated*" by the thought that her grandfather could have been shot: "*if he'd have died, then I'd never have been born.*" She says that while her grandfather told her part of the story of his involvement in the Resistance directly, she noticed that he did not talk about his feelings in connection with it.

Like her grandfather Martin and her mother Dorothee, Sandra also focuses on the story of this part of Martin's history and does not mention his experiences of persecution. She regrets that Martin remains silent about his experiences during the 50s. Sandra describes the dialogue between her mother Dorothee and her mother's father Martin Kaufmann as blocked in much the same way "*as children who ask their parents about the SS.*" She mentions that her grandfather has admitted to having worked for the "*Stasi*" and speaks of books and documents that prove that he was involved in "*one of the trials against Jews*".

She says that she wonders whether Martin was a witness for the prosecution or whether he was the accused. Sandra herself has a definite fantasy that her grandfather was blackmailed and gave evidence against a comrade from the Resistance so as not to end up in "*Siberia*" as a suspicious emigrant from the West. She also wonders whether, when he was a member of the Resistance in the *Wehrmacht* headquarters, he acquired information which he is

still not at liberty to speak of today. Sandra says that Martin would have *"done anything for Socialism, including bumping off his own mother"*.

As a member of the third generation, Sandra has very definite fantasies about her grandfather's history. These fantasies mainly concern phases of his life history in which it is unclear whether and to what extent he was forced to collaborate with the perpetrators to protect himself or whether and to what extent he sought collaboration to fulfil his anti-fascist mission. Despite these incriminatory fantasies, the history of her grandfather as a hero story remains positively cathected and dominates her presentation of the family history. In her own biographical decisions, she orients herself very much on her grandfather, as her decision to spend her study period abroad in Belgium suggests. On the other hand, she avoids the idea that her maternal grandparents were persecuted under National Socialism. She is afraid of not being able to share her feelings with anyone and presumably also fears having her biographical project disrupted.

Sandra finds the history of her grandparents on her mother's side *"considerably more interesting"* than the history of her grandparents on her father's side. She says that although she felt more warmth from her grandmother Elisabeth, she did not return it. Sandra explains: *"She was just always on the losers' side. Somehow I don't find that interesting. I'm more interested in the winners and not so much in the losers."*

This pattern of a polarized representation is found in many narrative passages in the interview. It can be interpreted as an expression of the dividedness of this family. Sandra portrays her grandmother Elisabeth as a victim of the war. She says she suffered through the air raids, had to cope with daily life in the war on her own and lost her husband after the war. She says the years between 1936 and 1938 were the best of her life. Sandra does not consciously relate the very different histories of her two grandmothers, who were roughly the same age and both lived in Germany under National Socialism. She is astounded and fascinated by the perspective of her grandmother Elisabeth, who *"lived just like normal"* in the Nazi period, whereas she herself imagines this period as a *"permanent hell"*. Sandra says that one can tell from her grandmother's anti-Semitic and racist comments how little she has thought about the past. Her grandmother's naive openness creates an intellectual distance to her granddaughter, but it also attracts her. *"It comes out much more purely that way, not transfigured by a background in history, but rather very tangible."*

Like her brother Alexander, Sandra sometimes wished that she had had another family history than the story of the heroes of the Resistance: *"Sometimes I wished that my father, my grandfather had been some kind of SS general. You could have squeezed something out of him then. Everything is so incredibly alright in our family."*

As a young adolescent, she really wanted to get to know her grandfather Herbert, especially as she was said to be physical like him. Her father Michael advised her to go ahead. But then she decided to demonstrate solidarity with Michael, who at that time rejected any contact with Herbert. Thus, Sandra only knows this grandfather through stories. In the interview, she describes him as an *"authoritarian, mean, hard, Aryan guy"*, who as a former Nazi and Stalinist fled from the West to East Germany. She says that he *"constantly beat"* Michael when he was a child and was *"never interested in him"*. Sandra believes that her grandfather was not a soldier, but rather worked in his occupation as a technician in Russia from 1941 on *"just as a thinking agent in the background"*: *"That was probably considerably more agreeable to me than imagining him with a machine gun."*

By assuming that her grandfather Herbert worked as a technician in Russia, the granddaughter evades another threatening idea as well. If she were to imagine her paternal grandfather as a soldier during the Ardennes offensive on the Western front, she would presumably realize that he had been in geographical proximity to her grandfather Martin. Both grandfathers could potentially have met face to face as enemies. Sandra avoids this image and only imagines her grandfather Herbert in France as a prisoner of war who had to do *"forced labour"*.

Her grandparents' different paths through life under National Socialism, which in some phases appear to be opposing histories, burden the generation of the grandchildren in this family with the dilemma of dealing with a divided family past. The exclusion of the grandparents' generation from her family makes it possible for Sandra not to relate her grandparents' histories to one another. On the whole, the case study shows how difficult this member of the grandchildren's generation finds it to overcome her parents' disassociations from the grandparents' generation, and to build up an emotional relationship to her grandparents. Also, the family history appears to Sandra to be somewhat atomized, to disintegrate into individual components rather than forming a narratable whole. As in her grandparents' and parents' generations, the history of the grandfather's involvement in the Resistance is the part that the granddaughter emphasizes and identifies with positively. In contrast, she avoids remembering the persecution experienced by her grandparents and her great-grandfathers. She is afraid of not being able to share her experiences and her feelings with anyone if she makes the history of the victims part of her biography.

### Concluding Remarks

As in the Basler family discussed earlier, the memory of individual family members' involvement in the anti-fascist Resistance also dominates in the Kaufmann/Liebig family. The persecution experienced by the grandparents'



generation tends to disappear from family memory: this allows all three generations to look at the past under cover of the East German collective discourse, which made active opposition to the Nazi reign of terror the core component of its memory. In contrast, the experiences, fears and guilt feelings bound up with the history of persecution were kept silent or were addressed as a theme in the sense of the individual problem of those affected. Later generations are unable to tell specific stories about experiences of persecution passed on this way. Rather, these experiences are present in the form of diffuse fears that tend to prevent the second and third generations from consciously dealing with this part of their family history.

In the Kaufmann/Liebig family, the *"break between the generations"* in a political light is a further structural criterion of the family system. This family dynamic has its roots in the respective family pasts. We already see signs of a divided family in the history of the two pairs of grandparents: the Kaufmann grandparents, who were persecuted under National Socialism as *"Mischlinge"*, experienced the division of their family - primarily imposed from outside - into those who were persecuted, those who were not persecuted and those who fought in the Resistance. In the post-war period, they undertook a further separation from their families of origin by moving to East Berlin. The Liebig grandparents, who were among the sympathizers of the Nazi regime, got divorced after moving to East Germany. In both families, family dynamic conflicts often went hand in hand with political conflicts. Despite all of the obvious differences in the experiential histories of the grandparents' generation, further similarities emerge in the structural depths: the grandparents' biographical decision to leave the period of National Socialism behind them and start all over again by moving to a *"better Germany"* implies, as we have seen, a price for the family dynamics, in addition to all of its positive effects.

The family experiential history under National Socialism, but also the efforts made to conform to East Germany society resulted in taboos being created around specific parts of the family history. The family history directly after the war in particular remains obscure for later generations. These question marks create sources of friction for the generation of the children. Both members of this generation share a scepticism and criticism of the Socialist ideals and values of their parents. Both try with the help of the perspective of the other partner to loosen their ties to their family of origin. Unlike in the Basler family discussed above, the differing worlds of experience of the grandparents' generation in this family do not merge into a harmonizing version of the family history. Where the Basler family makes a taboo of the history of the non-Jewish part of the family and looks for common ground in an identification with the Socialist state of the present, Kaufmann/Liebig family members address the theme of political and family history differences. However, the generation of the grandparents in this family are kept at a physical

and emotional distance, so that this family cannot use dialogue to deal with its divided family past either. Whereas in the grandchildren's generation of the Basler family we find a merging of non-Jewish and Jewish family history, the granddaughter of the Kaufmann/Liebig family develops a polarized and atomized image of the family. This helps her to avoid having to relate the directly opposing experiential histories of her grandparents.

In contrast to the Basler family, for whom the changes in 1989 led more to a stabilizing of family secrets, the Kaufmann/Liebig family is an example of how the political changes in East Germany were able to promote the opening up of a family dialogue.

Part 5:  
Families of Nazi Perpetrators and  
Accomplices in West and East Germany



## 16. National Socialism and Anti-Semitism in Intergenerational Dialogue

Gabriele Rosenthal

How do the children and grandchildren of grandparents, who identified with National Socialism or were actually implicated in the Nazi crimes themselves, live with this part of their family history? What do they know and above all, what fantasies do they have about their family's past? Pursuing these questions requires an understanding of how the grandparents talk about their Nazi past. The following will look first at a discussion of the differing biographical strategies that the generation of the grandparents use to try to repair their dubious and incriminating past, and in turn at the strategies the generation of their children and grandchildren use to exonerate themselves from their problematic Nazi family past. This will be followed by a presentation of two families with a National Socialist past.

### Blocking out Nazi crimes and dehumanizing the victims

There has been increased media coverage in Germany of the Nazi crimes for many years now, but the perpetrators and collaborators of the Nazi period continue to wrap themselves in silence or, through detailed stories of the painful experiences they went through during the war and in the post-war period, to portray themselves as innocent "witnesses" without actually giving a witness testimony (Rosenthal 1993a). It is only in recent years that some sons and daughters of Nazi perpetrators have begun to speak about their parents, about the way they suffer because of them and about the collective silence that weighs on them so heavily<sup>162</sup>. The analyses, that I have conducted myself over the past fourteen years of the way the grandparents' generation deals with the Nazi past (Rosenthal 1990, 1992a, 1993a), show very clearly how successfully - in some cases without any conscious intention - they can present their past as unincriminated. Using differing narrative strategies, depending on which generation they belong to<sup>163</sup>, they censor all of the incriminating

---

162 Journalistic works on the theme of children of Nazi perpetrators by Peter Sichrovsky and Dörte von Westerhagen, respectively, appeared in 1987. In the same year, Niklas Frank published his "reckoning" with his father. And in 1989, a social science study by Israeli psychologist Dan Bar-On came out as well.

163 For details of the concept of generation and generational succession in families, cf. Rosen-

events linked to National Socialism in their life story. By detaching their own life story from the political framework of National Socialism and thus glossing over their experiences connected with systematic persecution and annihilation, they present themselves as people who were not involved in the collective events, people who, through World War II and its consequences - such as flight and expulsion -, became victims of National Socialism. In these life stories, this repair strategy, that we have termed "blocking out", fulfils the function of denying experiences that are embarrassing, guilt-ridden or have collectively been made taboo. In addition to being an attempt to join the "collective of victims" and to set off what they suffered against the suffering of the victims of the Nazi regime, these life stories also constitute an avoidance of addressing the theme of crimes against humanity. Speaking in general terms, we can therefore assume that the generations that followed were more often than not socialized in family milieus where the family's past before 1945 is to a great extent shrouded in mystery or where the myth is cultivated of a family past not implicated in Nazism.

The touchy parts of the family history are often so elaborately blacked out and passed over that they can only be detected by listeners with the appropriate emotional openness, experience and historical knowledge. However, even when such intimations and hints are quite clear, there is very little risk of further exposure in inter- and intragenerational dialogue in Germany, as intimations of involvement in Nazi crimes are often passed over or blocked out by the listeners because of their own fears. That we ourselves as non-Jewish German interviewers are not free from this is something my colleagues and I experience time and again, even though in our conscious judgement we are so interested in exposing implications of this kind (cf. Rosenthal 1990, p. 216ff.). We, too, are members of the children's and grandchildren's' generation and have vague fears about exposing the past of people we encounter who despite their pleasant personalities may have done terrible things. We were socialized in our families and in German daily life in milieus where taboos about addressing certain themes, prohibitions against asking further questions and certain exonerating depictions were and continue to be operative.

The glossing over of Nazi crimes in ones own life story and the family history goes hand in hand with the exclusion from the family "historiography" of the victims of the Nazi system, who neither feature as individuals nor as a collective. This glossing over has its analogy in academic historiography where research is either done into National Socialism and World War II or into the Shoah. Here, too, Nazi persecution policies are not a self-evident part of the historiography of National Socialism, but rather a special discipline. According to my analyses (Rosenthal 1992b), the glossing over of Nazi

---

thal 1994.

crimes and with it the failure to address the theme of the victims - particularly the Jews -, that emerges so clearly in these present-day life stories, builds on a process that set in at the beginning of the Nazi period in the life histories of these non-Jewish Germans<sup>164</sup>. The disappearance of the Jews from their perception and consciousness, their silence surrounding the persecution of the Jews and with it their defence against memories of things connected to this persecution began long before the annihilation of the Jewish population. Before the German Jews were put on "transports" from 1941 onwards, they were already so dehumanized that one can speak of a psychological murder even before they were sent to the death camps. The process of the derealisation (cf. Dahmer 1990) and dehumanization of the victims occurred very gradually and was hardly noticeable for the "witnesses". It took place in phases that can be broken down into time units and that correspond to the state policy of disenfranchisement and annihilation<sup>165</sup>:

1. The phase between 1933-1935 was characterized by less and less contact between Jews and non-Jews and corresponded to a stepping-up of state-decreed measures of persecution.

2. The phase between 1935-1938 commenced with the Nuremberg Laws and the decrees connected to them and ended with the November pogrom of 1938. During this phase, the exclusion and avoidance of Jews became so extreme that in 1938, German non-Jews only registered the damage that was done to property.

3. In the phase between 1938-1945, the intensified persecution of the Jewish population and the mass transports led to the Jews becoming completely dehumanized and disappearing from the perception of non-Jews until they forced their way back into it towards the end of the war, as soulless concentration camp inmates.

4. After the "Third Reich", the socially-imposed acknowledgement of the annihilation corresponded to a projection of the guilt feelings of non-Jews on to Jews. From creatures without an identity, they were now made into guilty Jews.

These phases are very clearly manifest in life stories told in the present day. While in accounts of the early years of the "Third Reich" Jews still emerge as a theme and are introduced into the interview as people with identities, or at least with professions, perhaps even a name, later they disappear more and more from non-Jewish life stories.

While the anti-Jewish campaigns from 1933 onwards are hardly mentioned, the theme of Nazi persecution reappears in connection with the so-called *Reichskristallnacht* and is virtually reduced down to this one event. However, in the narrated accounts of this event, Jews generally do not even

---

164 For details of the difference or dialectical relationship between life history and life story, cf. Rosenthal 1995.

165 For details of state measures taken against the Jewish population, cf. Hofer 1985.

feature as people, but rather - in accordance with the linguistic prescription of the *Reich* night in which "crystal glass", as a symbol of the wealth of the rich Jews, was smashed - the damage to property is described, the pieces of glass and the burning synagogues. The humiliated, beaten and arrested people are barely mentioned, and neither are the perpetrators.

After the account of the November pogrom, Jews as active agents disappear from the life stories of non-Jews. This process is manifest in terse statements made in the present day, like: "and then suddenly they were gone". This indirect way of speaking about "them" in the third person is also typical. The dehumanization of the victims is reflected here linguistically, too; they are not only identityless and nameless as individuals but also as a collective.

The dehumanization of the victims, which is linked to a silence surrounding all of the experiences connected to the persecution, is thus transmitted to the next generations latently and in intimations only. As a result, we can also find a failure to address the theme of the victims in the generation of the children and grandchildren, although without the latter having access to what is being kept silent. As our interviews show very clearly, the dehumanization of the Jews comes to the fore in a fairly unveiled way in the grandparents' generation in statements like: "*The business with the Jews didn't really concern me*", whereas in the generation of the children and grandchildren, it is sometimes manifest in the complete avoidance of the theme of "Jews"<sup>166</sup>. The Jews become a virtual taboo. Not only do these generations not speak of them, they literally avoid uttering the word Jew. Without any conscious intention, this strategy of avoiding the theme of the Jews in connection with the Shoah carries on something that began in the Nazi period: the Jews remain dehumanized creatures without names or identities.

By not talking about the theme of Jews and Shoah, one is not exposing oneself to the risk of being unmasked as an anti-Semite. However, by not doing so, one is denying oneself the opportunity of becoming aware of one's own anti-Semitic tendencies and lack of informedness through dialogue. And those who sense the latent anti-Semitism of the people they are speaking with, and suffer as a result of it, shy away from a confrontation and all too often doubt their own perception and feelings.

### Blaming the genocide on the Jews, and the perpetrator-victim inversion

Apart from glossing over their own implication in National Socialism and generally failing to address the theme of the genocide, a further strategy found in all three generations is that of blaming the genocide on the Jews, one that can be reduced to thoughts and expressions like: "the Jew's got only himself

---

166 The analyses of Bergmann and Erb from 1991 show a close connection between aversion to communication and anti-Semitism ( $r=0.47$ ,  $p < .001$ ).



to blame". In order not to have to face up to the question of ones own or ones family's guilt and implication, one prefers to occupy oneself with the guilt of others. If one avoids speaking about Jews for the reasons named above, this still leaves the possibility of occupying oneself with the guilt of the victorious powers and in the process, references are made all too often to the Jewish officers among the Western Allies and in the Soviet army.

A secondary anti-Semitism can then develop as a defence against self-accusation and the guilt feelings linked with it, not only in the form of a failure to address the theme of the Jews but also in a very manifest way. Aggressions arise against the victims, whom one cannot forgive for the guilt they have inflicted on one (cf. Jokl 1961), or against all of those who remind one of the Nazi crimes. These aggressions are not directed at the former perpetrators or at the lack of candour that still prevails today, but far more against those who talk about the crimes and could name the perpetrators.

A contrastive comparison of life stories and family histories indicates that the deeper family members of the first generation are implicated in Nazi crimes, the more directly and openly they try to exonerate themselves using this strategy of assigning the guilt to the Jews. Women and men, who were involved in the persecution and mass murder, hide their anti-Semitism far less than others. Blaming the Jews serves them in a very direct way to justify their actions. The extent to which this is an "anti-Semitism because of Auschwitz" (cf. Bergmann 1990) generally emerges in a bizarre way. For example, Mr. Seewald (cf. 5.2), who lived in East Germany and whose interview suggests an implication in the crimes, advocates explanations that he backs up by using aspects of Marxist historiography. He blames the genocide on big international capitalists, whom he claims are mostly Jews and for whom Hitler was just a puppet.

A further example is provided for us by Mr. Acka<sup>167</sup>, who, as part of a small mobile killing unit, was implicated in the systematic annihilation of the Jews in Transnistria. Referring to the Jews in Transnistria, he says: *"And of course epidemics came and many, many people die- many Jews died there. We never burned them, they went and killed themselves there 'cause they had nothing to eat"*.

The mass murder is depicted here as if it had been carried out by the Jews themselves. The narrator had to break off the phrase *"many people die-"* and correct himself, because it was not *"people"* who died, but *"Jews"*.

If incriminated "witnesses" or Nazi perpetrators talk this way relatively openly, less incriminated "witnesses" usually only voice thoughts like "the Jew's only got himself to blame" after hours of interviewing or only in indirect intimations. Voicing such thoughts, often held back with a great deal of energy, takes time and above all an interviewing technique that helps the bi-

---

167 Cf. the detailed case description in Rosenthal 1990, p. 193-215.

ographers get caught up in the narrative current of their story and thus orient themselves less on the interviewer. Only when, as interviewers, we create this narrative space, above all do not shy away from anti-Semitism or implication in the crimes becoming manifest and ask questions at the appropriate places, does it become possible to reconstruct latent anti-Semitic attitudes as well as the overtly-expressed type of anti-Semitism. This assigning of guilt to the Jews is often expressed indirectly in rhetorical questions like: "*Time and again I wonder what it is about the Jews that they've been persecuted for centuries?*". The channelling of anti-Semitism into anti-Zionism - a form commonly found in the children's and grandchildren's generation -, expressed in the view that the Israeli policy of occupation shows that the victims have become guilty perpetrators, serves the projection of their own vague guilt feelings on to the victims<sup>168</sup>. In general, all three generations of non-Jewish Germans demonstrate a tendency of preferring to occupy themselves with the past and present guilt of the victims or with the Allies and their own suffering during the war and the post-war period than with the guilt of the Nazi perpetrators, especially if members of their own family fall into this group.

While survivors of the Shoah are tormented nearly every day by memories of scenes, in which men from German units like the SS or the *Wehrmacht* cut Orthodox Jews' beards off, beat infants to death, locked people in buildings and set them on fire or set dogs on pregnant women to tear them to pieces, their persecutors and the children of their persecutors talk about how they suffered as a result of their experiences of the war and the inhumane treatment they were subjected to in the POW camps.

Just as in their remembrance and in their stories, so-called witnesses of the persecution gloss over the scenes that they lived through of brutality towards Jews and other persecuted people, so their descendants' knowledge of the actual process of persecution generally remains abstract. In their thinking, the descendants tend to focus on the murder in the gas chambers, which is made anonymous, and less on the brutality inflicted in face-to-face encounters between perpetrators and victims in the ghettos, during operations, during on-site massacres and during mass shootings<sup>169</sup>.

Although the myth of compulsion to obey orders is still cultivated in the collective German remembrance and non-Jewish Germans assure one another

---

168 For more on the mechanism of shifting guilt to the victims, see Jokl's case analysis of 1961.

169 Browning's 1993 study of a police battalion is one of the few that reconstruct in detail, based on witness statements, the process of annihilation in the Soviet Union and in Poland. The massacres described show clearly that, contrary to the notion of the anonymous killing of a row of people with their backs turned who were designated to be killed, the perpetrators selected their individual victims or were assigned them and in some cases even had conversations with them before they murdered them by shooting them in the back of the neck (p. 86ff).

in both inter- and intragenerational dialogue that the perpetrators and collaborators were forced to do what they did, some of them are still capable of accusing the victims of not putting up enough resistance. This variation of shifting the blame on to the victims by accusing the Jews, who supposedly allowed themselves to be led like "lambs to the slaughter", of passivity, especially emerges in the interviews that we conducted in former East Germany. Phrases like: "*Only active people counted in East Germany*" are heard here. In the official East German remembrance, Jews - such as the Jewish child Stefan-Jerzy Zweig in the Buchenwald concentration camp<sup>170</sup> - appear, at best, within the scope of the glorified political resistance in the role of people saved by Communists, or as "anti-fascists". Exoneration through in-depth tales of the inhumane way German soldiers were treated in Russian POW camps or through accusing "the Russians" of crimes committed by the German *Wehrmacht* is not only something West Germans tend to indulge in. As our presentation of the East German Seewald family will show (cf. 5.2), the entire family here focuses on the construction of a family history as victims of the Russians or the Soviet occupying force. The daughter very clearly demonstrates the repair strategy of a "perpetrator-victim inversion" which makes victims of the perpetrators (cf. 6.2). Like her mother, the granddaughter undertakes a temporal shift of her grandfather's experiences by presenting his experiences in the Soviet Union during the war as if they had taken place during the time he spent as a prisoner of war. By speaking of her grandfather almost exclusively as a prisoner of war, she presents him as a victim and glosses over the period when he was active as a soldier or a member of another unit.

### Pseudo-identification with the victims

Apart from not addressing the theme of the victims and blaming the Jews, there is yet another way that the second and third generations deal with the Shoah and the implication of their own family in National Socialism, one which on the surface seems very different from the other two. This type of avoidance tendency can become manifest when non-Jews get more closely involved with the theme of Jews and Judaism. The anti-Semitism, that expresses itself as philo-Semitism discussed by Frank Stern (1991), can - as our case analyses indicate - also be acted out through marriage to a Jewish partner<sup>171</sup>. The extent, to which even converting to Judaism can serve to totally

---

170 Cf. the brochure on the memorial (Dietz-Verlag publishing house, no year specified) or Buchenwald 1988. A similar example is a film shot by Konrad Wolf in 1959, an East German-Bulgarian co-production. In it, a German soldier allied to a Bulgarian partisan group falls in love with a Jewish woman and tries in vain to save her from being deported to Auschwitz. The partisan group supports him in his efforts.

171 For more on couple relationships between Jews and non-Jewish Germans, see Kurt

avoid confronting ones family past, is illustrated by Dan Bar-On (1993b) through the case of a Rabbi in Jerusalem, the son of an SS man, who has completely broken off contact to his family in Germany and who avoids knowing any more about his father's past. Eva Kovacs and Julia Vajda (1994) observed a very similar mechanism when they interviewed the non-Jewish parents of students at a Jewish school in Budapest. In one case study, they show how a man uses his daughter to atone for her father's Nazi crimes and how he avoids thinking about his family past by gaining entry into a Jewish milieu. The interviews, that we have conducted thus far with members of the second generation of non-Jews who have married a Jewish man or woman, also show the extent to which these marriages can serve avoidance tendencies (cf. Achim Svoboda, 2.2.). Thus, a strategy of *pseudo-identification with the victims* can be used to avoid taking on the perspective of the victims and confronting the perpetrators. By putting ones own suffering on a parallel with the suffering of the Nazi victims and identifying with them, one can avoid confronting the perpetrator aspects of ones family past on the one hand and protect oneself from empathizing and taking on the perspective of the victims of Nazi persecution on the other (Rosenthal/Bar-On 1992). If one then gains entry into a Jewish partial milieu through marriage, one can give oneself the image of someone who is above every suspicion of being anti-Semitic.

#### Two families living with the suspicion of the perpetration of Nazi crimes

For the following detailed representation, we chose a West German and an East German family from the group of non-Jewish families that we interviewed. In both the Sonntag family and the Seewald family, a suspicion pervades that the grandfather perpetrated Nazi crimes. In the way they deal with the past, the members of both families very clearly employ strategies of concealing, of assigning guilt to others and of the construction of a victim family biography. The psychological consequences, that a defence against acknowledging the family past can have for the descendants, emerges in both families. Their defence against exposing the family history by no means leads to them being able to separate from their family past; rather it binds the children and grandchildren to the problematic aspects of the family history and therefore blocks the process of separating from their family and becoming autonomous. The mechanisms of concealing the Nazi past operative in the Sonntag and Seewald families and the difficulties, that arise from it for the children and grandchildren, are typical of families of perpetrators. These families illustrate the extent to which work of mourning - as a consequence of the dehumanization of the victims, the acceptance of persecution under National Socialism or implication in the crimes - not done by the grandparents can lead to the chil-

---

Grünberg's study (1991).

dren and grandchildren having to struggle with the very fears - like fear of the crimes being exposed or fear of the revenge of the victims - and guilt feelings that the first generation have avoided. As in other families we interviewed, it is not only the grandparents here who block opportunities for a more open dialogue by making contradictory statements, refusing to discuss certain issues, breaking off discussions they do embark on and telling implausible stories. Their children and grandchildren are also interactively involved in blocking out the family past. While in families of prominent Nazis, or in families where public legal proceedings were initiated against the parents or grandparents, the children and grandchildren either have to face up to the known facts or else deny them or avoid addressing the theme, these families are typical of all families where no concrete facts about the past are passed on, but rather merely intimations and hints.

In both families, the grandmothers have a decisive influence on the grandfathers not revealing their Nazi past. There are also indications that both grandmothers may have been implicated in National Socialist persecution policies themselves. In our opinion, further empirical analysis is needed of the role of women in the "Third *Reich's*" annihilation policy, in the Nazi careers of their husbands and in the post-1945 policy of concealment within the family (cf. Grote / Rosenthal 1992). Research to date has confined itself far too much to the role of men as perpetrators and for a long time, women were primarily seen in the role of the victims of these perpetrators<sup>172</sup>. This view corresponds to public and family dialogue on National Socialism. If children and grandchildren do turn their attention to the theme of a possible perpetration of crimes in their family, it is generally fathers or grandfathers who are under suspicion. They only rarely entertain a suspicion of the possible active participation of grandmothers in the persecution and annihilation policy.

In both families, a religious interpretation of the family history also plays a role in their exonerating themselves of their own responsibility. Their own life history or the family history are interpreted as "divine will". Institutions of the Protestant Church such as the "Home Mission"<sup>173</sup> help the Sonntag grandmother to find continuity to her life in the Nazi national community and its institutions. However, the two families also differ from one another in a number of key points: during the Nazi period, the Sonntag grandfather was in the position of giving orders and the Seewald grandfather was in the position of receiving orders. Furthermore, after 1945, the two families were socialized

---

172 Women's studies publications on the theme of National Socialism are increasingly abandoning this interpretation. If discussion initially focused on the complicity of non-Jewish women (Thürmer-Rohr 1983) in the sense of their active collaboration in maintaining patriarchal power structures (Windaus-Walser 1988; 1990), studies have now been done on women as perpetrators of Nazi crimes (cf. Eppinghaus 1987).

173 Institutions and establishments of nondenominational Christian welfare activities: Christian social work in communities and institutes.

in different German states. Nonetheless, a comparison of these families shows that, while the fact that they lived in two different German societies after 1945 had an influence on the content of their interpretations of the past, the way they repair the past and the impact of the past on the descendants do not differ from one another in their deep structure.

To avoid the family past, the son of the Sonntag family uses repair strategies that we have already reconstructed as very widespread strategies in the generation of the collaborators and perpetrators. He tries to pass the blame on to the victims. His sister suffers from sleeping disorders, depressions and very striking gaps in her memory. Both children torment themselves with fantasies about their own perpetrator traits and develop tendencies towards self-punishment. In the process, the son pursues the question of whether he himself would have been able to give orders to commit acts of annihilation.

The daughter and granddaughter of the Seewald family are among those descendants who try to reinterpret the family history as a victim story. The daughter reproaches herself here with not refusing to obey orders to learn to shoot during her military training in East Germany.

The fantasies of disobeying orders or giving orders correspond in both of these families to their specific family past. In other words: the differing fantasies and symptoms (fear of fire and fear of drowning), that we find in the two families, correspond to their family pasts and are far less determined by their post-1945 socialization in two different social systems. As our analyses of both families of perpetrators and of victims show clearly, the fantasies about the past, that the children's and grandchildren's generation develop, correspond in form and content in a striking way to the specific experiences of the grandparents' generation. And the chance to confront a psychologically incriminated family past lies precisely in this development of symptoms. This is why the life stories of the grandson of the Sonntag family and the granddaughter of the Seewald family are far less oppressive than those of grandsons and granddaughters who remain at the same stage as their parents, avoiding a clarification of the family past by using strategies of not addressing the theme, blaming the victims or pseudo-identifying with the victims<sup>174</sup>. The life stories of the grandson of the Sonntag family and the granddaughter of the Seewald family are typical of the third generation, who in contrast to their parents are beginning much more to act out symptoms that correspond to the family's Nazi past and by doing so are beginning to expose and confront this past.

---

174 Cf. in this context the case study of the Szanda family, Rosenthal 1944.

## 17. Passing the guilt on to the grandchildren: The Sonntag family

Gabriele Rosenthal in cooperation with Christine Müller

### *Imprisonment for crimes against humanity*

In the Sonntag family, we interviewed both grandparents, Otto and Frieda Sonntag, their son Eberhard, born in 1940, their daughter Ulrike, born in 1945, and her daughter Silke. We also interviewed Eberhard's wife Maria and their son Uli. Although we went to great lengths to arrange a family interview with the grandparents, the son and the grandson, and although the grandson supported our efforts, the appointments we made ended up being cancelled again and again. Just how threatening a dialogue about the grandfather's past is in this family for all the family members emerges very clearly from the analysis of the individual interviews. However, it also becomes apparent how helpful the opening up of this dialogue can be for the children and grandchildren of this family.

Otto Sonntag's imprisonment in 1946 on charges of crimes against humanity leads both us as interpreters and the children and grandchildren in this family to suspect the grandfather of being implicated in crimes. Our analysis of the interviews increasingly made us ask ourselves questions about whether the grandmother may possibly have been implicated, too, but we were unable to answer these questions.

Otto Sonntag was already a member of a National Socialist organization when he was a young man in the twenties, then he became a member of the SA in 1928, a member of the NSDAP in 1932, and later SA *Führer*. A certified architect, he worked as a government building inspector during the war. His accounts of the nature and locations of his "missions" are imprecise and contradictory. The place references he makes do not tally with those made by his wife, nor with the information we obtained from the archives. In his quite brief presentation of what he did during the war, Mr. Sonntag states that he was in Norway as a construction engineer to build radar installations and then speaks in more detail about being sent into action on the Northern Front near Staraya Russa. He states that he was recommended for promotion, that he had to go into "action at the frontline". Staraya Russa is the only place reference in his entire account of the war<sup>175</sup>. Without mentioning any other time refer-

---

175 During the seizure of the area of Staraya Russa on Lake Ilmen in August 1941, Sonder-

ences, he recounts that he was wounded, that after that he was in hospital on *Reich* territory for a time and that he then returned to Norway. However, according to archive information, Mr. Sonntag initially worked as a government building inspector (promoted in 1942) and from 1944 on as a government building surveyor in the service of the *Luftwaffe* (German Air Force) in the Munich *Luftgaukommando* (District Air Force Commando Unit)<sup>176</sup>. Neither he, nor his wife, nor any other family member mention the time that he spent in the Munich area during the war.

In 1946, Mr. Sonntag was imprisoned for nine months: his accounts of who by alternate between the French occupying forces in Württemberg and the US military authorities in the former concentration camp of Dachau<sup>177</sup>. Most of the inmates imprisoned in Dachau from 1945 to 1948, following various trials brought before the US military court, were charged in connection with crimes committed in concentration camps (cf. Marcuse 1990; Sigel 1992). Otto Sonntag himself says that the charges brought against him were related to the perpetration of crimes in France. He claims that the charges were unjustified in so far as that he only came to France as a prisoner of war. He says that he was able to exonerate himself by showing his military pay book which his wife brought to him after he had been imprisoned for nine months. His account of his release from internment and his rehabilitation are fairly dubious both in terms of content and text structure. We westerners cannot go into the many references in his life story that suggest the perpetration of crimes in any more detail here. What is important for the family history is that, because of his numerous implausible accounts or refusals to make statements, suspicions or questions about his possible perpetration of a crime prey on the minds of his relatives. It requires a considerable amount of energy for them to try to evade these suspicions or questions. We methodically introduce into the interviews the suspicious factors that as interpreters we have gathered from the interview with Mr. Sonntag. We pursue the question of to what extent similar suspicious factors are latently or manifestly expressed in the interviews with the children and the grandchildren.

Let us first examine the context within the interview and the way in which Otto Sonntag himself talks about how he spent the war. He responds to the request to tell his family and life story<sup>178</sup> by telling his life story in great detail

---

kommando (Special Duty Commando) 1b was assigned to the 16th German Army (cf. Krausnick 1985, p. 153ff.). The German Army's Soviet offensive began on this North-western Front on 7 January 1942.

176 The latter promotion occurred in 1944 at a time when few buildings were being commissioned with three exceptions: barracks, storerooms, etc. for the Wehrmacht, barracks for the SS, and extensions to concentration camps.

177 As in his account of his whereabouts during the war, here too considerable contradictions and above all historical inaccuracies appear that we are not at liberty to disclose in detail for reasons of anonymity.

178 Otto Sonntag was interviewed by Gabriele Rosenthal in 1993. He agreed to an interview of



and with a clear structure until he arrives at 1939 (21 pages of the transcript). In the process, Otto Sonntag admits his enthusiasm for National Socialism and his membership in the various Nazi associations. Then he speaks for some time (four pages) on the theme of "The War Guilt of the Jews", and it is only after this that he covers the entire period from 1940 to his release from imprisonment in 1946 in just five pages, very chaotically with numerous interruptions and often springing back and forth in time.

The textual framework of the theme "The War Guilt of the Jews" is of considerable interest. Before Otto Sonntag begins to talk about it, he tells us how he worked for the military building authorities until 1940 within the scope of rearmament doing barrack construction. At this point, he breaks off the linearity of his life story, and we only discover much later that after this he went to the *Luftwaffe* on Reich territory. In other words, instead of talking about what he did after he worked for the military building authorities and about his active participation in certain operations in this phase, he argues that the Jews were guilty. His subsequent presentation of what he did during the war and the time he spent in a POW camp are thus embedded in an allegation that the Jews are to be made responsible for these years.

He begins this sequence about the war guilt of the Jews with the opening statement "*So then came the year 1938, 1939*":

*"I don't want to go into that at all now, THERE WERE REASONS that at that time the Jews were- especially in Berlin, you should read the history of what kind of role the Jews played in Berlin, 'it was a bit of a dirty business'. ...That was- and now we come to the point I want to make in passing, that this- this unmastered problem of the Jews (2) actually (2) led to the World War ((pointedly)). It sounds strange, but that's how it is. Because through the war, international Jewry, who were high up everywhere- especially in America and still are today, they naturally said then: we're not going to let ourselves be treated this way as Jews in Germany, something has to happen here."*

The extent, to which these attributions of guilt are a ploy to avoid giving an account of his own actions during the war, emerges again in the questioning part of the interview. When asked again to tell us how he experienced the beginning of the war, Mr. Sonntag replies: "*I keep telling you, that was nothing else but the retaliation of international Jewry, who said now we've got them and now there'll be no letting up.*"

Apart from blaming "international Jewry" for the war, Mr. Sonntag uses a second pattern in much more detail to exonerate himself - one which presumably seems "less dangerous" to him when talking to the interviewer - in the context of his account of the time he spent in a POW camp and his subse-

---

nearly three hours in length, and refused to take part in a second one.

quent arrest and imprisonment on charges of crimes against humanity. He accuses the Allied judicial system, with its *"inhumane"* proceedings, of being unjust and refers to the execution of many innocent men. He expresses indignation at the fact that survivors of the former Dachau concentration camp were brought before the detainees to identify them, as in his view they were *"mostly criminals"*. In contrast, he hardly addresses the theme of the guilt of the accused Nazi criminals, but rather boasts about what high-ranking Nazis he was imprisoned with. He only speaks of the crimes against humanity when asked about them by the interviewer. He claims to have only found out about them during his imprisonment in Dachau. What is striking and of importance for the further analysis of the family history is that he confines himself to the theme of "piles of corpses" and "the burning of corpses". He speaks of photographs, that the Allies showed him and the other detainees, and says that that was *"virtually the first time"* that he had seen piles of corpses. The interviewer asked him, what he felt when he saw them, and he replied: *"Just disgust. I couldn't understand it."*

One might think here that what he could not understand was that so many people had been murdered. The statements that followed directly after these, which we wish to examine and analyse in detail here, suggest another assumption. He continues without a break: *"The corpses could- that is- there was no way they could bury these numbers and so on, that they burned them, that is um definitely the case-,"*

What Otto Sonntag could not understand is how there could still be dead bodies around. He continues here to talk about the burning of corpses, going on to say: *"There are several explanations for this, not all of them- so in that sense so we then well, naturally it was discussed,"*

The assumption, that he and the other detainees in Dachau, who were charged with precisely these crimes and some of whom were sentenced to death, talked about how there could still have been so many corpses when they were supposed to have been burned, becomes increasingly plausible. The remark that follows this quote particularly requires some interpretation: *"that way this didn't come out then either, um that now all of them there well were brutally led in gassed and were gone."*

What did not come out here? Presumably Otto Sonntag is referring to murders of which there were no traces because they managed to burn the dead bodies.

The thought that comes to mind at this point is the digging of mass graves and the burning of dead bodies in the East which served to eradicate the traces of murder. Rudolf Hess' statement in the Nuremberg trials in this context was: "The ashes were supposed to be disposed of in such a way that at a later time no conclusions could be drawn about the number of corpses that were burned" (translated from Klee, et al, 1988, p. 246).

Following this logic, Mr. Sonntag then calls into question the number of victims. He says that he read in a book that there were 350,000 and not six million. Thus, his argument that it did not come out that all of them were brutally led in and gassed becomes even more plausible.

In his remarks, Mr. Sonntag is using argumentational figures that are typical of National Socialist circles. Nonetheless, one can assume that the way he concentrates on the theme of the burning of dead bodies has special significance for his particular case. For instance, it begs the question of whether the burning of corpses is connected to the Nazi crimes that he was accused of as well as with his work as a government building surveyor in the Munich *Luftgaukommando*. In connection with our archive research, the question, that occurs to us as the interpreters, is whether Mr. Sonntag had something to do with the construction of crematoria in the concentration camps - like perhaps in the Dachau concentration camp, located near Munich. But independently of this, or rather leaving our suspicions aside, let us proceed to an examination of the interviews with the other members of his family.

The grandmother Frieda<sup>179</sup> (born in 1911) met Otto Sonntag at church; they married in 1935. Both were active in the circle of "German Christians", a National Socialist religious movement formed in 1932 within the German Protestant Church.

Frieda still shares Otto's religious and pointedly National Socialist convictions today. She speaks completely openly in the interview about how she identified with the Nazi movement and how she mourns its passing. She regrets that nowadays "*things aren't so well organized*" as they used to be. She speaks with enthusiasm of her voluntary military service in an armaments factory, which began around 1942. She was impressed by what she experienced of the "German national community", a community that she sought again after the war in the circle of the Protestant Church, i.e. in a religious community.

In the post-war period, she became active in the Protestant Church, doing voluntary service at the *Bahnhofsmision* (the Travellers' Aid Society, a charity organization that offers food and temporary shelter for the homeless) and organizing leisure trips for children to the North Sea as part of the "Home Mission". Together with her husband and children, she went to meetings of the Protestant Family Circle, a group that her daughter describes in the interview as strongly "*German nationalistic and nature-oriented*".

Whereas the religious community allows Frieda Sonntag to establish continuity with the pre-1945 "Nazi national community", and possibly with her activities in Nazi organizations such as the *NS-Frauenschaft* (National Socialist Women's League), Mr. Sonntag presents his faith in the interview as an

---

179 Frieda Sonntag was interviewed by Bettina Völter in 1993. She tried to interfere with our wish to interview her husband a second time.

interpretation of his life as "divine will". This interpretation, one we found he shares with other men implicated in Nazi crimes, allows him to shift the responsibility for his own life, and for his own actions, away from himself.

Mrs. Sonntag takes on a supporting role in the family as far as concealing her husband's past in the war and his imprisonment after 1945 is concerned. Much like the grandmother in the Seewald family (cf. Chapter 6.2.) in the family dialogue, she, too, tries to stop her husband from revealing things. Her grandson Uli told us that he has tried on numerous occasions to confront his grandfather with his doubts about his past and that in these situations, his grandmother always tries to distract him from talking about this theme. Uli says that once she even explicitly reprimanded his grandfather not to answer the question about the "real" reason for his imprisonment in 1946. As our analyses of the interviews show, it was she who created the myth about her husband's rehabilitation that he was imprisoned because of a confusion of names and thus the victim of occupying forces whose research was wrong. The few accounts that Frieda Sonntag gives of her husband's past generally serve to portray him as a victim. Thus, she particularly emphasizes the time during the war that he spent in Russia and the wound that he received there.

Let us look first at the way she talks about her husband's past in her main narration. She does not address the theme of his imprisonment from 1946 to 1947 in this part of the interview. Initially, she reduces her husband's activities during the war years down to the statement: "*.. before our son was born my husband was called up for duty and there I was without a husband the whole six years*".

Then she talks about her difficulties as the mother of a small son during wartime, and speaks about the post-war years, which she evaluates as follows: "*They were worse than the whole wartime*".

After she has spoken about the normalization of her husband's professional career in the fifties and her daily life in the family, Mrs. Sonntag undertakes a temporal flashback and begins the next sequence like this: "*Admittedly, I mustn't conceal the fact that...*". If we were to expect a secret to be revealed here, we would be disappointed. Mrs. Sonntag relates that her husband was wounded in Russia and that he still suffers from the after-effects of the wound today and receives a small pension as a soldier wounded in action. Thus she portrays her husband exclusively in the role of a victim of the war. In the questioning part of the interview, she responds to the question of: "*What ideas did you have about what your husband was doing over there in the six years that you were alone?*" like this:

*"Well of course we listened anxiously to the war reports and exchanged letters. We wrote a lot of letters, I still have them (1) I haven't well (2) destroyed them till now but- (2) we waited for news of whether it was going well ... apart from being in Russia my husband was in Norway then too."*

Why does Mrs. Sonntag play with the idea of destroying the letters? Is she afraid of her husband's enthusiasm for the war being discovered or do the letters also contain other things that she would prefer to "destroy"? When asked about her husband's return from the POW camp, she ends up talking about his arrest after all. Her intention in doing so is primarily to portray the post-war arrests made by the occupying forces, especially France, as criminal acts. She, too, stresses that in Dachau "*very important men, that is, leaders and officers*" were sentenced to death without a trial. With statements like "*they arbitrarily slaughtered the people there*", she depicts the occupying forces as cruel criminals. In contrast, she hardly mentions the people murdered by the Germans. She only addresses the theme of the persecution of the Jews to make it clear to the interviewer that she and her husband did not approve of this crime. In this context, she uses descriptions of the genocide like "*when the business with the Jews came out*" or "*that with the Jews*".

It is also striking that this not-naming of crimes also comes up in connection with her remarks about her husband's activities during the war. She tells us proudly of his status as government building surveyor and that as an architect he built "*barracks and that*".

### *The children Ulrike and Eberhard: Could I become a Nazi or a perpetrator?*

In the interview with the daughter Ulrike, born in spring of 1945, we find a manifest preoccupation with the theme of the persecution of the Jews, whereas in the interview with her brother<sup>180</sup>, born in 1940, this theme is more between the lines. Ulrike particularly torments herself with questions about her mother's and father's behaviour during the Nazi period. She especially wonders how her parents behaved toward the Jewish population, how much they knew about the murder of the Jews and whether they were perhaps implicated in the crimes themselves. She feels threatened by the question of whether her father was involved in the genocide, and tries to avoid it. Nonetheless, this question is recurrently present, especially in her dialogue with her father.

Of the two children, Ulrike is the one who has confronted her father in heated discussions since she was an adolescent, and who provoked him by her political activities in the left-wing student movement and her marriage to a Communist. Ulrike gave birth to a daughter in 1970, now works as a tax consultant and has been divorced for many years. Whereas her brother outwardly appears to be living a successful and well-adjusted life, Ulrike has caused the family distress since her early adolescence and has had considerable psycho-

---

180 Eberhard Sonntag was interviewed by Bettina Völter in 1993. Susanne Rupp interviewed Ulrike twice in 1994.

logical problems. Since the age of fifteen, she has suffered from sleeping disorders and depressions. Even in elementary school, she developed serious fears. She speaks of her *"unpleasant way to school"*, that meant that she had to walk past *"bombed out areas"*. She developed the frightening fantasy: *"that some, men there- or people there attack me, who might come out of the ruins or piles of rubble"*. This fantasy, that she had roughly from the age of six, stayed with her for several years. Ulrike's sleeping disorders began when for the first time, at school, she found out about the genocide perpetrated against the Jews and confronted her father with questions. She herself considers many reasons for her insomnia but sees no connection on a conscious level with her father's past. Rather she thinks about the possible influence of the last few months of the war on her mother's pregnancy, adding: *"I always have to find some pretext or other to blame it on"*. Even in this statement, there is a suggestion that this explanation fails to satisfy her when it comes down to it, something she herself then explicitly expresses.

At the age of fifteen, prompted by her lesson at school, Ulrike began to instigate heated arguments with her father because he supported the Nazi system, was a member of the SA and continues to hold strong National Socialist convictions. She was forced to realize that her father reads the *Nationalzeitung* and shares the opinions expressed there. She particularly fought with him about the following question: *"'Didn't you realize it would end up like that with the Jews being being deported'. And 'how can it be that you didn't realize it, didn't you try to stop it?'"*

Ulrike says that her father's response to this was: *"We couldn't really realize it and and and but when we did realize it of course we didn't approve of it but if you somehow tried to stop it then, you couldn't any more"*

She says that her father always got very upset in these situations and felt unjustly accused. She says that once he even dropped the remark: *"You would have done it too"*. Today Ulrike reproaches herself for perhaps asking too polemically and for not having the capability at the time of *"thinking her way into a system like that"*. She argues that she is also unsure to what extent she might be susceptible to National Socialist values, too, in a certain social situation. During this sequence she begins to cry, asks for a break in the interview and leaves the room.

Returning from the next room somewhat more composed, she tells the interviewer that she does not know how she would react if she knew that her father had been actively involved in the annihilation of the Jews. She adds that she can understand people who simply cannot believe that their parents were actively involved in the crimes. She says that she herself has never dared to ask her father whether he was actively involved. Ulrike knows hardly anything about his father's past during the Nazi period. She says that he was in a Russian POW camp and later in a French one, too. In passing, she mentions his arrest and unquestioningly accepts the story of the "confusion of names":

*"Yeah and in fact once he was somehow now I remember something he said he was somehow mistaken for someone else that is names they were looking for like someone with the same name. And he told us that one time. I forget the details now and that was a mistake there he was locked up for somebody else. I think that was in France."*

It is striking that in the interview she completely confuses historical and family history dates again and again or says that she has forgotten them. Thus, on a number of occasions she asks when World War II was, when it started and when it ended. On one occasion, Ulrike, who was born at the end of the war in the spring of 1945, actually places herself as a baby during the war, i.e. she perceives herself as a baby in the prenatal phase. She relates having spent the nights during the war in a bunker with her mother and brother. She also says that her father was still away in the war when she was born. She says that in 1946 he came "on leave". These confusions about time bear a temporal correlation to her father's arrest and imprisonment. Ulrike speaks of her father's absence in this period as if it were brought on by the war. We can assume that these "linguistic prescriptions" were presumably transmitted in the family or that the then two-or three-year-old Ulrike was given the impression at the time that her father was still in the war.

We also find out from Ulrike about another description of the family past or another family secret. Her sister-in-law had already told us in her interview that Frieda's brother, a convinced member of the NSDAP, had killed himself when the Nazi system collapsed in 1945. In the first interview, Ulrike says that this uncle was killed in the war. She says that her mother loved this brother very much and often talked to her about him: *"she ((the mother)) found it very hard that he got killed"*. Then in the second interview, Ulrike says that she had spoken to her brother in the meantime on the telephone and that he had told her that this uncle had killed himself. She adds that she guesses she knew this once but had forgotten it again or pushed it out of her mind in the meantime. Ulrike repeatedly says sorry for continually forgetting dates and details from stories that she has been told. Thus for instance, she asks the interviewer how many million Jews were murdered; saying that she could not remember the number just at the moment. In response to many of the interviewer's questions about her family history, she emphasizes that her parents certainly must have told her about the subject in question, just that she has gone and forgotten it. By doing so, she is taking the blame for not knowing and thus exonerating her parents from the potential reproach that they are concealing something. In general, she accuses herself, heaps reproaches upon herself and avoids any criticism of her parents. What is more, she accuses herself of having presumably adopted her father's patterns of thinking.

Ulrike had a daughter from her former marriage. Silke had just finished her degree when we interviewed her. About a year after the interview, we found out to our great dismay that she had taken her own life.

The symptoms of forgetting, not being able to remember and confusing dates, accompanied by self-accusation, that were so striking in Ulrike's case, were something we found in the interview with her daughter in an even more striking form. Silke, born in 1970, said repeatedly that her grandfather had told her a lot about the war. However, she could not remember anything he said about it. The gaps in her memory also extended to her own life. Time and again she tried desperately to cooperate with the interviewer, but then fell silent and said she could not remember anything any more. And yet it was she who had initiated a discussion with her grandfather about his imprisonment in Dachau and had visited the memorial herself.

Let us turn now to the son of the Sonntag family, Eberhard. Born in 1940, Eberhard is married to a woman the same age as himself, is a secondary school teacher and the father of two children.

How does he deal with his father's past? Eberhard Sonntag never addresses this theme directly in the interview. He neither speaks about what his father did during the war nor about the latter's past as a National Socialist and SA leader. In the interview with his sister, we discover that she just recently confronted him with the fact that their father was a member of the SA, and that his response was: *"I don't believe it"*. His answers to the interviewer's repeated questions about his father's Nazi past show very clearly how fiercely he resists knowing about it. Once he says that he cannot remember where his father was during the war, and another time he says that he has forgotten where he was. While he can remember that his father came home from the war on leave from Norway, Eberhard Sonntag says that he does not quite know any more whether he was in Russia or France as well. Referring to France, he reflects that: *"I think he was in France too, but like I said I don't know all that much about his missions in the war. Just because he never said anything about it of his own accord and I don't exactly have a burning interest in it myself either."*

If Eberhard were to have a burning interest in it, it would become too threatening for him. In a figurative sense we can put it the following way: instead of taking an interest in it, he prefers to play with fire. This assumption comes to mind in a very literal sense if one examines his account of the post-war period. He does not speak of his father's imprisonment in Dachau, which as a six-year-old at the time who already went to school, was presumably not very nice for him, but rather tells us about the games he used to play in a former bunker<sup>181</sup>. He relates that he and his playmates often found duds there and: *"sometimes we made a little fire and threw them in there, were murderously happy when the stuff exploded and we had our wounded too"*. Eberhard

---

181 Even if we accept that these games were biographically more relevant to the then six-year-old boy than his father's imprisonment and that this presentation is therefore an expression of his perspective of the past, this coherent description without any distancing in an interview situation by a 43-year-old narrator requires some interpretation.



Sonntag is thus murderously happy when fire and explosions are involved. He also says that once a splinter injured an older boy's leg and that he bled. Eberhard's comment on this was: *"That impressed me then too, have a look at that, well"*.

This depiction of someone else's injury, portrayed more as "impressive" than oppressive, is mirrored in his descriptions of his own injuries, especially a burn that he once suffered. When he was about eighteen years old, as leader of a Protestant youth group, Eberhard organized a summer solstice celebration. He had the others gather firewood and make a pile of wood. He poured a can of gasoline on it, took a match, and lit a piece of paper to set the pile of wood on fire. Laughing, he goes on to say: *"I had shorts on and short sleeves and my my legs\ ((laughing)) and my arms got pretty burned. I mean I just about had to go to hospital. That was well \an experience with fire\ ((laughing)). But that has nothing to do with the war"*.

One could interpret this laughing as a defence mechanism against remembering this experience. However, the suspicion that it is self-punishment also arises. Just what Eberhard Sonntag has to punish himself for is something he indicates himself in this sequence, by denying a connection to the war. This denial is all the more striking in that the preceding sequences are not about the war.

The extent to which fire and war are two associated themes for Eberhard Sonntag becomes clear if one examines the themes and ideas that mainly concern him in connection with the Nazi crimes. The recurrent topic is the crimes in Oradour, the ruins of which Eberhard Sonntag and his family have visited. This mass murder was committed on 10 June 1944 by members of the Second SS Armored Division *"Das Reich"* on their march from the South of France to Normandy. "On the pretext that the villagers had hidden explosives (and partisans, G.R.), they were rounded up in the village square, men and youths were shot on the spot, the women and small children were burned alive in the village church and the village was razed to the ground" (translation of *Deutschland im Zweiten Weltkrieg*, 1986, Vol. 5, p. 651). Eberhard Sonntag repeatedly torments himself with this question:

*"I ask myself again and again how would you have reacted in a situation like that and uh- (2 second pause) those who engage in guerrilla warfare, who go into the Resistance, who take off their uniform and mow down soldiers from behind, they have to reckon with one knowing no mercy if one catches them. That was the risk they were taking."*

Here Eberhard is taking the point of view of the supreme command of the *Wehrmacht*, who refused to acknowledge the French Résistance fighters as regular soldiers and gave the order to shoot prisoners, thus violating international law. But he goes one step further, putting himself in the position of the commanding officer and not really seeing any alternative course of action

open to him to murdering civilians. He also considers whether he himself would be able to drive people into a church and set it on fire:

*"I don't know, I don't think that even under the most extreme conditions I would have done that, that I would have driven civilians, even if they had hidden and covered for their Resistance fighters, into a church and had the men set fire to it. Well I I I don't think that I, that I would've been capable of doing that, but I wouldn't put my hand in the fire to prove it not for anyone not even for myself".*

If he cannot even "put his hand in the fire" to vouch for himself, how then should he be able to do it for his father. If we bear in mind how he laughed during his account of how he burned himself at the summer solstice fire, this section of the text makes the assumption of a possible tendency to self-punishment even more plausible. When the interviewer asks him whether he has fantasies about what his father did, he replies: *"Do you think I imagine that my father had an order to comb a valley and look for partisans?"* He rebuffs this self-imagined content of the question, saying: *"Actually I ask myself the question less in relation to my father, that doesn't interest me as much as in relation to myself".* Instead of facing his father's possible guilt, he torments himself, as does his sister, with his own potential guilt. This mechanism is often observed in sons and daughters of Nazi perpetrators who do not ask themselves the question of guilt<sup>182</sup>.

To exonerate himself from his father's guilt as well as his own potential guilt, in the interview Eberhard Sonntag repeatedly argues the injustice of the French Résistance. His main theme in connection with the Nazi crimes is the legitimacy of fighting the partisans, an argument put forward by members of the *Wehrmacht* and other Nazi associations as legitimization for the murders they committed. Even the mass shootings of the Jewish population in Russia were legitimized in connection with fighting the partisans (cf. Browning 1993; Krausnick 1985, p. 214 ff).<sup>183</sup> It becomes clear in the interview text that members of the Resistance or partisans and concentration camp inmates or Jews are two associated themes for Eberhard Sonntag. Thus, for example, he says that once he was invited to a French home and that they had had a guest: *"well he was- um now was he in a concentration camp or was he in the Resistance?"* He cannot remember this, nor what this guest said at the time,

---

182 This is revealed in the interviews of Dan Bar-On 1993a, Peter Sichrovsky 1987 and Dörte von Westerhagen 1987.

183 Under the pretext of fighting partisan bands, the Nazis pressed on with the annihilation of the Jews. "...but in fact an assumed prejudice and years of propaganda had created an inner willingness in many soldiers and officers to equate Jews in the occupied Eastern territories with partisans, 'suspected partisans' or 'partisan accomplices' from the outset" (translation of Krausnick 1985, p. 217). It was propagated that the links between the partisan units themselves were maintained 'mainly through Jews' and therefore these villages were to be made 'Jew-free'. (ibid.)

only that he himself was of another opinion than the guest and that he "gave him a piece of his mind". When asked whether this man had been in a concentration camp or not, he then says: *"maybe I've blocked it out of my mind"*.

The function that the argument about the French Résistance and the partisans can have becomes obvious. Eberhard Sonntag uses it to avoid addressing the theme of racial persecution. If the murder of members of the Résistance can still be argued in the context of a military procedure during the war, this becomes more difficult when it comes to the theme of murdered Jews. When Eberhard Sonntag speaks of concentration camps in general, Jews do not figure as people. In fact, he altogether rejects the public documentation of the crimes in the concentration camps. During a visit to the concentration camp of Struthof/Natzweiler in Alsace - at first he repeatedly speaks of Stutthof, the name of the former concentration camp near Danzig -, he got very angry about young people from Alsace being taken there *"and shown all this so clearly, what their evil neighbours to the East got up to"*.

Almost at the end of the interview, Eberhard Sonntag does talk about Jews after all. However, the Jews in this sequence do not figure as victims at all, but rather as judges in the Eichmann trial: *"The Israelis went and got Eichmann and burned him to ashes. Of course that was clear from the start,"*

Thus he does not speak here about the legal proceedings, but right away about the burning of Eichmann's body and goes on to say:

*"and somehow I can understand it, if you've endured so much and now you've got someone you can pin it on, that you let out your anger on him. I mean that was a symbolic gesture to scatter his ashes over the ocean, far more for the Israelis than for us, because if you know what being buried means to the Jew than basically it was a condemnation going into eternity beyond death"*.

This sequence of the text is the first time in the interview that Eberhard Sonntag actually says the word "Jew" and, in a typically anti-Semitic way, he uses it in the singular. He says that he understands the Israelis' behaviour, and yet he puts it into categories of personal revenge - like letting out anger - and not into categories of judicial decisions and criminal prosecution. Thus towards the end of the interview, "The Jew" is introduced here in the role of avenger and not as a victim of persecution. Instead of thinking of the burned corpses of Jews, as his father does, Eberhard Sonntag speaks of the burned corpse of Eichmann and by doing so, avoids addressing the theme of the Holocaust. A parallel emerges here with his preoccupation with the French Résistance. By focusing his thinking on the actions of members of the Resistance and judges of the people persecuted by the Germans, and not on their suffering, this member of the second generation born of Nazi parents evades thinking about the deeds perpetrated by the Germans in the process of annihilation.

## *The grandson: fluctuating between exposing and concealing*

Let us undertake a change of perspective and take a look at the grandson, Eberhard Sonntag's son. Uli was the one who made contact with us and expressed an interest in taking part in our interviews. He asked his parents and grandparents to take part and "persuaded" them to do so. Thus, the first interview in this family was conducted by Gabriele Rosenthal and Bettina Völter with him in 1993. In the family he takes on the delegation of opening up the dialogue about his grandfather's past and atoning for his deeds (cf. Stierlin 1981, p. 389).

Uli Sonntag was born in 1971. During his school years, he became very politically active and joined a right-wing environmentalist party. After finishing high school, he went through a political change of heart, choosing to do two years of alternative service (instead of compulsory military service) in France as part of the "*Aktion Sühnezeichen*" (Sign of Atonement Program). He worked near a village that was destroyed in 1944 by police and SS units. Here, too, women and children were burned in a church.

Unlike his father, Uli does not attempt to justify these crimes. He only exonerates the Germans by saying: "*It wasn't just a German SS unit, but also lots of convicts from Russia who were sent there*".

During the time he spent in France, there was a fire in Uli's apartment. His reaction to it was complete panic. Even today he is haunted by a fear of fire. He has a recurrent dream that he is in his old childhood bedroom, that it is on fire and he cannot get out of the room. On the whole, Uli has strong fears, fears of persecution, which he channels into fear of skinheads and neo-Nazis.

Uli Sonntag confronts his grandfather's past far more than his father does. He is very hesitantly moving closer to the question of what could be behind his grandfather's imprisonment in Dachau. He says that he has his fantasies about what it could be, but is unable to express them in the interview. Nonetheless it becomes indirectly clear what kind of fantasies he torments himself with, but without being aware of the connection to his grandfather's alleged past.

Uli mainly talks about the Nazi crimes in connection with his experiences on the *Aktion Sühnezeichen* program. Once he went with the others to a Jewish cemetery to pull out weeds (!), and they also went to the Stutthof concentration camp memorial in Poland. In response to a request for more details of what he remembered from his visit to Stutthof, the first thing he described is the place where the pyre<sup>184</sup> used to be - and in Uli's words - "*where the bodies*

---

184 During the typhus epidemic at the end of 1944/ beginning of 1945, the crematorium in Stutthof did not have the capacity to burn all the bodies, so "a pyre was constructed to the north of the New Camp. The corpses were piled in layers and doused with fuel to make them burn better" (translation of Skutnik 1979, p. 22).

were burned". As his remarks on the theme of Nazi crimes indicate, the burning of people - on the pyre or locked in a church - is a key component of his fantasies. One of his comments about the pyre in Stutthof was: *"Another thing I'm not so sure about is whether they didn't also throw people on it who were still a bit alive"*. As in so many other parts of the interview, he is shocked by his wording, here *"a bit alive"*, and says that sometimes he has laughed in the context of this theme. He explains his behaviour to himself through the grotesqueness of these situations where nothing that happened was normal and reflects on his feelings, which frighten him: *"When I think about it, and that's the awful thing about it (4), well I feel an interest in how such a situation came-how- (2) an interest in this GROTESQUENESS (2) it's AWFUL"*.

Directly after this remark, he nearly burns himself on the flame that shoots up from his lighter. This is not the first time that this has happened during the interview. Uli has his lighter adjusted to the highest flame and every time he lights a cigarette, he starts back fearfully from the flame. At this point, the interviewer says to him: *"But you're not trying to punish yourself"*. He replies: *"No, sometimes yes"*. Without any further pause - normally he pauses often and, more importantly, for a noticeably long time - he goes on to relate how he met some young Israelis, saying: *"I acted very strangely- that is- (1) differently towards them, because I knew they were Jews"*. The thematic connection between these consecutive sequences is thus: the burning of "bodies" in Stutthof, his punishing with the flames that shoot up from his lighter and his encounter with Jews in the present.

Following the theme "encounter with the Israelis", Uli reads out some of the notes that he made in his diary around the time that he visited the Stutthof memorial. He reads a poem in which he writes of himself in the plural of the dead whose faith was taken from them in the gas chamber and in the crematorium. He speaks of "our ashes" and "our burning" on the pyre. His other notes are also entirely from the perspective of the inmates whose - as Uli emphasizes - humanity was stolen from them.

He does not speak of the perpetrators, thus making himself a victim of perpetrators that he makes anonymous. When asked whether he sees himself in the position of inmate, he lights the darting flame of his lighter, starts back from the flame and says that he constantly sees himself in the role of perpetrator, too. He argues that someone like him, who conforms to the extent that he does and avoids conflicts, could become a perpetrator just by following orders. He says that he particularly notices his tendency to conform and willingness to "carry out orders" in his behaviour towards his family of origin, whose expectations he is always trying to live up to.

It becomes increasingly obvious that in this family, like the son and daughter before him, the grandson also torments himself with the question of his own potential perpetration of crimes, while at the same time the actual perpetrator remains anonymous. However, the grandson in this family goes a

significant step further than his father. While Uli openly accuses himself of potentially committing an immoral deed, Eberhard on the other hand tries to exonerate the perpetrators and blame the victims by taking on the perspective of the perpetrator. In contrast, the strategy of assigning the guilt to the victims is not at all present in the case of the grandson. In his case, other evasion tendencies come to the fore. In both his account of his visit to Stutthof and his description of his work at the Jewish cemetery, it emerges that he wishes to avoid the theme of "horror at the crimes" through the theme of "the beauty of nature". Referring to his visit to the cemetery, he says: *"and then just this well wonderful graveyard, this atmosphere, then walking through it. We did a bit of a tour, how the gravestones are entwined in ivy and are already pretty much falling apart. You feel how nature has taken over there."*

In addition to Uli's conscious intention "not to forget", an unconscious desire becomes apparent here to let history grow over with the help of nature. Thus he adds: *"Well at first somehow the thoughts of why even weed here when it looks so beautiful when it's overgrown."* If we interpret this statement in its wider sense, we can formulate the assumption that Uli's relationship to nature and his commitment to environmental protection serve to "conceal". Unconsciously, he wishes to cover up the crimes with nature. It is thus not surprising that Uli can no longer remember the name on the grave that he cleared of weeds. Uli's desire to conceal and yet also to expose is apparent time and again when he speaks of his grandfather Otto. Thus he reproaches him for his repeatedly expressed anti-Semitism, but cannot manage to quote his grandfather. He speaks of the many situations in which the theme of Jews "is present", his grandfather makes some comment or other and there is a certain amount of aggression in the air. When asked by the interviewer to recount one such situation, he begins a story, but starts to stammer and stutter more and more and cannot utter the statements his grandfather made, which he does, however, remember at that point. It comes out in the interview time and again that Uli has to protect his grandfather and cannot accuse him, so as - as he says - not to hurt him. He also has to protect him, because he does not want to hurt himself. Uli's way of dealing with his past is a constant fluctuation between exposing and concealing. As the interview and several follow-up interviews with him reveal, his grandfather's uncandidness torments him. He senses the dubiousness of his grandfather's statements; this even goes so far that he sometimes doubts the versions of stories his grandfather tells him about situations in daily life. Whereas his father does not question the version of the wrongful imprisonment of the grandfather in Dachau, Uli concerns himself with the mysteriousness of this part of the family history. The following sequence of text complete with paralingual utterances serves to clarify how much this weighs on him: *"Naturally about THAT I have my fa- about THAT I naturally have fantasies like why does he tell me he didn't understand, uhuhuhuh uh why they brought him to DACHAU, uhum (1) again*

*well=first of all the questions well were=uhuh (1) who were the ones brought to Dachau again, why who=uh, what was the reason well=p=p=p=p-presumably officers or=uh, uhuh people who: (1) \well maybe'((whispering soundlessly))\ ((breaths out)) (1) well war CRIminals too some- some of them who then, whom they wanted to wh-, like=uh a kinda denazification again they wanted to show them, uhuh what one o' these concentration camps looks like 'cause the=uh- (1) ((bangs on the table)) well they didn't do it with EVE-RYbody, fo- uh well I think about the reasons for that alright and uh what's behind it ((very animatedly))\ and why does he have to say he- he still doesn't understand it what does he mean by that".*

He subsequently expresses his incomprehension about his father's lack of questions: *"My father must have a need to know this too, he's bound to have been given a certain image of the story too"... "if he's got a specific idea in his mind but doesn't verify it with reality and doesn't ask...out of fear".*

### *Concluding remarks*

Both children in this family have to exert a great deal of energy to not realize the significance of their parents' contradictory statements and to evade the fragments of family history that are passed on to them. Because they have so little access to their family past, their fantasies gain in strength. The son, the daughter and the grandson, too, torment themselves with the question of possible perpetrator traits in themselves and develop tendencies towards self-punishment.

It becomes apparent in the family presented here, however, how much the grandson faces up to a confrontation with his family history, despite all the strain that he is under, while his father continues to use the strategy of assigning the guilt to the victims as a defence against thinking about the crimes and as a means of repairing the incriminated family past. His sister, the daughter of Otto and Frieda Sonntag, also evades a confrontation with her parents' past. In her case, as in that of her daughter, this leads to considerable gaps in her memory. In the case of the granddaughter, these gaps even extended to her memory of her own life history. In contrast, the grandson expresses himself how much on the one hand he would like a more open dialogue with his grandfather, but how afraid of it he is, on the other. He acts out the past, as we observed happening in other families as well, with symptoms based on his fantasies. His fantasies about "the burning of people" are reflected in his nightmares, his identification with the people who were burned and his type of self-punishment; he acts out his family's guilt through self-accusations and fears of persecution.

Self-accusations, fears of persecution as well as insomnia and depression were symptoms we also found in his aunt, the daughter of the Sonntag family.

She is the one in the second generation who seems to be broken by the family past and now, with her daughter's suicide, her life has been shaken up just as dramatically again. However, she is also the one who has not "put up a wall of armour" around herself like her brother has, and who does not pass the guilt on to anyone else.



## 18. We are the victims of history: The Seewald family

Bettina Völter and Gabriele Rosenthal

### *Preliminary Remarks*

The grandparents Anna and Hans Seewald live in a small village on former East German territory. They live in Anna's family home. Mechthild, their daughter, lived in a second house on the same property for many years, until she moved to a neighbouring village with her husband and children.<sup>185</sup>

Both villages are near the former concentration camp of Sachsenhausen, considered to have been the second-largest concentration camp under the Nazi regime (Hrdlicka 1992, p. 45 f). Between 1936 and 1945, a total of 200,000 people from 20 nations were incarcerated here, including Soviet prisoners of war, Poles, Jews, Sinti and Roma. Thousands of inmates were shot, tortured to death and their bodies burned in Sachsenhausen. Most died of exhaustion and undernourishment. Every second inmate did not survive incarceration. In autumn 1941, the SS shot 18,000 Soviet prisoners of war within a matter of weeks. Their bodies were burned in the crematorium and an unbearable stench hung over the camp and its environs (Autorenkollektiv 1974, p. 64f). Experiments were also made with using a railroad car to gas Soviet prisoners of war and probably a gas chamber was also built in 1943 (Enzyklopädie 1995, p. 1270).

When the Red Army liberated Sachsenhausen on April 22 1945, there were only 3000 inmates left in the camp, most of them in a very poor state of health and unable to walk. Just days before, 33,000 camp inmates had been sent on a death march towards the Baltic Sea. Some 3000 inmates died on this march. Those who could no longer walk were "shot on the spot in a roadside ditch" (Autorenkollektiv 1974, p. 123). After the liberation, approximately 1000 people initially remained in the camp. They were given medical attention by the army doctors and medics of the Soviet and Polish armies. Civilians from the surrounding area were also brought in for this purpose. A military hospital in Berlin took over the makeshift hospital in early May.

---

185 In the Seewald family, we interviewed the grandmother Anna Seewald, the grandfather Hans Seewald, their daughter Mechthild and granddaughter Petra and her husband Frank. The grandparents, their daughter and their granddaughter took part in a family interview (cf. Chapter 6).

The grounds and buildings of the former concentration camp were used by the Soviet occupying power from August 1945 onward to set up an internment camp. Between spring and autumn 1945 in all four of Germany's occupied zones, the Allied forces arrested and imprisoned hundreds of thousands of supporters of the Nazi regime, initially to prevent armed resistance, acts of terror and underground activities. The wave of arrests in the Soviet-occupied zone was carried out on the basis of a paragraph used in the Soviet Union during the Stalinist purges of the thirties. In summary proceedings, tribunals passed sentences of ten, fifteen or twenty-five years forced labour, often without a comprehensible charge and without legal counsel. In the months directly after the liberation, many low-level and medium-level Nazi functionaries, party members and above all young people, who had belonged to National Socialist organizations, were interned. In the years that followed, being suspected of "espionage and agent activities" or "anti-Soviet propaganda" was grounds for internment or deportation, often to the Vorkuta Gulag. Among the victims were (alleged) opponents of social restructuring in the Soviet-occupied zone, members of bourgeois parties, Social Democrats, but also numerous members of the SED considered to be unreliable, former members of the KPD and members of left-wing Socialist splinter groups (Agde 1993, p. 9-27; Finn 1995, p. 344f). The internment camps were not concentration camps like the National Socialist ones; no systematic torturing or murdering of prisoners took place in them. But the death rate was very high nonetheless. Between 1945 and 1950, more than a third of the camp inmates in "Special Camp No. 7", some 13,000 people, perished because of the miserable living conditions (German Lower House of Parliament publication, 1995, p. 368). To prevent any actual figures from coming out, the corpses were buried in mass burials at night in a nearby clearing or in the headquarters courtyard. The surviving prisoners were completely cut off from the outside world. Prisoners who were released had to take an oath of silence first (Hrdlicka 1992, p. 143; Agde 1993, p. 9-27). This chapter of the post-war period was taboo in East Germany, even long after the "Special Camps" were closed down. However, after the changes in 1989, the area around the former Sachsenhausen concentration and internment camp became the subject of public discussion. The memorial was redesigned. For the first time, the grave fields were marked in the nearby forest where the corpses from "Special Camp No. 7" lie buried.

We discover from the interviews with the Seewald family that the grandparents Anna and Hans Seewald witnessed what went on around the camp near them. During the Nazi period, they saw inmates from the concentration camp almost every day. These prisoners were made to do forced labour in various installations in the surrounding area and had to march in long gangs of workers from the camp to the outlying installations. On her way to work, the grandmother Anna Seewald regularly met one of these teams of forced

labourers. Our historical research shows that the team she encountered was one of over 2000 prisoners on their way to a brickwork, one of the most notorious outlying installations. The inmates there were so maltreated that an average of 30 people a day died working there.

The grandfather Hans Seewald had daily contact with concentration camp inmates until he was called up for military service in 1943. The inmates' labour was also exploited in numerous other large-scale enterprises in the surrounding area. In 1940 for instance, Hans Seewald's company, a factory run by Heinkelwerk, had some 7000 camp inmates and forced labourers working at it. Hundreds of other inmates worked on a stretch of railroad track intended to serve the factory as a feeder line.

Despite the fact that the grandparents witnessed this, all family members spoke of the theme of crimes against humanity only when asked about them by us interviewers. Rather, in their initial presentation of their family past during the Nazi period, they endeavoured to present themselves or their family as victims of World War I and World War II and the Soviet power. In interviews with all of the family members, the theme of "fear of the Russians" plays a key role. The grandmother Anna Seewald hints at an experience that she herself had with "the Russians", but does not want to talk about it. The experiences or deeds that motivate her fear remain more or less in the dark. No one in the family speaks of the internment camp which was run by the Soviet occupying power up until 1950, but they do address the theme of the mass graves in the forest near the grandparents' village where the corpses from "Special Camp No. 7" are buried.

We are given hints in the interviews that after being called up to the *Wehrmacht* in 1943, the grandfather may have been involved in the shooting of Russian prisoners of war and Jews in the Soviet Union and that this is the reason why he feared criminal prosecution after the war. But he speaks only hesitantly of his fears in the post-war period. There are, in fact, a number of family secrets in the Seewald family. Some are revealed in the interviews. Particularly striking in this context is that nearly all the interviewees who revealed secrets forbade the interviewers to ask questions about them. The interviewees mentioned various parts of their family history that we were absolutely not to ask other family members about or which they themselves did not want to talk about. Our analyses suggest that by revealing certain secrets they were able to distract attention from the secrets that they were apparently supposed to make every effort to conceal.

## *The Seewald grandparents: blaming the Jews*

The grandmother Anna Seewald<sup>186</sup>, the youngest of ten children, was born in 1921 into a family of agricultural labourers. Her father had been seriously wounded in World War I and had to give up his trade. Later, Anna heard that her mother and her siblings had been opposed to another child but that her father had reassured her mother: *"I wasn't supposed to be born at all. But then my father comforted my mother: 'There, there, maybe the child will be our mainstay later in life'. Well, and that's how it turned out."*

Anna's early childhood was marked by the family's social decline as a result of the war. But after just a few years, her parents' economic situation improved. Anna's significantly older sisters and brothers left their parents' home one by one and were able to support the family financially. Finally, in the mid-twenties, her parents bought a small property with a little house on it from the money they had saved up. But the first winter in the new house was very cold. Anna was five years old and became sick with rheumatic fever. The family could not afford a doctor. Anna's mother nursed her for several months. This is one of the reasons why she feels very bound to her: *"I always owed her gratitude, and I did right by her in everything."*

While she was growing up, Anna reconciled herself to the role of the daughter who is the only child to stay with her parents to support and look after them. In exchange, her parents gave her preferential treatment. Whereas her older sisters were not allowed to learn a trade, Anna was apprenticed to a tailor in 1935 at the age of fifteen. She and her family took a positive view of the Nazi regime. She says today that after 1933 her father found work again:

*"Life really began for us when Adolf Hitler was elected. He created jobs for everyone. He kept going further and further, getting more and more courageous. Some people saw it coming that he would plunge us into war. But we had a good life. And I shouted "Heil Hitler", too."*

In retrospective, Anna presents the handing over of power to Hitler as a turning point for her family in terms of easing their financial situation. In doing so, she loses sight of the fact that her family's financial state improved as of the mid- or late twenties. From her present-day perspective, Anna differentiates between the *"bad life"* before 1933 and the *"good life"* between 1933 and 1945, thus justifying her family's enthusiasm for the National Socialist regime. But we only find out about the *"good life"* under National Socialism when we question her about it, for in the main narration, Anna jumps straight to the summer of 1945. In the first part of the interview, she speaks neither about her work as a nurse in a military hospital nor about the period directly after the war when the hospital was taken over by the Soviet occupying

---

186 Anna Seewald was interviewed by Gabriele Rosenthal in 1993.

power. It is only in the questioning part of the interview that Mrs. Seewald tells us of how she took a first-aid course and was assigned to a military hospital in Berlin as a nurse. We can assume that she carried out this work from the beginning of the war as part of the war support service (*Kriegshilfsdienst*) after she had done her compulsory national work service (*Reichsarbeitsdienst*) - perhaps also as an assistant nurse.<sup>187</sup> As a twenty-four-year-old in Berlin, she lived through the last battles for the capital and the ensuing occupation. As the interviewer's pointed questions led us to discover later in the interview, Anna was convinced of the "Final Victory" until the very end and identified with Hitler:

*"On the radio they said: 'The Fuehrer has now taken over personal control of the Reich capital. He is at the very head of his troops.' The windows were already all broken. I still thought we would win the war then (...) I mean, my brothers couldn't have given their lives for nothing."*

By the end of the war, of her five brothers, one had died and another brother as well as her brother-in-law Gernot were missing in action.

Let us initially skip over Anna's experiences during the Nazi period and the period directly after the end of the war, the months after the Soviet occupying power took over the military hospital. Let us first examine what Anna tells us in her main narration. She mentions that her mother died and that a few years later her father did, too. She says her mother suffered from coronary arteriosclerosis. Anna says that the death of her parents hit her very hard as a young woman, and that she nearly lost the will to live. She only took hope from the information given to her by a fortune-teller, assuring her that her fiancé would return from the POW camp. Anna had become engaged to Hans Seewald, a friend of her brother-in-law Gernot, in 1944. He had visited the family for many years and long courted Anna. But she herself could hardly imagine marrying a man before her parents' death: *"Well I had my mother"*.

The story of the fortune-teller who predicted his return is one Hans Seewald enjoys telling and tells regularly. Including the fact that the contrary was predicted for Anna's sister. And both predictions came true: in 1949, Hans Seewald returned, but Anna's brother-in-law Gernot did not. The family say of the latter that he was sentenced as a war criminal in the Soviet Union. Anna married her fiancé as soon as he returned: *"My good life started from then on."* As the sole heiress, she inherited her father's house and property, on

---

187 According to a law that came into effect June 26 1935, every young person over eighteen years of age could be called upon to do half a year of service in the Reichsarbeitsdienst. From the beginning of the war on, all single women between 17 and 25 who were not in full-time employment or training could be recruited into the Reichsarbeitsdienst. After completing their Reichsarbeitsdienst, women were supposed to do half a year of war support service, in hospitals and social institutions, etc.

which she could build a future with her husband. One year later, the couple had a daughter, Mechthild.

Anna concludes the first part of her narrative with the overall evaluation: "*Then my good life started*". She has arrived at 1949 in her story. Anna presents herself and her family as victims of World War I and II and justifies her enthusiasm for National Socialism with an argument that is widespread in German society, namely, that Hitler gave the family work. But she does not initially mention the period between 1933 and 1945 or her work as a nurse in a military hospital in Berlin under the Soviet occupying power. Anna's story is also characterized by its reduction to a description of the internal life of her family. The interviewee hardly speaks of life outside of this nucleus. She and her family appear simply to be victims of the ominous movements in society.

It is only once the interview has been going on for several hours, after the interviewer has asked her specific questions about what she knew about the persecution that Anna Seewald mentions that from 1936 on she passed inmates from the nearby outlying installation of the Sachsenhausen concentration camp every day on her way to work: "*The inmates always marched to F. at that time. The ones who couldn't walk any more were carried by their colleagues ... That was horrible. But we knew nothing AT ALL it all went on behind walls.*"

Anna depicts an image of an unsuspecting young person who had to let horror march past her every day and yet knew nothing at all. Even today, she still legitimizes the incarceration of the inmates with arguments like: "*Well I thought probably because they didn't support Adolf Hitler. But later I found out there were also also also murderers in there.*"

The driving out and incarceration of the Jewish population as well as the expropriation of Jewish property that occurred on her doorstep is something she only mentions after repeated questioning. She states: "*The Jews somehow all had shops, they were all doing well.*" We discover that many of the buildings in her neighbourhood used to belong to Jewish families who had to emigrate or were put on transports: "*All the bungalows that were here, they were all Jews from Berlin. Other people couldn't afford bungalows*". Then the interviewer wanted Anna Seewald to tell her what happened to these buildings and properties:

Interviewer: And then Nazis took over these buildings,

Anna: Nah they just stood = empty all the time and it was- only now after forty-five then- somehow (1) Well some of them managed to sell up. Here over there for example diagonally across there- used to be Jews too before they had a big shoe store in Berlin".

Once Mrs. Seewald began to talk about the owners of the property opposite, a lengthy pause ensued in which she played with the coffee cups and saucers on

the table, the table rocked, Mrs. Seewald hummed and hawed, repeatedly brushed her legs with the palms of her hands, cleared her throat and then continued composed and emphatic: *"and then they went away too but-"*. She cut short what she was saying, and we do not find out who bought or took possession of this or other properties. We discover from the interview with her husband Hans Seewald that Anna's sister and her husband Gernot lived across the way and that the sister later fled to West Germany. Furthermore, one of Anna's brothers lives in one of the "bungalows", as Anna calls them, opposite. But Anna does not speak about that in this context, rather she proceeds to assert that the *"big, rich Jews"* were responsible for the murder of the *"small"*, poor Jews: *"The big ones always just went away, and didn't take their small ones with them, they had to stay here and then they had to bleed. I didn't think that was very nice, always just the small ones."*

Later, when the tape was not recording for a little while, Anna describes how she and her husband *"hid themselves away"* in one of the three little houses away from the road at the back of their property, so they could not be seen from outside. Who were Anna and her husband afraid of? Why did they have to hide themselves away in a little house? And, the one they hid in happened to be the one that stood there when she was a child. There are other themes as well that Anna does not wish to go into detail about in the interview. In particular, she refuses to answer questions about her experiences with the Soviet occupying force. She is generally sceptical about the consequences of the interview. When the interviewer changes the tape, Anna remarks: *"What I've been telling you is on the tape. But what if the Russians come back?"* Is Mrs. Seewald referring to the Russians from the Soviet occupying force or is she thinking of the Russian prisoners of war that were in the Nazi system? Even if we are unable to answer all of these questions in the following, they are nonetheless worth asking. They suggest uncertainties, assumptions and fantasies that could perhaps affect the children and grandchildren of this family.

In response to the interviewer's question about what she herself experienced under the Soviet occupying force, Mrs. Seewald skirts the issue of her own experiences in the hospital. She mentions the rapes of her female relatives. She speaks of her sister, her sister-in-law and her thirteen year-old niece and then adds: *"Everyone that was here ((in the village, ed.)) They didn't even spare old women"*. With this statement, Anna is hinting that her mother was raped as well. But she does not want to talk about that. She states: *"...naturally I don't like talking about that, because I didn't experience it myself."*

We only find out what Anna experienced herself in this period through a few comments. The interviewer repeatedly asked her about the emotional strain her husband was under after his return from captivity. But Anna does not respond to this and eventually says: *"Well, I was imprisoned too for a*

*little while back then too.*" By revealing this part of her history, she avoids talking about the condition of her husband Hans Seewald, who developed symptoms of delusions of persecution in the post-war period that resulted in suffering for the whole family. When asked to say more about her own imprisonment, Anna corrects this, saying that she had to *"work under the Russians"* and had not been *"arrested"* or anything. What follows is a story that subsists on intimations. We find out that after capitulation, Anna worked for a few weeks in a hospital under the command of Soviet officers and doctors. We do not discover how Anna was released and how she came home: *"Well like a miracle I always managed to come home again and again through the grace of God. But I don't want to talk about that at all now."* The interviewer shows understanding for Anna: *"Because it was so hard for you."* Anna says again firmly: *"I don't want to talk about that."*

In a later sequence when the interviewer remarks in passing that Anna had remained in the hospital after the end of the war, the biographer suddenly says unexpectedly: *"And we were but afterwards we were loaded on to freight trains and we were supposed to be sent on—a transport to—, well to"*. Unskilfully, the interviewer now helps her in a direction that may have distracted Anna from what she experienced:

Interviewer: Siberia

Anna: doubtlessly to Russia or what do I know (1). But then I was very lucky indeed (2) if I'd have gone along on it I definitely wouldn't have come home again

Interviewer: Do you think they were killed

Anna: I haven't heard of any of them coming back from there ((starts to laugh)). I got a letter from someone who said the nurses were only there (1) as a means to an end for the Russian officers."

We can only deduce from this passage that Anna was not put on this transport or managed to escape a transport in time. What weighed on her at that time and what she does not want to speak about remains unclear. Let us turn now to Anna's husband. Hans Seewald<sup>188</sup> was born in 1914. He came from a very large family, too. Even as an adolescent, he had to work in a factory to support his parents financially. He completed the customary two years of military service, starting in 1935.<sup>189</sup> At the beginning of the war, Hans Seewald was initially sent to the Western front, but returned home after several months and

---

188 Hans Seewald was interviewed twice by Bettina Völter in 1993.

189 "Persons liable to military service born in 1914 were called up for physical examination in the period from early June to August 15 1935 and were enlisted to perform compulsory active service in autumn 1935 or autumn 1936. Those reservists who were released after completing compulsory military service in autumn 1936, 1937 or 1938 were generally called up again from August 26 1939 on." (Absolon 1960, p. 154).



according to his account worked in a factory that was essential to the war effort until March 1943. Inmates from the Sachsenhausen concentration camp were used in this factory, where his father worked then as well. Hans Seewald himself mentions encountering French and Polish forced labourers and concentration camp inmates every day.

Hans Seewald tells us that in 1943 he volunteered for military service because there was too much hunger in his homeland and the air raids were too dangerous. He joined the frontline troops on the Eastern front. His depiction of the years from 1943 to 1945 is decidedly fragmentary, and his statements of time and place are scanty and full of contradictions. This is all the more striking because Hans Seewald gives a very precise description of the circumstances surrounding his first conscription in 1939, the unit and the places he was stationed at. The few clues we are given, combined with our archive research, indicate that during the war he was stationed in places where it is very likely that he witnessed the genocide. After he signed up, his unit was sent into action in a city 300 km south of Moscow where *Einsatzgruppe B*<sup>190</sup> was also stationed at that point in time. Shortly afterwards, he witnessed the German *Wehrmacht* crushing the Warsaw ghetto uprising.

Hans Seewald presents himself as a combatant in the war who was only there *"as a visitor"*. He speaks of *"disgusting things"* that he heard about and argues that the SS and other units raged there but that he had *"just been there as a limited frontline soldier uh uh for short spells"*. Hans Seewald repeatedly addresses the theme of Nazi crimes by speaking of his brother-in-law and friend Gernot, Anna's sister's husband, who did not return from the Soviet POW camp. Hans Seewald assumes that he was sentenced as a war criminal in the Soviet Union because he took part in the mass shootings of Soviet prisoners of war and helped burn their bodies. Hans Seewald argues that his friend *"had"* to take part in this as a *"little soldier"*: *"As little soldiers they got orders that were murderous (I) and if you didn't follow them you were put up against the wall, you know, were shot, or hung on a tree, there were orders like that. And the little man he had to do it or his life was over too."*

Hans Seewald also speaks of himself as a *"little soldier"*, who was punished after the war while *"the big ones"* got away scot-free. An analysis of the sequential form of the interview text permits the assumption that in the passages where he speaks of his friend Gernot, the biographer is indirectly speaking of deeds in which he himself was implicated. Voicing the theme of wrongs committed by the biographer himself by telling stories about other people, i.e. talking about others, is one strategy of denying but at the same time admitting crimes. This strategy was one we repeatedly observed in other interviews (cf. Rosenthal 1995d). In response to the question of what he him-

---

190 Einsatzgruppen or special-duty groups were mobile killing units which accompanied the *Wehrmacht* into the countries it invaded from the March 1938 invasion of Austria onward (Krausnick 1985).

self experienced in connection with the annihilation of the Jews, Hans Seewald tells us of the crushing of the Warsaw ghetto uprising in spring of 1943. Our archive research confirms that the biographer was admitted to a Warsaw reserve hospital in mid-May. Hans Seewald recalls that: "*The Germans somehow destroyed the Jewish ghetto there before that.*"

After this brief remark about a "*somehow*"-destruction of the ghetto which does not refer to any victims, Mr. Seewald describes himself as a victim of a Soviet air raid, which - he speculates - "*Yankees*" were perhaps involved in. He says the Allies "*took revenge*" for the crushing of the ghetto uprising: "*And I lay there in the hospital and the next night then they bombed the hospital, the Russians and I don't know if the Yankees were involved in it. But we really experienced something there, I can tell you.*" At this point in the text, there follows a detailed description of this bombing.

Why does the biographer have this conspicuous need to present himself as a victim? Let us examine in more detail his attempts to exonerate himself in the way he argues. Like his wife Anna, Hans Seewald also explains his enthusiasm for National Socialism through the change in the economic situation that it brought to his family. He presents himself as someone who comes from "*the little classes*". In his stories, he appears as a victim of circumstance, a victim of accidents or air raids. For him, this self-portrait is closely linked to the state of ignorance and innocence which he attributes to himself. The argument, that the "*little people*" were helplessly at the mercy of what the "*leadership*" decided, pervades the entire interview. This argumentation takes its most incisive form in Mr. Seewald's remarks about the persecution and murder of the Jewish population. In his opinion, the real guilty parties behind Germany's disastrous defeat and the annihilation of the Jews were "*the international world capitalists*" and the "*Jews in leading positions*". Hans Seewald claims that the director of the arms factories, where he and thousands of forced labourers worked during the Nazi period, was a Jew, too. He explains that:

Mr. Seewald: "Hitler was just a straw man, a puppet of the capitalists. (...) You see under Hitler we had Jews in leading positions too ... These high-ranking Jews and the people who all went to England and America because they were Jews, - why didn't they help their little people? And the little German (1) what they did there (1) with the Jews that was well (1) not normal (1). And I assume that didn't all originate with the Germans alone either. We Germans for our part wouldn't have done that. These orders that were given, were from people who sat in the background who gave the orders to those down below."

Interviewer: "And who do you think it was in the background?"

Mr. Seewald: "The big capitalists. The international world capitalists."

Mr. Seewald presents himself as someone who as a simple soldier in the Nazi period did not give orders, and thus as someone who is not guilty in this respect. On the contrary, the "*murderous orders*" that his brother-in-law Gernot and perhaps he himself followed were given by the "*international world capitalists*". With his argumentation about the "*big capitalists*", this biographer is using one of the concepts of history prevalent in former East Germany which blamed "imperialism", in Lenin's words "the era of financial capitalists and monopolies", for handing over power to "fascism" and regarded Hitler as a "marionette of the capitalists". However, by equating "*the leadership*" and "*the Jews*", Hans Seewald is turning this anti-capitalist view of history into an argumentational figure that is anti-Semitic and falsifies history. Now the Germans no longer appear to be the guilty ones behind the annihilation of the Jews, but rather the Jews themselves.<sup>191</sup> The "*murderous orders*" which the "*little soldier*" received are one of the key themes in the family interview. It emerged in this context that blaming the Jews, something his wife does as well, is connected to following these orders. An analysis of the family interview (cf. Chapter 6.3) makes it clear that a family secret is concealed behind this theme.

Another of the Seewald grandparents' secrets is the mysterious death of Hans Seewald's father. His daughter Mechthild, with whom we conducted the first interview in the family, told us about this. In 1955, when Mechthild was five years old, her grandfather, Hans Seewald's father, was found dead in a river. The family interprets this as a "*mysterious*" incident. Had he been mistaken for someone else? Was the East German secret service behind it? Did the murder have something to do with the Soviet occupying force? Was it perhaps an act of revenge by a former victim? His death has still not been solved. In the period following the discovery of his dead father, Hans Seewald was seized with a panic that had paranoid tendencies. The way Mechthild remembers it is that at his instigation the family had to hide in the nearby forest every night for weeks because he was afraid of being arrested or murdered himself. Mr. Seewald's rather irrational behaviour suggests the assumption that he expected to be punished or made accountable himself and also interpreted his father's death in this light. This suggests a possible connection between two secrets: perhaps Hans Seewald's father followed murderous orders and, so the fantasy shared by Hans and his family, was murdered for this reason? Perhaps Mr. Seewald was afraid a similar fate awaited him?

---

191 But in a grotesque way, perhaps this absurd misconstruction is to a certain degree modelled on the anti-Zionist and anti-Jewish arguments of the Communist party of the Soviet Union and the SED in the early 50s. At that time all Zionist organizations were considered vassals of US imperialism which exclusively served the interests of the capitalists (cf. Diehl 1993). Seewald appears to couple the theory of fascism and anti-Zionism for his purposes of argumentation.

In any case, the unsolved death of his father continues to make him afraid today. Only after being asked by the interviewer about the death of his father does Mr. Seewald speak about the alleged murder, but refuses to go into detail. He says one can *"think about it but not say anything, not even nowadays."* Although since the changes of 1989, it is now possible to do research in previously inaccessible archives<sup>192</sup> and their daughter Mechthild has offered to take on this research work, the Seewald grandparents do not wish to pursue the matter any further. Mechthild mentions that she could not get through her mother's *"fear barrier"*. Hans Seewald justifies his hesitation by saying that the *"evildoer"* is perhaps having *"a few peaceful hours"* today. Is he afraid of disturbing the *"evildoer's"* peace? Could the *"evildoer"* perhaps reveal something that worries Mr. Seewald?

The grandparents Anna and Hans Seewald present themselves as *"little people"* who had to bear the consequences of what *"the big ones"*, who include *"the Jews"*, got them into. In doing so, they attribute the role of perpetrator to the victims and those persecuted by National Socialism, while implicitly making themselves out to be the victims of the victims. The changed social conditions since the fall of the Wall, the withdrawal of the Soviet armed forces and the expanded opportunities for research neither help air the secret surrounding the death, murder or suicide of Hans Seewald's father, nor help explain Anna Seewald's *"fear of the Russians"*. We assume that this has to do with the fact that naming the facts would lead to other secrets being revealed which they do not wish to be discovered. What impact does the grandparents' past and their secrets have on the descendants in this family?

### *The daughter Mechthild: a mystical fear of corpses*

The daughter Mechthild<sup>193</sup> was born in 1950. She grew up in a closely-knit family system and we can presume that her family ties only became somewhat looser when she moved from her house on her parents' property to a neighbouring village and later to Thuringia, after she was already married and had two children. Like her parents, Mechthild was a member of the Evangelical Church under the East German regime and she refused to join the Socialist youth organizations. Due to her especially good performance at school and the opportunities for career mobility still available for her birth cohort in East Germany, she managed to get a place at university anyway. She is currently a practising doctor at a large hospital in Erfurt, in central Eastern Germany.

When Mechthild talks about her family history, she speaks primarily of the poverty of her ancestors. Initially she only speaks of her mother's family,

---

192 Such as archives containing files kept on individuals by the East German secret service, the Stasi, among others.

193 Mechthild was interviewed by Gabriele Rosenthal and Bettina Völter in 1993.

of their relief as Hitler "*brought a better life*" and of their suffering in World War II. She addresses the theme of her family history after 1945 by talking about the time her father spent as a prisoner of war in the Soviet Union. Thus, she does not initially mention the phase of his life when he was an active agent of National Socialism, but rather presents him exclusively in the role of prisoner of war. By doing so, Mechthild condenses her family history down to her parents' suffering and emphasizes her mother's and father's roles as victims. What is also striking is that she shifts experiences that her father told us happened during the war, to the period when he was a prisoner of war. Mechthild tells us that while he was a POW in Russia, he nearly became the victim of a mass shooting of German prisoners of war:

*"German prisoners of war were shot by Russians en masse in the camp there (2) well that he managed to get out of there alive. Every morning they were selected for a forced labour team and he was actually supposed to go woodcutting but through some circumstance ended up in another team and then he saw from a distance how the ones who were assigned over there were shot."*

Mechthild reflects: "I don't even know now if that's at all true, but that's the way the story goes."

At another point, she mentions that her son-in-law claims that the incident could not have happened that way. Thus, even she is not so certain that this story really took place when her father was a prisoner of war or - our addition, now - whether it might have happened during the war.

Mechthild is making a temporal shift by detaching her father's experiences from the war period and shifting them into the post-war period. In doing so, she is going a step further than the Seewald grandparents who tell their experiences in the appropriate historical context. Even when asked by the interviewers about his experiences as a prisoner of war, Mr. Seewald says nothing at all about any such shootings. For him, shootings are far more a theme in connection with crimes committed by the Germans. On the other hand, we discover nothing about these crimes in Mechthild's interview. Rather, she refers to her father having "*never said anything about the war*" and says it is only now that he "*sometimes speaks very tentatively*" about what he experienced in captivity. Thus, her parents' fears of "*the Russians*", which are sometimes only latently addressed as a theme, become concrete stories for Mechthild. The fantasy that her father only narrowly escaped death gives Mechthild the feeling that she has to protect her father from his memories of this period and forbids her to ask him about it.

However, Mechthild also used the interview situation to address some of the taboos in her family. She hoped the interviews would give her parents emotional relief. At the same time she was very worried about whether touching on certain taboo areas might excessively upset Anna and Hans Seewald.

This ambivalence between the desire to address taboos and at the same time maintain the silence around them made Mechthild a mediator between her parents and us, trying to make us understand their perspective. On the one hand, she hoped our questions would make her parents talk; on the other, she wanted to protect them from our questions. Mechthild asked us to treat her parents as carefully as possible if themes came up that were loaded for them. She added that where her mother was concerned, this applied to her experiences as a nurse at the military hospital: *"I'm sure you'll have to be very careful with her when you get to this theme."*

Mechthild herself has the images of very badly wounded soldiers in her mind's eye and even imagines that her son could have been one of them. In contrast, Anna Seewald argues in the interview that by that time she had long *"grown used"* to death, and that the only thing that was hard for her was the sight of her first dead person, an old woman who died during her training period. Whereas Anna does not want to talk about her return home from the hospital, Mechthild tells a story about it:

*"When the war was over, she was supposed to have been put on a (1) Russian transport evidently going to Siberia. And then somewhere along the line when the train slowed down she jumped out of the train (1) and she walked as if she were driven umpteen kilometres fifty kilometres or something home (1) and when she came home my grandmother, who had evidently been waiting for her, died in her arms, probably of a heart attack."*

The differences between Anna and Mechthild's representations suggest that both the transport and the death of Anna's mother, here portrayed as occurring in connection with Anna's return, are linked to something problematic that belongs to Anna's secrets.

Mechthild also told us about her grandfather's *"mysterious death"*. She feared that her mother would be *"horrificed"* if she knew her daughter had revealed this taboo theme that was so loaded with fear. But she decided to inform us nonetheless to prepare us for the interview with her father: *"I think it's very important to understand father a bit."* Mechthild explains her father's fears that led to weeks of the family hiding in the woods at night, with his experiences as a prisoner of war: *"then I guess all these Siberia fears came up again."* We interpreters also assume that Hans Seewald's fears are a reactivation of other fears, which we believe relate to experiences during wartime and could be connected to a fear of the victims' revenge. But Hans Seewald and his family remove the origin of his fear from their perception and thus shift it to other objects.<sup>194</sup>

Fear, death and corpses are themes that run through Mechthild's own life history and her life story. She has encountered these themes from her earliest

---

194 For more on the shifting of fear, cf. Mentzos 1944, p. 14

childhood. For example, we discover that she often found her father's bed *"wet with a cold sweat of fear"* when she got into bed with her mother in the morning after her father was already up. Being woken up at night and hiding in the woods after her grandfather's death is something Mechthild still remembers as a *"bad time"*. Her mother shared her fears with her as well. In the years that followed the death of her paternal grandfather, several other close relatives died, including her mother's brother, who died in an accident. Anna Seewald went to the mortuary to see his mutilated corpse and could not get the image out of her mind: *"...and then she was terribly afraid, like at the cemetery, she had a really mystical fear. She was always looking to see whether the ghosts were coming now and getting hold of her skirt."*

Mechthild mentions that her mother regularly took her along to the cemetery to protect her from the ghosts. "Fear, death and corpses" are also themes that Mechthild linked with the genocide and fear of the Russians even when she was a child. It is striking that both in the interview with Mechthild and in the one with her daughter Petra, the neighbouring woods are always mentioned in connection with these themes. In the Seewald family, this wood is depicted as a place of shelter, safety and the fairytales about the animal family adventures that the grandfather Hans Seewald told his daughter and later his grandchildren. But it is also a place of fear of death. Even as a child, Mechthild knew that there were mass graves next to her *"fairy tale woods"*. For Mechthild, these graves are places from her childhood where you were not allowed to play, places of horror that no one in the family spoke of: *"Well I felt the horror physically even as a child ((takes a deep breath)) and now, there, if you go through the woods towards the back, well there's a place in the woods where you start to get this feeling of horror."*

Thematically, she links this *"feeling of horror"* with a *"mystical fear"* of death and corpses. Even as a child, she acted out this theme of death. When she was playing in the woods, Mechthild tried to dig down to the groundwater: *"And I always thought if we get down to the groundwater we might drown. Yes, there was always a tingling feeling that went with it."*

Presumably Mechthild's fear is motivated by the mysterious death of her grandfather, whose dead body was pulled out of the water when Mechthild was five years old. But her fear is also quite obviously related to the genocide. However, this theme is only explicitly introduced at the end of the interview by the interviewers. In response to the question of what it was like for her to live near the former concentration camp, Mechthild asserts that she *"doesn't constantly"* think about it. She goes on to describe the *"images"* that come to her in this connection. In her chain of association, she again links the themes of "fear", "death" and "corpses". Let us look at these images or scenes in the sequential order in which Mechthild mentions them in the interview: she first talks about her mother. Mechthild describes how she pictures her mother working at a company near the entrance to the concentration camp.

She imagines how, when she and her colleagues came out of the door to give pitying looks to the inmates marching past, the accompanying guards warned them: *"You can go straight to the back of the line with the others if you don't go inside right now."* She pictures them obeying out of fear. Then Mechthild remembers the *"piles of corpses"* in films that she was shown as a schoolgirl when they visited concentration camps. Finally, her linking of the themes "fear and corpses" is rounded off in the third sequence which focuses on the theme: "fear of corpses". Mechthild describes a situation that she experienced as a student. One evening, she got lost and ended up in the basement of the forensic medicine department, where the bodies of people who had died in fires or drowned, in various stages of decomposition, were exhibited in display cases. Plagued by extreme fear of not being able to find her way out of the building, she panicked. She says that she still feels *"mystical fears"* when she thinks about it even today and that she still repeatedly imagines that she cannot find her way out. Mechthild is afraid of being trapped in with the corpses or not being able to get away from the sight of them. The metaphor that she uses to evaluate this experience is fitting; she says that this memory was just as *"buried"* as her memory of how she used to play in the woods next to a *"mass grave"* as a child: *"I knew exactly there's this mass grave there and that was completely taboo, we children knew from our parents that you don't step on them: 'there's a mass grave there, don't you go over there', we knew exactly, up to the trees roughly there's the mass grave and we didn't gather blueberries over there."* Today she believes that the place she was not allowed to go to is where the dead from the internment camp run by the Soviet Military Administration are buried.

For Mechthild, the psychological consequences of her family history are mainly her incomprehensible fears, especially her fear of corpses although these also seem to hold a certain attraction for her. Mechthild seems fascinated by the taboo of "coming into contact" with buried people who died a violent death, and at the same time she is afraid of such contact. On the one hand, in a figurative sense, she wants to dig for those who were murdered, but on the other, she does not want to find the corpses. She does not try to see if any connection can be made between her fears and the past of her grandfather who was found dead and of her parents during the Nazi period. Like Eberhard Sonntag (cf. Chapter 5.2), Mechthild avoids the question of her parents' active deeds in this period. Like Eberhard, who tortures himself with the question of whether he would be capable of shooting children and women, Mechthild wrangles with herself for being unfaithful to her pacifistic ideals and being prepared to shoot during her premilitary training. At the beginning of the interview, she states: *"I was really brought up on a kind of pacifistic mother's milk."* She argues that despite being a prisoner of war, her father did not develop *"a hatred of Russians"*, but *"always said"* that war was *"instigated"* from above. But she says that he - like her mother - *"lacked the cour-*



age" to "let himself get shot for it." Mechthild is clearly thinking of the repercussions of refusing to carry out orders as a consequence of a pacifistic stance.<sup>195</sup>

But Mechthild found it impossible to reconcile this pacifistic upbringing with the East German regime's demands on a university student. Her parents' anti-war message collided with their delegation to their daughter to change her status of "little people" and have a successful career. A conflict therefore arose during Mechthild's years at university when she - like all the other students - had to go through premilitary training. At first she refused to shoot. But in the end, she gave in because they threatened to expel her from university: "That was a very bad time this decision, and then I did shoot and always carried these cartridge shells around in my pocket for such a long time ((laughs)) and I felt absolutely miserable (2)."

Mechthild tells this experience of her own powerlessness as the dramatic climax of her biographical self-presentation. She says her decision to shoot after all still tortures her today, adding that she guesses the fear she felt then and the social pressure she was under were similar to what her parents experienced under National Socialism:

*"I could also somehow reconstruct how my parents might have felt at certain points then, whereas as a very young person (1) I didn't (1) make allowances and always said: 'How how could you have allowed that with the Nazis to happen' and: 'If you don't want something, then you don't do it.' And so I became a bit more humane through this experience back then. Although there are still themes today, um (1), that we just don't talk about any more."*

While still a student, Mechthild married a biologist whose father had been a pastor during National Socialism and a member of the "Confessional Church", a movement within the Protestant Church that was in opposition to the "German Christians" and opposed the Nazi's claim to power. Mechthild and her husband have two children - both grown-up now - Petra (born in 1971) and Matthias (born in 1976).

---

195 So far it has not been possible "to find proof of any case of someone given an order suffering bodily or other harm by refusing or failing to carry out a criminal order" (Jäger 1982, p. 158). Besides the cases that Jäger discusses, Browning's study (1992) also indicates that, on the contrary, members of a police battalion were actually exempted from taking part in massacres.

*The granddaughter Petra: "I'm very insecure and afraid of many things"*

Petra<sup>196</sup> was born prematurely in 1971. From a medical point of view, her chances of survival were slim. The baby lay in an incubator for weeks. Mechthild and her husband phoned the hospital regularly to inquire about their daughter's state of health. Miraculously, the child survived without even suffering any damage to her health. During this period, Petra's parents had to cope with their helplessness and the likely death of their little daughter. While Mechthild still feels a "very deep relationship" to her daughter today that she says has "doubtlessly often prevented" her from giving her daughter the space she desired, Petra describes her relationship to her mother as disturbed:

*"I still haven't forgiven my mother for that today, I mean that she somehow stuck me in the hospital there. Well in my subconscious it comes up again and again ((takes a deep breath)) (2). And that was reinforced because I had at ((takes a deep breath)) the age of four- I had a metabolic disorder or something=and so then I had to go ((Petra increasingly begins to stutter)) into- to the hospital and then ca-, that th-, that time I was con- consciously involved... and that's why that is because of these experiences actually the relationship I=have to my mother but=uh, until=l, I=I moved away from home uh- a ((takes a deep breath)) (1) well a distan- a distant relationship well `none', well I can't say it's a good one."*

While Petra places her grandmother very close to her in her family sculpture, her mother is assigned a place on the edge of the sculpture. In addition, her mother, like three other negatively cathected people, is depicted in the colour yellow. She allocates the colour green to her grandmother, and to all the people she feels safe with. She also makes it explicit that for her, green is the colour of safeness and is linked with the green of the woods. People she is afraid of, including her grandfather Seewald, her father and her husband Frank are depicted in red. Petra feels very drawn to her grandmother Anna. She says that her grandmother created a "protective field" around her and gave her "all her love" because she herself had been threatened by a near-fatal illness as a child. Petra's parents were still students, when their daughter was born, and later both of them worked. Petra's close relationship to her grandparents, on whose property the young family lived at that time, stems from this period. In contrast, the distance to her mother grew deeper. Her grandmother Anna looked after her during the day. Hans Seewald also spent a

---

196 Petra was interviewed twice in 1993 by Gabriele Rosenthal. While she was quite willing to be interviewed, her brother and her father were not.

lot of time looking after his granddaughter. He often went with her into the nearby woods, which Petra calls the "*fairytale woods*". Her grandfather told her animal stories. They built a little cabin and as a seven-year-old, Petra wanted to sleep overnight in it alone. Her grandparents, however, were afraid she would be "*snatched away*". Thus, like their daughter Mechthild, their granddaughter also formed a link between the themes of "safeness and fear". We interpreters think of the green of the woods and the red that symbolizes fear in this context.

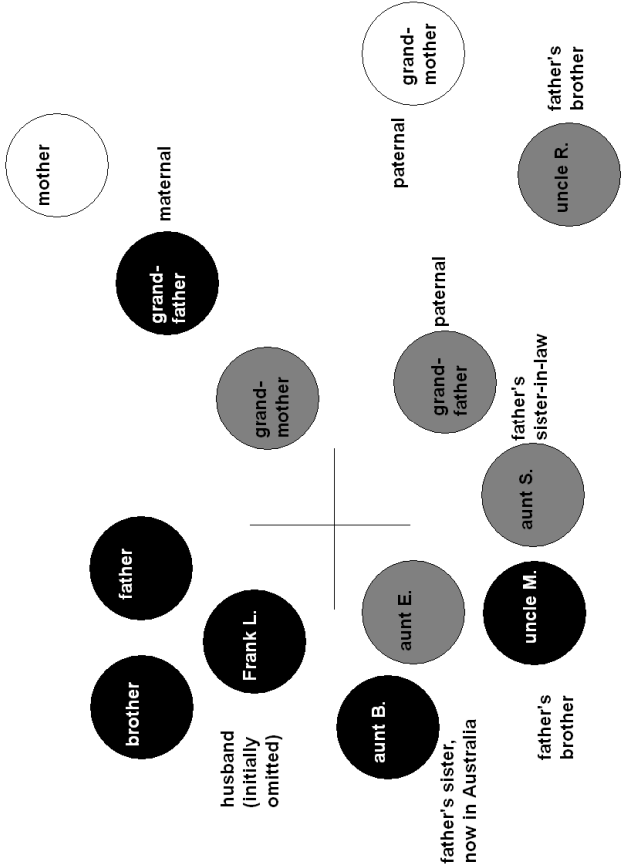

Figure 4: Petra's family sculpture

Petra identifies with her grandmother Anna, whom she imagines was a very timid girl who was far from independent. Petra talks about her own childhood and adolescence from the point of view of her fearfulness and her constant attempts to stand her ground. She says that her grandmother did not raise her to be independent and that she was always an outsider among her peers. Petra remembers that she did not go to day-care until she was three years old, but that every morning she was "*terribly afraid*" and cried bitterly on the way there. Another situation that occurred during her school years is still so much with her that she gets a stomachache even today when she thinks about it. In third grade, Petra's class was learning to swim in physical education. She was afraid of the deep water and refused to do a header into the pool. The swimming instructor threw her in, and the eight-year-old had the feeling that she was going to drown. She describes this as a "*traumatic experience*" that haunts her in her dreams to this day:

*"I have- well I see it still today I sometimes dream about it too, that ((very animatedly)) only ((takes a deep breath)) green water around me and I couldn't breathe just air bubbles rising up well because everything became blurred ((takes a deep breath)) I only paddled up with my arms, had water everywhere in my lungs- in in in my mouth in my throat in in in well in my eyes in my nose, in my ears (1) ... Then I was pulled out more dead than alive."*

Does this fear of drowning in green water reveal traces of Petra's traumatic birth? Or is this fantasy and fear linked with the family secrets, with the corpses in the (green) woods or with the drowning of her great-grandfather Seewald? Whereas in her own childhood, Mechthild tried to dig down to the groundwater and felt a certain fascination in the thought of drowning, Petra is mainly "terribly afraid" of drowning herself. Whereas the mother is afraid of corpses (people who drowned), the daughter feels in danger of being pulled out of the green water dead.

Unlike her mother, Petra is a young woman who seemed to us interviewees quite fearful. Petra herself asserted that she was afraid of her life "*coming to nothing*" and constantly fought against "*giving up her personality*". She said she was afraid of failing careerwise and worried a lot about her future.

In deciding to learn a craft trade after tenth grade, Petra was acting in a certain opposition to her mother. After the changes of 1989, Petra went on to finish secondary school and is currently studying humanities at a university in Thuringia. Petra said that she felt her course did not really satisfy her, however, and that her dream was to work artistically and become famous.

In her story, Petra repeatedly emphasizes situations where she has succeeded in asserting her own will. Unlike her mother, she was a member of the Socialist children's and youth organization, the FDJ, in her school years. In contrast to her mother, Petra emphasizes that "*up to a certain limit*" she was

able to state her political opinions during her school years. However, she did not graduate from either secondary school or university under the East German regime, which would presumably have demanded greater political concessions.

Today, Mechthild evaluates herself as a "*very domineering*" mother in relation to her daughter. She says that Petra had to fight for her independence, and that in the process she revolted against everything that she herself thought was an important life maxim. Petra explains that it was just important to her to work with her hands. But then during her training, she often suffered from "*feelings of inferiority*" either because she did not work quickly enough or because in the eyes of her trainers she did not carry out the tasks assigned to her correctly. Even today, Petra is afraid of not being able to muster up enough endurance to learn a profession that would completely engross her. We can interpret Petra's training history and her recurrent insecurities about her professional career against the background of her mother's career. Presumably her fears of failure are partly the psychological price of her mother's rapid social rise, which Mechthild had to put a great deal of energy into achieving. Petra's own suffering as a result of the limited amount of time her successful mother had for her contributes to her somewhat negative response to Mechthild's expectations that her daughter maintain what she has achieved by succeeding in a career of her own.

Her political orientation and her early marriage are among her attempts to develop independently of her family. During the period of political changes in 1989/1990, Petra began to get interested in East Germany's declining Socialist Unity Party and its successor, the Party of Democratic Socialism or PDS. She was nineteen when she met her future husband Frank, who at the time was still a major in the East German National People's Army (NVA), an officer cadet and a convinced party member. When the NVA was dissolved in 1990, he became unemployed. In the interview, he asserted that his political convictions had not permitted him to be taken on by the (former West) German Federal Armed Forces. Frank is thirteen years older than Petra. The couple married in 1991 and in the same year, Petra joined the PDS. Petra's choice of partner and decision to join the PDS provoked her entire family, who under the East German regime had tried to evade political commitment to the East German state. Petra asserts that she felt safer in East Germany than she does under the new system: "*after school I was guaranteed a teaching position ...people didn't fight against each other.*"

However, she says her main motivation for joining the PDS was an impulse to support the party's leading figures, who had taken on responsibility for the past, against attacks in the Western German press and criticism from within her family. Petra found Gregor Gysi, the party chairman of the PDS, particularly "*worth protecting*":

*"He's had a lot of attacks (1) because he also had a Jewish background. For example in Spiegel<sup>197</sup> this article "The man pulling the strings" ((takes a deep breath)) I thought it was so unpitiful the way they exposed him. And because he's so small in stature I felt I had to somehow protect him."*

The theme of "Jews" also occupies Petra in connection with her husband Frank. Without being able to say the word "Jew", she asserts that Frank may have *"this family background"* because he looks like all *"the others"* she knows. It becomes clear from the context that Petra means "other Jews". This characterization is all the more striking when she describes her husband and his father as people she is afraid of:

*"They both radiate tremendous authoritative power ... and with Frank it's when he acts like his father just sits there and says nothing and threatens to take steps of some kind. I'm always afraid too of him somehow going away or something, like if I do something not right."*

Petra describes the difficulties she has living with her significantly older partner. She says that because he is unemployed, he does not have much to do, that he controls her daily life, always insists that he's right and blocks her independence. Reading between the lines, it becomes clear that Frank suffers from a severe alcohol problem and has beaten his wife. Now what connection does this have to Petra's sense that her husband looks Jewish? For Petra, "Jews" are, on one hand, "victims worth protecting" but, on the other, perhaps also people with aggressions that they let out on her. Petra also finds it hard when her husband gets into heated discussions with her grandfather Hans Seewald. At a number of family gatherings, Frank has criticized her grandfather's willingness to obey orders in particular and his version that you were *"put up against the wall"* if you did not *"join in"*. He also calls into question the story of the grandparents' suffering at the hands of *"the Russians"*. When during one visit, Frank asked her grandfather how as a Christian he could justify taking part in the war, Hans Seewald broke off the conversation. After that, whenever a meeting with Petra and her husband was planned, her grandfather developed kidney trouble. Petra explains that this is a disorder that he acquired when he was a prisoner of war. She says that she feels torn between the two of them when they fight, and that she understands both her husband's position and her grandfather's. Thus, she sometimes sides with one of the men and sometimes with the other. But she feels that both men are a danger to her, as her use of the colour red in the family sculpture expresses.

Petra also employs the strategies of deferring incrimination used by her grandparents and her mother: the indicative strategy in Mechthild's case of a "victim-perpetrator-inversion" that makes victims of the perpetrators, finds its

---

197 "Der Spiegel" is a Western German weekly magazine.

clear continuation in Petra. Like her mother, she undertakes a temporal shift of her grandfather's experiences by presenting his experiences in the Soviet Union during the war - particularly his encounters with the Russian civilian population - as if they had taken place when he was a prisoner of war. By speaking about her grandfather almost exclusively as a prisoner of war, she presents him as a victim and glosses over the period when he was active as a soldier. The myth of the family's poverty also helps the granddaughter to explain her grandparents' enthusiasm for National Socialism. By focusing on the theme of "poverty", Petra initially avoids mentioning the family history between 1933 and 1945. In the questioning part of the interview as well, Petra portrays both grandparents as victims of the war: she says that her grandmother Anna is still afraid to talk about the National Socialist period because then she remembers the horrible images of wounded soldiers that she had to see as a hospital nurse. Petra also tells us that her grandmother was nearly sent to "*Sibiria*" at the end of the war. She "*jumped out of a moving train and walked home*". The granddaughter heard about this story from her mother Mechthild. She has never spoken about it with her grandmother.

Petra says that her grandfather portrayed his training period in the army in a very positive light in the discussions he had with her husband Frank, saying he was taught "*discipline and order*" there. But she adds that he was reluctant to go to war: "*He couldn't resist them or he would've been shot and he didn't want that (1). He refuses to accept being judged guilty.*"

While Petra sees her grandfather as "*not in the front row, he wasn't one of the ones shouting hurray*", but she secretly doubts whether he was forced to support the National Socialist regime and follow its orders. She gets particularly angry about her grandparents' assertion that as "*little people*", they could not put up any resistance to the prevailing social circumstances:

*"Through this experience (1) that is from the war as well I think (1), they think they can't do anything to change the way things are. Like that as little people ((takes a deep breath)) (1) they are always little candles and they just let things take their course and they can't change anything that's how it is, god-given".*

At first, we discover very little in the interview about the history of her paternal grandparents, who did not support the Nazi regime, although Petra could easily have used them as counterevidence to the stance taken by the Seewald grandparents. It is only when the interviewer specifically asks that Petra explains that her paternal grandfather was a member of the "Confessional Church" during the National Socialist period and that her grandmother dropped out of university because - in Petra's words - she disliked the National Socialist policies at the universities. But as Petra evidently does not identify with this part of the family, it barely plays a role in her biographical self-presentation. Instead, she explains that she has a very distant relationship

to these bourgeois grandparents. She says that while her maternal grandparents gave her "*goodness and openness towards people*", from her other grandparents and from her father she "*picked up critical thinking*". Does this side of the family and this critical thinking perhaps threaten Petra's attachment to the other side of the family? On the whole, Petra seems to fluctuate between reflecting critically on the Seewald family history in the Nazi period and veiling this past. This also emerges in her husband's paradoxical role in the process of her confronting her family history: on the one hand, he supports Petra by formulating in words the criticism and scepticism that Petra also feels toward the Nazi past of her Seewald grandparents, but on the other hand he puts her in the position of defending her grandparents.

What motive does Petra's husband Frank Lindner (born in 1958)<sup>198</sup> have for taking on the role of the sceptic and critic in his wife's family? What function does his behaviour toward the Seewald grandparents have for the family dialogue within his family of origin?

Frank's parents were both members of the Hitler Youth. During the war, his father served as a soldier on the Eastern front. He was badly wounded and spent some time in hospital in Germany towards the end of the war. During the last weeks of the war, he was sent to the Western front. Here, Mr. Lindner was taken captive and put in an American POW camp. After his release, he returned to his hometown in East Germany. He became a *Neulehrer*<sup>199</sup>, a "new teacher", and moved to a village in Oderbruch, an area along the Polish border. Frank's mother grew up in a village near the Buchenwald concentration camp. After 1945, this camp was also used by the Soviet occupying force as an internment camp. Mrs. Lindner's father was imprisoned here from 1945 to 1946. He died before his release. Frank's mother was also a *Neulehrerin* in Oderbruch. Like her husband, she joined the SED party as early as the end of the 40s.

Frank Lindner tells us that he only found out his parents were members of the Hitler Youth by accident, when he was perusing his father's documents looking for some other information. He said he had been shocked because his family had only ever talked about his father getting wounded and the inhumane conditions in the American POW camp. The internment of his maternal grandfather in Buchenwald was also a family secret until after the changes of 1989. It was only through research done by one of his uncles that this story came out. In the Seewald family, Frank had initially argued that the inmates

---

198 Bettina Völter interviewed Frank Lindner twice in 1993.

199 In the wake of de-Nazification in the Soviet-occupied zone, teachers who had belonged to the NSDAP or were implicated in Nazi crimes were replaced by "Neulehrer", or new teachers. These were generally young people, often former members of the Hitler Youth, men returning from POW camps, and unemployed people. Thousands of them were trained as teachers in crash courses and in the years that followed, they were seen as having loyally helped to build a new society.



who died in "Special Camp Nr. 7" in Sachsenhausen were justly punished by the Soviet occupying force: now he was forced to think things embedthrough again, for his maternal grandfather is said to have been a small bank clerk who was arrested despite his innocence.

For many years, the horizon of Frank Lindner's family history only went back as far as 1945. He grew up in a family where East German ideals were largely passed on uncritically. When he decided as an adolescent to aspire to a career in the National People's Army, which meant that he could go to secondary school and get a high-school diploma, his parent's supported him unreservedly. During this period, when Frank was thirteen years old, his mother became ill with cancer. She died five years later, during Frank's high-school examination period. He repeatedly argues in the interview that without the support and discipline of the army he would not have successfully passed either his high-school final exams or his course at the Officer's Academy. Because he had enlisted before he finished school, the army supported him during his final years at secondary school. Around the time of his mother's death, Frank had severe alcohol problems; these became acute again after he left the army in 1990.

In its narrative structure, Frank's biographical self-presentation resembles biographical interviews with other professional soldiers.<sup>200</sup> Like them, this NVA major needs an institutional framework to embed his life story in. Frank Lindner presents his childhood and youth in the context of his family story. The incidents from his early adulthood that he relates are oriented on social events like party congresses or "East Germany's birthdays" on October 7th. One of the few situations that Frank tells us about the time he spent in the army is when he was forced to join the SED in 1979. At first, he refused and today he feels that he should have stuck to his "no" at that time, but his superiors threatened him by saying that he could not become an officer if he refused to join. Today, he is embarrassed that he gave in to them. He says that in general his superiors formulated their goal as being "*breaking the will of the soldiers*". He adds that he normally thought this approach was right. Frank Lindner tells his life story after he left the army as the story of his marriage to Petra and his disputes with her family. It is striking that he picks fights with grandfather Seewald about themes that specifically concern him, too. Without calling into question his own willingness to obey orders in his disputes with Mr. Seewald, he criticizes the latter for his "*credulity*" under National Socialism. But Frank tells us that even today, he only talks about the early phases of the East German state with his own father. He says that his father became ill when the Wall came down and that after the demise of the East German state, he felt "*betrayed twice*". His father argues that by using "*big words*", they first got him to believe in the National Socialists and then in the Communists.

---

200 Cf. the case analysis in Völter 1996.

Mr. Lindner says that he supported both systems and both of them collapsed. Due to the early death of his mother, Frank can only go into her family history indirectly.

It emerges that the biographer provokes disputes with the Seewald grandparents as a substitute for the lack of dialogue on the Nazi period in his family of origin. By doing so, he succeeds on one hand in distracting attention from the social devaluation of his biography and, on the other, in vicariously conducting a dialogue that was actualized in his family by the changes in 1989 but which it does not seem possible to conduct there.

Part 6:  
Two family dialogues compared



## 19. Veiling and denying

Gabriele Rosenthal

Preliminary remarks

In the following, we shall compare the family dialogues of the Goldstern and Seewald families and examine the differences in how families of survivors and families of Nazi perpetrators deal with the family past. In the case of the Goldstern family, we see how an attempt is made to lessen the helplessness suffered during the Shoah by establishing the family myth of the heroic fighter and how, among other topics, the theme of having witnessed the murder of small children in the Lodz ghetto is evaded. In contrast to the Goldsterns, the Seewald family has established the myth of „We are victims of history“. This myth covers up the secret of how much the family is implicated in the Nazi crimes. How do the two families speak about the past in the inter-familial dialogue?

### *The Goldstern Family: The threatening terrain of the past*

The family interview was conducted by Tamar Zilberman, the Israeli colleague, and by the author; jointly they interviewed the grandmother Lena, the grandfather Amos, and their son Joel. Joel took the initiative for the family to be interviewed, wanting to open up the family dialogue. The analysis of the interview shows, however, that every participant expected someone else to take the initiative, at the same time fearing what the dialogue might lead to. Joel delivered veritable "propaganda speeches" stressing the importance of the future and claiming it would be preferable to remain silent about the past. His father obstructed the dialogue. Repeatedly, he accused his son of lack of interest and actually manoeuvred him into this position; but he primarily attempted to keep the mother from talking. Everyone was afraid that by bringing up the past, he or she would put a burden on other family members. Amos and Lena, on the one hand, wish to talk about the past with their sons, now that they are grown up; on the other hand, they want to spare them the experience of learning about their family's history. Their son wants to talk to his parents, but is afraid this might be too much of a burden for them. A number of excerpts from the family interview indicate, however, that Lena would like to talk about her persecution experiences but needs support if she is to do this. The difficulty of establishing a dialogue in this family showed up during the

family interview as soon as the question arose about which language to communicate in for the interview. At the time we set the date for it with Amos and Leah, Amos informed us that the interview would have to be conducted in English, since his son knew no German and I no Hebrew. At the beginning of the interview, Joel, whose business takes him to Germany quite regularly, stated that he was capable of getting along in German. His father then denied that his son would be able to do so. Since my Israeli colleague does not speak German, we first tried to conduct the interview in English, but this resulted in a constant switching between languages. The father insisted on speaking English most of the time, the mother answered most of the time in German and sometimes in Polish, while the son switched back and forth between English and Hebrew.

The difficulties caused by this constant switching between languages are indicated by a special alphabetical "key" in the following dialogue quotations. Sentences preceded by an [E] were spoken in English, those by a [G] in German, those by an [H] in Hebrew, those by a [Y] in Yiddish, and those by a [P] in Polish. Marking the language in which each statement has been made is important, because the language chosen indicates to whom the statement is primarily addressed. In this context, it is important to keep in mind that I, a non-Jewish German, was the person being addressed during most of the dialogue. Survivors sometimes find it easier to talk about their traumatic experiences when the listener is German; in this case they feel less of an obligation to avoid putting the onus on that person of having to listen to a narration of the horrors the survivors had experienced. In the analysis of the interview, we took pains to examine the effects of the interaction between interviewers and interviewees. Thus it became possible to concentrate on the structure of the family dialogue and to describe those aspects that are critical for the purpose of a meaningful analysis.

The parents start out by talking about the fact that they have told their children the story of the persecution they suffered. The father then makes the following observation concerning his son, turning to me: "[G] I believe my son does not understand this; [E] I never talk about the Holocaust". The mother now remarks, also turning to me: "[G] I never have talked (3) about the Holocaust; that is in here". She touches her chest while uttering the last four words. I now ask the son: "[E] How is it for you to listen now to your parents?" To which he replies: "[E] I think it is my first time that I will - we sitting together and talking about the holocaust because it was let's say a see- see-." The mother completes his sentence saying: "[G] Taboo."

The son perhaps wanted to say "secret", but the mother completed his sentence by saying "Taboo." As Freud puts it "... thus 'taboo' has about it a sense of something unapproachable, and it is principally expressed in prohibitions and restrictions." (Freud, S.E., Vol. 13, p.71ff). While a taboo is expressed in prohibitions, a secret is not necessarily.

After we talk some more about the fact that Joel knows hardly anything about the persecution in his parents' past, I ask Lena if she would like to tell her son something about her experiences. She answers in the affirmative, the father gets up and, talking in staccato sentences, remarks that the mother has always been afraid when the sons were not at home. The mother now asks me if she should talk about the Holocaust, but the father interrupts her saying: "[E] *no, no you you have-*."

The son now tries to support his mother saying to her: "[H] *it's okay.*" But now the father stutters: "[E] *A from- a yes it was from the- I think so, you see, she have--.*" While he is saying this, the mother looks out of the window, though her gaze appears introspective. I ask her: "[E] *You have some images in your mind?*" The mother answers: "[G] *Sometimes I see there in front- I am, I am afraid, the automobile must not, everything everything I am afraid of everything.*" The mother talks on the manifest level about the present. Her response to my follow-up questions: "[G] *And what are you experiencing regarding the time you were in the ghetto? Do you have any picture of that in your mind's eye?*" makes clear the connection between her fears and the pictures of the past that she was remembering: "[G] *When it was forbidden to leave one's home, the children away from the parents, then I see ...[Y] and the children said mama don't give me away....[G] Babies old people my friend one threw them out of the window....she was sick, the flu....yes, that is what I see.*"

I ask the son: "[G] *Is it hard for you to hear this?*" He answers: "[E] *Of course it is difficult for me, hard and difficult to the....I prefer also not to ask not to hear..."*

Lena is talking about the 24-hour curfew during which children were taken from their parents. On the eve of our conversation, she had put her painful memories on paper and had these notes in front of her during the talk. Lena fidgets as she goes through these papers, signalling her desire that somebody ask her about them. After the conversation has been going on for about half an hour, I ask her if she wants to read to us from her notes. The father at first tries to prevent this; his main argument is that the notes are in Polish. This obstacle is finally overcome and Lena is able to start reading. She is able to do so thanks, mainly, to the support of her son who, contradicting his father's statement, repeatedly assures those present that he understands Polish and then remarks to his mother: "*(H) Read it to me in Polish; I understand every word of it.*" Repeatedly interrupted by the father, the mother then reads about one fourth of what she had written. She then stops and asks the son to translate it for my benefit. Let us now first consider the translation, including the son's commentary, before we turn to the original Polish text from which the mother had read:

*"(E) She is explaining me the main problem that-, or the feeling that they-, that she had (2) was ah the (2) that the Germans took the children.*

*They remember tough things that she remembers (2) very well (9) I think I can without having too much knowledge what's happened to them due to the fact that I saw the films and so on, I can imagine more or less what happened to them, and I think therefore I prefer not to hear too much because to be in a situation that I see, that I see them in a very bad reaction."*

It is largely because of Joel that the mother was able to read her memoir to us; he had insisted: "read it for my sake." We may assume that he was able to listen though he failed to translate the gist of what the mother read to us and thus kept her words from becoming spoken reality. We may assume that this reality lay present in the nine seconds of silence (indicated by the numeral 9 in the quotation), after which he continues that even without his parents talking about it, he could imagine "(E) *what happened to them.*" Like many other members of the second generation, he does confront what actually happened in the Shoah. He visited the former concentration camp where his mother, his grandmother, and one of his father's sisters had been imprisoned, and he suffered a nervous breakdown there. But he does not want to visualize his parents in this painful situation.

We have obtained a translation from the Polish of the passage that the mother read to us. Reading this makes it clear to us how threatening it must be to Joel. After recounting her initial experiences in the ghetto, the mother writes: "(P) *Later the Germans came to our house and got the small children. They broke down the wall, searched for gold, and left things in a terrible mess.*" Here she stops for 12 seconds and then continues reading: "(P) *We took in a child. My mother had accepted that child from a woman who had two children. My mother accepted that child and they got her, too. That was the worst thing you could possibly see- how they took that child away from her mother and then threw her out the window.*"

Probably it was that child whose cries: "(P) *Don't give me to the Germans*" Lena still hears today. Lena is unable to give us the name of this child or that of her friend. We may assume that Lena feared the day would come when her mother could no longer protect her, would have to give her away, or would have to watch as they murdered Lena.

It is likely that Joel had already heard at least fragments of this traumatic incident in the family history: his grandmother had to surrender a child that had been entrusted to her to her murderers. This grandmother had lived with Joel and his family, and had died when Joel was ten years old. But he cannot fully admit to himself that this family incident happened. Neither can he accept the emotional significance of the fact that mothers were unable to protect their children, or even today might be unable to do so. Nevertheless, the theme of "the murder of children in the Lodz ghetto" is always present, even though nobody ever talks about it openly. In the family interview, as well as in the individual interviews with Amos, his sister, and Lena, his wife, there are many hints which become meaningful to us only gradually, through pains-



taking analysis and historical research. This is most obvious in the case of Amos cannot talk about anything in the family history that relates to the Lodz ghetto. He feels responsible for the murder of his mother and, particularly, of his younger siblings because he left them behind. He must also avoid letting his wife bring up her memories, because her story reminds him of those who had been utterly powerless to resist their murderers. The murder of the children in the Lodz ghetto and the transport of children to Auschwitz form part of the family history. These themes present such a terrible psychological threat to all of them that they must not be addressed and must remain a family secret. In this way, Lena und Amos belong to that group of married couples who are connected by similar secrets (cf. Pincus/ Dare 1978).

In this family, the past weighs so heavily on the family members that they have to keep silent about it. However, the family interview gave us the impression of being the first step toward opening up a dialogue in the family. If this should come about, it may well provide some relief to all the family members.

### *The Seewald Family: The unsaid orders*

Bettina Voelker and the author conducted the family interview in the home of the daughter, with the grandparents, the daughter, and the granddaughter.

In contrast to the Goldstern family and other families of survivors of the Shoah, in the first half of the interview (ca. 45 min.), the Seewald family spoke, in response to our opening question, about events of the last few months and not directly about the National Socialist era. During this part of the interview, comparisons were made all the time between the present and the past with reference to the themes of "bringing up children" and "the role of women". The grandfather consistently expressed his admiration for the discipline and obedience that prevailed in the past. One of his sayings is: "*My parents used to say 'those who have not learned to take orders will not be able to give orders later on'.*" (He underscored every word by hitting the table with his fist.) The second part also lasted about 45 minutes. The Nazi crimes were the main topic and the discussion was very lively.

The grandmother directed the dialogue during the entire discussion. Who was allowed to speak and the themes to be discussed depended largely upon her; she held her husband back when he talked too much, and she decided when to end the conversation. Her first argument was to counter her husband's statement that orders must be obeyed unquestionably. Her counter-argument was that orders had been obeyed out of fear. In the second half of the conversation, she tried to keep her husband from talking, then suddenly put an end to the dialogue and practically fled the room. Let us consider the second part of the conversation. It is initiated by the interviewer with the

question: *"What question would individual members of the family wish to ask each other that they have not asked before?"* There was universal agreement: nobody has any questions. We are assured that everybody knows everything about everybody else. Addressing her daughter in particular, the grandmother states emphatically: *"We don't keep secrets from each other, right...? What more do you want to know, you know everything about our lives"*. The daughter confirms that there are no gaps for her in the family history. The granddaughter is the only one who does not fit completely in this remarkably harmonious dialogue, saying that she needs more time to think this over. Then she talks about her husband Frank who frequently quarrels with the grandfather. Is there perhaps a connection between this quarrel and the family secrets that allegedly do not exist? The grandfather hints at the possible background of this dissonance: *"Our experiences were quite different; we suffered so much."* Now Mechthild starts to talk about her son-in-law. She mentions that his family never talks about their family history before 1945, which points to a possible Nazi past there. She asserts that *"her family always had an undeniably strong aversion to all things military"* and thus explains the disagreement with the son-in-law who feels differently about the time before 1945. In answer to the interviewer's question *"What determines your feelings concerning the time before 1945"?*, she starts talking, after some hesitation, about a guided fantasy voyage which she had undertaken with the help of a therapist. Thus guided in her imagination, she first remembered an actual experience. At the age of five, she finds herself, accompanied by her father, in a swampy meadow where they have gone to cut some grass to feed their rabbits. In this way, Mechthild transfers herself back to that time in her life when her grandfather's body was found in a river and, thematically, moves in the direction of water and death. This swampy meadow is a terrain that concentration camp inmates had cleared in 1945; hundreds of them had died doing this work. The actual memories of herself as a five-year-old child in a swampy meadow gradually turn into imagining the inmates in that swampy terrain and:

*"(4) Concentration camp inmates were who probably had been there (1) fused with this dream fantasy, metamorphosed, well into World War II soldiers, well into the grief (3) and (7) then I have (1) I always found it very difficult to imagine (2) that my father could ever have stood ((Petra is coughing)) next to a cannon, that is (1) hm, an image that does not at all fit my father (1) for me (2) and in this (1) well, that is what came next in the day-dream (2) hm (3) I saw (1) that he, (1) pretty much crouching, he sat so with the (1) so as one actually sits when one (2) can no longer do anything (2) there at the cannon (11) ((Mechthild cries))."*

Let us compare this fantasy of Mechthild's, in which she visualizes her father as a victim, with the declarations of Joel, who refuses to think of his parents

as victims. This illustrates a fundamental difference between the fantasies of the descendants of Nazi perpetrators and those of Holocaust survivors. The son of survivors is afraid of confronting the gruesome reality of what his parents experienced, but does not deny what happened. The daughter of a soldier, who served in a war of annihilation, visualizes concentration camp survivors, so that she can see her father in the role of a victim - he does not stand next to a cannon, but crouches, powerless. For the sake of self-protection, Joel must avoid visualizing reality, while Mechthild, in an effort to protect herself, denies reality. It is true that some children of survivors deny or reinterpret parts of their parents' past in a manner not very different from Mechthild. Nevertheless, we may assume that the defence mechanisms we have described here are typical for the descendants of survivors, as distinguished from those of Nazi perpetrators. To put it simply: the children and grandchildren of survivors have no need to resort to a strategy of transforming perpetrators into victims, and the children and grandchildren of perpetrators need not fear a realization of the suffering but rather of the actions of their parents and grandparents.

Let us now look at the dynamics of the dialogue induced by the sequence just quoted. Mechthild is crying, there is a long pause and everybody in the room is very attentive. The grandfather speaks first and, unlike his previous long speeches, his only utterance is "Yes". His wife, too, was able to stand the long pause without intervening. We may assume that Mechthild has succeeded in presenting her parents as victims instead of perpetrators: she is fulfilling their delegation.

The grandmother becomes more and more nervous and fidgets until I finally ask her to speak. She recounts that she saw the concentration camp inmates every day marching through the forest when she rode to work on her bicycle:

*"And I saw this every day ((her hand hits the table)) every day again. That anybody should - you can not get rid of that, I have not gotten rid of that to this day (2) and nobody understands that. And when they had to march on foot from the camp to the brickyard some could not walk any further and two of them formed a seat between them by joining hands so that the third could sit upon it, he, too had to get to work and they already looked like (2) skulls."*

It is interesting that the sequence of the themes "victims - perpetrators - victims" established in the voyage that Mechthild undertook in her imagination, is also maintained here in the family dialogue: the sequence of the concentration camp inmates is closed by addressing the theme of the grandfather's role as victim. This time, it is the grandfather who closes the circle by seeing a parallel between his life history and that of the concentration camp inmates:

*"We had the same experience in '45 when we were prisoners of war ((Anna clears her throat)), and we were not political, we were prisoners, we had been soldiers ((Petra coughs)) who, (2) as we had sworn, fought for the fatherland, (1) as by contract, (Anna: "yes") not like volunteers, otherwise we would have been hung on a tree or shot."*

Mr. Seewald now speaks of the war crimes in which his brother in law had been forced to take part. He also drops hints that he, too, followed criminal orders: *"In those times, during the war, they gave orders, they were indescribable ((his fist hits the table)) what the soldiers had to do was (1) really not human."*

The interviewer now offers Mr. Seewald the opportunity to make a partial confession. She refers to the "Kommissarbefehl," a general order of the German high command that all "Kommissare" of the Red Army were to be killed when captured.<sup>201</sup> *"You mean, for instance, that Soviet "Kommissare" had to be shot or what other orders do you have in mind?"* But Mr. Seewald goes a step further: *"Well here, hm, the, hm, extermination of people, for instance."*

We may assume that more is hidden behind that stammered *"Well here, hm, the, hm,"* than we can guess, and that the formulation *"extermination of people"* represents the correction of a sentence already started that would have referred to a specific incident. It remains an open question what he means by *"here."*

The family now becomes extremely agitated. The mood of unrest sets in when the grandmother snarls at her husband that he should stop talking about all this. The granddaughter who has said nothing for a long time, starts talking about the former concentration camp, which is located near the grandparents' home, the concentration camp Sachsenhausen. She now says what nobody had expected her to reveal: her paternal great-uncle, an SS officer, was an SS guard in the concentration camp<sup>202</sup>. The grandmother is surprised and asks who that would be; the mother explains the relationship without further ado. Nobody appears threatened or shocked by this revelation; but there is a vivid interest in it. A family secret is being disclosed, and the sequence of contributions to the conversation seems to indicate that in this way, the revelation of another secret, related to the orders to commit murder mentioned above, is being avoided.

The threat now becomes too great for the grandmother. She pulls at her husband's pant-leg, signalling that she wants to go home. But the grandfather starts a longwinded argument that the little people had been innocent; the guilty ones had been the capitalists who had remained in the background. At

---

201 A "Kommissar" was attached to every Soviet regiment or military unit of similar size. This was a communist party functionary in charge of the political education and supervision of that unit.

202 In the individual interviews the fathers' family had been described as one consisting entirely of members of the anti-Nazi underground and other system opponents.

this point, my colleague intervenes by asking the grandfather once more about the orders he had received, if he remembers one of them in particular.

The grandfather replies: *"Well, you know, hm, I ((the granddaughter coughs)) do not want to go any further, go into the matter, like you. The time I spent there (I) I also do not want to des- and I also want that-"*

The grandmother interrupts him and insists that one could not describe this. The daughter is of the opinion this would be too burdensome, turns to me and says in a way meant to settle the argument: *"That's going too far."*

The granddaughter remains silent but at this very moment she coughs more. The grandmother reprimands Petra: *"You should not talk so much, Petra; talking a lot causes one to cough a lot."* After that, Anna states with great determination: *"I've got to go home now."*

In the final part of the interview, I ask the family to let us know what impression the interview has left on them. The grandfather immediately says "harmonious." The grandmother assures us that they always feel happy when they get together and at such occasions they would not talk about "anything so horrible." The granddaughter now intervenes to say that the picture of harmony were nothing but a distortion and a lie. She respects her grandparents' reluctance to talk, but *"underneath all that lay, unmentioned (I) hm, some kind of orders that had been given and some experiences with which I am not acquainted (I) ((coughs)) and which I don't know because you can not talk about them."*

This gives rise to a lively dialogue between granddaughter and grandmother. The grandmother evades a further quarrel, saying this would affect her nerves, would cause her blood sugar count to rise, and she should not get upset. The daughter now tries to protect the grandparents. She states that she thinks Petra misunderstands the grandparents; they would not want to *"play the harmony card"* but would always *"discuss everything that is in the air."* The grandfather once more argues in great length that the "big shots" are the ones guilty of the *"extermination of people."* Now the grandmother says: *"Stop it, Hans; I've got to go home now."* The grandfather continues his comments in the same manner. The grandmother then says: *"That's going too far for me; I can't hear this all the time; let's go, Hans."* As the grandmother practically flees the room, the grandfather takes his leave from us remarking that we can now *"pick the goodies out of the conversation and throw the rest into the waste basket."*

Notwithstanding this sudden ending, we have the impression that the family interview clearly reveals the following: all the participants feel burdened by the Nazi past but, nevertheless, somehow want to talk about it. The daughter started the dialogue on the Nazi period by talking about her son-in-law, introducing him by making a reference to his National Socialist family background. Against this she posited her guided fantasy and the image of her father as a victim of World War II. The grandmother, on one hand, obstructed

the dialogue more than anyone else; on the other hand, she was the one who revealed that she felt oppressed by her memories of the concentration camp inmates and thus revealed that she witnessed these crimes almost daily. The grandfather addressed the theme of "criminal orders", but he not only accepted the offer of the interviewer to limit the interview to the subject "Kommissarbefehl"(see above); his cooperation went far beyond that.

The grandfather's past, and possibly the grandmother's, too, make it difficult to get the dialogue going. This past is too much of a threat to all of them to be revealed. But it determines, however, the course of the entire conversation which is dominated by the theme of "obeying criminal orders" and by oblique references to the fact that the grandfather carried out these orders. Though the daughter is aware of this, she does not realize what she is avoiding, or, respectively, denying. Thus, she is able to conceive of her father as a victim and parallel his role with that of the concentration camp inmates. On the other hand, the granddaughter hardly suspects anything, not even subconsciously. She unconsciously acts out the past through her fears, for example through her phobia of drowning, and through her choice of spouse.

### *Concluding remarks*

When we compare the Seewald family dialogue with that of the Goldstern family, we notice certain similarities at first glance. In both families, the participants in the dialogue try to keep each other from making certain revelations and at the same time want to talk about them. The dynamic of both dialogues is determined by a central theme. In the case of the Goldsterns, this is the ghetto experience; in that of the Seewalds, the criminal orders which the grandfather probably carried out. In both instances, it is mainly one of the grandparents who keeps the spouse from addressing the theme of the burdensome past. In the case of the Goldstern family, we were able to figure out why the grandfather tries to prevent his wife from verbalizing her ghetto experiences, or, respectively, why he fears it being verbalized himself; but in the case of the Seewald family, all this remains a matter of conjecture. The determining theme for grandmother Seewald is her fear and one may ask oneself what is it that she fears till today.

She herself talks of the Russians who could come back. As an interpreter, this also makes me think of the 18,000 Russians who were shot in the nearby concentration camp, not to mention the Russian prisoners of war who were murdered on the Eastern front by German *Wehrmacht* units.

In the case of the grandparents, as well as in that of their descendants, hugely differing burdens, fears, and sentiments are evoked by the themes "obeying orders" and "ghetto experiences." Members of the Goldstern family suffer due to their erstwhile powerlessness, their inability to do anything

about the murder of infants and other atrocities, their own fear of death, the fear of their own extermination. The Seewald family members suffer because they feel guilty about their involvement in these events and they fear the revenge of their victims. The descendants suffer from a past that has been made known to them only through diffuse transmission.

While the Goldstern family tries to avoid visualizing and addressing the theme of a family history that they do not deny, the Seewald family has a need for family secrets and the myth of having been victims; without these, they would be forced to admit that the events which they deny eventually occurred. The Seewald family members greatly differ from those of the Goldstern family in yet another respect: they do not try to evade addressing the themes of those parts of the family history which are more or less known. Instead they tell some family secrets to prevent other parts of their past from being revealed.





## References

- Absolon, R. (1960): Wehrgesetz und Wehrdienst 1935-1945. Das Personalwesen der Wehrmacht. Boppard am Rhein: Harald Boldt
- Agde, G. (1994): Sachsenhausen bei Berlin. Speziallager Nr. 7 1945-1950. Berlin: Aufbau Taschenbuch Verlag
- Ahlheim, R. (1985): "Bis ins dritte und vierte Glied". Das Verfolgungstrauma in der Enkelgeneration. In: *Psyche*, 4, 330-354
- Almog, O. (1994): The "Sabras": A Sociological profile. Unpublished Ph. D. thesis; Haifa University
- Anzieu, D. (1984): *The group and the unconscious*. London: Routledge & Keagan Paul
- Arendt, H. (1977): *Eichmann in Jerusalem: A Report on the Banality of Evil*. New York: Penguin
- Auerhahn, N. / Laub, D. (1984): Annihilation and Restoration: Post-Traumatic Memory as Pathway and Obstacle to Recovery. In: *International Rev- Psycho-Anal.*, 11, 327-344
- Auerhahn, N.C., Prelinger, E. (1983): Repetition in the concentration camp survivor and her child. In: *International Review of Psychoanalysis*. 10, 31-45.
- Autorenkollektiv (1982): *Sachsenhausen / 4. Auflage*. Berlin: VEB Deutscher Verlag der Wissenschaften.
- Ball-Kaduri, K.J. (1964): Die Wehrmacht und die deutschen Juden im Zweiten Weltkrieg. In: *Zeitschrift für die Geschichte der Juden*. 1. Jg. (1-4), 141-147
- Bank, St. P. / Kahn, M. (1982): *The sibling Bond*. New York: Basic Books
- Bar-On, D. (1989a): *Legacy of Silence*. Cambridge: Harvard University Press.
- Bar-On, D. (1989b): The Rabbi from Jerusalem. In: *Ibid*: 1989a, 160-178
- Bar-On, D. (1990): Die Kinder der Holocaust-Täter und ihre Suche nach Integrität. In: *Integrative Therapie* 16 (3), 222-245
- Bar-On, D. (1992a): "Israeli and German students encounter the Holocaust through a group process: 'Partial relevance' and 'working through'". In: *International Journal of Group Tensions*, Vol 22 (2), 81-118
- Bar-On, D. (1992b): A Testimony on the Moment Before the (Possible) Occurrence of a Massacre. In: *Journal of Traumatic Stress*. 5 (2) 289-301.
- Bar-On, D. (1995a): *Fear and Hope. Three Generations of the Holocaust*. Cambridge: Harvard University Press
- Bar-On, D. (1995b): Begegnungen zwischen Nachkommen von Holocaust-Überlebenden und Nachkommen von Holocaust-Tätern: Ein Weg, um mit der Vergangenheit für die Zukunft zu kämpfen. In: Attia, I. et al. (Ed.): *Multikulturelle Gesellschaft und monokulturelle Psychologie?* Tübingen: Dgvt-Verlag, 52-77
- Barocas, H.A. / Barocas, C.B. (1979): Wounds of the fathers: The next generation of Holocaust victims. In: *International Review of Psycho-Analysis* , 6 (3) 331-340
- Beling, E. (1967): *Die gesellschaftliche Eingliederung der deutschen Einwanderer in Israel*. Frankfurt a. M.:Europäische Verlagsanstalt
- Benz, W. (Ed.) (1994): *Das Exil der kleinen Leute. Alltagserfahrung deutscher Juden in der Emigration*. Frankfurt a. M.: Fischer
- Bergmann, M.S. / Jucovy, M.E. (Ed.) (1982): *Generations of the Holocaust*. New York: Basic Books.

- Bergmann, W. (1990): Der Antisemitismus in der Bundesrepublik Deutschland. In: Strauss, H. / Bergmann, W. / Hoffmann, Ch. (Ed.): Der Antisemitismus der Gegenwart. Frankfurt a. M.: Campus, 151-166
- Bergmann, W. / Erb, R. (1991): "Mir ist das Thema Juden irgendwie unangenehm". In: Kölner Zeitschrift für Soziologie und Sozialpsychologie 43, 502-519
- Bloom, S. (1949): Dictator of the Lodz Ghetto. The strange history of Mordechai Chaim Rumkowski. In: Commentary ,7, 111-122
- Bodemann, Y. M. (1996): Gedächtnistheater. Die jüdische Gemeinschaft und ihre deutsche Erfindung. Hamburg: Rotbuch Verlag
- Boszormeny-Nagy, I. (1975): Dialektische Betrachtung der Intergenerationen-Familientherapie. In: Marriage - Ehe. Zentralblatt für Ehe- und Familienkunde. Tübingen: Katzmann, 12, 117-131
- Boszormeny-Nagy, I. /Spark, G. (1973): Invisible Loyalties. New York: Harper & Row
- Bowlby, J. (1960): Grief and Mourning in Infancy and Early Childhood. In: Psycho-Anal. Study Child, 15, 9-52
- Bowlby, J. (1961): Processes of Mourning. In: The International Journal of Psycho-Analysis, XLII, 22-341
- Bowlby, J. (1973): Separation, Anxiety and Anger. London: Hogarth
- Bowlby, J. (1980): Lost, Sadness and Depression. London: Hogarth
- Browning, C. R. (1992): Ordinary Men: Reserve Police Battalion 101 and the Final Solution in Poland". New York: Harper Collins Publishers, Inc./Aaron Asher Books.
- Burgauer, E. (1993): Zwischen Erinnerung und Verdrängung. Juden in Deutschland nach 1945. Reinbek bei Hamburg: Rowohlt
- Byng-Hall, J. (1973): Family myths used as defence in conjoint family therapy. In: Br. J. med. Psychol., 46, 239
- Carlebach, E. et al. (1988): Buchenwald. Ein Konzentrationslager. Berlin: Dietz-Verlag
- Carter, B. / McGoldrick, M. (1988): The changing family life cycle. Boston: Allyn and Bacon
- Dabrowska, D. / Dobroszycki, L. (1986): The Chronicle of the Lodz Ghetto 1941-1944. New Haven and London: Yale University Press
- Dahmer, H. (1990): Derealisierung und Wiederholung. In: Psyche 44, (2), 133-142
- Danieli, Y. (1980): Countertransference in the treatment and study of Nazi Holocaust survivors and their children. In: Victimology, 5, (2-4), 355-367
- Danieli, Y. (1982): Families of Survivors of the Nazi Holocaust: Some short- and long-term effects. In: Spiegelberger, Ch. / Srasaso, I. (Ed.) (1982): Stress & Anxiety, Series in Clinical & Community Psychology, 8, 405-421
- Danieli, Y. (1993): Diagnostic and therapeutic use of the multigenerational family tree in working with survivors and children of survivors of the Nazi-Holocaust. In: Wilson, J.P. / Raphael, B. (Ed.): International Handbook of Traumatic Stress Syndrome. New York: Plenum Press.
- Dasberg, M. (1993): The Third and Three Generations Relations in Families of Holocaust survivors. Unpublished B.a. Thesis, Tel-Aviv University (in Hebrew)
- Davidson, Sh. (1980): The clinical effects of massive psychic trauma in families of Holocaust survivors. In: Journal of Marital & Family Therapy, 6, (1), 11-21
- Deutsch, H. (1937): Absence of Grief. Psychoanalytical Quarterly, 6, 12-22.

- Deutscher Bundestag (Ed.) (1995): Materialien der Enquete-Kommission. "Aufarbeitung von Geschichte und Folgen der SED-Diktatur in Deutschland"- Bd VII (1)
- Deutschland im Zweiten Weltkrieg (1986), Berlin: Akademie-Verlag, Vol. 5
- Diehl, M. (1993): Auf Positionssuche: Zionismus, Palästina-Problem und Israel aus der Sicht der Freien Deutschen Jugend von 1946 bis 1953. In: Jahresbericht des Instituts für zeitgeschichtliche Jugendforschung, Berlin: 81-115
- Dokumente der Sozialistischen Einheitspartei Deutschlands, Vol. 4, Berlin 1954, 199-219
- Drobisch, K. (1977): Widerstand in Buchenwald. Berlin: Dietz-Verlag
- Ebbinghaus, A. (1987): Opfer und Täterinnen. Frauenbiographien des Nationalsozialismus. Nördlingen: Greno
- Ehmann, A. (1988): 1933-1945. Verfolgung - Selbstbehauptung - Untergang. In: Juden in Berlin 1671-1945. Ein Lesebuch. Berlin: Nicolai, 245-249
- Eisen, G. (1988): Children and Play in the Holocaust. Amherst: The University of Massachusetts Press.
- Eissler, K. R. (1963/1984): Die Ermordung von wievielen seinen Kinder muß ein Mensch symptomfrei ertragen können, um eine normale Konstitution zu haben? In: Lohmann, H. M. (Hg.): Psychoanalyse und Nationalsozialismus. Frankfurt a.M.: Fischer, 159-209.
- Eissler, K. R. (1968): Weitere Bemerkungen zum Problem der KZ-Psychologie. In: Psyche 22, 452-463.
- Elon, A. (1981): The Israelis. Jerusalem: Adam (in Hebrew)
- Encyclopedia of Holocaust (1990). Jäckel, E. / Longerich, P. / Schoeps, J. H. (Eds.). Tel Aviv: Sifriat Poalim Publishing House. German version (1995): Enzyklopädie des Holocaust. München: Piper
- Eschwege, H. (1988): Die jüdische Bevölkerung der Jahre nach der Kapitulation Hitlerdeutschlands auf dem Gebiet der DDR bis zum Jahre 1953. In: Arndt, Th. et al. (Ed.): Juden in der DDR. Geschichte - Probleme - Perspektiven. Duisburg:
- Feilchenfeld, W. (1972): Die Durchführung des Haavara-Transfers. In: Feilchenfeld, W. / Michaelis, D. / Pinner, L.: Haavara-Transfer nach Palästina und Einwanderung Deutscher Juden 1933-1939. Tübingen: Mohr, 37-64
- Feldman, J. (1995a): "It is my brothers I am seeking". Israeli youth pilgrimage to Holocaust Poland. In: Jewish Ethnology & Folklore Review. Win., 251-275
- Feldman, J. (1995b): "Über den Gräbern mit gehißter Fahne Israels" - Die Struktur und Bedeutung israelischer Jugendreisen nach dem Polen der Schoah. In: Schreier, H. / Heyl, M. (Ed.): "Daß Auschwitz nicht noch einmal sei...". Zur Erziehung nach Auschwitz. Hamburg: Krämer, 335-365
- Ferreira, A. J. (1963): Family Myth and Homeostasis. In: Arch. Gen. Psychiat. 9, 457-462
- Fischer, W. (1978): Struktur und Funktion erzählter Lebensgeschichten. In: Kohli, M. (Ed.): Soziologie des Lebenslauf. Darmstadt/Neuwied: Luchterhand, 311-336
- Fischer, W. (1982): Time and Chronic Illness. A Study on Social Constitution of Temporality. Berkeley (Habilitationsschrift)
- Fischer-Rosenthal, W. (1991): Biographische Methoden in der Soziologie. In: Flick, U. / Kardorff, E. v. / Keupp, H. / Rosenstiel, L.v. / Wolff, St. (Hg.) (1991): Handbuch für Qualitative Sozialforschung. München: Psychologie Verlags Union, 253-256

- Fischer-Rosenthal, W. (1992): Über-Lebensgeschichte. Von Daniel, der doch kein Priester wurde, und von Micki, der kein Jude war, und von der Qual des Lebens. In: *Psychosozial*, 15 (I/II), 17-26
- Fischer-Rosenthal, W. (1995): Schweigen - Rechtfertigen - Umschreiben. Biographische Arbeit im Umgang mit deutschen Vergangenheiten. In: Fischer-Rosenthal, W./Alheit, P. (Ed.): *Biographien in Deutschland. Soziologische Rekonstruktionen gelebter Gesellschaftsgeschichte*. Opladen: Westdeutscher Verlag.
- Fischer-Rosenthal, W. (1996): Strukturelle Analyse biographischer Texte. In: Brähler, E. / Adler, C. (Ed.): *Quantitative Einzelfallanalysen und qualitative Verfahren in der Public Health*. Gießen: Psychosozial-Verlag, 99-161
- Framo, J. L. (1972): Das Wesen der Symptome aus familientransaktioneller Perspektive. In: Sager, C. J. / Singer Kaplan, H.: *Handbuch der Ehe- Familien und Gruppentherapie*, Vol. II, München: Kindler, 329-374.
- Frank, N. (1987): *Der Vater. Eine Abrechnung*. München:
- Freud, S. (1899): *On Screen Memory*. Standard Edition, Vol.1
- Freud, S. (1912-13): *Totem and Taboo*. Standard Edition, Vol.13
- Freyberg, J. T. (1980): Difficulties in Separation-Individuation as Experienced by Offspring of Nazi Holocaust Survivors. In: *American Journal of Orthopsychiatry*, 50, (1), 87-95
- Gampel, Y. (1988): Facing war, murder, torture, and death in latency. In: *Psychoanalytic Review* 1988 Win Vol. 75, (4), 499-509
- Gampel, Y. (1992): I was a Shoah child. In: *British Journal of Psychotherapy*, Sum Vol. 8, (4), 390-400
- Genin, S. (1991): "Wie ich in der DDR aus einer Kommunistin zu einer Jüdin wurde". In: Benz, W. (Ed.), 309-326.
- Gershon, K. (1966): *We came as Children*. London: V. Gollancz
- Gilad, N. (1995): *Memory of the Holocaust in the Family: Biographic and narrative Studies of Three Generations*. unpublished M.A. thesis, Tel Aviv University (in Hebrew)
- Gilbert, M. (1985): *The Holocaust*. New York: Henry Holt and Company
- Gilbert, M. (1988) *The Atlas of the Holocaust*. Israel: Pergamon Press Steimatsky
- Gilbert, M. (1995): *Endlösung. Die Vertreibung und Vernichtung der Juden*. Reinbeck bei Hamburg: Rowohlt
- Giordano, R. (1990): *Die zweite Schuld oder Von der Last Deutscher zu sein*. Taschenbuch-Ausgabe, München: Droemersche Verlagsanstalt
- Glaser, B.G. / Strauss, A.L. (1967): *The discovery of grounded theory. Strategies for qualitative research*. Chicago: Aldine
- Goldhagen, D. J. (1996): *Hitler's Willing Executioners*. New York: Alfred Knopf Inc.
- Goschler, C. (1993): *Paternalismus und Verweigerung. Die DDR und die Wiedergutmachung für jüdische Verfolgte des Nationalsozialismus*. In: Benz, W. (Ed.): *Jahrbuch für Antisemitismusforschung* 2. Frankfurt a. M.: Campus, 93-117.
- Gossweiler, K. (1986): *Aufsätze zum Faschismus*. Berlin: Akademie-Verlag
- Groehler, O. (1992): *Erblasten: Der Umgang mit dem Holocaust in der DDR*. In: Loewy, H. (Ed.): *Holocaust: Die Grenzen des Verstehens. Eine Debatte über die Besetzung der Geschichte*. Reinbek: Rowohlt, 110-127.

- Groehler, O. (1994): SED, VVN und Juden in der sowjetischen Besatzungszone Deutschlands (1945-1949). In: Benz, W. (Ed.): Jahrbuch für Antisemitismusforschung 3. Frankfurt a. M.: Campus, 282-302.
- Groehler, O. (1995): Antifaschismus und jüdische Problematik in der SBZ und der frühen DDR. In: Groehler, O. / Keßler, M.: Die SED-Politik, der Antifaschismus und die Juden in der SBZ und der frühen DDR. hefte zur ddr-geschichte 26. Berlin, 5-31.
- Gronemann, S. (1979): Erinnerungen. In: Richarz, M. (Ed.): Jüdisches Leben in Deutschland. Selbstzeugnisse zur Sozialgeschichte im Kaiserreich. Stuttgart, 406f
- Grossmann, K. R. (1969): Emigration. Geschichte der Hitler-Flüchtlinge 1933-1945. Frankfurt a. M.: Europäische Verlagsanstalt
- Grote, Ch. / Rosenthal, G. (1992): Frausein als Entlastungsargument für die biographische Verstrickung in den Nationalsozialismus? In: Tel Aviver Jahrbuch für Deutsche Geschichte. Gerlingen: Bleicher, 289-318
- Grubrich-Simitis, I. (1979): Extremtraumatisierung als kumulatives Trauma. In: Psyche, 33, 991-1023.
- Grünberg, K. (1991): Die Generation nach der Shoah: Eine psychologische Untersuchung über Nachkommen von Überlebenden der nationalsozialistischen Judenverfolgung. In: Stoffels, H. (Ed.): Schicksal der Verfolgten. Berlin / Heidelberg: Springer, 173-189
- Grunenberg, A. (1991): Antifaschismus - ein deutscher Mythos. Anmerkungen zu einem verdrängten Kapitel der Linken. In: Die Zeit, No. 18, 26th of April, 64
- Guggenheim, W. (1987): 30mal Israel. München / Zürich: Piper
- Gurwitsch, A. (1964): The Field of Consciousness. Pittsburgh.
- Harshalom, A. (1994): Life from Ashes. Tel-Aviv: Milo Ltd (in Hebrew)
- Heer, H. / Naumann, K. (Ed.) (1995): Vernichtungskrieg. Verbrechen der Wehrmacht 1941-1944. Hamburg: Hamburger Edition
- Hilberg, R. (1961/1990): The Destruction of the European Jews. Chicago. German Edition in 1990: Die Vernichtung der europäischen Juden. Frankfurt a. M.: Fischer.
- Hofer, W. (1985): Studien der Judenverfolgung im Dritten Reich 1933-1939. In: Strauss, H. A. / Kampe, N. (Ed.): Antisemitismus. Von der Judenfeindschaft zum Holocaust. : Frankfurt a. M. / New York, 172-185
- Hrdlicka, M. R. (1992): Alltag im KZ. Das Lager Sachsenhausen bei Berlin. Opladen: Leske und Budrich
- Imber-Black, E. (Ed.) (1993): Secrets in Families and Family Therapy. New York/London: W.W. Norton & Company
- Jäger, H. (1982): Verbrechen unter totalitärer Herrschaft. Frankfurt a. M.: Walter-Verlag
- Jefferson, C. (1978): Some Notes on the Use of Family Sculpture in Therapy. In: Family Process, 17, 68-76
- Jokl, A. M. (1961): Vergebung und Heilung. Eine Falldarstellung. In: Wege zum Menschen. Göttingen, 229-238
- Jordans, P. (1996): Zur familien- und lebensgeschichtlichen Bedeutung des Nationalsozialismus. unpublished M.A.-thesis. University of Kassel, Department of Social Work
- Karpel, M. A. (1980): Family secrets. In: Family Process, 19, 295-306

- Keilson, H. (1979): Sequentielle Traumatisierung bei Kindern. Stuttgart: Enke
- Kestenberg, J. (1989): Transposition revisited: Clinical, therapeutic, and developmental considerations. In: Marcus, P. / Rosenberg, A. (Eds.): *Healing their wounds: Psychotherapy with Holocaust survivors and their families*. New York: Praeger, 67-82
- Kestenberg, J. (1991): Kinder von Überlebenden und überlebende Kinder. In: Stoffels, H. (Ed.): *Schicksale der Verfolgten. Psychische und somatische Auswirkungen von Terrorherrschaft*. Berlin Heidelberg: Springer, 110 - 126
- Kestenberg, J. / Kestenberg, M. (1987): Child killing and child rescuing. In: Neuman, G.: *Origins of Human Aggression*. New York: Human Sciences Press, 139-154
- Kestenberg, J.S. (1982): Survivor Parents and their Children. In: Bergmann, M.S. et. al., 83-102
- Kießling, W. (1993): Als "West-Emigrant" unter Verdacht. Der ominöse Tod Rudolf Feistmanns, Noel H. Field und die SED. In: *Tribüne*, 126, 118-128
- Klarsfeld, S. (1989): Vichy - Auschwitz. Die Zusammenarbeit der deutschen und französischen Behörden bei der "Endlösung der Judenfrage" in Frankreich. Nördlingen: Greno
- Klarsfeld, S. (1994): *Le mémorial des enfants juifs déportés de France*. Paris: "Les Fils et Filles des Déportés Juifs de France" (FFDJF) et "The Beate Klarsfeld Foundation"
- Klarsfeld, S. / Klarsfeld, B. (1991): *Die Kinder von Izieu. Eine jüdische Tragödie*. Berlin: Edition Hentrich
- Klee, E. / Dreßen, W. / Rieß, V. (1988): "Schöne Zeiten". *Judenmord aus der Sicht der Täter und Gaffer*. Frankfurt: Fischer
- Klein, H. (1986): Der Holocaust, seine Folgen und Bewältigungsmechanismen. In: Faust, V. (Hg.): *Angst, Furcht - Panik*. Stuttgart: Hippokrates, 157-162.
- Klein-Parker, F. (1988): Dominant Attitudes of Adult Children of Holocaust Survivors toward Their Parents. In: Wilson, J. / Harel, Z. / Kahana, B. (Ed.) *Human Adaption to Extreme Stress*. New York: Plenum. 193-218
- Kogon, E. (1950): *The Organization of the Camps*, In: *The theory and practice of Hell*. New York: Farrar Straus
- Kohli, M. (1986): Biographical Research in the German Language Area. In: Dulczewski, Z. (Ed.): *A commemorative book in Honor of Florian Znaniecki on the Centenary of his Birth*. Poznan, 91-110
- Konieczny, A. (1983): Die Zwangsarbeit der Juden in Schlesien im Rahmen der "Organisation Schmelt" In: Aly, G. et al.: *Sozialpolitik und Judenvernichtung. Gibt es eine Ökonomie der Endlösung?* Berlin: Rotbuch Verlag
- Konieczny, A. (1994): *Frauen im Konzentrationslager Groß-Rosen in den Jahren 1944-1945*. Panstwowe Muzeum Gross-Rosen. Walbrzych:
- Kovacs, E. / Vajda, J. (1994): "I have a certificate of not being an anti-Semite". *Identity of a "Social Jew": Its Roots in Life History*. In *Thalassa*, 2
- Krausnick, H. (1985): *Hitlers Einsatzgruppen*. Frankfurt a. M.: Fischer
- Kulturamt Prenzlauer Berg und Aktives Museum Faschismus und Widerstand e.V. (Ed.) (1992): *Mythos Antifaschismus. Ein Traditionskabinett wird kommentiert*. Berlin: H. Links
- Lagnado, L. M / Dekel S. C. (1992): *Children of the Flames. Dr. Josef Mengele and the Untold Story of the Twins of Auschwitz*. London: Pan

- Laub, D. / Auerhahn, N. C. (1991): Zentrale Erfahrung des Überlebenden: Die Versagung von Mitmenschlichkeit. In: Stoffels, H. (Ed.): Schicksale der Verfolgten. Psychische und somatische Auswirkungen von Terrorherrschaft. Berlin / Heidelberg: Springer, 254-276
- Le Chêne, E. (1971): Mauthausen. The History of a Death-Camp. London: Methuen & Co LTD
- Lentin, R. (publication in preparation): "Stories within stories": auto/biographical experiences of working with personal narratives of Israeli daughters of Shoah survivors. Forthcoming in: Auto/Biography Journal of the BSA Auto/Biography Study Group. Dublin, Ireland.
- Lieblich, A. (1987): Aviv Shnot. Tel-Aviv: Schocken Publishing House (in Hebrew)
- Lifton, R. J. (1968): The Survivors of the Hiroshima Disaster and the Survivor of Nazi Persecution. In: Krystal, H. Massive Trauma. New York: International University Press
- Lifton, R.J. (1967): History and Human Survival. New York: Vantage Books.
- Lomranz, J. (1990): Long-term adaptation to traumatic stress in light of adult development and aging perspective. In: Parris, M.A. et al. (Eds.): Stress and coping in later life family. Washington, DC: Hemisphere Publishers, 99-121
- Lomranz, J. / Shmotkin, A. Z. / Rosenberg, E. (1985): Time orientation in Nazi camp survivors. Forty Years After. In: American J. Orthopsychiat, 55, (2), 230-236
- Mahler, M. (1965): On the significance of the normal separation-individuation phase: with reference to research in symbiotic child psychosis. In: Schur, M. (Ed.) Drives, Affects, Behavior. New York: International Universities Press
- Mahler, M. / Pine, F. / Bergman, A. (1975): The Psychological Birth of the Human Infant. New York: Basic Books
- Malkinson, R. / Witztum, A. (1993): Sh'chol Ve-Hanzacha. (Bereavement and Commemoration in Israel). In: Malkinson, et al. (Ed.): "Ovdan Ve-Sh'chol Ba-Hevara Ha-Israelit" (Losses and Bereavement in Jewish Society in Israel). Jerusalem: 231-255
- Marcuse, H. (1990): Das ehemalige Konzentrationslager Dachau. In: Dachauer Heft, 6. Jg. (6), 182-206
- Märthesheimer, P./Frenzel, I. (Hg.) (1979): Im Kreuzfeuer: Der Fernsehfilm 'Holocaust'. Eine Nation ist betroffen. Frankfurt am Main: Fischer TB Verlag.
- Matussek, P. (1971): Die Konzentrationslagerhaft und ihre Folgen. Heidelberg: Springer.
- Mendelson, E. (1983): The Jews Of East Central Europe Between The World Wars. Bloomington: Indiana UP
- Mentzos, S. (1994): Interpersonale und institutionalisierte Abwehr. Frankfurt a. M.: Suhrkamp
- Meuschel, S. (1992): Legitimation und Parteiherrschaft in der DDR. Frankfurt a. M.: Suhrkamp
- Minushin, S. (1982): Families and family therapy. Tel-Aviv: Reshafim
- Mitscherlich, M. / Runge, I. (1993): Kulturschock: Umgang mit Deutschen. Hamburg: Klein Verlag
- Mittag, G. (1996): "Es gibt Verdammte nur in Gurs." Literatur, Kultur und Alltag in einem französischen Internierungslager. 1940-1942. Tübingen: Attempto-Verlag

- Moore, Y. (1994): Narrative Biographical Analysis. Life stories of second generation to Holocaust Survivors' Past and Present. unpublished M.A.-thesis. Beer Sheva, Israel: Ben Gurion University of the Negev.
- Moser, T. (1992): Die Unfähigkeit zu trauern: Hält die Diagnose einer Überprüfung stand? In: *Psyche*, 46, 5, 389-405
- Naor, M. (1996): *The Twentieth Century in Eretz-Israel*. Tel-Aviv: Am Oved Publishing house
- Niederland, W. G. (1968a): Clinical observation on the survivor syndrome, *International Journal of psychoanalysis*, 49
- Niederland, W. G. (1968b): The Problem of the Survivor. The psychiatric evaluation of emotional disorders in survivors of Nazi persecution. In: Krystal, H.: *Massive Psychic Trauma*. New York: International Univ. Press, 8-22
- Niederland, W. G. (1980): Folgen der Verfolgung: Das Überleben-Syndrom Seelenmord. Frankfurt a. M.: Suhrkamp
- Niederland, W. G. (1991): The Survivor Syndrome: Further Observations and Dimensions. In: *Journal of the American Psychoanalytic Association*, 29, No.2, 413-423.
- Niethammer, L./ Plato, A. von / Wierling, D. (1991): *Die volkseigene Erfahrung. Eine Archäologie des Lebens in der Industrieprovinz der DDR*. Berlin: Rowohlt
- Oberlaender, F. A. (1994): Die zerrissene Familie Herzberg: Ein mißlungener Assimilationsversuch und seine Folgen über drei Generationen. In: *System Familie*, 7, 2-18
- Oberlaender, F. A. (1996): "Wir aber sind nicht Fisch und nicht Fleisch." Christliche "Nichtarier" und ihre Kinder in Deutschland. Opladen: Leske und Budrich
- Ostow, R. (1989): *Jews in Contemporary East Germany: The Children of Moses in the Land of Marx*. London: MacMillan
- Papp, P. / Imber-Black, E. (1996): Family Themes: Transmission and Transformation, *Family Process*, 35, 5-20
- Papp, P. / Silverstein, O. / Carter, E. (1973): Family sculpting in preventive work with "well families". In: *Family Process* 12, 197-212
- Pawelczynska, A. (1979): *Values and Violence in Auschwitz*. Berkeley: University of California Press
- Pfetsch, F. R. (Ed.) (1991): *Konflikte seit 1945. Daten - Fakten - Hintergründe. Die arabisch-islamische Welt*. Freiburg i. Br. / Würzburg: Verlag Ploetz
- Pincus, L. (1978): Verdrängte Trauer. In: *Familiendynamik* 4, 269 -276.
- Pincus, L. / Dare, Ch. (1978): *Geheimnisse in der Familie*. Stuttgart: Deutsche Verlagsanstalt
- Pinner, L. (1972): Die Bedeutung der Einwanderung aus Deutschland für das jüdische Palästina. In: Feilchenfeld, W. / Michaelis, D. / Pinner, L.: *Haavara-Transfer nach Palästina und Einwanderung Deutscher Juden 1933-1939*. Tübingen: Mohr, 89-112
- Reinharz, J. (1986): Haschomer Hazair in Nazideutschland, 1933-1938. In: Paucker, A. (Ed.): *Die Juden im Nationalsozialistischen Deutschland*. Tübingen: Mohr, 317-351
- Richarz, M. (1986): Juden in der Bundesrepublik Deutschland und in der Deutschen Demokratischen Republik seit 1945. In: Brumlik, M. et al. (Ed.): *Jüdisches Leben in Deutschland seit 1945*. Frankfurt a. M.: Athenäum, 13-30



- Richarz, M. (1988): 1918-1933. Zwischen formaler Gleichberechtigung, Zionismus und Antisemitismus. In: *Juden in Berlin 1671-1945. Ein Lesebuch*. Berlin: Nicolai, 126-130
- Ringelheim, J. (1944): *Women and the Holocaust*. In: Rittner, C. / Roth, J.K. (Ed): *Different Voices: Women and the Holocaust*. New York: Paragon House, 371-418
- Ronge, V. (1992): *Übersiedler*. In: *Handwörterbuch zur Deutschen Einheit*. Frankfurt a. M.: Campus
- Rosenthal, G. (1987): „Wenn alles in Scherben fällt...“ Von Leben und Sinnwelt der Kriegsgeneration. Opladen: Leske & Budrich.
- Rosenthal, G. (1988): *Leben mit der soldatischen Vergangenheit in zwei Weltkriegen. Ein Mann blendet seine Kriegserlebnisse aus*. In: *Bios*, 1 (2), 27-38.
- Rosenthal, G. (1991). *German War Memories: Narrability and the Biographical and Social Functions of Remembering*. *Oral History*, 19 (2), 34-41.
- Rosenthal, G. (1992a): *Das kollektive Schweigen zu den Nazi-Verbrechen. Bedingungen der Institutionalisierung einer Abwehrhaltung*. In: *Psychozial*, 15, (3), 22-33
- Rosenthal, G. (1992b): *Antisemitismus im lebensgeschichtlichen Kontext. Soziale Prozesse der Dehumanisierung und Schuldzuweisung*. In: *ÖZG, Österreichische Zeitung für Geschichtswissenschaften*, 3, (4), 449-479
- Rosenthal, G. (1993a): *Erzählbarkeit, biographische Notwendigkeit und soziale Funktion von Kriegserzählungen. Zur Frage: Was wird gerne und leicht erzählt*. In: Hartewig, K. (Ed.): *Der lange Schatten. Widersprüchvolle Erinnerungen an den Zweiten Weltkrieg und die Nachkriegszeit aus der Mitte Europas*. *Bios, Sonderheft*, 5-24
- Rosenthal, G. (1993b): *Reconstruction of life stories. Principles of selection in generating stories for narrative biographical interviews*. In: *The Narrative Study of Lives*. 1, (1), 59-91
- Rosenthal, G. (1994): *Zur Konstitution von Generationen in familienbiographischen Prozessen. Krieg, Nationalsozialismus und Genozid in Familiengeschichte und Biographie*. In: *ÖZG, Österreichische Zeitschrift für Geschichtswissenschaften*, 5, (4), 489-516
- Rosenthal, G. (1995a): *Erlebte und erzählte Lebensgeschichte*. Frankfurt a. M.: Campus
- Rosenthal, G. (1995b) *Familienbiographien: Nationalsozialismus und Antisemitismus im intergenerationellen Dialog*. In: Attia, I. et al. (Ed.): *Multikulturelle Gesellschaft und monokulturelle Psychologie? Antisemitismus und Rassismus in der psychosozialen Arbeit*. Tübingen: Dgvt-Verlag, 30-51
- Rosenthal, G. (1995c): *Zerstörtes Leben - Fragmentierte Lebensgeschichten von Überlebenden der Shoah*. In: Fischer-Rosenthal, W. / Alheit, P. (Ed): *Biographien in Deutschland*. Opladen: Westdeutscher Verlag, 452-476
- Rosenthal, G. (Ed.) (1990): *"Als der Krieg kam, hatte ich mit Hitler nichts mehr zu tun". Zur Gegenwärtigkeit des "Dritten Reiches" in erzählten Lebensgeschichten*. Opladen: Leske & Budrich
- Rosenthal, G. (Ed.) (1986): *Die Hitlerjugend-Generation*. Essen: Blaue Eule.
- Rosenthal, G. / Bar-On, D. (1992): *A biographical case study of a victimizer's daughter*. In: *Journal of Narrative and Life History*, 2, (2), 105-127

- Rosenthal, P. A. / Rosenthal, St. (1980): Holocaust effect in the third generation: Child of another time. In: *American Journal of Psychotherapy*, 34, (4), 572-580
- Rosh, L. /Jäckel, E. (1990): Der Tod ist ein Meister aus Deutschland. Deportation und Ermordung der Juden. Kollaboration und Verweigerung in Europa. Hamburg: Hoffmann und Campe
- Rubin, S. (1993): Loss and bereavement. In: Malkinson, R. / Weitzum, A. (Eds.): *Loss and bereavement in Israeli Society*. Jerusalem: Misrad Habitahon, 21-38. (in Hebrew)
- Rubinstein, A. (1977): The birth and fall down of the mythodological Sabra. In: "Lihiot Am Hofshi". Jerusalem: Shoken
- Runge, I. (1990): Grauzone des Wartens. Zur jüdischen Selbstfindung auf deutschem Boden. In: *Blätter für dt. und int. Politik*, 8, 942-951
- Schade, W. (1995): Verfolgungserlebnisse in der Familien- und Lebensgeschichte. Die Bedeutung des Holocaust für die nachfolgenden Generationen - eine Biographieanalyse. Unpublish M.A.- thesis, University of Kassel. Department of Social Work.
- Schlegelmilch, C. (1994): Generationen im Gespräch. In: *Szenenwechsel im Alltag. Handreichungen für die neuen Bundesländer*. Frankfurt a. M.: Deutsches Institut für Erwachsenenbildung (DIE)
- Schlieben-Troschke, K. von (1981): *Psychologie der Zwillingspersönlichkeit*. Köln: Pahl Rugenstein
- Schreiber, F. / Wolffsohn, M. (1989): *Nahost. Geschichte und Struktur des Konflikts*. Opladen: Leske und Budrich
- Schüler, Th. (1993): Das Wiedergutmachungsgesetz vom 14. September 1945 in Thüringen. In: Benz, W. (Ed.): *Jahrbuch für Antisemitismusforschung* 2. Frankfurt a. M.: Campus, 118-138
- Schumann, W. et al. (Ed.) (1988): *Deutschland im Zweiten Weltkrieg, Vol. 6: Die Zerschlagung des Hitlerfaschismus und die Befreiung des deutschen Volkes (Juni 1944 bis zum 8. Mai 1945)*. Berlin: Akademie-Verlag
- Schütze, F. (1976): Zur Hervorlockung und Analyse von Erzählungen thematisch relevanter Geschichten im Rahmen soziologischer Feldforschung. In: *Arbeitsgruppe Bielefelder Soziologen (Hg.): Kommunikative Sozialforschung*. München: Fink, 159-260.
- Schütze, F. (1977): Die Technik des narrativen Interviews in Interaktionsfeldstudien. In: *Arbeitsberichte und Forschungsmaterialien Nr. 1 der Universität Bielefeld*. Fakultät für Soziologie
- Schütze, F. (1983): Biographieforschung und narratives Interview. In: *Neue Praxis*, 3, 283-294
- Schütze, F. (1984): Kognitive Figuren des autobiographischen Stegreiferzählens. In: Kohli, M. / Robert, G. (Hg.): *Biographie und soziale Wirklichkeit*. Stuttgart: Metzler, 78-117
- Schütze, F. (1992): Pressure and Guilt. The Experience of a Young German Soldier in World wWar II and its Biographical Implications. In: *International Sociology*, 7, (2 u. 3), 187-208; 347-367
- Schwarz, G. (1990): *Die nationalsozialistischen Lager*. Frankfurt a. M.: Campus
- Sdei-Ur, A. (1994): "The history of A-11667", Jerusalem: Carmel (in Hebrew)
- Segev, T. (1993): *The Seventh Million. The Israelis and the Holocaust*. New York: Hill and Wang

- Shiryon, S. (1988): The second generation leaves home: The function of the sibling subgroup in the separation-individuation process of the survivor family. *Family Therapy*, 15, (3), 239-284
- Sichrovsky, P. (1987): Schuldig geboren. Kinder aus Nazifamilien. Köln: Kiepenheuer und Witsch
- Sieder, R. (1995): Ein Hitlerjunge aus gutem Haus. Narrativer Aufbau und Dekonstruktion einer Lebensgeschichte. In: Fischer-Rosenthal, W. / Alheit, P. (Ed.): *Biographien in Deutschland*. Opladen: Westdeutscher Verlag, 330-359
- Sigal, J. et al. (1973): Some second generation effects of survival of the Nazi persecution. In: *American Journal of Orthopsychiatry*, 43, (3), 320-327
- Sigel, R. (1992): Im Interesse der Gerechtigkeit. Die Dachauer Kriegsverbrecherprozesse 1945-48. Frankfurt a. M.: Campus
- Simon, F. (1972): Sculpting the Family. In: *Fam. Proc.* 11
- Skutnik, T. (1979): Stutthof. Historischer Informator. Danzig: Krajowa Agencja Wydawnicza
- Solomon, Z. / Kotler, M. / Mikulincer, M. (1988): Combat-Related Posttraumatic Stress Disorder Among Second-Generation Holocaust Survivors: Preliminary Findings. In: *Am J. Psychiatry* 145, 7, 865-868
- Sperling, E. (1979): Familientherapie unter Berücksichtigung des Dreigenerationenproblems. In: *Psychother. med. Psychol.* 29, 207-213
- Sperling, E. / Massing, A. / Georgi, H. / Wöbbe-Möks, E. (1982): *Die Mehrgenerationen-Familientherapie*. Göttingen: Vandenhoeck & Ruprecht
- Stern, F. (1991): Im Anfang war Auschwitz. Antisemitismus und Philosemitismus im deutschen Nachkrieg. Gerlingen: Bleicher
- Stierlin, H. (1981): The Parent's Nazi Past and the Dialogue Between the Generations. In: *Family Process*, Vol. 20, 4, 379-390
- Stierlin, H. / Rücker-Embden, I. / Wetzel, N./ Wirsching, M. (1987): Das erste Familiengespräch. Stuttgart: Klett-Cotta
- Thürmer-Rohr, C. (1983): Aus der Täuschung in die Ent-Täuschung - Zur Mittäterschaft von Frauen. In: *beiträge zur feministischen theorie und praxis* 8, 11-26
- Titchener, J. L. (1967): Family System As A Model For Ego System. In: Zuk, G.H. Boszormeny-Nagy, I. (Eds.): *Family Therapy and Disturbed Families*. Palo Alto: Science and Behavior Books, 96-105
- Trautman, E. C. (1961): Psychiatrische Untersuchungen an Überlebenden der nationalsozialistischen Vernichtungslager 15 Jahre nach der Befreiung. In: *Der Nervenarzt* 32, 12, 545-551
- Tyrangiel, S. (1989): Emigrantenkinder - die zweite Generation. In: Herzka, H. S. / Schuhmacher von, A. / Tyrangiel, S. (Hg.): *Die Kinder der Verfolgten*. Göttingen: Vandenhoeck & Ruprecht, 23-80.
- Verein Aktives Museum (Ed.) (1995): *1945: Jetzt wohin. Exil und Rückkehr ... nach Berlin?* Katalog zur Ausstellung vom 1. Mai bis 15. Juli 1995 auf dem Gelände des ehemaligen Anhalter Bahnhofs in Berlin-Kreuzberg. Berlin
- Vollnhals, C. (1991): *Entnazifizierung. Politische Säuberung und Rehabilitierung in den vier Besatzungszonen 1945-1949*. München: dtv
- Völter, B. (1994): "Ich bin diesen Feind noch nicht losgeworden". Verschärfter Identitätsdruck für ostdeutsche junge Erwachsene. In: *ÖZG, Österreichische Zeitschrift für Geschichtswissenschaften*, 5, (4), 547-566

- Völter, B. (1996): Die "Generation ohne Alternative". Generationstheoretische Überlegungen am Beispiel der nach dem Mauerbau geborenen DDR-Jugend. In: Berliner Debatte Initial, 6, 107-118
- Walter, H.-A. (1972): Bedrohung und Verfolgung bis 1933. Deutsche Exilliteratur 1933-1950. Darmstadt / Neuwied: Luchterhand
- Weissmark, M. / Giacomo, D. / Kuphal, I. (1993): Psychosocial Themes in the Lives of Children of Survivors and Nazis. In: Journal of Narrative and Life History, 3, (4), 319-335
- Westerhagen, D. von (1987): Die Kinder der Täter. München: Kösel
- Wetzel, J. (1988): Auswanderung aus Deutschland. In: Benz, W. (Ed.): Die Juden in Deutschland 1933-1945. München: Beck
- Windaus-Walser, K. (1988): Gnade der weiblichen Geburt? Zum Umgang der Frauenforschung mit Nationalsozialismus und Antisemitismus. In: Feministische Studien 1, 102-115
- Windaus-Walser, K. (1990): Frauen im Nationalsozialismus - Eine Herausforderung für feministische Theoriebildung. In: Gravenhorst, L. / Tatschmurat, C. (Ed.), Töchter-Fragen: NS-Frauen-Geschichte. Freiburg i. Br.: Kore, 59-72
- Winnicott, D.W. (1965): The maturational Processes and the Facilitating Environment. London: Hogarth Press and the Institute of Psycho-Analysis
- Winnicott, D.W. (1989). The Concept of Trauma in Relation to the Development of the Individual within the Family (1965). In: Psycho-Analytic Exploration. Edited by C. Winnicott / R Shepherd / M Davis: Harvard University Press. Cambridge, Massachusetts
- Wirsching, M. / Stierlin, H. (1982): Krankheit und Familie. Stuttgart: Klett Cotta
- Wolffsohn, M. (1995): Die Deutschland-Akte. Juden und Deutsche in Ost und West; Tatsachen und Legenden. München: Ed. Ferenczy bei Bruckmann
- Wroblewsky, V. von (1993): Zwischen Thora und Trabant. Juden in der DDR. Berlin: Aufbau Taschenbuch Verlag
- Zilberman, T. / Rosenthal, G. (1994): The effects of the untold stories: The Steinberg / Noifeld Family. In: Rosenthal et. al.(1994): Der Holocaust im Leben von drei Generation. Arbeitsbericht an die DFG. unpublished, 124-150
- Zimmermann, H. et al. (Ed.) (1985): DDR-Handbuch. Köln: Verlag Wissenschaft und Politik
- Zondek, H. (1973): Auf festem FuÙe. Erinnerungen eines jüdischen Kliniklers. Stuttgart:

# Appendix

## Glossary

**Aliyah:** The Hebrew word "Aliyah" means "ascent" and is used to mean the immigration of Jews to Eretz Israel (part of the biblical Land of Israel) or later to the state of Israel.

**Family Sculpture:** A technique whereby the interviewee is given adhesive circles in different colours and asked to group themselves and the members of their family by their emotional closeness or distance (putting them into positions that symbolize their relationships). When the sculpture is finished, we ask them to make a one-sentence statement to each member of their family and then to have each family member say a sentence back to them.

**Genogram:** A schematic diagram of the relationships within the family system based on a family tree of three to six generations.

**Haganah (defence):** The Jewish underground military organization in British Palestine before the Israeli armed forces were established after the founding of Israel.

**Hashomer Hatzair (Young Guards):** A youth movement founded in Vienna in 1916 that combined Marxist, Socialist and Zionist ideology, advocating kibbutz settlements in Eretz Israel. During World War II, its youth leaders fought in the Red Army, in the Resistance and initiated some of the ghetto revolts in the Warsaw and Vilna ghettos.

**Intifada:** Palestinian uprising in the Gaza Strip and the West Bank between 1987 and 1993.

**Lebanon War:** Fought between Israel, Syria, Lebanon and the Palestinians in Lebanon between 1982 and 1985. Israel launched its military invasion in Lebanon with operation "Shalom Hagalil" (Peace of Galilee campaign) in 1982, which aimed at destroying the PLO infrastructure in southern Lebanon.

Nachal: The Hebrew initials of "fighting pioneer youth". An infantry brigade established in 1948 to train young people for the imminent war. In 1949, it became an independent force, combining military service and agricultural training on kibbutzim. Once a framework for cooperative youth groups going to establish new settlements on border territories, it played a major role in security missions and Israeli military operations.

Palmach (brigade): Established in May 1941, this paramilitary organization was initially led by the British and was set up to fight the Germans in the event of an invasion. It was the drafted arm of the "Haganah". Its members did military service in this underground organization, financing their service by working on kibbutzim.

Poland delegation: Since 1984, and stepped up since 1988, many Israeli groups of students have travelled to Poland on tours organized by their schools, towns or youth movements to become familiar with Jewish history in the Diaspora. They explore Jewish life before World War II and go to concentration and death camps in Poland.

Roots papers: An educational project in Israeli high schools, where students are required to write a paper on their family roots. They interview their parents and grandparents about their family history, present their findings and include a chapter about their own biography.

Sabra (cactus): The symbol of a "true" Israeli, born in Israel: prickly on the outside with a sweet, soft interior. By being this way, Israelis believe they can overcome the difficulties of the hard life in Israel and the conflict with the Arabs, while still maintaining their integrity.

The Six Day War June 1967: This short war was preceded by three weeks of full military alert, and Israelis feared they would be destroyed by their enemies. But in the ensuing battles with Syria, Jordan and Egypt, Israeli forces occupied the Golan Heights, the Sinai peninsula and the West Bank. The '67 war was followed by widespread euphoria because Israel had vanquished the military threat and conquered parts of the Biblical land of Israel.

Thematic field: "Defined as the totality of those data, co-present with the theme, which are experienced as materially relevant or pertinent to the theme and form the background or horizon out of which the theme emerge as the centre". (Gurwitsch 1964, p. 4)

War of Independence: Battles between Jewish armed forces and Arabs raged from November 1947 to July 1949. The first Jewish offensive was launched in April and May 1948, capturing most of the territory of the new Jewish state. Israel was declared a sovereign state on 15 May 1948, and a cease-fire was signed between January and July 1949 with Egypt, Lebanon, Jordan and Syria.

Yom Kippur War: In October of 1973, Israel was attacked on the Jewish Day of Atonement by Syria and Egypt. In the early days of the war, Israelis feared the state of Israel would be completely destroyed, as they suffered defeats on both fronts.

## Transcription Symbols

Examples	Description
(says he)	approximate transcription
(            )	incomprehensible; (space between brackets approximately corresponding to length/duration of passage)
((slowly))	transcriber's comments, also descriptions
((coughs))	of moods & non-verbal utterances or sounds
\...((slowly))\	\ marks beginning and end of passage affected
((vividly)) ...	general change of mood, probably continuing
,	brief pause
(5)	pause in full seconds
mo- , more	sudden halt/ faltering / (self-)interruption, utterance discontinued
ye=yes	rapid speech, words closely linked
ye:s	lengthened vowel sound
'yes'	softly, in a low voice
never	syllable (sound) stressed
NO	loudly
NEVER	stress (emphasis) during passage spoken in a loud voice
.....	omissions

## Authors

Sabrina Böhmer, born in 1969 in Berlin, West Germany. Studied sociology and education at the Berlin Technical University. Research assistant in the Sociology Department at the Berlin Humboldt University since 1996. Researcher on this project in 1996. Main areas of work: labour market research, qualitative methods, biographical research.

Michal Dasberg, born in 1967 in Jerusalem, Israel. Studied sociology, anthropology and literary theory. BA from the Department of General Literary Theory at Tel Aviv University. BA thesis: "The third generation and relations between three generations in the families of Holocaust survivors". Worked as a student research assistant on the project from 1995 - 1996. Currently working on her MA and tutoring in the Department of General Literary Theory at the Tel-Aviv University.

Noga Gilad, born in 1963 on a kibbutz in Israel. Studied Behavioral Sciences at the Ben Gurion University of the Negev in Beer Sheva and sociology at the Tel-Aviv University. MA in sociology of education at Tel-Aviv University. 1995 MA thesis: "The memory of the Holocaust in the family: a biographical and narrative research". Researcher on the project from 1993 - 1996. Currently a researcher at the Levinsky college of Education in Tel Aviv.

Petra Jordans, born in 1965 in Mendig, West Germany. Qualified as a pre-primary teacher in 1984, and worked in this field until 1990. Studied social work at Kassel University from 1990 to 1999. In 1996, MA thesis in connection with the research of this project: "On the significance of national Socialism for family histories and life stories". Currently a qualified social worker at the Marburg Early Learning Center for Visually Impaired children.

Christine Müller, born in 1968 in Marktobendorf, West Germany. Studied political science from 1990-1996 at the Berlin Free University. MA Thesis in 1996 on "Left-wing protest movements in life story perspectives". Student research assistant on the project in 1996.

Yael Moore, born in 1962 in Rehovot, Israel. BA in Behavioral Sciences (1985-1989, Beer Sheva University). MA in clinical psychology (1991-1993, Beer Sheva University). MA thesis: "Past and present in the life Stories of second generation Holocaust Survivors". Currently a clinical psychologist at the Beer-Yaakov Mental Health Hospital. Researcher on the project from 1994 to 1996.



Maria Nooke, born in 1958 in Forst, Lausitz, in East Germany. Religious training to work with children and young people from 1979 to 1982 in Radebeul near Dresden. Diploma in religious education. Parish teacher of the Protestant church until 1991 (East Germany). Studied sociology and education at the Berlin Technical University from 1992-1997. Student research assistant on the project from 1993-1996.

Gabriele Rosenthal, born in 1954 in Schwenningen, West Germany. Studied sociology and psychology at the University of Constance. Received her doctorate in sociology from the University of Bielefeld, West Germany, in 1986. In 1993, completed her habilitation thesis on "Experienced and narrated life" at the University of Kassel. Currently lectures at the University of Kassel as Professor for Social Therapy at the Department of Social Work. Headed the research project from 1992-1996. Teaching and research interests cover interpretive sociology, qualitative methods, and biographical research.

Waltraud Schade, born 1956 in Bad Hersfeld (West Germany). Qualified as a pre-primary teacher in 1978, and worked in this field until 1989. Studied social work at the University of Kassel, West Germany, from 1989-1995. In 1995, MA thesis in connection with the research project: "Experiences of persecution in family histories and life stories."

Bettina Völter, born in 1964 in Sindelfingen, West Germany. Studied political science, sociology and history in Erlangen, Paris and Berlin. MA in 1993 in political science at the Berlin Free University. MA thesis on processes of biographical change in young East German adults after the fall of the Wall in 1989. Research on this project from 1993 to 1995. Lecturer at the Institute for Social Sciences, Division of General Sociology, Berlin Technical University since 1995. Currently working on her doctoral thesis on "Process of transmitting the past in East Germany in families of returning emigrants".

## **Academic Journals**

Barbara Budrich publishes a number of high quality academic journals in German and in English. Most journals feature abstracts and substantive contributions in English while the main body is in German. However, the following academic journals are bi-lingual *viz.* in English throughout:

### **Spirale der Zeit – Spiral of Time** Frauengeschichte sichtbar machen – Making Women's History visible

This new journal: The Spiral of Time. Making Women's History Visible shows our world history from a feminist and a universal perspective. In showing the active part of women in history we gain a new view of our historical past and of our present day political possibilities. From the very beginnings of history up to our present day women have taken over the responsibility for the survival of mankind. Realising the historical strength of women enables women and men today to create new visions of a peaceful and democratic future.

Order your free reading copy now!

### **Politics, Culture and Socialization**

Politics, Culture and Socialization is a new quarterly, comprising some 480 pages per year.

The journal publishes new and significant work in all areas of political socialization in order to achieve a better scientific understanding of the origins of political behavior and orientations of individuals and groups.

Order your free reading copy now!

# Social Work

**Sabine Hering & Berteke Waaldijk**

**Guardians of the Poor—Custodians of the Public**

Welfare History in Eastern Europe.

In cooperation with Kurt Schilde and Dagmar Schulte. Preface Walter Lorenz.

**Helfer der Armen – Hüter der Öffentlichkeit**

Eine Wohlfahrtsgeschichte Osteuropas. In Zusammenarbeit mit Kurt Schilde und Dagmar Schulte. Vorwort Walter Lorenz

2006. ISBN 3-938094-58-3

The bi-lingual book describes the results of case studies about the history of social work in Eastern Europe between 1900 and 1960 in eight countries: Bulgaria, Croatia, Hungary, Latvia, Poland, Romania, Russia and Slovenia.

The book reads one half in English, the other identical in German.

**Walter Lorenz: Perspectives on European Social Work**

From the Birth of the Nation State to the Impact of Globalisation

2006. ISBN 978-3-86649-008-6

The book offers explanations and clarifications for the bewildering variety of titles and job profiles in the social professions in Europe. It presents them both as a product of specific national welfare arrangements and as a sign of a special kind of professional autonomy that so far helped to correct national welfare trends.

**Kurt Schilde & Dagmar Schulte (eds.): Need and Care—Glimpses into the Beginnings of Eastern Europe's Professional Welfare**

2005. ISBN 3-938094-49-4

The book gives a collection of case studies by national researchers from the project „History of Social Work in Eastern Europe 1900–1960 (SWEEP)“. This collection is directed at teaching Social Work and History of Social Work in an international context since it focuses on Latvia, Russia, Poland, Hungary, Croatia, Slovenia, Romania and Bulgaria.

# Great Books for Academic Readers

**RENÉ BENDIT & MARINA HAHN-BLEIBTREU (EDS.)**

## **Youth Transitions**

Processes of social inclusion and patterns of vulnerability in a globalised world  
2008. ISBN 978-3-86649-144-1

What will become of today's young people in Australia, Asia, Europe, Latin America and North America? Will they be supportive of the world they live in? Or are they doomed to be criminal drop-outs? The authors investigate to what extent different and contradictory trends of social modernisation and economic progress determine the biographical development and social integration of young people in different countries and world regions.

**ROLAND BRAKE & ULRICH DELLER (EDS.)**

## **Community Development—A European Challenge**

2008. ISBN 978-3-86649-205-9

International experts discuss community development in its historical trends, its present state and its theoretical concepts as well as its practical implementations in eight European countries (Belgium, Bulgaria, Germany, Hungary, Lithuania, Romania, Spain) and the USA.

**YVONNE GALLIGAN & SARA CLAVERO & MARINA CALLONI**

## **Gender Politics and Democracy in post-socialist Europe**

2007. ISBN 978-3-86649-133-5

Utilizing the concept of political representation, the book scrutinizes women's legislative presence and highlights the opportunities and obstacles to parity democracy in this region of Europe.

# Great Books for Academic Readers

**DETLEF GARZ**

## **Lawrence Kohlberg – An Introduction**

2009. ISBN 978-3-86649-285-1

"This is a small but excellently written book. It perfectly serves two purposes at the same time: It gives a readable and comprehensive introduction to Larry Kohlberg's life and work for those who are unfamiliar with this approach, and it sharpens the eyes for those who are in the 'moral development and education business'." — Dr. Wolfgang Althof, Teresa M. Fischer Professor of Citizenship Education, University of Missouri – St. Louis College of Education St. Louis, MO

**GUNDA WERNER INSTITUTE (ED.)**

## **Roadmap to 1325**

Resolution for gender-sensitive peace and security policies

2010. ISBN 978-3-86649-311-7

Globalization and new power configurations in the world have greatly changed the meaning of peace and security. Poverty, climate- and resource-related conflicts, instable governments, regional and international terrorist groups, and criminal organizations all pose a threat to security and stability everywhere. Is there a gender perspective to all this?

**HANS-UWE OTTO**

**HOLGER ZIEGLER (EDS.)**

## **Education, Welfare and the Capabilities Approach**

A European Perspective

2010. ISBN 978-3-86649-290-5

The authors assess the potentials and pitfalls of the Capabilities Approach to issues of education and welfare. Renowned philosophers, sociologists, psychologists, economists and educational scientists explore the conceptual and practical implications of this approach for delivering socially just policies.

# Great Books for Academic Readers

**REINGARD SPANNRING & GÜNTHER OGRIS & WOLFGANG GAISER (EDS.)**

**Youth and Political Participation in Europe**

Results of the Comparative Study EUYOUNG

Preface by Lynne Chisholm

2008. ISBN 978-3-86649-146-5

How do young people in Europe perceive politics? How do they engage in the political realm? Which groups of young people are actively involved? And which learning environments and opportunity structures can foster participation? Furthermore methodological problems of comparative participation research are discussed and the measurement instrument that was developed in this European research project, and is certainly useful for similar studies is presented.

**URSULA VAN BEEK (ED.)**

**Democracy under construction: Patterns from four continents**

2005. ISBN 978-3-938094-23-5

The volume pioneers a new approach to the study of democratisation. It does so by combining comparative and interdisciplinary analyses of South Africa, Poland, (East) Germany, South Korea and Chile, that is, five countries where a similar general thrust of democratisation is set against the most diversified cultural and historical backgrounds.

**JOHANNES VARWICK & KAI OLAF LANG (EDS.)**

**European Neighbourhood Policy**

Challenges for the EU-Policy Towards the New Neighbours

2007. ISBN 978-3-86649-125-0

This book provides the reader with information on what ENP wants, how it works and what the prospects of the Union's cooperation with neighbouring countries are.

# Der Deutsche Bundestag • The German Parliament

Beautiful and instructive—renowned German scholars inform about history, processes and architecture of the German Parliament. Illustrated with many coloured and black-and-white photographs and documents.

Order at  
[www.barbara-budrich.net](http://www.barbara-budrich.net)



Method chronometer

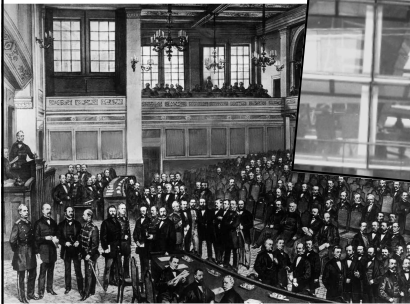

The founding of the Reich (German Confederation), which was created by Emperor of Austria in 1815 for a period of 19 years.

tion, along with the King of Prussia, who was to be the hereditary head of the Confederation, was the Bundestag. Its members were to be directly elected by equal, universal manhood suffrage and secret ballot. The political rights of Parliament, however, remained limited.

The Chancellor, Bismarck, was accountable to the King of Prussia, who presided over the Confederation, but not to Parliament, and this gave the Chancellor great influence over the conduct of policy as long as he enjoyed the confidence of the monarch.

Der Deutsche Bundestag

the Bundestag building was used by five million visitors; a survey indicated that 95% of all adult Germans knew at least something about the Bundestag.

On the day after the removal of the last lengths of material from the Bundestag, Dr. Norman Foster's teams began to clean the building of asbestos and to remove all superfluous items. They had to work quickly, so that

the Federal Convention could convene in the building to elect the President of the Federal Republic on 23 May 1998; moreover, by Christmas 1998 the building would have to be in perfect condition for the formal handover of the keys to the German Bundestag. One of the final tasks was the installation of the Bundestag eagle, designed by Ludwig Gies, which was hung on 15 December 1998.



**Verlag Barbara Budrich • Barbara Budrich Publishers**

Stauffenbergstr. 7, D-51379 Leverkusen Opladen  
Tel +49 (0)2171.344.594 • Fax +49 (0)2171.344.693 • [info@budrich-verlag.de](mailto:info@budrich-verlag.de)  
US-office: Uschi Golden • 28347 Ridgebrook • Farmington Hills, MI 48334 • USA •  
ph +1.248.488.9153 • [info@barbara-budrich.net](mailto:info@barbara-budrich.net) • [www.barbara-budrich.net](http://www.barbara-budrich.net)

[www.barbara-budrich.net](http://www.barbara-budrich.net)

# Books you need to read

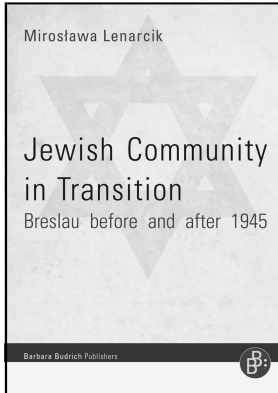

**MIROŚŁAWA LENARCIK**  
**Jewish Community  
in Transition**

Breslau before and after 1945

2010. Ca. 240 pp. Pb. Ca. 24,90 € (D), 25,60 € (A), 44,00 SFr, US\$36.95, GBP 21,95  
ISBN 978-3-86649-262-2

The development and collapse of the Jewish community is described using the example of its welfare and social activities in Breslau/Wrocław. The author focuses on the time from the end of the nineteenth century to the 1940s, when the city was awarded to Poland, in order to show the process of transition of this community.

**URSULA J. VAN BEEK (ED.)**

**Democracy under Scrutiny**

Elites, citizens, cultures

2010. Ca. 300 pp. Pb. 36,00 € (D), 37,10 € (A),  
61,00 SFr, US\$ 52.00, GBP 32,95  
ISBN 978-3-86649-306-3

This book reveals the diverse worlds of history, civic culture and values of South Africa, South Korea, Chile, Poland, Turkey, Germany and Sweden. It explores the similarities and contrasts between the values of the elites and the ordinary people. Written from various disciplinary perspectives and offering both empirical evidence and insiders' knowledge, this book is bound to interest a wide variety of readers.

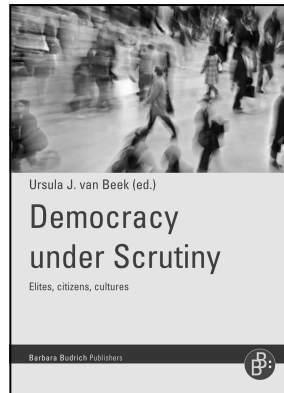

**Verlag Barbara Budrich • Barbara Budrich Publishers**



Stauffenbergstr. 7. D-51379 Leverkusen Opladen

Tel +49 (0)2171.344.594 • Fax +49 (0)2171.344.693 •

info@budrich-verlag.de

US-office: Uschi Golden • 28347 Ridgebrook • Farmington Hills, MI 48334 • USA •

www.barbara-budrich.net

www.barbara-budrich.net